



UI BULLETIN # 26

SUBJECT: Passlock Disablement for Vehicle Remote Start Capability

MODELS AFFECTED: S/T,C/K, M/L & G Trucks

MODEL YEAR(S): 1998 and beyond

DATE: 04/22/99

PAGE: 1 of 9

THIS BULLETIN REPLACES SVIE BULLETIN #2 (ISSUED 11/10/97). This bulletin provides a modified procedure which applies to all 1998 and 1999 model year trucks with the Passlock system. Please note that the procedure provided in the original version of this bulletin can still be used for the models called out in that bulletin.

PURPOSE

This bulletin provides a procedure to disable the Passlock System for vehicles in which remote start/stop switch installations are required. This procedure is required because a remote start system will not function with the current Theft Deterrent System (Passlock) which is included on 1998 model year and beyond S/T, C/K, M/L, and G trucks. Please note that this bulletin is intended to be used only in conjunction with the installation of a remote start/stop system and does not provide a procedure to install a remote start/stop system.

CAUSE

If an attempt is made to start a vehicle by a means other than a key rotation in the ignition switch, the Body Control Module (BCM) will interpret this start as a vehicle theft and disable the fuel injectors.

CORRECTION

A minor wiring modification may be made to allow the vehicle to be started remotely.

This modification includes adding a switch to allow the customer to select "ON" to allow remote starting or "OFF" for normal Passlock operation.

CAUTION: When this modification is performed and the switch is set to the ON position, the theft deterrent feature will be disabled. When the theft deterrent is disabled the SECURITY telltale will light up indicating that the theft deterrent system is NOT functioning.



Upfitter Integration

PASSLOCK MODIFICATION

Refer to appropriate GM service manuals and/or SVMQP Electrical Guideline Manual for instruction on splicing and electrical connections.

1. Select a suitable on-off switch (see note below) which will be used to disable/enable the Passlock System. Mount the switch in a location such that it is accessible to the driver and will not interfere with normal vehicle operation.

NOTE: This is an extremely low current circuit (approx. 7mA), it is therefore very important that a high quality, low energy, fast acting switch be utilized for this application.

2. Turn the ignition switch to the **OFF** position.
3. Locate the steering column harness to instrument panel harness in-line connector. This connector is typically located by the steering column and, depending on vehicle, may be below the instrument panel or behind the steering column shroud. Refer to the illustrations in Figures 1 through 5 (pages 4 through 8) to locate the in-line connector for each model covered in this bulletin.
4. Locate the Yellow Passlock Data Wire (circuit #1836) which is in pin D3 of the female steering column in-line harness connector as shown in Figure 6 (page 8). Cut this wire and splice a 0.5mm² (20 GA) yellow wire to each end of the cut wire. Keep wire length to a minimum. Route modification wires clear of moving parts. Connect the yellow wires to the switch such that the contacts are **OPEN** when the switch is in the **ON** position.
5. Turn modification switch to the **OFF** position (contacts closed).
6. Start vehicle to verify normal operation. If engine "cranks but will not start" recheck the switch position (contacts should be closed), wire connectors and modification wiring.

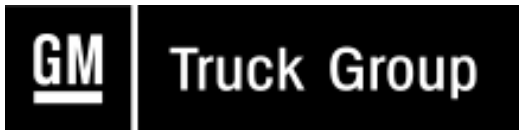

Upfitter Integration

SWITCH OPERATION

To enable remote start:

Start the engine with the ignition key (modification switch must be in the **OFF** position). Turn modification switch to the **ON** position (contacts open). The Security Telltale will light up indicating that the Passlock System is inoperative. Once the security telltale has been on for at least 5 seconds the vehicle can be turned off and then remotely started.

To disable remote start:

The Passlock System can be reactivated by turning the modification switch **OFF** (contacts closed). Vehicle can either be running or off when this is done.

NOTICE

Any condition which removes battery power from the Vehicle Control Module/Powertrain Control Module (VCM/PCM) (e.g. dead battery, disconnected harness connectors, etc.) will prevent the vehicle from being restarted. If the engine exhibits a “cranks but will not start” symptom, check to make sure that the modification switch is in the **OFF** (contacts closed) position.

Please note that the VCM/PCM will record Diagnostic Trouble Codes (DTCs) related to the security system when the modification switch is in the **ON** position (circuit open). This is due to the way that the VCM/PCM interprets this condition.



Figure 1

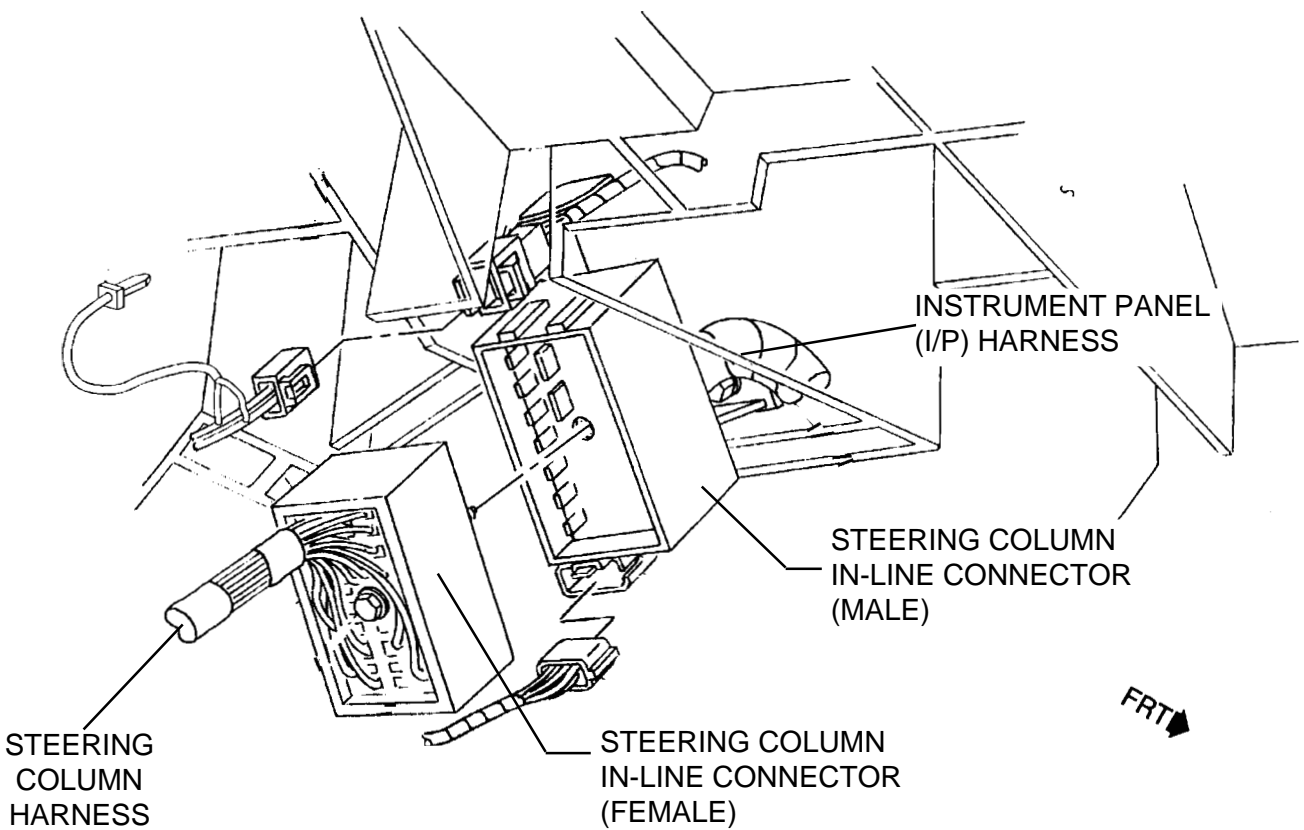

S/T

Upfitter Integration

FIGURE 2

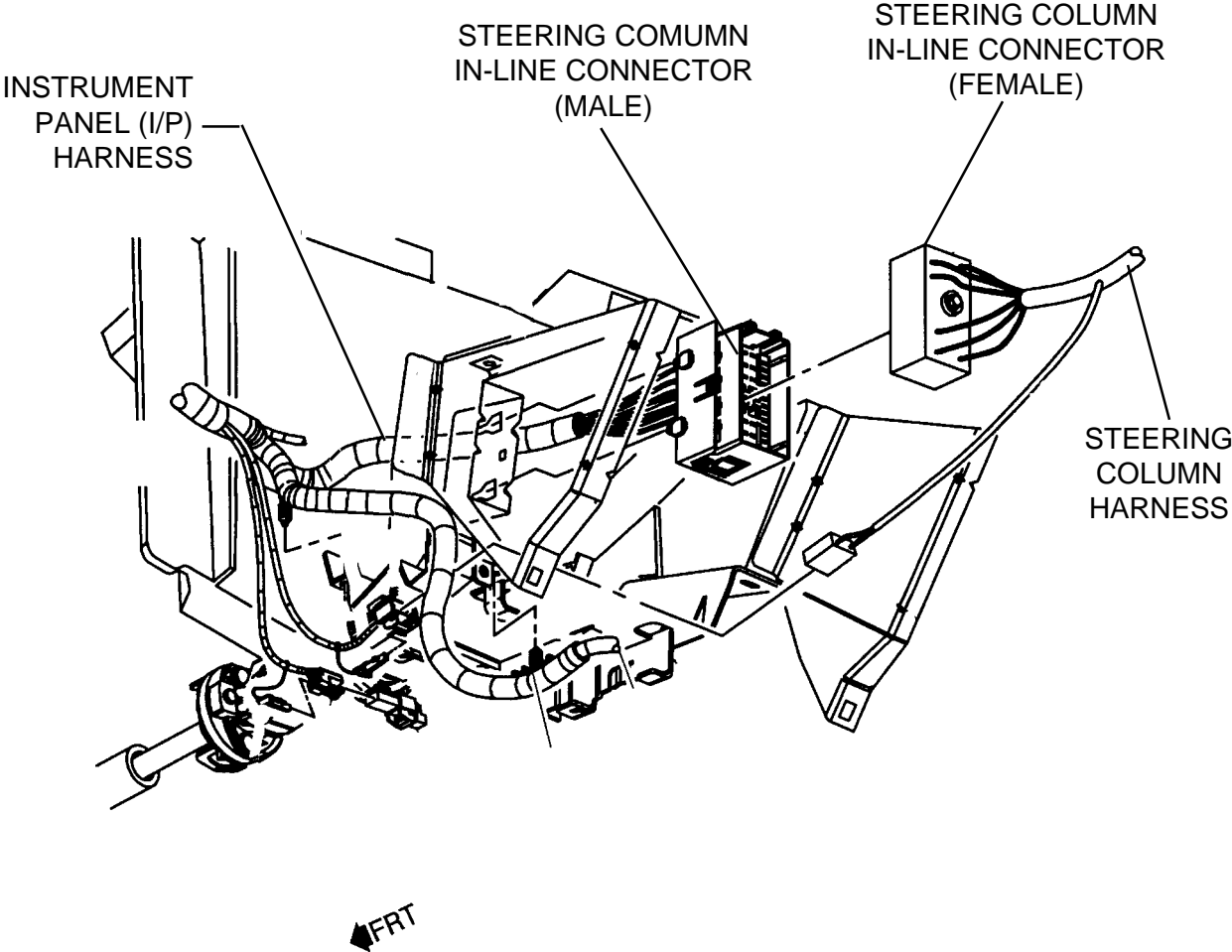

ALL NEW C/K

Upfitter Integration

FIGURE 3

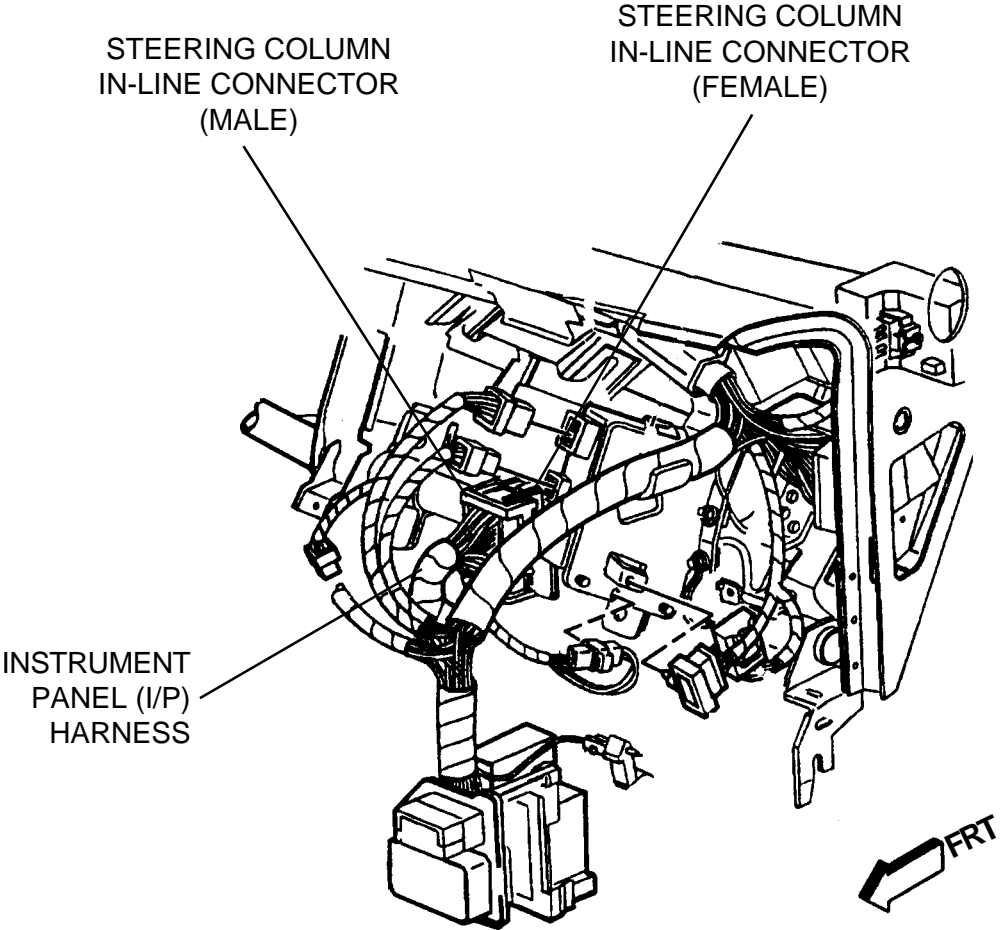

CURRENT C/K

Upfitter Integration

FIGURE 4

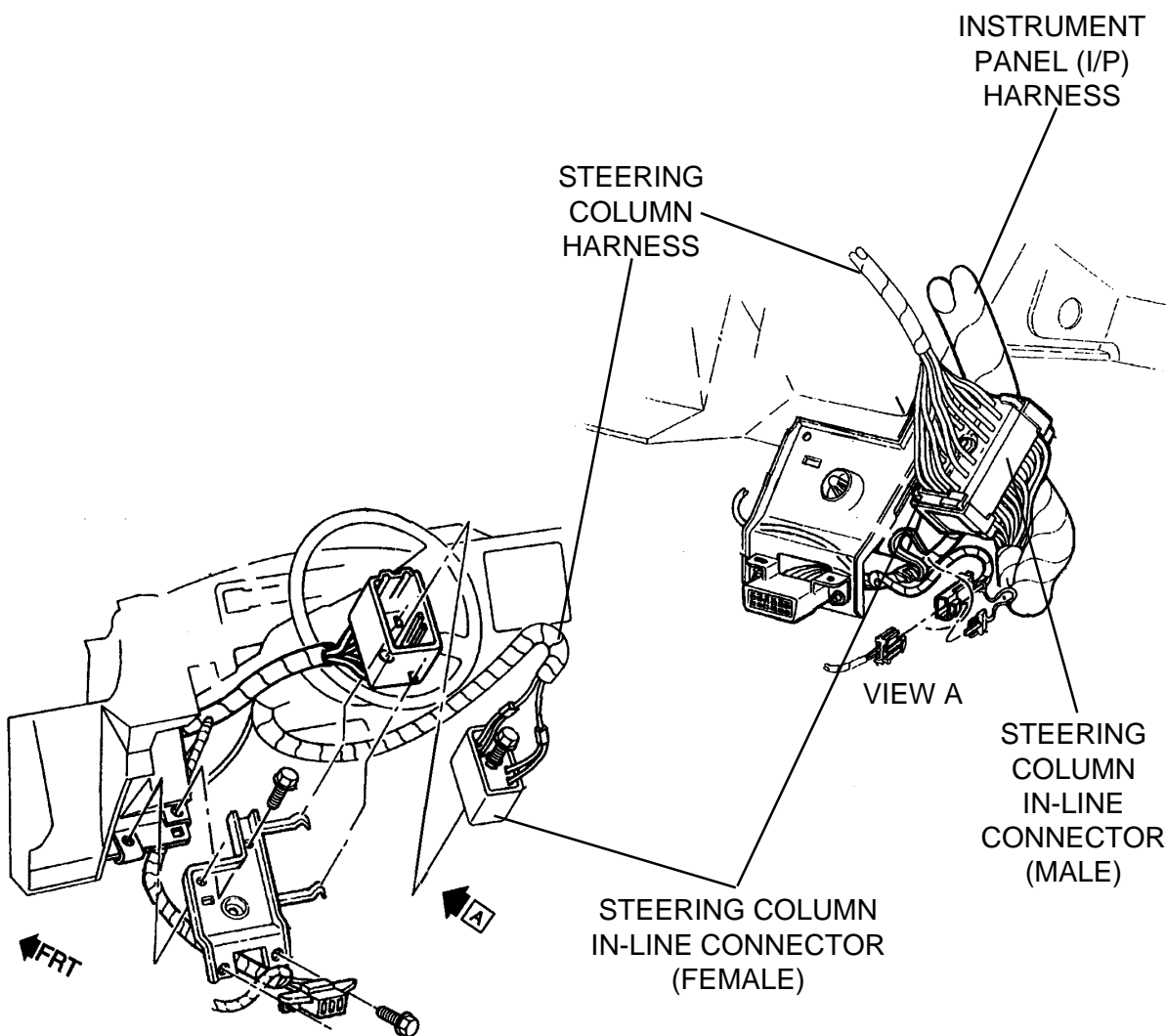

M/L VAN



Upfitter Integration

FIGURE 5

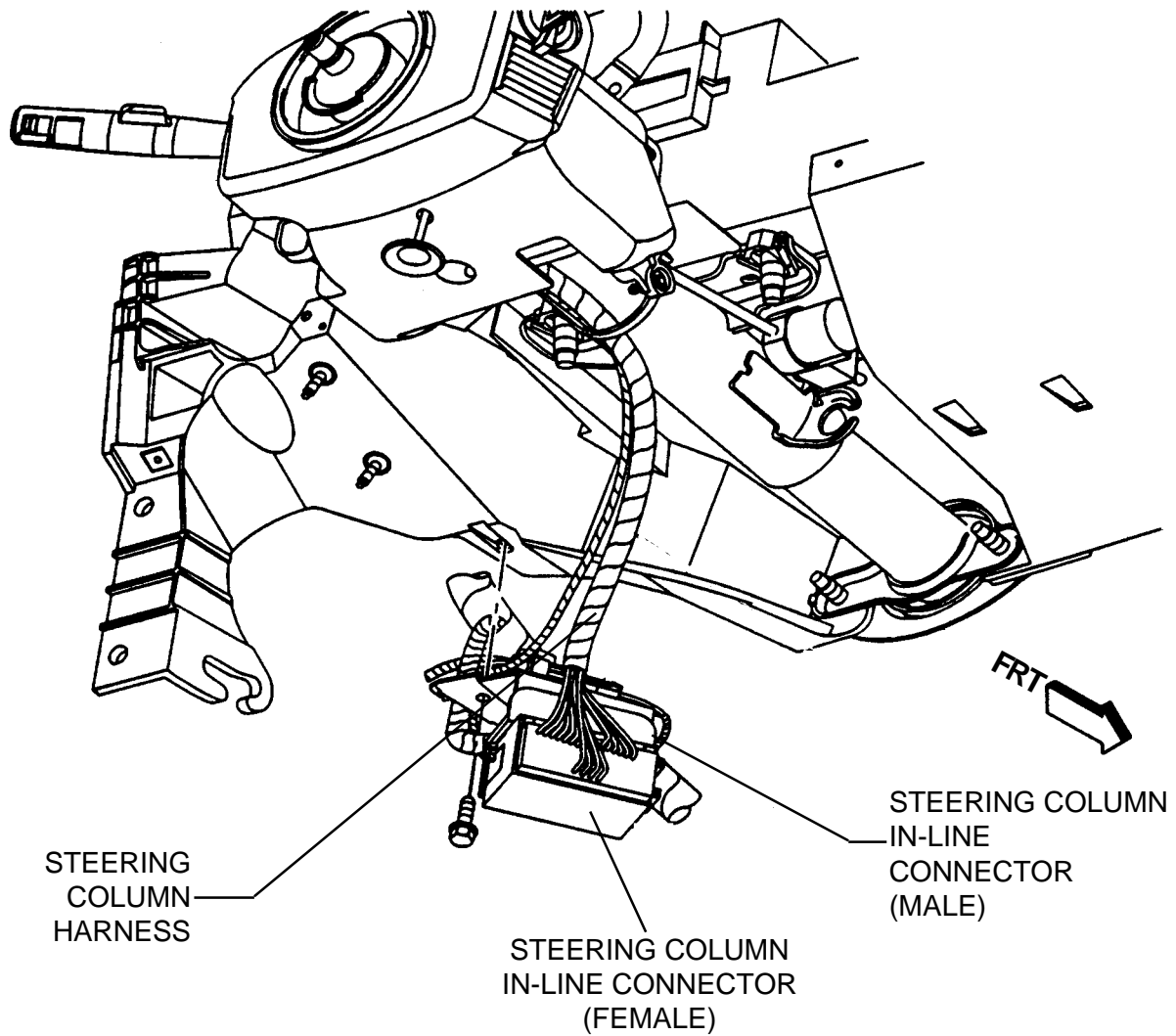

G-VAN

Upfitter Integration

FIGURE 6

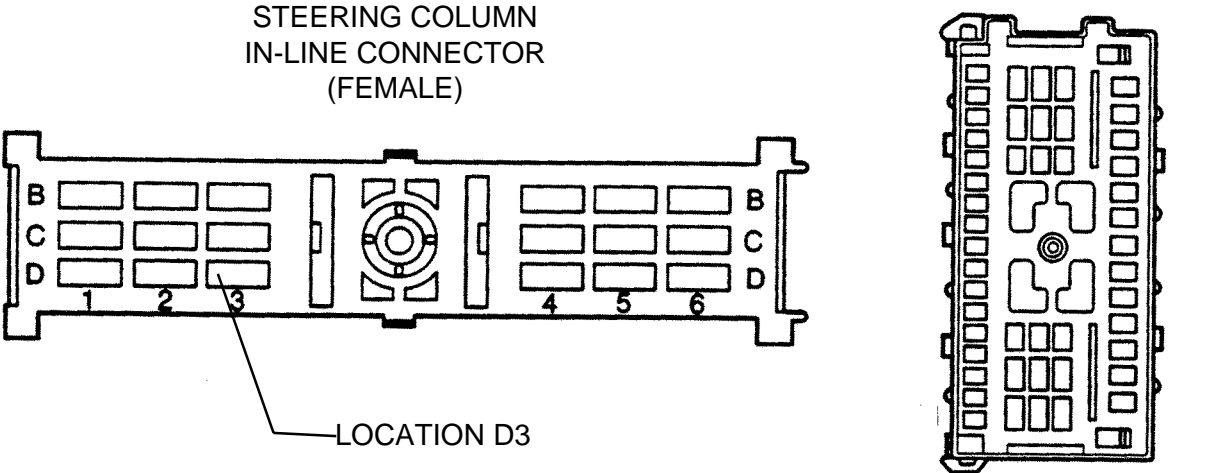

PASSLOCK DATA WIRE
 LOCATION (D3)
 YELLOW (CIRCUIT 1836)

STEERING COLUMN
 IN-LINE CONNECTOR
 (MALE)
 PART #12077822

- | | |
|------------------------|----------------|
| CONNECTOR | PART #12047837 |
| RETAINER | PART #12004737 |
| BOLT | PART #12047743 |
| TERMINAL (LOCATION D3) | PART #12066214 |

STEERING COLUMN IN-LINE CONNECTOR END VIEW