

ATPM

Issue 6.09 / September 2000
Volume 6, Number 9



About This Particular Macintosh: About the [personal](#) computing experience™

Cover Art

"We Do Stand Upon Giants"

Copyright © 2000 by [Catherine von Dennefeld](mailto:Catherine.von.Dennefeld@eternalrings.com)¹

<http://www.eternalrings.com>

We need new cover art each month. [Write to us!](mailto:write@atpm.com)²

Editorial Staff

Publisher/Editor-in-Chief	Michael Tsai
Managing Editor	Daniel Chvatik
Associate Editor/Reviews	Paul Fatula
Copy Editors	Raena Armitage Johann Campbell Ellyn Ritterskamp Brooke Smith Adam Zaner <i>Vacant</i>
Publicity Managers	Christopher Turner <i>Vacant</i>
Webmaster	Michael Tsai
Assistant Webmaster	A. Lee Bennett
List Server Host	Evan Trent
Beta Testers	The Staff

Contributing Editors

Games	<i>Vacant</i>
Graphics	Grant Osborne
How To's & Reviews	Christopher Turner
Interviews	<i>Vacant</i>
Music	David Ozab
Networking	Matthew Glidden
Opinion	Tom Iovino Mike Shields <i>Vacant</i>
Reviews	Eric Blair Jamie McCormack Gregory Tetrault Evan Trent <i>Vacant</i>
Shareware	<i>Vacant</i>
Technical	Evan Trent
Trivia	Edward Goss
Web	David Spencer

Artwork & Design

Graphics Director	Grant Osborne
Graphic Design Consultant	Jamal Ghandour
Layout and Design	Michael Tsai
Cartoonist	Michael Morgan
Blue Apple Icon Designs	Mark Robinson
Other Art	RD Novo

Editors Emeritus

RD Novo
Robert Madill
Belinda Wagner

Contributors

Eric Blair
Daniel Chvatik
Paul Fatula
Matthew Glidden
Edward Goss
Jens Grabenstein
Tom Iovino
Michael Morgan
Mark Montgomery
Grant Osborne
David Ozab
Mike Shields
Brooke Smith
David Spencer
Gregory Tetrault
Macintosh users like you

Subscriptions

Sign up for [free](http://www.atpm.com/subscribe/) subscriptions using the [Web form](http://www.atpm.com/subscribe/)³ or [by e-mail](mailto:subscriptions@atpm.com)⁴.

Where to Find ATPM

Online and downloadable issues are available at <http://www.atpm.com>.

ATPM is a product of ATPM, Inc.
© 1995–2000, All Rights Reserved
ISSN: 1093-2909

The Tools

Acrobat
AppleScript
BBEdit
Cameraid
FileMaker Pro
FrameMaker+SGML
Frontier
iCab
ImageReady
Interarchy
LetterRip Pro
MacPerl
Mesh
Mailsmith
Photoshop

1. mailto:artiste@napanet.net
2. cover-art@atpm.com

3. <http://www.atpm.com/subscribe/>
4. subscriptions@atpm.com

Snapz Pro
ShrinkWrap
StuffIt

The Fonts

Cheltenham
Frutiger
Isla Bella
Marydale
Minion

Reprints

Articles and original art cannot be reproduced without the express permission of AT^{PM}, unless otherwise noted. You may, however, print copies of AT^{PM} provided that it is not modified in any way. Authors may be contacted through AT^{PM}'s editorial staff, or at their e-mail addresses, when provided.

Legal Stuff

About This Particular Macintosh may be uploaded to any online area or BBS, so long as the file remains intact and unaltered, but all other rights are reserved. All information contained in this issue is correct to the best of our knowledge. The opinions expressed in AT^{PM} are not necessarily those of this particular Macintosh. Product and company names and logos may be registered trademarks of their respective companies. Thank you for reading this far, and we hope that the rest of the magazine is more interesting than this.

Thanks for reading AT^{PM}.



Sponsors

About This Particular Macintosh is free, and we intend to keep it that way. Our editors and staff are volunteers with “real” jobs who believe in the Macintosh way of computing. We don’t make a profit, nor do we plan to. As such, we rely on advertisers to help us pay for our Web site and other expenses.

We would like to thank our exclusive sponsor, Small Dog Electronics, for its generous support of AT^{PM}, the Macintosh, and all things cool. Sponsorship does not imply endorsement, and endorsement does not imply sponsorship. Thank you for your support.



<http://www.smalldog.com>

You can help support AT^{PM} by buying from online retailers using the following links: [Amazon.com](http://www.amazon.com)¹, [MacConnection](http://www.macconnection.com)², [MacMall](http://www.macmall.com)³, [MacZone](http://www.maczone.com)⁴, and [Outpost.com](http://www.outpost.com)⁵.



-
1. <http://www.amazon.com/exec/obidos/redirect-home/aboutthisparticu>
 2. <http://service.bfast.com/bfast/click/mid9452939?siteid=13311227&bfpage=machomepage>
 3. <http://www.commission-junction.com/track/track.dll?AID=53427&PID=297078&URL=http%3A%2F%2Fwww%2Emacmall%2Ecom%2Fmacaffiliate>
 4. http://service.bfast.com/bfast/click?bfmid=1942029&siteid=26240435&bfpage=mac_zone
 5. <http://www.linksynergy.com/fs-bin/stat?id=N00D3BtDeo0&offerid=2161&type=3>

Welcome

Welcome to the September 2000 issue of *ATPM* (About This Particular Macintosh). This issue contains:

Columns

Apple Cider: Too Much Information

Tom Iovino presents his thoughts on today's information overload and how it affects our lives and relationships. Do we really need all that technology?

"Today, the world moves a whole lot faster than it used to. The speed limit on the information superhighway is fast approaching the speed of thought."

Beyond the Barline: My Summer at Camp—Part One

David Ozab reports his experiences with the Metasynt summer camp, and he explains the basic functionality and the special characteristics of the program.

"I've come to realize lately that there are two kinds of music software: closed systems—like sequencers, hard disk recorders, software synths, or samplers—are designed to perform a specific task; open systems—examples include Metasynt, Kyma, and Max—provide a paradigm, but do not prescribe the results."

Hollywood: I Couldn't See It

Mike Shields gives us his take on recent events in digital video, among others the MPAA lawsuit about DVD playback software.

"If I buy a DVD, I should be able to play it on the machine of my choosing, whether that be a DVD player or a computer with a DVD drive. The software that allows me to do this should be transparent."

About This Particular Web Site

David Spencer introduces MacLotto (lottery of Macintosh products), DealMac (deal finder), OpenTable & Foodline (restaurant reservations), EarthCam (Webcams around the world), and VersionTracker (tracks new versions of software).

Segments: Why My Next Mac Will Be A Cube

Matthew Glidden shows his philosophical reasons for wanting the new G4 Cube. It's not just design, although that's part of it.

"Computer design is like Dr. Dolittle's pushme-pullyou beast, simultaneously seeking the opposing goals of contextual simplicity and computational power."

Graphics and the Internet: The Animated GIF

In this short tutorial, Grant Osborne teaches us how to create animated GIFs, when to use them, and when to avoid them.

"Your eyes are naturally drawn to anything that moves. Imagine settling down to read your favorite daily newspaper and finding at the bottom of the page a little guy jumping up and down, trying to put an envelope in a dancing mailbox."

Reviews

DoorStop Personal Firewall 2.0—Paul Fatula

Firewalls used to be primarily for corporations. Times have changed, and always-on Internet connections require improved security for Macs at home. Can DoorStop Personal Firewall 2.0 deliver that security?

"With more personal computers being left online 24 hours a day, the desire, if not need, for a firewall of some sort is on the rise. Like NetBarrier, DoorStop offers Macintosh users protection from the network. However, the similarity ends there. With a very different user interface, and a feature set that sticks to the basics, DoorStop will likely appeal to novice Mac users."

Gerry's ICQ d44.1—Daniel Chvatik

You thought "You've Got Mail" was in? Think again. Gerry's ICQ takes Mac instant messaging and chatting to new heights. Is it time to join the crowd?

"ICQ has developed beyond simple talk, and Gerry's ICQ reflects that. In addition to messaging and chatting, it lets you send files or URLs."

icWord 1.0—Brooke Smith

Microsoft's Word has become the *de-facto* standard format in word processing. But what if you don't own the program? icWord to the rescue!

"icWord seems to be a practical and user-friendly program for those Mac users who don't have Word and need to read Word documents. The simple toolbar layout is easy to navigate without the help of the documentation. The Tile and Stack Windows options are very useful, and the overall look of the program [...] is clean and tasteful."

Kyma 5.0—David Ozab

David Ozab takes you into the world of Kyma, a software interface for the Capybara 320 sound processor.

"You get what you pay for, and, for the price, Kyma 5.0 is an unbelievable bargain. For the same cost as a typical keyboard workstation you get a true black box—synthesis, sampling,

MIDI, audio processing, algorithmic composition, and real-time interaction; it's all there."

Nomad II 32 MB—Eric Blair

The third-generation MP3 player Nomad II may just have what it takes to draw you into the world of MP3 music. Or maybe not?

"It's long been said that a technology is not truly useful until its third generation sees the light of day. If that adage is to be believed, now is the time to jump on the portable MP3 player bandwagon."

PGPfreeware 6.5.2 and SafeMail 2.1—Gregory Tetrault

Want to protect your e-mail communication but don't know how? Gregory Tetrault takes two encryption programs for the Mac under a probing light. See for yourself what he uncovered.

"I highly recommend PGPfreeware. It handles all your e-mail signature and encryption needs and costs nothing but download time. Its manuals and help files are excellent."

StoryBox Picture Frame (Preview)—Daniel Chvatik

Daniel Chvatik previews the promising new picture frame from Weave Innovations and the accompanying StoryBox picture exchange and content delivery system.

"Computers used to be simply tools for work, and many people were happy to enter a computer-free environment after the work was done. Staring at a flickering screen for several hours a day is quite enough for them. But as speed, bandwidth, and memory capacity keep increasing, computers and the associated technologies are no longer restricted to the workplace."

Extras

Cartoon: "In Your Dreams"

Michael Morgan on the sexyness of speed.

"I don't obey no speed limits where processors are concerned."

Desktop Pictures: Mark Montgomery

ATPM reader Mark Montgomery has submitted some stunning photographs with various motives.

Desktop Pictures: Konstanz Part II

Jens Grabenstein concludes the second part of his picture series from Southern Germany.

Trivia: Crack the Code

Edward Goss dares you to crack the code names of Apple's PowerBooks. Do you have what it takes?



ATPM's New Print-Optimized PDF

You mean people actually print it? I thought on-screen magazines were meant for reading on screen, hence the name. :-)

I like the format you already have. Thanks for a great magazine!

—*Christopher Laslett, United Kingdom*

Well, I personally never print it, but many people have requested a print version, and from the feedback it has received it seems to be quite popular. It also works well for people with very large displays (such as 21").

We are not going to remove the other format because of the print version, but we are contemplating making a more special "screen" version with a landscape layout to fill the screen. Would you prefer that over the current on-screen PDF?

—*Daniel Chvatik*

Praise for the Print-Optimized PDF

Much better—I can print this out and take it on my train journeys without having to carry around a dead tree with me.

Well done for thinking about and doing this!

—*Stewart Armstrong, United Kingdom*

PDFs Display in My Web Browser

How do I download ATPM to my hard disk? When I click on the PDF screen-optimized link, it opens in Adobe Acrobat format in Internet Explorer. I cannot save this. Instead I'm forced to stay online to read it. What am I doing wrong?

—*Melanie, British Columbia, Canada*

The reason it displays in your browser is because you have the PDF Reader browser plug-in installed in your browser's plug-in folder. There are three ways around that:

After the PDF has loaded inside your browser, click the Save button in the Acrobat button bar to save the PDF to disk.

You can uninstall the plug-in by removing it from the folder and restarting the browser.

Or you can *option-click* the link to the PDF you want to download. This will bypass the plug-in and download the PDF straight to your hard disk. —*Daniel Chvatik*

File Sizes

On my iBook one batch of .k files are shown as taking up between 8 and 20K each, but when I have the iBook and the blue G3 ether-networked, and view the iBook files on the G3's screen, those 12–20K files are shown as taking up 97K each.

When I Get Info on the folder that contains them, I see the actual size as 900K in both screens: but while the iBook tells me they take 1.6 MB of space, the G3 tells me they take up 14 MB.

Don't measurements of disk space normally work across a Mac-only network?

On the iBook the .k files are on a hard disk which is 3 GB, and the .k files are (still) 8–20K. The folder containing them is shown as taking up 1.6 MB. On the G3, I have copies of the same files on a partition which is 750 MB, and they're shown as taking up 25–28K each, while the folder is shown as taking up 4 MB space.

Huh? The bigger the partition/disk size, the bigger the minimum space per file should be.

—*David Kettlewell, Estonia*

What you have discovered is actually a known bug in Apple's implementation of File Sharing and also in AppleShare IP, Apple's professional strength file sharing server suite.

The issue emerged as a result of Apple's move to HFS+. As you may know, File Sharing (and ASIP) allow a Mac running an older OS (prior to OS 8.1) to log onto Macs that are sharing HFS+ volumes. However in facilitating this there are often discrepancies in file sizes and byte counts as you have noticed.

I have not been able to duplicate this problem myself but many users have reported it on the AppleShare IP Discussion List [hosted¹](#) by Apple. You can [search²](#) the archives.

I believe Apple is working on a fix for the problem but the AppleShare/File Sharing team is not exactly the fastest. Keep in mind that the sizes your iBook reports for its own data are accurate. The figures the G3 gives you when you log on to the iBook are incorrect and the result of fancy "behind the scenes" networking technology that is allowing two different file systems to talk to each other magically.

I am not aware of any workarounds for this problem aside from reformatting your iBook hard drive as HFS standard. Alternatively you could partition your drive and make one partition HFS+ and the other HFS Standard. Then share only the Standard partition. Or you could do this to your G3 and share the G3 instead of the iBook. —*Evan Trent*



1. <http://lists.apple.com>
2. <http://lists.apple.com/search.html>

Apple Cider: Random Squeezings From a Mac User

by Tom Iovino, tiovino@atpm.com

Too Much Information

I really do love my grandmother.

Here's an 80-year-old Italian woman who is very active and robust. She's always sending newspaper clippings from the [Bergen Record](#)¹ to me, of articles written about her senior exercise class or, yes, another meeting with the Mayor noting yet another meeting when she was recognized for her community leadership. She lives independently and keeps her home as tidy as can be. And just give her a chance to whip up one of her signature massive Italian meals, and, let me tell you, you may never look at food the same way again.

The reason I treasure her the most is that she possesses a wealth of family information in her memory. If you ever had a chance to sit down and join her for a cup of coffee, you would be amazed by the stories from her youth. Living through the Great Depression. Her memories of World War II. Meeting my grandfather and watching his dairy business grow. Family triumphs and family tragedies help weave the tapestry of her life.

The one thing she remembers most vividly is living in a world where the family radio, newspapers, and talking with your neighbors were the primary sources of information. People interacted with each other more back then, because they had to. Neighborhoods grew tightly knit through the personal bonds people made with each other.

Fast forward to 2000.

Hold on to your hat, Toto, we're not in Kansas anymore.

Today, the world moves a whole lot faster than it used to. The speed limit on the information superhighway is fast approaching the speed of thought. Billions of dollars of commerce are conducted from the comfort of a customer's home. Data is becoming the world's currency.

This increase in the speed of the world has been primarily due to the development and application of advanced technology. While this has made our world a much more exciting place to live, has it necessarily made things better?

Technology, for all of its wonders, tends to make us more isolated than we have ever been before. We drive as quickly as we can from point A to point B with our windows rolled up, stereo on, and an ear glued to the cell phone. People can live for years at a house or apartment merrily watching the 12,965,278 channels their satellite dish provides, or chatting with a goat herder from Somalia on the Internet until they get

carpal tunnel syndrome, and never really get to know their neighbors.

Sure, some neighbors are jerks and those other drivers out there may have gotten their licenses out of a box of Corn Flakes, but they are still people. These interpersonal skills are like any muscle in our bodies—the more we use it, the stronger it becomes. With a lack of interaction, we lose our ability to work out problems with people, and the desire to be courteous nearly vanishes. G. Gordon Liddy once said that courtesy is the lubricant of society. It keeps us working together smoothly and prevents a great number of clashes.

Recently, I have stopped and taken notice as to how pervasive technology is. It surrounds us, influences our actions, and turns up in places we don't really care to see it. Some places where this is the case include:

- Here in the Tampa Bay area, the roads are not exactly the safest places to be. Thoroughfares which were designed for a small permanent population and a seasonal influx of tourists now have to handle a permanent population of more than two million. Since just about everyone here in Florida is originally from somewhere else, there are also a great number of driving philosophies sitting behind the wheel. Being on the roads is a dangerous activity, but I can't tell you how many other drivers I have seen who are conducting lengthy, animated conversations on their cell phones. At 55 miles per hour, a driver travels 80 feet every second he or she is distracted by answering a call, discussing business, or searching for the call end button. It may not sound like much now, but it may become very important if you are stopped at a traffic light waiting to see if the driver behind you has noticed that you are no longer moving.
- Companies are in the business of making money, plain and simple. Most companies help themselves achieve this goal by assembling lists of customers who subscribe to magazines, purchase products, or use Internet services from their competitors. While this use of technology does pose a danger should a deceptive business lay their hands on a client list, most of the problem with this practice is that it's just plain annoying. With your information available to whomever wants it, your name, address and phone number are bought and sold as a commodity, which increases the volume of junk mail, sales calls, and spam in your e-mail in box. And—raise your hands if this applies

1. <http://www.bergen.com/>

to you—who hates those automated sales calls that make you rush out of the shower or get up from the dinner table? Note to salespeople, if you want to hold on to the remote possibility that I will purchase your service or product, please don't have computers call me to deliver a sales pitch. Thanks.

- While these are some expected concerns, the wackiest story about technology running amok involves a report I saw on the [BBC's Internet Site](#)¹. Apparently, Levi Strauss, the company most closely associated with blue jeans; and Phillips, one of the largest electronics companies in the world, are joining forces to yes—you guessed it—release a clothing line with advanced electronics integrated into the fabric. According to the report:

The clothes, which could become the essential fashion of the future, enable the wearer to be fully connected to the World Wide Web at all times. Jackets equipped with a mobile phone, a portable audio device, a remote control panel, a microphone and headphones, will cost about £600.

I thought that the whole idea of getting dressed up in expensive clothes was to go out to get away from the computer and meet some real, genuine flesh-and-blood folks. Now, people who really need to work on their interpersonal skills can go out without the danger of actually speaking to and interacting with people.

1. http://news.bbc.co.uk/1/hi/english/sci/tech/newsid_882000/882254.stm



Isn't that just great?

Would I trade today's world, with its modern conveniences, health improvements and higher standard of living?

Heck no.

Politicians love to wax poetic about the simpler life of bygone days. What they never mention is that people died of diseases that we never hear about today, conducted business at a snail's pace, and had access to only a limited amount of information. Workers were not protected from dangerous working conditions or poisonous chemicals. Simple things such as giving birth to babies had enormous, dire risks.

You can keep all of that nostalgia, thank you.

I suggest that everyone who has to work with a computer all day and everyone who sees computers as a hobby takes up a different type of diversion—something which has no connection to technology. In other words, ditch the pager, chuck the cell phone, and make yourself scarce for a while. My brother likes to go camping. I have taken up wood-working. I also take my son to the park.

I also suggest that perhaps you meet some of the folks you call your neighbors and strike up a conversation. Hone your people skills. Practice courtesy. You never know when these ageless skills may come in handy.

Yeah, my grandmother has seen a lot. From the biplanes and zeppelins of years past to the International Space Station, things have certainly changed over her 80 years. But I have yet to find a substitute on the Internet for the many lessons she has taught me about life.

My Summer at Camp—Part One

Question: What is Metasynth?

- An open-ended synthesis and sample processing platform with a unique visual interface.
- Air control.
- One very cool app!
- A mega phat software synth.
- A multidimensional, deep sound exploration and composition tool.
- A wondrous tool allowing an individual to tap into the limitless reaches of sound.
- A super diggidy dope software, synth allows users to define a seemingly endless number of parameters and *create!*
- A system which converts graphics into sounds.
- A mega sampler, player, sample editor, paint program, FM synthesizer, and an integrated thousand pixel and sound oscillation monster!
- The most creative music program I've ever seen.
- A powerful tool for creating, manipulating, translating, and simulating sound design and synthesis.
- A sound design tool, sampler, and instrument design tool with incredible power and flexibility to fit any music creation technique or style.
- A paradigm shift into infinite possibilities. A metaphor that encourages exploration, growth, and deep listening. Serendipitous composition.
- Metasynth is like vodka: it completely takes on the taste of whatever you put with it and totally enhances the taste!

Those are the opinions of a random cross-sample of users (I wrote the first one, by the way) that gives you some idea of both what Metasynth does and the enthusiasm it generates among both novices and experts.

And Now for Some Background

[U & I Software](http://uisoftware.com)¹ is a company founded by French-born programmer, visual artist, and musician, Eric Wenger, out of a desire to build a sound design application that could take advantage of the latest Macintosh technology. Why, he asked himself, did Soundesigner II, Digidesign's venerable stereo digital editing application, still record destructively to disk?

1. <http://uisoftware.com>

Why did it still represent sound in monochrome? (Updates had limited colors.) Why did it offer so few DSP options? Wenger realized he could write a more flexible and up-to-date application himself, while incorporating his background in visual design software, such as Bryce which he co-designed with Kai Krause, the co-founder of MetaTools (now MetaCreations). The result was Metasynth.

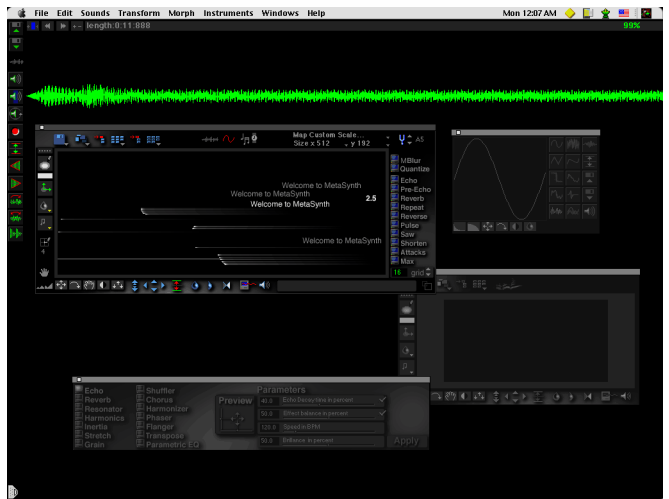

What's Special About Metasynth?

Well, as I said in my description, Metasynth is “an open-ended synthesis and sample processing platform with a unique visual interface.” The most important adjective for me in that statement is “open-ended.” I've come to realize lately that there are two kinds of music software (and I'm sure this goes for visual design software too). Closed systems—like sequencers, hard disk recorders, software synths, or samplers—are designed to perform a specific task. The best among these combine elegance and versatility, but they are ultimately restricted by the function they serve. Open systems—examples include Metasynth, Kyma, and Max—provide a paradigm, but do not prescribe the results. It is possible, and actually quite likely, that you will realize something in these programs that the software designers never envisioned. A MIDI sequence, however interesting, is still a MIDI sequence.

It is also no surprise that these open-ended applications are all made by smaller companies. Yes, Max was acquired by Opcode in 1990, but David Zicarelli took the application

with him to Cycling '74 (and regained all the rights from Gibson recently), and now answers his own tech support e-mail. Carla Scalletti, the founder of Symbolic Sound, will personally talk you through Kyma crises on the phone, and Eric Wenger, along with Edward Speigel (who joined U & I recently) who run the company booth at Macworld SF themselves, post responses regularly to the U & I mailing list, and take time out of their schedules for events like the Metasynth Camp. The combination of flexible, open-ended software, and personal attention has built each of these companies a fiercely loyal following.

How the Camp Came to Be

Andy Lefler, a glass blower turned digital artist, was brought to the U & I mailing list through his passion for Artmatic, a wonderful and inexpensive fractal art and animation program also created by Eric Wenger. Lefler became increasingly interested in Metasynth through discussions on the list, and was the one who originally floated the idea of bringing a group together to learn more about the program. Several ideas were proposed, various locations, even an online gathering, but in the end Todd Barton (of Southern Oregon University, and also the Music Director of the Oregon Shakespeare Festival) secured the [Media Center](#)¹ in the SOU Department of Music, and Metasynth Camp was born. I wasn't on the U & I mailing list at the time, but Todd contacted me (he has a long standing relationship with Future Music Oregon) and, given that Ashland is only a three-hour drive from Eugene, I jumped at the opportunity.

Getting to Know You

We all met at the Media Center at 8 PM Thursday. Todd had everyone introduce themselves, and I quickly realized that I was one of the “youngsters” of the group. The most common statement was, “Well I started in the '70s with a Moog (or Buchla, or Surge, or some other analog synth).” Yes, some of my early experiences were with modular analog synths, but they were practically museum pieces by this point, and I was learning MIDI sequencing at the same time.

Then Todd showed us the lab, and we each claimed a workstation with a 266 MHz [G3 all-in-one](#)² (a rare predecessor to the iMac that was only sold to schools) and some MIDI gear that was inconsequential in terms of our work with Metasynth. The presentation setup in front of the room consisted of a 450MHz G4 running a video feed to a projector.

Todd also showed us the camera setup that would be used to videotape the entire weekend: three cameras, plus a FireWire feed from the G4 for capturing video and audio signals mixed together from the G4 and a live microphone. Little did we know it then, but the camera crew, led by Greg and Mariko Moore, would have their hands full all weekend.

1. <http://www.sou.edu/music/media.htm>

2. <http://www.apple-history.com/quickgallery.html?where=g3aio.html>

The G4 would crash Friday afternoon and be replaced by Greg's Blue and White G3 350, and they would then have to improvise connections until the G4 was working again.

We wrapped up early (about 9:15, the only day we would) and I headed back to the SOU dorms, which were pretty good accommodations for the price (\$24.50 a night). There I downloaded my e-mail on my Visor (putting the [modem I reviewed](#)³ to good use), wrote a quick note to my girlfriend (she was in Indiana for her high school reunion), and raided the snack machines downstairs. Tomorrow morning would come bright and early, but with the heat I didn't get much sleep.

Friday Morning—The Basics

We began Friday morning where most begin in Metasynth, the image synth. Todd gave a demonstration and we all built a few simple examples. The one I'll cover here illustrates a simple way to build drum patterns. The image synth includes a “grid” setting which, combined with a repeating “brush mode,” lets you easily draw pulses which you can build into more complex rhythmic patterns. The first example shows a basic pattern. Time is mapped horizontally, and pitch is mapped vertically. Red is left, green is right, and yellow is in between. Blue in this case marks the basic pulse (the “Blue Channel” has many uses, but it never produces sound on its own).

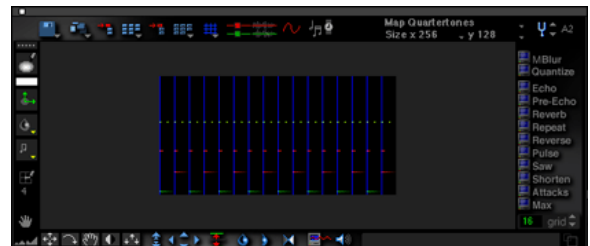

[Rhythm 1](#)⁴

a. <http://www.atpm.com/6.09/mp3/rhythm1.mp3>

Note the sine wave icon in the Image Synth window. As you can hear, if you download the linked MP3 file, the pattern is mapped to a simple sine wave oscillator (set in the Wave Table window). In the next example, I have done two things—first I added a syncopated pattern above the original top line, then I remapped the pattern to a drum kit. Unlike Todd's example,

3. <http://www.atpm.com/6.05/handspringmodem.shtml>

where the top two lines are mapped to a high-hat, my version mapped the same pattern to a bass drum.

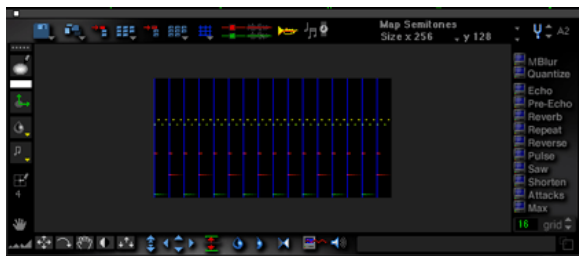

Rhythm 2^a

a. <http://www.atpm.com/6.09/mp3/rhythm2.mp3>

I liked the driving “techno” feel of the fast bass pulse, but was missing a high-hat, so I added one; and, using a filter from the preset file, shifted it into a three-against-two pattern. I added a stereo filter (from the same set of presets) to both the high-hat and bass drum to get the following result.

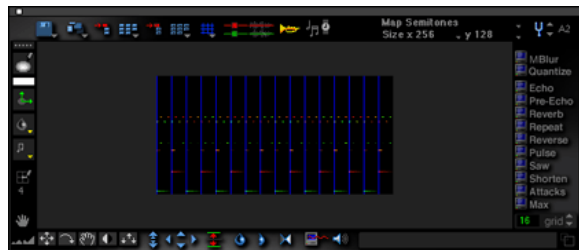

Rhythm 3^a

a. <http://www.atpm.com/6.09/mp3/rhythm3.mp3>

We then moved to the Filter window, which analyzes sound files generated from the Image Synth (or any other source) and applies graphic filters to them. Todd showed us a number of different filter patterns. The example I give here is a gradual filter sweep up through the total frequency range.

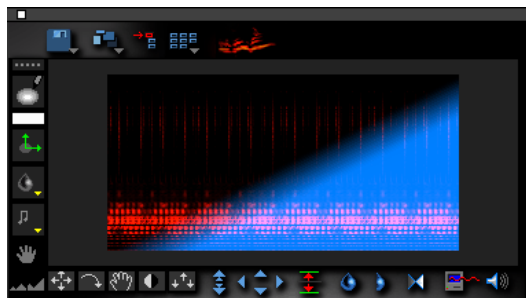

Rhythm 4^a

a. <http://www.atpm.com/6.09/mp3/rhythm4.mp3>

I doubled the pattern’s length before filtering so that the fade in would be more gradual. The resulting sound file might serve as an introduction to a longer work. Todd’s own example, “Beat Study 2,” is available on his [Metascape page](#)¹

at MP3.com. Note the similar, though differently mapped, drum pattern, as well as the use of filters, panning, and some of the synthesized sounds possible in Metasynth.

More Basics

Glen Bledsoe, the founder of the [Metasynthia Project](#)², led the second half of the morning seminar. He demonstrated how to build simple melodies in the image synth through a combination of Scale Maps, the “fit to scale” option, and the various tools in the image synth window. Following along I created [this little sax lick](#)³.

Not bad, but rather inexpressive. Next, Glen demonstrated how to modify the pitch envelopes of each note.



A Simple Vibrato

It’s tedious work, but with a little patience and a lot of sensitivity you can bring some [level of expression](#)⁴ out of preset samples. Layering melodies like these with rhythmic patterns, Glen realized the quirky jazz-influenced compositions he distributes under the pseudonym [Professor Armchair](#)⁵.

Build Your Own Filter

Friday afternoon Eric Wenger demonstrated the numerous graphic tools available in the Image Synthesizer. These tools have many applications in the unique visual/sonic world of Metasynth, one of the most intriguing of which, for me, is filter design. Here is a step-by-step example:



By inverting the black screen while in stereo mode, I produced a yellow screen representing a transparent filter.

1. <http://artists.mp3s.com/artists/139/metascape.html>
2. <http://uisoftware.com/PAGES/index.html>
3. <http://www.atpm.com/6.09/mp3/sax1.mp3>
4. <http://www.atpm.com/6.09/mp3/sax2.mp3>
5. http://artists.mp3s.com/artists/140/professor_armchair.html

Then I applied a preset mono filter to this stereo image, creating a stereo duplicate, mapped equally to the left and right channels.

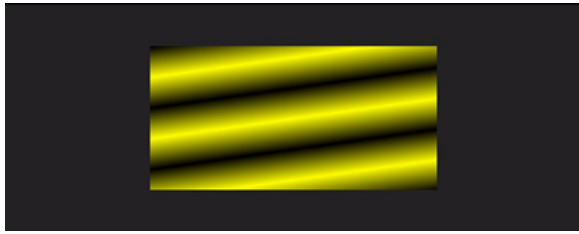

Using the Displacement Map on the left channel only, I distorted it to create a new pattern:

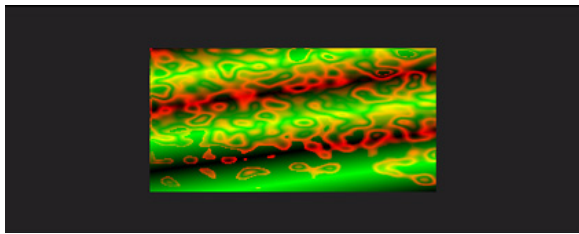

Then I applied a different displacement map to the right channel. The result is a new filter pattern that I can save in a new filter preset file. It's also a pretty cool picture:

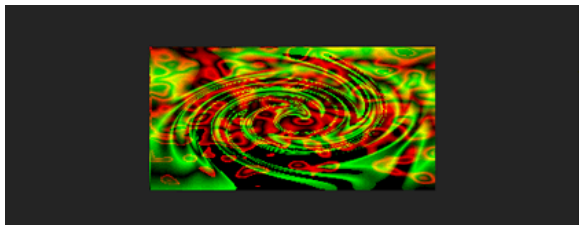

The Quest for a Better E-mail Connection

Unfortunately, Eric's presentation was interrupted by the aforementioned G4 crash. I used the unscheduled break as an opportunity to find the computer lab and check and reply to my e-mail in a more comfortable setting. I didn't plan to stay long, but when I arrived, I found out that the computer lab would be closing at 5:00 PM (it was now almost 4:00) for the weekend. At the time, I thought this would be my only chance to respond to my accumulating e-mail at length (writing in Graffiti tests my patience rather quickly), so I chose to miss the rest of the afternoon session.

I was also exhausted so I went up to my room after dinner and unexpectedly fell asleep. I was late for the evening session, but Todd dedicated the first hour to rudiments, so I was able to begin working quietly on a work of my own, which I will describe in detail next month. I thought that my e-mail problem had been solved, when Edward introduced me to mailstart.com¹, a great site that allows you to check any e-mail account. That worked until halfway through the

Saturday session, when Netscape stopped functioning and ended up crashing my computer. It turned out that the same problem had suddenly struck all the computers, and Todd suspected that the university had blocked Internet access for the weekend. What did I ever do to them?

Saturday—More Tips and Tricks

In between working on my own piece most of the day (I was becoming more and more inspired by all the ideas swirling around me) I caught the highlights of various presentations. Todd built a short piece out of a shakuhachi sample that he made the previous evening, and a simple percussive pop, which he expanded, through added harmonics, into a convincing drum sound. Glen showed how to set up a custom scale in a SimpleText file, either by cents or by acoustic ratios, and open it in the Custom Scale map. (There are 400 scales on the Metasynth CD, by the way). Edward demonstrated various types of analysis/re-synthesis, including a way to build a custom scale out of a harmonic analysis. Finally, Eric demonstrated the many applications of the Blue Channel. We have already seen the Blue Channel at work in our drum grid, but it has many other uses. Perhaps Eric's most striking example was when he took an analysis, copied it to the Blue Channel, then took a second analysis and pasted it to the Blue Channel. The result was a combination of the amplitude envelope of analysis one with the harmonic content of analysis two, or in other words, a vocoder.

Transformation Beyond Recognizability

Part of Edward's demonstration showed the incredible flexibility of the Effects window. Taking a simple sample, a woman reading the text [Welcome to Metasynth](#)², he led us through a series of transformations that gradually distorted this sample beyond recognizability. First he scrambled the sample through [granulation](#)³. (What you hear is actually two passes with slightly different settings.) Granulation can also be used to [stretch](#)⁴ sounds. In Metasynth, the ratio of time change is set by the ratio of output to input. Edward then used [reverberation](#)⁵ to blur the individual grains. After two passes, the result is sufficiently smoothed out. Then he added the following effects: [resonance](#)⁶, which highlights certain harmonics in the sample, and the [shuffler](#)⁷ which scrambles the sample and makes instant rhythmic patterns. Finally, I

-
1. <http://www.mailstart.com>
 2. <http://www.atpm.com/6.09/mp3/voice.mp3>
 3. <http://www.atpm.com/6.09/mp3/effect1.mp3>
 4. <http://www.atpm.com/6.09/mp3/effect2.mp3>
 5. <http://www.atpm.com/6.09/mp3/effect3.mp3>
 6. <http://www.atpm.com/6.09/mp3/effect4.mp3>
 7. <http://www.atpm.com/6.09/mp3/effect5.mp3>

added the [inertia](#)¹ effect myself. It smears and emphasizes the low frequencies, and it is one of my personal favorites.



The Effects Window

Go back now and compare the final MP3 file with the original. Some of the original vocal quality remains, but the material is so distorted that no one could ever guess the exact content of the original. This approach to sample modification has always fascinated me, and I see Metasynth's abilities in this area as one of its strongest points.

1. <http://www.atpm.com/6.09/mp3/effect6.mp3>

Saturday Night—Time to Share

A number of works were presented Saturday night including my own newly realized composition. I will take you through each step of its construction next month, as well as cover the last morning of presentations and relay my impressions of the Videodelic demo. For now, I encourage you to visit the Metasynth site, check out the various audio (Metasynth, Metatrack, Xx) and video (Artmatic, Vidoedelic, Bryce) examples. Further examples by [Eric Wenger](#)², [Edward Spiegel](#)³, Todd Barton, and Glen Bledsoe are available for download on MP3.com.

Next Month: My Summer at Camp—Part Two.

2. http://artists.mp3s.com/artists/114/eric_wenger.html
3. http://artists.mp3s.com/artists/135/eas_electronic.html

Copyright © 2000 David Ozab, dozab@atpm.com. [David Ozab](#)⁴ is a Ph.D student at the University of Oregon, where he teaches electronic music courses and assists in the day-to-day operation of The Future Music Oregon Studios.



4. <http://darkwing.uoregon.edu/%7Edlo>

On a Clear Day, You Can See the Hollywood Sign

by Mike Shields, mshields@atpm.com

I Couldn't See It

I recently received the following e-mail:

Mike:

If you say so. But I don't know of any place in Redondo Beach that has a view (much less unobstructed) of the Hollywood sign.

But, hey, that's what words are for, right?

And I have to admit, he's right—from my apartment in Redondo, there's no good way to see the Hollywood sign, at least from my computer. If I were to crawl onto the roof of my apartment and look north, I could probably see it on a clear day. But I don't have a laptop, and crating an 8500/180 up to the roof (complete with 14" monitor) would be impractical, and would bring complaints from the rest of my family.

A place where I should've been able to see the sign, at least metaphorically, was at the recent ShowBiz Expo. *Variety* magazine puts on this extravaganza twice every year, both near me at the LA Convention Center (near the site of the most recent LA riot-Go Lakers!) and in New York, where I don't live. While there were iMacs at almost every booth that had a computer (green apparently being the favorite color of the industry), Apple themselves were quite conspicuously missing. Sure, Canon was there with their entire range of video cameras (including the XL-1, which I highly recommend), but they didn't have a Mac or even a PC with which to do a demo. The recent Democratic National Convention, held in the same complex, had more iMacs.



I guess I was hoping to see something like this at the Expo. It's my impression that if Apple wants to be first in the DV content arena, catering to the professionals who are actually going to create it should be top priority.

Of course, the recent slew of iMac commercials would have you believe that Apple is counting on individual consumers to create the next *Titanic*. But for every *Titanic*, you get ten *Plan 9 from Outer Spaces*, Sturgeon's Law being what it is, after all. Of course, *The Blair Witch Project* was indeed [edited](#)¹ on second generation Power Macs, but it was not shot on digital video. I've had several discussions on the future of digital video on the various newsgroups and mailing lists that I used to frequent (some I still do, most recently, the MacDV mailing list that I've referred to on several occasions). Most on the Net believe that big-screen DV quality hasn't arrived yet.

And now, for an opposing view: I believe that DV is here to stay. QuickTime is already the *de facto* standard for the Web. FireWire devices proliferate by the day. Web sites featuring short films seemingly pop up by the hour. Check out a few of the more famous: [Digital Papercut](#)², [Atom Films](#)³, [Killernerd.com](#)⁴, and others that I've mentioned previously. And of course, there's Apple's own [QuickTime site](#)⁵.

So, what can we conclude? That I'm right :-)? That I know more than Steve does? Or, does he know more than I do? Both? Neither? Okay, maybe Steve has a better view of the big picture. But this doesn't explain Apple's absence from the upcoming DVExpo.

Elsewhere in the Industry

A recent court case affects all of us, not just those creating content. Several versions on the same story broke last week. I like the one here, which talks about the [legal aspects](#)⁶, without all the Hollywood spin. You can also find variations on the theme at *Wired News*, *Mac Central*, and *MacNN*, among others, and I think even some of the rumor sites covered this one. Then come back. I'll wait.

Okay, I admit it, I've buried the lead. But I'm a columnist—I get to do that. At least until my editor tells me I'm a reporter. To recap, a bunch of guys got together and figured out a way to [play DVD disks](#)⁷ on machines running Linux. Another bunch of guys posted the software on the 2600 eMagazine site. Then the MPAA (read: Jack Valenti) got upset. Lawsuits were filed. Ninety-three-page decisions were

1. <http://www.atpm.com/5.10/hollywood.shtml>
2. <http://www.digitalpapercut.com>
3. <http://www.atomfilms.com>
4. <http://killernerd.com/>
5. <http://www.apple.com/quicktime>
6. <http://legalnews.findlaw.com/news/s/20000817/techhackerdc.html>
7. <http://www.maccentral.com/news/0002/08.mpaa.shtml>

written. The Digital Millennium Copyright Act received its first real test regarding its constitutionality. As of this writing, the best answer I can give is: I don't know.

What I can give is my opinion. Then, of course, you may decide to ignore it, agree with it, or send me an e-mail to tell me why I'm wrong. Or why I'm right.

If I buy a DVD, I should be able to play it on the machine of my choosing, whether that be a DVD player, or a computer with a DVD drive. The software that allows me to do this should be transparent. However, with the advent of the Content Scrambling System, I'm not able to play said DVD on all machines, specifically, if I'm running some version of Linux. Conspiracy theories about Microsoft trying to limit your DVD viewing pleasure aside, according to the MPAA, the pirating of DVDs poses a "serious threat" and costs the organization \$2.5 billion per year. Never mind that during the trial they couldn't come up with a single piece of evidence to support this allegation.

An interesting idea was tried by the defense. Computer code in and of itself is speech, and therefore protected by the First Amendment. This argument related to the code being published on T-shirts and sold. The judge quickly dismissed this notion. It will be interesting to see how the appeal goes. Another part of the judge's decision relates to being responsible for the content of sites to which your site links. This could have far-reaching effects for the entire Web. If I link to your site, and you have a picture of a nude woman on it that I don't know about, I don't think I should be liable for that.

I believe that a few hundred Linux programmers wanting to see DVDs is a good thing. Apparently, the major studios believe that they're a threat to intellectual property rights everywhere. Only time, and perhaps ultimately the Supreme Court, will tell.

Seventy-two and sunny in Redondo.
e you next time.

Copyright © 2000 Mike Shields, Hollywood Guy, mshields@atpm.com.



About This Particular Web Site

by David Spencer, dspencer@atpm.com

MacLotto

Web: <http://www.maclotto.com>

Play the lottery for free!



The name of the site says it all—it's a lottery for Macintosh products. And the best part of the deal is that it's free. All you have to do is go through a simple registration and then pick out six of your luckiest numbers. Winning numbers are drawn every day at around 8 PM, and anyone matching four, five, or all six numbers wins a prize.

Dealmac

Web: <http://www.dealmac.com>

Make better educated purchases.

With so many different Mac products to choose from, it's not always easy to pick out what's right for you. And even when you do find the perfect item, it's hard to know if you're getting the best price around. Dealmac does an excellent job of sifting through all the companies and specs to help you make purchasing decisions.

There are several helpful areas to choose from:

- Dealchat/mac, which is a forum for Macintosh enthusiasts about all kinds of Mac-related topics.
- A consumer page, which helps the consumer deal with disputes.
- Jobs. No, this isn't an area all about Steve Jobs; it's a portal to all kind of Mac-related jobs.

One of the best features of Dealmac is the option to receive an e-mail notification when a good deal is posted. Who defines a "good" deal? You do. Enter in the product and specs you're looking for, and when it is posted on Dealmac, you'll receive notification via e-mail immediately.

OpenTable & Foodline

Web: <http://www.opentable.com> & <http://www.foodline.com>

Restaurant Reservations all around America.

Both of these sites offer the same service—restaurant reservations. You can choose from a variety of US cities and then select from many different restaurants. Obviously neither site has every restaurant in all of the cities, but by having both sites bookmarked you'll have a lot more restaurants to choose from. You can make reservations for between two and two hundred people.

EarthCam

Web: <http://www.earthcam.com>

Live webcams from all around the earth.

From the Big Brother cameras to the USS Intrepid, EarthCam puts you in touch with all kinds of webcams around the world. The interface has a Yahoo-ish familiarity to it, all centered around webcams. The site is clean and fast, making this one of my favorite webcam portals.

VersionTracker

Web: <http://www.versiontracker.com>

How the heck do I keep up with new versions of my software?



This is one of the most valuable Mac resources on the Net. With an enormous number of software titles out there, it would be a full-time job to keep track of which software titles have been updated. VersionTracker does just that, keeping tabs on just about every Macintosh software title. You can check the Web site for updates or receive them via daily or weekly e-mails, which are an amazingly helpful tool for staying on top of software updates.

Copyright © 2000 David Spencer, dspencer@atpm.com. David Spencer has been a Mac advocate since 1991, when he traded in his IBM PC Jr. for a Mac Classic.



Part VI: The Animated GIF

Following last month's column on the [GIF file format](#)¹, this month I'll be covering animated GIFs. An animated GIF is one way of creating a moving image on your Web page. In my opinion there are two reasons why you may want to use animated GIFs on the Web, and a million reasons why you shouldn't.

Reasons to use them:

- To draw attention to something.
- To demonstrate how something works (e.g. how a steam engine works).

Reasons not to use them:

- They rarely add any benefit to the page.
- They take a long time to load.
- They can make your Web site look amateurish and unprofessional.
- They're often distracting.
- If, say, I want to call your company and I see an animated GIF of a phone next to your phone number, I won't phone you.

OK, that's only five, but I'm sure you all have a few more. I'm not saying animated GIFs are all bad, but there are a lot more examples of bad ones than good ones.



Your eyes are naturally drawn to anything that moves. Imagine settling down to read your favorite daily newspaper and finding at the bottom of the page a little guy jumping up and down, trying to put an envelope in a dancing mailbox. Now, are you going to be able to concentrate on the article?

Possibly not. Unless an animated GIF complements the information your page, don't use one.

An animation draws your eyes to it. How can that be used to our advantage on our Web pages?

- *Advertising Banners:* If you want people to click on your banners, animating them makes them much more likely to be clicked on. Watch that cash roll in!
- *What's New/ Featured article:* People often re-visit Web sites to find out if anything has changed since they last came. If you have an animated "What's New" button then they can instantly see what has changed.

So, as animated GIFs have their good points and bad points, you need to decide whether or not you use them. If you do want to use them, you'll need to know a bit more about them. Here's a short tutorial on creating an animated GIF.

Tutorial

We're going to be using a program called Web Painter, but most of the information can be used with any other package. The reason we are using Web Painter is that it has been given away as a full package on many magazine CDs, so the hope is that many of you will have a copy of it. If not, a demo of the latest version is available from this [Web site](#)².



1. <http://www.atpm.com/6.08/graphicsandtheinternet.shtml>

2. <http://www.totallyhip.com>

We're going to make simple banner for the ATPM Web site. Before even turning your Mac on (or waking it up) get a pen and paper and sketch out your ideas for your banner. You can make things a lot easier with advance planning. Here's our story board for the ATPM banner (see above).

We'll start making a new file, by going to the File menu, and then choosing New.... As we are making a banner, we'll choose a standard banner size of 468x60 pixels.

Web Painter lets us choose a background image for our animation. To edit the background, choose Goto > Background from the Cel menu. You can then either draw your background image or import one from another package. I have drawn some dodgy-looking iMacs and added some text ("About This Particular Macintosh"); these items will be static throughout the animation, so they are ideal for the background.

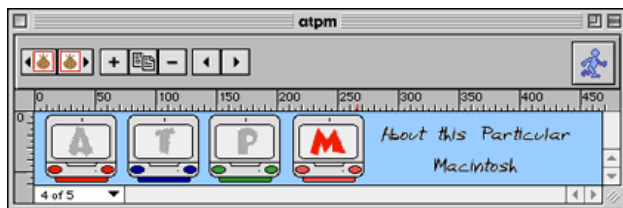

Animations are made up of cels. Each cel has a slightly different image than the one before. When the cels are played in quick succession the illusion of movement is created. If you've ever drawn a stick-person on the corner of every page in a book and flicked through the pages, you'll be familiar with the system.

At the moment we have a background image and one cel. Obviously our animation is going to be bland with just the one cel. We need four overall, so go to the Cels menu and choose Add Cels.... As we already have one cel, we only need to add three more.

Now, let's add the animation part to our animated GIF. If you are not already on the first cel, choose Goto > First Cel from the Cels menu.

In the first frame of the animation, we want the 'A' to glow red. Select the text tool and make a red 'A'. We can then drag this into position on top of the grey 'A'.

Select Goto > Next Cel and repeat the process with all the other cels.

When we've done this, we can check how it looks so far by selecting the Play button on the controller. If the controller window is unavailable, choose Show Controller from the Window menu.

Now, let's make this into an animated GIF. From the File menu, choose Export > Animated GIF file; a dialog box will pop up with a whole bunch of options. These options are essentially the same as in most packages; many of the options are similar to the standard GIF saving options, so refer back to [last month's column](#)¹ for details about them.

The Options

Repetitions

How many times your animation loops. You can choose to loop the animation forever and ever and ever...

Frame Delay

This alters the amount of time you get to see each frame for. You can select a separate time for each individual frame or choose the same time for every frame.

Do Not Erase

The current graphic will remain while the next cel draws.

Erase with Background

The current graphic is erased with the background before the next cel draws.

Erase with Previous

The current graphic is erased with the previous cel before the next cel draws.

Changed Area Only

The cels in the GIF will only change in the areas where the animation takes place. If you de-select this box and choose "erase with background" you can create transparent backgrounds.

The HTML

When you click "Save," Web Painter helpfully generates HTML to link to the animation. You are given the option to save this to the clipboard or as a text file, which I think is an excellent feature. To link to an animated GIF in HTML, you use the same method as you would a normal GIF:

```
<IMG SRC="mybanner.GIF" WIDTH=468 HEIGHT=60 BORDER=0>
```

The WIDTH and HEIGHT attributes tell the browser the size of our banner. The BORDER element tells the browser not to put any border round the banner, an option you'll want to exercise regularly.

Open SimpleText or BBEdit and type the above HTML line in, substituting "mybanner" with the name of your file. Save the HTML with the name "test.html".

Checking it All Works

Now we need to test it. Fire up your favorite Web browser and open your test page. Provided you own a reasonably modern browser, you should see your animated banner in all its glory. If you make any changes to your image, reload the page in

1. <http://www.atpm.com/6.08/graphicsandtheinternet.shtml>

your browser when you test it, to be sure you are looking at the most recent version.

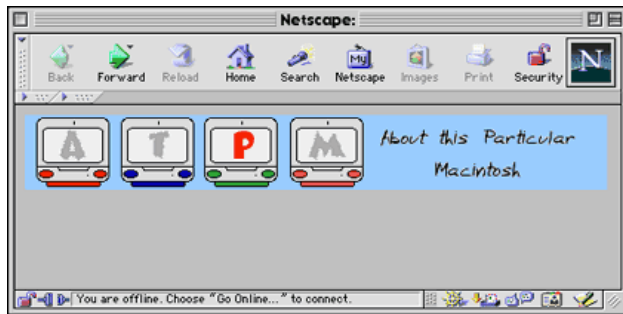

Some older browsers can't handle animated GIFs and will only display either the first or last image. Bear this in mind if your Web site caters for people who may use old equipment or software; schools and clubs, for instance, often can't afford to upgrade.

Guidelines

Although this tutorial was based on Web Painter, most of the techniques are universal and apply to many other packages such as Fireworks. Regardless of what you make the animation in, however, remember the following:

- Big obvious changes from one frame to the next work better in GIF animation, although subtlety is lost.
- Don't use an animated GIF when it's not needed.
- When choosing how many times an animation should loop, stick to two or three. It can be off-putting if the image jumps about for ages in the corner of the page.
- Don't use an animated GIF when it's not needed.
- Animating only part of the image (instead of the whole image) will reduce file size.
- Don't use an animated GIF when it's not needed.

Useful Links and Software

[Animated GIF Artists Guild](#)¹

1. <http://www.agag.com/>

Copyright © 2000 Grant Osborne, gosborne@atpm.com.

[GIFBuilder](#)²

This program turns the layers from a Photoshop file into the cels in an animated GIF. Wow!

[Animation Online](#)³

This Web site lets you create animated banners online

[GIFcruncher](#)⁴

Shrink those GIFs.

[Animation Factory](#)⁵

Over 12,000 GIF animations!

I've not included many links to clip-art sites, as many of them aren't all that good. You'll find links to the ones that *are* on everyone else's Web sites anyway. Happy Animating!

...

Next Month

Next month we will be looking at things that look really bad on Web pages, including psychedelic backgrounds, really tiny text, blinking text, animated hands writing "welcome," stupid JavaScript balls that follow your pointer...

Oh, scrolling text as well, music when I'm not expecting it and much, much more.

If you know of any Web graphic crimes, or would like to suggest a topic for a future column e-mail me at gosborne@atpm.com.

For reference purposes, here is what I have planned so far:

October

Things That Look Really Bad On Web Pages

November

Web Page Design Tips

December

PNGs—Future Or Failure?

Thanks for reading. I'll see you next month.

2. <http://www.mac.org/graphics/gifbuilder/>
3. <http://www.Web-animator.com/>
4. <http://www.gifcruncher.com>
5. <http://www.animfactory.com>



Segments: Slices from the Macintosh Life

by Matthew Glidden, mglidden@atpm.com

Why My Next Mac Will Be a Cube

The only room for expansion is in my mind...

The introduction of Apple's new Mac, the Cube, sparked two immediate questions: "How *do* they think of these things?" and "Who the heck is going to want one?" The first question is one of respect for design intuition and skill. The second question is, well, at least slightly critical of *marketing* intuition and skill. Like most new Apple products, however, the Cube makes more than a technological statement of, "Look at me! I'm small!" In a market whirling with bulk and complexity, the Cube is a welcome breeze of conceptual simplicity. Who wants one? I do, for both utilitarian and—dare I say it—philosophical reasons (at least in a computer sense).

Computer design is like Dr. Dolittle's pushme-pullyou beast, simultaneously seeking the opposing goals of contextual simplicity and computational power. (Computer people often use the pushme-pullyou as a work metaphor, delighting in its childish image of competitive capitalism and paradoxical nature in a field ruled by logic.) Power typically wins out, producing a panoply of bulky desktops. Simplicity typically comes at the expense of function, shown by the current crop of handheld devices. The Cube strikes an impressive balance, eliminating the cumbersome (bulk, wires, noise) but preserving the power.



© 2000 by Jamal Ghandour

If you haven't read about the Cube before, here's a quick summary of the first week's worth of news articles and speculation: "Blah blah, 8-inch cube, blah blah, noiseless—no fan, blah blah, no PCI slots?, blah blah." For the technical details, see the [Apple.com Cube page](http://apple.com/cube/page)¹.

I mentioned computing philosophy earlier, as I consider the Cube a new generation of simpler high-end computers. With the exception of the 20th Anniversary Mac (which certainly set the precedent), "big" dominates high-end computing. Big boxes with big expansion, big processors, big disks, and big memory. They have their audience, but big boxes also have big baggage. You have to make space, debate over video cards and storage options, and match the curtains (well, Mac users do). Beyond its physical simplicity, the Cube offers mental simplicity, something that's high impossible to find in a high-end desktop.

Mentioning simple design, however, begs the question, "Why not an iMac?" It has similar features, simple expansion, and a lower price tag than the Cube. There are two reasons, one clear and one subtle. The clear one is the monitor, as a new monitor would mean a new iMac. I like my 17" Studio Display and will probably switch to LCD within a year. The subtle reason feels vaguely elitist, but as a "power user" (note the meaningful anagram: "super ower") I couldn't replace my Power Mac 8500 with an iMac for the same reason I won't go from an old RX-7 to a new Jetta. As this point in my computing life, I want that extra *joie de vivre*.

So is there a downside?

After five years, I'm accustomed to a multi-monitor desktop. My Power Mac 8500 can use two displays out of the box (monitor and video-out). For home video production, I used *three* at a time by adding a video card. The video days have passed, but the monitors remain. That's my sole "con," as the Cube only supports one monitor (until someone makes a specialized Cube video card). It's not a big downside, however, since I reclaim the second monitor's desk space and power consumption (and taste, as the second monitor is beige).

The monitor sacrifice brings up the Cube's lack of internal expansion, which caused some soul-searching on my part. (A rarely admitted geek trait is the need to "soul-search" to make computer-related decisions.) It took me five years to fill my 8500's three PCI slots with 3D graphics, 100BaseT Ethernet, and USB cards, all functions that come *standard* on new

1. <http://apple.com/powermaccube/>

Macs. I have two peripherals, a cable modem and a venerable StyleWriter 1200 that screams to be replaced. Internal expansion *used* to be a requirement for me, but in the name of simplicity I'm glad to see it go.

With all this talk about design simplicity, you may wonder if I think the Cube is "the way things ought to be" (quoting Rush Limbaugh for the only time in my life *ever*, I promise). The answer is definitely "no," as computers are still huge intellectual leaps away from being what they can be. The Mac

desktop can organize files topically, but it can't dynamically contextualize. A mouse eases navigation, but limits you to two-dimensional input. A processor can perform virtually limitless calculations, but requires a significant amount of space and energy. Software helps us perform cumbersome tasks efficiently, but can't do anything without being explicitly programmed. While the Cube certainly isn't the final answer on any of these points, its progress in design clarity and concept unquestionably make it my next Mac.

Copyright © 2000 Matthew Glidden, mglidden@atpm.com. Matthew Glidden is the webmaster of Threemacs.com¹, a guide to constructing and maintaining home and small-office Macintosh networks. He can also tango and juggle, not necessarily at the same time.



1. <http://www.threemacs.com>

Extras: Cartoon

by Michael Morgan, mrspiffy@earthlink.net

The "In Your Dreams" Dept.



Copyright © 2000 Michael Morgan, mrspiffy@earthlink.net.



Extras: Desktop Pictures

Mark Montgomery's Desktop Pictures

"A majority of [these images](#)¹ were shot with either an Mamiya RB67 medium format with Fuji film (both chrome and negative) or a Pentax 35mm with various lenses (including macro, 25mm, 80mm and 200mm) again using Fuji products on the film end. A couple of them were made with a 1929 Ikoflex (featured in one of the shots), which is a medium format camera my grandfather used in World War II.

"I make images whenever possible, and make part of my living doing so (mostly photographing recording artists in Nashville). I love to make images of nature, to try to capture a moment the viewer can see and feel a part of. I also love to make images of people and situations. One of my favorite photographers is Henri Cartier Bresson ([link 1](#)², [link 2](#)³).

"Give me some [feedback](#)⁴; I'd love to hear from you!"
—Mark Montgomery

Konstanz Part II

[These photos](#)⁵ by [Jens Grabenstein](#)⁶ were taken with a Canon EOS 300 using a 28–80mm zoom lens and 200 ASA 35mm Kodak film. Most of the photos were taken in the surroundings of Konstanz, a small town located in the south of Germany, close to the Swiss border. The photos were developed and digitalized using [Kodak PhotoCD technology](#)⁷. Resampling and re-touching were performed with [Adobe Photoshop 5.5](#)⁸.

Previous Months' Desktop Pictures

If you haven't seen the rest of the series, it includes: [Yellowstone National Park](#)⁹, [Drops](#)¹⁰, [Toronto](#)¹¹, [Niagara Falls](#)¹², [Monaco](#)¹³, [Montréal](#)¹⁴, [Bahamas](#)¹⁵, [Clouds](#)¹⁶, [Aerial](#)¹⁷, [Made with Macs](#)¹⁸, [Landscapes](#)¹⁹, [Northwest](#)²⁰, [Animals](#)²¹, [Spring Flora](#)²², [National Parks](#)²³, [Insects](#)²⁴,

1. <http://www.atpm.com/6.09/montgomery/>
2. <http://www.mbam.qc.ca/expopassees/a-cartierbresson.html>
3. <http://www.npg.si.edu/exh/cb/index.htm>
4. <mailto:marko@echomusic.com>
5. <http://www.atpm.com/6.09/konstanz2>
6. <http://www.grabenstein.de>
7. <http://www.kodak.com/global/en/consumer/products/pictureCD/pc/>
8. <http://www.atpm.com/6.07/updates.shtml>
9. <http://www.atpm.com/5.03/yellowstone.shtml>
10. <http://www.atpm.com/5.05/drops/>
11. <http://www.atpm.com/5.07/toronto/>
12. <http://www.atpm.com/5.08/niagara/>
13. <http://www.atpm.com/5.09/monaco/>
14. <http://www.atpm.com/5.10/montreal/>
15. <http://www.atpm.com/5.11/bahamas/>
16. <http://www.atpm.com/5.12/clouds/>
17. <http://www.atpm.com/6.01/aerial/>
18. <http://www.atpm.com/6.02/madewithmacs/>
19. <http://www.atpm.com/6.03/landscapes/>
20. <http://www.atpm.com/6.04/northwest/>
21. <http://www.atpm.com/6.05/animals/>
22. <http://www.atpm.com/6.06/spring-flora/>

[Konstanz](#)²⁵, [Mark Montgomery's Desktop Pictures](#)²⁶, and [Konstanz Part II](#)²⁷.

Downloading all the Pictures at Once

iCab and Interarchy (formerly Anarchie) can download an entire set of desktop pictures at once. In iCab, use the Download command to download "Get all files in same path." In Interarchy, use HTTP Mirror feature.

Contributing Your Own Desktop Pictures

If you have a picture, whether a small series or just one fabulous or funny shot, feel free to send it to editor@atpm.com and we'll publish it in next month's issue. Have a regular print but no scanner? Don't worry. E-mail us, and we tell you where to send it so we can scan it for you. Note that we cannot return the original print, so send us a copy.

Placing Desktop Pictures

Mac OS 8.5 and Newer

Go to the "Appearance" control panel. Click on the "Desktop" tab at the top of the window. Press the "Place Picture..." button in the bottom right corner, then select the desired image. By default, it will show you the images in the "Desktop Pictures" subfolder of your "Appearance" folder in the System Folder, however you can select images from anywhere on your hard disk.

After you select the desired image file and press "Choose," a preview will appear in the Appearance window. The "Position Automatically" selection is usually fine. You can play with the settings to see if you like the others better. You will see the result in the little preview screen.

Once you are satisfied with the selection, click on "Set Desktop" in the lower right corner of the window. That's it! Should you ever want to get rid of it, just go to the desktop settings again and press "Remove Picture."

Mac OS 8.0 and 8.1

Go to the "Desktop Patterns" control panel. Click on "Desktop Pictures" in the list on the left of the window, and follow steps similar to the ones above.

23. <http://www.atpm.com/6.07/national-parks/>
24. <http://www.atpm.com/6.08/insects/>
25. <http://www.atpm.com/6.08/konstanz/>
26. <http://www.atpm.com/6.09/montgomery/>
27. <http://www.atpm.com/6.09/konstanz2>

Random Desktop Pictures

If you drag a folder of pictures onto the miniature desktop in the Appearance or Desktop Pictures control panel, your Mac will choose one from the folder at random when it starts up.

DeskPicture

An alternative to Mac OS's Appearance control panel is Pierce Software's DeskPicture, [reviewed](#)¹ in issue 5.10 and available for [download](#)².



1. <http://www.atpm.com/5.10/roundup.shtml>
2. <http://www.peircsw.com/DeskPicture.html>

Review: DoorStop Personal Firewall 2.0

by Paul Fatula, pfatula@atpm.com

Developer: Open Door Networks

Web: <http://www2.opendoor.com/doorstop/>

Price: \$59 (free for EarthLink DSL users)

Requirements: Power Mac with Mac OS 8.1 or greater.



With more personal computers being left online 24 hours a day, the desire, if not need, for a firewall of some sort is on the rise. Like [NetBarrier](#)¹, DoorStop offers Macintosh users protection from the network. However, the similarity ends there. With a very different user interface and a feature set that sticks to the basics, DoorStop will likely appeal to novice Mac users.

Setup

Setting up DoorStop is astoundingly simple, in part because, at least in the Basic mode, there is so little you can configure. You can allow or deny access to Web sharing, file sharing over TCP/IP (DoorStop does not protect AppleTalk, but the typical home user really doesn't need to worry about attacks from there), or everything else. By default, access to everything is denied to everyone, so unless you are hosting Web pages or sharing files, you may not have to do any setting up at all.

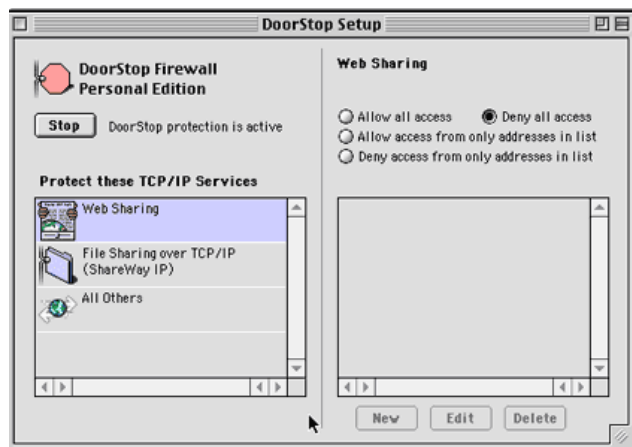

Access to each of these services can be granted to the entire network (good for Web sharing) or limited to specific sites or computers. You can give DoorStop a list of IP addresses to either allow or reject, and subnets are accepted as well as individual IP addresses. DoorStop will even help you find the IP

address of a site or ISP if you don't know it, so you can add it to your Allow or Deny list. Simple, simple.



You probably have a lot of "what if I want to..." type questions in your head right now; what I've described above is great as far as it goes, but let's face it, there aren't a lot of options there. When they say Basic mode, they mean it! One quick change in the preferences to Advanced mode, and DoorStop gains a good deal more functionality while remaining drop-dead simple to configure.

When you move to Advanced mode, you gain the ability to protect other ports. DoorStop has a drop-down menu with some common ports you might want to protect, such as Retrospect Backup, FileMaker Pro database hosting, and the omnipresent Napster. If you want to control access to some other port, it's as simple as typing in the port number. Ports in DoorStop's dropdown menu have easily identifiable icons

1. <http://www.atpm.com/6.07/netbarrier.shtml>

associated with them, making it easy to see at a glance what you're protecting.

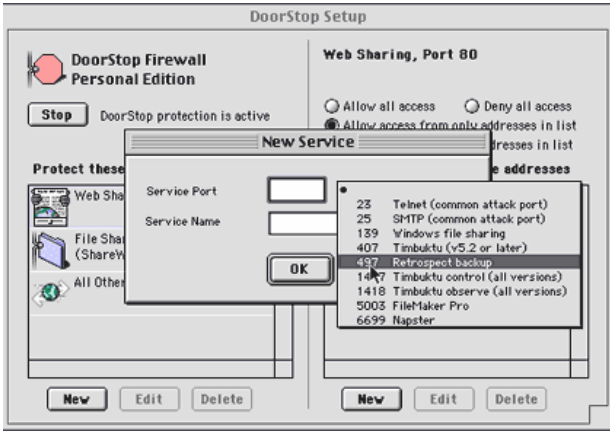

It would be nice if you could ask DoorStop to inform you only of allowed/rejected accesses to specific ports or services. In my case, I often have people access the FileMaker Pro port, so I don't really want to be notified every time it happens; but on the other hand, granting access through other ports, such as File Sharing, happens more rarely and it would be nice if I could get notification when that happens.

As far as I can tell, DoorStop logs everything. Preferences allow you to have it record allowed and/or denied accesses.



Advanced mode also gives you a little bit more control in specifying subnets, although you still cannot specify a range of IP addresses within a subnet, like 198.0.0.4–198.0.0.85, meaning you might have to either spend a while adding lots of individual addresses to your access list, or allow in some unwanted traffic.

You can also protect UDP ports when you're in Advanced mode, though the manual makes it clear that this is generally unnecessary and could have undesirable side-effects. The manual tells us that UDP ports are used basically by the system, for things such as DNS lookup and NTP (setting your clock over the network). You can also choose to log UDP port access, but again, you're unlikely to need to do that. This feature was likely added just for completeness, and DoorStop does a good job explaining it in the documentation and keeping it a separate option in Preferences, so it's unlikely a user will accidentally cripple his network access by turning off UDP access.

Just to let you feel completely safe about your setup, DoorStop also has a Self Test feature: it can try to access your computer, through any port you select, from either your own IP address or any other one you type in. It's hard to decide how I feel about this feature: on the one hand, it's wholly redundant: you can get the same information the Self Test provides you by looking in your Setup window. However, it definitely confirms your feeling of security when you test your firewall and get back a message letting you know it's working. A firewall program, especially on a personal Mac, is largely about feeling secure, and the Self Test definitely helps you to feel safe and protected.

Log

Once DoorStop is set up, you can pretty much forget it's there. You can ask it to inform you of allowed and/or denied accesses, but in practice I find this is unwise, as at least in my case, I'd be getting a lot of notices popping up on my screen.

The log window puts in boldface any access attempts recorded within the last fifteen minutes, which you stick out when you open the log. The log window looks just like a Finder window, and, better yet, it functions just like one, too! Click on the header of your choice, and the list sorts in that order. However you sort, the most recent access attempts stay in bold, which is a really nice touch: you can scan the list and find out about times in the past when a particular host has tried to access other ports on your machine. Double-clicking on a line opens a window which basically duplicates the information you can see in the log, but it also gives you a "Learn More..." button. Press this and your Web browser opens with information about that particular access attempt. Unfortunately, the Web page doesn't load with iCab (this doesn't seem to be an issue with my iCab preferences, but with as configurable a program as iCab, it's hard to rule that out with certainty), but it works fine with Internet Explorer 5.

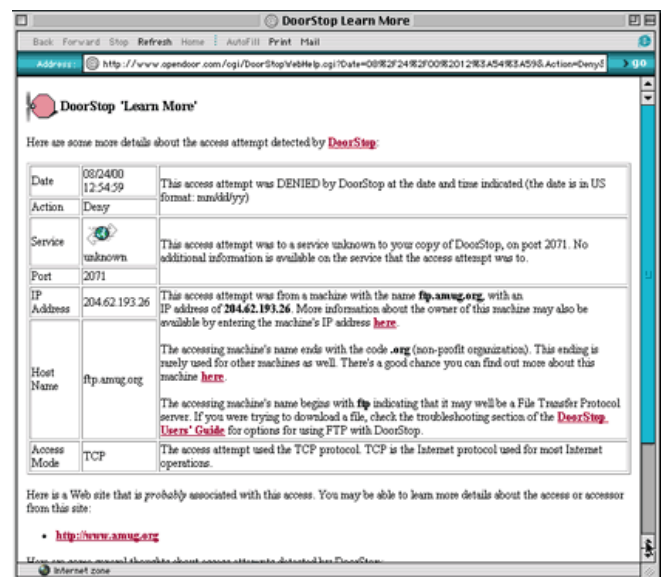

The log's Internet integration is one of the greatest strengths of DoorStop. It means that you don't have to be a networking guru to satisfy your curiosity about who is trying to access your computer.

Flaws

While DoorStop is a very impressive product, it's not without its shortcomings. Keeping in mind that it's not a power-user type of program, but one that keeps the basic needs of the average user in mind, there are two points that really could use some improvement:

In the case of the denial of access shown above, the program's FAQ is helpful in pointing out the problem, but it also highlights a shortcoming of DoorStop. One of the questions the FAQ addresses is, "I go to download a file and DoorStop logs an access attempt. What's going on?" Unfortunately, DoorStop doesn't play well with FTP. If you try to download a file using FTP when DoorStop is on, you'll get an error from the server you try downloading from. This is because (the FAQ explains) DoorStop denies the FTP server access to a random port it attempts to access on your machine. The best DoorStop can do is offer a workaround:

temporarily turn DoorStop off (a control strip menu lets you turn it off for a set amount of time). In practice, this is just a pain. Worse, I often end up turning DoorStop off permanently when I have lots of files to download, and then forgetting to turn it back on again when I'm done. Ideally, DoorStop should be completely transparent to the user.

The other shortcoming of DoorStop is that it does not protect against ping flooding. The only time I've encountered ping flooding has been from malicious people on IRC, so this may not be an issue for you. However, ping flooding can severely slow your network connection, so at the very least, protection against this would be a great feature to add to the next version of DoorStop.

Conclusion

DoorStop is a remarkably simple program. It has a single function and performs it quite well. Its user interface is great, the manual is well-written and helpful (though it's only in HTML, so if you want a printout, it'll be a pain), and for the most part, the program is completely transparent. There is a free ten-day trial available, and I'd encourage you to give DoorStop a shot.

Copyright © 2000 Paul Fatula, pfatula@atpm.com. Reviewing in ATPM is open to anyone. If you're interested, write to us at reviews@atpm.com.



Review: Gerry's ICQ d44.1

by Daniel Chvatik, dchvatik@atpm.com

Developer: Gerry Beggs

Web: <http://homepage.mac.com/gerrysicq/>

Price: free

Requirements: Mac OS 8 or later, Internet connection.



The Internet is about the efficient and reliable transmission of information among many interacting parties. The information may be pictures, movies, programs, text, credit card information, or simple messages. But the keys are often reliability and efficiency (and sometimes security). E-mail was one of the first applications on the Internet, and its benefits quickly become clear: fast and convenient transmission (nearly free of charge), the ability to send (or forward) the same information to multiple people with marginal effort, and much more make e-mail a sure win over traditional "snail mail." With e-mail, it takes only minutes to send a letter, compared to days or weeks for postal mail. Yet e-mail isn't perfect (and I don't mean the lack of a personal touch—and no, HTML e-mail doesn't fix that!).

Two disadvantages of e-mail stand out: its slowness and the lack of instant feedback. Wait a minute, didn't I just praise e-mail for its speed? Yes, compared to snail mail. But as they say, everything is relative. With e-mail, it usually takes *at least* several minutes for one message to travel from one person to the other. Pure transmission speeds often aren't the problem. But few people check their e-mail every minute. Besides being dangerous (because your password is transmitted in plain text each time, and so theoretically is a very easy target for hackers), it requires everyone to be online all the time.

However, let's assume the optimal case: two people with fast, dedicated connections, both online, both checking their e-mail every minute. Even then, it will take more than a minute to get a reply from one person to the other. Say person A sends an e-mail to person B. Transmission will likely be quick, let's say 2 seconds. However, because person B only checks once a minute, it will take 30 seconds (on average) for the next check. Getting the e-mail from the server will take another second. Then person B has to open it, read it and reply to it. Let's say that takes 10 seconds (very optimistic). B sends the reply out again (another 2 seconds). Person A checks every minute, so it takes another 30 seconds to get the e-mail and 1 second for the download. The grand total: 75 seconds.

Now imagine calling someone to discuss something. If you have to wait 75 seconds after you speak to get an answer back, this conversation will take a long time. 75 seconds doesn't sound like long, but if everybody only makes 30 statements (or 60 statements together), your little talk will take 1 1/4

hours without anyone saying much. This is simply impractical for a chat or a longer discussion. Of course, you could use the phone, but that's costly.

The answer? Internet chat. Here again, there are several options. IRC (Internet Relay Chat) is one. AOL Instant Messenger is another, but today we will talk about ICQ, Gerry's ICQ that is. For more information about Gerry and the story behind the program, you can read our [interview](#)¹ with him. Today it's about the program itself.

Actually, there isn't much to say about a chat program. In the end, all it lets you do is chat. It's like talking a lot about a telephone: it's all in the extras, and Gerry's ICQ has a lot of those. One of them is a log function. It saves the last bits of conversation that you had with each person, in addition to a time stamp, so you know exactly what you said, when (no more arguing about what you said!). Like most aspects of Gerry's ICQ, this feature is very configurable.

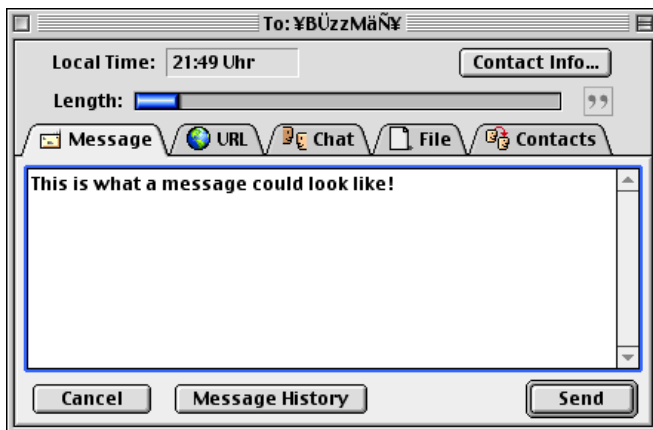

The "traditional" ICQ-style chat was message based, meaning you send some text to your chat partner, he gets the entire message, reads it and replies, at which point you get to read his reply. Now Gerry's ICQ also supports IRC-style chat, i.e. you see what the other person types before he has even finished the message. This has the advantage of allowing you to work on your reply before the other person has finished his sentence.

1. <http://www.atpm.com/6.07/interview.shtml>

Well, okay, I was wrong before—there’s more to say about Gerry’s ICQ than about a telephone. That’s because ICQ wasn’t really a “chat” application to begin with, and more of a messaging system. This is reflected in Gerry’s ICQ. You can chat with someone (which requires the other person to be online and accept your chat request), or you can simply send a message. This is actually quite like e-mail, except that it’s much faster. Once you get an ICQ message, the program notifies you in several ways (among them a flashing control strip module!) and allows you to read the message and reply.

The “status” concept ties into the second disadvantage of e-mail that I called “lack of instant feedback.” You can send an e-mail to someone, but you’ll never know if that person is actually there and has read it until you get an answer back. With Gerry’s ICQ, you can build a “Buddy List”-like contact list that shows you who is online or offline (or occupied, etc.), allowing you to know whether it is futile to send an urgent message at a particular time. This whole list is very configurable, as we’d expect, allowing the program to speak people’s names as they change their status, etc. (the name used for the spelling can be changed, for example, to sound more phonetically correct). For important people, I even have Gerry’s ICQ notify me through Apple’s Notification Manager so I don’t miss when they come online.

ICQ has developed beyond simple talk, and Gerry’s ICQ reflects that. In addition to messaging and chatting, it lets you send files or URLs (for simple one-click activation). Or you can send selected contacts to another user, allowing that user to pester your friends as well. As I have mentioned a couple of times, Gerry’s ICQ is *extremely* configurable, even allowing you to change icons, sound effects, and background images. Another great feature is the support for multiple users.

As nice as Gerry’s ICQ is, it’s too easy to forget that it is still in a development version and, as such, it is neither 100% bug proof (then again, no program is) nor feature complete. “Essentials” such as chatting with multiple people at once or a more flexible buddy lists are still missing (although Gerry knows about them, and you can track his progress on the [to do list](#)¹). I had some problems with Unreal Tournament (and now the UT engine-based Deus Ex) and Gerry’s ICQ. Running the two at the same time did weird things to Gerry’s ICQ, such as causing it to send blank messages.

Nevertheless, Gerry’s ICQ is a great program for those who want to communicate quickly, stay on top of their family chit-chat while away, or organize an online game. It isn’t perfect, but it certainly beats the “original” ICQ client for Mac (which is far inferior, except for its ability to chat with several people at once). Oh, and it’s free! And unlike AOL’s Instant Messenger, it doesn’t display ads (okay, you can patch AOL to get rid of the ads, but I bet that violates the end-user agreement). If you haven’t tried Gerry’s ICQ yet, give it a try. It may save you a lot of time—or help you waste a lot of time chatting.

1. http://homepage.mac.com/gerrysicq/to_do_list.html

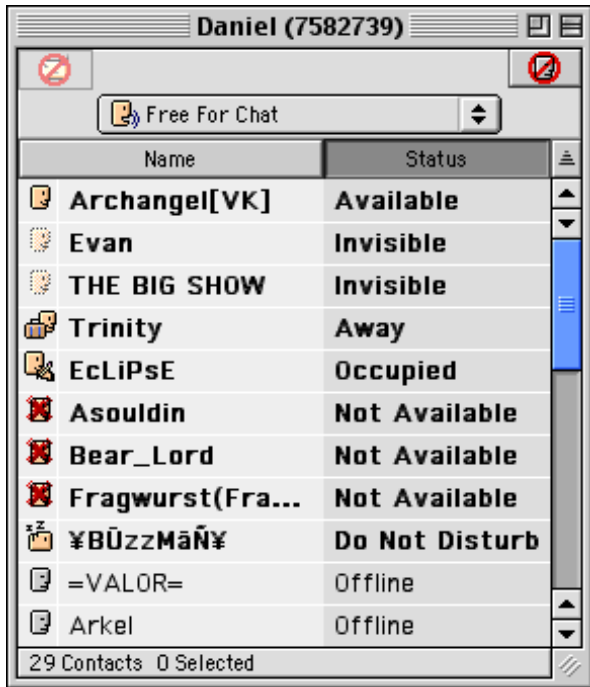

The control strip module also has the function to change your “status.” You might not always want to talk (or at least not to everyone). So you can change your status from states such as “Online,” “Offline,” “Occupied,” and “Away” to more eccentric ones like “Invisible.” The away and busy states are accompanied by editable messages, kind of like a phone answering machine. The invisible state is different, in that it allows you to appear offline to everyone, except to a few lucky people you’ve put on your list (who will see you as online, even if you’re invisible). Similarly, you can put nasty people on an invisible list, so they’ll never know you’re online—or you can simply block them.

Copyright © 2000 Daniel Chvatik, dchvatik@atpm.com. Reviewing in ATPM is open to anyone. If you’re interested, write to us at reviews@atpm.com.



Review: icWord 1.0

by Brooke Smith, bsmith@atpm.com

Developer: Panergy

Web: [Download from ZDNet](#)¹

Price: \$20 (shareware)

Requirements: Mac OS 8.5 or later.



Ever wonder how to read Microsoft Word documents if you don't have Microsoft Word? Well, icWord is here to help.

At only 4 MB, icWord is a file-reading program that allows you to open Microsoft Word documents from either the Mac or Windows platform without Microsoft Word. Word documents from the Internet, a disk, or e-mail open up in WYSIWYG format. According to the program's documentation, icWord opens Word 2000, Word 98 for the Macintosh, Word 97, Word 7, Word 6, and Word 2 documents, as well as RTF files. (More on RTF files later.) Be aware, however, that opening a document in icWord does not allow you to manipulate the text.



WYSIWYG

How it Works

To open a document in icWord, simply drag your Word file onto the icWord icon (or, open icWord, select Open from the File menu, and choose your Word document). The document will open in the format in which the document was saved—almost, that is. Columns, for example, do not show as columns, but appear one column after another. Similarly, although most drawings are shown in icWord, some free-form drawings do not show.

icWord purports to open the “.doc” format from various Word programs, but there is a caution in the documentation file that says: “The better formats are Word 2000, Word 98 for the Macintosh, and Word 97. Use the RTF format only when

you have no other choice.” I don't know why RTF format is even mentioned, however, because I couldn't open RTF. I got translation errors instead.

Despite the inability to read RTF files, icWord seems to work quite well. I printed several Word 98 documents right from icWord and had no complaints. To print (similar to Word itself), click on the printer icon or choose Print from the File menu. A print options box appears, with familiar Word choices: number of copies, which pages to print, ink selection, etc.

icWord's simple yet eye-catching toolbar contains various icons, most of which are self explanatory. From the left, there's the printer icon and the copy icon, then a flashlight that represents Find. Click on this icon to find a word in the text. Of course, you can also choose Find from the Tools menu or use the keyboard shortcut.



The Toolbar

Next is a group of three spyglass icons for altering the document view. The first spyglass changes the relative size of the document from 25% to 400%. The second spyglass (with a minus sign) zooms out, and the last spyglass (with a plus sign) zooms in.

The next set of icons (four blue squares with white triangles on their sides) allows you to jump to the first page, the previous page, the next page, or the last page in a document.

The last set of icons—five sea-green squares with white v's in the center—are the Jumpmark keys. A Jumpmark allows you to jump around from point to point or paragraph to paragraph in a document instead of scrolling.

If you like the clean look, click on the white box on the right hand side above the vertical scroll bar to make the toolbar disappear.

A helpful feature for the oh-so-organized among us can be found in the Windows menu. If you're like me and tend to work on several documents at once, you can choose to Tile or Stack the windows in a neat and orderly manner.

1. <http://hotfiles.zdnet.com/cgi-bin/texis/swlib/hotfiles/info.html?code=MC19111&b=mac>

Is it Worth it?

Obviously not, if you have Microsoft Word. But I know someone (new to the Mac) who says icWord does all she needs it to do: open Word documents that come attached to e-mail messages.

icWord seems to be a practical and user-friendly program for those Mac users who don't have Word and need to read Word documents. The simple toolbar layout is easy to navigate without the help of the documentation. The Tile and

Stack Windows options are very useful, and the overall look of the program (especially the toolbar) is clean and tasteful.

However, there are some bugs. Not every document opens in its original form, as noted with the columns and pictures examples. Perhaps more important (as we're dealing mainly with text here), RTF files don't seem to translate in icWord. But I still think icWord is worth a look, or at least a free 30-day download.

Copyright © 2000 Brooke Smith, bsmith@atpm.com. Reviewing in ATPM is open to anyone. If you're interested, write to us at reviews@atpm.com.



Review: Kyma 5.0

by David Ozab, dozab@atpm.com

Developer: Symbolic Sound, Inc.

Web: <http://www.SymbolicSound.com>

Price: \$3300 with base Capybara 320 hardware system (upgrades extra).

Requirements: Power Mac with PCI or PowerBook with PCMCIA, or '040 Mac with NuBus.



As anyone who's had the opportunity will tell you, beta testing a great piece of software is a rewarding experience. I, along with my colleagues at Future Music Oregon, recently had this opportunity with the beta versions of Kyma 5.0. I had already worked with Kyma for a few years on and off, and, when I saw what was coming in this new version—the Sound Browser, the redesigned Virtual Control Surface, and especially the brand new Time Line—I knew that it represented a major breakthrough in ease of use.

There were bugs of course, as there always are in beta software, but Carla Scaletti and Kurt Hebel (co-founders of Symbolic Sound) maintain a close relationship with the individuals and institutions that use Kyma systems, and they listen closely to feedback. They were also wise not to rush out a complete version. Instead they took their time, and, as far as I can tell, caught all the bugs. As a result of their efforts (and much feedback from regular customers like us), Kyma 5.0 is an exceptional piece of software.

Kyma is, for the uninitiated, a software interface for the Capybara 320, a black box, multiprocessing, synthesis, and sample processing monster. The Capybara represents both the power and the flexibility of the system, combining an open architecture with pure number crunching muscle. Kyma is the interface and the organizer, telling the Capybara what it is to be (FM synthesizer, granular sample processor, reverb chamber, etc.) and allowing the user to control the resulting “instrument.” With each version, the people at Symbolic Sound have made the impressive power of the Capybara easier to use. Kyma 5.0 is not an incremental improvement in this area, though; it is a genuine breakthrough.

The Sound Browser

The Sound Browser is a great place to start for both newbies and veterans. An improvement upon the File Organizer, the Sound Browser adds auditioning capabilities, allowing you to preview the Sound before opening it. You can also direct either audio inputs or other Sounds directly into the Sound Browser, which is an easy way to test different processes before you begin editing the Sounds directly. With its extensive categorical organization, the Sound Browser is a powerful alternative to the venerable Prototypes window. My only qualm (file this under the category “room for improvement”) is the use of fairly vague colors and icons. I personally

have trouble seeing the gray text of unselected items, and still have no idea which specific files types correspond with the different colored boxes across the top of the Sound Browser. My recommendations for a future version include clearer icons for file types, and a graphic style closer to the Mac interface, with folder and file icons.

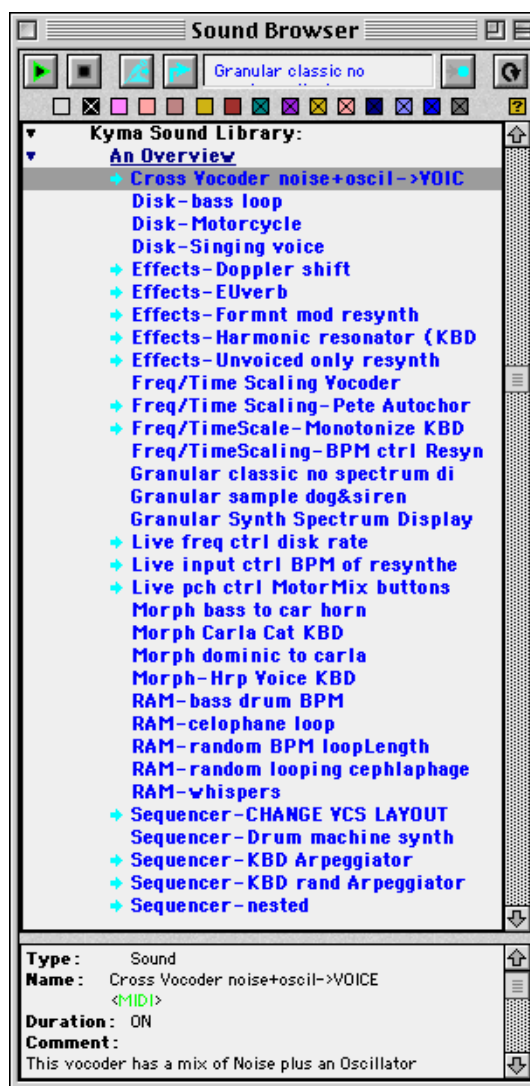

Speaking of Prototypes

Kyma 5.0 boasts new categories in the Prototypes window, which group Prototypes by function. The complete list is as follows: spectral processing, vocoders, sample processing, additive synthesis, synthesis, sequencers, pitch/formant shifters, effects, envelopes, and miscellaneous. A number of new Prototypes have been added, while one, Concatenation (which strings Sounds in a sequence), has been retired. In general, the Time Line window (discussed below) takes over the function of the mixers. For old patches with Concatenation, an Overlapping Mixer with an overlap time of zero will be substituted. As a whole, the organization is clearer, and the Prototypes themselves are more complex and therefore can act as “presets” for a new user.

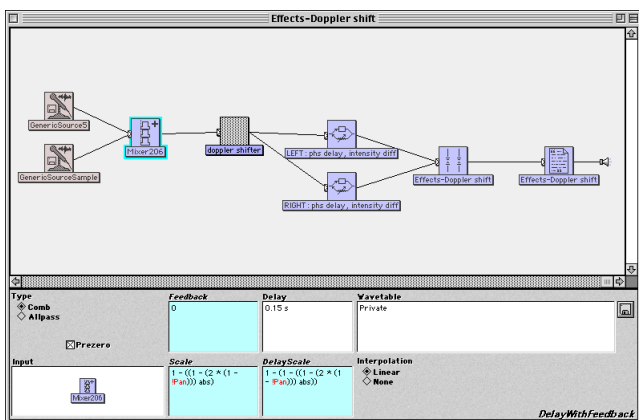

And the Sounds Themselves

At the core of Kyma are the Sounds. These self-contained modules are usually constructed out of other simpler Sounds. As with previous versions, clicking on an input shows the source of that input to the left, and double-clicking on a Sound opens its parameters. Version 5.0 adds color coding—red for source, blue for modulator, yellow for control, and black for algorithmic sources. Most significantly, it eliminates the duration field. Instead of having to set the duration of each Sound individually, you either add a Set Duration prototype to the end of the chain or modify the length in the Time Line. Either approach is a great improvement, and, after the Time Line itself, this is my favorite improvement in Kyma 5.0. I think back to all the times I had to click open ten or fifteen modules in a complex Sound just to reset its duration. What a hassle! Now the duration is in one place and one place only. Hooray!

Which Brings Me to the Time Line

Take away all the other improvements in Kyma 5.0, and it would still earn an Excellent rating by virtue of the Time Line window alone. This is the interface component I've been waiting for. In the past, one had mixers and Concatenation, but keeping track of when every event was happening was almost impossible. I quickly hit a wall with Kyma 4.5. I was

generating impressive dynamic Sounds, but needed other, clearer methods (Pro Tools or Studio Vision) to bring them together in a complete piece. (This is, in fact, how I realized *Equinox*, my first composition involving Kyma.) When I first saw the time line in a beta version of Kyma 5.0, my immediate reaction was “of course, this is exactly what I've wanted all along.”

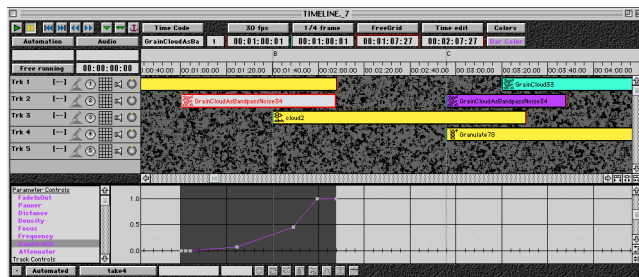

My experience in computer music is based first and foremost in sequencers and hard disk recorders, both of which use a similar approach to representing events (either MIDI or audio) over time. In adopting a similar method to depict Sounds (which incorporate MIDI, audio, and just about every other process Kyma is capable of realizing), Kyma 5.0 gives its users the ability to easily control the flow of events over time.

Interacting with the Time Line window is easy. Sounds can be dragged either from a Sound File window or directly from the Prototypes window, placed at any point, and stretched to any length. Multiple Sounds can be layered on separate tracks, which can be muted or soloed, as in any hard disk recorder. The tracks can also accept audio input and MIDI control, and they can be routed to any of the Capybara's four (expandable to eight) outputs.

Select a Sound, and you can alter every parameter available within it. This includes both universal settings, like FadeInOut, Panner, and Distance; and hot fields (i.e. parameters set to receive control input) set within the individual Sound. Four edit points are provided, but many more can be added simply by option-clicking or control-clicking. You can also open and edit Sounds in the Time Line window just as you can in the Sound File window. Overall, the Time Line window makes controlling both Sounds and their parameters over time much easier than before. Thanks to all these new features, I was able to realize the entire electronic part of a composition for double bass and electronics (*Cirrus...Cumulus...Nimbus*) while beta testing Kyma 5.0. A portion of the time line for this work provides the above example.

While on the Subject of Control

The venerable Virtual Control Surface is back and better than ever. It sports a new look, which, though still not particularly Mac-like, is an improvement. And it gives one a great deal of

editing power through the Graphic Editor window. Widget type, placement, MIDI mapping, and numeric range (not just 0 to 1 or -1 to 1 anymore) are all editable, and multi-level surfaces can be designed, which helps separate parameters by their component Sound. Adding the Spectrum Analyzer and/or the Oscilloscope Display to the end of the signal path adds real-time visual display to the Virtual Control Surface (see example below, which includes the Oscilloscope Display). This is a great addition, particularly as a teaching tool. Multiple sets of fader settings can be saved as presets, and values can be reassigned randomly or locked to prevent their reassignment. This is a wonderful way to find new Sounds. Just lock the parameters you want to keep and vary the others, locking as you go perhaps and narrowing in on that “perfect” setting that you may have never found otherwise.

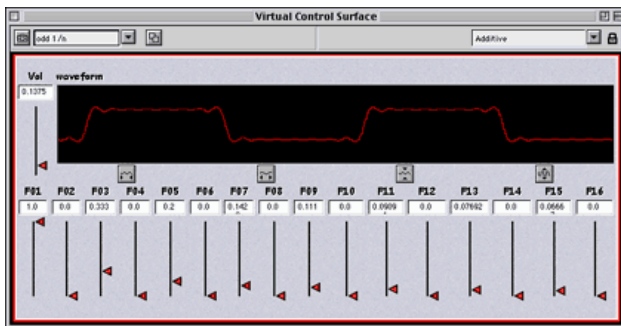

What About the Price?

Yes, Kyma 5.0 is expensive (unless you are upgrading and already own a Capybara 320, in which case I say “Get it *right now!*”), and it is not for everyone. If you’re on a tight budget, there are software-only platforms (Metasynth and MAX/MSP jump to mind) that provide a good open-ended sound design environment. You get what you pay for, and, for the price, Kyma 5.0 is an unbelievable bargain. For the same cost as a typical keyboard workstation you get a true black box (with a cool blue LED)—synthesis, sampling, MIDI, audio processing, algorithmic composition, and real-time interaction; it’s all there.

And with all its improvements, Kyma 5.0 finally brings the learning curve low enough for novices. The interface is much easier, without sacrificing any of the power that experienced users have come to expect. My only complaints (nothing in life is perfect after all) are minor ones involving legibility of gray text in the Sound Browser, and the generally obscure appearance of many buttons. These don’t even begin to threaten Kyma’s Excellent rating. There is nothing else that compares to it, for the price it’s an incredible bargain, and, most importantly, the interface is much clearer than ever. Kudos to Symbolic Sound. You have truly outdone yourselves.

Copyright © 2000 David Ozab, dozab@atpm.com. [David Ozab](#)¹ is a Ph.D student at the University of Oregon, where he teaches electronic music courses and assists in the day-to-day operation of The Future Music Oregon Studios.



1. <http://darkwing.uoregon.edu/%7Edlo>

Review: Nomad II 32 MB

by Eric Blair, eblair@atpm.com

Developer: Creative

Web: <http://www.nomadworld.com/products/nomad2/>

Price: \$219.99

Requirements: G3-based Mac or higher, USB port, Internet connection



It's long been said that a technology is not truly useful until its third generation sees the light of day. If that adage is to be believed, now is the time to jump on the portable MP3 player bandwagon. For a more in-depth description of these devices, take a look at Daniel Chvatik's [review of the Diamond Rio 500](#)¹.

The first generation of portable MP3 players was the original Diamond Rio. The second generation included devices like the Rio 500 and the Creative Nomad. Now, we're seeing the third generation in the form of the Rio 600, the Samsung Yepp, and the Nomad II. As the market for these devices has matured, more and more have become available for the Mac. One of the companies that has come to the Mac with a whole slew of products is the aforementioned Creative.



The Nomad II 32 MB includes the player, a pair of “behind-the-neck” headphones, a remote headphone control, one AA battery, a 32 MB SmartMedia card, a USB cable, and a carrying case. Personally, I prefer the behind-the-neck headphones to standard headphones or ear buds. You know you're not going to get top-of-the-line headphones with an MP3 player, and I find the behind-the-neck headphones more comfortable than the other two types.

I also like the remote control that attaches to the headphone cord. This lets you play, pause, stop, skip songs, and adjust the volume without unclipping the Nomad II from your belt.

Like the Rio 500, the Nomad II's carrying case is essentially useless. When I take the Nomad with me, I usually clip it to my belt. The Nomad is small enough so that it's not obtrusive—certainly nowhere near as obtrusive as the cell phone that I carry. I don't even know what I've done with the case.

According to Creative, the single AA battery will power the Nomad in MP3 or Voice mode for 8–10 hours. In using the Nomad off and on, I haven't had any difficulty with the battery.

The Display

The Nomad II uses a decent-sized LCD to provide access to most of its options. The main menu has six icons: one for each of the three sound modes, one to get info on the player, one to change the settings, and one to display the time and date. You use the large four-way pad on the center of the Nomad II to navigate the menus. Right, left, and down change the active icons, while up selects the active icon.

A battery meter is present on the LCD whenever the unit is in use. If there is a SmartMedia card installed, there is an icon for that. If the unit is locked, a lock is displayed on the screen. Finally, when listening to music, there is a volume icon on screen.

When initially selecting the music mode, you see a list of songs loaded on the memory card. Unfortunately, the Nomad II only displays the first eight characters of the file names along with the file type. If you're like me and put the name of the group at the front of the file name, you could end up with a bunch of files named “BLINK182MP3.” The Nomad II is able to interpret ID3 tags, so I don't understand why it cannot display the song or band name from this information.

1. <http://www.atpm.com/5.12/rio500.shtml>

Music to Your Ears

As I said earlier, the Nomad II 32 MB comes (obviously) with 32 MB of RAM. In terms of MP3s, that works out to about 35 minutes of audio at 128 KBps. For anybody who wants to use the Nomad II for anything more than short term listening, this really isn't acceptable. In my opinion, 64 MB is the minimum for listening to MP3s.

When you're listening to MP3s, the Nomad II features the standard set of controls. The four-way pad that controls menu access also controls music playing. Pressing Up plays or pauses playback. Pressing Down stops playback and returns you to the list of songs. Left and Right are the song/time advance buttons. Pressing and holding the buttons adjusts the time in the song. Pressing and releasing moves to the next song. You can also repeat a portion of a song, an entire song, or all the songs.

The Nomad II includes several preset DSP modes that are supposed to simulate listening environments like Jazz, Rock, or Classical. There is also a User setting where you can specify the bass and treble that you want.

Along with being able to play MP3s, the Nomad II also comes with a built-in microphone that can record voice memos. In terms of size, voice memos are a bit easier to deal with—a one MB voice file can hold about 3 minutes 45 seconds of audio, as opposed to the nearly 1:1 ratio of music to MB with MP3s.

Another feature of the Nomad II is a built-in FM tuner, complete with 32 preset channels. When the Nomad is first used, all of these channels are preset to channel 87.5. The presets can only be changed when the Nomad is connected to a computer. Like many Walkman-type devices, the headphone cord acts as an antenna. If you are listening to the Nomad II at a desk, you may be able to prop the cord up against something to improve reception. If you are moving around, however, it can be difficult to keep the signal for a radio station.

With an upgrade to the latest firmware, version 2.00.19, the Nomad II is supposed to be able to play files in the Windows Media Format. Unfortunately, Creative's software for updating firmware is Windows-only. If the firmware update only added the ability to play WMA files, it wouldn't be that big a loss. However, it also adds niceties like the ability to scan the FM frequency for a channel. Using the original firmware, I had to step through each individual frequency—87.5, 87.6, 87.7, etc.

It's quite likely that Creative will release future firmware updates that provide support for additional features—things like larger SmartMedia cards and audio formats like LiquidAudio. The Rio supports firmware updates on the Mac using SoundJam MP. I see no reason why the Nomad II should not support this.

Oh yes, back to Windows Media Files—I managed to track down some of these files at [MusicMatch](http://www.musicmatch.com/)¹ after updating my firmware on a PC. I tried loading the same file from both a

PC and a Mac and received the following message: "WMA License Does Not Match." I assume this is a copy-protection thing. Maybe if I had an unprotected WMA file, it would work, but I haven't got the slightest idea where to find such a file.

One final note about the new firmware: whenever I load songs from my Mac to my Nomad II, they initially show up in the playlist without a file name. At first, I could not figure out what was causing the problem. The Nomad II obviously knows the name of the file—if I try to delete the file or play a file without an ID3 tag, the player displays the proper name. After mentioning the problem to a friend, I was informed that the solution to this was to delete the .aux file that SoundJam MP creates when uploading songs. This file appears to contain ID3 tag information, although the Nomad II recognizes the ID3 tags in the individual songs without this file present.

The Software

The Nomad II that I received did not include the Mac drivers, although it is possible that this could have changed by the time you read this. I needed to download both the Nomad II drivers and SoundJam MP from the [Nomad II download page](#)².

In the end, you end up with three separate applications with functions that overlap. SoundJam MP is easily the best-known of the three applications. This version is a slightly modified copy of SoundJam MP Free. Aside from including the ability to recognize a Nomad II, the software's MP3 encoding ability does not disappear after 14 days. SoundJam MP provides the following for use with the Nomad: uploading and deleting music files; uploading, downloading, and deleting voice files; setting the presets for FM stations; naming your Nomad; showing how much memory is available; and playing MP3 and voice files.

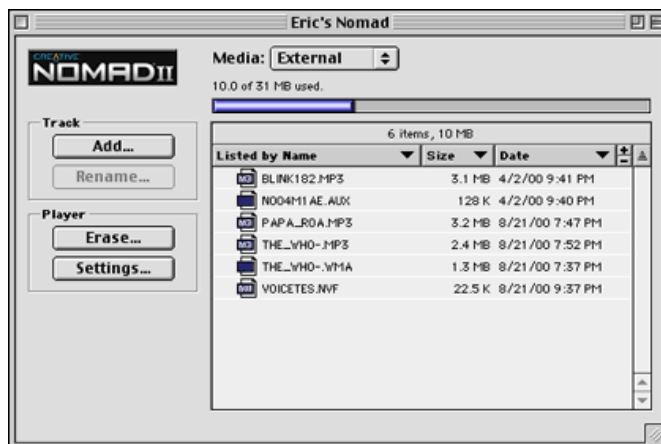

SoundJam MP's interface for the Nomad II.

1. <http://www.musicmatch.com/>
2. <http://www.nomadworld.com/support/drivers/welcome.asp?reg=0&os=mac&prod=nomad2&Select=Get+Files&x=50&y=2>

The second application is Nomad Manager. It shows you information about the player like the firmware version. It lets you upload and delete music or voice files, download all voice files, and search for MP3s to upload. At first glance, it may sound like Nomad Manager is the perfect application for you, especially if you use an MP3 player other than SoundJam MP. It's not that simple, though: when you upload a song using Nomad Manager, it doesn't retain its ID3 tag. When you play the song, all you see are the first eight characters of the file name and the 3 character DOS file name extension.

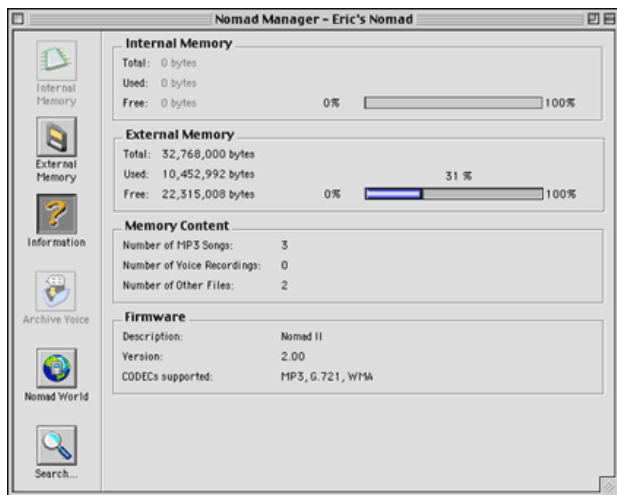

Nomad Manager's info screen for the Nomad II.

The last application is Nomad Voice File Player. Like the name suggests, this application plays voice files downloaded from the Nomad. Once again, at first glance, it seems as though the functionality of this application is completely replicated by SoundJam MP. Not so fast: along with playing the voice files, Nomad Voice File Player can convert these files to AIFF or WAV.

To get the full functionality of the Nomad II, you need all three pieces of software. It would seem like certain features could be consolidated into one or two application, especially given that the Nomad II features in SoundJam MP were added to after the initial release of the program. Personally, if SoundJam MP added an "Info" button to the Nomad II window, I would get rid of Nomad Manager in a minute.

Conclusion

The Nomad II has several features that the Rio 500 lacks—namely, an FM tuner and a voice recorder. However, the hodgepodge of software and the lack of firmware updates for the Mac, along with the small bundled memory card, make it difficult to recommend the Nomad II 32 MB. If you want an FM tuner or a voice recorder, you would be better off looking at the Nomad II 64 MB. Until Creative fixes some of the Nomad's issues with the Mac, you might want to consider a model from the Rio line of players.



Review: PGPfreeware 6.5.2 and SafeMail 2.1

by Gregory Tetrault, gtetrault@atpm.com

PGPfreeware 6.5.2

Developer: PGP Security (a Network Associates Business)

Web: <http://www.pgp.com/>

Price: free for non-commercial use, not readily available outside the USA and Canada due to encryption technology export restrictions.

Requirements: Power Mac with Mac OS 7.6.1 or later, 16 MB of RAM.



SafeMail 2.1

Developer: Highware, Inc.

Web: <http://www.highware.com>

Price: \$39 (shareware)

Requirements: Power Mac with Mac OS 7.6 or later, 2 MB of RAM.



Introduction

The US Congress recently passed legislation sanctioning the use of digital signatures for purposes such as contracts and legal documents. Essentially, a digital signature is just as valid as a written signature. Interest in digital signatures rose quickly since this legislation passed, and I began a quest for Macintosh software that would let me digitally sign my e-mail. The pickings were slim. The only two applications I found that would work with standalone e-mail applications were PGPfreeware and SafeMail. Other applications or plug-ins work with specific Web browsers to provide certification or authentication. I did not look at these applications.

E-mail digital signatures typically use the public key/private key security scheme. You create a public key for each of your e-mail accounts and upload it to one or more public key servers. The public key becomes available for anyone to access or download. A private key is created along with your public key, and you assign it a password. Your private key does not get distributed. You use your password-protected private key when you sign or encrypt (or both) your e-mail. If you send signed e-mail to someone, he can read your e-mail and verify that it truly came from you by looking up your public key. If you send encrypted e-mail to someone, she must access your public key to decrypt the message. If you encrypted and signed your e-mail, the decrypted e-mail also contains your digital signature.

Downloading and Installation

You [download](#)¹ PGPfreeware from MIT's Web site. You first answer four "yes/no" questions about your country of resi-

1. <http://web.mit.edu/network/pgp.html>

dence, expected usage, and license requirements. If you answer "yes" to all four questions, you are directed to the download page. (Note: do not bother lying about your country of origin. PGP will not download if your IP address maps to any countries other than the US or Canada.) The PGPfreeware download (poorly labeled as "Archive.sit") is 5.4 MB. The full default installation (via an Installer VISE script) requires 10 MB of disk space. Installation is simple and quick. You must restart your computer to use PGPfreeware. PGPfreeware (full installation) includes three applications (PGPtools, PGPkeys, PGPnet), seven extensions, one contextual menu item, an Apple Guide document, a 220 page-PDF manual, and an 88-page PDF guide to encryption.

You download the SafeMail shareware program from Highware's Web site. The download file is 2 MB. The full default installation requires only 2 MB of disk space. Installation (via an Installer VISE Lite script) is simple and quick. As with PGPfreeware, you must restart your computer to use SafeMail. SafeMail is compatible with PGP-based applications and can use their personal and public key files. SafeMail is comprised of the SafeMail Keyring Manager, Eudora and Sherlock plug-ins, an extension, a contextual manager file, an OpenLib Folder containing a FileCrypt application and 27 library files, and an 88-page PDF manual.

Creating Keys and Uploading Public Keys

PGPfreeware allows quick and easy creation of your private and public keys. You launch the PGPkeys application directly or from the PGP menu (a gray padlock icon, see Figure 1). You click the key icon, select New... from the Keys menu, or type Command-N to launch a "Key Generation Wizard." The

wizard walks you through the steps needed to create keys. You first enter your name and e-mail address. You then choose the type of key pair: the newer Diffie-Hellman/DSS or the older RSA.



Figure 1: Padlock Menus for PGPfreeware (grey) and SafeMail (gold)

You then select the key size (from 1024 to 4096 bits). Larger key sizes are more secure but are slower to use. Next you decide when your key should expire. (The default choice is never.) PGPkeys' wizard then asks you to enter and confirm a passphrase containing at least eight characters. PGPfreeware recommends mixing alphabetic and non-alphabetic characters. A bar graph rates the quality of your passphrase (mixing upper and lower case and intermingling numbers and other characters increases the quality). The wizard has two passphrase security features: you can choose to hide typing while entering the passphrase and you must retype the passphrase in the confirmation box (you cannot use copy and paste).

When your passphrase is confirmed, you have the option of sending your public key to Internet servers. PGPfreeware lists two public key sites: ldap://certserver.pgp.com and <http://pgpkeys.mit.edu:11371>. You can manually send your public key to your domain server or to any other public key site. (You can also use preferences to add other key server choices.) Your key now appears in the PGPkeys window (Figure 2). Overall, key generation with PGPfreeware was quick and easy.

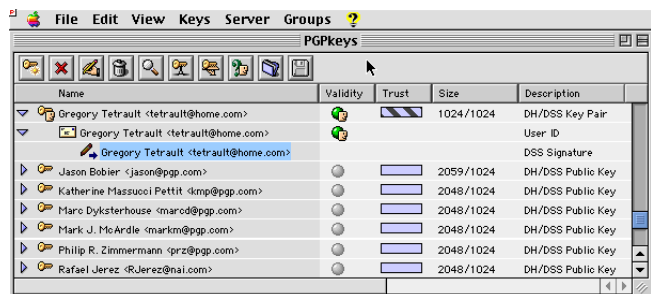

Figure 2: The PGPkeys Window

SafeMail also allows quick and easy key creation. You launch the SafeMail application directly or by choosing Keyrings... from the SafeMail menu (a gold padlock icon, see Figure 1). Selecting New Key Pair... from the Keyring menu launches (guess what) a Key Generation wizard. You enter your name and e-mail address in the first window. You choose the key pair type (DSS or RSA) and key size (768, 1024, 1536, 2048, 3072, or 4096) from a pop-up menu. You then choose Never or a specified number of days (not a date) before the key expires. SafeMail gives you the option of adding your Web site URL and other information to your public key. (Users access this by choosing Get Info on your key.)

Next comes the passphrase window. You have no options here; you must blindly type your passphrase twice. If your typing was error-free, the Create Key button becomes clickable. Key creation time was much longer than with PGPfreeware even with the same key type and size. When your key is created, SafeMail asks whether you wish to make the new key your default. The new key appears in SafeMail's PGP Public Keys/PGP Private Keys window (Figure 3). To upload your key you choose Send Selection from the Server menu. SafeMail sends your key to www.keyserver.net:11371 unless you type a different key server URL into the dialog box. Overall, key generation was a bit slower and slightly more complicated than with PGPfreeware.

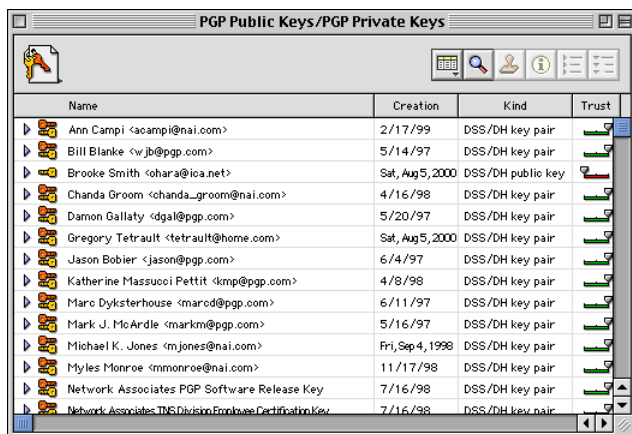

Figure 3: SafeMail's PGP Public Keys/PGP Private Keys Window

Signing and Encrypting Email

Both programs use nearly identical techniques for signing or encrypting e-mail. In your e-mail program you select the portion of the e-mail you wish to encrypt (none, any, or all). You then access the padlock menu and choose your option (sign, encrypt, or both). If you just want to sign your e-mail, both programs display a small dialog box for entering your passphrase.

If you choose Encrypt (or Encrypt and Sign), you must then select a recipient's public key. If your recipient is already known, both programs display a recipient list window (Figures 4 and 5). You choose one or more recipients. If your e-mail recipient is not listed in your public key files, you have to add the recipient.

PGPfreeware connects to certserver.pgp.com and accesses your list of recipients. This wastes time because the recipient's key will not be listed. You must cancel this operation, launch PGPkeys, and choose Search... from the Server menu (or type Command-F). When you find the public key for your recipient, you drag it to your PGPkeys window. You then return to your e-mail program and choose Encrypt again. SafeMail also requires you to find the unknown public key by selecting Find Keys... from the Edit menu. You choose which key server to search, then enter the search information. Select

the public key from the list, then click the Import button to add the public key to your keyring.

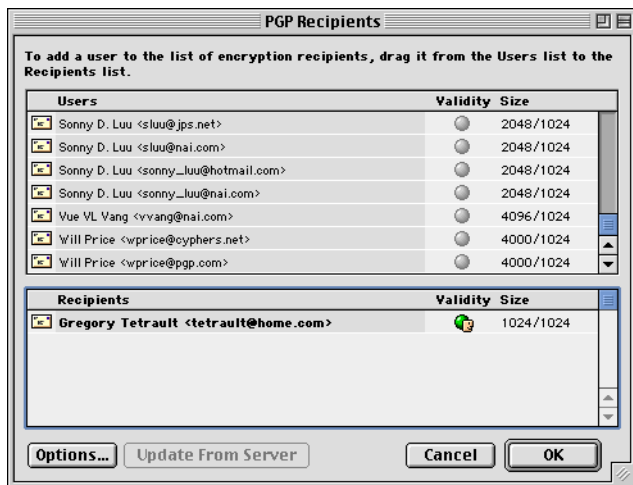

Figure 4: PGP's Recipients Window

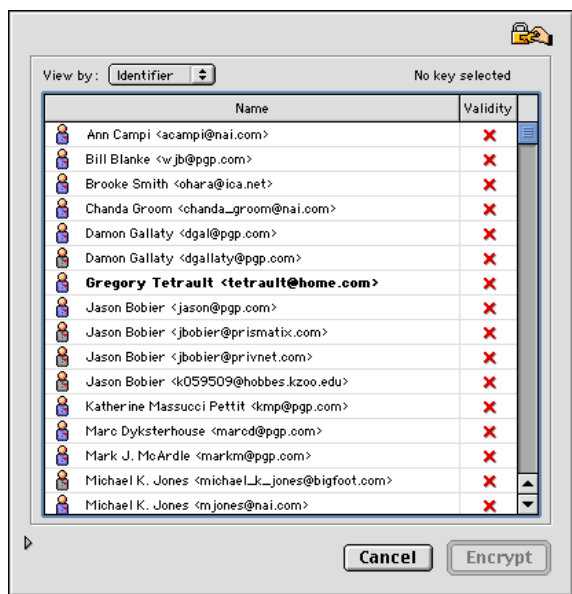

Figure 5: SafeMail's Recipients Window

Verifying and Decrypting Email

Both programs verify signed e-mail by accessing the appropriate public key (attached to the e-mail, listed among your recipients, or located on a public key server). PGPfreeware silently accesses the public key and then adds information to your e-mail text about the identity of the signer. SafeMail displays a Signature Check dialog box listing the signer's identity and key validity. SafeMail also adds information to your e-mail text. You can remove the added information by clicking the Restore Original button at the bottom of the Signature Check dialog box.

You decrypt e-mail in both programs by selecting the encrypted text (with SafeMail you only need to place your cursor within a block of encrypted text), choosing decrypt from the padlock menu, and entering your passphrase in a dialog box. Both programs rapidly decrypted text.

Stability

I used PGPfreeware for over three weeks with no problems or crashes. SafeMail frequently caused Outlook Express 5.02 to crash with type 2 or 3 errors. I also experienced three complete system crashes in less than two hours after installing SafeMail. The crashes continued even after I removed PGPfreeware from my Macintosh. SafeMail also pops up pay the shareware fee reminder screens each time you launch and whenever you try to decrypt or look up public keys.

Recommendations

I highly recommend PGPfreeware. It handles all your e-mail signature and encryption needs and costs nothing but download time. Its manuals and help files are excellent. PGPfreeware includes PGPnet, an application that allows you to create a virtual private network over the Internet using an encrypted tunnel. PGPfreeware also can completely wipe (beyond the ability of anyone to recover or read) individual files or all the free space on a drive.

SafeMail also handles all your e-mail signature and encryption needs. Some tasks are easier to perform with SafeMail than with PGPfreeware. However, SafeMail causes many application and system crashes and costs \$39. Stay away from this program unless you live outside the US or Canada and cannot download PGPfreeware.

Copyright © 2000 Gregory Tetrault, gtetrault@atpm.com. Reviewing in ATPM is open to anyone. If you're interested, write to us at reviews@atpm.com.



Preview: Kodak Smart Picture Frame

by Daniel Chvatik, dchvatik@atpm.com

Preview

Developer: Weave Innovations

Web: <http://www.storybox.com>

Price: \$349 (includes six months of premium service)

Requirements: Mac with Internet connection, Netscape 4 or later or Internet Explorer 5 or later.

Computer technology keeps creeping into our lives. Computers used to be simply tools for work, and many people were happy to enter a computer-free environment after the work was done. Staring at a flickering screen for several hours a day is quite enough for them. But as speed, bandwidth, and memory capacity keep increasing, computers and the associated technologies are no longer restricted to the workplace. The emergence of [MP3s](#)¹ is one example. Although the MP3 standard started more or less as a pure computer-side compression scheme, MP3 players are now a common item outside of the office. Similarly, Apple's [iMovie](#)² takes an activity that was previously separated from the digital world entirely, and literally brings it to your desktop.

Pictures were similarly "digitized." And while digital cameras used to be a geek toy or restricted to professional use, they are quickly becoming an everyday item. For some people, they have entirely displaced traditional film cameras. But such computerization has its growing pains. Like MP3s, which in the beginning were not good for much else but listening on mediocre computer speakers, digital pictures were mostly restricted to the digital canvas on your computer screen. Yet, as often happens when such "advances" hit mainstream computing, people miss some features of the "traditional" technology—in this case of the simple feel of a photograph. A digital picture is nice, but it just doesn't have the texture of a freshly developed piece of photographic paper, nor its gloss. You can't put a digital picture into a "real" photo album or give it centerpiece status in a picture frame. And you can't really show it to your computer-less grandparents unless you carry your laptop with you to the next family reunion.

Improvements in printer technology, which now give us a wide choice of photo-quality printers, have removed some of those drawbacks, but at the cost of the convenience and speed that are at the core of digital pictures. What good are digital pictures if you have to print all of them out again, converting them back to the analog format that we tried to avoid in the first place?

...

1. <http://www.atpm.com/6.03/mp3players.shtml>

2. <http://www.atpm.com/6.06/imovie.shtml>

Weave Innovations' Kodak Smart Picture Frame and StoryBox Network picture exchange service attack just this issue. By combining the more traditional feel of a (digital) picture frame with the vast modern information handling capacities of the Internet, their product promises to combine the best of both worlds on its 6.4 inch color LCD. Weave Innovations was kind enough to provide ATPM with some pre-production units for preview purposes. The units gave us a glimpse at the future of digital imaging. However, some technical glitches in the beta units prevented us from taking them through a full review. Instead, we will share our thoughts with you now, and hopefully follow up with a full review of the customer units in our next issue.



You may already have seen digital photo frames in stores by now. [Sony's play on the theme](#)³ is modern and high-tech looking. Weave Innovations decided on a more traditional, wooden look. While Sony's picture frame accepts only their proprietary memory stick, the Kodak Smart Picture Frame—which will be distributed by Kodak later this year—accepts both CompactFlash cards and an "online" connection through your familiar phone line. The phone line serves as the primary means of connecting the outside world to your picture frame. When you setup the frame, you have to register at the StoryBox Network Web site. The frame dials a

3. http://64.14.40.97/product_info/html/product_PHDA55.html

free 800 number, confirms it is properly registered, and then finds the best local phone number for future connections. Through the Web site, you can upload your own pictures to the frame; send and receive greeting cards; share pictures with others; and even set news, weather, sports and similar “channel” content to be loaded into your frame.



The Web site lets you set up a contact database and allow others (like your kids, your parents, or your significant other on the road) to send their pictures directly to your frame. Imagine the glow on mom’s face if her kid in college sends a weekly picture to her frame. Certainly, you could simply e-mail the images, but it’s less personal and not everyone has e-mail access. In this way, a frame may be a wonderful gift for a technologically challenged family member (just make sure you set it up for him), but even hard-core technophiles may enjoy this little gadget. I, personally, spend a lot of time—professionally and personally—on the Net, but I

would appreciate it if I could shift some of that use away from the computer, because I can’t even recall the last time I sat down in my living room. The addition of informational content channels allows you to take a break from the screen and get your dose of information overload in a different way.

The frame itself can rotate images, and you can share pictures among several frames. Instead of showing a single static picture, you can have all of the images displayed in a slide show fashion. Who knows, maybe future versions will even support simple movie-playback, allowing your friends and relatives to send over a little iMovie of the last vacation!

Not everything is rosy though. Support for the less technical among us may leave power users without the tweaks they want. I wish the frame could bypass my slow phone line and get its content through my DSL connection via the Ethernet LAN. Of course, I am part of a small, but growing minority with faster network connections. Alternatively, a direct USB connection to the frame to upload pictures would be nice. In any case, you can forget about watching movies in future frames if the bandwidth issue isn’t addressed. Also, to use the frame efficiently with Web sharing and channels, you are required to buy a subscription, starting at \$4.95, and ramping steeply upwards depending on how many channels and updates per month you want to purchase. At least those with cravings for real paper can have the photos printed and sent home by Kodak.

•••

Like MP3 players, digital picture distribution via more traditional means will become more common in the next years. Besides simply presenting the images, they will make sharing of images and information easier than ever. I can’t wait to see more of the future.

Copyright © 2000 Daniel Chvatik, dchvatik@atpm.com. Reviewing in ATPM is open to anyone. If you’re interested, write to us at reviews@atpm.com.



FAQ: Frequently Asked Questions

What Is ATPM?

About This Particular Macintosh (ATPM) is, among other things, a monthly Internet magazine or “e-zine.” ATPM was created to celebrate the personal computing experience. For us this means the most personal of all personal computers—the Apple Macintosh. About This Particular Macintosh is intended to be about your Macintosh, our Macintoshes, and the creative, personal ideas and experiences of everyone who uses a Mac. We hope that we will continue to be faithful to our mission.

Are You Looking for New Staff Members?

We currently need several [Contributing Editors](#), an [Interviews Manager](#), a [Copy Editor](#), and a [Publicity Manager](#). Please [contact us](#)¹ if you're interested.

How Can I Subscribe to ATPM?

Visit the [subscriptions page](#)² or send an e-mail to subscriptions@atpm.com with the word help in the subject line. Instructions for subscribing and unsubscribing will be returned, shortly.

Which Format Is Best for Me?



The [Online Webzine](#) edition is for people who want to view ATPM in their Web browser, while connected to the Internet. It provides sharp text, lots of navigation options, and live links to ATPM back issues and other Web pages. You can use Sherlock to [search](#)³ all of the online issues at once.



The [Offline Webzine](#) is a HTML version of ATPM that is formatted for viewing offline and made available in a Stuffit archive to reduce file size. The graphics, content, and navigation elements are the same as with the Online Webzine, but you can view it without being connected to the Internet. It requires a Web browser.



The [Print PDF](#) edition is saved in Adobe Acrobat format. It has a two-column layout with smaller text and higher-resolution graphics that are optimized for printing. It may be viewed online in a browser, or downloaded and viewed in Adobe's free Acrobat Reader on Macintosh or Windows. PDFs may be magnified to any size and searched with ease.



The [Screen PDF](#) edition is also saved in Adobe Acrobat format. It's a one-column layout with larger text that's optimized for reading on-screen. It may

be viewed online in a browser, or downloaded and viewed in Adobe's free Acrobat Reader on Macintosh or Windows. PDFs may be magnified to any size and searched with ease.

What Are Some Tips for Viewing PDFs?

- You can [download](#)⁴ Adobe Acrobat Reader for free. If you have a Power Macintosh, Acrobat Reader 4 has better quality and performance. ATPM is also compatible with Acrobat Reader 3, for those with 680x0 Macs.
- You can zoom the PDF to full window width and scroll through articles simply by single-clicking anywhere in the article text (except underlined links).
- You can quickly navigate between articles using the bookmarks pane at the left of the main viewing window.
- For best results on small screens, be sure to hide the bookmarks pane; that way you'll be able to see the entire page width at 100%.
- Try turning Font Smoothing on and off in Acrobat Reader's preferences to see which setting you prefer.
- All blue-underlined links are clickable. Links to external Web sites are reproduced in footnotes at the bottoms of pages, in case you are reading from a printed copy.
- You can hold down option while hovering over a link to see where it will lead.
- For best results, turn off Acrobat's “Fit to Page” option before printing.

Why Are Some Links Double-Underlined?

In the PDF editions of ATPM, links that are double-underlined lead to other pages in the same PDF. Links that are single-underlined will open in your Web browser.

What If I Get Errors Decoding ATPM?

ATPM and MacFixIt readers have reported problems decoding MacBinary files using early versions of Stuffit Expander 5.x. If you encounter problems decoding ATPM, we recommend upgrading to [Stuffit Expander 5.1.4 or later](#)⁵.

How Can I Submit Cover Art?

We enjoy the opportunity to display new, original cover art every month. We're also very proud of the people who have

1. editor@atpm.com
2. <http://www.atpm.com/subscribe>
3. <http://www.atpm.com/search>

4. <http://www.adobe.com/prodindex/acrobat/readstep.html>
5. <http://www.aladdinsys.com/expander/index.html>

come forward to offer us cover art for each issue. If you're a Macintosh artist and interested in preparing a cover for ATPM, please e-mail us. The way the process works is pretty simple. As soon as we have a topic or theme for the upcoming issue we let you know about it. Then, it's up to you. We do not pay for cover art but we are an international publication with a broad readership and we give appropriate credit alongside your work. There's space for an e-mail address and a Web page URL, too. Write to editor@atpm.com for more information.

How Can I Send a Letter to the Editor?

Got a comment about an article that you read in ATPM? Is there something you'd like us to write about in a future issue? We'd love to hear from you. Send your e-mail to editor@atpm.com. We often publish the e-mail that comes our way.

Do You Answer Technical Support Questions?

Of course. Email our Help Department at help@atpm.com.

How Can I Contribute to ATPM?

There are several sections of ATPM to which readers frequently contribute:

Segments: Slices from the Macintosh Life

This is one of our most successful spaces and one of our favorite places. We think of it as kind of the ATPM "guest room." This is where we will publish that sentimental Macintosh story that you promised yourself you would one day write. It's that special place in ATPM that's specifically designated for your stories. We'd really like to hear from you. Several Segments contributors have gone on to become ATPM columnists. Send your stuff to editor@atpm.com.

Hardware and Software Reviews

ATPM publishes hardware and software reviews. However, we do things in a rather unique way. Techno-jargon can be useful to engineers but is not always a help to most Mac users. We like reviews that inform our readers about how a particular piece of hardware or software will help their Macintosh lives. We want them to know what works, how it may help them in their work, and how enthusiastic they are about recommending it to others. If you have a new piece of hardware or software that you'd like to review, contact our reviews editor at reviews@atpm.com for more information.

Shareware Reviews

Most of us have been there; we find that special piece of shareware that significantly improves the quality our

Macintosh life and we wonder why the entire world hasn't heard about it. Now here's the chance to tell them! Simply let us know by writing up a short review for our shareware section. Send your reviews to reviews@atpm.com.

Which Products Have You Reviewed?

Check our [reviews index](#)¹ for the complete list.

What is Your Rating Scale?

ATPM uses the following ratings (in order from best to worst): Excellent, Very Nice, Good, Okay, Rotten.

Will You Review My Product?

If you or your company has a product that you'd like to see reviewed, send a copy our way. We're always looking for interesting pieces of software to try out. Contact reviews@atpm.com for shipping information.

Can I Sponsor ATPM?

About This Particular Macintosh is free, and we intend to keep it this way. Our editors and staff are volunteers with "real" jobs who believe in the Macintosh way of computing. We don't make a profit, nor do we plan to. As such, we rely on advertisers to help us pay for our Web site and other expenses. Please consider supporting ATPM by advertising in our issues and on our web site. Contact advertise@atpm.com for more information.

Where Can I Find Back Issues of ATPM?

[Back issues](#)² of ATPM, dating since April 1995, are available in DOCMaker stand-alone format. In addition, all issues since ATPM 2.05 (May 1996) are available in HTML format. You can [search](#)³ all of our back issues.

What If My Question Isn't Answered Above?

We hope by now that you've found what you're looking for (We can't imagine there's something else about ATPM that you'd like to know.). But just in case you've read this far (We appreciate your tenacity.) and still haven't found that little piece of information about ATPM that you came here to find, please feel free to e-mail us at (You guessed it.) editor@atpm.com.



1. <http://www.atpm.com/reviews>
2. <http://www.atpm.com/Back/>
3. <http://www.atpm.com/search>

Trivia Challenge

by Edward Goss, egoss@atpm.com

Crack The Code

This is the latest in ATPM's series of *Trivia Challenges*. Answers to this month's *Trivia Challenge* will be found in the next issue of ATPM. If you have any suggestions for future *Trivia Challenges* or would like to contribute a *Trivia Challenge*, please e-mail me at egoss@atpm.com.

I'd like to congratulate last month's *Trivia Challenge* winners: Charlie Campo, from the great state of Maine, and Michael Josephy from Costa Rica. This month's prize of a dynamite ATPM T-shirt goes to the first two correct entries I receive at egoss@atpm.com. Individual readers are eligible to win only once every twelve months.

This month's *Trivia Challenge* is a match-the-code-name game. On the left are names of Apple PowerBook models, and on the right are their development code names. So put on your Commander Cody Secret Decoder Ring as you take part in:

Trivia Challenge 6.09—Crack The Code

1. Hooper	A. PowerBook 100
2. Mighty Cat	B. PowerBook 165c
3. Wallstreet	C. PowerBook 170
4. Lombard	D. PowerBook 190
5. Omega	E. PowerBook 540
6. P1	F. PowerBook 1400
7. Rosebud	G. PowerBook 2400c/240
8. Monet	H. PowerBook 3400
9. Blackbird	I. PowerBook G3/233
10. Epic	J. PowerBook G3/333 "Bronze"
11. Road Warrior	K. PowerBook G3 400/FireWire
12. Pismo	L. iBook

The Rules

Each question has only one correct answer. The answers are stored in a hermetically sealed envelope guarded by a crafty Siamese cat named "Chewie" who lives in our house.

Copyright © 2000 Edward Goss, egoss@atpm.com.

This Month's CD Recommendation

"[Here's To Ben](#)¹" by Jacintha. Hats off to fellow ATPM staffer Evan Trent for alerting me to this interesting set of Jazz and Pop standards by Singaporean Jacintha. Supposedly a tribute to the legendary Ben Webster's vocal style, it sounds more to me like a set of familiar songs that Jacintha can sing comfortably, allowing her liquid voice and phrasing to get the message across. No matter the inspiration, the result is an album sure to please, whether you need inspiration or you're just mellowing out. Highly recommended!

Last Month's Answers—6.08—Sibling Search

1. James Taylor	D. Livingston
2. Duane Allman	L. Greg
3. Wilbur Wright	E. Orville
4. Don Everly	I. Phil
5. Johnny Winter	N. Edgar
6. Rusty Wallace	J. Kenny
7. Jimmy Carter	H. Billy
8. Michael Schumacher	A. Ralf
9. Branford Marsalis	O. Wynton
10. Brian Wilson	C. Carl
11. Jeff Bridges	B. Beau
12. Satchel Paige	M. Virgil
13. Joe diMaggio	G. Dom
14. Doug Flutie	K. Darren
15. Dizzy Dean	F. Paul

1. <http://www.amazon.com/exec/obidos/ASIN/B000001Z62/aboutthisparticu>

