



KINDERKRAFT

®

It's Part of Growing Up.

CRIB

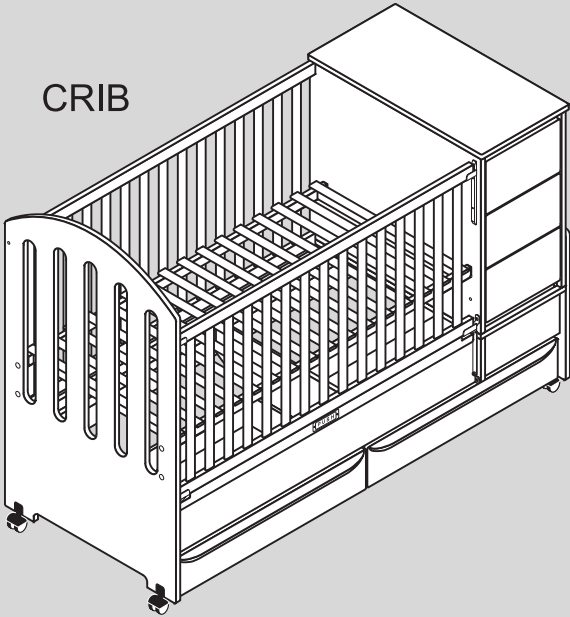

YOUTH

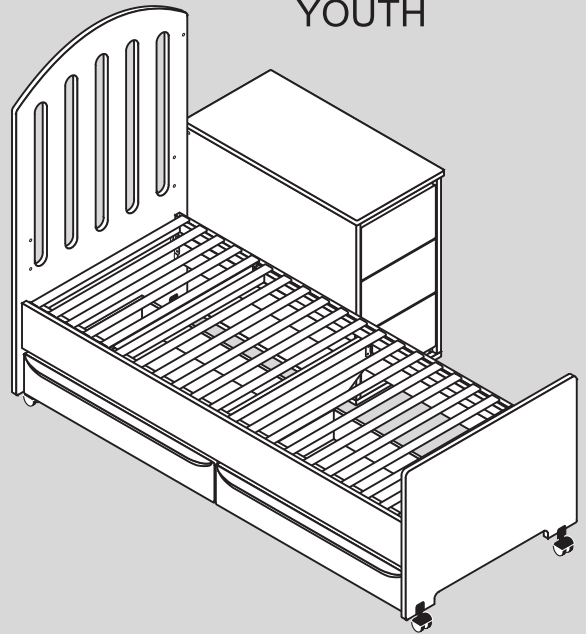

TODDLER

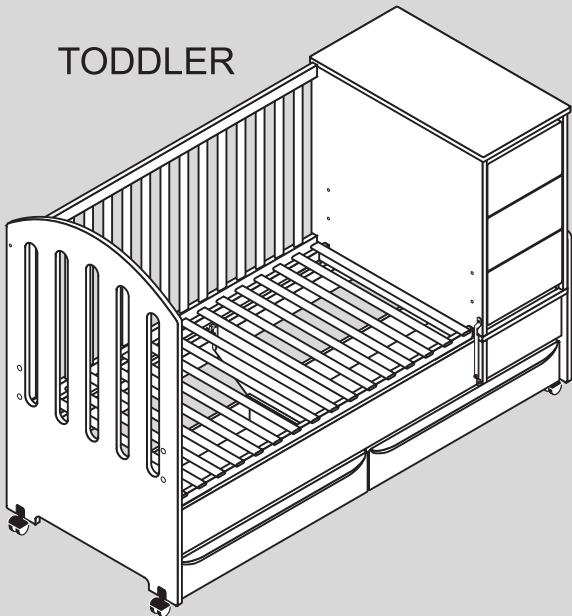

OWNERS MANUAL

CRIB 'N JUNIOR

No 5103



THANK YOU! FOR PURCHASING THIS HIGH QUALITY KINDERKRAFT PRODUCT. IF YOU NEED ANY FURTHER INFORMATION REGARDING OUR PRODUCTS, PLEASE CONTACT KINDERKRAFT OR YOUR KINDERKRAFT RETAILER. **MISSING SOMETHING? PLEASE CALL OUR CUSTOMER SERVICE DEPARTMENT FIRST AT: 1-800-822-6748.** PARTS CAN USUALLY BE SHIPPED WITHIN 24 HOURS OF ORDER.

 **WARNING:** FAILURE TO FOLLOW THESE WARNINGS AND ASSEMBLY INSTRUCTIONS COULD RESULT IN SERIOUS INJURY OR DEATH FROM ENTRAPMENT OR STRANGULATION.

 **WARNING:** STRINGS CAN CAUSE STRANGULATION! DO NOT PLACE ITEMS WITH A STRING AROUND A CHILD'S NECK, SUCH AS HOOD STRINGS OR PACIFIER CORDS. **DO NOT** SUSPEND STRINGS OVER A CRIB OR ATTACH STRINGS TO TOYS.

- READ ALL INSTRUCTIONS BEFORE ASSEMBLY CRIB. KEEP INSTRUCTIONS FOR FUTURE USE.
- BEFORE EACH USAGE OR ASSEMBLY, INSPECT CRIB FOR DAMAGED HARDWARE , LOOSE JOINTS, MISSING PARTS OR SHARP EDGES. **DO NOT** USE CRIB IF ANY PARTS ARE MISSING OR BROKEN. ASK YOUR DEALER OR KINDERKRAFT FOR REPLACEMENT PARTS AND INSTRUCTIONAL LITERATURE IF NEEDED. **DO NOT** SUBSTITUTE PARTS.
- AFTER RAISING SIDE, MAKE SURE LATCHES ARE SECURE.
- WHEN CHILD IS ABLE TO CLIMB OUT OR REACHES THE HEIGHT OF 35 INCHES (90 cm), THE CRIB SHALL NO LONGER BE USED. AT THIS POINT, CONVERT THE CRIB TO TODDLER BED OR THE CHILD SHOULD BE PLACED IN A YOUTH OR REGULAR BED.
- **DO NOT** PLACE CRIB NEAR WINDOW WHERE CORDS FROM BLINDS OR DRAPES MAY STRANGLE A CHILD.
- IF REFINISHING, USE A NON-TOXIC FINISH SPECIFIED FOR CHILDREN 'S PRODUCTS.
- **DO NOT** LEAVE CHILD IN CRIB WITH SIDE LOWERED. BE SURE SIDE IN IS IN RAISED AND LOCKED POSITION WHENEVER CHILD IS IN CRIB.
- WHEN CHILD IS ABLE TO PULL A STANDING POSITION, SET MATTRESS TO LOWEST POSITION AND REMOVE BUMPER PADS, LARGE TOYS AND OTHER OBJETS THAT COULD SERVE AS STEPS FOR CLIMBING OUT.
- NEVER USE PLASTIC SHIPPING BAGS OR OTHER PLASTIC FILM AS MATTRESS COVERS BECAUSE THEY CAN CAUSE SUFFOCATION.
- **DO NOT** TIE PACIFIERS, NECKLACES, OR ANY OTHER ITEMS AROUND A CHILD'S NECK OR ON THE CRIB PARTS. **DO NOT** PLACE CRIB NEAR WALL HANGINGS HAVING STREAMERS OR RIBBONS WHICH MAY BE ACCESSIBLE TO CHILD. BOTH OF THESE CIRCUMSTANCES COULD CAUSE STRANGULATION.
- WITH THE SPRING AND MATTRESS IN THE HIGHEST POSITION AND THE DROP SIDE IN THE DOWN POSITION, BE ABSOLUTELY SURE THAT THE TOP OF THE DROP SIDE IS AT LEAST 3 INCHES HIGHER THAN THE TOP SURFACE OF THE MATTRESS. IF IT IS NOT, LOWER THE MATTRESS SUPPORT TO THE NEXT HIGHEST POSITION.
- MATTRESS SUPPORT IS ONLY TO BE USED IN THE THREE POSITIONS ALLOWED BY THE HOLES IN THE HEADBOARD AND CHEST OF DRAWERS. MATTRESS SUPPORT MUST ALWAYS BE ATTACHED IN EACH POSITION WITH ALL HARDWARE, AS INDICATED IN INSTRUCTIONS. **NEVER USE MATTRESS SUPPORT WITHOUT ALL PROVIDED HARDWARE INSTALLED.**

- ALWAYS USE A FULL-SIZE CRIB MATTRESS MEASURING 51-5/8 INCHES LONG BY 27-1/4 INCHES WIDE AND 6 INCHES THICK. ONLY MATTRESSES OF THIS SIZE ARE TO BE USED WITH TODDLER BED.
- IF GUARDRAILS ARE USED AS THE MATTRESS CONTAINMENT MEANS, THE GUARDRAILS PROVIDED MUST BE USED.
- NEVER USE TODDLER BED WITHOUT ALL MATTRESS SUPPORT HARDWARE SECURELY IN PLACE AND MATTRESS SUPPORT IN ITS THIRD AND LOWEST POSITION.
- TODDLER BED IS DESIGNED TO BE USED BY A CHILD WITH A MAXIMUM WEIGHT OF 50 LBS. AND MINIMUM AGE OF 15 MONTHS. CHILDREN NOT MEETING BOTH OF THESE LIMITATIONS SHOULD NOT USE TODDLER BED.
- **DO NOT** USE A WATER MATTRESS WITH THIS CRIB.
- REPLACE TEETHING RAIL IF DAMAGED OR LOOSE.

IMPORTANT

- BEFORE USING THIS CRIB, PLEASE RECHECK ALL SCREWS AND BOLTS TO BE SURE THEY ARE FASTENED SECURELY. A PERIODIC CHECK SHOULD BE MADE TO BE SURE THESE ITEMS REMAIN PERFECTLY TIGHT.
- PERIODICALLY REMOVE LOWEST DRAWER IN CHEST TO CHECK BOLT WHICH SECURES FRONT CORNER OF MATTRESS SUPPORT. BOLT SHOULD BE TIGHTENED AS NECESSARY AND REMAIN PERFECTLY TIGHT AT ALL TIMES WHILE MATTRESS SUPPORT IS IN ITS LOWEST POSITION.
- USE OF A VAPORIZER NEAR FURNITURE WILL CAUSE WOOD TO SWELL AND FINISH TO CRACK.
- **DO NOT** STORE CRIB IN NON-AIRCONDITIONED AREAS WHERE TEMPERATURES AND CONDITIONS ARE EXTREME. UNREGULATED HEAT, COLD, AND HUMIDITY, SUCH AS IN GARAGES OR UNIMPROVED BASEMENTS MAY CAUSE THE WOOD TO CRACK AND GLUE JOINTS TO LOOSEN RESULTING IN STRUCTURAL FAILURE.
- LIFT THE CRIB SLIGHTLY WHEN MOVING ON CARPET TO PREVENT STRESS OR POSSIBLE BREAKAGE.
- NO RETURN OF THIS MERCHANDISE WILL BE ACCEPTED BY THE MANUFACTURER WITHOUT PRIOR WRITTEN AUTHORITY BY THE PARTS AND SERVICE DEPARTMENT LISTED BELOW.
- **DO NOT** USE DRESSER TOP AS A TABLE FOR LAMPS OR OTHER OBJECTS WHICH COULD BE DANGEROUS WITHIN REACH OF CHILD.



8100 West 30th Court
 Hialeah FL 33018-3820
 TEL. 1(800) 822-6748 FAX 1(800) 330-2353
 e-mail: service@kinderkraft.com
 web site: <http://www.kinderkraft.com>

PART DRAWINGS

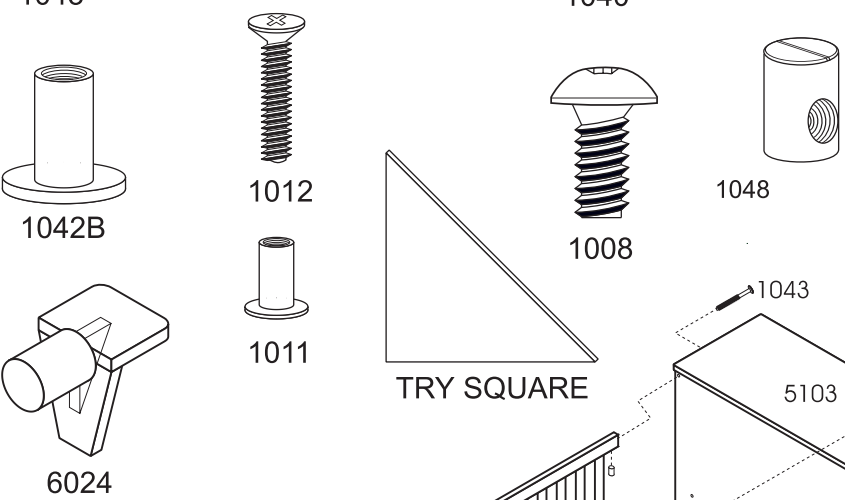
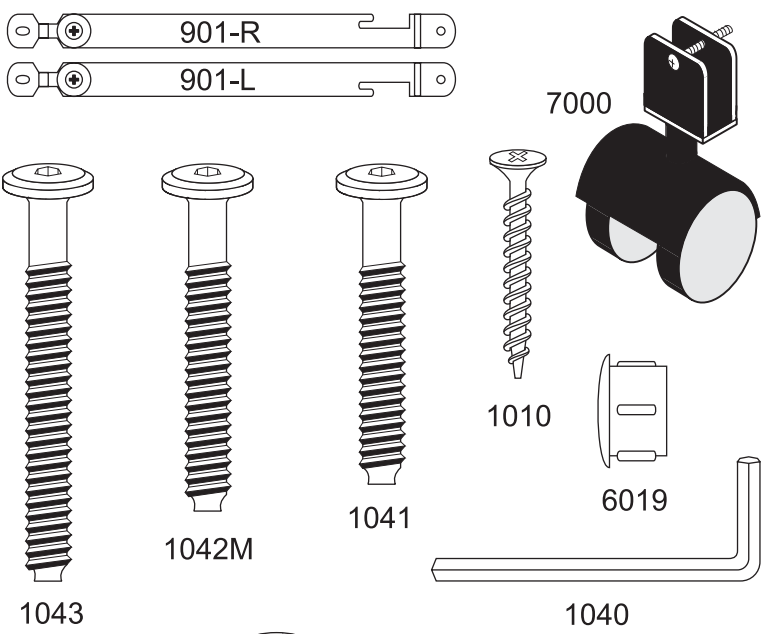

PART LIST

PART No.	DESCRIPTION	QTY
1010	WOOD SCREW 6 x 1.1/4"	18
1011	BINDING POST NUT	4
1012	BINDING POST BOLT	4
1040	ALLEN WRENCH	2
1041	BOLT 1/4"-20 x 1"	2
1042M	BOLT 1/4"-20x1.3/8"	1
1042B	CAP NUT	2
1043	BOLT 1/4" x 20 x 2"	4
1048	INSERT NUT	2
6019	PLUG	8
6024	SHELF SUPPORT	4
7000	CASTER	4
901-L	LEFT METAL SLIDE BRACKET	1
901-R	RIGHT METAL SLIDE BRACKET	1
-	TRY SQUARE	2
1008	BOLT 1/4x20x1/2	2

LIST OF COMPONENTS

PART NUMBER	DESCRIPTION	QTY
5103-A	HEADBOARD	1
5103-B	FOOTBOARD	1
5103-C	FRONT DROP SIDE	1
5103-D	STATIONARY RAIL	1
5103-E1	MATTRESS SUPPORT	1
5103-E2	SUPPORT PLATFORM	1
5103-F	BASE FRONT	1
5103-G	BASE BACK	1
5103-H	DIVIDING SUPPORT	1
5103-P1	DRAWER FRONT	2
5103-P2	RIGHT DRAWER SIDE	2
5103-P3	LEFT DRAWER SIDE	2
5103-P4	DRAWER BACK	2
5103-P5	DRAWER BOTTOM	2
5103	CHEST OF DRAWERS	1

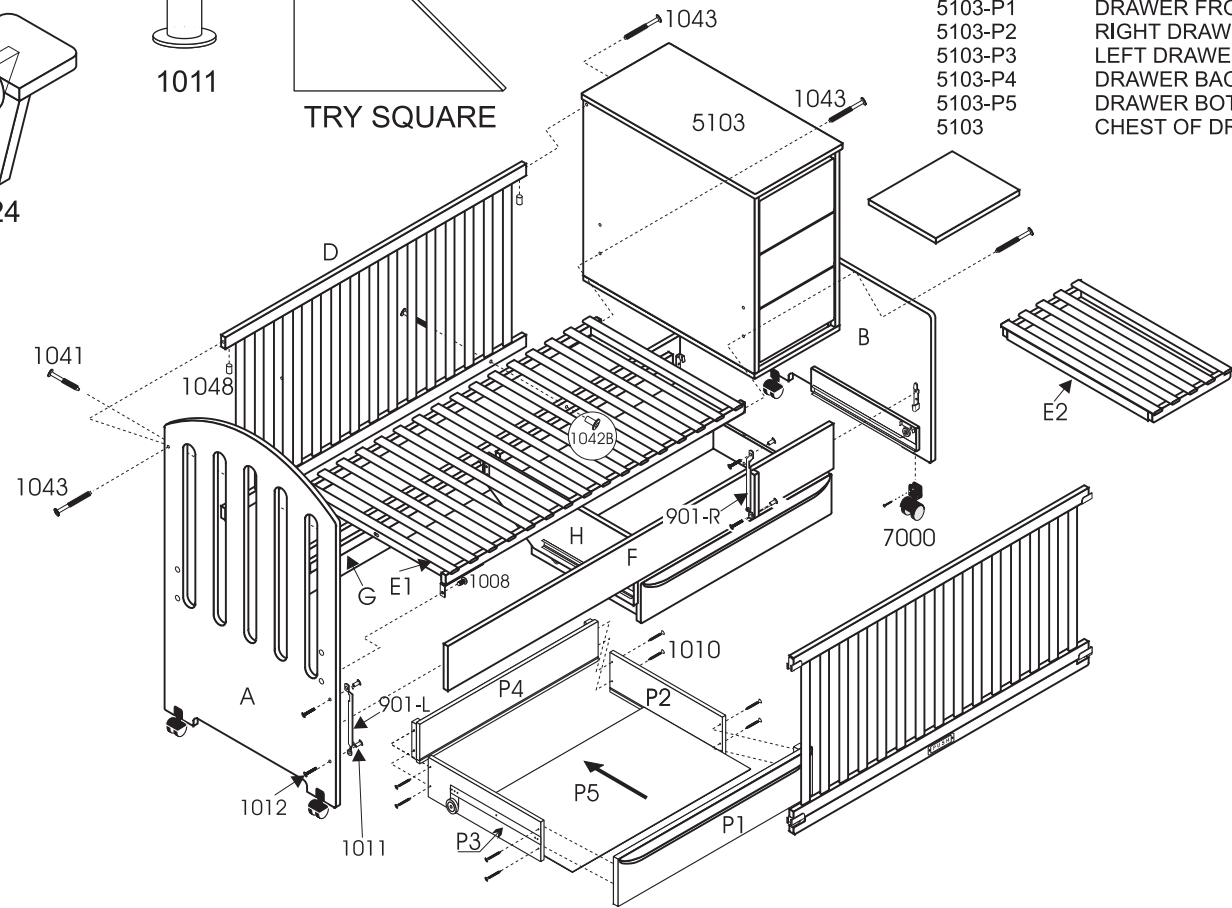

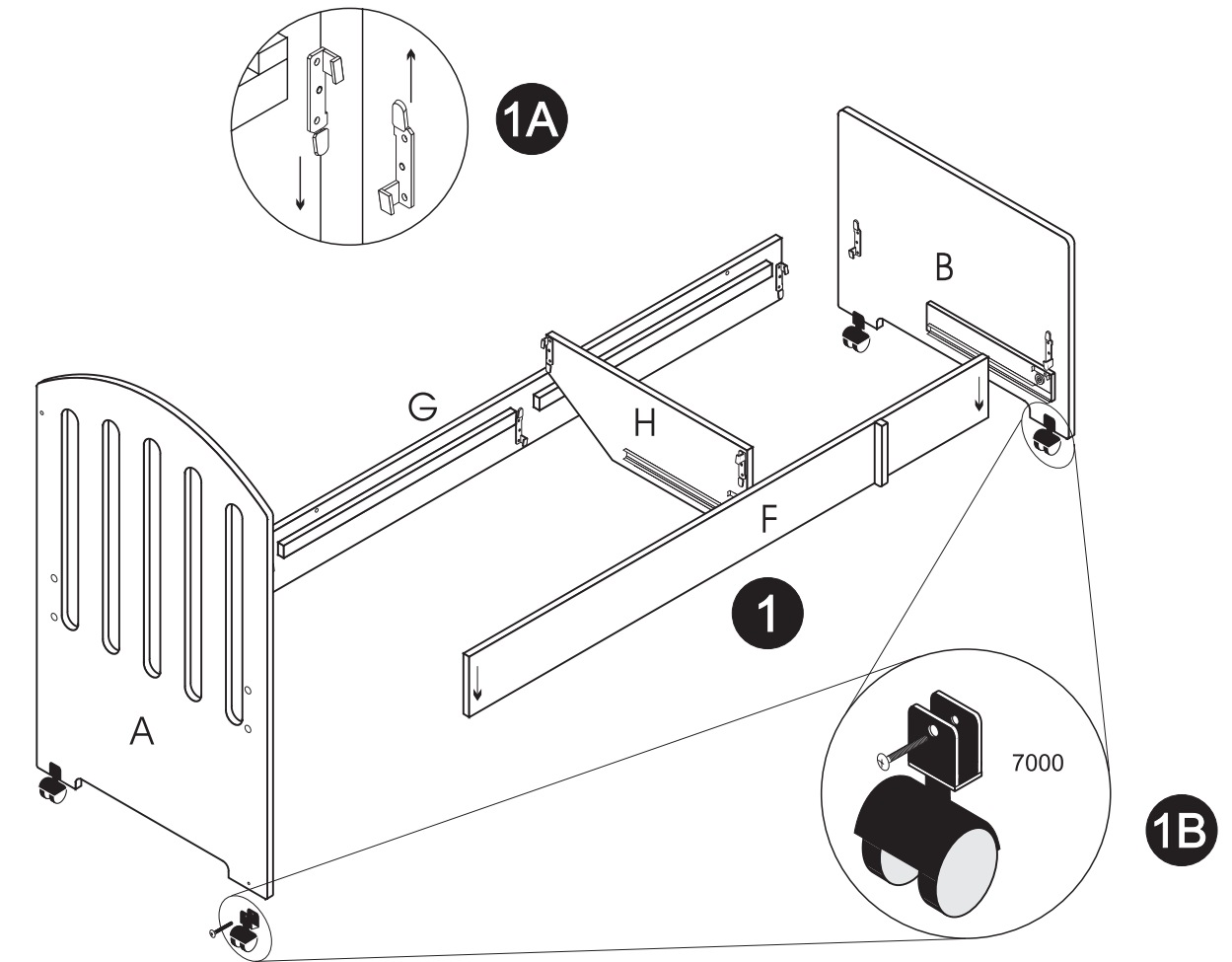

STEP #1

BEGIN BY IDENTIFYING EACH COMPONENT AND PART AS SHOWN. ASSEMBLE BASE BY SLIPPING THE BASE BACK TOGETHER WITH FOOTBOARD AND HEADBOARD. ADD THE BASE FRONT AND DIVIDING SUPPORT. ALL ARE ATTACHED BY SLIPPING TOGETHER THE JOINING DEVICES ATTACHED TO EACH PIECE.(SEE FIG 1A) PLACE THE PLYWOOD TRY SQUARE WE HAVE PROVIDED IN EACH CORNER OF THE PLATFORM TO CHECK FOR SQUARENESS. THE CASTERS SHOULD BE PLACED TWO EACH ON FOOTBOARD AND HEADBOARD. EACH WILL ALIGN WITH A PRE-DRILLED HOLE FOR ITS SECURING BOLT.(SEE FIG 1B) SECURING BOLT SHOULD ENTER FROM THE OUTSIDE THROUGH THE LARGER HOLE FIRST, THEN TIGHTEN INTO THE SMALLER THREADED INSIDE HOLE IN THE BLACK "U"-CLIP.

STEP #2

CONNECT THE LEFT AND RIGHT DRAWER SIDES TO THE DRAWER FRONTS WITH FOUR SCREWS #1010. WITH THE DRAWER FRONTS FACING DOWN, INSERT THE DRAWER BOTTOM. ATTACH THE DRAWER BACK WITH FOUR SCREWS # 1010. DRAWER SQUARENESS CAN BE CHECKED WITH THE PLYWOOD TRY SQUARE AS IN STEP #1.

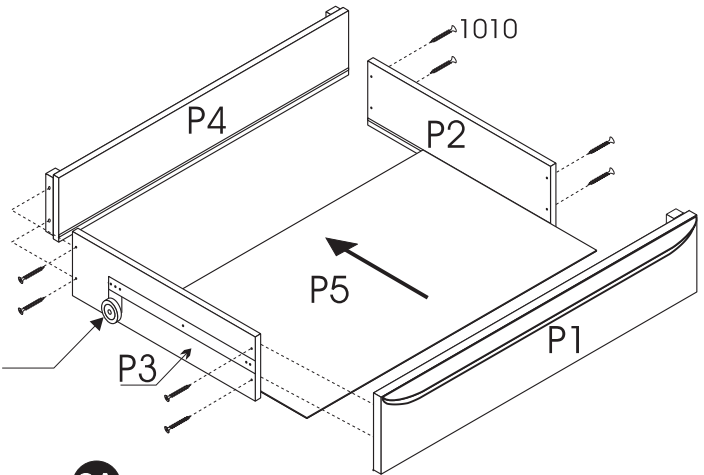

BE SURE NYLON WHEEL IS TOWARDS THE DRAWER BACK!

2A

INSERT THE COMPLETED DRAWERS IN BASE ASSEMBLY AND CHECK THAT THEY RUN SMOOTHLY.

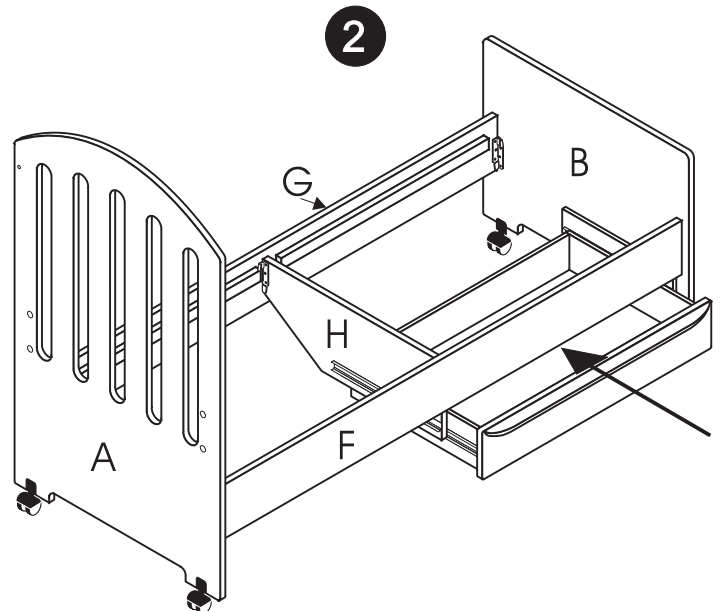

STEP #4
INSTALL THE STATIONARY RAIL TO THE CHEST AND HEADBOARD WITH TWO BOLTS #1043. THE BOTTOM PART OF THE BACK RAIL IS SECURED WITH TWO BOLTS #1041 INSERTED THROUGH THE LOWER HORIZONTAL RAIL, BASE BACK, AND INTO TWO CAP NUTS # 1042B.

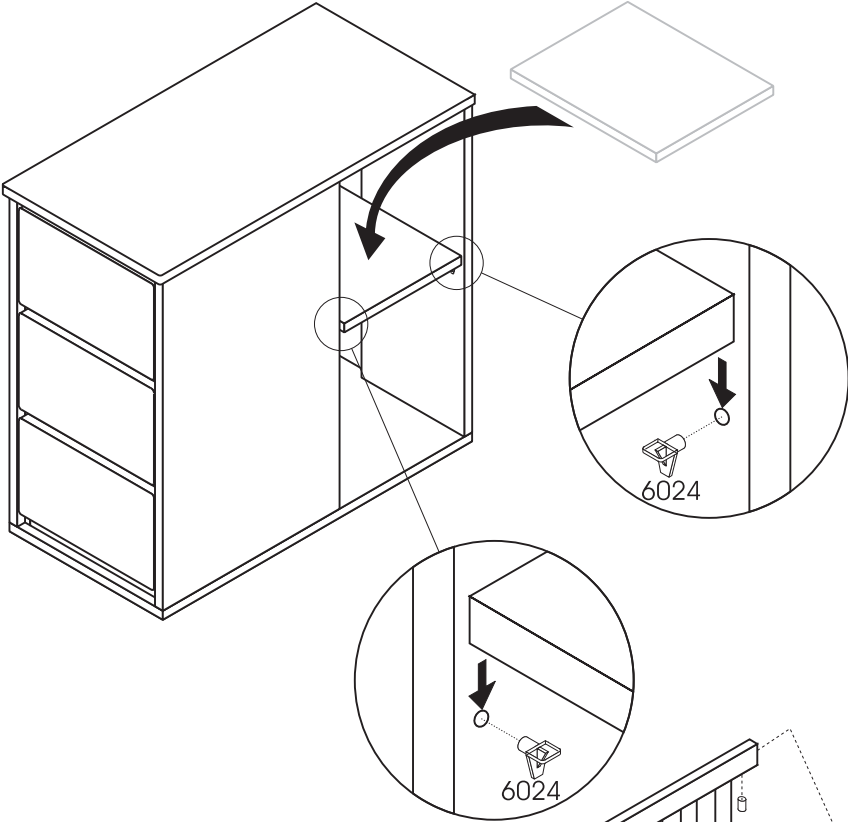

4

1041
1043

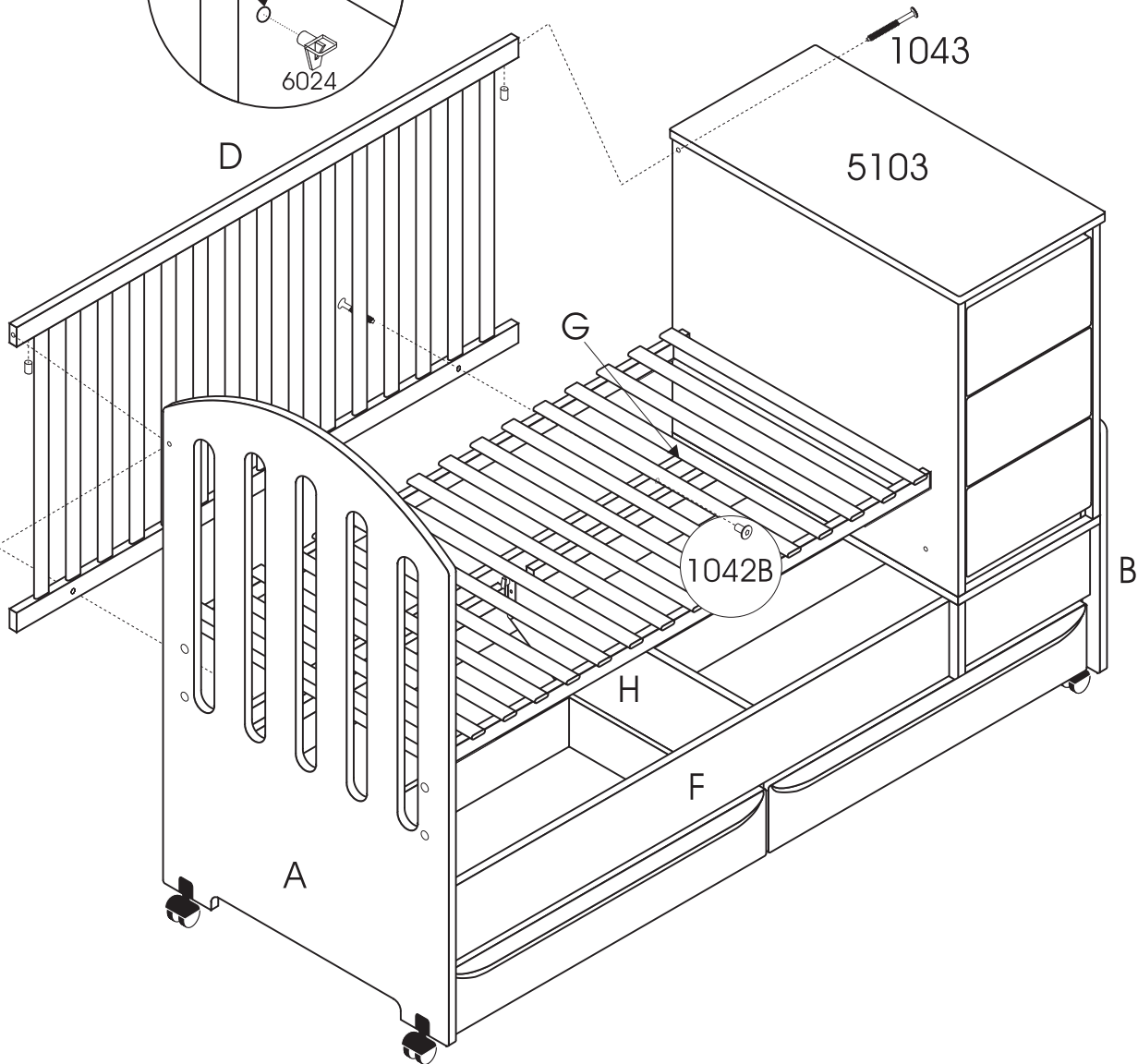

FACING THE TWO DRAWERS UNDER BASE, PLACE THE CHEST ON THE TOP RIGHT HAND SIDE OF THE BASE ASSEMBLY.

TO INSTALL THREE POSITION MATTRESS SUPPORT:
 FIRST REMOVE THE LOWEST DRAWER FROM THE CHEST OF DRAWERS. PULL DRAWER OPEN UNTIL IT STOPS. DEPRESS BOTH DRAWER RELEASE TRIGGERS IN CABINET WITH FINGERTIPS AND REMOVE DRAWER.

WITH THE HELP OF A SECOND PERSON, FIRST PLACE THE MATTRESS SUPPORT (5103-E1) INTO THE DESIRED HEIGHT ALIGNMENT HOLES IN THE HEADBOARD AND CHEST OF DRAWERS TOWARDS THE STATIONARY RAIL. FIX THIS SIDE INTO POSITION LOOSELY WITH ONE BOLT #1043 ON CHEST END ONLY AND ONE BOLT #1008 ON HEADBOARD END ONLY AS SHOWN.

THEN, TILT UP THE REMAINING SIDE OF THE MATTRESS SUPPORT UNTIL LEVEL, AND ALIGNED WITH CORRESPONDING HOLES TOWARDS THE FRONT DROP RAIL. TIGHTEN TWO BOLTS #1043 AND #1008 IN POSITION AS SHOWN.

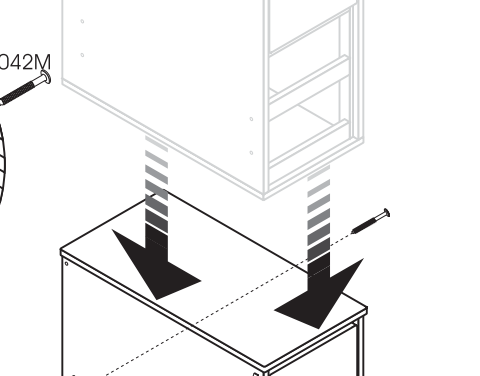
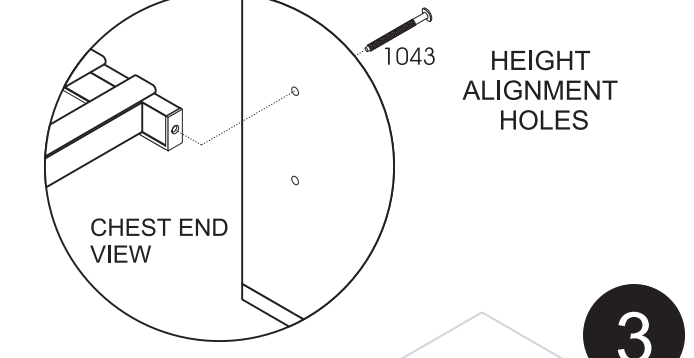
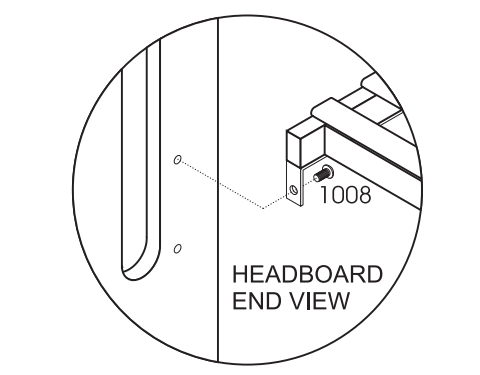

NOTE: TO PLACE MATTRESS SUPPORT IN ITS LOWEST POSITION, REMOVE BOLTS FROM BOTH ENDS OF MATTRESS SUPPORT. INSERT ONE END OF MATTRESS SUPPORT UNDER LOWER EDGE OF CHEST OF DRAWERS AND LOWER REMAINING END TO REST ON THE CLEATS PRESENT ON THE INSIDE OF THE BASE ASSEMBLY. FIX IN PLACE WITH ONE BOLT #1042M THROUGH CENTER OF HEADBOARD END.

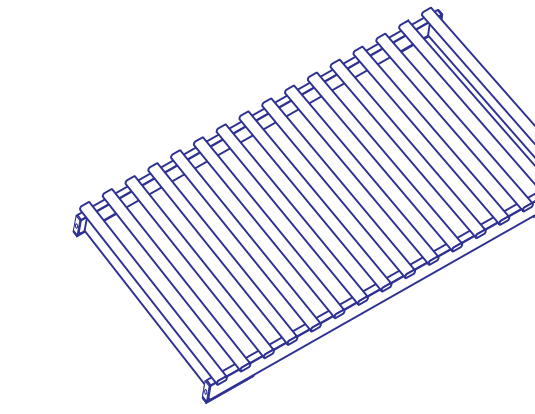
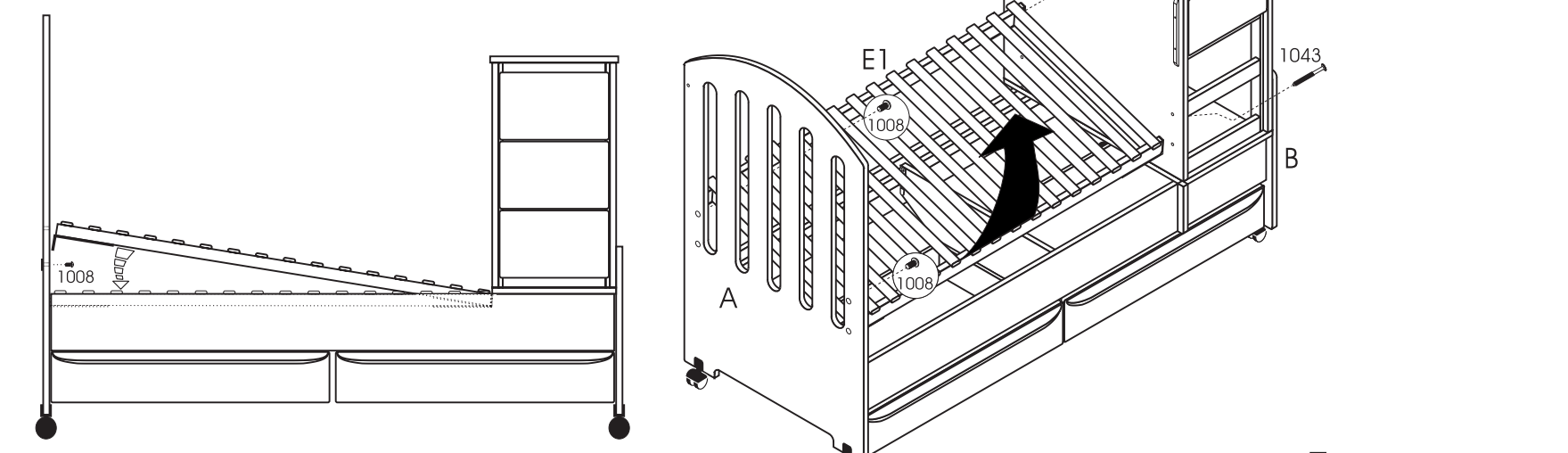
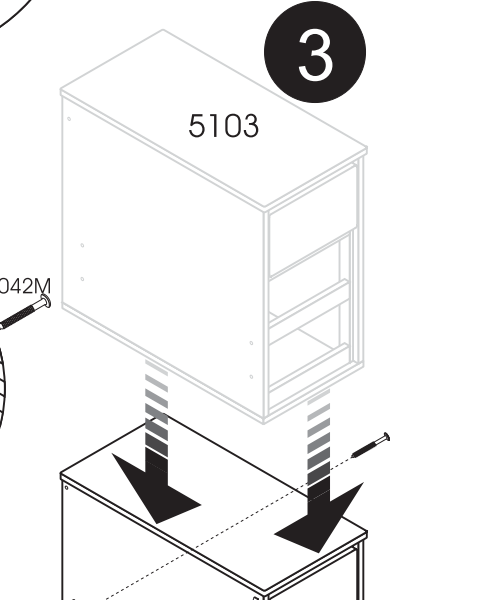
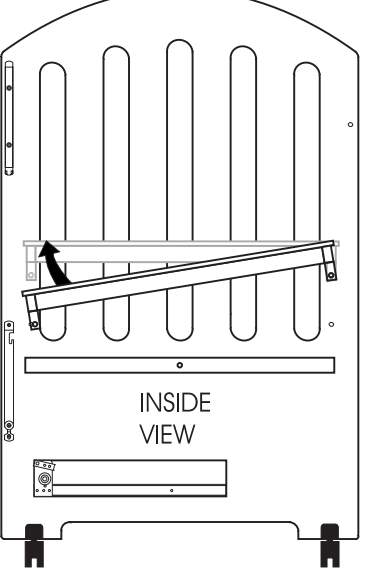

STEP #5

TO INSTALL FRONT RAIL, FIRST REMOVE THE TWO DRAWERS UNDER THE CRIB. INSTALL THE LEFT METAL SLIDE BRACKET (901-L) TO THE HEADBOARD. NEXT, INSTALL THE RIGHT METAL SLIDE BRACKET (901-R) TO THE LOWER FRONT OF THE CHEST OF DRAWERS AND BASE FRONT. BE ABSOLUTELY SURE THAT THE CUT OUT SPACE IN EACH BRACKET FACES INWARD TOWARD THE CRIB. THESE SHOULD BE PLACED EXACTLY AS SHOWN IN DRAWING

REMOVE THE RUBBER BUMPERS. THE FRONT RAIL SHOULD BE SLID UPWARD ONTO ALL FOUR CORNER SLIDE TRACKS SIMULTANEOUSLY WITH THE PLASTIC "PUSH" PLATE FACING OUT. THIS SHOULD BE DONE WITH CARE THAT THE SPRING LOADED NYLON FINGER DOES NOT BECOME WEDGED AGAINST THE LOWER METAL SLIDE BRACKETS. THE SPRING FINGER SHOULD ALWAYS RIDE FREELY AND IN FRONT OF LOWER SLIDE BRACKETS. (SEE DRAWING 5B). FINALLY, THE RUBBER BUMPERS SHOULD BE REINSTALLED IN THE LOWER METAL SLIDE BRACKETS WITH THE RAIL LOCKED IN THE "UP" POSITION.

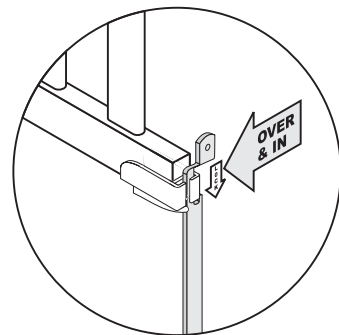
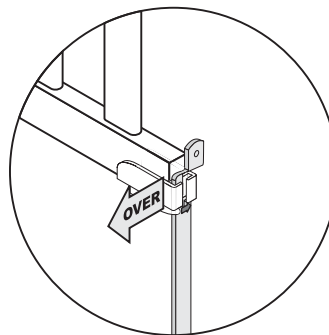
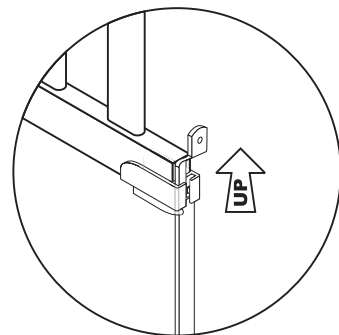
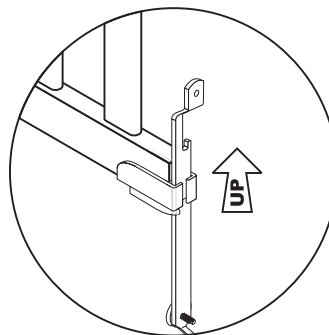
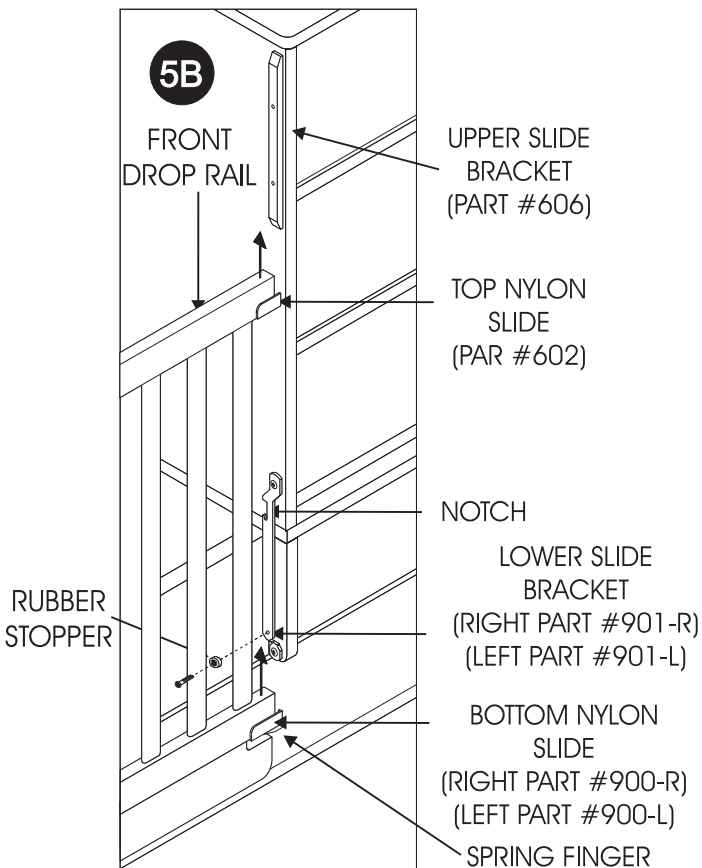
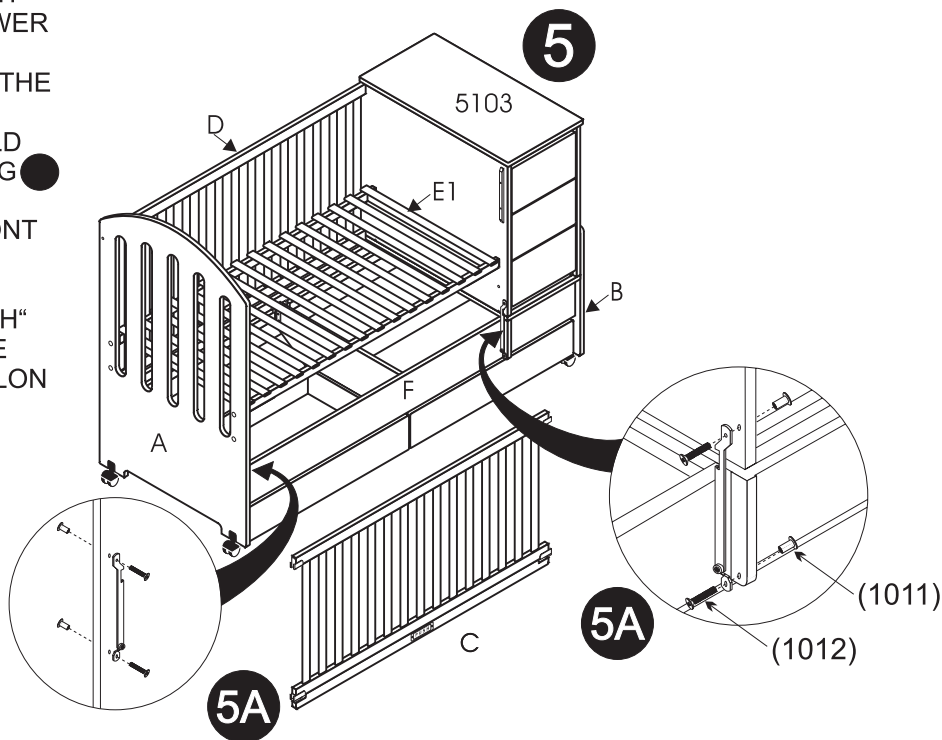

THE FRONT DROP RAIL CAN NOW BE TESTED

IT IS RECOMMENDED THAT THE USER FACE WITH EITHER OF THEIR SIDES TOWARD THE CRIB RAIL AS SHOWN BY THE KINDERKRAFT LION.

- **TO LOWER**, LIFT IN THE EXACT CENTER OF THE RAIL **1** AND THEN APPLY INWARD PRESSURE WITH THE CALF OF THE LEG AT THE CENTER OF THE DROP RAIL **2**. THE RAIL SHOULD MOVE IN TOWARDS THE CRIB AND OUT OF THE UPPER CUT-OUT NOTCHES THEN SLIDE EASILY DOWN TO REST ON THE RUBBER BUMPERS.
- **TO RAISE**, LIFT IN THE EXACT CENTER OF THE RAIL. LOOK AND LISTEN TO INSURE THAT THE RAIL LOCKS IN THE UP POSITION. THE LOWER GUIDE ASSEMBLY SHOULD ENTER COMPLETELY INTO THE NOTCHES IN THE BOTTOM METAL SLIDE BRACKETS ON BOTH SIDES OF THE FRONT RAIL. **3** **3**

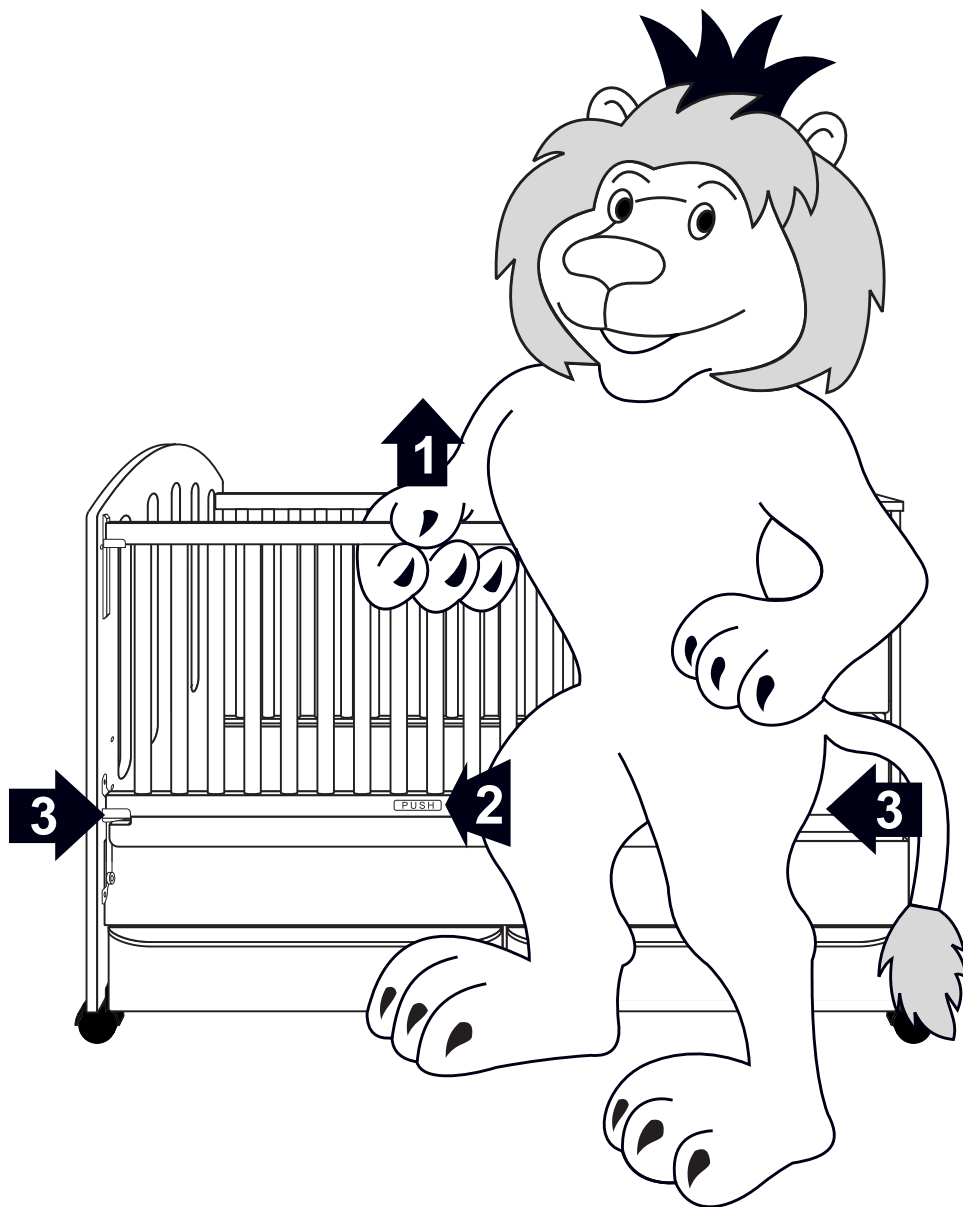

TODDLER BED ASSEMBLY INSTRUCTIONS

IF CONVERTING ASSEMBLED CRIB TO FORM TODDLER BED. THE FOLLOWING STEPS SHOULD BE USED:

STEP #1
REMOVE RUBBER BUMPERS FROM BOTH LOWER METAL SLIDE BRACKETS. (SEE STEP 5). LOWER AND COMPLETELY REMOVE FRONT DROP RAIL (5101-C).

STEP #2
BE SURE MATTRESS SUPPORT IS IN THE THIRD AND LOWEST POSITION AND BOLTED IN PLACE THROUGH THE HEADBOARD AS SHOWN

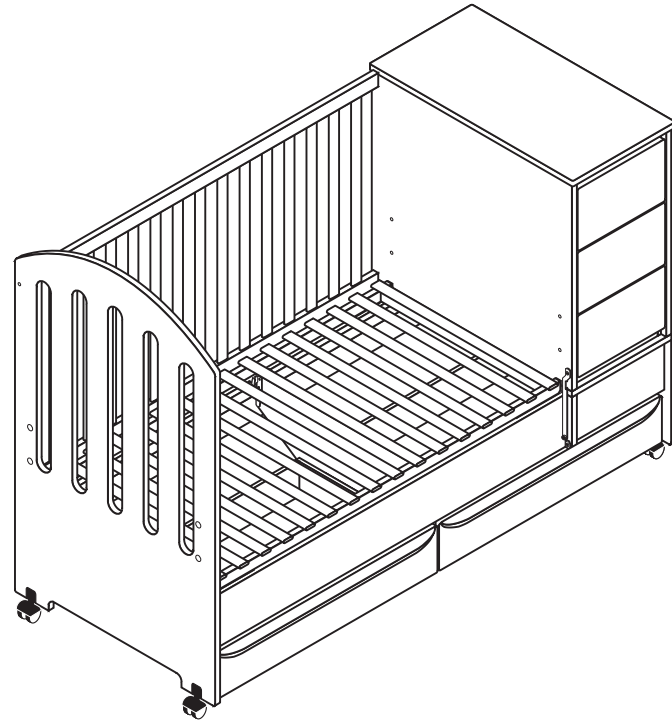

YOUTH BED ASSEMBLY INSTRUCTIONS

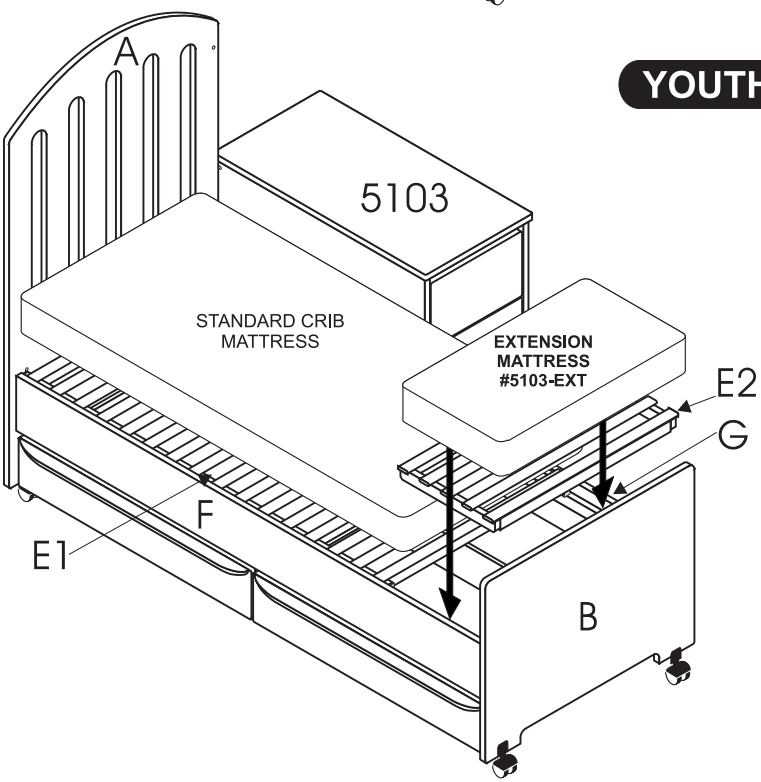

NOTE:

STANDARD CRIB, EXTENSION, AND. YOUTH MATTRESS ALL SOLD SEPARATELY

CRIB'N JUNIOR SHOWN IN JUNIOR (YOUTH) BED CONFIGURATION



8100 West 30th Court
Hialeah, FL 33018-3820

TEL. 1(800) 822-6748 FAX 1(800) 330-2353

e-mail: service@kinderkraft.com

web site: <http://www.kinderkraft.com>

