

## Operation

Tempmatic Climate Control	22	Seat Belts and Supplemental	
Car Keys	28	Restraint System (SRS)	38
Opening the Doors	29	Steering Lock	48
Locking and Unlocking of		Exterior Lamp Switch	50
Doors	29	Combination Switch	51
Central Locking System	30	Shelf below Rear Window	52
Anti-Theft Alarm System	31	Inside Rear View Mirror	52
Manual Seat Adjustment,		Exterior Rear View Mirrors	53
Front	32	Sun Visors	54
Power Seats, Front	33	Interior Lamps	54
Orthopedic Seat Backrest	35	Rear Window Defroster	55
Armrest (Front Seats)	36	Lighter	56
Armrest (Rear Bench Seat)	36	Sliding Roof with Rear	
Head Restraints, Rear	36	Pop-Up Feature	56
Heated Seats	37	Power Windows	57
		Antenna	58
		Cellular Telephone	58

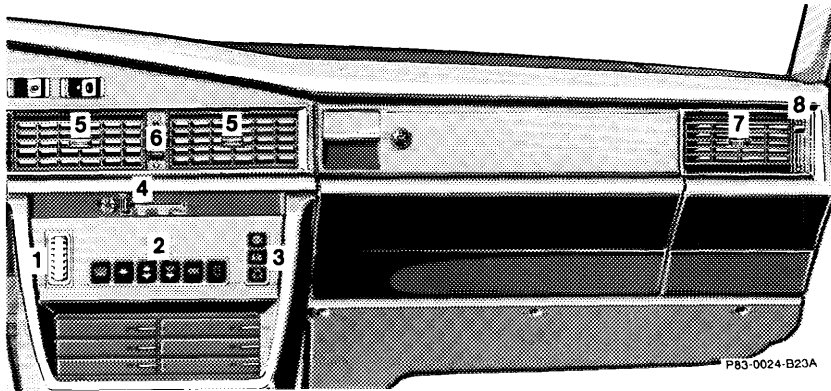



### Tempmatic Climate Control

The engine must be running for the climate control system to operate.

- 1 Temperature selector
- 2 Pushbuttons for function selection (only press individually)

 = Defrost

 = Defog

 = Heating and cooling

 = Normal heating



- 3 Air conditioning mode control

 = Normal cooling or fresh air ventilation

 = Off (air supply off)

 = Dehumidifying

 = Normal setting

 = Recirculated air switch (red indicator lamp in the button comes on. The button returns to initial position). If either button  or  are depressed, the air conditioning compressor is switched on.

- 4 Fan speed control lever

- 5 Adjustable air outlets

- 6 Volume control lever for adjustable air outlets (5)

- 7 Adjustable air outlets

- 8 Volume control lever for adjustable air outlets (7)

The button symbols light up when the vehicle's exterior lamps are turned on. The symbol is brighter when depressed.

Close all windows and the sliding roof to ensure proper operation of the system. Air outlet temperature is controlled automatically.

Note:

The air conditioner removes considerable moisture from the air during operation. It is normal for water to drip on the ground from the underbody.

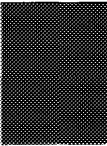

### Air Distribution

Air conditioned, warmed, or fresh air may be directed to the foot area, the windshield, and the side outlets (7). The center outlets (5) are for non-heated air only.

The air volume through the center outlets (5) and side outlets (7) can be varied with levers (6) and (8) respectively. Pushing the lever up opens the air outlets completely.

### Temperature Selection



Use the temperature selector to set the desired temperature. The selected temperature is reached as quickly as possible and maintained. Use a basic setting of "72". Refine your setting only in small steps to avoid large temperature fluctuations.

Turning downwards (notched-in) = maximum cooling or fresh air dependent on push button selection of the air conditioning mode control.

Turning upwards (notched-in) = maximum heating.

### A/C Mode Control Switch





Position  = Normal cooling, the air conditioning compressor is switched on.

The vehicle may be heated or cooled as desired. The compressor comes on if the vehicle's interior temperature exceeds the selected temperature. The selected temperature is then maintained by regulating the compressor's running time.

Position  = Dehumidifying, the air conditioning compressor is switched on.

The climate control system works at maximum capacity, removing moisture from the air. This mode is recommended during humid weather and when windows must be defogged from inside.

Position  = Recirculated air (buttons  or  must not be depressed).





Recirculated air switch pressed:

- Cooling Mode  
If the outside temperature exceeds approx. 59° F (15° C), the system will automatically change from recirculated air to fresh air after 30 minutes.
- Heating Mode  
If the outside temperature is less than approx. 59°F (15° C), the system will automatically change from recirculated air to fresh air after 5 minutes.

This setting can also be used if annoying odors or dust are entering the car's interior.

At high outside temperatures the air conditioning system is automatically in the recirculated air mode, providing increased cooling.

## Fan Speed Selection



When pushing one of these buttons  ,  ,  or button  , the fan speed will correspond to the particular position of the fan speed control lever (4).

The volume of fresh air supplied to the vehicle interior can be increased by pushing lever (4) to the right.

The fan speed may be changed by moving lever (4) to position “I”, “II” or “max”.

Function  = Maximum fan speed engaged.

## Fast Cooling

- Turn temperature selector wheel (1) and lock in the lower end position.
- Push button  or  in mode control (3).
- Push  button.
- Move fan speed control lever (4) to far right “max” position.
- Open adjustable air outlets (5) and (7) completely by pushing up levers (6) and (8), respectively.
- Close windows and sliding roof completely.

Note:

Open the windows and/or sliding roof long enough to let hot air inside the car escape. This helps reduce the time the air conditioner must run before the car cools. Then, close windows and/or sliding roof and allow air conditioner to operate to its full capacity.

## Examples of Air Flow Adjustments

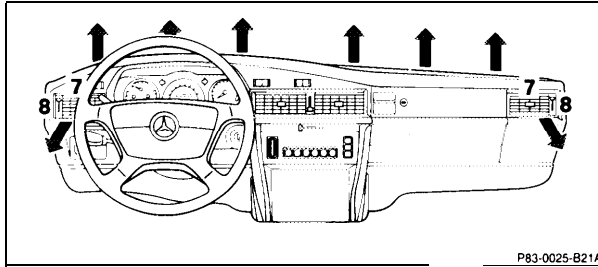

 Press to defrost or quickly defog windows.

Maximum heated air is directed to the windshield and side windows, independent of the temperature setting (1), mode control (3) and fan speed control lever (4) position. The air volume through outlets (7) may be adjusted with levers (8) as desired.

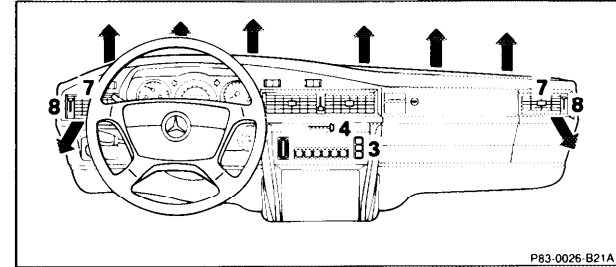

 Press to defog the inside of the windshield.

Air is directed to the windshield in the heating or cooling mode. Press button  of mode control (3) and increase fan speed for a short period with lever (4). Adjust levers (8) for the desired air flow through outlets (7).

It is possible for condensation to form on the outside of the windshield in humid weather in this mode. If this happens, change the air flow or decrease the fan speed.

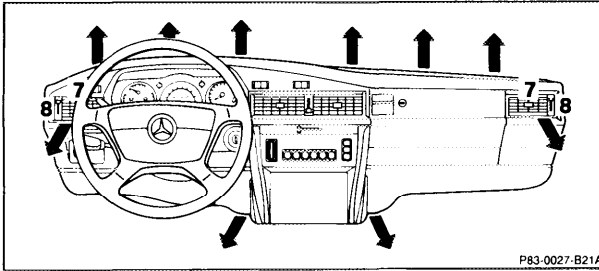

P83-0027-B21A

 Press for heating.

In this type of operation, air is directed to the windshield and the foot area. The air outlets (7) may be opened or closed with levers (8) as desired. If the ambient temperature is above 32°F (0°C) the air conditioning compressor may switch on automatically to dry the heated air.

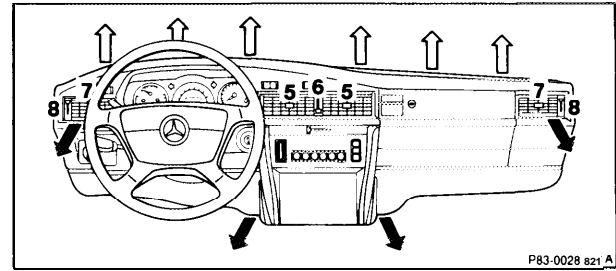

P83-0028 821 A

 Press for normal heater operation.

Most of the air is directed to the foot area during heater operation. A small amount of air is directed to the windshield, just enough to keep it from fogging up during normal weather conditions. The air outlets (5) and (7) may be opened or closed with levers (6) and (8) respectively as desired. Only non-heated air is directed through outlets (5).

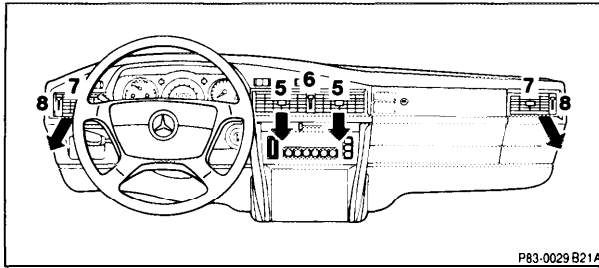

**B** Press for fresh air ventilation or air conditioning.

For taking in fresh air or during air conditioner operation, the air is directed to outlets (5) and (7). Adjust the air flow with levers (6) and (8) respectively as desired.

**0** Off.

In this setting, the Tempmatic Climate Control is shut off, including the fresh air supply to the interior of the car (to prevent entrance of odors, i. e. while driving through tunnels etc. or to prevent the entrance of water from automatic car wash). Use this setting only temporarily while driving with windows and sliding roof closed since the vehicle's normal interior airflow will be disrupted.

**Important!**

Inappropriate repair work may cause refrigerant (CFC) to escape into the atmosphere and contribute to the depletion of the earth's ozone layer.

Repairs should always be performed by a qualified technician, and refrigerant should be collected in a recovery system for recycling.

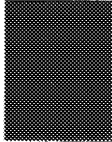

Operation

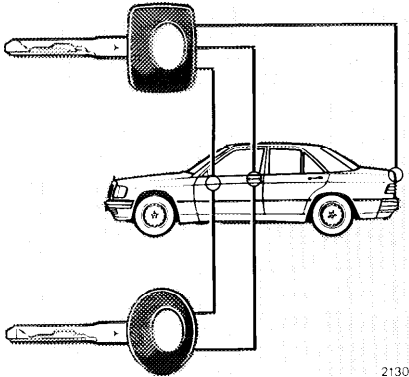

### Car Keys

Included with your vehicle are two master keys, one valet key and one flat (master) key.

**Master Key** – square head – fits all locks on the car. Arms/disarms the anti-theft alarm system.

Note:

Do not give the master key to an unauthorized person.

**Valet Key** – round head – works only in the door locks and the steering lock. Arms/disarms the anti-theft alarm system. The valet key will not fit the trunk or glove box locks. This key should be used whenever the car is left with an attendant. Be sure to lock glove box and trunk with the master key.

### Flat Key

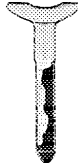

The flat key fits all vehicle locks. Arms/disarms the anti-theft alarm system. We recommend that you carry the flat key with you and keep it in a safe place so that it is always handy. Never leave the flat key in the vehicle.

### Obtaining Replacement Keys

Your vehicle is equipped with a theft deterrent locking system requiring a special key manufacturing process. For security reasons, replacement keys can only be obtained from your authorized Mercedes-Benz dealer.

#### **Warning!**

**When leaving the vehicle always remove the key from the steering lock. Do not leave children unattended in the vehicle. Unsupervised use of vehicle equipment may cause serious personal injury.**



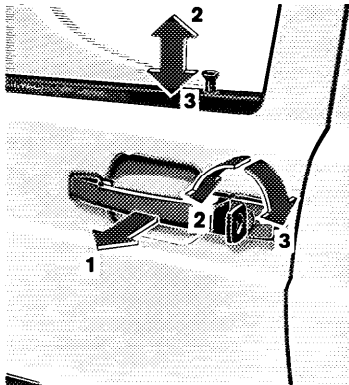

9925

### Opening the Doors

From outside: pull handle (1) outwards.

From inside: pull handle (4) in door trim panel.

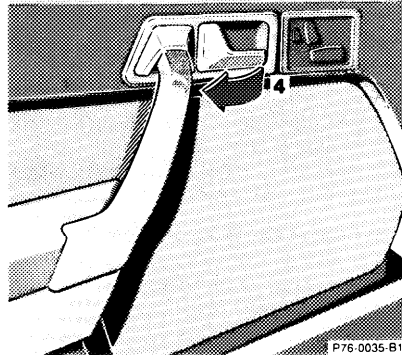

P76.0035-B13

### Locking and Unlocking of Doors

From the outside: turn key.

From the inside: actuate door lock button.

- 2 Unlocking
- 3 Locking

When the rear door lock buttons are down, the rear doors cannot be opened from the outside or the inside, unless the door lock buttons are first pulled up.

One cannot lock:

- the driver's door if it is open
- any door if the door latch has not engaged fully. In this case open the door and close it again.

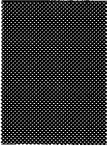

## Central Locking System

The entire vehicle may be locked or unlocked with the central locking system by:

- Using the master or valet key in either front door.
- Using the master key in the trunk lock.
- Pushing down or pulling up the interior door lock button at either front door.

The central locking system locks or unlocks all doors, trunk lid and fuel filler flap simultaneously.

### Doors

When you lock the car, all door lock buttons should move down. If any one stays up, the respective door is not properly closed. You should then unlock the car, open and reclose this door, and lock the car again.

The central locking system can be engaged from the driver's door lock button, provided the door is completely closed. It can also be engaged from the front passenger door if the ignition key is removed, or the key is inserted in the steering lock without having been turned (key in position 0).

If the car has been locked from the outside, the anti-theft alarm (if so equipped) will come on if a door is opened from the inside.

### Trunk

To unlock the trunk with the central locking system, turn the master key in the trunk lock completely to the left and return it to the vertical position. Push in trunk lock button and open the trunk. To lock the trunk, turn the master key completely to the right and return it to the vertical position.

The trunk can remain locked while the central locking system is unlocked (e. g. while driving or when leaving the car in a situation where it must be driven using the valet key but you wish the trunk to remain locked at parking lots, workshops etc.). Turn the master key completely to the right and pull it out in the horizontal position. Now the trunk can only be unlocked with the master key by turning it back completely to the left.

### Important!

If the trunk is unlocked with the master key, the doors and fuel filler flap will also be unlocked. After closing the trunk, the central locking system must again be engaged using the key to relock the doors and fuel filler flap.

### Note:

If the fuel filler flap cannot be opened, refer to *Manual Release of Fuel Filler Flap* (see Index).

## Anti-Theft Alarm System

The anti-theft alarm is automatically armed or disarmed with the master key, valet key or flat key by locking or unlocking either front door or the trunk.

### Operation

Once the alarm system has been armed, the exterior vehicle lamps will flash and the horn will sound intermittently when someone:

- opens a door,
- opens the trunk,
- opens the hood,
- removes the radio,
- switches on or bridges the ignition circuit,
- steps on the brake pedal.

The alarm will last approximately 150 seconds in the form of blinking exterior lamps. At the same time an additional horn will sound intermittently for 60 seconds, pause for 30 seconds, and repeat for another 60 seconds.

The alarm will stay on even if the activating element (a door, for example) is immediately closed.

Note:

We recommend that you carry the flat key safely with you so that it is always handy. This key has the same function as the master key.

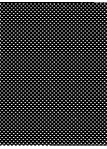

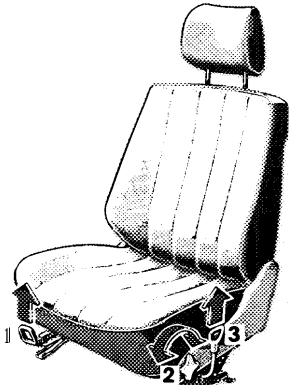

1266

### Manual Seat Adjustment, Front

- 1 Fore/aft adjustment
- 2 Seat cushion inclination adjustment
- 3 Seat height adjustment
- 4 Seat back adjustment

Fore/aft adjustment: lift handle (1); slide seat to desired position and allow handle to re-engage. Check for proper engagement before driving.

Inclination of seat cushion: turn handwheel (2) forward or backward.

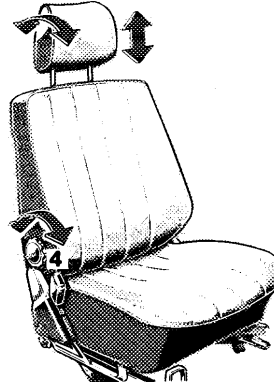

2115

Height of seat: raise lever (3); to raise seat, slide seat forward; to lower seat, slide seat backward; allow lever to re-engage. Check for proper engagement before driving.

Seat back position: turn handwheel (4). For full reclining of backrest, seat should be moved to one of the forward-most positions and head restraint removed. For driving, return backrest to upright position and push seat back. Replace head restraint.

Head restraint: to adjust the height of the head restraint, pull it slightly forward while lifting or pushing

down. Adjust head restraint to support the back of the head approximately at ear level. However, do not pull up the head restraint past the detent.

### Warning!

**Do not adjust the driver's seat while driving. Adjusting the seat while driving could cause the driver to lose control of the vehicle.**

**Never ride in a moving vehicle with the seat back reclined. Sitting in an excessively reclined position can be dangerous. You could slide under the seat belt in a collision. If you slide under it, the belt would apply force at the abdomen or neck. That could cause serious or even fatal injuries. The seat back and seat belts provide the best restraint when the wearer is in an upright position and belts are properly positioned on the body.**

**Never place hands under seat or near any moving parts while a seat is being adjusted.**

### Caution!

Do not remove head restraints except when mounting seat covers. For removal refer to *Head Restraints* in Index. Whenever restraints have been removed be sure to reinstall them before driving.

### Important!

Prior to operating the vehicle, the driver should adjust the seat height for proper vision as well as fore/aft placement and seat back angle to insure adequate control, reach, operation, and comfort. The head restraint should also be adjusted for proper height.

Both the inside and outside rear view mirrors should be adjusted for adequate rearward vision. Fasten seat belts. Infants and small children should be seated in a properly secured restraint system that complies with U.S. Federal Motor Vehicle Safety Standard 213 and Canadian Motor Vehicle Safety Standard 213.1.

All seat, head restraint, and rear view mirror adjustments as well as fastening of seat belts should be done before the vehicle is put into motion.

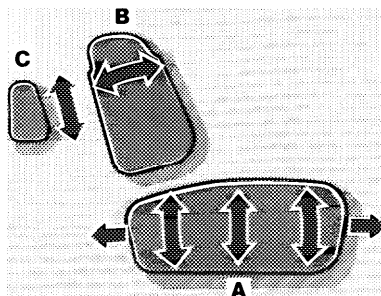

P91-0014-B13

### Power Seats, Front

The switches are located in each front door, if your vehicle is equipped with front power seats.

Turn key in steering lock to position 1 or 2 (with the driver's or front passenger's door open, the power seats can also be operated with the key removed or in steering lock position 0).

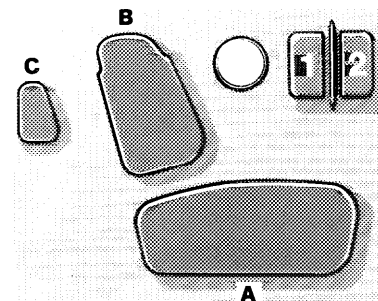

P91-0045-B13

Seat and head restraint adjustment:

**A** Seat cushion adjustment.

**B** Seatback adjustment.

**C** Head restraint adjustment.

Adjust head restraint to support the back of the head approximately at ear level. The head restraint can also be tilted forward by hand.

Note:

If the car is equipped with power head restraints, do not try to operate manually.

**Warning!**

**Do not adjust the driver's seat while driving. Adjusting the seat while driving could cause the driver to lose control of the vehicle.**

**Never ride in a moving vehicle with the seat back reclined. Sitting in an excessively reclined position can be dangerous. You could slide under the seat belt in a collision. If you slide under it, the belt would apply force at the abdomen or neck. That could cause serious or even fatal injuries. The seat back and seat belts provide the best restraint when the wearer is in an upright position and belts are properly positioned on the body.**

**Never place hands under seat or near any moving parts while a seat is being adjusted.**

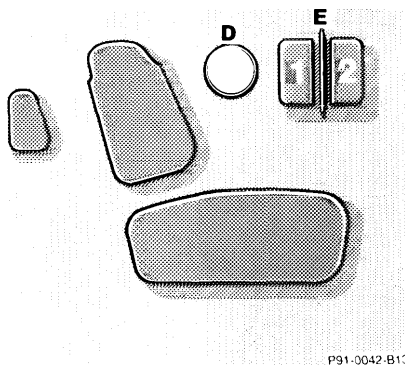

Storing seat/head restraint positions in memory:

**D** Memory button.

**E** Position buttons “1” and “2”.

Two sets of seat/head restraint positions may be programmed into memory. After the seat/head restraint are positioned, push memory button D, release, and within 3 seconds push position button “1”. A second set of positions for the same seat/head restraint can be programmed into memory by pushing first button D and then “2”.

Recalling seat/head restraint positions stored in memory:

To recall a seat/head restraint position, push position button “1” or “2” until seat/head restraint movement has stopped. For safety reasons, the seat/head restraint movement stops after releasing the position button.

**Caution!**

Do not remove head restraints except when mounting seat covers. For removal refer to *Head Restraints, Front, see Index*. Whenever restraints have been removed be sure to reinstall them before driving.

## Important!

Prior to operating the vehicle, the driver should adjust the seat height for proper vision as well as fore/aft placement and seat back angle to insure adequate control, reach, operation, and comfort. The head restraint should also be adjusted for proper height.

Both the inside and outside rear view mirrors should be adjusted for adequate rearward vision. Fasten seat belts. Infants and small children should be seated in a properly secured restraint system that complies with U.S. Federal Motor Vehicle Safety Standard 213 and Canadian Motor Vehicle Safety Standard 213.1.

All seat, head restraint, and rear view mirror adjustments as well as fastening of seat belts should be done before the vehicle is put into motion.

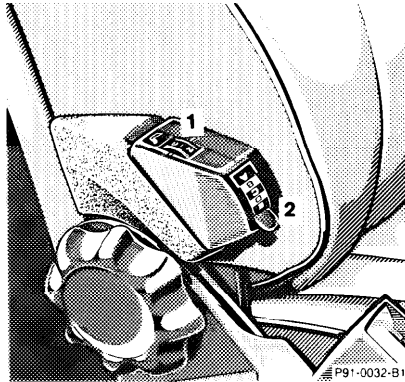

### Orthopedic Seat Backrest

- 1 Pressure regulator
- 2 Height regulator

Some models may be equipped with orthopedic seats. These seats have inflatable air cushions built into the backrest to provide additional lumbar support. The amount of cushion height and curvature may be adjusted after turning the key in steering lock to position 2.

The inflation pressure of the air cushion can be varied continuously between position "0" = without pressure, and position "4" = maximum pressure, by changing the pressure regulator (1) setting.

In addition, the cushion height may be changed to five different settings between position "A" = lowest setting, and "E" = highest setting, by varying the height regulator (2) adjustment.

If the engine is turned off, the last cushion setting is retained in memory, and automatically adjusts the cushion to this setting when the engine is restarted.

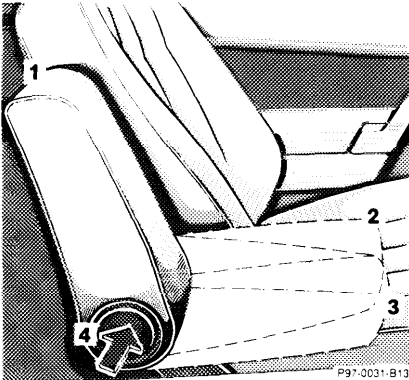

#### Armrest (Front Seats)

- 1 Armrest folded up.
- 2 For normally inclined seat back.
- 3 For extremely inclined seat back.
- 4 To adjust armrest downwards, press release button.

#### Warning!

**The arm rest does not suffice as a child restraint system. In case of a frontal collision a child can be catapulted forward over the locked arm rest.**

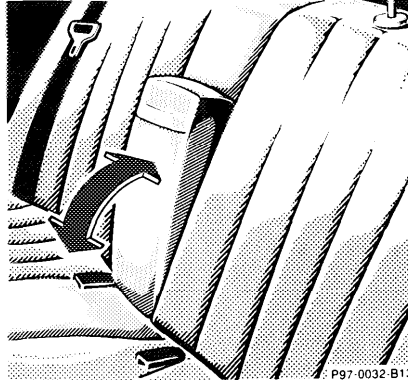

**Infants and small children should always be seated in a properly secured restraint system that complies with U.S. Federal Motor Vehicle Safety Standard 213 and Canadian Motor Vehicle Safety Standard 213.1.**

#### Armrest (Rear Bench Seat)

Pull down the armrest by its strap.  
For removal of rear seat cushion, see Index.

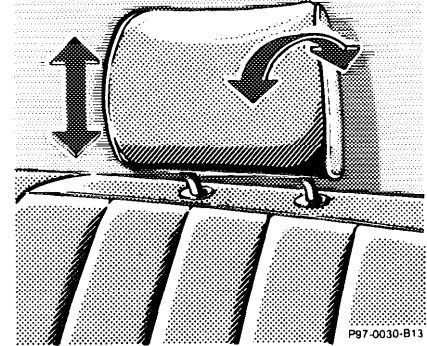

#### Head Restraints, Rear

Adjust head restraint to support the back of the head approximately at ear level. Do not extend the head restraint past the stop.

For removal of head restraint refer to *Head Restraints* in Index.



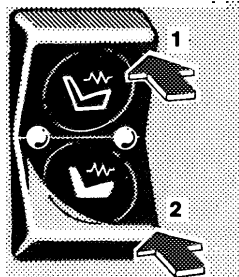

1264

## Heated Seats

1 Normal heating mode

2 Rapid heating mode

The seat heaters can be switched on with the keys in steering lock position 2.

### Heater operation:

Push in upper switch portion; position 1 = normal heating mode, one indicator lamp lights up.

Push in lower switch portion; position 2 = rapid heating mode, both indicator lamps light up.

After approximately 5 minutes in the rapid heating mode, the heater automatically switches to normal operation and only one indicator lamp will stay on.

### Turning off heater:

If one indicator lamp is on, press in upper part of switch, position 1.

If both indicator lamps are on, press in lower part of switch, position 2.

The heater automatically turns off after approximately 30 minutes of operation.

### Notes:

When in operation, the seat heater consumes a large amount of power. It is advisable not to use the seat heater longer than necessary.

The seat heaters may automatically switch off if too many power consumers are switched on at the same time, or if the battery charge is low. When this occurs, the indicator lamp in the switch will blink (both indicator lamps blink during rapid seat heating). The seat heaters will switch on again as soon as sufficient voltage is available.

If the blinking of the indicator lamps is distracting to you, the seat heaters can be switched off.

## **Seat Belts and Supplemental Restraint System (SRS)**

Your vehicle is equipped with seat belts for all seats, emergency tensioning retractors for the front seats, and a driver airbag and knee bolster.

### **Seat Belts Important!**

Laws in most states and all Canadian provinces require seat belt use.

All states and provinces require use of child restraints that complies with U.S. Federal Motor Vehicle Safety Standard 213 and Canadian Motor Vehicle Safety Standard 213.1. We strongly recommend their use.

### **Warning!**

**Never ride in a moving vehicle with the seat back reclined. Sitting in an excessively reclined position can be dangerous. You could slide under the seat belt in a collision. If you slide under it, the belt would apply force at the abdomen or neck. That could cause serious or even fatal injuries. The seat back and seat belts provide the best restraint when the wearer is in an upright position and belts are properly positioned on the body.**

### **Seat Belt Warning System**

With the key in steering lock position **2**, an audible warning sounds for a short time if the driver's seat belt is not fastened.

When someone enters the car (front) the reminder lamp, located below the front interior/reading lamp, flashes for a short time to remind all occupants to fasten seat belts.

### **Warning!**

**If you are ever in an accident, your injuries can be considerably more severe without your seat belt properly buckled. Without your seat belt buckled, you can hit the interior of the vehicle or be ejected from it. You can be seriously injured or killed.**

**In the same crash, the possibility for injury or death is lessened with your seat belt buckled.**

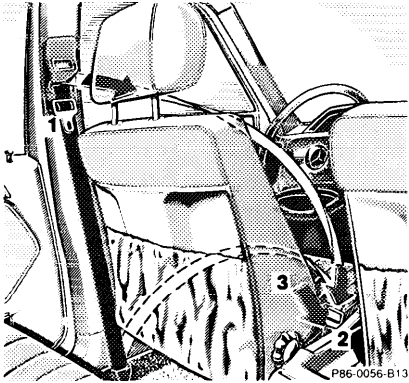

- 1 Latch plate
- 2 Buckle
- 3 Release button

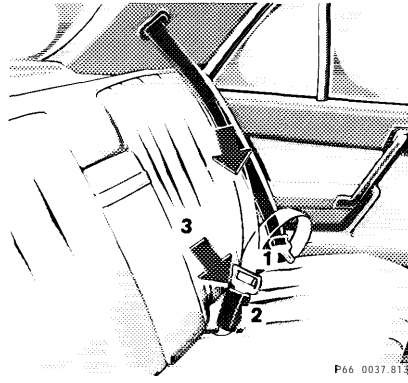

### Fastening of Seat Belts

Pull belt with latch plate (1) across shoulder and lap so that the lap belt is positioned as low as possible on your hips and not across the abdomen. Do not twist the belt. For safety reasons, avoid adjusting the seat or seat back into positions which could affect the correct seat belt position.

Push latch plate (1) into buckle (2) until it clicks.

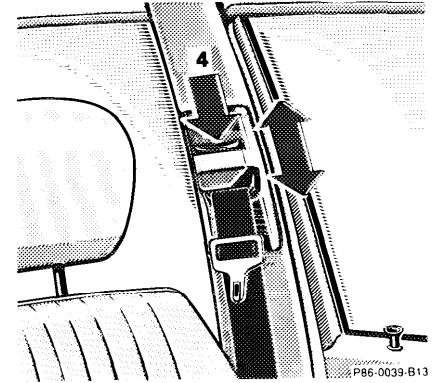

Adjust front seat belts so that the shoulder portion of the belt is located as close as possible to the middle of the shoulder (it should not touch the neck). For this purpose, raise or lower the belt outlet (3 positions). To lower the belt outlet, press button (4).

The shoulder portion of the seat belt must be pulled snug and checked for snugness immediately after engaging it and during driving. Tighten the lap portion to a snug fit by pulling shoulder portion up.

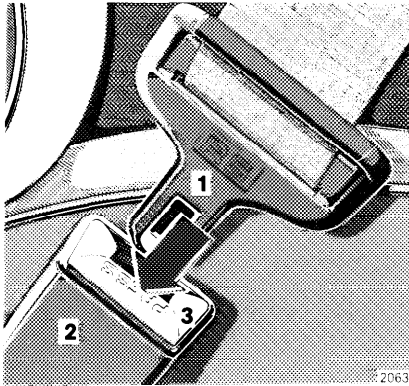

### Unfastening of Seat Belts

Push in the red button (3) in the belt buckle (2).

Allow the retractor to completely rewind the seat belt by guiding the latch plate (1).

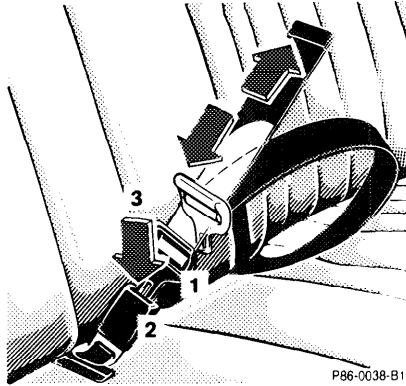

### Operation:

The inertia reel stops the belt from unwinding during sudden vehicle stops or when quickly pulling on the belt.

The locking function of the reel may be checked by quickly pulling out the belt.

The emergency tensioning retractors tighten the fastened front seat belts during frontal and front-angled impacts exceeding the first threshold of the SRS (see Index).

### Lap Belt for Center Seating Position of the Rear Seat

Pull belt with latch plate (1) over lap so that the belt is positioned as low as possible on your hips and not across the abdomen. Push latch plate (1) into buckle (2) until it clicks. Do not twist the belt but keep it tight.

To tighten the belt: With the latch plate engaged, pull the loose end of the belt.

To lengthen the belt: With the belt unfastened, turn the latch plate so that it is a little more than 90° perpendicular to the belt, then extend the belt. Fasten the belt and tighten as stated above.

To disengage the belt, push red button (3) in the buckle.

If the center seat is not occupied, the belt buckle and rolled-up seat belt can be stored in the space next to the rear arm rest (to the left or right of armrest).

### Note:

For cleaning and care of the seat belts, see Upholstery in Index.

**Warning!**

**USE SEAT BELTS PROPERLY.**

- Each occupant should wear their seat belt at all times. Together with the "SRS" (driver airbag, ETR's, driver – side knee bolster), the seat belt offers the best conditions for protection of the body in case of major frontal impact.
- Improperly positioned seat belts do not provide maximum protection and may cause serious injuries in case of an accident.
- Never wear the shoulder belt under your arm, against your neck or off your shoulder. In a crash, your body would move too far forward. That would increase the chance of head and neck injuries. The belt would also apply too much force to the ribs, which could severely injure internal organs such as your liver or spleen.

- Position the lap belt as low as possible on your hips and not across the abdomen. If the belt is positioned across your abdomen, it could cause serious injuries in a crash.
- Each seat belt should never be used for more than one person at a time. Do not fasten a seat belt around a person and objects.
- Belts should not be worn twisted. In a crash, you wouldn't have the full width of the belt to take impact forces. The twisted belt against your body could cause injuries.
- Pregnant women should also use a lap-shoulder belt. The lap belt portion should be positioned as low as possible on the hips to avoid any possible pressure on the abdomen.

**USE CHILD RESTRAINTS PROPERLY.**

- Infants and small children must be seated in an infant or child restraint system, which is properly secured by a lap belt or lap belt portion of a lap-shoulder belt. Children could be endangered in an accident if their child restraints are not properly secured in the vehicle.
- According to accident statistics, children are safer when properly restrained in the rear seating positions than in the front seating positions.
- Children too big for child restraint systems should ride in rear seats using regular seat belts. Position shoulder belt across chest and shoulder, not face or neck. A booster seat may be necessary to achieve proper belt positioning.

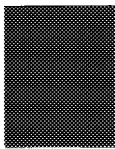

## **Supplemental Restraint System (SRS)**

The SRS uses two crash severity levels (thresholds) to activate either the ETR or airbag or both. Activation depends on the direction and severity of the impact, exceeding the thresholds and fastening of the seat belt.

Seat belt fastened

- first threshold exceeded: ETR activates
- second threshold exceeded: airbag also activates

Seat belt not fastened

- first threshold exceeded: airbag activates, but not ETR

Driver and front passenger systems operate independently from each other.

## **Emergency Tensioning Retractor (ETR)**

The seat belts for the front seats are equipped with emergency tensioning retractors. These tensioning retractors are located in each belt's inertia reel and become operationally ready with the key in steering lock position 1 or 2.

The emergency tensioning retractors are designed to activate only when the seat belts are fastened during frontal and front-angled impacts exceeding the first threshold of the SRS. They remove slack from the belts in such a way that the seat belts fit more snugly against the body restricting its forward movement as much as possible.

In cases of other frontal impacts, roll-overs, certain side impacts, rear collisions, or other accidents without frontal forces, the emergency tensioning retractors will not be activated. The driver and passengers will then be protected by the fastened seat belts and inertia reel in the usual manner.

For seat belt and emergency tensioning retractor safety guidelines see *Safety Guidelines* in Index.

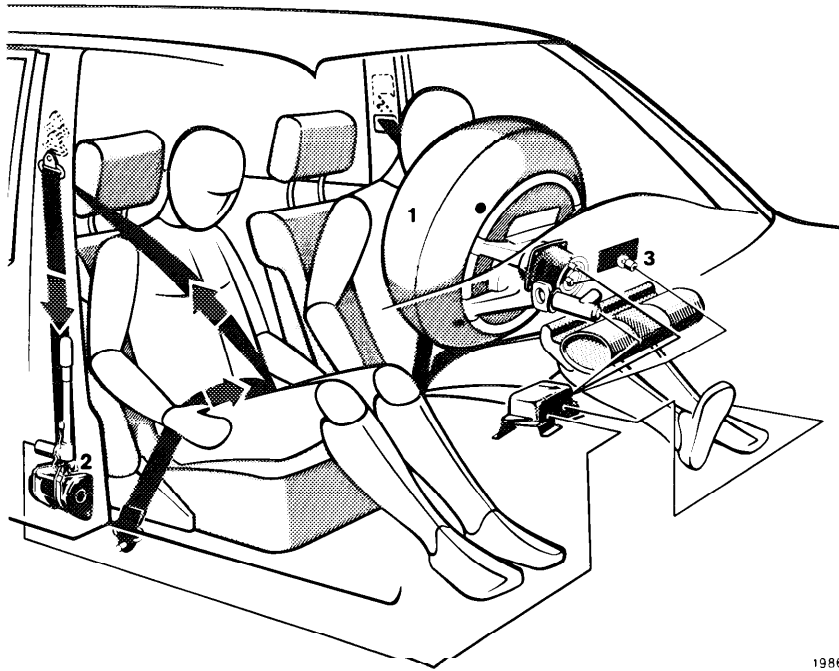

## Driver Airbag

The most effective occupant restraint system yet developed for use in production vehicles is the seat belt. In some cases, however, the protective effect of seat belts can be further enhanced by an airbag.

The driver airbag (1) is located in the steering wheel hub and, in conjunction with wearing the seat belts with emergency tensioning retractors (2), provides increased protection for the driver.

The operational readiness of the airbag system is verified by the indicator lamp "SRS" (3) in the instrument cluster. If no fault is detected, the lamp will go out after approximately 4 seconds; after the lamp goes out, the system continues to monitor the components and circuitry of the airbag system and will indicate a malfunction by coming on again.

1986

The following system components are monitored or undergo a self-check: crash-sensor, airbag ignition circuit, driver and front passenger seat belt buckles. Initially, when the key is turned from steering lock position 0 to positions 1 or 2, malfunctions in the crash-sensor are detected and indicated (the "SRS" indicator lamp stays on longer than 4 seconds).

In the operational mode, after the indicator lamp has gone out following the initial check, interruptions and short circuits in the airbag ignition circuit and in the driver and front passenger seat belt buckle harnesses, and low voltage in the entire system are detected and indicated.

In the event a malfunction of the "SRS" is indicated as outlined above, the "SRS" may not be operational. We strongly recommend that you visit an authorized Mercedes-Benz dealer immediately to have the system checked; otherwise the "SRS" may not be activated when needed.

### **Important!**

**The airbag is designed to activate only in certain frontal and front-angled impacts. Only during these types of impacts will it provide its supplemental protection. The driver should always wear the seat belt, otherwise it is not possible for the airbag to provide its intended protection.**

**In cases of other frontal impacts, roll-overs, certain side impacts, rear collisions, or other accidents without frontal forces, the airbag will not be activated. The driver and passengers will then be protected by the fastened seat belts.**



### **Important!**

The “SRS” is designed to reduce the potential of injury in certain frontal and front-angled impacts which may cause injuries, however, no system available today can totally eliminate injuries and fatalities.

The activation of the “SRS” temporarily releases a small amount of dust from the airbag. This dust, however, is neither injurious to your health, nor does it indicate a fire in the vehicle.

The service life of the airbag extends to the date indicated on the label located on the driver-side door latch post. To provide continued reliability after that date, it should be inspected by an authorized Mercedes-Benz dealer at that time and replaced when necessary.

### **Warning!**

It is very important for your safety to be in a properly seated position and to wear your seat belt.

For maximum protection in the event of a collision always be in a normal seated position with your back against the seat back. Fasten your seat belt and ensure that it is properly positioned on the body.

Since the airbag inflates with considerable speed and force, a proper seating position will keep you a safe distance from the airbag:

- Sit properly belted in an upright position with your back against the seat back.

- Do not lean with your head or chest close to the steering wheel or dashboard.
- Adjust the passenger seat as far as possible rearward from the dashboard, especially if a child restraint is installed.
- Infants and small children should only be seated in a rear seat and be properly secured in a child restraint system.

Failure to follow these instructions can result in severe injuries to you or other occupants.

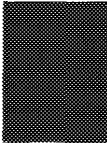

## Safety Guidelines for the Seat Belt, Emergency Tensioning Retractor and Airbag

### Warning!

- Damaged belts or belts that were highly stressed in an accident must be replaced and their anchoring points must also be checked. Use only belts installed or supplied by an authorized Mercedes-Benz dealer.
- Do not pass belts over sharp edges.
- Do not make any modification that could change the effectiveness of the belts.
- The “SRS” is designed to function on a one-time only basis. An airbag or emergency tensioning retractor (ETR) that was activated must be replaced.

- No modifications of any kind may be made to any components or wiring of the “SRS”. This includes the installation of additional trim material, badges etc. over the steering wheel hub and installation of additional electrical/electronic equipment on or near “SRS” components and wiring.
- Several airbag system components at the steering wheel get hot after the airbag has inflated. Don't try to touch them.
- Improper work on the system, including incorrect installation and removal, can lead to possible injury through an uncontrolled activation of the “SRS”.

- In addition, through improper work there is the risk of rendering the “SRS” inoperative. Work on the “SRS” must therefore only be performed by an authorized Mercedes-Benz dealer.
- When scrapping the airbag unit or emergency tensioning retractor, it is mandatory to follow our safety instructions. These instructions are available at your authorized Mercedes-Benz dealer.

When you sell the vehicle we strongly urge you to give notice to the subsequent owner that it is equipped with an “SRS” by alerting him to the applicable section in the Owner's Manual.

## Infant and Child Restraint Systems

We recommend that all infants and children be restrained at all times while the vehicle is in motion.

### Important!

The use of infant or child restraints is required by law in all 50 states and all Canadian provinces.

Infants and small children should be seated in an infant or child restraint system, which is properly secured by the lap belt or lap belt portion of a lap-shoulder belt, and that complies with U.S. Federal Motor Vehicle Safety Standard 213 and Canadian Motor Vehicle Safety Standard 213.1. A statement by the child restraint manufacturer of compliance with this standard can be found on the instruction label on the restraint and in the instruction manual provided with the restraint.

When using any infant or child restraint system, be sure to carefully read and follow all manufacturer's instructions for installation and use.

### Warning!

**According to accident statistics, children are safer when properly restrained in the rear seating positions than in the front seating positions.**

**Infants and small children should never be held on the lap while the vehicle is in motion. During an accident they would be almost impossible to hold, and could be crushed between the adult and the dashboard.**

**Infants and small children should never share a seat belt with another occupant. During an accident, they could be crushed between the occupant and seat belt.**

**Children too big for child restraint systems should ride in rear seats using regular seat belts. Position shoulder belt across chest and shoulder, not face or neck. A booster seat may be necessary to achieve proper belt positioning.**

**When the child restraint is not in use, remove it from the car or secure it with the seat belt to prevent the child restraint from becoming a projectile in the event of an accident.**

U.S.A. Models only

Since 1986 all U.S. child restraints comply with U.S. regulations without the use of a tether strap.

Canada Models only:

This vehicle can be equipped with tether anchorages for a top tether strap. Consult your authorized Mercedes-Benz dealer for installation of these anchorages.

In compliance with Canadian Motor Vehicle Safety Standard 210.1, child restraint tether anchorage hardware is attached to the tool kit located in the trunk.

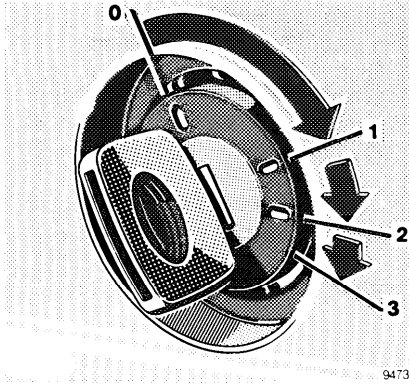

### Steering Lock

**0** The key can be withdrawn in this position only. The steering is locked with the key removed from the steering lock.

In models equipped with automatic transmission, the key can be removed only with the selector lever in position "P". After removing the key or with the key in steering lock position 0, the selector lever is locked in position "P".

#### Warning!

**Models with manual transmission: Do not remove key from the steering lock while the vehicle is in motion as this will cause the engagement of the steering lock thus rendering the vehicle impossible to steer.**



- 1 Steering is unlocked.  
(If necessary, move steering wheel slightly to allow the key to be turned clockwise to position 1.)
- 2 Driving position.
- 3 Starting position.  
Refer to *Index* for *Starting and turning off* the engine.

#### Warning!

**When leaving the vehicle always remove the key from the steering lock. Do not leave children unattended in the vehicle. Unsupervised use of vehicle equipment may cause serious personal injury.**

Notes:

The following items can be operated with the key in steering lock position 1:

Wiper,  
windshield washer system,  
headlamp cleaning system  
(only in exterior lamp switch  
positions  or )  
headlamp flasher,  
lighter,  
glove box lamp,  
sliding roof,  
rear window defroster,  
power windows,  
power seats.

An audible warning will sound when the driver's door is opened with the key in steering lock position 1 or 0.

With the engine at idle speed, the charging rate of the alternator (output) is limited.

It is therefore recommended to turn off unnecessary electrical consumers while driving in stop-and-go traffic. This precaution helps to avoid draining of the battery.

Unnecessary strain on the battery and charging system may be minimized by turning off the following power consumers, for example: Heated seats, rear window defroster.

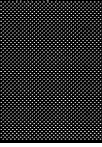

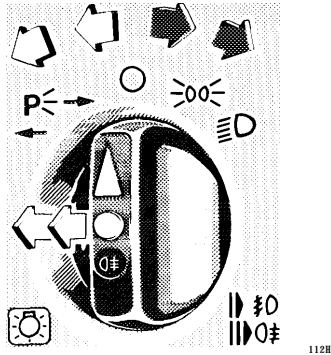

### Exterior Lamp Switch ( )

Canada only:

When the engine is running, the low beam (includes parking lamps, side marker lamps, taillamps, license plate lamps and instrument panel lamps) are automatically switched on.

Note:

For nighttime driving the exterior lamp switch should be turned to position  to permit activation of the high beam headlamps.



Off

Parking lamps (includes side marker lamps, tail-lamps, license plate lamps, instrument panel lamps)

Canada only:  
When the engine is running, the low beam is additionally switched on.



Parking lamps plus low beam or high beam headlamps (combination switch pushed forward)



Standing lamps, right  
(turn left one stop)



Standing lamps, left  
(turn left two stops)



Fog lamps  
(pull out one stop) with parking and/or headlamps on



Rear fog lamp  
(pull out to 2nd detent)  
In addition to fog lamps. Indicator lamp in lamp switch comes on.

### Standing Lamps

When the vehicle is parked on the street the standing lamps (right or left side parking lamps) can be turned on, making the vehicle more visible to passing vehicles.

The standing lamps can only be operated with the key in steering lock position 0 or 1.

Notes:

With the key removed and the driver's door open, an audible warning will sound if the vehicle's exterior lamps (except standing lamps) are not switched off.

Fog lamps will operate together with the parking lamps and the low or high beam headlamps. Fog lamps should only be used in conjunction with low beam headlamps. Consult your state Motor Vehicle Regulations regarding allowable lamp operation.

Fog lamps are automatically switched off when the exterior lamp switch is turned to position .

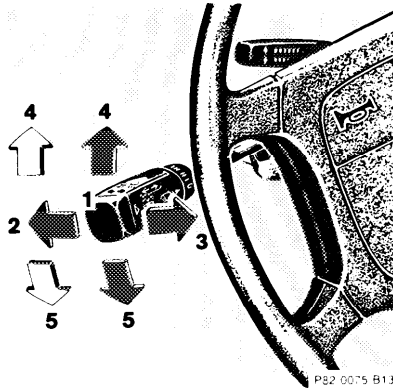

P82 0075 B13

### Combination Switch

- 1 Low beam (with exterior lamp switch turned to position  $\equiv D$ )
- 2 High beam (with exterior lamp switch turned to position  $\equiv D$ )
- 3 High beam flasher (high beam available independent of exterior lamp switch position)
- 4 Turn signals, right
- 5 Turn signals, left

To operate the turn signals, move the combination switch past the point of resistance (up or down). The switch is automatically canceled when the steering wheel is turned to a large enough degree.

To signal minor directional changes, such as changing lanes on a highway, move combination switch to the point of resistance only and hold it there.

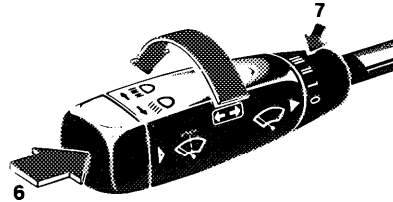

P82 0073 B13

### 6 Control for

- windshield washer system
  - headlamp cleaning system (will work only with exterior lamp switch in position  $\equiv D$  or  $\equiv D$ ).
- Canada only:  
Also in position  $\bigcirc$  when the engine is running)

When the washer system is activated, the wiper also operates for a limited time.

The windshield washer nozzles are automatically heated.

### 7 Windshield wiper control

- 0 Wiper off
- I Intermittent wiping
- II Normal wiper speed
- III Fast wiper speed

Note:

If one of the turn signals fails, the turn signal indicator system flashes and sounds at a faster rate than normal.

If the windshield wiper smears the windshield, even during rain, activate the washer system as often as necessary. The fluid in the washer reservoir should be mixed in the correct ratio.

### Windshield Washer Fluid Mixing Ratio

For temperatures above freezing:

MB Windshield Washer Concentrate "S" and water

1 part "S" to 100 parts water  
(40 ml "S" to 1 gallon water).

For temperatures below freezing:

MB Windshield Washer Concentrate "S" and commercially available premixed windshield washer solvent/antifreeze

1 part "S" to 100 parts solvent  
(40 ml "S" to 1 gallon solvent).

### Shelf below Rear Window

#### Warning!

The shelf below the rear window should not be used to carry objects. This will prevent such objects from being thrown about and injuring vehicle occupants during an accident or sudden maneuver.

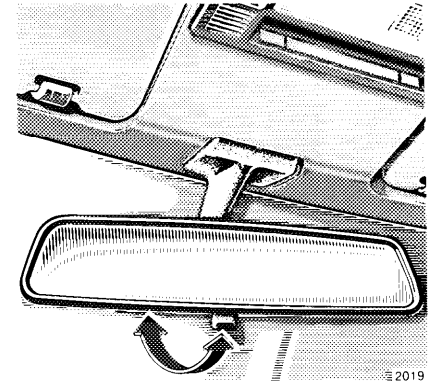

### Inside Rear View Mirror

The mirror can be tilted to the anti-glare night position using the lever at its lower edge.

Use your inside mirror to determine the size and distance of objects seen in the passenger-side convex mirror.



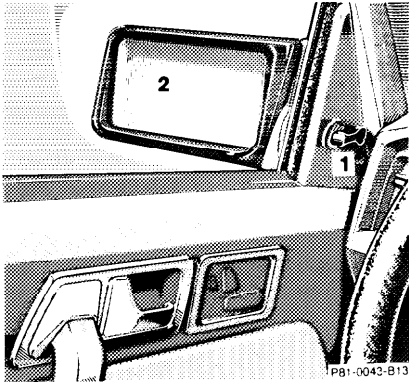

### Exterior Rear View Mirrors

- 1 Adjusting lever
- 2 Exterior mirror

The exterior mirrors have electrically heated glass. The heater switches on automatically, depending on outside temperature.

Driver's side:

The exterior mirror (2) can be adjusted from inside the vehicle by moving adjusting lever (1) in the desired direction.

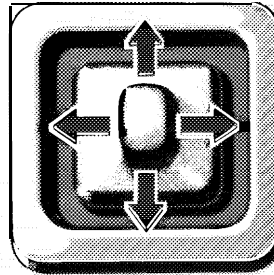

### Warning!

Exercise care when using the passenger-side mirror. The passenger-side exterior mirror is convex (outwardly curved surface for a wider field of view). Objects in mirror are closer than they appear. Check your inside rear view mirror or glance over your shoulder before changing lanes.

Note:

If the mirror housing is forcibly pivoted from its normal position, it must be repositioned by applying firm pressure until it snaps into place.

Passenger-side:

The passenger-side exterior mirror is convex (outwardly curved surface for a wider field of view).

To adjust the mirror:

Turn key in steering lock to position 2. The exterior mirror can be adjusted using the switch located in the center console.\* Adjust the mirror so you can just see the side of your vehicle in the portion of the mirror closest to the car.

9266

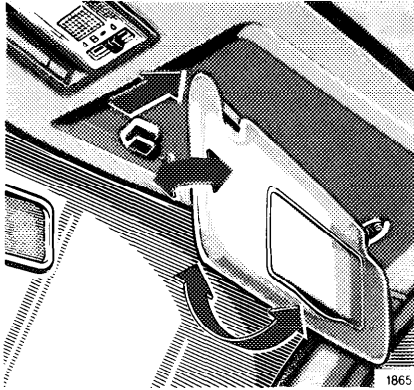

### Sun Visors

Swing sun visors down to protect against sun glare.

If sunlight enters through the side window, disengage visor from inner mounting and pivot to the side.

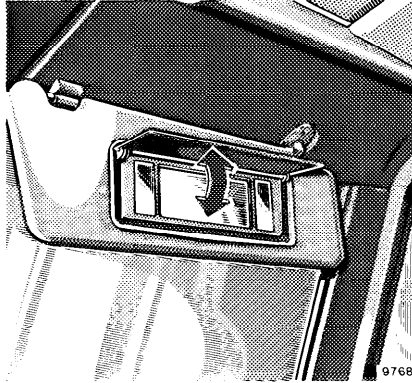

### Vanity mirror:

With the visor engaged in its inner mounting, the lamp can be switched on by opening the cover.

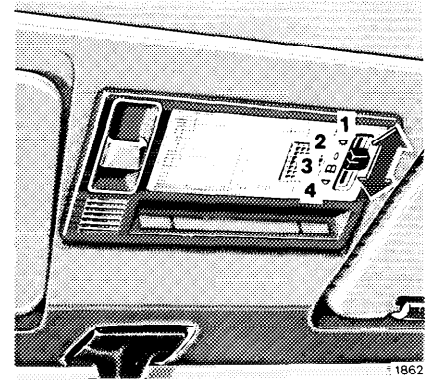

### Interior Lamps

The switch for the front lamp (combination interior and reading lamp) has 4 positions.

- 1 Interior and reading lamp switched on continuously.
- 2 Interior and reading lamp switched off.
- 3 Reading lamp switched on continuously.
- 4 Interior lamp is switched on, and off delayed, by the front door contact switches. However, there will be no delay when the key is in steering lock position 2.

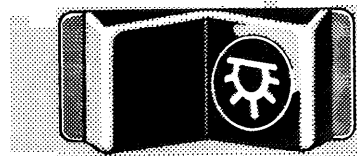

9715

The rear courtesy lamp is switched on and off by the rear door contact switches or by the rocker switch on the left side of the instrument panel.

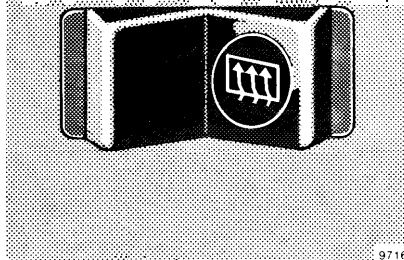

9716

#### Rear Window Defroster

With engine running, press symbol side of rocker switch to turn on, press left side to turn off.

When activating the rear window defroster, the indicator lamp in the switch will come on.

#### Note:

The rear window defroster uses a large amount of power. To keep the battery drain to a minimum, turn off the defroster as soon as the window is clear. The defroster is automatically turned off after a maximum of 20 minutes of operation. Heavy accumulation of snow and ice should be removed before activating the defroster.

If several power consumers are turned on simultaneously, or the battery is only partially charged, it is possible that the defroster will automatically turn itself off. When this happens, the indicator lamp inside the switch starts blinking. As soon as the battery has sufficient voltage, the defroster automatically turns itself back on.

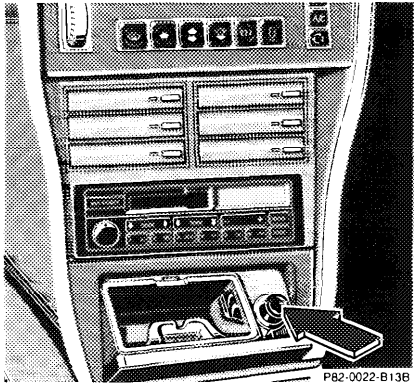

### Lighter

Turn key in steering lock to position 1 or 2.

Touch the ashtray lid. The ashtray opens automatically.

Push in lighter; it will pop out automatically when hot.

#### **Warning!**

**Never touch the heating element or sides of lighter, hold at knob only.**

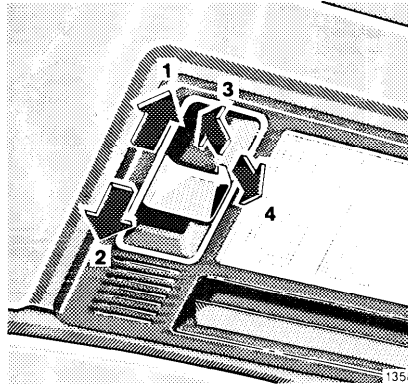

### Sliding Roof with Rear Pop-Up Feature

Turn key in steering lock to position 1 or 2. Activate switch.

1 to slide roof open

2 to slide roof closed

3 to raise roof at rear

4 to lower roof at rear

The switch is illuminated when the exterior lamps are switched on (except standing lamps).

The sliding roof can be opened or closed manually should an electrical malfunction occur, refer to Emergency Operation in Index.

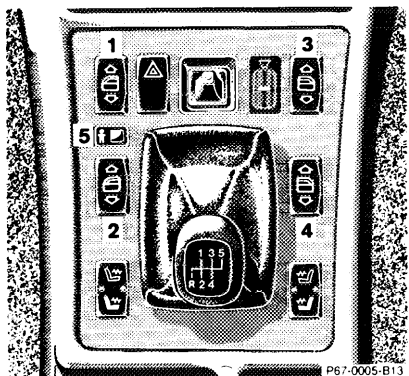

### Power Windows

Switch group for power windows:

- 1 left, front
- 2 left, rear
- 3 right, front
- 4 right, rear
- 5 safety switch
- 6 individual switches (rear doors)

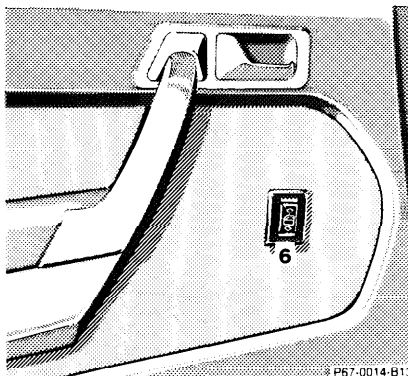

**Warning!**  
When leaving the vehicle, always remove the key from the steering lock. Do not leave children unattended in the vehicle. Unsupervised use of vehicle equipment can cause serious personal injury.

The power windows can only be operated with the key in steering lock position 1 or 2.

All four windows can then be operated using the switches in the center console. The rear door windows can also be operated using the switches (6) in each rear door panel. If inadvertent operation of the rear windows by switch (6) (for instance by children) is to be prevented, push safety switch (5) to the right (symbol becomes visible).

### **Antenna**

The antenna extends when switching on the radio and/or telephone.

Note:

To retract the antenna (e.g. when entering a car wash) both radio and telephone must be switched off.

### **Cellular Telephone**

The vehicle is prepared for the installation of a cellular telephone. For further information and installation contact your authorized Mercedes-Benz dealer.

#### **Warning!**

**Some jurisdictions prohibit the driver from using a cellular telephone while driving a vehicle. Therefore, for safety reasons, the driver should not use the cellular telephone while the vehicle is in motion. Stop the vehicle in a safe location before answering or placing a call.**