

IEEE Standard Definitions of Terms for Antennas

Sponsor

**Antenna Standards Committee
of the
IEEE Antennas and Propagation Society**

Approved March 18, 1993

IEEE Standards Board

Abstract: Definitions of terms in the field of antennas are provided.

Keywords: antennas, definitions, propagation, terminology

The Institute of Electrical and Electronics Engineers, Inc.
345 East 47th Street, New York, NY 10017-2394, USA

Copyright © 1993 by the Institute of Electrical and Electronics Engineers, Inc.
All rights reserved. Published 1993. Printed in the United States of America

ISBN 1-55937-317-2

No part of this publication may be reproduced in any form, in an electronic retrieval system or otherwise, without the prior written permission of the publisher.

IEEE Standards documents are developed within the Technical Committees of the IEEE Societies and the Standards Coordinating Committees of the IEEE Standards Board. Members of the committees serve voluntarily and without compensation. They are not necessarily members of the Institute. The standards developed within IEEE represent a consensus of the broad expertise on the subject within the Institute as well as those activities outside of IEEE that have expressed an interest in participating in the development of the standard.

Use of an IEEE Standard is wholly voluntary. The existence of an IEEE Standard does not imply that there are no other ways to produce, test, measure, purchase, market, or provide other goods and services related to the scope of the IEEE Standard. Furthermore, the viewpoint expressed at the time a standard is approved and issued is subject to change brought about through developments in the state of the art and comments received from users of the standard. Every IEEE Standard is subjected to review at least every five years for revision or reaffirmation. When a document is more than five years old and has not been reaffirmed, it is reasonable to conclude that its contents, although still of some value, do not wholly reflect the present state of the art. Users are cautioned to check to determine that they have the latest edition of any IEEE Standard.

Comments for revision of IEEE Standards are welcome from any interested party, regardless of membership affiliation with IEEE. Suggestions for changes in documents should be in the form of a proposed change of text, together with appropriate supporting comments.

Interpretations: Occasionally questions may arise regarding the meaning of portions of standards as they relate to specific applications. When the need for interpretations is brought to the attention of IEEE, the Institute will initiate action to prepare appropriate responses. Since IEEE Standards represent a consensus of all concerned interests, it is important to ensure that any interpretation has also received the concurrence of a balance of interests. For this reason IEEE and the members of its technical committees are not able to provide an instant response to interpretation requests except in those cases where the matter has previously received formal consideration.

Comments on standards and requests for interpretations should be addressed to:

Secretary, IEEE Standards Board
445 Hoes Lane
P.O. Box 1331
Piscataway, NJ 08855-1331
USA

IEEE Standards documents are adopted by the Institute of Electrical and Electronics Engineers without regard to whether their adoption may involve patents on articles, materials, or processes. Such adoption does not assume any liability to any patent owner, nor does it assume any obligation whatever to parties adopting the standards documents.

Introduction

(This introduction is not a part of IEEE Std 145-1993, IEEE Standard Definitions of Terms for Antennas.)

This document is a revision of IEEE Std 145-1983, IEEE Standard Definitions of Terms for Antennas, and corrects minor errors that appeared in that printing. The original standard was issued in 1969.

The following persons were on the working group that developed this document:

Donald G. Bodnar, *Chair*

Charles C. Allen	Edward Joy	Antoine G. Roederer
A. David Bresler	Walter K. Kahn	Allen C. Schell
Richard H. Bryan	Flemming H. Larsen	Alan J. Simmons
Robert B. Dybdal	Richard B. Mack	G. P. Tricoles
William J. English	Allen C. Newell	Michael T. Tuley
E. S. Gillespie	H. George Oltman	Edward A. Urbanik
Edward Hart	A. David Olver	A. T. Villeneuve
Doren Hess	Harold R. Raemer	Jonathan D. Young

The following persons were on the balloting committee that approved this document for submission to the IEEE Standards Board:

Charles C. Allen	Doren Hess	Antoine G. Roederer
Donald G. Bodnar	Edward Joy	Allen C. Schell
A. David Bresler	Walter K. Kahn	Alan J. Simmons
Richard H. Bryan	Flemming H. Larsen	G. P. Tricoles
Robert B. Dybdal	Richard B. Mack	Michael T. Tuley
William J. English	Allen C. Newell	Edward A. Urbanik
E. S. Gillespie	H. George Oltman	A. T. Villeneuve
Edward Hart	A. David Olver	Jonathan D. Young
	Harold R. Raemer	

When the IEEE Standards Board approved this standard on March 18, 1993 it had the following membership:

Wallace S. Read, *Chair*

Donald C. Loughry, *Vice Chair*

Andrew G. Salem, *Secretary*

Gilles A. Baril	Ben C. Johnson	Don T. Michael*
Clyde R. Camp	Walter J. Karplus	Marco W. Migliaro
Donald C. Fleckenstein	Lorraine C. Kevra	L. John Rankine
Jay Forster*	E. G. "Al" Kiener	Arthur K. Reilly
David F. Franklin	Ivor N. Knight	Ronald H. Reimer
Ramiro Garcia	Joseph Koepfinger*	Gary S. Robinson
Donald N. Heirman	D. N. "Jim" Logothetis	Leonard L. Tripp
Jim Isaak		Donald W. Zipse

*Member Emeritus

Also included are the following nonvoting IEEE Standards Board liaisons:

Satish K. Aggarwal
James Beall
Richard B. Engelman
David E. Soffrin
Stanley I. Warshaw

Christopher J. Booth
IEEE Standards Project Editor

Contents

CLAUSE	PAGE
1. Overview.....	1
1.1 Scope.....	1
1.2 Background.....	1
1.3 Reference	3
1.4 Definition structure.....	3
2. Definitions.....	3

IEEE Standard Definitions of Terms for Antennas

1. Overview

1.1 Scope

It is assumed in this standard that an antenna is a passive linear reciprocal device. Thus, where a definition implies the use of an antenna in a transmitting situation, its use in a receiving situation is also implicit, unless specifically stated otherwise.

When an antenna or group of antennas is combined with circuit elements that are active, nonlinear, or nonreciprocal, the combination is regarded as a system that includes an antenna. Examples of such cases are an adaptive antenna system and a signal-processing antenna system; the complete conical-scanning, monopulse, and compound interferometer systems also fall in this category.

For terms that are quantitative, it is understood that frequency must be specified. For those in which phase or polarization is a significant part of the definition, a coherent source of power is implied. Whenever a term is commonly used in other fields but has specialized significance in the field of antennas, this is noted in the title.

When applying terms pertaining to radiation characteristics, such as gain, polarization, beamwidth, etc., to multiple-beam antennas, each port shall be considered to be that of a separate antenna with a single main beam. For polarization diversity systems that may include active devices, these terms apply to each polarization state for which the antenna is adjusted.

Throughout this standard, where phasors are used, or are implied, the time convention shall be taken to be $\exp(j\omega t)$.

1.2 Background

The definitions of terms contained herein, for the most part, stand alone and are easily understood out of context. The terms pertaining to gain, directivity and polarization, however, are interrelated and hence require some elaboration.

The viewpoint taken for polarization is that this term can be used in three related meanings. It can apply

- a) To a field vector at some point in space
- b) To a plane wave
- c) To an antenna

The *polarization of a field vector* specifies the shape, orientation, and sense of the ellipse that the extremity of the field vector describes as a function of time. This applies to any field vector: electric field, magnetic field, velocity field in a plasma, displacement field in a solid, etc. In a single-frequency plane wave, a specified field vector has the same polarization at every point in space. This is taken as the *polarization of the plane wave*. Conventionally, in electromagnetics, the electric field is considered rather than the magnetic field. However, in a nonisotropic medium, the polarization state of the plane wave requires consideration of all its vector components. The third application of the term *polarization* is to antennas. The *polarization of*

an antenna in a given direction is that of the plane wave it radiates at large distances in that direction. By reciprocity, a plane wave coming from that direction whose polarization ellipse has the same axial ratio, orientation, and sense will yield the maximum response for a given power flux density. For best understanding, the three related definitions of polarization should be read in the above order.

One departure from previous usage should be noted. The definition of the tilt angle of the polarization ellipse now requires that it be measured according to the right-hand rule with the thumb pointing in a reference direction. For a plane wave, the reference direction is the direction of propagation. This is advantageous, since it removes any ambiguity about the specification of the orientation of the polarization ellipse. It should be noted, however, that the polarization of the antenna is defined as that of the wave it radiates, whether it is used for transmitting or receiving. This means that for the receive case, the coordinate system used to describe the polarization of the antenna and the incoming wave are oriented in opposite directions. (See IEEE Std 149-1979, IEEE Standard Test Procedures for Antennas, clause 11, Polarization.¹) There are two ways to handle this situation. One is to transform the polarization of the wave into the antenna's coordinate system; the second is to define a *receiving polarization* for the antenna, which is that of the wave to which the antenna is polarization matched. The latter was chosen both here and in IEEE Std 149-1979. This should not be taken to mean that one cannot use the antenna's coordinate system, but rather that if it is done, it should be clearly specified as the polarization of the incoming wave referred to the antenna's (transmitting) polarization. The term *receiving polarization* can also be applied to a nonreciprocal antenna that may receive only.

The interdependence of gain, polarization, and impedance has led to the inclusion of several terms, including *partial gain*, *partial directivity*, and *partial realized gain*. The interrelationships of these terms and the basic terms *gain*, *directivity* and *realized gain* are best visualized by referring to the flow chart shown in figure 1. A similar flow chart can be constructed for a receiving antenna.

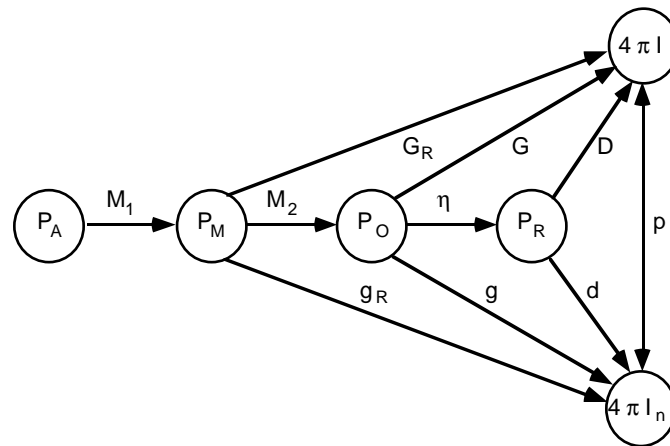

- | | |
|--------------------------------------------------|-------------------------------|
| P_A = power available from the generator | η = radiation efficiency |
| P_M = power to matched transmission line | G_R = realized gain |
| P_O = power accepted by the antenna | G = gain |
| P_R = power radiated by the antenna | D = directivity |
| I = radiation intensity | g_R = partial realized gain |
| I_n = partial radiation intensity [†] | g = partial gain |
| M_1 = impedance mismatch factor 1 | d = partial directivity |
| M_2 = impedance mismatch factor 2 | p = polarization efficiency |

Figure 1—Gain and directivity flow chart

[†]Information on the reference can be found in 1.3.

1.3 Reference

This standard shall be used in conjunction with the following publication:

IEEE Std 149-1979 (Reaff 1990), IEEE Standard Test Procedures for Antennas (ANSI).²

1.4 Definition structure

In these definitions, words or phrases in parentheses that are part of the term can be omitted when the term is used, provided they are understood from context. Those words or phrases in brackets can replace the words or phrases that immediately precede them. If bracketed words or phrases appear in several places in the definition, then all bracketed words or phrases must be used together in the definitions. For those cases where two or more terms are synonyms, the preferred term will be defined; the other terms will refer to the preferred term and be listed after the definition. Abbreviations appear after the term and are enclosed in parentheses. Terms that are no longer recommended for use are indicated as being deprecated. Synonyms for a term are listed at the end of the definition.

2. Definitions

2.1 absolute gain (of an antenna). *See: gain (in a given direction).*

2.2 active array antenna system. An array in which all or part of the elements are equipped with their own transmitter or receiver, or both.

NOTES

1—Ideally, for the transmitting case, amplitudes and phases of the output signals of the various transmitters are controllable and can be coordinated in order to provide the desired aperture distribution.

2—Often it is only a stage of amplification or frequency conversion that is actually located at the array elements, with the other stages of the receiver or transmitter remotely located.

2.3 active impedance (of an array element). The ratio of the voltage across the terminals of an array element to the current flowing at those terminals when all array elements are in place and excited.

2.4 active reflection coefficient (of an array element). The reflection coefficient at the terminals of an array element when all array elements are in place and excited.

2.5 adaptive antenna system. An antenna system having circuit elements associated with its radiating elements such that one or more of the antenna properties are controlled by the received signal.

2.6 Adcock antenna. A pair of vertical antennas separated by a distance of one-half wavelength or less, and connected in phase opposition to produce a radiation pattern having the shape of the figure eight in all planes containing the centers of the two antennas.

2.7 aerial. [Deprecated.]

2.8 Alford loop antenna. A multi-element antenna having approximately equal amplitude currents that are in phase and uniformly distributed along each of its peripheral elements and producing a substantially circular radiation pattern in its principal E-plane.

²IEEE publications are available from the Institute of Electrical and Electronics Engineers, Service Center, 445 Hoes Lane, P.O. Box 1331, Piscataway, NJ 08855-1331, USA.

NOTE—This antenna was originally developed as a four-element, horizontally polarized, UHF loop antenna.

2.9 amplitude pattern. *See: radiation pattern.*

2.10 angle tracking. *See: tracking.*

2.11 annular slot antenna. A slot antenna with the radiating slot having the shape of an annulus.

2.12 antenna. That part of a transmitting or receiving system that is designed to radiate or to receive electromagnetic waves.

2.13 antenna array. *See: array antenna.*

2.14 antenna effect. [Deprecated.]

2.15 antenna efficiency of an aperture-type antenna. For an antenna with a specified planar aperture, the ratio of the maximum effective area of the antenna to the aperture area.

2.16 antenna [aperture] illumination efficiency. The ratio, usually expressed in percent, of the maximum directivity of an antenna [aperture] to its standard directivity. *Syn: normalized directivity.* *See: standard [reference] directivity.*

NOTE—For planar apertures, the standard directivity is calculated by using the projected area of the actual antenna in a plane transverse to the direction of its maximum radiation intensity.

2.17 antenna pattern. *See: radiation pattern.*

2.18 antenna resistance. The real part of the input impedance of an antenna.

2.19 aperiodic antenna. An antenna that, over an extended frequency range, does not exhibit a cyclic behavior with frequency of either its input impedance or its pattern.

NOTE—This term is often applied to an electrically small monopole or loop, containing an active element as an integral component, with impedance and pattern characteristics varying but slowly over the extended frequency range.

2.20 aperture (of an antenna). A surface, near or on an antenna, on which it is convenient to make assumptions regarding the field values for the purpose of computing fields at external points.

NOTE—The aperture is often taken as that portion of a plane surface near the antenna, perpendicular to the direction of maximum radiation, through which the major part of the radiation passes.

2.21 aperture blockage. A condition resulting from objects lying in the path of rays arriving at or departing from the aperture of an antenna.

NOTE—For example, the feed, subreflector, or support structure produce aperture blockage for a symmetric reflector antenna.

2.22 aperture distribution. The field over the aperture as described by amplitude, phase, and polarization distributions. *Syn: aperture illumination.*

2.23 aperture illumination. *See: aperture distribution.*

2.24 aperture illumination efficiency. *See: antenna illumination efficiency.*

2.25 area. *See:* **effective area (of an antenna); equivalent flat plate area of a scattering object; partial effective area (of an antenna, for a given polarization and direction).**

2.26 areal beamwidth. For pencil-beam antennas the product of the two principal half-power beamwidths. *See:* **principal half-power beamwidths.**

2.27 array antenna. An antenna comprised of a number of identical radiating elements in a regular arrangement and excited to obtain a prescribed radiation pattern. *Syn:* **antenna array.**

NOTES

1—The regular arrangements possible include ones in which the elements can be made congruent by simple translation or rotation.

2—This term is sometimes applied to cases where the elements are not identical or arranged in a regular fashion. For those cases qualifiers shall be added to distinguish from the usage implied in this definition. For example, if the elements are randomly located, one may use the term **random array antenna.**

2.28 array element. In an array antenna, a single radiating element or a convenient grouping of radiating elements that have fixed relative excitations.

2.29 array factor. The radiation pattern of an array antenna when each array element is considered to radiate isotropically.

NOTE—When the radiation patterns of individual array elements are identical, and the array elements are congruent under translation, then the product of the array factor and the element radiation pattern gives the radiation pattern of the entire array.

2.30 artificial dielectric. A medium containing a distribution of scatterers, usually metallic, that react as a dielectric to radio waves.

NOTES

1—The scatterers are usually small compared to a wavelength and embedded in a dielectric material whose effective permittivity and density are intrinsically low.

2—The scatterers may be in either a regular arrangement or a random distribution.

2.31 axial ratio (of a polarization ellipse). The ratio of the major to minor axes of a polarization ellipse.

NOTE—The axial ratio sometimes carries a sign that is taken as plus if the sense of polarization is right-handed and minus if it is left-handed. *See:* **sense of polarization.**

2.32 axial ratio pattern. A graphical representation of the axial ratio of a wave radiated by an antenna over a radiation pattern cut.

2.33 backfire antenna. An antenna consisting of a radiating feed, a reflector element, and a reflecting surface such that the antenna functions as an open resonator, with radiation from the open end of the resonator.

2.34 back lobe. A radiation lobe whose axis makes an angle of approximately 180 degrees with respect to the beam axis of an antenna.

NOTE—By extension, a radiation lobe in the half-space opposed to the direction of peak directivity.

2.35 back-scattering cross section. *See:* **monostatic cross section.**

2.36 bandwidth of an antenna. The range of frequencies within which the performance of the antenna, with respect to some characteristic, conforms to a specified standard.

2.37 Bayliss distribution, circular. A continuous distribution over a circular planar aperture that yields a difference pattern with a sidelobe structure similar to that of a sum pattern produced by a Taylor circular distribution.

2.38 Bayliss distribution, linear. A continuous distribution of a line source that yields a difference pattern with a side-lobe structure similar to that of a sum pattern produced by a Taylor linear distribution.

2.39 beam (of an antenna). The major lobe of the radiation pattern of an antenna.

2.40 beam angle. *See: scan angle.*

2.41 beam axis (of a pencil-beam antenna). The direction, within the major lobe of a pencil-beam antenna, for which the radiation intensity is a maximum.

2.42 beam coverage solid angle (of an antenna over a specified surface). The solid angle, measured in steradians, subtended at the antenna by the footprint of the antenna beam on a specified surface. *See: footprint (of an antenna beam on a specified surface).* *Contrast with: beam solid angle.*

2.43 beam solid angle. The solid angle through which all the radiated power would stream if the power per unit solid angle were constant throughout this solid angle and at the maximum value of the radiation intensity.

2.44 beam steering. Changing the direction of the major lobe of a radiation pattern.

2.45 beamwidth. *See: half-power beamwidth.*

2.46 Beverage antenna. A directional antenna composed of a system of parallel horizontal conductors from one-half to several wavelengths long, terminated to ground at the far end in its characteristic impedance. *Syn: wave antenna.*

2.47 biconical antenna. An antenna consisting of two conical conductors having a common axis and vertex.

2.48 bistatic cross section. The scattering cross section in any specified direction other than back toward the source. *Contrast with: monostatic cross section.*

2.49 blade antenna. A form of monopole antenna that is blade-shaped for strength and low aerodynamic drag.

2.50 boresight. *See: electrical boresight; reference boresight.*

2.51 boresight error. The angular deviation of the electrical boresight of an antenna from its reference boresight.

2.52 broadside array antenna. A linear or planar array antenna whose direction of maximum radiation is perpendicular to the line or plane, respectively, of the array.

2.53 cage antenna. A multi-wire element whose wires are so disposed as to resemble a cylinder, in general of circular cross section; for example, an elongated cage.

2.54 cardinal plane. For an infinite planar array whose elements are arranged in a regular lattice, any plane of symmetry normal to the planar array and parallel to an edge of a lattice cell.

NOTES

1—This term can be applied to a finite array, usually one containing a large number of elements, by the assumption that it is a subset of an infinite array with the same lattice arrangement.

2—This term is used to relate the regular geometrical arrangement of the array elements to the radiation pattern of the antenna.

2.55 Cassegrain reflector antenna. A paraboloidal reflector antenna with a convex subreflector, usually hyperboloidal in shape, located between the vertex and the prime focus of the main reflector.

NOTES

1—To improve the aperture efficiency of the antenna, the shapes of the main reflector and the subreflector are sometimes modified.

2—There are other alternate forms that are referred to as Cassegrainian. Examples include the following: one in which the subreflector is surrounded by a reflecting skirt and one that utilizes a concave hyperboloidal reflector. When referring to these alternate forms the term shall be modified in order to differentiate them from the antenna described in the definition.

2.56 cheese antenna. A reflector antenna having a cylindrical reflector enclosed by two parallel conducting plates perpendicular to the cylinder, spaced more than one wavelength apart. *Contrast with:* **pillbox antenna.**

2.57 circular array. An array of elements whose corresponding points lie on a circle. *Syn:* **ring array.**

NOTE—Practical circular arrays may include arrangements of elements that are congruent under translation or rotation.

2.58 circular Bayliss distribution. *See:* **Bayliss distribution, circular.**

2.59 circular grid array. An array of elements whose corresponding points lie on coplanar concentric circles.

2.60 circularly polarized field vector. At a point in space, a field vector whose extremity describes a circle as a function of time.

NOTE—Circular polarization may be viewed as a special case of elliptical polarization where the axial ratio has become equal to one.

2.61 circularly polarized plane wave. A plane wave whose electric field vector is circularly polarized.

2.62 circular scanning. Scanning where the beam axis of the antenna generates a conical surface.

NOTE—This can include the special case where the cone degenerates to a plane.

2.63 circular Taylor distribution. *See:* **Taylor distribution, circular.**

2.64 coaxial antenna. An antenna comprised of an extension to the inner conductor of a coaxial line and a radiating sleeve that in effect is formed by folding back the outer conductor of the coaxial line. *Contrast with:* **sleeve-dipole antenna.**

2.65 collinear array antenna. A linear array of radiating elements, usually dipoles, with their axes lying in a straight line.

2.66 complex conductivity. For isotropic media, at a particular point, and for a particular frequency, the ratio of the complex amplitude of the total electric current density to the complex amplitude of the electric field strength.

NOTE—The electric field strength and total current density are both expressed as phasors, with the latter composed of the conduction current density plus the displacement current density.

2.67 complex dielectric constant. The complex permittivity of a physical medium in ratio to the permittivity of free space.

2.68 complex permittivity. For isotropic media, the ratio of the complex amplitude of the electric displacement density to the complex amplitude of the electric field strength.

2.69 complex polarization ratio. For a given field vector at a point in space, the ratio of the complex amplitudes of two specified orthogonally polarized field vectors into which the given field vector has been resolved. *See: plane wave, NOTE 2.*

NOTE—For these amplitudes to define definite phase angles, particular unitary vectors (basis vectors) must be chosen for each of the orthogonal polarizations. *See: polarization vector, especially NOTE 1.*

2.70 compound circular horn antenna. A horn antenna of circular cross section with two or more abrupt changes of flare angle or diameter.

2.71 compound horn antenna. *See: compound circular horn antenna; compound rectangular horn antenna.*

2.72 compound interferometer system. An antenna system consisting of two or more interferometer antennas whose outputs are combined using nonlinear circuit elements such that grating lobe effects are reduced.

2.73 compound rectangular horn antenna. A horn antenna of rectangular cross section in which at least one pair of opposing sides has two or more abrupt changes of flare angle or spacing.

2.74 conformal antenna [conformal array]. An antenna [an array] that conforms to a surface whose shape is determined by considerations other than electromagnetic; for example, aerodynamic or hydrodynamic.

2.75 conformal array. *See: conformal antenna.*

2.76 conical array. A two-dimensional array of elements whose corresponding points lie on a conical surface.

2.77 conical scanning. A form of sequential lobing in which the direction of maximum radiation generates a cone whose vertex angle is of the order of the antenna half-power beamwidth.

NOTE—Such scanning may be either rotating or nutating according to whether the direction of polarization rotates or remains unchanged.

2.78 contoured beam antenna. A shaped-beam antenna designed in such a way that when its beam intersects a given surface, the lines of equal power flux density incident upon the surface form specified contours. *See: footprint (of an antenna beam on a specified surface).*

2.79 co-polarization. That polarization that the antenna is intended to radiate [receive]. *See: polarization pattern, NOTES 1 and 2.*

2.80 co-polar (radiation) pattern. A radiation pattern corresponding to the co-polarization. *See: co-polarization.*

2.81 co-polar side lobe level, relative. The maximum relative partial directivity (corresponding to the co-polarization) of a side lobe with respect to the maximum partial directivity (corresponding to the co-polarization) of the antenna.

NOTE—Unless otherwise specified the co-polar side lobe level shall be taken to be that of the highest side lobe of the co-polar radiation pattern.

2.82 corner reflector. A reflecting object consisting of two or three mutually intersecting conducting flat surfaces.

NOTE—Dihedral forms of corner reflectors are frequently used in antennas; trihedral forms with mutually perpendicular surfaces are more often used as radar targets.

2.83 corner reflector antenna. An antenna consisting of a feed and a corner reflector.

2.84 corrugated horn (antenna). A hybrid-mode horn antenna produced by cutting narrow transverse grooves of specified depth in the interior walls of the horn. *See:* **hybrid-mode horn.**

2.85 cosecant-squared beam antenna. A shaped-beam antenna whose pattern in one principal plane consists of a main beam with well-defined side lobes on one side, but with the absence of nulls over an extended angular region adjacent to the peak of the main beam on the other side, with the radiation intensity in this region designed to vary as the cosecant-squared of the angle variable.

NOTE—The most common applications of this antenna are for use in ground-mapping radars and target acquisition radars, since the cosecant-squared coverage provides constant signal return for targets with the same radar cross section at different ranges but a common height.

2.86 counterpoise. A system of conductors, elevated above and insulated from the ground, forming a lower system of conductors of an antenna.

NOTE—The purpose of a counterpoise is to provide a relatively high capacitance and thus a relatively low impedance path to earth. The counterpoise is sometimes used in medium- and low-frequency applications where it would be more difficult to provide an effective ground connection.

2.87 cross polarization. In a specified plane containing the reference polarization ellipse, the polarization orthogonal to a specified reference polarization.

NOTE—The reference polarization is usually the copolarization.

2.88 cross-polar (radiation) pattern. A radiation pattern corresponding to the polarization orthogonal to the co-polarization. *See:* **co-polarization.**

2.89 cross-polar side lobe level, relative. The maximum relative partial directivity (corresponding to the **cross polarization**) of a side lobe with respect to the maximum partial directivity (corresponding to the **co-polarization**) of the antenna.

NOTE—Unless otherwise specified, the cross-polar side lobe level shall be taken to be that of the highest side lobe of the cross-polar radiation pattern.

2.90 cross section. *See:* **bistatic cross section; monostatic cross section; radar cross section; scattering cross section.**

2.91 cylindrical antenna. [Deprecated.] *See:* **cylindrical array; cylindrical dipole.**

2.92 cylindrical array. A two-dimensional array of elements whose corresponding points lie on a cylindrical surface.

2.93 cylindrical dipole (antenna). A dipole, all of whose transverse cross sections are the same, the shape of a cross section of a cylinder being circular.

2.94 cylindrical reflector. A reflector that is a portion of a cylindrical surface.

NOTE—The cylindrical surface is usually parabolic, although other shapes may be employed.

2.95 density-tapered array antenna. *See: space-tapered array antenna.*

2.96 depolarization. The conversion of power from a reference polarization into the cross polarization.

2.97 despun antenna. On a rotating vehicle, an antenna whose beam is scanned such that, with respect to fixed reference axes, the beam is stationary.

2.98 dielectric constant. The real part of the complex dielectric constant.

2.99 dielectric rod antenna. An antenna that employs a shaped dielectric rod as the electrically significant part of a radiating element.

NOTE—The polyrod rod antenna is a notable example of the dielectric rod antenna when constructed of polystyrene.

2.100 difference pattern. A radiation pattern characterized by a pair of main lobes of opposite phase, separated by a single null, plus a family of side lobes, the latter usually desired to be at a low level. *Contrast with: sum pattern.*

NOTE—Antennas used in many radar applications are capable of producing a sum pattern and two orthogonal difference patterns. The difference patterns can be employed to determine the position of a target in a right/left and up/down sense by antenna pattern pointing, which places the target in the null between the twin lobes of each difference pattern.

2.101 dipole. *See: dipole antenna; electrically short dipole; folded dipole (antenna); half-wave dipole; Hertzian electric dipole; Hertzian magnetic dipole; microstrip dipole; sleeve dipole antenna.*

2.102 dipole antenna. Any one of a class of antennas producing a radiation pattern approximating that of an elementary electric dipole. *Syn: doublet antenna.*

NOTE—Common usage considers the dipole antenna to be a metal radiating structure that supports a line current distribution similar to that of a thin straight wire so energized that the current has a node only at each end.

2.103 directional antenna. An antenna having the property of radiating or receiving electromagnetic waves more effectively in some directions than others.

NOTE—This term is usually applied to an antenna whose maximum directivity is significantly greater than that of a half-wave dipole.

2.104 directional-null. A sharp minimum in a radiation pattern that has been produced for the purpose of direction-finding or the suppression of unwanted radiation in a specified direction.

2.105 directional-null antenna. An antenna whose radiation pattern contains one or more directional nulls. *See: null-steering antenna system.*

2.106 directive gain. [Deprecated.] *See: directivity.*

2.107 directivity (of an antenna) (in a given direction). The ratio of the radiation intensity in a given direction from the antenna to the radiation intensity averaged over all directions.

NOTES

1—The average radiation intensity is equal to the total power radiated by the antenna divided by 4π .

2—If the direction is not specified, the direction of maximum radiation intensity is implied.

2.108 directivity, partial (of an antenna for a given polarization). In a given direction, that part of the radiation intensity corresponding to a given polarization divided by the total radiation intensity averaged over all directions.

NOTE—The (total) directivity of an antenna, in a specified direction, is the sum of the partial directivities for any two orthogonal polarizations.

2.109 director element. A parasitic element located forward of the driven element of an antenna, intended to increase the directivity of the antenna in the forward direction.

2.110 discone antenna. A biconical antenna with one cone having a vertex angle of 180° . *See: biconical antenna.*

2.111 Dolph-Chebyshev array antenna. [Deprecated.] *See: Dolph-Chebyshev distribution.*

2.112 Dolph-Chebyshev distribution. A set of excitation coefficients for an equispaced linear array antenna such that the array factor can be expressed as a Chebyshev polynomial.

2.113 doublet antenna. *See: dipole antenna.*

2.114 driven element. A radiating element coupled directly to the feed line of an antenna.

2.115 effective area (of an antenna) (in a given direction). In a given direction, the ratio of the available power at the terminals of a receiving antenna to the power flux density of a plane wave incident on the antenna from that direction, the wave being polarization matched to the antenna. *See: polarization match.*

NOTES

1—If the direction is not specified, the direction of maximum radiation intensity is implied.

2—The effective area of an antenna in a given direction is equal to the square of the operating wavelength times its gain in that direction divided by 4π .

2.116 effective area, partial (of an antenna for a given polarization and direction). In a given direction, the ratio of the available power at the terminals of a receiving antenna to the power flux density of a plane wave incident on the antenna from that direction and with a specified polarization differing from the receiving polarization of the antenna.

2.117 effective height of an antenna (high-frequency usage). The height of the antenna center of radiation above the ground level.

NOTE—For an antenna with a symmetrical current distribution, the center of radiation is the center of distribution. For an antenna with asymmetrical current distribution, the center of radiation is the center of current moments when viewed from directions near the direction of maximum radiation.

2.118 effective isotropically radiated power. *See: equivalent isotropically radiated power.*

2.119 effective length of a linearly polarized antenna. For a linearly polarized antenna receiving a plane wave from a given direction, the ratio of the magnitude of the open circuit voltage developed at the terminals of the antenna to the magnitude of the electric field strength in the direction of the antenna polarization.

NOTES

1—Alternatively, the effective length is the length of a thin straight conductor oriented perpendicularly to the given direction and parallel to the antenna polarization, having a uniform current equal to that at the antenna terminals and producing the same far-field strength as the antenna in that direction.

2—In low-frequency usage, the effective length of a vertically polarized ground-based antenna is frequently referred to as effective height. Such usage should not be confused with **effective height of an antenna (high-frequency usage)**.

2.120 effective radiated power (ERP). In a given direction, the relative gain of a transmitting antenna with respect to the maximum directivity of a half-wave dipole multiplied by the net power accepted by the antenna from the connected transmitter. *Contrast with: equivalent isotropically radiated power. Syn: equivalent radiated power.*

2.121 electrical boresight. The tracking axis as determined by an electrical indication, such as the null direction of a conical-scanning or monopulse antenna system, or the beam-maximum direction of a highly directive antenna.

2.122 electrically short dipole. A dipole whose total length is small compared to the wavelength.

NOTE—For the common case that the two arms are collinear, the radiation pattern approximates that of a Hertzian dipole.

2.123 electrically small antenna. An antenna whose dimensions are such that it can be contained within a sphere whose diameter is small compared to a wavelength at the frequency of operation.

2.124 electric dipole. *See: Hertzian electric dipole.*

2.125 electromagnetic lens. *See: lens, electromagnetic.*

2.126 electromagnetic radiation. *See: radiation, electromagnetic.*

2.127 electronic scanning. Scanning an antenna beam by electronic or electric means without moving parts. *Syn: inertialess scanning.*

2.128 element. *See: array element; director element; driven element; linear electric current element; linear magnetic current element; multi-wire element; parasitic element; radiating element; reflector element.*

2.129 element cell (of an array antenna). In an array having a regular arrangement of elements that can be made congruent by translation, an element and a region surrounding it that, when repeated by translation, covers the entire array without gaps or overlap between cells.

NOTE—There are many possible choices for such a cell. Some may be more convenient than others for analytic purposes.

2.130 elliptically polarized field vector. At a point in space, a field vector whose extremity describes an ellipse as a function of time.

NOTE—Any single-frequency field vector is elliptically polarized if “elliptical” is understood in the wide sense as including circular and linear. Often, however, the expression is used in the strict sense meaning noncircular and nonlinear.

2.131 elliptically polarized plane wave. A plane wave whose electric field vector is elliptically polarized.

2.132 end capacitor. A conducting element or group of conducting elements, connected at the end of a radiating element of an antenna, to modify the current distribution on the antenna, thus changing its input impedance.

2.133 end-fire array antenna. A linear array antenna whose direction of maximum radiation lies along the line of the array.

2.134 E-plane, principal. For a linearly polarized antenna, the plane containing the electric field vector and the direction of maximum radiation.

2.135 equivalent flat plate area of a scattering object. For a given scattering object, an area equal to the wavelength times the square root of the ratio of the monostatic cross section to 4π .

NOTE—A perfectly reflecting plate parallel to the incident wavefront and having this area, if it is large compared to the wavelength, will have approximately the same monostatic cross section as the object.

2.136 equivalent isotropically radiated power (EIRP). In a given direction, the gain of a transmitting antenna multiplied by the net power accepted by the antenna from the connected transmitter. *Syn:* **effective isotropically radiated power.**

2.137 equivalent radiated power. *See:* **effective radiated power.**

2.138 equivalent sources. *See:* **Huygens' sources.**

2.139 excitation (of an array antenna). For an array of radiating elements, the specification, in amplitude and phase, of either the voltage applied to each element or the input current to each element.

2.140 excitation coefficients. The relative values, in amplitude and phase, of the excitation currents or voltages of the radiating elements of an array antenna. *Syn:* **feeding coefficients.**

2.141 fan-beam antenna. An antenna producing a major lobe whose transverse cross section has a large ratio of major to minor dimensions.

2.142 far-field (radiation) pattern. Any radiation pattern obtained in the far-field of an antenna.

NOTE—Far-field patterns are usually taken over paths on a spherical surface. *See:* **radiation pattern cut; radiation sphere.**

2.143 far-field region. That region of the field of an antenna where the angular field distribution is essentially independent of the distance from a specified point in the antenna region.

NOTES

1—In free space, if the antenna has a maximum overall dimension, D , that is large compared to the wavelength, the far-field region is commonly taken to exist at distances greater than $2D^2/\lambda$ from the antenna, λ being the wavelength. The far-field patterns of certain antennas, such as multi-beam reflector antennas, are sensitive to variations in phase over their apertures. For these antennas, $2D^2/\lambda$ may be inadequate.

2—In physical media, if the antenna has a maximum overall dimension, D , that is large compared to $\pi/|\gamma|$, the far-field region can be taken to begin approximately at a distance equal to $|\gamma|D^2/\pi$ from the antenna, γ being the propagation constant in the medium.

2.144 far-field region in physical media. *See:* **far-field region, NOTE 2.**

2.145 feed of an antenna. (A) For continuous aperture antennas, the feed is the primary radiator; for example, a horn feeding a reflector. (B) For array antennas, that portion of the antenna system which functions to produce the excitation coefficients.

2.146 feeding coefficients. *See:* **excitation coefficients.**

2.147 feed line. A transmission line interconnecting an antenna and a transmitter or receiver or both.

2.148 field pattern. *See:* **radiation pattern.**

2.149 figure of merit (of an antenna) (G/T). The ratio of the gain to the noise temperature of an antenna.

NOTES

1—Usually the antenna-receiver system figure of merit is specified. For this case, the figure of merit is the gain of the antenna divided by the system noise temperature referred to the antenna terminals.

2—The system figure of merit at any reference plane in the RF system is the same as that taken at the antenna terminals since both the gain and system noise temperature are referred to the same reference plane.

2.150 fishbone antenna. An end-fire, traveling wave antenna consisting of a balanced transmission line to which is coupled, usually through lumped circuit elements, an array of closely spaced, coplanar dipoles.

2.151 flat-top antenna. A short vertical monopole antenna with an end capacitor whose elements are all in the same horizontal plane. *See:* **end capacitor; top-loaded vertical antenna.**

2.152 flush-mounted antenna. An antenna constructed into the surface of a mechanism, or of a vehicle, without affecting the shape of that surface. *Contrast with:* **conformal antenna.**

2.153 folded dipole (antenna). An antenna composed of two or more parallel, closely-spaced dipole antennas connected together at their ends with one of the dipole antennas fed at its center and the others short-circuited at their centers.

2.154 folded monopole (antenna). A monopole antenna formed from half of a folded dipole with the unfed element(s) directly connected to the imaging plane.

2.155 footprint (of an antenna beam on a specified surface). An area bounded by a contour on a specified surface formed by the intersection of the surface and that portion of the beam of an antenna above a specified minimum gain level, the orientation of the beam with respect to the surface being specified.

2.156 Fraunhofer pattern. A radiation pattern obtained in the Fraunhofer region of an antenna.

NOTE—For an antenna focused at infinity, a Fraunhofer pattern is a far-field pattern.

Fraunhofer region. The region in which the field of an antenna is focused.

NOTES

1—In the Fraunhofer region of an antenna focused at infinity, the values of the fields, when calculated from knowledge of the source distribution of an antenna, are sufficiently accurate when the quadratic phase terms (and higher order terms) are neglected.

2—*See:* NOTE 2 of **far-field region** for a more restricted usage.

2.157 free-space loss. The loss between two isotropic radiators in free space, expressed as a power ratio.

NOTE—The free-space loss is not due to dissipation, but rather due to the fact that the power flux density decreases with the square of the separation distance. It is usually expressed in decibels and is given by the formula $20\log(4\pi R/\lambda)$, where R is the separation of the two antennas and λ is the wavelength.

2.158 Fresnel contour. The locus of points on a surface for which the sum of the distances to a source point and an observation point is a constant, differing by a multiple of a half-wavelength from the minimum value of the sum of the distances.

NOTE—This definition applies to media which are isotropic and homogeneous. For the general case, the distances along optical paths must be employed.

2.159 Fresnel lens antenna. An antenna consisting of a feed and a lens, usually planar, that transmits the radiated power from the feed through the central zone and alternate Fresnel zones of the illuminating field on the lens. *Syn:* **zone-plate lens antenna.**

2.160 Fresnel pattern. A radiation pattern obtained in the Fresnel region.

2.161 Fresnel region. The region (or regions) adjacent to the region in which the field of an antenna is focused (that is, just outside the Fraunhofer region).

NOTES

1—In the Fresnel region in space, the values of the fields, when calculated from knowledge of the source distribution of an antenna, are insufficiently accurate unless the quadratic phase terms are taken into account, but are sufficiently accurate if the quadratic phase terms are included.

2—*See:* NOTE 2 of **near-field region, radiating** for a more restricted usage.

2.162 Fresnel zone. The region on a surface between successive Fresnel contours.

NOTE—Fresnel zones are usually numbered consecutively, with the first zone containing the minimum path length.

2.163 front-to-back ratio. The ratio of the maximum directivity of an antenna to its directivity in a specified rearward direction.

NOTES

1—This definition is usually applied to beamtype patterns.

2—If the rearward direction is not specified, it shall be taken to be that of the maximum directivity in the rearward hemisphere relative to the antenna's orientation.

2.164 gain. *See:* **gain, partial (of an antenna for a given polarization); realized gain; realized gain, partial (of an antenna for a given polarization).**

2.165 gain (in a given direction). The ratio of the radiation intensity, in a given direction, to the radiation intensity that would be obtained if the power accepted by the antenna were radiated isotropically. *Syn:* **absolute gain (of an antenna).**

NOTES

1—Gain does not include losses arising from impedance and polarization mismatches.

2—The radiation intensity corresponding to the isotropically radiated power is equal to the power accepted by the antenna divided by 4π .

3—If an antenna is without dissipative loss, then in any given direction, its gain is equal to its directivity.

4—If the direction is not specified, the direction of maximum radiation intensity is implied.

5—The term **absolute gain** is used in those instances where added emphasis is required to distinguish gain from relative gain; for example, absolute gain measurements.

2.166 gain, partial (of an antenna for a given polarization). In a given direction, that part of the radiation intensity corresponding to a given polarization divided by the radiation intensity that would be obtained if the power accepted by the antenna were radiated isotropically.

NOTE—The (total) gain of an antenna, in a specified direction, is the sum of the partial gains for any two orthogonal polarizations.

2.167 geodesic lens antenna. A lens antenna having a two-dimensional lens, with uniform index of refraction, disposed on a surface such that the rays in the lens follow geodesic (minimal) paths of the surface.

2.168 grating lobe. A lobe, other than the main lobe, produced by an array antenna when the interelement spacing is sufficiently large to permit the in-phase addition of radiated fields in more than one direction.

2.169 Gregorian reflector antenna. A paraboloidal reflector antenna with a concave subreflector, usually ellipsoidal in shape, located at a distance from the vertex of the main reflector that is greater than the prime focal length of the main reflector.

NOTE—To improve the aperture efficiency of the antenna, the shapes of the main reflector and subreflector are sometimes modified.

2.170 ground plane. A conducting or reflecting plane functioning to image a radiating structure. *Syn:* **imaging plane.**

2.171 ground rod. A conducting rod serving as an electrical connection with the ground.

2.172 ground system. That portion of an antenna consisting of a system of conductors or a conducting surface in or on the ground.

2.173 half-power beamwidth. In a radiation pattern cut containing the direction of the maximum of a lobe, the angle between the two directions in which the radiation intensity is one-half the maximum value. *See:* **principal half-power beamwidths.**

2.174 half-wave dipole. A wire antenna consisting of two straight collinear conductors of equal length, separated by a small feeding gap, with each conductor approximately a quarter-wavelength long.

NOTE—This antenna gets its name from the fact that its overall length is approximately a half-wavelength. In practice, the length is usually slightly smaller than a half-wavelength—enough to cause the input impedance to be pure real ($jX = 0$).

2.175 helical antenna. An antenna whose configuration is that of a helix.

NOTE—The diameter, pitch, and number of turns in relation to the wavelength provide control of the polarization state and directivity of helical antennas.

2.176 Hertzian electric dipole. An elementary source consisting of a time-harmonic electric current element of specified direction and infinitesimal length. *Syn:* **linear [lineal] electric current element.**

NOTES

1—The continuity equation relating current to charge requires that opposite ends of the current element be terminated by equal and opposite amounts of electric charge, these amounts also varying harmonically with time.

2—As its length approaches zero, the current must approach infinity in such a manner that the product of current and length remains finite.

2.177 Hertzian magnetic dipole. A fictitious elementary source consisting of a time-harmonic magnetic current element of specified direction and infinitesimal length. *Syn:* **linear [lineal] magnetic current element.**

NOTES

1—The continuity equation relating current to charge requires that opposite ends of the current element be terminated by equal and opposite amounts of magnetic charge, these amounts also varying harmonically with time.

2—As its length approaches zero, the current must approach infinity in such a manner that the product of current and length remains finite.

3—A magnetic dipole has the same radiation pattern as an infinitesimally small electric current loop.

2.178 hoghorn antenna. A reflector antenna consisting of a sectoral horn that physically intersects a reflector in the form of a parabolic cylinder, a part of one of the nonparallel sides of the horn being removed to form the antenna aperture.

2.179 horizontally polarized field vector. A linearly polarized field vector whose direction is horizontal.

2.180 horizontally polarized plane wave. A plane wave whose electric field vector is horizontally polarized.

2.181 horn (antenna). An antenna consisting of a waveguide section in which the cross sectional area increases towards an open end that is the aperture.

2.182 horn reflector antenna. An antenna consisting of a portion of a paraboloidal reflector fed with an offset horn that physically intersects the reflector, part of the wall of the horn being removed to form the antenna aperture.

NOTE—The horn is usually either pyramidal or conical, with an axis perpendicular to that of the paraboloid.

2.183 H-plane, principal. For a linearly polarized antenna, the plane containing the magnetic field vector and the direction of maximum radiation.

2.184 Huygens' source radiator. An elementary radiator having the radiation properties of an infinitesimal area of a propagating electromagnetic wavefront.

2.185 Huygens' sources. Electric and magnetic sources that, if properly distributed on a closed surface S in substitution for the actual sources inside S , will ensure the result that the electromagnetic field at all points outside S is unchanged. *Syn:* **equivalent sources.**

2.186 hybrid-mode horn (antenna). A horn antenna excited by one or more hybrid waveguide modes in order to produce a specified aperture illumination.

2.187 imaging plane. *See:* **ground plane.**

2.188 impedance. *See:* **active impedance (of an array element); impedance mismatch factor; input impedance (of an antenna); intrinsic impedance; isolated impedance (of an array element); mutual coupling effect (on input impedance of an array element); mutual impedance; self-impedance of an array element.**

2.189 impedance mismatch factor. The ratio of the power accepted by an antenna to the power incident at the antenna terminals from the transmitter.

NOTE—The impedance mismatch factor is equal to one minus the magnitude squared of the input reflection coefficient of the antenna.

2.190 inertialess scanning. *See: electronic scanning.*

2.191 input impedance (of an antenna). The impedance presented by an antenna at its terminals.

2.192 integrated antenna system. A radiator with an active or nonlinear circuit element or network incorporated physically within the structure of the radiator.

2.193 intercardinal plane. Any plane that contains the intersection of two successive cardinal planes and is at an intermediate angular position.

NOTE—In practice, the intercardinal planes are located by dividing the angle between successive cardinal planes into equal parts. Often, it is sufficient to bisect the angle so that there is only one intercardinal plane between successive cardinal planes.

2.194 interferometer antenna. An array antenna in which the interelement spacings are large compared to wavelength and element size so as to produce grating lobes.

2.195 intrinsic impedance. [Deprecated in the sense of input impedance of an antenna.]

2.196 invisible range. *See: visible range.*

2.197 isolated impedance (of an array element). The input impedance of a radiating element of an array antenna with all other elements of the array absent.

2.198 isolation between antennas. A measure of power transfer from one antenna to another.

NOTE—The isolation between antennas is the ratio of power input to one antenna to the power received by the other, usually expressed in decibels.

2.199 isotropic radiator. A hypothetical, lossless antenna having equal radiation intensity in all directions.

NOTE—An isotropic radiator represents a convenient reference for expressing the directive properties of actual antennas.

2.200 leaky-wave antenna. An antenna that couples power in small increments per unit length, either continuously or discretely, from a traveling wave structure to free space.

2.201 left-hand polarization of a field vector. *See: sense of polarization.*

2.202 left-hand polarization of a plane wave. *See: sense of polarization.*

2.203 lens antenna. An antenna consisting of an electromagnetic lens and a feed that illuminates it.

2.204 lens, electromagnetic. A three-dimensional structure, through which electromagnetic waves can pass, possessing an index of refraction that may be a function of position and a shape that is chosen so as to control the exiting aperture illumination.

2.205 lineal electric current element. *See: Hertzian electric dipole.*

2.206 lineal magnetic current element. *See:* **Hertzian magnetic dipole.**

2.207 linear antenna. An antenna consisting of one or more segments of straight conducting cylinders.

NOTES

1—This term has restricted usage, and applies to straight cylindrical wire antennas. This term should not be confused with the conventional usage of “linear” in circuit theory.

2—*Contrast with:* **linear array antenna.**

2.208 linear array antenna. A one-dimensional array of elements whose corresponding points lie along a straight line.

2.209 linear Bayliss distribution. *See:* **Bayliss distribution, linear.**

2.210 linear electric current element. *See:* **Hertzian electric dipole.**

2.211 linear magnetic current element. *See:* **Hertzian magnetic dipole.**

2.212 linear Taylor distribution. *See:* **Taylor distribution, linear.**

2.213 linearly polarized field vector. At a point in space, a field vector whose extremity describes a straight line segment as a function of time.

NOTE—Linear polarization may be viewed as a special case of elliptical polarization where the axial ratio has become infinite.

2.214 linearly polarized plane wave. A plane wave whose electric field vector is linearly polarized.

2.215 line source. A continuous distribution of sources of electromagnetic radiation, lying along a line segment.

NOTE—Most often in practice the line segment is straight.

2.216 line source corrector. A linear array antenna feed with radiating element locations and excitations chosen to correct for aberrations present in the focal region fields of a reflector.

2.217 loaded linear antenna. *See:* **sectionalized linear antenna.**

2.218 loading. The modification of a basic antenna such as a dipole or monopole caused by the addition of conductors or circuit elements that change the input impedance or current distribution or both.

2.219 lobe. *See:* **back lobe; beam of an antenna; major lobe; minor lobe; side lobe; shoulder lobe; vestigial lobe.**

2.220 lobe switching. A form of scanning in which the direction of maximum radiation is discretely changed by switching. *See:* **sequential lobing.**

2.221 log periodic antenna. Any one of a class of antennas having a structural geometry such that its impedance and radiation characteristics repeat periodically as the logarithm of frequency.

2.222 long-wire antenna. A wire antenna that, by virtue of its considerable length in comparison with the operating wavelength, provides a directional radiation pattern.

2.223 loop antenna. An antenna whose configuration is that of a loop.

NOTE—If the electric current in the loop, or in multiple parallel turns of the loop, is essentially uniform and the loop circumference is small compared with the wavelength, the radiated pattern approximates that of a Hertzian magnetic dipole.

2.224 loop stick antenna. A loop receiving antenna with a ferrite rod core used for increasing its radiation efficiency.

2.225 Luneburg lens antenna. A lens antenna with a circular cross section having an index of refraction varying only in the radial direction such that a feed located on or near a surface or edge of the lens produces a major lobe diametrically opposite the feed.

2.226 magnetic dipole. *See:* **Hertzian magnetic dipole.**

2.227 main lobe. *See:* **major lobe.**

2.228 main reflector. The largest reflector of a multiple reflector antenna.

2.229 major lobe. The radiation lobe containing the direction of maximum radiation. *Syn:* **main lobe.**

NOTE—In certain antennas, such as multilobed or splitbeam antennas, there may exist more than one major lobe.

2.230 maximum relative side lobe level. *See:* **side lobe level, maximum relative.**

2.231 mean side lobe level. The average value of the relative power pattern of an antenna taken over a specified angular region, which excludes the main beam, the power pattern being relative to the peak of the main beam.

2.232 microstrip antenna. An antenna that consists of a thin metallic conductor bonded to a thin grounded dielectric substrate.

NOTE—The metallic conductor typically has some regular shape; for example, rectangular, circular, or elliptical. Feeding is often by means of a coaxial probe or a microstrip transmission line.

2.233 microstrip array. An array of microstrip antennas.

2.234 microstrip dipole. A microstrip antenna of rectangular shape with its width much smaller than its length.

2.235 Mills cross antenna system. A multiplicative array antenna system consisting of two linear receiving arrays positioned at right angles to one another and connected together by a phase modulator or switch such that the effective angular response of the output is related to the product of the radiation patterns of the two arrays.

2.236 minor lobe. Any radiation lobe except a major lobe. *See:* **back lobe; side lobe.**

2.237 monopole. An antenna, constructed above an imaging plane, that produces a radiation pattern approximating that of an electric dipole in the half-space above the imaging plane.

2.238 monopulse. Simultaneous lobing whereby direction-finding information is obtainable from a single pulse.

2.239 monostatic cross section. The scattering cross section in the direction toward the source. *Contrast with:* **bistatic cross section.** *Syn:* **back-scattering cross section.**

2.240 multi-beam antenna. An antenna capable of creating a family of major lobes from a single non-moving aperture, through use of a multipoint feed, with one-to-one correspondence between input ports and member lobes, the latter characterized by having unique main beam pointing directions.

NOTE—Often, the multiple main beam angular positions are arranged to provide complete coverage of a solid angle region of space.

2.241 multiple-tuned antenna. An antenna designed to operate, without modification, in any of a number of pre-set frequency bands.

2.242 multiplicative array antenna system. A signal-processing antenna system consisting of two or more receiving antennas and circuitry in which the effective angular response of the output of the system is related to the product of the radiation patterns of the separate antennas.

2.243 multi-wire element. A radiating element composed of several wires connected in parallel, the assemblage being the electrical equivalent of a single conductor larger than any one of the individual wires.

2.244 mutual coupling effect (A) (on the radiation pattern of an array antenna). For array antennas, the change in antenna pattern from the case when a particular feeding structure is attached to the array and mutual impedances among elements are ignored in deducing the excitation to the case when the same feeding structure is attached to the array and mutual impedances among elements are included in deducing the excitation.

(B) (on input impedance of an array element). For array antennas, the change in input impedance of an array element from the case when all other elements are present but open-circuited to the case when all other elements are present and excited.

2.245 mutual impedance. The mutual impedance between any two terminal pairs in a multielement array antenna is equal to the open-circuit voltage produced at the first terminal pair divided by the current supplied to the second when all other terminal pairs are open-circuited.

2.246 near-field (radiation) pattern. Any radiation pattern obtained in the near-field of an antenna. *See: Fresnel pattern.*

NOTE—Near-field patterns are usually taken over paths on planar, cylindrical, or spherical surfaces. *See: radiation pattern cut.*

2.247 near-field region. That part of space between the antenna and far-field region.

NOTE—In lossless media, the near-field may be further subdivided into reactive and radiating near-field regions.

2.248 near-field region in physical media. [Deprecated.]

2.249 near-field region, radiating. That portion of the near-field region of an antenna between the farfield and the reactive portion of the near-field region, wherein the angular field distribution is dependent upon distance from the antenna.

NOTES

1—If the antenna has a maximum overall dimension that is not large compared to the wavelength, this field region may not exist.

2—For an antenna focused at infinity, the radiating near-field region is sometimes referred to as the Fresnel region on the basis of analogy to optical terminology.

2.250 near-field region, reactive. That portion of the near-field region immediately surrounding the antenna, wherein the reactive field predominates.

NOTE—For a very short dipole, or equivalent radiator, the outer boundary is commonly taken to exist at a distance $\lambda/2\pi$ from the antenna surface, where λ is the wavelength.

2.251 noise temperature of an antenna. The temperature of a resistor having an available thermal noise power per unit bandwidth equal to that at the antenna output at a specified frequency.

NOTE—Noise temperature of an antenna depends on its coupling to all noise sources in its environment, as well as noise generated within the antenna.

2.252 normalized directivity. *See: antenna [aperture] illumination efficiency.*

2.253 null steering. To control, usually electronically, the direction at which a directional null appears in the radiation pattern of an operational antenna.

2.254 null-steering antenna system. An antenna having in its radiation pattern one or more directional nulls that can be steered, usually electronically.

2.255 offset paraboloidal reflector. *See: paraboloidal reflector.*

2.256 offset paraboloidal reflector antenna. A reflector antenna whose main reflector is a portion of a paraboloid that is not symmetrical with respect to its focal axis, and does not include the vertex so that aperture blockage by the feed is reduced or eliminated.

2.257 omnidirectional antenna. An antenna having an essentially non-directional pattern in a given plane of the antenna and a directional pattern in any orthogonal plane. *Contrast with: isotropic antenna.*

NOTE—For ground-based antennas, the omnidirectional plane is usually horizontal.

2.258 orthogonal polarization (with respect to a specified polarization). In a common plane of polarization, the polarization for which the inner product of the corresponding polarization vector and that of the specified polarization is equal to zero. *See: polarization vector, NOTE 2* for a definition of the inner product.

NOTES

1—The two orthogonal polarizations can be represented as two diametrical points on the Poincaré sphere.

2—Two elliptically polarized fields having the same plane of polarization have orthogonal polarizations if their polarization ellipses have the same axial ratio, major axes at right angles, and opposite senses of polarization.

2.259 parabolic torus reflector. A toroidal reflector formed by rotating a segment of a parabola about a non-intersecting co-planar line.

2.260 paraboloidal reflector. An axially symmetric reflector that is a portion of a paraboloid.

NOTE—This term may be applied to any reflector that is a portion of a paraboloid, provided the term is appropriately qualified. For example, if the reflector is a portion of a paraboloid but does not include its vertex, then it may be called an **off-set paraboloidal reflector**.

2.261 parallel [perpendicular] polarization. A linear polarization for which the field vector is parallel [perpendicular] to some reference plane.

NOTE—These terms are applied mainly to uniform plane waves incident upon a plane of discontinuity (surface of the earth, surface of a dielectric or a conductor). Then, the convention is to take as reference the plane of incidence; that is, the plane containing the direction of propagation and the normal to the surface of discontinuity. If these two directions coincide, the reference plane must be specified by some other convention.

2.262 parasitic element. A radiating element that is not connected to the feed lines of an antenna and that materially affects the radiation pattern or impedance of an antenna, or both. *Contrast with:* **driven element.**

2.263 partial directivity (of an antenna, for a given polarization). *See:* **directivity, partial (of an antenna, for a given polarization).**

2.264 partial effective area (of an antenna, for a given polarization and direction). *See:* **effective area, partial (of an antenna for a given polarization and direction).**

2.265 partial gain (of an antenna for a given polarization). *See:* **gain, partial (of an antenna for a given polarization).**

2.266 partial realized gain (of an antenna for a given polarization. *See:* **realized gain, partial (of an antenna for a given polarization).**

2.267 pencil-beam antenna. An antenna whose radiation pattern consists of a single main lobe with narrow principal half-power beamwidths and side lobes having relatively low levels.

NOTE—The main lobe usually has approximately elliptical contours of equal radiation intensity in the angular region around the peak of the main lobe. This type of pattern is diffraction-limited in practice. It is often called a sum pattern in radar applications.

2.268 periscope antenna. An antenna consisting of a very directive feed located close to ground level and oriented so that its beam illuminates an elevated reflector that is oriented so as to produce a horizontal beam.

2.269 perpendicular polarization. *See:* **parallel polarization.**

2.270 phase center. The location of a point associated with an antenna such that, if it is taken as the center of a sphere whose radius extends into the far-field, the phase of a given field component over the surface of the radiation sphere is essentially constant, at least over that portion of the surface where the radiation is significant.

NOTE—Some antennas do not have a unique phase center.

2.271 phase of a circularly polarized field vector. In the plane of polarization, the angle that the field vector makes, at a time taken as the origin, with a reference direction and with the angle counted as positive if it is in the same direction as the sense of polarization and negative if it is in the opposite direction to the sense of polarization.

2.272 phase pattern (of an antenna). The spatial distribution of the relative phase of a field vector excited by an antenna.

NOTES

1—The phase may be referred to any arbitrary reference.

2—The distribution of phase over any path, surface, or radiation pattern cut is also called a phase pattern.

2.273 phase, relative, of an elliptically polarized field vector. The phase angle of the unitary factor by which the polarization-phase vector for the given field vector differs from that of a reference field vector with the same polarization.

NOTES

1—The relative phase of an elliptically polarized field \vec{E}_1 can be defined with respect to that of another field \vec{E}_0 having the same polarization. In that case, the polarization vectors \hat{e}_1 and \hat{e}_0 have the same direction and, being of unit magnitudes, they differ only by a unitary factor: $\hat{e}_1 = e^{j\alpha}\hat{e}_0$. The angle α is the phase difference between \vec{E}_1 and \vec{E}_0 .

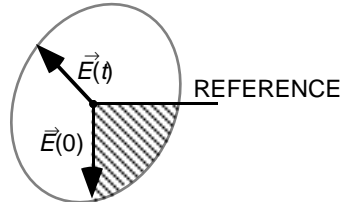

2—The field vectors $\vec{E}_1(t) = \text{Re}\vec{E}_1 e^{j\omega t}$ and $\vec{E}_0(t) = \text{Re}\vec{E}_0 e^{j\omega t}$ describe similar ellipses as t varies. The angle α is 2π times the area of the sector shown on the figure divided by the area of the ellipse described by the extremity of $\vec{E}_0(t)$. For circular polarization, α is the angle between \vec{E}_0 and \vec{E}_1 at any instant of time.

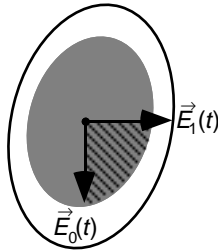

3—The phase of an elliptically polarized field vector can be expressed relative to a spatial direction in its plane of polarization. For example, the phase angle is given by 2π times the area of the sector shown on the figure, which is bounded by $\vec{E}(0)$ and the reference, divided by the area of the ellipse described by $\vec{E}(t)$. The angle is positive if it is in the same direction as the sense of polarization and negative if it is in the direction opposite to the sense of polarization.

2.274 pillbox antenna. A reflector antenna having a cylindrical reflector enclosed by two parallel conducting plates perpendicular to the cylinder, spaced less than one wavelength apart. *Contrast with:* **cheese antenna.**

2.275 planar array. A two-dimensional array of elements whose corresponding points lie in a plane.

2.276 plane of polarization. A plane containing the polarization ellipse.

NOTES

1—When the ellipse degenerates into a line segment, the plane of polarization is not uniquely defined. In general, any plane containing the segment is acceptable; however, for a plane wave in an isotropic medium, the plane of polarization is taken to be normal to the direction of propagation.

2—In optics, the expression *plane of polarization* is associated with a linearly polarized plane wave (sometimes called a *plane polarized wave*) and is defined as a plane containing the field vector of interest and the direction of propagation. This usage would contradict the above one and is deprecated.

2.277 plane polarized wave. *See:* **plane of polarization.**

2.278 plane wave. A wave in which the only spatial dependence of the field vectors is through a common exponential factor whose exponent is a linear function of position.

NOTES

1—In a linear, homogeneous, and isotropic space the electric field vector, magnetic field vector and the propagation vector are mutually perpendicular. The ratio of the magnitude of the electric field vector to the magnitude of the magnetic field vector is equal to the intrinsic impedance of the medium; for free space the intrinsic impedance is equal to 376.730Ω or approximately $120\pi \Omega$.

2—A plane wave can be resolved into two component waves corresponding to two orthogonal polarizations. The total power flux density of the plane wave at a given point in space is equal to the sum of the power flux densities in the orthogonal component waves.

2.279 Poincaré sphere. A sphere whose points are associated in a one-to-one fashion with all possible polarization states of a plane wave [field vector] according to the following rules: The longitude equals twice the tilt angle and the latitude is twice the angle whose cotangent is the negative of the axial ratio of the polarization ellipse.

NOTES

1—For this definition, the axial ratio carries a sign. *See:* **axial ratio (of a polarization ellipse)**, **NOTE**.

2—The points of the northern hemisphere of the Poincaré sphere represent polarizations with a left-hand sense and those of the southern hemisphere represent polarization with a right-hand sense. The north pole represents left-hand circular polarization and the south pole right-hand circular polarization. The points of the equator represent all possible linear polarizations.

2.280 polarization (of an antenna). In a given direction from the antenna, the polarization of the wave transmitted by the antenna. *See:* **polarization of a wave radiated by an antenna**.

NOTE—When the direction is not stated, the polarization is taken to be the polarization in the direction of maximum gain.

2.281 polarization [of a wave (radiated by an antenna in a specified direction)]. In a specified direction from an antenna and at a point in its far field, the polarization of the (locally) plane wave that is used to represent the radiated wave at that point.

NOTE—At any point in the far field of an antenna, the radiated wave can be represented by a plane wave whose electric field strength is the same as that of the wave and whose direction of propagation is in the radial direction from the antenna. As the radial distance approaches infinity, the radius of curvature of the radiated wave's phase front also approaches infinity, and thus, in any specified direction, the wave appears locally as a plane wave.

2.282 polarization efficiency. The ratio of the power received by an antenna from a given plane wave of arbitrary polarization to the power that would be received by the same antenna from a plane wave of the same power flux density and direction of propagation, whose state of polarization has been adjusted for a maximum received power. *Syn:* **polarization mismatch factor**.

NOTES

1—The polarization efficiency is equal to the square of the magnitude of the inner product of the polarization vector describing the receiving polarization of the antenna and the polarization vector of the plane wave incident at the antenna. *See:* **polarization vector**, **NOTE 2** for definition of the inner product.

2—If the receiving polarization of an antenna and the polarization of an incident plane wave are properly located as points on the Poincaré sphere, then the polarization efficiency is given by the square of the cosine of one-half the angular separation of the two points.

2.283 polarization match. The condition that exists when a plane wave, incident upon an antenna from a given direction, has a polarization that is the same as the receiving polarization of the antenna in that direction. *See:* **receiving polarization (of an antenna)**.

2.284 polarization mismatch factor. *See: polarization efficiency.*

2.285 polarization mismatch loss. The magnitude, expressed in decibels, of the polarization efficiency.

2.286 polarization pattern (of an antenna). (A) The spatial distribution of the polarizations of a field vector excited by an antenna taken over its radiation sphere. (B) The response of a given antenna to a linearly polarized plane wave incident from a given direction and whose direction of polarization is rotating about an axis parallel to its propagation vector; the response being plotted as a function of the angle that the direction of polarization makes with a given reference direction.

NOTES

1—When describing the polarizations over the radiation sphere [definition (A)], or a portion of it, reference lines shall be specified over the sphere, in order to measure the tilt angles of the polarization ellipses [*see: tilt angle* (of a polarization ellipse)] and the direction of polarization for linear polarizations. An obvious choice, though by no means the only one, is a family of lines tangent at each point on the sphere to either the θ or ϕ coordinate line associated with a spherical coordinate system of the radiation sphere.

2—At each point on the radiation sphere, the polarization is usually resolved into a pair of orthogonal polarizations, the co-polarization and the cross polarization (*See: co-polarization; cross polarization*). To accomplish this, the co-polarization must be specified at each point on the radiation sphere. For certain linearly polarized antennas, it is common practice to define the co-polarization in the following manner: First specify the orientation of the co-polar electric field vector at a pole of the radiation sphere. Then, for all other directions of interest (points on the radiation sphere), require that the angle that the co-polar electric field vector makes with each great circle line through the pole remain constant over that circle, the angle being that at the pole. In practice, the axis of the antenna's main beam should be directed along the polar axis of the radiation sphere. The antenna is then appropriately oriented about this axis to align the direction of its polarization with that of the defined co-polarization at the pole. This manner of defining co-polarization can be extended to the case of elliptical polarization by defining the constant angles using the major axes of the polarization ellipses rather than the co-polar electric field vector. The sense of polarization must also be specified.

3—The polarization pattern [definition (B)] generally has the shape of a dumbbell. The polarization ellipse of the antenna in the given direction is similar to one that can be inscribed in the dumbbell shape with points of tangency at the maxima and minima points; thus, the axial ratio and tilt angle can be obtained from the polarization pattern.

2.287 polarization-phase vector (for a field vector). The polarization vector, among all of those that define the same polarization, that carries the phase information of the field vector whose polarization it represents. *See: polarization vector (for a field vector).*

NOTE—The polarization-phase vector of the field vector \vec{E} is given by $\vec{e} \equiv \vec{E}E$ where E is magnitude of \vec{E} that is, the positive square root of $\vec{E} * \vec{E}$.

2.288 polarization ratio. The magnitude of a complex polarization ratio.

2.289 polarization, receiving (of an antenna). The polarization of a plane wave, incident from a given direction and having a given power flux density, that results in maximum available power at the antenna terminals.

NOTES

1—The receiving polarization of an antenna is related to the antenna's polarization on transmit (see definition above) in the following way: In the same plane of polarization, the polarization ellipses have the same axial ratio, the same sense of polarization, and the same spatial orientation. Since their senses of polarization and spatial orientation are specified by viewing their polarization ellipses in the respective directions into which they are propagating, one should note that (a) although their senses of polarization are the same, they would appear to be opposite if both waves were viewed in the same direction; and (b) their tilt angles are such that they are the negative of one another with respect to a common reference.

2—The receiving polarization may be used to specify the polarization characteristic of a non-reciprocal antenna that may transmit and receive arbitrarily different polarizations.

2.290 polarization state (of a plane wave [field vector]). *See: state of polarization (of a plane wave [field vector]).*

2.291 polarization vector (for a field vector). A unitary vector that describes the state of polarization of a field vector at a given point in space.

NOTES

1—Polarization vectors differing only by a unitary factor ($e^{j\alpha}$ where α is real) correspond to the same polarization state.

2—The appropriate inner product, $\langle \hat{e}_1, \hat{e}_2 \rangle$, for two polarization vectors in the same planes of polarization is given by $\langle \hat{e}_1, \hat{e}_2 \rangle = \hat{e}_1^* \cdot \hat{e}_2$, where \hat{e}_1 and \hat{e}_2 represent the polarization vectors corresponding to polarizations 1 and 2.

3—The magnitude of the inner product of polarization vectors representing the same polarization is equal to unity. The inner product of two polarization vectors representing orthogonal polarization is zero.

4—The inner product of a polarization vector corresponding to a specified polarization, \hat{e}_1 and a complex electric field vector \vec{E} , at a point in space will yield the component of the electric field vector corresponding to the specified polarization, \vec{E}_1 ; that is, $\vec{E}_1 = (\hat{e}_1^* \cdot \vec{E})\hat{e}_1$.

5—The basis vectors for the components of the polarization vector may correspond to any two orthogonal polarizations, the most common being two orthogonal linear polarizations or right-hand and left-hand circular polarizations.

6—*Contrast with: polarization-phase vector (for a field vector).*

2.292 Potter horn. A circular horn with one or more abrupt changes in diameter that excites two or more waveguide modes in order to produce a specified aperture illumination.

2.293 power gain. [Deprecated.] *See: gain, partial (of an antenna).*

2.294 power pattern. *See: radiation pattern.*

2.295 power reflectance of a radome. At a given point on a radome, the ratio of the power flux density that is internally reflected from the radome to that incident on the radome from an internal radiating source.

2.296 power transmittance of a radome. In a given direction, the ratio of the power flux density emerging from a radome with an internal source to the power flux density that would be obtained if the radome were removed.

2.297 primary radiator. The radiating element of a reflector or lens antenna that is coupled to the transmitter or receiver directly, or through a feed line.

NOTE—For some applications, an array of radiating elements is employed.

2.298 principal E-plane. *See: E-plane, principal.*

2.299 principal half-power beamwidths. For a pattern whose major lobe has a half-power contour that is essentially elliptical, the half-power beamwidths in the two pattern cuts that contain the major and minor axes of the ellipse, respectively.

2.300 principal H-plane. *See: H-plane, principal.*

2.301 printed circuit antenna. An antenna of some desired shape bonded onto a dielectric substrate.

NOTE—The microstrip antenna is a notable example. *See: microstrip antenna.*

2.302 proximity-coupled dipole array antenna. An array antenna consisting of a series of coplanar dipoles, loosely coupled to the electromagnetic field of a balanced transmission line, the coupling being a function of the proximity and orientation of the dipole with respect to the transmission line.

2.303 pyramidal horn antenna. A horn antenna, the sides of which form a pyramid.

2.304 Q of a resonant antenna. The ratio of 2π times the energy stored in the fields excited by the antenna to the energy radiated and dissipated per cycle.

NOTE—For an electrically small antenna, it is numerically equal to one-half the magnitude of the ratio of the incremental change in impedance to the corresponding incremental change in frequency at resonance, divided by the ratio of the antenna resistance to the resonant frequency.

2.305 radar cross section. For a given scattering object, upon which a plane wave is incident, that portion of the scattering cross section corresponding to a specified polarization component of the scattered wave. *See: scattering cross section.*

2.306 radiating element. A basic subdivision of an antenna that in itself is capable of radiating or receiving radio waves.

NOTE—Typical examples of a radiating element are a slot, horn, or dipole antenna.

2.307 radiating near-field region. *See: near-field region, radiating.*

2.308 radiation efficiency. The ratio of the total power radiated by an antenna to the net power accepted by the antenna from the connected transmitter.

2.309 radiation, electromagnetic. The emission of electromagnetic energy from a finite region in the form of unguided waves.

2.310 radiation intensity. In a given direction, the power radiated from an antenna per unit solid angle.

2.311 radiation pattern. The spatial distribution of a quantity that characterizes the electromagnetic field generated by an antenna. *Syn: antenna pattern.*

NOTES

1—The distribution can be expressed as a mathematical function or as a graphical representation.

2—The quantities that are most often used to characterize the radiation from an antenna are proportional to, or equal to, power flux density, radiation intensity, directivity, phase, polarization, and field strength.

3—The spatial distribution over any surface or path is also an antenna pattern.

4—When the amplitude or relative amplitude of a specified component of the electric field vector is plotted graphically, it is called an **amplitude pattern, field pattern, or voltage pattern**. When the square of the amplitude or relative amplitude is plotted, it is called a **power pattern**.

5—When the quantity is not specified, an amplitude or power pattern is implied.

2.312 radiation pattern cut. Any path on a surface over which a radiation pattern is obtained.

NOTE—For far-field patterns, the surface is that of the radiation sphere. For this case, the path formed by the locus of points for which θ is a specified constant and ϕ is a variable is called a “conical cut.” The path formed by the locus of points for which ϕ is a specified constant and θ is a variable is called a “great circle cut.” The conical cut with θ equal to 90° is also a great circle cut. A spiral path that begins at the north pole ($\theta = 0^\circ$) and ends at the south pole ($\theta = 180^\circ$) is called a “spiral cut.”

2.313 radiation resistance. The ratio of the power radiated by an antenna to the square of the RMS antenna current referred to a specified point.

NOTES

1—The total power radiated is equal to the power accepted by the antenna minus the power dissipated in the antenna.

2—This term is of limited utility for antennas in lossy media.

2.314 radiation sphere (for a given antenna). A large sphere whose center lies within the volume of the antenna and whose surface lies in the far field of the antenna, over which quantities characterizing the radiation from the antenna are determined.

NOTES

1—The location of points on the sphere are given in terms of the θ and ϕ coordinates of a standard spherical coordinate system whose origin coincides with the center of the radiation sphere.

2—If the antenna has a spherical coordinate system associated with it, then it is desirable that its coordinate system coincide with that of the radiation sphere.

2.315 radiator. Any antenna or radiating element that is a discrete physical and functional entity.

2.316 radome. A cover, usually intended for protecting an antenna from the effects of its physical environment without degrading its electrical performance.

2.317 random array antenna. *See:* **array antenna.**

2.318 reactive field (of an antenna). Electric and magnetic fields surrounding an antenna and resulting in the storage of electromagnetic energy rather than in the radiation of electromagnetic energy.

2.319 reactive near-field region. *See:* **near-field region, reactive.**

2.320 reactive reflector antenna. *See:* **reflective array antenna.**

2.321 realized gain. The gain of an antenna reduced by the losses due to the mismatch of the antenna input impedance to a specified impedance.

NOTE—The realized gain does not include losses due to polarization mismatch between two antennas in a complete system.

2.322 realized gain, partial (of an antenna for a given polarization). The partial gain of an antenna for a given polarization reduced by the loss due to the mismatch of the antenna input impedance to a specified impedance.

2.323 receiving polarization (of an antenna). *See:* **polarization, receiving (of an antenna).**

2.324 rectangular array. [Deprecated.] *See:* **rectangular grid array.**

2.325 rectangular grid array. A regular arrangement of array elements, in a plane, such that lines connecting corresponding points of adjacent elements form rectangles.

2.326 reference boresight. A direction established as a reference for the alignment of an antenna. *See:* **electrical boresight.**

NOTE—The direction can be established by optical, electrical or mechanical means.

2.327 reference directivity. *See: standard directivity.*

2.328 reflective array antenna. An antenna consisting of a feed and an array of reflecting elements arranged on a surface and adjusted so that the reflected waves from the individual elements combine to produce a prescribed secondary pattern. *Syn: reactive reflector antenna.*

NOTE—The reflecting elements are usually waveguides containing electrical phase shifters and are terminated by short circuits.

2.329 reflector. *See: Cassegrain reflector antenna; corner reflector; cylindrical reflector; Gregorian reflector antenna; horn reflector antenna; main reflector; offset paraboloidal reflector antenna; parabolic torus antenna; paraboloidal reflector; reflector antenna; reflector element; spherical reflector; subreflector; toroidal reflector; umbrella reflector antenna.*

2.330 reflector antenna. An antenna consisting of one or more reflecting surfaces and a radiating [receiving] feed system.

NOTE—Specific reflector antennas often carry the name of the reflector used as part of the term used to specify it; for example, paraboloidal reflector antenna.

2.331 reflector element. A parasitic element located in a direction other than forward of the driven element of an antenna intended to increase the directivity of the antenna in the forward direction.

2.332 relative co-polar side lobe level. *See: co-polar side lobe, relative.*

2.333 relative cross-polar side lobe level. *See: cross-polar side lobe level, relative.*

2.334 relative gain (of an antenna). The ratio of the gain of an antenna in a given direction to the gain of a reference antenna.

NOTE—Unless otherwise specified, the maximum gains of the antennas are implied.

2.335 relative partial gain (of an antenna with respect to a reference antenna of a given polarization). In a given direction, the ratio of the partial gain of an antenna, corresponding to the polarization of the reference antenna, to the maximum gain of the reference antenna.

2.336 relative phase of an elliptically polarized field vector. *See: phase, relative, of an elliptically polarized field vector.*

2.337 relative side lobe level. *See: side lobe level, relative.*

2.338 resistance. *See: antenna resistance; radiation resistance.*

2.339 resonant frequency (of an antenna). A frequency at which the input impedance of an antenna is non-reactive.

2.340 retrodirective antenna. An antenna whose monostatic cross section is comparable to the product of its maximum directivity and its area projected in the direction toward the source, and is relatively independent of the source direction.

NOTE—Active devices can be added to enhance the return signal. For this case, the term shall be qualified by the word active; that is, active retrodirective antenna system.

2.341 rhombic antenna. An antenna composed of long wire radiators arranged in such a manner that they form the sides of a rhombus.

NOTE—The antenna usually is terminated in a resistance. The length of the sides of the rhombus, the angle between the sides, the elevation above ground, and the value of the termination resistance are proportioned to give the desired radiation properties.

2.342 ridged horn (antenna). A horn antenna in which the waveguide section is ridged.

2.343 right-hand polarization of a field vector. *See: sense of polarization.*

2.344 right-hand polarization of a plane wave. *See: sense of polarization.*

2.345 ring array. *See: circular array.*

2.346 scan angle. The angle between the direction of the maximum of the major lobe or a directional null and a reference direction. *Syn: beam angle.*

NOTES

1—The term *beam angle* applies to the case of a pencil beam antenna.

2—The reference boresight is usually chosen as the reference direction.

2.347 scanning (of an antenna beam). A repetitive motion given to the major lobe of an antenna.

2.348 scan sector. The angular interval over which the major lobe of an antenna is scanned.

2.349 scattering cross section. For a scattering object and an incident plane wave of a given frequency, polarization, and direction, an area that, when multiplied by the power flux density of the incident wave, would yield sufficient power that could produce, by isotropic radiation, the same radiation intensity as that in a given direction from the scattering object. *See: bistatic cross section; monostatic cross section; radar cross section.*

NOTE—The scattering cross section is equal to 4π times the ratio of the radiation intensity of the scattered wave in a specified direction to the power flux density of the incident plane wave.

2.350 secondary radiator. That portion of an antenna having the largest radiating aperture, consisting of a reflecting surface or a lens, as distinguished from its feed.

2.351 sectionalized [loaded] linear antenna. A linear antenna in which reactances are inserted at one or more points along the length of the antenna.

2.352 sector scanning. A modification of circular scanning in which the direction of the antenna beam generates a portion of a cone or a plane.

2.353 self-impedance (of an array element). The input impedance of a radiating element of an array antenna with all other elements in the array open-circuited.

2.354 self-phasing array antenna system. A receiving antenna system that introduces a phase distribution among the array elements so as to maximize the received signal, regardless of the direction of incidence. *Contrast with: retrodirective antenna.*

2.355 sense of polarization. For an elliptical or circularly polarized field vector, the sense of rotation of the extremity of the field vector when its origin is fixed.

NOTE—When the plane of polarization is viewed from a specified side, if the extremity of the field vector rotates clockwise [counterclockwise] the sense is right-handed [left-handed]. For a plane wave, the plane of polarization shall be viewed looking in the direction of propagation.

2.356 sequential lobing. A direction-determining technique utilizing the signals of partially overlapping lobes occurring in sequence.

2.357 series-fed vertical antenna. A vertical antenna that is insulated from ground and whose feed line connects between ground and the lower end of the antenna.

2.358 shaped-beam antenna. An antenna that is designed to have a prescribed pattern shape differing significantly from that obtained from a uniform-phase aperture of the same size.

2.359 shielded-loop antenna [probe]. An electrically small antenna consisting of a tubular electrostatic shield formed into a loop with a small gap, and containing one or more wire turns for external coupling.

2.360 shielded-loop probe. *See:* **shielded-loop antenna.**

2.361 shoulder lobe. A radiation lobe that has merged with the major lobe, thus causing the major lobe to have a distortion that is shoulder-like in appearance when displayed graphically. *Syn:* **vestigial lobe.**

2.362 shunt-fed vertical antenna. A vertical antenna that is connected directly to ground at its base and whose feed line connects to the antenna between ground and a point suitably positioned above the base.

2.363 side lobe. A radiation lobe in any direction other than that of the major lobe. *See:* **back lobe; co-polar side lobe level, relative; cross-polar side lobe level, relative; mean side lobe level; minor lobe; side lobe level, maximum relative; side lobe level, relative.**

2.364 side lobe level, maximum relative. The maximum relative directivity of the highest side lobe with respect to the maximum directivity of the antenna.

2.365 side lobe level, relative. The maximum relative directivity of a side lobe with respect to the maximum directivity of an antenna, usually expressed in decibels.

2.366 side lobe suppression. Any process, action, or adjustment to reduce the level of the side lobes or to reduce the degradation of the intended antenna system performance resulting from the presence of side lobes.

2.367 signal processing antenna system. An antenna system having circuit elements associated with its radiating element(s) that perform functions such as multiplication, storage, correlation, and time modulation of the input signals.

2.368 simultaneous lobing. A direction-determining technique utilizing the signals of overlapping lobes existing at the same time.

2.369 sleeve-dipole antenna. A dipole antenna surrounded in its central portion by a coaxial conducting sleeve.

2.370 sleeve-monopole antenna. An antenna consisting of half of a sleeve-dipole antenna projecting from a ground plane. *Syn:* **sleeve-stub antenna.**

2.371 sleeve-stub antenna. *See:* **sleeve-monopole antenna.**

2.372 slot antenna. A radiating element formed by a slot in a conducting surface.

2.373 solid-beam efficiency. The ratio of the power received over a specified solid angle when an antenna is illuminated isotropically by uncorrelated and unpolarized waves to the total power received by the antenna.

NOTE—This term is sometimes used to mean the ratio of the power received corresponding to a particular polarization over the solid angle to the total power received. Equivalently, the term is used to mean the ratio of the power radiated over a specified solid angle by the antenna corresponding to a particular polarization to the total power radiated.

2.374 space-tapered array antenna. An array antenna whose radiation pattern is shaped by varying the density of driven radiating elements over the array surface. *Syn:* **density-tapered array antenna.**

2.375 spherical array. A two-dimensional array of elements whose corresponding points lie on a spherical surface.

2.376 spherical reflector. A reflector that is a portion of a spherical surface.

2.377 spillover. In the transmit mode of a reflector antenna, the power from the feed that is not intercepted by the reflecting elements.

2.378 spiral antenna. An antenna consisting of one or more conducting wires or tapes arranged as a spiral.

NOTE—Spiral antennas are usually classified according to the shape of the surface to which they conform (for example, conical or planar spirals), and according to the mathematical form (for example, equiangular or archimedean).

2.379 squint. A condition in which a specified axis of an antenna, such as the direction of maximum directivity or of a directional null, departs slightly from a specified reference axis.

NOTES

1—Squint is often the undesired result of a defect in the antenna; but in certain cases, squint is intentionally designed in order to satisfy an operational requirement.

2—The reference axis is often taken to be the mechanically defined axis of the antenna; for example, the axis of a paraboloidal reflector.

2.380 squint angle. The angle between a specified axis of an antenna, such as the direction of maximum directivity or a directional null, and the corresponding reference axis.

2.381 standard [reference] directivity. The maximum directivity from a planar aperture of area A , or from a line source of length L , when excited with a uniform amplitude, equiphase distribution.

NOTES

1—For planar apertures in which $A \gg \lambda^2$. The value of the standard directivity is $4\pi A/\lambda^2$, with λ the wavelength and with radiation confined to a half space.

2—For line sources with $L \gg \lambda$, the value of the standard directivity is $2L/\lambda$.

2.382 standing-wave antenna. An antenna whose excitation is essentially equiphase, as the result of two feeding waves that traverse its length from opposite directions, their combined effect being that of a standing wave.

2.383 state of polarization (of a plane wave [field vector]). At a given point in space, the condition of the polarization of a plane wave [field vector] as described by the axial ratio, tilt angle, and sense of polarization. *Syn:* **polarization state (of a plane wave [field vector]).**

2.384 steerable-beam antenna system. An antenna with a non-moving aperture for which the direction of the major lobe can be changed by electronically altering the aperture excitation or by mechanically moving a feed of the antenna.

2.385 stepped antenna. *See: zoned antenna.*

2.386 stub antenna. A short, thick monopole.

2.387 subreflector. A reflector other than the main reflector of a multiple-reflector antenna.

2.388 sum pattern. A radiation pattern characterized by a single main lobe whose cross section is essentially elliptical, and a family of side lobes, the latter usually at a relatively low level.

NOTE—Antennas that produce sum patterns are often designed to produce a difference pattern and have application in acquisition and tracking radar systems. *Contrast with: difference pattern.*

2.389 superdirectivity. The condition that occurs when the antenna illumination efficiency significantly exceeds 100%.

NOTE—Superdirectivity is only obtained at a cost of a large increase in the ratio of average stored energy to energy radiated per cycle.

2.390 surface wave antenna. An antenna that radiates power from discontinuities in the structure that interrupt a bound wave on the antenna surface.

2.391 Taylor distribution, circular. A continuous distribution of a circular planar aperture that is equiphase, with the amplitude distribution dependent only on distance from the center of the aperture and such as to produce a pattern with a main beam plus side lobes. The side lobe structure is rotationally symmetric, with a specified number of inner side lobes at a quasi-uniform height, the remainder of the side lobes decaying in height with their angular separation from the main beam.

NOTE—Taylor distributions are often sampled to obtain the excitation for a planar array.

2.392 Taylor distribution, linear. A continuous distribution of a line source that is symmetric in amplitude, has a uniform progressive phase, and yields a pattern with a main beam plus side lobes. The side lobe structure is symmetrical, with a specified number of inner side lobes at a quasi-uniform height, the remainder of the side lobes decaying in height with their angular separation from the main beam.

NOTE—Taylor distributions are often sampled to obtain the excitation for a planar array.

2.393 thinned array antenna. An array antenna that contains substantially fewer driven radiating elements than a conventional uniformly spaced array with the same beamwidth having identical elements. Interelement spacings in the thinned array are chosen such that no large grating lobes are formed and side lobes are minimized.

2.394 tilt angle (of a polarization ellipse). When the plane of polarization is viewed from a specified side, the angle measured clockwise from a reference line to the major axis of the ellipse.

NOTES

1—For a plane wave, the plane of polarization shall be viewed looking in the direction of propagation.

2—The tilt angle is only defined up to a multiple of π radians and is usually taken in the range $(-\pi/2, +\pi/2)$ or $(0, \pi)$.

2.395 top-loaded vertical antenna. A vertical monopole with an additional metallic structure at the top intended to increase the effective height of the antenna and to change its input impedance.

2.396 toroidal reflector. A reflector formed by rotating a segment of plane curve about a nonintersecting coplanar line.

NOTE—The plane curve segment is called the torus cross section and the coplanar line is called the toroidal axis.

2.397 tracking. A motion given to the major lobe of an antenna with the intent that a selected moving target be contained within the major lobe. *Syn:* **angle tracking.**

2.398 traveling-wave antenna. An antenna whose excitation has a quasi-uniform progressive phase, as the result of a single feeding wave traversing its length in one direction only.

2.399 triangular array. [Deprecated.] *See:* **triangular grid array.**

2.400 triangular grid array. A regular arrangement of array elements, in a plane, such that lines connecting corresponding points of adjacent elements form triangles, usually equilateral.

2.401 turnstile antenna. An antenna composed of two dipole antennas, perpendicular to each other, with their axes intersecting at their midpoints. Usually, the currents on the two dipole antennas are equal and in phase quadrature.

2.402 two-dimensional scanning. Scanning the beam of a directive antenna using two degrees of freedom to provide solid angle coverage.

2.403 umbrella antenna. A type of top-loaded short vertical antenna in which the top-loading structure consists of elements sloping down toward the ground but not connected to it.

2.404 umbrella reflector antenna. An antenna constructed in a form similar to an umbrella that can be folded for storage or transport and unfolded to form a large reflector antenna for use.

2.405 uniform linear array. A linear array of identically oriented and equally spaced radiating elements having equal current amplitudes and equal phase increments between excitation currents.

2.406 V antenna. A V-shaped arrangement of two conductors, balanced-fed at the apex, with included angle, length, and apex height above the earth chosen so as to give the desired directive properties to the radiation pattern.

2.407 vertex plate (of a reflector antenna). A small auxiliary reflector placed in front of the main reflector near its vertex for the purpose of reducing the standing waves in the feed due to reflected waves from the main reflector.

2.408 vertically polarized field vector. A linearly polarized field vector whose direction is vertical.

2.409 vertically polarized plane wave. A plane wave whose electric field vector is vertically polarized.

2.410 vestigial lobe. *See:* **shoulder lobe.**

2.411 visible range. For the case in which the field pattern of a continuous line source, L_λ wavelengths long, is expressed as a function of ψ ($\psi = L_\lambda \cos \theta$, the angle θ is measured from an axis coincident with the line source), that part of the infinite range of ψ that corresponds to a variation in the directional angle θ from π to 0 radians; that is, $-L_\lambda < \psi < L_\lambda$.

NOTES

1—All values of ψ outside the visible range are said to be in the invisible range.

2—The formulation of the field pattern as a function of ψ is useful because the side lobes in the invisible range are a measure of the Q of the antenna.

3—This concept of a visible range can be extended to other antenna types.

2.412 voltage pattern. *See:* **radiation pattern.**

2.413 wave antenna. *See:* **Beverage antenna.**

2.414 whip antenna. A thin, flexible, monopole antenna.

2.415 wire antenna. An antenna composed of one or more conductors, each of which is long compared to the transverse dimensions, and with transverse dimensions of each conductor so small compared to a wavelength that for the purpose of computation the current can be assumed to flow entirely longitudinally and to have negligible circumferential variation.

2.416 wire-grid lens antenna. A lens antenna constructed of wire grids, in which the effective index of refraction (and thus the path delay) is locally controlled by the dimensions and the spacings of the wire grid. *Contrast with:* **geodesic lens antenna; Luneberg lens antenna.**

2.417 Wullenweber antenna. An antenna consisting of a circular array of radiating elements, each having its maximum directivity along the outward radial, and a feed system that provides a steerable beam that is narrow in the azimuth plane.

2.418 Yagi antenna. [Deprecated.] *See:* **Yagi-Uda antenna.**

2.419 Yagi-Uda antenna. A linear end-fire array consisting of a driven element, a reflector element, and one or more director elements.

2.420 zoned antenna. A lens or reflector antenna having various portions (called zones or steps) that form a discontinuous surface such that a desired phase distribution of the aperture illumination is achieved. *Syn:* **stepped antenna.**

2.421 zone-plate lens antenna. *See:* **Fresnel lens antenna.**