

---

# PROPOSED SMPTE STANDARD

**SMPTE 348M**

Revision of  
SMPTE 348M-2000

## for Television — High Data-Rate Serial Data Transport Interface (HD-SDTI)

---

Page 1 of 13 pages

### Table of contents

- 1 Scope
- 2 Normative references
- 3 General specifications
- 4 Header data specifications
- 5 Payload data formats

### 1 Scope

This standard provides the mechanisms necessary to facilitate the transport of packetized data over a synchronous data carrier. The HD-SDTI data packets and synchronizing signals provide a data transport interface which is compatible with SMPTE 292M (HD-SDI) such that it can be readily used by the infrastructure provided by this standard.

The standard uses a dual-channel operation where each line carries two data channels each forming an independent HD-SDTI data transport mechanism. The two channels are word-multiplexed onto the HD-SDI stream such that one line-channel occupies the C data space and the other line-channel occupies the Y data space.

The standard provides for a baseline operation which supports a constant payload length per line-channel having a maximum payload data rate up to approximately 1.0 Gb/s. It further provides for an extended operation which supports a variable payload length through the advancement of the SAV sequence to ensure a constant payload data rate regardless of the HD-SDI frame rate.

The HD-SDTI protocol is compatible with SMPTE 305.2M.

Additional documents shall be used to describe the payloads of particular applications of this standard including details of the data formatting and other parameters such as compression and error correction, if applicable.

#### Warning

This document is not a SMPTE Standard. It is distributed for review and comment. It is subject to change without notice and may not be referred to as a SMPTE Standard. Recipients of this document are invited to submit, with their comments, notification of any relevant patent rights of which they are aware and to provide supporting documentation. Distribution does not constitute publication.

## 2 Normative references

The following standards contain provisions which, through reference in this text, constitute provisions of this standard. At the time of publication, the editions indicated were valid. All standards are subject to revision, and parties to agreements based on this standard are encouraged to investigate the possibility of applying the most recent edition of the standards indicated below.

ANSI/SMPTE 125M-1995, Television — Component Video Signal 4:2:2 — Bit-Parallel Digital Interface

SMPTE 291M-1998, Television — Ancillary Data Packet and Space Formatting

SMPTE 292M-1998, Television — Bit-Serial Digital Interface for High-Definition Television Systems

SMPTE 299M-2004, Television — 24-Bit Digital Audio Format for SMPTE 292M Bit-Serial Interface

SMPTE 305.2M-2000, Television — Serial Data Transport Interface (SDTI)

ITU-T X.25 (10/96), Interface Between Data Terminal Equipment (DTE) and Data Circuit-Terminating Equipment (DCE) for Terminals Operating in the Packet Mode and Connected to Public Data Networks by Dedicated Circuit

## 3 General specifications

This standard describes the assembly of two channels of 10-bit words multiplexed onto one HD-SDI line for the purpose of transporting the data streams in a structured framework. The HD-SDTI data blocks and synchronizing signals provide a data transport protocol which can readily be added to the infrastructure provided by SMPTE 292M.

SMPTE 292M requires a sequence of 10-bit words which define a television horizontal line comprising five areas in the following sequence (note: the first 2 areas are often described together):

- EAV: a 4-word unique timing sequence defining the end of active video (of the previous line);
- LN/CRC: 2 words defining the line number followed by a 2-word CRC error detection code;
- Digital line blanking;
- SAV: a 4-word unique timing sequence defining the start of active video; and
- Digital active line.

An associated television source format standard defines the rate of television horizontal lines by defining the following parameters:

- The number of words per line;
- The number of words in the digital active line (and hence the number of words in the digital line blanking period);
- The number of lines per frame; and
- The number of frames per second.

SMPTE 292M currently defines 4 source format standards (1152, 1035, 1080, and 720 active lines per frame). ANSI/SMPTE 125M describes the meaning of the EAV and SAV word sequences which can be applied to all relevant source formats.

A decoder of this standard shall not be required to decode all the source formats available to SMPTE 292M. The source formats which must be supported by the decoder shall be specified in the application document.

### 3.1 HD-SDTI Mapping onto HD-SDI

The source format in combination with SMPTE 292M provide the bit-serial format formed from C/Y word-multiplexed channels as illustrated in figure 1.

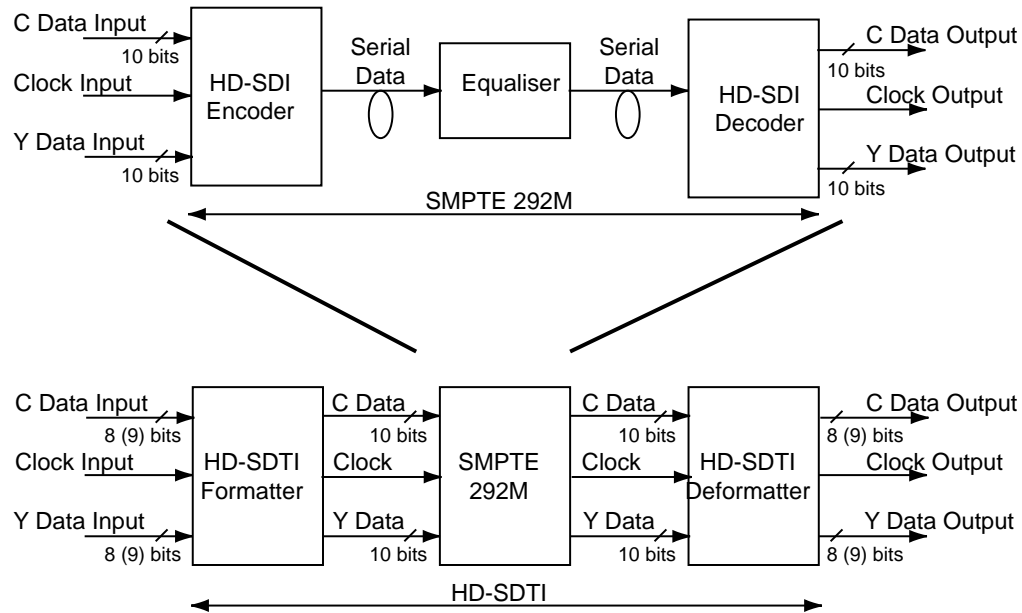

**Figure 1 – Arrangement of HD-SDTI wrapped around SMPTE 292M**

The HD-SDTI data shall be serialized, scrambled, coded, and interfaced according to SMPTE 292M and the associated source format standard. The signal specifications and connector types shall be as described in SMPTE 292M.

The data word length shall be 10 bits defined as bits B0 through to B9. B0 is the least significant bit (LSB) and B9 is the most significant bit (MSB). The order of bit-transmission shall be LSB first as defined in SMPTE 292M.

Source data shall be in groups of four 10-bit words representing a word-multiplexed  $C_B$ ,  $Y_1$ ,  $C_R$ ,  $Y_2$  signal, where  $C_B$  and  $C_R$  form one parallel C-data channel and  $Y_1$  and  $Y_2$  form a second parallel Y-data channel.

The C/Y word clock rate shall be exactly 74.25 MW/s for those picture rates which are an exact integer number per second and shall be  $74.25/1.001$  MW/s for those picture rates which are offset by a divisor of 1.001.

The bit clock rate shall be 20 times the C/Y word clock rate (i.e. 1.485 Gb/s or  $1.485/1.001$  Gb/s).

The timing reference signals, EAV and SAV, shall occur on every line and shall be C/Y interleaved as described in the source format document. The line number (LN) and CRC shall occur on every line and shall be C/Y interleaved as described in SMPTE 292M.

The HD-SDTI header data shall be encapsulated by an ancillary data packet according to SMPTE 291M and placed in the data space between the end of the EAV/LN/CRC and the beginning of the SAV.

The HD-SDTI payload shall be placed between the end of the SAV and the beginning of the EAV.

There shall be space for two HD-SDTI header data and payloads per line. The first HD-SDTI header data and payload shall use the C data channel and the second HD-SDTI header data and payload shall use the Y data channel. The two channels shall be word multiplexed according to SMPTE 292M.

Each C/Y multiplexed line is treated as a separate HD-SDTI payload. Any line may carry an HD-SDTI payload on either the C-channel or the Y-channel. Where a line carries both C-channel and Y-channel payloads, the C-channel payload shall be assumed first in time, followed by the Y-channel payload.

Figure 2 shows the data placement of the two HD-SDTI header data and payloads for one line.

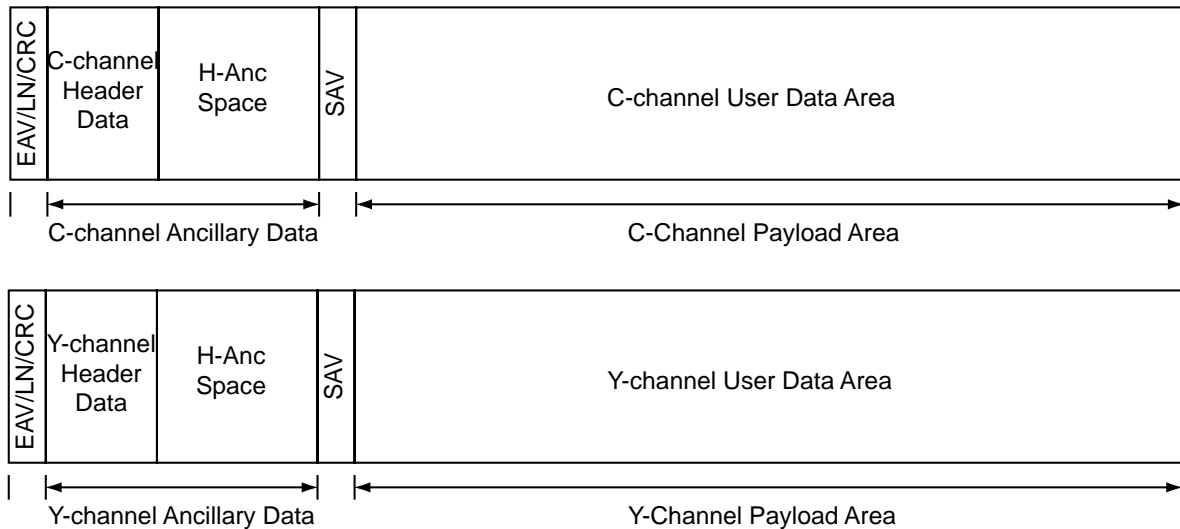

**Figure 2 – General layout of the dual-channel HD-SDTI header data and payload**

**3.2 Extended mode for constant payload data rate**

The default HD-SDTI payload for each channel is the defined C/Y digital active line- period for the source format at all picture rates. An optional extension mode allows source formats which would otherwise reduce the payload data rate, to advance the timing of the SAV marker so that the payload data rate remains a constant value. In extended mode, the constant payload data rate value is either exactly 129.6 MB/s or 129.6/1.001 MB/s depending on whether the frame rate of the source format includes a 1.001 divisor. The payload length values associated with particular source formats are given in table 1.

**Table 1 – Payload length extension values for varying source frame rates**

Frame rate	Total lines per frame	Samples per line	Blanking length	Payload length	Gross (Y+C) payload rate
25	1125	2640	336	2304	129.6 MB/s
24 (24/1.001)	1125	2750	350	2400	129.6 MB/s
60 (60/1.001)	750	1650	210	1440	129.6 MB/s
50	750	1980	252	1728	129.6 MB/s
30 (30/1.001)	750	3300	420	2880	129.6 MB/s
25	750	3960	504	3456	129.6 MB/s
24 (24/1.001)	750	4125	525	3600	129.6 MB/s

## NOTES

- 1 Not all equipment may support the extended mode. Users are cautioned to check whether advancement of the SAV is supported by the HD-SDI infrastructure and the HD-SDTI decoder.
- 2 Table 1 does not include the default frame rates of 30 Hz and 30/1.001 Hz for 1125 line interfaces as these offer the gross payload rate without changing the digital active line period.

### 3.3 Double-rate operation

The source format may allow frequencies of double the baseline rate to accommodate the carriage of progressively scan pictures at the rates of 50 Hz, 60/1.001 Hz, and 60 Hz for some source formats.

The use of double-rate sampling frequencies is allowed within this standard as a specified extension. The effect is a doubling of the number of line-channels per second and there is no effect on the data structure within each line-channel save doubling of the clock rates.

This is a significant extension of the source format capability and only specified equipment may support this operation. Users are cautioned to check whether double clock rate is supported by the HD-SDI infrastructure and the HD-SDTI decoder.

## 4 Header data specifications

For each line-channel carrying an HD-SDTI payload, HD-SDTI header data shall be encapsulated by an ancillary data packet conforming to a SMPTE 291M ancillary data packet structure (type 2) as shown in table 2.

**Table 2 – HD-SDTI ancillary data packet structure**

Name	Acronym	Value
Ancillary data flag (10-bit words)	ADF	000 <sub>h</sub> , 3FF <sub>h</sub> , 3FF <sub>h</sub>
Data identification	DID	40 <sub>h</sub>
Secondary data identification	SDID	02 <sub>h</sub>
Data count	DC	2A <sub>h</sub>
HD-SDTI header data	42 words	—
Check sum	CS	—

The total size of the ancillary data packet shall be 49 words of which the HD-SDTI header data comprises the 42 words as shown in table 3. The structure of the HD-SDTI header data packet is further described in figure 3.

**Table 3 – HD-SDTI header data**

Name	Word length
Code and AAI	1 word
Destination address	16 words
Source address	16 words
Block type	1 word
CRC flag	1 word
Data extension flag	1 word
Reserved data	4 words
Header CRC	2 words

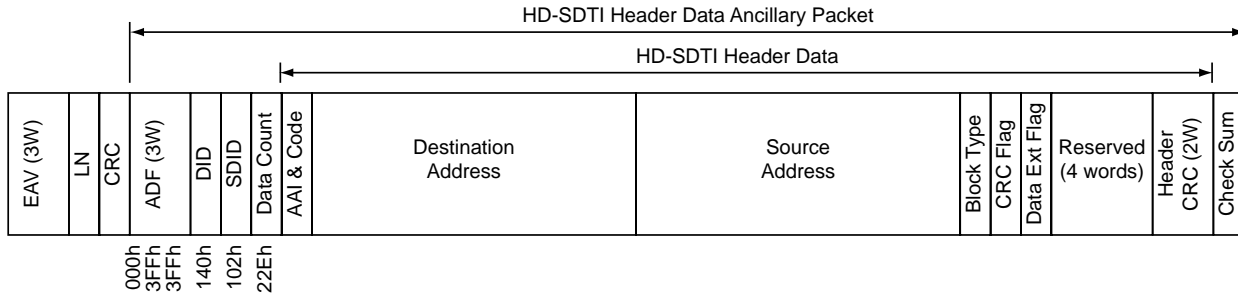

**Figure 3 – Header data structure**

HD-SDTI header data shall be located immediately after the EAV/LN/CRC sequence as shown in figure 3 on lines specified in the application document. In the special case of HD-SDTI applications which embed digital audio according to SMPTE 299M, the HD-SDTI header data packets shall be placed immediately following any such SMPTE 299M ancillary data packets.

For line-channels which do not carry an HD-SDTI payload, the “block type” (section 4.4) shall be set to a value of “00<sub>h</sub>” to indicate a null payload. (plus definition of other header data).

All data in the HD-SDTI header data shall use 8-bit words using bits B0 to B7 of each word. For all words of the HD-SDTI header data, bit B8 shall be the even parity of bits B0 to B7 and bit B9 shall be the complement of bit B8.

**4.1 Ancillary data formatting**

The ADF, DID, SDID, DC and CS data words shall conform to SMPTE 291M. All data in the ancillary packet following the ADF shall be 8 bit words where the word value is defined by bits B7 through B0. Bit B8 is even parity of bits B7 through B0 and bit B9 is the complement of bit B8.

**4.1.1 Data ID (DID)**

The data ID shall have the value [40<sub>h</sub>] for bits B7 through B0.

**4.1.2 Secondary data ID (SDID)**

The secondary data ID shall have the value [01<sub>h</sub>] for bits B7 through B0.

**4.1.3 Data count (DC)**

The data count shall represent 42 words for the header and have the value [2A<sub>h</sub>] for bits B7 through B0.

**4.2 AAI (Authorized address identifier) and code**

Both AAI and code shall consist of 4 bits (see figure 4). AAI shall comprise bits B7 to B4. Code shall comprise bits B3 to B0.

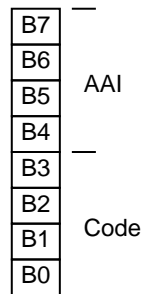

**Figure 4 – Assignment of AAI and code bits**

#### 4.2.1 AAI

The AAI shall identify the format of both the destination and source address words from one of 16 different states.

**Table 4 – Assignment of payload size**

Address identification	B7	B6	B5	B4
Unspecified format	0	0	0	0
IP-v6 addressing	0	0	0	1

The value [0<sub>h</sub>] is reserved for applications where no source and destination address format is specified. In this case, any non-zero value in the source and destination address shall be ignored.

#### 4.2.2 Code

“Code” shall identify the length of the payload which shall be contained in the area between the SAV and EAV timing reference points.

**Table 5 – Assignment of payload size**

Payload	Bits:	B3	B2	B1	B0
SDI		0	0	0	0
1440 words		0	0	0	1
1920 words		0	0	1	0
1280 words		0	0	1	1
Reserved for 143Mb/s applications		1	0	0	0
2304 words (extension mode)		1	0	0	1
2400 words (extension mode)		1	0	1	0
1440 words (extension mode)		1	0	1	1
1728 words (extension mode)		1	1	0	0
2880 words (extension mode)		1	1	0	1
3456 words (extension mode)		1	1	1	0
3600 words (extension mode)		1	1	1	1
Reserved but not defined		All other codes			

The value [0<sub>h</sub>] is reserved to carry a line of SDI signal in the digital active line area.

The code values higher than [8h] shall only be used if the HD-SDTI is being used in extended mode with support for advanced SAV positioning as detailed in table 1.

**4.3 Destination and source address**

The destination and source address represents the address of the devices within the connection according to the AAI.

Sixteen bytes are allocated for both destination and source address with the bit allocation for each address as shown in figure 5.

A7	A15	A23	A31	A39	A47	A55	A63	A71	A79	A87	A95	A103	A111	A119	A127
A6	A14	A22	A30	A38	A46	A54	A62	A70	A78	A86	A94	A102	A110	A118	A126
A5	A13	A21	A29	A37	A45	A53	A61	A69	A77	A85	A93	A101	A109	A117	A125
A4	A12	A20	A28	A36	A44	A52	A60	A68	A76	A84	A92	A100	A108	A116	A124
A3	A11	A19	A27	A35	A43	A51	A59	A67	A75	A83	A91	A99	A107	A115	A123
A2	A10	A18	A26	A34	A42	A50	A58	A66	A74	A82	A90	A98	A106	A114	A122
A1	A9	A17	A25	A33	A41	A49	A57	A65	A73	A81	A89	A97	A105	A113	A121
A0	A8	A16	A24	A32	A40	A48	A56	A64	A72	A80	A88	A96	A104	A112	A120

**Figure 5 – Assignment of bits for the source and destination addresses**

The default condition when no destination and source address is required is that all 16 bytes of the destination and source addresses shall be set to “00h” in accordance with AAI = “0h”. When all 16 bytes of the destination address are zero filled in accordance with AAI = “0h”, it shall indicate a universal address to all destination devices connected to the interface.

**4.4 Block type**

The block type shall consist of one word comprising bits B7 to B0. The block type shall define the segmentation of the payload. Either fixed block size or variable block size may be defined.

A block type value of “00h” shall be used to indicate that the payload area does not contain an HD-SDTI payload.

**4.4.1 Fixed block type**

B7 and B6 form the prefix to define the fixed block data structure as follows:

	B7	B6
Fixed block size without ECC:	0	0
Fixed block size with ECC:	0	1

Where the fixed block includes ECC, the ECC is contained within the fixed block data and the type of ECC shall be defined by the application.

The possible segmentation of the fixed block size and the values for bits B5 to B0 are shown in table 6.

The first fixed block shall start immediately following the last word of the SAV for the line-channel. Where more than one fixed block is present on a line-channel, the fixed blocks shall form a contiguous string. Any space between the end of the last fixed block and first word of the EAV shall be filled with the value “200h”.



**Table 6 – Payload segmentation for fixed blocks**

Block type	Block size		Block type	Block size
01 <sub>h</sub>	1438 words		2A <sub>h</sub>	193 words
02 <sub>h</sub>	719 words		2B <sub>h</sub>	57 words
03 <sub>h</sub>	479 words		2C <sub>h</sub>	385 words
04 <sub>h</sub>	359 words		2D <sub>h</sub>	513 words
09 <sub>h</sub>	1918 words		2E <sub>h</sub>	609 words
0A <sub>h</sub>	959 words		31 <sub>h</sub>	62 words
0B <sub>h</sub>	639 words		32 <sub>h</sub>	153 words
11 <sub>h</sub>	766 words		33 <sub>h</sub>	171 words
12 <sub>h</sub>	383 words		34 <sub>h</sub>	177 words
13 <sub>h</sub>	255 words		35 <sub>h</sub>	199 words
14 <sub>h</sub>	191 words		36 <sub>h</sub>	256 words
21 <sub>h</sub>	5 words		37 <sub>h</sub>	144 words
22 <sub>h</sub>	9 words		38 <sub>h</sub>	160 words
23 <sub>h</sub>	13 words		39 <sub>h</sub>	1278 words
24 <sub>h</sub>	17 words		3A <sub>h</sub>	1726 words
25 <sub>h</sub>	33 words		3B <sub>h</sub>	2302 words
26 <sub>h</sub>	49 words		3C <sub>h</sub>	2398 words
27 <sub>h</sub>	65 words		3D <sub>h</sub>	2878 words
28 <sub>h</sub>	97 words		3E <sub>h</sub>	3454 words
29 <sub>h</sub>	129 words		3F <sub>h</sub>	3598 words

#### 4.4.2 Variable block type

The presence of a variable block size on the payload line-channel shall be indicated by the value [C1<sub>h</sub>]. Thus bits B7 and B6 are set to “1” to easily define the presence of a variable block.

With a variable block, any size of consecutive block data words are permitted and the variable block may extend beyond the length of one line-channel.

Where the variable block occupies more than one line-channel, the line-channels used shall be contiguous and header data shall be repeated for all line-channels associated with the variable block. The line-channels shall be considered as part of the contiguous sequence of a variable block with the C-channel of any line preceding the Y-channel.

#### 4.5 Payload CRC flag

The payload CRC flag shall consist of one word provided only for compatibility with SMPTE 305.2M. This word is redundant in HD-SDTI because the CRC words of each EAV sequence are calculated from the first word of the payload to the last word of the LN number.

The payload CRC flag word shall be set to [00<sub>h</sub>]. All other values are reserved but not defined.

#### 4.6 Data extension flag

The data extension flag shall consist of one word comprising bits B7 to B0.

The data extension flag shall be used to indicate whether there are extension data packets loaded in the space following the header data and before the SAV.

The values of the data extension word are:

- [00h]: No extension data packet
- [01h] – [FFh]: Reserved but not defined

The data extension flag is provided for compatibility with SMPTE 305.2M. This standard does not recommend the active use of this flag and the only valid value shall be [00h].

#### 4.7 Header expansion reserved data

The header expansion reserved data shall be positioned after the data extension flag. The default value for the four reserved data words shall be [00h].

#### 4.8 Header CRC

The header CRC shall be inserted following each ancillary data header. The header CRC applies to all 10 bits of each word, starting with the DID word through to the last reserved data word.

The generator polynomial for the header CRC shall be:

$$G(X) = X^{18} \oplus X^5 \oplus X^4 \oplus 1, \text{ which conforms to ITU-T X.25 (see figure 7).}$$

The header CRC shall be contained in bits C17 through C0 as defined in figure 6, and the initial value shall be set to [3FFh][3FFh].

C7	C15
C6	C14
C5	C13
C4	C12
C3	C11
C2	C10
C1	C9
C0	C8

Figure 6 – Header CRC bit definitions

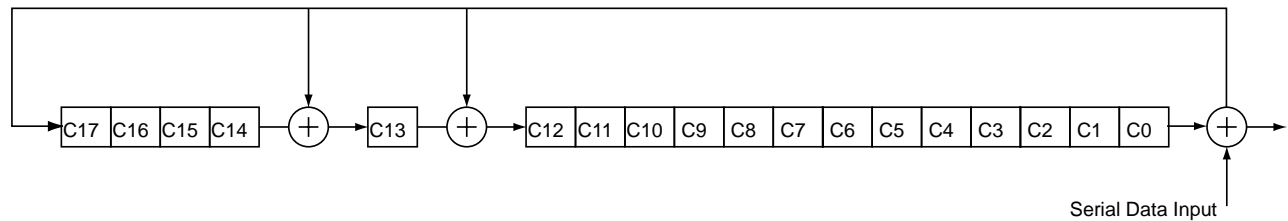

Figure 7 – CRC generator polynomial block diagram

## 5 Payload data formats

HD-SDTI payload data may be present on any line-channel from the end of SAV to the beginning of EAV. Some applications may constrain the use of certain line-channels.

Although data may exist on any line it should be noted that data may be corrupted during a switch.

### 5.1 Payload bit assignment

The payload data shall consist of either:

- a) 8-bit words contained in bits B7 to B0 with bit B8 set to be even parity of bits B7 to B0.
- b) 9-bit words contained in bits B8 to B0.

The application shall define whether 8-bit or 9-bit inputs are used. This standard recommends that applications use 8-bit input mode unless clear reasons for using the 9-bit input mode can be provided. The 9-bit mode is provided primarily for backwards compatibility with SMPTE 305.2M.

In all cases, bit B9 of each payload data word shall be set to the complement of bit B8 with the exception of the separator and end-code words of variable blocks.

### 5.2 Data type

The data type shall consist of one 8-bit word contained in bits B7 to B0 for both fixed and variable blocks. The data type identifies the type of data contained in the data block and shall have the same assignment of payload data type as defined in table 1 of SMPTE 305.2M.

### 5.3 Fixed block data structure

The fixed block data structure shall be as defined in figure 8 comprising of a 1-byte data type word followed by the data block.

The data type word shall identify the type of data contained in the data block. The length of each data block shall be identified by block type value contained in the header data and defined by the length indicated in table 6.

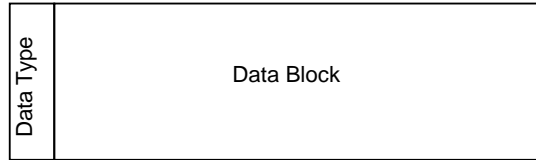

**Figure 8 – Data structure for fixed blocks**

**5.4 Variable block data structure**

The variable block data structure shall be as defined in figure 9. It shall comprise a 1-word separator, followed by a 1-byte data type word, a 4-byte word count, the data block and terminating in a 1-word end-code.



**Figure 9 – Data structure for variable blocks**

If a variable block exceeds the length of one line-channel, the data shall continue over succeeding line-channels until the end of the block. All line-channels carrying a part of the same variable block shall ensure that the header data is consistent over the duration of the variable block.

It is recommended that each and every variable block starts on a new line immediately following the SAV.

Any space between the end code word of a variable block and either the start of a new variable block or the first word of the EAV on the same line shall be filled with the value “200<sub>h</sub>”.

**5.4.1 Separator and end-code**

Each variable block shall start with a 1-word separator and end with a 1-word end-code. The values of separator and end-code shall be 10-bit words as follows.

	B9	B8	B7	B6	B5	B4	B3	B2	B1	B0
Separator, [309h]:	1	1	0	0	0	0	1	0	0	1
End-code, [30Ah]:	1	1	0	0	0	0	1	0	1	0

Note that bit B9 of the separator and end-codes is not the complement of bit B8. These two codes are registered values which break the normal HD-SDTI rules in order to guarantee their unique value and hence provide unambiguous start and stop codes for each variable block.

**5.4.2 Word-count**

The word-count shall consist of four words as shown in figure 10. The word-count shall be used to represent the number of words in the data block.

C7	C15	C23	C31
C6	C14	C22	C30
C5	C13	C21	C29
C4	C12	C20	C28
C3	C11	C19	C27
C2	C10	C18	C26
C1	C9	C17	C25
C0	C8	C16	C24

**Figure 10 – Bit assignment of the variable block word-count**

The word-count shall be contained in bits C31 through C0, and shall be interpreted as a single 32-bit unsigned integer with C31 as the MSB.

A word-count value of [00h][00h][00h][00h] shall be used to indicate either a variable block of unknown length or a variable block whose length exceeds that of the word-count capability. In such a case, the completion of a variable block is defined only by the reception of an end-code word.

It is the intent of this standard that all receiving equipment should attempt to receive data in a variable block even if the word-count has a zero value.