PROPOSED SMPTE STANDARD

SMPTE 398M

for Digital Video Recording — 1/2-in Type D-14 Component Format — 525/60 and 625/50

Page 1 of 83 pages

Table of contents

- 1 Scope
- 2 Normative references
- 3 Environment and test conditions
- 4 Video tape
- 5 Helical recordings
- 6 Program track data
- 7 Video interface
- 8 Audio data interface
- 9 Video processing
- 10 Audio data processing
- 11 Longitudinal track
- Annex A Tape tension
- Annex B Cross-tape track measurement technique
- Annex C Track pattern during insert editing
- Annex D Recorder block diagram contained in this document
- Annex E Reference and calibration tape
- Annex F Tape cassette
- Annex G Abbreviations
- Annex H Bibliography

1 Scope

This standard specifies the content, format, and recording method of the data blocks containing video, audio, and associated data which form the helical records on 12.65-mm (0.5-in) tape. In addition, this standard specifies the content, format, and recording method of the longitudinal record containing tracking information for the scanning head associated with the helical records, and also the longitudinal cue audio, and time and control code tracks.

One video channel and eight independent AES3 audio data channels¹⁾ are recorded in the digital format. Each of these AES3 data channels is designed to be capable of independent editing.

NOTE 1 – Throughout the text of this standard, the expression “AES3 audio data” shall be abbreviated to “audio data” and represents digitized audio and data in AES-3 format.

The video channel records and reproduces a component television signal in the 525-line system with a frame frequency of 29.97 Hz (hereafter referred to as the 525/60 system) and the 625-line system with a frame frequency of 25.00 Hz (hereafter referred to as the 625/50 system).

Figures 1 and 2 show block diagrams of typical recording and playback circuits.

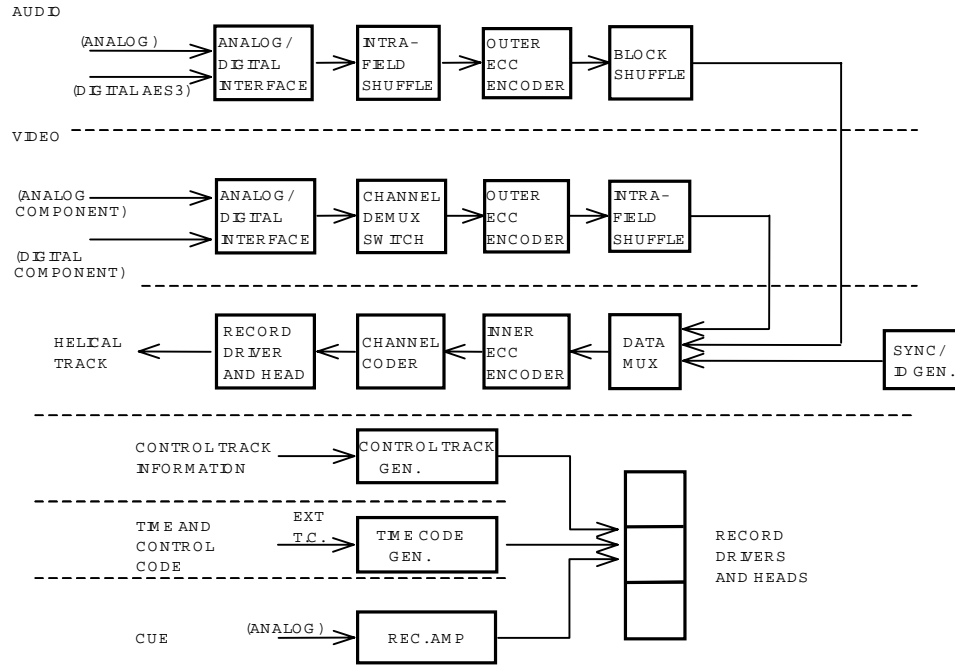

Figure 1 – Record block diagram

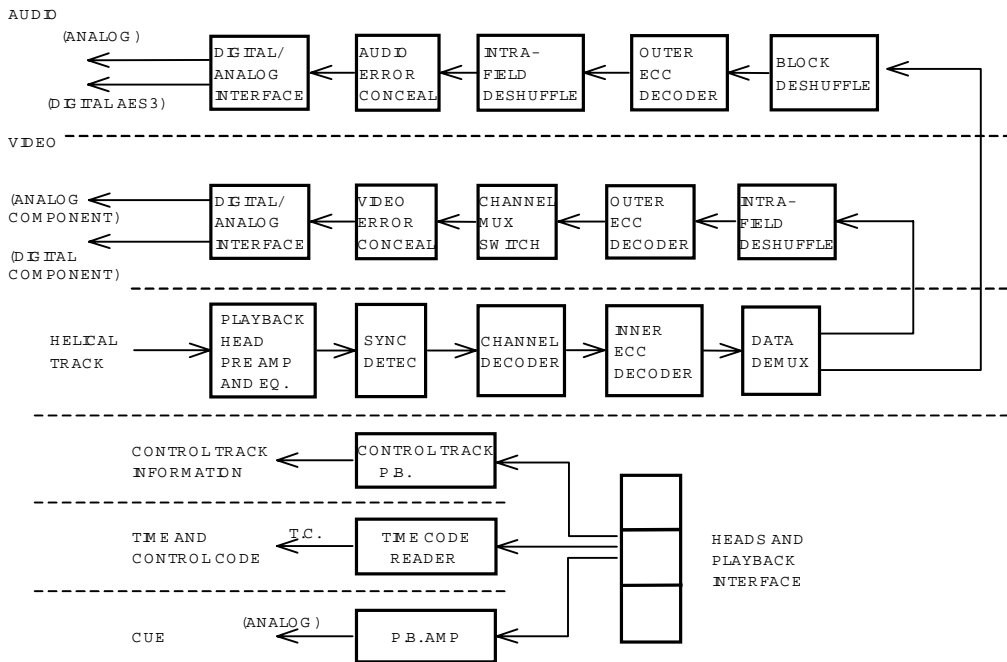

Figure 2 – Playback block diagram

2 Normative references

The following standards contain provisions, which through reference in this text, constitute provisions of this standard. At the time of publication, the editions indicated were valid. All standards are subject to revision, and parties to agreements based on this standard are encouraged to investigate the possibility of applying the most recent edition of the standards indicated below.

ANSI/SMPTE 125M-1995, Television — Component Video Signal 4:2:2 — Bit-Parallel Digital Interface

ANSI/SMPTE 259M-1997, Television — 10-Bit 4:2:2 Component and 4fsc Composite Digital Signals — Serial Digital Interface

ANSI/SMPTE 272M-1994, Television — Formatting AES/EBU Audio and Auxiliary Data into Digital Video Ancillary Data Space

SMPTE 12M-1999, Television, Audio and Film — Time and Control Code

SMPTE RP 155-1997, Audio Levels for Digital Audio Records on Digital Television Tape Recorders

AES3-1992 (R1997), Serial Transmission Format for two Channel Linearly Represented Digital Audio Data

3 Environment and test conditions

3.1 Environment

Tests and measurements made on the system to check the requirements of this standard shall be carried out under the following conditions:

- Temperature $20\text{ °C} \pm 1\text{ °C}$
- Relative humidity $(50 \pm 2)\%$
- Barometric pressure from 86 kPa to 106 kPa
- Tape conditioning not less than 24 h
- Center tape tension $0.31\text{ N} \pm 0.05\text{ N}$ (see annex A)

4 Magnetic tape

4.1 Base

The base material shall be polyester or equivalent.

4.2 Width

The tape width shall be $12.650\text{ mm} \pm 0.008\text{ mm}$. The tape, covered with glass, shall be measured without tension at a minimum of five different positions along the tape using a calibrated comparator having an accuracy of 0.001 mm ($1\text{ }\mu\text{m}$). The tape width is defined as the average of the five readings.

4.3 Width fluctuation

Tape width fluctuation shall not exceed $5\text{ }\mu\text{m}$ peak to peak. Measurement of tape width fluctuation shall be taken over a tape length of 900 mm. The value of tape width fluctuation shall be evaluated by measuring the tape width at 10 points, each separated by a distance of 100 mm.

4.4 Tape thickness

Two types of tape thickness shall be permitted by this standard. The first tape thickness shall be 10.2 μm to 11.0 μm (referred to as 11 μm); the second tape thickness shall be 13.0 μm to 14.0 μm (referred to as 14 μm).

4.5 Transmissivity

Transmissivity shall be less than 5%, measured over the range of wavelengths 800 nm to 900 nm.

4.6 Offset yield strength

The offset yield strength shall be greater than 9 N for 11- μm tape and 10 N for 14- μm tape. The force to produce 0.2 % elongation of a 1000-mm test sample with a pull rate of a 10-mm per minute shall be used to confirm the offset yield strength. The line beginning at 0.2 % elongation parallel to the initial tangential slope is drawn and then read at the point of intersection of the line and the stress-strain curve.

4.7 Magnetic coating

The magnetic layer of the tape shall consist of a coating of metal particles or equivalent.

4.8 Coating coercivity

The coating coercivity shall be a class 1800 (144000 A/m) with an applied field of 400000 A/m (5000 Oe) as measured by a 50-Hz or 60-Hz B-H meter or vibrating sample magnetometer (VSM).

4.9 Particle orientation

The metal particles shall be longitudinally oriented.

5 Helical recordings

5.1 Tape speed

The tape speed shall be 167.228 mm/s (525/60 system) and 185.995 mm/s (625/50 system). The tolerance shall be $\pm 0.2\%$.

5.2 Record location and dimensions

5.2.1 The format requires a full track width erasure for continuous recording and a flying erasure for insert editing.

5.2.2 Record location and dimensions for continuous recording shall be as specified in figures 3 and 4 and tables 1 (525/60 system) and 2 (625/50 system). In recording, sector locations on each helical track shall be contained within the tolerances specified in figure 3 and tables 1 (525/60 system) and 2 (625/50 system).

5.2.3 The reference edge of the tape for dimensions specified in this standard shall be the lower edge as shown in figure 3. The magnetic coating, with the direction of tape travel as shown in figure 3, is on the side facing the observer (measuring techniques are shown in annex B).

5.2.4 As indicated in figure 3, this standard anticipates a zero guard band between recorded tracks, and the record head width should be equivalent to the track pitch of 20 μm . The scanner head configuration should be chosen such that the recorded track widths are contained within the limits of 18 μm to 22 μm .

5.2.5 In insert editing, this standard provides a guard band of 2 μm (nominal) between the previously recorded track and the inserted track at editing points only. A typical track pattern for insert editing is shown in figure C.1 of annex C.

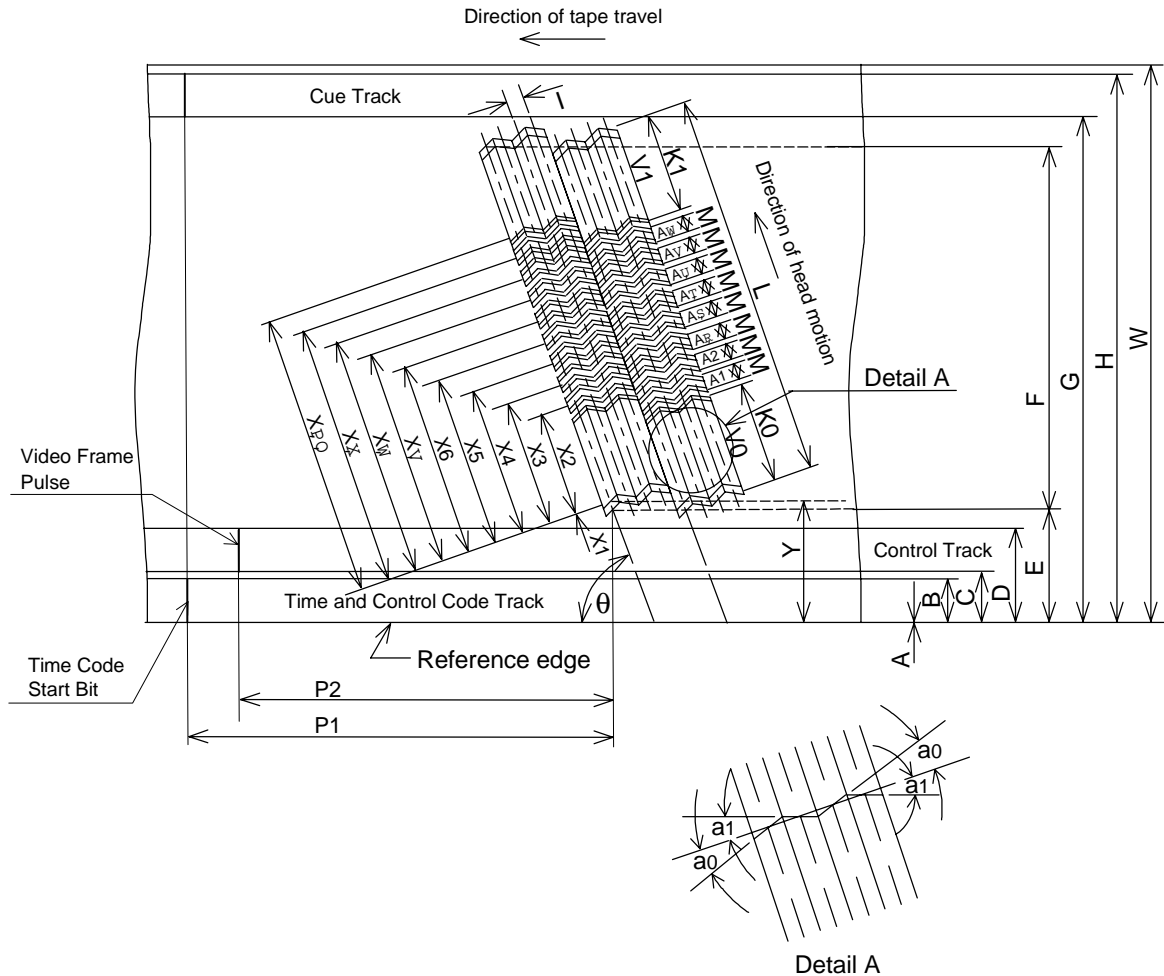

NOTES

- 1 A1 to A8 are audio data sectors.
- 2 V0 and V1 are video sectors.
- 3 Tape viewed from magnetic coating side.
- 4 Dimensions X1 to X10 are determined by the program reference point as defined in figure 4.

Figure 3 – Location and dimensions* of recorded tracks
(See tables 1 and 2)

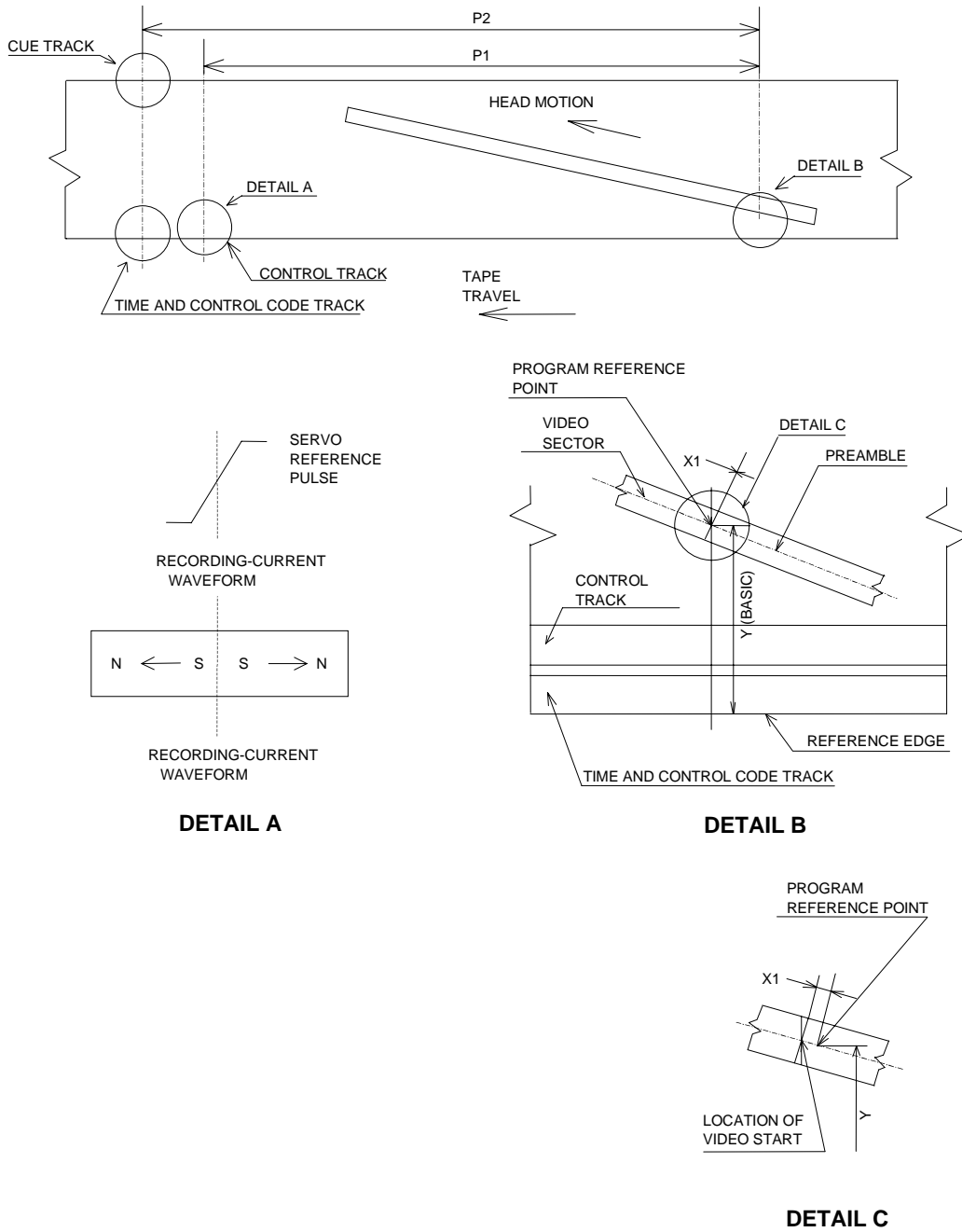

Figure 4 – Location of cue and time and control code track records

Table 1 – Record location and dimensions (525/60 system)

Dimensions		Nominal	Tolerance
A	Time and control code track lower edge	0	Basic
B	Time and control code track upper edge	0.450	± 0.050
C	Control track lower edge	0.900	± 0.050
D	Control track upper edge	1.300	± 0.050
E	Program area lower edge	1.629	Derived
F	Program area width	10.020	Derived
G	Cue audio track lower edge	11.950	± 0.050
H	Cue audio track upper edge	12.550	± 0.050
I	Helical track pitch	0.0200	Ref
K0	Video sector 0 length	51.624	Derived
K1	Video sector 1 length	51.562	Derived
L	Helical track total length	116.397	Derived
M	Audio data sector length	1.273	Derived
P1	Control track reference pulse to program reference point (see figure 4)	180.556	± 0.050
P2	Cue/time and control code signal, start of code word, to program reference point (see figure 4)	183.407	± 0.100
X1	Location of start of video sector V0	0	± 0.050
X2	Location of start of audio data sector A1	51.898	± 0.050
X3	Location of start of audio data sector A2	53.507	± 0.050
X4	Location of start of audio data sector A3	55.117	± 0.050
X5	Location of start of audio data sector A4	56.726	± 0.050
X6	Location of start of audio data sector A5	58.335	± 0.050
X7	Location of start of audio data sector A6	59.944	± 0.050
X8	Location of start of audio data sector A7	61.554	± 0.050
X9	Location of start of audio data sector A8	63.163	± 0.050
X10	Location of start of video sector V1	64.772	± 0.050
Y	Program reference point	1.639	Basic
θ	Track angle	4.9384 °	Basic
a0	Azimuth angle (track 0)	- 20.038 °	± 0.150 °
a1	Azimuth angle (track 1)	19.962 °	± 0.150 °
NOTES			
1 Measurements shall be made under the conditions specified in 3.1. The measurements shall be corrected to account for actual tape speed (see figures B.1 and B.2).			
2 All dimensions in millimeters.			

Table 2 – Record location and dimensions (625/50 system)

Dimensions		Nominal	Tolerance
A	Time and control code track lower edge	0	Basic
B	Time and control code track upper edge	0.450	± 0.050
C	Control track lower edge	0.900	± 0.050
D	Control track upper edge	1.300	± 0.050
E	Program area lower edge	1.745	Derived
F	Program area width	9.911	Derived
G	Cue audio track lower edge	11.950	± 0.050
H	Cue audio track upper edge	12.550	± 0.050
I	Helical track pitch	0.0200	Ref
K0	Video sector 0 length	52.104	Derived
K1	Video sector 1 length	52.034	Derived
L	Helical track total length	115.131	Derived
M	Audio data sector length	1.089	Derived
P1	Control track reference pulse to program reference point (see figure 4)	179.277	± 0.050
P2	Cue/time and control code signal, start of code word, to program reference point (see figure 4)	182.666	± 0.100
X1	Location of start of video sector V0	0	± 0.050
X2	Location of start of audio data sector A1	52.228	± 0.050
X3	Location of start of audio data sector A2	53.631	± 0.050
X4	Location of start of audio data sector A3	54.973	± 0.050
X5	Location of start of audio data sector A4	56.315	± 0.050
X6	Location of start of audio data sector A5	57.658	± 0.050
X7	Location of start of audio data sector A6	59.000	± 0.050
X8	Location of start of audio data sector A7	60.342	± 0.050
X9	Location of start of audio data sector A8	61.685	± 0.050
X10	Location of start of video sector V1	63.027	± 0.050
Y	Program reference point	1.756	Basic
θ	Track angle	4.9384 °	Basic
a0	Azimuth angle (track 0)	- 20.038 °	± 0.150 °
a1	Azimuth angle (track 1)	19.962 °	± 0.150 °
NOTES			
1 Measurements shall be made under the conditions specified in 3.1. The measurements shall be corrected to account for actual tape speed (see figures B.1 and B.2).			
2 All dimensions in millimeters.			

5.3 Helical track record tolerance zones

The lower edges of any eight consecutive tracks starting at the first track in each video frame shall be contained within the pattern of the eight tolerance zones established in figure 5. Each zone is defined by two parallel lines, which are inclined at an angle of 4.9384° (basic) with respect to the tape reference edge.

The centerlines of all zones shall be spaced apart 0.0200 mm (basic). The width of zones 1 to 3 and 5 to 8 shall be 0.006 mm (basic). The width of zone 4 shall be 0.004 mm (basic). These zones are established to contain track angle errors, track straightness errors, and vertical head offset tolerance (measuring technique is shown in annex B).

5.4 Relative positions of recorded information

5.4.1 Relative positions of longitudinal tracks

Audio data, Video, control track, time and control code, and cue track with information intended to be time coincident shall be positioned as shown in figures 3 and 4.

5.4.2 Program area reference point

The program area reference point is determined by the intersection of a line parallel to the reference edge of the tape at a distance Y from the reference edge and the centerline of the first track in each video field (segment 0, track 0). (See figures 3 and 4.)

The end of the preamble and start of the video sector shall be recorded at the program area reference point, and the tolerance is dimension X1. The locations are shown in figures 3 and 4; dimensions X1 and Y are in tables 1 and 2. The relationship between sectors and contents of each sector is specified in clause 6.

5.5 Gap azimuth

5.5.1 Cue track, control track, time code track

The azimuth angle of the cue, control track, and time and control code head gaps used to produce longitudinal track records shall be perpendicular to the track record.

5.5.2 Helical track

The azimuth of the head gaps used for the helical track shall be inclined at angles a_0 and a_1 as specified in tables 1 and 2, with respect to a line perpendicular to the helical track. The azimuth of the first track of every field (segment 0, track 0) shall be oriented in the counterclockwise direction with respect to a line perpendicular to the helical track direction when viewed from the side of the tape containing the magnetic record.

5.6 Transport and scanner (informative)

The effective drum diameter, tape tension, helix angle, and tape speed taken together determine the track angle. Different methods of design and/or variations in drum diameter and tape tension can produce equivalent recordings for interchange purposes.

One possible configuration of the transport uses a scanner with an effective diameter of 76.000 mm. Scanner rotation is in the same direction as tape motion during normal playback mode. Data are recorded by two groups of four heads mounted 180° apart. Figure 6 shows one possible mechanical configuration of the scanner, and table 3 shows the corresponding mechanical parameters. Figure 7 shows the relationship between the longitudinal heads and the scanner.

Other mechanical configurations are allowable provided the same footprint of recorded information is produced on tape.

Erase heads are illustrated in annex C.

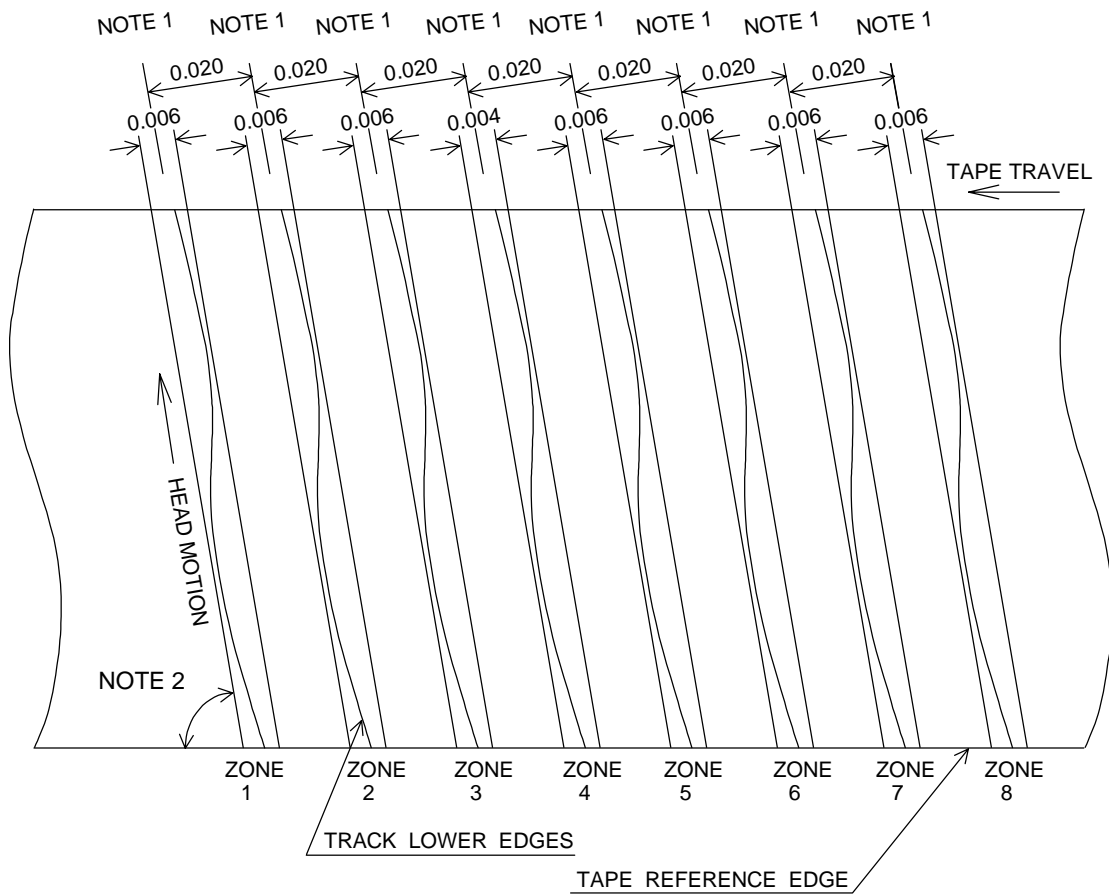

NOTES

- 1 Tolerance zone centerlines.
- 2 4.9384°.
- 3 All dimensions in millimeters.

Figure 5 – Location and dimensions of tolerance zones of helical track record

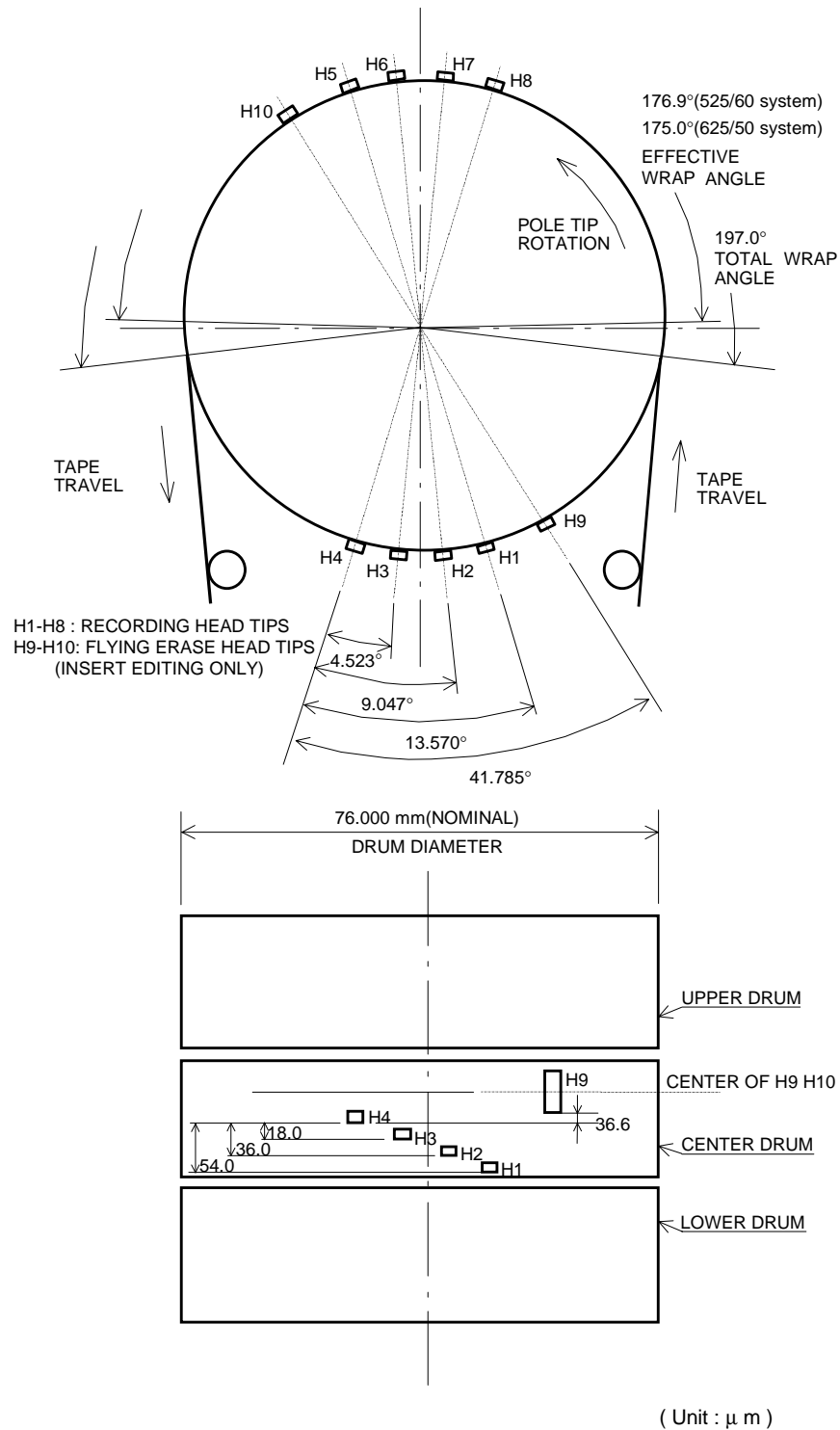
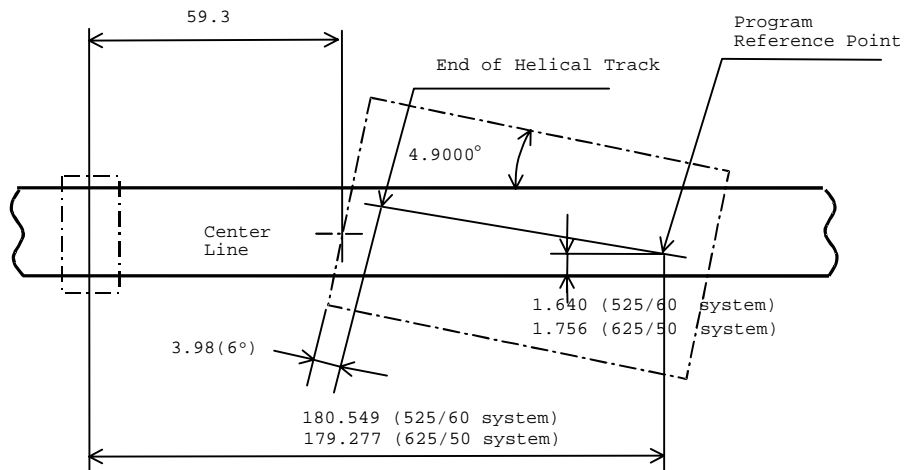
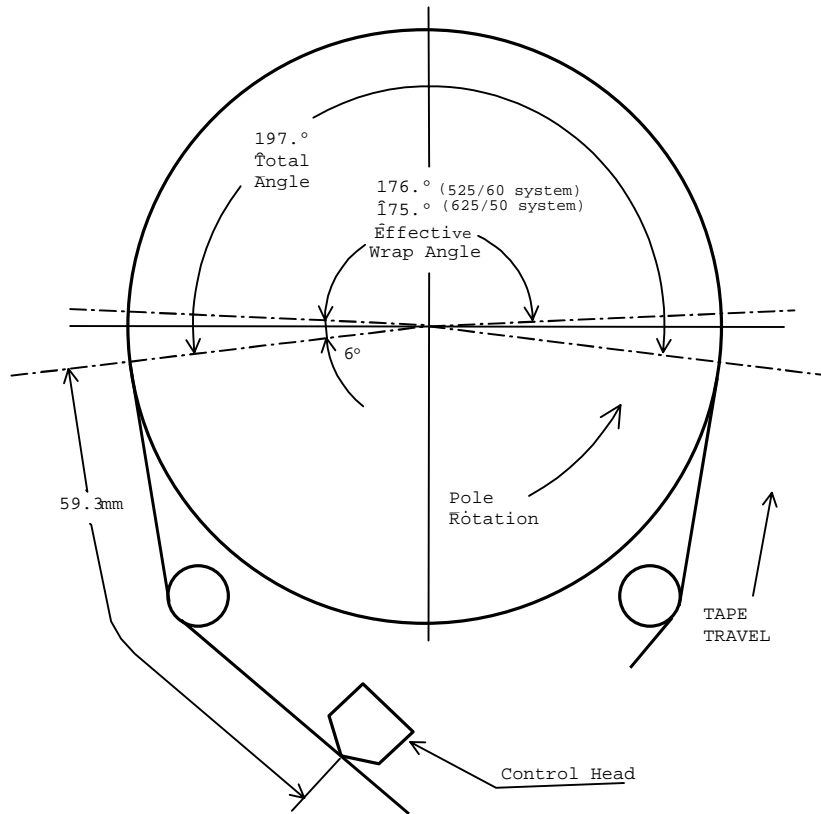

Figure 6 – Possible scanner configuration

Table 3 – Parameters for a possible scanner design

Parameters	525/60 system	625/50 system
Scanner rotation speed (rps)	90/1.001	100
Number of tracks per rotation	8	
Drum diameter (mm)	76.000	
Centre span tension (N)	0.31	
Helix angle (degrees)	4.9000	
Effective wrap angle (degrees)	176.9	175.0
Scanner circumferential speed (m/s)	21.5	23.9
H1,H5 overwrap head entrance (degrees)	14.1	16.0
H1,H5 overwrap head exit (degrees)	6	
Angular relationship (degrees) H1 - H4 : H2 - H4 : H3 - H4 : H5 - H8 : H6 - H8 : H7 - H8 : H4 - H8 :	13.570 9.047 4.523 13.570 9.047 4.523 180.000	
Vertical displacement (mm) H1 - H4 : H2 - H4 : H3 - H4 : H5 - H8 : H6 - H8 : H7 - H8 :	0.054 0.036 0.018 0.054 0.036 0.018	
Maximum tip projection (µm) Note: Head projection from a drum surface	42.0	
Record head track width (µm) NOTE – Track edit points are excluded	20	

TOP VIEW



NOTE - Unwrapped, viewed magnetic coating side

Figure 7 – Possible longitudinal head location and tape wrap

6 Program track data

6.1 Introduction

Each television field is recorded on 12 tracks (525/60 system) or 16 tracks (625/50 system).

The helical tracks contain digital data from the video channel and eight audio data channels. Each track contains a video sector followed by eight audio data sectors corresponding to eight audio data channels and followed by a second video sector, recorded in that order. An edit gap between sectors accommodates timing errors during editing. Figure 8 shows the arrangement of video and audio data sectors on the tape.

6.2 Labeling convention

The least significant bit is written on the left and is the first recorded to tape. The lowest numbered byte is shown at the left/top and is the first encountered in the input data stream.

Byte values are expressed in hexadecimal notation unless otherwise noted. An h subscript indicates a hexadecimal value.

6.3 Sector details

Each sector (audio data or video) is divided into the following elements:

- Preamble containing clock run-up sequence, sync pattern, identification pattern and fill pattern;
- Sync blocks containing sync pattern and identification pattern, followed by a fixed length data block with error control;
- Postamble containing sync pattern and identification pattern.

6.3.1 Sync block

The sync block format is common to both audio data and video sectors. Each sync block contains a sync pattern (2 bytes) and an inner code block. Each inner block contains an identification pattern (2 bytes) and 85 (525/60 system) or 76 (625/50 system) data bytes of video, audio data, or outer check bytes followed by 8 inner check bytes.

The inner code block protects the two bytes of the identification pattern together with 85 data bytes (525/60 system) or 76 data bytes (625/50 system). Figures 9 (525/60 system) and 10 (625/50 system) show the sync block format.

6.3.2 Sync pattern

a) Length: 16 bits (2 bytes).

b) Pattern: 97F1 (in hexadecimal notation).

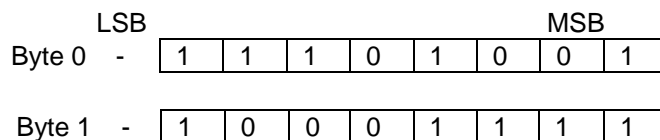

c) Protection: None.

d) Randomization: None.

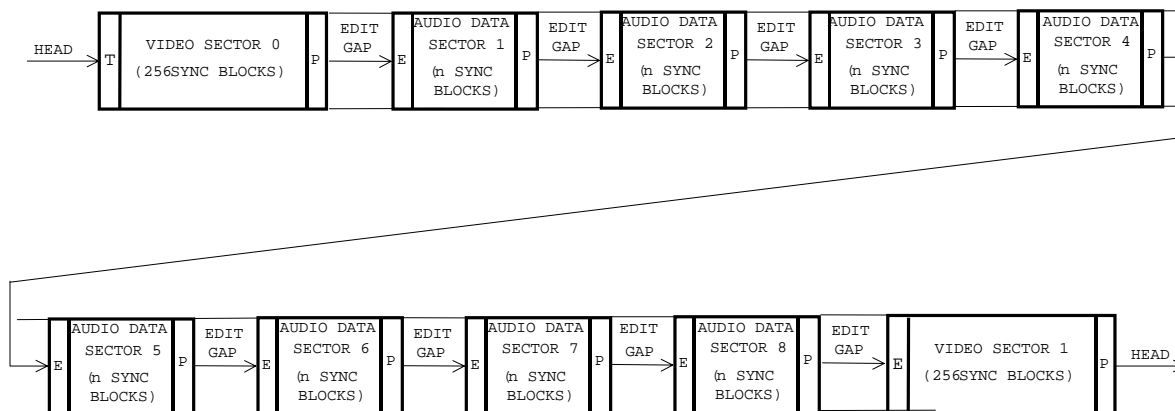

NOTES

- 1 T = Track preamble (58 bytes).
- 2 E = In-track preamble (28 bytes).
- 3 P = Postamble (4 bytes).
- 4 Sync block: 97 bytes (525/60 system), 88 bytes (625/50 system).
- 5 Edit gap: 162 bytes nominal (525/60 system), 144 bytes nominal (625/50 system).
- 6 Sync blocks in audio sector n=6 (525/60 system), 5 (625/50 system).

Figure 8 – Sector arrangement on helical track

6.3.3 Identification pattern

As illustrated in figures 11 (525/60 system) and 12 (625/50 system), the first two bytes of each inner block are used for identification of sync block, segment (group of helical tracks scanned simultaneously), helical track number, television field, and sector (portion of a track). Bits 1 to 6 of the second byte (byte 3 of sync block) of the identification pattern identify the track. Bit 7 of the second byte (byte 3) identifies a sector on the helical track (see figures 13 and 14).

a) Length: 16 bits (2 bytes).

b) Arrangement: The sync block number (byte 2 and bit 0 of byte 3) follows a coded sequence along the track. Figures 15 and 16 show the sequence of the sync block numbers.

The sector ID (bits 1-7 of byte 3) identifies a particular sector.

The segment number is modulo 3 (525/60 system) or modulo 4 (625/50 system). For the 525/60 system, the field number for video sectors is modulo 4 ($VF_2 = 0$ in byte 3). The field number for audio data sectors is modulo 4 (for AF_0 and AF_1 in byte 3) and AF_2 (in byte 3) is used for the identification of the five field sequences. For the 625/50 system, the field number for video sectors is modulo 8 and the field number for audio data sectors is modulo 4 ($AF_2 = 0$).

c) Video field identification: The field address VF_0 , VF_1 , VF_2 (bits 4, 5, and 6 of byte 3) for video sync blocks shall identify the field sequence as shown below:

i) In the case of component recording, at the time of the start of each recording, the start of color frame sequence counter is indicated by the field address bits VF_0 , VF_1 , VF_2 these bits are set to zero. This point is coincident with field 1 of an arbitrary chosen frame for 525/60 or 625/50 component system.

ii) In the case of component signal derived from an optional composite signal input, the field address shall identify the four-field color sequences (525/60 system) or eight-field color sequences (625/50 system), as defined in ITU Report 624 and have the values of the field address set as shown below:

525/60 system:

Component signal input	Composite signal input	VF_0	VF_1	VF_2
Field 1	Color frame A, field I	0	0	0
Field 2	Color frame A, field II	1	0	0
Field 1	Color frame B, field III	0	1	0
Field 2	Color frame B, field IV	1	1	0

625/50 system:

Component signal input	Composite signal input	VF_0	VF_1	VF_2
Field 1	Color field I	0	0	0
Field 2	Color field II	1	0	0
Field 1	Color field III	0	1	0
Field 2	Color field IV	1	1	0
Field 1	Color field V	0	0	1
Field 2	Color field VI	1	0	1
Field 1	Color field VII	0	1	1
Field 2	Color field VIII	1	1	1

d) Audio data field identification: The field address AF_0 and AF_1 of the audio data sync block (bits 4 and 5 of byte 3) shall identify a four-field sequence as shown below. The sequence shall be identical for the 525/60 system and the 625/50 system. When audio data sectors are edited, the four-field sequence shall be maintained.

Field	AF_0	AF_1
m	0	0
m+1	1	0
m+2	0	1
m+3	1	1

For the 525/60 system, the field address AF_2 of the audio data sync block (bit 6 of byte 3) shall identify a five-field sequence for the number of audio data samples in the current field as shown below. When audio data sectors are edited, the five-field sequence shall be maintained (see 10.3.6 d). For the 625/50 system, the field address AF_2 of the audio data sync block (bit 6 of byte 3) shall be set always to 0.

525/60 system			625/50 system	
Field	AF_2	Number of audio data samples	AF_2	Number of audio data samples
n	0	801	0	960
n+1	0	801	0	960
n+2	0	801	0	960
n+3	0	801	0	960
n+4	1	800	0	960

e) Protection: The identification pattern is protected by an inner code block.

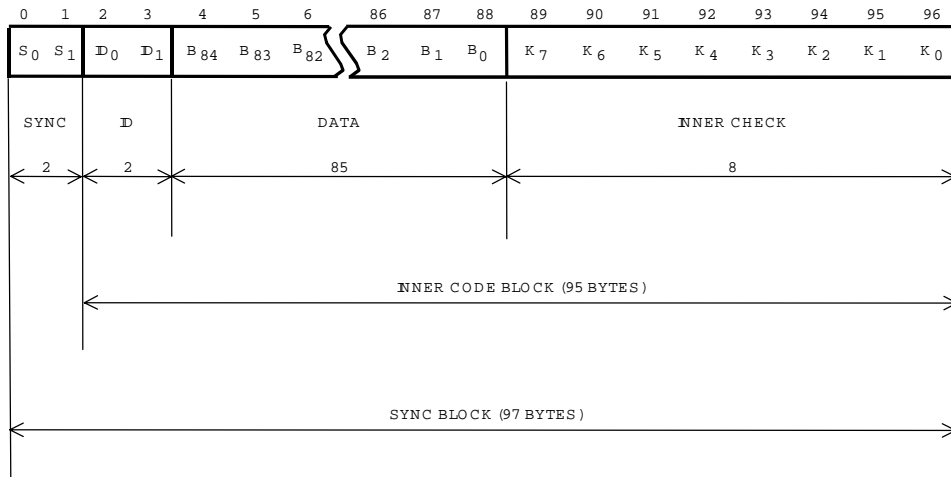

Figure 9 – Sync block format (525/60 system)

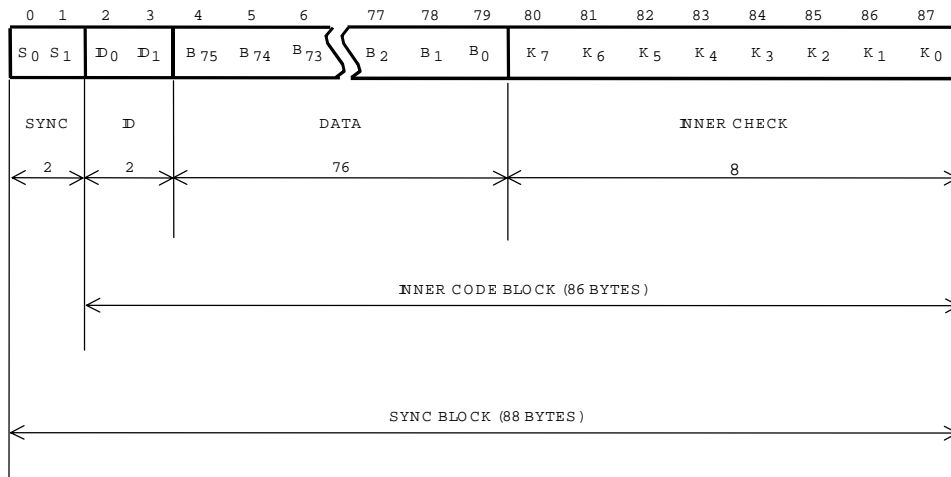
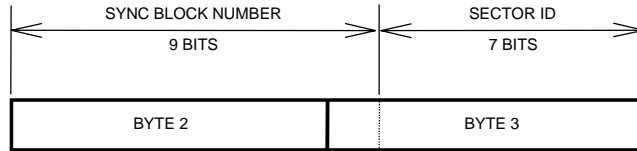

Figure 10 – Sync block format (625/50 system)

ARRANGEMENT



SYNC BLOCK NUMBER

BYTE 2

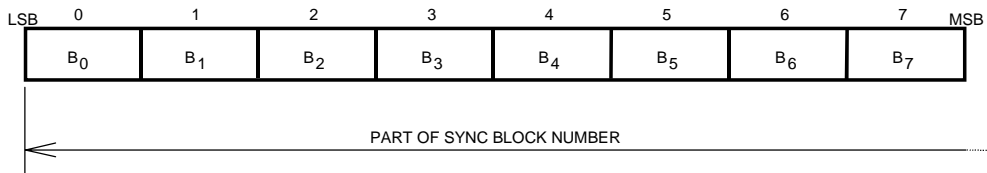

SECTOR ID FOR VIDEO SYNC BLOCKS

BYTE 3

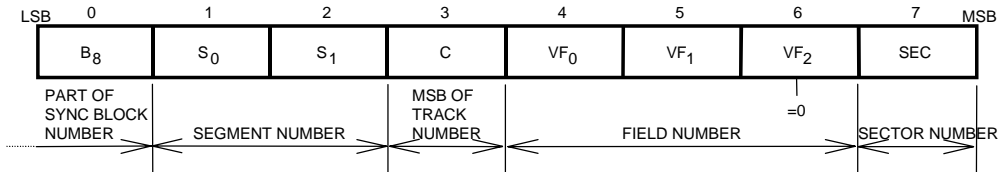

SECTOR ID FOR AUDIO SYNC BLOCKS

BYTE 3

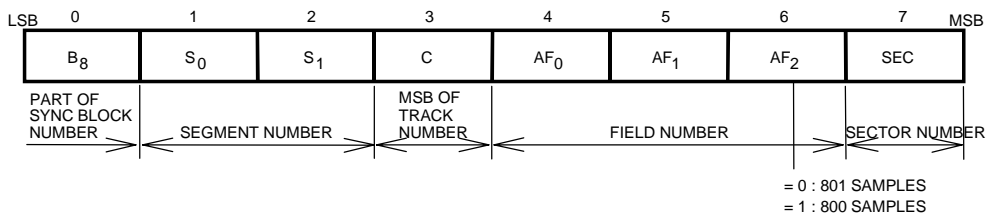
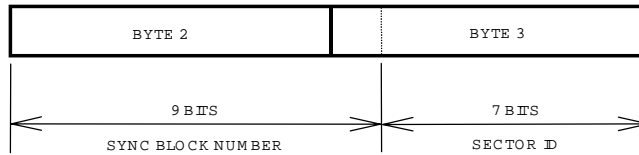
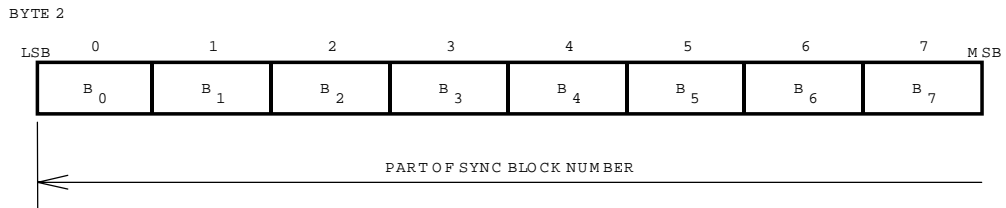

Figure 11 – Sync block identification format (525/60 system)

ARRANGEMENT



SYNC BLOCK NUMBER



SECTOR ID FOR VIDEO SYNC BLOCKS

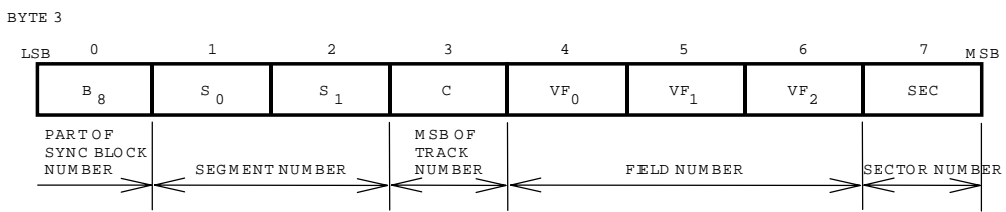

SECTOR ID FOR AUDIO SYNC BLOCKS

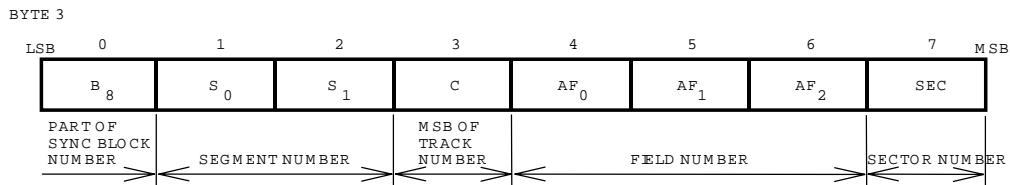
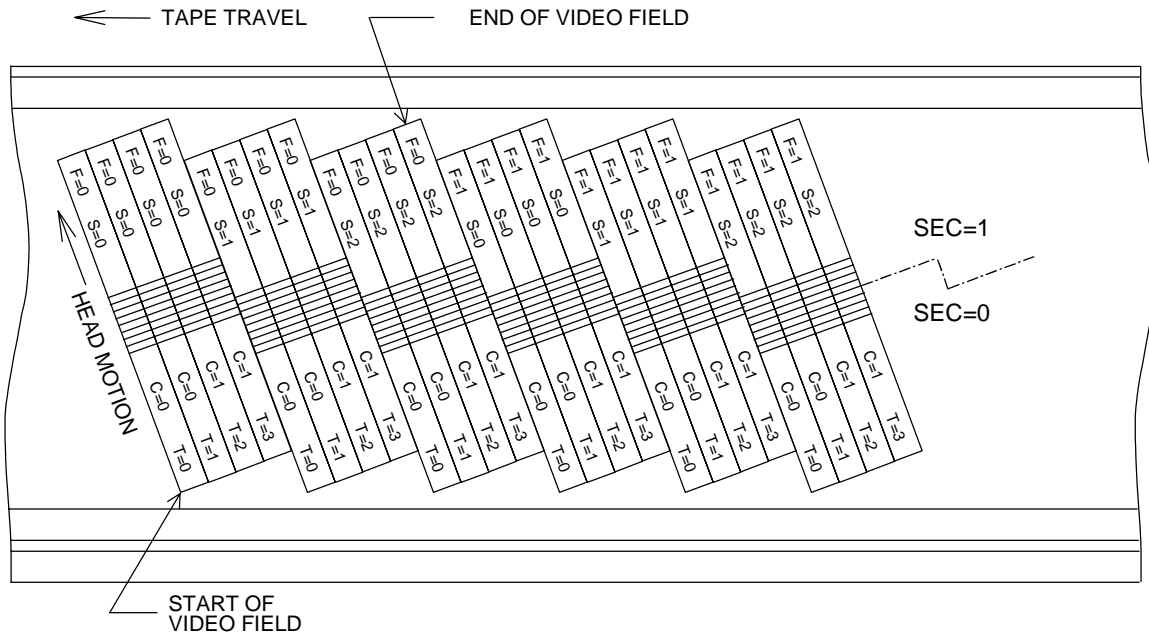

Figure 12 – Sync block identification format (625/50 system)



NOTES

- 1 F = field number (0, 1, 2, 3). (see Note in section 6.3.3.c)
- 2 S = segment number (0, 1, 2).
- 3 SEC = sector number; C = MSB of track number (0, 1).
- 4 T = track number (0, 1, 2, 3). LSB of track number is identified by the azimuth angle.
- 5 Audio data sectors are not shown.

Figure 13 – Track, segment and field numbers (525/60 system)

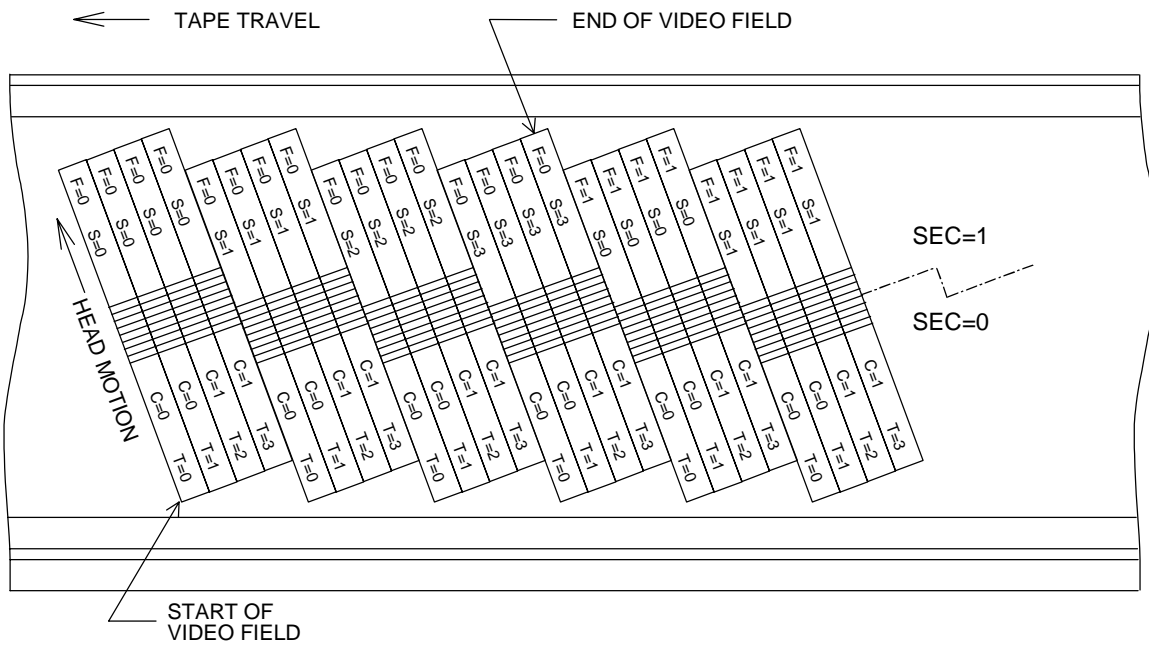

NOTES

- 1 F = field number (0, 1, 2, 3 . . . 7). (see Note in section 6.3.3.c)
- 2 S = segment number (0, 1, 2, 3).
- 3 SEC = sector number; C = MSB of track number (0, 1).
- 4 T = track number (0, 1, 2, 3). LSB of track number is identified by the azimuth angle.
- 5 Audio data sectors are not shown.

Figure 14 – Track, segment and field numbers (625/50 system)

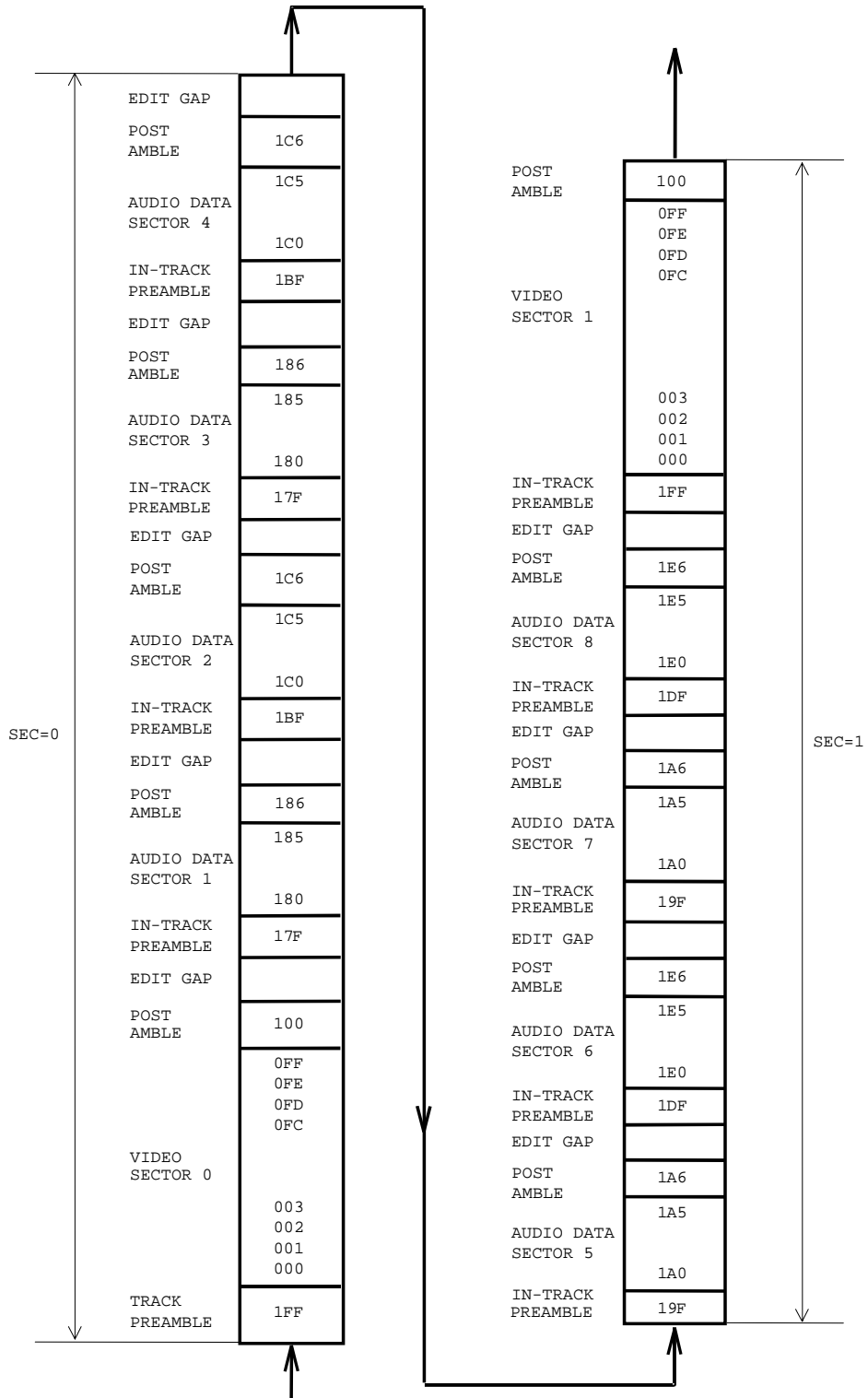

NOTE - Sync block number shows in hexadecimal notation.

Figure 15 – Sync block number (525/60 system)

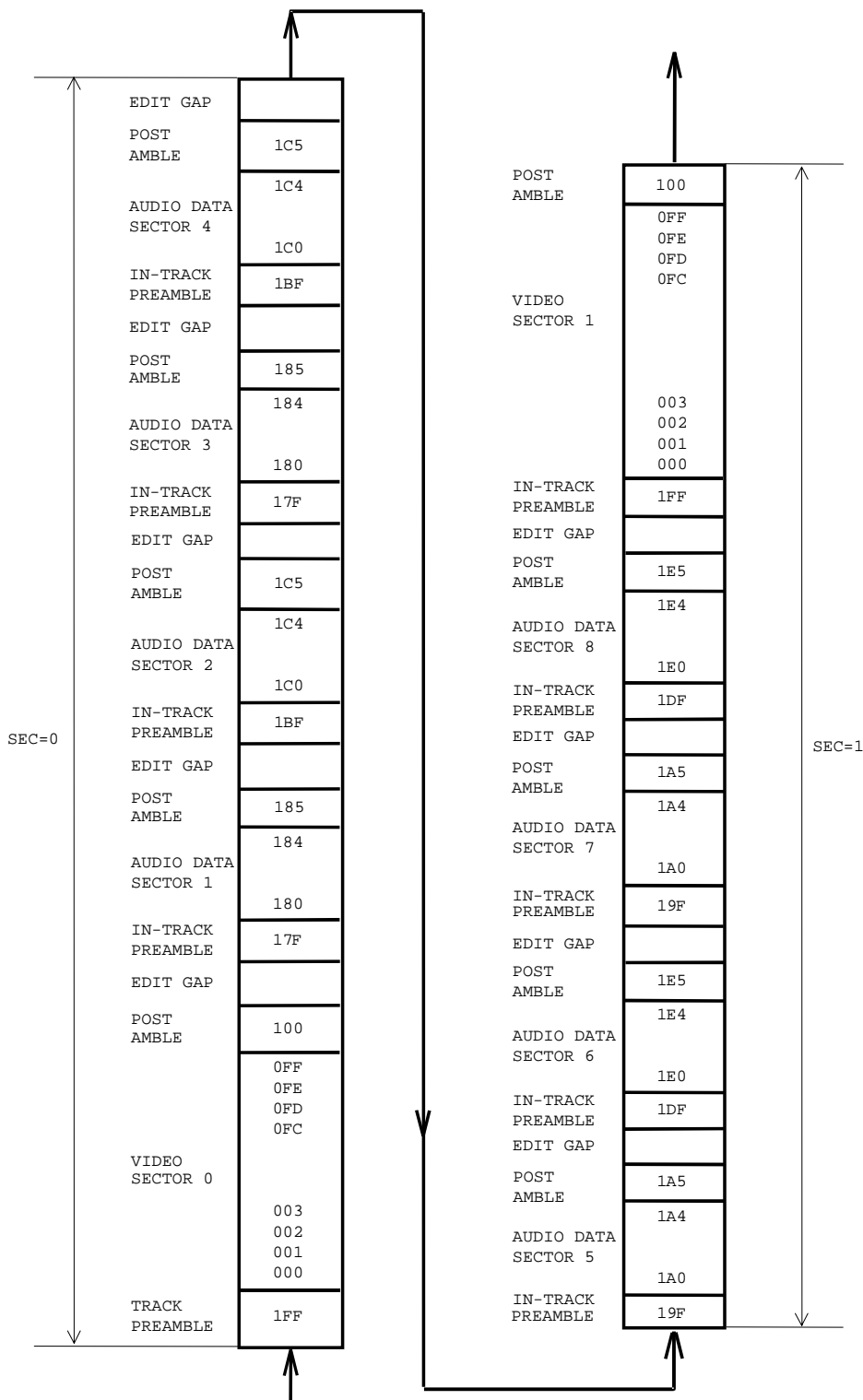

NOTE - Sync block number shows in hexadecimal notation.

Figure 16 – Sync block number (625/50 system)

f) Randomization: The identification pattern is randomized before being channel coded. The randomizing is equivalent to performing the exclusive-OR operation between the serial data stream and the serial stream generated by the polynomial function

$$x^8 + x^4 + x^3 + x^2 + 1 \text{ (in GF(2))}$$

The first term is the most significant and the first to enter the division computation. The polynomial generator noted above is preset to 15_h (525/60) system or 0C_h (625/50 system) at the first byte of the identification pattern and continues to cycle until the end of the sync block.

6.3.4 Data field

This block is used for all video and audio data and the associated error correction data.

a) Length: 1 inner code block. For the 525/60 system, the inner code block contains 95 bytes consisting of two identification pattern bytes, 85 data bytes (outer ECC check bytes are considered data), plus 8 inner ECC check bytes. For the 625/50 system, the inner code block contains 86 bytes consisting of two identification pattern bytes, 76 data bytes (outer ECC check bytes are considered data), plus 8 inner ECC check bytes.

b) Arrangement: See figures 9 and 10.

c) Interleaving: None.

d) Protection: Inner ECC code.

Type: Reed-Solomon.

Galois Field: GF(256).

Field generator polynomial: $x^8 + x^4 + x^3 + x^2 + 1$,
where x^i are place keeping variables in GF(2), the binary field.

Order of use : Left-most term is most significant, "oldest" in time computationally, and first written to tape.

Code generator polynomial in GF(256) is:

$$G(x) = (x+1)(x+a)(x+a^2)(x+a^3)(x+a^4)(x+a^5)(x+a^6)(x+a^7),$$

where a is given by 02_h in GF(256).

Check characters : $K_7, K_6, K_5, K_4, K_3, K_2, K_1, K_0$ in $K_7x^7 + K_6x^6 + K_5x^5 + K_4x^4 + K_3x^3 + K_2x^2 + K_1x + K_0$ obtained as the remainder after dividing $x^8D(x)$ by $G(x)$, where

$$D(x) = ID_0x^{86} + ID_1x^{85} + B_{84}x^{84} + \dots + B_2x^2 + B_1x + B_0 \text{ (525/60 system);}$$

$$D(x) = ID_0x^{77} + ID_1x^{76} + B_{75}x^{75} + \dots + B_2x^2 + B_1x + B_0 \text{ (625/50 system).}$$

Polynomial of full code :

$$ID_0x^{94} + ID_1x^{93} + B_{84}x^{92} + B_{83}x^{91} + \dots + B_1x^9 + B_0x^8 + K_7x^7 + K_6x^6 + \dots + K_2x^2 + K_1x + K_0$$

(525/60 system);

$$ID_0x^{85} + ID_1x^{84} + B_{75}x^{83} + B_{72}x^{82} + \dots + B_1x^9 + B_0x^8 + K_7x^7 + K_6x^6 + \dots + K_2x^2 + K_1x + K_0$$

(625/50 system).

e) Randomization: All data and error correction check characters are randomized before being channel coded. The randomization is equivalent to randomization as defined in 6.3.3 e).

6.3.5 Sector preamble

All sectors are preceded by a preamble consisting of a clock run-up sequence, sync pattern (2 bytes), identification pattern (2 bytes), and fill pattern (4 bytes). The clock run-up sequence varies in length depending on the sector. The remaining elements of the preamble have the same format for all sectors. When a sector is edited, the appropriate preamble, including the run-up sequence, shall be recorded.

6.3.5.1 Track preamble (T)

The track preamble precedes the first sector of every track. The total length of track preamble is 58 bytes long and contains 50 bytes of run-up pattern "2C_h" which is followed by two bytes of sync pattern, two bytes of identification pattern, and four bytes of fill pattern "00_h".

LSB	0	0	1	1	0	1	0	0	MSB
-----	---	---	---	---	---	---	---	---	-----

a) Arrangement: See figure 17 (a).

b) Total length: 58 bytes.

c) Run-up pattern: 2C_h.

d) Sync pattern: See 6.3.2.

e) Identification pattern: See 6.3.3.

f) Fill pattern: 00_h.

g) Protection: None.

h) Randomization: Only the identification pattern and fill pattern are randomized before being channel coded. The randomization is equivalent to randomization as defined in 6.3.3 e).

6.3.5.2 In-track preamble (E)

An in-track preamble precedes every sector except the first sector of a track. The total length is 28 bytes long and contains 20 bytes of run-up pattern "2C_h" followed by two bytes of sync pattern, two bytes of identification pattern, and four bytes of fill pattern "00_h".

a) Arrangement: See figure 17 (b).

b) Total length: 28 bytes.

c) Run-up pattern: 2C_h.

LSB	0	0	1	1	0	1	0	0	MSB
-----	---	---	---	---	---	---	---	---	-----

d) Sync pattern: See 6.3.2.

e) Identification pattern: See 6.3.3.

f) Fill pattern: 00_h.

g) Protection: None.

h) Randomization: Only the identification pattern and fill pattern are randomized before being channel coded. The randomization is equivalent to randomization as defined in 6.3.3 e).

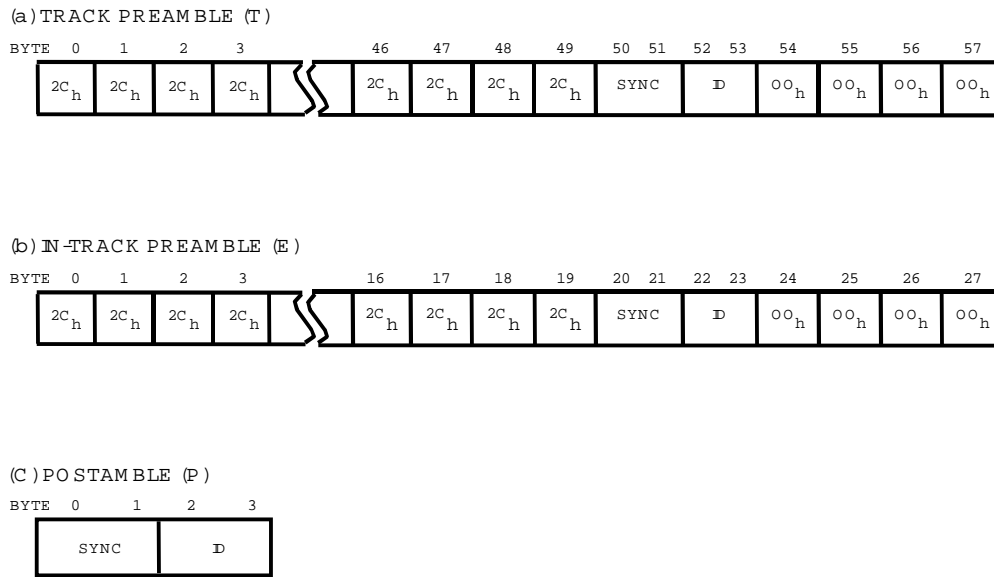

Figure 17 – Sector preamble and postamble

6.3.6 Sector postamble (P)

All sectors are followed by a postamble. The total length is four bytes and contains two bytes of sync pattern and two bytes of identification pattern.

a) Arrangement: See figure 17 (c).

b) Total length: 4 bytes.

c) Sync pattern: See 6.3.2.

d) Identification pattern: See 6.3.3.

e) Protection: None.

f) Randomization: Only the identification pattern is randomized before being channel coded. The randomization is equivalent to randomization as defined in 6.3.3 e).

6.4 Edit gaps

The spaces between individual sectors of a track, exclusive of preamble and postamble, are nominally 162 bytes long in the 525/60 system and 144 bytes long in the 625/50 system.

The edit gap is used to accommodate timing errors during editing. In an original recording, the edit gap shall contain a pattern $2C_h$. During an edit, the edit gap may be partially overwritten with $2C_h$ code provided that preamble and/or postamble of the adjacent unedited track sectors are not overwritten.

a) Protection: None.

b) Randomization: None.

6.5 Channel code

The channel code shall be an 8-14 modulation code which is defined by the following code rules.

NOTES

1 DSV is an abbreviation for digital sum variation and indicates the integral value which is counted from the beginning of the 8-14 modulated wave form, taking high level as 1 and low level as -1.

2 CDS is an abbreviation for code word digital sum and indicates the DSV of one symbol modulation code.

3 8-bit data entries in tables 4 and 5 are in hexadecimal notation.

Selecting the current 14-bit code, the following steps shall be taken:

1) Select a 14-bit code satisfying the following conditions of (A) and (B) from tables 4 and 5:

a) The number of consecutive identical bits at the joint portion with the preceding 14-bit code is two to seven.

b) The absolute value of the DSV at the end of the code (called end DSV hereafter) is equal to or less than two.

2) When two or more 14-bit codes are selected at step (1), choose a 14-bit code that gives the smallest absolute value of the end DSV.

3) When two or more 14-bit codes are still chosen in step (2), select a 14-bit code by calculating the DSV for each bit of the code (called bit DSV hereafter), determining the bit DSV the absolute value of which is minimum for each code, and choosing the code with the bit DSV whose minimum absolute value is smallest.

4) When two or more 14-bit codes are further found in step (3), select a 14-bit code by finding the maximum absolute value of the bit DSV of each code, and choosing a code with the bit DSV whose maximum absolute value is equal to or less than six.

5) When two or more codes are still found in step (4), select a 14-bit code satisfying the condition that the number of consecutive identical bits at the joint portion with the preceding 14-bit code is equal to or less than six.

6) When any codes selected at step (4) do not satisfy step (5), or two or more modulation codes satisfy step (5), select a 14-bit code satisfying the condition that the number of consecutive identical bits in that code is equal to or less than six.

7) When any codes selected at step (4) do not satisfy step (5) and step (6), or when any codes selected at step (5) do not satisfy step (6), or when two or more codes are further found at step (6), the following two steps shall be taken:

a) When the end DSV of the code is -2, select a code of higher priority (corresponding to a smaller number in table 6) according to table 6. Likewise, when the end DSV of the code is

+2, select a code of higher priority (corresponding to a smaller number in table 7) according to table 7.

b) When two or more codes belonging to the equal highest priority are found in step (a), select all of them temporarily. When the end DSV is zero, select a code satisfying the last six bits except when 111111 or 000000 are in the code.

8) When any codes selected at step (4) do not satisfy steps (5), (6), and (7), or when any codes selected at step (5) do not satisfy step (6) and step (7), or when any codes selected at step (6) do not satisfy step (7), or when two or more codes are further found at step (7), select a code with the bit DSV whose maximum absolute value is smallest.

9) When two or more codes are still found at step (8), select a 14-bit code with the bit DSV whose minimum absolute value appears earliest in the bit string of the code.

10) When two or more codes are further found at step (9), select a 14-bit code whose bit will be reversed earliest after the joint portion with the preceding code.

Table 4 – 8-14 modulation (CDS≥0)

Class	8-bit data	Modulation codes beginning with "0"	CDS	Class	8-bit data	Modulation codes Beginning with "1"	CDS
1(A)	00	01111110000001	0	1(B)	00	10000001111110	0
	01	01111100110000	0		01	10000011001111	0
	02	01111100011000	0		02	10000011100111	0
	03	01111100001100	0		03	10000011110011	0
	04	01111100000110	0		04	10000011111001	0
	05	01111100000011	0		05	10000011111100	0
	06	01111001110000	0		06	10000110001111	0
	07	01111001100001	0		07	10000110011110	0
	08	01111000111000	0		08	10000111000111	0
	09	01111000110001	0		09	10000111001110	0
	0A	01111000011100	0		0A	10000111100011	0
	0B	01111000011001	0		0B	10000111100110	0
	0C	01111000001110	0		0C	10000111110001	0
	0D	01111000000111	0		0D	10000111111000	0
	0E	01110011110000	0		0E	10001100001111	0
	0F	01110011100001	0		0F	10001100011110	0
	10	01110011001100	0		10	10001100110011	0
	11	01110011000110	0		11	10001100111001	0
	12	01110011000011	0		12	10001100111100	0
	13	01110001111000	0		13	10001110000111	0
	14	01110001110001	0		14	10001110001110	0
	15	01110001100110	0		15	10001110011001	0
	16	01110001100011	0		16	10001110011100	0
	17	01110000111100	0		17	10001111000011	0
	18	01110000111001	0		18	10001111000110	0
	19	01110000110011	0		19	10001111001100	0
	1A	01110000011110	0		1A	10001111100001	0
	1B	01110000001111	0		1B	10001111110000	0
	1C	01100111110000	0		1C	10011000001111	0
	1D	01100111100001	0		1D	10011000011110	0
	1E	01100111001100	0		1E	10011000110011	0
	1F	01100111000110	0		1F	10011000111001	0
	20	01100111000011	0		20	10011000111100	0
	21	01100110011100	0		21	10011001100011	0
	22	01100110011001	0		22	10011001100110	0
	23	01100110001110	0		23	10011001110001	0
	24	01100110000111	0		24	10011001111000	0
	25	01100011111000	0		25	10011100000111	0
26	01100011110001	0	26	10011100001110	0		
27	01100011100110	0	27	10011100011001	0		
28	01100011100011	0	28	10011100011100	0		
29	01100011001110	0	29	10011100110001	0		
2A	01100011000111	0	2A	10011100111000	0		
2B	01100001111100	0	2B	10011110000011	0		
2C	01100001111001	0	2C	10011110000110	0		
2D	01100001110011	0	2D	10011110001100	0		
2E	01100001100111	0	2E	10011110011000	0		
2F	01100000111110	0	2F	10011111000001	0		
30	01100000011111	0	30	10011111100000	0		
31	01111111001100	4	31	10000011111110	2		
32	01111111000110	4	32	10000110011111	2		
33	01111111000011	4	33	10000111001111	2		
34	01111110011100	4	34	10000111100111	2		
35	01111110011001	4	35	10000111110011	2		
36	01111110001110	4	36	10000111111001	2		
37	01111110000111	4	37	10000111111100	2		
38	01111100111100	4	38	10001100011111	2		

(continued)

Table 4 – 8-14 modulation (CDS≥0) (continued)

Class	8-bit data	Modulation codes beginning with "0"	CDS	Class	8-bit data	Modulation codes Beginning with "1"	CDS	
1(A)	39	01111100111001	4	1(B)	39	10001100111110	2	
	3A	01111100110011	4		3A	10001110001111	2	
	3B	01111100011110	4		3B	10001110011110	2	
	3C	01111100001111	4		3C	10001111000011	2	
	3D	01111001111100	4		3D	10001111001110	2	
	3E	01111001111001	4		3E	10001111100011	2	
	3F	01111001110011	4		3F	10001111100110	2	
	40	01111001100111	4		40	10001111110001	2	
	41	01111000111110	4		41	10001111111000	2	
	42	01111000011111	4		42	10011000011111	2	
	43	01110011111100	4		43	10011000111110	2	
	44	01110011111001	4		44	10011001100111	2	
	45	01110011110011	4		45	10011001110011	2	
	46	01110011100111	4		46	10011001111001	2	
	47	01110011001111	4		47	10011001111100	2	
	48	01110001111110	4		48	10011100001111	2	
	49	01110000111111	4		49	10011100011110	2	
	4A	01100111111100	4		4A	10011100110011	2	
	4B	01100111111001	4		4B	10011100111001	2	
	4C	01100111110011	4		4C	10011100111100	2	
	4D	01100111100111	4		4D	10011110000111	2	
	4E	01100111001111	4		4E	10011110001110	2	
	4F	01100110011111	4		4F	10011110011001	2	
	50	01100011111110	4		50	10011110011100	2	
	51	0111111000001	2		51	10011111000011	2	
	52	01111110011000	2		52	10011111000110	2	
	53	01111110001100	2		53	10011111001100	2	
	54	01111110000110	2		54	10011111100001	2	
	55	01111110000011	2		55	10011111110000	2	
	56	011111100111000	2		56	10001111001111	4	
	57	011111100110001	2		57	10001111100111	4	
	58	011111100011100	2		58	10001111110011	4	
	59	011111100011001	2		59	10011001111110	4	
	5A	011111100001110	2		5A	10011100111110	4	
	5B	011111100000111	2		5B	10011110001111	4	
	5C	011110011111000	2		5C	10011110011110	4	
	5D	01111001110001	2		5D	10011111000111	4	
	5E	01111001100110	2		5E	10011111001110	4	
	5F	01111001100011	2		5F	10011111100011	4	
	60	01111000111100	2		60	10011111100110	4	
	61	01111000111001	2		2(B)	61	11000111100111	4
	62	01111000110011	2			62	11000111110011	4
	63	01111000011110	2			63	11000000111111	2
	64	01111000001111	2			64	11000001111110	2
	65	011100111111000	2			65	11000011001111	2
	66	011100111110001	2			66	11000011100111	2
	67	011100111100110	2			67	11000011110011	2
	68	011100111100011	2			68	11000011111001	2
	69	011100110011110	2			69	11000011111100	2
	6A	011100110001111	2			6A	11000110001111	2
	6B	01110001111100	2		6B	11000110011110	2	
	6C	01110001111001	2		6C	11000111000111	2	
	6D	01110001110011	2		6D	11000111001110	2	
	6E	01110001100111	2		6E	11000111100011	2	
	6F	01110000111110	2		6F	11000111100110	2	
	70	01110000011111	2		70	11000111110001	2	

(continued)

Table 4 – 8-14 modulation (CDS≥0) (continued)

Class	8-bit data	Modulation codes beginning with "0"	CDS	Class	8-bit data	Modulation codes Beginning with "1"	CDS
1(A)	71	01100111111000	2	2(B)	71	11000111111000	2
	72	01100111110001	2		72	11001100001111	2
	73	01100111100110	2		73	11001100011110	2
	74	01100111100011	2		74	11001100110011	2
	75	01100111001110	2		75	11001100111001	2
	76	01100111000111	2		76	11001100111100	2
	77	01100110011110	2		77	11001110000111	2
	78	01100110001111	2		78	11001110001110	2
	79	01100011111100	2		79	11001110011001	2
	7A	01100011111001	2		7A	11001110011100	2
	7B	01100011110011	2		7B	11001111000011	2
	7C	01100011100111	2		7C	11001111000110	2
	7D	01100011001111	2		7D	11001111001100	2
	7E	01100001111110	2		7E	11001111100001	2
7F	01100000111111	2	7F	11001111110000	2		
2(A)	80	00111111100000	0	80	11000000111111	0	
	81	00111111000001	0	81	11000000111110	0	
	82	00111110011000	0	82	11000001100111	0	
	83	00111110001100	0	83	11000001110011	0	
	84	00111110000110	0	84	11000001111001	0	
	85	00111110000011	0	85	11000001111100	0	
	86	00111100111000	0	86	11000011000111	0	
	87	00111100110001	0	87	11000011001110	0	
	88	00111100011100	0	88	11000011100011	0	
	89	00111100011001	0	89	11000011100110	0	
	8A	00111100001110	0	8A	11000011110001	0	
	8B	00111100000111	0	8B	11000011111000	0	
	8C	00111001111000	0	8C	11000110000111	0	
	8D	00111001110001	0	8D	11000110001110	0	
	8E	00111001100110	0	8E	11000110011001	0	
	8F	00111001100011	0	8F	11000110011100	0	
	90	00111000111100	0	90	11000111000011	0	
	91	00111000111001	0	91	11000111000110	0	
	92	00111000110011	0	92	11000111001100	0	
	93	00111000011110	0	93	11000111100001	0	
	94	00111000001111	0	94	11000111110000	0	
	95	00110011111000	0	95	11001100000111	0	
	96	00110011110001	0	96	11001100001110	0	
	97	00110011100110	0	97	11001100011001	0	
	98	00110011100011	0	98	11001100011100	0	
	99	00110011001110	0	99	11001100110001	0	
	9A	00110011000111	0	9A	11001100111000	0	
	9B	00110001111100	0	9B	11001110000011	0	
	9C	00110001111001	0	9C	11001110000110	0	
	9D	00110001110011	0	9D	11001110001100	0	
9E	00110001100111	0	9E	11001110011000	0		
9F	00110000111110	0	9F	11001111000001	0		
A0	00110000011111	0	A0	11001111100000	0		
A1	00111111100001	2	A1	11001100111110	4		
A2	00111111001100	2	A2	11001110011110	4		
A3	00111111000110	2	A3	11001111000111	4		
A4	00111111000011	2	A4	11001111001110	4		
A5	00111110011100	2	A5	11001111100011	4		
A6	00111110011001	2	A6	11001111100110	4		

(continued)

Table 4 – 8-14 modulation (CDS≥0) (continued)

Class	8-bit data	Modulation codes beginning with "0"	CDS	Class	8-bit data	Modulation codes Beginning with "1"	CDS
2(A)	A7	00111110001110	2	3(B)	A7	11100001111110	4
	A8	00111110000111	2		A8	11100011100111	4
	A9	001111100111100	2		A9	11100011110011	4
	AA	001111100111001	2		AA	11100011111100	4
	AB	001111100110011	2		AB	11100110011110	4
	AC	001111100011110	2		AC	11100111000111	4
	AD	001111100001111	2		AD	11100111001110	4
	AE	00111001111100	2		AE	11100111100011	4
	AF	00111001111001	2		AF	11100111100110	4
	B0	00111001110011	2		B0	11100111111000	4
	B1	00111001100111	2		B1	11100000011111	2
	B2	00111000111110	2		B2	11100000111110	2
	B3	00111000011111	2		B3	11100001100111	2
	B4	00110011111100	2		B4	11100001110011	2
	B5	00110011111001	2		B5	11100001111001	2
	B6	00110011110011	2		B6	11100001111100	2
	B7	00110011100111	2		B7	11100011000111	2
	B8	00110011001111	2		B8	11100011001110	2
	B9	00110001111110	2		B9	11100011100011	2
	BA	00110000111111	2		BA	11100011100110	2
BB	00111111100110	4	BB	11100011110001	2		
BC	00111111100011	4	BC	11100011111000	2		
BD	00111111001110	4	BD	11100110000111	2		
BE	00111111000111	4	BE	11100110001110	2		
BF	00111110011110	4	BF	11100110011001	2		
C0	00111110001111	4	C0	11100110011100	2		
C1	00111110011110	4	C1	11100111000011	2		
C2	00111110001111	4	C2	11100111000110	2		
C3	00111001111110	4	C3	11100111001100	2		
C4	00111000111111	4	C4	11100111100001	2		
C5	00110011111110	4	C5	11100111110000	2		
3(A)	C6	00011111110000	0	C6	11100000001111	0	
	C7	000111111100001	0	C7	11100000011110	0	
	C8	00011111001100	0	C8	11100000110011	0	
	C9	00011111000110	0	C9	11100000111001	0	
	CA	00011111000011	0	CA	11100000111100	0	
	CB	00011110011100	0	CB	11100001100011	0	
	CC	00011110011001	0	CC	11100001100110	0	
	CD	00011110001110	0	CD	11100001110001	0	
	CE	00011110000111	0	CE	11100001111000	0	
	CF	00011100111100	0	CF	11100011000011	0	
	D0	00011100111001	0	D0	11100011000110	0	
	D1	00011100110011	0	D1	11100011001100	0	
	D2	00011100011110	0	D2	11100011100001	0	
	D3	00011100001111	0	D3	11100011110000	0	
	D4	00011001111100	0	D4	11100110000011	0	
	D5	00011001111001	0	D5	11100110000110	0	
D6	00011001110011	0	D6	11100110001100	0		
D7	00011001100111	0	D7	11100110011000	0		
D8	00011000111110	0	D8	11100111000001	0		
D9	00011000011111	0	D9	11100111100000	0		
DA	00011111110001	2	4(B)	DA	11110001111100	4	
DB	00011111100110	2	DB	11110011111000	4		
DC	00011111100011	2	DC	11110000001111	2		
DD	00011111001110	2	DD	11110000011110	2		

(continued)

Table 4 – 8-14 modulation (CDS≥0) (concluded)

Class	8-bit data	Modulation codes beginning with "0"	CDS	Class	8-bit data	Modulation codes Beginning with "1"	CDS
3(A)	DE	00011111000111	2	4(B)	DE	11110000110011	2
	DF	00011110011110	2		DF	11110000111001	2
	E0	00011110001111	2		E0	11110000111100	2
	E1	00011100111110	2		E1	11110001100011	2
	E2	00011100011111	2		E2	11110001100110	2
	E3	00011001111110	2		E3	11110001110001	2
	E4	00011000111111	2		E4	11110001111000	2
	E5	00011111110011	4		E5	11110011000011	2
	E6	00011111100111	4		E6	11110011000110	2
	E7	00011111001111	4		E7	11110011001100	2
4(A)	E8	00011110011111	4	E8	11110011100001	2	
	E9	00011100111111	4	E9	11110011110000	2	
	EA	00001111111000	0	EA	11110000000111	0	
	EB	00001111110001	0	EB	11110000001110	0	
	EC	00001111100110	0	EC	11110000011001	0	
	ED	00001111100011	0	ED	11110000011100	0	
	EE	00001110011110	0	EE	11110000110001	0	
	EF	00001110001111	0	EF	11110000111000	0	
	F0	00001110011110	0	F0	11110001100001	0	
	F1	00001110001111	0	F1	11110001110000	0	
5(A)	F2	00001100111110	0	F2	11110011000001	0	
	F3	00001100011111	0	F3	11110011100000	0	
	F4	00001111111001	2	5(B)	F4	11111000000111	2
	F5	00001111110011	2		F5	11111000001110	2
	F6	00001111100111	2		F6	11111000011001	2
	F7	00001111001111	2		F7	11111000011100	2
	F8	00001110011111	2		F8	11111000110001	2
	F9	00001100111111	2		F9	11111000111000	2
	FA	00000111111100	0		FA	11111001100001	2
	FB	00000111111001	0		FB	11111001110000	2
FC	00000111110011	0	FC		11111000001100	0	
FD	00000111100111	0	FD		11111000011000	0	
FE	00000111001111	0	FE	11111000110000	0		
FF	00000110011111	0	FF	11111001100000	0		

Table 5 – 8-14 modulation (CDS≤0)

Class	8-bit data	Modulation codes beginning with "0"	CDS	Class	8-bit data	Modulation codes Beginning with "1"	CDS
1(C)	00	01111110000001	0	1(D)	00	10000011111110	0
	01	01111100110000	0		01	1000011001111	0
	02	01111100011000	0		02	1000011100111	0
	03	01111100001100	0		03	1000011110011	0
	04	01111100000110	0		04	1000011111001	0
	05	01111100000011	0		05	1000011111100	0
	06	01111001110000	0		06	10000110001111	0
	07	01111001100001	0		07	10000110011110	0
	08	01111000111000	0		08	10000111000111	0
	09	01111000110001	0		09	10000111001110	0
	0A	01111000011100	0		0A	10000111100011	0
	0B	01111000011001	0		0B	10000111100110	0
	0C	01111000001110	0		0C	10000111110001	0
	0D	01111000000111	0		0D	10000111111000	0
	0E	01110011110000	0		0E	10001100001111	0
	0F	01110011100001	0		0F	10001100011110	0
	10	01110011001100	0		10	10001100110011	0
	11	01110011000110	0		11	10001100111001	0
	12	01110011000011	0		12	10001100111100	0
	13	01110001111000	0		13	10001110000111	0
	14	01110001110001	0		14	10001110001110	0
	15	01110001100110	0		15	10001110011001	0
	16	01110001100011	0		16	10001110011100	0
	17	01110000111100	0		17	10001111000011	0
	18	01110000111001	0		18	10001111000110	0
	19	01110000110011	0		19	10001111001100	0
	1A	01110000011110	0		1A	10001111100001	0
	1B	01110000001111	0		1B	10001111110000	0
	1C	01100111110000	0		1C	10011000001111	0
	1D	01100111100001	0		1D	10011000011110	0
	1E	01100111001100	0		1E	10011000110011	0
	1F	01100111000110	0		1F	10011000111001	0
	20	01100111000011	0		20	10011000111100	0
	21	01100110011100	0		21	10011001100011	0
	22	01100110011001	0		22	10011001100110	0
	23	01100110001110	0		23	10011001110001	0
	24	01100110000111	0		24	10011001111000	0
	25	01100011111000	0		25	10011100000111	0
26	01100011110001	0	26	10011100001110	0		
27	01100011100110	0	27	10011100011001	0		
28	01100011100011	0	28	10011100011100	0		
29	01100011001110	0	29	10011100110001	0		
2A	01100011000111	0	2A	10011100111000	0		
2B	01100001111100	0	2B	10011110000011	0		
2C	01100001111001	0	2C	10011110000110	0		
2D	01100001110011	0	2D	10011110001100	0		
2E	01100001100111	0	2E	10011110011000	0		
2F	01100000111110	0	2F	10011111000001	0		
30	01100000011111	0	30	10011111100000	0		
31	01111100000001	-2	31	1000000110011	-4		
32	01111001100000	-2	32	1000000111001	-4		
33	01111000110000	-2	33	1000000111100	-4		
34	01111000011000	-2	34	1000000110011	-4		
35	01111000001100	-2	35	10000001100110	-4		
36	01111000000110	-2	36	1000000110001	-4		
37	01111000000011	-2	37	10000001111000	-4		
38	01110011100000	-2	38	10000011000011	-4		

(continued)

Table 5 – 8-14 modulation (CDS≤0) (continued)

Class	8-bit data	Modulation codes beginning with "0"	CDS	Class	8-bit data	Modulation codes Beginning with "1"	CDS
1(C)	39	01110011000001	-2	1(D)	39	10000011000110	-4
	3A	01110001110000	-2		3A	10000011001100	-4
	3B	01110001100001	-2		3B	10000011100001	-4
	3C	01110000111000	-2		3C	10000011110000	-4
	3D	01110000110001	-2		3D	10000110000011	-4
	3E	01110000011100	-2		3E	10000110000110	-4
	3F	01110000011001	-2		3F	10000110001100	-4
	40	01110000001110	-2		40	10000110011000	-4
	41	01110000000111	-2		41	10000111000001	-4
	42	01100111100000	-2		42	10000111100000	-4
	43	01100111000001	-2		43	10001100000011	-4
	44	01100110011000	-2		44	10001100000110	-4
	45	01100110001100	-2		45	10001100001100	-4
	46	01100110000110	-2		46	10001100011000	-4
	47	01100110000011	-2		47	10001100110000	-4
	48	01100011110000	-2		48	10001110000001	-4
	49	01100011100001	-2		49	10001111000000	-4
	4A	01100011001100	-2		4A	10011000000011	-4
	4B	01100011000110	-2		4B	10011000000110	-4
	4C	01100011000011	-2		4C	10011000001100	-4
	4D	01100001111000	-2		4D	10011000011000	-4
	4E	01100001110001	-2		4E	10011000110000	-4
	4F	01100001100110	-2		4F	10011001100000	-4
	50	01100001100011	-2		50	10011100000001	-4
	51	01100000111100	-2		51	10000000111110	-2
	52	01100000111001	-2		52	10000001100111	-2
	53	01100000110011	-2		53	10000001110011	-2
	54	01100000011110	-2		54	10000001111001	-2
	55	01100000001111	-2		55	10000001111100	-2
	56	01110000110000	-4		56	10000011000111	-2
	57	01110000011000	-4		57	10000011001110	-2
	58	01110000001100	-4		58	10000011100011	-2
59	01100110000001	-4	59	10000011100110	-2		
5A	01100011000001	-4	5A	10000011110001	-2		
5B	01100001110000	-4	5B	10000011111000	-2		
5C	01100001100001	-4	5C	10000110000111	-2		
5D	01100000111000	-4	5D	10000110001110	-2		
5E	01100000110001	-4	5E	10000110011001	-2		
5F	01100000011100	-4	5F	10000110011100	-2		
60	01100000011001	-4	60	10000111000011	-2		
61	00111000011000	-4	61	10000111000110	-2		
2(C)	62	00111000001100	-4	62	10000111001100	-2	
	63	00111110000000	-2	63	10000111100001	-2	
	64	00111110000001	-2	64	10000111110000	-2	
	65	00111100110000	-2	65	10001100000111	-2	
	66	00111100011000	-2	66	10001100001110	-2	
	67	00111100001100	-2	67	10001100011001	-2	
	68	00111100000110	-2	68	10001100011100	-2	
	69	00111100000011	-2	69	10001100110001	-2	
	6A	00111001110000	-2	6A	10001100111000	-2	
	6B	00111001100001	-2	6B	10001110000011	-2	
	6C	00111000111000	-2	6C	10001110000110	-2	
	6D	00111000110001	-2	6D	10001110001100	-2	
	6E	00111000011100	-2	6E	10001110011000	-2	
	6F	00111000011001	-2	6F	10001111000001	-2	
	70	00111000001110	-2	70	10001111100000	-2	

(continued)

Table 5 – 8-14 modulation (CDS≤0) (continued)

Class	8-bit data	Modulation codes beginning with "0"	CDS	Class	8-bit data	Modulation codes beginning with "1"	CDS
2©	71	00111000000111	-2	1(D)	71	10011000000111	-2
	72	00110011110000	-2		72	10011000001110	-2
	73	00110011100001	-2		73	10011000011001	-2
	74	00110011001100	-2		74	10011000011100	-2
	75	00110011000110	-2		75	10011000110001	-2
	76	00110011000011	-2		76	10011000111000	-2
	77	00110001111000	-2		77	10011001100001	-2
	78	00110001110001	-2		78	10011001110000	-2
	79	00110001100110	-2		79	10011100000011	-2
	7A	00110001100011	-2		7A	10011100000110	-2
	7B	00110000111100	-2		7B	10011100001100	-2
	7C	00110000111001	-2		7C	10011100011000	-2
	7D	00110000110011	-2		7D	10011100110000	-2
	7E	00110000011110	-2		7E	10011110000001	-2
	7F	00110000001111	-2		7F	10011111000000	-2
	80	00111111100000	0		2(D)	80	11000000011111
	81	00111111000001	0	81		11000000111110	0
	82	00111110011000	0	82		11000001100111	0
	83	00111110001100	0	83		11000001110011	0
	84	00111110000110	0	84		11000001111001	0
	85	00111110000011	0	85		11000001111100	0
	86	001111100111000	0	86		11000011000111	0
	87	001111100110001	0	87		11000011001110	0
	88	001111100011100	0	88		11000011100011	0
	89	001111100011001	0	89		11000011100110	0
	8A	001111100001110	0	8A		11000011110001	0
	8B	001111100000111	0	8B		11000011111000	0
	8C	00111001111000	0	8C		11000110000111	0
	8D	00111001110001	0	8D		11000110001110	0
	8E	00111001100110	0	8E		11000110011001	0
	8F	00111001100011	0	8F		11000110011100	0
	90	00111000111100	0	90		11000111000011	0
91	00111000111001	0	91	11000111000110		0	
92	00111000110011	0	92	11000111001100		0	
93	00111000011110	0	93	11000111100001		0	
94	00111000001111	0	94	11000111110000		0	
95	00110011111000	0	95	11001100000111		0	
96	00110011110001	0	96	11001100001110		0	
97	00110011100110	0	97	11001100011001		0	
98	00110011100011	0	98	11001100011100		0	
99	00110011001110	0	99	11001100110001		0	
9A	00110011000111	0	9A	11001100111000		0	
9B	00110001111100	0	9B	11001110000011		0	
9C	00110001111001	0	9C	11001110000110		0	
9D	00110001110011	0	9D	11001110001100		0	
9E	00110001100111	0	9E	11001110011000		0	
9F	00110000111110	0	9F	11001111000001		0	
A0	00110000011111	0	A0	11001111100000	0		
A1	00110011000001	-4	A1	11000000011110	-2		
A2	00110001100001	-4	A2	11000000110011	-2		
A3	00110000111000	-4	A3	11000000111001	-2		
A4	00110000110001	-4	A4	11000000111100	-2		
A5	00110000011100	-4	A5	11000001100011	-2		
A6	00110000011001	-4	A6	11000001100110	-2		

(continued)

Table 5 – 8-14 modulation (CDS≤0) (continued)

Class	8-bit data	Modulation codes beginning with "0"	CDS	Class	8-bit data	Modulation codes beginning with "1"	CDS
3(C)	A7	00011110000001	-4	2(D)	A7	11000001110001	-2
	A8	000111000011000	-4		A8	11000001111000	-2
	A9	00011100001100	-4		A9	11000011000011	-2
	AA	00011100000011	-4		AA	11000011000110	-2
	AB	00011001100001	-4		AB	11000011001100	-2
	AC	00011000111000	-4		AC	11000011100001	-2
	AD	00011000110001	-4		AD	11000011110000	-2
	AE	00011000011100	-4		AE	11000110000011	-2
	AF	00011000011001	-4		AF	11000110000110	-2
	B0	00011000000111	-4		B0	11000110001100	-2
	B1	00011111100000	-2		B1	11000110011000	-2
	B2	00011111000001	-2		B2	11000111000001	-2
	B3	00011110011000	-2		B3	11000111100000	-2
	B4	00011110001100	-2		B4	11001100000011	-2
	B5	00011110000110	-2		B5	11001100000110	-2
	B6	00011110000011	-2		B6	11001100001100	-2
	B7	000111000111000	-2		B7	11001100011000	-2
	B8	00011100110001	-2		B8	11001100110000	-2
	B9	00011100011100	-2		B9	11001110000001	-2
	BA	00011100011001	-2		BA	11001111000000	-2
	BB	00011100001110	-2		BB	11000000011001	-4
	BC	00011100000111	-2		BC	11000000011100	-4
	BD	00011001111000	-2		BD	11000000110001	-4
	BE	00011001110001	-2		BE	11000000111000	-4
	BF	00011001100110	-2		BF	11000001100001	-4
C0	00011001100011	-2	C0	11000001110000	-4		
C1	00011000111100	-2	C1	11000011000001	-4		
C2	00011000111001	-2	C2	11000011100000	-4		
C3	00011000110011	-2	C3	11000110000001	-4		
C4	00011000011110	-2	C4	11000111000000	-4		
C5	00011000001111	-2	C5	11001100000001	-4		
C6	00011111110000	0	3(D)	C6	11100000001111	0	
C7	00011111100001	0		C7	11100000011110	0	
C8	00011111001100	0		C8	11100000110011	0	
C9	00011111000110	0		C9	11100000111001	0	
CA	00011111000011	0		CA	11100000111100	0	
CB	00011110011100	0		CB	11100001100011	0	
CC	00011110011001	0		CC	11100001100110	0	
CD	00011110001110	0		CD	11100001110001	0	
CE	00011110000111	0		CE	11100001111000	0	
CF	00011100111100	0		CF	11100011000011	0	
D0	0001110011001	0		D0	11100011000110	0	
D1	00011100110011	0		D1	11100011001100	0	
D2	00011100011110	0		D2	11100011100001	0	
D3	00011100001111	0	D3	11100011110000	0		
D4	00011001111100	0	D4	11100110000011	0		
D5	00011001111001	0	D5	11100110000110	0		
D6	00011001110011	0	D6	11100110001100	0		
D7	00011001100111	0	D7	11100110011000	0		
D8	00011000111110	0	D8	11100111000001	0		
D9	00011000011111	0	D9	11100111100000	0		
4(C)	DA	00001110000011	-4	DA	11100000001110	-2	
	DB	00001100000111	-4	DB	11100000011001	-2	
	DC	00001111110000	-2	DC	11100000011100	-2	
	DD	00001111100001	-2	DD	11100000110001	-2	

(continued)

Table 5 – 8-14 modulation (CDS≤0) (concluded)

Class	8-bit data	Modulation codes beginning with "0"	CDS	Class	8-bit data	Modulation codes beginning with "1"	CDS	
4(C)	DE	00001111001100	-2	3(D)	DE	11100000111000	-2	
	DF	00001111000110	-2		DF	11100001100001	-2	
	E0	00001111000011	-2		E0	11100001110000	-2	
	E1	00001110011100	-2		E1	11100011000001	-2	
	E2	00001110011001	-2		E2	11100011100000	-2	
	E3	00001110001110	-2		E3	11100110000001	-2	
	E4	00001110000111	-2		E4	11100111000000	-2	
	E5	00001100111100	-2		E5	11100000001100	-4	
	E6	00001100111001	-2		E6	11100000011000	-4	
	E7	00001100110011	-2		E7	11100000110000	-4	
	E8	00001100011110	-2		E8	11100001100000	-4	
	E9	00001100001111	-2		E9	11100011000000	-4	
	EA	00001111111000	0		EA	11110000000111	0	
	EB	00001111110001	0		EB	11110000001110	0	
	EC	00001111100110	0		EC	11110000011001	0	
	ED	00001111100011	0		ED	11110000011100	0	
5(C)	EE	00001111001110	0	4(D)	EE	11110000110001	0	
	EF	00001111000111	0		EF	11110000111000	0	
	F0	00001110011110	0		F0	11110001100001	0	
	F1	00001110001111	0		F1	11110001110000	0	
	F2	00001100111110	0		F2	11110011000001	0	
	F3	00001100011111	0		F3	11110011100000	0	
	F4	00000111111000	-2		F4	11110000000110	-2	
	F5	00000111110001	-2		F5	11110000001100	-2	
	F6	00000111100110	-2		F6	11110000011000	-2	
	F7	00000111100011	-2		F7	11110000110000	-2	
	F8	00000111001110	-2		F8	11110001100000	-2	
	F9	00000111000111	-2		F9	11110011000000	-2	
	FA	00000110011110	-2		5(D)	FA	11111000000011	0
	FB	00000110001111	-2			FB	11111000000110	0
	FC	00000111110011	0			FC	11111000001100	0
	FD	00000111100111	0			FD	11111000011000	0
FE	00000111001111	0	FE	11111000110000		0		
FF	00000110011111	0	FF	11111001100000		0		

Table 6 – Priority of modulation code selection (end DSV = -2)

Modulation codes	Priority
xxxxxxx001	4
xxxxxxx0011	1
xxxxxxx00111	2
xxxxxxx001111	3
xxxxxxx0011111	8
xxxxxxx110	10
xxxxxxx1100	5
xxxxxxx11000	6
xxxxxxx110000	7
xxxxxxx1100000	9
xxxxx11000000	11

NOTES
 1 "x" is a don't-care bit (default value is meaningless).
 2 This table shall be used in the case where DSV at the end of modulation code is -2

Table 7 – Priority of modulation code selection (end DSV = +2)

Modulation codes	Priority
xxxxxxx110	4
xxxxxxx1100	1
xxxxxxx11000	2
xxxxxxx110000	3
xxxxxxx1100000	8
xxxxxxx001	10
xxxxxxx0011	5
xxxxxxx00111	6
xxxxxxx001111	7
xxxxxxx0011111	9
xxxxx00111111	11

NOTES
 1 "x" is a don't-care bit (default value is meaningless).
 2 This table shall be used in the case where DSV at the end of modulation code is +2.

The recorded data rate (for the scanner configuration defined in 5.6) and shortest recorded wavelength are given in table 8, provided for reference only.

Table 8 – Data rate and wavelength

Parameter	525/60 system	625/50 system
Total average data rate	322.97 Mb/s	319.5 Mb/s
Instantaneous channel data rate	82.2 Mb/s	82.2 Mb/s
Shortest recorded wavelength	0.59 μm	0.66 μm

6.6 Magnetization

6.6.1 Polarity

Reproduction of the tape record shall be without regard to the polarity of the recorded flux on the helical tracks.

6.6.2 Recorded equalization

The record head current applied to a head should generate a constant magnetic flux level within a gap from the lowest recorded frequency (i.e., approximately one-third the Nyquist frequency) to the Nyquist frequency.

6.6.3 Record level

The level of the record head current applied to a head with a gap should be optimized for best reproduced signal-to-noise ratio at the highest constant recorded frequency (i.e. the Nyquist frequency of the channel). Other methods of setting the record level are permitted, providing they achieve the same results.

7 Video interface (informative)

If following video signal interfaces are implemented, then they shall conform to the following:

525/60 system:

Analog interface	ITU-R BT.470-6
Digital parallel interface	SMPTE 125M
Digital serial interface	SMPTE 259M; level C

625/50 system:

Analog interface	ITU-R BT.470-6
Digital parallel interface	ITU-R BT.656
Digital serial interface	IEC 61179

8 Audio data interface (informative)

If an audio interface for serial digital input is implemented, then it shall conform to AES3 and for embedded audio shall conform to SMPTE 272M.

8.1 Encoding parameters

The digital audio signal is encoded according to the following parameters:

8.1.1 Sampling

a) The sampling frequency is 48.000 kHz and shall be related to the video horizontal frequency as follows:

$$48 \text{ kHz} = F_H \times 1144 / 375 \text{ (525/60 system);}$$

$$48 \text{ kHz} = F_H \times 384 / 125 \text{ (625/50 system).}$$

b) The resolution of each sample is 20 bits minimum, 24 bits maximum.

c) The coding is twos complement linear PCM.

8.1.2 Reference level

The recommended recorded audio data levels should conform to SMPTE RP 155.

8.2 Digital signal interface

The principal mode of interface is analog. The audio signal may also be input and output digitally in a bit-serial form. The bit-serial interface, if present, shall conform to AES3 without error checking.

9 Video processing

9.1 Introduction

The purpose of the video processing operation is to transform the input component video digital data into a form suitable for tape recording.

By reassembling odd and even samples of the luminance data, two equal-size data blocks are produced. All four data blocks, odd luminance Y_o , even luminance Y_e , color difference C_R , and color difference C_B , are of equal data volume.

Additional data space, 24 samples in duration, is added to each horizontal line of data for all four data blocks.

Color-difference samples C_R , C_B , and even-luminance samples Y_e are handled together as one group. Odd luminance samples are handled independently.

The total video data are distributed into 12 video blocks (4 channels, each channel with 3 video blocks) for the 525/60 system and 16 video blocks (4 channels, each channel with 4 video blocks) for the 625/50 system.

The data are converted from 10-bit words to 8-bit words and randomized. Column shuffling, outer error correction code addition, and interleaving operations, are performed.

Sync, ID, and inner error correction code, are added to each sync block, the smallest data block.

Prior to recording, randomization and 8–14 conversion are performed.

9.2 Recorded data

9.2.1 Recorded samples and lines of the television frame

Video samples and reserved data are recorded in the following manner: In a 525/60 system, 255 consecutive lines and in a 625/50 system, 304 consecutive lines of each field are recorded on tape. Each line contains the following data:

- Y : 720 samples/line of luminance signal (Y) plus 48 samples of reserved data;
- C_R : 360 samples/line of color-difference signal (C_R) plus 24 samples/lines of reserved data;
- C_B : 360 samples/line of color-difference signal (C_B) plus 24 samples/lines of reserved data.

The first recorded sample of each field shall vary as shown below.

525/60 system

- In field 1, the first recorded sample is number 0 of line 9;
- In field 2, the first recorded sample is number 0 of line 271.

625/50 system

- In field 1, the first recorded sample is number 0 of line 7;
- In field 2, the first recorded sample is number 0 of line 320.

When the first recorded line in the vertical blanking period of each field is not used, all samples shall be set to 040_h for luminance samples and to 200_h for color-difference samples.

Figures 13 and 14 show track, segment, and field numbers on the tape.

9.2.2 Non-recorded data (informative)

a) Information content received on the input interface in the indicated lines is not recorded on tape. The appropriate blanking, sync, and burst data are recreated for the output interface during playback, so compliance with relevant output signal standards is maintained.

525/60 system

- Field 1, lines 1 through line 8;
- Field 2, lines 264 through line 270.

625/50 system

- Field 1, from line 624 of previous field through line 6 of field 1;
- Field 2, from line 311 through line 319 of field 2.

9.3 Luminance separation and video reserve data

Luminance samples are separated into two groups consisting of odd and even samples (Y_o and Y_e). The two separated groups of luminance samples Y_o , Y_e together with color-difference samples C_R and C_B shall contain the picture content of 255 lines (525/60 system) or 304 lines (625/50 system) of the video signal. These four signals (Y_o , Y_e , C_R , C_B) are formatted into four groups of 360 samples each for each line of video data. These 360 samples on each line (see figures 18 and 19) are followed by 24 samples of video reserve data, which is internally to the recorder set to 000_h and reserved for future use.

9.4 Channel and video block distribution

The data of each sample shall be distributed by channel and segment as follows:

Let L be the television line number within the video field:

$$L = 0, 1, \dots, 254 \text{ (525/60 system)}$$
$$L = 0, 1, \dots, 303 \text{ (625/50 system)}$$

Let H be the horizontal sample location within line L:

$$H = 0, 1, \dots, 767$$

Samples of Y_e (luminance even samples) and their corresponding color-difference samples, C_R and C_B , are placed together within a given Vblk of a given channel. Samples of Y_o (luminance odd samples) are placed separately from Y_e sample groups in another Vblk in the same or different channel.

An index (I) follows each horizontal sample for channel distribution (Ch) and video block distribution (Vblk) in accordance with figures 20 and 21. The actual index for channel distribution and video block is indicated below.

For 525/60 system:

$$\begin{aligned} \text{Ch} &= \{\text{Chi} (H \bmod 6) + \text{int} (H/6) + L\} \bmod 4, \\ \text{Vblk} &= \text{Vblk}_i (H \bmod 6) \end{aligned}$$

For 625/50 system:

$$\begin{aligned} \text{Ch} &= \{\text{Chi} (H \bmod 8) + \text{int} (H/8) + L\} \bmod 4, \\ \text{Vblk} &= \text{Vblk}_i (H \bmod 8) \end{aligned}$$

where Chi and Vblk_i are constant values as follows:

For 525/60 system

H mod 6	0	1	2	3	4	5
Chi	0	2	1	1	3	0
Vblk _i	0	2	1	0	2	1

For 625/50 system

H mod 8	0	1	2	3	4	5	6	7
Chi	0	2	1	3	0	2	1	3
Vblk _i	0	0	1	1	2	2	3	3

Spls means the sample number of the horizontal direction of figures 20 and 21.

$$\text{Spls} = \text{int} (H/32) \quad (525/60 \text{ system})$$

$$\text{Spls} = \text{int} (H/24) \quad (625/50 \text{ system})$$

where

$$\text{Spls} = 0, 1, 2, \dots, 31 \quad (525/60 \text{ system})$$

$$\text{Spls} = 0, 1, 2, \dots, 23 \quad (625/50 \text{ system})$$

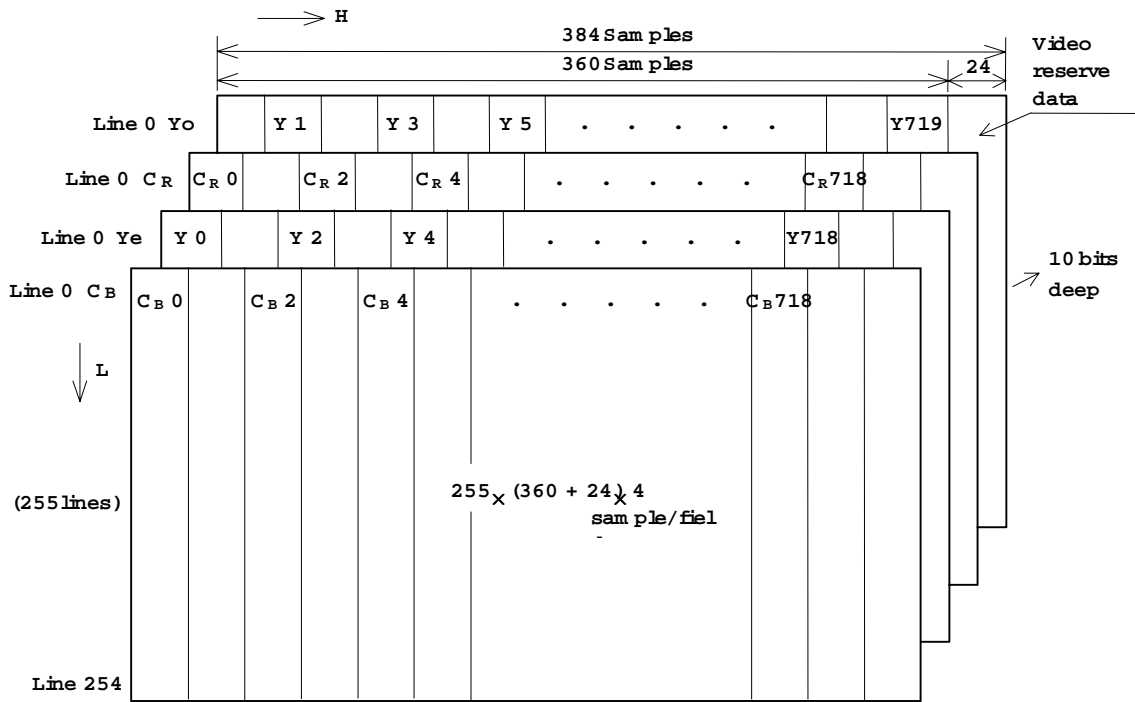

Figure 18 – Separated luminance and color-difference samples (525/60 system)

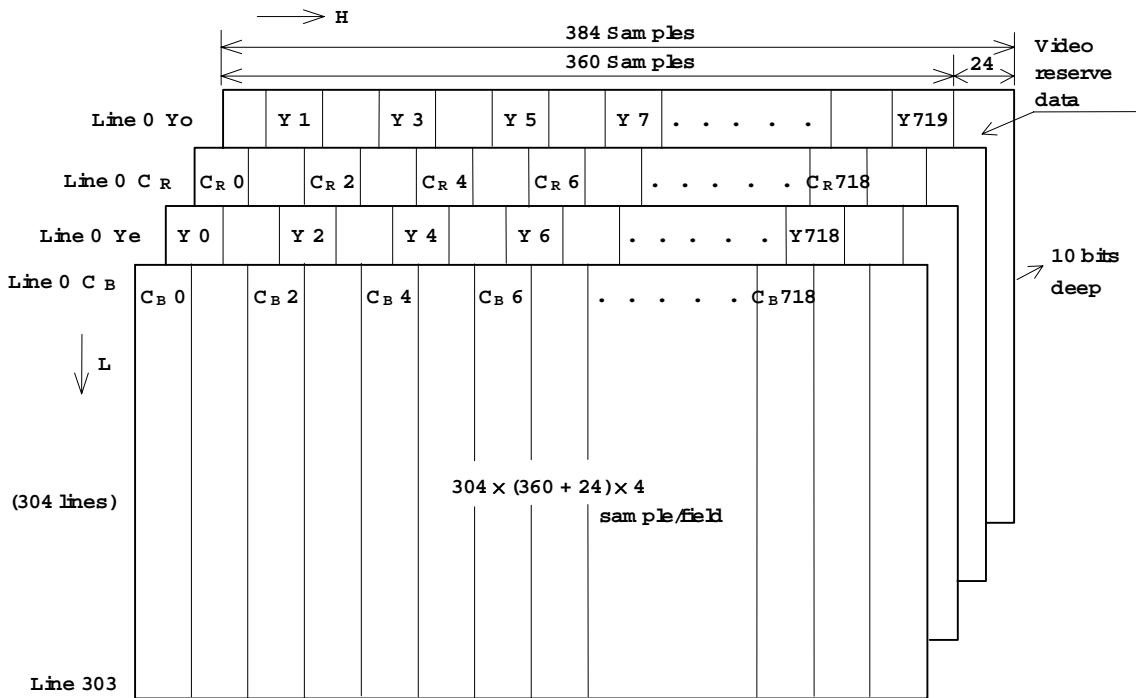

Figure 19 – Separated luminance and color-difference samples (625/50 system)

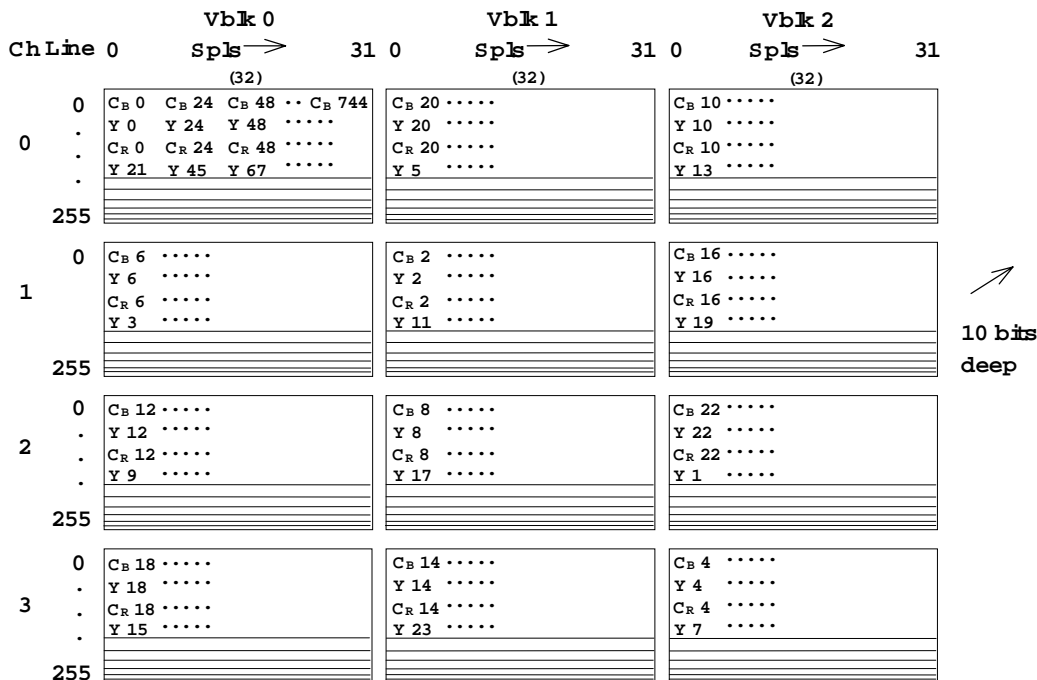

Figure 20 – Channel and video block distribution (525/60 system)

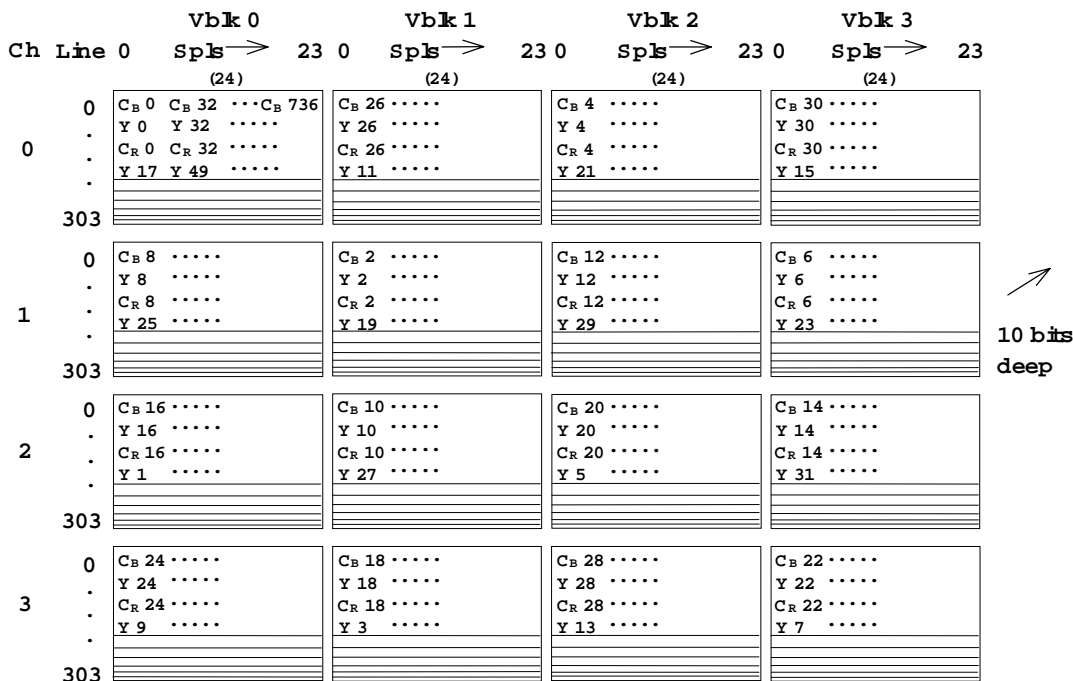
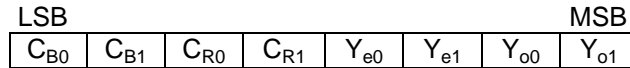

Figure 21 – Channel and video block distribution (625/50 system)

9.5 10/8-bit arrangement

Each data word consists of 10 bits. These 10-bit data words shall be separated into two groups where the first group contains eight MSBs of the original 10-bit data word and a second group contains the remaining two LSBs of the original 10-bit data word. The last two LSBs of C_B , C_R , Y_e , Y_o of the same sample are then combined into an 8-bit data word as shown below.



where subscripts 0 and 1 mean the LSB 2 bits.

Let S_{pll} be the sample number of the combined LSB 2-bit data:

$$S_{pll} = 0, 1, 2, \dots, 31 \text{ (525/60 system)}$$

$$S_{pll} = 0, 1, 2, \dots, 23 \text{ (625/50 system)}$$

Let $Comp$ be the component signal number as follows:

- Comp = 0: C_B signal
- Comp = 1: C_R signal
- Comp = 2: Y_e signal
- Comp = 3: Y_o signal

For 525/60 system:

$$S_{pll} = S_{pls} \quad (Comp = 0)$$

$$S_{pll} = S_{pls} \quad (Comp = 1)$$

$$S_{pll} = S_{pls} \quad (Comp = 2)$$

$$S_{pll} = (S_{pls} + 16) \bmod 32 \quad (Comp = 3)$$

For 625/50 system:

$$S_{pll} = S_{pls} \quad (Comp = 0)$$

$$S_{pll} = S_{pls} \quad (Comp = 1)$$

$$S_{pll} = S_{pls} \quad (Comp = 2)$$

$$S_{pll} = (S_{pls} + 12) \bmod 24 \quad (Comp = 3)$$

Combined LSB 2-bits group shall be relocated as described in figures 22 and 23.

Let O_c be the outer code number within a horizontal video line.

$$O_c = 0, 1, 2, 3.$$

Let S_{pla} be the sample number within a video block of each outer code block.

$$S_{pla} = 0, 1, \dots, 39 \text{ (525/60 system)}$$

$$S_{pla} = 0, 1, \dots, 29 \text{ (625/50 system)}$$

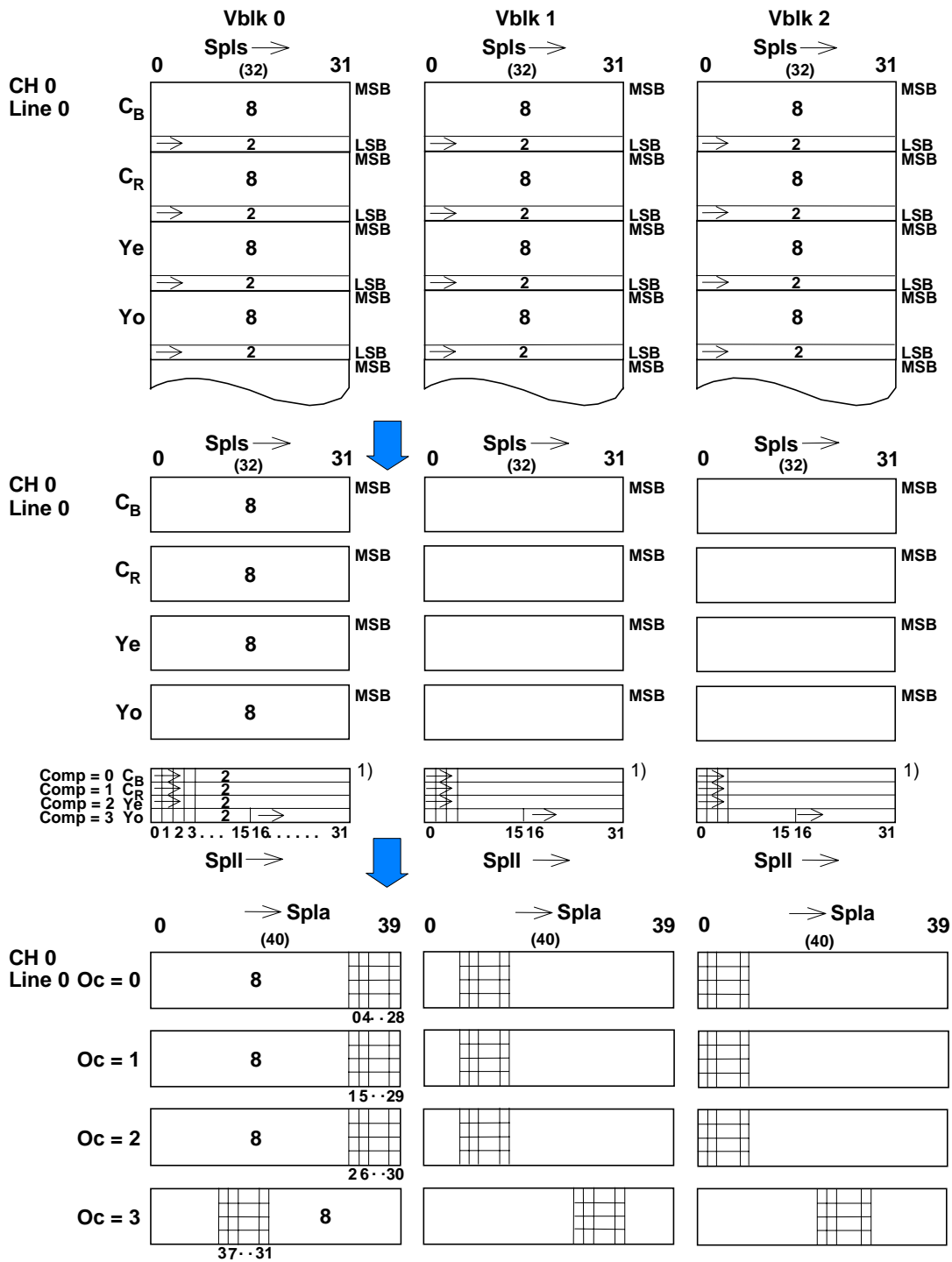
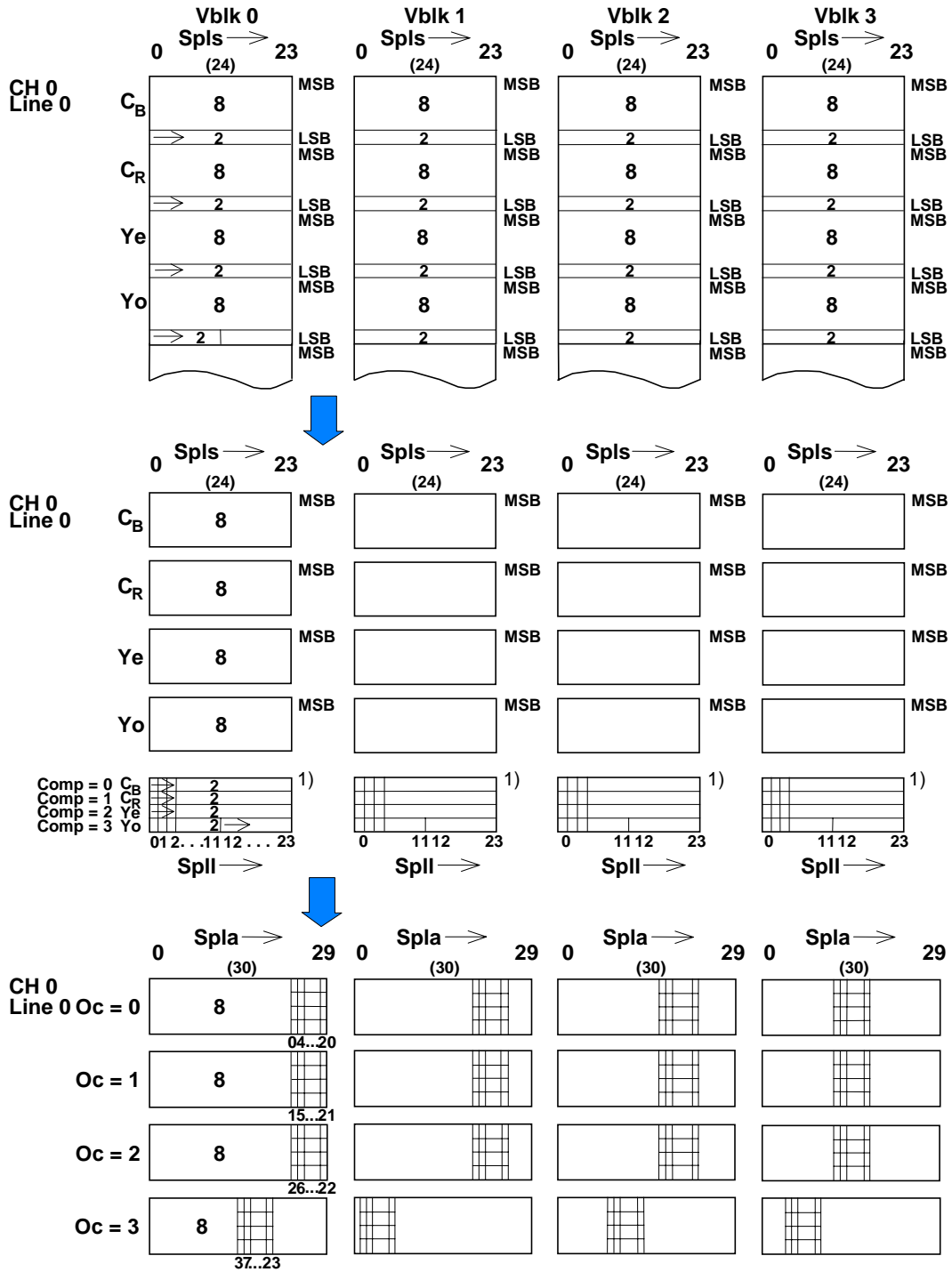

Figure 22 – 10 / 8 bit arrangement (525/60 system)



1) See 9.5.

Figure 23 – 10 / 8 bit arrangement (625/50 system)

The group of MSB 8-bits samples:

For 525/60 system

$$\begin{aligned} \text{Oc} &= \text{Comp} \\ \text{Spla} &= \{\text{Spls} + 20 * \text{Ch} + \text{A}(\text{Vblk}) + 39 * \text{L}\} \bmod 40 \quad (\text{Oc} = 0, 1, 2) \\ \text{Spla} &= \{\text{Spls} + 20 * \text{Ch} + \text{A}(\text{Vblk}) + 39 * \text{L} + 19\} \bmod 40 \quad (\text{Oc} = 3) \end{aligned}$$

$$\begin{aligned} \text{where } \text{A}(0) &= 0 \\ \text{A}(1) &= 14 \\ \text{A}(2) &= 8 \end{aligned}$$

For 625/50 system

$$\begin{aligned} \text{Oc} &= \text{Comp} \\ \text{Spla} &= \{\text{Spls} + 15 * \text{Ch} + \text{A}(\text{Vblk}) + 10 * \text{L}\} \bmod 30 \quad (\text{Oc} = 0, 1, 2) \\ \text{Spla} &= \{\text{Spls} + 15 * \text{Ch} + \text{A}(\text{Vblk}) + 10 * \text{L} + 21\} \bmod 30 \quad (\text{Oc} = 3) \end{aligned}$$

$$\begin{aligned} \text{where } \text{A}(0) &= 0 \\ \text{A}(1) &= 26 \\ \text{A}(2) &= 23 \\ \text{A}(3) &= 19 \end{aligned}$$

The group of LSB 2-bits samples:

For 525/60 system

$$\begin{aligned} \text{Oc} &= \text{Sp11} \bmod 4 \\ \text{Spla} &= \{32 + \text{int}(\text{Sp11}/4) + 20 * \text{Ch} + \text{A}(\text{Vblk}) + 39 * \text{L}\} \bmod 40 \quad (\text{Oc} = 0, 1, 2) \\ \text{Spla} &= \{32 + \text{int}(\text{Sp11}/4) + 20 * \text{Ch} + \text{A}(\text{Vblk}) + 39 * \text{L} + 19\} \bmod 40 \quad (\text{Oc} = 3) \end{aligned}$$

$$\begin{aligned} \text{where } \text{A}(0) &= 0 \\ \text{A}(1) &= 14 \\ \text{A}(2) &= 8 \end{aligned}$$

For 625/50 system

$$\begin{aligned} \text{Oc} &= \text{Sp11} \bmod 4 \\ \text{Spla} &= \{24 + \text{int}(\text{Sp11}/4) + 15 * \text{Ch} + \text{A}(\text{Vblk}) + 10 * \text{L}\} \bmod 30 \quad (\text{Oc} = 0, 1, 2) \\ \text{Spla} &= \{24 + \text{int}(\text{Sp11}/4) + 15 * \text{Ch} + \text{A}(\text{Vblk}) + 10 * \text{L} + 21\} \bmod 30 \quad (\text{Oc} = 3) \end{aligned}$$

$$\begin{aligned} \text{where } \text{A}(0) &= 0 \\ \text{A}(1) &= 26 \\ \text{A}(2) &= 23 \\ \text{A}(3) &= 19 \end{aligned}$$

Let Splo be the sample number within an outer code block.

$$\begin{aligned} \text{Splo} &= 40 * \text{Vblk} + \text{Spla} \quad (\text{525/60 system}) \\ \text{Splo} &= 30 * \text{Vblk} + \text{Spla} \quad (\text{625/50 system}) \\ \text{Splo} &= 0, 1, \dots, 119 \end{aligned}$$

9.6 Video randomization

Video randomization is performed to further reduce the direct current content of the video data stream. It is done after the 10/8 conversion, but prior to the integration of the outer code. Each video data word (byte) is replaced by a new word produced by an exclusive-OR operation between the original word and a random word. The random words are serial-to-parallel converted words (LSB-first order) from the random serial bit stream generated by the following polynomial function:

$$x^8 + x^4 + x^3 + x^2 + 1, \text{ (in GF(2))}$$

The random bit stream shall be pre-set to the following value for each outer code block:

$$M0 = 128 + (L \text{ mod } 128)$$

The next word of the random bit stream shall be exclusive-OR operated to the 1st word of the outer code block.

9.7 Outer error protection

Eight rows of each video field data array contain the error correction check data associated with each column of 8-bit bytes.

Type: Reed-Solomon.
 Galois field: GF(256).

Field generator polynomial: $x^8 + x^4 + x^3 + x^2 + 1$,
 where x^i are place-keeping variables in GF(2), the binary field.

Order of use: Left-most term is most significant, oldest in time computationally.

Code generator polynomial in GF(256):

$$G(x) = (x+1)(x+a)(x+a^2)(x+a^3)(x+a^4)(x+a^5)(x+a^6)(x+a^7),$$

where a is given by 02_h in GF(256).

Check characters: $K_7, K_6, K_5, K_4, K_3, K_2, K_1, K_0$ in $K_7x^7 + K_6x^6 + K_5x^5 + K_4x^4 + K_3x^3 + K_2x^2 + K_1x^1 + K_0$ obtained as the remainder after dividing $x^8D(x)$ by $G(x)$, where $D(x)$ is the polynomial given by $D(x) = B_{119}x^{119} + B_{118}x^{118} + \dots + B_2x^2 + B_1x + B_0$.

Equation of full code is given by: $B_{119}x^{127} + B_{118}x^{126} + B_{117}x^{125} \dots + B_1x^9 + B_0x^8 + K_7x^7 + K_6x^6 + K_5x^5 + K_4x^4 + K_3x^3 + K_2x^2 + K_1x + K_0$.

9.8 Field data array

The columns and rows for every field are shown below:

	Columns/field	Rows/field
525/60 system	1020	128
625/50 system	1216	128

The field data array is shown in figures 24 and 25.

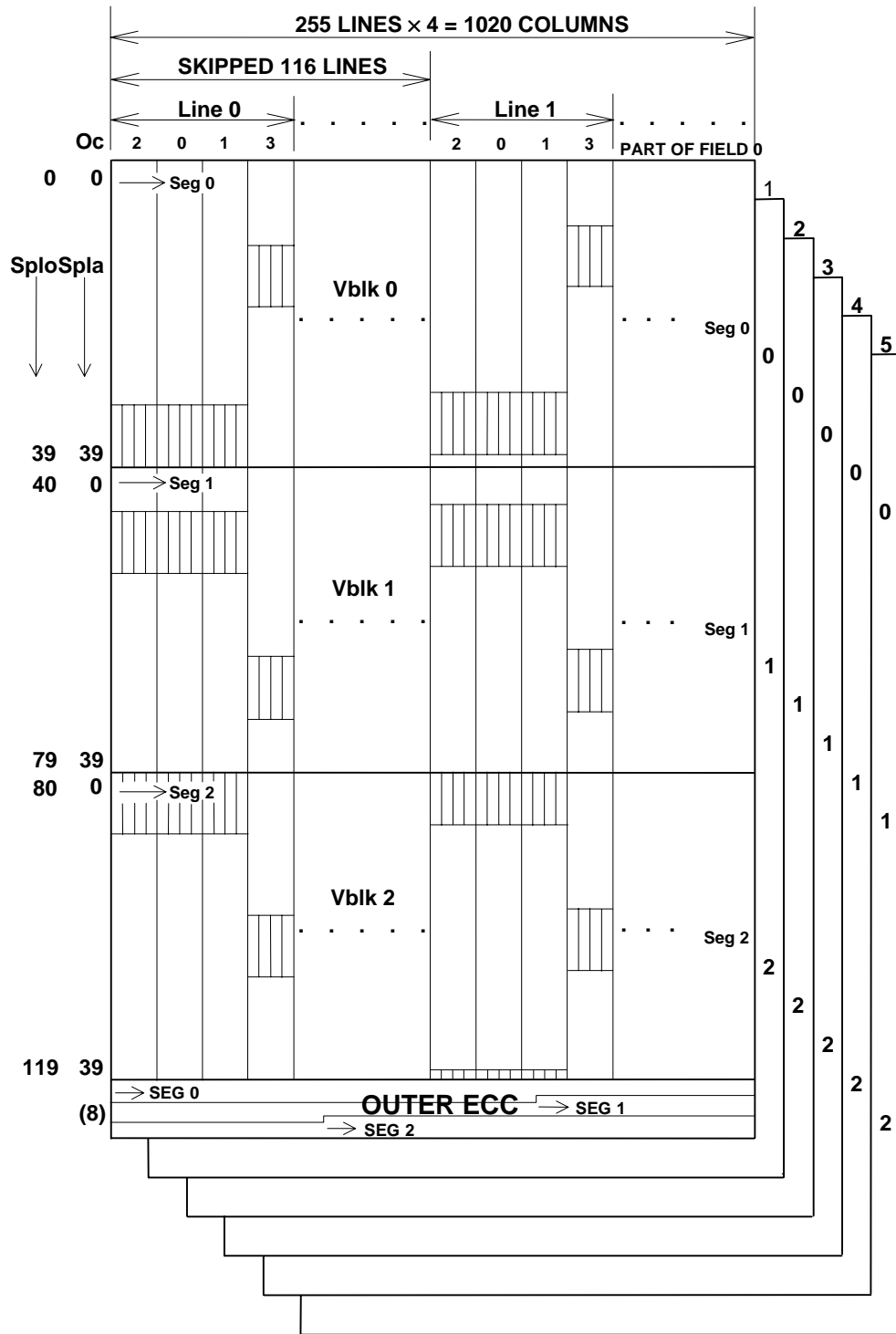

Figure 24 – Field data array (525/60 system)

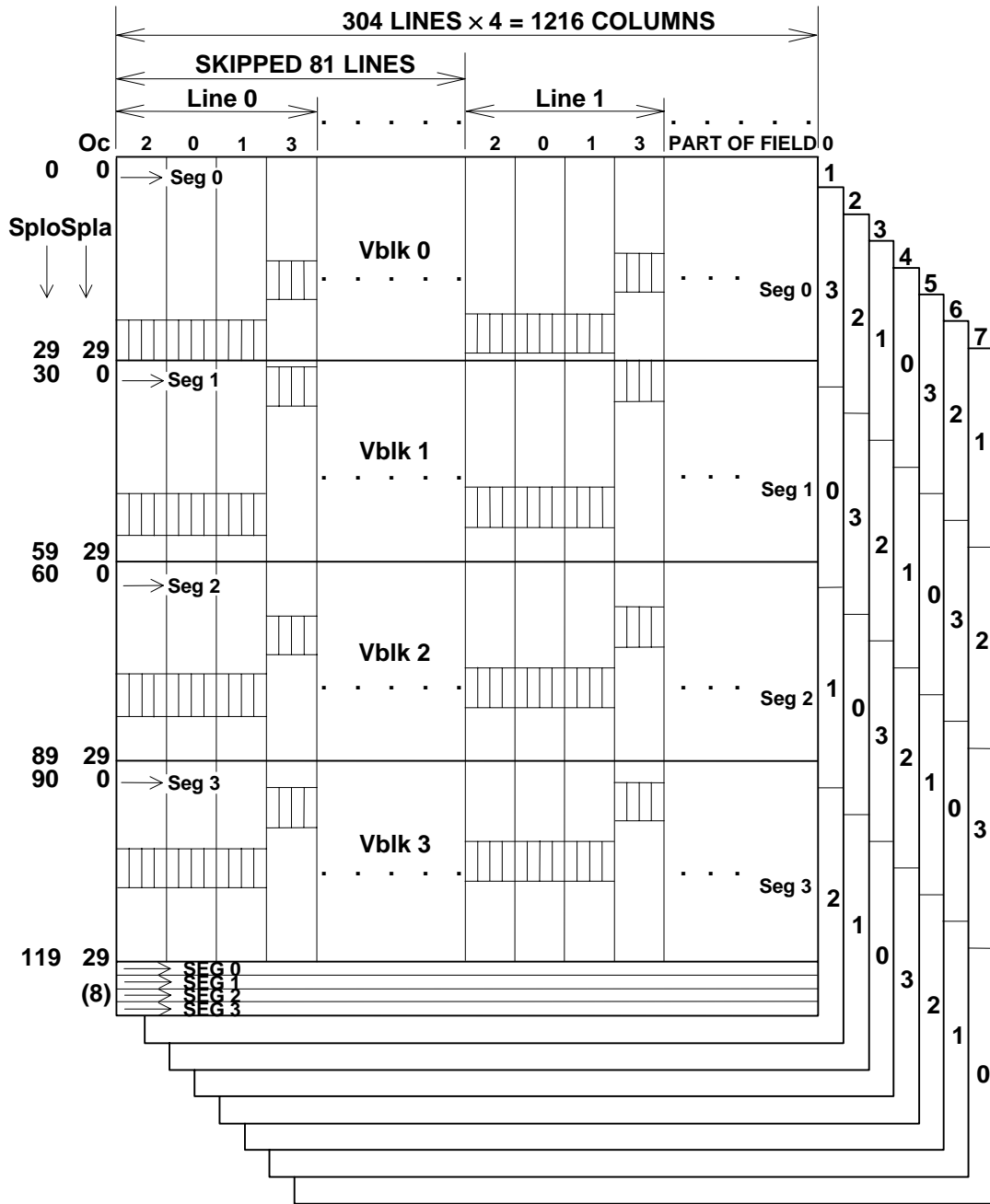

Figure 25 – Field data array (625/50 system)

Column shuffling is the relocation of the column of the field data array.

The sample number of the data in the outer code block Oc, Splo, is written into the field memory at the coordinates shown below:

$$\begin{aligned} \text{Row} &= \text{Splo} \\ \text{Col} &= 4 * (116 * L \bmod 255) + B (\text{Oc}) && (525/60 \text{ system}) \\ \text{Col} &= 4 * (81 * L \bmod 304) + B (\text{Oc}) && (625/50 \text{ system}) \end{aligned}$$

where B (0) = 1; B (1) = 2; B (2) = 0; B (3) = 3.

9.9 Order of transmission to inner coding

The field memory array data is written to tape first by ascending column order, then by ascending row order. Video data bytes and outer check bytes shall be divided into 3 segments (525/60 system) or 4 segments (625/50 system), respectively. The outer check bytes are written to tape first and followed by data bytes.

Let Seg be the segment number within a video field:

$$\begin{aligned} \text{Seg} &= 0, 1, 2 && (525/60 \text{ system}) \\ \text{Seg} &= 0, 1, 2, 3 && (625/50 \text{ system}) \end{aligned}$$

Let Fld be the field number within a color frame:

$$\begin{aligned} \text{Fld} &= 0, 1, 2, 3 && (525/60 \text{ system}) \\ \text{Fld} &= 0, 1, 2, 3 \dots 6, 7 && (625/50 \text{ system}) \end{aligned}$$

The start point address number Xin of the field memory array is as follows:

For the outer check bytes:

$$\begin{aligned} \text{Xin} &= 1440 + 32 * \text{Seg} && (525/60 \text{ system}) \\ \text{Xin} &= 1920 + 32 * \text{Seg} && (625/50 \text{ system}) \end{aligned}$$

For the outer data bytes:

$$\begin{aligned} \text{Xin} &= 480 * \text{Seg} \bmod 1440 && (525/60 \text{ system}) \\ \text{Xin} &= (480 * \text{Seg} + 480 * \text{Fld}) \bmod 1920 && (625/50 \text{ system}) \end{aligned}$$

The relationship between Xin and Row or Col of the field memory is:

$$\begin{aligned} \text{Xin} &= 12 * \text{Row} + \text{int} (\text{Col}/85) && (525/60 \text{ system}) \\ \text{Xin} &= 16 * \text{Row} + \text{int} (\text{Col}/76) && (625/50 \text{ system}) \end{aligned}$$

10 AES3 audio data processing

10.1 Introduction

Audio data in each of the eight channels is processed independently and identically into a product block for each channel of dimensions 85 x 4 columns by 8 rows (525/60 system) or 76 x 5 columns by 8 rows (625/50 system). The audio data samples of each channel are shuffled in a field before the addition of error correction data in the vertical (row) direction. Error correction in the horizontal (column) dimension is common with video data.

Auxiliary words are multiplexed with the audio data in the product block to provide housekeeping in the interface and in processing. Figures 26 (525/60 system) and 27 (625/50 system) show the audio data block field array.

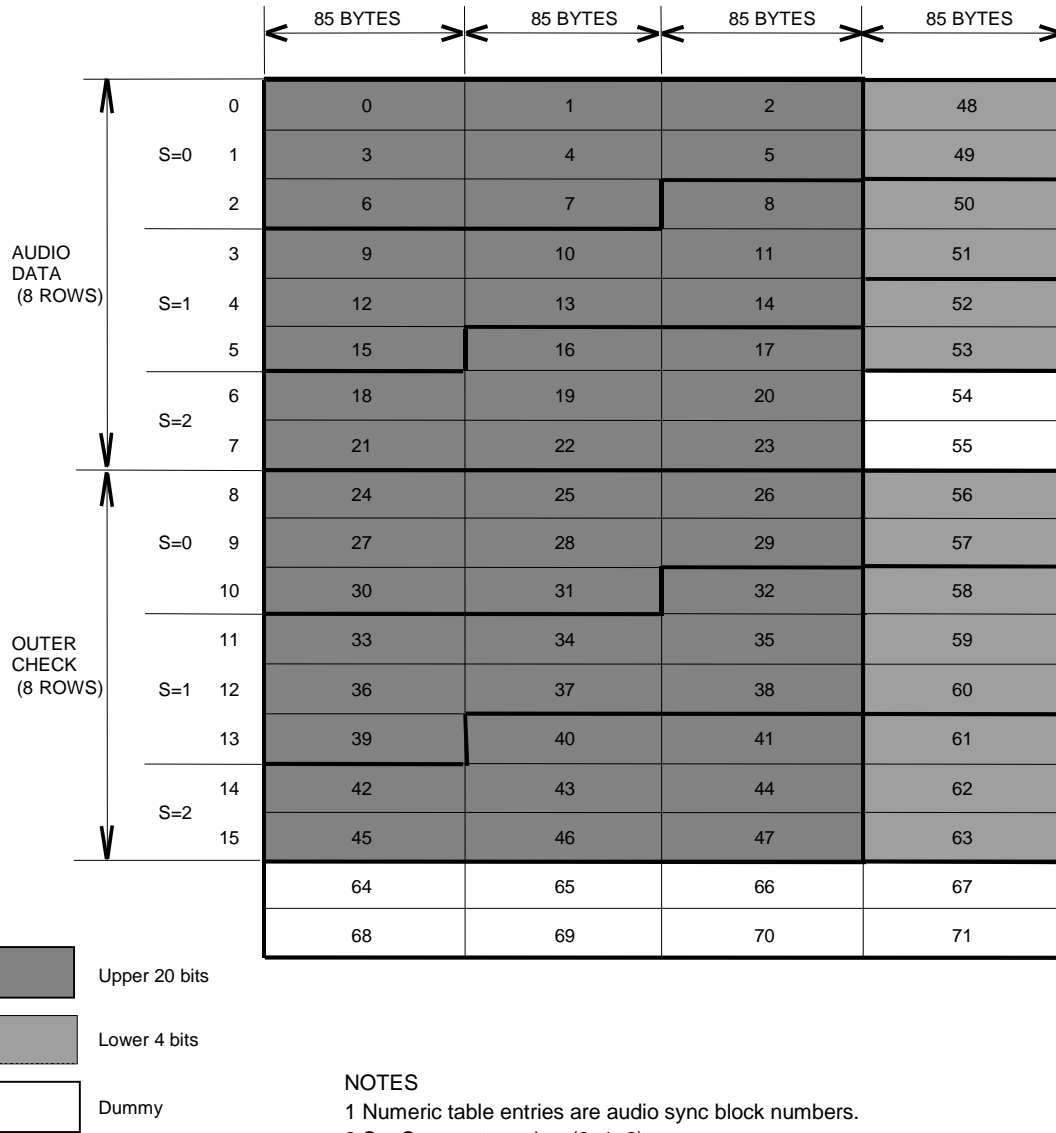
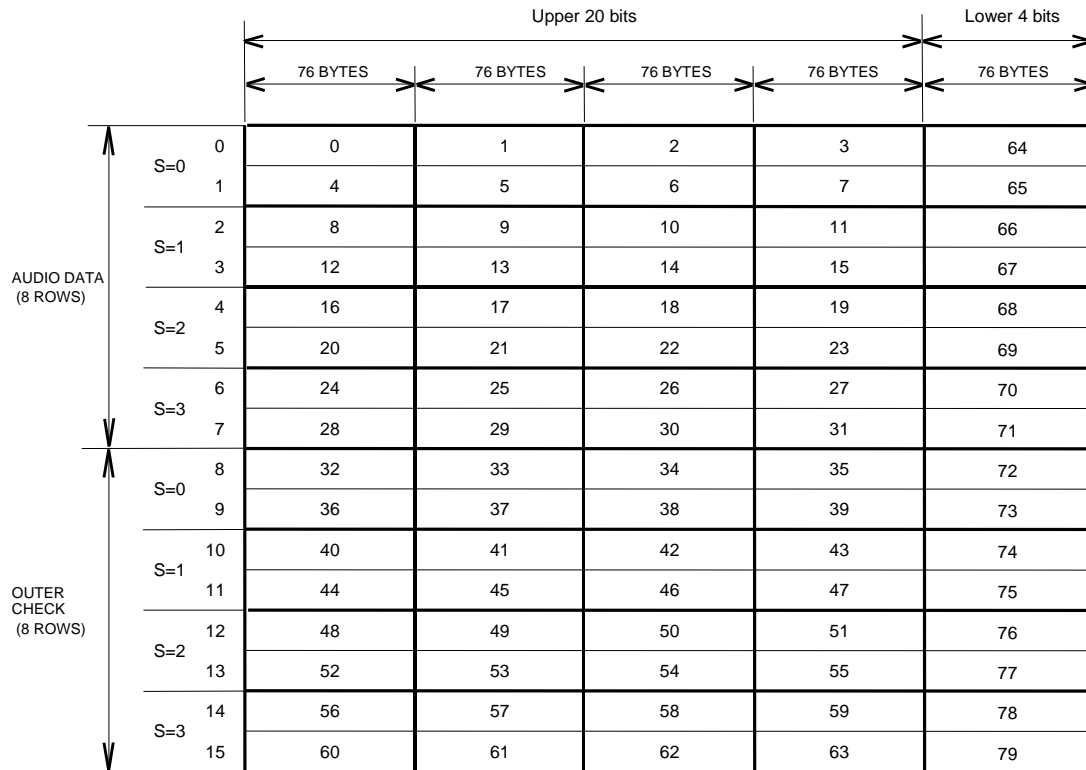

Figure 26 – Audio data block field array (525/60 system)



NOTES

- 1 Numeric table entries are audio sync block numbers.
- 2 S = Segment number (0, 1, 2, 3).

Figure 27 – Audio data block field array (625/50 system)

10.2 Source coding

Audio data records that meet the requirement of AES3-1992 are formed independently for each of the eight AES3 audio data channels, from audio data and ancillary data at the input interface. The data include AES3 audio data, channel status data (C), user data (U), and validity data (V). Parity bits are discarded. The remaining bit positions in the audio data words are reserved (R) for future use. Block sync marks for ancillary data are also processed. CCITT J.17 preemphasis is not recognized.

Source data is defined as follows:

a) AES3 audio data:

- Sampling frequency: 48 kHz \pm 3 parts in 10⁶, synchronous with video

b) Channel status data:

- Bit rate: 48 kbit/s (nominal)
- Word rate: 6 kByte/s
- Word length: 8 bits
- Block length: 192 bits, 24 words
- Coding: See AES3

NOTES

1 Bytes 0 and 1 of AES status data are selected only for special processing in the DVTR. The contents of bytes 0 and 1 are shown in tables 9 and 10, respectively.

2 Bytes 22 and 23 of AES status data contain protection and validity information for bytes 0-21 and may be used in some source decoders.

c) User data:

- Bit rate: One bit associated with each audio data word
- Coding: Undefined

d) Validity data:

- Bit rate: One bit associated with each audio data word
- Coding: 0 = sample valid
1 = sample defective

Table 9 – AES status data (Byte 0)

LSB				MSB			
0	1	2	3	4	5	6	7

- Bit 0: 0 = Consumer use
1 = Professional use
- Bit 1: 0 = Audio signal
1 = Data
- Bit 2: Pre-emphasis 0
- Bit 3: Pre-emphasis 1
- Bit 4: Pre-emphasis 2
- Bit 5: 0
- Bit 6: Sampling frequency 0
- Bit 7: Sampling frequency 1

NOTE – Bits 2, 3, and 4 of this byte are recorded in an auxiliary word.

Table 10 – AES status data (Byte 1)

LSB				MSB			
0	1	2	3	4	5	6	7

Bit 0: Channel mode bit 0
 Bit 1: Channel mode bit 1
 Bit 2: Channel mode bit 2
 Bit 3: Channel mode bit 3
 Bit 4: Reserved
 Bit 5: Reserved
 Bit 6: Reserved
 Bit 7: Reserved

Mode	0	1	2	3	Definition
0	0	0	0	0	Undefined-2 channel
1	0	0	0	1	2 Channel
2	0	0	1	0	Single channel
3	0	0	1	1	Primary/secondary 2 channel
4	0	1	0	0	Stereophonic
5	0	1	0	1	Reserved
			through		
F	1	1	1	1	Reserved

NOTE – Bits 0, 1, and 3 of this byte are recorded in an auxiliary word.

e) Parity bit:

- Bit rate: One bit associated with each audio data word
- Coding: Even parity of associated word including audio data, status, user, and validity data

10.3 Source processing

10.3.1 Introduction

AES3 audio data is processed in fields. Each field contains 801 or 800 AES3 audio data samples (525/60 system) or 960 AES3 audio data samples (625/50 system) for an AES3 audio data channel with associated status, user, and validity data. In addition, a number of control and user words are added to the data.

10.3.2 Relative audio signal-video timing

An audio data field begins with the audio data sample acquired zero samples (± 20 sample periods) before the first pre-equalizing pulse of the vertical interval of the analog input video signal. For digital input video signal a corresponding point (mark) to analog input is chosen as the beginning of the sampled audio field. That point depends on the status of F bit on the digital interface.

Audio signal timing relative to video signal timing at the output interface during playback shall be the same (temporal skew is equal to zero) as it was at the input interface

10.3.3 Audio data in fields

Audio data in fields are processed into an audio data block of 85 x 6 x 12 bytes (525/60 system) or 76 x 5 x 16 bytes (625/50 system), each corresponding to 12 audio data sectors (525/60 system) or 16 audio data sectors (625/50 system) on tape. The data portion of the block is 85 x 30 bytes (525/60 system) or 76 x 5 x 8

bytes (625/50 system) and the outer error check bytes portion of the block is also 85 x 32 bytes (525/60 system) or 76 x 5 x 8 bytes (625/50 system) and dummy data of the block is 85 x 10 (525/60 systems).

AES3 audio data words: 801 or 800 words (525/60 system) or 960 words (625/50 system) with associated C, U, V, R bits (24 bits total per word).

Auxiliary data words: 15 words (20 bits per word) + 170 words (8 bits per word) + 219 words (4 bits per word) (525/60 system); 32 words (8 bits per word) + 219 words (4 bits per word) (625/50 system).

10.3.4 Intra-field shuffling

The audio data for each channel in each field is shuffled. The intra-field shuffling process operates identically for all fields.

For upper 20 bits data.

Let Col be the column number within an audio data field:

$$\begin{aligned} \text{Col} &= 0, 1, \dots, 101. \text{ (Upper 20 bits of 525/60 system)} \\ \text{Col} &= 0, 1, \dots, 123. \text{ (Upper 20 bits of 625/50 system)} \end{aligned}$$

Let Row be the row number within an audio data field:

$$\text{Row} = 0, 1, \dots, 15$$

Row 8 to 15 contain the error correction data.

Let Oblk be the data block number:

$$\begin{aligned} \text{Oblk} &= 3 \times \text{Row} + \text{int}(\text{Col} / 34) \text{ (Upper 20 bits of 525/60 system)} \\ \text{Oblk} &= 4 \times \text{Row} + \text{int}(\text{Col} / 31) \text{ (Upper 20 bits of 625/50 system)} \end{aligned}$$

The data block array for upper 20 bits is shown in figures 28 (525/60 system) and 30 (625/50 system). Then sample number Smp within an audio data field is obtained according to the following formula:

$$\begin{aligned} \text{Smp} &= 24 \times (\text{Col} \bmod 34) + \text{int}(\text{Oblk} / 8) + 3 \times (\text{Oblk} \bmod 8) \text{ (Upper 20 bits of 525/60 system);} \\ \text{Smp} &= 32 \times (\text{Col} \bmod 31) + \text{int}(\text{Oblk} / 9) + 4 \times (\text{Oblk} \bmod 9) - 3 \times \text{int} \left[\frac{\{(\text{Oblk} \bmod 9) + \text{int}(\text{Oblk} / 9)\}}{8} \right] \\ &\quad \text{(Upper 20 bits of 625/50 system).} \end{aligned}$$

When Smp is larger than 800, Smp = 801, 802, . . . , 815 are replaced by AUX 0, AUX 1, . . . , AUX 14, respectively, for the 525/60 system;

When Smp is larger than 959, Smp = 960, 961, . . . , 991 are replaced by AUX 0, AUX 1, . . . , AUX 14, respectively, for the 625/50 system.

For lower 4 bits data.

Let Col be the column number within an audio data field:

$$\begin{aligned} \text{Col} &= 0, 1, \dots, 169. \text{ (Lower 4 bits of 525/60 system)} \\ \text{Col} &= 0, 1, \dots, 151. \text{ (Lower 4 bits of 625/50 system)} \end{aligned}$$

Let Row be the row number within an audio data field:

$$\text{Row} = 0, 1, \dots, 15$$

Rows 8 to 15 contain the error correction data.

The data block array for lower 4 bits is shown in figures 29 (525/60 system) and 31 (625/50 system). Then sample number Smp within a lower 4 bits audio data field is obtained according to the following formula:

For 525/60 system

$$\text{Smp} = 6 \times (\text{col} - 2 \text{int}(\text{Row} / 2)) + 3 \times (\text{Row} \bmod 2) + \text{int}(\text{Row}/2).$$

(Lower 4 bits of 525/60 system)

When Smp is larger than 800, Smp = 801, 802, . . . , 815 are replaced by AUX 0, AUX 1, . . . , AUX 14. When Smp is smaller than 0, Smp is replaced by AUX 219 + Smp, respectively.

For 625/50 system, col = 0 to 119

$$\text{Smp} = 8 \times (\text{col} - 15 \times \text{int}((\text{Row} + 7 \times (\text{Row} \bmod 2)) / 2)) + 4 \times (\text{Row} \bmod 2) + \text{int}(\text{Row}/2).$$

(Lower 4 bits of 625/50 system)

When Smp is smaller than 0, Smp is replaced by 960 + Smp.

For 625/50 system, col = 120 to 151

$$\text{Smp} = 8 \times (\text{col} - 4 \times \text{int}((\text{Row} + 7 \times (\text{Row} \bmod 2)) / 2)) + 4 \times (\text{Row} \bmod 2) + \text{int}(\text{Row}/2).$$

Smp is replaced by AUX Smp. When Smp is smaller than 0, Smp is replaced by AUX 256 + Smp, respectively.

Figures 28 and 29 (525/60 system) and figures 30 and 31 (625/50 system) show the layout of the shuffled samples in a field array. Outer ECC codes are situated at Row = 8 to 15.

10.3.5 Block shuffling

The block shuffling process operates after the intrafield shuffling identically for all fields.

Let Seg be the segment number:

$$\begin{aligned} \text{Seg} &= 0, 1, 2 \quad (525/60 \text{ system}) \\ \text{Seg} &= 0, 1, 2, 3 \quad (625/50 \text{ system}) \end{aligned}$$

Let T be the track number:

$$T = 0, 1, 2, 3$$

The data block is shown in figures 32 and 33 as to segment number and track number.

Figure 32 shows the data block arrangement of an audio data channel in three groups of sectors for the 525/60 system. Figure 33 shows the data block arrangement of an audio data channel in four groups of sectors for the 625/50 system.

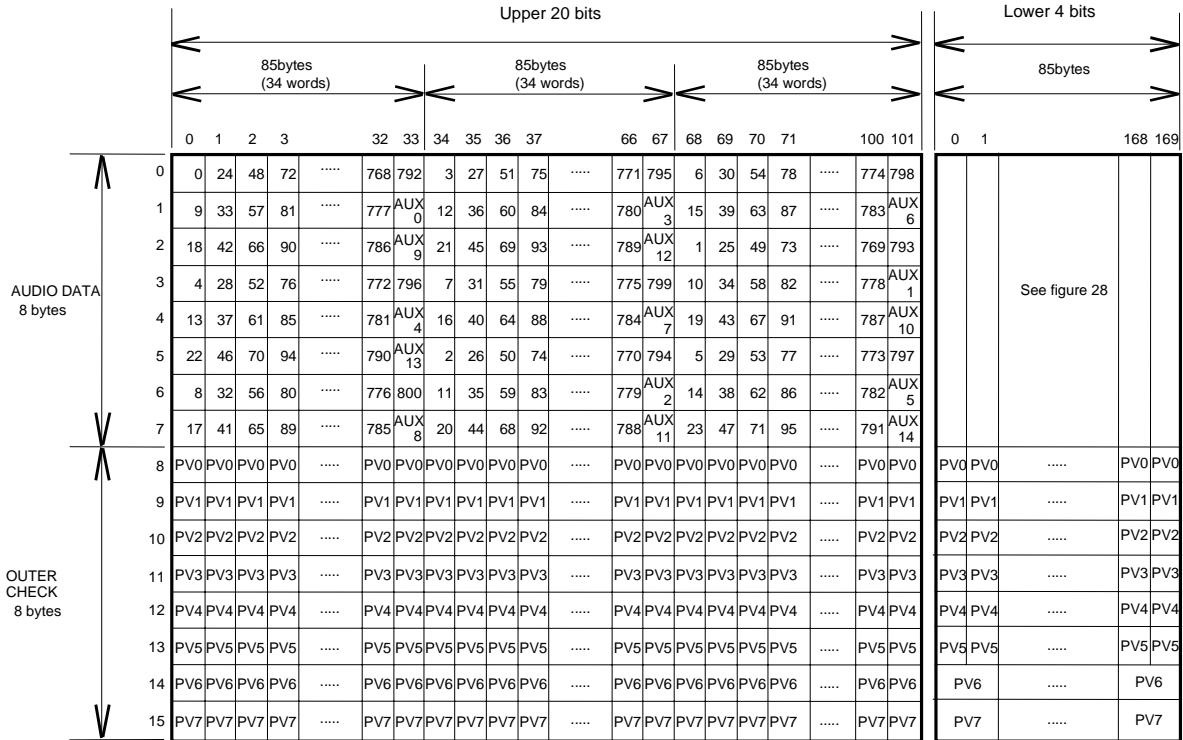

- NOTES**
- 1 Numeric table entries are audio sample numbers.
 - 2 PV0 to PV7 represent outer check corresponding to audio data of each column.

Figure 28 – Audio data block layout (525/60 system)

	0	1	2	3	4	5		132	133	134	135	136	137	138	139		168	169
0	0	6	12	18	24	30	792	798	AUX 3	AUX 9	AUX 15	AUX 21	AUX 27	AUX 33	AUX 207	AUX 213
1	3	9	15	21	27	33	795	AUX 0	AUX 6	AUX 12	AUX 18	AUX 24	AUX 30	AUX 36	AUX 210	AUX 216
2	AUX 208	AUX 214	1	7	13	19	781	787	793	799	AUX 4	AUX 10	AUX 16	AUX 22	AUX 196	AUX 202
3	AUX 211	AUX 217	4	10	16	22	784	790	796	AUX 1	AUX 7	AUX 13	AUX 19	AUX 25	AUX 199	AUX 205
4	AUX 197	AUX 203	AUX 209	AUX 215	2	8	770	776	782	788	794	800	AUX 5	AUX 11	AUX 185	AUX 191
5	AUX 200	AUX 206	AUX 212	AUX 218	5	11	773	779	785	791	797	AUX 2	AUX 8	AUX 14	AUX 188	AUX 194
6	AUX 219	AUX 220	AUX 221				AUX 285	AUX 286	AUX 287	AUX 288					AUX 303	
7	AUX 304	AUX 305	AUX 306				AUX 370	AUX 371	AUX 372	AUX 373					AUX 388	

Figure 29 – Audio data block layout – lower 4 bits (525/60 system)

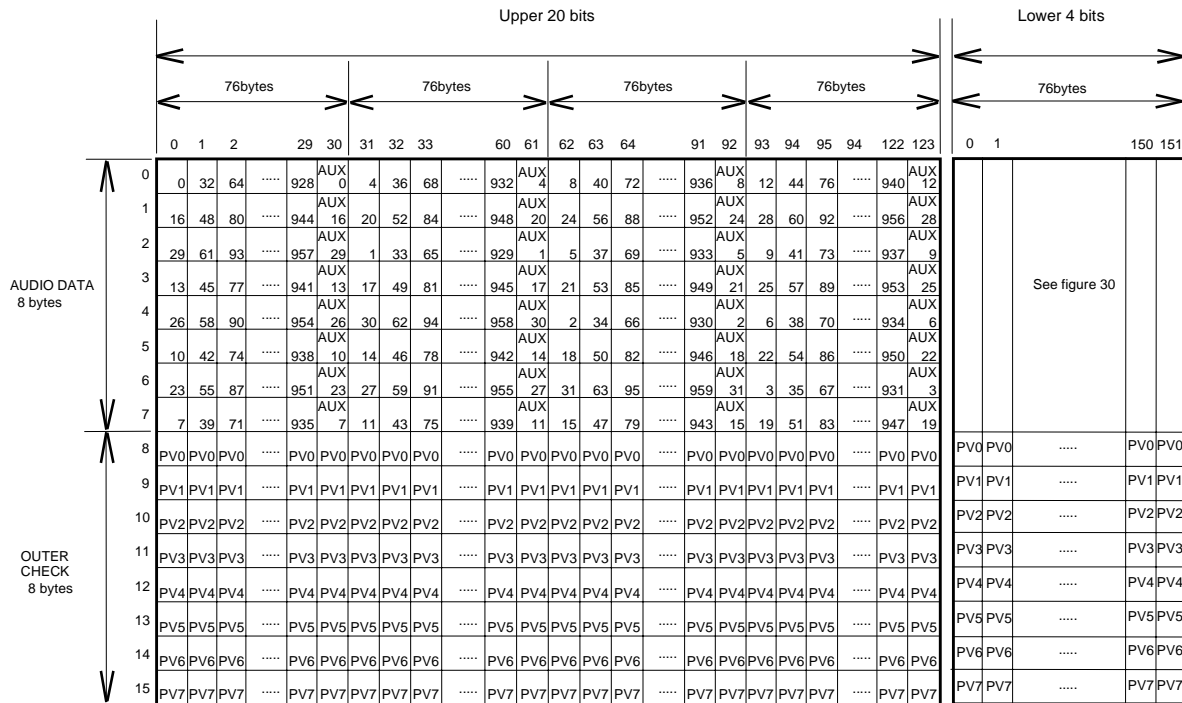

NOTES

1 Numeric table entries are audio sample numbers.

2 PV0 to PV7 represent outer check corresponding to audio data of each column.

Figure 30 – Audio data block layout (625/50 system)

	0	1	15	16	30	31	45	46	60	61	75	76	90	91	105	106	119								
0	0	8	120	128	240	248	360	368	480	488	600	608	720	728	840	848	952
1	484	492	604	612	724	732	844	852	4	12	124	132	244	252	364	372	476
2	841	849	1	9	121	129	241	249	361	369	481	489	601	609	721	729	833
3	365	373	485	493	605	613	725	733	845	853	5	13	125	133	245	253	357
4	722	730	842	850	2	10	122	130	242	250	362	370	482	490	602	610	714
5	246	254	366	374	486	494	606	614	726	734	846	854	6	14	126	134	238
6	603	611	723	731	843	851	3	11	123	131	243	251	363	371	483	491	595
7	127	135	247	255	367	375	487	495	607	615	727	735	847	855	7	15	119

	120	121	124	125	128	129	132	133	136	137	140	141	144	135	148	149	151								
0	AUX	AUX	AUX	AUX	AUX	AUX	AUX	AUX	AUX	AUX	AUX	AUX	AUX	AUX	AUX	AUX	AUX								
	0	8	32	40	64	72	96	104	128	136	160	166	192	200	224	232	248
1	AUX	AUX	AUX	AUX	AUX	AUX	AUX	AUX	AUX	AUX	AUX	AUX	AUX	AUX	AUX	AUX	AUX								
	132	140	164	172	196	204	228	236	4	12	36	44	68	76	100	108	124
2	AUX	AUX	AUX	AUX	AUX	AUX	AUX	AUX	AUX	AUX	AUX	AUX	AUX	AUX	AUX	AUX	AUX								
	225	233	1	9	33	41	65	73	97	105	129	137	161	169	193	201	217
3	AUX	AUX	AUX	AUX	AUX	AUX	AUX	AUX	AUX	AUX	AUX	AUX	AUX	AUX	AUX	AUX	AUX								
	101	109	133	141	165	173	197	205	229	237	5	13	37	45	69	77	93
4	AUX	AUX	AUX	AUX	AUX	AUX	AUX	AUX	AUX	AUX	AUX	AUX	AUX	AUX	AUX	AUX	AUX								
	194	202	226	234	2	10	34	42	66	74	98	106	130	138	162	170	186
5	AUX	AUX	AUX	AUX	AUX	AUX	AUX	AUX	AUX	AUX	AUX	AUX	AUX	AUX	AUX	AUX	AUX								
	70	78	102	110	134	142	166	174	198	206	230	238	6	14	38	46	62
6	AUX	AUX	AUX	AUX	AUX	AUX	AUX	AUX	AUX	AUX	AUX	AUX	AUX	AUX	AUX	AUX	AUX								
	163	171	195	203	227	235	3	11	35	43	67	75	99	107	131	139	155
7	AUX	AUX	AUX	AUX	AUX	AUX	AUX	AUX	AUX	AUX	AUX	AUX	AUX	AUX	AUX	AUX	AUX								
	39	47	71	79	103	111	135	143	167	175	199	207	231	239	7	15	31

Figure 31 – Audio data block layout – lower 4 bits (625/50 system)

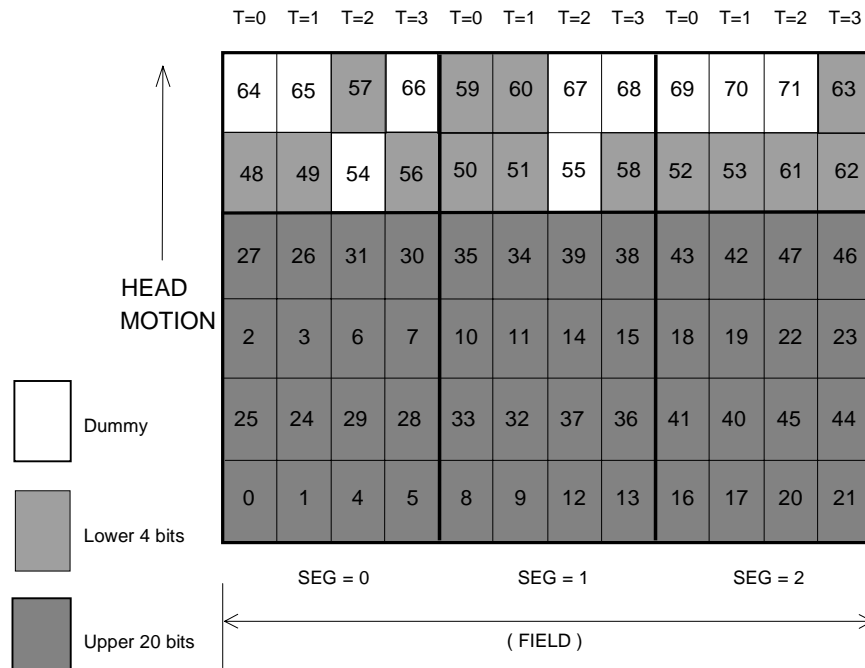

NOTES
 1 Numeric entries are audio sync block numbers.
 2 S = segment number (0, 1, 2).
 3 T = track number (0, 1, 2, 3,).

Figure 32 – Audio data block arrangement (525/60 system)

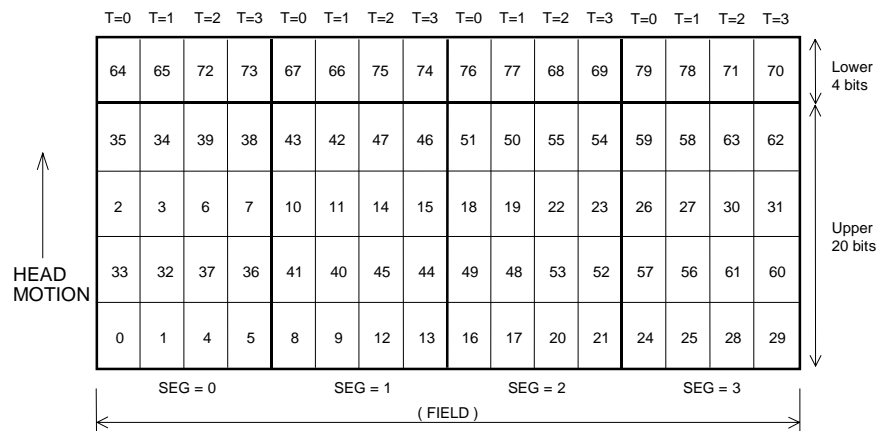

NOTES
 1 Numeric entries are audio sync block numbers.
 2 S = segment number (0, 1, 2, 3).
 3 T = track number (0, 1, 2, 3,).

Figure 33 – Audio data block arrangement (625/50 system)

10.3.6 Audio data word processing

Input data are formed into words of 24 bits in the sequence. 24 bits data are separately processed as upper 20 bits data and lower 4 bits data:

a) Assignment of the 24-bit word to audio data and associated data is controlled by user input (see table 11).

The most significant bit of the audio data word is bit 23 and unused bits of lower significance are removed. The auxiliary word LNGH (four bits) signals the word mode selected.

b) Each group of upper 20-bit words and lower 4-bit words is divided into 8-bit bytes as shown in figures 34 (525/60 system) and 35 (625/50 system) and arranged alternately by the MSB and the LSB of the first word of the word group.

c) Each group is distributed into the product block in accordance with figures 28 and 29 (525/60 system) and figures 30 and 31 (625/50 system).

d) For the 525/60 system, every fifth field shall contain 800 samples. All other fields shall contain 801 samples. The 5-field sequence of the number of audio data samples begins at an arbitrarily chosen field. Continuity of the 5-field sequence shall be preserved throughout the recording, including editing. The 5-field sequence is indicated by the value of the auxiliary word FNCT, as defined in 10.4.5. Furthermore, every fifth field of 800 samples is identified by the field address AF2 for audio data sync blocks, as defined in 6.3.3.

Table 11 – Audio data word mode

Word Mode	Bit					
	0-3	4	5	6	7	8-23
0 (0001)	Audio 0-3	C	U	V	R	Audio 4-20
1 (0011)	Audio 0-3	C	U	V	Audio 4	Audio 5-21
2 (0101)	Audio 0-3	C	V	Audio 4	Audio 5	Audio 6-22
3 (0111)	Audio 0-3	C	U	Audio 4	Audio 5	Audio 6-22
4 (1001)	Audio 0-3	C	Audio 4	Audio 5	Audio 6	Audio 7-23
5 (1011)	Audio 0-3	V	Audio 4	Audio 5	Audio 6	Audio 7-23
6 (1101)	Audio 0-3	U	Audio 4	Audio 5	Audio 6	Audio 7-23
7 (1111)	Audio 0-3 (LSB)	Audio 4	Audio 5	Audio 6	Audio 7	Audio 8-23

NOTES
 1 Example, "audio 1" represents bit 1 of audio sample.
 2 C = channel status bit, U = user bit, V = validity bit, R = reserved bit.
 3 Audio data will be rounded from the 20-bit length of the interface word (auxiliary data truncated) to the length above with the elimination of the least significant bit(s).
 4 Modes 0, 3, and 7 are the recommended modes for general use.

10.4 Auxiliary words

Auxiliary words are generated at the input interface from incoming data or user selection and serve to signal this information to the output interface. Auxiliary words are five words of four bits (525/60 system) or four words of four bits (625/50 system), plus one word of one bit and one word of eight bits as defined in figures 36 (525/60 system) and 37 (625/50 system). The word EFLG is written four times in each audio data block.

Figures 34 (525/60 system) and 35 (625/50 system) show the format of the auxiliary words in the audio data block.

Upper 20 bits

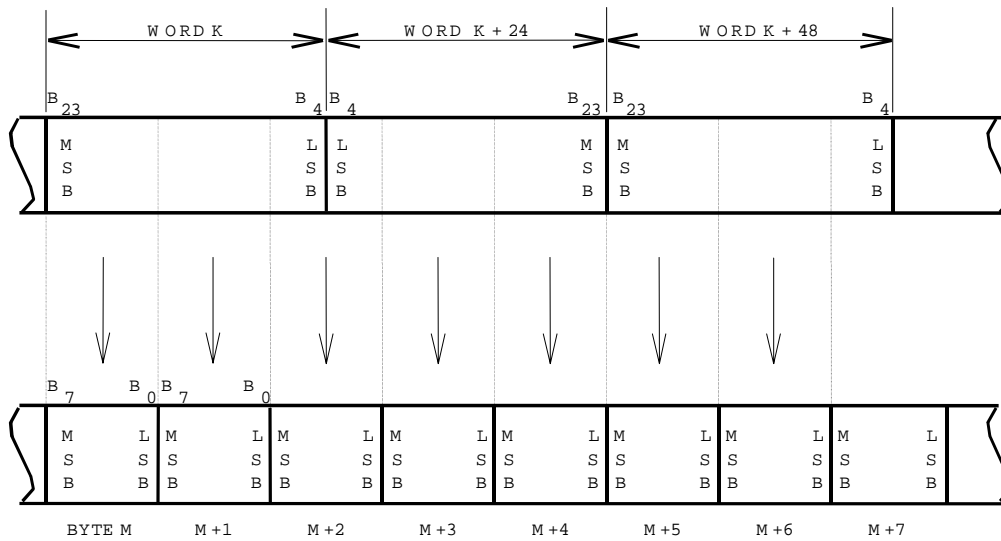

Lower 4 bits

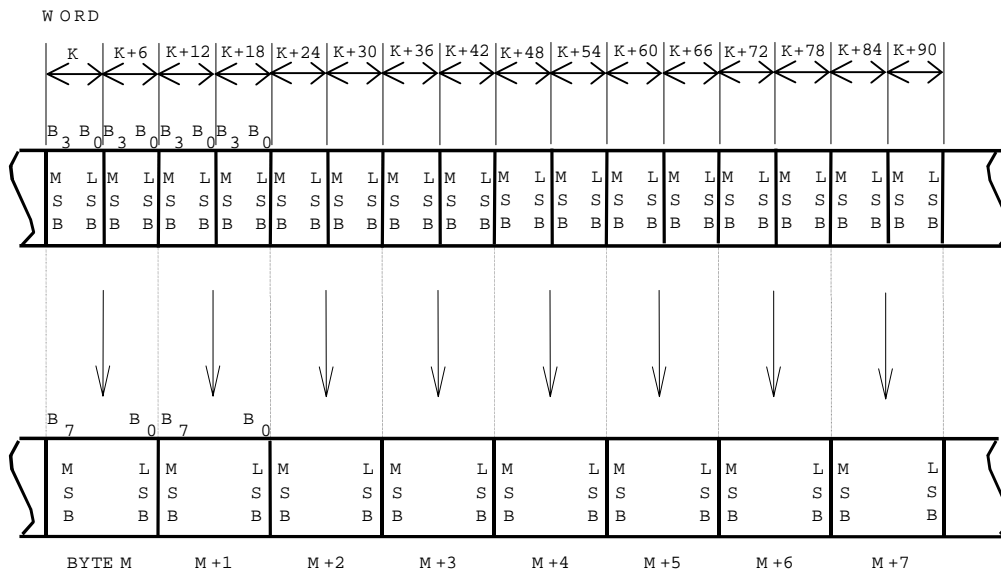

NOTE -K = 0, 9, 18, 4, 13, 22, 8, and 17 in figure 28.

Figure 34 – Digital audio data word to byte conversion (525/60 system)

Upper 20 bits

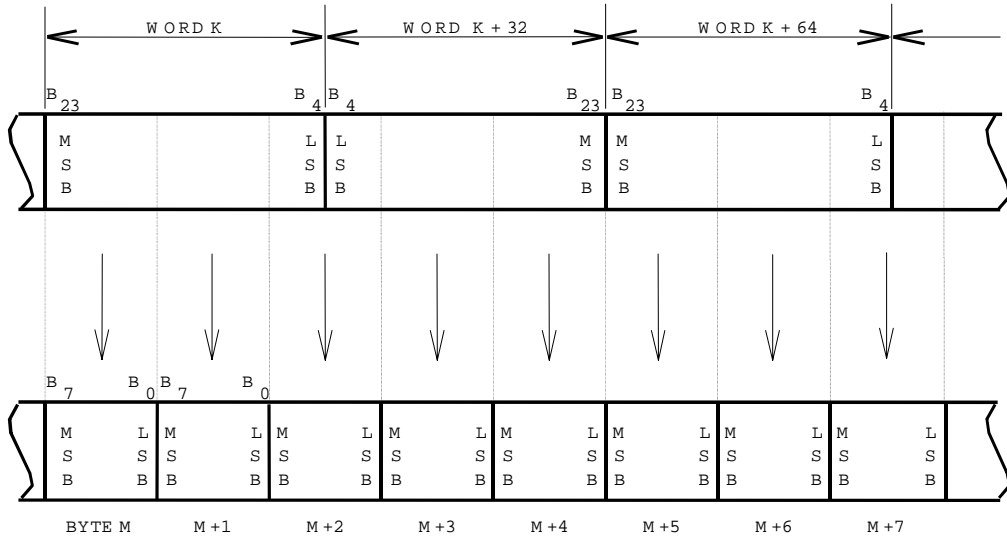

Lower 4 bits

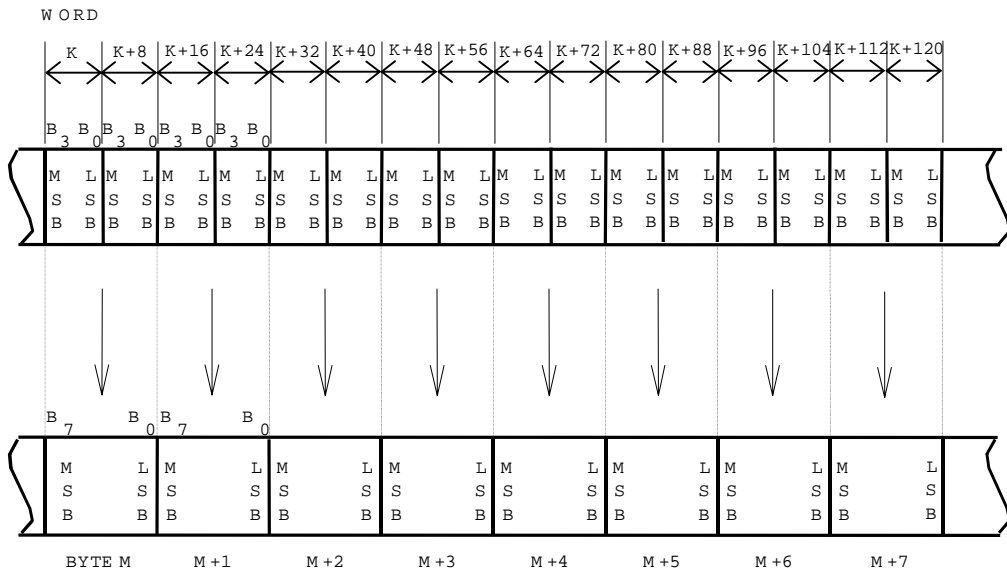

NOTE -K = 0,16,29,13,26,10,23, and 7 in figure 30

Figure 35 – Digital audio data word to byte conversion (625/50 system)

AUX DATA (upper 20 bits)

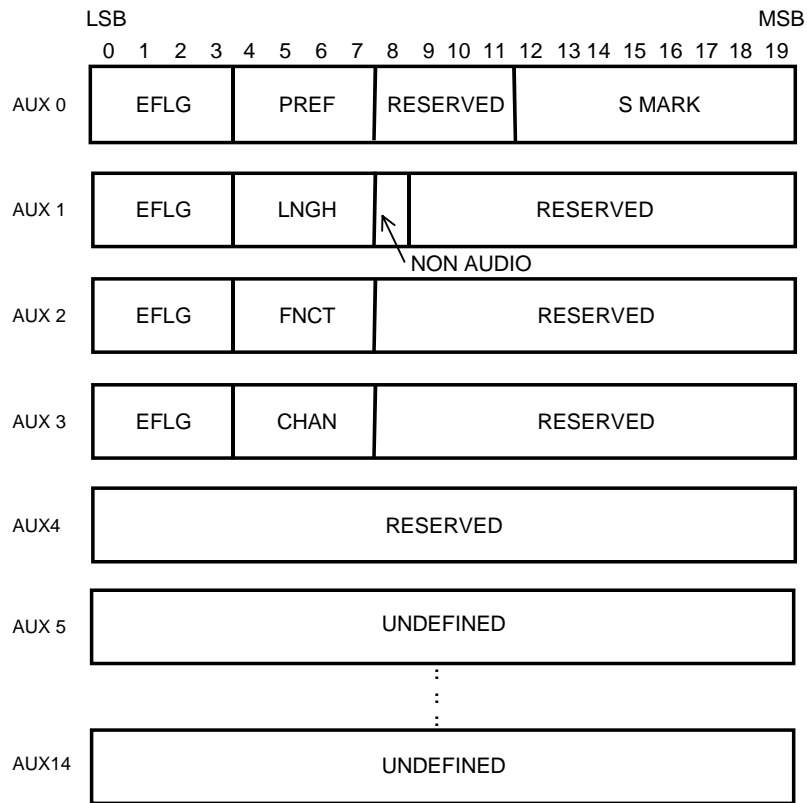

NOTE - Reserved = 0_h or 000_h or 0000_h.

AUX DATA (lower 4 bits)

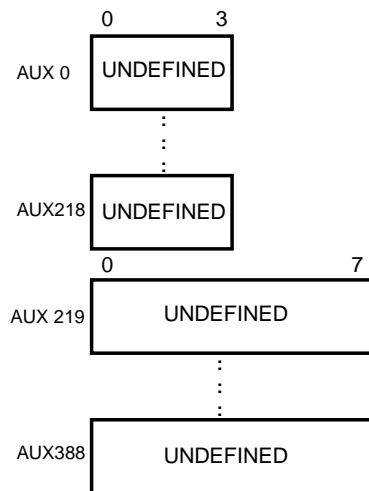
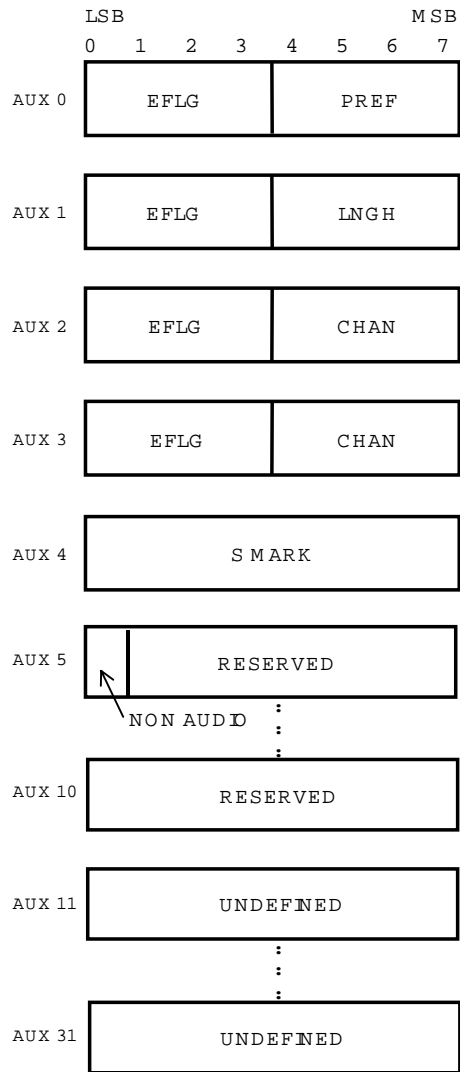

Figure 36 – Audio data block auxiliary data (525/60 system)

AUX DATA (upper 20 bits)



NOTE -Reserved = 00_h.

AUX DATA (lower 4 bits)

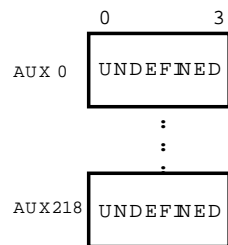
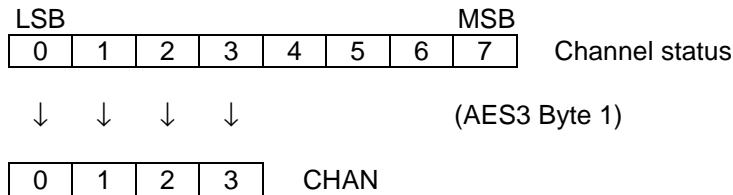

Figure 37 – Audio data block auxiliary data (625/50 system)

10.4.1 Channel use (CHAN)

This word is four bits and specifies the usage of the two input channels in an interface data stream. CHAN is derived from channel status byte 1. CHAN is inserted in bits 4-7 of AUX 3 (525/60 system) or bits 4-7 of AUX 2 (625/50 system). (See table 12, figures 36 and 37.)



- Bit 0: Channel mode bit 0
- Bit 1: Channel mode bit 1
- Bit 2: Channel mode bit 2
- Bit 3: Channel mode bit 3

Table 12 – Channel use control word

Mode	CHAN bit				Value
	0	1	2	3	
0	0	0	0	0	2 channel-default
1	0	0	0	1	2 channel
2	0	0	1	0	Single channel
3	0	0	1	1	Primary/secondary 2 channel
4	0	1	0	0	Stereophonic
5	0	1	0	1	Undefined
F	1	1	1	1	Undefined

10.4.2 Preemphasis (PREF)

This word is four bits and specifies the usage of preemphasis in the audio data coding. PREF is derived from channel status byte 0. PREF is inserted in bits 4-7 of AUX 0 (see table 13, figures 36 and 37).

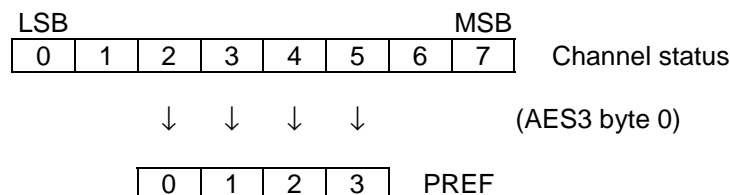

- Bit 0: Preemphasis bit 0
- Bit 1: Preemphasis bit 1
- Bit 2: Preemphasis bit 2
- Bit 3: 0

Table 13 – Preemphasis control word

Mode	PREF bit			Value
	0	1	2	
0	0	0	0	Preemphasis off – (default)
1	0	0	1	Reserved
2	0	1	0	Reserved
3	0	1	1	Reserved
4	1	0	0	Preemphasis off
5	1	0	1	Reserved
6	1	1	0	50/15 microsecond (CD type)
7	1	1	1	Reserved

10.4.3 Audio data word mode (LNGH)

This word is four bits and specifies the audio data word length and the usage of the ancillary bits status, user, and validity. LNGH is derived from user control inputs and inserted in bits 4-7 of AUX 1 (see table 14, figures 36 and 37).

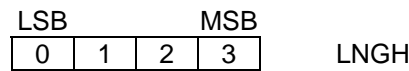

- Bit 0: LNGH 0 (LSB)
- Bit 1: LNGH 1
- Bit 2: LNGH 2
- Bit 3: LNGH 3 (MSB)

Table 14 – Word mode control word

Mode	LNGH bit				Audio data Length	Ancillary bits			
	3	2	1	0		C	U	V	R
0	0	0	0	1	20 bits	X	X	X	X
1	0	0	1	1	21 bits	X	X	X	-
2	0	1	0	1	22 bits	X	-	X	-
3	0	1	1	1	22 bits	X	X	-	-
4	1	0	0	1	23 bits	X	-	-	-
5	1	0	1	1	23 bits	-	-	X	-
6	1	1	0	1	23 bits	-	X	-	-
7	1	1	1	1	24 bits	-	-	-	-

NOTE – "X" means the ancillary bit is recorded.

10.4.4 Block sync location (S MARK)

S MARK is an 8-bit word. S MARK specifies the location of the block sync associated with channel status and user data, as defined in AES3. S MARK contains the word count, in the current block, of the first block sync detected; i.e., the word address in the block pointing to the first sample after the block sync mark.

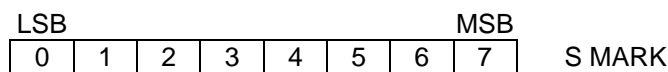

where S MARK is from 00_h to BF_h inclusive.

S MARK = FF_h if no mark is found within the defined range.

S MARK is inserted in bits 12-19 of AUX 0 (525/60 system, see figure 36) or bits 0-7 of AUX 4 (625/50 system, see figure 37).

10.4.5 Field number count (FNCT)

In the 525/60 system, this word is four bits and specifies the number of audio data samples in the current field. FNCT is inserted in bits 4-7 of AUX 2 (see table 15, figures 36 and 37).

LSB		MSB		
0	1	2	3	FNCT

Bit 0: FNCT 0 (LSB)
 Bit 1: FNCT 1
 Bit 2: FNCT 2 (MSB)
 Bit 3: 0

Table 15 – FNCT mode

Number of samples	FNCT bit		
	2	1	0
801	0	0	0
801	0	0	1
801	0	1	0
801	0	1	1
800	1	0	0

10.4.6 Edit flag (EFLG)

This word is four bits and specifies the field associated with an edit transition. EFLG is inserted in bits 0-3 of AUX 0, AUX 1, AUX 2, and AUX 3 (see figures 36 and 37).

LSB		MSB		
0	1	2	3	EFLG

For 525/60 system:

EFLG = D_h for the first field of the edit

EFLG = 7_h for the last field of the edit

EFLG = 0_h otherwise

For 625/50 system:

EFLG = B_h for the first field of the edit

EFLG = E_h for the last field of the edit

EFLG = 0_h otherwise

10.4.7 Non-audio data flag (NON AUDIO)

This word is one bit and specifies whether the data is audio or non-audio(data). NON AUDIO is inserted in bit 8 of AUX 1 (525/60 system, see figure 36) or bit 0 of AUX 5 (625/50 system, see figure 37).

NON AUDIO = 0 audio data

NON AUDIO = 1 non audio data

10.5 Outer error protection

Rows 8 through 15 of the data block, as shown in figures 28 (525/60 system) and 30 (625/50 system) contain the error check bytes associated with each column.

Type: Reed-Solomon.

Galois field: GF(256).

Field generator polynomial:

$$x^8 + x^4 + x^3 + x^2 + 1,$$

where x^i are place-keeping variables in GF(2), the binary field.

Order of use: Left-most term is the most significant, "oldest" in time computationally, and first written to tape.

Code generator polynomial:

$$G(x) = (x+1)(x+a)(x+a^2)(x+a^3)(x+a^4)(x+a^5)(x+a^6)(x+a^7),$$

where a is given by 02_h in GF(256).

Check characters: $K_7, K_6, K_5, K_4, K_3, K_2, K_1, K_0$ (also identified respectively as $PV_7, PV_6, PV_5, PV_4, PV_3, PV_2, PV_1, PV_0$) in $K_7x^7 + K_6x^6 + K_5x^5 + K_4x^4 + K_3x^3 + K_2x^2 + K_1x + K_0$

obtained as the remainder after dividing the polynomial $x^8D(x)$ by $G(x)$, where $D(x)$ is the polynomial given by $D(x) = B_7x^7 + B_6x^6 + B_5x^5 + \dots + B_1x + B_0$.

Polynomial of full code:

$$B_7x^{15} + B_6x^{14} + B_5x^{13} + \dots + B_1x^9 + B_0x^8 + K_7x^7 + K_6x^6 + \dots + K_2x^2 + K_1x + K_0.$$

Outer-code check characters in each column of the $85 \times 4 \times 8$ blocks (525/60 system) or $76 \times 5 \times 8$ blocks (625/50 system) are calculated using the data order existing prior to the rearrangement into the pattern shown in figures 28 (525/60 system) and 30 (625/50 system); i.e., in ascending sample order.

The check characters K_7 through K_0 are used as the vertical protection characters identified as PV_7 through PV_0 , respectively.

10.6 Inner protection

The inner protection and sync block formats are identical to those for video (see 6.3 and 6.4).

10.7 Order of transmission to inner coding

Audio data bytes (outer check bytes considered as data) are sent to the inner coder after the block shuffling.

10.8 Channel code

The channel code is identical to that for video (see 6.5).

10.9 Allocation of audio data sectors

The data blocks of an audio data channel are arranged in three groups of four sectors (12 sectors) as shown in figure 32 (525/60 system) or four groups of four sectors (16 sectors) as shown in figure 33 (625/50 system). A group of six (525/60 system) or five (625/50 system) sectors from each of the eight audio data channels is recorded according to figures 38 (525/60 system) and 39 (625/50 system). Audio data sectors labeled from Ac1 to Ac8 correspond to audio input channels from one to eight, respectively.

For the 525/60 system, the allocation of a group of sectors is a four-field sequence. The field address AF_0 , AF_1 of the sector ID of six (525/60 system) or five (625/50 system) audio data sync blocks is defined in 6.3.3.

11 Longitudinal tracks

11.1 Relative timing

11.1.1 Time and control code input

An external time and control code input signal that meets the specifications described in SMPTE 12M, or a time and control code that is internally generated within the recorder, shall be timed for recording in a following way. The relationship between the "start of address" of the time and control code and the program reference point of a track with an even-field address (count) for the compressed video data, is as defined by figure 4 and tables 1 and 2.

Time code signal timing relative to video signal timing at the output interface during playback shall be the same (temporal skew is equal to zero) as it was at the input interface during recording.

11.1.2 Time and control code information

The time and control code information shall refer to the video frame during which it is recorded.

11.1.3 Cue information

Cue information shall be recorded on the tape at a point referenced to the associated video information as defined by dimension P2 of figure 4, and tables 1 and 2.

11.1.4 Control track servo pulse

Control track servo pulse record timing is described in 11.2.

11.2 Control track

11.2.1 Recording method

The control track shall be recorded using the hysteresis (direct recording) method.

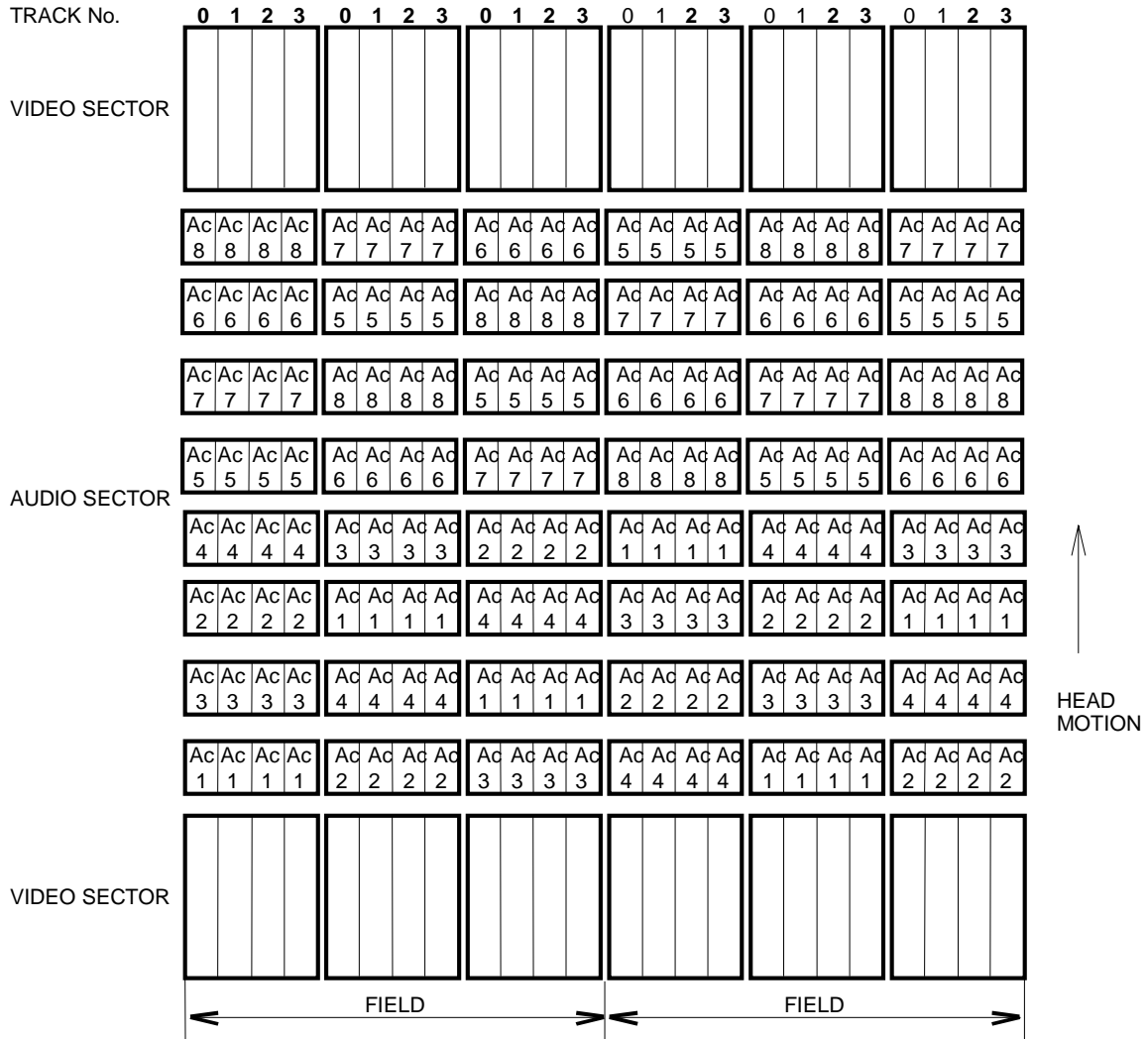

Figure 38 – Audio data channel arrangement (525/60 system)

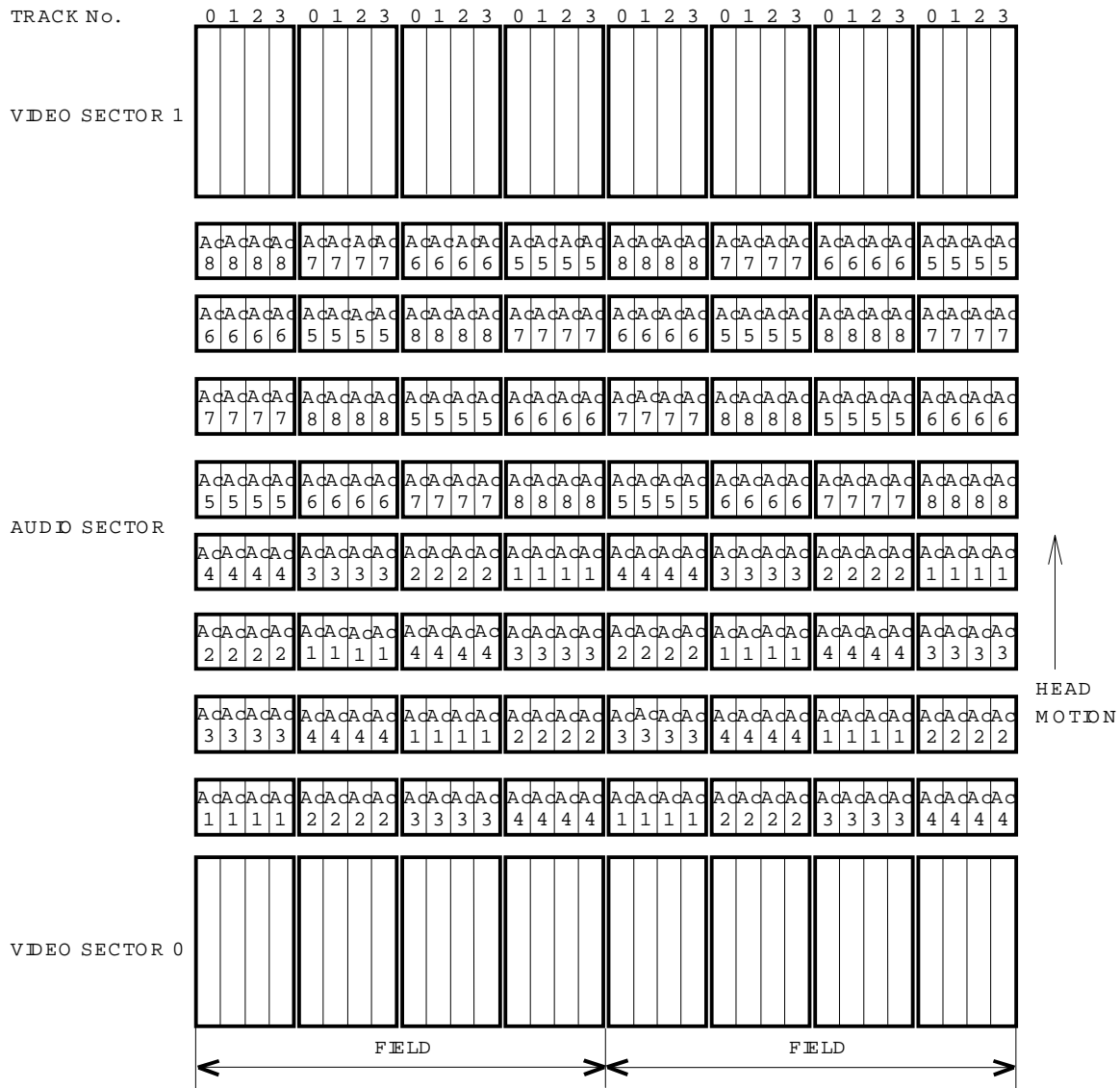

Figure 39 – Audio data channel arrangement (625/50 system)

11.2.2 Servo reference pulse

The control track servo reference pulse, at the time of recording, shall be a series of pulses with a period of $11.122 \text{ ms} \pm 6 \text{ } \mu\text{s}$ as shown in figure 40 (525/60 system) or $10.000 \text{ ms} \pm 6 \text{ } \mu\text{s}$ as shown in figure 41 (625/50 system).

11.2.3 Flux polarity

The polarities of the recorded flux shall be as shown in figure 4.

11.2.4 Flux level

The recording shall attenuate any previous recording by at least 30 dB.

11.2.5 Pulse width

The recorded pulses shall have periods of 3T, 4T, 5T, 6T, or 7T where T equals 1.1122 ms nominal (525/60 system) or 1.000 ms nominal (625/50 system). The rise and fall times of the record current (10% to 90% points) shall be less than 150 μs .

11.2.6 Servo reference pulse timing

The servo reference pulses and the data of the program reference point, when recorded according to figure 4, shall occur at the same time.

11.2.7 Color frame pulse

A color frame sequence at the time of the start of each recording shall be indicated by a pulse rising transition point that follows a sequence of 6T-4T duration pulses. The color frame commences with color frame A field 1. It shall be located at the rising point after the 6T-4T duration pulses, coinciding with a segment count and a field count of zero in the video sector identification pattern, as defined in 6.3.3.

NOTE – Color frame information of an input composite signal is recorded on a tape to support the decoding and encoding process if the implemented recorder supports such an interface.

11.2.8 Video frame pulse

The first segment of a video frame at the time of the start of each recording shall be indicated by a pulse rising transition point that follows a sequence of 6T-4T or 4T-6T duration pulses. It shall be located at the rising points after the 6T-4T or 4T-6T duration pulses, coinciding with a segment count and an even field count of zero in the video sector identification pattern, as defined in 6.3.3.

11.2.9 Number of audio data channel identification

Eight audio data channels recording shall be indicated by a sequence of 3T-7T pulses. These shall be located after the 6T-4T or 4T-6T duration pulses¹⁾ (see figure 40 and 41).

NOTE – The sequence of 3T-7T pulses is unique to eight audio data tracks recording and it may be used as a method for detection and differentiation of a D5 recording with 4 audio data tracks.

11.3 Cue record

11.3.1 Recording method

The signals shall be recorded using the anhysteresis (ac bias) method.

11.3.2 Flux level

The recorded reference audio data level shall correspond to an rms magnetic short circuit flux level of 125 nWb/m \pm 3 nWb/m of track width at 1000 Hz.

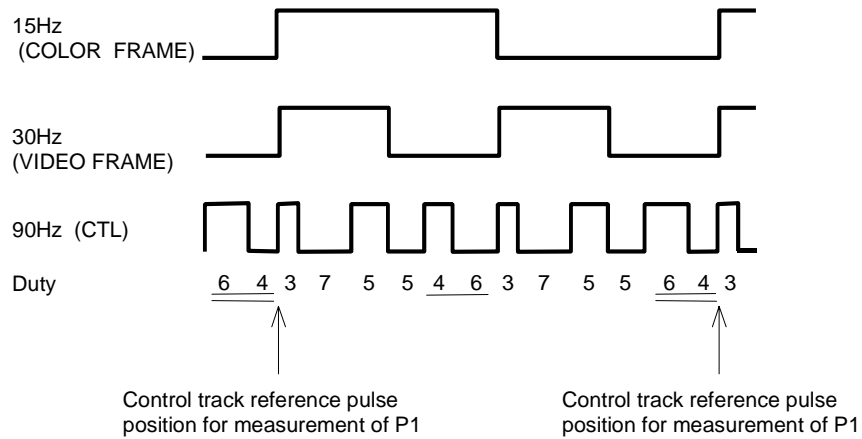

Figure 40 – Recorded control record waveform timing (525/60 system)

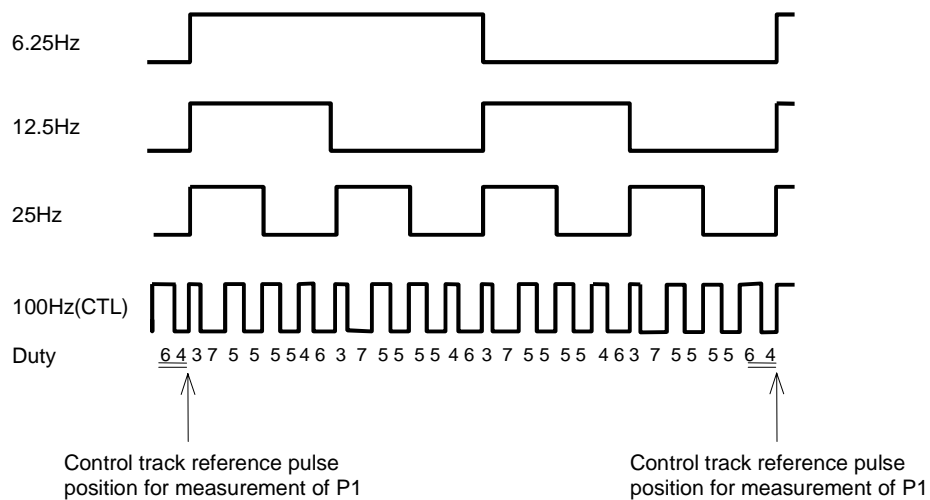

Figure 41 – Recorded control record waveform timing (625/50 system)

11.4 Time and control code record

11.4.1 Recording Method

The signals shall be recorded using the anhysteresis (ac bias) recording method.

11.4.2 Flux level

The recorded peak-to-peak flux shall correspond to a magnetic short circuit flux level of $250 \text{ nWb/m} \pm 20 \text{ nWb/m}$ of track width.

11.4.3 Input signal

The signal recorded on this track shall be in accordance with SMPTE 12M.

Annex A (normative)

Tape tension

The value measured with a tension monitor on the entrance side of the scanner may vary among manufacturers, but would typically be $0.31 \text{ N} \pm 0.05 \text{ N}$.

Annex B (normative)

Cross-tape track measurement technique

The cross-tape measuring technique utilizes the fact that all tracks of a helical-scan video recording, recorded by the same head at constant tape speed, have the same longitudinal track pitch, the same track angle, and the same track curvature.

From a ferrofluid development, measurements are made of the actual track positions and the distance between a minimum of 200 control track pitches. All measurements shall be made under the environmental conditions described in 3.1, except that the measurements are made without tape tension (see table B.1). The tape is then mathematically stretched to account for tape tension (see figure B.1). The theoretical track position is calculated from the corrected longitudinal track pitch and the theoretical track angle. The track location error is calculated as the difference between the theoretical track position and the actual track position (see table B.1 and figure B.3).

Track location error, which is expressed by the lower edge error of the tracks, includes track angle errors, track straightness errors, and track pitch errors. The starting point for calculations and measurements is, for example, the cross point of the lower edge of the track containing the program reference point and the line along the measurement path in figure B.2. The values for each eighth track are the errors for tolerance zone one. Shifting one track, the second tolerance zone can be measured and so on. It is not necessary to measure all tracks; a suitable number can be 20 samples per zone. A plot of the track location error against the track number must be computed (see figure B.3). The peak-to-peak value shall lie within the tolerance zones specified in 5.3.

Table B.1 – Nomenclature and calculation of track location error

		525/60 system	625/50 system
Y ₀	Program area reference (basic)	1.640 mm	1.756 mm
θ	Track angle (basic)	4.9384°	
T	Tension	0.31 N	
E	Young's modulus	8 000 N/mm ²	
A	Cross sectional area	Thickness × Width	
CTM	Distance of n control track pitches without tape tension		
CTM'	Distance of n control track pitches with tape tension	CTM' = CTM(1+ T/(A × E))	
g	Longitudinal track pitch	g= CTM'/4n	
i	Track number, i = 0 for track containing reference point		
Y _i	Measured position of track i at the recorded pattern		
Δ Y	Cross section track pitch	Δ Y = g × tan θ	
Y _{it}	Theoretical position of track i at the recorded pattern	Y _{it} = Y ₀ + i × Δ Y	
l	Track pitch	l = g × sin θ	
TLE	Track location error	TEL = Y _i - Y _{it}	
Z	Tolerance zone	Z4 = 0.004 mm Z1, Z2, Z3, Z5, Z6, Z7, Z8 = 0.006 mm	
NOTE – For tolerance zone Z1: i = ... -8, 0, +8, +16, ... Z2: i = ... -9, -1, +7, +15, ... Z3: i = ... -10, -2, +6, +14, ... Z4: i = ... -11, -3, +5, +13, ... Z5: i = ... -12, -4, +4, +12, ... Z6: i = ... -13, -5, +3, +11, ... Z7: i = ... -14, -6, +2, +10, ... Z8: i = ... -15, -7, +1, +9, ...			

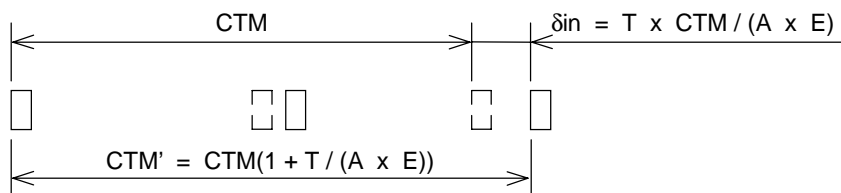
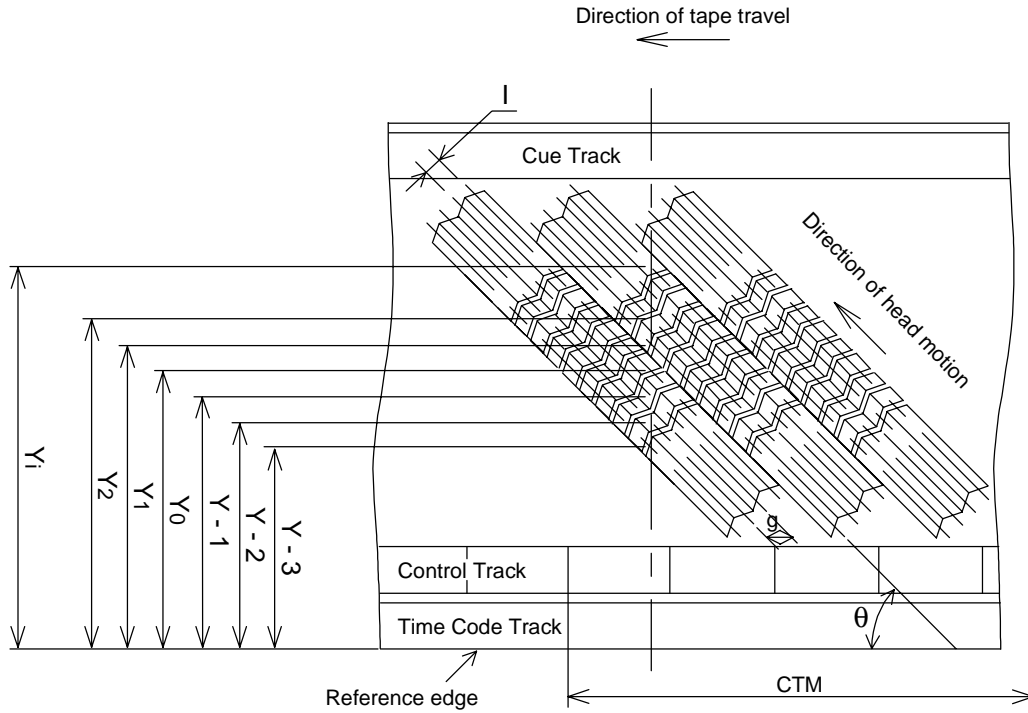

Figure B.1 – Correction factors (actual tape speed and tension)



NOTE – The same head must be used for Y_i measurement (i.e., every eighth track); CTM is the distance of n control track pitches ($n = 200$ minimum).

Figure B.2 – Cross-tape measurement technique

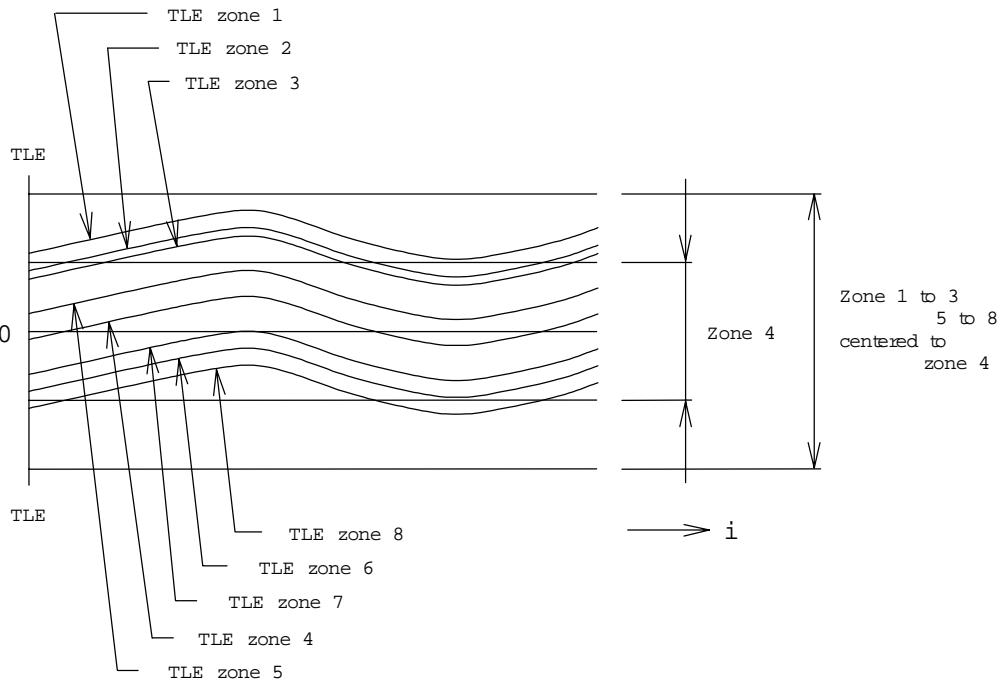
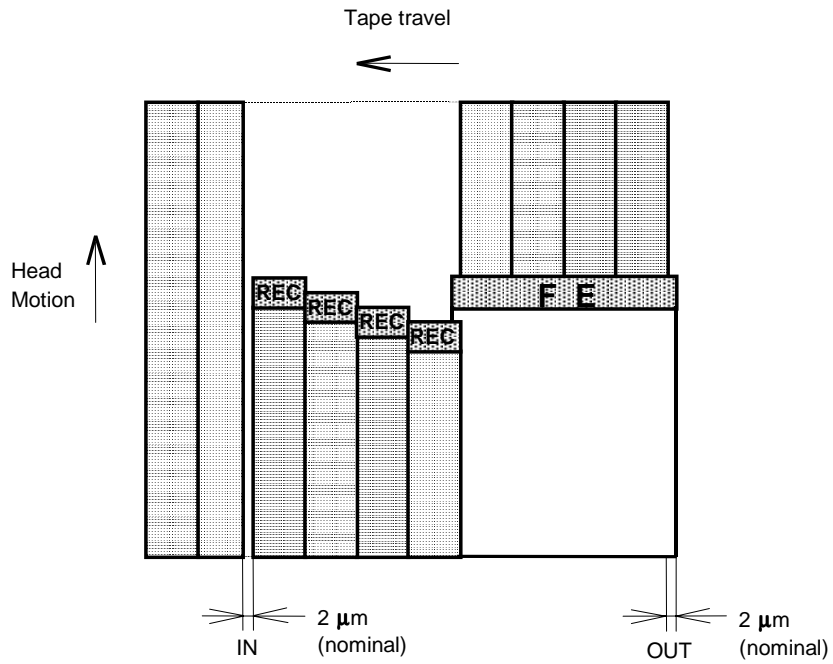

Figure B.3 – Track location error plot (example)

Annex C (normative)
Track pattern during insert editing

A guard band of 2 μm (nominal) at editing points only is shown in figure C.1.



NOTES - 1 REC is a recording head.
 2 FE is a flying erase head.

Figure C.1 – A typical pattern during insert editing

Annex D (informative)
Recorded block diagram contained in this document

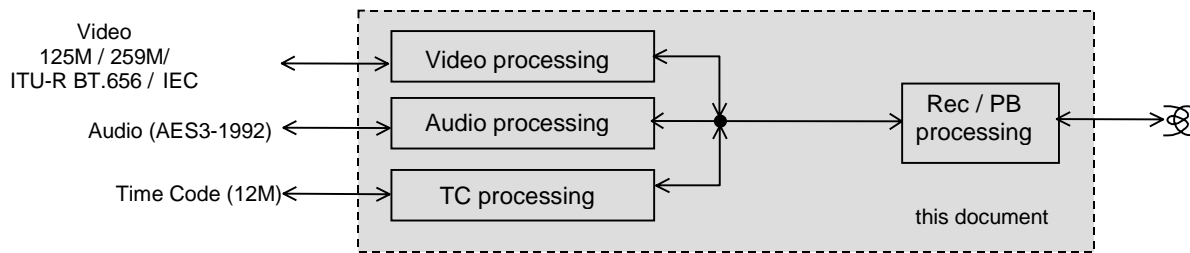

Figure D.1 – Recorder block diagram contained in this document

Annex E (informative)
Reference and calibration tape

Blank tape for reference recordings should be available from any source meeting the tape characteristics as defined by this standard.

The calibration tapes meeting the requirements of 3.3.1 and 4 should be available from manufacturers who produce DTTs and players in accordance with this standard. Tolerances of the record locations and dimensions shown in tables 1 or 2 will be reduced by 50 %.

Two sets of signals should be recorded on the calibration tape:

- a) Video: 100% color bars
 Audio: 1-kHz tone at 20 dB below full scale on each of the audio data channels
 Cue: 1-kHz tone at reference level; 10-kHz tone at reference level

- b) A signal of constant recorded frequency (i.e., one half the Nyquist frequency) only on tracks of field 0, segment 0 for the purpose of mechanical alignment. Recording level should conform to 6.6.3.

Annex F (informative)
Tape cassette

Tape enclosure (tape cassette) is specified in SMPTE 263M.

Annex G (informative)
Abbreviations

AUX	Auxiliary
CHAN	Channel use
D5	Recording format described by SMPTE 279M
EFLG	Edit flag
FNCT	Field number count
LNGH	Audio data word mode
PREF	Preemphasis
S MARK	Block sync location

Annex H (informative)
Bibliography

ANSI/SMPTE 125M-1995, for Television — Component Video Signal 4:2:2 - Bit-Parallel Digital Interface

SMPTE 263M-2003, Television Digital Recording — 1/2-in Type Magnetic Tape Cassette

SMPTE 264M-1998, Television Digital Recording — 1/2-in Type D-3 Composite Format — 525/60

SMPTE 265M-1997, Television Digital Recording — 1/2-in Type D-3 Composite Format — 625/50

SMPTE EG 21-1993, Nomenclature for Television Digital Recording of 19-mm Type D-1 Component and Type D-2 Composite Formats

CCITT Vol. III, Fascicle III.4, Transmission of Sound-Programme and Television Signals, Recommendation J.17, Pre-emphasis

IEC 60735 (1991-11), Measuring Methods for Video Tape Properties

IEC 61179 (1993-03), Helical-Scan Digital Composite Video Cassette Recording System Using 19 mm Magnetic Tape, Format D2 (NTSC, PAL, PAL-M)

ISO 2110:1989, Information Technology — Data Communication — 25-Pole DTE/DCE Interface Connector and Contact Number Assignments

ITU-R BT.470-6(11/98), Conventional Television Systems

ITU-R BT.601-5(10/95), Studio Encoding Parameters of Digital Television for Standard 4:3 and Wide-Screen 16:9 Aspect Ratios

ITU-R BT.656-4(02/98), Interfaces for Digital Component Video Signals in 525-Line and 625-Line Television Systems Operating at the 4:2:2 Level of Recommendation ITU-R BT.601 [Part A]