Proposed SMPTE Standard for Television

Date: <2005-12-12>

TP Rev 0

SMPTE 424M-2005

SMPTE Technology Committee N 26 on File Management and Networking Technology

SMPTE STANDARD-

--- 3 Gb/s Signal/Data Serial Interface

Warning

This document is not a SMPTE Standard. It is distributed for review and comment. It is subject to change without notice and may not be referred to as a SMPTE Standard. Recipients of this document are invited to submit, with their comments, notification of any relevant patent rights of which they are aware and to provide supporting documentation. Distribution does not constitute publication.

Contents

Page

1 Scope	3
2 Normative References	3
3 Source data	3
4 Parallel data format.....	4
5 Serial data format.....	4
6 Coaxial cable interface	5
Annex A (informative) Channel code	8
Annex B (Informative) Receiver Type	9
Annex C (informative) Generator polynomial implementations-	10
Annex D (informative) Bibliography	11
Annex E (informative) Document roadmap	12

Foreword

SMPTE (the Society of Motion Picture and Television Engineers) is an internationally-recognized standards developing organization. Headquartered and incorporated in the United States of America, SMPTE has members in over 80 countries on six continents. SMPTE's Engineering Documents, including Standards, Recommended Practices and Engineering Guidelines, are prepared by SMPTE's Technology Committees. Participation in these Committees is open to all with a bona fide interest in their work. SMPTE cooperates closely with other standards-developing organizations, including ISO, IEC and ITU.

SMPTE Engineering Documents are drafted in accordance with the rules given in Part XIII of its Administrative practices.

SMPTE Standard 424M was prepared by Technology Committee N 26.

3Gb/s Signal/Data Serial Interface

1 Scope

1.1 This standard is a transport defining a bit-serial data structure for 3 Gb/s [nominal] component digital signals or packetized data.

1.2 This standard specifies a coaxial cable interface suitable for applications where the signal loss does not exceed an amount specified by the receiver manufacturer. Typical loss amounts would be in the range of up to 20 dB at one-half the clock frequency.

2 Normative References

The following standards contain provisions which, through reference in this text, constitute provisions of this standard. At the time of publication, the editions indicated were valid. All standards are subject to revision, and parties to agreements based on this standard are encouraged to investigate the possibility of applying the most recent edition of the standards indicated below.

SMPTE 425M-2005, -3Gb/s Signal/Data Serial Interface – Source Image Format Mapping

IEC 60169-8, Sections A.2 and A.3, "Amendment 2, Radio-frequency connectors Part 8: R.F. coaxial connectors with inner diameter of outer conductor 6,5 mm (0,256 in) with bayonet lock – Characteristics impedance 50 ohms (type BNC) ¹ "

SMPTE RP 184-1996, Specification of Jitter in Bit Serial Digital Systems

3 Source data

3.1 For this interface, the source data shall be a virtual interface consisting of two 10-bit parallel data streams – data stream one and data stream two.

The virtual interface shall be constructed in accordance with SMPTE 425M – 3 Gb/s Signal/Data serial interface – Source Image Format Mapping.

3.2 Data for each line of data stream one and data stream two of the virtual interface are divided into four areas: EAV (end of active line) timing reference; the digital blanking area; SAV (start of active video) timing reference; and the digital active line as shown in figure 1.

The number of words and defined data in each area are specified by SMPTE 425M and the source image format document.

¹ Please note that the title of this normative reference may be misleading. This standard requires the use of the 75 ohm connector defined in this reference.

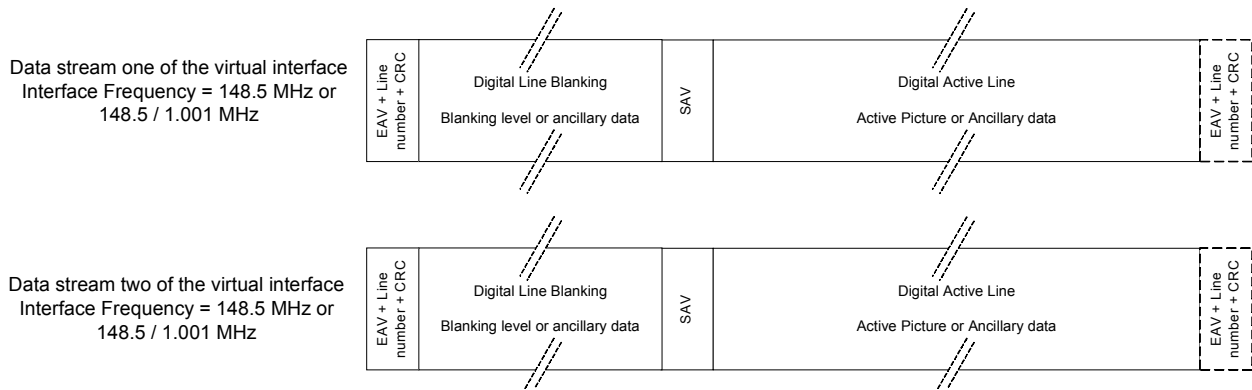

Figure 1 Virtual interface digital line data areas

4 Parallel data format

4.1 The 10-bit data words of parallel data stream one and data stream two of the virtual interface, are shown in figure 2.

By way of example, figure two illustrates the mapping of 274M 4:2:2 (Y'C_BC_R)/10-bit signals at 60 or 60/1.001 Frame Rates. Other frame rates, image formats, sampling structures and pixel depths are supported by this interface as defined in SMPTE 425M.

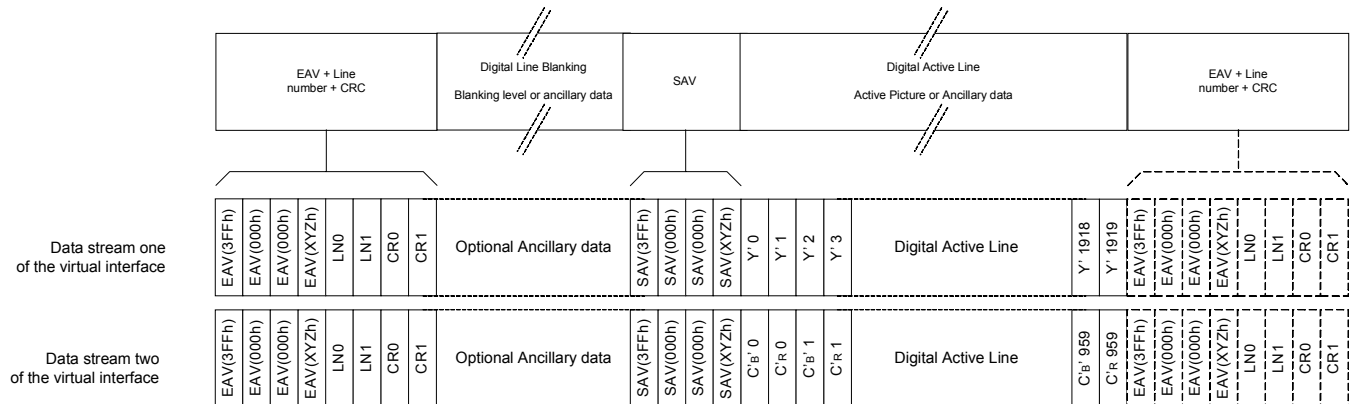

Figure 2 Example parallel data format for data stream one and data stream two of the virtual interface

5 Serial data format

The two parallel data streams of the virtual interface are transmitted over a single channel in bit-serial form after word-multiplexing, parallel-to-serial conversion and scrambling have been applied.

5.1 Data stream one and data stream two of the virtual interface shall be multiplexed word-by-word into a single 10-bit parallel stream in the order: data stream two; data stream one; data stream two.....etc, as shown in figure 3.

The single 10-bit parallel interface so produced shall have an interface frequency of 297 MHz or 297/1.001 MHz, or two times the virtual interface frequency defined in SMPTE 425M.

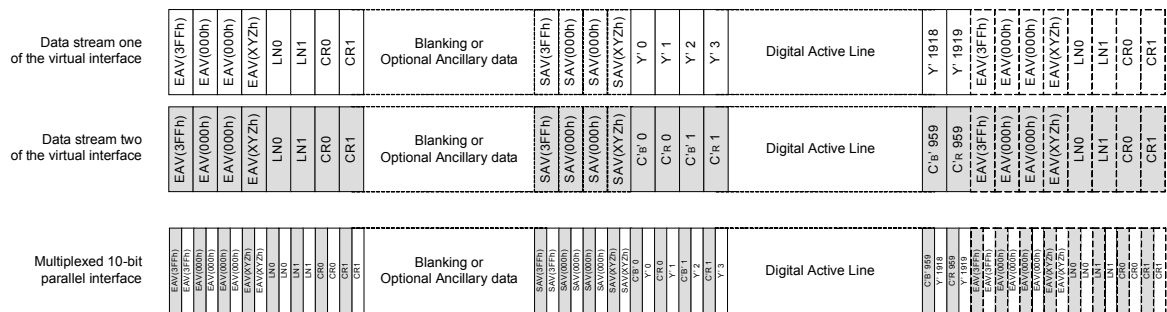

Figure 3 10-bit multiplex of data stream one and data stream 2

5.2 Multiplexed data shall be serialized with the LSB (least significant bit) of each data word transmitted first at a serial data rate of 2.97 Gb/s or 2.97/1.001 Gb/s.

5.3 The channel coding scheme shall be scrambled NRZI (non-return to zero inverted). (See annex A.)

5.4 The generator polynomial for the scrambled NRZ shall be $G_1(X) = X^9 + X^4 + 1$. Polarity-free scrambled NRZI sequence data shall be produced by the generator polynomial $G_2(X) = X + 1$. The input signal to the scrambler shall be positive logic, where the highest voltage represents data 1 and the lowest voltage represents data 0 (see annex C).

6 Coaxial cable interface

6.1 Signal levels and specifications

These specifications are defined for measurement of the serial output of a source derived from a parallel domain signal.

All measurements shall be made as defined in § 6.1.1.

6.1.1 The output of the generator shall be measured across a 75-ohm resistive load connected through a 1 meter coaxial cable and 75 ohm BNC connectors meeting the requirements defined in § 6.2. Figure 4 depicts the measurement dimensions for amplitude, rise-time and overshoot.

6.1.2 The generator shall have an unbalanced output circuit with a source impedance of 75 ohms and a return loss of at least 15 dB over the frequency range of 5 MHz to $\frac{1}{2}$ the clock frequency and at least 10 dB over the frequency range $\frac{1}{2}$ the clock frequency up to the clock frequency of the signal being transmitted.

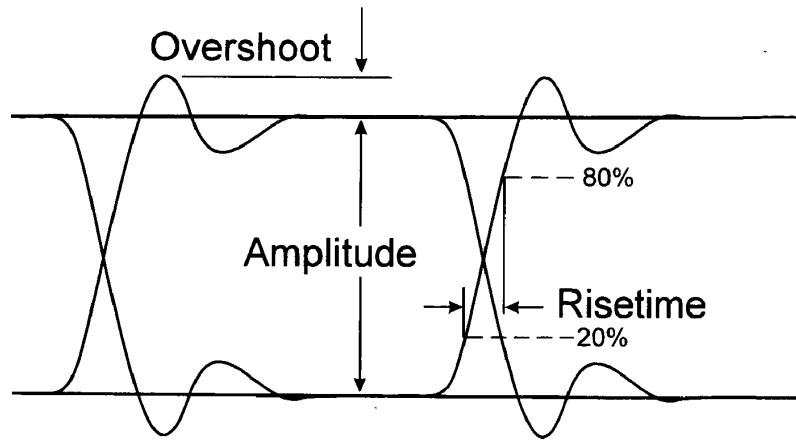

Figure 4 -- Waveform measurement dimensions

- 6.1.3 The peak-to-peak signal amplitude shall be 800 mV \pm 10%.
- 6.1.4 The dc offset, as defined by the mid-amplitude point of the signal, shall be nominally 0.0 V \pm 0.5 V.
- 6.1.5 The rise and fall times, determined between the 20% and 80% amplitude points shall be no greater than 135 ps and shall not differ by more than 50 ps.
- 6.1.6 Overshoot of the rising and falling edges of the waveform shall not exceed 10% of the amplitude.
- 6.1.7 Output amplitude excursions due to signals with a significant dc component occurring for a horizontal line (pathological signals), shall not exceed 50 mV above or below the average peak-to-peak signal envelope. (In effect, this specification defines a minimum output coupling time constant).
- 6.1.8 The jitter in the timing of the transitions of the data signal shall be measured in accordance with SMPTE RP 184. Measurement parameters are defined in SMPTE RP 184 and shall have the values shown in table 1 for compliance with this standard.
- 6.1.9 The receiver of the serial interface signal shall present an impedance of 75 ohms with a return loss of at least 15 dB over a frequency range of 5 MHz to $\frac{1}{2}$ the clock frequency of the signal being transmitted and at least 10 dB over a frequency range from $\frac{1}{2}$ the clock frequency up to the clock frequency of the signal being transmitted.
- 6.1.10 Receivers operating with input cable losses in the range of up to 20 dB at one-half the clock frequency are typical; however, receivers designed to work with greater or lesser signal attenuation are acceptable.
- 6.1.11 When connected to a line driver operating at the lower limit of voltage permitted by § 6.1.3, the receiver must sense correctly the binary data in the presence of the superimposed interfering signal at the following levels:

dc	\pm 2.5V
Below 5kHz	<2.5V p-p
5kHz to 27MHz	<100mV p-p
Above 27MHz	< 40mV p-p

Table 1-- Jitter specifications

f1	10 Hz	Timing jitter lower band edge
f3	100 kHz	Alignment jitter lower band edge
f4	> 1/10 the clock rate	Upper band edge
A1	2 UI	Timing jitter (Note 1)
A2	.3 UI	Alignment jitter (UI = unit interval) (Note 2)
Test signal	Color bar test signal	(Note 3)
n	≠10 (preferred)	Serial clock divided (Note 4)

NOTES

1 Designers are cautioned that parallel signals may contain jitter up to 2 ns p-p. Direct conversion of such signals from parallel to serial could result in excessive serial signal jitter.

2 This should be considered an absolute maximum requirement. An alignment jitter specification of 0.2 UI or better is strongly recommended.

3 Color bars are chosen as a non-stressing test signal for jitter measurements. Use of a stressing signal with long runs of zeros may give misleading results.

4 Use of a serial clock divider value of 10 may mask word correlated jitter components.

6.2 Connector and cable types

6.2.1 75 ohm BNC connectors that are usable at frequencies > 3.0 GHz - based on a return loss at 3.0 GHz that is greater than 10 dB - shall be used on equipment and installations that are compliant with this standard. The mechanical characteristics of the connectors shall conform to the 50-ohm BNC type defined by IEC 60169-8 -- Amendment 2 1997, Annex A.

The electrical characteristics of the connector and it's associated interface circuitry shall provide a resistive impedance of 75 ohms.

informative note - In IEC 60169-8, a 75 ohm BNC connector with the same mechanical center pin size as the 50-ohm BNC connector is normally achieved by changing the insulator material used in the connector.

6.2.2 75 ohm video coax cable that is specified for operation at frequencies > 3.0 GHz shall be used in installations that are compliant with this standard. It is necessary for the frequency response of the coaxial cable loss, in decibels, to be approximately proportional to $1/\sqrt{f}$ from 1 MHz to the clock frequency of the signal being transmitted to ensure correct operation of automatic cable equalizers over moderate to maximum cable lengths.

informative note - in many installations today, the 75 ohm video coax cable in use may be terminated with 50 ohm BNC connectors. Although this pairing is adequate for lower frequency bandwidths (such as standard NTSC composite video), this mismatch will result in signal degradation and reduced picture quality at digital video transmission rates. Such practice is not in compliance with this standard.

informative note - signal degradation may also be caused by the improper storage, handling and installation of the 75 ohm video coax cable.

6.2.3 Return loss of the correctly terminated transmission line shall be greater than 15 dB over a frequency range of 5 MHz to $\frac{1}{2}$ the clock frequency of the signal being transmitted and greater than 10 dB over the range $\frac{1}{2}$ the clock frequency to the clock frequency of the signal being transmitted.

Annex A (informative) Channel code

When scrambled NRZI channel coding is applied to certain video signals (informally called pathological signals), repeated long strings of 19 or 20 zeros may occur during the period of one horizontal television line. The methodology required to produce a stressing test signal is defined in RP 198 that will help in evaluating channel performance.

Annex B (Informative) Receiver Type

Receivers conforming to the specifications of § 6.1.11 should be labelled “Type A.” Receivers that may not conform to the specifications of § 6.1.11 should be labelled “Type B.”

Annex C (informative) Generator polynomial implementations-

Possible generator polynomial implementations are given in figures C.1 and C.2.

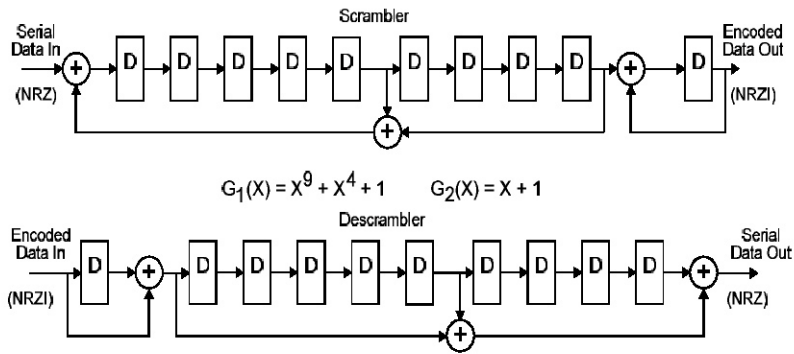

Figure C.1 -- Possible generator polynomial -- Method 1

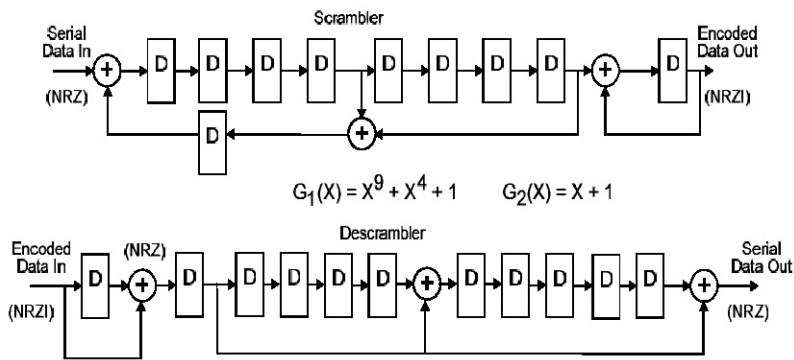

Figure C.2 -- Possible generator polynomial -- Method 2

Annex D (informative) Bibliography

SMPTE 352M-2002 for Television (Dynamic) - Video Payload Identification for Digital Interfaces

SMPTE 12M-1999 Television, Audio and Film – Time and Control Code

SMPTE 299M-2005 for Television - 24-Bit Digital Audio Format for SMPTE 292M Bit-Serial Interface

SMPTE RP 188-1999 Transmission of Time Code and Control Code in the Ancillary Data Space of a Digital Television Data Stream

SMPTE 291M-1998 Television – Ancillary Data Packet and Space Formatting

SMPTE 274M-2005 Television – 1920 x 1080 Image Sample Structure, Digital Representation and Digital Timing Reference Sequences for Multiple Picture Rates

SMPTE 296M-2001 Television – 1280 x 720 Progressive Image Sample Structure – Analog and Digital Representation and Analog Interface

SMPTE 372M-2002 Television – Dual Link 292M Interface for 1920 x 1080 Picture Raster

SMPTE 292M-1998, Television – Bit-Serial Digital Interface For High-Definition Television Systems

SMPTE RP 168-2002 Definition of Vertical Interval Switching Point for Synchronous Video Switching

SMPTE RP 198-1998 Bit-Serial Digital Checkfield for Use in High Definition Interfaces

Annex E (informative) Document roadmap

Example applications

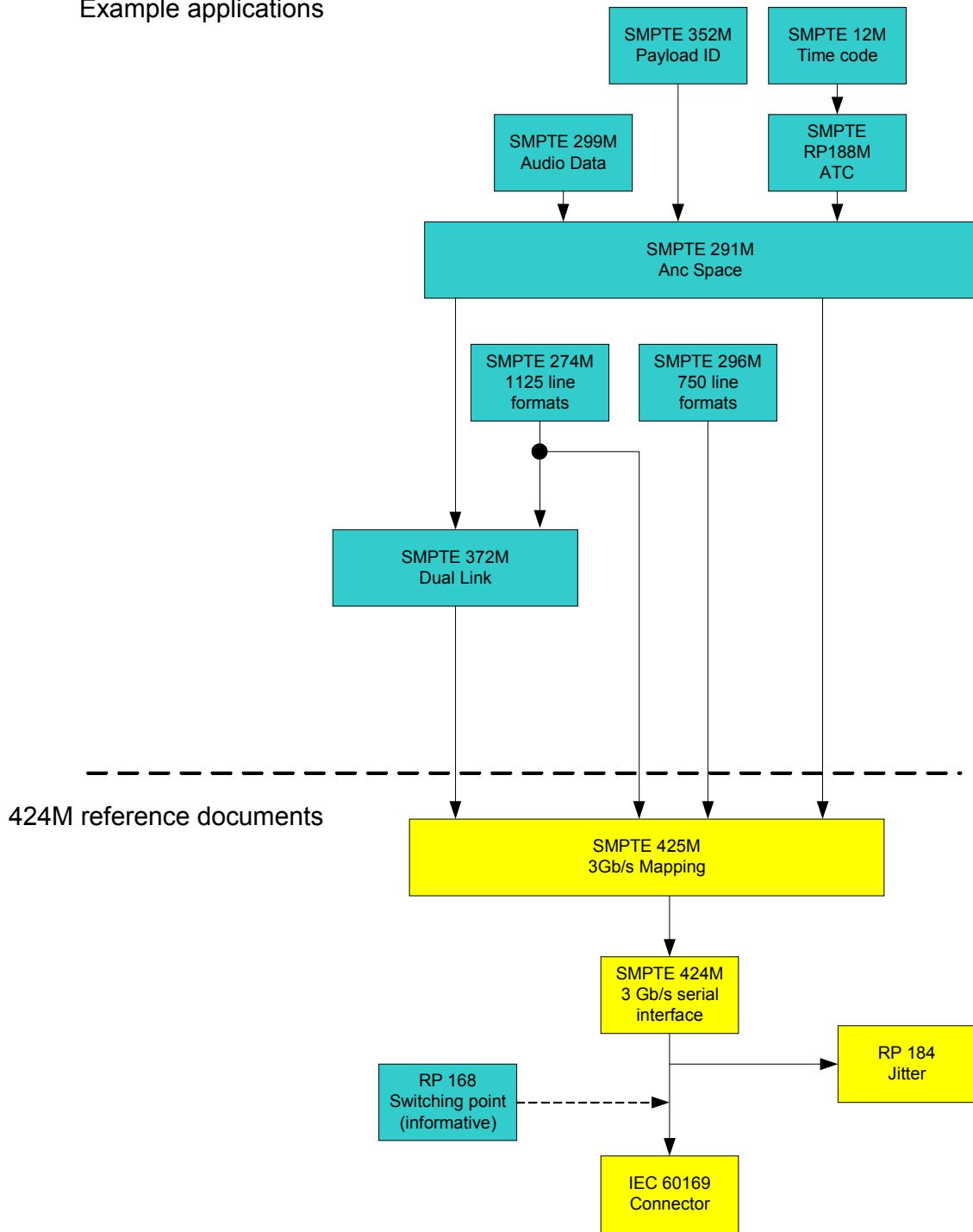

Copyright notice

Copyright 2005 THE SOCIETY OF MOTION PICTURE AND TELEVISION ENGINEERS

595 W. Hartsdale Ave.
White Plains, NY 10607
+1 914 761 1100
Fax +1 914 xxx xxxx
E-mail eng@smpte.org
Web www.smpte.org