

# TI 918L-800-25

## Integrated Gate-Commutated Thyristor

### Properties

- Full reverse voltage
- Low on-state losses
- Snubberless
- Suitable for inverters, drives and traction applications
- High reliability

### Key Parameters

$V_{DRM}, V_{RRM}$	=	2 500	V
$I_{TGQM}$	=	800	A
$I_{TAVm}$	=	630	A
$I_{TSM}$	=	10 000	A
$V_{TO}$	=	1.495	V
$r_T$	=	1.37	mΩ

### Types

	$V_{DRM}, V_{RRM}$
TI 918L-800-30	3 000 V
TI 918L-800-25	2 500 V
TI 918L-800-20	2 000 V

### Mechanical Data (see Fig. 6)

$F_m$	Mounting force	10 ± 2 kN
$m$	Weight	1,2 kg
$D_s$	Surface creepage distance	25 mm
$D_a$	Air strike distance	12 mm
$D_p$	Pole-piece diameter	47 mm
$l$	Length	285,6 mm
$h$	Height	56,5 mm
$w$	Width	112 mm



Fig. 1 Case

## Polovodice, a.s.

Novodvorska 1768/138a, 142 21 Praha 4, Czech Republic

tel.: +420 261 306 357 fax: +420 261 306 307, <http://www.polovodice.cz>

<b>Maximum Ratings</b>			<b>Maximum Limits</b>	<b>Unit</b>
$V_{DRM}$ $V_{RRM}$	<b>Repetitive peak off-state and peak reverse voltage</b> $T_j = -40 \div 115 \text{ }^\circ\text{C}$ , <i>Gate unit energized</i>	TI 918L-800-30 TI 918L-800-25 TI 918L-800-20	3 000 2 500 2 000	V
$V_{Dclink}$	<b>Permanent DC voltage for <math>\lambda = 100</math> FIT failure rate</b> <i>Gate unit energized</i>	TI 918L-800-30 TI 918L-800-25 TI 918L-800-20	1 800 1 500 1 200	V
$I_{TRMS}$	<b>RMS on-state current</b> $T_c = 70 \text{ }^\circ\text{C}$ , <i>half sine waveform, <math>f = 50 \text{ Hz}</math></i>		990	A
$I_{TAVm}$	<b>Average on-state current</b> $T_c = 70 \text{ }^\circ\text{C}$ , <i>half sine waveform, <math>f = 50 \text{ Hz}</math></i>		630	A
$I_{TSM}$	<b>Peak non-repetitive surge</b> <i>half sine pulse, <math>t_p = 10 \text{ ms}</math>, <math>V_R = 0 \text{ V}</math></i>		10 000	A
$\int I^2 dt$	<b>Limiting load integral</b> <i>half sine pulse, <math>t_p = 10 \text{ ms}</math>, <math>V_R = 0 \text{ V}</math></i>		500 000	A <sup>2</sup> s
$T_{jmin} - T_{jmax}$	<b>Junction operating temperature range</b>		-40 $\div$ 115	$^\circ\text{C}$
$T_{stgmin} - T_{stgmax}$	<b>Storage temperature range</b>		-40 $\div$ 80	$^\circ\text{C}$

Unless otherwise specified  $T_j = 115 \text{ }^\circ\text{C}$

Characteristics		Value			Unit
		min.	typ.	max.	
$V_{TM}$	Maximum peak on-state voltage $I_{TM} = 800 \text{ A}$ , CS - ON			2.65	V
$V_{T0}$	Threshold voltage			1.495	V
$r_T$	Slope resistance $I_{T1} = 333 \text{ A}$ , $I_{T2} = 1000 \text{ A}$			1.37	m $\Omega$
$I_{DM}$	Peak off-state current $V_D = V_{DRM}$ , Gate unit energized			150	mA
$I_{RM}$	Peak reverse current $V_R = V_{RRM}$ , Gate unit energized			150	mA

Unless otherwise specified  $T_j = 115 \text{ }^\circ\text{C}$

### Turn-on switching

Maximum rated values		Value	Unit
$(di_T/dt)_{cr}$	Critical rate of rise of on-state current	800	A/ $\mu\text{s}$
Conditions: $T_j = 90 \text{ }^\circ\text{C}$ , $I_T = 800 \text{ A}$ , $f = 0 \div 1000 \text{ Hz}$			
Characteristic values		Value	Unit
$I_{Tm}$	Peak on-state current	800	A
$t_{don}$	Turn-on delay time	$\leq 2.5$	$\mu\text{s}$
$t_r$	Rise on-time	$\leq 0.7$	$\mu\text{s}$
$E_{on}$	Turn-on energy per pulse	$\leq 0.2$	J
Conditions: $T_j = 95 \text{ }^\circ\text{C}$ , $L_{CL} = 0.2 \mu\text{H}$ , $L_i = 2 \mu\text{H}$ , $R_s = 12 \Omega$ , $V_{LC} = 0.6 V_{DRM}$ . (Fig. 8)			

### Turn-off switching

Maximum rated values		Value	Unit
$I_{TGQM}$	Max. controllable turn-off current	800	A
$t_{doff}$	Turn-off delay time	$\leq 3.5$	$\mu\text{s}$
$t_f$	Fall time	$\leq 0.6$	$\mu\text{s}$
$E_{off}$	Turn-off energy per pulse	$\leq 1.0$	J
Conditions: $T_j = 95 \text{ }^\circ\text{C}$ , $C_{CL} = 2 \mu\text{F}$ , $L_{CL} = 0.2 \mu\text{H}$ , $L_i = 2 \mu\text{H}$ , $R_s = 12 \Omega$ , $V_{LC} = 0.6 V_{DRM}$ . (Fig. 8)			

Thermal Parameters		Value	Unit
$R_{thjc}$	Thermal resistance junction to case double side cooling	24.0	K/kW
$R_{thch}$	Thermal resistance case to heatsink, double side cooling	6.0	K/kW

Polovodice, a.s., Novodvorska 1768/138a, 142 21 Praha 4, Czech Republic

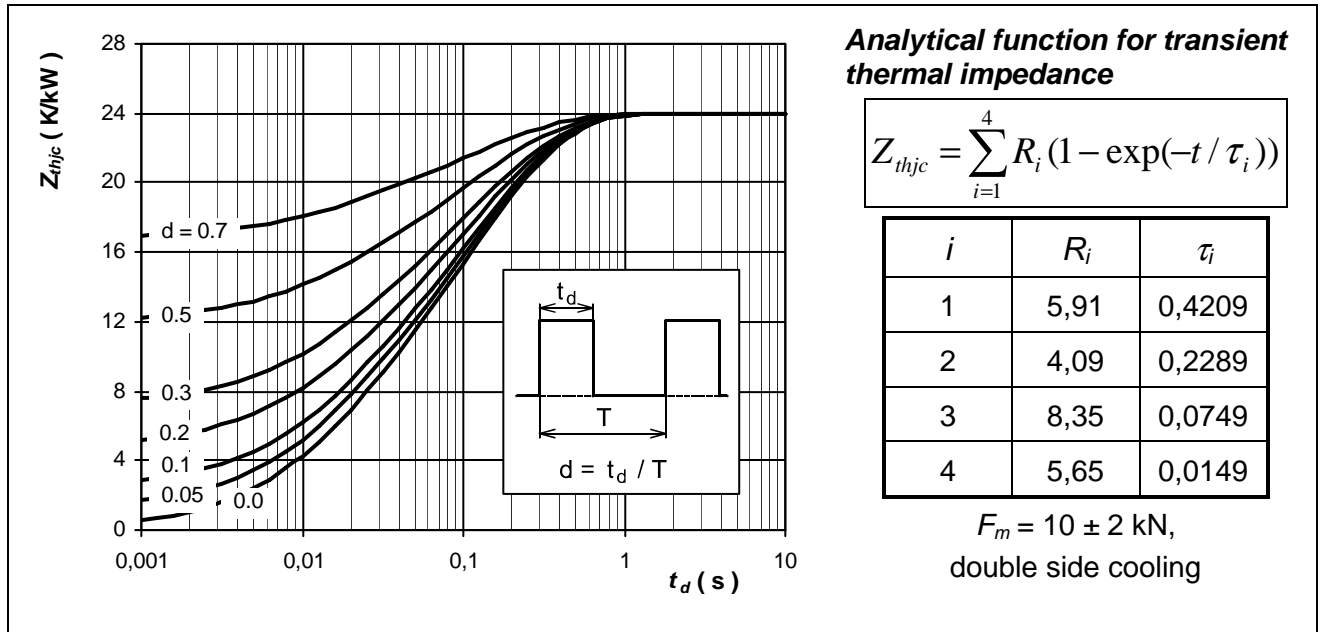

Fig.2 Transient thermal impedance junction to case

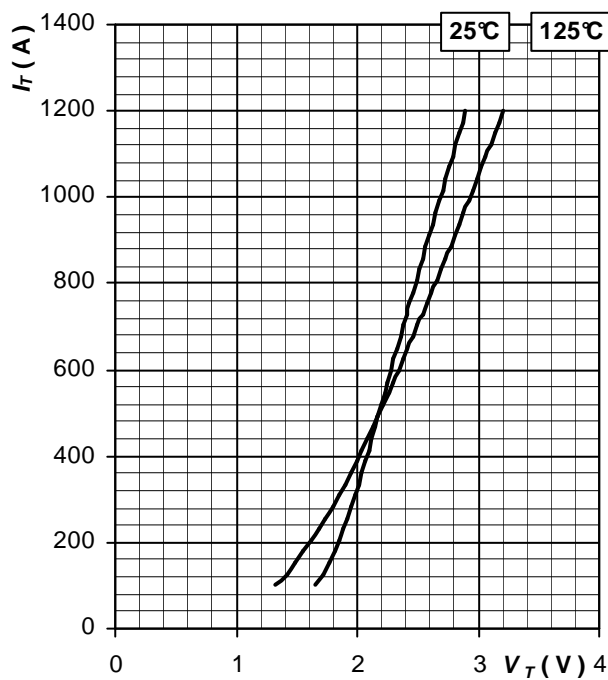

Fig.3 Maximum instantaneous on-state characteristics

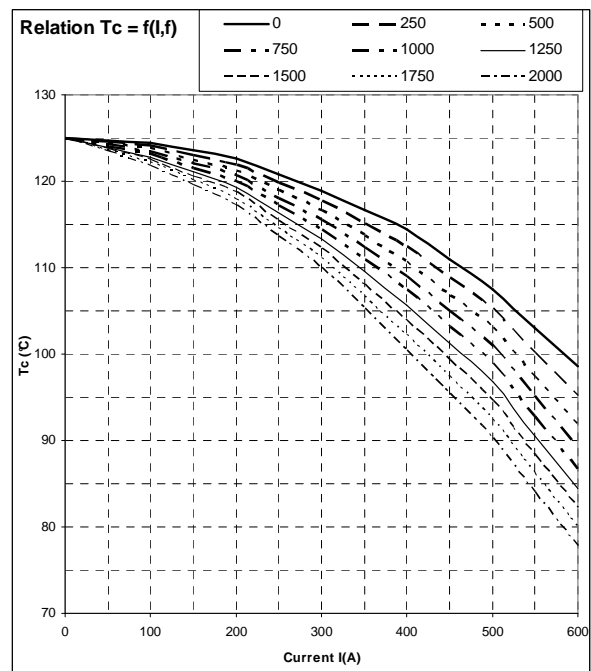

Fig.4 Maximum allowable case temperature  $T_c$  on rectangular turn-off current and frequency. Conditions:  $C_{CL} = 3 \mu F$ ,  $L_{CL} = 0.2 \mu H$ ,  $L_i = 3 \mu H$ ,  $R_s = 12 \Omega$ ,  $V_D = 1500V$

<b>Gate unit</b>		<b>Value</b>	<b>Unit</b>
$V_{GIN1}$	Input turn-off voltage of IGCT gate driver	- 20	V
$V_{GIN2}$	Input turn-on voltage of IGCT gate driver	2.5	V
$P_{max}$	Gate unit power consumption <sup>1)</sup>	80	W
$P_{on CS}$	Control Signal optical input power (B1)	> -20	dBm
$P_{off CS}$	Control Signal optical noise power (B1)	< -45	dBm
$P_{on SF}$	Status Feedback optical output power(B2)	> -20	dBm
$P_{off SF}$	Status Feedback optical noise power (B2)	< -50	dBm
$t_{onmin}$	Minimal on time	$5 \pm 20\%$	$\mu s$
$t_{offmin}$	Minimal off time	$6 \pm 20\%$	$\mu s$
$t_{GLITCH}$	Pulse width threshold	< 0.75	$\mu s$
$f_{max}$	Frequency	2 000	Hz
$t_{fd}$	Delay time of on gate current	2.0	$\mu s$
$t_{rd}$	Delay time of off gate current	2.0	$\mu s$
$D_{max}$	Maximum duty	100	%
$T_{wmin} - T_{wmax}$	Operating temperature range <sup>2)</sup> ( Fig. 5 )	-20 ÷ 70	°C
$T_{stgmin} - T_{stgmax}$	Storage temperature range	-40 ÷ 80	°C
<b>X1</b>	Gate part power connector (see Fig.6 )	BU0403 Hartman	-
<b>CS - B1</b>	LWL receiver for command signal	HFBR 2524 Agilent	-
<b>SF - B2</b>	LWL transmitter for status feedback	HFBR 1528 Agilent	-

Note 1: Powered with recommended supply unit SU 918A

Note 2: Recommended temperature:  $\leq 60^{\circ}C$

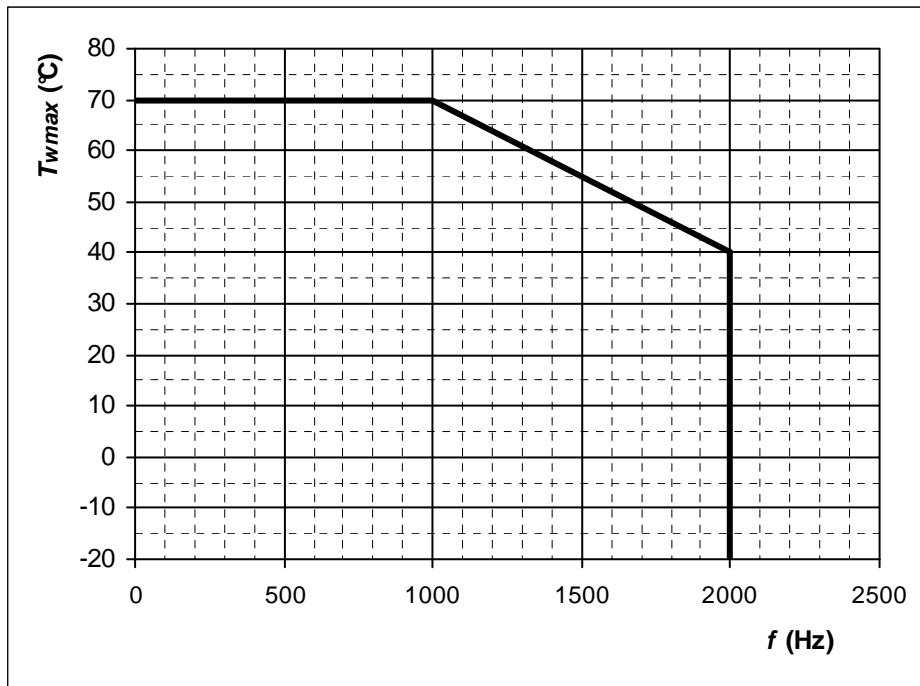

Fig. 5 Gate drive part operating temperature area

Supply unit (recommended type)		Value	Unit
V <sub>c</sub>	DC power supply – SU 918A - SU 918A-48	18 ÷ 36 36 ÷ 60	V
P	Power consumption (cut-off limit)	90	W
V <sub>out1</sub>	Output supply voltage	-20	V
T <sub>wmin</sub> - T <sub>wmax</sub>	Operating temperature range <sup>2)</sup>	-20 to +70	°C
V <sub>is/1min</sub>	Insulation strength	5.0	[kV]
m	Weight	1 220	g

Note 2: Recommended temperature: ≤ 60°C

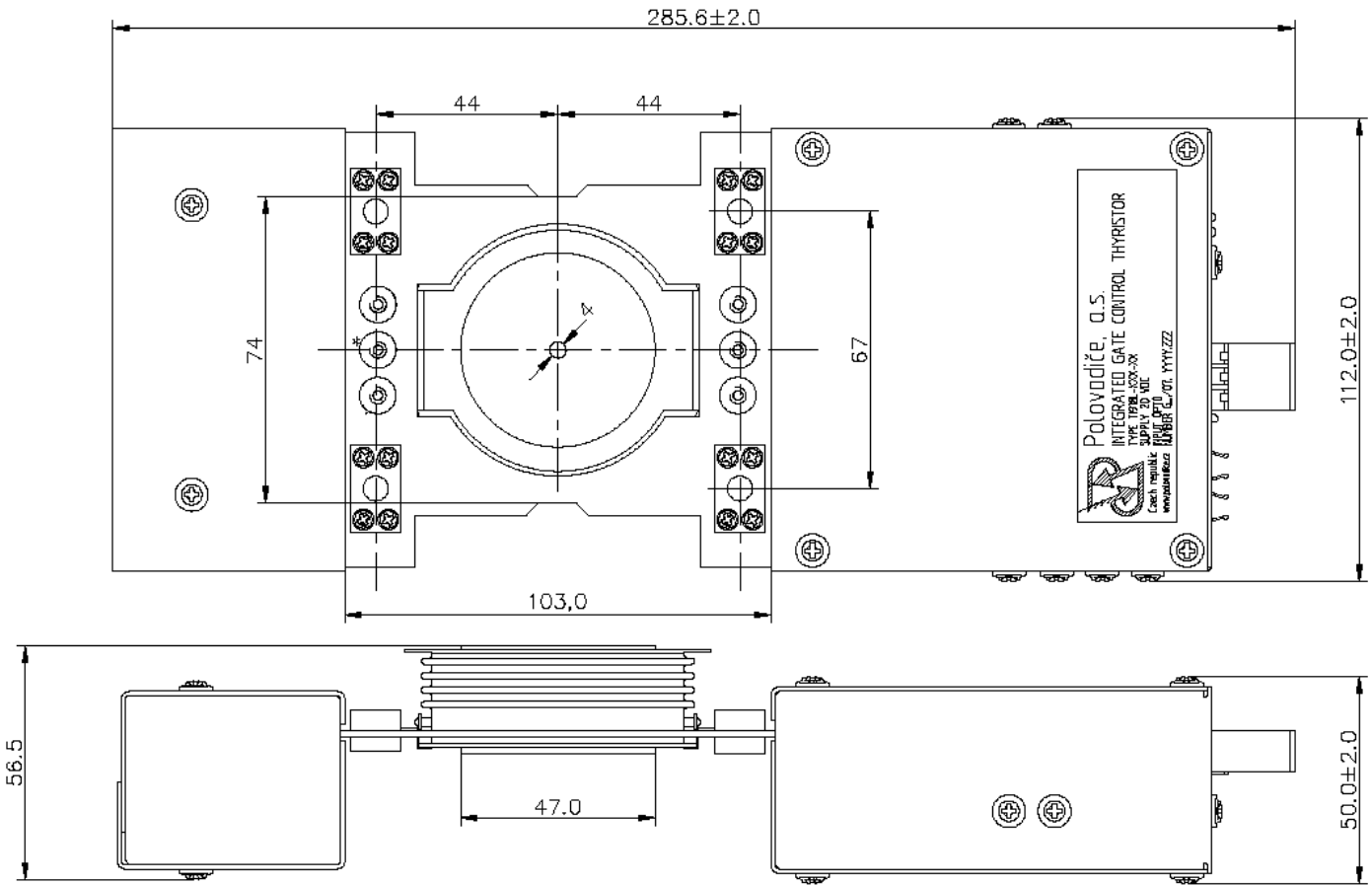

Fig. 6 Device gate part drawing

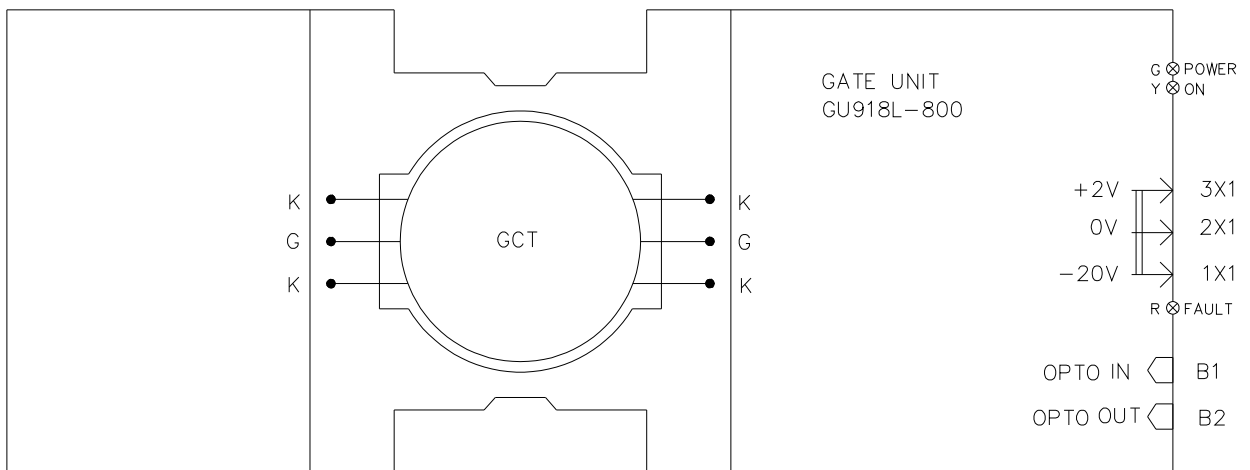

Fig. 7 Schema of input-output connection

Polovodice, a.s., Novodvorska 1768/138a, 142 21 Praha 4, Czech Republic

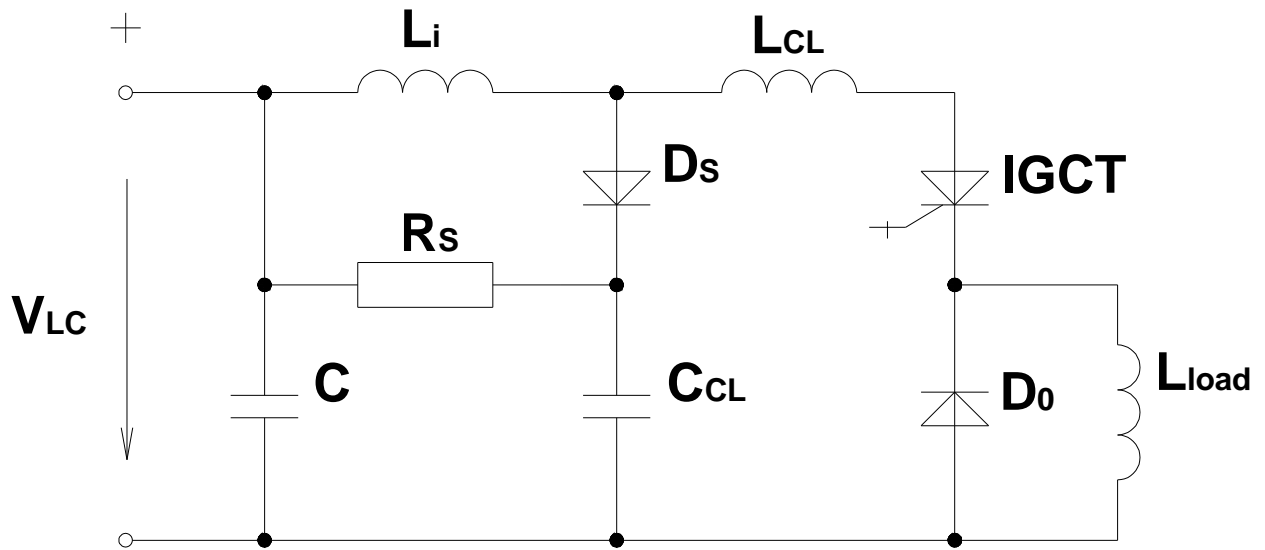

Fig.8 Test circuit.

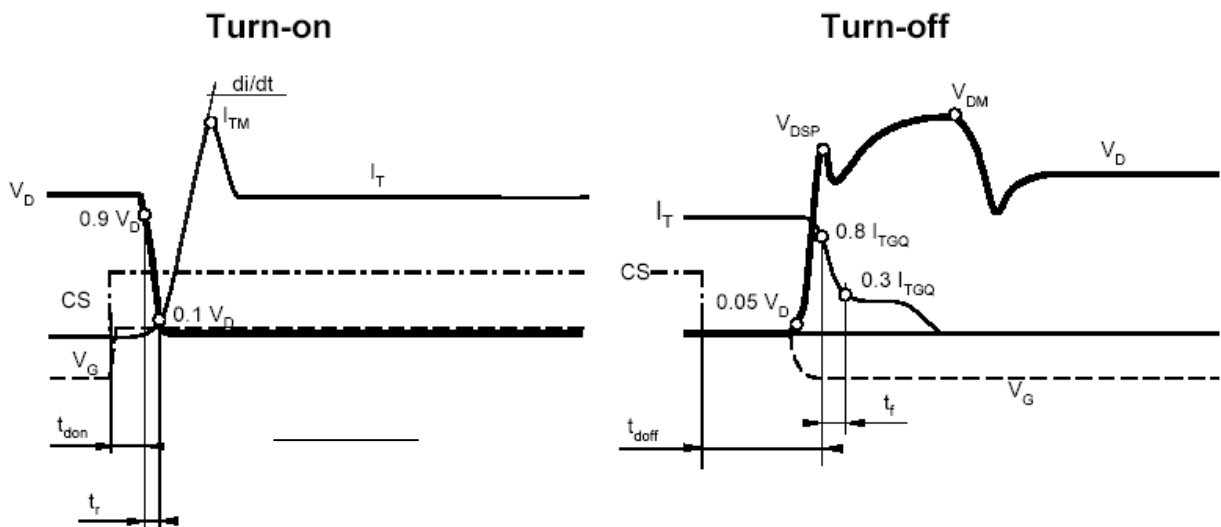

Fig. 9 Turn-on and turn-off waveform diagram