

BUMC  
Biosafety Manual  
Revised Document  
October 12, 2007

**BOSTON UNIVERSITY MEDICAL CENTER  
BIOSAFETY MANUAL**

The purpose of this manual is to define the biological safety policies and procedures pertaining to research operations at Boston University and Boston Medical Center. These policies and procedures are designed to safeguard personnel and the environment from biologically hazardous materials and to comply with federal, state, and local regulatory requirements. All BU and BMC Principal Investigators and laboratory workers must adhere to the biological safety policies and procedures in the conduct of their research and the management of their laboratories.

For information about specific biological safety programs for operations not covered in this manual, contact the Institutional Biosafety Committee office or the Biosafety Officer.

Chair, Institutional Biosafety Committee

Associate Vice President, Research Compliance

**BOSTON UNIVERSITY MEDICAL CENTER  
BIOSAFETY MANUAL**

**TABLE OF CONTENTS**

		<b>Page</b>
<b>Chapter 1</b>	Biological Safety Program: Purpose, Scope, and Responsibilities	4
<b>Chapter 2</b>	Approval of Research Projects	9
<b>Chapter 3</b>	List of Regulations and Guidelines	17
<b>Chapter 4</b>	Biosafety Principles	19
<b>Chapter 5</b>	Laboratory Biosafety Practices	26
<b>Chapter 6</b>	Laboratory Training	39
<b>Chapter 7</b>	Decontamination and Sterilization	43
<b>Chapter 8</b>	Biohazardous Spill Response	48
<b>Chapter 9</b>	Biohazardous and Medical Waste Disposal	54
<b>Chapter 10</b>	CDC/USDA Select Agents	57
<b>Chapter 11</b>	Transportation of Biological Materials	73

<b>Appendix A</b>	IBC Application Forms	85
<b>Appendix B</b>	Importation and Exportation of Etiologic Agents	86
<b>Appendix C</b>	Laboratory Ventilation and Containment for Biosafety	89
<b>Appendix D</b>	Autoclave Quality Assurance Program	96
<b>Appendix E</b>	Biosafety Level 2 (BSL-2) Requirements	99
<b>Appendix F</b>	Biosafety Level 3 (BSL-3) Facility Standard Operating Procedure (SOP)	105
<b>Appendix G</b>	Biosafety Level 4 (BSL-4) Requirements	121
<b>Appendix H</b>	Guidelines for Work With Toxins of Biological Origin	128
<b>Appendix I</b>	Prion Research/Cruetzfeld-Jacob Disease (CJD) Guidelines	132
<b>Appendix J</b>	Summary of Requirements for Biosafety Levels	135
<b>Appendix K</b>	Summary of Requirements for Animal Biosafety Levels	137
<b>Appendix L</b>	Bloodborne Pathogen Standard	139
<b>Appendix M</b>	Working Safely with Animals	145
<b>Appendix N</b>	Procedures for Working in an Animal Biosafety Level 2 (BSL-2) Facility at BU	147
<b>Appendix O</b>	Policy for Verifying the Identity of Attenuated Pathogens	152
<b>Appendix P</b>	Boston Public Health Commission Requirements	153
<b>Appendix Q</b>	Medical Surveillance Program	154
<b>Appendix R</b>	Laboratory and Equipment Decontamination Procedures	155
<b>Appendix S</b>	Laboratory Door Signage	163

<b>Appendix T</b>	Boston University and Boston Medical Center Research Compliance Policy on Disease Surveillance and Reporting for High-Risk Agents	164
<b>Appendix U</b>	Institutional Biosafety Committee Oversight Program	171
<b>Appendix V</b>	Criteria for Development of Standard Operating Procedures (SOP)	174

## Chapter 1

### **Biological Safety Program: Purpose, Scope, and Responsibilities**

#### **Purpose**

The purpose of this Biosafety Manual (BSM) is to define policies and procedures pertaining to use of biological materials in research at Boston University (BU) and Boston Medical Center (BMC). These policies and procedures are designed to safeguard personnel and the environment from biologically hazardous materials without unduly limiting academic research. This manual also offers guidelines to comply with federal and state regulatory requirements.

The work practices, procedures, and policies specified in this manual are based on current regulatory requirements and accepted best biosafety practices. Implementation of these measures will reduce the likelihood that an incident involving a biological agent will occur and will fulfill regulatory biosafety expectations. Laboratory microbiological work usually involves potential exposure to biological hazards, as well as to chemical and radiological hazards. Consequently, this manual should be used in conjunction with the BU and BMC Lab Safety Manuals, Chemical Hygiene Plans and Radiation Protection Program Manual, and Radiation Safety Guide, respectively.

For information about specific biological safety programs for operations not covered in this manual, contact the Institutional Biosafety Committee (IBC) office or the Biosafety Officer (BSO).

#### **Scope**

This manual applies to all BU and BMC research activities involving biological agents. All faculty, staff, students, and visitors who work on BU- or BMC-sponsored projects or at BU or BMC facilities are included in the scope of this manual.

Biological agents include all infectious microorganisms (bacteria, fungi, parasites, prions, rickettsias, viruses, etc.) that can cause disease in humans or pose significant environmental or agricultural impact, as well as the toxins derived from such organisms. Additionally, recombinant DNA; human or non-human primate tissues, fluids, cells, or cell cultures; transgenic plants or animals; and any work with animals and their tissues, which are known to be reservoirs of zoonotic diseases, are wholly or partly covered by the procedures and policies in this manual.

**Note:** *In this document, the term “Institution” is used to refer to the combined BU and BMC entities.*

#### **Biological Safety Program Goals**

The goals of the Biological Safety Program, referenced in this manual as the Biosafety Program, are to protect laboratory workers, the public, and the environment from potentially hazardous biological agents. The IBC advocates the use of biosafety precautions that effectively reduce or eliminate the risk of exposure to potentially hazardous agents used in research. In developing its guidelines, the IBC is ensuring that all policies and procedures are in accordance with both the regulatory frameworks governing the use of biological materials and the best practices adopted nationally.

Chapter 3 contains a listing and summary of the regulations and guidelines that govern the use of biological materials in research.

### **Roles and Responsibilities**

Success of the Biosafety Program, like any other safety program, requires a team effort involving the IBC, Principal Investigators, laboratory workers, the Occupational Health Program, and the Office of Environmental Health and Safety (OEHS). **Principal Investigators are responsible for the health and safety of personnel who work under their supervision and occupy their laboratory space.** BU and BMC administration, the IBC, and OEHS endorse this manual and encourage active participation in maintaining high standards at BU and BMC.

#### **• Associate Vice President, Research Compliance (AVP-RC)**

The AVP-RC has overall responsibility for:

- Oversight for the control of hazards in the research laboratories and for ensuring that comprehensive, enterprisewide programs are in place for the safe handling of all hazardous (e.g., biological, chemical, radiological, etc.) materials.
- All non-financial research compliance at BU and BMC.
- Direct functional responsibility for the IBC, Biosafety Program, OEHS, the Charles River Institutional Review Board (IRB), laboratory safety committees, biosafety programs, laboratory animal use and care programs (both Institutional Animal Care and Use Committees (IACUC) and the animal care programs), responsible conduct of research, and other research-related oversight committees.
- Acts as the Responsible Official (RO) for the City of Boston's Public Health Commission laboratory regulations.
- Develops and ensures communication between IBC, IRB, IACUC, sponsored research offices, and regulatory agencies (e.g., City of Boston, CDC).
- In consultation with provosts and deans at both the medical campus and the Charles River campus, as well the BMC leadership, appoints various committee members. The IBC, the Biosafety Program Director, the Occupational Health Program, and OEHS have been charged with planning and

implementing the Biosafety Program, the purpose of which is to ensure the health and safety of all personnel working with biohazardous or infectious agents and recombinant DNA.

• ***Institutional Biosafety Committee***

The Institutional Biosafety Committee (IBC) is responsible for overall oversight of the Biosafety Program at BU and BMC (See Appendix U for IBC oversight Program). The IBC carries out these functions pursuant to requirements set forth by the National Institutes of Health (NIH), the Centers for Disease Control and Prevention (CDC), Occupational Safety and Health Administration (OSHA), the City of Boston Public Health Commission (BPHC), the Massachusetts Department of Public Health (DPH), and Boston University.

The IBC's responsibilities include:

- Overall oversight of the Institutional Biosafety Program at BU and BMC, including development of new, and review of existing, policies and procedures designed to enhance the biological safety programs. Reviews and approves training programs and establishes qualifications for individuals working with biological materials.
- Reviews and approves gene transfer clinical trials.
- Coordinates the biological safety requirements with other campus-wide committees (e.g., IACUC) or programs (e.g., Occupational Health).
- Reviews and approves new research proposals involving rDNA and biohazardous material in accordance with guidelines established by the BPHC, DPH, OSHA, U.S. Department of Agriculture (USDA), CDC, NIH, BU and BMC, as well as maintains project approval and reviews amendments.
- Sets required containment levels for research projects. Generally, biosafety levels (BSL) established by the CDC and NIH will be used as the level of containment; however, the IBC has the authority to increase or decrease the level of containment according to the project's specific circumstances. However, the IBC also has the authority to upgrade laboratory containment levels if the protocol review identifies specific hazards associated with the proposed operations.
- Approves design specifications and criteria for containment facilities developed by the Biosafety Officer and conducts the final review and acceptance of BSL-3 and BSL-4 laboratories. Develops comprehensive inspection programs, as well as receives and reviews the findings of such inspections. Investigates violations of biosafety procedures or policies and significant accidents or illnesses involving biological agents.
- If appropriate, recommends disciplinary action to the proper BU/BMC officials.
  - Reviews and approves annual reports sent to: Boston Public Health Commission, under the rDNA ordinance
  - NIH, concerning rDNA exposures incidents
  - NIH's Office of Biotechnology Activities, an IBC update
- Other activities as delegated by the Provost or the AVP-RC.

• ***Biosafety Officer/ Research Safety Program Director [Note: this is the new title of the program]***

The Biosafety Officer (BSO), who also acts as the Research Safety Program Director, is responsible for providing guidance on the safe handling of biological agents and overall management of the Biosafety Program. The BSO is an ex-officio member of the IBC.

The BSO's specific responsibilities include, but are not necessarily limited to, the following:

- Provides technical advice to the IBC, and researchers on laboratory containment, security, and safety procedures. Oversees periodic and unscheduled inspections to ensure that laboratory standards are rigorously maintained.
- Develops emergency plans for handling spills and personnel contamination.
- Develops and implements laboratory safety practices.
- Develops design specifications and criteria for containment facilities.
- Coordinates the preparation of IBC reports submitted to regulatory agencies.
- Acts as a liaison during regulatory inspections and works with the AVP-RC, IBC, and other institution officials to coordinate responses to any regulatory findings.
- Provides training programs as approved by the IBC.
- Acts as the Responsible Official (RO) for the Select Agent Program.

The BSO regularly reports on the Biosafety Program to the IBC. The BSO's report should include routine operational updates and any significant problems or violations of the regulatory mandates or IBC requirements on any research-related accidents or illnesses that have occurred.

• ***Office of Environmental Health and Safety***

The various programs within the Office of Environmental Health and Safety (OEHS) work closely with the BSO to ensure that operations for which OEHS has responsibility are conducted in accordance with the criteria and guidelines established by the BSO. These include:

- Disposal of medical waste.
- Selection of appropriate protective clothing for individuals working with hazardous, including biohazardous, materials.
- Development and implementation of emergency response and preparedness.
- Monitoring work areas, including for the presence of allergens.

[  
• ***Principal Investigators***

Principal Investigators (PIs) are responsible for the health and safety of all personnel and compliance with all applicable regulations and the criteria established in this manual in their laboratories. The PI:



- Ensures that specific laboratory hazards are effectively communicated to laboratory personnel; personnel have received appropriate training and are competent to perform procedures used in the laboratory; and controls are in place to minimize risks associated with these hazards.
- Develops laboratory-specific standard operating procedures (SOPs) that cover the hazards and activities (both routine activities and unusual events) relevant to the laboratory.
- Ensures that engineering controls are available, in good working order, and are used appropriately to minimize exposure to biohazardous agents.
- Ensures that appropriate personal protective equipment is available and used by laboratory personnel.
- Ensures that all laboratory personnel receive general biosafety training that is conducted as part of the Biosafety Program, as well as specific training on the hazards, procedures, and practices relevant to the laboratory in which they are working. All training must be documented and records maintained.
- Notifies the IBC and obtains prior IBC approval for work involving recombinant DNA and/or biohazardous material and conforms to all terms and conditions of IBC approval.
- Ensures that laboratory workers are provided immunizations and medical surveillance prior to, and in the event of, exposure to biohazardous agents as appropriate (based on current CDC and IBC recommendations). Immunizations are available at BMC's Occupational and Environmental Medicine, (617) 638-8400, and at CRC at BU's Occupational Health Center, (617) 353-6630, for employees.
- Notifies the BUMC/BMC Control Center at (617) 638-6666 or OEHS emergency telephone, (617) 353-7233 at the Charles River Campus, of any spills or incidents involving biological agents that result in exposure to laboratory personnel or the public, or release to the environment. ***The Control Center will notify the BSO.***
- Ensures that biological agents are disposed of according to regulations, as outlined in this manual.
- Ensures that biohazardous materials to be transported are packaged and shipped in accordance with regulations.
- Ensures that periodic inspections of the laboratory are conducted.

• ***Laboratory Workers***

Laboratory workers are the most important element in developing and maintaining a safe laboratory environment. Laboratory workers are responsible for their own health and safety, as well as that of their

coworkers. An incident caused by one laboratory worker can have a widespread effect on others. Laboratory workers are expected to:

- Follow procedures and practices established by BU or BMC, the IBC, and the laboratory.
- Use best biosafety laboratory practices to minimize exposures to biological agents and to avoid other incidents (such as personal injuries, chemical and radiation spills, laboratory fires, explosion, etc.).
- Attend biosafety and other laboratory safety training as required.
- Report spills, accidents, and unsafe laboratory conditions to the PI, OEHS, or other responsible parties.
- Utilize control measures, such as biological safety cabinets and personal protective equipment, to prevent exposure to biological agents and contamination of personnel and facilities.

## Chapter 2

### Approval of Research Projects

#### • Who Needs Approval

Principal Investigators (PIs) at BU and BMC planning to carry out research using recombinant DNA and/or biologically hazardous materials that pose a potential risk to the health of humans or animals, either directly through infection or indirectly through damage to the environment, should submit an “Application for Work with rDNA and/or Biohazards” to the IBC office for review and approval.

The “quick guide” provides additional information regarding how to get started at BU and BMC.

**Note:** *Because the Boston Public Health Commission (BPHC) requires registration of BSL-1 rDNA projects, studies designated Biosafety Level 1 (BSL-1) and considered "exempt" by the NIH must be reviewed and approved by the IBC.*

Researchers using any of the following should complete and submit an “Application for Work with rDNA and/or Biohazards” for review and approval:

- Recombinant DNA
- Infectious agents
- Toxins
- Human blood, body fluids, unfixed tissue, or human cell cultures
- Tissues, organ, or cell lines cultures of human or non-human primate origin
- Creating transgenic animals
- Human gene therapy
- Non-human primates (because of the potential to transmit herpes and other diseases)
- Sheep and any tissues derived from them (these tissues can transmit *Coxiella burnetii*, the causative agent of Q-fever)
- Transgenic plants
- Wild animals known to carry zoonotic diseases (e.g., bats, raccoons, etc.)

When working with potentially infectious agents *and* human subjects or experimental animals, IBC review is necessary *in addition* to review by the Institutional Animal Care and Use Committee (IACUC) or the

appropriate Institutional Review Board (IRB).

- PIs whose research will involve biohazardous materials, infectious agents, human tissue (e.g., blood, cells, fluids, etc.) or whose research comes under the governance of any of the following campus rules or governmental regulations, are required to complete an “Application for Work with rDNA and/or Biohazards” and obtain IBC approval prior to receiving such materials or commencing such research. PIs are also required, where applicable, to maintain a medical surveillance program for laboratory employees (see Appendix Q). Relevant campus and/or governmental regulations include the following:
  - *NIH Guidelines for Research Involving Recombinant DNA Molecules*
  - Boston Public Health Commission
  - OSHA Bloodborne Pathogens Standard
  - OSHA Tuberculosis Standard
  - Massachusetts Department of Public Health
  - The Centers for Disease Control and Prevention (CDC) Select Agent regulations
  - Massachusetts Department of Health and Human Resources’ Medical Waste Management Act
  - International, federal, and state transport regulations

**Note:** *If a Principal Investigator is performing this type of work without IBC approval, he or she is out of compliance with current NIH and local regulations and has placed the institution in that position as well.*

#### • **New Applications**

A new “Application for Work with Recombinant DNA and/or Biohazards” must be submitted and reviewed by the IBC for any research using rDNA and/or biologically hazardous materials. PIs seeking IBC approval for the first time also need to submit a curriculum vitae (CV) with their application. One application for both rDNA and biohazardous work may be downloaded from the IBC website, <http://www.bumc.bu.edu/ibc>.

IBC approval of recombinant DNA and biohazardous research projects is effective for three years. PIs must complete a renewal form annually to continue work for up to three years after the initial approval. After three years, the application must be resubmitted and reviewed by the committee.

#### • **Renewals**

A renewal notice is sent to the PI listed on the original approval the first and second year after initial approval of a protocol. The PI is asked to list all proposed deviations from the protocol as initially approved (or since

the last renewal notice); changes in laboratory location; changes in laboratory staff working on the project; and any project titles to be added.

If there are significant deviations from the protocol, especially deviations that affect the containment level (i.e., new study organisms, a new host-vector-donor system, or any other modifications that may affect the containment level), the IBC may ask the PI to seek an additional approval to cover the additional experiments.

When a project is renewed, all new lab staff must submit a Medical Surveillance form online and complete lab safety training. For changes in PI, the new PI must attach his or her CV (two-page NIH format) to the “IBC Notice of Project Renewal.”

#### • **Amendments**

Amendments must be submitted in electronic or hard copy form for changes within an approved project. All changes should be detailed in the “Protocol Amendment” form, which the IBC must review and approve. Title additions (expedited review) approval may be applied to several different granting agencies, but all grant titles must be registered with the IBC. Lab space additions (expedited review) approval applies only to work performed in registered lab space. For non-PI personnel changes (expedited review), individuals must be trained in lab techniques and have complied with necessary trainings or approval procedures, such as medical surveillance and lab safety training.

If technical changes (full committee review) are extensive, the IBC may require the PI submit a completely new application. A change in PI also requires full committee review. The new PI must attach his or her CV (two-page NIH format) to the amendment.

#### • **Biohazardous and Potentially Infectious Materials**

##### *Categories*

Biohazards are infectious agents or biologically derived infectious materials that present a risk or potential risk to the health of humans or animals, either directly through infection or indirectly through damage to the environment. Infectious agents have the ability to replicate and give rise to potentially large populations in nature when small numbers are released from a controlled situation.

The following is a listing of the potentially hazardous biological materials and agents. PIs should follow the instructions in the Biosafety Application Package carefully to ensure that all appropriate sections of the application are completed. If a PI intends to use biological agents that are not listed in this section, he or she should contact the IBC or BSO for advice regarding proper completion of the “Application for Work with Recombinant DNA and/or Biohazards.”

- Human, animal, and plant pathogens

- Viruses, including oncogenic and defective viruses
- *Rickettsiae*
- Chlamydiae
- Bacteria, including those with drug-resistant plasmids
- Fungi
- Parasites
- Undefined or other infectious agents, such as prions
- All human blood, blood products, tissues, and certain body fluids
- Cultured cells (all human or certain animal, including non-human primates) and the potentially infectious agents these cells may contain
- Allergens
- Toxins (bacterial, fungal, plant, etc.)
- Certain recombinant nucleic acid products
- Clinical and diagnostic specimens
- Infected animals and animal tissues
- Non-human primates and any tissues derived from them (can transmit Herpes B virus)
- Sheep and any tissues derived from them (can transmit *Coxiella burnetii*, the causative agent of Q-fever)

Note: The IBC has developed Policy for Verifying the Identity of Attenuated Pathogens (Appendix O) that must be followed by all researchers.

### ***Recombinant DNA (rDNA) Materials***

#### **• Generation or Use of rDNA**

The NIH's *Guidelines for Research Involving Recombinant DNA Molecules* is the definitive regulatory reference for recombinant DNA (rDNA) research in the United States. There may be experiments, not covered by the guidelines, that would require review and approval by outside agencies before initiation. If the experimental protocol is not covered by the NIH's guidelines, contact the BSO at (617) 638-4263 to determine further review requirements.

Note: rDNA work with BSL-4 classification is not permitted in Boston.

#### **• Human Gene Therapy**

All protocols involving human gene therapy must be submitted to the NIH Office of Biotechnology Activities to undergo initial review by the Recombinant Advisory Committee (RAC).

After RAC review, the protocol must be approved by the IBC and IRB. For more details about IBC approval of human gene therapy protocols, call (617) 638-4276. For information about IRB submissions, call (617) 638-7207 (BUMC) or (617) 357-4365 (CRC).

### ***Use of Animals***

The use of animals in research requires compliance with the “Animal Welfare Act,” issued by the USDA’s Animal and Plant Health Inspection Service (APHIS); the “Public Health Service Policy on Humane Care and Use of Laboratory Animals,” administered by NIH’s Office of Laboratory Animal Welfare (OLAW); and all applicable state or local regulations covering the care and use of animals. All protocols involving the use of animals must be reviewed and approved by the IACUC before their implementation.

All PIs planning to use rDNA and/or biohazardous materials must first receive IBC approval.

#### **• Transgenic Animals**

PIs who create transgenic animals must complete an IBC application and submit it to the IBC for approval prior to initiation of experimentation. In addition, the IACUC must approve the protocol. The IACUC can be reached at (617) 638-4263 (BUMC) or (617) 358-3867 (CRC).

#### **• Tissue Culture/Cell Lines**

##### **Risk Group 1/Biosafety Level 1 (BSL-1)**

The following are considered Risk Group 1 cell lines and are handled at BSL-1:

- They are non-primate or are of normal, non-human primate origin
- They do not harbor a primate virus
- They are not contaminated with bacteria, mycoplasma, or fungi
- They are well established

**Note:** *All human and non-human primate cell lines must be used at BSL-2 as they may harbor previously undefined pathogens.*

##### **Risk Group 2/Biosafety Level 2 (BSL-2)**

When cell cultures are known to contain an etiologic agent or an oncogenic virus, the cell line can be classified at the same level as that recommended for the agent or virus. The CDC has recommended that all cell lines of human origin be handled at BSL-2.

The following are identified as Risk Group 2 and must be handled at BSL-2:

- Primate cell lines derived from lymphoid or tumor tissue
- All cell lines exposed to or transformed by a primate oncogenic virus
- All clinical material (e.g., samples of human tissues and fluids obtained after surgical resection or autopsy for use in organ culture or establishment of primary cell cultures)
- All primate tissue
- All cell lines new to the laboratory (until proven to be free of all adventitious agents)

- All virus and mycoplasma-containing primate cell lines

### **Risk Group 3/Biosafety Level 3 (BSL-3)**

When cell cultures are known to contain any BSL-3 listed in biological agents in BMBL (Fifth edition), the cell line can be classified at the same level as that recommended for the agent or virus.

The following are examples of biological materials identified as Risk Group 3 and must be handled at BSL-3:

- High titer HIV work
- St. Louis encephalitis virus
- Venezuelan equine encephalomyelitis virus
- M. tuberculosis
- Concentrated Lentivirus or Lentiviral vectors with high likelihood of aerosol formation.
- *Francisella tularensis*

See Appendix-F: BSL-3 Facility Standard Operating Procedures.

### **Risk Group 4/Biosafety Level 4(BSL-4)**

When cell cultures are known to contain any BSL-4 listed in biological agents in BMBL (Fifth edition), the cell line can be classified at the same level as that recommended for the agent or virus.

The following are examples of biological materials identified as Risk Group 4 and must be handled at BSL-4:

- Marburg
- Ebola
- Junin
- Machupo
- Guanaito

See Appendix-G: BSL-4 Requirements.

Note: Appendix J provides a summary of Biosafety Level requirements for each risk group.

### ***Tuberculosis***

Since 1985, the incidence of tuberculosis in the United States has been increasing steadily, reversing a 30-year downward trend. Recently, drug-resistant strains of *Mycobacterium tuberculosis* have become a serious concern. Outbreaks of tuberculosis, including drug-resistant strains, have occurred in health-care environments.



In 2005, the CDC published *Guidelines for Preventing the Transmission of Mycobacterium tuberculosis in Health-care Settings*. MMWR 2005; 54 (No. rr-17, 1-141). (Errata published September 25, 2006.) The guidelines contain specific information on ventilation requirements, respiratory protection, medical surveillance, and training for those personnel who are considered at-risk for exposure to tuberculosis. For more information, contact the BSO.

PIs intending to work with *Mycobacterium tuberculosis* in the laboratory must obtain written approval from the IBC via the IBC application process before beginning work. Propagation and manipulation of *Mycobacterium tuberculosis* cultures must be performed at Biosafety Level 3 (BSL-3).

### ***Vaccinia Virus***

PIs wishing to use vaccinia virus must obtain written approval from the IBC via the application process. BSL-2 practices and procedures must be followed. All employees who directly handle cultures or animals contaminated or infected with vaccinia virus, recombinant or defective vaccinia viruses, or other orthopox viruses that infect humans should be offered the smallpox vaccine.

### ***Tularemia Bacteria***

Tularemia, or rabbit fever, is a bacterial disease associated with both animals and humans. According to the CDC, “Tularemia is a potentially serious illness that occurs naturally in the United States. It is caused by the bacterium *Francisella tularensis* found in animals (especially rodents, rabbits, and hares).”

The use of tularemia-causing bacteria at BU/BMC is strictly regulated by the IBC and must be conducted in designated BSL-3 facilities.

### ***Herpes B virus***

*Cercopithecine herpesvirus 1* (*Herpesvirus simiae* or B-virus) is an endemic infection in Old World primates of the genus *Macaca*, which is the species most commonly used in biomedical research. It is assumed that all existing animals in the United States are carriers.

Although herpes B virus is relatively benign in the macaque monkey, it can cause rapidly ascending encephalomyelitis in humans with a fatality rate of approximately 80%. The most common route of transmission of the virus is through bites, scratches, splashes, or cuts.

All research involving Old World primates must be approved by both the IACUC and the IBC. Additional occupational health screening and personal protective equipment (PPE) requirements are described in this manual.

### **• Human Tissue and Cell Culture**

### ***Working with Human Tissues and Cells***

All unfixed human tissue and cells are to be assumed to be infectious (the concept of “universal precautions”) and must be handled using BSL-2 practices and procedures. Persons who are exposed to these materials in the laboratory are considered to have potential exposure to bloodborne pathogens, such as human immunodeficiency virus (HIV) and hepatitis B virus (HBV), and must be included in the Bloodborne Pathogens program. These persons must be offered the hepatitis B vaccination (they do not have to accept) and receive annual bloodborne pathogens training.

### ***Cell Culture***

Human or animal pathogens may be associated with cell or organ cultures. Cell cultures known (or suspected) to contain an etiologic agent or an oncogenic virus are classified at the same biosafety level as that recommended for the agent.

The following cell cultures and tissues require BSL-2 or higher containment and procedures:

- All cultured cells derived from human sources, including immortalized and “well established” cell lines.
- All cultured cells derived from non-human primates, primate lymphoid, or tumor tissue.
- All cultured cells exposed to or transformed by a primate oncogenic virus.
- All clinical materials, such as samples of human tissue obtained from surgery, biopsy, or autopsy.
- All primate and sheep tissue.
- All uncharacterized cultured cells new to the laboratory until proven to be free of infectious agents.
- All virus-containing primate cultured cells.
- All mycoplasma-containing cultured cells.

The Biosafety Program has developed additional “Agent Specific Fact Sheets” that are available online.

## Chapter 3

### List of Regulations and Guidelines

The following is a summary of federal, state, and local agencies regulations and guidelines that either regulate or provide guidelines covering the use of biological agents:

- Centers for Disease Controls and Prevention and the National Institutes of Health: *Biosafety in Microbiological and Biomedical Laboratories* (BMBL), 5<sup>th</sup> Edition, 2007. This document contains guidelines for microbiological practices, safety equipment, and facilities that constitute the four established biosafety levels. The BMBL is generally considered the standard for biosafety and is the basis for this manual.
- National Institutes of Health: *Guidelines for Research Involving Recombinant DNA Molecules* (NIH Guidelines). This document provides guidelines for constructing and handling recombinant DNA molecules (rDNA) and organisms containing rDNA. Although these guidelines are not subject to regulatory enforcement, institutions that receive any NIH funding for rDNA research are required to comply with these guidelines as a condition of funding. This document requires that each institution establish an Institutional Biosafety Committee with the authority to approve proposed rDNA research using the NIH guidelines as the minimum standard.
- Occupational Safety and Health Administration: *Bloodborne Pathogens*. This regulation covers occupational exposure to human blood and other potentially infectious materials, including human tissue and cells. OSHA specifies a combination of engineering controls, work practices, and training to reduce the risk of infection. Personnel potentially exposed to human blood and other potentially infectious material must be offered immunization against hepatitis B and receive annual training. Personnel who work with HIV or hepatitis B in a research laboratory must receive additional training and demonstrate proficiency in working with human pathogens.
- Boston Public Health Commission: [Recombinant DNA Technology: Use Regulations](#) (passed March 22, 1994) and [Biological Laboratory Regulation](#) (passed September 19, 2006). These regulations require that all institutions in the City of Boston that work with recombinant DNA molecules or that operate BSL-3 or BSL-4 laboratories be licensed by BPHC. These regulations require strict adherence to the CDC/NIH guidelines, as well as other regulations that the BPHC's Board of Health and Hospitals may apply. [Disease Surveillance and Reporting Regulation](#) (passed March 30, 2004) requires all institutions in the City of Boston that engage in research with select agents, Risk Group 4 agents, and other agents named by BPHC as high-risk agents to be registered and maintain disease surveillance and reporting programs in effect to minimize potential exposures to these high-risk agents.
- Commonwealth of Massachusetts Department of Public Health: The Center for Environmental Health regulates the storage and disposal of potentially infectious material, and includes requirements for labeling and recordkeeping.

#### **Select Agents Rule**

- Department of Health and Human Services: *42 CFR Parts 42 and 43 Possession, Use, and Transfer of Select Agents and Toxin; Final Rule*; and the Department of Agriculture's Animal and Plant Health Inspection Service: *7 CFR Parts 331 and 9 CFR Parts 121, Agricultural Bioterrorism Protection Act of 2002: Possession, Use, and Transfer of Biological Agents and Toxin; Final Rule*. These regulations require institutions that possess, use, or transfer certain biological agents and toxins ("select agents") to be registered and approved by DHHS and/or APHIS. Specific requirements are described in Chapter 10.
- U.S. Department of Transportation and the International Air Transportation Authority: These organizations have strict requirements governing the shipment and transportation of hazardous materials, including biological agents. Chapter 11 provides information on shipping regulations.
- Centers for Disease Control and Prevention: The CDC has established specific regulatory requirements for importation or transportation of etiologic agents, which include a permit application that must be submitted and approved *prior* to any such importations. The federal regulation governing the importation of etiologic agents is USPHS 42 CFR - Part 71 Foreign Quarantine. Part 71.54, Etiologic agents, hosts, and vectors.
- U.S. Department of Agriculture, Animal and Plant Health Inspection Service, and Veterinary Services: USDA, APHIS, and VS regulate the importation of animals and animal-derived materials to ensure that exotic animal and poultry diseases are not introduced into the United States. Generally, a USDA veterinary permit is needed for materials derived from animals or exposed to animal-source materials. Materials that require a permit include animal tissues, blood, cells or cell lines of livestock or poultry origin, RNA/DNA extracts, hormones, enzymes, monoclonal antibodies for *in vivo* use in non-human species, certain polyclonal antibodies, antisera, bulk shipments of test kit reagents, and microorganisms, including bacteria, viruses, protozoa, and fungi. Exceptions to this requirement are human and non-human primate tissues, serum, and blood.
- U.S. Department of Commerce: The DOC has specific regulatory requirements for exportation of biological materials. These regulations are both agent and country specific and must be followed strictly.
- Institutional Biosafety Committee: The IBC has promulgated a number of specific policies and procedures that are incorporated into this document as requirements or have been included as appendices.

## Chapter 4

### Biosafety Principles

The risk of exposure to biological agents in a research environment depends on a number of parameters (e.g., the agent, its virulence, subject's susceptibility, route of transmission, etc.). In general, the biosafety procedures used are designed to prevent such exposures by containing the agents. To properly design the containment, it is important to recognize the potential routes of transmission for the given agent.

#### • Routes of Transmission

##### *Skin and Mucous Membrane Contact*

Low-energy procedures, such as decanting of liquids, pipetting, removal of screw caps, vortex mixing, streaking agar plates, and inoculation of animals, can result in the generation of infectious droplets, as well as direct contact with infectious material. Eye contact is also considered a route of exposure.

##### *Ingestion*

Mouth pipetting presents the highest risk for ingestion of infectious material. Splashing of material into the mouth and indirect oral exposure through touching the mouth with contaminated hands can also result in the ingestion of infectious material. Storage of food or drinks in laboratories working with biological agents, as well as storage of utensils and eating and drinking in the lab, can also result in ingestion of infectious material.

##### *Percutaneous Inoculation*

Use of syringes and needles are considered the greatest risk of exposure through inoculation. Inoculation can also occur as a result of cuts and scratches from contaminated items, as well as animal bites.

##### *Inhalation*

Many procedures have the potential for generation of respirable aerosols, including sonication, centrifugation, "blowing out" of pipettes, heating inoculating loops, and changing litter in animal cages.

#### • Containment

The term "containment" is used to describe safe methods for managing infectious agents in the laboratory environment where they are being handled or maintained. The purpose of containment is to reduce or eliminate exposure of laboratory workers, other people, and the outside environment to potentially hazardous agents. The three elements of containment include laboratory practice and technique, safety equipment, and facility design

##### *Primary Containment*

The protection of personnel and the immediate laboratory environment from exposure to infectious agents is provided by good microbiological technique and the use of appropriate safety equipment, such as biological

safety cabinets. The use of vaccines may provide an increased level of personal protection for certain pathogens.

### ***Secondary Containment***

Protecting the laboratory's external environment from exposure to infectious materials is accomplished by a combination of facility design and operational practices. The risk evaluation of the work to be done with a specific agent will determine the appropriate combination of these elements

#### **• Safety Equipment**

Safety equipment includes biological safety equipment, enclosed containers, safety centrifuge cups, and other engineered controls designed to minimize exposure to biological agents. Biological safety cabinets are the most important safety equipment for protection of personnel and the laboratory environment, and most also provide product protection. Safety equipment is most effective at minimizing exposure when workers are trained on the proper use of such equipment and the equipment is regularly inspected and maintained.

### ***Biological Safety Cabinets (BSC)***

Proper use of a biological safety cabinet (BSC) provides a high level of containment that protects the operator from exposure while providing some protection from contamination of the material being handled within the work environment.

Because of its importance in providing containment and safety protections in the laboratory, a BSC is considered one of the most critical pieces of safety equipment in biological laboratories. BSCs are designed to contain aerosols generated during work with biological material through the use of laminar air flow and high efficiency particulate air (HEPA) filtration. Three types of BSCs (Class I, II, and III) are used in laboratories. Open-fronted Class I and Class II BSCs are partial containment devices that provide a primary barrier offering significant levels of protection to laboratory personnel and to the environment when used in combination with good laboratory technique.

The Class I BSC is suitable for work involving low-to-moderate risk agents where there is a need for containment, but not for product protection. It provides protection to personnel and the environment from contaminants within the cabinet but does not protect the work within the cabinet from "dirty" room air.

The Class II BSC protects the material being manipulated inside the cabinet (e.g., cell cultures, microbiological stocks) from external contamination. It meets requirements to protect personnel, the environment, and the product. The two basic types of Class II BSCs are Type A and Type B. The major differences between the two types may be found in the percent of air that is exhausted or recirculated and the manner in which exhaust air is removed from the work area.

The gas-tight Class III BSC, or glove box, provides the highest attainable level of protection to personnel, the environment, and the product. It is the only unit that provides a total physical barrier between the product and personnel. It is used with high-risk biological agents and when absolute containment of highly infectious or

hazardous material is required.

It is important to note that horizontal laminar flow benches *must not* be utilized for work with biohazardous or chemically hazardous agents. These units provide *product protection* by ensuring the product is exposed only to HEPA-filtered air. They do not provide protection to personnel or the ambient environment.

BSCs used as primary barriers must be certified annually by a qualified vendor. Contact the Biosafety Office for information about vendors or other BSC-related information.

Proper operation and maintenance of a BSC requires knowledge of how the system operates, as well as training and experience in effective techniques for working within the cabinet volume without compromising its functions. Additional details concerning the design and use of BSCs are provided in Appendix C.

Two specialized forms of quality control are strongly recommended for all BSCs and are required for cabinets used to contain Risk Group 2 or higher agents:

- At least daily, or each time the cabinet is operated, the operator or user should observe the magnahelic gauge and note its relative position. Magnahelic gauges measure the pressure drop across the outlet HEPA filter and are important indicators of filter integrity. The gauge will typically indicate the same measurement over a long period of time. A significant change in the reading over a short period of time may indicate clogging or a leaking filter. In such cases, the hood should not be used until the problem is identified and resolved. ***If the BSC located within a laboratory does not have a magnahelic gauge, users must understand the operation of the airflow monitor, controls, and alarm settings.***
- Annually, the cabinet should be certified by an outside contractor. OEHS does not offer this service but can provide names and telephone numbers of local certifiers. The certification process is quick and relatively inexpensive and ensures that the hood is meeting its operating specifications and providing maximum protection. In addition, certifiers provide service and preventive maintenance for cabinets and can often forecast expensive requirements like HEPA filter replacements, allowing PIs to budget for the event. PIs who don't have their hoods recertified annually are sometimes faced with large, unanticipated expenses that could have been predicted.
- If BSC recertification is required, the recertification must be completed before the current certification expires. If the certification lapses, the BSC may not be used for BSL-2 or higher procedures until recertified and may be labeled "Non-Certified for Use as a Biosafety Cabinet" by BSO or OEHS. Unless a good reason exists for more frequent certification, a one-year certificate life is appropriate. The certificate will generally expire on the last day of the month in which the certification was performed, one year later (for example, a certificate issued on June 2, 2007 will expire on June 30, 2008).

### ***Personal Protective Equipment (PPE)***

Personal protective equipment (PPE) includes safety eyewear, face shields, gloves, appropriate respiratory protection, and lab coats. This equipment is used to supplement the containment provided by laboratory

practices and safety equipment. PPE is considered the least desirable primary containment method because its failure results in direct exposure of personnel to the biological agent.

**Note:** *PPE is designed to protect laboratory workers from serious exposure to biohazardous materials and should be used in conjunction with appropriate engineering and administrative controls. At a minimum, staff must use lab coats, safety glasses, and gloves whenever there is a potential for skin contact, splash, or aerosols.*

#### • Facility Design

The design of a facility is important in providing a barrier to protect people working inside and outside the laboratory, as well as to protect people or animals in the community from infectious agents that may be accidentally released from the laboratory. Facility design must be commensurate with the laboratory's function and the recommended biosafety level for the agent being used or stored.

The recommended secondary barrier(s) will depend on the risk of transmission of specific agents. For example, the exposure risks for most laboratory work in BSL-1 and BSL-2 facilities will be direct contact with the agents or inadvertent contact exposures through contaminated work environments. Secondary barriers in these laboratories may include separation of the laboratory work area from public access; availability of decontamination equipment (e.g., autoclave\*); and handwashing facilities. In BSL-3 facilities, additional safeguards, such as airlock-controlled entry and exiting, as well as shower facilities, will be required.

As the risk for aerosol transmission increases, higher levels of primary containment and multiple secondary barriers may become necessary to prevent infectious agents from escaping into the environment. Such design features could include specialized ventilation systems to ensure directional airflow; air treatment systems to decontaminate or remove agents from exhaust air; controlled access zones; an airlock at the laboratory entrance; or separate buildings or modules for physical isolation of the laboratory building itself.

**\*Note:** *It is IBC policy that autoclaves used to sterilize biohazardous materials be validated monthly using a sporulation test and that validation records be kept (see Appendix D). Biohazardous materials can also be disposed of in a red bag as medical waste without autoclaving.*

#### • Biosafety Levels

Four biosafety levels (BSLs) represent combinations of laboratory practices and techniques, safety equipment, and laboratory facilities. Each combination is specifically appropriate for the operations performed and the documented or suspected routes of transmission of the infectious agents, as well as for the laboratory function or activity. The recommended biosafety level for an organism represents the conditions under which the agent can be ordinarily handled safely.

NIH's *Guidelines for Research Involving Recombinant DNA Molecules* classifies "human etiologic agents" on the basis of their relative pathogenicity. Agents are categorized into four risk groups (RG).



As a general rule, a biosafety level should be used that matches the highest RG classification of the organisms involved. For example, work with vaccinia virus, a Risk Group 2 (RG2) agent, should be conducted at BSL-2 or higher; simultaneous work with *E. coli* (RG1), Epstein-Barr virus (RG2), and *Mycobacterium tuberculosis* (RG3) should be conducted at BSL-3.

Descriptions of biosafety levels, as well as assigned biosafety levels for specific organisms, are contained in the CDC/NIH document, *Biosafety in Microbiological and Biomedical Laboratories* (BMBL). The BMBL outlines four biosafety levels, summarized below:

Biosafety Level	Agents	Practices	Safety Equip.	Facilities
1	Not known to cause disease in healthy adults; RG1	Standard microbiological practices	None required	Open bench top, sink required
2	Associated with human disease, which is rarely serious and for which preventive or therapeutic interventions are <i>often</i> available; RG2	BSL-1 practice plus: Limited access  Biohazard warning signs  Sharps precautions  Biosafety manual	<i>Primary barriers:</i> Class I or II BSCs or other containment used for manipulations of agents that cause splashes or aerosols of infectious materials. <i>PPE:</i> lab coats; gloves; eye/face protection as needed.	BSL-1 plus: Autoclave available
3	Associated with human disease for which preventive or therapeutic interventions <i>may be</i> available; RG3	BSL-2 practice plus:  Controlled access  Decontamination of all waste  Decontamination of lab clothing before laundering	<i>Primary barriers:</i> Class I or II BSCs or other physical containment devices used for all manipulations of agents. <i>PPE:</i> protective lab clothing; gloves; respiratory protection as needed.	BSL-2 plus: - Physical separation from access corridors - Self-closing, double-door access - Exhausted air not recirculated - Negative airflow into

		Baseline serum		laboratory
4	Agents are likely to cause serious or lethal human diseases for which preventive or therapeutic interventions <i>are not usually</i> available; RG4	BSL-3 practices plus:  Clothing change before entering Shower on exit All material decontaminated on exit from facility	<i>Primary barriers:</i> All procedures conducted in Class III BSCs or Class I or Class II BSCs <u>in combination with</u> full-body, air-supplied, positive-pressure personnel suit.	BSL-3 plus: - Separate building or isolated zone - Dedicated supply/exhaust, vacuum, and decontamination systems - Other requirements outlined in BMBL

**Note:** Consult the BMBL for a more complete description of the four biosafety levels, as well as recommended biosafety levels for specific organisms.

In addition to the four biosafety levels described above, there are also four biosafety levels for work with infectious agents in vertebrate animals, sometimes referred to as the Animal Biosafety Level (ABSL).

BSL	Agents	Practices	Safety Equipment (Primary Barriers)	Facilities (Secondary Barriers)
1	Not known to consistently cause disease in healthy human adults; RG1	Standard animal care and management practices, including appropriate medical surveillance programs.	As required for normal care of each species.	Standard animal facility  No recirculation of exhaust air  Directional air flow recommended  Handwashing sink recommended
2	Associated with human disease; RG2	ABSL-1 practices plus: Limited access  Biohazard warning signs  Sharps precautions	ABSL-1 equipment plus primary barriers: containment equipment appropriate for animal species. <i>PPE:</i> laboratory coats, gloves, face, and respiratory protection as	ABSL-1 facility plus: Autoclave available  Handwashing sink available in the animal room.

		<p>Biosafety manual</p> <p>Decontamination of all infectious wastes and of animal cages prior to washing</p>	needed.	Mechanical cage washer used
3	<p>Indigenous or exotic agents with potential for serious health effects; RG3</p>	<p>ABSL-2 practices plus:</p> <p>Controlled access</p> <p>Decontamination of clothing before laundering</p> <p>Cages decontaminated before bedding removed</p> <p>Disinfectant foot bath as needed</p>	<p>ABSL-2 equipment plus:</p> <p>Containment equipment for housing animals and cage dumping activities</p> <p>Class I or II BSCs available for manipulative procedures (inoculation, necropsy) that may create infectious aerosols.</p> <p><i>PPE</i>: appropriate respiratory protection</p>	<p>ABSL-2 facility plus:</p> <p>Physical separation from access corridors</p> <p>Self-closing, double-door access</p> <p>Sealed penetrations</p> <p>Sealed windows</p> <p>Autoclave available in facility</p>
4	<p>Dangerous/exotic agents that pose high risk of life-threatening disease; RG4</p>	<p>ABSL-3 practices plus:</p> <p>Entrance through change room where personal clothing is removed and laboratory clothing is put on; shower upon exiting</p> <p>All wastes are decontaminated before removal from the facility</p>	<p>ABSL-3 equipment plus:</p> <p>Maximum containment equipment (i.e., Class III BSC or partial containment equipment in combination with full body, air-supplied, positive-pressure personnel suit) used for all procedures and activities</p>	<p>ABSL-3 facility plus:</p> <p>Separate building or isolated zone</p> <p>Dedicated supply and exhaust, vacuum, and decontamination systems</p> <p>Other requirements outlined in the text</p>

## Chapter 5

### Laboratory Biosafety Practices

The foundations of protective practices in a laboratory lie in an individual's laboratory experience, technical knowledge, personal work habits, and attitude toward laboratory safety. Unlike administrative controls, which are behaviors dictated by regulation or laboratory policy, the term "protective behavior" is used to define an innate part of each individual worker's personal approach to the laboratory environment. As such, "protective behaviors" form the first and most important line of defense against injury or exposure in the biomedical workplace.

#### • Basic Laboratory Practices

Prudent practices and good techniques are of primary importance in laboratory safety. Both are based on sound technical knowledge, experience, common sense, and an attitude of courtesy and consideration for others.

Techniques and practices spelled out in detail as "Standard Microbiological Practices" in the CDC/NIH's *Biosafety in Microbiological and Biomedical Laboratories* and the NIH's *Guidelines for Research Involving Recombinant DNA Molecules*, as well as in the National Research Council's *Biosafety in the Laboratory - Prudent Practices for the Handling and Disposal of Infectious Materials* (National Academy Press, Washington, D.C., 1989). Many laboratory safety text and reference books also contain good information.

At a minimum, the seven basic rules of biosafety, based on the National Research Council's *Prudent Practices* document, should be the basis of any personal laboratory work ethic. They are noted in Table 1.

**Table 1: Biosafety practices and blocked routes exposure**

<u>Biosafety Practice</u>	<u>Routes of Exposure Blocked</u>
1. Do not mouth pipette.	Inhalation, ingestion, skin, and mucous membrane contact
2. Manipulate infectious fluids carefully to avoid spills and the production of aerosols.	Inhalation, skin, and mucous membrane contact
3. Restrict use of needles, syringes, and other sharps to those procedures for which there are no alternatives; dispose of sharps in leak- and puncture-proof containers.	Percutaneous, inhalation
4. Use lab coats, gloves, safety eyewear, and other	Skin and mucous membrane contact

personal protective equipment.

- |   |  |
|---|--|
| 5. Wash hands after all laboratory activities, following the removal of gloves, and immediately following contact with infectious agents. | Skin and mucous membrane contact             |
| 6. Decontaminate work surfaces before and after use, and immediately after spills.  | Skin and mucous membrane contact             |
| 7. Do not eat, drink, store foods, or smoke in the laboratory.  | Ingestion, skin, and mucous membrane contact |

#### • **Laboratory Practice and Technique**

The most important element of containment is strict adherence to standard microbiological practices and techniques.

Persons working with infectious agents or infected materials must be aware of potential hazards and be trained and proficient in the practices and techniques required for handling such material safely. The PI is responsible for ensuring that laboratory personnel are properly trained; the PI may delegate the provision of training to the laboratory supervisor, but the responsibility remains with the PI.

Each laboratory should develop an operational manual identifying specific hazards that will or may be encountered and specifying practices and procedures designed to minimize or eliminate risks. Personnel should be advised of special hazards and should be required to read and to follow the required practices and procedures. A scientist trained and knowledgeable in appropriate laboratory techniques, safety procedures, and hazards associated with the handling of infectious agents must direct laboratory activities.

When standard laboratory practices are not sufficient to control the hazard associated with a particular agent or laboratory procedure, additional measures may be needed. The PI is responsible for selecting additional safety practices, which must be in keeping with the hazard associated with the agent or procedure.

Laboratory personnel safety practices and techniques must be supplemented by appropriate facility design and engineering features, safety equipment, and management practices.

**Note:** *Although each individual is responsible for his or her own safety, the PI has ultimate responsibility for ensuring that persons working in the laboratory are adequately trained and that they follow the prescribed safety measures.*

### ***Laboratory Housekeeping and Personal Hygiene***

With laboratory space at a premium, dedicated bench space is a rarity. For those who do not have to share work space, personal safety is greatly enhanced by keeping the area neat, clean, and orderly. Injuries and exposures are more likely to occur in poorly maintained, disorderly areas.

If work space is shared, the importance of maintaining a neat, clean area increases significantly. Coworkers must rely on one another to maximize efficiency and safety. Personal materials should be properly labeled, waste discarded, and the shared space disinfected or cleaned prior to leaving it for the next user.

The following guidelines should be observed in the laboratory:

- Routine housekeeping ensures work areas are free of significant sources of contamination and hazards.
- Housekeeping procedures should be based on the highest degree of risk to which personnel and experimental integrity may be subjected.
- Laboratory personnel are responsible for cleaning laboratory benches, equipment, and areas that require specialized technical knowledge.
- Access to exits, sinks, eyewashes, emergency showers, and fire extinguishers must not be blocked.
- The workplace should be free of physical hazards.
- Electrical safety is a priority, especially as it relates to the use of extension cords. Equipment should be properly grounded. Overloaded electrical circuits and the creation of electrical hazards in wet areas are to be avoided.
- Surfaces should be clean and free of infrequently used chemicals, glassware, and equipment.
- Unnecessary items on floors, under benches, or in corners should be removed.
- All compressed gas cylinders should be properly secured.

Personal hygiene, including proper handwashing techniques, is also a means by which to enhance personal protection in the laboratory. Scrubbing immediately after degloving ensures that contamination of the hand by glove micropuncture or prior exposure is neutralized before being spread.

The laboratory is also an inappropriate place to perform personal cosmetic tasks, such as applying makeup, cleaning or trimming fingernails, or brushing hair. These activities provide new opportunities for exposure and contribute to retrograde contamination of the laboratory environment.

#### **• Universal Precautions**

Prudent practices often overlap with a set of practices known as “universal precautions.” The overarching universal precaution espoused by the Bloodborne Pathogens (BBP) Standard (see Appendix L for a list and more detailed discussion of universal precautions) should be adopted by all laboratory personnel.

Universal precautions require that all human blood and tissues be handled as though they are infectious. Adopting and applying universal precautions to all laboratory reagents clearly creates a heightened awareness

of potential risk and adds another level of caution to activities involving reagents.

#### • **Administrative Controls**

Administrative controls are policies and procedures designed to assist with the safe handling of potentially hazardous biological materials.

#### • **Biological Hazard Information**

Laboratory workers must be knowledgeable of the hazards associated with the biological agents present in the laboratory and have hazard information available to them. The following are sources of hazard information for biological agents.

##### ***Microbial Agents***

- The CDC/NIH's *Biosafety in Microbiological and Biomedical Laboratories* (BMBL) has descriptions of biosafety levels and recommended biosafety practices for specific biological agents.
- The Canadian Laboratory Centre for Disease Control maintains Material Safety Data Sheets for microbial agents ([www.phac-aspc.gc.ca/msds-ftss/index.html](http://www.phac-aspc.gc.ca/msds-ftss/index.html)).

##### ***Toxins***

Isolated biological toxins are chemical hazards, although many such toxins produce adverse effects at doses significantly below that of "traditional" laboratory chemicals. Laboratory use of isolated toxins falls under the BU Lab Safety Manual and Chemical Hygiene Plans, and Material Safety Data Sheets (MSDSs) must be maintained and available.

- MSDSs for a specific toxin should be obtained from the vendor upon receipt of the toxin.
- Toxicology textbooks, such as *Casarett & Doull's Toxicology*, are also good sources of hazard information for toxins.

#### • **Written Standard Operating Procedures**

A manual of written standard operating procedures (SOPs) for the laboratory, in combination with this manual and the CDC/NIH publications *Biosafety in Microbiological and Biomedical Laboratories* and *Guidelines for Research Involving Recombinant DNA Molecules*, provide general requirements for working with biological agents. However, because these cover relatively general topics, individual laboratories are required to develop laboratory-specific SOPs that cover the biosafety concerns and laboratory procedures for that particular laboratory.

For example, laboratory-specific SOPs should address safe manipulation of specific organisms, specific exposure control methods, and specific decontamination and waste-handling requirements. Appendix V provides a recommended standard format for SOPs, and laboratories are encouraged to use this format to effectively convey the biosafety information (including use of pictures and illustrations). The laboratory-

specific SOPs do not need to duplicate the more general SOPs contained in this manual or the CDC/NIH documents, but should serve as supplements.

#### • **Security and Inventory of Biological Agents**

In recent years, a number of highly publicized incidents involving biological materials have increased both public concerns and regulatory oversight concerning the security of biological agents. Even though many of the agents used in research laboratories do not pose a real risk to health and safety of the workers or the public, the perception of such risks is of great importance.

At BU and BMC, each PI must develop site-specific criteria that safeguard all biological materials, regardless of their risk group, from unauthorized removal. It is the PI's responsibility to ensure that his or her laboratory implements sufficient security measures and procedures to prevent unauthorized access to biological agents.

**Select agents (see Chapter 10) and other higher-risk microorganisms and toxins must be stored in a locked container, and an inventory must be maintained with sufficient detail to enable identification of missing materials.** In many instances, during the application review process, the IBC will review the proposed acceptable safeguards and either approve or recommend enhancements to the proposed plans.

#### • **Prevention of Aerosols and Droplets**

Handling of liquids or dry powders generally is likely to generate aerosols or droplets. In practice, high-energy procedures, such as centrifuging, mixing, and pipetting, tend to produce respirable aerosols that stay airborne for extended periods and are small enough to be inhaled, while low-energy procedures, including opening containers and streaking plates, produce droplets that settle quickly on surfaces, skin, and mucous membranes.

#### *Utilization of Biological Safety Cabinets*

In general, the following guidelines are recommended when using biological safety cabinets (BSCs):

- The BSC should be certified when it is installed or after it is moved, and annually thereafter (for information on cabinet certification, call the BSO at (617) 638-4263).
- The magnahelic gauge should be checked regularly an indication of a problem. This gauge will normally run at a relatively fixed value. When it deviates significantly, the cabinet should not be used until the cause of the deviation has been identified and fixed.
- Personnel should understand how the BSC works.
- Personnel should be familiar with the safe and effective use of any UV lamps inside the BSC and use appropriate precautions to avoid UV-related injuries.

**Note:** *OEHS has discouraged the use of UV lamps because they have a short half-life and are not generally maintained appropriately.*

- The BSC's protective airflow pattern should not be disrupted. Rapid arm movement, nearby workers, and open laboratory doors may disrupt the airflow pattern and reduce the cabinet's effectiveness.



- Work and the necessary materials should be planned to minimize the need to exit and reenter the work volume.
- Accumulation of materials in the BSC work volume should be minimized to reduce turbulence and ensure proper laminar air flow.
- The BSC should be left running whenever the cabinet is in use.
- Proper disinfectants that avoid damaging the cabinet's interior should be used.
- Work surface should be wiped with 70% ethanol or isopropanol before use. Each item needed for the planned procedures should be wiped off and placed in the cabinet.
- After the work volume is set up, the BSC should run for at least 5 minutes to allow for stabilization of air flow before any procedures are begun.
- If a piece of equipment, such as a centrifuge or blender, will create air turbulence in the BSC, it should be placed in the back one-third of the cabinet. All other work should be stopped while this equipment is operating.
- Open flames should be avoided in the work volume because they create air flow turbulence that may compromise sterility. In addition, the heat buildup may damage the HEPA filters. If a flame is necessary, a burner with a pilot light should be used. Electric devices, such as loop sterilizers, are often satisfactory alternatives to open flames.
- A pan with disinfectant and/or a sharps container should be placed inside the BSC for pipette/sharps disposal. Vertical pipette discard canisters on the floor outside the cabinet should be avoided.
- Contaminated and clean items should be segregated, and personnel should work from "clean to dirty." The figure below shows a typical layout for working in this manner. The biohazardous waste collection bag should be in a rigid container. Do not block air flow into the front and rear exhaust grilles.
- Move arms slowly when removing items from or introducing items into the cabinet work volume.
- Protect the facility vacuum system from biohazards by using dual aspirator flasks in series (A and B) and placing an in-line HEPA filter (C) between the vacuum trap and the source valve (D) in the cabinet:  
**Note:** *OEHS requires that the flasks are placed in a secondary container, such as a nalgene tub.*

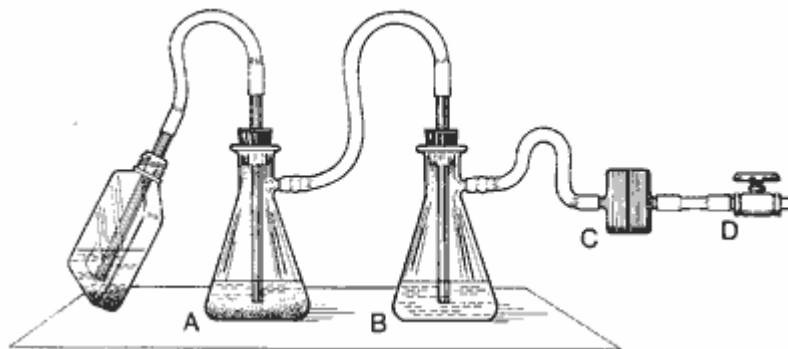

- All spills in the cabinet should be cleaned immediately. Work should not resume for 10 minutes.
- When work is complete, all materials should be removed from the BSC and all interior surfaces should be wiped with 70% ethanol, isopropanol, or other appropriate disinfectants.
- Laboratory coat and gloves should be removed and hands thoroughly washed before leaving laboratory.

### ***Utilization of Pipettes***

Pipettes are used for volumetric measurements and the transfer of fluids that may contain infectious, toxic, corrosive, or radioactive agents. Laboratory-associated infections have occurred from oral aspiration of infectious materials, mouth transfer via a contaminated finger, and inhalation of aerosols. Exposure to aerosols may occur when liquid from a pipette is dropped onto the work surface; when cultures are mixed by pipetting; or when the last drop of an inoculum is blown out.

The following outlines safe pipetting techniques to minimize the potential for exposure to hazardous materials:

- Never mouth pipette. Always use a pipetting aid.
- If working with biohazardous or toxic fluid, confine pipetting operations to a biological safety cabinet.
- Always use cotton-plugged pipettes when pipetting biohazardous or toxic materials, even when safety pipetting aids are used.
- Do not prepare biohazardous materials by bubbling expiratory air through a liquid with a pipette.
- Do not forcibly expel biohazardous material out of a pipette.
- Never mix biohazardous or toxic material by suction and expulsion through a pipette.
- When pipetting, avoid accidental release of infectious droplets. Place a disinfectant-soaked towel on the work surface and autoclave the towel after use.
- Use “to deliver” pipettes rather than “to contain” pipettes, which require “blowout.” Be careful not to dislodge the residual liquid.
- Do not discharge material from a pipette at a height. Whenever possible, allow the discharge to run down the container wall.
- Place contaminated, reusable pipettes horizontally in a pan containing enough liquid disinfectant to completely cover them. Autoclave the pan and pipettes as a unit before processing them for reuse.
- Discard contaminated, broken, or intact Pasteur pipettes and broken glass in a sharps container. Dispose of the container properly when it is, at most, three-fourths full.
- Pans or sharps containers for contaminated pipettes should be placed inside the BSC, if possible.
- Proper procedures for disposal of plastic pipettes are presented in Chapter 9.

### ***Utilization of Centrifugation***

Hazards associated with centrifuging include mechanical failure and the creation of aerosols. To minimize the risk of mechanical failure, centrifuges must be maintained and used according to the manufacturer’s instructions. Users should be properly trained and operating instructions that include safety precautions should be prominently posted on or near the unit.

Aerosols are created by activities such as filling centrifuge tubes, removing plugs or caps from tubes after centrifugation, removing supernatant, and resuspending sedimented pellets. A significant aerosol hazard can be created if a tube breaks during centrifugation.

To minimize the generation of aerosols when centrifuging biohazardous material, the following procedures are recommended:

- Use sealed tubes and safety buckets that seal with O-rings. Before use, inspect tubes, O-rings, and buckets for cracks, chips, erosions, bits of broken glass, etc. Do not use aluminum foil to cap centrifuge tubes because it may detach or rupture during centrifugation.
- Fill and open centrifuge tubes, rotors, and accessories in a biological safety cabinet. Avoid overfilling centrifuge tubes so that closures do not become wet. After tubes are filled and sealed, wipe them down with disinfectant.
- In the event of breakage during centrifugation, the unit should be decontaminated prior to reuse.
- Always balance buckets, tubes, and rotors properly before centrifugation.
- Avoid decanting or pouring off supernatant; unless the supernatant must be retained, use a vacuum aspirator with appropriate in-line reservoirs and filters.
- Work in a biological safety cabinet when resuspending sedimented material. Use a swirling rotary motion rather than shaking. If shaking is necessary, wait a few minutes to permit the aerosol to settle before opening the tube.
- Small, low-speed centrifuges may be placed in a biological safety cabinet during use to reduce the aerosol escape. High-speed centrifuges pose additional hazards. Precautions should be taken to filter the exhaust air from vacuum lines, to avoid metal fatigue resulting in disintegration of rotors, and to use proper cleaning techniques and centrifuge components. Manufacturers' recommendations must be meticulously followed to avoid metal fatigue, distortion, and corrosion.
- Avoid the use of celluloid (cellulose nitrate) tubes with biohazardous materials. Celluloid centrifuge tubes are highly flammable and prone to shrinkage with age. They distort on boiling and can be highly explosive in an autoclave. If celluloid tubes must be used, an appropriate chemical disinfectant must be used.

### *Utilization of Cryostats*

Use of cryostats is very common in many research laboratories. These devices may pose potential hazards associated with sharp cutting edges and cold environments and should be handled with extra care.

The following guidelines should be followed when using cryostats:

- Frozen sections of unfixed human tissue or animal tissue infected with an etiologic agent pose a risk because freezing tissue does not necessarily inactivate infectious agents. Use of freezing propellants under pressure is not recommended with frozen sections because they may cause spattering of droplets of potentially infectious material.
- Appropriate gloves should be worn during preparation of frozen sections.
- When working with human or infected animal tissue, consider the contents of the cryostat to be contaminated and decontaminate it frequently with 70% ethanol.
- Consider trimmings and sections of tissue that accumulate in the cryostat to be potentially infectious and remove them during decontamination.

- Defrost and decontaminate the cryostat with a tuberculocidal hospital disinfectant once a week and immediately after use with tissue known to contain bloodborne pathogens, *M. tuberculosis*, or other infectious agents.
- Handle microtome knives with extreme care. Stainless steel mesh gloves should be worn when changing knife blades.
- Consider solutions used for staining potentially infected frozen sections to be contaminated.

### ***Utilization of Inoculating Loops***

Flaming inoculating loops can result in spatter and the release of aerosols and droplets. Use of an electric microincinerator is more effective in controlling spatter resulting from sterilization of inoculating loops.

### ***Use of Absorbent Materials***

Work surfaces should be covered with absorbent paper or “diaper” sheets to collect splashes and drips and to minimize the spread of contamination. The absorbent paper should be changed at the end of the laboratory procedure as part of the final cleanup, or at least daily during use.

### ***Utilization of Miscellaneous Aerosol-Producing Devices and Activities***

Use of any of the devices listed below results in considerable aerosol production. Blending, cell-disrupting, and grinding equipment should be used in a BSC when working with biohazardous materials.

#### ***Blenders***

Safety blenders, although expensive, are designed to prevent leakage from the bottom of the blender jar. They provide a cooling jacket to avoid biological inactivation and can withstand sterilization by autoclaving.

- If blender rotors are not leak-proof, they should be tested with sterile saline or dye solution prior to use with biohazardous material.
- The use of glass blender jars is not recommended because of the potential for breakage. If they must be used, glass jars should be covered with a polypropylene jar to prevent spraying of glass and contents in the event the blender jar breaks. The blender must be operated within a secondary containment basin.
- A towel moistened with disinfectant should be placed over the top of the blender during use.
- When opening blenders, be cognizant of potential contamination hazards in the form of droplets that might become airborne or fall on the surfaces; liquid residue on the cap; and possible expansion of the volume due to aeration.
- Before opening the blender jar, allow the unit to rest for at least one minute to allow the aerosol to settle.
- Placing the blender in a BSC will provide protection against airborne hazards and placement of a tray lined with absorbent pads would assist with contamination control.
- The device should be decontaminated promptly after use.

### *Lyophilizers*

Depending on lyophilizer design, aerosol production may occur when material is loaded into or removed from the lyophilizer unit.

- If possible, sample material should be loaded in a BSC.
- The vacuum pump exhaust should be filtered to remove any hazardous agents or, alternatively, the pump can be vented into a BSC.
- After lyophilization is complete, all surfaces of the unit that have been exposed to the agent should be disinfected.
- If the lyophilizer is equipped with a removable chamber, it should be closed off and moved to a BSC for unloading and decontamination.
- Handling of cultures should be minimized and vapor traps should be used wherever possible.

### *Sonicators*

Sonication is the use of sound-wave energy for dispersion, disruption, or inactivation of biological materials, such as viruses. Sonicators generate sound waves at very high frequencies (~20,000 + Hz range), which is outside normal hearing range. The following are hazards associated with sonicators:

- *Noise*: Although the 20,000-Hz frequency is outside normal hearing range, there are other sources of noise, such as vibration from any loose equipment or other items on the bench or the liquid itself. If the noise levels are high, normal hearing protection devices should be worn.
- *Aerosols*: Aerosols present a more serious potential hazard and must be taken into consideration. Precautions listed for blenders and lyophilizers should be observed.

### *Ampoules*

Opening ampoules containing liquid or lyophilized culture material should be performed in a BSC to control any aerosol produced. Sealed-glass ampoules used to store biohazardous material in liquid nitrogen have exploded, causing eye injuries. The use of polypropylene tubes (cryovials) eliminates this hazard. These tubes are available dust-free or pre-sterilized and are fitted with polyethylene caps with silicone washers. Heat-sealable polypropylene tubes are also available.

- Gloves must be worn when opening ampoules or cryovials.
- To open a sealed-glass ampoule, nick the neck of the ampoule with a file, wrap it in disinfectant-soaked disposable towel, hold the ampoule upright, and snap it open at the nick.
- Reconstitute the contents of the ampoule by adding liquid slowly to avoid aerosolization of the dried material.
- Mix the contents without bubbling and withdraw it into a fresh container. Discard the disposable towel and the ampoule's top and bottom as medical waste.

### *Loop Sterilizers and Bunsen Burners*

Sterilization of inoculating loops or needles in an open flame generates small-particle aerosols that may contain viable microorganisms.

- Alternatively, disposable plastic loops and needles may be used for culture work where electric incinerators or gas flames are not available.
- Continuous flame gas burners should not be used in a BSC. These burners can produce turbulence that disturbs the cabinet's protective airflow patterns. Additionally, the heat produced by the continuous flame may damage the HEPA filter. If a gas burner must be used, one with a pilot light should be selected. Electric sterilizers should also be considered.

### • **Personal Protective Equipment (PPE)**

Personal protective equipment (PPE) must be provided without cost to personnel. Although not a substitute for the use of BSCs and good laboratory practices, PPE is considered a primary barrier to infectious agents and proper use will reduce the likelihood of infection. PPE is the least-desirable exposure control method because its failure results in direct exposure to the agent.

PPE is most effective when used to supplement primary control methods such as biological safety cabinets, safety centrifuge cups, and other containment devices. Appropriate clothing may also protect the experiment from contamination

The following are considered PPE:

#### ***Face Protection***

Goggles or safety glasses with solid-side shields in combination with masks, or chin-length face shields or other splatter guards, are required for anticipated splashes, sprays, or splatters of infectious or other hazardous materials to the face. Wearing contact lenses is inappropriate in the laboratory setting.

#### ***Laboratory Clothing***

Laboratory coats, smocks, scrub suits, and gowns are considered laboratory clothing.

- Long-sleeved garments should be used to minimize the contamination of skin or street clothes and to reduce shedding of microorganisms from the arms.
- In circumstances where it is anticipated that splashes may occur, the garment must be resistant to liquid penetration to protect clothing from contamination.
- If the garment is not disposable, it must be capable of withstanding sterilization, in the event it becomes contaminated.
- Additional criteria for selecting clothing include comfort, appearance, closure types and location, antistatic properties, and durability.
- Protective clothing must be removed and left in the laboratory before leaving for non-laboratory areas.

- Disposable clothing should be available for visitors, maintenance, and service workers in the event it is required. All protective clothing should be discarded in the laboratory, disinfected, or laundered by the facility.
- Personnel must not launder laboratory clothing at home.

### ***Gloves***

Gloves must be selected on the basis of the hazards involved and the activities to be conducted.

- Gloves must be worn when working with biohazardous and/or toxic materials and physically hazardous agents.
- Temperature-resistant gloves must be worn when handling hot materials, dry ice, or materials being removed from cryogenic storage devices.
- Delicate work requiring a high degree of precision dictates the use of thin-walled gloves.
- When working with hazardous materials, the glove should overlap the lower sleeve and cuff of the laboratory garment. A long-sleeved glove or disposable arm-shield may be worn for further protection of the garment.
- In some instances, double gloving may be appropriate. If a spill occurs, hands will be protected after the contaminated outer gloves are removed.
- Gloves must be disposed of when contaminated, removed when work with infectious materials is completed, and never worn outside the laboratory.
- Disposable gloves must not be washed or reused.
- Protection from contact with toxic or corrosive chemicals may also be required. For assistance in glove selection, call your Department Safety Advisor (DSA).

### ***Respirators***

Respirators are selected based on the hazard involved and the protection factor required. Certain laboratory and clinical situations require respiratory protection to prevent inhalation of infectious agents. Regulations, as well as good safety practice, require that personnel be medically evaluated, specifically trained, and fit tested **prior** to wearing respiratory protective equipment.

Contact OEHS if respiratory protective equipment is required or if there are questions about the respiratory protection program.

**Note:** *Use of respirators requires medical clearance from the Occupational Health Program and fit-testing by OEHS.*

### ***Footwear and Miscellaneous Clothing Guidelines***

Open-toed shoes or sandals are not allowed in the lab. In addition, wearing shorts or other clothing that exposes the lower legs is generally considered unsuitable in laboratories because it increases the potential for skin contamination and absorption of contaminants.

Further guidance on the use of PPE can be found in the Institutional Lab Safety Manual and Chemical Hygiene Plans.

### **Storage and Labeling of Biological Agents**

Biological agents must be stored using double containment. Both the primary and secondary containers must be durable and leak-proof so as to prevent accidental exposure. Primary containers must be clearly labeled with the identity of the agent and should include the universal biohazard symbol (see below) as physical space on the container permits. At a minimum, secondary (or outside) containers must include the universal biohazard symbol (identity of contents is also desirable).

Freezers, refrigerators, and other storage areas must also be labeled with the biohazard symbol; exceptions to this policy will be considered on an individual basis by the IBC. Waste and contaminated equipment or other objects to be decontaminated must also be labeled with the biohazard symbol.

#### ***Universal Biohazard Symbol***

The OSHA Bloodborne Pathogen Standard specifically requires that containers of human blood or other potentially infectious material (OPIM), contaminated waste, and refrigerators, freezers, and other storage containers used to store or transport blood or OPIM be labeled with the universal biohazard symbol (fluorescent orange or orange-red).



#### ***Biohazard Labels and Signs***

Each laboratory must have a sign at the entrance that provides safety information to visitors and service personnel. Room signs must contain designations for all laboratory hazards in use within the laboratory (carcinogens, acutely toxic agents, reproductive hazards, biohazards, radioactive materials, lasers, and magnetic fields). Office of Environmental Health and Safety will prepare the signs for each door in accordance with the requirements of NFPA 704 and BSL-3.

Biohazard signs will be posted at the following:

- Entrances to laboratories and animal rooms that use agents classified as BSL-2 or BSL-3.
- Cages or animal rooms used for housing animals infected with BSL-2 or BSL-3 agents.

For a sample of BU door signage, see Appendix S.

BSL-2 laboratory entrance sign



Certain other areas and pieces of equipment within a laboratory may also require signs. Refrigerators, freezers, cabinets, and other storage facilities require the biohazard symbol whenever they are used to store infectious agents of Risk Group 2 or higher; human blood or blood products; unfixed tissues; cell or organ cultures; body fluids; or excreta. Large pieces of equipment for handling such materials (e.g., centrifuges, biological safety cabinets) must be similarly labeled.

## Chapter 6

### Laboratory Training

Training is a critical component of any integrated biological safety program. Training is intended to provide the understanding, technical knowledge, and tools that the trainee can use to improve his or her daily laboratory safety practices.

At a minimum, all personnel working with biological materials at BU and BMC must have training in the following areas prior to the start of their experiments:

- Knowledge of this biosafety manual
- Experimental procedures to be used
- Decontamination and spill clean-up procedures
- Safe handling methods for any infectious agent and/or recombinant DNA (rDNA) they might be handling
- Proper methods for transporting infectious agents and other biohazardous materials
- Bloodborne Pathogens Standard (if they work with human blood or blood products, unfixed tissue, body fluids, organ, or primary tissue and/or samples contaminated with bloodborne pathogens)
- Boston Public Health Commission requirements (see Appendix P for a summary)
- Other specialized training as deemed appropriate by the IBC or the BSO.

The PI is responsible for ensuring that his or her employees receive proper training in the biohazards and controls specific to his or her laboratory and the safe conduct of the experimental procedures to be used. The Biosafety Program provides different types of training associated with the BU and BMC biological, chemical, and radiological safety programs. Each of these has its own driver and emphasis.

#### • Mandated General Biosafety Training

This training is required by law and/or policy and must be obtained through the BSO because of the regulatory aspects that must be included. An example of mandated general biosafety training is initial bloodborne pathogens training and annual retraining (see Appendix L Bloodborne Pathogen Standard).

Mandated general biosafety training is required for all laboratory workers (faculty, staff, students, and visiting scientists) at BU and BMC. The exact training required for a particular person will depend on the hazards to which he or she is exposed. "Laboratory Safety Training" is a training program offered by OEHS that is designed for those working in laboratories.

New employees, faculty, and staff must attend this training program immediately following their hiring or as soon as practical and before beginning laboratory work. Attendance at new employee orientation does not fulfill this requirement. Training includes, but is not limited to, laboratory safety practices, biosafety, chemical safety, bloodborne pathogens, and hazardous waste operations.

#### • Laboratory Safety Training

Laboratory safety training satisfies the basic competency regulatory requirements for those working in labs. It does not satisfy the need for department-specific training, shipment of infectious agents, select agents, Biosafety Level 3 work, or other specialized training.

#### • **Mandated Specific Training**

Mandated specific training is also required by law and/or policy. In some cases, it is administered and tracked by BSO or OEHS, which maintains the record files. Examples of mandated specific training include non-human primate users training, tularemia, or other specific training required by the IBC or BPHC. Individuals working in laboratories classified as BSL-3 and above, or who are potentially exposed to zoonotic diseases, must also undergo training.

Training laboratory personnel in the unique hazards, equipment, and procedures for a given laboratory is the responsibility of the PI or laboratory manager to administer, document, and track. This training is mandated and must be provided by the PI or laboratory manager on a periodic basis to all laboratory personnel. Documentation is also required and must include at least the date and duration of training, name and position of the trainer, topics covered, and names of the trainees.

#### • **HIV/HBV Laboratory Training**

Personnel who work in research laboratories that culture, produce, or otherwise perform microbiological manipulation of human immunodeficiency virus (HIV) or hepatitis B virus (HBV) must receive additional training beyond the standard bloodborne pathogen training. Prior to working with HIV or HBV, laboratory workers must demonstrate proficiency in standard microbiological techniques, and in the practices and techniques specific to the laboratory. Additionally, workers must have prior experience in handling human pathogens before working with HIV or HBV.

Personnel who do not have experience with human pathogens must be trained in the laboratory before working with HIV or HBV. Initial training must not include the use of infectious agents; rather, training and work activities should be progressive as proper techniques are demonstrated. Workers are permitted to handle infectious agents only after demonstrating proficiency to the laboratory supervisor's satisfaction. Although this specialized, laboratory-specific training is the laboratory supervisor's responsibility, the training should be coordinated with the BSO to ensure proper documentation and recordkeeping.

#### • **Packaging and Shipping of Infectious Agents Training**

Personnel who package and ship infectious agents and diagnostic specimens such as microorganisms, blood samples, and clinical samples for pathological testing are required by federal and international regulations to receive training every two years. OEHS offers this training periodically and upon request.

#### • **Select Agents Training**

Personnel authorized to use select agents are required to receive training. This training is designed to meet the specific requirements of the 42 CFR 73 requirements and must be completed prior to any individual can work with select agents; in addition there is an annual refresher course that all authorized individuals must attend in order to continue with their ability to work with select agents. OEHS and the lab will maintain copies of the training records for reference.

Contact the BSO for more information.

- **Biosafety Level 3 Training**

Specialized BSL-3 training is required for individuals who work in a BSL-3 containment lab or in the BSL-3 biocontainment facility (see Appendix F). Contact the BSO for more information.

- **Laboratory-Specific Training**

Individual laboratories are required to develop specific training for the particular agents and procedures that personnel will perform in that laboratory. This training should be specific to the hazards in the laboratory and to each person's laboratory duties. Each person in the laboratory must understand the hazards associated with laboratory operations, how to prevent exposures to biological and chemical agents (see Laboratory Safety Manual and Chemical Hygiene Plans), and exposure evaluation procedures. Laboratory-specific training should not duplicate the general biosafety training, but instead should supplement it.

Each laboratory must maintain training records. The records should include the names and signatures of the instructor(s) and laboratory personnel, signature of the PI (if not the instructor), topic of training, and date that training was conducted. The information should be recorded on a documentation form and maintained by the laboratory. Ongoing training is required as new hazards and procedures are introduced into the laboratory. The occurrence of spills, spread of contamination, near misses, etc., also indicate the need for refresher training.

- **Other Safety Training**

Personnel who utilize hazardous chemicals, radioisotopes, or x-ray generating devices must attend additional laboratory safety trainings.

- **Refresher Training**

All laboratory workers and certain categories of building occupants will be subject to periodic mandatory refresher training. The scope and details of these refresher trainings will be determined by the IBC and will range from annually (for high-risk areas, such as BSL-3 and BSL-4 laboratories, or those required by regulatory mandates, such as Bloodborne Pathogen Standard or Select Agents Rule) to every three years (for low-risk operations, such as BSL-1).

• **Nonuser Training**

Individuals employed in high containment facilities (BSL-3 and BSL-4) but who are not working with biological materials (e.g., administrative staff, facilities, security, etc.) are also required to attend mandatory training programs. The scope and content of these training programs will be developed based on the needs of each facility.

## Chapter 7

### Decontamination and Sterilization

**Decontamination** is a process or treatment that renders a device, instrument, or work surface safe to handle. A decontamination procedure can range from sterilization by autoclave or ethylene oxide to simple cleaning with soap and water. Sterilization, disinfection, and antisepsis are all forms of decontamination.

**Sterilization** is the use of a physical or chemical procedure to destroy all microbial life, including highly resistant bacterial endospores.

**Disinfection** eliminates virtually all pathogenic, non-spore-forming microorganisms but not necessarily all microbial forms on inanimate objects (work surfaces, equipment, etc.). Effectiveness is influenced by the kinds and numbers of organisms, the amount of organic matter, and the object to be disinfected and chemical exposure time, temperature, and concentration.

**Antisepsis** is the application of a liquid antimicrobial chemical to skin or living tissue to inhibit or destroy microorganisms. It includes using germicidal solutions for swabbing an injection site on a person or animal and for handwashing. Although some chemicals may be utilized as either a disinfectant or an antiseptic, adequacy for one application does not guarantee adequacy for another. Manufacturers' recommendations for appropriate use of germicides should always be followed.

#### • General Procedures

Decontamination of cultures and objects contaminated by biological agents is routinely performed in microbiological laboratories. Decontamination is a vital component of microbiological safety practice and serves to protect laboratory personnel (as well as others) from infection and the release of infectious organisms to the outside environment (primarily through person-to-person transmission). Decontamination of media, work surfaces, and equipment is also necessary to prevent contamination of cultured organisms.

- All infectious materials and all contaminated equipment or apparatus should be decontaminated before being washed, stored, or discarded. Autoclaving is the preferred method. Each individual working with biohazardous material should be responsible for its proper handling.
- A disinfectant should be chosen that is appropriate for the organism in use.
- All liquid biological cultures should be deactivated with appropriate disinfectant.
- All solid biological waste should be disposed of in the biohazard waste containers available in every laboratory. This waste is sealed by the laboratory and shipped off-site for sterilization (see Waste Chart posted in the laboratory for more information).
- Waste created in BSL-3 laboratories is required to be autoclaved prior to removal from the laboratory (see Chapter 9).

### ***Methods of Decontamination***

The three main categories of physical and chemical decontamination are heat, liquid disinfection, and vapors and gases.

• **Heat:** Wet heat is the most dependable method of sterilization. Autoclaving (saturated steam under pressure of approximately 15 psi to achieve a chamber temperature of at least 250° F for a prescribed time) is the best method of rapidly achieving destruction of all forms of microbial life.

- In addition to proper temperature and time, prevention of entrapped air is critical to achieving sterility because of air's poor heat transfer properties.
- Material to be sterilized must come into contact with steam and heat. Indicators of proper autoclave operation (e.g., autoclave tape or autoclave-sensitive labels) must be used with each load to visually indicate successful processing.
- Use of autoclave tape alone is not an adequate monitor of the sterilization's success.
- The Massachusetts Department of Health and Human Resources' Medical Waste Management Act has specific quality-control requirements for autoclaves used for sterilization of medical waste. Appendix D describes the procedures for such tests.

• **Liquid disinfection:** A liquid disinfectant (e.g., 1:10 solution of household bleach yielding a final hypochlorite concentration of 0.5%) is used to wipe or soak potentially contaminated materials for a period of time to kill all pathogenic agents present. Each disinfectant requires varying amounts of contact time.

• **Gas and vapor:** Potentially contaminated articles are exposed to a sterilizing gas (e.g., ethylene oxide, or ETO) or vapors from a chemical (e.g., formaldehyde). Because of the hazardous nature of the gases and vapors used, this is not a very common procedure and requires specially designed equipment and facilities.

### ***Autoclaving***

Autoclaving uses saturated steam under pressure (approximately 15 psi) to achieve a temperature in the autoclave of at least 121<sup>0</sup>C (250<sup>0</sup>F). Autoclaving can be used to destroy vegetative bacteria, bacterial spores, and viruses. When decontaminating biohazardous waste, it is recommended that the temperature **in the waste** reach a minimum of 115<sup>0</sup>C for a minimum of 20 minutes. The total processing time required to meet these conditions depends on several loading factors (see below); however, it is recommended that a minimum autoclave cycle of one hour be used when decontaminating waste.

When using an autoclave, the following guidelines should be taken into consideration:

- Biohazardous materials should not be placed in autoclaves overnight in anticipation of autoclaving the next day.
- Autoclaves should not be operated by untrained personnel.
- Special precautions should be taken to prevent accidental removal of material from an autoclave before it has been sterilized or the simultaneous opening of both doors on a double door autoclave.

- Dry hypochlorite, or any other strong oxidizing material, must not be autoclaved with organic materials such as paper, cloth, or oil:

**WARNING!**

**OXIDIZER + ORGANIC MATERIAL + HEAT = POSSIBLE EXPLOSION**

Three factors in combination determine the effectiveness of autoclaving:

*Temperature:* an autoclave uses steam under a pressure of approximately 15 psi to achieve a chamber temperature of at least 121<sup>0</sup>C. Although the autoclave chamber may reach 121<sup>0</sup>C, this does not necessarily mean that the interior of the load will reach this temperature.

*Time:* a minimum autoclave cycle time of 20 minutes at a chamber temperature of 121<sup>0</sup>C (time does not begin as soon as the autoclave cycle is initiated) is commonly recommended for sterilization of clean items. However, the total processing time required to achieve decontamination depends on several loading factors, including the load container (heat transfer properties); the amount of water added to the load; and the weight of the load. For increased loads, an increased cycle time will be required to ensure effective decontamination.

*Contact:* steam saturation is essential for maximum heat transfer. Steam must contact all areas of the load. Autoclave bags and other containers should be left partially open (or otherwise permit entry of steam) to ensure adequate contact. Studies have shown that adding water to the interior of the bag improves the time-temperature profile of the autoclave cycle, thereby increasing the autoclave's sterilization efficiency.

***Dry Heat***

Requiring higher temperature and longer contact time, dry heat is less effective than moist heat (autoclaving). Nevertheless, dry heat is preferable to moist heat for decontamination of anhydrous materials and closed containers because the moisture component of the steam used in an autoclave will not effectively penetrate anhydrous materials and closed containers.

The highest dry heat equivalent temperature that these materials will reach in an autoclave is 121<sup>0</sup>C. The highest temperature that material will reach in a dry heat oven will be the actual temperature inside the oven. A temperature of 160<sup>0</sup>-180<sup>0</sup>C for three to four hours is recommended for decontamination of waste using a dry heat oven.

***Chemical Disinfection***

Disinfection is the decontamination of work surfaces, equipment, biological safety cabinets, and other inanimate objects using antimicrobial agents. Several chemical agents are used as disinfectants. Laboratory workers should remember that there are hazards associated with all of these chemical disinfectants.

- Inhalation and skin contact should be minimized, and eye contact avoided.
- Appropriate gloves and safety eyewear should always be worn when handling these chemicals.



BUMC  
Biosafety Manual  
Revised Document  
October 12, 2007

Pertinent information for some of the common chemical disinfectants is summarized in table format at the end of this chapter.

**Summary of Chemical Disinfectants**

Disinfectant	Use Parameters	Effective Against <sup>a</sup>					Important Characteristics	Potential Application
		Vegetative cells	Lipophilic viruses	Tubercle bacilli	Hydrophilic viruses	Bacterial spores		
<b>Alcohol</b> (ethyl, isopropyl)	<i>conc.</i> : 70-85% <i>contact time</i> : 10-30 min.	+	+	+	±		Eye irritant, toxic, flammable, inactivated by organic matter.	Surfaces: work and equipment
<b>Chlorine Compounds</b>	<i>conc.</i> : 0.05-0.5% (commercial bleach □□5%) <i>contact time</i> : 10-30 min.	+	+	+	+	±	May leave residue; corrosive; skin, eye and respiratory irritant; inactivated by organic matter; make up at least weekly.	Spills, equipment surfaces, instruments, glassware, water baths
<b>Quaternary Ammonium Compounds</b>	<i>conc.</i> : 0.1-2% <i>contact time</i> : 10-30 min.	+	+				Toxic, inactivated by organic matter.	Surfaces (work and equipment), BSCs, floor maintenance, glassware, instruments
<b>Phenolic Compounds</b>	<i>conc.</i> : 0.2-3% <i>contact time</i> : 10-30 min.	+	+	+	±		Leaves residue; corrosive; skin, eye and respiratory irritant; toxic; inactivated by organic matter.	Surfaces (work and equipment), BSCs, floors, spills, glassware, instruments, water baths
<b>Iodophor Compounds</b>	<i>conc.</i> : 0.47% <i>contact time</i> : 10-30 min.	+	+	+	±		Leaves residue; corrosive; skin and eye irritant; toxic; inactivated by organic matter.	Surfaces (work and equipment), BSCs, glassware, water baths

Disinfectant	Use Parameters	Effective Against <sup>a</sup>					Important Characteristics	Potential Application
		Vegetative cells	Lipophilic viruses	Tubercle bacilli	Hydrophilic viruses	Bacterial spores		
<b>Formaldehyde<sup>b</sup></b> (Formalin)	<i>conc.</i> : 4-8% <i>contact time</i> : 10-30 min.	+	+	+	+	±	Leaves residue; skin, eye and respiratory irritant; toxic (carcinogen).	Less effective than other disinfectants but can be used for equipment surfaces, glassware, instruments
<b>Glutaraldehyde</b>	<i>conc.</i> : 2% <i>contact time</i> : 10-60 min.	+	+	+	+	+	Leaves residue; skin, eye and respiratory irritant; toxic.	Equipment surfaces, glassware, instruments

a: + = very positive response, ± = less positive response. A blank denotes a negative response or not applicable.

b: due to its irritating characteristics and status as a carcinogen, formaldehyde should not be used without good local exhaust ventilation.

From *Laboratory Safety: Principles and Practices*, second edition, Diane O. Fleming, John H. Richardson, Jerry J. Tulis, and Donald Vesley, eds., American Society for Microbiology, Washington, D. C.

## Chapter 8

### Biohazardous Spill Response

Even with the most careful planning and implementation of a research project, the possibility of an incident or spill involving biological materials exists. The following procedures are intended to provide a planned response to such rare events.

In any spill scenario, the priority of actions is determined by the “PEP” rule - **P**eople, **E**nvironment and **P**roperty. The highest priority is to provide aid to injured personnel and prevent spill area access to others.

Note: the following are the general requirements and guidelines for Biohazardous Spill Response; each BSL-3 and BSL-4 facility will develop site specific procedures.

#### • Preplanning for Biohazardous Spill Cleanup

All spills of biohazardous materials do not represent the same risk to personnel and the environment, making each spill somewhat unique. The volume of a spill is not necessarily a valid measure of the risks involved. For example, dropping a glass vial containing 1.0 ml of lyophilized anthrax spores poses much greater risk to laboratory staff than dropping a 10 liter glass bottle of *Escherichia coli* K-12 culture.

Factors other than volume that must be considered in spill risk assessment include:

- Location (e.g., biohazard cabinet, countertop, floor, equipment)
- Nature (e.g., tip-over, aerosolizing (spray/splash), drop from a height)
- Toxicity/infectivity of spilled material
- Volatility and viscosity of spilled material
- Other properties of material (e.g., pH, normality, temperature)
- Nature of affected surfaces (e.g., absorbent, pitted, smooth)
- Complicating materials (e.g., broken glass, clothing, mixing with other materials)
- Susceptibility of spilled material to neutralization/disinfection

Nevertheless, preplanning of spill response will lower the risk of cleaning up a spill and will increase the likelihood that the spill is handled appropriately. Laboratory supervisors should prepare their laboratory for typical spill scenarios expected in the laboratory. Laboratory workers should be informed of the hazards of the biological agents used in the laboratory, the risk associated with these agents during spill scenarios, how to safely clean up the agents, and how to properly dispose of cleanup materials.

### • **Spill Cleanup Materials**

Each laboratory area should have spill cleanup materials available to respond to the largest spill anticipated for that area. At a minimum, the following spill cleanup materials should be available in the laboratory:

- Gloves (thick, chemical-resistant gloves or double pair of thin, nitrile gloves are recommended)
- Safety goggles (a face shield is strongly recommended to avoid splashes to the nose and mouth)
- Lab coat or smock to protect clothing and body
- Absorbent pads
- Disinfectant appropriate for the agents used in the laboratory
- Forceps or other devices to pick up contaminated material (especially sharps)
- Sharps disposal container
- Autoclavable biohazard bags

The chemical spill kits distributed throughout BU and BMC facilities by OEHS may not be adequate for the response to a biological spill. Additional items needed for the cleanup of biohazardous agents can be maintained in the laboratory.

### • **Biohazardous Spill Cleanup Risk Assessment**

Several factors must be considered when assessing the risk that a spill represents:

- Volume and concentration of the spilled material
- The infectious dose of the spilled material and routes of exposure
- Location of the spill
- Degree of aerosolization of the agent resulting from the spill
- Susceptibility of the spilled material to disinfection
- Nature of the affected surface(s) and its ability to “hide” organisms from disinfection
- Immune status of immediate personnel

As with any spill scenario (biological, chemical, or radiological), **the safety of personnel is the most important consideration**. Cleanup is to begin only after it is determined that the personnel who will cleanup the spill have appropriate knowledge, training, and equipment.

### • **Biohazardous Spill Cleanup Procedures**

The following are general biohazardous spill cleanup procedures that are appropriate for most spill scenarios; however, the appropriate response to any spill is based on an assessment of the risk associated with that particular situation.

If in doubt, immediately call the Medical Campus Control Center at (617) 638-8666 or the CRC OEHS emergency telephone at (617) 353-7233. Both response lines are active 24/7/365.

### ***Biohazardous Spills Inside Biological Safety Cabinets***

- Wear a laboratory coat (disposable recommended), safety glasses, and gloves (appropriate for the biological agent and the chemical disinfectant) during cleanup.
- Allow the BSC to run continually during cleanup.
- Surround the affected spill area with absorbent material to prevent spread of the spill.
- Apply disinfectant appropriate for the biological agent and allow a minimum of 20 minutes contact time (or as directed by manufacturer's instructions). Alcohol or other flammable liquids are not recommended.
- Wipe up the spill with a disposable cloth or a towel soaked with disinfectant.
- Wipe the BSC's walls and work surface, as well as any equipment in the cabinet, with a disinfectant-soaked cloth.
- Place contaminated items in an appropriate container (biohazard waste bag, sharps container, or autoclavable pan with lid for reusable items) for autoclaving.
- Allow non-autoclavable items to have a minimum of 20 minutes contact time with the disinfectant (or as directed by manufacturer's instructions) before removing them from the BSC.
- Remove protective clothing and place in a biohazard waste bag for autoclaving.
- Thoroughly wash hands, forearms, and face with soap and water.
- Allow BSC to run for a minimum of 10 minutes before resuming work in the cabinet or shutting off the cabinet.

### ***Biohazardous Spills in the Laboratory, Outside the Biological Safety Cabinet***

If a **BSL-1 agent** or **less than 100 ml of a BSL-2 agent** is spilled, the following procedures should be followed:

- Remove any contaminated clothing and place in a biohazard waste bag for autoclaving, and wash all areas affected by skin contact with soap and water.
- Wear a long-sleeved gown or lab coat (disposable recommended), shoe covers, safety glasses (face shield also recommended), and gloves (appropriate for biological agent and disinfectant).
- Place absorbent pads over the spill (to absorb liquid), then place a second layer of disinfectant-soaked absorbent pads over the spill.

- Pour additional disinfectant around the spill, being careful to minimize aerosolization, and work from the periphery toward the center, ensuring thorough contact between the spill and the disinfectant. Disinfect all items in the spill area.
- Allow a minimum of 20 minutes contact time (or as directed by manufacturer's directions) with the disinfectant.
- Wipe down all equipment, tools, etc., with disinfectant.
- Place contaminated items in an appropriate container (biohazard waste bag, sharps container, or autoclavable pan with lid for reusable items) for autoclaving.
- Remove protective clothing and place in a biohazard waste bag for autoclaving.
- Thoroughly wash hands, forearms, and face with soap and water. It is recommended that cleanup personnel shower as soon as possible.

If the spill involves a **BSL-3 agent**, or **greater than 100 ml of a BSL-2 agent**, immediately evacuate all personnel from the affected area. Wait for aerosol to settle (usually a minimum of 30 minutes) before entering the spill area. **Exception:** If the laboratory is not under negative pressure, cleanup should begin as soon as possible to minimize the spread of aerosols.

In addition, the following procedures should be followed:

- Notify OEHS as soon as possible for assistance with the cleanup.
- Remove any contaminated clothing and place in a biohazard waste bag for autoclaving and wash all areas affected by skin contact with soap and water.
- Wear a long-sleeved gown or lab coat (disposable recommended), shoe covers, safety glasses (face shield also recommended), and gloves (appropriate for biological agent and disinfectant). For cleanup of a BSL-3 agent, a HEPA-filtered respirator may be required.
- Place absorbent pads over the spill (to absorb liquid), then place a second layer of disinfectant-soaked absorbent pads over the spill.
- Pour additional disinfectant around the spill, being careful to minimize aerosolization, and work from the periphery toward the center, ensuring thorough contact between the spill and the disinfectant. Disinfect all items in the spill area.
- Allow a minimum of 20 minutes contact time (or as directed by manufacturer's directions) with the disinfectant.

- Wipe down all equipment, tools, etc., with disinfectant.
- Place contaminated items in an appropriate container (biohazard waste bag, sharps container, or autoclavable pan with lid for reusable items) for autoclaving.
- Remove protective clothing and place in a biohazard waste bag for autoclaving.
- Thoroughly wash hands, forearms, and face with soap and water. It is recommended that cleanup personnel shower as soon as possible.

### ***Biohazardous Spills Inside a Centrifuge***

- Clear the area of all personnel and allow aerosol to settle (usually a minimum of 30 minutes) before re-entering the area.
- Wear a laboratory coat (disposable recommended), safety glasses, and gloves during cleanup. For a BSL-3 agent, a HEPA-filtered respirator may be required.
- Transfer the rotor and buckets to a BSC for cleanup.
- Using an appropriate disinfectant, thoroughly disinfect the inside of the centrifuge, the rotor, and buckets.
- Discard cleanup materials and protective clothing as biohazardous waste.
- Thoroughly wash hands, forearms, and face with soap and water.

### ***Biohazardous Spills Outside the Laboratory During Transport***

All biological agents are to be transported from the laboratory inside an unbreakable, well-sealed, primary container containing absorbent material that is contained inside a second unbreakable, well-sealed leak-proof container (see Chapter 11 for transportation guidelines). Both the primary and secondary containers must be labeled with the universal biohazard symbol and the identity of the agent. In the event a transport container drops and its contents are spilled, the following procedures should be followed:

- Immediately clear the area of all personnel and secure the area.
- Cleanup should be initiated as soon as possible to prevent spread of aerosol. Attempt cleanup **only** if appropriate cleanup materials and protective clothing are available.



- Notify the Medical Campus Control Center at (617) 638-8666 or the CRC OEHS emergency telephone at (617) 353-7233. Both response lines are active 24/7/365.

**Note:** *Employees should become familiar with other non-spill emergencies, such as fire and medical emergencies. OEHS has developed special emergency flip charts that are located in every lab and provide quick references to employees. Employees should review the charts so that in the event of an emergency, they are familiar with their location and content.*

### ***Site-Specific Spill Procedures***

BSL-3 and BSL-4 facilities have site-specific emergency response and spill response procedures that are part of the facility SOP.

**Note: BPHC is notified of all emergencies in BSL-3 and 4 Facilities.**

### **Spill Response**

When responding to a spill, the following rules should be followed:

- **Tend the injured:** Ensure receipt of immediate medical care and do not attempt to move the injured individual(s) unless ambient conditions become life-threatening. Individuals splashed, sprayed with, or otherwise exposed to human blood or other body fluids or tissues during a spill will need to remove contaminated clothing and utilize basic first aid, washing any wounds immediately.
- **Await assistance:** Unless laboratory personnel are trained and properly supplied with personal protective equipment, **DO NOT** attempt to clean up the spill. Personnel should immediately call the Medical Campus Control Center at (617) 638-8666 or the OEHS emergency telephone number, (617) 353-7233. Both response lines are active 24/7/365.
- **Isolate the spill:** Evacuate the immediate spill area or the entire room in the case of an aerosolizing (splashing or spraying) spill or a spill of volatile material. Prevent others from entering the spill area with barricades or, if necessary, a sentry.
- **Contain the spill:** Place absorbent material around, on, or in the flow path of the spilled material *only if it can be done safely.*
- **Provide information:** Provide the information requested by the Control Center or OEHS personnel and await arrival of the emergency provider.
- **Clean up:** Clean up should take place **ONLY** if laboratory personnel are trained, properly supplied with personal protective equipment, and otherwise able to clean up and disinfect the spill safely.

## Chapter 9

### Biohazardous and Medical Waste Disposal

In the Commonwealth of Massachusetts, biohazardous waste is governed by the Department of Public Health regulation 105 CMR 480, “Storage and Disposal of Infectious or Physically Dangerous Medical or Biological Waste, State Sanitary Code Chapter VIII.”

The regulation defines biohazardous waste as *infectious or physically dangerous medical or biological waste* that because of its characteristics may cause, or significantly contribute to, an increase in mortality or an increase in serious irreversible or incapacitating reversible illness; or pose a substantial present potential hazard to human health or the environment when improperly treated, stored, transported, disposed of, or otherwise managed.

The following types of waste are identified and defined as infectious or physically dangerous medical or biological waste, and shall be subject to the requirements of 105 CMR 480.000:

- **Blood and blood products:** Discarded bulk human blood and blood products in free draining, liquid state; body fluids contaminated with visible blood; and materials saturated/dripping with blood.
- **Pathological waste:** Human anatomical parts, organs, tissues, and body fluids removed and discarded during surgery or autopsy, or other medical procedures and specimens of body fluids and their containers.
- **Cultures and stocks of infectious agents and associated biologicals:** All discarded cultures and stocks of infectious agents and associated biologicals, biotechnological by-product effluents, cultures of specimens from medical and pathological laboratories, cultures and stocks of infectious agents from research laboratories, wastes from the production of biologicals, and discarded live and attenuated vaccines intended for human use.
- **Contaminated animal carcasses, body parts and bedding:** The contaminated carcasses and body parts and bedding of all research animals known to be exposed to pathogens.
- **Sharps:** Discarded medical articles that may cause puncture or cuts, including but not limited to all, used and discarded hypodermic needles and syringes, Pasteur pipettes, broken medical glassware, scalpel blades, disposable razors, and suture needles.
- **Biotechnological by-product effluents:** Any discarded preparations made from genetically altered living organisms and their products. Infectious or physically dangerous medical or biological waste shall be referred to as “Waste” in the subsequent provisions of 105 CMR 480.000.

### • **Biohazardous Waste**

Biohazardous waste includes waste materials derived from cultures and stocks of infectious agents, human pathological wastes, contaminated animal carcasses and body parts, all sharps, and human blood and blood products.

Proper handling and disposal of biohazardous waste is necessary to prevent infection of personnel (laboratory workers, custodians, laboratory visitors, etc.) and release to the environment. OSHA and Commonwealth of Massachusetts regulations (105 CMR 480.000) require that biohazardous waste be properly labeled, stored, and disposed of.

### • **Labeling Biohazardous Waste**

At a minimum, all biohazardous waste must be labeled with the universal biohazard symbol. Additional information, such as the type of waste (such as “sharps” or “liquid waste”) and origin of the waste, is recommended.

### • **Handling and Disposal of Biohazardous Waste**

#### ***Sharps***

Sharps include **all** syringes, lancets, scalpels, and other similar medical instruments (whether or not contaminated), as well as contaminated Pasteur pipettes, broken glass, and other instruments or materials that can cut or puncture personnel.

- Sharps must be collected in rigid containers that are leak-proof and resistant to puncture from the sharps. Sharps containers must be designed so that sharps can be safely introduced into the container but not easily retrieved.
- Containers should be red or orange in color and labeled with the universal biohazard symbol. When the sharps container is approximately 3/4 full, BU/BMC personnel should seal the waste container and it will be picked up by the building facilities custodian.
- CRC personnel should seal the waste container and fill out a pick-up request on the CRC website ([http://www.bu.edu/ehs/biosafety/biowaste\\_pickup\\_request.html](http://www.bu.edu/ehs/biosafety/biowaste_pickup_request.html)). Waste will be picked up by a waste management contractor working for OEHS.

A licensed vendor retrieves the waste from each building at pre-determined intervals to process the waste with an approved sterilization method.

#### ***Uncontaminated Laboratory Glassware and Broken Glass***

Collect uncontaminated laboratory glassware and broken glass in rigid containers (separate from other waste) that will prevent cuts and punctures to personnel. Containers should be labeled “broken glass.” Broken glass is to be disposed of as ordinary trash.

### ***Solid Biohazardous Waste***

Solid biohazardous waste includes microbial agents, tissue culture, and contaminated material (such as petri dishes, pipettes, contaminated glass, etc.). These materials are collected in red biohazard bags that are double-lined and placed in cardboard boxes.

- BU/BMC personnel should seal the waste container for pick up by the building facilities custodian.
- CRC personnel should seal the waste container and fill out a pick-up request on the CRC website ([http://www.bu.edu/ehs/biosafety/biowaste\\_pickup\\_request.html](http://www.bu.edu/ehs/biosafety/biowaste_pickup_request.html)).

A licensed vendor retrieves the waste from each building at pre-determined intervals to process the waste with an approved sterilization method.

### ***Liquid Biohazardous Waste***

Liquid biohazardous waste includes all blood and liquid waste from humans or animals, and all other liquid biohazardous waste (such as microbial cultures). Collect liquid waste in closeable, rigid, plastic, leak-proof containers labeled with the universal biohazard symbol.

- Human and animal blood and body fluids can be disposed of by flushing directly to the sanitary sewer (wear laboratory coat, safety glasses and face shield, and gloves, and be careful to minimize splashing).
- All other liquid waste must be autoclaved or treated with a disinfectant prior to disposal.
- Liquid waste treated with small quantities of bleach or other household disinfectants can be disposed of by flushing directly to the sanitary sewer. Liquid waste treated with other chemical disinfectants must be disposed of as hazardous chemical waste through OEHS.

### ***Animal Carcasses, Body Parts, and Tissue***

All carcasses are to be placed in a red biohazard bag secured with a plastic tie.

- All non-preserved carcasses should be stored in a freezer or cold storage area prior to disposal. **Secure limbs and sharp protrusions** so they do not puncture the bag.
- Animals sacrificed by ether euthanasia can be an explosion hazard upon incineration of the carcass; therefore, ether euthanasia of animals is not normally permitted.
- All BSL-3-generated infectious animal carcasses must be sterilized in a steam autoclave as they are generated. Carcasses may be placed in a storage area only after being rendered non-infectious. Infectious carcasses that are not autoclaved on-site will be disposed of through a commercial infectious waste disposal company.

BUMC  
Biosafety Manual  
Revised Document  
October 12, 2007

A licensed vendor retrieves the waste from each building at pre-determined intervals to process the waste with an approved sterilization method.

## Chapter 10

### CDC/USDA Select Agents

The U.S. Department of Health and Human Services (DHHS) and the U.S. Department of Agriculture's (USDA) Animal and Plant Health Inspection Service (APHIS) regulations require institutions that possess, use, or transfer certain biological agents and toxins (known as "select agents") be registered and approved by DHHS and/or APHIS. DHHS actions are promulgated under the authority of the Centers for Disease Control and Prevention (CDC), and APHIS actions are under USDA enforcement.

The CDC and USDA have identified specific biological agents and toxins they consider to be a severe threat to public health and safety because of their potential use as bioterrorism agents. These materials are referred to as "select agents" by the CDC and as "high-consequence livestock pathogens and toxins and listed plant pathogens" by the USDA. Their transfer, possession, use, and disposal are strictly regulated.

This chapter will refer to all these agents as "select agents." The current list of select agents is provided at the end of this chapter. Because the list of select agents may be revised, it is recommended that the CDC Select Agent Program website and the USDA Agriculture Bioterrorism Protection Act website be checked before acquiring pathogenic agents and biological toxins ([www.cdc.gov/od/sap](http://www.cdc.gov/od/sap)).

The regulations associated with select agents are very complex and strict, and significant monetary fines and criminal penalties are associated with non-compliance. The information in this chapter is a summary of the select agent regulations; it is not a complete description of the regulatory requirements.

**Investigators must review and understand the select agent regulations and their responsibilities prior to acquiring or working with any select agent** (for regulatory information, see [www.cdc.gov/od/sap](http://www.cdc.gov/od/sap)).

#### • Responsible Official and Authorization

##### *Responsible Official*

Select agent regulations require that a Responsible Official (RO) be designated for each institution that possesses and uses select agents. **The RO has institutional responsibility for the biosafety, security, and regulatory compliance of select agents, and as such, must be contacted *prior* to obtaining any select agents.**

##### *Authorization to Possess and Use Select Agents*

Prior to personnel obtaining any select agent, the IBC must review and approve any proposed work. In addition, PIs who want to acquire, possess, or use any biological agent or toxin listed as a select agent **must be registered and approved with the appropriate agency (CDC or USDA) *prior* to obtaining the agent(s) or toxin(s).**

- The appropriate agency must approve both the institution, whether BU or BMC, and the individual laboratory. Investigators who want to possess and use select agents must contact the RO for assistance with the registration application process. Approval by the CDC or USDA can take several weeks to several months, and PIs should plan research projects accordingly.

The select agent regulations contain very strict requirements regarding biosafety, training, emergency response, security and accountability, as well as other requirements. Investigators wanting to acquire select agents should thoroughly review the CDC or USDA select agent regulations (whichever is appropriate) before initiating the registration application process.

#### • Exemptions and Exclusions

Diagnostic labs that do not maintain select agents are largely excluded from the CDC and USDA select agent regulations; however, notification and possession time limits and other requirements do apply. Additionally, the CDC and USDA can grant exclusions for temporary public health emergency situations and other special circumstances. Consequently, any laboratory that conducts diagnostic or verification testing for any select agent must identify itself by contacting the RO as soon as possible. **Identification of any select agent in a specimen or isolate must be reported to the RO as soon as possible.**

Several specific select agent microbial strains and toxin forms have been determined not to present a severe threat to public health and safety, and are therefore excluded from the CDC/USDA select agent regulations. The list of excluded biological agents and toxins is dynamic and the most current list is available on the CDC and USDA select agent websites. Toxins are excluded based on threshold quantities. **Laboratories maintaining exempt quantities of select agent toxins must keep an accurate inventory of toxin amounts to verify that total quantities are below the threshold.**

Within BU and BMC, each select agent laboratory must develop and implement three written plans – security, incident response, and biosafety – that address safety issues associated with that specific select agent.

#### • Security Requirements

##### *Security Plan*

Each select laboratory must have a written security plan that addresses the following topics:

- Physical security
- Cyber security
- Inventory of select agents
- Select agent transfers
- Training
- Reporting of unauthorized persons and missing materials
- Provisions for cleaning, maintenance, and repairs

**Any theft or loss of select agents must be immediately reported to BUMC Security and OEHS**, which will notify the CDC or USDA as appropriate in addition Boston Public Health Commission (BPHC), will also be notified of such events. BU an collaboration with City Agencies (BPHC, Boston Fire Department, Boston Police Department and EMS) has developed an Emergency Notification and After Action Guideline high Risk Materials Matrix outlining the list of agencies and events for which they will be notified. This plan must be available and up-to-date during a CDC inspection.

**The Department of Justice must approve all persons who will have access to any select agent.** Approval requires that each individual successfully pass a background security check (conducted by the FBI in accordance with the USA Patriot Act) and submit fingerprints to the FBI. Anyone who has not been approved for access to select agents must be denied access unless escorted by an approved person. Everyone who enters a laboratory where select agents are accessible must have security approval or be accompanied by an approved person. This includes visiting scientists (BU/BMC or off-campus), maintenance workers, custodians, and vendors.

#### • **Incident Response**

##### *Incident Response Plan*

**Each laboratory that possesses or uses select agents must develop a written emergency plan** that is laboratory specific and coordinated with department, building, and BU/BMC emergency plans. The plan must address the following:

- Hazards of the select agents
- Planning and coordination with emergency responders
- Building evacuation, site security, and control
- Decontamination and emergency medical treatment, and other emergency response issues

Any exposure or potential exposure should be reported immediately, and the BUMC Emergency Response Plan for Select Agent Laboratories and the Biological Spill Response Plan for Select Agent Laboratories implemented.

Affected personnel on the medical campus should immediately report to the Emergency Department or Occupational Medicine in the Preston Building for medical evaluation and treatment; on the Charles River Campus, contact the Occupational Health Center at 930 Commonwealth Avenue.

Laboratory personnel should become familiar with these plans.

#### • **Biosafety and Recordkeeping Plan**

##### *Training of Personnel*

All persons approved for access to select agents must receive documented training covering the following:

- Biosafety of select agents and their safe handling, use, and disposal
- Security requirements and procedures
  
- Inventory and accounting procedures



- Emergency response procedures.

**Training is required before beginning work with select agents and annually thereafter.**

### ***Transfers of Select Agents***

Select agents can only be transferred between entities that are currently approved by the CDC or USDA to possess and use select agents. All transfers of select agents (including intrafacility transfers) require *prior* approval of the CDC or USDA.

Both the sender and recipient must complete a common transfer form (Form 2), and the recipient must submit the completed form to the CDC or USDA. Form 2 requires the signature of the RO at both the sender and recipient facilities. When the select agent is consumed or destroyed, the recipient must notify CDC or USDA through an update of their registration.

### ***Inventory and Disposal of Select Agents***

**An accurate record of all select agents, from receipt to destruction or disposal, must be maintained.**

The inventory must include specific information on individual containers and vials, as well as a record of each use, and ultimate disposal. The select agent inventory must be verified at least monthly to account for all quantities and containers of select agents. Any discrepancies between the inventory record and the actual inventory must be reported immediately to the RO.

### ***Records Required for Select Agents***

Select agent regulations require that several records be maintained, including the following:

- Detailed inventory of each select agent and associated containers
- Access to select agents
- Access to the area where select agents are used or stored
- Safety, security, and emergency response plans
- Training records
- Transfer documents (Form 2)
- Safety and security incident reports

Each individual laboratory is responsible for maintaining these records. OEHS will keep records of any training that it conducts. Laboratories must maintain records of training conducted by laboratory personnel or any other applicable training.

The Biosafety Office will maintain Form 2s and any other CDC or USDA select agent forms; however, laboratories must also maintain copies of these forms. The recordkeeping requirements are complex, and therefore the CDC or USDA regulations should be reviewed for a complete description of the recordkeeping requirements.

### ***Recordkeeping for Select Agent Laboratories***

The following is a list of required recordkeeping for all select agent inventory and access records, per CDC

and USDA regulations.

• **Logbook Inventory**

1. Name, characteristics, source data
2. Quantity of first inventory (toxins only)
3. Quantity acquired, source, date
4. Quantity, volume, mass destroyed or disposed, date
5. Quantity used
6. Transfers: quantity, date, individual
7. Current quantity held
8. Lost, unaccounted for, stolen
9. Written explanation of any discrepancy

• **Access Records**

1. Access to SA: Name, SA, date removed and returned, quantity used (toxins), quantity returned (toxins).
2. Access to Area: Name, date, and time entered and left area; uncleared individuals must be accompanied by approved individuals and recorded as such.

• **Authenticity of Records Verified**

• **Records must be maintained for 3 years.**

• **Further information regarding select agents and records will be given to laboratories working with select agents in specialized safety training by laboratory personnel authorized to work with such agents.**

• **Personnel, Responsibilities, and Procedures for Select Agent Procurement and Receipt**

*Procedure Description*

This Standard Operating Procedure (SOP) establishes the BU and BMC procedures to be followed when obtaining biological agents and toxins that have been designated as “Select Agents” under Federal Regulation (42 CFR 73.0, 7 CFR 331, 9 CFR 121).

This SOP implements the requirements of the BU/BMC Materials Transportation Mitigation Policy as regards “Select Agents.”

*Scope*

This program covers all employees and staff of Boston University Medical Center, including affected PIs, OEHS, the Office of General Services (OGS), the Director of Occupational and Environmental Medicine

(OEM), and the IBC.

### ***Responsibilities***

#### *Office of Environmental Health and Safety (OEHS)*

- Manages and oversees the acquisition and receipt of select agents in accordance with the BU/BMC Materials Transportation Mitigation Policy.

#### *Biosafety Officer (BSO)*

- Provides guidance to BU/BMC personnel and assists in complying with the requirements of the Public Health Security and Bioterrorism Preparedness and Response Act of 2002 (Public Law 107-188).
- Provides required DHHS, USDA, and APHIS/CDC forms and registration/reporting documents necessary for obtaining approval to transfer select agents.
- Communicates directly with CDC Select Agent Program to facilitate transfer approval and to resolve issues.

#### *Responsible Official (RO)/Alternate RO*

- Verifies that each transfer of a select agent complies with Public Law 107-188.
- Verifies that each transfer is authorized and completed, and completes required documentation.
- Documents successful receipt or reports theft, loss, or release as required by regulation.

#### *Occupational Health Officer (OHO)/Designee*

- The OHO conducts medical surveillance of employees working with high-risk agents.
- The Occupational Health Officer is responsible for having in place a general plan to determine whether employees working with various high-risk agents have had a significant exposure to a high-risk agent, as well as a plan to monitor significantly exposed employees. The OHO is also responsible for the existence of a project-specific plan, created in conjunction with the individual laboratory supervisor. The OHO, laboratory supervisor, the IBC, and the OEHS Executive Director must sign off on the plan.
- The Occupational Health Officer reports to the Boston Public Health Commission any laboratory employee or individual having access to the laboratory who has been diagnosed or is exhibiting symptoms of, or may have been exposed to, any high-risk agent within one business day. The OHO will conduct a follow-up assessment and provide the BPHC with additional information requested regarding isolation and/or quarantine issues.

- The OHO will send BPHC information on return to work within three business days prior to the individual's return to work.
- Report of unplanned absence due to illness lasting two or more days involving employees working with high-risk agents must be reported to BPHC within two business days. If the illness is believed to be work related, the evaluation must be completed prior to the employee returning to work, and BPHC must be consulted three business days prior to the employee's expected return to work.
- **The Occupational Health Officer must report any violations of laboratory procedures resulting in the release of a high-risk agent.** The OHO must report to the BPHC any violation or breach of any laboratory procedures or any other incident that the OHO should reasonably believe released a high-risk agent beyond the work area.

See Appendix T for BPHC Disease Surveillance and Reporting Regulations.

- The Occupational Health Officer must provide written notification of any reports submitted to the BPHC to the OEHS Executive Director.

*Principal Investigator (PI)/Authorized Recipient*

- Understands and fully complies with all regulations and BU/BMC procedures involving select agents.

*Executive Director of Public Safety and Operations/Designee*

- Maintains security of locations determined to be appropriate for the receiving, shipping, and storage of designated materials, as well as the screening and examination of vehicles, packages, and personnel.

*Manager of Emergency Planning and Response*

- Provides recommendations related to emergency management planning, training, and response coordination to OEHS, Facilities Management and Planning, the Department of Public Safety, and members of the Emergency Response Team.
- Participates in the development and implementation of emergency response plans, exercises, risk reduction initiatives, and risk prevention measures.
- Serves as the liaison to the Boston Mayor's Office of Emergency Preparedness, as well as to the state of Massachusetts and federal emergency management agencies.

*Institutional Biosafety Committee (IBC)*

- Reviews and approves all projects involving hazardous biological agents and toxins, according to CDC/NIH and the City of Boston Public Health Commission guidelines. For a current listing of IBC members contact the IBC Office at (617) 638-4276.

#### *Occupational and Environmental Medicine*

- Prevents, diagnoses, and treats BU/BMC employees' occupational illnesses and injuries. In conjunction with the IBC, provides medical support to work involving hazardous biological agents and toxins.

#### ***Approval Process***

##### *Initial Request for Select Agent*

- PI notifies the BU/BMC Biosafety Officer that a select agent needs to be ordered at least two weeks before anticipated use date.
  - PI obtains any applicable USDA permits that may be required for the interstate transport of the select agent, and provides permits to RO.
  - PI completes Section A and blocks 30 and 37 of APHIS/CDC Form 2 and forwards it to the BSO.

##### *Biosafety Officer's Review*

- Upon receipt of request to acquire select agent, the BSO:
  - Confirms that the PI is an authorized select agent user.
  - Confirms that IBC approvals, training, and inspection status are valid and current.
  - Confirms that appropriate laboratory and storage facilities are available.
- For *each* transfer, the BSO verifies that the PI has completed Form 2 according to the "Guidance Document for the Report of Transfer of Select Agents and Toxins."
- If review is favorable, forwards the partially completed form to the BU/BMC RO.
- Rejects request if requirements are not met.

##### *Responsible Official's (RO) Approval*

- RO or Alternate RO reviews Form 2 for accuracy and transmits Form 2 to the Sender RO.
- For imported select agents, the RO or Alternate RO works with the PI to obtain any needed USDA and/or U.S. Public Health Service (PHS) permits and completes APHIS/CDC Form 2 as per the "Guidance Document for Report and Transfer of Select Agents and Toxins."

### *Federal Approval*

- Sender receives Form 2 from BU/BMC RO/Alternate RO and completes Section B and blocks 31-36, then transmits Form 2 via facsimile to APHIS/CDC.
- APHIS/CDC corresponds with the recipient (BU/BMC RO/Alternate RO) and the Sender RO as required to support authorization of the shipment.
- APHIS/CDC issues an approval authorization number that is good for 30 days. Faxes approved Form 2 to Recipient (BU/BMC RO) and Sender RO.

### *Shipping Process*

#### *Order Placement*

- The RO receives approval authorization number and completed Form 2 from APHIS/CDC and forwards to BSO.
- RO designates a transporter to be used who meets the selection criteria of the BU/BMC Materials Transportation Mitigation Policy described in Chapter 11, Page 79.
- The BSO, upon receipt of the approved Form 2 and authorization number from the RO, coordinates transport of the select agent from the shipper to BU/BMC using a method that tracks the movement of the select agent being shipped and is in accordance with the BU/BMC Materials Transportation Mitigation Policy. Coordinates shipment details and tracking with transporter.
- Sender coordinates shipment details with BU/BMC BSO. Packages, labels, and ships select agent in accordance with all federal regulations.

Note: All transportation must be in accordance with the specifics of the BU/BMC Materials Transportation Mitigation Policy in effect at the time of the transportations.

#### *Notifications*

- The BSO notifies the following of shipment, date, and time of delivery:
  - RO
  - PI/Authorized User (Recipient)
  - Executive Director of Public Safety and Operations
  - Manager of Emergency Planning and Response
  
  - IBC Chair
  - Chief, Occupational and Environmental Medicine

### *Transportation*

- Transporter accepts, stores, loads and delivers package(s) to the BU/BMC approved location, using approved access routes.
- Transporter reports any and all violations of law, regulation, and/or policy.
- Transporter will contact the relevant State Police department having jurisdiction for any problem or incident that may occur during transit with select agents.

### **Receipt**

#### *Steps Prior to Arrival*

- RO, BSO, and PI verify that appropriate laboratory and/or storage facilities are available.
- RO and Executive Director of Public Safety and Operations or designee review security procedures for receipt and transfer prior to the day of scheduled arrival which includes the means for securing of the loading dock.
- The Executive Director of Public Safety and Operations or designee will ensure that a BU/BMC public safety officer provides escort for the RO and subject materials package.

#### *Arrival and Receipt*

- Upon the transporter's arrival, the RO and Executive Director of Public Safety and Operations or their designee(s) verify identity of drivers and accuracy of the shipping papers.
- RO or designee instructs drivers to wait until the package contents are verified.
- The public safety officer will escort the RO or designee to the approved select agent laboratory.

*Note: if the shipment appears to be damaged the delivery truck will be stopped from moving from the premises and BUMC ERT will evaluate the situation to determine the best course of action. Public agencies (e.g. BPHC, BFD, BPD) will also be notified immediately.*

*The actual course of action will depend on whether or not there is any sign of obvious leakage, the extent of the damage or suspicion that the integrity of the internal packaging container has been compromised. The action taken may include:*

- *Over-packing of the package and removal to the laboratory to check the contents to check the integrity of the inner package*
- *Leaving the container in place for further evaluation by public agencies for additional course of action*
- *Containment of any leakage within the transport vehicle will be achieved by use of appropriate (i.e. effective for the agent) absorbent materials and disinfectants.*

### *Verification of Shipment*

- After donning appropriate personal protection equipment and following established laboratory procedures, the PI and RO or their designee(s) take the unopened package to a previously designated biological cabinet (in a laboratory appropriate for a select agent).
- The PI and RO or their designee(s) examine the package for any signs of tampering, damage, or leakage and then open the package and verify contents.
- The public safety officer will wait outside the laboratory while verification of the shipment occurs.
- If all is in order (no non-conformities) and the contents are verified, the RO or designee finalizes the transporter's shipping papers.

### *Notification and Documentation*

- The RO then completes blocks 41 and 42 of Form 2, faxes, and mails the form *within 24 hours of receipt* to the shipper's RO and APHIS/CDC.
- The PI enters the select agent into inventory per established procedure.

### ***Discrepancies***

#### *Notification*

In the event of a non-conformity with the shipment, the RO will immediately notify:

- 1) The Executive Director of Public Safety and Operations to hold the transporter.
- 2) BU/BMC Manager of Emergency Planning and Response.
- 3) APHIS and/or CDC, BPHC and local law enforcement and the Department of Justice in the event of theft or loss. Complete and transmit APHIS/CDC Form 3.

### ***References***

- APHIS/CDC Guidance Document for Report and Transfer of Select Agents and Toxins (APHIS/CDC Form 2): <http://www.selectagents.gov/formsOverview.htm> • APHIS/CDC Guidance Document for the Report of Theft, Loss or Release of Select Agents and Toxins (APHIS/CDC Form 3): <http://www.selectagents.gov/formsOverview.htm>
- CDC Select Agent website: <http://www.cdc.gov/od/sap/>
- APHIS Agricultural Select Agent website: [http://www.aphis.usda.gov/programs/ag\\_selectagent/](http://www.aphis.usda.gov/programs/ag_selectagent/)
- BU/BMC Materials Transportation Mitigation Policy



## Select Agent Acquisition Approval Process

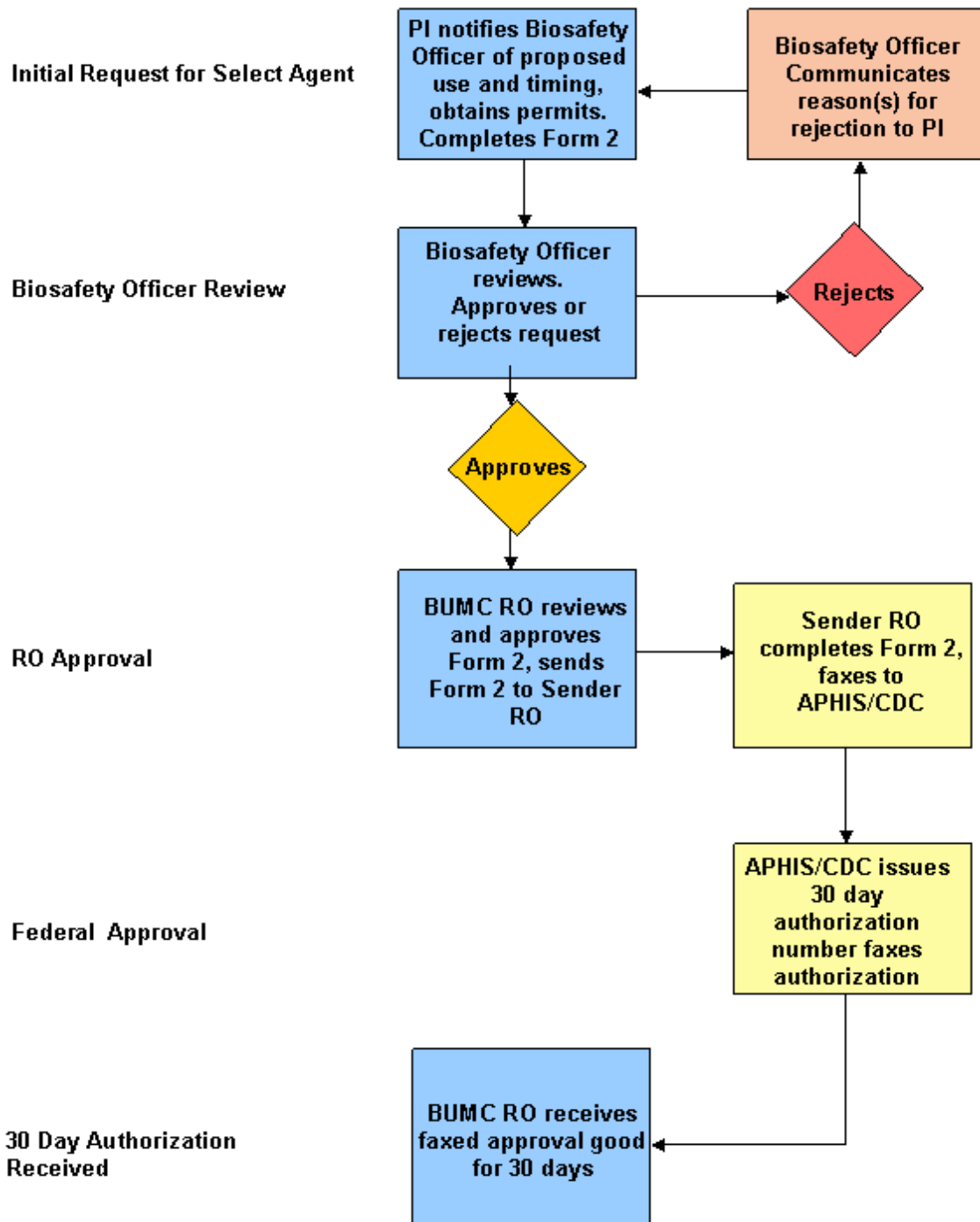

## Select Agent Acquisition Receipt Process

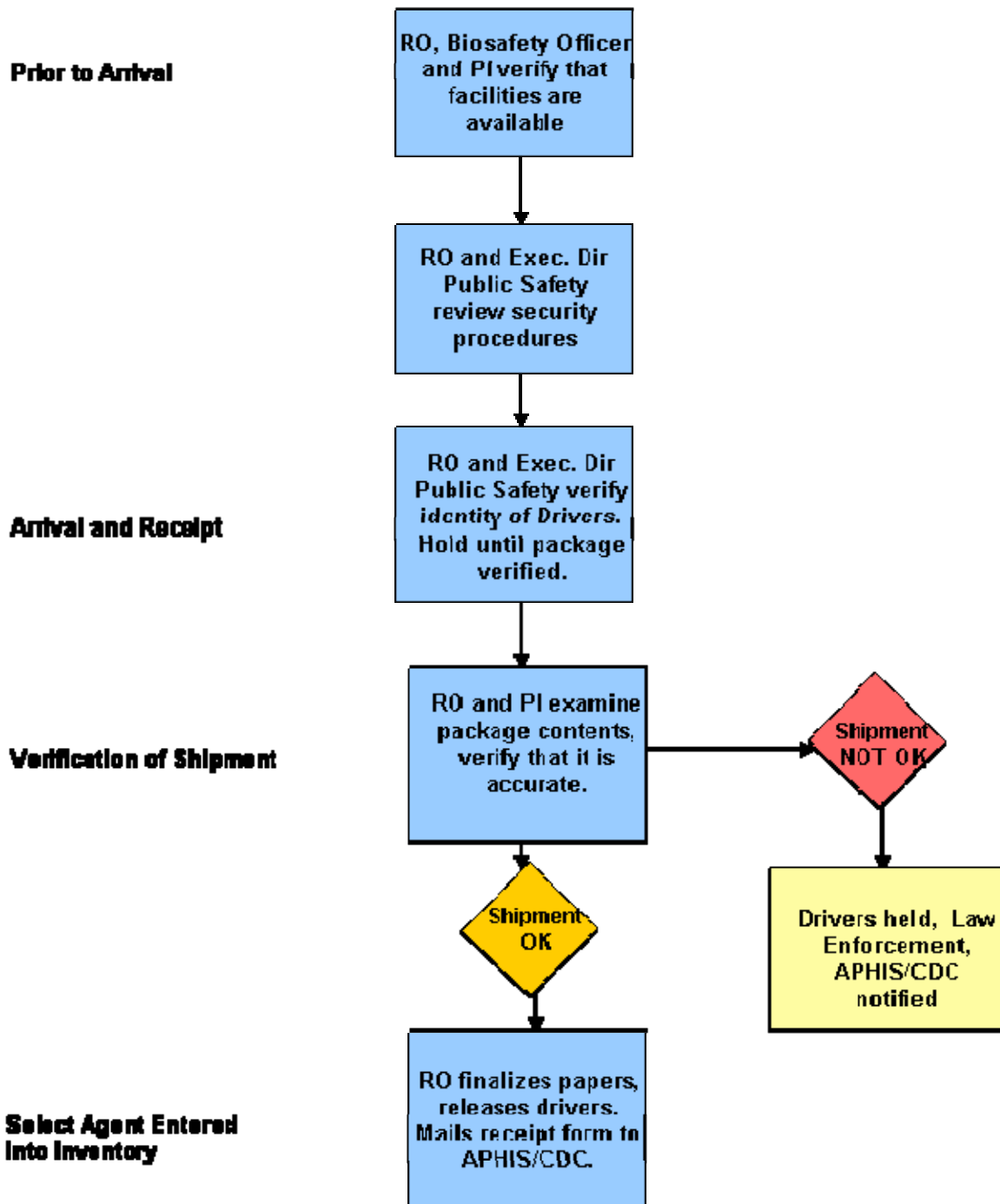

## Select Agent Acquisition Shipping Process

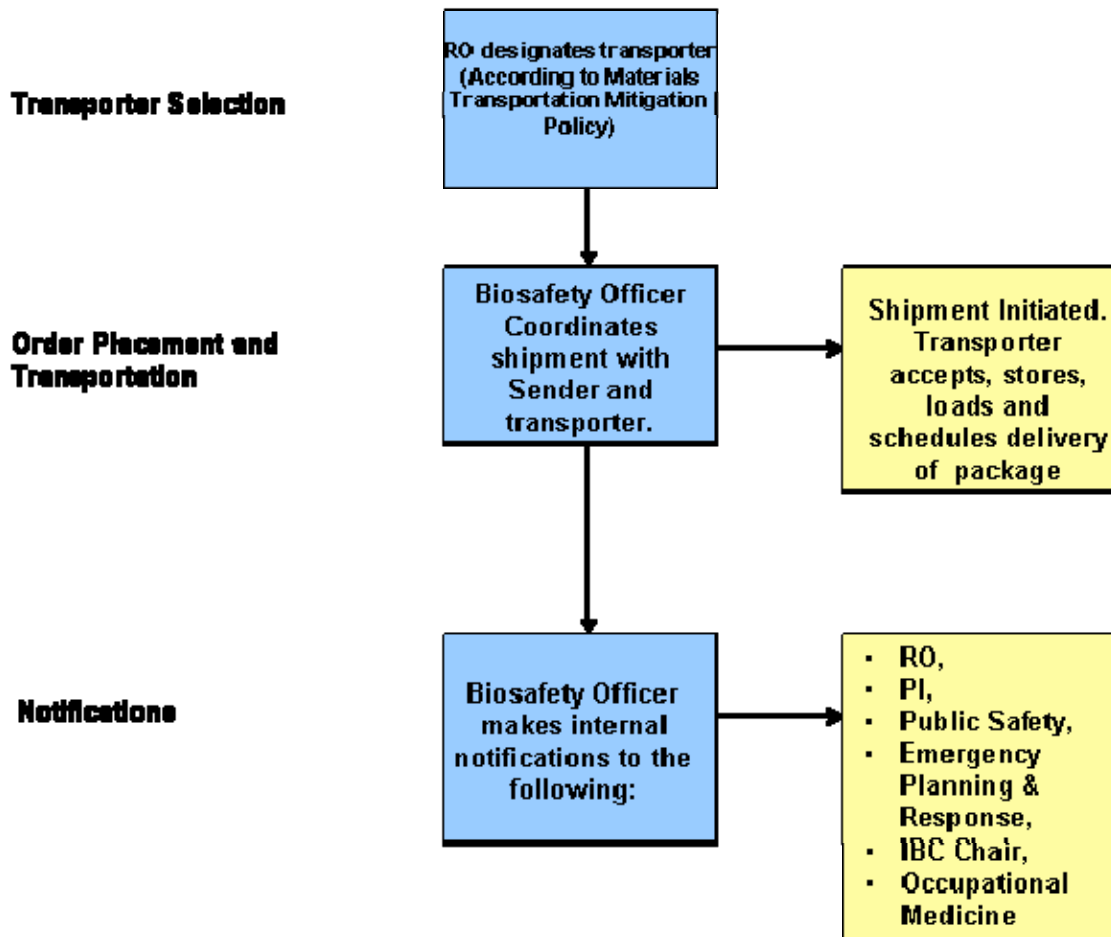

**List of Select Agents\***  
(\* Subject to change by DHHS/APHIS at any time)

**CDC Non-Overlap Select Agents and Toxins Pathogens**

Crimean-Congo haemorrhagic fever virus  
**Toxins)**  
*Coccidioides posadasii*  
Ebola viruses  
Cercopithecine herpes virus 1 (Herpes B virus)  
Lassa fever virus  
pathogenic)  
Marburg virus  
Monkeypox virus  
agent  
*Rickettsia prowazekii*  
*Rickettsia rickettsii*  
South American haemorrhagic fever viruses:  
Junin  
Machupo  
Sabia  
Flexal  
Guanarito  
Tick-borne encephalitis complex (flavi) viruses:  
Central European tick-borne encephalitis  
*mycoides capri*  
Far Eastern tick-borne encephalitis  
Russian spring and summer encephalitis  
Kyasanur forest disease  
Omsk hemorrhagic fever  
Variola major virus (Smallpox virus)  
Variola minor virus (Alastrim)  
*Yersinia pestis*  
Abrin  
Conotoxins  
Diacetoxyscirpenol  
Ricin  
Saxitoxin  
Shiga-like ribosome inactivating proteins  
Tetrodotoxin

**High Consequence Livestock Pathogens and Toxins/Select Agents (Overlap Agents)**

*Bacillus anthracis*

**USDA High Consequence Livestock and Toxins (Non-Overlap Agents and**

Akabane virus  
African swine fever virus  
African horse sickness virus  
Avian influenza virus (highly  
Blue tongue virus (Exotic)  
Bovine spongiform encephalopathy  
Camel pox virus  
Classical swine fever virus  
*Cowdria ruminantium* (Heartwater)  
Foot and mouth disease virus  
Goat pox virus  
Lumpy skin disease virus  
Japanese encephalitis virus  
Malignant catarrhal fever virus (Exotic)  
Menangle virus  
*Mycoplasma capricolum*/M.F38/M.  
*Mycoplasma mycoides mycoides*  
Newcastle disease virus (VVND)  
Peste Des Petits Ruminants virus  
Rinderpest virus  
Sheep pox virus  
Swine vesicular disease virus  
Vesicular stomatitis virus (Exotic)

**Listed Plant Pathogens**

*Liberobacter africanus*  
*Liberobacter asiaticus*  
*Peronosclerospora phillippinensis*  
*Phakopsora pachyrhizi*  
Plum Pox Potyvirus  
*Ralstonia solanacearum* race 3, biovar 2  
*Sclerophthora rayssiae* var *zeae*  
*Synchytrium endobioticum*  
*Xanthomonas oryzae*

BUMC  
Biosafety Manual  
Revised Document  
October 12, 2007

*Brucella abortus*  
chlorosis strain)  
*Brucella melitensis*  
*Brucella suis*  
*Burkholderia mallei* (formerly *Pseudomonas mallei*)  
*Burkholderia pseudomallei* (formerly *Pseudomonas pseudomallei*)  
Botulinum neurotoxin producing species of *Clostridium*  
*Coccidioides immitis*  
*Coxiella burnetii*  
Eastern equine encephalitis virus  
Hendra virus  
*Francisella tularensis*  
Nipah virus  
Rift Valley fever virus  
Venezuelan equine encephalitis virus  
Botulinum neurotoxin  
*Clostridium perfringens* epsilon toxin  
Shigatoxin  
Staphylococcal enterotoxin  
T-2 toxin

*Xylella fastidiosa* (citrus variegated)

## Chapter 11

### Transportation of Biological Materials

The packaging and transportation of biological materials are subject to strict local, state, federal, and international regulations. This is particularly so if the material is transported through the “public domain,” namely, those roadways, airways, and sea lanes accessible to the public.

Therefore, at BU/BMC, unless the material is being moved within a specific campus, legal requirements governing packaging, labeling, and handling must be followed.

The intent of the packaging and transportation regulations is to prevent accidental exposure of personnel who may handle the material during its shipment. Therefore, certain general criteria apply to all possible transportation scenarios.

Prior to transporting any biological materials, the following controls must be in place:

- Emergency procedures (e.g., contact names and information, spill clean up, disinfection protocols, etc.) must be known to the person carrying the materials.
- Container must be appropriate for the material being transported.
- Material must be packed so that it will stay upright during transportation.
- The containers must be properly labeled.
- Proper protective clothing must be worn during the packaging of the material.
- Hands should be washed after handling materials.
- Open cuts or other wounds should be covered before handling the materials.
- Aerosol generation must be avoided when handling and packing the materials.
- The person packaging the material must ensure that the exterior surfaces of each package are free of any potential contamination by the packed material.

#### Transportation within a Campus

The following requirements must be observed during the transportation of biological materials within a campus (e.g., between two laboratories):

- At a minimum, all laboratory materials must be transported in a secondary container that is gasket-sealed, shatterproof, and leak-proof. Materials should never be carried in hands or pockets.
- The secondary container should be closeable and easy to decontaminate; an absorbent pad (or similar material) should be placed inside the secondary container to absorb any spills.
- A laboratory coat should be worn during transport.
- Label information must include the identity of the biological material or agent, the universal biohazard symbol (if the material or agent is in, or above, Risk Group 2), and the sending and receiving laboratory identification (e.g., PI name and room number).
- Each individual container must have enough label information to identify its contents. Other information should be on the outside of the package.
- The container should be carried directly to the intended laboratory and not taken to offices, cafeterias,

- or other public or inappropriate locations.
- Upon delivery, the receiving laboratory personnel should be informed and the material properly stored.
- The package should be carefully inspected for signs of leakage or other contamination and, if necessary, decontaminated before opening.

### **Transportation between Campuses**

Transportation of biological samples between campuses (i.e., BUMC and CRC) is subject to the general conditions described above. In addition, because the transportation takes place through the public domain, the following other conditions apply:

- All biological samples must be packed according to Department of Transportation/International Air Transport Association (IATA) regulations; this includes triple-packaging all samples, even if exempt materials.
- The specimen should be placed inside a primary container with a tight-fitting, leak-resistant top (e.g., full round-threaded screw cap with seal or stopper).
- The primary container is placed within a secondary (outermost) container that must meet the following specifications:
  - Shatter- and leak-resistant.
  - Surfaces can be easily cleaned.
  - Enough extra space to hold coolant and/or absorbent materials.
  - Labeled with the universal biohazard symbol if material(s) or agent(s) is in or above Risk Group 2.
- Label information must include the identity of the biological material or agent, the universal biohazard symbol (if the material or agent is in or above Risk Group 2), and the sending and receiving laboratory identification (e.g., PI name and room number).
- Each individual container must have enough label information to identify its contents. Other information should be on the outside of the package.
- Transfer may be either by a courier or a responsible, trained laboratory employee.
- The BU shuttle system must not be used for transportation of infectious agents or other biohazardous materials.
- The container should be carried directly to the intended laboratory and not taken to offices, cafeterias, or other public or inappropriate locations.
- Upon delivery, the receiving laboratory personnel should be informed and the material properly stored. The package should be carefully inspected for signs of leakage or other contamination and, if necessary, decontaminated before opening.

### **Packaging and Shipping Infectious Agents via Domestic Flights**

Occasions do arise when a PI must either ship or receive biological materials from another institution. Such activities are governed by strict federal and international guidelines.

The International Civil Aviation Organization (ICAO) is the United Nations entity that governs all international civil aviation matters. The ICAO's *Technical Instructions for the Safe Transport of Dangerous Goods by Air* govern the shipping of dangerous goods. These technical instructions have been incorporated into U.S. law and are an acceptable method of transport in the United States (49 CFR 171.11).

Packaging and shipping biological materials involves certain risks with numerous potential liabilities. The International Air Transport Association's (IATA) *Dangerous Goods Regulations* (DGR), latest edition, is the worldwide gold standard for shipping. The IATA regulations apply to *all* air transport, both domestic and international flights. Following IATA's DGR ensures that a package will also meet U.S. Department of Transportation requirements for ground transport.

**All responsibilities for packaging and shipment of these agents have been assigned to the shipper.** Only properly trained personnel may offer infectious materials for transport. The following is only a summary of the requirements for packaging and shipping infectious agents and **does not** constitute proper training.

### *Definitions and Applicability*

- *Dangerous goods*: articles or substances capable of posing significant risk to health, safety, property, or the environment when transported by surface or air. Most infectious or biological materials are considered dangerous goods and therefore subject to shipping regulation.

- *Infectious substances*: substances known or reasonably expected to contain pathogens. Pathogens are defined as micro-organisms (including bacteria, viruses, rickettsiae, parasites, fungi) and other agents, such as prions, which can cause disease in humans or animals.

For the purposes of shipping classification, infectious substances are broken into two categories:

- **Category A**: an infectious substance transported in a form that, when exposure to it occurs, is capable of causing permanent disability or life-threatening or fatal disease in otherwise healthy humans or animals.
  - **Category B**: an infectious substance that does not meet the criteria for inclusion in Category A.
- *Biological products*: those products derived from living organisms manufactured and distributed in accordance with the requirements of national governmental authorities (e.g., the FDA). They may have special licensing requirements and are used either for prevention, treatment, or diagnosis of disease in humans or animals, or for developmental, experimental, or investigational purposes related thereto.

Biological products manufactured and packaged in accordance with the requirements of appropriate national authorities; transported for the purposes of final packaging or distribution; and for personal health-care use by medical professionals are NOT subject to dangerous goods regulation. However, biological products not governed by national authorities and that are known or reasonably believed to contain infectious substances MUST be classified and shipped according to dangerous goods regulations.



- *Exempt Patient Specimens*: patient specimens for which there is a minimal likelihood that pathogens are present are exempt from most of the shipping regulations. However, they must be marked with the words “exempt human specimen” or “exempt animal specimen” and must be triple-packed as described below.
- *Completely Exempt Substances*: materials that are totally exempt for consideration under the shipping regulations:
  - Substances containing micro-organisms that are non-pathogenic to humans or animals
  - Substances in a form so that any present pathogens have been neutralized or inactivated such that they no longer pose a health risk
  - Environmental samples (including food and water samples) that are not considered to pose a significant risk of infection, and
  - Dried blood spots, faecal occult blood screening tests, blood or blood products intended for transfusion, and tissues or organs intended for transplantation.

### **Classification and Identification**

The substance to be shipped must be classified as completely exempt from regulation, an exempt patient specimen, or a Category A or B infectious substance. Once classified, proper shipping names and identification numbers can then be assigned to the material. Exempt patient specimens do not require shipping names and identification numbers. However, Category A and B materials are assigned the following names and numbers:

- **Category A**: assign one of two identifiers, depending on whether or the material infects humans:
  - Infectious substance affecting humans: UN 2814
  - Infectious substance affecting animals: UN 2900

*Note: If a material infects both humans and animals, use the Infectious substance affecting human code, UN 2814.*
- **Category B**: biological substance category B: UN 3373

### **Packaging**

All regulated infectious substances, including Category A, Category B, and exempt patient specimens, must be triple packed:

- The innermost primary receptacle(s) is leak-proof.
- A leak-proof secondary receptacle with absorbent material placed between the primary and secondary receptacles to prevent the release of liquid during transport and to shield multiple primary receptacles from coming in contact with one another.
- Rigid, tertiary outer packaging that is at least 100 mm (4 in) in its smallest external dimension.

Additionally, shipments of Category A and Category B materials must be packaged according to IATA Packing Instructions 602 and 650, respectively. Those guidelines require the following:

- Shipments must be prepared in such a way that they arrive at their destination in good condition and present no hazard to persons or animals during shipment.
- Outer packaging must meet structural strength requirements and carry defined specification markings.
- Packages must be at least 100 mm (4 in) in their smallest external dimension.
- An itemized list of contents must be enclosed between the secondary container(s) and the outer packaging.
- All packages containing infectious substances must be marked durably and legibly on the outside of the package with the name and telephone number of a person responsible for the shipment.
- The shipper must make advance arrangements with the recipient and the operator to ensure the shipment can be transported and delivered without unnecessary delay.
- Substances shipped at ambient temperatures or higher must be in primary receptacles made only of glass, metal or plastic, with a positive means of ensuring a leak-proof seal. Screw caps must be reinforced with adhesive tape.
- Substances shipped refrigerated or frozen must carry the refrigerant outside the secondary container. If wet ice is used, the packaging must be leak-proof. If dry ice is used, the packaging must permit the release of CO<sub>2</sub> gas.
- Primary and secondary containers must retain their integrity across the full range of pressures and temperatures experienced under normal and loss-of-refrigerant conditions.

## **Labeling**

Package labeling is in the form of standardized pictures that must be affixed to the outside. The color and design of each label is prescribed in the IATA regulations. All labels must be at least 2 inches on the smallest side.

For the purposes of infectious substances, five different labels must be considered:

### Category A:



### Category B:





## Training Requirements

Those involved in the packaging and shipping of diagnostic specimens or infectious substances must undergo training every two years or when activities change. It is the department's responsibility to ensure training is completed. The OEHS and Biosafety Office can provide this training. The shipper is obligated to receive further qualification when shipping hazardous materials of a class or division where current training is insufficient.

## Shipping Documents

Shipping papers describing the material in transit must accompany all shipments of dangerous goods. For ground transport, a Bill of Lading is required. For air transport, an Airway Bill takes the place of a Bill of Lading. However, air transport of a Category A material also requires that a Shipper's Declaration of Dangerous Goods be filled out. The full and accurate completion of the Shipper's Declaration is essential, as these are legal documents signed by the shipper, which creates a contract between the shipper and the carrier. The document must be accurate, legible, and neat and without any spelling errors.

- The declaration form must be completed in English.
- Three copies of the declaration must be completed. One copy will remain with the shipper (PI). Two copies will be sent with the shipment. If the declaration is not a three-part NCR form, photocopies must be made.

S	INSTRUCTIONS
1	<b>Shipper's:</b> <ul style="list-style-type: none"> <li>◆ Name</li> <li>◆ Address</li> <li>◆ Phone number</li> </ul>
2	<b>Receiver's:</b> <ul style="list-style-type: none"> <li>◆ Name</li> <li>◆ Address</li> <li>◆ Phone number</li> </ul>
3	<b>Line out the item that does <u>not</u> apply.</b> Passenger aircraft can only be used to ship quantities less than 50 ml. Cargo aircraft must be used to ship quantities between 50 ml and 4 L.
4	<b>Line out the item that does <u>not</u> apply.</b>
5	<ul style="list-style-type: none"> <li>◆ Proper Shipping Name (infectious substance, affecting humans or infectious substance, affecting animals)</li> <li>◆ Identify the specimen by name in parenthesis  <i>ex. Infectious substance, affecting humans (rabies virus)</i></li> </ul>

6	<b>Class or Division</b> * Always 6.2
7	<b>UN Code</b> * UN 2814 or UN 2900 (UN 3373 does not require shippers dec.)
8	<b>Packaging Group</b> * There is no packaging group for biological agents.
9	<ul style="list-style-type: none"> <li>◆ Identify by stating the number of containers by the quantity in each container. (e.g., 5 X 10ml)</li> <li>◆ Identify type of outer container for the shipment</li> </ul>
10	<b>Packaging Instructions</b> * 602 or 650 (also 904 if dry ice included)
11	<ul style="list-style-type: none"> <li>◆ 24-hour emergency contact number for the shipper (PI, Lab Supervisor),</li> <li>◆ The statements, “Prior arrangements as required by the IATA Dangerous Goods Regulations 1.3.3.1 have been made.” And “Prepared according to ICAO/IATA.”</li> </ul>
12	<b>Name and Signature of the shipper.</b>

\* As described in the latest edition of the IATA Dangerous Goods Regulations

**Note:**

- *When shipping biomaterials on dry ice, remember that dry ice is itself considered a dangerous good and must also be listed on the shipping documents as UN1845, Packing Group III, Packing Instruction 904.*
- *BU/BMC have adopted additional shipping requirements for “high hazard materials” with strict requirements for approved carriers, including a dedicated vehicle, point-to-point delivery, and specified shipping routes. For more information, contact OEHS.*
- *The transportation must also meet the NIH guidelines.*

**BU/BMC Materials Transportation Mitigation Policy**

**Purpose and Applicability**

- The purpose of this policy is to define the procedures used to manage the shipping, receiving, and transportation of items determined to be subject materials by the Office of Environmental Health and Safety in accordance with Boston University Medical Center (BU/BMC) policies and procedures and all applicable laws and regulations.
- This policy applies to all items determined to be high risk and to all employees and staff, including those who are visiting users of BU/BMC facilities and those who are contracted services involved in the shipping, receiving, handling or other use of subject materials as described below.
- This policy defines the protocols for the selection of contracted services to be used in the shipping, receiving, and transport of subject materials. It also includes standards for packaging, transporting, delivery routes, and the quality controls to be utilized to ensure that these standards are adhered to by all those involved in the management of subject materials transport.

## Definitions

- **Subject Materials:** a substance or material in a quantity and form that may pose a high level of risk to health, safety, or property when received, transported, and/or stored. These materials include, but are not limited to, toxic/infectious substances (including select agents); radioactive materials; chemicals; compressed gases; and any other materials that BU/BMC OEHS deems should be managed throughout its transport.
- **Select Agents:** biological agents and toxins that have the potential to pose a threat to public health and safety if used for bioterrorism purposes. The list includes more than 70 bacteria, viruses, toxins, rickettsia, and fungi, and the program is regulated by the Department of Health and Human Services (DHHS) and Department of Agriculture (USDA) under the Federal Regulation for Select Agents [42 CFR 73.0; 7 CFR 331; 9 CFR 121].
- **Shipper:** the shipper is the person who packages the subject material and signs the shipper's declaration form. This person is responsible for the material to be classified, identified, packaged, marked, and labeled, with all appropriate documentation included with the package.
- **Transporter:** the transporter is the individual, operator, or contracted service who obtains the package from the shipper, verifies it has been packaged correctly, and carries the package to the receiver.
- **Receiver:** the receiver, for the purposes of this policy, is the individual who receives the package. This individual is required to have shipping training and notify the shipper upon receipt of the planned delivery of subject material.
- **Shipper's Declaration Form:** the documentation that a subject material will be shipped. These documents will be maintained in accordance with all laws, regulations, and BU/BMC policies, including standards for the maintenance of original forms by the shipper, transporter, and receiver.

## Roles and Responsibilities

- **Office of Environmental Health and Safety (OEHS)** is responsible for the management and oversight of the Materials Transportation Mitigation Policy and for ensuring compliance with the procedures outlined within this policy by all employees and staff, visiting users of BU/BMC facilities, and contracted services, including associated transporters.
- **Office of General Services (OGS)**, through its Security Investigations Unit, will initiate, conduct, and/or participate in audits and conduct investigations as necessary. OGS, through its Systems and Operations units, will be responsible for maintaining the security of locations determined to be appropriate for the receiving, shipping, and storage of designated materials, as well as the screening and examination of vehicles, packages, and personnel.
- **Office of Mail Services** will provide support to OEHS and OGS with the screening/examination of delivered packages, the staffing of designated locations, and the management of contracted services.

- **Office of Purchasing Services** will be responsible for facilitating the selection of contracted service providers who are capable of providing services in accordance with this policy and in compliance with all applicable laws and regulations. The Office of Purchasing Services will select, monitor, manage, and discharge all contracted services who are involved in the management and transport of subject materials.
- **Manager of Emergency Planning and Response (MEPR)** will provide recommendations related to emergency management planning, training, and response coordination to OEHS, Facilities Management and Planning, the Department of Public Safety, and members of the Emergency Response Team. In addition, the MEPR will participate in the development and implementation of emergency response plans, exercises, risk reduction initiatives, and risk prevention measures. The MEPR will also serve as the liaison to the Boston Mayor's Office of Emergency Preparedness and the Massachusetts and federal emergency management agencies.
- **Shipper** will be responsible for ensuring that the material being shipped is appropriately packaged, including classifying, identifying, marking, labeling, and providing appropriate documentation with the package. The shipper must be trained in accordance with all applicable laws, regulations, and BU/BMC policies, including those that address the type and frequency of training and necessity of additional training should laws, regulations, or BU/BMC policies change at any time.
- **Transporter** will be required to do the following: to accept, store, load, inspect, and deliver packages to an approved location using approved access routes; report any and all violations of law, regulation, or policy; retain all records; and have proper shipping training. The inspection of packages includes requirements involving damage to packages, reporting guidelines, and immediate communication to the shipper and receiver, as well as to public health and regulatory authorities. In addition to these requirements, transport companies may have their own specific safety requirements for subject material transport.

## Procedures

- **OEHS** and **OGS** will determine the best location for the receipt, control, audit, transport, and shipping of all items under this policy. Such location(s) will be operated or provided with oversight by representatives of OEHS and other related user departments. These areas will be routinely audited. Transport to and from this location will be by major routes of travel that immediately border BU/BMC and are limited to Albany Street, Massachusetts Avenue, and the highway/connector system in the rear of BioSquare.
- **OEHS** will train all users about the laws, regulations, policies, and requirements involved in the shipping and receiving of subject materials and will manage the tightly controlled, pre-approved scheduling of shipment and delivery times. OEHS will train all users in the approved procedures for the packaging of materials, the approved contracted services to be used in the transport of such materials, and the penalties of failing to follow all aspects of this policy.

- **OEHS** and **OGS** will ensure that all staff involved in the subject material's shipping/receiving areas undergo a background clearance check, as appropriate and consistent with the select agent law requirements prior to being approved to work in these locations.

- **Packaging standards** will be determined by the appropriate regulatory authorities with all specified package integrity testing complete. These mandated packaging requirements will only be altered in the event that BU/BMC determines a need to exceed the standard and will only be altered with the approval of all relevant regulatory authorities.

- **Transport of select agents** will be done in accordance with all laws and regulations, including the immediate notification of DHHS and CDC prior to being sent and within 24 hours of receipt. The transport will also include the utilization of appropriate forms and the reporting of registration numbers of all parties involved in shipping, transporting, and receiving packages.

- **OEHS, OGS** and the **Office of Purchasing** will select contractors for the transportation of subject materials based on criteria including, but not limited to, the following:

- Past performance on similar contracts.
- Ability to provide services as a single-source provider for transport of all subject materials.
- Ability to provide transport services in accordance with all regulatory standards.
- Ability to provide transport services in accordance with all BU/BMC standards.
- Ability to provide staffing that has undergone, and continues to undergo on an annual basis, appropriate background checks.
- Ability to provide courier services that may require that a single individual pick up and deliver packages.
- Ability to provide GPS tracking of packages or vehicles as determined appropriate.
- Ability to provide customized services that require adherence to BU/BMC determined routes of travel, audit procedures, and strictly defined schedules for both pick-ups and deliveries.
- Ability to provide an all-inclusive chain of custody document upon delivery of each package.
- Ability to provide resources to participate in BU/BMC audits of services.

- **OEHS** will schedule all deliveries and will track the delivery with the contracted service performing the transportation by means of contractor-provided tracking methods. BU/BMC will initiate its own tracking methods at its discretion and will determine the type of packaging that the shipper, receiver, and transportation company uses, and that it is in compliance with all laws and regulations.

- **OEHS** will schedule all deliveries to arrive during normal working hours. Normal working hours are defined here as between the hours of 8:00 a.m. and 6:00 p.m.

- **Failure to receive** a package within the specified time range of delivery will result in an immediate investigation involving the transport contractor, the shipper, BU/BMC, and all applicable regulatory personnel.



- ***Packages delivered to BU/BMC*** will be inspected, verified, documented, and transported to the appropriate location within BU/BMC by OEHS. In the event of any signs of damaged packaging the criteria described in Page 66 must be followed.
- ***The transporter will contact*** the relevant State Police department having jurisdiction for any problem or incident that may occur during transit of subject material in their state.

### Key References and Resources

U.S. Department of Transportation, 49 CFR Part 171 final rule, 03/18/05  
International Air Transport Authority 2006, 46<sup>th</sup> edition, *Dangerous Goods Regulations*  
U.S. Public Health Service (HHS)/ CDC 42 CFR Part 73.0, "Possession, Use & Transfer of Select Agents and Toxins," 03/18/05  
*Morbidity and Mortality Weekly Report*, Vol. 1, No. RR-19, "Laboratory Security and Emergency Response Guidance for Laboratories Working with Select Agents," 12/06/02

### Websites

BU/BMC, Office of Environmental Health and Safety (OEHS): [www.bumc.bu.edu/ehs](http://www.bumc.bu.edu/ehs)  
BU/BMC, Office of General Services: [www.bumc.bu.edu/gs](http://www.bumc.bu.edu/gs)  
BU/BMC, Purchasing: [www.bu.edu/purchasing](http://www.bu.edu/purchasing)  
U.S. Department of Transportation: [www.dot.gov](http://www.dot.gov)  
MA Department of Public Health State Lab Institute: [www.mass.gov/dph/bls/lasite.htm](http://www.mass.gov/dph/bls/lasite.htm)  
International Air Transport Authority: [www.iata.org](http://www.iata.org)  
United Parcel Service, Hazardous Materials Support Center: [www.ups.com](http://www.ups.com)  
The Centers for Disease Control and Prevention: [www.cdc.gov](http://www.cdc.gov)  
CDC Select Agent Program, Laboratory Registration: [www.cdc.gov/od/sap](http://www.cdc.gov/od/sap)  
United States Postal Service: [www.usps.gov](http://www.usps.gov)  
Federal Express, Dangerous Goods Program: [www.fedex.com](http://www.fedex.com)  
United States Public Health Service: <http://www.hhs.gov/>  
USDA Select Agent Program: [http://www.aphis.usda.gov/programs/ag\\_selectagent/index.html](http://www.aphis.usda.gov/programs/ag_selectagent/index.html)

BUMC  
Biosafety Manual  
Revised Document  
October 12, 2007

## **Appendix A**

### **IBC Application Forms**

IBC Application Forms can be found at <http://www.bumc.bu.edu/ibc>

## Appendix B

### Importation and Exportation of Etiologic Agents

Multidisciplinary and multi-institutional research is a common practice that involves collaboration among faculty from various institutions and countries. At times it is necessary to share biological samples or materials with collaborators. Federal regulations strictly control the importation and exportation of etiologic agents. The following outlines two major requirements that must be followed.

***Note: All importation and exportation of etiologic agents must be processed through the Biosafety Program.***

#### CDC Etiologic Agent Import Permit Program

Etiologic agents are those microorganisms and microbial toxins that cause disease in humans and include bacteria, bacterial toxins, viruses, fungi, rickettsiae, protozoans, and parasites. These disease-causing microorganisms may also be referred to as infectious agents. Arthropods and other organisms that transmit pathogens to animals (including humans) are called vectors.

Etiologic agents, vectors, and materials containing etiologic agents are recognized as hazardous materials. Materials containing etiologic agents are regularly transported from one location to another by common land and air carriers. Materials containing etiologic agents must be appropriately packaged to prevent breakage or leakage in order to avoid exposing the package contents to package handlers, transporters, and the general public. Materials containing etiologic agents must be packaged, labeled, and transported in accordance with all applicable regulations. Material containing etiologic agents being imported into the United States must be accompanied by a U.S. Public Health Service importation permit.

#### • ***Importation Permits***

Importation permits are issued only to the importer, who must be located in the United States. The importation permit, with the proper packaging and labeling, will expedite clearance of the package of infectious materials through the U.S. Public Health Service Division of Quarantine and release by U.S. Customs.

The importer is legally responsible for ensuring that the foreign personnel package, label, and ship the infectious materials according to federal and international regulations. Shipping labels with the universal biohazard symbol, the importer's address, the permit number, and the expiration date are also issued to the importer with the permit. The importer must send the labels and one or more copies of the permit to the shipper. The permit and labels inform the U.S. Customs Service and U.S. Division of Quarantine personnel of the package contents.

#### ***Federal Regulation***

The importation of etiologic agents is governed by the following federal regulation: USPHS 42 CFR - Part 71 Foreign Quarantine. Part 71.54 Etiologic agents, hosts, and vectors.

- A person may not import into the United States, nor distribute after importation, any etiologic agent or any arthropod or other animal host or vector of human disease, or any exotic living arthropod or other animal capable of being a host or vector of human disease unless accompanied by a permit issued by the Director.
- Any import coming within the provisions of this section will not be released from custody prior to receipt by the District Director of U.S. Customs Service of a permit issued by the Director (Centers for Disease Control and Prevention).

#### *Items Requiring Permits*

##### • **Etiologic agents**

It is impractical to list all etiologic agents on this website. In general, an import permit is needed for any infectious agent known or suspected to cause disease in humans.

##### • **Biological materials**

Unsterilized specimens of human and animal tissues (such as blood, body discharges, fluids, excretions, or similar material) containing an infectious or etiologic agent require a permit in order to be imported.

##### • **Hosts and vectors**

- *Animals*: any animal known or suspected of being infected with an organism capable of causing disease in humans may require a permit issued by CDC. Importation of live turtles of less than 4 inches in shell length and live nonhuman primates is regulated by the CDC's Division of Global Migration and Quarantine (<http://www.cdc.gov/ncidod/dq/>).
- *Bats*: all live bats require an import permit from the CDC and the U.S. Department of Interior, Fish and Wildlife Services. The application for a CDC import permit for live exotic bats is at CDC Importation of Animals website (<http://www.cdc.gov/ncidod/dq/>).
- *Arthropods*: any living insect or other arthropod that is known or suspected of containing an etiologic agent (human pathogen) requires a CDC import permit.
- *Snails*: snail species capable of transmitting a human pathogen require a CDC permit.

#### *Packaging Requirements*

Infectious materials imported into this country must be packaged to withstand breakage and leakage of contents and be labeled, as specified in the following federal regulations:

- USPHS 42 CFR Part 72 - Interstate Shipment of Etiologic Agents
- DOT 49 CFR PART 173 - Transportation of Etiologic Agents
- For international shipments, the International Air Transport Association's (IATA) *Dangerous Goods Regulations* should be consulted.

#### *Other Permits*

- USDA and APHIS permits are required for infectious agents of livestock and biological materials containing animal material. Tissue culture materials and suspensions of cell culture-grown viruses or other etiologic agents containing growth stimulants of bovine or other livestock origins are controlled by the USDA because of the potential risk of introduction of exotic animal diseases into the United States. For more information, contact USDA/APHIS at their website, [http://www.aphis.usda.gov/animal\\_health/](http://www.aphis.usda.gov/animal_health/).
- U.S. Fish and Wildlife Service permits are required for certain live animals, including bats. For more

information, call (800) 344-WILD or visit their website, <http://www.fws.gov/>.

- Individuals wishing to import select agents and toxins must be registered with the CDC's Select Agent Program in accordance with 42 CFR Part 73 (Possession, Use, and Transfer of Select Agents and Toxins; Interim Final Rule) for the select agent(s) and toxin(s) listed on the import permit application. Also, in accordance with 42 CFR Part 73.16(a), an APHIS/CDC Form 2 must be completed and submitted to the CDC Select Agent Program and granted approval prior to the shipment of the select agents or toxins under the import permit. Additional information can be found at <http://www.cdc.gov/od/sap>.

### **Exportation of Infectious Materials**

The export of a wide variety of etiologic agents of human, plant, and animal diseases may require a license from the Department of Commerce. To determine if a license is necessary, visit <http://www.bis.doc.gov/Licensing/>.

Export control regulations are rather complex and may have multi-agency jurisdictions that must approve activities. The Department of Commerce regulations state that:

“Activities subject to the Export Administration Regulations (EAR) may also be controlled under export-related programs administered by other agencies. Items and activities subject to the EAR are not necessarily exempted from the control programs of other agencies.”

Please contact the Biosafety Program as soon as possible if you intend to export any biological materials.

## Appendix C

### Laboratory Ventilation and Containment for Biosafety

Laboratory-ventilated containment equipment fall into three major categories:

#### Laboratory Chemical (“Fume”) Hoods

Traditional laboratory chemical (or fume) hoods are designed to capture and control chemical vapors and pull them away from the worker. Although the inward flow of air protects the user, chemical hoods do not protect the product (the desired organism being manipulated).

Unless a High Efficiency Particulate Air (HEPA) filter is added, chemical hoods do not provide protection against release of viable organisms to the environment. The airflow within a chemical hood is often somewhat turbulent, which can potentially result in exposure of the user to the organisms being used. In short, a chemical hood is *not* a biological safety cabinet and generally does not provide product protection or environmental protection.

#### Horizontal Laminar Flow Clean Bench

With horizontal laminar flow clean benches, HEPA-filtered air flows horizontally across the workspace directly toward the user. These clean benches provide product protection and were originally designed to provide a particulate-free environment for the manufacture of semiconductor components.

Clean benches provide product protection against microbial contamination, but they *do not* provide personal or environmental protection. In fact, the horizontal flow of air will blow biological agents directly toward the user and into the laboratory. Clean benches are not a biological safety cabinet, and they should not be used with any materials (biological, chemical, or radiological) requiring containment for protection of personnel or the environment.

Clean benches are acceptable for tissue culture work only with cell lines considered to represent low risk (BSL-1 agents) to laboratory workers (including immunocompromised individuals who may frequent the lab). Human cell lines and nonhuman primate cell lines are generally considered to be BSL-2 agents and would not be suitable for use in a clean bench.

#### Biological Safety Cabinets

Biological safety cabinets (BSCs) are divided into Class I, II, and III (see schematic below). Class II BSCs are subdivided into type A and type B. All BSCs provide personnel and environmental protection, with Class II BSCs also providing product protection.

- Personnel protection is achieved by inward airflow through the front of the cabinet.
- Product protection is achieved by downward HEPA-filtered airflow from the top of the cabinet.
- Environmental protection is achieved by HEPA filtration of exhaust air.

New NSF Classification, Adopted 2002	Previous NSF Classification	General Description
A1	Class II, Type A	<ul style="list-style-type: none"> <li>• 70% air recirculated; 30% exhausted from a common plenum to the room;</li> <li>• 75FPM intake;</li> <li>• may have biologically contaminated positive pressure plenum</li> </ul>
A2	Class II, Type A/B3	<ul style="list-style-type: none"> <li>• 70% air recirculated; 30% exhausted from a common plenum to the room;</li> <li>• 100FPM intake;</li> <li>• biologically contaminated plenum under negative pressure or surrounded by negative pressure</li> </ul>
A2	Class II, Type B3	<ul style="list-style-type: none"> <li>• 70% air recirculated; 30% exhausted from a common plenum to a facility exhaust system;</li> <li>▪ 100FPM intake;</li> <li>▪ biologically contaminated plenum under negative pressure or surrounded by negative pressure</li> </ul>
B1	Class II, Type B1	<ul style="list-style-type: none"> <li>▪ 40% air recirculated; 60% exhausted from cabinet;</li> <li>▪ exhaust air pulled through dedicated exhaust duct into facility exhaust system;</li> <li>▪ 100FPM intake</li> <li>▪ all biologically contaminated plenums are negative to the room or surrounded by negative pressure</li> </ul>

		plenums
B2	Class II, Type B2	<ul style="list-style-type: none"> <li>▪ 0% air recirculated; 100% exhausted from cabinet</li> <li>▪ exhaust air pulled through dedicated exhaust duct into facility exhaust system;</li> <li>▪ 100FPM intake</li> <li>▪ all ducts and plenums are under negative pressure</li> <li>▪ all contaminated ducts are under negative pressure or surrounded by directly exhausted negative pressure ducts or plenums</li> </ul>

• **Certification of BSCs**

Generally, commercial BSCs are tested by the cabinet manufacturer in accordance with National Sanitation Foundation (NSF) criteria. Cabinets that meet the NSF criteria for performance characteristics, including biological containment, ventilation, cabinet leakage, and HEPA filter leakage, are NSF certified.

Field certification of BSCs is also required to ensure that the cabinet still performs as it did when it obtained NSF certification at the factory. NIH requires field certification under the following circumstances: (1) upon installation of a new BSC; (2) annually thereafter; (3) after repair or maintenance is performed; and (4) after the BSC is relocated.

NSF standard 49 provides criteria for construction of BSCs, testing by manufacturers (including biological containment testing), and field certification. NSF has also established a certification program for field certifiers to ensure a minimum level of competency and professionalism. It is recommended that NSF field certifiers be used for field certification of BSCs. Field certification tests include:

• **Primary tests (BSC performance):**

- a. Inflow test
- b. Down-flow test
- c. Smoke pattern test
- d. HEPA filter leakage
- e. Cabinet leakage (when BSC is newly installed, relocated, or maintenance has been performed that involved removal of access panels)

• **Additional tests (worker comfort and safety), performed at discretion of certifier:**



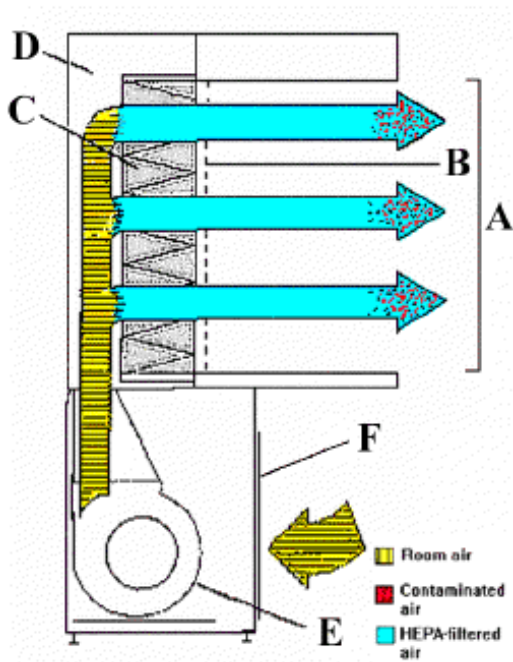

- a. Noise
- b. Vibration
- c. Lighting
- d. Electrical leakage, polarity, and ground circuit resistance

**Horizontal Flow “Clean Bench”**

- A. front opening
- B. supply grille
- C. supply HEPA filter
- D. supply plenum

- E. blower
- F. grille

**Class I BSC**

- A. front opening
- B. sash
- C. exhaust HEPA
- D. exhaust plenum

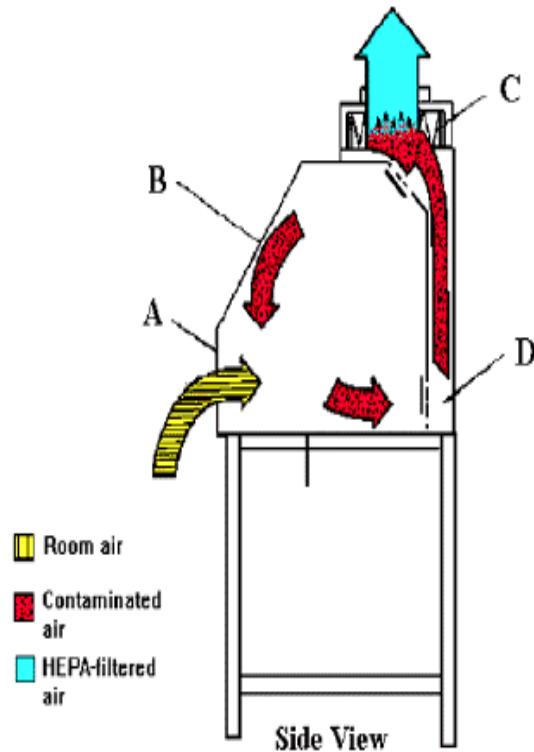

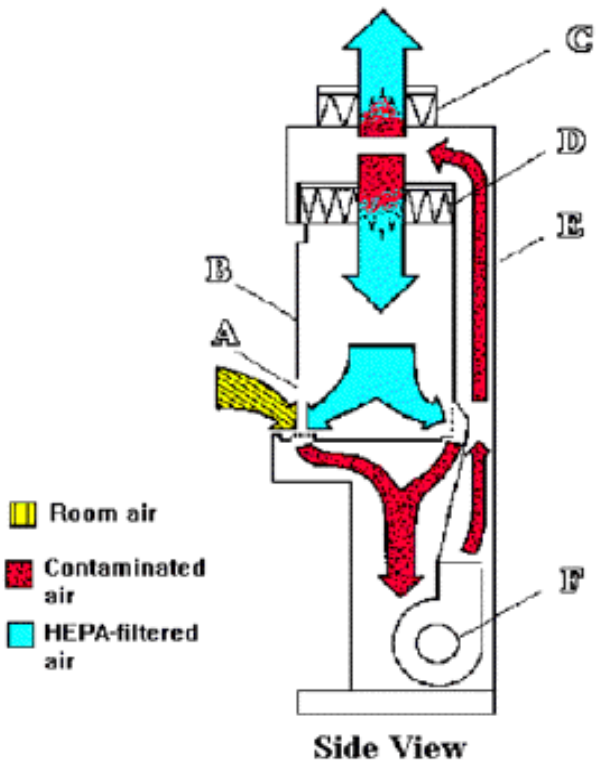

**Class II Type A BSC**

- A. front opening
- B. sash
- C. exhaust HEPA filter
- D. rear plenum
- E. supply HEPA filter
- F. blower

**Class II Type B3 BSC**  
 (Tabletop model)

- A. front opening
- B. sash
- C. exhaust HEPA filter
- D. supply HEPA filter
- E. positive pressure plenum
- F. negative pressure plenum

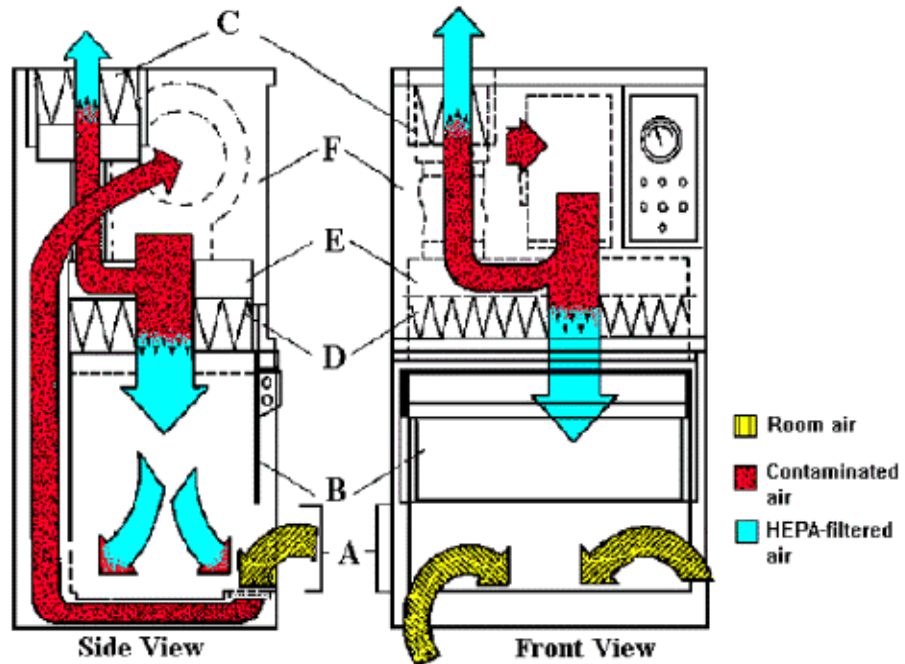

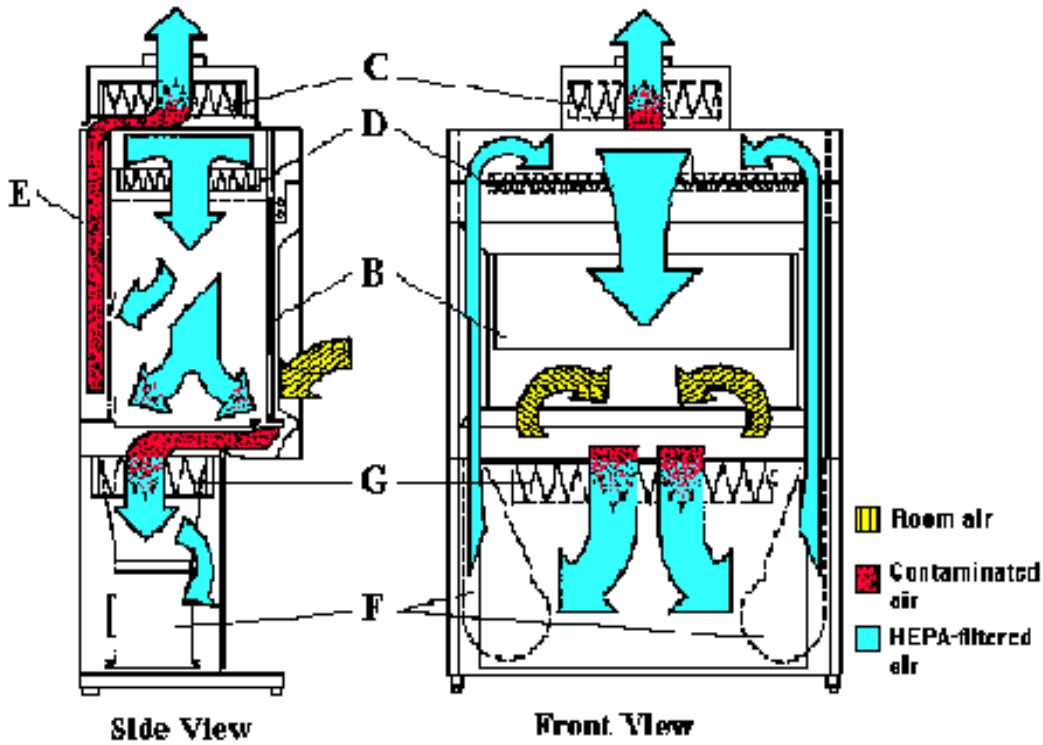

**Class II Type B1 BSC**

- A. front opening
- B. sash
- C. exhaust HEPA filter
- D. supply HEPA filter
- E. negative pressure exhaust plenum
- F. blower
- G. additional HEPA filter for air supply

**Class II Type B2 BSC**

- A. front opening
- B. sash
- C. exhaust HEPA filter
- D. supply HEPA filter

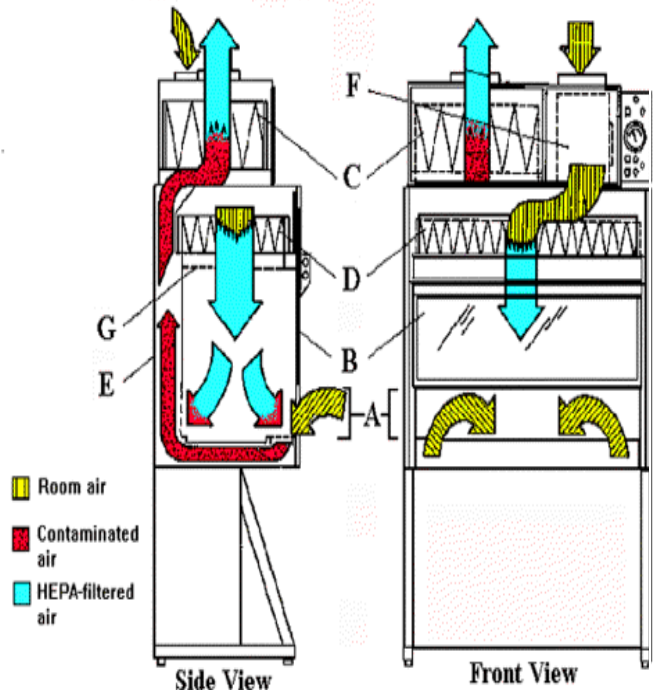

- E. negative pressure exhaust plenum
- F. supply blower
- G. filter screen

## Appendix D

### Autoclave Quality Assurance Program

Autoclaving is an accepted procedure for the decontamination of certain biohazardous waste. Biological cultures and stocks, contaminated solid waste, liquid waste, and small animal carcass waste can be sterilized through autoclaving. After sterilization in a steam autoclave, these materials are considered non-infectious. At BU/BMC, all autoclaved waste is placed into the solid biohazard waste stream. Materials that contain hazardous chemicals or radioisotopes are not to be autoclaved.

To ensure that biohazardous waste is properly decontaminated during autoclaving, the following procedures should be followed by laboratory personnel

1. Infectious waste must be treated in an autoclave for a **minimum of 30 minutes at 121° C (250° F)**; however, the total processing time required to decontaminate infectious waste depends on the specific loading factors (container type, water content, quantity, etc.). A total processing time of 60 minutes is recommended for gravity displacement autoclaves and 10 minutes for vacuum-type autoclaves (132° C).
  - Sterilization by autoclaving is accomplished through exposure and penetration of the contaminated material by superheated steam for an adequate amount of time. Because steam will not penetrate a sealed plastic autoclave bag, bags containing dry loads must not be tightly sealed (rubber band closures will allow bags to “breathe”) or adequate amounts of water must be added to the load. Consult the manufacturer’s instructions for sterilizing materials inside plastic autoclave bags. Liquid waste and fresh animal carcass waste may be autoclaved inside a tightly sealed bag.
2. All autoclaved waste must include a steam sterilization indicator (the use of biohazard bags with a “built-in” indicator is recommended).
3. Steam autoclaves used to treat infectious waste must operate at a minimum temperature of 121° C. The operating temperature of the autoclave must be verified for each run by maintaining a record of the temperature either as a chart or paper tape recording or a manual recording in a logbook.
4. On a monthly basis, confirm that adequate sterilization conditions are being met through the use of ampoules containing heat-resistant spores (*Bacillus stearothermophilus*) placed in the center of an autoclave load. In conjunction with the *B. stearothermophilus* testing, measure and record the maximum temperature achieved during the autoclave cycle through the use of a maximum registering (or “holding”) thermometer.
5. Maintain records of *B. stearothermophilus* testing and maximum autoclave temperature recordings for a minimum of one year (see Autoclave QC Log at end of appendix).

### **Monthly Spore Testing Procedure**

1. Place ampoule of *B. stearothermophilus* spores and holding thermometer in the center of an autoclave load.
2. Process the load under normal operating procedures.
3. The highest temperature indicated on the holding thermometer is entered on the Autoclave QC Log. If this temperature is less than 121° C, the autoclave is not to be used to treat infectious waste until it has been repaired and passes retesting. In the interim, tag the autoclave as “Not Approved for Infectious Waste.”
4. Incubate the autoclaved ampoule and a non-autoclaved, control ampoule according to the manufacturer’s instructions (normally 55°-60° C for 24 to 48 hours).
5. If a color change occurs, the sterilization process was unsuccessful. Discontinue use of the autoclave until it is repaired and passes retesting. Tag the autoclave as “Not Approved for Infectious Waste” until the autoclave passes retesting.
6. Indicate test results on Autoclave QC Log (see end of appendix) and retain for at least one year.

**AUTOCLAVE QC LOG**

Year: \_\_\_\_\_; Autoclave Location: \_\_\_\_\_

Manufacturer: \_\_\_\_\_; Model: \_\_\_\_\_ Serial Number: \_\_\_\_\_

Autoclave Testing Instructions:

1. Perform autoclave QC tests monthly.
2. Place *B. stearothermophilus* spore ampoule and holding thermometer in the center of an autoclave load.
3. Process the load under normal operating procedures.
4. Record the highest temperature indicated on the holding thermometer. If this temperature is less than 121° C, the autoclave is not to be used to treat infectious waste until it has been repaired and passes retesting.
5. Incubate the autoclaved ampoule and a non-autoclaved control ampoule according to the manufacturer's instructions (normally 55°- 60° C for 24 to 48 hours).
6. If a color change occurs, the sterilization process was unsuccessful. Discontinue use of the autoclave (for infectious waste) until it is repaired and passes retesting.
7. Record testing results on Autoclave QC Log and retain for at least one year.

Date	Operator	Cycle Time	Cycle Temp	Results	Comments
Jan.					
Feb.					
Mar.					
Apr.					
May					
June					
July					
Aug.					
Sept.					
Oct.					
Nov.					
Dec.					

## Appendix E

### Biosafety Level 2 (BSL-2) Requirements

Biosafety Level 2 (BSL-2) is suitable for experiments involving agents of moderate potential hazard to personnel and the environment. These organisms are generally not infectious via an aerosol route. Access to the laboratory is limited when experiments are being conducted. Procedures involving large volumes or high concentrations of agents, or in which aerosols are likely to be created, are conducted in biological safety cabinets.

These laboratories have special design and ventilation features and are suitable for experiments involving:

- Microorganisms of low biohazard potential, such as those in Risk Group 2 or BSL-2.
- Recombinant DNA activity requiring BSL-2 physical containment include animal studies that involve the construction of transgenic animals, including human cells.
- Non-recombinant cell and/or tissue culture systems that require this level of containment.
- Oncogenic viral systems classified as low risk.
- Introduction of Risk Group 1 materials into experimental animals.
- Production activities with Risk Group 1 organisms.

The control of potential biohazards at the BSL-2 level is provided by use of standard microbiological practices with the addition of personnel protective equipment (lab coat and gloves).

The following are procedures are used with BSL-2 containment requirements. They are based on the recommendation of the *Biosafety in Microbiological and Biomedical Laboratories* (BMBL) 5<sup>th</sup> Edition, 2007.

#### ***Standard Microbiological Practices***

- Access to the laboratory is limited or restricted at the discretion of the laboratory director when experiments are in progress.
- Persons wash their hands after they handle viable materials, after removing gloves, and before leaving the laboratory.
- Eating, drinking, smoking, handling contact lenses, and applying cosmetics are not permitted in the work areas. Food is stored outside the work area in cabinets or refrigerators designated for this purpose only.
- Mouth pipetting is prohibited; mechanical pipetting devices are used.
- Policies for the safe handling of sharps are instituted.
- All procedures are performed carefully to minimize the creation of splashes or aerosols.
- Work surfaces are decontaminated upon completion of work, or at the end of the day, and after any spill or



splash of viable material with disinfectants that are effective against the agents of concern.

- All cultures, stocks, and other regulated wastes are decontaminated before disposal by an approved decontamination method, such as autoclaving. Materials to be decontaminated outside the immediate laboratory are placed in a durable, leak-proof container and closed for transport from the laboratory. Materials to be decontaminated off-site are packaged in accordance with applicable local, state, and federal regulations before removal from the facility.
- An insect and rodent control program is in effect.

### ***Special Practices***

- Access to the laboratory is limited or restricted by the laboratory director when work with infectious agents is in progress. In general, persons who are at increased risk of acquiring infection, or for whom infection may have serious consequences, are not allowed in the laboratory or animal rooms. For example, persons who are immunocompromised or immunosuppressed may be at increased risk of acquiring infections. The laboratory director has the final responsibility for assessing each circumstance and determining who may enter or work in the laboratory or animal room.
- The laboratory director establishes policies and procedures whereby only persons who have been advised of the potential hazards and meet specific entry requirements (e.g., immunization) may enter the laboratory.
- A biohazard sign must be posted on the entrance to the laboratory when etiologic agents are in use. Appropriate information to be posted includes the agent(s) in use; the biosafety level; the required immunizations; the investigator's name and telephone number; any personal protective equipment that must be worn in the laboratory; and any procedures required for exiting the laboratory.
- Laboratory personnel receive appropriate immunizations or tests for the agents handled or potentially present in the laboratory (e.g., hepatitis B vaccine or TB skin testing).
- When appropriate and taking into consideration the agent(s) handled, baseline serum samples for laboratory and other at-risk personnel are collected and stored. Additional serum specimens may be collected periodically, depending on the agents handled or the facility's function.
- Biosafety procedures are incorporated into standard operating procedures or in a biosafety manual adopted or prepared specifically for the laboratory by the laboratory director. Personnel are advised of special hazards and are required to read and follow instructions on practices and procedures.
- The laboratory director ensures that laboratory and support personnel receive appropriate training about the potential hazards associated with the work involved; the necessary precautions to prevent exposures; and the exposure evaluation procedures. Personnel receive annual updates or additional training as necessary for procedural or policy changes.
- A high degree of precaution must always be taken with any contaminated sharp items, including needles and syringes, slides, pipettes, capillary tubes, and scalpels.
- Needles and syringes or other sharp instruments should be restricted in the laboratory for use only when

there is no alternative, such as parenteral injection, phlebotomy, or aspiration of fluids from laboratory animals and diaphragm bottles. Plasticware should be substituted for glassware whenever possible.

- Only needle-locking syringes or disposable syringe-needle units (i.e., needle is integral to the syringe) are used for injection or aspiration of infectious materials. Used disposable needles must not be bent, sheared, broken, recapped, removed from disposable syringes, or otherwise manipulated by hand before disposal; rather, they must be carefully placed in conveniently located puncture-resistant containers used for sharps disposal. Non-disposable sharps must be placed in a hard-walled container for transport to a processing area for decontamination, preferably by autoclaving.
- Syringes that re-sheath the needle, needleless systems, and other safety devices are used when appropriate.
- Broken glassware must not be handled directly by hand, but must be removed by mechanical means such as a brush and dustpan, tongs, or forceps. Containers of contaminated needles, sharp equipment, and broken glass are decontaminated before disposal according to any local, state, or federal regulations.
- Cultures, tissues, specimens of body fluids, or potentially infectious wastes are placed in a container with a cover that prevents leakage during collection, handling, processing, storage, transport, or shipping.
- Laboratory equipment and work surfaces should be decontaminated with an effective disinfectant on a routine basis; after work with infectious materials is finished; and especially after overt spills, splashes, or other contamination by infectious materials. Prior to its removal from the facility, contaminated equipment must be decontaminated according to any local, state, or federal regulations before it is sent for repair or maintenance or packaged for transport in accordance with applicable local, state, or federal regulations.
- Spills and accidents that result in overt exposures to infectious materials are immediately reported to the laboratory director. Medical evaluation, surveillance, and treatment are provided as appropriate, and written records are maintained.
- Sinks in the BSL-2 area should be scrubbed down daily with a chlorine-containing abrasive and flushed with a suitable chemical decontaminant.
- Water baths and all water reservoirs should be washed periodically with a suitable chemical decontaminant.
- Once a month, work spaces that do not get daily attention with germicide should be cleaned, as well as other lab areas where clutter accumulates (e.g., storage areas).
- Large equipment (such as incubators) should have their inner and outer surfaces damp-wiped with a decontaminant.
- Supplies should be rotated and outdated material thrown out. Unlabeled material should be eliminated.
- Clutter should be cleaned up.
- Custodial services: only personnel with appropriate authorization may enter a BSL-2 facility while BSL-2 research activity is in progress.

- Animals not involved in the work being performed are not permitted in the lab.

### ***Safety Equipment (Primary Barriers)***

- Properly maintained biological safety cabinets, preferably Class II, or other appropriate personal protective equipment or physical containment devices are to be used when:
  - Procedures that have the potential to create infectious aerosols or splashes are conducted. These may include centrifuging, grinding, blending, vigorous shaking or mixing, sonic disruption, opening containers of infectious materials whose internal pressures may be different from ambient pressures, inoculating animals intranasally, and harvesting infected tissues from animals or embryonate eggs.
  - High concentrations or large volumes of infectious agents are used. Such materials may be centrifuged in the open laboratory if sealed rotor heads or centrifuge safety cups are used, and if these rotors or safety cups are opened only in a biological safety cabinet.
- Face protection (goggles, mask, face shield, or other splatter guard) is used for anticipated splashes or sprays of infectious or other hazardous materials to the face when the microorganisms must be manipulated outside the BSC.
- Protective laboratory coats, gowns, smocks, or uniforms designated for lab use are worn while in the laboratory. This protective clothing is removed and left in the laboratory before leaving for non-laboratory areas (e.g., cafeteria, library, administrative offices). All protective clothing is either disposed of in the laboratory or laundered by the institution; it should never be taken home by personnel.
- Gloves are worn when hands may contact potentially infectious materials, contaminated surfaces, or equipment. Wearing two pairs of gloves may be appropriate. Gloves are disposed of when overtly contaminated and removed when work with infectious materials is completed or when the integrity of the glove is compromised. Disposable gloves are not washed, reused, or used for touching “clean” surfaces (keyboards, telephones, etc.). They should not be worn outside the lab. Alternatives to powdered latex gloves should be available. Hands are washed following removal of gloves.

### ***Procedures for Receiving and Inspecting Samples***

- The PI must designate one person to be responsible for the purchase of all infectious materials used in the BSL-2 lab.
- All materials that contain, or may contain, virus are to be identified as such prior to arrival at BU or BMC. This will also include all bloodborne pathogen materials, such as human tissue and body fluids. The faculty supervisor or designee is to notify Receiving when such shipments are expected and personally pick up the samples at the loading dock area and transport them to the containment facility. **Receiving is never to make such deliveries.** The primary packaging of such samples is not to be opened outside the containment facility. Samples are to be brought into the changing room and then transferred into the containment lab.
- Wearing appropriate personal protection, the authorized lab personnel are to bring samples into the

laboratory through the inner corridor, being extremely careful to close the inner door before opening the outer door.

- Packages will be placed on a tray covered with absorbent material and opened in the biosafety cabinet.
- Personnel assigned to open packages will wear lab smock, gloves, and eye protection.
- If any containers are found to be damaged, leaking or otherwise contaminated, they will be immediately isolated into a plastic bag along with all packaging materials. The lab director will be notified immediately. The incident may also need to be reported to OEHS and other agencies.
- All virus-containing samples are to be entered into the inventory logbook. The physical condition of each is to be noted.
- If, after inspection, the samples are intact, they can be placed into labeled secondary containers (unbreakable plastic containers or metal tubes) and then transferred to a storage area.
- Only staff who are authorized to do so can remove samples from storage. Removal and use of all such materials must be entered into the logbook.
- Unused cultures can be returned to storage after the outer container has been properly disinfected.

Generally BU/BMC Receiving staff delivers the laboratory supplies and materials directly to the laboratory on a routine basis. However, the Receiving staff will not deliver the BSL-2 materials directly to the laboratory as they do other materials; instead, they will notify the designated laboratory manager prior to any delivery and determine who will have to be present in the laboratory to accept the supplies arriving at the laboratory.

### ***Laboratory Facilities (Secondary Barriers)***

In a BSL-2 lab, the following conditions are to exist:

- Lockable doors should be provided for facilities that house restricted areas.
- Consideration should be given to locating new laboratories away from public areas.
- Each laboratory contains a sink for handwashing.
- The laboratory is designed so that it can be easily cleaned. Carpets and rugs in laboratories are inappropriate.
- Bench tops are impervious to water and resistant to moderate heat and the organic solvents, acids, alkalis, and chemicals used to decontaminate the work surfaces and equipment.
- Laboratory furniture is capable of supporting anticipated loading and uses. Spaces between benches, cabinets, and equipment are accessible for cleaning. Chairs and other furniture used in laboratory work should

be covered with a non-fabric material that can be easily decontaminated.

- Biological safety cabinets should be installed in such a manner that fluctuations of the room's air supply and exhaust air do not cause them to operate outside their parameters for containment. Locate BSCs away from doors, windows that can be opened, heavily traveled laboratory areas, and other potentially disruptive equipment so as to maintain the BSC's air flow parameters for containment.
- An eyewash station is readily available.
- Illumination is adequate for all activities, avoiding reflections and glare that could impede vision.
  - There are no specific ventilation requirements. However, planning of new facilities should consider mechanical ventilation systems that provide an inward flow of air without recirculation to spaces outside of the laboratory. If the laboratory has windows that open to the exterior, they are fitted with fly screens.

## Appendix F

### **Biosafety Level 3 (BSL-3) Facility Standard Operating Procedure (SOP)**

Biosafety Level 3 (BSL-3) is the recommended containment for work with concentrates or agents that may cause serious or potentially fatal disease through inhalation exposure. As such, they are subject to stricter facility design and operational controls.

BSL-3 facilities conduct research involving biological materials classified as BSL-3 and have special design and ventilation features that are incorporated during the design and construction phases and verified prior to the facility's commissioning. The plans for all BSL-3 and above facilities must be reviewed and approved in advance by both OEHS and the Biosafety Office to ensure that they are in compliance with the CDC/NIH's *Biosafety in Microbiological and Biomedical Laboratories* (BMBL) requirements. Additionally, all work with BSL-3 and above agents must be registered with the Boston Public Health Commission.

The following outlines the general requirements of BSL-3 facilities. The IBC and/or the BSO will review the site-specific operating procedures for such facilities and determine their adequacy for the proposed biological agents and activities.

#### ***Administration***

- The lab director (PI) is responsible for the facility, ensuring that personnel are adequately trained and enforcing facility policies and safety rules. If safety rules are violated, the employee involved will need re-certification training or be denied access to the lab.
- The lab director restricts entry into the lab to individuals who:
  - Have received documented training on the safety regulations for the facility and are experienced in handling infectious agents and proficient in the techniques required (see Containment Facility Approval Form); or
  - Are in training to handle infectious diseases, but only when in the presence of an experienced individual who has agreed to be responsible for training; or
  - Are visitors who are accompanied at all times by an experienced individual who has agreed to be responsible for the visitor (after the lab director's approval) and for fully informing the visitor of the nature of the research. The PI will determine what work must stop during the visit and what materials must be put away. Individuals without professional reasons for visiting the facility will generally not be permitted access.
- Any mechanics who must enter the facility will wear the same protective clothing as the researchers and, in BSL-3 areas, sign the entry logbook. Infectious materials will be put away and any work utilizing infectious materials will not be done while a mechanic is present (see *Procedures for Performing Preventative Maintenance*).

- Persons under 18 and anyone at increased risk may **not** enter.
- Violations of safety rules will be reported to the PI and/or Biosafety Officer. Serious or repeated infractions will be grounds for denying further access to the facility.
- The Biosafety Officer, with the assistance of OEHS, will make yearly inspections of the laboratories. Researchers will be responsible for overseeing the facility's day-to-day operation. They will orient new employees about the rules for the facility in combination with the OSHA Bloodborne Pathogen training offered through OEHS and specialized BSL-3 training for individuals working in a BSL-3 containment lab.
- The facilities manager will supervise preventative maintenance. All BSL-3 containment suites will undergo formaldehyde decontamination at least annually so that all lab equipment can be tested. Pest control will also be provided through Facilities.

### ***Standard Microbiological Practices***

- Access to the lab is limited or restricted by the lab director when work with infectious agents is in progress (see *Special Practices*). Entry to the containment is through a controlled access anteroom. The anteroom's outer door, as well as the inner door to any containment lab, can be opened only with a special computerized card. Card access to each containment lab is controlled by the PI along with the approval of the Biosafety Officer.
- Persons wash their hands after handling infectious materials and animals and before leaving the lab.
- Eating, drinking, smoking, applying cosmetics, inserting or removing of contact lenses, and storing food are prohibited in the lab. Persons who wear contact lenses should also wear goggles or a face shield.
- Mouth pipetting is prohibited.
- All procedures with infectious particles are performed in a biological safety cabinet or other physical containment device to minimize the exposure of personnel to aerosols.
- Work surfaces are decontaminated at least once every work day and immediately after any spill of viable material. A bottle of disinfectant is kept in every work area.
- All infectious wastes are decontaminated before disposal by approved methods. Other contaminated items are decontaminated before washing and reuse. Materials to be decontaminated (in the autoclave) are placed in a

durable, leak-proof container that is closed and decontaminated on the outside before removal to the inner corridor.

- An insect and rodent control program is in effect, and no roach or mice problems exist.
- Lower containment experiments in the same lab must follow BSL-3 practices.

### *Special Practices*

- Lab doors are kept closed while work is in progress. A BSL-3 sign is posted on the outside of the anteroom along with a universal biohazard warning sign.
- The lab director controls access to the lab and restricts it to advised persons whose presence is required for the work being conducted. Persons who are at an increased risk of acquiring infection or for whom infection may be unusually hazardous are not allowed in the work area. According to NIH guidelines, persons under the age of 16 may not enter the laboratory. BU/BMC policy restricts minors under 18. No custodial or other maintenance personnel are permitted to enter the BSL-3 lab unless written authorization from the PI has been obtained. The director has the final responsibility for assessing each circumstance.
- The lab director establishes policies and procedures whereby only persons who have been advised of the potential hazard, who meet any specific training and entry requirements, and who comply with all procedures may enter the work area(s).
- When infectious materials are present, a universal biohazard warning sign is posted on the access door(s) to the work area(s). The sign identifies the agent, lists the name and telephone number of the lab director or other responsible person(s), and indicates any special requirements for entering the lab (e.g., immunization, personal protective measures). Equipment used to store or grow cultures shall also be posted with the universal biohazard label.
- Laboratory personnel receive appropriate immunization or tests for the agents handled or potentially present (e.g., hepatitis B vaccine).
- If deemed necessary by the PI, the Occupational Health Program or Institutional Biosafety Committee collects baseline serum samples.
- Personnel are advised of special hazards and **required to read and follow** instructions on practices and procedures.
- The lab director ensures that lab personnel receive appropriate training on the work's potential hazards, the necessary precautions to prevent exposure, and emergency procedures. Personnel receive additional training as needed.
- The lab director is responsible for ensuring that, before working with infectious materials, all lab personnel demonstrate proficiency in the handling of hazardous agents/materials and in the other practices specific to



the facility. Competent scientists who are experienced in working with these agents/materials help provide the training and supervision.

- Caution must be used with any sharp items. Use of hypodermic needles and Pasteur pipettes is restricted in the BSL-3 lab. Extreme care should be used to avoid auto-inoculation and aerosol generation. Contaminated sharps must be promptly placed in a puncture-resistant sharps container and decontaminated before disposal. Broken glassware must not be handled directly by hand. Plasticware should be substituted whenever possible.
- No work with infectious materials is conducted in open vessels on the open bench. All activities involving such materials are performed in BSCs or other physical containment devices within the containment module. Opening centrifuge rotor heads and caps must also be done inside a BSC.
- Laboratory equipment and work surfaces are to be decontaminated after work with infectious materials, especially after spills or splashes. Contaminated equipment should be decontaminated before being sent for repair, maintenance, or transport, and before removal from the facility.
- Only staff authorized to do so can remove cultures or infected cells from storage. Removal and use of all such cultures must be entered into the logbook. Containers that prevent leakage during handling, storage, or transport are to be used. Unused cultures can be returned to storage after the outer container has been properly disinfected.
- All potentially contaminated items from the work area(s) are sterilized by a method shown to be effective for the organism in use before disposal or reuse.
- **Personnel properly trained and equipped decontaminate and clean up spills of infectious materials. See Chapter 8.**
- Spills and accidents that result in overt or potential exposure to infectious material are immediately reported to the lab director, who then notifies OEHS. Medical evaluation, surveillance, and treatment are provided as appropriate, and written records are maintained.
- Animals and plants not part of the work being conducted are not permitted in a BSL-3 lab.

#### ***Safety Equipment (Primary Containment Barriers)***

- Biological safety cabinets (Class IIB) are used for all manipulations of infectious materials.
- In addition to a BSC, other appropriate combinations of personal protective equipment (such as special clothing or face protection) and physical containment devices (such as centrifuge safety caps and sealed centrifuge rotors) are used for all activities that pose a threat of aerosol exposure to infective agent(s).
- This special equipment must be used for manipulations of cultures and infected animals.

- If handling virus, face protection (such as mist masks and glasses, or face shields) should be worn.
- Respirators may be required under certain circumstances. Personnel will be cleared by the Occupational Health Program and be fit tested and instructed by the Industrial Hygiene Office.
- In the lab, disposable or reusable lab clothing that protects street clothing (e.g., long-sleeved, solid front or wrap-around gowns, scrub suits, or coveralls) is required. When working with BSL-3 infectious agents, the gown should be impervious to liquids and have elasticized cuffs. Lab clothing is not worn outside the lab and is decontaminated before disposal or laundering. Cloth lab gowns used in the facility have to be processed once a week. Front-button lab coats are not suitable for a BSL-3 lab. Street clothing, such as coats and hats, are not kept in the lab.
- Double gloves are worn when working with infectious materials or when hands may come in contact with contaminated surfaces or equipment.

### ***Laboratory Facility***

- The laboratory is segregated from areas that are open to unrestricted traffic in the building. Access into the lab is through at least **two** sets of self-closing doors, with a change room in between.
- The lab contains a sink for handwashing that is foot operated and is located near the exit door. Handwashing facilities with automatic faucets are also located in the anteroom.
- The interior surfaces of walls, floors, and ceilings are water resistant. Penetrations in these surfaces are sealed.
- Bench tops are impervious to water and resistant to acids, alkalis, organic solvents, and moderate heat.
- Spaces between benches, cabinets, and equipment are accessible for cleaning.
- Windows are sealed.
- An autoclave for decontamination of laboratory waste is located in the laboratory. A chemical disinfectant addition system is connected to the sink plumbing. An incinerator is also available if needed.
- The lab is under negative pressure and has directed airflow, with air drawn in through the clean entry area. The exhaust air is not recirculated to any area and is HEPA filtered prior to being discharged to the outside. The exhaust is dispersed away from occupied areas and air intakes. Personnel must verify that the direction of airflow into the lab is correct before entering.
- The HEPA-filtered exhaust air from Class II BSCs is discharged directly outside. The manner of exhausting the cabinet must not interfere with the air balance of the cabinets or building exhaust system.

- Vacuum lines are protected by HEPA filters and disinfected traps.
- An eyewash spray is readily available at each sink.
- Additional design features are listed in Appendix C.

### ***Removal of Materials from the Facility***

• Material to be removed from the facility shall be properly decontaminated by autoclaving or by chemical disinfection. Autoclaving is the preferred mode of decontamination and should be used for all refuse and labware. Items that cannot be autoclaved shall be decontaminated by wiping the surfaces thoroughly with 70% ethanol, 2% Lysol.

**Note:** *The Massachusetts Water Resources Authority prohibits disposal of mercury-containing liquids in waste water. Clorox contains mercury. BU/BMC recommend Elite bleach or Austin's, which are mercury free.*

- Before removing any major piece of equipment from the BSL-3 lab, the Biosafety Officer must be notified to determine the best course of action. Depending on the specific situation, the facility's use may be restricted for use or the facility shut down during removal of the equipment.
- Reusable containers include tissue culture media bottles, reagent bottles, cylinders, and beakers. They shall be decontaminated by immersion in 10% bleach solution for at least 10 minutes (care should be taken to fill completely). The items will be drained and washed by the scientists or placed into a clean pan, covered, removed from the BSL-3 lab, and autoclaved by the scientists before returning to the dishwashing facility. Autoclaved reusable containers will be kept to a minimum.
- In case of a breakdown in the -70° C freezer, frozen material will be placed into clean biohazard bags, sealed, and removed either to a freezer inside another containment lab or, if space is not available, to a labeled backup freezer in the institute.
- DNA, RNA, proteins, or other biological materials prepared from infectious agents, or infected cells created by using extraction procedures that completely inactivate the agent, may be removed from the containment laboratory.
- Viruses and infected cells shall be packaged according to Department of Transportation and U.S. Public Health Service regulations. The primary container will be wiped with 70% ethanol before removal from the BSC and then placed inside a clean secondary container outside the cabinet. Gloves will be changed between transfers. Absorbent material will be placed between the primary and secondary containers. The outside of the secondary container will then be decontaminated by wiping with 70% ethanol prior to removal from the facility. Such containers will be labeled and transported or stamped and mailed by the PI and not handled by anyone else. Certain materials require special shipping labels and/or licenses. NIH also requires that prior to providing DNA materials to collaborators, a letter stating recipient institutional

compliance with the appropriate containment level is received.

- Any infectious DNA, virus, or cellular material that is removed from the facility will be recorded with the date, the type of material, the amount of material, and the origin or destination of the material. File a copy of the recipient's permit to receive and use.

### ***Cleaning the Facility***

- Researchers will perform all daily housekeeping routines within the BSL-3 lab, including trash removal. The general BU/BMC housekeeping staff will not enter the laboratory to do any regular cleaning.
- All the cleaning and decontamination procedures shall be performed only by individuals authorized to work in the BSL-3 facility.
- A bottle of a suitable chemical disinfectant (e.g., ethanol, Lysol, and bleach) shall be kept in every work area for spills. Dilution will be made as needed.
- Work surfaces are decontaminated when work is finished, at the end of every work day, and immediately after any spill of viable material. Large equipment, such as incubators and centrifuges, will have inner and outer surfaces damp-wiped with disinfectant weekly.
- The work surfaces of BSCs are decontaminated when work with organisms containing recombinant DNA molecules is finished.
- Sinks in the BSL-3 lab should be scrubbed down daily with a chlorine-containing abrasive and flushed.
- Water baths and all water reservoirs shall be washed periodically with a suitable chemical decontaminant if copper sulfate has not been added to the water.
- On a routine basis, the floor of the BSL-3 containment is thoroughly wiped down with a suitable chemical decontaminant and work spaces that do not get daily attention are cleaned up with germicide.
- Solid waste is decontaminated and then disposed only by the authorized persons (see Waste Disposal section).
- Routinely (e.g., once a year), the BSL-3 lab will be sealed and decontamination will be done as per BU/BMC standard procedure (e.g., by perfusion with formaldehyde gas). HEPA filter changing and testing will also be done at this time. Records of all such activities will be maintained at the facility.

### ***Personnel Training***

The training for BSL-3 facilities must address various constituencies, including:

- Laboratory workers with contact with the biological materials
- Animal facility workers

- General employees (i.e., non-laboratory workers)
- Facilities and maintenance workers
- Institutional first responders
- First responders from external agencies

The purpose of a comprehensive training program is to ensure employees are aware of the hazards to which they might be exposed and are familiar with safety work procedures and how to protect themselves, their colleagues, and the environment from potential exposure. Site-specific training for BSL-3 facilities is an IBC mandate and requires additional training in the facility SOP.

The laboratory director is responsible for this training and should contact the BSO for assistance if needed.

The topics to be included in the training program will vary depending on the biological materials used and the types of research conducted. At a minimum, however, the following areas should be addressed:

- Biology of organism used
- Use within facility and standard precautions
- Disinfectants
- Record keeping and data entry
- Lab inspections and housekeeping duties
- Emergency response
- Fire control and suppression
- Medical emergencies
- Entry/exit requirements and other administrative measures
- Safety equipment; primary and secondary barriers
- Receipt and inspection of cultures
- Transport in laboratory
- Storage, segregation, and record-keeping in laboratory
- Removal of materials from facility
- Spill control
- Utility disconnection
- Control panels, function and shut off
- Equipment malfunctions
- Reporting

### ***Laboratory Layout and Entry/Exit Rules***

The lab director restricts access to all BSL-3 labs to trained personnel. Visitors may not enter a laboratory without proper training and authorization through IBC and/or BSO. All persons must comply with the entry and exit procedure. Keys are authorized by the lab director and no key card access to animal or BSL-3 containment areas is allowed without prior animal or BSL-3 training through LASC and OEHS.

### • **Entry/Exit procedure for BSL-3 Laboratories Only**

- Lab notebooks are not to be brought into the containment section of the lab; if they are, they may not be removed. Notes may be made on paper, posted on the window, and then recopied into notebooks on the outside, taking care to avoid transcription errors.
- Paper may be kept in the lab or disposed of, but it may not be removed from the facility.
- Notebooks that have **not** been taken into the contaminated area of the lab may be removed from the facility after wiping the covers with 70% ethanol (for this purpose, vinyl-clad binders might be useful).
- The lab is also designed for computer capability and faxing. Other options include data collection with printed output elsewhere; digital writing tablets; or audio tape records. However, the permanent record of all data and notes must be written or glued in the **bound** notebook.

### **Before entering the anteroom**

- Identify a check-in person prior to working alone. This person will be responsible for periodically checking with the worker (e.g., drop in, phone call) to ensure continued safety of the individual working alone in the facility. The check-in person will either enter the facility or summon assistance if there is no response from the worker.

### **In the anteroom**

- Sign the user's log, which shall be a bound, permanent log, not loose sheets of paper.
- Put on solid-front or wrap-around gown and double gloves. If handling virus, the worker should wear a separate smock plus a mask that provides face protection from splashes.
- Check that antiseptic soap, towels, and water are available for clean up.

### **Entering the inner corridor**

- Do not enter the inner corridor unless air flows in from the anteroom. Check the airflow direction indicator above the door.

### **Entering and working in the laboratory**

- Do not enter the lab unless air flows into the lab when opening the door. Immediately report problems to the Medical Campus Control Center at (617) 638-6666 or OEHS at (617) 638-8830.
- Check that phone is operational and emergency numbers are posted. Do not work in the suite unless a means to summon help in an emergency is available. Any problems should be reported to Maintenance.
- Before beginning work, check condition of work areas. Areas should be clean. If they aren't, no assumptions should be made about what materials were left. The last person logged in should be called for assistance. Wipe down work areas with disinfectant before beginning work.

- All work with open containers containing potentially infectious material is confined to biological safety cabinets. Keep grills clear and the sash at a proper level. Use minimum equipment in the cabinet to allow for effective air flow; cabinet blowers should be left on at all times. Work from clean to dirty area. Discard contaminated outer gloves and any contaminated clothing immediately in the laboratory waste.
- Centrifuge buckets shall be secured with biocontainment covers when spinning infectious materials. Safety cap must be used at all times.
- Do not use sharp items or instruments, and use plastic instead of glass.
- Transport of biological materials outside of the cabinets must be in double containers (unbreakable and closed), which will contain spills.
- Waste should be confined to the BSC and covered containers.
- The outside surface of any materials or equipment leaving the lab must be swabbed down with disinfectant and/or placed in a clean outer bag (see waste disposal).
- Wipe down the work area with disinfectant after completing work.
- Discard outer gloves and any contaminated clothing in the laboratory waste. Remove carefully to keep the exterior of all contaminated items away from the skin.

**Exiting the laboratory, entering the anteroom:**

- Remove shoe covers and step to a clean area of the anteroom, discarding the covers into a biohazard waste receptacle. Hang up any reusable lab gown or discard Tyvec gown in a biohazardous waste receptacle. Remove surgical mask and any eye protection and discard in waste. Lastly, remove inner gloves by turning inside out and discard in waste. Do not carry anything out of the suite, including lab notebooks, personal protective equipment, or other materials.
- Wash hands well with soap and water using the automatic faucet.
- Sign out.
- Let laboratory personnel know when work in the suite is complete.

**Laboratory Layout**

The laboratory's layout, the equipment present, and other physical features are dependent on the activities conducted within the facility. In general, the laboratory is laid out in a manner that the least-hazardous activities are closest to the entrance/exits and the flow of personnel is in a direction that reduces the potential for spread of contamination within the laboratory. The Biosafety Officer will review all facility layouts with the laboratory director to ensure that the final configuration and placement of equipment meets the laboratory's functional and safety needs.

**The following guidelines are intended to provide the laboratories with commonly acceptable criteria.**

Each laboratory room of all BSL-3 containment labs should have:

- **Class II B biological safety cabinets**

- Each unit should have an alarm at the discharge of the hood that will sound if the CFM drops below 250.
- A Class II B BSC is designed with inward air flow at a velocity to protect personnel (80-100 linear feet per minute); high-efficiency particulate air (HEPA) filtration of the air flow down across the work surface (vertical laminar flow) for protection of the research material; and HEPA-filtered exhaust air for environmental protection.
- Personnel must sign up for use of the cabinets (name, date, times) if the laboratory is a heavy-use area.

- **Waste container inside BSCs**

- If a small plastic pail is used, it contains two red biohazard bags as liners.
- Radioactive biohazardous waste will be collected in a separately labeled container when radioactivity is used.

- **Aspirator flasks in BSCs**

- All liquid wastes (e.g., cell culture supernatants) are collected inside the BSC in 4-liter aspirator flasks or special 3-liter, plastic-coated aspirator security bottles containing the appropriate decontaminant (e.g., Clorox bleach, 10% final concentration) and labeled accordingly. The containers can be disconnected from the aspiration unit by quick snap, double-sealing connections (see Waste Section). The vacuum line is protected by a HEPA filter.

- **Waste containers outside the BSCs**

- All articles, such as paper and plastic wrappers of serological pipettes, are collected in a covered waste container lined with double red biohazard bags on the floor adjacent to the BSCs.

- **A foot- or elbow- operated sink with a disinfectant addition system and a holding tank located in the lab.**

- An additional sink, preferably with an automatic faucet, should be placed in the anteroom.
- Each sink should have an eyewash station.

- **Phone, fax, and computer capability**

- **A second fire, emergency-only, self-closing exit door with a fireproof glass window to the main hall.**
- Nothing is allowed to be posted on the glass panels.

- **Inner corridor**

- **A pass-through double-door autoclave for waste**

- **Anteroom with clean supplies, such as lab gowns, masks, gloves, plastic bags, soap, and paper towels, along with the entry logbook.**



- All persons entering or leaving the facility must log in and out.
- This information is maintained for 20 years. A card access system to the anteroom and to the lab also records entry.
- **An alarm cabinet for negative balance of the lab areas with an intercom system installed.**
- **For pest control, boric acid should be sprayed behind all walls during construction and a rigorous pest management plan must in place.**
- **All hoods, incubators, and -70° C freezers are supplied with emergency power.**

### *Inspection and Maintenance of Containment Facility*

The purpose of laboratory inspection is to ensure that the working environment is safe, all pieces of equipment are functioning properly, and that administrative controls are observed. A robust post-approval monitoring program is designed to identify problems early and to develop preventive measures.

The scope and frequency of the inspections will depend on the specific agents used, type of activities conducted, and the laboratory record of maintaining a safe and compliance facility. In general, it will follow the IBC-approved Comprehensive Audit Procedures (see Appendix U, IBC Oversight Program) and will have additional site-specific elements added.

As part of its approval, the IBC may require additional self-inspections (e.g., weekly) to be conducted by the facility director or his or her designee. In these instances, the BSO will develop site-specific inspection criteria that the facility must follow. During its routine inspections, the BSO will review the self-inspection records and verify their efficacy.

### *Procedures for Performing Preventative Maintenance*

The proper performance and maintenance of equipment in any laboratory is important, and in a BSL-3 facility, it is of paramount importance. Engineering controls are a significant component of the facility's overall safety design. Therefore, a comprehensive preventive maintenance and inspection program is critical to the safe operations of such facilities.

The specific scope and extent of the preventive maintenance and equipment inspection will be dependent on the facility and its design. However, the following is a list of minimum recommendations:

#### **• Equipment Maintenance**

The following physical plant equipment is checked and inspected on a routine basis:

- exhaust fans
- heating/air conditioning equipment

- autoclave
- vacuum
- air compressor and CO<sub>2</sub> tank
- disinfectant addition system
- emergency generator

**Note:** *Specific schedules are developed for each facility.*

• **Checking** these devices consists of observing whether the device is operating normally. **Inspecting** these devices consists of visually inspecting the device's integral parts, such as seals, bearings, wiring, power supply and brushes, and replacing/repairing defective parts.

• Equipment located inside the containment lab will be inspected in conjunction with the annual decontamination by perfusion with formaldehyde. During the period, no research work will be conducted, and all infectious materials will be sealed and secured.

• Any piece of equipment needing repair at any other time will be decontaminated before a mechanic is allowed entry. The area around the equipment will also be decontaminated and all infectious materials will be secured. The mechanics must wear protective clothing and sign the logbook. Upon completion of the repair, the scientist will decontaminate all tools.

• **Biological Safety Cabinet Maintenance**

Each unit is inspected annually by a qualified individual to document performance and efficiency and to provide annual certification. The integrity of the HEPA filter is also tested.

• **Emergency Equipment Testing**

All safety equipment is checked as specified on the weekly inspection form. Inspect the emergency equipment following the instructions below:

• ***Emergency Generator***

- a. Disconnect the laboratory/generator contact.
- b. Next, locate the emergency test run switch and turn to test position.
- c. The generator motor should begin to turn over.
- d. When the engine starts, run the generator for 15 minutes and then turn the test switch to "off."
- e. Reset the laboratory/generator connection to "on" and return the "test run" switch to "auto."

• ***Alarms***

- a. Check the pressure-sensitive alarm biannually.
- b. Fire alarm is checked monthly and inspected biannually.
- c. Personnel should be stationed in various locations to confirm that the alarms are activated.

• **Emergency Showers and Eye Wash Stations**

- a. Check the eye wash stations weekly by turning on the flow of water and watching for adequate delivery that is clean and free of debris or rust.
- b. Showers and eyewash stations are inspected every six months for proper operation and flow rate. A log is maintained.

• **Fire Extinguishers**

- a. Checked monthly and inspected annually.

• **Recordkeeping Audits**

- Check the entrance logbook, the compounds use logbook, the inspection logs, the waste log sheets, and autoclave charts for complete entries on a weekly basis.
- Ensure that all laboratory employees attend safety training sessions and keep a log of the attendance.
- The Biosafety Officer shall perform an audit of these records on an annual basis.

**Form B1  
 Certification and Maintenance of BSL-3 Laboratories**

**BSL-3 LAB QUARTERLY  
 MAINTENANCE**

**Subject: CHECKLIST**  
**Date:**  
**Time:**  
**Temp:**  
**Humidity:**

MAINTENANCE				
ITEM	SUBJECT	Pass	Fail	Comment/Correction
<b>1</b>	<b>Exhaust Fan No.</b>			
a	Belts	<input type="checkbox"/>	<input type="checkbox"/>	
b	Pulleys	<input type="checkbox"/>	<input type="checkbox"/>	
c	Hardware	<input type="checkbox"/>	<input type="checkbox"/>	
d	Damper & Actuator	<input type="checkbox"/>	<input type="checkbox"/>	
e	Lubricate Drive Bearings	<input type="checkbox"/>	<input type="checkbox"/>	

f	Electrical Connections	<input type="checkbox"/>	<input type="checkbox"/>	
g	Motor Voltage	<input type="checkbox"/>	<input type="checkbox"/>	
h	Motor Amperage	<input type="checkbox"/>	<input type="checkbox"/>	
<b>2</b>	<b>Exhaust Fan No.</b>			
a	Belts	<input type="checkbox"/>	<input type="checkbox"/>	
b	Pulleys	<input type="checkbox"/>	<input type="checkbox"/>	
c	Hardware	<input type="checkbox"/>	<input type="checkbox"/>	
d	Damper & Actuator	<input type="checkbox"/>	<input type="checkbox"/>	
e	Lubricate Drive Bearings	<input type="checkbox"/>	<input type="checkbox"/>	
f	Electrical Connections	<input type="checkbox"/>	<input type="checkbox"/>	
g	Motor Voltage	<input type="checkbox"/>	<input type="checkbox"/>	
h	Motor Amperage	<input type="checkbox"/>	<input type="checkbox"/>	
<b>3</b>	<b>VFD No.</b>			
a	Electrical Connections	<input type="checkbox"/>	<input type="checkbox"/>	
b	Frequency	<input type="checkbox"/>	<input type="checkbox"/>	
c	%	<input type="checkbox"/>	<input type="checkbox"/>	
d	Voltage	<input type="checkbox"/>	<input type="checkbox"/>	
e	Amperage	<input type="checkbox"/>	<input type="checkbox"/>	

MAINTENANCE				
ITEM	SUBJECT	Pass	Fail	Comment/Correction
<b>4</b>	<b>VFD No.</b>			
a	Electrical Connections	<input type="checkbox"/>	<input type="checkbox"/>	
b	Frequency	<input type="checkbox"/>	<input type="checkbox"/>	
c	%	<input type="checkbox"/>	<input type="checkbox"/>	
d	Voltage	<input type="checkbox"/>	<input type="checkbox"/>	
e	Amperage	<input type="checkbox"/>	<input type="checkbox"/>	
<b>5</b>	<b>HEPA Filter No.</b>			
a	Δ P	<input type="checkbox"/>	<input type="checkbox"/>	
b	Change Filter PI/B&V	<input type="checkbox"/>	<input type="checkbox"/>	
<b>6</b>	<b>HEPA Filter No.</b>			
a	Δ P	<input type="checkbox"/>	<input type="checkbox"/>	
b	Change Filter PI/B&V	<input type="checkbox"/>	<input type="checkbox"/>	
<b>7</b>	<b>Biosafety Cabinets</b>			
a	Recertification PI/B&V	<input type="checkbox"/>	<input type="checkbox"/>	
<b>8</b>	<b>Biosafety Cabinets</b>			

a	Recertification PI/B&V	<input type="checkbox"/>	<input type="checkbox"/>	
<b>9</b>	<b>Room No. Condition</b>			
a	Lights	<input type="checkbox"/>	<input type="checkbox"/>	
b	Caulking	<input type="checkbox"/>	<input type="checkbox"/>	
c	Outlets Sealed	<input type="checkbox"/>	<input type="checkbox"/>	
d	Sinks	<input type="checkbox"/>	<input type="checkbox"/>	
e	Faucets	<input type="checkbox"/>	<input type="checkbox"/>	
f	Sprinklers	<input type="checkbox"/>	<input type="checkbox"/>	
g	Eye Wash	<input type="checkbox"/>	<input type="checkbox"/>	
h	Safety Shower	<input type="checkbox"/>	<input type="checkbox"/>	
i	RO Water	<input type="checkbox"/>	<input type="checkbox"/>	
j	Paint (Epoxy)	<input type="checkbox"/>	<input type="checkbox"/>	

MAINTENANCE				
ITEM	SUBJECT	Pass	Fail	Comment/Correction
<b>10</b>	<b>Room No. Condition</b>			
a	Lights	<input type="checkbox"/>	<input type="checkbox"/>	
b	Caulking	<input type="checkbox"/>	<input type="checkbox"/>	
c	Outlets Sealed	<input type="checkbox"/>	<input type="checkbox"/>	
d	Sinks	<input type="checkbox"/>	<input type="checkbox"/>	
e	Faucets	<input type="checkbox"/>	<input type="checkbox"/>	
f	Sprinklers	<input type="checkbox"/>	<input type="checkbox"/>	
g	Eye Wash	<input type="checkbox"/>	<input type="checkbox"/>	
h	Safety Shower	<input type="checkbox"/>	<input type="checkbox"/>	
i	RO Water	<input type="checkbox"/>	<input type="checkbox"/>	
j	Paint (Epoxy)	<input type="checkbox"/>	<input type="checkbox"/>	
<b>11</b>	<b>Room No. Condition</b>			
a	Lights	<input type="checkbox"/>	<input type="checkbox"/>	
b	Caulking	<input type="checkbox"/>	<input type="checkbox"/>	
c	Outlets Sealed	<input type="checkbox"/>	<input type="checkbox"/>	
d	Sinks	<input type="checkbox"/>	<input type="checkbox"/>	
e	Faucets	<input type="checkbox"/>	<input type="checkbox"/>	
f	Sprinklers	<input type="checkbox"/>	<input type="checkbox"/>	
g	Eye Wash	<input type="checkbox"/>	<input type="checkbox"/>	
h	Safety Shower	<input type="checkbox"/>	<input type="checkbox"/>	

i	RO Water	<input type="checkbox"/>	<input type="checkbox"/>	
j	Paint (Epoxy)	<input type="checkbox"/>	<input type="checkbox"/>	
<b>12</b>	<b>Room No.</b>			
	<b>Condition</b>			
a	Lights	<input type="checkbox"/>	<input type="checkbox"/>	
b	Caulking	<input type="checkbox"/>	<input type="checkbox"/>	
c	Outlets Sealed	<input type="checkbox"/>	<input type="checkbox"/>	
d	Sinks	<input type="checkbox"/>	<input type="checkbox"/>	
e	Faucets	<input type="checkbox"/>	<input type="checkbox"/>	
f	Sprinklers	<input type="checkbox"/>	<input type="checkbox"/>	
g	Eye Wash	<input type="checkbox"/>	<input type="checkbox"/>	
h	Safety Shower	<input type="checkbox"/>	<input type="checkbox"/>	
i	RO Water	<input type="checkbox"/>	<input type="checkbox"/>	
j	Paint (Epoxy)	<input type="checkbox"/>	<input type="checkbox"/>	

All unacceptable items must be described and corrective action listed.

## Appendix G

### Biosafety Level 4 (BSL-4) Requirements

Use of Biosafety Level 4 (BSL-4) agents is subject to very strict federal, state, and local requirements and can only be undertaken if the Institutional Biosafety Committee has reviewed the application, facility design, and specific work practices and approved the project.

*The following guidelines are intended to provide the investigators a basis for such application preparation and are not intended to constitute a comprehensive, project-specific guide.* Each facility will have a site-specific set of operating procedures that must be approved by the IBC.

A BSL-4 facility is required for work with high hazard and exotic agents that pose a high individual risk of aerosol-transmitted laboratory infections and life-threatening disease.

**Note:** *BSL-4 facilities must develop a site-specific biosafety manual based on the general outlines in this appendix.*

#### General requirements

- Individuals working in such facilities must have specific and thorough training in:
  - Handling of extremely high hazard infectious agents
  - Primary and secondary containment requirements
  - Standard and special practices
  - The containment equipment and the laboratory design characteristicsIn addition, they are supervised by competent scientists who are trained and experienced in working with these agents.
- Access to the laboratory is strictly controlled by the laboratory director.
- The facility is in a separate building.
- A specific facility operations manual is prepared or adopted.
- Within work areas of the facility:
  - All activities are confined to Class III biological safety cabinets, or Class II biological safety cabinets used with one-piece positive pressure personnel suits ventilated by a life-support system.
  - The BSL-4 laboratory has special engineering and design features to prevent microorganisms from being disseminated into the environment.

#### Training

The purpose of a comprehensive training program is to ensure that the employees are aware of the hazards to which they might be exposed and are familiar with safety work procedures and how to protect themselves, their colleagues, and the environment from potential exposure. The training requires for BSL-4 facilities will include all of the categories listed in BSL-3.

Additional site-specific training for BSL-4 facilities is an IBC mandate and requires additional training in the

facility standard operating procedure (SOP).

Training for BSL-4 facilities must address various constituencies:

- Laboratory workers with contact with the biological materials
- Animal facility workers
- General employees (i.e., non-laboratory workers)
- Facilities and maintenance workers
- Institutional first responders
- First responders from external agencies

The laboratory director is responsible for this training and should contact the BSO for assistance if needed.

The facility will also have routine emergency and evacuations drills and site-specific SOP for safety and security.

### ***Standard Microbiological Practices***

- Access to the laboratory is limited by the laboratory director when experiments are in progress.
- Policies for safe handling of sharps are instituted.
- All procedures are performed carefully to minimize the creation of aerosols.
- Work surfaces are decontaminated at least once a day and after any spill of viable material.
- All waste is decontaminated before disposal by an approved method, such as autoclaving.
- A pest control program is in effect.
- Only persons whose presence in the facility or individual laboratory rooms is required for program or support purposes are authorized to enter.
- The supervisor has the final responsibility for assessing each circumstance and determining who may enter or work in the laboratory.
- Access to the facility is limited by means of secure, locked doors; accessibility is managed by the laboratory director, BSO, or other person responsible for the facility's physical security.
- Before entering, persons are advised of the potential biohazards and instructed as to appropriate safeguards for ensuring their safety.
- Authorized persons comply with the instructions and all other applicable entry and exit procedures.
- An entry/exit control log is in effect either via an electronic access control for each individual or a logbook, signed by all personnel, indicating the date and time of each entry and exit.
- Practical and effective protocols for emergency situations are established.
- When infectious materials or infected animals are present in the laboratory or animal rooms, hazard warning signs, incorporating the universal biohazard symbol, are posted on all access doors.
- The sign identifies the agent, lists the name of the laboratory director or other responsible person(s), and indicates any special requirements for entering the area (e.g., the need for immunizations or respirators).
- Laboratory personnel receive available immunizations for the agents handled or potentially present in the laboratory.
- A biosafety manual is prepared or adopted.



- Personnel are advised of special hazards and are required to read and follow instructions on practices and procedures.
- Laboratory and support personnel receive appropriate training on the potential hazards associated with the work involved, the necessary precautions to prevent exposures, and the exposure evaluation procedures. Personnel receive annual updates or additional training as necessary for procedural changes.
- Personnel enter and leave the laboratory only through the clothing change and shower rooms. They take a decontaminating shower each time they leave the laboratory.
- Personnel use the airlocks to enter or leave the laboratory only in an emergency.
- Personal clothing is removed in the outer clothing change room and kept there.
- Supplies and materials needed in the facility are brought in by way of the double-door autoclave, fumigation chamber, or airlock, which is appropriately decontaminated between each use.
  - After securing the outer doors, personnel within the facility retrieve the materials by opening the interior doors of the autoclave, fumigation chamber, or airlock.
  - These doors are secured after materials are brought into the facility.
- A high degree of precaution must always be taken with any contaminated sharp items, including needles and syringes, slides, pipettes, capillary tubes, and scalpels.
  - Needles and syringes or other sharp instruments are restricted in the laboratory for use only when there is no alternative, such as for parenteral injection, phlebotomy, or aspiration of fluids from laboratory animals and diaphragm bottles.
  - Plasticware should be substituted for glassware whenever possible.
  - Only needle-locking syringes or disposable syringe-needle units (i.e., needle is integral to the syringe) are used for injection or aspiration of infectious materials.
  - Used disposable needles must not be bent, sheared, broken, recapped, removed from disposable syringes, or otherwise manipulated by hand before disposal; rather, they must be carefully placed in conveniently located puncture-resistant containers used for sharps disposal.
  - Non-disposable sharps must be placed in a hard-walled container for transport to a processing area for decontamination, preferably by autoclaving.
  - Syringes that re-sheath the needle, needleless systems, and other safety devices are used when appropriate.
  - Broken glassware must not be handled directly by hand, but must be removed by mechanical means, such as a brush and dustpan, tongs, or forceps.
  - Containers of contaminated needles, sharp equipment, and broken glass must be decontaminated before disposal, according to any local, state, or federal regulations.
  - Biological materials in a viable or intact state must be removed in accordance with a protocol that has been approved by the IBC.
  - Biological materials removed from the laboratory are transferred to a non-breakable, sealed container.
- All materials (except biological materials that are to remain in a viable or intact state) must be removed from the BSL-4 laboratory *only after* they have been autoclaved or decontaminated.
- Equipment or material that might be damaged by high temperatures or steam may be decontaminated by gaseous or vapor methods in an airlock or chamber designed for this purpose.

- Laboratory equipment is decontaminated routinely after work with infectious materials is finished, and especially after overt spills, splashes, or other contamination with infectious materials. Equipment is decontaminated before it is sent for repair or maintenance.
- Appropriate professional staff or others properly trained and equipped to work with concentrated infectious material contain and clean up spills of infectious materials. A spill procedure is developed and posted within the laboratory.
- A system must be established for reporting laboratory accidents and exposures and employee absenteeism, and for the medical surveillance of potential laboratory-associated illnesses. Written records must be maintained.
- An essential adjunct to such a reporting-surveillance system is the availability of a facility for the quarantine, isolation, and medical care of personnel with potential or known laboratory-associated illnesses.
- Materials not related to the experiment being conducted (e.g., plants, animals, and clothing) are not permitted in the facility.

### ***Primary Barriers***

All procedures within the facility are conducted in the Class III biological safety cabinet or in Class II biological safety cabinets used in conjunction with one-piece positive pressure personnel suits ventilated by a life-support system.

### ***Secondary Barriers***

There are two models for BSL-4 laboratories:

- the **cabinet laboratory**, where all handling of the agent is performed in a Class III biological safety cabinet, and
- the **suit laboratory**, where personnel wear a protective suit.

### **Cabinet Laboratory**

BSL-4 laboratories may be based on either model or a combination of both models in the same facility. If a combination is used, each type must meet all the requirements identified for that type.

- Daily inspections of all containment parameters (e.g., directional airflow) and life support systems are completed before laboratory work is initiated to ensure the laboratory is operating according to its operating parameters.
- Walls, floors, and ceilings of the cabinet room and inner change room are constructed to form a sealed internal shell that facilitates fumigation and is resistant to entry and exit of animals and insects.
  - Floors are integrally sealed and coved.
  - The shell's internal surfaces are resistant to liquids and chemicals to facilitate the area's cleaning and decontamination. All penetrations in these structures and surfaces are sealed.
  - Openings around doors into the cabinet room and inner change room are minimized and are capable of being sealed to facilitate decontamination.

- Any windows are breakage-resistant and sealed.
  - Any drains in the cabinet room floor are connected directly to the liquid waste decontamination system.
  - Sewer vents and other service lines contain filters and protection against vermin.
- Bench tops have seamless or sealed surfaces that are impervious to water and are resistant to moderate heat and the organic solvents, acids, alkalis, and chemicals used to decontaminate work surfaces and equipment.
  - Laboratory furniture is of simple, open construction, capable of supporting anticipated loading and uses.
    - Spaces between benches, cabinets, and equipment are accessible for cleaning and decontamination.
    - Chairs and other furniture used in laboratory work should be covered with a non-fabric material that can be easily decontaminated.
  - A hands-free or automatically operated handwashing sink is provided near the door of the cabinet room(s) and the outer and inner change rooms.
  - Double-door autoclaves are provided for decontaminating materials passing out of both the Class III biological safety cabinet(s) and the cabinet room(s).
  - Autoclaves that open outside of the containment barrier must be sealed to the wall of the containment barrier. The autoclave doors are automatically controlled so that the outside door can only be opened after the autoclave “sterilization” cycle has been completed.
  - Pass-through dunk tanks, fumigation chambers, or equivalent decontamination methods are provided so that materials and equipment that cannot be decontaminated in the autoclave can be safely removed from both the Class III biological safety cabinet(s) and the cabinet room(s).
  - The facility must be tested for verification that the design and operational parameters have been met prior to operation. Facilities should be re-verified annually against these.

### **Suit Laboratory**

- The BSL-4 facility consists of either a separate building or a clearly demarcated and isolated zone within a building.
- The rooms in the facility are arranged to ensure passage through the changing and decontamination areas prior to entering the room(s) where work is done with BSL-4 agents (suit area).
- Outer and inner change rooms, separated by a shower, are provided for personnel entering and leaving the suit area. A specially designed suit area is maintained in the facility to provide personnel protection equivalent to that provided by Class III biological safety cabinets.
- Personnel who enter this area wear a one-piece positive pressure suit that is ventilated by a life-support system protected by HEPA filtration.
- The life-support system includes redundant breathing air compressors, alarms, and emergency backup breathing air tanks. Entry to this area is through an airlock fitted with airtight doors.
- A chemical shower is provided to decontaminate the surface of the suit before the worker leaves the area.

- An automatically starting emergency power source is provided, at a minimum, for the exhaust system, life-support systems, alarms, lighting, entry and exit controls, and biological safety cabinets.
- The air pressure within the suit is positive to the surrounding laboratory. The air pressure within the suit area is lower than that of any adjacent area.
- Emergency lighting and communication systems are provided. All penetrations into the internal shell of the suit area, chemical shower, and airlocks are sealed.
- A daily inspection of all containment parameters (e.g., directional airflow, chemical showers) and life-support systems is completed before laboratory work is initiated to ensure that the laboratory is operating according to its operating parameters.
- A double-door autoclave is provided at the containment barrier for decontaminating waste materials to be removed from the suit area. The autoclave door, which opens to the area external to the suit area, is sealed to the outer wall of the suit area and is automatically controlled so that the outside door can be opened only after the autoclave “sterilization” cycle. A dunk tank, fumigation chamber, or ventilated airlock for decontamination is provided for passage of materials, supplies, or equipment that is not brought into the suit area through the change room. These devices can be also used for the safe removal of materials, supplies, or equipment from the laboratory that cannot be decontaminated in the autoclave.
- The suit area’s walls, floors, and ceilings are constructed to form a sealed internal shell.
- The shell’s internal surfaces are resistant to liquids and chemicals, facilitating the area’s cleaning and decontamination. All penetrations in these structures and surfaces are sealed.
- Any drains in the floor of the suit area contain traps filled with a chemical disinfectant of demonstrated efficacy against the target agent, and they are connected directly to the liquid waste decontamination system.
- Sewer vents and other service lines contain filters.
- Internal facility appurtenances in the suit area, such as light fixtures, air ducts, and utility pipes, are arranged to minimize the horizontal surface area.
- Bench tops have seamless surfaces that are impervious to water and resistant to moderate heat and the organic solvents, acids, alkalis, and chemicals used to decontaminate the work surfaces and equipment.
- Laboratory furniture is of simple, open construction capable of supporting anticipated loading and uses.
- Non-porous materials are preferable.
- Spaces between benches, cabinets, and equipment are accessible for cleaning and decontamination.
- Chairs and other furniture used in laboratory work should be covered with a non-fabric material that can be easily decontaminated.
- A hands-free or automatically operated handwashing sink is provided in the suit area(s); handwashing sinks in the outer and inner change rooms should be considered based on the risk assessment.
- Any windows are breakage-resistant and are sealed.
- Liquid effluents from sinks, floor drains (if used), autoclave chambers, and other sources within the containment barrier are decontaminated by a proven method, preferably heat treatment, before being discharged to the sanitary sewer.
- A dedicated, non-recirculating ventilation system is provided. The system’s supply and exhaust components are balanced to ensure directional airflow from the area of least hazard to the area(s) of greatest potential hazard.
- Redundant supply fans are recommended, and redundant exhaust fans are required. The differential pressure/directional airflow between adjacent areas is monitored and alarmed to indicate a system

malfunction. An appropriate visual pressure monitoring device that indicates and confirms the pressure differential of the suit area must be provided and located at the entry to the clean change room. The airflow in the supply and exhaust components is monitored, and an HVAC control system is installed to prevent positive pressurization of the laboratory.

- The supply air to the suit area, decontamination shower, and decontamination airlock is protected by passage through a HEPA filter. The general room exhausts air from the suit area, decontamination shower, and decontamination airlock, and the air is treated by a passage through two HEPA filters in series prior to discharge to the outside.
- The air is discharged away from occupied spaces and air intakes. The HEPA filters are located as near as practicable to the source in order to minimize the length of potentially contaminated ductwork. All HEPA filters need to be tested and certified annually.
- The HEPA filter housings are designed to allow for *in situ* decontamination of the filter prior to removal. Alternatively, the filter can be removed in a sealed, gas-tight primary container for subsequent decontamination and/or destruction by incineration. Design of the HEPA filter housing should facilitate validation of the filter installation. The use of pre-certified HEPA filters can be an advantage. The service life of the exhaust HEPA filters can be extended through adequate pre-filtration of the supply air.
- The positioning of the supply and exhaust points should be such that dead air space in the suit room is minimized.
- The treated exhaust air from Class II biological safety cabinets, located in a facility where workers wear positive pressure suits, may be discharged into the room environment or to the outside through the facility air exhaust system. If the treated exhaust is discharged to the outside through the facility exhaust system, it is connected to this system in a manner that avoids any interference with the air balance of the cabinets or the facility exhaust system.
- The BSL-4 facility design and operational procedures must be documented.
- The facility must be tested for verification that the design and operational parameters have been met prior to operation. Facilities should be re-verified annually against these procedures as modified by operational experience.
- Appropriate communication systems should be provided between the laboratory and the outside.

## Appendix H

### Guidelines for Work with Toxins of Biological Origin

This category of toxins is defined as any toxic substance of natural origin produced by an animal, plant, or microbe. They are non-volatile, usually not dermally active (mycotoxins are an exception), and tend to be more toxic per weight than many chemical agents.

Working with biologically-derived toxins may present health risks due to routes of exposure that are not always taken into consideration. The laboratory facilities, equipment, and procedures for work with toxins must reflect the intrinsic level of hazard posed by a particular toxin, as well as the potential risks inherent in the operations being performed. The IBC will evaluate all such uses and determine if the proposed safeguards are adequate or not.

**Note:** *Toxins listed in the select agents rule must be below the excluded amounts if they are to remain exempt from the regulations. Otherwise they are subject to the full select agent rules.*

The following information is taken from the CDC/NIH's *Biosafety in Microbiological and Biomedical Laboratories* (BMBL) (5<sup>th</sup> Edition, 2007). Biosafety guidelines are intended to provide general safety requirements for the use of such toxins.

#### **General Information**

The laboratory facilities, equipment, and procedures appropriate for work with toxins of biological origin must reflect the intrinsic level of hazard posed by a particular toxin, as well as the potential risks inherent in the operations performed. If both toxins and infectious agents are used, both must be considered when containment equipment is selected and policies and procedures are written. If animals are used, animal safety practices must also be considered.

#### **Standard Practices**

- Provide all laboratory personnel with training specific for the toxins being used.
- Maintain an accurate inventory.
- Store toxin stocks in locked storage rooms, cabinets, or freezers.
- Prepare primary containers of toxin solutions and handle primary containers of dry forms of toxins in a chemical fume hood, a glove box, or a biological safety cabinet or equivalent containment system. Whenever possible, reconstitute entire vial of powdered toxin by injecting diluent through septum.
- Glove selection
  - If powdered toxin must be handled, select gloves that do not generate static electricity. Do not use latex.
  - When handling toxins that are percutaneous hazards (irritants, necrotic to tissue, or extremely toxic from dermal exposure), select gloves that are known to be impervious to the toxin.

- In addition, standard practices listed under BSL-2 and/or BSL-3 should be reviewed and incorporated as appropriate into protocols for work with toxins.

### ***Special Practices***

Specific special practices will depend on a number of parameters, such as the toxin used or the type of operations performed. In general:

- Each laboratory should develop a chemical hygiene plan specific to the toxin(s) used in that laboratory. The chemical hygiene plan should:
  - Identify the hazards that will be encountered in normal use of the toxin and those that could be encountered in case of a spill or other accident, and
  - Specify the policies and practices to be used to minimize risks (e.g., containment and personal protective equipment, management of spills, management of accidental exposures, medical surveillance).
- Training specific to the toxin(s) used should be required and documented for all laboratory personnel working with toxins, before starting work with the toxin, and at intervals thereafter.
- An inventory control system should be in place.
- Toxins should be stored in locked storage rooms, cabinets, or freezers when not in use.
- Access to areas containing toxins should be restricted to those whose work assignments require access.
- Preparation of primary containers of toxin stock solutions and manipulations of primary containers of dry forms of toxins should be conducted in a chemical fume hood, a glove box, or a biological safety cabinet or equivalent containment system approved by the safety officer. HEPA and/or charcoal filtration of the exhaust air may be required, depending on the toxin.
- The user should verify inward airflow of the hood or biological safety cabinet before initiating work.
- All work should be done within the operationally effective zone of the hood or biological safety cabinet.
- When toxins are in use, the room should be posted to indicate “Toxins in Use - Authorized Personnel Only.” Any special entry requirements should be posted on the room’s entrance(s). Only personnel whose presence is required should be permitted in the room while toxins are in use.
- All high-risk operations should be conducted with two knowledgeable individuals present. Each must be familiar with the applicable procedures, maintain visual contact with the other, and be

ready to assist in the event of an accident.

- Before containers are removed from the hood, cabinet, or glove box, the exterior of the closed primary container should be decontaminated and placed in a clean secondary container. Toxins should be transported only in leak-/spill-proof secondary containers.
- Contaminated and potentially contaminated protective clothing and equipment should be decontaminated using methods known to be effective against the toxin before removal from the laboratory for disposal, cleaning, or repair. If decontamination is not possible/practical, materials (e.g., used gloves) should be disposed of as toxic waste. Materials contaminated with infectious agents, as well as toxins, should also be autoclaved or otherwise rendered non-infectious before leaving the laboratory.
- The interior of the hood, glove box, or cabinet should be decontaminated periodically, for example, at the end of a series of related experiments. Until decontaminated, the hood, box, or cabinet should be posted to indicate that toxins are in use, and access to the equipment and apparatus restricted to necessary, authorized personnel.

### ***Safety Equipment***

The IBC will review each protocol and determine the specific safety requirements. In general, toxins are expected to meet all BSL-2 requirements and, in some instances, might require BSL-3 level safety equipment.

- When using an open-fronted fume hood or biological safety cabinet, protective clothing, including gloves and a disposable, long-sleeved body covering (gown, laboratory coat, smock, coverall, or similar garment) should be worn so that hands and arms are completely covered.
- Eye protection should be worn if an open-fronted containment system is used.
- Other protective equipment may be required, depending on the characteristics of the toxin and the containment system. For example, use additional respiratory protection if aerosols may be generated and it is not possible to use containment equipment or other engineering controls.
- When handling dry forms of toxins that are electrostatic:
  - Do not wear gloves (such as latex) that help to generate static electricity.
  - Use a glove bag within a hood or biological safety cabinet, a glove box, or a Class III biological safety cabinet.
- When handling toxins that are percutaneous hazards (irritants, necrotic to tissue, or extremely toxic from dermal exposure), select gloves that are known to be impervious to the toxin.
- Consider both toxin and diluents when selecting gloves and other protective clothing.
- If infectious agents and toxins are used together in an experimental system, consider both when selecting protective clothing and equipment.



### ***Laboratory Facilities***

Laboratory facility recommendations listed under BSL-2 and BSL-3, as well as OSHA standards, should be reviewed and incorporated as appropriate into protocols for work with toxins.

- When vacuum lines are used with systems containing toxins, they should be protected with a HEPA filter to prevent entry of toxins into the lines. Sink drains should be similarly protected when water aspirators are used.

### ***Receiving, Inspecting, Storage and Distribution of Samples/Materials***

The laboratory must develop specific standard operating procedures (SOP) that addresses safety receipt, inspection, storage, usage and disposal of the toxin used. IBC requires that all SOP developed incorporate the safety and personal protective equipment into the procedures.

## Appendix I

### Prion Research/Creutzfeldt-Jacob Disease (CJD) Guidelines

Creutzfeldt-Jacob Disease (CJD) is one of a group of diseases called *transmissible spongiform encephalopathies* that also includes kuru and Gerstmann-Sträussler-Scheinker syndrome of humans, scrapie of sheep, and “mad cow disease” of cattle and dairy cows. Long (months to years) incubation periods precede the onset of clinical illness, with chronic progressive pathology that may last weeks to months. CJD is characterized by progressive dementia, myoclonic fasciculations, ataxia, and somnolence. The clinical course of CJD usually lasts several months and is invariably fatal. No effective treatment is available, and there are no known cases of remissions or recoveries.

Transmissible spongiform encephalopathies are caused by a unique infectious agent called a prion, composed of a proteinaceous material devoid of detectable amounts of nucleic acid. Prions are unusually resistant to standard means of inactivation, including formaldehyde, ethanol, and UV radiation. However, they can be inactivated by fresh household bleach; 1.0N sodium hydroxide (NaOH); 4.0N guanidine reagents; phenol; and autoclaving. Procedures involving brain tissue from patients with neurological degenerative disorders (such as CJD and Alzheimer’s disease) pose special challenges in reducing potential exposure to prions; such material should be handled with at least the same precautions as HIV-positive or HBV-positive human tissue.

The CDC classifies prions as Risk Group 2 agents requiring Biosafety Level 2 (BSL-2) containment. BU/BMC require all researchers working with these agents to have a valid Biological Use Approval; IBC approval must be granted before any research can be initiated.

The following current BU/BMC prion procedures have evolved from best practices used at many institutions, including the University of California, San Francisco and the University of California, San Diego, that have been engaged in such research for years.

**Note:** *Work with bovine spongiform encephalopathy falls under the select agents rule.*

#### **Safety Procedures**

- All fixed, non-fixed, or frozen tissues must be contained within watertight containers and labeled with the universal biohazard symbol and the notation “Infectious Materials.”
- All tissues, infectious waste, and instruments (e.g., specimen containers, knives, blades, cutting boards, and centrifuge tubes) used in the processing of such samples must be decontaminated by 1N NaOH or undiluted fresh household bleach (5.25% sodium hypochlorite) and autoclaving at 132° C for 4.5 hours (see *Prion Decontamination Procedures* for instructions).
- Personnel must wear gloves and gowns while handling tissues that are potentially contaminated. All protective clothing must be removed before leaving the laboratory.
- Sonication or homogenization of tissues must be performed in a properly certified Class II biological safety cabinet.

- Microtome blades and knives used for cutting tissue must be cleaned with an instrument that does not put the operator's hand or finger in or near contact with the blade.
- Any skin contact with possibly infectious materials should be followed by washing with 1N sodium hydroxide for two to three minutes, followed by extensive washing with water.
- The PI must contact the Biosafety Officer in writing regarding spills and accidents that result in overt exposure to tissues. The report must include the following:
  - Specification of amount released, time involved, and explanation of procedures used to determine the amount involved.
  - Description of the area involved and the extent of employee exposure.
  - Report of medical treatment provided.
  - Corrective action taken to prevent the reoccurrence of the incident.

### ***Records***

- The PI must maintain health records for a period of 30 years.
  - Upon death, retirement or other termination of the employee's employment or in the event the employer ceases to do business with a successor, records or notarized true copies must be forwarded to the Director of National Institute of Occupational Safety and Health (NIOSH).
- Records must be provided upon request by representatives of the Chief and/or Director of NIOSH.
- Any physician who conducts a medical examination must furnish the employer a statement of the employee's suitability for employment.
- Access to the laboratory must be restricted to trained personnel when work is being conducted on tissue.
- Personnel handling tissue must be trained in the following:
  - Nature of CJD
  - Route of transmission of CJD
  - Specific hazards associated with handling of the tissue.

### ***Prion Decontamination Procedures***

- Contaminated liquids are disinfected by making 1.0N sodium hydroxide (NaOH) followed by autoclaving at 132° C for 4.5 hours. Alternatively (if an autoclave that can reach that temperature isn't available), the 1.0N NaOH-treated liquid can be held at room temperature for 24 hours. Liquids treated in either of these ways can then be poured down the sink.

- Contaminated surfaces that can withstand the treatment are cleaned with 1.0N NaOH, allowing 5 minutes of contact time, followed by wipe-down with 1.0N HCl, then thorough washing with clear water.
- Contaminated surfaces that cannot withstand NaOH/HCl treatment are cleaned with 10% household bleach, allowing 10-15 minutes contact time, then washed with clear water.
- Contaminated skin surfaces are washed with 1.0N NaOH or 10% bleach for 2-3 minutes, followed by rinsing with copious amounts of water. Splashes to the eye are rinsed with copious amounts of water or saline.
- Contaminated dry waste is autoclaved at 132° C for 4.5 hours then discarded as solid waste (trash).
- Sharps waste is autoclaved at 132° C for 4.5 hours before being picked up as medical waste for incineration.

*Note: This is a departure from the BU policy of not autoclaving sharps but is acceptable in this case because of the elevated risks associated with prion exposure.*

## Appendix J

### Summary of Requirements for Biosafety Levels

Safety Guideline	BSL1	BSL2	BSL3	BSL4
Laboratory personnel must wash their hands after handling cultures, removing gloves, and before leaving the laboratory.	Y	Y	Y	Y
Eating, drinking, and application of cosmetics is prohibited.	Y	Y	Y	Y
Personnel must be familiar with basic biosafety procedures, including this manual.	Y	Y	Y	Y
Personnel should wear goggles or face shields if the possibility of splashes and aerosols exists.	Y	Y	Y	Y
Pipetting by mouth is prohibited.	Y	Y	Y	Y
All laboratory procedures should be performed to minimize aerosol generation.	Y	Y	Y	Y
Work surfaces must be decontaminated at least daily, after each use for infrequent users, and after any spill of viable materials.	Y	Y	Y	Y
Sharps must be placed in specially designed puncture- and leak-proof sharps containers and disposed of appropriately as medical waste.	Y	Y	Y	Y
Laboratories must be kept neat; good housekeeping procedures must be in place and in regular use.	Y	Y	Y	Y
All medical waste is decontaminated before disposal by an approved decontamination method or disposed of as medical waste.	Y	Y	Y	Y
Insect and rodent control programs are instituted.	Y	Y	Y	Y
Laboratory contains a sink for handwashing.	Y	Y	Y	Y
Laboratories are designed for ease of decontamination (e.g., no carpets, sealed surfaces, no unreachable areas, etc.).	Y	Y	Y	Y
Bench tops are impervious to water, moderate heat, and chemicals.	Y	Y	Y	Y
Laboratory furniture must be secured, and spaces between benches, cabinets, and equipment must be accessible for decontamination.	Y	Y	Y	Y
All laboratory windows must be fitted with fly screens.	Y	Y	Y	Y
Laboratory coats or gowns and gloves must be worn.	Y	Y	Y	Y

Autoclaves are required for waste treatment prior to disposal as non-biohazardous waste.	N	N	Y	Y
Autoclave quality control program is required for use specified above.	Y	Y	Y	Y
Instructions for safety precautions are posted by the Principal Investigator.	Y	Y	Y	Y
Animals not involved in the experiment are not permitted in laboratory.	N	Y	Y	Y
Biological safety cabinets are required and must be certified annually.	N	Y	Y	Y
Laboratory personnel require specific training in the handling of pathogenic materials.	N	Y	Y	Y
Safety centrifuge cups are required.	N	Y	Y	Y
Access to facility is limited or restricted during experiments.	N	Y	Y	Y
The universal biohazard symbol must be posted on the access door to the laboratory.	N	Y	Y	Y
Immunization and/or serological testing for agents to be handled may be required.	N	Y	Y	Y
All laboratory procedures must be performed in a properly certified biological safety cabinet.	N	N	Y	Y
Laboratory requires controlled entry, unidirectional air flow, and other special design features.	N	N	Y	Y
Windows must be closed and sealed.	N	N	Y	Y
No material or equipment can leave the laboratory unless it is autoclaved or decontaminated.	N	N	Y	Y
Autoclaves must be located inside the laboratory.	N	N	Y	Y
Access is through an airlock system.	N	N	N	Y

## Appendix K

### Summary of Requirements for Animal Biosafety Levels

Safety Guideline	BSL1	BSL2	BSL3	BSL4
Access is limited or restricted at the discretion of the laboratory or Animal Care Facility Director.	Y	Y	Y	Y
Personnel must wash their hands after handling cultures and animals, removing gloves, and before leaving the facility.	Y	Y	Y	Y
Eating, drinking, and application of cosmetics is prohibited.	Y	Y	Y	Y
Personnel must be familiar with basic biosafety procedures, including this manual.	Y	Y	Y	Y
Personnel should wear goggles or face shields if the possibility of splashes and aerosols exists.	Y	Y	Y	Y
Pipetting by mouth is prohibited.	Y	Y	Y	Y
All procedures should be performed to minimize aerosol generation.	Y	Y	Y	Y
Work surfaces must be decontaminated at least daily, after each use for infrequent users, and after any spill of viable materials.	Y	Y	Y	Y
Sharps must be placed in specially designed puncture- and leak-proof sharps containers and disposed of appropriately as medical waste.	Y	Y	Y	Y
Facilities must be kept neat; good housekeeping procedures must be in place and in regular use.	Y	Y	Y	Y
All medical waste is decontaminated before disposal by an approved decontamination method or disposed of as medical waste.	Y	Y	Y	Y
Insect and rodent control programs are instituted.	Y	Y	Y	Y
Doors to animal rooms are kept closed when experimental animals are present.	Y	Y	Y	Y
Facilities are designed for ease of decontamination (e.g., no carpets, sealed surfaces, no unreachable areas, etc.).	Y	Y	Y	Y
Bedding materials from animal cages are removed in a manner that minimizes aerosol production and are disposed of as medical waste.	Y	Y	Y	Y
Instructions for safety precautions are posted by the Principal Investigator.	Y	Y	Y	Y

Facility windows that open must be fitted with fly screens.	Y	Y	Y	Y
Laboratory coats or gowns and gloves must be worn.	Y	Y	Y	Y
Autoclaves are required for waste treatment prior to disposal as non-biohazardous waste.	Y	Y	Y	Y
Autoclave quality control program is required for use specified above.	Y	Y	Y	Y
Cages are washed prior to release or reuse.	Y	Y	Y	Y
Air is exhausted to the outside without recirculation.	N	Y	Y	Y
Personnel baseline serum samples may be required.	N	Y	Y	Y
Facility personnel require specific training in the handling of pathogenic materials.	N	Y	Y	Y
Safety centrifuge cups are required.	N	Y	Y	Y
Access to facility is limited or restricted during experiments.	N	Y	Y	Y
The universal biohazard symbol must be posted on the access door to the facility.	N	Y	Y	Y
Immunization and/or serological testing for agents to be handled may be required.	N	Y	Y	Y
All procedures must be performed in a properly certified biological safety cabinet.	N	N	Y	Y
Facility requires controlled entry, unidirectional air flow, and other special design features.	N	N	Y	Y
Windows must be closed and sealed.	N	N	Y	Y
No material or equipment can leave the facility unless it is autoclaved or decontaminated.	N	N	Y	Y
Autoclaves must be located inside the facility.	N	N	Y	Y
Access is through an airlock system.	N	N	N	Y



## Appendix L

### Bloodborne Pathogen Standard

Hepatitis B viral infection is one of the most frequent laboratory-associated infections, and laboratory personnel are recognized as a high-risk group for acquiring this infection (Centers for Disease Control and Prevention). Avoiding occupational exposure to human blood, body fluids, and tissues is the primary way to prevent transmission of bloodborne pathogens. The goal of the initial and annual standard precautions training is to present information on how to prevent such exposures by administrative controls, workplace engineering controls, proper work practices, personal protective equipment, and a hepatitis B vaccine immunization program.

Personnel can be exposed to bloodborne pathogens by being stuck with contaminated needles, lacerations from contaminated sharp instruments, or being splashed with blood or body fluids on the mucous membrane of the eye, nose or mouth, or on abraded, non-intact skin (i.e., chapped skin or skin affected by dermatitis). Any direct contact (i.e., contact without barrier protection) to concentrated hepatitis B, hepatitis C, HIV, or any other infectious virus in a research laboratory or production facility is considered an exposure that requires clinical evaluation. All employees working with human cell cultures should be offered hepatitis B vaccination and be evaluated if an exposure occurs.

The OSHA Bloodborne Pathogens Standard applies to all employees who might come into contact with blood or other bodily fluids, including:

- Human blood
- Human blood components
- Products made from human blood, or other potentially infectious materials (OPIM) such as the following human body fluids:
  - Semen
  - Vaginal secretions
  - Cerebrospinal fluid
  - Synovial fluid
  - Peritoneal fluid
  - Amniotic fluid
  - Saliva in dental procedures
  - Body fluid that is visibly contaminated with blood, and all body fluids in situations where it is difficult or impossible to differentiate between body fluids.
- Any unfixed tissue or organ (other than intact skin) from human (living or dead)
- HIV-containing cell or tissue cultures, organ cultures, and HIV-, HBV- or HCV-containing culture medium or other solutions; and blood, organs, or other tissues from experimental animals with HIV, HBV or HCV.

#### *Program Elements*

The Bloodborne Pathogens Standard requires that an Exposure Control Plan be written and implemented. The Exposure Control Plan must have the following elements:

- Policies and procedures for elimination, or minimization, of exposure
- Evaluation of employee exposure potentials
- Medical surveillance program
- Routine training

*The following is a general outline of the BU Exposure Control Plan.*

### ***Roles and Responsibilities***

- The PI/laboratory director/employee supervisor must identify employees under his or her supervision who may be at risk.
- Upon identifying these employees, the supervisor must
  - Reduce potential risk by providing personal protective clothing and equipment.
  - Provide HBV vaccinations at no cost to the employee.
  - Train the employees.
  - Develop an effective hazard communication program.
  - Ensure engineering controls, such as a biological safety cabinet or sharps container.
  - Develop safe work practices and procedures, as well as internal notification procedures to report accidents.
  - In conjunction with the academic department, review the list of at-risk employees on an annual basis to ensure that the list is current.

### ***Key Definitions***

- **Other potentially infectious materials (OPIM)** are those listed in Appendix L.
- **Regulated waste** means liquid or semi-liquid blood or other potentially infectious materials and contaminated items that would release blood or other potentially infectious material in a liquid or semi-liquid state if compressed; items that are caked with dried blood or other potentially infectious materials and are capable of releasing these materials during handling; contaminated sharps; and pathological and microbiological wastes containing blood or other potentially infectious materials.
- **Sharps waste** means any device having acute rigid corners, edges, or protuberances capable of cutting or piercing, including, but not limited to, all of the following:
  - **Hypodermic needles**, syringes, blades, and needles with attached tubing
  - **Broken glass** items, such as Pasteur pipettes and blood vials contaminated with other medical waste

### ***At-Risk Employee Identification***

The Exposure Control Plan requires each employer to identify, in writing, all tasks, procedures, and job classifications where occupational exposure to blood may occur and to document the methods of compliance

that will minimize the potential of occupational exposure.

### ***Incident Reporting***

All incidents must be documented and a copy be kept in the laboratory and a copy forwarded to OEHS. Accident response procedures are described in Chapter 8.

### ***Written Policies and Procedures***

This manual is intended to act as a primary source of policies and procedures designed to eliminate, or minimize, potential employee exposure to all biological materials, regardless of their hazard level. Employees are required to read and implement all sections of this manual that are relevant to their work environment, and be fully familiar with universal precautions. Each PI must further develop site-specific SOP to address local programmatic needs.

### ***Medical Surveillance***

The OSHA Bloodborne Pathogens Standard requires that all personnel with potential exposure to bloodborne pathogens be offered immunization against the hepatitis B virus.

- HBV vaccinations must be offered to an employee within 10 days of assignment.
- Personnel must indicate their acceptance or declination on the Hepatitis B Vaccine Compliance Form; the PI must retain this form on file for the duration of the employee's employment plus thirty (30) years.
- An employee who declines hepatitis B vaccination may, at any time thereafter, change his or her mind and receive the vaccine. The acceptance statement must be signed at that time.
- The PI/laboratory supervisor must not make participation in a prescreening program a prerequisite for receiving the vaccination.
- The HBV vaccination is available at no cost to the employee.

BPHC must also be notified of all presumptive exposures (See Appendix T for BPHC Medical Surveillance Reporting requirements).

### ***Training Requirements***

- The PI must ensure that all employees with the potential for occupational exposure participate in a training program provided by OEHS at no cost to the employee during working hours.
- Training must be given in accordance with the Bloodborne Pathogens Standard upon initial assignment, on an annual basis thereafter, or whenever modification of an existing job description may affect the employee's potential for occupational exposure.
- HIV/HBV research laboratories must ensure that their employees demonstrate proficiency in standard microbiological procedures prior to being allowed to work in the laboratory.

- Training must include a comprehensive discussion of this standard, including epidemiology, symptoms and transmission of bloodborne diseases; the Exposure Control Plan; the uses, limitations of, and procedures for using personal protective equipment; a discussion of the HBV vaccination (including the benefits of vaccination and efficiency of the vaccine to prevent disease); emergency procedures involving blood exposure or contamination and post-exposure follow-up procedures; hazard communication; and a question-and-answer discussion opportunity.

OEHS provides Bloodborne Pathogens training on a regularly scheduled basis. For more information and scheduling, call (617) 638-4236.

### ***PI Responsibilities for Occupational Health Issues***

In keeping with the OSHA Bloodborne Pathogen Standard, this policy requires annual standard precautions training, a hepatitis B immunization program, and a post-exposure medical management program.

It is the PI's responsibility to ensure that researchers, technicians, students, or volunteers who work in the laboratory and who have contact with animals, infectious agents, or bloodborne pathogens are medically evaluated prior to starting work and that anyone working with bloodborne pathogens is offered the hepatitis B vaccination series administered by Occupational Health Services in compliance with the Bloodborne Pathogen Exposure Policy for Boston University/Boston Medical Center.

An appointment can be made with a medical provider by calling BMC's Occupational & Environmental Medicine Department, 732 Harrison Avenue, Preston Building (F5), (617) 638-8400, or BU's Occupational Health Center at the Charles River Campus, 930 Commonwealth Avenue, West, 1<sup>st</sup> Floor, Pleasant Street entrance, (617) 353-6630.

If the research project is located at a facility at another institution, such as the VA Hospital or the Framingham Heart Study, occupational health services should be available on-site at that institution. If these services are not available on-site, please contact Occupational Health Services at (617) 353-6630 for assistance in arranging access to appropriate services.

It is the PI's responsibility to ensure that:

- Any person present in a BU laboratory who has an incident involving potential exposure to an infectious agent is offered ***immediate*** access to a medical evaluation at Occupational Health Services (listed below) or the BMC Emergency Department (after hours, holidays, and weekends). An immediate evaluation is important, as efficacy of post-exposure medication for HIV and other infectious agents may be less effective if the initiation of treatment is delayed.
- Personnel working with non-human primates or their tissues have a physical examination, an evaluation for tuberculosis, and an immunization screen. Additionally, such individuals must provide serum for banking prior to commencing work with these animals, be informed about the risks and preventive services available, and wear appropriate personal protective equipment.

- When required, each individual completes a medical clearance for respirator use prior to fit-testing for a respirator.
- Personnel who develop symptoms of allergy or asthma that occur upon exposure to experimental animals are referred to Occupational Health Services for evaluation.

Under the OSHA Bloodborne Pathogen Standard, BU and BMC are required to offer the hepatitis B vaccine to all employees at risk within 10 days of starting their work assignment. Employees must be informed of the vaccine's benefits and risks, and if they choose not to receive it at the initial evaluation time, they must sign a declination form. If the employee has had the vaccine previously, but has not had a blood antibody titer to confirm his or her immunity in the past, the employee will be offered the opportunity to have a titer drawn. An employee who declines the vaccine may at any time elect to have the vaccine if his or her job tasks or work setting continue to have the risk of potential exposure to bloodborne pathogens.

If, during research, any employee has an exposure to bloodborne pathogens, he or she **MUST** report immediately to Occupational Health Services during regular business hours or to the BMC East Newton Campus Emergency Department, (617) 638-6240, after hours, on holidays, or weekends. An immediate evaluation is important, as efficacy of post-exposure medication for HIV may be less effective if the initiation of treatment is delayed. For more information, call BU's Occupational Health Center at the Charles River Campus at (617) 353-6630.

### ***Contacting Occupational Health Services***

**On Boston University Medical Campus/Boston Medical Center**, Occupational & Environmental Medicine (Occupational Health) is open 7:30 a.m. to 4:00 p.m., Monday through Friday, except for BMC holidays. Report to the Preston Family Building (F5), 732 Harrison Avenue, 5<sup>th</sup> floor. They may be reached at (617) 638-8400.

**On the Charles River Campus**, Boston University Occupational Health Center is open 9:00 a.m. to 5:00 p.m. at 930 Commonwealth Avenue, West, 1<sup>st</sup> Floor, Pleasant Street entrance. They may be reached at (617) 353-6630 or at (617) 638-8410.

**BMC East Newton Campus Emergency Department** is available after hours, on holidays, and during weekends. The department may be reached at (617) 638-6240.

Questions may be directed to:

CRC: Occupational Health Center: (617) 353-6630  
BUMC: Boston Medical Center: (617) 638-8410

### **REFERENCES:**

OSHA Bloodborne Pathogen Program:

BUMC  
Biosafety Manual  
Revised Document  
October 12, 2007

[http://www.osha.gov/pls/oshaweb/owadisp.show\\_document?p\\_table=STANDARDS&p\\_id=10051](http://www.osha.gov/pls/oshaweb/owadisp.show_document?p_table=STANDARDS&p_id=10051)

Centers for Disease Control and Prevention/National Institutes of Health: *Biosafety in Microbiological and Biomedical Laboratories*, U.S. Department of Health and Human Services, 5<sup>th</sup> edition, February 2007.  
<http://www.cdc.gov/od/ohs/biosfty/bmbl4/bmbl4toc.htm>

CDC: “Updated U.S. Public Health Service Guidelines for the Management of Occupational Exposures to HBV, HCV, and HIV and Recommendations for Post-exposure Prophylaxis,”  
*Morbidity and Mortality Weekly Report*, June 29, 2001/Vol. 50/ No. RR-11.  
<http://www.cdc.gov/mmwr/PDF/rr/rr5011.pdf>

Institute of Laboratory Research (ILAR): *Occupational Health in the Care and Use of Research Animals*, National Academy Press, 1997. <http://www.nap.edu/books/0309052998/html/index.html>

U.S. Department of Labor/OSHA: “Bloodborne Pathogens and Needlestick Prevention.”  
<http://www.osha.gov/SLTC/bloodbornepathogens/>

## Appendix M

### Working Safely with Animals

Working with animals poses potential additional health and safety hazards that require extra precautions. The specific requirements will depend on the types of activities (e.g., surgery, feeding animals, use of anesthetic agents, etc) and the specific species used. Personnel should follow the following guidelines:

- Follow the specific requirements established in the IACUC-approved protocol and the facility requirements.
- Wash hands after handling an animal or anything that an animal has touched. The most common way of contracting an animal-transmitted infection is placing the infectious material directly into the mouth.
- Never smoke, drink, or eat in an animal area or before washing hands.
- Wear protective clothing as recommended by the facility for the species and operations.
  - Do not take protective clothing home.
  - Protective clothing helps prevent potentially contaminated material from leaving an animal area.
- Use the personal protective equipment (PPE) recommended for the species and operations.
  - Workers shall wear the appropriate PPE (e.g., gloves, face shields, masks, and respirators) when required and follow their supervisor's instructions scrupulously.
- Participate in the Occupational Health Program Services that provides appropriate testing, immunizations, and periodic screening for allergies, infections, and other medical problems related to animal exposure.
  - Seek medical attention promptly when injured. Follow the specific recommendations for the facility.
  - Workers engaged in work involving vertebrate animals should inform their physician of their work when seeking treatment for illness, even if uncertain whether the illness is work related. Physicians need such information to make an accurate diagnosis because many animal-transmitted diseases have flu-like symptoms.
  - If there is any possibility of work-related illness or disease, the Occupational Health Program must be notified immediately.
- Get the appropriate training and contact a supervisor with any questions.

#### *Basic Safety for the Necropsy of Infected Animals*

- Ensure that the necropsy of infected animals is carried out in biological safety cabinets by trained personnel.
- Wear a surgeon's wrap-around gowns over laboratory clothing.
- Use a surgeon's mask and eye protection.
- Use other PPE recommended by the facility for the infectious agents present.
- Wear rubber gloves.
- Wet the fur of the animal with a suitable disinfectant.

- Pin down or otherwise fasten small animals to wood or metal in a tray.
- Before and after necropsy, disinfect the necropsy table, inside the BSC, and other potentially contaminated surfaces with a suitable germicide.
- Upon completion of necropsy, place all potential biohazardous materials in suitable containers and then sterilize the materials.
- Segregate contaminated mixed waste and store for appropriate disposal.
- Place contaminated instruments in a bath that contains a suitable disinfectant.
- Follow the facility requirements for sterilization.
- Clean contaminated rubber gloves in disinfectant before removal from the hands.
- Wearing gloves is not a substitute for handwashing; wash hands after necropsy and carcass disposal.
- Follow the facility's guidelines for the disposal of dead animals



## Appendix N

### Procedures for Working in an Animal Biosafety Level 2 (ABSL-2) Facility at BU

Before starting any Animal Biosafety Level 2 (ABSL-2) work at BU/BMC, a PI must:

- Obtain IBC and IACUC approval
- Make appropriate housing arrangements with the LASC/LACF director

The following Standard Operating Procedures (SOP) have been developed to provide guidance to those individuals working in rooms in which animals involved in chemical and biological hazards determined to be ABSL-2 are housed.

#### *Definitions*

- **ABSL-2:** Animal Biosafety Level 2 includes pathogenic agents of moderate hazard potential (CDC Biohazard Class 2) and chemical hazard agents of moderate hazard potential.
- **PPE:** Personal protective equipment
- **OEHS:** Office of Environmental Health and Safety
- **Parenteral:** Taken into the body or administered in a manner other than through the digestive tract, as by intravenous or intramuscular injection.

#### *Overview*

Access to the room where the work is to be conducted is restricted. Laboratory personnel must have training in aseptic micro-isolator techniques and use of biological safety cabinets, in addition to specific safety training in handling the pathogenic and/or chemical agent(s) with which they are working.

Research and Laboratory Animal Science Center (LASC at BUMC) and Laboratory Animal Care Facility (LACF at CRC) personnel should receive appropriate immunizations or tests for any agents handled or potentially present in the room (serum may be collected) prior to initiating the ABSL-2 portion of their project.

Procedures must be conducted in a Class II BSC.

#### *Equipment and Supplies*

- PPE: All required PPE is located on the supply cart in the corridor outside the ABSL-2 rooms.
  - Gown: Water impermeable, ties in back
  - Hair covers
  - Shoe covers
  - Mask: N95 respirator. Must be fitted by trainer for correct size (S,M,L)
  - Gloves: Use only blue nitrile gloves. Wear two layers of gloves.
  - Face shields
- Biohazard stickers for cage cards

- MB-10 (chlorine dioxide) disinfectant
- Biological safety cabinet: Class II

### ***Responsibilities***

It is the OEHS' responsibility to ensure that all necessary project-specific safety training is provided to research and LASC staff prior to any project being initiated. It also OEHS' responsibility to provide documentation to the LASC of such training.

The PI and individuals working in the facility are responsible for ensuring they have received proper training and that they are adhering to this SOP, as well as to posted precautions and guidelines in the facilities.

### ***Procedure***

- **Entry**
  - Remove the lab coat worn in the LASC facility and hang it on the garment rack provided outside of W-839/838.
  - PPE *must* be worn while working in W-838 and W-839. PPE used in W-839 is stored on racks located in the corridor just outside W-839/838. Put on ABSL-2-required PPE in the hallway outside W-839/838.
  - Proceed into the room W-839/838 using an access card.
- **Conducting a Procedure**
  - General Information
    - Investigators using the room will be assigned a cubicle and/or rack and shelf/shelves where their animals will be housed.
      - A cubicle or rack may hold cages belonging to more than one investigator.
      - Biohazard projects are not housed in cubicles that house ongoing chemical hazard projects.
    - LASC personnel will perform daily health checks of animals on studies involving infectious agents if the animals are housed on racks not held in cubicles.
      - LASC personnel will perform daily health checks of animals on studies involving chemical agents by viewing the animals through the window of the isolation cubicle.
    - The LASC will notify PIs of any animal health issues.
    - All animal work will be conducted within the confines of the Class II BSC.
      - Always open micro-isolator cages in the Class II BSC using aseptic micro-isolator technique.
    - Hypodermic needles and syringes are used only for parenteral injection or aspiration of fluids from laboratory animals and bottles with plastic/rubber diaphragms.
      - Only needle-locking syringes or disposable needle syringe units (i.e., the needle is integral to the syringe) are used for the injection or aspiration of infectious fluids.
      - Needles should not be bent, sheared, replaced in the sheath or guard, or removed from the syringe following use.

- The needle and syringe should be promptly placed in a puncture-resistant sharps container.
- Always spray or wipe down all interior surfaces of the Class II BSC with MB-10 **before** and **after** working in the hood. Allow 10 minutes of contact time prior to wiping the surfaces with disposable towels. Do not spray the top grille of the Class II BSC (this is where the filter is located). Discard used towels in the waste container.

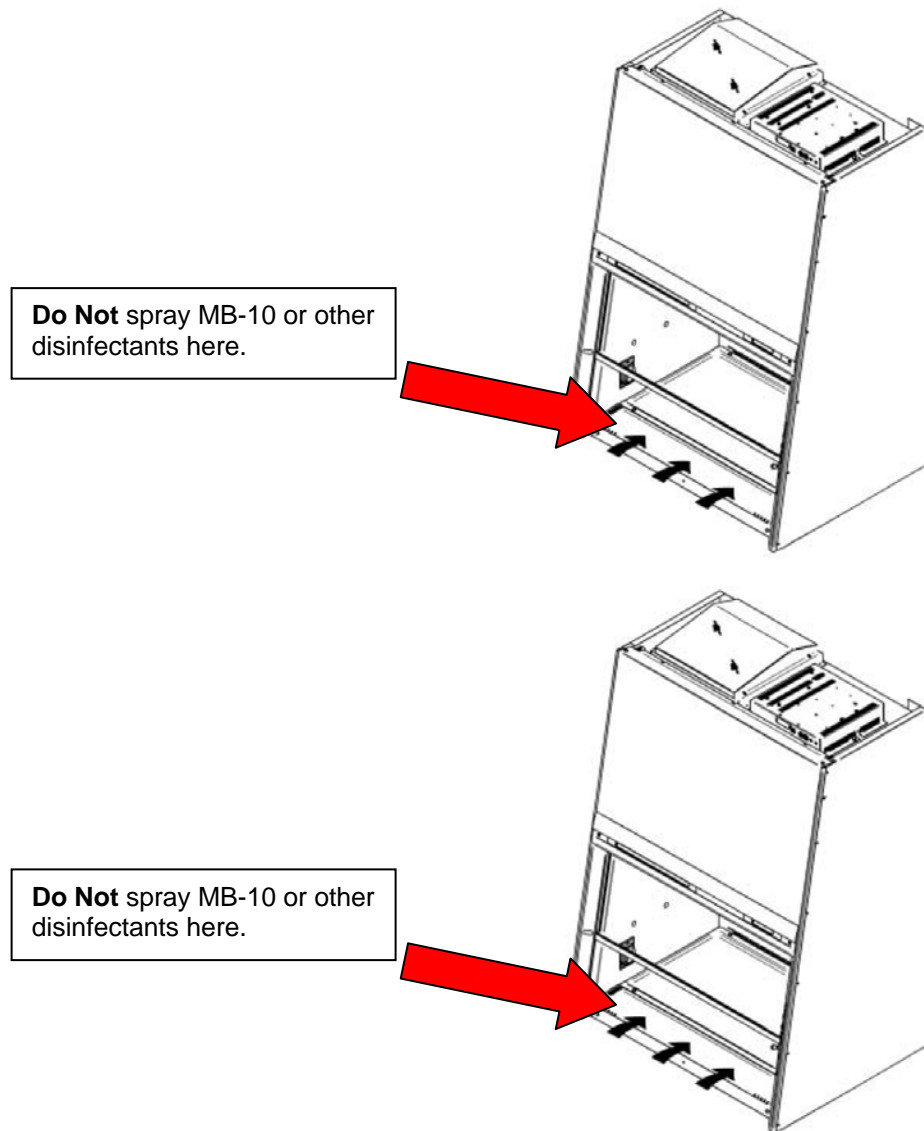

- Immediately following infection of animals with pathogenic agents, place a biohazard sticker on their cage card(s) (LASC provides these specific stickers). Fill out the following information on the biohazard sticker for cage cards:
  - PI name
  - 24-hour contact phone number
  - Protocol number
  - Pathogenic agent
  - Dose per animal
  - Date(s) infected
  - Husbandry by PI or LASC (circle one)
- Report all spills and accidents that result in overt exposure to infectious materials to a LASC Supervisor and the LASC office, (617) 638-0486.

• **Removal of Dirty Cages and Bottles from Room**

• *Biological agents*

- Place a cage inside the BSC, remove the water bottle from the cage, and replace the lid.
  - Put soiled cage, wire lid, and bedding in a semi-clear biohazard autoclave bag and place on a cart.
  - Put water bottles in a separate, semi-clear biohazard autoclave bag on a cart.
- Closure ties are stored adjacent to the biohazard autoclave bags on the supply rack in the corridor outside W-838/839 and in both rooms.
- **Do not use** autoclave tape to close the bag.
- Thoroughly spray the exterior of all bags with MB-10 after closing the bag with a nylon tie, beaded tie, or twist tie. Spray all surfaces and wheels of the cart(s).
- Cart(s) should be moved to the soiled side of the cage wash room on the 8<sup>th</sup> floor of W Building (W-8)

• *Chemical agents*

- Place a cage inside the BSC, remove the water bottle from the cage, and replace the lid.
  - Put soiled cage, wire lid, and bedding in a red biohazard bag and place on a cart.
  - Put water bottles in a separate red biohazard bag on a cart.
- Closure ties are stored adjacent to the biohazard autoclave bags on the supply rack in the corridor outside W-838/839 and in both rooms.
- **Do not use** autoclave tape to close the bag.
- Thoroughly spray the exterior of all bags with MB-10 after closing the bag with a nylon tie, beaded tie, or twist tie. Spray all surfaces and wheels of the cart(s).
- Cart(s) should be moved to the soiled side of the cage wash room on the 8<sup>th</sup> floor of W Building (W-8).

• *Disposal of carcasses*

- Any dead animals must be removed from their cage (while in the BSC) and placed in a small, leak-proof red biohazard bag.
- Place a sticker with a dead animal number on the outer bag, then thoroughly spray the bag with MB-10 and place in the refrigerator in W-839/838. A purple cage card with a sticker showing the same dead animal number will be placed on the cage.
- The LASC will remove carcasses for incineration three days after they are found in the refrigerator.

• **Exiting Procedures**

- When work is complete and the BSC and all other work spaces have been decontaminated with MB-10, outer gloves should be removed and placed in the biohazard waste container.
- To exit the room, open the door and remove one shoe cover, stepping over the room threshold into the hallway with that foot.
- Remove the shoe cover from the other foot as it is brought into the hallway but before stepping into the hallway with the second foot.
- Remove gown from the shoulders, turning it inside out.
- Discard disposable face protection, hair cover, and mask in the red biohazard trash receptacle in the hallway outside W-839/838.
- After leaving W-839/838 and discarding PPE, hands should be washed using the alcohol hand sprayer located on the wall immediately to the left of the doors to W-839/838.

*Reference: Biosafety in Microbiological and Biomedical Laboratories (5<sup>th</sup> edition, 2007)*

## Appendix O

### Policy for Verifying the Identity of Attenuated Pathogens

This policy covers all attenuated pathogens that meet the following criteria:

- The attenuated pathogen is derived from a known, virulent pathogen that requires BSL-3 or BSL-4 biosafety containment.
- Attenuation results in decreased virulence of the organism.
- Attenuation results in a reduction in the level of biosafety containment in which the attenuated pathogen can be handled, compared with the biosafety level required for the safe handling of the non-attenuated counterpart.

As is the case with all proposed studies at BU or BMC, work with any pathogen, including attenuated pathogens, cannot be initiated (and the pathogens cannot be brought into BU/BMC) without prior IBC approval.

#### *Policy*

- The identity of any attenuated pathogen must be verified before it can be handled at the lower biosafety containment level of the attenuated pathogen. Verification should be by restriction analysis or another method that has been proven to rigorously distinguish the wild-type and attenuated pathogens. Verification should be conducted on the received stock and, whenever possible, verification should be carried on an individual clone of the incoming attenuated pathogen. Only material from the verified clone (or stock) can be studied at the lower biosafety level.
- Verification should be carried out by the receiving BU laboratory pursuant to an IBC-approved protocol for verification. The attenuated pathogen must not be received at BU until after the IBC approval of the protocol for verification, including how and where the specimen will be stored upon receipt. Upon receipt of the specimen, the pathogen must be handled at the higher biosafety level of the non-attenuated, wild-type pathogen until the specimen has been verified to contain only the attenuated pathogen that can be safely handled at the lower biosafety level. Verification must be submitted to the IBC, or its designee, for review prior to transferring the attenuated pathogen to the lower containment level.
- If the identity of an attenuated pathogen cannot be verified, it must be handled at the higher biosafety level of the non-attenuated, wild-type pathogen.

Note: BPHC prohibition on work with rDNA classified as BSL-4 is in effect at BU/BMC.

## **Appendix P**

### **Boston Public Health Commission Requirements**

The Biological Laboratory Regulations adopted by the Boston Public Health Commission (BPHC) in September 2006 require laboratories at Biosafety Level 3 (BSL-3) and BSL-4 to adhere to new local standards, including:

- Obtaining a permit from the Boston Public Health Commission.
- Setting up an Institutional Biosafety Committee (IBC) that reports to a senior responsible official and that has at least two community members without a connection to the organization.
- Submitting reports to the BPHC on research, safety procedures, and IBC meetings.
- Following the highest safety standards outlined in the CDC/NIH manual on biosafety, *Biosafety in Microbiological and Biomedical Laboratories*.
- Reporting laboratory incidents or illness, and inspections.
- Prohibiting weaponization and classified research in Boston.
- Holding annual public meeting to review the type and nature of the biological research.
- Reporting intended decommissioning of a laboratory facility.
- Following rDNA or medical surveillance regulation requirements.
- Establishing a Community Benefits Program to support local health and safety needs as a mandate for BSL-4 laboratories.

## **Appendix Q**

### **Medical Surveillance Program**

BU and BMC provide free medical monitoring to all employees who face workplace risks. The program is designed to monitor potential health hazards associated with research and development activity with recombinant DNA, bloodborne pathogens, other etiologic agents, zoonotic diseases associated with laboratory animals, and hazardous chemicals. The details of the program are located at <http://www.bu.edu/buohc/research.html>

- Employment pre-screening
- Termination screening
- Serum banking (if any)
- PPD skin testing
- Policy on pregnant workers
- Policy on immunocompromised workers
- Vaccination



## **Appendix R**

### **Laboratory and Equipment Decontamination Procedures**

#### ***Decontamination of Lab Space and Equipment Punch List***

1. Designate a Move Coordinator.
2. Contact an outside vendor for the decontamination of biological safety cabinets (tissue culture hoods).
3. Have appropriate personal protective equipment available (lab coat, gloves, eye protection).
4. Dispose of old chemicals and all other chemical waste as hazardous waste. Notify the Hazardous Materials Manager at (617) 638-8830 upon termination of a hazardous waste site or with any questions on this issue.
5. Decontaminate all equipment that is either to be moved or left behind.
6. Contact the Safety Office regarding the discarding of equipment.
7. On the decon certificate, list all decontaminated equipment by room (one sheet per room).
8. Small pieces of equipment can be deconned and boxed by lab personnel.
9. Any working equipment to be left behind without a new owner must be reported to Facilities Management at (617) 868-4211.
10. Contact the Radiation Protection Office (RPO) for the decontamination and moving of radiological materials and work spaces.
11. Decontaminate all labs, including fume hoods, the outside of tissue culture hoods, cold/warm rooms, darkrooms, etc.
12. If perchloric acid was used in a fume hood, contact the industrial hygienist at (617) 638-8830.
13. Fill out one decon sheet for each room, tape one copy to the outside of the lab door (if it is a section of a lab, tape to bench), fax one copy to the Biosafety Office, and keep one copy for the records.
14. Disinfectants: the most common are 10-20% freshly diluted bleach (leave on for 20-30 minutes, then wash off), 70% EtOH, or isopropanol. Phenolic agents are not recommended.
15. If refrigerators, freezers, incubators, etc., are to be moved with content inside, make sure the content is well protected from sliding, breaking, etc.

16. The Move Coordinator must ensure the following emergency procedures are covered:
- Chemical spills
  - Biological spills
  - Fire
  - Personal injuries, such as slips, falls, cuts, etc.
17. Protective clothing and spill absorbent materials must be on hand.
18. The decontamination procedure document should be reviewed.

<b>LABORATORY OR EQUIPMENT DECONTAMINATION CERTIFICATION</b>
--

**DATE:** \_\_\_\_\_ **LOCATION (Bldg, Room #s)** \_\_\_\_\_

1. I certify that the rooms or equipment listed below, previously used by my laboratory, have been emptied of biological materials:

**Equipment:** \_\_\_\_\_

**(Mark with "\*" any equipment that contains fluid)**

2. The surfaces of these rooms/equipment have been decontaminated (if equipment: inside and outside) with: (specify decontaminants and percentages, i.e., 70% Ethanol, if 10% bleach is used, it must be freshly made up).

\_\_\_\_\_

3. All chemicals contained within the rooms or equipment have been drained and hazardous vapors have been released.

\_\_\_\_\_ Yes \_\_\_\_\_ No \_\_\_\_\_ N/A

4. All excess chemicals have been disposed of by the Hazardous Materials Manager (617-638-8830).

\_\_\_\_\_ Yes \_\_\_\_\_ No \_\_\_\_\_ N/A

5. All sink traps have been bleached and flushed with water (use 1 cup of concentrated bleach, wait 20 minutes, then flush thoroughly with water):

\_\_\_\_\_ Yes \_\_\_\_\_ No \_\_\_\_\_ N/A

6. Has RPO declared the equipment/area free of radioactivity:

\_\_\_ Yes \_\_\_ No \_\_\_ N/A If yes; **RPO Rep.:** \_\_\_\_\_ **Date:** \_\_\_\_\_

7. Does equipment contain fluid: \_\_\_\_\_ Yes \_\_\_\_\_ No

Name:		Phone Ext.:	
Signature:		Date:	
Dept., Bldg., Room #			
	Decontaminated By		Principal Investigator

***Laboratory Decommissioning and Relocation Procedures***

**Purpose and Applicability**

- It is the policy of Boston Medical Center and Boston University Medical Campus that laboratory decommissioning take place prior to the relocation of any laboratory space or upon vacating laboratory space or leaving either institution. In addition, safe-moving practices must be adhered to at all times.
- This policy is intended to minimize research and clinical lab downtime due to moving of a laboratory, and to protect contractors, laboratory personnel, and any other personnel involved in the process from laboratory hazards.
- This policy applies to all Boston Medical Center and Boston University Medical Campus employees and tenants occupying laboratory space within Boston Medical Center and Boston University Medical Campus buildings.

**Definitions**

- *Abandoned Laboratory:* A clinical or research laboratory that is left vacant by a Principal Investigator or Laboratory Supervisor and his or her laboratory staff, and has laboratory materials (biological, surplus chemical, radioactive), equipment or waste that has not been disposed of.
- *Biological Materials:* All human, plant, and animal pathogens; all human blood, blood components and products, tissues and body fluids; all human and animal cultured cells; all infected animals and animal tissues; all cultures/stocks of biological agents, including recombinant DNA materials; and all biological toxins. Also includes biomedical waste and physically dangerous (sharp) waste.
- *Decommissioning:* The process whereby a Principal Investigator or Laboratory Supervisor and his or her laboratory staff decontaminate existing laboratory space and make a clinical or research laboratory safe prior to vacating the space.

- *Decontamination*: The process whereby the Principal Investigator or Laboratory Supervisor and his or her laboratory staff clean and disinfect laboratory surfaces and equipment so they are safe to handle.

### **Roles and Responsibilities**

- The Principal Investigator or Laboratory Supervisor is responsible for the complete decommissioning of the laboratory space prior to vacating the laboratory. In cases where an abandoned lab is identified, the department that the PI or Laboratory Supervisor reported to will be responsible for the decommissioning and all costs associated with the process.
- The Environmental Health and Safety (EHS) Office will distribute this policy and attachments and advise Principal Investigators, Laboratory Supervisors, and laboratory personnel on how to implement the various aspects of the policy. They will also verify that a lab has been appropriately decommissioned before a Principal Investigator or Laboratory Supervisor may leave or move his or her laboratory.
- The Move Coordinator for the laboratory is appointed by the Principal Investigator or Laboratory Supervisor and is responsible for coordinating the laboratory decommissioning and move. The Move Coordinator is the primary contact with EHS.
- Other personnel (Facilities, moving personnel, and contractors) should be aware of this policy and should not handle laboratory materials, equipment, or waste unless instructed to do so by their supervisor and/or EHS.

### **Procedures: Preparation**

- Prior planning is key to a successful laboratory decommissioning and move. Preparation and communication with EHS will be a major factor in minimizing delays, protecting property against damage and loss, and most importantly, reducing the potential for personal injury. Contact EHS at (617) 638-8830 with any questions or for assistance.

### **Procedures: Waste Disposal**

- All biological waste and hazardous waste must be disposed of according to current EHS policies and procedures as outlined in the EHS *Policy Manual*. All radioactive waste must be disposed of according to Radiation Protection Office policies and procedures. Boxes and trash must not be left in corridors. Prior arrangements for regular trash must be made with Custodial or Environmental Services.
- Chemical waste must be labeled with hazardous waste stickers regardless of whether or not they are labeled from the manufacturer.

- Unwanted, unopened, or uncontaminated chemicals should be offered to other labs that may be able to use them before the chemicals are considered for disposal.
- Any unknown chemical must be identified and labeled as hazardous waste. For chemical unknowns that cannot be identified by the Principal Investigator, Laboratory Supervisor or laboratory personnel, the laboratory may be assessed a service fee for hazardous waste analysis prior to disposal.
- Darkroom tanks must be drained and the contents disposed of as hazardous waste. Empty compressed gas tanks must be returned to the distributor prior to the move. Mercury thermometers must be disposed of as hazardous waste, and vacuum pumps must be drained of oil and the oil disposed of as hazardous waste.

### **Procedures: Decontamination**

- All laboratory bench-top surfaces must be decontaminated prior to vacating the laboratory, and all laboratory equipment that is either remaining in the laboratory or being moved to a new laboratory must be decontaminated if potentially contaminated with biological, chemical, or radioactive materials.
- **Lab equipment** requiring decontamination includes, but is not limited to, animal cages, centrifuges, fermenters, fish tanks, incubators, water baths, refrigerators, and freezers (if not moving intact).
- **Fume hoods** must be decontaminated. Contact the Industrial Hygienist at (617) 638-8830 for decontamination and certification advice. Notify the Industrial Hygienist if there is any current or past practices that may reveal potential problems. Certain chemicals such as perchloric acid and mercury may remain on surfaces or equipment or in building systems.
- **Biological safety cabinets** and glove boxes that have been used with potentially infectious materials must be decontaminated using paraformaldehyde gas before moving. This must be done by a qualified outside contractor. If BSCs are either being moved to new laboratory areas or being left behind, contact the Biological Safety Officer at (617) 638-8830 to discuss decontamination well in advance of the move. BSCs that are moved must be re-certified after installation. Contact B&V Testing at (781) 891-9081 to arrange for re-certification.
- An appropriate disinfectant must be utilized in cases where biological materials were in use. A disinfectant is deemed appropriate if it targets the biological materials that were in use in the laboratory. In most cases, 70% ethanol, bleach solution (1:10 made fresh), or a phenolic disinfectant should be adequate for disinfection of lab furniture and equipment potentially contaminated with biological materials. Call the Biological Safety Officer at (617) 638-8830 with questions or concerns.
- A *BU Equipment Decontamination Record* sticker must be affixed to all equipment that has been decontaminated. This will allow moving personnel to safely move the equipment to the new

laboratory space. Only equipment with this sticker will be moved. Stickers may be obtained from EHS at (617) 638-8830.

- The Principal Investigator or Laboratory Supervisor must complete the “Laboratory Decontamination Certification Form” and submit the form to EHS (M-470) when decontamination and decommissioning activities are completed. This will allow EHS personnel to review the decommissioning activities, visit the decommissioned laboratory, and alert the appropriate administrative personnel that the decommissioning has been performed. Upon receipt of the completed form, EHS will contact the Principal Investigator or Laboratory Supervisor to schedule a tour of the laboratory to confirm the decommissioning activities.

- For more information regarding proper disinfection or decontamination procedures, contact EHS at (617) 638-8830 or the Radiation Protection Office at (617) 638-7509.

### **Procedures: Designation of New Laboratory Space**

- The Principal Investigator or Laboratory Supervisor must inform EHS of any new laboratory space, so that the appropriate safety signage may be provided.

- The Principal Investigator is responsible for notifying all applicable Boston University research committees and outside agencies, as necessary, of the move to new laboratory space. Research projects approved by the IBC must have updated laboratory location information. USDA Veterinary Service or Plant Service permits are laboratory site specific, as are CDC Select Agent registration permits. Contact the Biological Safety Officer at (617) 638-8830 for assistance.

### **Procedures: Packing and Moving Laboratory Materials**

- Laboratory personnel are responsible for collecting all packaging items needed before the move date. Carts, plastic bags, toweling, or other cushioning, absorbent materials, sealable plastic or plastic-lined boxes, labels (e.g. Fragile, Universal Biohazard, ID, Location, Caution, Radioactive Material), sturdy tape, and spill kits should be readily accessible. Each container or piece of equipment must be labeled. Labels must identify the agent, hazard, and necessary precautions.

- The Principal Investigator or Laboratory Supervisor is responsible for establishing safety and emergency procedures for all phases of the move. Potential emergencies include material spills, fires, slips and falls, and cuts. Protective clothing and spill absorbent materials must be available during packing, moving, and unpacking.

### **Procedures: Packing and Moving Laboratory Chemicals**

- In order to minimize the amount of chemicals that need to be packed and moved, new chemicals should be ordered only as necessary and in small quantities. Laboratory personnel should plan in advance to minimize the inventory of liquid volume and weight of materials being moved. In addition, reduction of active materials should be planned the week prior to the move. Laboratory

chemicals must be packed and moved by an outside contractor approved by OEHS. Prior to the packing and moving, laboratory personnel are responsible for labeling each chemical container with the chemical identity.

- **Compressed gas** tanks that are to be moved must have regulators removed and caps secured prior to moving. If possible, have old tanks collected prior to a move and arrange for future tanks to be delivered to the new location.
- **Thermometers** must be removed from refrigerators, water baths, and incubators prior to equipment moving.
- **Vacuum pump oil** must be drained from pumps prior to equipment moving.

#### **Procedures: Packing and Moving Biological Materials**

- **Biological materials** must be appropriately packed and moved by the laboratory personnel. Regulated materials and biological materials include all human, plant, and animal pathogens; all human blood, blood components and products, tissues and body fluids; all human and animal cultured cells; all infected animals and animal tissues; all cultures/stocks of biological agents including recombinant DNA materials; and all biological toxins.
- **Proper packaging** consists of a primary sealed container placed within a secondary sealed, unbreakable container, with enough absorbent material in between to contain and absorb any spill. *Some examples of proper packaging include* petri dishes in a plastic sleeve within a plastic-lined box using paper towel spacers; stabs in a sealed Tupperware container with paper towels to cushion vials; sealed tubes in a rack placed into plastic sealable container with enough paper towels to absorb any spilled contents; tissue culture dishes placed into a plastic-lined dishpan or a sealable cardboard box with an absorbent. Freezers can be moved intact, provided all contents are in sealed, unbreakable containers and the freezer remains closed. Because shifting of contents may occur, enclose loose items in boxes, or fix in some other way to avoid breakage and spills when the freezer is reopened. Other equipment, such as fermenters, refrigerators, incubators, and biological safety cabinets must be empty and decontaminated prior to the move.
- **Labeling:** Once packaged, all biological materials must be properly labeled. *Labels must include* the name, Principal Investigator (PI), new location, ID of agent, biosafety level, telephone number for assistance in the event of any breakage, and a FRAGILE notice if applicable. Also the **universal biohazard label** should be used whenever packaging a BSL-2 or higher agent. Questions concerning the biosafety level of biological materials or requests for biohazard labels should be directed to the Biosafety Safety Officer at (617) 638-8830.

#### **Procedures: Laboratory Furniture and Equipment**

- **Furniture:** The Move Coordinator must be informed if there is any furniture of particular concern (fragile, valuable, requires dismantling) not already mentioned. Different moving companies may have different requirements that should be ascertained in advance of the move.
- **Special Requirements:** The Move Coordinator must be informed in advance of any equipment under service contract, as well as equipment not under contract but requiring servicing and/or special handling.
- **Alarms:** Laboratory personnel must disconnect alarms on freezers (if moving intact) and any other sensor alarms on or before the day of the move.
- **Keys and Combinations:** Laboratory personnel must keep keys and combinations to locks readily accessible.



BUMC  
Biosafety Manual  
Revised Document  
October 12, 2007

**Appendix S**  
**Laboratory Door Signage**

Boston Medical Campus Door Sign Sample: This is completed in accordance with the NFPA 704 Hazard Identification ratings system (the NFPA "hazard diamond") for health, flammability, and instability

P.I./Manager's Name: Principle Investigator  
Location: \_\_\_\_\_  
Phone: XXX-XXX-XXXX  
Emergency Contact: Control Center 4-6666

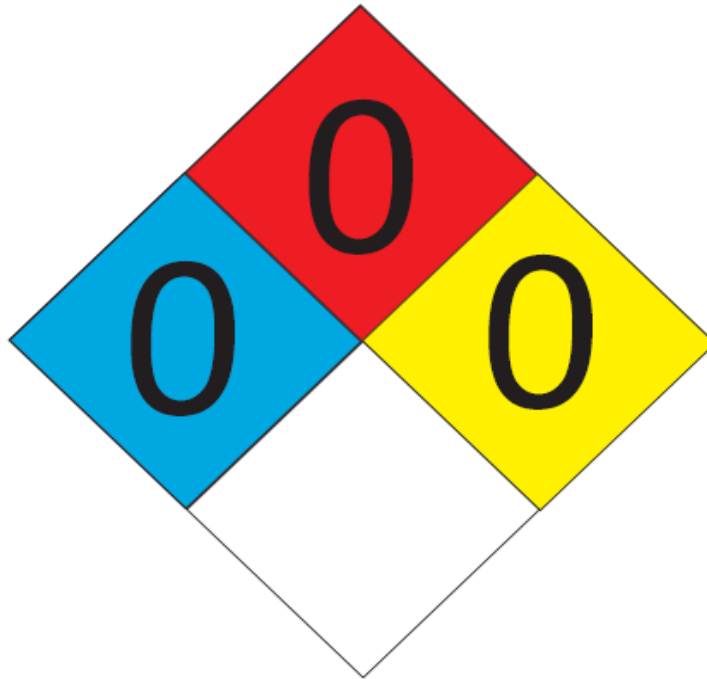

**BSL-X**



Radioactive Materials  
For emergencies call:  
RPO-638-7001  
Off Hours: 638-6666

**Appendix T**

## **Boston University and Boston Medical Center Research Compliance Policy on Disease Surveillance and Reporting for High-Risk Agents**

### **Purpose and Applicability**

This policy implements Boston Public Health Commission's (BPHC) *Guidelines for Implementation and Enforcement of Boston Public Health Commission's Disease Surveillance and Reporting Regulation* (see <http://www.bphc.org/>). The BPHC's guidelines require laboratory registration and a medical surveillance program for research laboratories working with high-risk agents. The guidelines are designed to ensure that BPHC receives timely access to information regarding incidence of disease syndromes, any outbreak or cluster of a disease, and potential exposures to reportable diseases deemed harmful to the public health.

This policy sets forth the roles and responsibilities of researchers and of compliance staff at BU and BMC, as mandated by the BPHC guidelines.

This policy supplements, but does not replace or supersede, any other existing BU or BMC policies or procedures. For example, additional procedures relating to laboratory safety are set forth by BUMC's Office of Environmental Health and Safety (OEHS) in the *OEHS Manual*, at <http://www.bu.edu/ehs/manual/index.html>, and other subsidiary OEHS documents. This policy also supplements, but does not replace or supersede, reporting requirements relating to industrial accidents for employees of either BMC at [http://www.bumc.bu.edu/www/bumc/ehs/pdfs/art\\_form.pdf](http://www.bumc.bu.edu/www/bumc/ehs/pdfs/art_form.pdf) or BU at <http://www.bu.edu/risk/pdf/accreport.pdf>.

### **Definitions**

The **Associate Vice President, Research Compliance** (AVP-RC) is the individual responsible for overall compliance oversight at BU and BMC.

The **Biosafety Office/Director** is the individual responsible for overall leadership of the biosafety program.

**Expose or Exposure** is any situation arising from, or related to, the work operation of BU or BMC where an employee or community resident may ingest, inhale, absorb through the skin or eyes, or otherwise come into contact with any high-risk agent.

**OEHS Executive Director** is the Executive Director of the Office of Environmental Health and Safety of Boston University and Boston Medical Center.

**Occupational Health Officer (OccHealth Officer)** is the physician(s) who is the Chief of the Office of Occupational Health at Boston University and at Boston Medical Center. The Occupational Health Officer may also name a designee to perform occupational health assessments or evaluations, provided that the designee is also a licensed physician experienced in occupational medicine or a registered nurse experienced in occupational health nursing.

**High-Risk Agent** is a select agent, defined as:

- agents in Risk Group (RG) 4 as specified in the National Institute of Health's *Guidelines for Research Involving Recombinant DNA Molecules and Biosafety in Microbiological and Biomedical Laboratories*, published by the Centers for Disease Control and Prevention and the National Institutes of Health and the

amendments and rulings made relative thereto from time to time. See

<http://www.cdc.gov/od/ohs/pdffiles/4th%20BMBL.pdf> and

[http://www4.od.nih.gov/oba/rac/guidelines\\_02/APPENDIX\\_B.htm](http://www4.od.nih.gov/oba/rac/guidelines_02/APPENDIX_B.htm).

- highly pathogenic avian influenza
- SARS Co–V
- any other agent identified by the director of BPHC on a list to be posted on the BPHC’s website at [www.bphc.org/labs](http://www.bphc.org/labs) or appearing on reporting forms. See <http://www.bphc.org/bphc/pdfs/LabReportCard.pdf>.

**Select Agent** means microbial and toxic agents listed at 42 CFR 73.4, 42 CFR 73.5, and 9 CFR 121.2 and the rulings made by the CDC and U.S. Department of Agriculture relative thereto as amended from time to time. See <http://www.cdc.gov/od/sap/docs/salist.pdf> and <http://www.nih.gov/od/ors/ds/pubs/appendxa.html>.

**Research Laboratory** is a workplace or a work area of a workplace that is used primarily for research, development, non–routine testing, or experimentation activity in which any high-risk agent is used by or under the direct supervision of a technically qualified individual.

**Work Area** is a defined space, or a room or rooms, or other area where infectious agents or substances are produced, stored, or used, and where employees are present in the course of their employment. A work area may include an entire workplace.

**Workplace** is an establishment or business of an employer at one geographic location at which work is performed and containing one or more work areas.

### Registration of Research Laboratories

- The office of the AVP-RC will be responsible for registering with BPHC all research laboratories possessing, producing, storing, or otherwise working with any high–risk agent.
- Such registration shall be on a form, or electronic format, provided by the BPHC’s Office of Environmental Health, and shall include the following:
  - Name of the high–risk agent.
  - The location of each high–risk agent (but only if such disclosure is consistent with federal, state, and institutional security restrictions and policies concerning select agents or high-risk agents).
  - Principal Investigator responsible for the high–risk agent(s).
  - Title and a brief description of the nature of the project.
  - Grant identification number or other unique institutional identifier number for the project.
  - Contact information for the IBC.
  - Name and contact information for the Occupational Health Officer.
- The information in the registration form shall be updated, on a form provided by the BPHC’s Office of Environmental Health, twice a year, every July 31 and January 31 (or on the next business day if it falls on a holiday or weekend) following registration.

The AVP-RC shall inform the Occupational Health Officer of all high-risk agents as they are identified at BU or BMC and shall provide the OccHealth Officer with a copy of each registration and update, simultaneously with filing.

## **Responsibilities of Principal Investigators, Supervisors, Laboratory Directors, and the IBC**

### **• Ensure Registration Prior to Project Commencement**

- The Principal Investigator, Supervisor, or Laboratory Director of any research project that proposes to possess, produce, store, or otherwise work with any high-risk agent must first contact the AVP-RC, or designee, and ensure that a registration for the research laboratory is properly filed with the BPHC.

### **• Develop Approved Plan Prior to Project Commencement**

- The Principal Investigator, Supervisor, or Laboratory Director of any research project who proposes to possess, produce, store, or otherwise work with any high-risk agent must:
  - develop a plan jointly with the OccHealth Officer that will enable the Principal Investigator, Supervisor, or Laboratory Director to determine whether a significant exposure of personnel has occurred in the Research Laboratory and that will set forth a protocol for monitoring significantly exposed employees (for more information, see “Medical Surveillance of Employees Working With High-Risk Agents” under “Responsibilities of the Occupational Health Officer”).
  - indicate in writing that the Principal Investigator, Supervisor or Laboratory Director, and OccHealth Officer have each approved the plan
- The plan must also be approved by the AVP-RC and the IBC before researchers on the project will be allowed access to a high-risk agent.

### **• Mandated Reporting to OccHealth Officer and OEHS Executive Director**

- The IBC, Principal Investigator, Supervisor, and/or Laboratory Director shall promptly report to the OccHealth Officer:
  - any diagnosis of any disease caused by a high-risk agent and
  - any laboratory employee or other individual having access to a research laboratory that possesses, produces, stores, or otherwise works with any high-risk agent **who is absent from the workplace due to illness for a period of two or more consecutive work days.**
- The IBC, Principal Investigator, Supervisor, and/or Laboratory Director shall report to the AVP-RC and the OccHealth Officer any violation or breach of any laboratory procedures or any other incident that the IBC, Principal Investigator, Supervisor, or Laboratory Director **should reasonably believe resulted in exposure of laboratory personnel to a high-risk agent in the workplace or released any high-risk agent beyond the work area.**

The manner of reporting to Occupational Health is outlined in the section, “Manner of Reporting to Occupational Health.”

### **• Follow-up on Reporting Requirements of Laboratory Workers**

Principal Investigators, Supervisors, and/or Laboratory Directors who learn of laboratory workers with reporting responsibilities as outlined in “Responsibilities of Laboratory Employees, Trainees, Students, and Others Who Have Access to High-Risk Agents” must confirm that such employees have reported to Occupational Health **before returning to work** and that the employees have a written release to return to work provided by Occupational Health.

Principal Investigators, Supervisors, and/or Laboratory Directors should refer any ill employee who has had access to a high-risk Agent to Occupational Health for evaluation.

### **Responsibilities of Laboratory Employees, Trainees, Students, and Others Who Have Access to High-Risk Agents**

#### **• Mandatory Reporting to OccHealth Officer, AVP-RC, and OEHS**

Laboratory workers or other individual having access to a research laboratory that possesses, produces, stores, or otherwise works with any high-risk agent and who are exposed to a high-risk agent from a spill or a breach in laboratory practices must immediately contact the OccHealth Officer, AVP-RC, and OEHS Executive Director to receive instructions as to appropriate immediate steps to be taken.

#### **• Mandatory Medical Evaluations**

- Any laboratory employee or other individual having access to a research laboratory that possesses, produces, stores, or otherwise works with any high-risk agent **and**
  - who has been diagnosed with, is exhibiting symptoms of, or may have been exposed to, any high-risk agent **or**
  - who has been absent from the work place due to illness for a period of two or more consecutive work days

must report to the OccHealth Officer prior to returning to work, for medical evaluation **before, and as a condition for**, returning to work.

- Laboratory workers are **encouraged** to report **any** illness to the OccHealth Director if working with high-risk agents, even if the illness does not result in a two-day workplace absence.

The manner of reporting to Occupational Health is outlined in the section, “Manner of Reporting to Occupational Health.”

### **Responsibilities of the Occupational Health Officer**

#### **• Medical Surveillance of Employees Working With High-Risk Agents**

- The OccHealth Officer is responsible for having in place a general plan to determine whether employees working with various high-risk agents have had a significant exposure to a high-risk agent and a plan to monitor significantly exposed employees.

- The OccHealth Officer will work with the Principal Investigator, Supervisor, or Laboratory Director on any research project that proposes to possess, produce, store, or otherwise work with any high-risk agent to:
  - develop the project-specific plan described in “Develop Approved Plan Prior to Project Commencement” as outlined in “Responsibilities of Principal Investigators, Supervisors, Laboratory Directors, and the IBC,” which will enable the Principal Investigator, Supervisor, or Laboratory Director to determine whether a significant exposure of personnel has occurred in the research laboratory and which will set forth a protocol for monitoring significantly exposed employees; and
  - ensure that the project-specific plan is approved by OEHS and the IBC before researchers have access to a high-risk agent.

#### • Reporting to BPHC

The OccHealth Officer is responsible for generating the following reports and reporting to the BPHC as indicated:

##### • Report of Diagnosis, Symptoms, or Exposure

The OccHealth Officer shall perform an occupational health assessment for any laboratory employee or other individual having access to the laboratory who

- has been diagnosed with
- is exhibiting symptoms of *or*
- may have been exposed to

any high-risk agent.

The findings of the assessment shall be immediately reported to the BPHC, but in any event not later than one business day after completion of the assessment. The Reporting Form can be found at <http://www.bphc.org/bphc/pdfs/LabReportCard.pdf>.

The OccHealth Officer will conduct a follow-up assessment and provide information requested by BPHC regarding isolation and/or quarantine issues. If the determination is made that the illness is caused by a high-risk agent, BPHC will be consulted before an ill worker is allowed to return to work.

The OccHealth Officer will send BPHC documentation that an exposed person has been cleared to return to work within three business days of clearance.

##### • Report of Workplace Absence Due to Illness

The OccHealth Officer shall perform an evaluation of any laboratory employee or other individual having access to a research laboratory that possesses, produces, stores, or otherwise works with any high-risk agent **and** who has been absent from the work place due to illness for a period of two or more consecutive work days.

The evaluation shall be completed prior to the employee’s return to work.

If the OccHealth Officer has a reasonable suspicion that the employee’s illness may be related to an

exposure to any high-risk agent, the OccHealth Officer shall immediately notify the BPHC, but in any event not later than one business day after completion of the assessment.

If OccHealth determines that the illness was caused by a high-risk agent and may be work related, the BPHC must be consulted at least three business days prior to the employee's expected return to work.

**• Report of Diagnosis of Disease**

The OccHealth Officer shall report to the BPHC any diagnosis of any disease caused by a high-risk agent.

This report shall be made within one business day of the diagnosis.

**• Report of Violation of Laboratory Procedures Resulting in Release of High-Risk Agent**

The OccHealth Officer shall report to the BPHC any violation or breach of any laboratory procedures or any other incident which the OccHealth Officer should reasonably believe released a high-risk agent beyond the work area.

This incident shall be reported to BPHC within one business day of the breach or incident.

**• OEHS Notification**

The OccHealth Officer shall provide the AVP-RC and OEHS Executive Director with written notification of all reports made to the BPHC.

## **Manner of Reporting to Occupational Health**

All reports to Occupational Health shall be made in accordance with the following:

**• For service between 7:30 a.m. and 4:00 p.m. weekdays:** Contact Boston Medical Center Occupational and Environmental Medicine at 732 Harrison Avenue, Preston Family Building, 5th floor, Boston, MA 02118, (617) 638-8400 and ask to speak with the Chief of Occupational Medicine and OccHealth Officer or the Medical Director in the absence of the OccHealth Officer.

**• For service before 7:30 a.m. or after 4:00 p.m. or on weekends and hospital holidays:** Report to BMC Emergency Department, located at 771 Albany Street for assessment and treatment. The department may be reached at (617) 414-4075.

## **Responsibilities of BMC Emergency Department Personnel**

BMC Emergency Department (ED) personnel act as designees of Occupational Health for reports that are made on hospital holidays, weekends, and before 7:30 a.m. and after 4:00 p.m. on weekdays and must take the following steps when an individual reports to the BMC ED:

**• BMC ED personnel (or other providers at BMC or outside the Boston area) who evaluate workers for potential or actual exposure in connection with illness, absence, or breach in laboratory practices that is**



potentially related to work with a covered agent **must contact the Chief of the Office of Occupational Health at the 24-hour contact telephone, (617) 638-4144.**

- BMC ED personnel should also contact OEHS and the chair of the IBC by using the 24-hour contact telephone, (617) 638-4144. Information to be provided should include the name of the caller, the person(s) involved, the type of situation, and a call-back number.
- BMC ED personnel should contact the Hospital Epidemiologist at (617) 414-5037 or pager (617) 638-5795, ID # 6402, or page the BMC Infectious Disease Consultant on call at (617) 638-5795, pager ID # 8902 for the Harrison Avenue Campus, or pager ID # 8903 for the East Newton Campus.

Reporting forms for hospital laboratories can be found at <http://www.bphc.org/bphc/reportforms.asp>.

## Appendix U

### Institutional Biosafety Committee Oversight Program

Various regulatory agencies with oversight of research activities involving the use of etiologic agents or recombinant DNA, funding agencies, and BU and BMC policies require that a comprehensive, ongoing inspection and audit program be in place to review the compliance record of the users and the facility.

This includes:

- the review of procedures to ensure compliance with the terms of approved protocols (e.g., biological materials, animals)
- Inventory controls
- General facility conditions
- Training of individuals engaged in research
- Other specific mandates required by the particular agency or IBC

#### • Oversight

The IBC has responsibility for the oversight program that will fall under one of the three broad categories defined below:

##### *Inspections*

Inspections are conducted as a result of a specific issue or concern and could be prompted by receipt of a complaint, request from a regulatory agency, or the Institutional Oversight Committee. All these instances will be investigated in accordance with the protocols established by IBC and the results will be reported to the IBC.

The IBC's chair or the vice chair and the Associate Vice President, Research Compliance (AVP-RC) will be notified immediately at the initiation of any inspection. Upon notification, the IBC chair or vice chair will review the nature of the event leading to the investigation and determine if any immediate action is required. Such actions might include, but are not limited to:

- Establishment of a sub-committee to participate in the inspection or to discuss the violation before the next convened full committee meeting.
- Temporary suspension of activities or closure of the facility.
- Other actions as necessary.

##### *Audits*

Audits are part of the routine quality control program during which staff conduct ongoing audits of approved protocols.

The frequency, extent, and content of the audits will vary depending on the specific protocol being audited and will be developed by the IBC and the Biosafety Officer (BSO).

At the end of each audit, the staff will:

- Discuss their findings with the PI or the alternate responsible person named in the protocol when appropriate. The discussion will include any corrective actions needed.
- Send, within five working days, the PI or the alternate responsible person a written report describing any findings, corrective actions required, and the deadline for a written response.
- Determine, upon receipt of the responses from the PI, if a follow-up visit is necessary to conclude the audit. In the event of failure by the PI to respond to the report in a timely manner, staff will contact the PI by phone or in person.
- Determine the type and severity of the findings and corrective actions taken.
- Report the findings to the committee.

#### *Lab Review*

Reviews are site visits conducted to observe certain procedures or activities and may be requested by the IBC or the PI. In general, the purpose of these reviews is to observe an activity (e.g., a PI is starting a procedure that he or she has not conducted before) and provide feedback to the IBC or a PI. Depending on the nature of the request, these reviews are often excellent forums for training and may or may not require a formal report to the IBC.

#### • **IBC Review and Enforcement**

At the conclusion of an inspection or audit, the BSO, or designee, will report the findings to the IBC, or the sub-committee if one was appointed, for review and action. The report will include any corrective actions taken or in progress.

The IBC will review the findings and determine the appropriate corrective actions depending on a number of factors, such as the severity of the infractions, nature of the violation, or the history of PI and/or laboratory compliance.

In general, the IBC views the violations as:

- *Major deviations:* These are the type that have the potential for causing health or safety problems and may include deviations such as failure of monitoring; departure from approved protocol; use of unapproved biological agents; unauthorized removal of agents; etc.
- *Moderate Deviations:* These are the type that are either major administrative or have a likelihood of causing minor health and safety problems and may include personnel qualified but not added to protocol, missing inventory records, QC not performed in a timely manner, etc.
- *Minor Deviations:* These are generally of the type that are administrative in nature and have insignificant potential for causing health or safety problems and may include incomplete records (e.g., missing dates or initials), posting infractions, etc.

## **Enforcement**

In any category, the PI will be given a deadline to respond to the IBC report with an explanation of the reason for failure and plans for correction and/or protocol modification as necessary.

**Note:** *The PI has an opportunity to present his or her case to the full IBC should he or she so desire.*

After review of the inspection report and the PI's response, and after reviewing the facts surrounding the violation, the IBC will take appropriate corrective action may impose sanctions.

This action may range from, but is not limited to:

- Requiring more frequent laboratory inspections and/or monitoring.
- Mandated additional training.
- Requiring the PI and/or authorized users to re-take the user certification test.
- Placing the PI on probation for a period of time.
- Removing certification of certain individuals.
- Suspension of the approval of the protocol.\*

\* Only the IBC can authorize reinstatement. In making a finding regarding reinstatement, the IBC will consider the PI's corrective actions (taken or planned) and the results of an additional inspection.

**Note:** *The IBC and BSO have been given full authority to suspend any activity that is judged to be:*

- *Unapproved*
- *A clear violation of the approved protocol or regulatory requirements*
- *Have adverse health or environmental impacts*

## **Notification**

At the initiation of any inspections, the following notifications must be done immediately:

- AVP-RC, who will initiate any agency notification necessary.
- IBC chair or vice chair, who will determine immediate actions required.
- Occupational Health Officer, if there is a potential for employee exposure. The Occupational Health Officer will initiate relevant health agency notifications.

## Appendix V

### Criteria for Development of Standard Operating Procedures (SOP)

In this manual, there are a number of sections where the laboratory is required to prepare standard operating procedures (SOP). This appendix is intended to provide guidelines on the development of such documents. It is not mandatory to follow these procedures.

#### • Introduction

##### • *What is a Standard Operating Procedure (SOP)?*

A standard operating procedure (SOP) document is a comprehensive set of instructions written to provide employees with guidelines to follow to complete a job safely. SOP should be written in a manner that provides the user with a clear set of guidelines that ensure the task is performed as desired by the institution and that meet regulatory compliance standards.

Institutions write SOPs for the following reasons:

- to provide individuals who perform operations with all the safety, health, environmental, and operational information required to perform a job properly;
- to ensure that operations are done consistently to maintain quality control of processes and products;
- to ensure that processes continue and are completed on a prescribed schedule;
- to ensure that no failures occur in manufacturing and other processes that would harm employees or anyone in the surrounding community;
- to ensure that approved procedures are followed in compliance with company and government regulations;
- to serve as a training document for teaching users about a process;
- to serve as a historical record of the how, why, and when of steps in a process for use when modifications are made to that process and when a SOP must be revised;
- to serve as an explanation of steps in a process that can be reviewed in incident investigations that seek to improve safety practices and operating conditions.

#### • Purpose and Scope of this Document

The purpose of this document is to provide guidance and a template for drafting SOPs.

#### • Developing a SOP

Except for the simplest operations, a SOP must be developed for each of the operations for reasons described above. A SOP is best developed by a team that includes the worker, the job supervisor, a safety and health professional, etc. When an SOP has been properly written, the result is satisfactory completion of the work with regard to efficiency, risk, and safety.

The first step in preparing to write a SOP should have the worker demonstrate how he or she will accomplish a particular procedure. The worker must be someone who is already doing that job or who has done similar work. The supervisor acts as an advisor to monitor the required efficiency and contributes necessary information about the correct use of the equipment involved. The safety person notes the hazards of the job and lists the protective equipment that should be required.

The SOP should include identifying information (e.g., title and/or number) and all the procedure's steps, including associated hazards and precautions. Precautions for the employee's overall health and safety must be addressed, especially in terms of training and personal protective equipment and what to do in emergencies. The SOP also must address the precautions needed to prevent any impacts to the environment, whether it is the immediate workplace environment, the waste disposal system, or the surrounding community.

**Note:** *Detailed information does not need to be provided on some of the areas where there is already another document describing the procedure. For example, when describing the operation of a particular piece of equipment, a notation could be included that refers to the operating manual for that equipment or another SOP describing the operation. In these instances, it is important to ensure that these referenced documents are readily available.*

#### • **SOP Template**

No standard SOP templates exist nationally, so each institution develops its own. The template presented at the end of this SOP is compliant with the requirements of Good Laboratory Practices (GLP) and will be used for all SOP developed by the Office of AVP-RC and is strongly recommended for use by others.

#### • **General Information**

This is the top section of the SOP template and includes information about:

- *Unit:* The unit that develops and owns the SOP.
- *SOP Title:* The full title of the SOP.
- *SOP number:* Based on a standard numbering system.
- *Version:* The version of the SOP with V1.0 as the initial number and each subsequent revision having a new number such as V1.1.
- *Implementation Date:* The date the current version of the SOP went, or will go, into effect.
- *Approval:* The name and title of the individual who is responsible for approving the SOP. The responsible individual must sign or initial this section to indicate approval.
- *Page Number:* Indicates the page number using the notation "Page 1 of X."
- *Expiration date:* If the SOP is for a given operation that is for a specific duration, it should indicate that date; otherwise it should note "*until revoked.*"

#### • **Purpose and Scope**

There should be brief statement on the purpose and scope of the SOP.

- ***References***

This section should list any additional resources that may be useful in performing the procedures. These may include:

- **Regulations**

Regulatory references should be listed here.

- **Policies**

All relevant BU policies should be listed here.

- **Other SOP**

SOP referred to in any other section of this SOP should be listed here.

- **Supplementary Documents**

- ***Definitions***

Definitions for the major terms used in the SOP should be included to provide the reader a clear understanding. Spell out the acronyms fully and show the abbreviations in (); this format should also be followed each time a new term is introduced in any part of the SOP.

- ***Roles and Responsibilities***

If the particular procedures require that individuals from various sections participate, the roles and responsibilities for each should be clearly defined. For example, if a procedure requires a cage washer to deliver clean cages to the rooms before the technicians responsible for changing the cages can do so, define the roles. If OEHS must perform hazard evaluation as part of the SOP, OEHS's role and responsibility should be defined.

- ***Special Requirements***

- **Equipment and Supplies Required**

This section should list all equipment and supplies needed for performing the task or procedures. In a SOP with extensive supply list, it might be more appropriate to include the supplies in the description of each procedure.

- **Safety Requirements**

This section should define all health, safety, and environmental protection measures that must be followed while performing the procedures, including spill and accident response procedures relevant to the particular operation defined in the SOP.

- **Training**

Clearly define all the training requirements (i.e., courses), including the schedule for training (e.g., prior to the start of performing the procedures), re-training frequency, and how to obtain the courses.

- **Monitoring Requirements**

This section should define the need, frequency, and methods of conducting personnel or environmental monitoring.

- **Personnel Protective Equipment (PPE)**

List all the PPE required for performing this task, identifying which are mandatory and which are recommendations for further enhancing employees' health and safety.

- **Medical Surveillance**

Clearly define the medical surveillance requirements for the procedures, if any.

- **Other Prerequisites**

List any other prerequisites that exist for performing the procedures. These could include requirements for being familiar with companion policies, professional or special operating permits, etc.

- ***Applicable Locations***

List all locations where this SOP is applicable to (e.g. all barrier facilities, all research laboratories, areas where nano-particles are used, Rooms 111, 222 and 333 only, etc.)

- ***Procedures or Instructions***

This is the most important component of the SOP and requires a complete and step-by-step description of how the function should be performed.

When developing this section, consider the possibility of using the document as a training tool for new employees. Therefore, the details included should be such that after reading the document, a new employee could obtain a high level of understanding of how the function is performed.



Include the equipment used as part of this section and reference any SOP or operating manuals required.

**Note:** *Some SOP might include a listing of all equipment used at the start of this section.*

The title of any manufacturer's manuals, good practices, and professional organization guides, available or used in this procedure, should be listed here. The location of these documents should also be noted.

**Note:** *To avoid the need for frequent updating of the procedures, each program should designate a permanent location that acts as a reference library.*

• ***Forms***

The SOP should include all the forms required by the SOP. It is recommended that:

- All forms are included as attachments to the main SOP with a clear reference in the "Procedures and Instruction" or "Record Management" sections. This will make revisions of the SOP simpler if forms are changed.
- A form numbering system is established that correlates to the SOP numbers.

• ***Record Management***

This section incorporates record management practices, including location of active records, archived records, and record retention times.

• ***SOP Revision History***

It is extremely important to track the history of the SOP and document all its revisions. This expectation should be integral part of all SOP development and maintenance processes.

The SOP should be reviewed by the team that created it:

- When there is a change in regulatory requirements
- Operating procedures have changed significantly
- Forms used or the record management system has changed
- Introduction of new facilities, equipment, risks, hazards, or processes
- At least annually

The following pages provide a template for use.

<b>Unit:</b>	<b>SOP #:</b>
	<b>Revision #:</b>
	<b>Current Version Implementation Date:</b>
<b>Page #:</b> Page 186 of 187	<b>Last Reviewed/Update Date:</b>
<b>Expiration Date:</b>	<b>Approval Authority:</b>
<b>SOP Titles</b>	

1. Purpose and Scope
2. References
  - 2.1. Regulations
  - 2.2. BU Policies
  - 2.3. Other SOP
  - 2.4. Supplementary Documents
3. Definitions
4. Roles & Responsibilities
5. Special Requirements
  - 5.1. Equipment and Supplies Required
  - 5.2. Safety Requirements
  - 5.3. Training
  - 5.4. Monitoring Requirements
  - 5.5. Personnel Protective Equipment (PPE)
  - 5.6. Medical Surveillance
  - 5.7. Other Prerequisites
6. Applicable Locations

**7. Procedures and Instructions**

**8. Forms**

**9. Records Management**

**10. SOP Revision History**

Version	Section / Paragraph Changed	Changes Made	Effective Date
V.1	N/A	None, Original Version	