

POPES AND PORNOCRATS: ROME IN THE EARLY MIDDLE AGES

by *Lindsay Brook*¹

ABSTRACT

Rome between the late ninth and the mid-eleventh centuries was in turmoil. Rival families fought for control of the city, successfully fighting off the Saracens encamped close to the city, and then against various interlopers, from Lombardy, Tuscany and Germany. This article tries to use prosopography and genealogy to document the stratagems employed by the Roman aristocracy in this period to gain and retain power, especially through placements of popes. An Appendix shows how brutal and short the lives of many of these medieval popes were.

Foundations (2003) 1 (1): 5-21

© Copyright FMG

'For half a century Theodora ... and her equally infamous daughters ... filled the see of Peter with their paramours, their sons and grandsons ... the so-called Pornocracy'

Kurtz, 1860, II, §126, 379²

Popes have always been politicians, from choice, necessity or a mixture of both. In the middle ages, often it was a matter of personal survival. The period examined in this article – the late ninth to the mid eleventh century – is especially fascinating. It saw the fragmentation and collapse of the Carolingian empire, the rise and fall of successor dynasts and the attempt by the German emperors to assert their control over Italy. The chaos beyond Rome allowed three powerful Roman families during this time to exercise an unprecedented influence upon the choice of popes, and as far as possible to keep the appointment in the family. The papacy was regarded as no more than a pawn – albeit an important one – in incessant power struggles between various factions in Rome and its environs, and between them and dynasts elsewhere who sought to control the city and the Holy See³.

Poole (1917b, p. 472) makes an important observation:

'what is remarkable is that with the exceptions of Anastasius IV and Adrian IV there is ... no return to the names of the popes who reigned between Nicholas I (d.867) and Clement II (1046): There is no John, Marinus, Theodore, Benedict, Sergius or Boniface; Leo and Stephen appear but once. It is not until 1276 that any of these names are again used ...'

I suggest that later popes adopted this naming pattern in a deliberate effort to distance themselves from the murky and discreditable record of their predecessors during the 'pornocracy'.

On the other hand, it would be quite misleading to portray all, or even most, of the popes of the era as worldly and corrupt. Surviving documents (and there are obvious *lacunae*) make it clear that many were competent administrators, and skilful diplomats in difficult and dangerous times. Some were even reformers, keen to root out discreditable

¹ The author is the chairman and co-director of the Foundation for Medieval Genealogy.
Contact details: c/o FMG (see inside cover of this newsletter)

² Pornocracy: 'Dominating influence of harlots or prostitutes, spec. the government of Rome during the first half of the tenth century' (Oxford English Dictionary).

³ '... the local nobility ... sought to strengthen themselves by exciting the lesser people to riot and pillage' (Poole, 1917c).

practices such as simony. Others ordered the rebuilding and restoration of Rome's churches and palaces. John X led troops into battle against the Saracen predators in 915. Rather, it is the manner of the election of many of them and their symbiotic relationship with the Roman aristocracy that has earned their regime the designation 'pornocracy'⁴.

The genealogies of the great Roman families of early medieval Rome are notoriously difficult to unravel. In this article I have concentrated upon three families – the Theophylacts/Crescenzi, the Alberics and the counts of Tusculum (*Tuscolani*) – whose members who sought to exert their control over Rome and the patronage that the papacy was able to exert, and those who were popes themselves. The prosopography is, therefore, deliberately not complete⁵. Toubert (1973a) provides a useful summary of, and commentary on, some of the sources for the history in the 10th and early 11th centuries (p.961, note 1). He adds, as an annex to Chapter IX, illustrative genealogical tables (pp.1085-1087). My work is based on his, but with additions from many other secondary sources. I disagree with Toubert on some points and also make a few suggestions of my own⁶. Williams (1998) provides a genealogy of the 'House of Tusculum (Alberichi, Crescenzi, Colonna)' on p.12. It is not based on modern sources, however, and should be treated with considerable caution.

Through Theodora, wife of Pandulfus of Salerno, *dominus* of Capaccio, these Roman families are in all likelihood⁷ ancestors of many people alive today, almost none of whom realise that several of their uncles were popes (see especially Taviani-Carozzi, 1991, p.371). This may be of interest to some readers of this Newsletter.

Table I. A prosopography of selected members of the great Roman families of early medieval Rome

The relationships are shown in Fig 1 and Fig 2 on pp.16-17 below.

1	Theophylactus (I)	<i>Judex 901⁸, vestararius,⁹ gloriosissimus dux 906, consul et senator Romanorum 915¹⁰, magister militum, liv. 901. d. c 920, certainly before March 927</i>
---	-------------------	---

Sources: Poole (1917c, p.230); Llewellyn (1971, p.297); Teofilatto (1982, pp.223-224)¹¹.

⁴ We must be especially circumspect about the writings of Liutprand of Cremona, perhaps the most polemical of the tenth century chroniclers, who had his own agenda to promote the revived western Roman Empire. See Llewellyn (1971, pp.299-300).

⁵ I intend to place a more complete genealogy on the Foundation's website at a later date.

⁶ Toubert (1973a, pp.972-973) makes the interesting suggestion that the alliance between the Roman nobility and the Papacy was finally cemented with the victory over the Saracens on the bank of the river Garigliano in 916. Mutual interests were successfully served, and there followed a period of relative stability after the Formosan feuds.

⁷ This *caveat* is needed because the account of the descendants of the lords of Capaccio given by Drell (2002) differs from that of others in an important respect. This matter will be discussed, and perhaps resolved, in a future article.

⁸ The date of Theophylact's first documented appearance seems to have been February 902, not 901 as usually said (Fedele, 1910, p. 204, note 2).

⁹ Keeper of the papal treasury, one of the highest administrative posts which a layman could hold in the papal court.

¹⁰ According to Gregorovius (vol. 3, p.253), the city's nobility elected one of their number as *Consul Romanorum*, in effect as prince, an appointment that had to be confirmed by the pope.

Notes: It is certain that he belonged to the Roman nobility (Fedele, 1910, p.207ff). Toubert has suggested a plausible descent, though a generation may be missing¹². Theophylactus (I) and Theodora (I) almost certainly had other children, among whom were Sergia and Bonifacius (Teofilatto, p.229; Gregorovius, vol. 3, p.251, note 1).

1a Theodora (I) *Senatrix, patricia, vestararissa*, d. after 916, certainly before 927

Sources: Poole (1917c, p. 230); Llewellyn (1971, pp.297-300); Williams (1998, p.13).

Notes: Her father may have been called Glicerius, although this is disputed (Fedele, 1910, p.207). '... a vigorous woman but, unlike the other remarkable women of this family, charitable, pious and faithful to her husband ...', (Llewellyn, p.297). Liutprand of Cremona, writing long after her death, on the other hand called her a '*scortum impudens*' (shameless whore), who was the mistress of Pope John X (914-928). Available evidence suggests that this is malicious nonsense¹³. However, John undoubtedly owed his elevation to Theodora's patronage.

2 Marozia (I) Born *c* 890, *senatrix, patricia*, d. before 28 June 936

Sources: Llewellyn (1971, pp.303-305); Williams (1998, pp.13-14).

Notes: When a powerful husband died on her, she quickly found another one¹⁴. Regained power in Rome in a *coup d'état* in 927, but ejected from power by her son Alberic (II) in 932¹⁵, following her second marriage¹⁶, and imprisoned.

2a **Sergius III**¹⁷ **Pope, 897; 904-911**

Sources: Kelly (1986, pp.119-120)

Notes: His father was called Benedictus¹⁸. Williams claims that he was 'related to the counts of Tusculum' (p. 11), but does not cite his source; 'Che egli appartenesse ad una delle nobili famiglie di Roma è assai probabile' Fedele (1910, p.188).

¹¹ Teofilatto (1982) provides a useful list of people (mainly Roman) called Theophylactus, the spur to publication clearly being his own surname. Unfortunately the article is of uneven quality and based on the patently wrong assumption that all or most people named Theophylactus belonged to the same family.

¹² Theophylactus (I) may have been descended from a certain Theophylactus, *nomenclator*, mentioned in 829, father of Gregorius, *nomenclator*, *c*870. See also Teofilatto (1982, pp.222-223) and Toubert (p.1215, note 1). However, we lack reliable sources to establish this link.

¹³ See also Fedele (1910, p.213), who points out that no contemporary writers spoke of Rome as having '*un governo femminile*' in the first two decades of the tenth century. Things changed when Marozia (I) took centre stage. '*Sujugatus est Romam potestative in manu femine, sicut in propheta legimus: Feminini dominabunt Hierusalem!*', Benedetto di S. Andrea, *Chronicon*, p.714, quoted by Fedele (pp.215-216).

¹⁴ Her second and third husbands were half-brothers, a fact seized upon by her detractors.

¹⁵ See Arnaldi (1960a, pp.647-648) for a detailed account of the insurrection.

¹⁶ Llewellyn (1971) provides a useful list of contemporary polemical writings (p.299, note 12).

¹⁷ For a discussion of his alleged relationship with Marozia (I), see Fedele (1910, pp.220ff). Fedele has grave doubts as to the veracity of Liutprand's account. 'A man ... the value of whose statements is diminished by the frivolity of his character.' (Gregorovius, vol. 3, p.249).

¹⁸ '*Sergius natione Romanus ex patre Benedicto*', Liber Pontificalis, II, 236 (cited by Fedele, 1910, p.188).

2b Albericus (I) Marquis of Camerino and Spoleto, liv. 889, m. Marozia (I) c 915, perhaps *consul* 917, d. c 925

Sources: Arnaldi (1960b)

Notes: ‘...*forse di origine transalpina...*’ (Arnaldi, p.657); ‘... a Frankish adventurer ...’, Llewellyn (1971, p.296). A *protégé* of Pope Sergius III, he seized Spoleto by force and married into the Theophylacts. He may have been lynched by the Roman mob, after he sought the help of the marauding Hungarians to maintain him in power (Llewellyn, p.303; Gregorovius, vol. 3, p.274).

2c Guido/Wido of Tuscany Born 896, marquis of Tuscany 915, d. 928/929

Sources: Werner (1967, folding table).

Notes: Guido was the son of Adalbert, marquis of Tuscany, d. 915 by Bertha, d. 925, daughter of Lothar II, king of Lotharingia/Lorraine.

2d Hugo of Provence Born c 880, count of Vienne 903, king of Italy 926, d. 947

Sources: Werner (1967, folding table).

Notes: Son of Theotbald, count of Arles 879/891, d. 887, by Bertha, d. 925, daughter of Lothar II, king of Lotharingia/Lorraine.

3 Theodora (II) d. before 945. *Senatrix omnium Romanorum*

Sources: Poole (1917c, pp.229-233)

Notes: ‘... Theodora ... with her sister the elder Marozia ... occupied a position of unequalled influence at Rome in the early part of the tenth century’ (Poole, p.233)

3a Johannes ‘de Episcopo’ (Crescentius) *Dux, vestararius*, d. not later than 965

Sources: Cecchelli (1935); Romeo (1984b); Kelly (1986, p.129); Müller (1930, p.17 & note 159).

Notes: His origin is not known. His brother may have been Demetrius de Melioso, liv. 946-979, uncle of Marozia (II)¹⁹

73b David Probably living in the mid tenth century

Sources: Kelly (1986, p.131).

Notes: ‘...kinsman of prince Alberic II ...’ Kelly, p.131. We appear to know nothing else about him.

4 Albericus (II) Born probably c 905-910. Possibly marquis of Spoleto, 928²⁰. *vestararius, senator et princeps Romanorum*, 932 - d.954

Sources: Principally Arnaldi (1960a).

¹⁹ ‘In 979, after the death of Marozia *nobilissime femine*, her uncle Demetrius at her desire gave property at Zizinni to the monastery [of Subiaco]’, (Poole, 1917c, p.231). Gregorovius (vol. 3, pp. 345, note 1) stated that he was the son of Meliosus, *consul et dux*.

²⁰ Alberic (II) does not however appear in the detailed list provided by Gasparrini Leporace (1938) of the dukes of Spoleto.

Notes: He was an exceptionally able, though ruthless, ruler who preserved Rome from the meddling of outside powers for nearly a quarter of a century. In particular, see Toubert (1973a, pp.974-998). But meantime, Rome became less like the head of Christendom, more like another Italian city-state²¹. Shortly before he died, he made the Roman nobles swear to elect his son Octavian to the papal throne upon the death of the incumbent Agapitus II.

4a Alda of Provence (Vienne) Born *c* 925, m. 936, d. 954

Sources: Werner (1967)

Notes: Daughter of Hugo, King of Italy, d.947, by his second wife (?Alda) '*ex Francorum genere Teutonicorum*'. The marriage brought to an end Hugo's attempts to wrest Rome from Alberic's control until 941.

?5 **John XI** Born *c* 906, **Pope, 931-935**

Sources: Kelly (1986, p.123); Poole (1917c, p.230); Llewellyn (1971, p.304)²².

Notes: Kelly follows the *Liber Pontificalis* and the chronicler Liutprand of Cremona in making John XI 'almost certainly' the illegitimate son of pope Sergius III and Marozia (I)²³. Poole (1917c, p.230) and Llewellyn (p.304) make him Marozia's legitimate son by Alberic (I). The matter will probably never be resolved.

6 **Benedict VII** **Pope, 974-983**

Sources: Kelly (1986, pp.131-132); Gerstenberg (1937-39).

Notes: 'A Roman aristocrat, son of David, kinsman of Prince Alberic II ...', previously bishop of Sutri (Kelly, p.131). His mother may have been Theodora (II) (Gerstenberg), so it is perhaps not too fanciful to suggest that David was her second husband²⁴.

7 **(Octavianus), John XII**²⁵ Born *c* 937. **Princeps Romanorum, 954-964, Pope, 955-964**

Sources: Kelly (1986, pp.126-127).

Notes: Perhaps the son, not of his wife Alda, but of a concubine (Arnaldi, 1960a, p.655). I can find no reliable evidence for this assertion by Benedict of Soracte. '... the first undoubted instance in which a pope was known by two names', Poole (1917b, p.467). If Liutprand and other chroniclers can be believed, upon his accession John 'plunged into the most unbridled sensuality. The Lateran palace was turned into an abode of riot and debauchery' (Gregorovius, vol. 3, p.330). Even allowing for some exaggeration, it is clear that he was a weak and self-indulgent ruler.

²¹ I have heavily borrowed from Llewellyn's perceptive remarks (pp. 305-306).

²² The chronicler Flodoard of Rheims characterised John XI as 'empty of power, caring only for splendour, having only ceremonial duties' (Llewellyn, 1971, p.304).

²³ Liutprand of Cremona is disparaged by Mann (1925): '[Sergius III's] illicit intercourse with Marozia rests chiefly on the word of a careless, spiteful relator of indiscreet gossip' (quoted by Williams, 1998, p.11).

²⁴ For a discussion of the relationship between Benedict VII and the Crescenzi, see Toubert (1973a, p.1028, note 2).

²⁵ Poole (1917b, pp.467-469), discusses in some detail whether this pope should be called Octavian or John. The chroniclers and annalists disagree, and it is unlikely that that the controversy will ever be resolved.

8 Stephania (I) liv. 945, *senatrix* 970, *domina* of Palestrina

Sources: Poole (1917c, p.230, note 3).

Notes: Here I depart from Toubert and follow Poole's convincing chronological argument²⁶. Whether Stephania (I) and Stephania (II) were indeed mother and daughter remains unproved.

9 Marozia (II) liv. 945, *excellentissima femina atque senatrix omnium Romanorum*, 961. Died in or shortly before 979

Sources: Poole (1917c, pp.230-234).

Notes: Poole has satisfactorily established Marozia's parentage.

9a Theophylactus (II) *Vestarius, consul et dux* 927, 942, 949²⁷, died shortly before 955²⁸

Sources: Poole (1917c, p.230).

Notes: There is no proof that he was the son of Theophylactus (I), as Gerstenberg and Teofilatto have suggested, or the son of Albericus II (Williams, Table I, p. 12).

10 Theodora (III) m. c 934, liv. 951, *senatrix omnium Romanorum*

Sources: Skinner (1995, pp.48-49); Teofilatto (1982, pp.226-227).

Notes: Apparently she was instrumental in organising the ducal library in Naples (Teofilatto)

10a Johannes (III) Duke of Naples, liv. c 940 – c 969

Sources: Skinner (1995, pp.48, 49).

Notes: Unfortunately, we lack the sources to establish a firm chronology, let alone a genealogy, of the Neapolitan dukes²⁹.

?11 **John XIII** **Pope, 965-972**

Sources: Kelly (1986, pp.129-130)³⁰.

Notes: Bishop of Narni (Umbria) before his elevation.

²⁶ 'Stephania the sister of Marozia II can hardly be the wife of Benedict comes; for Benedict and Stephania are mentioned as together in 987... whereas Stephania – as I conjecture, her mother – appears in 970 with children and grandchildren, but with no husband named'.

²⁷ See Fedele (1910, pp.210-211, especially note 6).

²⁸ See Toubert (1973a, p.1215, note 1).

²⁹ Fig 2.4 on p.48 of Skinner (1995) illustrates the many problems.

³⁰ Puzzlingly, Kelly states emphatically that John XIII was '... not related, as is often supposed, to the powerful Crescentii ...'. (p.129). It is generally accepted that he was (Toubert, 1973a, p.1009, note 2). Gregorovius (vol. 3, p.358, note 2) accepts that John and Stephania (I) were brother and sister.

- 12** Crescentius (I) 'de Theodora' *Consul et dux, illustrissimus, comes et rector territor. Sab(inae)*, liv. 967, 977, d. 984
- Sources:** Romeo (1984c), Gregorovius (1894-1902, vol. 3, pp.382-386)
- Notes:** After his insurrection against Pope Benedict VI (summer 974), he seems to have retired to his fortress near Velletri and in 891 to the monastery of San Alessio all'Aventino (Romeo, p.665) where he died. An inscription there records his parents as Johannes and Theodora.
-
- 12a** Sergia d. before October 989
- Sources:** Romeo (1984b, p.661) *Illustrissima*
- Notes:** '...di nobile famiglia...' (Romeo, 1984c, p.664). She is named in a document of 989 as the mother of Joammnes and Crescentius (Gregorovius, vol. 3, p.386).
-
- 13** ? Stephania (II) liv. 987, *illustrissima femina, senatrix omnium Romanorum, comitissa*
- Sources:** Poole (1917c, p.230, note 3); Romeo (1984a, p.657); Müller (1930, pp.18-19).
- Notes:** See No 8 Stephania (I), and Gregorovius (vol. 3, p.295, note 2).
-
- 13a** Benedictus (I) 'Campaninus' *Comes et rector of the Sabina*, liv. 965/7-985/7. Died in or around 1005³¹
- Sources:** Poole (1917c, p.230, note 3); Romeo (1984a, p.657); Kölmel (1935)³²; Gregorovius (vol. 3, pp.436-438).
- Notes:** Ancestor of the Crescenzi 'Stefaniani'. See Table II, p.1086 in Toubert (1973a)³³.
-
- 14** Johannes (I) Crescentius *patricius urbis Romae* c.985, d. 988
- Sources:** Romeo (1984c, p. 664); Gregorovius (vol. 3, pp.399ff).
-
- 14a** Theodora liv. last quarter of the tenth century
- Notes:** Her origins are not known.
-
- 15** Crescentius (II) Nomentanus Born c 950, *patricius, senator omnium Romanorum*, liv. 985, 988, 991, count of Terracina, d. 998
- Sources:** Romeo (1984b); Gregorovius (vol. 3, pp.407-434).
- Notes:** Ruler of Rome from around 991 to 996 when he was exiled, but never *princeps*. He deposed and exiled Gregory V, the candidate and cousin of emperor Otto III, later in 996. The emperor returned to Rome, deposed the antipope John XVI,

³¹ See the document cited by Gregorovius (1894-1902, vol. 3, pp.300-301, note 1).

³² Kölmel (1935) provides a useful list of the counts and rectors of the Sabina from 967 to 1109, insofar as they can be traced.

³³ His son, Benedictus (II) married Theodoranda, sister of Crescentius, count of Terracina (liv. c 988-999). See Skinner (1995, pp.175-177) and Gerstenberg (1937-39).

beseiged Crescentius in the Castel Sant' Angelo, captured him and had him beheaded³⁴.

16 Johannes (II) Crescentius *Patricius Romanorum, Praefectus* 1003, d. before 27 March 1012

Sources: Romeo (1984b, p. 661); Gregorovius (4/1, pp.4-13).

Notes: '...patrizio e dominatore della città dal 1004 al 1012 ...' (Romeo, 1984b, p.661). The rule of the Crescentii ended with his death, and the family of the counts of Tusculum took over.

17 Rogata *Senatrix*, liv. 1006, 1007, 1013

Sources: Romeo (1984b, p. 661); Toubert (p.1277, note 4); Müller (1930, p.24)

Notes: Rogata gives the names of her brother and father in a Farfa Diploma, cited by Gregorovius (vol. 3, page 295, note 1): '... *pro anima Johannis Patricii Romanor. germani mei, et Senioris nostrī*.'

17a Octavianus liv. c 1005-1013, count of Sabina

Sources: Müller (1930, pp.24-26, especially note 238).

Notes: Son of Joseph, *dux et rector Sabinensis* (d. before 982), ancestor of the Crescenzi 'Ottaviani'. See Table IV, p.1087 in Toubert (1973a)³⁵.

18 Marozia (IV) Died in or shortly after November 1056

Sources: Müller (1930, p.26, notes 244 & 247).

Notes: Her will was dated 1056 (Gregorovius, 4/1, p. 19, note 1).

18a Gregorius Count of Ceccano and Segni, liv. early to mid eleventh century

Sources: Müller (1930, p.26, note 247).

Notes: Gregorius was the son of Amatus, *comes Campaniae*, c 1010 (Gregorovius, 4/1, p. 19, note 1).

19 Crescentius (III) Count and rector of the Sabina, liv. 1024, 1035/6, 1047, d. before 1061

Sources: Kölmel (1935); Müller (1930, pp.24-25 & 26, notes 241 and 247).

19a Theodora Died after 1062

Sources: Müller (1930, p.26, notes 241 and 249)

Notes: Her family origins are not known.

³⁴ A wife attributed to Crescentius, Stephania, is almost certainly apocryphal (Gregorovius, vol. 3, pp. 432-433).

³⁵ His ancestry is given in Toubert (1973b).

- 20** Ota liv. 1035
Sources: Müller (1930, p.26, note 245).
Notes: '... constat me Otam honestam feminam relictam bonae memoriae Ogerii et filiam cuiusdam Rocciae [Rogatae] ... pro redemptione ... animae ... et domni Octaviani genitoris mei ...' (*Il Registro di Farfa*, IV, 97, a. 1035), cited in Müller.
-
- 21** Oddo/Atto Count and rector of the Sabina, liv. 1003/6–1035/6
Sources: Kölmel (1935); Müller (1930, pp.27-28).
-
- 21a** Doda of Marsica liv. 1011
Sources: Howe (1997, pp.98-99, 181); Sennis (1994); Müller (1930, p.26, note 242)
Notes: She was the daughter of Rainaldo I, count of Marsica (c 968-1000) apparently by his second wife Jesulfa/Gervisa of Chieti
-
- 22** Johannes liv. 1056
Sources: Müller (1930, p.26, note 243).
-
- 23** Gregorius (I) *Consul et dux, 961, vir illustrissimus 980, praefectus navali, 999 count of Tusculum d. before 1013*
Sources: Poole (1917c, p. 230).
Notes: Poole (1917c, especially Appendix, 'The counts of Tusculum'). See also Carpegna Falconieri (1997).
-
- 23a** Maria d. before 1013
Sources: Poole (1917c, p.230); Gregorovius (4/1, p.15, note 1).
Notes: Of unknown parentage
-
- 24** Albericus (III) *Consul, eminentissimus consul, dux et patricius, praefectus navalis, count of Tusculum, liv. 999, 1013, 1028, d. c 1044*
Sources: Poole (1917c, p.230); Herrmann (1973); Toubert (pp.1208-1209, note 5).
Notes: Effectively ruler of Rome, after the death of his father Gregorius sometime before 1013.
-
- 24a** Ermelina liv. c early to mid eleventh century
Sources: Herrmann (1973).
Notes: Of unknown parentage
-
- 25** (Theophylactus III), Benedict VIII Pope, 1012-1024
Sources: Kelly (1986, pp.139-141).
Notes: For his chronology, see Poole (1917a, p.207).
-

26 (Romanus) John XIX Senator omnium Romanorum, then **Pope, 1024-1032**

Sources: Kelly (1986, pp.141-142).

Notes: For his chronology, see Poole (1917a, pp. 207-208)³⁶.

27 Marozia (III) Living in third quarter of tenth century

Sources: Feller (1998, pp.628, 630-631).

Notes: Alberic (III) had a sister called Marozia (Toubert, 1973a). I speculate that she was the first wife of Trasmundus of Spoleto. One of her grandsons was called Alberico, suggesting a connection with the house of Theophylactus³⁷.

27a Trasmundus II³⁸ Marquis of Spoleto, c 969-979

Sources: Feller (1998, pp.615-616, 630-631)³⁹.

Notes: Trasmundus II married secondly Berta, whose family is unknown (Feller, pp.628, 631).

28 (Theophylactus IV), Benedict IX Pope, 1032/33-1044; 1045; 1047-1048⁴⁰

Sources: Kelly (1986, pp.142-144); Poole (1917c, *passim*).

Notes: For his chronology, see Poole (1917a, pp. 209-210). Poole (1917c) tries to reconstruct the complicated succession of popes between 1044 and 1046.

29 Gregorius (II) *Consul, senator, dux, patricius*, count of Tusculum

Sources: Poole (1917c, p.230); Herrmann (1973).

Notes: He seems to have taken power in Rome about the same time that his younger brother Theophylactus (IV) became pope.

30 Ottavianus liv. 1033, 1056

Sources: Herrmann (1973).

31 Petrus *Consul, dux, senator* 1056

Sources: Herrmann (1973).

³⁶ At his election, Romanus seems not to have been a member of the clergy, and may have obtained office by bribery (Williams, 1998, p.19), as well of course through his family connections.

³⁷ Moreover, the dates fit very well, and there was, to my knowledge, no other Marozia around at the time. Herrmann (1973) provides her with a son Petrus, bishop of Silva Candida (liv. c 1026-1049).

³⁸ See the genealogical table of the Attonids in Feller (1998, p.621).

³⁹ See also Müller (1930, pp.80-92): II. 'Die Grafen von Chieti aus dem Hause der Attonen' for a list of sources.

⁴⁰ With Benedict XI, according to Gregorovius, conditions in Rome '... would be found to surpass in wickedness the later times of the Borgias', (*op. cit.*, vol. 4/1, p.42).

- 32** Attone (IV) Count of Chieti, liv. 1017-1034
Sources: Feller (1998, pp.616-617, 623).
-
- 32a** Agata Living first quarter of the eleventh century
Sources: Feller (1998, p.641).
Notes: Her parentage is not known. She was the mother of Attone's children, Albericus (IV), Purpura and Attone (V).
-
- 32b** Gisla Living in the second quarter of the eleventh century
Sources: Feller (1998, p.641, note 194).
Notes: Her parentage is not known. She was probably the mother of Attone's youngest son, Trasmundus (III) count of Chieti.
-
- 33** Theodora (I) liv. 1038–1060, d. before 1100
Sources: Herrmann (1973); Fedele (1905, *passim*)
Notes: Her marriage, probably around 1038 (Fedele, 1905, p.16), was noted in the *Codex Diplomaticus Cavensis* (Fedele, p.5, note 1).
-
- 33a** Pandulfus/Paldulf of Salerno *dominus* of Capaccio, liv. 1047, assassinated 1052 with his brother, prince Guaimar IV
Sources: Taviani-Carozzi (1991, p.371); Fedele (1905, *passim*).
Notes: Amalfitanian insurgents secured the support of Gaimar IV's four brothers-in-law, sons of the count of Teano, who murdered them both and took control of Salerno (Norwich, 1981, p.87).
-
- 34** Albericus (IV) liv. 1028
Sources: Feller (1998, p. 617).
Notes: He is mentioned only once and may have died young.
-
- 35** Purpura d. before 1049
Sources: Feller (1998, p. 617).
Notes: Her name suggests that she was from the ducal house of Amalfi.
-
- 36** Attone (V) count of Chieti –1059-
Sources: Feller (1998, pp.617-618, 624-625).
Notes: He was murdered by his younger brother, Trasmundus (III) who succeeded him.
-
- 36a** Gaitelgrima of Marsica
Sources: Feller (1998, p.641, note 242).
Notes: Daughter of Oderisius II, count of Marsica (liv. c 1054-after 1077); murdered with her husband.

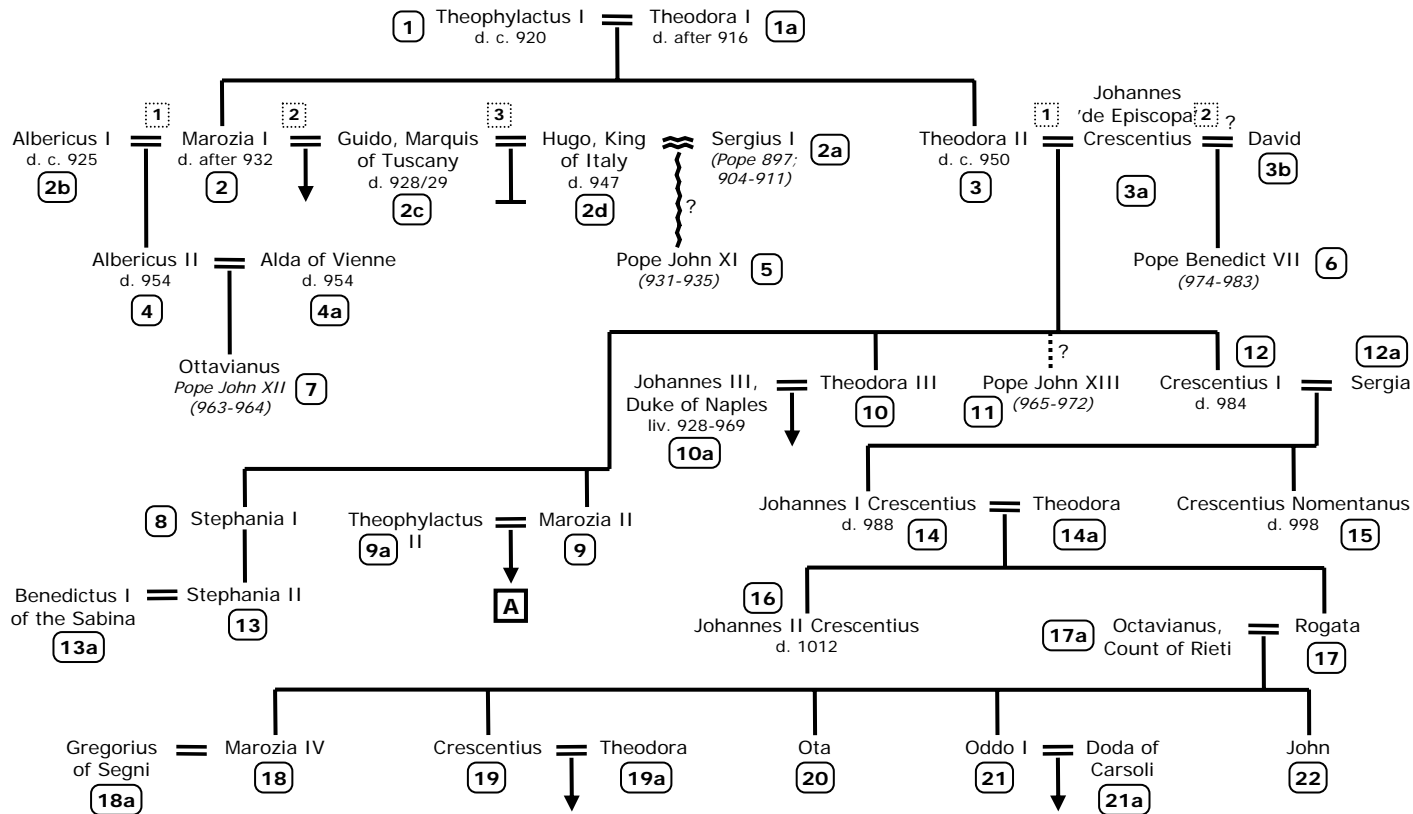

Fig 1. Selected descendants of Theophylactus I

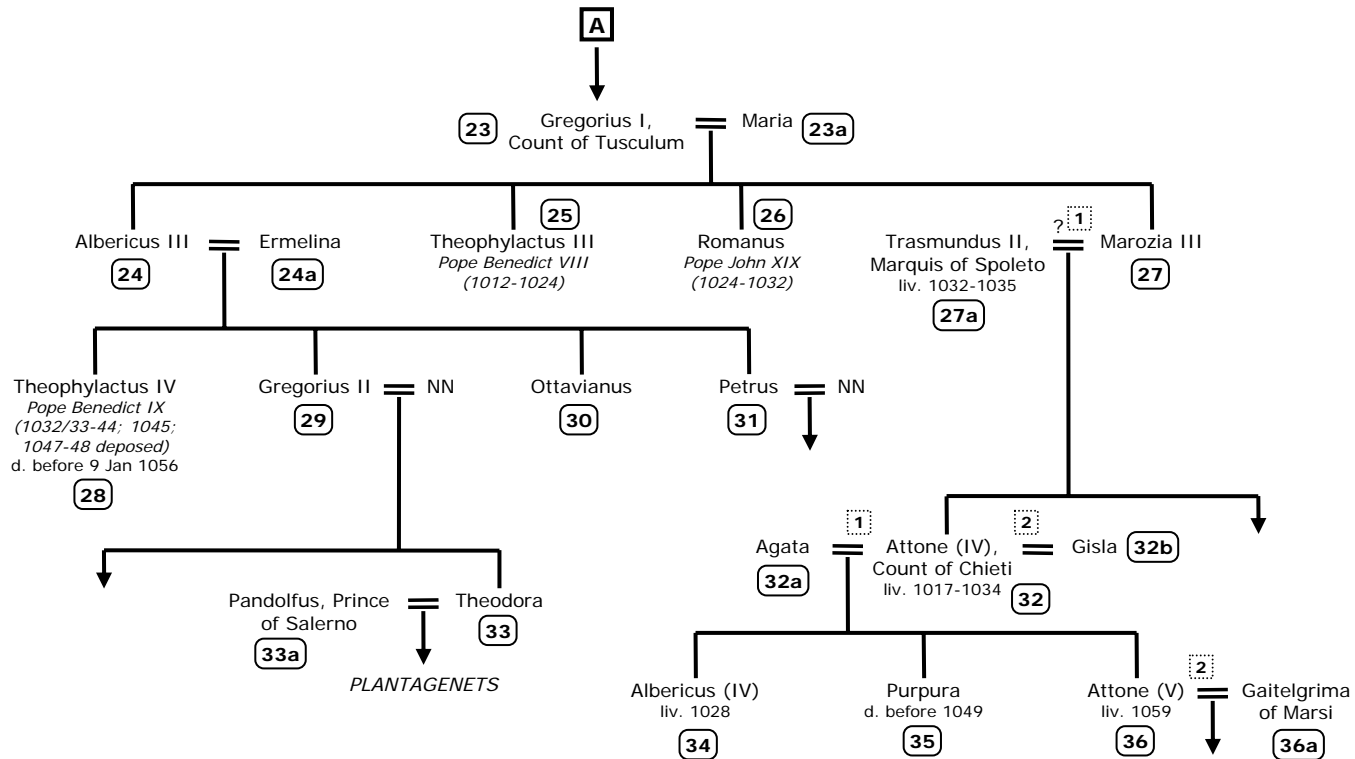

Fig 2. Selected descendants of Gregorius I

References

- Arnaldi, Girolamo (1960a). Alberico di Roma, *Dizionario Biografico degli Italiani*, Rome, **1**: 647-656.
- Arnaldi, Girolamo (1960b). Alberico di Spoleto, *Dizionario Biografico degli Italiani*, Rome, **1**: 657-659.
- Carpegna Falconieri, Tommaso di (1997). Tusculum, Gf. En v. In: *Lexikon des Mittel Alters*, 8. Munich, pp.1122-1123.
- Cecchelli, Carlo (1935). Note sulle famiglie Romane fra il IX e il XII secolo. *Archivio della Reale Deputazione Romana di Storia Patria*, Rome, **58**.
- Drell, Joanna H (2002). *Kingship and Conquest. Family Strategies in the Principality of Salerno during the Norman Period, 1077-1194*. Ithaca/London.
- Fedele, Pietro (1905). Di alcuni relazioni fra i conti del Toscolo ed i principi di Salerno. *Archivio della Reale Società Romana di Storia Patria*. Rome. **28**: 5-21.
- Fedele, Pietro (1910 & 1911). Ricerche per la storia di Rome e del papato al. sec. X. *Archivio della Reale Società Romana di Storia Patria*, **33**: 177-247; & **34**: 75-116, 393-423.
- Feller, Laurent (1998). *Les Abruzzes Médiévales: territoire, économie et société en Italie centrale du XIe au XIIIe siècles*. Rome.
- Gasparrini Leporace, T (1938). Cronologia della duchi di Spoleto (569-1230). *Bollettino della Regia Deputazioni di Storia Patria per l'Umbria*, **35**.
- Gerstenberg, Otto (1937-39). Studien zur Geschichte des Römischen Adels am Ausgange des 10. Jahrhunderts. *Historische Vierteljahrschrifte*, **31**: 1-26.
- Gregorovius, Ferdinand (1894-1902). *History of the City of Rome in the Middle Ages* (4th edition). Translated by Hamilton, Annie. London.
- Herrmann, Klaus-Juergen (1973). *Das Tuskulanerpäapsttum (1012-1046)*. Päpste und Päpsttum, Band 2. Stuttgart.
- Howe, John M (1997). *Church Reform and Social Change in Eleventh-century Italy: Dominic of Sora and his Patrons*. Philadelphia, PA.
- Kelly, John N D (1986). *The Oxford Dictionary of Popes*. Oxford/New York.
- Kölmel, Wilhelm (1935). Rom und der Kirchenstaat im 10. und 11. Jahrhundert bis in die Anfänge der Reform. *Anhandlungen zur Mittleren und Neueren Geschichte*, Berlin, **77**.
- Kurtz, Johann Heinrich (1860). *History of the Christian Church to the Reformation*. Translated by Edersheim, A. Edinburgh.
- Llewellyn, Peter (1971). *Rome in the Dark Ages*. London.
- Mann, Horace K (1925). *The Lives of the Popes* (18 vols.). London.
- Müller, Hermann (1930). *Topographische und genealogische Untersuchungen zur Geschichte des Herzogtums Spoleto und der Sabina von 800 bis 1100*. Inaugural-Dissertation zur Erlangung der Doktorwürde der Philosophischen Fakultät der Universität Greifswald. Greifswald.

- Norwich, John Julius (1981). *The Normans in the South, 1016-1130*. London.
- Poole, Reginald L (1917a)⁴¹. Papal chronology in the eleventh century. *English Historical Review*, London, **32**: 204-214.
- Poole, Reginald L (1917b)⁴¹. The names and numbers of medieval popes, *English Historical Review*, London, **32**: 465-478.
- Poole, Reginald L (1917c)⁴¹. Benedict IX and Gregory VI. *Proceedings of the British Academy*, London, **8**: 199-235.
- Romeo, Carlo (1984a). Crescenzo. *Dizionario Biografico degli Italiani*, Rome, **30**: 657-659.
- Romeo, Carlo (1984b). Crescenzo Nomentano. *Dizionario Biografico degli Italiani*, Rome, **30**: 661-664.
- Romeo, Carlo (1984c). Crescenzo de Theodora. *Dizionario Biografico degli Italiani*, Rome, **30**: 664-665.
- Sennis, Antonio (1994). Potere centrale e forze territorio di frontiera: la Marsica tra I secoli VIII e XII. *Bollettino dell'Instituto Storica Italiano per il Medio Evo*, Rome, **99** (2): 1-77.
- Skinner, Patricia (1995). *Family Power in Southern Italy. The Duchy of Gaeta and its Neighbours, 850-1139*. Cambridge Studies in Medieval Life and Thought, **29**. Cambridge.
- Taviani-Carozzi, Huguette (1991). *La Principauté Lombard de Salerne*. Mélanges de l'École Française de Rome, **152**. Rome.
- Teofilatto, Pietro (1982). Contributo alla storia della famiglia Teofilatto. *Studi Meridionali*, **15**.
- Toubert, Pierre (1973a). *Les Structures du Latium Médiéval. Le Latium méridional et la Sabine du IXe siècle à la fin du XIIe siècle*, 2 vols. Bibliothèque des Écoles Françaises d'Athènes et de Rome, **221**. Rome.
- Toubert, Pierre (1973b). *Une revision: le principat d'Alberic de Rome (932-954)*. Bibliothèque des Écoles Françaises d'Athènes et de Rome, **221**. Rome.
- Williams, George (1998). *Papal Genealogy*. Jefferson.
- Werner, Karl F (1967). Die Nachkommen Karls des Großen bis um Jahr 1000. In: Braunfels, Wolfgang & Schramm, Percy Ernst, *Karl der Grosse, Band IV: Das Nachleben*. Düsseldorf: pp.403-484 and folding table.

⁴¹ These three articles were reprinted in Poole, Reginald L (1969). *Studies in Chronology and History*. [collected and edited by Lane Poole, Austin: reprint of the 1934 edition].

Appendix

Popes in a violent era, 872-1048

Those whose reign was not seriously challenged and whose death was apparently peaceful are omitted from this inventory. Information is provided mainly by Kelly (1986). Antipopes⁴² are italicised. We start with the first pope to be assassinated.

Name	Dates	Vicissitudes and Fate
John VIII	872-882	According to the <i>Annals of Fulda</i> , he was poisoned by members of his entourage and then clubbed to death ⁴³
Hadrian III (St.)	884-885	'Foul play has been suspected and it is significant that his body was not brought back [from S. Cesario sul Panaro] to Rome ...'
Formosus	891-896	Apparently died peacefully, but nine months after his death his corpse was exhumed (January 897), dressed in papal vestments, enthroned, tried on a range of charges in the so-called 'cadaver synod', mutilated and thrown into the Tiber
Stephen VI	896-897	Presided over the 'cadaver synod' that arraigned Formosus. Deposed by the Roman mob, gaoled and soon after strangled ⁴⁴
Romanus	897	Reigned for four months, almost certainly deposed; then tonsured
Leo V	903-904	Deposed in a coup by the antipope Christopher and imprisoned; strangled on the order of Pope Sergius III
<i>Christopher</i>	<i>903-904</i>	<i>Deposed and soon afterwards strangled, along with Leo V, on the order of Pope Sergius III</i> ⁴⁵
John X	914-928	Deposed 'allegedly by popular demand', imprisoned and died in 929, either suffocated, strangled or starved to death
John XI	931-935	Kept under virtual house-arrest 932-935 by his half-brother, Albericus, princeps Romanorum
Stephen VIII	939-942	Deposed by Albericus, prince of Rome; some reports say he was imprisoned, mutilated and died of his injuries
John XII	955-963; 964	Deposed in a synod in December 963; restored in February 964. Fled into exile and died of a stroke, 'allegedly while in bed with a married woman named Stefanetta', in May later that year
Leo VIII	963-964; 964-965	Deposed and excommunicated by John XII in February 964; reinstated in June 964

⁴² There is no convenient definition of antipopes, since the designation depended upon the prevailing politics of the time and later upon a self-serving wish to re-write history. Poole (1917b, pp.473-474) provides an elegant and succinct summary of the problem.

⁴³ '... prius de propinquo suo veneno potatus, deinde - malleolo, dum usque in cerebro constabat, percussus expiravit'.

⁴⁴ The account of his death by Flodoard of Rheims is quoted by Gregorovius (vol. 3, p.229).

⁴⁵ '... in a space of only eight years, eight popes had been elected and overthrown, a striking testimony to the horrors of civil war in Rome.' Gregorovius (vol. 3, p.243).

Benedict V	964	Deposed in June 964 ⁴⁶ and died in exile in Hamburg in July 965
John XIII	965; 966-972	Assaulted, imprisoned, then banished in December 965; reinstated in November 966
Benedict VI	973-974	Deposed, then strangled on the orders of his successor, Boniface VII (presumably with the complicity of Crescentius I)
<i>Boniface VII</i>	<i>974; 980-981; 984-985</i>	<i>Deposed and excommunicated in 974; re-established himself temporarily in summer 980, and again in April 984. Upon his sudden (and probably violent) death in 985, the Roman mob stripped his corpse, stabbed it and trampled upon it.</i>
Benedict VII	974-980; 981-983	Ousted briefly by Boniface VII, summer 980 – spring 981, but reinstated and apparently died peacefully
John XIV	983-984	Assaulted, deposed and imprisoned on the orders of Boniface VII; either poisoned or starved to death in the Castel Sant'Angelo
John XV	985-996	Briefly ousted in 995 by the nobility and clergy, angered by his rapacity and nepotism
Gregory V	996-999	Driven out of Rome in October 996; restored in February 997; died in February 999, not by poison but from malaria
<i>John XVI</i>	<i>997-998</i>	<i>Usurped the papacy in February 997. Overthrown in February 997, blinded, horribly mutilated and paraded around Rome, 'sitting back to front on an ass'. Died in a monastery in 1001</i>
Sergius IV	1009-1012	His disappearance [with that of Crescentius II at a time of violent political upheaval] has 'given rise to the suspicion that neither man may have died a natural death'
Benedict IX	1032-1044; 1045; 1047-1048	'His personal life ... was scandalously violent and dissolute ⁴⁷ , as a result of which he was briefly expelled from Rome in 1045, reinstated but then abdicated (in 1047 formally deposed). After bribing his way back into power in November 1047, he was finally ejected in July 1048, dying in 1055/1056. See also, Poole (1917c, <i>passim</i>).
Silvester III	1045	Excommunicated and expelled by his rival Benedict IX in March 1045. Died 1062/1063
<i>Gregory VI</i>	<i>1045-1046</i>	<i>May have bribed Benedict IX to abdicate in May 1045. Deposed in December 1046, imprisoned and exiled to Cologne where he died in late 1047</i>

⁴⁶ Allegedly, Pope Leo VIII had him deprived of his papal garments, and broke the papal sceptre over his head (Williams, 1998, p.15, apparently following the eye-witness account of Liutprand of Cremona).

⁴⁷ It should be noted, though, that some of the most scurrilous details come from the *Liber ad Amicum* of Bonizo, bishop of Sutri, a writer 'quite without scruple in falsifying facts which did not suit his opinions' (Poole, 1917c, p.210). That Benedict IX tried to marry while still in office may have been 'a simple slander' (*ibid.*). Though elected young to the papacy, Benedict was certainly not ten or twelve years old as stated by the chronicler, Rodolf Glaber (Poole, 1917c, pp.215-218).