

PART TWO: ARMAMENT

The Future Combat System (FCS):

Technology Evolution Review and Feasibility Assessment

by Asher H. Sharoni and Lawrence D. Bacon

(This is the second in a series of three articles exploring a conceptual future combat system. -Ed.)

Main Gun Armament Evolution and Technology Assessment

This article will examine the potential main and secondary armament systems for the FCS in view of their forecasted technologies, their feasibility, and their predicted evolution:

Conventional 120/140mm Guns

A major consequence of the diminished urgency to develop novel guns in the near foreseeable future is that conventional, Solid Propellant (SP) guns will remain in service for many years to come, and their lethality will be gradually enhanced. This was the predominant reason behind the selection of the 120mm high-pressure gun for the FMBT. The typical High Velocity Armor Piercing Fin Stabilized Discarding Sabot (HV-APFSDS) projectile has been successively improved over the last three decades with suggested near-future penetration capability of up to 800-900⁺ mm of Rolled Homogenized Armor (RHA). This was primarily achieved by a progressive increase of the geometrical ratio 'Length/Diameter' (L/D) of relatively long and slender rod penetrators and continuous improvements to their corresponding materials (Tungsten Alloys, Powder Metallurgy-PM, Depleted Uranium-DU, and Variable Density Penetrators-VDP).

Penetrators with high 'L/D' ratios proved effective against RHA but they were found *considerably* less effective against composite and/or complex armor. To augment its effectiveness against the latter, the penetrator rod must have a larger diameter. Without reverting to lower and adverse ratios of 'L/D' (approximately 20/1 for 120mm and experimental 140mm and still increasing), it

must ultimately result in an increase of volume and mass of the penetrator rod and therefore, inevitably, in a corresponding undesirable reduction of the effective muzzle velocity. Utilization of progressively heavier rod penetrators to defeat contemporary and ever-improving armor protection required higher muzzle energy [presently 18-20 megajoules (MJ)]. Consequently, it led to guns with ever-increasing chamber pressures and likewise, larger gun calibers (90, 105, 120, 140mm, Western preference).

No future U.S. plans have been announced in regards to the 140mm gun, Advanced Tank Cannon System - ATACS, subsequent to the untimely cancellation of the 'Block III' Main Battle Tank Program. Following a MOU previously signed in 1988 with the U.S., Giat (France), Rheinmetall (Germany), and Royal Ordnance (U.K.) are contemplating a joint venture to develop, market, and produce a standardized 140mm smoothbore/rifled gun and ammunition. The weapon system is designated by NATO as the *Future Tank Main Armament* (FTMA) and is claimed to have a significant increase in armor penetration over the standard 120mm tank gun.

Notwithstanding the 140mm gun and ammunition's indisputable potential, the larger gun size will command a bigger and heavier vehicle. If the requirement to reduce weight and volume is going to remain firm and strictly enforced, it is most unlikely that the 140mm gun and heavy ammunition will find their way into the FCS. Furthermore, because of the major changes required and the high cost involved in upgunning the M1 Abrams tank from 120 to 140mm (storage, autoloader, and turret/hull reconfiguration), it is highly doubtful whether the 140mm gun will ever be utilized in any future upgrade to the M1 tank series. Grounded on the author's personal work experience with the ill-fated 'Block III' Tank Program, a 140mm main armament system could only be successfully inte-

grated into an entirely new tank (turret and hull) that is built around the main armament system. It will weigh at least as much as contemporary heavy tanks (70⁺ tons). The changes would also increase vehicle mechanical complexity and significantly reduce ammunition complement. This scenario is entirely unacceptable under the FCS's current prevailing philosophy. But the 140mm gun could become a valid and *urgent* proposition if the U.S. encounters a major threatening rival, similar to the U.S.S.R. during the cold-war era, within the next 10-20 years, prior to the deployment of the FCS.

The following improvements are feasible in the short term and make the 'generic' 120mm M256 smoothbore gun and its derivatives (e.g. XM291) viable propositions for the next three decades and beyond. Extraction of more energy from the propellant gases by increasing the effective length of the gun barrel up to 55 calibers long is a viable alternative, but it will not yield dramatic results. For instance, the 120mm L55 gun developed by Rheinmetall (Germany) for the Leopard 2 MBT, is 1.30 m longer(!) than its predecessor, the standard L44 Rh120 120mm smoothbore gun. The L55 gun will provide a moderate incremental higher muzzle velocity, resulting in improved armor penetration. Notwithstanding its benefits, it will definitely make it more difficult for the Leopard to maneuver in heavily built-up areas or cross-country terrain textured with densely grown vegetation or other ground obstacles.

The XM291 gun is a spin-off of the dual-caliber approach previously adopted by the U.S. Army. It was developed by the Army Armament Research, Development and Engineering Center (ARDEC) in collaboration with Watervliet Arsenal, and is a combination of a common reinforced 120/140mm high-pressure breech/chamber with a light 120mm gun tube. This newly designed "Lightweight 120mm

Tank Main Armament System," could yield comparable results to the 140mm gun at the lower performance range of the latter. Another improvement in gun performance could be obtained by the use of propellant with greater surface burning progressivity, which generates higher pressure gradients to propel projectiles. An additional increase in gun performance could come from a reduction in the temperature sensitivity of propellants, which will allow the increase of burning rates at lower temperatures. Maximum allowable chamber pressure at normal and high temperatures can be raised by employing higher strength improved steels commonly utilized in construction of gun barrels.

Advanced 120mm KE penetrators, Sensor Fused Weapons (SFW), Smart tank munitions and Smart Top Attack Weapons^{1,2} (STAW) will soon be introduced into the inventory. These munitions have extended autonomous capabilities such as independent target acquisition, identification, prioritization, maneuver control, and improved lethality.

One representative candidate is the Defense Advanced Research Projects Agency (DARPA) M872 'X-Rod' Rocket-Assisted KE (RAKE) long rod penetrator that defeats targets with kinetic energy and could achieve a boosted 'muzzle' velocity of 2000 m/sec. Another is the XM943, Smart Target Activated Fire and Forget (STAFF) top-attack round, which kills with a downward firing, non-axis symmetric, Explosively Formed Penetrator (EFP). The STAFF is designed to penetrate the thinner turret roof armor and lightly armored tank top deck. The guided round's sensor and explosively formed penetrating warhead are capable of destroying evasively maneuvering armored targets that attempt to make use of terrain texture and defilade.

The M829E3 is a dramatically improved kinetic energy (KE) round developed to defeat advanced explosive reactive armor. The Advanced KE Cartridge Program is about developing a round with composite sabots, precursor, axial thruster assembly, and *fastcore OXETANE/CL20* propulsion. It will have improved performance over the standard M829A1/A2 rounds in defeating Explosive Reactive Armor (ERA) and penetrating Rolled Homogeneous Armor (RHA), and greater hit probability. Categorically, these types of advanced munitions will further extend the useful life of the 120mm solid propellant gun.

These improvements, impressive as they are, will probably not lead the way to the FCS's main antitank armament due to large caliber burden, ammunition vulnerability, and the inherent limited growth potential of solid propellants (SP). According to basic governing thermodynamic laws, the velocity at which chemical SP could accelerate a projectile is controlled by the velocity at which a gas could physically expand. For all practical purposes, contemporary 120mm guns may ultimately reach a muzzle velocity of 1800-2000⁺ m/sec. Future 140mm guns (if fielded) may reach an extended muzzle velocity of 2100-2300⁺ m/sec while their effective 'kill' range will not exceed 6-7 km at best.

With industrial and logistic infrastructures already in place, backed by battle-field-proven technology, conventional 120mm guns will remain the 'backbone' system in service for the next 20-30 years and beyond. They will progressively continue to receive incremental improvements until replaced, while allowing sufficient time for a new main armament weapon system to mature. The 120mm main armament gun system, though extremely potent in its own right, will not justify the enormous expenditure in development, production, and deployment of a new tank. It will serve as the standard gun of existing M1A1/A2s, and as an indisputable, cost-effective upgrade for tanks that are equipped with an inferior caliber gun (105mm). Regardless of how SP guns will ultimately evolve, both users and the defense research community have concluded that solid propellants are not the most efficient medium of conveying to a projectile the energy required to defeat the ever-evolving threat. Consequently, since the mid-80's, there has been a significant increase in Western R&D interest and research efforts aimed particularly at developing new technologies which will substitute for contemporary SP gun systems. Most of these efforts (ETC, EM, high-power laser) are descendants of the U.S. Strategic Defense Initiative (SDI) space-oriented weapons program.

Liquid Propellant Guns

Liquid Propellant (LP) gun propulsion technology is another viable alternative. Unfortunately, it has recently received untimely poor publicity when the U.S. Army finally decided it will not be implemented in the *Crusader*, the advanced self-propelled howitzer currently under

development for the U.S. Army. To the best of our information, the U.S. Army has reluctantly given up on this promising technology in *Crusader*. Ostensibly, it was compelled to make that decision because of the detrimental impact it would have on production and deployment schedules if the Army had to wait until LP technology matures enough to warrant its near-term implementation. LP technology is the outcome of extensive R&D efforts performed in several countries ever since the end of WWII.

Though LP is technologically based on a sound engineering foundation, it is presently known to experience inherent, pre-maturation, 'nagging' problems such as ignition control, excessive corrosion, combustion non-repetitiveness, sealing, exorbitant weight growth, material contamination, and difficulties in handling of LP. It may be adaptable to naval applications where better controlled environment, available space, larger guns, handling, storing, and operating LP armament systems seem more plausible. LP guns require continuous resupply of propellant working liquid, which does not conform favorably with stringent requirements for reduced logistics. LP, in conjunction with 120/140mm tank guns with regenerative, multi-stage propellant injection systems, could reach unassisted muzzle velocities up to 2200/2500 m/sec respectively at best. (It is about 10-15% higher than what could ultimately be achieved with conventional SP 120/140mm guns). This only holds true if ailing problems with "traveling charge" or "stage propellant" will be satisfactorily resolved to match the injected "charge front" propagation speed — through the entire injection process — with that of the projectile as it advances down the barrel.

It has already been demonstrated that by using a 30mm two-stage traveling-charge LP demonstrator gun, velocities as high as 3100 m/sec and beyond could be achieved. Trade-offs between projectile velocity and mass will dictate the preferred caliber for future applications. If limited vehicle weight and ammunition count are to remain the main drivers, the selected caliber of LP guns is probably not going to exceed 60-80mm with maximum muzzle velocities of up to 2500-2800 m/sec.

LP technology, though once believed to be the prime alternative to SP, is nowadays viewed as less attractive for ground mobile applications and thus may not

become the main armament for the FCS. Nonetheless, all this may dramatically change if these technical difficulties would somehow be satisfactorily resolved. As with the implementation of any novel technology, LP requires currently nonexistent industrial and military infrastructures for production, deployment, and logistics.

In spite of its temporarily recent handicap, research and development of Regeneratively Injected LP guns (RILP) for various ground and naval applications, will most likely continue.³ In all fairness, there is much to be said in favor of LP technology, despite its disadvantages. Chiefly these are its inherent growth potential and high level of design flexibility. LP guns possess controlled, variable lethality and permit a relatively larger stowed load due to improved efficiency of LP storage and reduced volumetric requirements in comparison to SP combustible solid cases. Other advantages are safer storage of LP via compartmentalization, improved piezometric efficiency, and extended barrel life due to a much cleaner and better controlled combustion process. Last, but not least, RILP technology represents a rational leverage of the substantial investment already made in the LP version of the revolutionary *Crusader*. Notwithstanding a myriad of technical and logistic problems, given sufficient time and resources, LP technology could mature to warrant its future implementation as the principal armament system in heavy armored vehicles and the FCS in particular.

Electro-Thermal-Chemical Guns

Encouraging results have been obtained with Electro-Thermal-Chemical (ETC) experimental guns. In principle, an ETC gun utilizes a chemically energetic (reactive) working liquid instead of conventional solid propellant. It requires considerably less electrical energy to achieve adequate projectile propulsion than its predecessor, the Electro-Thermal experimental (ET) gun. It needs relatively smaller and lighter auxiliary equipment to produce and store electricity. This equipment could ultimately be reduced to a suitable size to warrant its installation in an armored vehicle. Energetic working liquid is naturally prone to be problematic in operation, handling, storage, and supply, such that its utilization will pose a potential safety concern and a logistic burden, much similar to LP guns. As in LP, ETC implementation requires new industrial and military infra-

structures for production, deployment, and logistics.

Current developments are aimed at a medium caliber (60-80mm), antitank gun with a firing rate of 10-15 rounds/min. At this caliber range, various types of rounds could be comprised of KE projectiles and CE rounds, as well as future 'smart' sensor-fuzed munitions. The ultimate objective is aimed at an ETC automatic gun with a muzzle energy of 20⁺ MJ (corresponding to 2500-3000 m/sec for medium calibers) which is comparable to that of the conventional, solid propellant 140mm gun. Much like LP guns, ETC technology allows better control of the pressure (propulsion) generated, so that it is maintained relatively close to its maximum while the projectile is moving down the barrel, resulting in more energy conveyed to the projectile.

This is quite contrary to conventional SP technology, where the pressure quickly diminishes as the projectile departs from the combustion chamber. ETC technology is recognized by many to show promise of "infinite" or multi-stage variable lethality and improved propulsion controllability. It also requires significantly less electrical energy in comparison to Electro-Magnetic (EM) guns that use only electricity for projectile propulsion. Nevertheless, ETC technology, as promising as it may seem, requires further fundamental research beyond the laboratory stage. Much detailed research and testing has yet to be accomplished in the field and at weapon system level. It must achieve maturation to warrant its applicability as a stand-alone solution, or in conjunction with other mature technologies, or with existing 120/140mm guns.

As an additional practical alternative, ETC technology could be combined with existing conventional SP 120mm and/or future 140mm guns and ammunition, though a new cartridge and modified gun chamber are required. It represents a near-term upgrade application of already leveraged and proven technology. The size of the electrical equipment is much smaller than that of current EM research guns and present ETC as a viable upgrade proposition. Research has shown that specially designed ammunition and ETC gun technology could be combined with existing conventional SP guns to further enhance the performance of the latter up to 30% and beyond. Augmenting the energy of solid propellant is possible by implementing a plasma regen-

erative injector and combustion control to the conventional pressure chamber. In the event that ETC technology will become practical, existing conventional 120mm and future 140mm guns could be economically converted into ETC/SP guns as one more step in the evolution of SP guns. There are still various predominating problems to be addressed and resolved before ETC guns can become a practical proposition in conjunction with conventional solid propulsion. The combination of controllable, repeatable inner ballistics with a compatible solid propellant, and the significant increase in performance (e.g. muzzle velocity) in large caliber guns, has yet to be demonstrated.

Regardless of whether ETC technology will become a viable proposition, the use of large consumable ammunition in addition to 'energetic' liquid propellant is contradictory to the requirement of reduced dependency on logistics and weight. The combined implementation of SP with ETC, will probably not justify the enormous investment in design, development and deployment associated with the fielding of an entirely new tank fleet. Though new and promising technology, it will not change the nature of armored warfare.

Electromagnetic Guns

Electromagnetic (EM) railguns or coilguns, also known as Pulsed-Power EM guns, are expected to launch light projectiles (KE, up to 5 kg) with 30-60mm in diameter, at unprecedented hypervelocities between 4000-8000 m/sec (30-60 MJ). Contrary to conventional SP guns, the EM pulse travels at near the speed of light (@ 186K miles/sec) and thus provides propulsion means inherently immune to natural limits of gas expansion. At these extremely high velocities, EM guns are unsurpassed, being more efficient than any other type of existing gun.^{4,5} EM railguns operate on the same principle as 'linear' electric motors. The barrel consists of two (or more?) highly conductive rails with the projectile positioned between the latter and enclosed in the leading bore. As high current is supplied to the rails, a strong magnetic field is created by the electric arc across the rails which accelerates the projectile down the barrel. Hypervelocities appear to improve the effectiveness of kinetic energy projectiles against some types of homogenized armor but may not do so against others. It increases with velocity against explosive *reactive* armor if the

FCS Unmanned Weapon Station

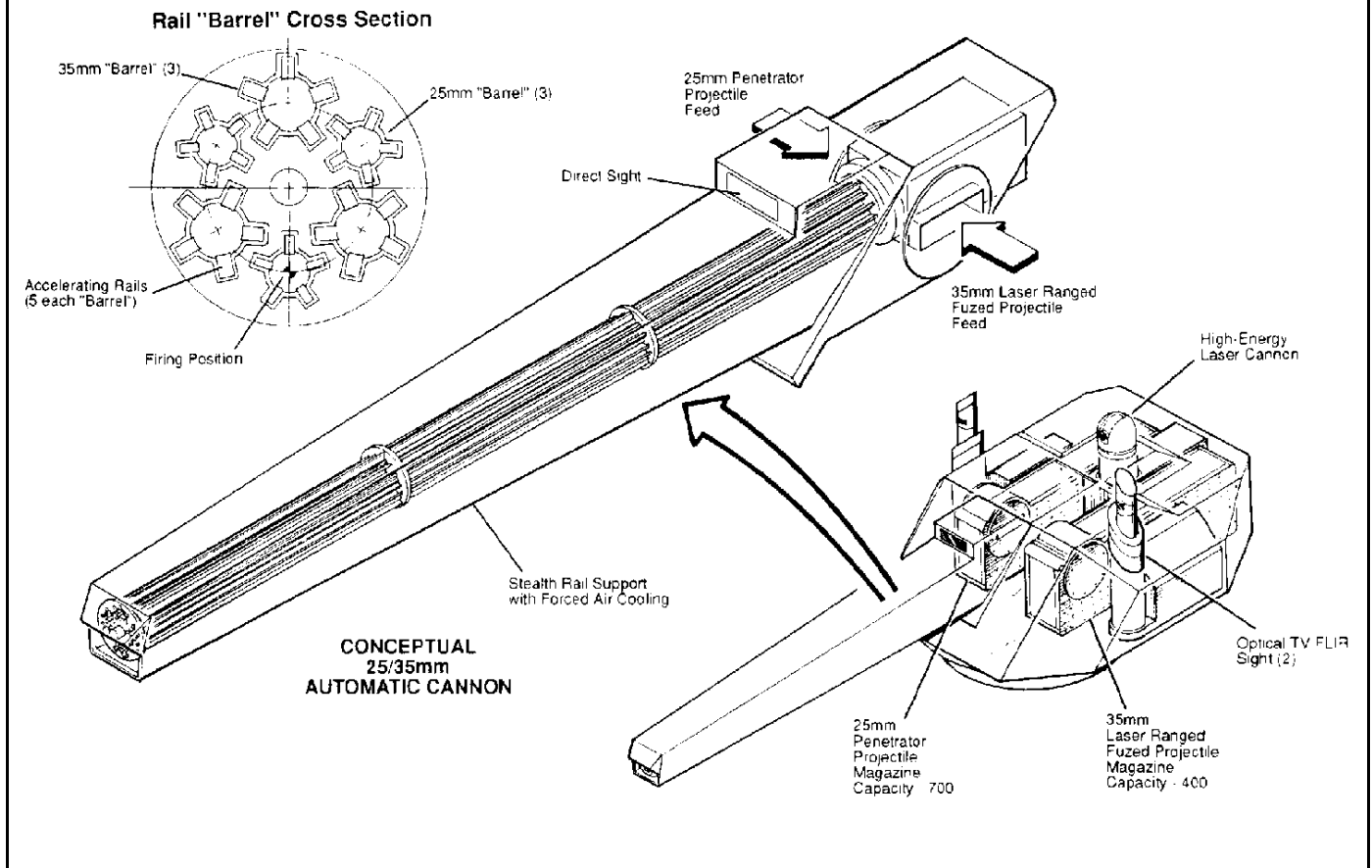

projectiles are segmented, but will not increase against a variety of complex composite armors. The benefit of hypervelocity projectiles is obvious against RHA, missiles, helicopters, and low flying ground support aircraft, but requires further development for full adaptation to antiarmor complex applications. For instance, in order to achieve muzzle energy of merely 9 MJ at velocities of 2500-4000 m/sec, a Compensated Pulsed Alternator (CPA) system that weighed 20 tons was used as recently as less than a decade ago. Considerable size, low energy density, and a multitude of unresolved technical problems indicate that EM guns still have a long way to go before they could become practical enough to be incorporated as the main gun armament in a relatively small, highly mobile weapon system such as the FCS.

Because of the high secrecy associated with outer-space military weapons applications, no recent information has been published nor released about EM guns and their applicability. Many in the research community believe that significant technical breakthroughs have been achieved over the last ten years, but have

not become public knowledge. In International Defense Review (IDR)⁴ it was reported that ARDEC and DARPA, with funding assistance from the SDI office, embarked upon a two-phase, multi-tasking joint venture, to demonstrate that both rail and coil type EM guns could repetitively fire projectiles at 2500-4000 m/sec with a muzzle energy of 9 MJ (equivalent to 120mm SP KE round). Phase I was divided into multiple tasks culminating with the construction of repetitively firing skid guns. In phase II by 1995, they were supposed to down-select one of the concepts identified in phase I, as the basis for a self-contained, vehicle-mounted 15 MJ EM gun. The mobile demonstrator vehicle was supposed to be equipped with an EM gun firing at a rate of 4 rounds in 24 sec.

Two contracts have been awarded. One to the University of Texas (UOT) under ARDEC, and the other to Maxwell Laboratories under the Defense Nuclear Agency (DNA). In 1989, it was reported that the Maxwell Single Shot Gun (SSG) was a simple bolted design, 8 m long, weighed 18 tons and had a 90mm circular bore. The associated capacitor was

rated at 32 MJ. Reportedly, Maxwell Labs succeeded in accelerating a plasma-armatured projectile weighing 1.1 kg up to 3500 m/sec, corresponding to a muzzle energy of 7 MJ. As of today, ME systems have been demonstrated with 30-35% efficiency, though 50% is the acknowledged practical maximum.

Under SDIO sponsorship, the Westinghouse Research and Development Center constructed a 56mm/60 MJ "Thunderbolt" railgun for lethality demonstrations at high-end hypervelocities. Much detail could have been reported herein about recent advancements in ME technology research if it was not considered classified information. There are still fundamental issues that must be investigated, researched, and developed before EM guns could become a practical proposition, among them: 1) Material ablation effects due to extremely high friction with the atmosphere at hypervelocities could cause the projectile to burn unevenly, resulting in substantial degradation of its ballistic trajectory accuracy, velocity attenuation, and subsequent reduction in penetration effectiveness. Materials demonstrating low ablation must

FCS Details

(MODULAR ARMOR NOT SHOWN IN THESE VIEWS)

CREWMAN MASTER CONTROL SEAT (2)
(FLY-BY-WIRE)

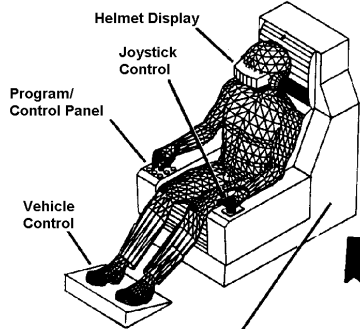

- Personal Environmental Control
- Communication
- Electronics and Interfacing Computer

Electrical Power-Pack with Energy Storage

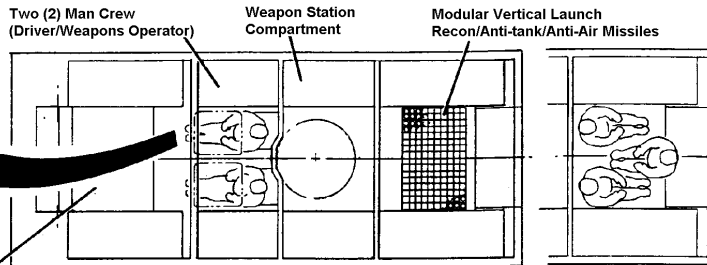
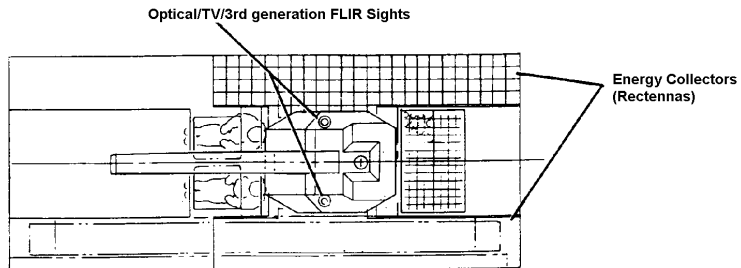
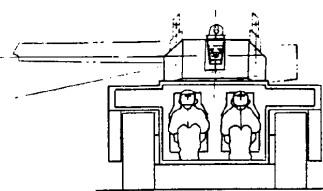

Automatic EM Dual Feed 25/35mm Cannon

Elevation Capability (+100°, -9° over Front, -12° over Side)

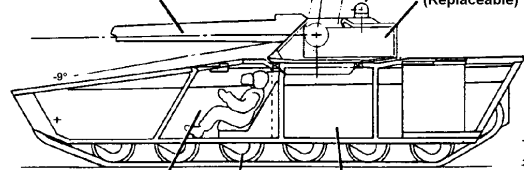

Consolidated Crew Compartment

Weapon Station Compulsators and Energy Storage Capacitors

Computerized Hydropneumatic (Dynamic) Suspension

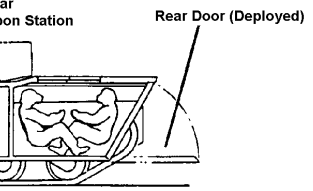

Optional Crew/Infantry Compartment

also possess high mechanical strength (hard to find); 2) Interface repulsive force between the projectile and the accelerators (rails or coils) must be determined to quantify the critical implications in safety, structural integrity and launch reproducibility; 3) Selection of gun barrel material for overall weight reduction while maintaining adequate resistance to ablation and durability; 4) Accelerations of 10^6 g's produce previously unknown and unique material problems (e.g. vaporization) with critical implications for both lethality and accuracy. [At hypervelocities, materials behave like liquids, requiring the implementation of hydrodynamics, gas thermodynamics, and compressible fluid dynamics to represent the impact interaction between the penetrator and its target]; and 5) Reduction of electrical equipment size (e.g. capacitors, compulsators, and homopolar generators) and development of coaxial inductors and first-generation, Barber repetitive opening switches operating at extremely high-current; 7) Railguns exhibit difficulty with initial acceleration. To avoid excessive heat and stress associated with the initial projectile launch phase, a method of gas-injected running-start for initial acceleration (up to practi-

cally 1 km/sec), prior to the projectile entering the railgun breech, has been developed. This method introduces mechanical complexity and additional undesired logistic burden.

Nevertheless, in spite of immense technical challenges, especially extensive pulse and power requirements for extremely short periods of time, and virtually nonexistent infrastructure, EM gun technology is the preferred long-term ultimate choice. Consistent improvements in super high-efficiency copolymer resin-based capacitors, compulsators (e.g. UOT developed 'alternator' type generating sharp-pulse shapes), homopolar generators, HPG (e.g. Faraday rotating disk requiring large inductors for sharp-pulse shaping), high energy density superconducting inductors, and very high-density EE storage devices ('super capacity'-batteries), will yield *dramatically* reduced volume and weight. Sizable computers that only 30-40 years ago filled-up enormous volume and weighed 30(+) tons, have been reduced in volume and weight into today's personal computers. There is no logical or any known physical barrier to preclude it from happening also to EM guns if driven by

high priority operational requirements, and given sufficient time and adequate resources. Ten years ago, under project Mile Run, DNA conducted research to reduce a 10 ton EM system into an affordable 1.2 ton package with 32-50 MJ copolymer resin-based capacitor technology, intended to be fitted in a tracked vehicle for ground mobile lethality and feasibility demonstrations. EM guns have reduced vulnerability and operate on electrical energy alone.

Electrical energy is much simpler to transport, handle, store, and control than any ETC or LP energizing "liquids" that require special handling and storage, and could become a paramount hazard concern. The notion of simplified logistics will further tip the scale in favor of EM guns. An FCS equipped with main systems operating *solely* on electrical energy is a tremendously reduced logistic burden. Even if friction and atmospheric attenuation will limit the antiarmor projectiles to only say, 6000 m/sec, it is still by far superior to any existing conventional gun. EM gun technology, though still in a premature stage and presumed

Continued on Page 49

high-risk in development, but with leap-ahead *variable lethality* potential through hypervelocity, is chosen as the preferred main gun armament system for the FCS.

For demonstration purposes only, our *visionary* and conceptual EM gun is constructed of six 'barrels,' three are of 25mm, and the other three of 35mm (inner diameter) for two kinds of ammunition. Each 'barrel' is comprised of five equally spaced accelerating rails which also act as cooling fins to enhance heat dissipation. Only one barrel is firing at a time, and only one type of ammunition (25 or 35mm) is being fired in every burst. The multi-barrel assembly is enclosed in a stealthy rail support structure through which ambient air is forced for cooling. The anticipated controlled variable rate of fire is from 1 to 60 projectiles/min, depending on battle conditions and availability of targets, while optimizing and conserving energy. Obviously, it is highly dependent upon the rate of electrical consumption for firing projectiles and the cooling requirements of the barrels. There are two magazines (700/25mm and 400/35mm, caseless projectiles only) on each side of the gun and each separately stores one type of ammunition. Ammunition is fed directly from the magazines to the dual feed EM gun via mechanical 'twisters' that reorient the projectiles from their original outboard position in the magazine to align them with the firing direction. There is no need for any manual loading or an autoloader since the ammunition is fed directly from the magazines to the guns.

Granted, much research has yet to be performed to overcome the present limitations of EM guns before they reach a state of maturity. The EM gun will fire rounds at unequalled velocities, which will directly contribute to lethality. With-

out propellant case, EM rounds are much smaller, requiring less storage space, and therefore could be carried in greater quantities for extended firing operations. Because plasma containment and energy conversion efficiency tend to improve with bore diameter, it is possible that single, larger barrels with 90mm diameter will be used. The latter represents a major disadvantage in that the larger the diameter — the lower the ammunition complement, the heavier the gun, and the more difficult it is to reach higher velocities.

An interesting and promising 'spin-off' of EM technology is *EM Armor*.⁵ It is still highly classified and in its infancy, but some initial reports indicate that steel plates that get 'energized' upon impact could form a unidirectional strong magnetic field that is capable of deflecting and attenuating shape-charged warheads (increasing survivability up to a factor of 10). If this is feasible, there is another major application for electrical energy available on board the FCS to assist in its protection against anti-armor threats.

Note: All information contained in this article was derived from open-sources and the analysis of the authors.

Notes

¹Major Held, B. J., "Tomorrow's Smart Tank Munitions," *ARMOR*, March-April 1995, p. 21.

²Lt. Colonel (Ret.) Boschma, J.H., "Smart Top Attack Weapons," *ARMOR*, September-October 1996, p. 8.

³*Defense Daily*, 20 November 1996, p. 285.

⁴Pengelle, R., "A New Era In Tank Main Armament - The Options Multiply," *INTERNATIONAL DEFENSE REVIEW*, 11/1989, p. 1521.

⁵Metzgar, T. L., "From Dreamworld To Realworld: Electromagnetic Guns," November/December *A&DS*/ 19, p. 41.

Mr. Lawrence D. Bacon is the Director of Graphic Arts at WDH where, for the past 18 years, he has been responsible for creating numerous concepts for automatic ammunition handling, loading and storage systems.

Dr. Asher H. Sharoni is the Director of Engineering at WDH. He holds a Sc.D. in Mechanical Engineering from MIT and a M.Sc. & B.Sc. in Mechanical and Industrial Engineering from the Technion, Israel Institute of Technology. Dr. Sharoni is a former colonel in the Israeli Defense Forces in which he was involved in various major armored weapons developments. Dr. Sharoni has accumulated more than 30 years of experience in armor design and production.

⁶Editorial, "We Have a Winner!," *ARMOR*, July-August 1993, p. 6.

Western Design HOWDEN (WDH) is a small defense company in Irvine, California, which specializes in the design, development and production of ammunition and material handling systems for the U.S. and international military markets. WDH's track record includes a variety of air, land, and seaborne weapon systems which require automated feed, resupply, and optimized ammunition packaging. WDH has been involved among others in the Tank Test Bed, AC-130 U Gunship, AH-64 Apache, and Tank Compact Autoloader Programs.