

C3PO

1

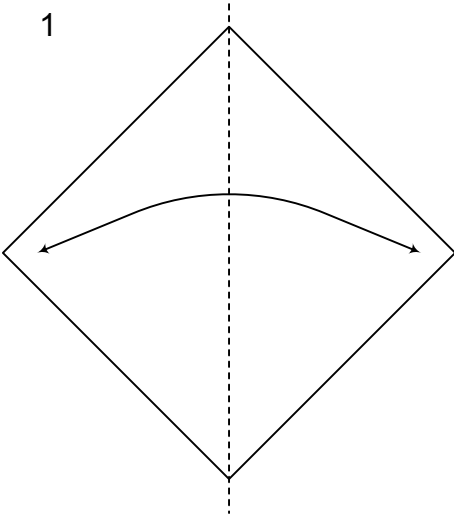

2

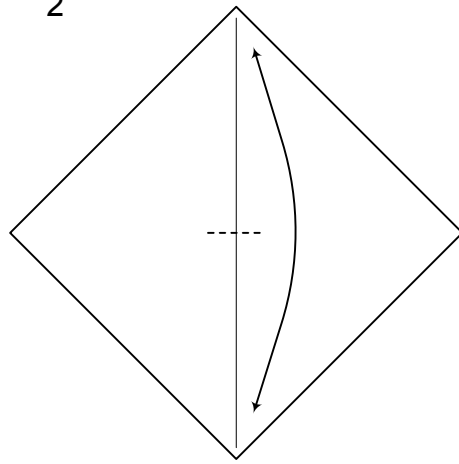

3

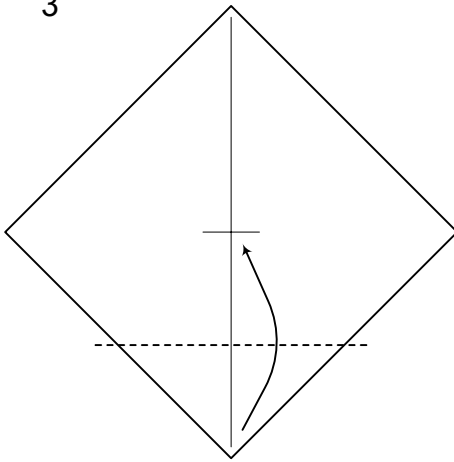

4

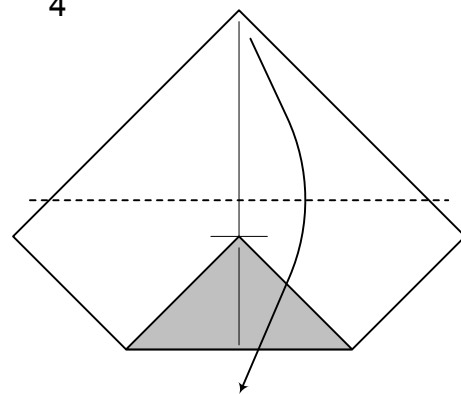

Valley fold, see step 5 for exact positioning

5

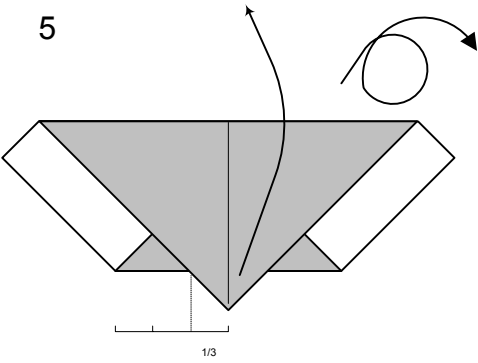

6

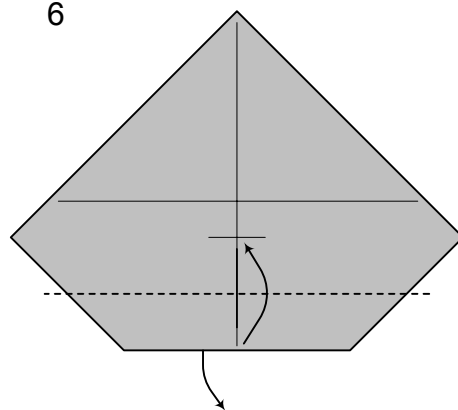

7

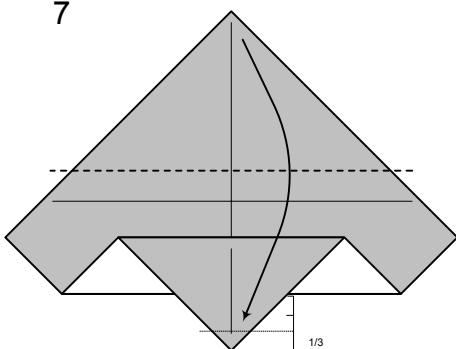

8

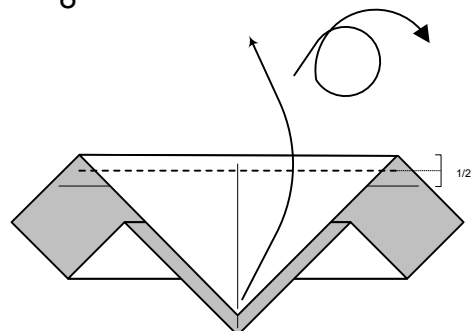

C3PO

9

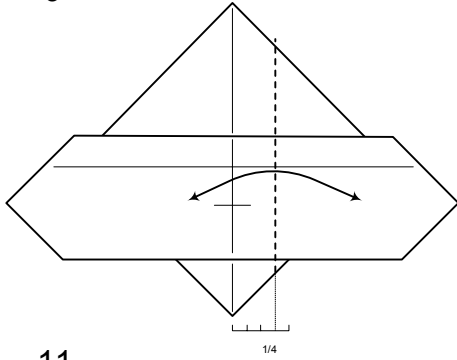

10

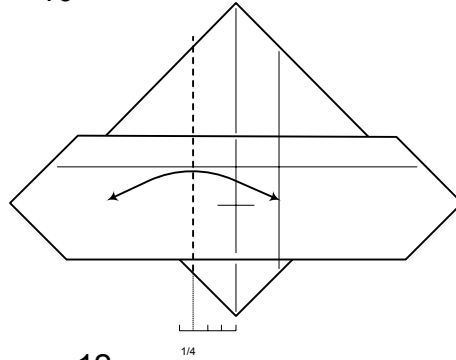

11

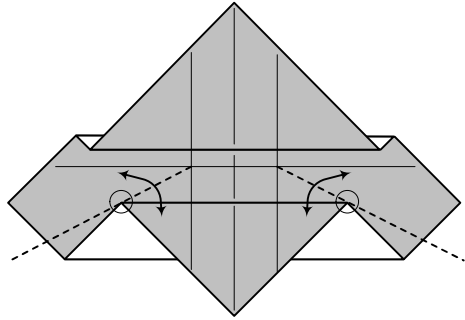

12

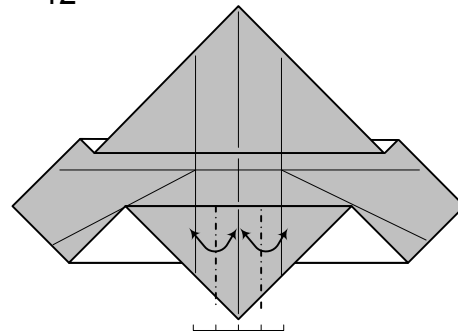

13

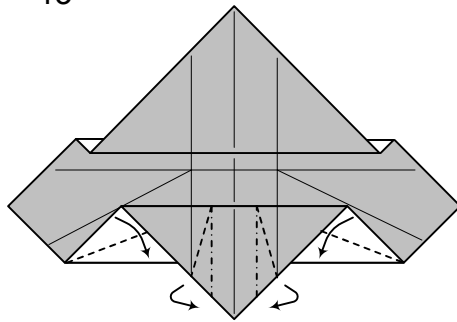

14

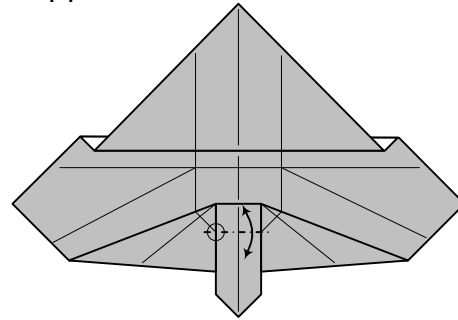

15

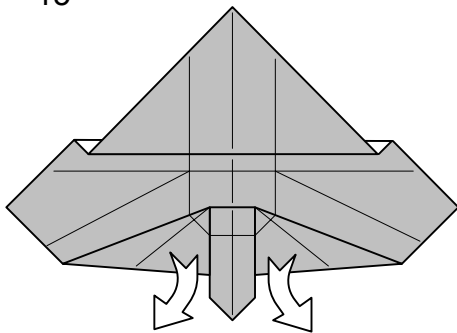

16

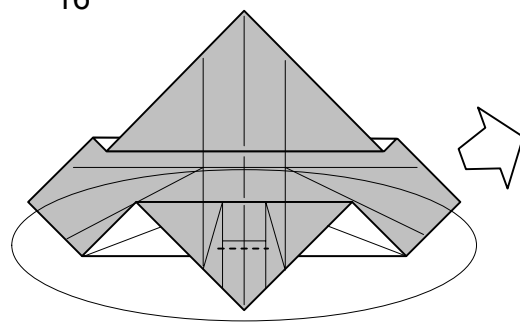

Unfold to step 13

Add another crease just below the crease from step 14

17

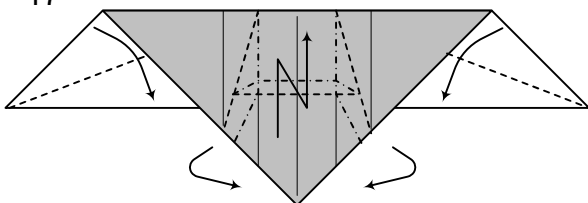

Refold step 12 incorporating a crimp to form the top of the mouth

18

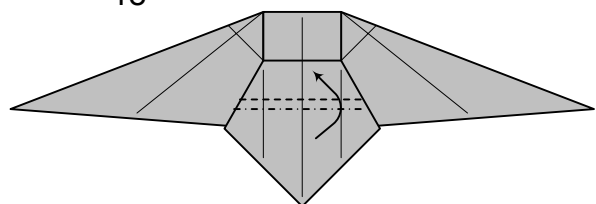

unfold again, then refold incorporating a crimp to form the bottom half of the mouth

C3PO

19

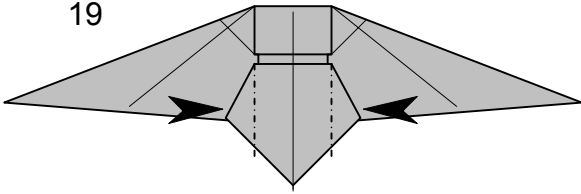

20

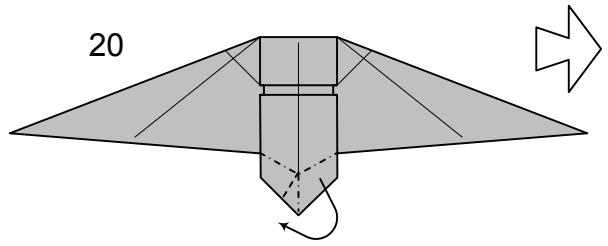

21

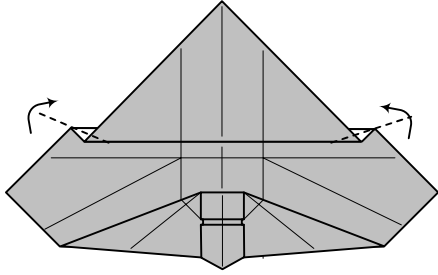

22

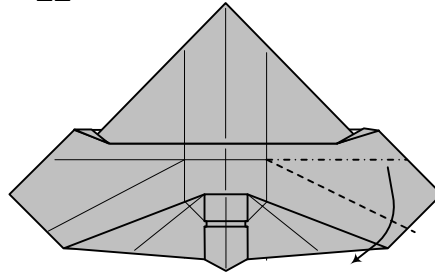

23

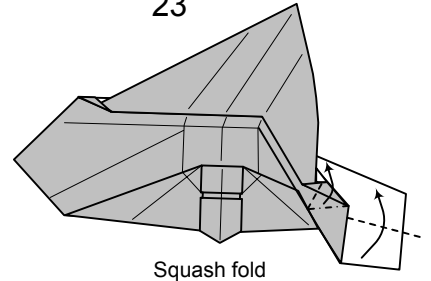

24

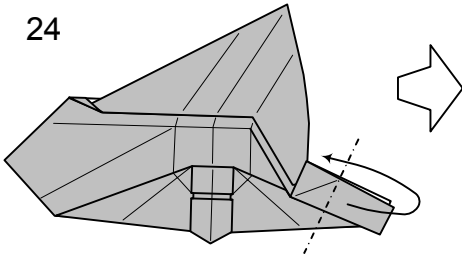

25

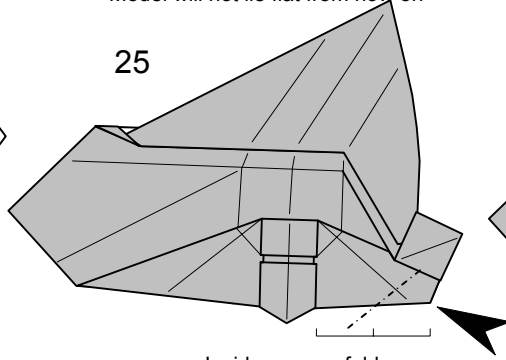

26

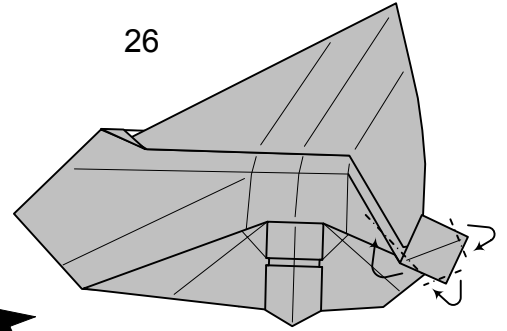

27

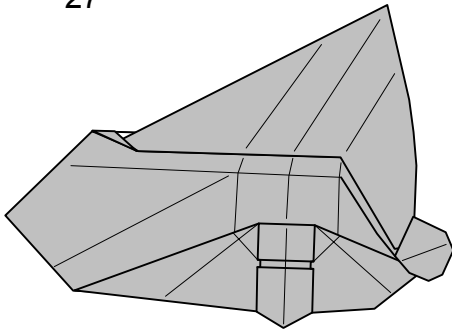

28

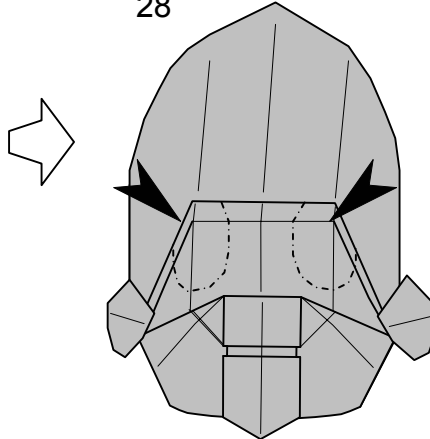

29

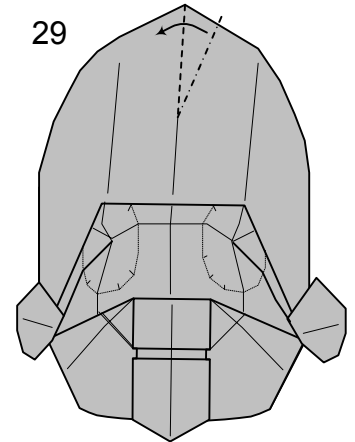

Repeat steps 22-26 on the left side

Sink the corners to form two ovals

Make the top of the head rounder

30

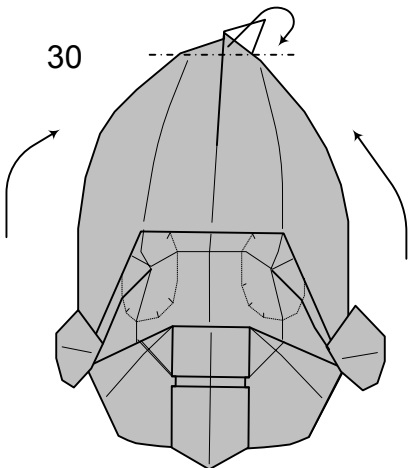

Lock the top of the head with a mountain fold, round the sides of the head

