



A380

AIRPLANE CHARACTERISTICS

AC

The content of this document is the property of Airbus.
It is supplied in confidence and commercial security on its contents must be maintained.
It must not be used for any purpose other than that for which it is supplied, nor may
information contained in it be disclosed to unauthorized persons.
It must not be reproduced in whole or in part without permission in writing from the owners of
the copyright. Requests for reproduction of any data in this document and the media authorized
for it must be addressed to Airbus.

© AIRBUS S.A.S. 2005. All rights reserved.

*AIRBUS S.A.S.
Customer Services
Technical Data Support and Services
31707 Blagnac Cedex
FRANCE*

LOCATIONS	CHG CODE	DESCRIPTIONS OF CHANGE
<u>CHAPTER 3</u> Section 3-1 Subject 3-1-0 General Information	R	PART EFFECTIVITY ADDED/REVISED/DELETED
Section 3-4 Subject 3-4-1 FIGURE Landing Field Length - Landing Field Length - A380-800F Models	R	
<u>CHAPTER 5</u> Section 5-4 Subject 5-4-2 Grounding Points	R	PART EFFECTIVITY ADDED/REVISED/DELETED
Subject 5-4-3 Hydraulic System	R	CHANGE OF YELLOW HYDRAULIC GROUND CONNECTOR ACCESS DOOR NUMBER. PART EFFECTIVITY ADDED/REVISED/DELETED
Subject 5-4-4 Electrical System - Pax	R	PART EFFECTIVITY ADDED/REVISED/DELETED
Electrical System - Freighter	R	PART EFFECTIVITY ADDED/REVISED/DELETED
Subject 5-4-5 Oxygen System	R	PART EFFECTIVITY ADDED/REVISED/DELETED
Subject 5-4-6 Fuel System	R	PART EFFECTIVITY ADDED/REVISED/DELETED
Subject 5-4-7		

LOCATIONS	CHG CODE	DESCRIPTIONS OF CHANGE
Pneumatic System Subject 5-4-8	R	PART EFFECTIVITY ADDED/REVISED/DELETED
Potable Water System - Pax	R	PART EFFECTIVITY ADDED/REVISED/DELETED
Potable Water System - Freighter	R	MINOR EDITORIAL CHANGE. PART EFFECTIVITY ADDED/REVISED/DELETED
Subject 5-4-9 Engine Oil Servicing	R	PART EFFECTIVITY ADDED/REVISED/DELETED
VFG Oil Servicing	R	PART EFFECTIVITY ADDED/REVISED/DELETED
Starter Oil Servicing	R	PART EFFECTIVITY ADDED/REVISED/DELETED
APU Oil Servicing	R	PART EFFECTIVITY ADDED/REVISED/DELETED
Subject 5-4-10 Vacuum Toilet System - Pax	R	PART EFFECTIVITY ADDED/REVISED/DELETED
Vacuum Toilet System - Freighter	R	PART EFFECTIVITY ADDED/REVISED/DELETED
Section 5-8 Subject 5-8-0 FIGURE Ground Towing Requirements - A380-800 Models	R	REVISED ILLUSTRATION.
<u>CHAPTER 6</u> Section 6-2 Subject 6-2-1 Airport and Community Noise Data	R	REVISED PARAGRAPH, ADDITION OF DESCRIPTION OF TEST CONDITION AND METEOROLOGICAL FOR GP7200 ENGINES.

LOCATIONS	CHG CODE	DESCRIPTIONS OF CHANGE
FIGURE Airport and Community Noise Data - TRENT 900 Engines	R	REVISED ILLUSTRATION, N1 PERCENTAGE DELETED.
FIGURE Airport and Community Noise Data - GP 7200 Engines	R	
<u>CHAPTER 7</u>		
Section 7-1		
Subject 7-1-0		
General Information	R	UPDATED DATA Minor correction in text description PART EFFECTIVITY ADDED/REVISED/DELETED
Section 7-2		
Subject 7-2-0		
Landing Gear Footprint - Pax	R	
FIGURE Landing Gear Footprint - MRW 512 000 kg - A380-800 Models	N	ILLUSTRATION ADDED
FIGURE Landing Gear Footprint - MRW 562 000 kg - A380-800 Models	N	ILLUSTRATION ADDED
FIGURE Landing Gear Footprint - MRW 571 000 kg - A380-800 Models	N	ILLUSTRATION ADDED
Landing Gear Footprint - Freighter	R	
FIGURE Landing Gear Footprint - MRW 592 000 kg - A380-800F Models	N	ILLUSTRATION ADDED
FIGURE Landing Gear Footprint - MRW 602 000 kg - A380-800F Models	N	ILLUSTRATION ADDED
Section 7-3		
Subject 7-3-0		
Maximum Pavement Loads - Pax	R	
FIGURE Maximum Pavement Loads - MRW 512 000 kg - A380-800 Models	N	ILLUSTRATION ADDED
FIGURE Maximum Pavement Loads - MRW 562 000 kg - A380-800 Models	R	

LOCATIONS	CHG CODE	DESCRIPTIONS OF CHANGE
FIGURE Maximum Pavement Loads - MRW 571 000 kg - A380-800 Models	R	
FIGURE Maximum Pavement Loads - Freighter - MRW 592 000 kg - A380-800F Models	R	
FIGURE Maximum Pavement Loads - MRW 602 000 kg- A380-800F Models	R	
Section 7-4		
Subject 7-4-0		
Landing Gear Loading on Pavement	R	MINOR LAYOUT UPDATES ADDED DATA WITH MRW 512000 KG FOR A380-800.
Subject 7-4-1		
Landing Gear Loading on Pavement - Pax	R	
FIGURE Landing Gear Loading on Pavement - MRW 512 000 kg - A380-800 Models	N	ILLUSTRATION ADDED
FIGURE Landing Gear Loading on Pavement - MRW 562 000 kg - A380-800 Models	N	ILLUSTRATION ADDED
FIGURE Landing Gear Loading on Pavement - MRW 571 000 kg - A380-800 Models	N	ILLUSTRATION ADDED
Landing Gear Loading on Pavement - Freighter	R	
FIGURE Landing Gear Loading on Pavement - MRW 592 000kg - A380-800F Models	N	ILLUSTRATION ADDED
FIGURE Landing Gear Loading on Pavement - MRW 602 000kg - A380-800F Models	N	ILLUSTRATION ADDED
Subject 7-4-2		
Wing Gear and Body Gear Loading on Pavement	R	MINOR LAYOUT UPDATES ADDED INFORMATION FOR MRW 512000 kg for A380-800
Subject 7-4-3		

LOCATIONS	CHG CODE	DESCRIPTIONS OF CHANGE
Wing Gear and Body Gear Loading on Pavement - Pax	R	
FIGURE Wing Gear and Body Gear Loads on Pavement - MRW 512 000 kg - A380-800 Models	N	ILLUSTRATION ADDED
FIGURE Wing Gear and Body Gear Loads on Pavement - MRW 562 000 kg - A380-800 Models	N	ILLUSTRATION ADDED
FIGURE Wing Gear and Body Gear Loads on Pavement - MRW 571 000 kg - A380-800 Models	N	ILLUSTRATION ADDED
Wing Gear and Body Gear Loading on Pavement - Freighter	R	
FIGURE Wing Gear and Body Gear Loads on Pavement - MRW 592 000 kg - A380-800F Models	N	ILLUSTRATION ADDED
FIGURE Wing Gear and Body Gear Loads on Pavement - MRW 602 000 kg - A380-800F Models	N	ILLUSTRATION ADDED
Section 7-5		
Subject 7-5-0		
Flexible Pavement Requirements - US Army Corps of Engineers Design Method	R	CHANGED MRW VALUE FROM 562000 KG TO 512000 KG AND FLEXIBLE PAVEMENT THICKNESS FROM 58 CM TO 54 CM.
Subject 7-5-1		
Flexible Pavement Requirements - US Army Corps of Engineers Design Method - Pax	R	
FIGURE Flexible Pavement Requirements - 4 Wheel Bogie - MRW 512 000 kg - A380-800 Models	N	ILLUSTRATION ADDED
FIGURE Flexible Pavement Requirements - 6 Wheel Bogie - MRW 512 000 kg - A380-800 Models	N	ILLUSTRATION ADDED
FIGURE Flexible Pavement Requirements - 4 Wheel Bogie - MRW 562 000 kg - A380-800 Models	N	ILLUSTRATION ADDED

LOCATIONS	CHG CODE	DESCRIPTIONS OF CHANGE
FIGURE Flexible Pavement Requirements – 6 Wheel Bogie - MRW 562 000 kg - A380-800 Models	R	
FIGURE Flexible Pavement Requirements – 4 Wheel Bogie - MRW 571 000 kg - A380-800 Models	N	ILLUSTRATION ADDED
FIGURE Flexible Pavement Requirements – 6 Wheel Bogie - MRW 571 000 kg - A380-800 Models	R	
Flexible Pavement Requirements - US Army Corps of Engineers Design Method - Freighter	R	
FIGURE Flexible Pavement Requirements – 4 Wheel Bogie - MRW 592 000 kg - A380-800F Models	N	ILLUSTRATION ADDED
FIGURE Flexible Pavement Requirements – 6 Wheel Bogie - MRW 592 000 kg - A380-800F Models	R	
FIGURE Flexible Pavement Requirements – 4 Wheel Bogie - MRW 602 000 kg - A380-800F Models	N	ILLUSTRATION ADDED
FIGURE Flexible Pavement Requirements – 6 Wheel Bogie - MRW 602 000 kg - A380-800F Models	R	
Section 7-6 Subject 7-6-0 General	R	UPDATED MRW AND LCN VALUES
Subject 7-6-1 Flexible Pavement Requirements - LCN Conversion - Pax	R	
FIGURE Flex Pavement Requirements LCN - 4 Wheel Bogie - MRW 512 000 kg - A380-800 Models	N	ILLUSTRATION ADDED
FIGURE Flex Pavement Requirements LCN - 6 Wheel Bogie - MRW 512 000 kg - A380-800 Models	N	ILLUSTRATION ADDED

LOCATIONS	CHG CODE	DESCRIPTIONS OF CHANGE
FIGURE Flex Pavement Requirements LCN - 4 Wheel Bogie - MRW 562 000 kg - A380-800 Models	R	
FIGURE Flex Pavement Requirements LCN - 6 Wheel Bogie - MRW 562 000 kg - A380-800 Models	R	
FIGURE Flex Pavement Requirements LCN - 4 Wheel Bogie - MRW 571 000 kg - A380-800 Models	R	
FIGURE Flex Pavement Requirements LCN - 6 Wheel Bogie - MRW 571 000 kg - A380-800 Models	R	
FIGURE Flex Pavement Requirements LCN - 4 Wheel Bogie - MRW 592 000 kg - A380-800F Models	R	
FIGURE Flex Pavement Requirements LCN - 6 Wheel Bogie - MRW 592 000 kg - A380-800F Models	R	
FIGURE Flex Pavement Requirements LCN - 4 Wheel Bogie - MRW 602 000 kg - A380-800F Models	R	
FIGURE Flex Pavement Requirements LCN - 6 Wheel Bogie - MRW 602 000 kg - A380-800F Models	R	
Section 7-7		
Subject 7-7-0		
Rigid Pavement Requirements - Portland Cement Association Design Method	R	UPDATED VALUES
Subject 7-7-1		
Rigid Pavement Requirements - Portland Cement Association Design Method - Pax	R	
FIGURE Rigid Pavement Requirements - 4 Wheel Bogie - MRW 512 000 kg - A380-800 Models	N	ILLUSTRATION ADDED
FIGURE Rigid Pavement Requirements - 6 Wheel Bogie - MRW 512 000 kg - A380-800 Models	N	ILLUSTRATION ADDED

LOCATIONS	CHG CODE	DESCRIPTIONS OF CHANGE
FIGURE Rigid Pavement Requirements - 4 Wheel Bogie - MRW 562 000 kg - A380-800 Models	N	ILLUSTRATION ADDED
FIGURE Rigid Pavement Requirements - 6 Wheel Bogie - MRW 562 000 kg - A380-800 Models	R	
FIGURE Rigid Pavement Requirements - 4 Wheel Bogie - MRW 571 000 kg - A380-800 Models	N	ILLUSTRATION ADDED
FIGURE Rigid Pavement Requirements - 6 Wheel Bogie - MRW 571 000 kg - A380-800 Models	R	
Rigid Pavement Requirements - Portland Cement Association Design Method - Freighter	R	
FIGURE Rigid Pavement Requirements - 4 Wheel Bogie - MRW 592 000 kg - A380-800F Models	N	ILLUSTRATION ADDED
FIGURE Rigid Pavement Requirements - 6 Wheel Bogie - MRW 592 000 kg - A380-800F Models	R	
FIGURE Rigid Pavement Requirements - 4 Wheel Bogie - MRW 602 000 kg - A380-800F Models	N	ILLUSTRATION ADDED
FIGURE Rigid Pavement Requirements - 6 Wheel Bogie - MRW 602 000 kg - A380-800F Models	R	
Section 7-8		
Subject 7-8-0 Rigid Pavement Requirements - LCN Conversion	R	
Subject 7-8-2 Rigid Pavement Requirements - LCN Conversion - Pax	R	
FIGURE Rigid Pavement Requirements LCN - 4 Wheel Bogie - MRW 512 000 kg - A380-800 Models	N	ILLUSTRATION ADDED

LOCATIONS	CHG CODE	DESCRIPTIONS OF CHANGE
FIGURE Rigid Pavement Requirements LCN - 6 Wheel Bogie - MRW 512 000 kg - A380-800 Models	N	ILLUSTRATION ADDED
FIGURE Rigid Pavement Requirements LCN - 4 Wheel Bogie - MRW 562 000 kg - A380-800 Models	R	
FIGURE Rigid Pavement Requirements LCN - 6 Wheel Bogie - MRW 562 000 kg - A380-800 Models	R	
FIGURE Rigid Pavement Requirements LCN - 4 Wheel Bogie - MRW 571 000 kg - A380-800 Models	R	
FIGURE Rigid Pavement Requirements LCN - 6 Wheel Bogie - MRW 571 000 kg - A380-800 Models	R	
FIGURE Rigid Pavement Requirements LCN - 4 Wheel Bogie - MRW 592 000 kg - A380-800F Models	R	
FIGURE Rigid Pavement Requirements LCN - 6 Wheel Bogie - MRW 592 000 kg - A380-800F Models	R	
FIGURE Rigid Pavement Requirements LCN - 4 Wheel Bogie - MRW 602 000 kg - A380-800F Models	R	
FIGURE Rigid Pavement Requirements LCN - 6 Wheel Bogie - MRW 602 000 kg - A380-800F Models	R	
Subject 7-8-3 Radius of Relative Stiffness (Other values of E and μ)	R	DESCRIPTION TITLE UPDATED
Subject 7-8-4 Radius of Relative Stiffness (Other values of E and μ)	R	DESCRIPTION TITLE UPDATED
Section 7-9 Subject 7-9-0 ACN/PCN Reporting System	R	

LOCATIONS	CHG CODE	DESCRIPTIONS OF CHANGE
Subject 7-9-1		
Aircraft Classification Number - Flexible Pavement - Pax	R	
FIGURE Aircraft Classification Number - Flexible Pavement - MRW 512 000 kg - A380-800 Models	N	ILLUSTRATION ADDED
FIGURE Aircraft Classification Number - Flexible Pavement - MRW 562 000 kg - A380-800 Models	N	ILLUSTRATION ADDED
FIGURE Aircraft Classification Number - Flexible Pavement - MRW 571 000 kg - A380-800 Models	N	ILLUSTRATION ADDED
Aircraft Classification Number - Flexible Pavement - Freighter	R	
FIGURE Aircraft Classification Number - Flexible Pavement - MRW 592 000 kg - A380-800F Models	N	ILLUSTRATION ADDED
FIGURE Aircraft Classification Number - Flexible Pavement - MRW 602 000 kg - A380-800F Models	N	ILLUSTRATION ADDED
Subject 7-9-2		
Aircraft Classification Number - Rigid Pavement - Pax	R	
FIGURE Aircraft Classification Number - Rigid Pavement - MRW 512 000 kg - A380-800 Models	N	ILLUSTRATION ADDED
FIGURE Aircraft Classification Number - Rigid Pavement - MRW 562 000 kg - A380-800 Models	N	ILLUSTRATION ADDED
FIGURE Aircraft Classification Number - Rigid Pavement - MRW 571 000 kg - A380-800 Models	N	ILLUSTRATION ADDED
Aircraft Classification Number - Rigid Pavement - Freighter	R	
FIGURE Aircraft Classification Number - Rigid Pavement - MRW 592 000 kg - A380-800F Models	N	ILLUSTRATION ADDED

LOCATIONS	CHG CODE	DESCRIPTIONS OF CHANGE
FIGURE Aircraft Classification Number - Rigid Pavement - MRW 602 000 kg - A380-800F Models	N	ILLUSTRATION ADDED

LIST OF EFFECTIVE CONTENT

Revision No. 7 - Nov 01/08

CONTENT	CHG CODE	LAST REVISION DATE
<u>CHAPTER 1</u>		
Subject 1-1-0		
Purpose		Jun 01/07
Subject 1-2-0		
Introduction	R	Nov 01/08
Subject 1-2-1		
Glossary	R	Nov 01/08
<u>CHAPTER 2</u>		
Subject 2-1-0		
General Airplane Characteristics		Jun 01/07
Subject 2-1-1		
General Airplane Characteristics data	R	Nov 01/08
Subject 2-2-0		
General Airplane Dimensions Data		Jun 01/07
FIGURE General Airplane Dimensions - General Airplane Dimensions	R	Nov 01/08
Subject 2-3-0		
Ground Clearances - Pax		Jun 01/07
FIGURE Ground Clearances - A380-800 Models		Jun 01/07
Ground Clearances - Freighter		Jun 01/07
FIGURE Ground clearances - A380-800F Models		Jun 01/07
Subject 2-4-0		
Interior Arrangement - Plan View		Jun 01/07
Subject 2-4-1		
Standard Configuration - Pax		Jun 01/07
FIGURE Interior Arrangements - Plan View - Standard Configuration		Jun 01/07
- Upper Deck		

CONTENT	CHG CODE	LAST REVISION DATE
FIGURE Interior Arrangements - Plan View - Standard Configuration - Main Deck		Jun 01/07
Standard Configuration - Freighter		Jun 01/07
FIGURE Interior Arrangements - Plan View - Standard Configuration		Jun 01/07
Subject 2-5-0		
Interior Arrangements - Cross Section		Jun 01/07
Subject 2-5-1		
Typical Configuration - Pax		Jun 01/07
FIGURE Interior Arrangements - Cross-section - Typical Configuration - Upper Deck		Jun 01/07
FIGURE Interior Arrangements - Cross-section - Typical Configuration - Main Deck		Jun 01/07
Typical Configuration - Freighter		Jun 01/07
FIGURE Interior Arrangements - Cross-section - Typical Configuration - A380- 800F Models All Decks	R	Nov 01/08
Subject 2-6-0		
Cargo Compartments		Jun 01/07
Subject 2-6-1		
Location and Dimensions - Pax		Jun 01/07
FIGURE Cargo Compartments - Location and Dimensions		Jun 01/07
Location and Dimensions - Freighter		Jun 01/07
FIGURE Cargo Compartments - Location and Dimensions (Sheet 1)		Jun 01/07
FIGURE Cargo Compartments - Location and Dimensions (Sheet 2)		Jun 01/07
Subject 2-6-2		
Loading Combinations - Pax		Jun 01/07
FIGURE Cargo Compartments - Loading Combinations		Jun 01/07
Loading Combinations - Freighter		Jun 01/07
FIGURE Cargo Compartments - Loading Combinations (Sheet 1)		Jun 01/07
FIGURE Cargo Compartments - Loading Combinations (Sheet 2)		Jun 01/07
Subject 2-7-0		

CONTENT	CHG CODE	LAST REVISION DATE
Door Clearances - Pax		Jun 01/07
FIGURE Door Clearances - Door Location (Sheet 1) - A380-800 Models		Jun 01/07
FIGURE Door Clearances - Door Location (Sheet 2) - A380-800 Models		Jun 01/07
Door Clearances - Freighter		Jun 01/07
FIGURE Door Clearances - Door Location (Sheet 1) - A380-800F Models		Jun 01/07
FIGURE Door Clearances - Door Location (Sheet 2) - A380-800F Models		Jun 01/07
Subject 2-7-1		
Forward Doors		Jun 01/07
FIGURE Door Clearances - Forward Doors		Jun 01/07
Subject 2-7-2		
Main and Upper Deck Doors - Pax		Jun 01/07
FIGURE Door Clearances - Main and Upper Deck Doors - A380-800 Models		Jun 01/07
Upper Deck Door - Freighter		Jun 01/07
FIGURE Door Clearances - Upper Deck Door - A380-800F Models		Jun 01/07
Subject 2-7-3		
Aft Doors - Pax		Jun 01/07
FIGURE Door Clearances - Aft Doors - A380-800 Models		Jun 01/07
Aft Doors - Freighter		Jun 01/07
FIGURE Door Clearances - Aft Doors - A380-800F Models		Jun 01/07
Subject 2-7-4		
Aft Cargo Compartment Doors - Pax		Jun 01/07
FIGURE Door Clearances - Aft Cargo Compartment Doors - A380-800 Models		Jun 01/07
Aft Cargo Compartment Doors - Freighter		Jun 01/07
FIGURE Door Clearances - Main Deck Cargo Door - A380-800F Models		Jun 01/07

CONTENT	CHG CODE	LAST REVISION DATE
FIGURE Door Clearances - Lower Deck Aft Cargo Doors - A380-800F Models Subject 2-7-5		Jun 01/07
Forward Cargo Compartment Doors - Pax		Jun 01/07
FIGURE Door Clearances - Forward Cargo Compartment Doors - A380-800 Models		Jun 01/07
Forward Cargo Compartment Doors - Freighter		Jun 01/07
FIGURE Door Clearances - Upper Deck Cargo Door - A380-800F Models		Jun 01/07
FIGURE Door Clearances - Lower Deck Forward Cargo Door - A380-800F Models Subject 2-7-6		Jun 01/07
Nose Landing Gear Doors		Jun 01/07
FIGURE Door Clearances - Forward Nose Landing Gear Doors		Jun 01/07
FIGURE Door Clearances - Aft Nose Landing Gear Doors Subject 2-7-7		Jun 01/07
Wing Landing Gear Doors		Jun 01/07
FIGURE Door Clearances - Wing Landing Gear Doors Subject 2-7-8		Jun 01/07
Body Landing Gear Doors		Jun 01/07
FIGURE Door Clearances - Body Landing Gear Doors (Sheet 1)		Jun 01/07
FIGURE Door Clearances - Body Landing Gear Doors (Sheet 2) Subject 2-7-9		Jun 01/07
APU Doors		Jun 01/07
FIGURE Door Clearances - APU Doors CHAPTER 3		Jun 01/07
Subject 3-1-0		
General Information	R	Nov 01/08
Subject 3-2-0		
Payload /Range		Jun 01/07

CONTENT	CHG CODE	LAST REVISION DATE
Subject 3-2-1 Payload/Range - Pax FIGURE Payload/Range - ISA Conditions - TRENT 900 Engines FIGURE Payload/Range - ISA Conditions - GP 7200 Engines Payload/Range - Freighter FIGURE Payload/Range - ISA Conditions - TRENT 900 Engines FIGURE Payload/Range - ISA Conditions - GP 7200 Engines		Jun 01/07 Jun 01/07 Jun 01/07 Jun 01/07 Jun 01/07 Jun 01/07
Subject 3-3-0 Take Off Weight Limitation		Jun 01/07
Subject 3-3-1 Take Off Weight Limitation - Pax FIGURE Take-Off Weight Limitation - ISA Conditions - TRENT 900 Engines FIGURE Take-Off Weight Limitation - ISA Conditions - GP 7200 Engines Take-Off Weight Limitation - Freighter FIGURE Take-Off Weight Limitation - ISA Conditions - TRENT 900 Engines FIGURE Take-Off Weight Limitation - ISA Conditions - GP 7200 Engines		Jun 01/07 Jun 01/07 Jun 01/07 Jun 01/07 Jun 01/07 Jun 01/07
Subject 3-3-2 ISA + 15 °C (59 °F) - Pax FIGURE Take-Off Weight Limitation - ISA + 15 °C (59 °F) - TRENT 900 Engines FIGURE Take-Off Weight Limitation - ISA + 15 °C (59 °F) - GP 7200 Engines ISA + 15 °C (59 °F) - Freighter FIGURE Take-Off Weight Limitation - ISA + 15 °C (59 °F) - TRENT 900 Engines FIGURE Take-Off Weight Limitation - ISA + 15 °C (59 °F) - GP 7200 Engines		Jun 01/07 Jun 01/07 Jun 01/07 Jun 01/07 Jun 01/07 Jun 01/07

CONTENT	CHG CODE	LAST REVISION DATE
Subject 3-4-0 Landing Field Length		Jun 01/07
Subject 3-4-1 Landing Field Length - Pax		Jun 01/07
FIGURE Landing Field Length - Landing Field Length - A380-800 Models		Jun 01/07
Landing Field Length - Freighter		Jun 01/07
FIGURE Landing Field Length - Landing Field Length - A380-800F Models	R	Nov 01/08
Subject 3-5-0 Final Approach Speed		Jun 01/07
Subject 3-5-1 Final Approach Speed - Pax		Jun 01/07
FIGURE Final Approach Speed (CG=29%) - A380-800 Models		Jun 01/07
Final Approach Speed - Freighter		Jun 01/07
FIGURE Final Approach Speed (CG=29%) - A380-800F Models		Jun 01/07
<u>CHAPTER 4</u>		
Subject 4-1-0 General		Jun 01/07
Subject 4-2-0 Turning Radii		Jun 01/07
FIGURE Turning Radii - Turning Radii (Sheet 1)		Jun 01/07
FIGURE Turning Radii - Turning Radii (Sheet 2)		Jun 01/07
Subject 4-3-0 Minimum Turning Radii		Jun 01/07
FIGURE Minimum Turning Radii - Minimum Turning Radii		Jun 01/07
Subject 4-4-0 Visibility from Cockpit in Static Position		Jun 01/07
FIGURE Visibility from Cockpit in Static Position - Visibility from Cockpit in Static Position		Jun 01/07

CONTENT	CHG CODE	LAST REVISION DATE
Subject 4-5-0 Runway and Taxiway Turn Paths		Jun 01/07
Subject 4-5-1		
135° Turn - Runway to Taxiway		Jun 01/07
FIGURE 135° Turn – Runway to Taxiway - 135° Turn – Runway to Taxiway (Sheet 1)		Jun 01/07
FIGURE 135° Turn – Runway to Taxiway - 135° Turn – Runway to Taxiway (Sheet 2)		Jun 01/07
Subject 4-5-2		
90° Turn - Runway to Taxiway		Jun 01/07
FIGURE 90° Turn – Runway to Taxiway - 90° Turn – Runway to Taxiway (Sheet 1)		Jun 01/07
FIGURE 90° Turn – Runway to Taxiway - 90° Turn – Runway to Taxiway (Sheet 2)		Jun 01/07
Subject 4-5-3		
180° Turn on a Runway		Jun 01/07
FIGURE 180° Turn on a Runway - 180° Turn on a Runway		Jun 01/07
Subject 4-5-4		
90° Turn - Taxiway to Taxiway		Jun 01/07
FIGURE 90° Turn – Taxiway to Taxiway - 90° Turn – Taxiway to Taxiway (Sheet 1)		Jun 01/07
FIGURE 90° Turn – Taxiway to Taxiway - 90° Turn – Taxiway to Taxiway (Sheet 2)		Jun 01/07
Subject 4-5-5		
135° Turn - Taxiway to Taxiway		Jun 01/07
FIGURE 135° Turn – Taxiway to Taxiway - 135° Turn – Taxiway to Taxiway (Sheet 1)		Jun 01/07
FIGURE 135° Turn – Taxiway to Taxiway - 135° Turn – Taxiway to Taxiway (Sheet 2)		Jun 01/07
Subject 4-6-0 Runway Holding Bay (Apron)		Jun 01/07

CONTENT	CHG CODE	LAST REVISION DATE
FIGURE Runway Holding Bay (Apron) - Runway Holding Bay (Apron)		Jun 01/07
Subject 4-7-0		
Airplane Parking		Jun 01/07
FIGURE Airplane Parking - Steering Geometry		Jun 01/07
FIGURE Airplane Parking - Minimum Parking Space Requirements		Jun 01/07
Subject 4-8-0		
General		Jun 01/07
FIGURE Airplane Mooring - Airplane Mooring		Jun 01/07
<u>CHAPTER 5</u>		
Subject 5-1-0		
Airplane Servicing Arrangements		Jun 01/07
Subject 5-1-1		
Typical Ramp Layout - Two Bridges - Standard Servicing		Jun 01/07
FIGURE Baseline Ramp Layout – Two Bridges - Servicing Via Main and Upper Decks		Jun 01/07
Subject 5-1-2		
Typical Ramp Layout - Two Bridges - Servicing Via Main Deck		Jan 31/08
FIGURE Typical Ramp Layout – Two Bridges - Servicing Via Main Deck		Jun 01/07
Subject 5-1-3		
Opportunities of Direct Upper Deck Access for Airport and Airlines		Jan 31/08
FIGURE Opportunities of Direct Upper Deck Access - for Airport and Airlines		Jun 01/07
Subject 5-1-4		
Baseline Ramp Layout		Jun 01/07
FIGURE Baseline Ramp Layout - Baseline Ramp Layout		Jun 01/07
Subject 5-2-0		
Terminal Operation - Passenger Aircraft		Jun 01/07
Subject 5-2-1		

CONTENT	CHG CODE	LAST REVISION DATE
Typical Turn-Round Time - Two Bridges - Standard Servicing Via Main Deck and Upper Decks		Jun 01/07
FIGURE Typical Turn-Round Time – Two Bridges - Servicing Via Main and Upper Decks		Jun 01/07
Subject 5-2-2		
Typical Turn-Round Time - Two Bridges - Servicing Via Main Deck		Jun 01/07
FIGURE Typical Turn-Round Time – Two Bridges - Servicing Via Main Deck		Jun 01/07
Subject 5-3-0		
Terminal Operation - Cargo Aircraft		Jun 01/07
Subject 5-3-1		
Typical Turn-Round Time		Jun 01/07
Subject 5-4-0		
Ground Service Connections		Jan 31/08
Subject 5-4-1		
Ground Service Connections Layout - Pax		Jun 01/07
FIGURE Ground Service Connections - Ground Service Connections Layout - A380-800 Models		Jun 01/07
Ground Service Connections Layout - Freighter		Jun 01/07
FIGURE Ground Service Connections - Ground Service Connections Layout - A380-800F Models		Jun 01/07
Subject 5-4-2		
Grounding Points	R	Nov 01/08
FIGURE Ground Points NLG - Ground Points NLG		Jun 01/07
FIGURE Ground Point WLG - Ground Point WLG		Jun 01/07
FIGURE Ground Points BLG - Ground Points BLG		Jun 01/07
Subject 5-4-3		
Hydraulic System	R	Nov 01/08
FIGURE Ground Service Connections - Hydraulical Reservoir Servicing Panel		Jun 01/07
FIGURE Ground Service Connections - Hydraulic Ground Connections		Jun 01/07



AIRPLANE CHARACTERISTICS

CONTENT	CHG CODE	LAST REVISION DATE
Subject 5-4-4		
Electrical System - Pax	R	Nov 01/08
FIGURE Ground Service Connections - Electrical Service Panel - A380-800 Models		Jun 01/07
Electrical System - Freighter	R	Nov 01/08
FIGURE Ground Service Connections - Electrical Service Panel - A380-800F Models		Jun 01/07
Subject 5-4-5		
Oxygen System	R	Nov 01/08
FIGURE Ground Service Connections - Oxygen System		Jun 01/07
Subject 5-4-6		
Fuel System	R	Nov 01/08
FIGURE Ground Service Connections - Refuel/Defuel Control Panel		Jun 01/07
FIGURE Ground Service Connections - Pressure Refuel Connections		Jun 01/07
Subject 5-4-7		
Pneumatic System	R	Nov 01/08
FIGURE Ground Service Connections - Low Pressure Preconditioned Air		Jun 01/07
FIGURE Ground Service Connections - High Pressure Preconditioned Air		Jun 01/07
Subject 5-4-8		
Potable Water System - Pax	R	Nov 01/08
FIGURE Ground Service Connections - Potable Water Ground Service Panel - A380-800 Models		Jun 01/07
FIGURE Ground Service Connections - Potable Water Drain Panel - A380-800 Models		Jun 01/07
Potable Water System - Freighter	R	Nov 01/08
FIGURE Ground Service Connections - Potable Water Ground Service Panel - A380-800F Models		Jun 01/07
Subject 5-4-9		
Engine Oil Servicing	R	Nov 01/08

CONTENT	CHG CODE	LAST REVISION DATE
FIGURE Ground Service Connections - Engine Oil Servicing - TRENT 900 Engines		Jun 01/07
FIGURE Ground Service Connections - Engine Oil Servicing - GP 7200 Engines		Jun 01/07
VFG Oil Servicing	R	Nov 01/08
FIGURE Ground Service Connections - VFG Oil Servicing - TRENT 900 Engines		Jun 01/07
FIGURE Ground Service Connections - VFG Oil Servicing - GP 7200 Engines		Jun 01/07
Starter Oil Servicing	R	Nov 01/08
FIGURE Ground Service Connections - Starter Oil Servicing - TRENT 900 Engines		Jun 01/07
FIGURE Ground Service Connections - Starter Oil Servicing - GP 7200 Engines		Jun 01/07
APU Oil Servicing	R	Nov 01/08
FIGURE Ground Service Connections - APU Oil Servicing		Jun 01/07
Subject 5-4-10		
Vacuum Toilet System - Pax	R	Nov 01/08
FIGURE Ground Service Connections - Vacuum Toilet System - A380-800 Models		Jun 01/07
Vacuum Toilet System - Freighter	R	Nov 01/08
FIGURE Ground Service Connections - Vacuum Toilet System - A380-800F Models		Jun 01/07
Subject 5-5-0		
Engine Starting Pneumatic Requirements		Jun 01/07
Subject 5-5-1		
Outside Air Temperature = -40 °C (-40 °F)		Jun 01/07
FIGURE Engine Starting Pneumatic Requirements (two high pressure ground carts) - Ambient Temperature -40 °C (-40 °F), sea level - TRENT 900 Engines		Jun 01/07
FIGURE Engine Starting Pneumatic Requirements (two high pressure ground carts) - Ambient Temperature -40 °C (-40 °F), sea level - GP 7200 Engines		Jun 01/07

CONTENT	CHG CODE	LAST REVISION DATE
FIGURE Engine Starting Pneumatic Requirements (three high pressure ground carts) - Ambient Temperature -40 °C (-40 °F), Sea Level - TRENT 900 Engines		Jun 01/07
FIGURE Engine Starting Pneumatic Requirements (three high pressure ground carts) - Ambient Temperature -40 °C (-40 °F), Sea Level - GP 7200 Engines		Jun 01/07
Subject 5-5-2 Outside Air Temperature = 15 °C (59 °F)		Jun 01/07
FIGURE Engine Starting Pneumatic Requirements (two high pressure ground carts) - Ambient Temperature +15 °C (+59 °F), Sea Level - TRENT 900 Engines		Jun 01/07
FIGURE Engine Starting Pneumatic Requirements (two high pressure ground carts) - Ambient Temperature +15 °C (+59 °F), Sea Level - GP 7200 Engines		Jun 01/07
FIGURE Engine Starting Pneumatic Requirements (two high pressure ground carts) - Ambient Temperature +15 °C (+59 °F), 5000FT Level - TRENT 900 Engines		Jun 01/07
FIGURE Engine Starting Pneumatic Requirements (two high pressure ground carts) - Ambient Temperature +15 °C (+59 °F), 5000FT Level - GP 7200 Engines		Jun 01/07
FIGURE Engine Starting Pneumatic Requirements (three high pressure ground carts) - Ambient Temperature +15 °C (+59 °F), Sea Level - TRENT 900 Engines		Jun 01/07
FIGURE Engine Starting Pneumatic Requirements (three high pressure ground carts) - Ambient Temperature +15 °C (+59 °F), Sea Level - GP 7200 Engines		Jun 01/07
FIGURE Engine Starting Pneumatic Requirements (three high pressure ground carts) - Ambient Temperature +15 °C (+59 °F), 5000FT Level - TRENT 900 Engines		Jun 01/07
FIGURE Engine Starting Pneumatic Requirements (three high pressure ground carts) - Ambient Temperature +15 °C (+59 °F), 5000FT Level - GP 7200 Engines		Jun 01/07
Subject 5-5-3 Outside Air Temperature = 50 °C (122 °F)		Jun 01/07

CONTENT	CHG CODE	LAST REVISION DATE
FIGURE Engine Starting Pneumatic Requirements (two high pressure ground carts) - Ambient Temperature +55 ° C (+131 ° F), Sea Level - TRENT 900 Engines		Jun 01/07
FIGURE Engine Starting Pneumatic Requirements (two high pressure ground carts) - Ambient Temperature +55 ° C (+131 ° F), Sea Level - GP 7200 Engines		Jun 01/07
FIGURE Engine Starting Pneumatic Requirements (three high pressure ground carts) - Ambient Temperature +55 ° C (+131 ° F), Sea Level - TRENT 900 Engines		Jun 01/07
FIGURE Engine Starting Pneumatic Requirements (three high pressure ground carts) - Ambient Temperature +55 ° C (+131 ° F), Sea Level - GP 7200 Engines		Jun 01/07
Subject 5-6-0 Ground Pneumatic Power Requirements		Jun 01/07
Subject 5-6-1 Heating		Jun 01/07
FIGURE Ground Pneumatic Power Requirements Heating - Ground Pneumatic Power Requirements Heating - A380-800 Models		Jun 01/07
FIGURE Ground Pneumatic Power Requirements Heating - Ground Pneumatic Power Requirements Heating - A380-800F Models		Jun 01/07
Subject 5-6-2 Cooling		Jun 01/07
FIGURE Ground Pneumatic Power Requirements Cooling - Ground Pneumatic Power Requirements Cooling - A380-800 Models		Jun 01/07
FIGURE Ground Pneumatic Power Requirements Cooling - Ground Pneumatic Power Requirements Cooling - A380-800F Models		Jun 01/07
Subject 5-7-0 Preconditioned Airflow Requirements		Jun 01/07
FIGURE Preconditioned Airflow Requirements - Preconditioned Airflow Requirements - A380-800 Models		Jun 01/07
FIGURE Preconditioned Airflow Requirements - Preconditioned Airflow Requirements - A380-800F Models		Jun 01/07
Subject 5-8-0		

CONTENT	CHG CODE	LAST REVISION DATE
Ground Towing Requirements FIGURE Ground Towing Requirements - A380-800 Models	R	Jan 31/08 Nov 01/08
<u>CHAPTER 6</u>		
Subject 6-1-0		
Engine Exhaust Velocities and Temperatures		Jun 01/07
Subject 6-1-1		
Engine Exhaust Velocities - Ground Idle Power		Jun 01/07
FIGURE Engine Exhaust Velocities - Ground Idle Power - TRENT 900 Engines		Jun 01/07
FIGURE Engine Exhaust Velocities - Ground Idle Power - GP 7200 Engines		Jun 01/07
Subject 6-1-2		
Engine Exhaust Temperatures - Ground Idle Power		Jun 01/07
FIGURE Engine Exhaust Temperatures - Ground Idle Power - TRENT 900 Engines		Jun 01/07
FIGURE Engine Exhaust Temperatures - Ground Idle Power - GP 7200 Engines		Jun 01/07
Subject 6-1-3		
Engine Exhaust Velocities - Breakaway Power		Jun 01/07
FIGURE Engine Exhaust Velocities - Breakaway Power - TRENT 900 Engines		Jun 01/07
FIGURE Engine Exhaust Velocities - Breakaway Power - GP 7200 Engines		Jun 01/07
Subject 6-1-4		
Engine Exhaust Temperatures - Breakaway Power		Jun 01/07
FIGURE Engine Exhaust Temperatures - Breakaway Power - TRENT 900 Engines		Jun 01/07
FIGURE Engine Exhaust Temperatures - Breakaway Power - GP 7200 Engines		Jun 01/07
Subject 6-1-5		
Engine Exhaust Velocities - Max Take-off Power		Jun 01/07

CONTENT	CHG CODE	LAST REVISION DATE
FIGURE Engine Exhaust Velocities - Max. Take-Off Power - TRENT 900 Engines		Jun 01/07
FIGURE Engine Exhaust Velocities - Max. Take-Off Power - GP 7200 Engines		Jun 01/07
Subject 6-1-6		
Engine Exhaust Temperatures - Max Take-off Power		Jun 01/07
FIGURE Engine Exhaust Temperatures - Max Take-Off Power - TRENT 900 Engines		Jun 01/07
FIGURE Engine Exhaust Temperatures - Max Take-Off Power - GP 7200 Engines		Jun 01/07
Subject 6-2-0		
Airport and Community Noise Data		Jun 01/07
Subject 6-2-1		
Airport and Community Noise Data	R	Nov 01/08
FIGURE Airport and Community Noise Data - TRENT 900 Engines	R	Nov 01/08
FIGURE Airport and Community Noise Data - GP 7200 Engines	R	Nov 01/08
Subject 6-3-0		
Danger Areas of the Engines		Jun 01/07
Subject 6-3-1		
Danger Areas of the Engines - Ground Idle Power		Jun 01/07
FIGURE Danger Areas of the Engines - Ground Idle Power - TRENT 900 Engines		Jun 01/07
FIGURE Danger Areas of the Engines - Ground Idle Power - GP 7200 Engines		Jun 01/07
Subject 6-3-2		
Danger Areas of the Engines - Max. Take-Off Power		Jun 01/07
FIGURE Danger Areas of the Engines - Max Take-Off Power - TRENT 900 Engines		Jun 01/07
FIGURE Danger Areas of the Engines - Max Take-Off Power - GP 7200 Engines		Jun 01/07
Subject 6-3-3		

CONTENT	CHG CODE	LAST REVISION DATE
Danger Areas of the Engines - Breakaway Power		Jun 01/07
FIGURE Danger Areas of the Engines - Breakaway Power - TRENT 900 Engines		Jun 01/07
FIGURE Danger Areas of the Engines - Breakaway Power - GP 7200 Engines		Jun 01/07
Subject 6-4-0		
APU Exhaust Velocities and Temperatures		Jun 01/07
Subject 6-4-1		
APU Exhaust Velocities and Temperatures		Jun 01/07
FIGURE APU Exhaust Velocities and Temperatures - Max. ECS Conditions		Jun 01/07
Subject 6-4-2		
APU Exhaust Velocities and Temperatures - MES Conditions		Jun 01/07
FIGURE APU Exhaust Velocities and Temperatures - MES Conditions		Jun 01/07
<u>CHAPTER 7</u>		
Subject 7-1-0		
General Information	R	Nov 01/08
Subject 7-2-0		
Landing Gear Footprint - Pax	R	Nov 01/08
FIGURE Landing Gear Footprint - MRW 512 000 kg - A380-800 Models	N	Nov 01/08
FIGURE Landing Gear Footprint - MRW 562 000 kg - A380-800 Models	N	Nov 01/08
FIGURE Landing Gear Footprint - MRW 571 000 kg - A380-800 Models	N	Nov 01/08
Landing Gear Footprint - Freighter	R	Nov 01/08
FIGURE Landing Gear Footprint - MRW 592 000 kg - A380-800F Models	N	Nov 01/08
FIGURE Landing Gear Footprint - MRW 602 000 kg - A380-800F Models	N	Nov 01/08
Subject 7-3-0		
Maximum Pavement Loads - Pax	R	Nov 01/08

CONTENT	CHG CODE	LAST REVISION DATE
FIGURE Maximum Pavement Loads - MRW 512 000 kg - A380-800 Models	N	Nov 01/08
FIGURE Maximum Pavement Loads - MRW 562 000 kg - A380-800 Models	R	Nov 01/08
FIGURE Maximum Pavement Loads - MRW 571 000 kg - A380-800 Models	R	Nov 01/08
Maximum Pavement Loads - Freighter		Jun 01/07
FIGURE Maximum Pavement Loads - Freighter - MRW 592 000 kg - A380-800F Models	R	Nov 01/08
FIGURE Maximum Pavement Loads - MRW 602 000 kg- A380-800F Models	R	Nov 01/08
Subject 7-4-0		
Landing Gear Loading on Pavement	R	Nov 01/08
Subject 7-4-1		
Landing Gear Loading on Pavement - Pax	R	Nov 01/08
FIGURE Landing Gear Loading on Pavement - MRW 512 000 kg - A380-800 Models	N	Nov 01/08
FIGURE Landing Gear Loading on Pavement - MRW 562 000 kg - A380-800 Models	N	Nov 01/08
FIGURE Landing Gear Loading on Pavement - MRW 571 000 kg - A380-800 Models	N	Nov 01/08
Landing Gear Loading on Pavement - Freighter	R	Nov 01/08
FIGURE Landing Gear Loading on Pavement - MRW 592 000kg - A380-800F Models	N	Nov 01/08
FIGURE Landing Gear Loading on Pavement - MRW 602 000kg - A380-800F Models	N	Nov 01/08
Subject 7-4-2		
Wing Gear and Body Gear Loading on Pavement	R	Nov 01/08
Subject 7-4-3		
Wing Gear and Body Gear Loading on Pavement - Pax	R	Nov 01/08
FIGURE Wing Gear and Body Gear Loads on Pavement - MRW 512 000 kg - A380-800 Models	N	Nov 01/08
FIGURE Wing Gear and Body Gear Loads on Pavement - MRW 562 000 kg - A380-800 Models	N	Nov 01/08

CONTENT	CHG CODE	LAST REVISION DATE
FIGURE Wing Gear and Body Gear Loads on Pavement - MRW 571 000 kg - A380-800 Models	N	Nov 01/08
Wing Gear and Body Gear Loading on Pavement - Freighter	R	Nov 01/08
FIGURE Wing Gear and Body Gear Loads on Pavement - MRW 592 000 kg - A380-800F Models	N	Nov 01/08
FIGURE Wing Gear and Body Gear Loads on Pavement - MRW 602 000 kg - A380-800F Models	N	Nov 01/08
Subject 7-5-0		
Flexible Pavement Requirements - US Army Corps of Engineers Design Method	R	Nov 01/08
Subject 7-5-1		
Flexible Pavement Requirements - US Army Corps of Engineers Design Method - Pax	R	Nov 01/08
FIGURE Flexible Pavement Requirements – 4 Wheel Bogie - MRW 512 000 kg - A380-800 Models	N	Nov 01/08
FIGURE Flexible Pavement Requirements – 6 Wheel Bogie - MRW 512 000 kg - A380-800 Models	N	Nov 01/08
FIGURE Flexible Pavement Requirements – 4 Wheel Bogie - MRW 562 000 kg - A380-800 Models	N	Nov 01/08
FIGURE Flexible Pavement Requirements – 6 Wheel Bogie - MRW 562 000 kg - A380-800 Models	R	Nov 01/08
FIGURE Flexible Pavement Requirements – 4 Wheel Bogie - MRW 571 000 kg - A380-800 Models	N	Nov 01/08
FIGURE Flexible Pavement Requirements – 6 Wheel Bogie - MRW 571 000 kg - A380-800 Models	R	Nov 01/08
Flexible Pavement Requirements - US Army Corps of Engineers Design Method - Freighter	R	Nov 01/08
FIGURE Flexible Pavement Requirements – 4 Wheel Bogie - MRW 592 000 kg - A380-800F Models	N	Nov 01/08
FIGURE Flexible Pavement Requirements – 6 Wheel Bogie - MRW 592 000 kg - A380-800F Models	R	Nov 01/08
FIGURE Flexible Pavement Requirements – 4 Wheel Bogie - MRW 602 000 kg - A380-800F Models	N	Nov 01/08

CONTENT	CHG CODE	LAST REVISION DATE
FIGURE Flexible Pavement Requirements – 6 Wheel Bogie - MRW 602 000 kg - A380-800F Models Subject 7-6-0	R	Nov 01/08
General	R	Nov 01/08
Subject 7-6-1		
Flexible Pavement Requirements - LCN Conversion - Pax	R	Nov 01/08
FIGURE Flex Pavement Requirements LCN - 4 Wheel Bogie - MRW 512 000 kg - A380-800 Models	N	Nov 01/08
FIGURE Flex Pavement Requirements LCN - 6 Wheel Bogie - MRW 512 000 kg - A380-800 Models	N	Nov 01/08
FIGURE Flex Pavement Requirements LCN - 4 Wheel Bogie - MRW 562 000 kg - A380-800 Models	R	Nov 01/08
FIGURE Flex Pavement Requirements LCN - 6 Wheel Bogie - MRW 562 000 kg - A380-800 Models	R	Nov 01/08
FIGURE Flex Pavement Requirements LCN - 4 Wheel Bogie - MRW 571 000 kg - A380-800 Models	R	Nov 01/08
FIGURE Flex Pavement Requirements LCN - 6 Wheel Bogie - MRW 571 000 kg - A380-800 Models	R	Nov 01/08
For A380-800F Models Flexible Pavement Requirements - LCN Conversion - Freighter		Jun 01/07
FIGURE Flex Pavement Requirements LCN - 4 Wheel Bogie - MRW 592 000 kg - A380-800F Models	R	Nov 01/08
FIGURE Flex Pavement Requirements LCN - 6 Wheel Bogie - MRW 592 000 kg - A380-800F Models	R	Nov 01/08
FIGURE Flex Pavement Requirements LCN - 4 Wheel Bogie - MRW 602 000 kg - A380-800F Models	R	Nov 01/08
FIGURE Flex Pavement Requirements LCN - 6 Wheel Bogie - MRW 602 000 kg - A380-800F Models	R	Nov 01/08
Subject 7-7-0		
Rigid Pavement Requirements - Portland Cement Association Design Method	R	Nov 01/08
Subject 7-7-1		

CONTENT	CHG CODE	LAST REVISION DATE
Rigid Pavement Requirements - Portland Cement Association Design Method - Pax	R	Nov 01/08
FIGURE Rigid Pavement Requirements - 4 Wheel Bogie - MRW 512 000 kg - A380-800 Models	N	Nov 01/08
FIGURE Rigid Pavement Requirements - 6 Wheel Bogie - MRW 512 000 kg - A380-800 Models	N	Nov 01/08
FIGURE Rigid Pavement Requirements - 4 Wheel Bogie - MRW 562 000 kg - A380-800 Models	N	Nov 01/08
FIGURE Rigid Pavement Requirements - 6 Wheel Bogie - MRW 562 000 kg - A380-800 Models	R	Nov 01/08
FIGURE Rigid Pavement Requirements - 4 Wheel Bogie - MRW 571 000 kg - A380-800 Models	N	Nov 01/08
FIGURE Rigid Pavement Requirements - 6 Wheel Bogie - MRW 571 000 kg - A380-800 Models	R	Nov 01/08
Rigid Pavement Requirements - Portland Cement Association Design Method - Freighter	R	Nov 01/08
FIGURE Rigid Pavement Requirements - 4 Wheel Bogie - MRW 592 000 kg - A380-800F Models	N	Nov 01/08
FIGURE Rigid Pavement Requirements - 6 Wheel Bogie - MRW 592 000 kg - A380-800F Models	R	Nov 01/08
FIGURE Rigid Pavement Requirements - 4 Wheel Bogie - MRW 602 000 kg - A380-800F Models	N	Nov 01/08
FIGURE Rigid Pavement Requirements - 6 Wheel Bogie - MRW 602 000 kg - A380-800F Models	R	Nov 01/08
Subject 7-8-0		
Rigid Pavement Requirements - LCN Conversion	R	Nov 01/08
Subject 7-8-1		
Radius of Relative Stiffness		Jun 01/07
FIGURE Radius of Relative Stiffness - Radius of Relative Stiffness		Jun 01/07
Subject 7-8-2		
Rigid Pavement Requirements - LCN Conversion - Pax	R	Nov 01/08
FIGURE Rigid Pavement Requirements LCN - 4 Wheel Bogie - MRW 512 000 kg - A380-800 Models	N	Nov 01/08

CONTENT	CHG CODE	LAST REVISION DATE
FIGURE Rigid Pavement Requirements LCN - 6 Wheel Bogie - MRW 512 000 kg - A380-800 Models	N	Nov 01/08
FIGURE Rigid Pavement Requirements LCN - 4 Wheel Bogie - MRW 562 000 kg - A380-800 Models	R	Nov 01/08
FIGURE Rigid Pavement Requirements LCN - 6 Wheel Bogie - MRW 562 000 kg - A380-800 Models	R	Nov 01/08
FIGURE Rigid Pavement Requirements LCN - 4 Wheel Bogie - MRW 571 000 kg - A380-800 Models	R	Nov 01/08
FIGURE Rigid Pavement Requirements LCN - 6 Wheel Bogie - MRW 571 000 kg - A380-800 Models	R	Nov 01/08
Rigid Pavement Requirements - LCN Conversion - Freighter		Jun 01/07
FIGURE Rigid Pavement Requirements LCN - 4 Wheel Bogie - MRW 592 000 kg - A380-800F Models	R	Nov 01/08
FIGURE Rigid Pavement Requirements LCN - 6 Wheel Bogie - MRW 592 000 kg - A380-800F Models	R	Nov 01/08
FIGURE Rigid Pavement Requirements LCN - 4 Wheel Bogie - MRW 602 000 kg - A380-800F Models	R	Nov 01/08
FIGURE Rigid Pavement Requirements LCN - 6 Wheel Bogie - MRW 602 000 kg - A380-800F Models	R	Nov 01/08
Subject 7-8-3		
Radius of Relative Stiffness (Other values of E and μ)	R	Nov 01/08
Subject 7-8-4		
Radius of Relative Stiffness (Other values of E and μ)	R	Nov 01/08
FIGURE Radius of Relative Stiffness - Radius of Relative Stiffness		Jun 01/07
Subject 7-9-0		
ACN/PCN Reporting System	R	Nov 01/08
Subject 7-9-1		
Aircraft Classification Number - Flexible Pavement - Pax	R	Nov 01/08
FIGURE Aircraft Classification Number - Flexible Pavement - MRW 512 000 kg - A380-800 Models	N	Nov 01/08
FIGURE Aircraft Classification Number - Flexible Pavement - MRW 562 000 kg - A380-800 Models	N	Nov 01/08

CONTENT	CHG CODE	LAST REVISION DATE
FIGURE Aircraft Classification Number - Flexible Pavement - MRW 571 000 kg - A380-800 Models	N	Nov 01/08
Aircraft Classification Number - Flexible Pavement - Freighter	R	Nov 01/08
FIGURE Aircraft Classification Number - Flexible Pavement - MRW 592 000 kg - A380-800F Models	N	Nov 01/08
FIGURE Aircraft Classification Number - Flexible Pavement - MRW 602 000 kg - A380-800F Models	N	Nov 01/08
Subject 7-9-2		
Aircraft Classification Number - Rigid Pavement - Pax	R	Nov 01/08
FIGURE Aircraft Classification Number - Rigid Pavement - MRW 512 000 kg - A380-800 Models	N	Nov 01/08
FIGURE Aircraft Classification Number - Rigid Pavement - MRW 562 000 kg - A380-800 Models	N	Nov 01/08
FIGURE Aircraft Classification Number - Rigid Pavement - MRW 571 000 kg - A380-800 Models	N	Nov 01/08
Aircraft Classification Number - Rigid Pavement - Freighter	R	Nov 01/08
FIGURE Aircraft Classification Number - Rigid Pavement - MRW 592 000 kg - A380-800F Models	N	Nov 01/08
FIGURE Aircraft Classification Number - Rigid Pavement - MRW 602 000 kg - A380-800F Models	N	Nov 01/08
<u>CHAPTER 8</u>		
Subject 8-1-0		
Possible Future Derivative Airplanes		Jun 01/07
<u>CHAPTER 9</u>		
Subject 9-1-0		
Scaled Drawing - 1 cm. = 500 cm.		Jun 01/07
FIGURE Scaled Drawing – 1 cm = 500 cm - A380-800 Models		Jun 01/07
FIGURE Scaled Drawing – 1 cm = 500 cm - A380-800F Models		Jun 01/07
FIGURE Scaled Drawing – 1 cm = 500 cm - A380-800 Models		Jun 01/07
FIGURE Scaled Drawing – 1 cm = 500 cm - A380-800F Models		Jun 01/07
Subject 9-2-0		



AIRPLANE CHARACTERISTICS

CONTENT	CHG CODE	LAST REVISION DATE
Scaled Drawing - 1 in. = 50 ft.		Jun 01/07
FIGURE Scaled Drawing - 1 in = 50 ft - A380-800 Models		Jun 01/07
FIGURE Scaled Drawing - 1 in = 50 ft - A380-800F Models		Jun 01/07
FIGURE Scaled Drawing - 1 in = 50 ft - A380-800 Models		Jun 01/07
FIGURE Scaled Drawing - 1 in = 50 ft - A380-800F Models		Jun 01/07

TABLE OF CONTENTS

1	SCOPE
1-1-0	Purpose
1-2-0	Introduction
1-2-1	Glossary
2	AIRPLANE DESCRIPTION
2-1-0	General Airplane Characteristics
2-1-1	General Airplane Characteristics Data
2-2-0	General Airplane Dimensions
2-3-0	Ground Clearances
2-4-0	Interior Arrangement - Plan View
2-4-1	Standard Configuration
2-5-0	Interior Arrangements - Cross Section
2-5-1	Typical Configuration
2-6-0	Cargo Compartments
2-6-1	Location and Dimensions
2-6-2	Loading Combinations
2-7-0	Door Clearances
2-7-1	Forward Doors
2-7-2	Main and Upper Deck Doors
2-7-3	Aft Doors
2-7-4	Aft Cargo Compartment Doors
2-7-5	Forward Cargo Compartment Doors
2-7-6	Nose Landing Gear Doors
2-7-7	Wing Landing Gear Doors
2-7-8	Body Landing Gear Doors
2-7-9	APU Doors
3	AIRPLANE PERFORMANCE
3-1-0	General Information
3-2-0	Payload / Range
3-2-1	ISA Conditions
3-3-0	Take Off Weight Limitation
3-3-1	ISA Conditions
3-3-2	ISA + 15 °C (59 °F)

3-4-0	Landing Field Length
3-4-1	Landing Field Length
3-5-0	Final Approach Speed
3-5-1	Final Approach Speed
4	GROUND MANEUVERING
4-1-0	General Information
4-2-0	Turning Radii
4-3-0	Minimum Turning Radii
4-4-0	Visibility from Cockpit in Static Position
4-5-0	Runway and Taxiway Turn Paths
4-5-1	135° Turn - Runway to Taxiway
4-5-2	90° Turn - Runway to Taxiway
4-5-3	180° Turn on a Runway
4-5-4	90° Turn - Taxiway to Taxiway
4-5-5	135° Turn - Taxiway to Taxiway
4-6-0	Runway Holding Bay (Apron)
4-7-0	Airplane Parking
4-8-0	Airplane Mooring
5	TERMINAL SERVICING
5-1-0	Airplane Servicing Arrangements
5-1-1	Typical Ramp Layout - Two Bridges - Standard Servicing Via Main Deck and Upper Deck
5-1-2	Typical Ramp Layout - Two Bridges - Servicing Via Main Deck
5-1-3	Opportunities of Direct Upper Deck Access for Airport and Airlines
5-1-4	Baseline Ramp Layout
5-2-0	Terminal Operation - Passenger Aircraft
5-2-1	Typical Turn-Round Time - Two Bridges - Standard Servicing Via Main Deck and Upper Deck
5-2-2	Typical Turn-Round Time - Two Bridges - Servicing Via Main Deck
5-3-0	Terminal Operation - Cargo Aircraft
5-3-1	Typical Turn-Round Time
5-4-0	Ground Service Connections
5-4-1	Ground Service Connections Layout
5-4-2	Grounding Points
5-4-3	Hydraulic System
5-4-4	Electrical System
5-4-5	Oxygen System

5-4-6	Fuel System
5-4-7	Pneumatic System
5-4-8	Potable Water System
5-4-9	Oil System
5-4-10	Vacuum Toilet System
5-5-0	Engine Starting Pneumatic Requirements
5-5-1	Outside Air Temperature = -40 °C (-40 °F)
5-5-2	Outside Air Temperature = 15 °C (59 °F)
5-5-3	Outside Air Temperature = 50 °C (122 °F)
5-6-0	Ground Pneumatic Power Requirements
5-6-1	Heating
5-6-2	Cooling
5-7-0	Preconditioned Airflow Requirements
5-8-0	Ground Towing Requirements
6	OPERATING CONDITIONS
6-1-0	Engine Exhaust Velocities and Temperatures
6-1-1	Engine Exhaust Velocities - Ground Idle Power
6-1-2	Engine Exhaust Temperatures - Ground Idle Power
6-1-3	Engine Exhaust Velocities - Breakaway Power
6-1-4	Engine Exhaust Temperatures - Breakaway Power
6-1-5	Engine Exhaust Velocities - Max Take-off Power
6-1-6	Engine Exhaust Temperatures - Max Take-off Power
6-2-0	Airport and Community Noise Data
6-2-1	Airport and Community Noise Data
6-3-0	Danger Areas of the Engines
6-3-1	Danger Areas of the Engines - Ground Idle Power
6-3-2	Danger Areas of the Engines - Max. Take-Off Power
6-3-3	Danger Areas of the Engines - Breakaway Power
6-4-0	APU Exhaust Velocities and Temperatures
6-4-1	APU Exhaust Velocities and Temperatures
6-4-2	APU Exhaust Velocities and Temperatures - MES Conditions
7	PAVEMENT DATA
7-1-0	General Information
7-2-0	Landing Gear Footprint
7-3-0	Maximum Pavement Loads
7-4-0	Landing Gear Loading on Pavement

7-4-1	Landing Gear Loading on Pavement
7-4-2	Wing Gear and Body Gear Loading on Pavement
7-4-3	Wing Gear and Body Gear Loading on Pavement
7-5-0	Flexible Pavement Requirements - US Army Corps of Engineers Design Method
7-5-1	Flexible Pavement Requirements - US Army Corps of Engineers Design Method S-77-1
7-6-0	Flexible Pavement Requirements - LCN Conversion
7-6-1	Flexible Pavement Requirements - LCN Conversion
7-7-0	Rigid Pavement Requirements - Portland Cement Association Design Method
7-7-1	Rigid Pavement Requirements - Portland Cement Association Design Method
7-8-0	Rigid Pavement Requirements - LCN Conversion
7-8-1	Radius of Relative Stiffness
7-8-2	Rigid Pavement Requirements - LCN Conversion
7-8-3	Radius of Relative Stiffness (Other values of E and μ)
7-8-4	Radius of Relative Stiffness (Other values of E and μ)
7-9-0	ACN/PCN Reporting System
7-9-1	Aircraft Classification Number - Flexible Pavement
7-9-2	Aircraft Classification Number - Rigid Pavement

8 DERIVATIVE AIRPLANES

8-1-0	Possible Future Derivative Airplanes
-------	--------------------------------------

9 SCALED DRAWINGS

9-1-0	Scaled Drawing - 1 cm. = 500 cm.
9-2-0	Scaled Drawing - 1 in. = 50 ft.

SCOPE**1-1-0 Purpose******ON A/C A380-800 Models A380-800F Models**Purpose

1. General

This A380 AIRPLANE CHARACTERISTICS (AC) manual is issued for the A380-800 and A380-800F series aircraft to provide necessary data to airport operators and airlines for airport facilities planning.

The A380-800 is a subsonic, very long range, very high capacity, civil transport aircraft.

There are two models in the A380-800 series :

- A380-841 model equipped with Rolls-Royce Trent 970 engine,
- A380-861 model equipped with Engine Alliance GP 7270 engine.

The A380-800F is a subsonic, very long range, civil freighter aircraft.

There are two models in the A380-800F series :

- A380-843F model equipped with Rolls-Royce Trent 977 engine,
- A380-863F model equipped with Engine Alliance GP 7277 engine.

In this manual, effectivity is managed as follows :

- by default, the data is effective for all A380-800 and A380-800F models,
- "A380-800/800F models" indicates that the related data or page is effective for all A380-800 and A380-800F models,
- "A380-800 models" restricts the effectivity of the related data or page to the A380-841 and A380-861 models,
- "A380-800F models" restricts the effectivity of the related data or page to the A380-843F and A380-863F models,
- the mention of a specific model (e.g. A380-841 model, A380-863F model, etc.) restricts the effectivity of the related data or page to that specific model.

This document conforms to NAS 3601.



AIRPLANE CHARACTERISTICS

CORRESPONDENCE

Correspondence concerning this publication should be directed to :

AIRBUS S.A.S.
Technical Data Support and Services
1 Rond Point Maurice BELLONTE
31707 BLAGNAC CEDEX
FRANCE

1-2-0 Introduction

****ON A/C A380-800 Models A380-800F Models**

Introduction

1. General

This manual comprises 9 chapters with a List of Effective Content (L.E.C.) and a Table Of Contents (TOC) at the beginning of the manual.

CHAPTER 1 : SCOPE

CHAPTER 2 : AIRPLANE DESCRIPTION

This chapter contains general dimensional and other basic aircraft data.

It covers :

- aircraft dimensions and ground clearances,
- passenger and cargo compartment arrangements.

CHAPTER 3 : AIRPLANE PERFORMANCE

This chapter indicates the aircraft performance.

It covers :

- payload/range,
- take-off and landing runway requirements,
- landing approach speed.

CHAPTER 4 : GROUND MANEUVERING

This chapter provides the aircraft turning capability and maneuvering characteristics on the ground.

It includes :

- turning radii and visibility from the cockpit,
- runway and taxiway turn path.

CHAPTER 5 : TERMINAL SERVICING

This chapter provides information for the arrangement of ground handling and servicing equipment.

It covers :

- location and connections of ground servicing equipment,
- engines starting pneumatic and preconditioned airflow requirements.

CHAPTER 6 : OPERATING CONDITIONS

This chapter contains data and safety/environmental precautions related to engine and APU operation on the ground.

It includes :

- engine and APU exhaust velocities and temperatures data,
- engine noise data.

CHAPTER 7 : PAVEMENT DATA

This chapter contains the pavements data helpful for airport planning.

It gives :

- landing gear foot print and static load,
- charts for flexible pavements with Load Classification Number (LCN),
- charts for rigid pavements with LCN,
- Aircraft Classification Number (ACN), Pavement Classification Number (PCN), reporting system for flexible and rigid pavements.

CHAPTER 8 : DERIVATIVE AIRPLANES

This chapter gives relevant data of a possible new version with the associated size change.

CHAPTER 9 : SCALED DRAWINGS

This chapter contains different A380-800 and A380-800F scaled drawings.

1-2-1 Glossary

****ON A/C A380-800 Models A380-800F Models**Glossary

1. List of Abbreviations

A/C Aircraft

ACN	Aircraft Classification Number
APU	Auxiliary Power Unit
BLG	Body Landing Gear
CAS	Calibrated Air Speed
CBR	California Bearing Ratio
CG	Center of Gravity
C/L	Center Line
E	Young's Modulus
FAA	Federal Aviation Administration
FDL	Fuselage Datum Line
FR	Frame
FSTE	Full Size Trolley Equivalent
FWD	Forward
GPU	Ground Power Unit
GSE	Ground Support Equipment
ICAO	International Civil Aviation Organisation
ISA	International Standard Atmosphere
L	Left
L	Radius of relative stiffness
LCN	Load Classification Number
LPS	Last Pax Seating
MAC	Mean Aerodynamic Chord
MAX	Maximum
MIN	Minimum
MLW	Maximum Design Landing Weight
MRW	Maximum Design Ramp Weight
MTOW	Maximum Design Take-Off Weight
MTW	Maximum Design Taxi Weight
MZFW	Maximum Design Zero Fuel Weight
NLG	Nose Landing Gear
OAT	Outside Air Temperature
OEW	Operational Empty Weight

PAX	Passenger
PB/D	Passenger Boarding/Deboarding
PCN	Pavement Classification Number
R	Right
SLS	Sea Level Static condition
TBD	To Be Determined
TBIL	To Be Issued Later
ULD	Unit Load Device
US	United States
VF	Variable Frequency
Vref	Landing reference speed
WLG	Wing Landing Gear

2. Units of Measurement

°	degree (angle)
%	percent
°C	degree Celsius
°F	degree Fahrenheit
bar	bar
cm	centimeter
deg	degree (angle)
ft	foot
ft/s	foot per second
ft/s ²	foot per second squared
ft ²	square foot
ft ³	cubic foot
in	inch
kg	kilogram
kg/l	kilogram per liter
km/h	kilometer per hour
kt	knot
kVA	kiloVolt Ampere
l	liter
lb	pound
m	meter
m/s	meter per second
m ²	square meter
m ³	cubic meter

min	minute
mm	millimeter
MN/m ³	MegaNewton per cubic meter
MPa	MegaPascal
nm	nautical mile
pci	pound-force per cubic inch
psi	pound-force per square inch
t	tonne
US gal	United States gallon

3. Design Weight Terminology

- Maximum Design Ramp Weight (MRW) :
Maximum weight for ground maneuver (including weight of taxi and runup fuel) as limited by aircraft strength and airworthiness requirements. It is also called Maximum Design Taxi Weight (MTW).
- Maximum Design Landing Weight (MLW) :
Maximum weight for landing as limited by aircraft strength and airworthiness requirements.
- Maximum Design Takeoff Weight (MTOW) :
Maximum weight for takeoff as limited by aircraft strength and airworthiness requirements. (This is the maximum weight at start of the take-off run).
- Maximum Design Zero Fuel Weight (MZFW) :
Maximum permissible weight of the aircraft less usable fuel.
- Operational Empty Weight (OEW) :
Weight of structure, powerplant, furnishings, systems, and other items of equipment that are an integral part of a particular aircraft configuration plus the operator's items. The operator's items are the flight and cabin crew and their baggage, unusable fuel, engine oil, emergency equipment, toilet chemical and fluids, galley structure, catering equipment, seats, documents, etc.
- Maximum Payload :
Maximum Design Zero Fuel Weight (MZFW) minus Operating Weight Empty (OWE).
- Maximum Seating Capacity :
Maximum number of passengers specifically certified or anticipated for certification.
- Maximum Cargo Volume :
Maximum usable volume available for cargo.
- Usable Fuel :
Fuel available for aircraft propulsion.



AIRPLANE CHARACTERISTICS

AIRPLANE DESCRIPTION

2-1-0 General Airplane Characteristics

**ON A/C A380-800 Models A380-800F Models

General Airplane Characteristics

1. General Airplane Characteristics

2-1-1 General Airplane Characteristics Data

****ON A/C A380-800 Models A380-800F Models**

General Airplane Characteristics data

1. The following table provides characteristics of A380-800 Models:

Aircraft Characteristics			
Airplane Model		A380-841	A380-861
Engines		TRENT 970	GP 7270
Maximum Design Ramp Weight (MRW)	kilograms	562 000	562 000
	pounds	1 238 998	1 238 998
Maximum Design Take Off Weight (MTOW)	kilograms	560 000	560 000
	pounds	1 234 588	1 234 588
Maximum Design Landing Weight (MLW)	kilograms	386 000	386 000
	pounds	850 984	850 984
Maximum Design Zero Fuel Weight (MZFW)	kilograms	361 000	361 000
	pounds	795 869	795 869
Operating Empty Weight (OEW) – Typical	kilograms	270 015	270 281
	pounds	595 281	595 868
Maximum Payload	kilograms	90 985	90 718
	pounds	200 587	199 999
Standard Seating Capacity	Three-Class	555 <1>	555 <1>
Usable Fuel Capacity	liters	310 000	310 000
	US gallons	81 893	81 893
	kilograms (density = 0.785 kg/l)	243 350	243 350
	pound	536 494	536 494
Volume of Cargo Compartments <2>	cubic meters	175.30	175.30
	cubic feet	6191	6191
Volume of Cockpit	cubic meters	12.60	12.60
	cubic feet	444.96	444.96

<1> 555 pax :

- main deck : First Class 22 and Tourist Class 334
- upper deck : Business Class 96 and Tourist Class 103

<2> Volume of cargo compartments :

- lower deck forward cargo compartment
(usable containerised volume) : 89.4 m³ (3157 ft³)
- lower deck aft cargo compartment
(usable containerised volume) : 71.5 m³ (2525 ft³)

- lower bulk cargo compartment
(usable volume) : 14.4 m³ (505 ft³)

2. The following table provides characteristics of A380-800F Models.

Aircraft Characteristics			
Airplane Model		A380-843F	A380-863F
Engines		TRENT 977	GP 7277
Maximum Design Ramp Weight (MRW)	kilograms	592 000	592 000
	pounds	1 305 136	1 305 136
Maximum Design Take Off Weight (MTOW)	kilograms	590 000	590 000
	pounds	1 300 727	1 300 727
Maximum Design Landing Weight (MLW)	kilograms	427 000	427 000
	pounds	941 374	941 374
Maximum Design Zero Fuel Weight (MZFW)	kilograms	402 000	402 000
	pounds	886 258	886 258
Operating Empty Weight (OEW) – Typical	kilograms	250 560	250 826
	pounds	552 390	552 976
Maximum Payload	kilograms	151 440	151 174
	pounds	333 868	333 281
Usable Fuel Capacity	liters	310 000 <2>	310 000 <2>
	US gallons	81 893	81 893
	kilograms (density = 0.785 kg/l)	243 350	243 350
	pounds	536 494	536 494
Volume of Cargo Compartments <1>	cubic meters	938.4	938.4
	cubic feet	33 139	33 139
Volume of Cockpit	cubic meters	12.60	12.60
	cubic feet	444.96	444.96

<1> Volume of cargo compartments :

- lower deck forward cargo compartment
(usable containerised volume) : 90 m³ (3 157 ft³)
- lower deck aft cargo compartment
(usable containerised volume) : 72 m³ (2 525 ft³)
- lower bulk cargo compartment
(usable volume) : 18.4 m³ (650 ft³)
- main deck cargo compartment
(usable palletized volume) : 508 m³ (18 222 ft³)
- upper deck cargo compartment
(usable palletized volume) : 250 m³ (9 075 ft³)



AIRPLANE CHARACTERISTICS

<2> Usable fuel capacity with center tank : 355 850 l (94 005 US gal)



AIRPLANE CHARACTERISTICS

2-2-0 General Airplane Dimensions

****ON A/C A380-800 Models A380-800F Models**

General Airplane Dimensions Data

1. This section provides General Airplane Dimensions.

**ON A/C A380-800 Models A380-800F Models

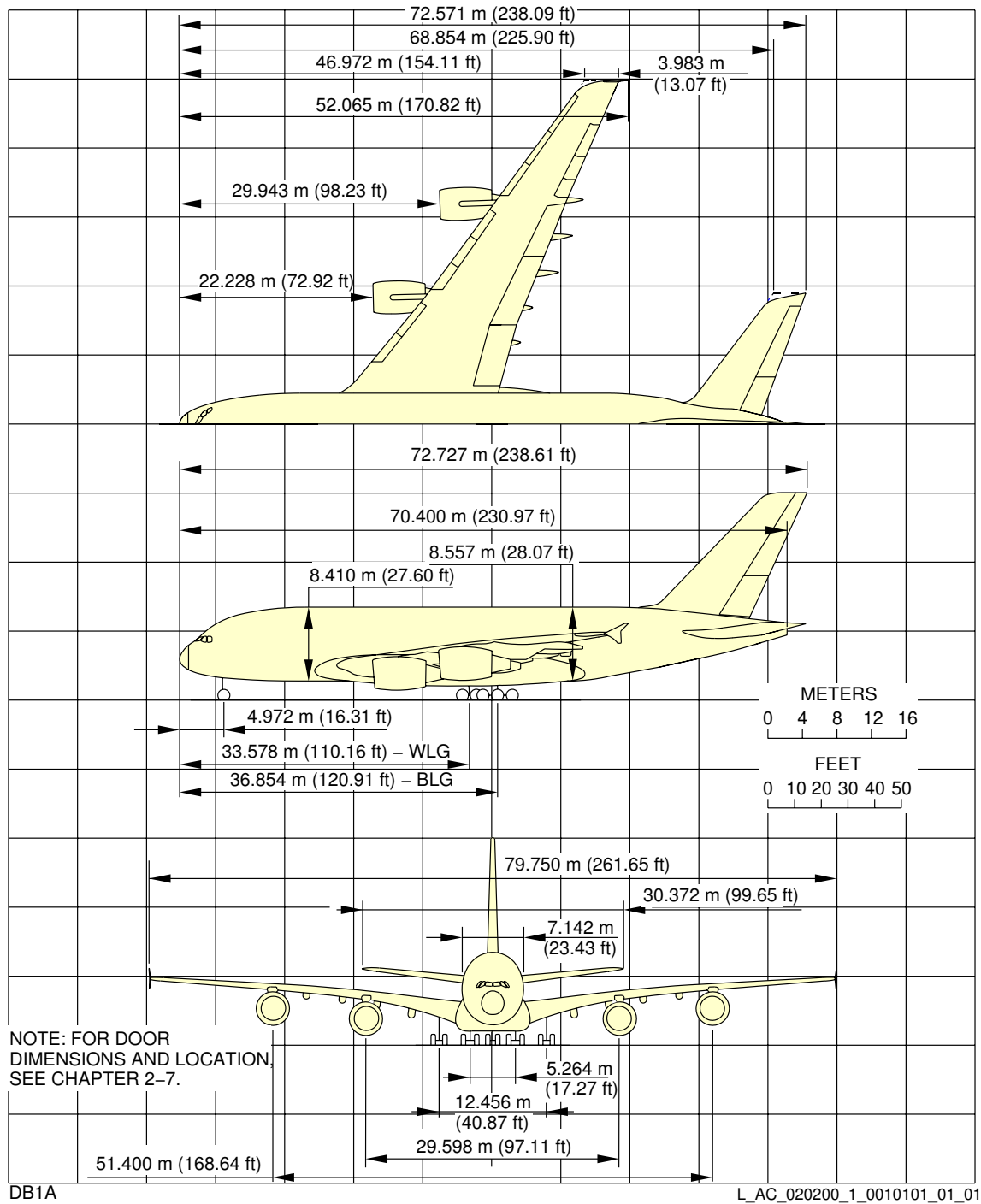

General Airplane Dimensions



AIRPLANE CHARACTERISTICS

2-3-0 Ground Clearances

****ON A/C A380-800 Models**

Ground Clearances - Pax

1. This section gives ground clearances of A380-800 Models.

****ON A/C A380-800 Models**

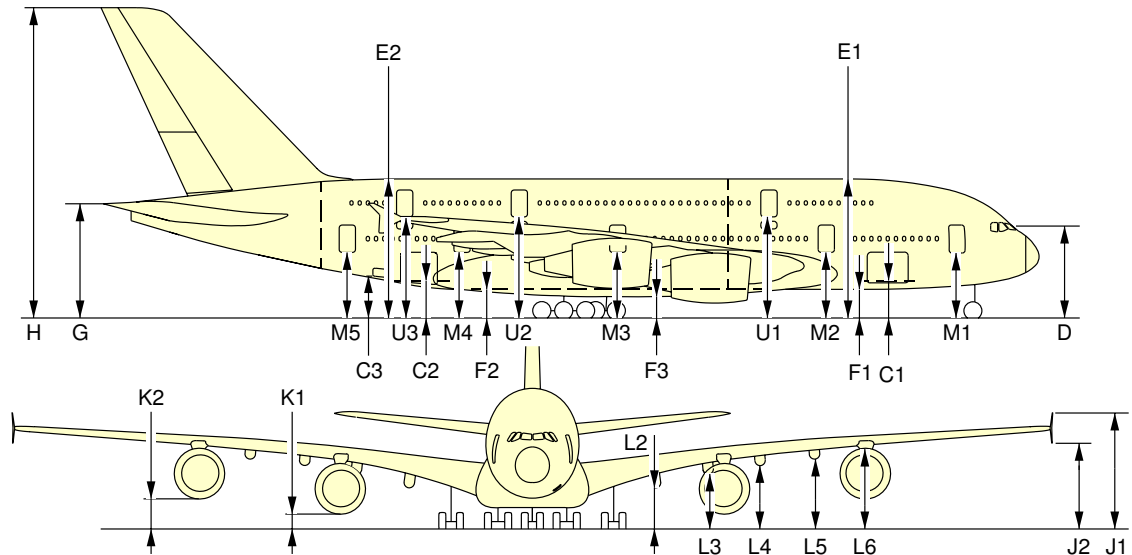

A/C CONFIGURATION	MRW (562t) FWD CG		MRW AFT CG		300t AFT CG		290t MID CG		A/C JACKED FDL = 7.2 m (23.6 ft)	
	m	ft	m	ft	m	ft	m	ft	m	ft
C1	3.05	10.0	3.11	10.2	3.30	10.8	3.19	10.5	5.12	16.8
C2	3.14	10.3	3.10	10.2	3.23	10.6	3.32	10.9	5.12	16.8
C3	3.27	10.7	3.22	10.6	3.36	11.0	3.43	11.3	5.24	17.2
D	7.13	23.4	7.21	23.7	7.42	24.3	7.25	23.8	9.22	30.2
E1	10.76	35.3	10.81	35.5	11.00	36.1	10.90	35.8	12.82	42.1
E2	10.84	35.6	10.80	35.4	10.93	35.9	11.03	36.2	12.82	42.1
F1	2.35	7.7	2.40	7.9	2.59	8.5	2.49	8.2	4.41	14.5
F2	2.27	7.5	2.24	7.4	2.38	7.8	2.46	8.1	4.27	14.0
F3	1.66	5.4	1.66	5.5	1.82	6.0	1.82	6.0	3.68	12.1
G	9.21	30.2	9.11	29.9	9.20	30.2	9.43	30.9	11.14	36.6
H	24.18	79.3	24.08	79.0	24.17	79.3	24.40	80.1	26.11	85.7
J1	7.55	24.8	7.50	24.6	8.22	27.0	8.33	27.3	10.12	33.2
J2	5.27	17.3	5.22	17.1	5.94	19.5	6.05	19.8	7.84	25.7
K1	1.05	3.5	1.08	3.5	1.30	4.2	1.25	4.1	3.14	10.3
K2	1.90	6.2	1.90	6.2	2.27	7.4	2.27	7.5	4.13	13.5
L2	3.08	10.1	3.07	10.1	3.26	10.7	3.27	10.7	5.12	16.8
L3	4.10	13.4	4.08	13.4	4.31	14.1	4.34	14.2	6.18	20.3
L4	4.67	15.3	4.65	15.3	4.93	16.2	4.98	16.4	6.81	22.4
L5	5.01	16.4	4.99	16.4	5.34	17.5	5.40	17.7	7.22	23.7
L6	5.21	17.1	5.18	17.0	5.61	18.4	5.67	18.6	7.50	24.6
M1	5.07	16.6	5.14	16.9	5.34	17.5	5.19	17.0	7.15	23.5
M2	5.09	16.7	5.14	16.9	5.32	17.5	5.23	17.2	7.15	23.5
M3	5.13	16.8	5.13	16.8	5.29	17.3	5.29	17.4	7.15	23.5
M4	5.16	16.9	5.13	16.8	5.26	17.3	5.34	17.5	7.15	23.5
M5	5.18	17.0	5.12	16.8	5.25	17.2	5.37	17.6	7.15	23.5
U1	7.85	25.8	7.89	25.9	8.06	26.5	8.00	26.3	9.90	32.5
U2	7.90	25.9	7.88	25.9	8.03	26.3	8.07	26.5	9.90	32.5
U3	7.92	26.0	7.88	25.8	8.01	26.3	8.11	26.6	9.90	32.5

NOTE: MAXIMUM JACKING WEIGHT = 333 700 kg

L_AC_020300_1_0010101_01_01

Ground Clearances
A380-800 Models



AIRPLANE CHARACTERISTICS

****ON A/C A380-800F Models**

Ground Clearances - Freighter

1. This section gives ground clearances of A380-800F models.

**ON A/C A380-800F Models

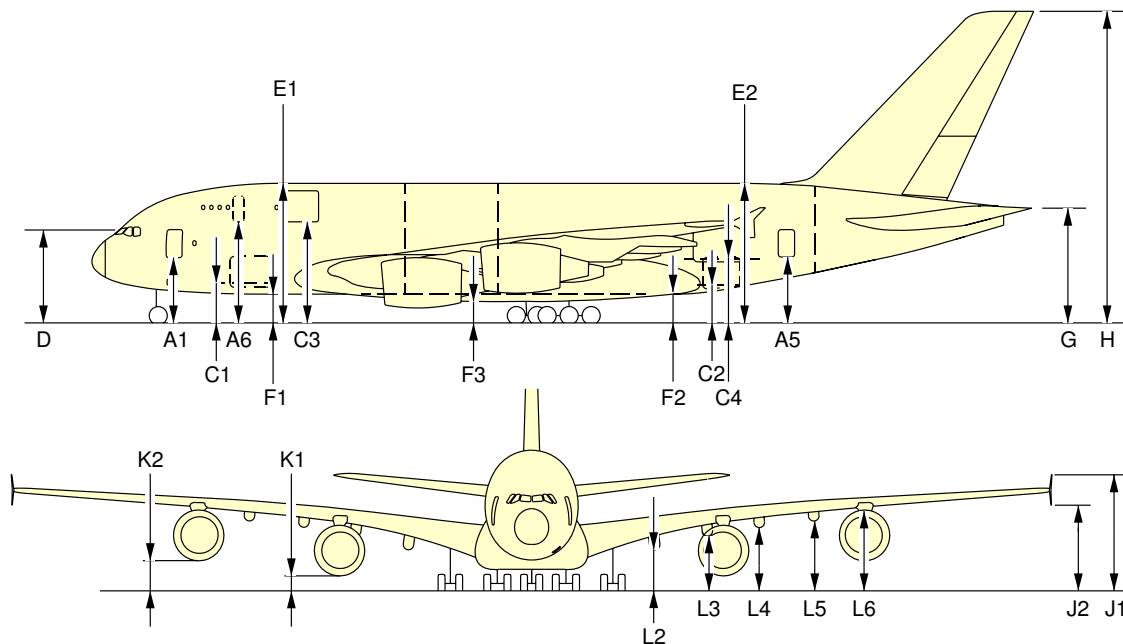

A/C CONFIGURATION	MRW FWD CG		MRW AFT CG		300t AFT CG		OWE MID CG		A/C JACKED FDL = 7.3 m (24.0 ft)	
	m	ft	m	ft	m	ft	m	ft	m	ft
A1	5.03	16.5	5.12	16.8	5.34	17.5	5.21	17.1	7.25	23.8
A5	5.16	16.9	5.10	16.7	5.24	17.2	5.41	17.7	7.25	23.8
A6	7.80	25.6	7.87	25.8	8.08	26.5	7.99	26.2	10.00	32.8
C1	3.02	9.9	3.09	10.1	3.30	10.8	3.21	10.5	5.22	17.1
C2	3.12	10.2	3.07	10.1	3.22	10.6	3.36	11.0	5.22	17.1
C3	7.93	26.0	7.99	26.2	8.19	26.9	8.12	26.6	10.12	33.2
C4	5.15	16.9	5.10	16.7	5.25	17.2	5.38	17.7	7.25	23.8
D	7.09	23.3	7.19	23.6	7.41	24.3	7.27	23.8	9.32	30.6
E1	10.73	35.2	10.79	35.4	11.00	36.1	10.92	35.8	12.92	42.4
E2	10.83	35.5	10.78	35.4	10.92	35.8	11.07	36.3	12.92	42.4
F1	2.32	7.6	2.38	7.8	2.59	8.5	2.51	8.2	4.51	14.8
F2	2.26	7.4	2.22	7.3	2.37	7.8	2.49	8.2	4.37	14.3
F3	1.63	5.4	1.64	5.4	1.81	5.9	1.85	6.1	3.78	12.4
G	9.21	30.2	9.08	29.8	9.19	30.1	9.48	31.1	11.24	36.9
H	24.18	79.3	24.05	78.9	24.16	79.3	24.45	80.2	26.21	86.0
J1	7.54	24.7	7.48	24.5	8.21	26.9	8.37	27.5	10.22	33.5
J2	5.26	17.2	5.20	17.1	5.93	19.4	6.08	20.0	7.94	26.0
K1	1.03	3.4	1.05	3.5	1.29	4.2	1.28	4.2	3.24	10.6
K2	1.88	6.2	1.88	6.2	2.26	7.4	2.30	7.5	4.23	13.9
L2	3.05	10.0	3.05	10.0	3.25	10.7	3.30	10.8	5.22	17.1
L3	4.08	13.4	4.06	13.3	4.30	14.1	4.37	14.3	6.28	20.6
L4	4.65	15.3	4.63	15.2	4.93	16.2	5.02	16.5	6.91	22.7
L5	4.99	16.4	4.96	16.3	5.33	17.5	5.43	17.8	7.32	24.0
L6	5.19	17.0	5.16	16.9	5.60	18.4	5.71	18.7	7.60	24.9

L_AC_020300_1_0030101_01_00

Ground clearances
A380-800F Models



AIRPLANE CHARACTERISTICS

2-4-0 Interior Arrangement - Plan View

****ON A/C A380-800 Models A380-800F Models**

Interior Arrangement - Plan View

1. Interior Arrangement - Plan View



AIRPLANE CHARACTERISTICS

2-4-1 Standard Configuration

****ON A/C A380-800 Models**

Standard Configuration - Pax

1. This section gives the standard configuration of A380-800 models

**ON A/C A380-800 Models

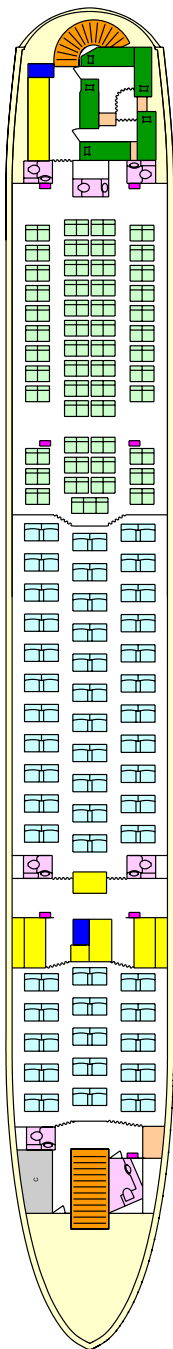

UPPER DECK

PASSENGER SEATS UPPER DECK (199 TOTAL)

- BUSINESS CLASS 96 SEATS
- TOURIST CLASS 103 SEATS
- ATTENDANT SEATS 8
- COAT STOWAGE 6
- GALLEYS 8
- LAVATORIES 7
- STOWAGES 1
- LIFT 2
- STAIRS 2
- CREW REST BUNKS 5

L_AC_020401_1_0010101_01_00

Interior Arrangements - Plan View
Standard Configuration - Upper Deck

**ON A/C A380-800 Models

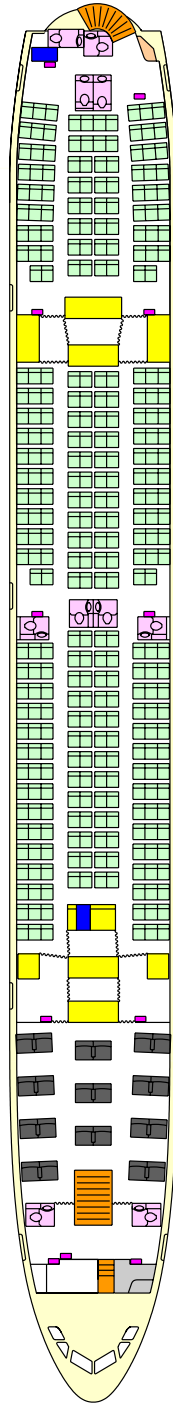

MAIN DECK

PASSENGER SEATS MAIN DECK (356 TOTAL)

- FIRST CLASS 22 SEATS
- TOURIST CLASS 334 SEATS
- ATTENDANT SEATS 12
- COAT STOWAGE 1
- GALLEYS 9
- LAVATORIES 10
- STOWAGES 1
- LIFT 2
- STAIRS 2

L_AC_020401_1_0020101_01_00

Interior Arrangements - Plan View
Standard Configuration - Main Deck



AIRPLANE CHARACTERISTICS

****ON A/C A380-800F Models**

Standard Configuration - Freighter

1. This section gives the standard configuration of A380-800F models.

**ON A/C A380-800F Models

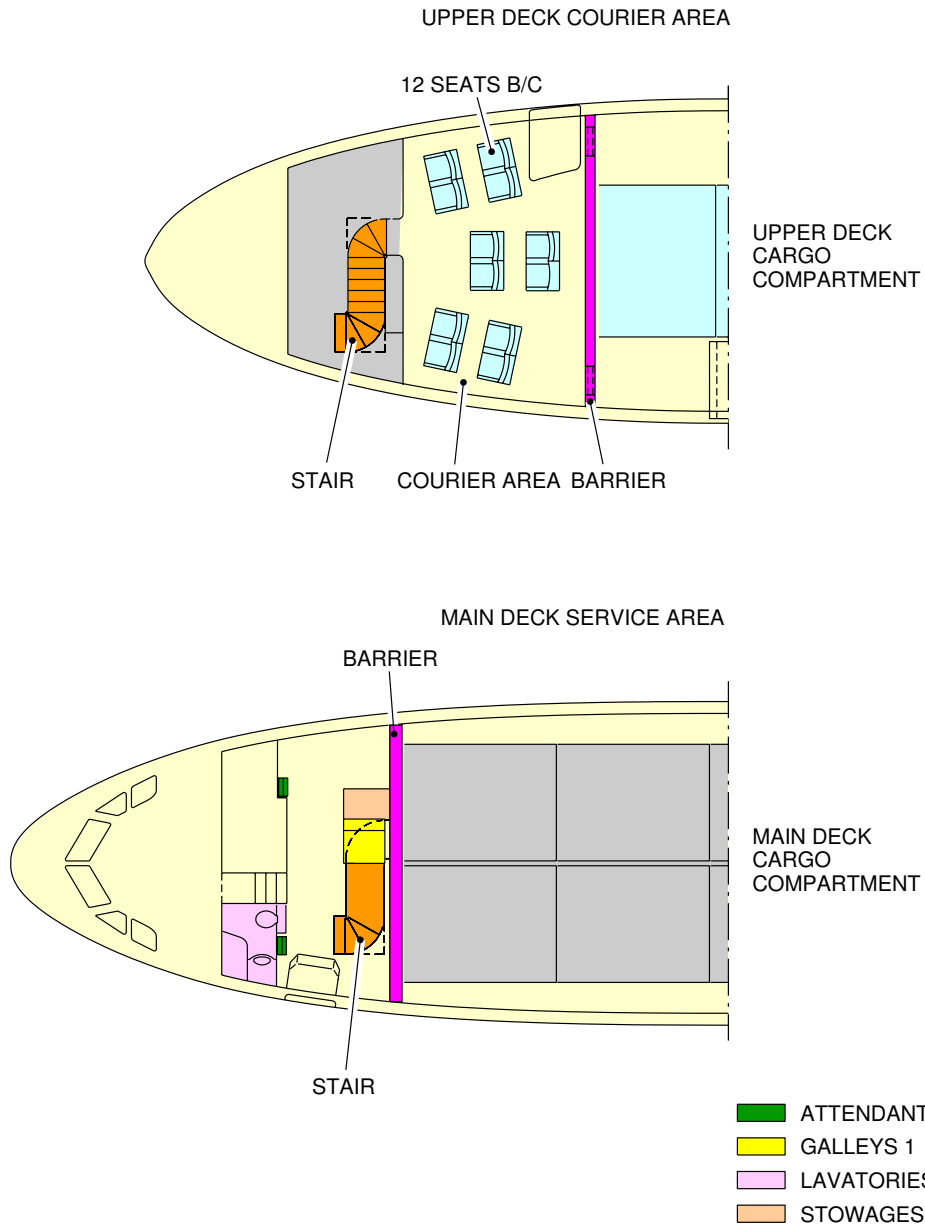

L_AC_020401_1_0030101_01_00

Interior Arrangements - Plan View
Standard Configuration



AIRPLANE CHARACTERISTICS

2-5-0 Interior Arrangements - Cross Section

**ON A/C A380-800 Models A380-800F Models

Interior Arrangements - Cross Section

1. Interior Arrangements - Cross Section



AIRPLANE CHARACTERISTICS

2-5-1 Typical Configuration

****ON A/C A380-800 Models**

Typical Configuration - Pax

1. This section gives the typical configuration of A380-800 models.

**ON A/C A380-800 Models

UPPER DECK
TOURIST CLASS 8 ABREAST

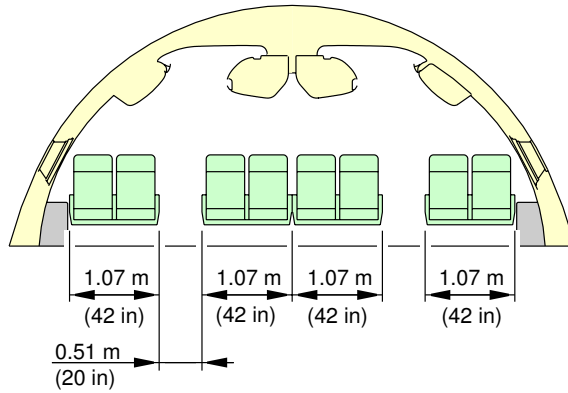

UPPER DECK
BUSINESS CLASS 6 ABREAST

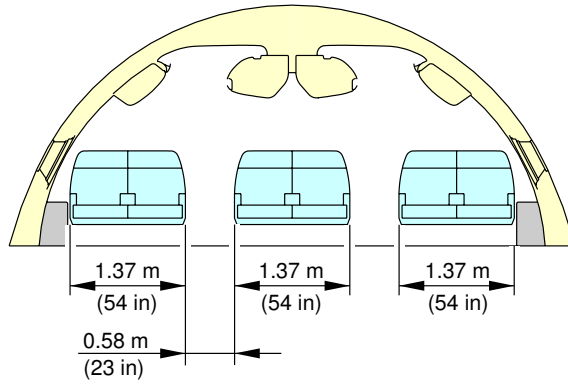

L_AC_020501_1_0010101_01_00

Interior Arrangements - Cross-section
Typical Configuration - Upper Deck

**ON A/C A380-800 Models

MAIN DECK
TOURIST CLASS 10 ABREAST

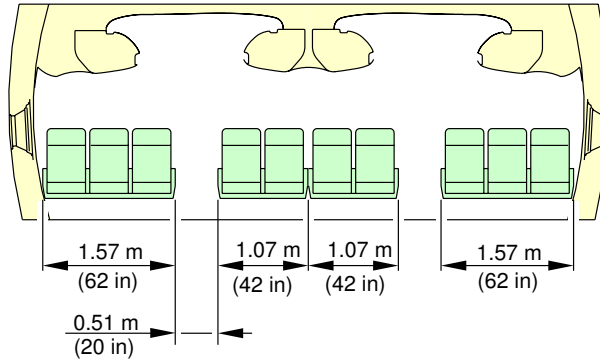

MAIN DECK
FIRST CLASS 6 ABREAST

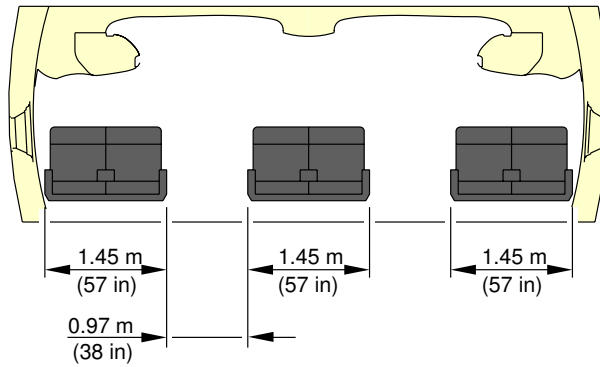

L_AC_020501_1_0020101_01_00

Interior Arrangements - Cross-section
Typical Configuration - Main Deck



AIRPLANE CHARACTERISTICS

****ON A/C A380-800F Models**

Typical Configuration - Freighter

1. This section gives the typical configuration of A380-800F models.

**ON A/C A380-800F Models

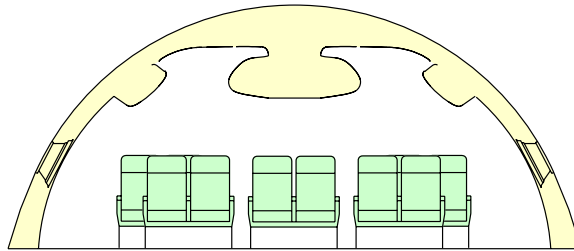

UPPER DECK
COURIER AREA

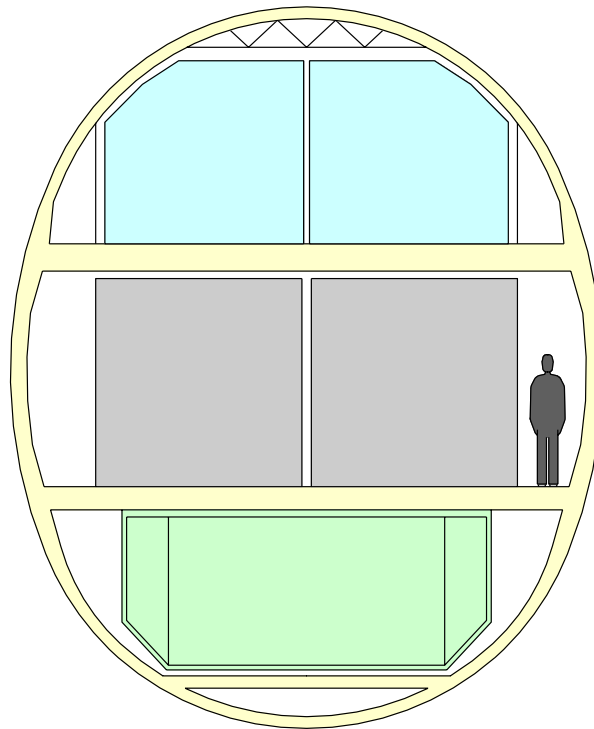

UPPER DECK
CARGO COMPARTMENT

MAIN DECK
CARGO COMPARTMENT

LOWER DECK
CARGO COMPARTMENT

L_AC_020501_1_0030101_01_00

Interior Arrangements - Cross-section
Typical Configuration - A380- 800F Models All Decks



AIRPLANE CHARACTERISTICS

2-6-0 Cargo Compartments

**ON A/C A380-800 Models A380-800F Models

Cargo Compartments

1. Cargo Compartments



AIRPLANE CHARACTERISTICS

2-6-1 Location and Dimensions

****ON A/C A380-800 Models**

Location and Dimensions - Pax

1. This section gives the cargo compartments location and dimensions of A380-800 models.

**ON A/C A380-800 Models

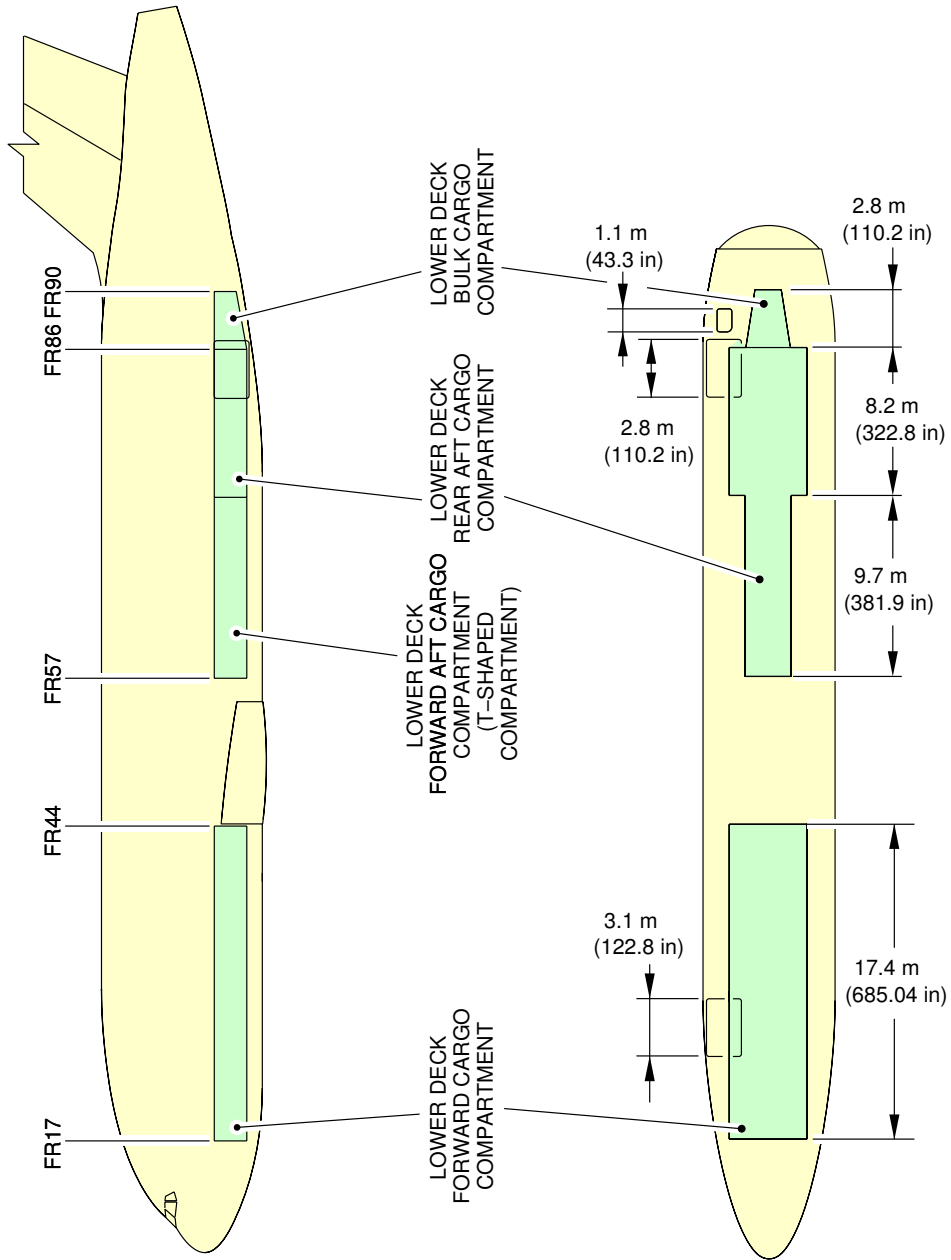

L_AC_020601_1_0010101_01_00

Cargo Compartments
Location and Dimensions



AIRPLANE CHARACTERISTICS

****ON A/C A380-800F Models**

Location and Dimensions - Freighter

1. This section gives the cargo compartments location and dimensions of A380-800F models.

**ON A/C A380-800F Models

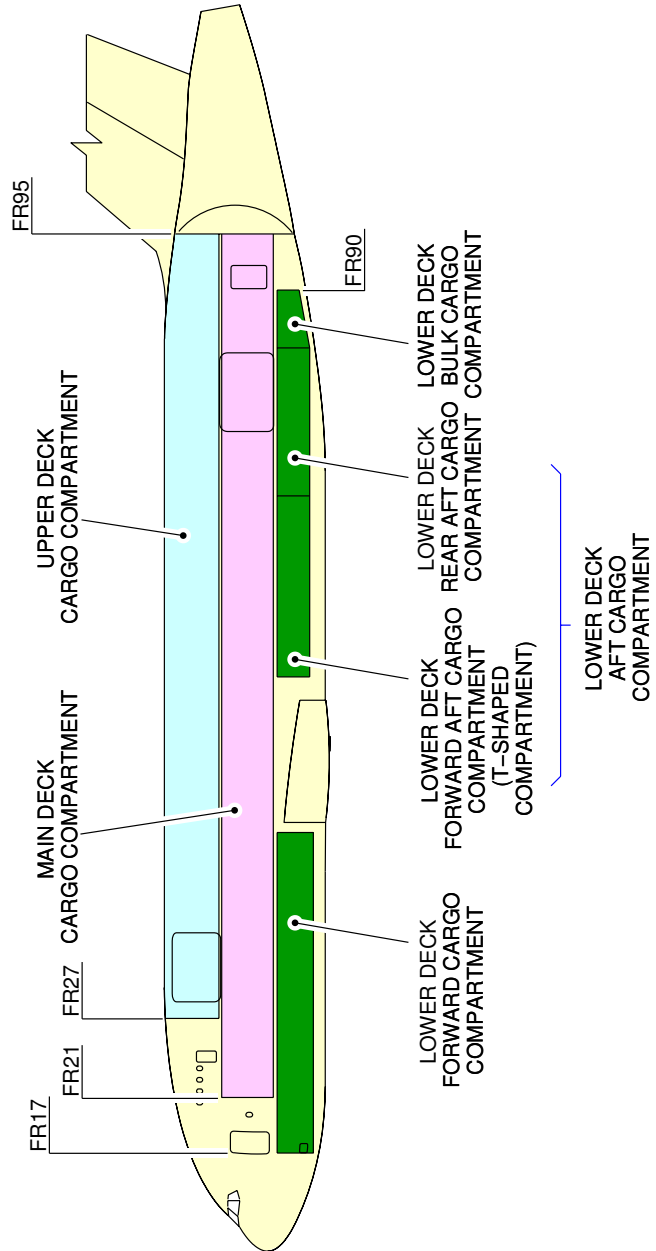

L_AC_020601_1_0020101_01_00

Cargo Compartments
Location and Dimensions (Sheet 1)

**ON A/C A380-800F Models

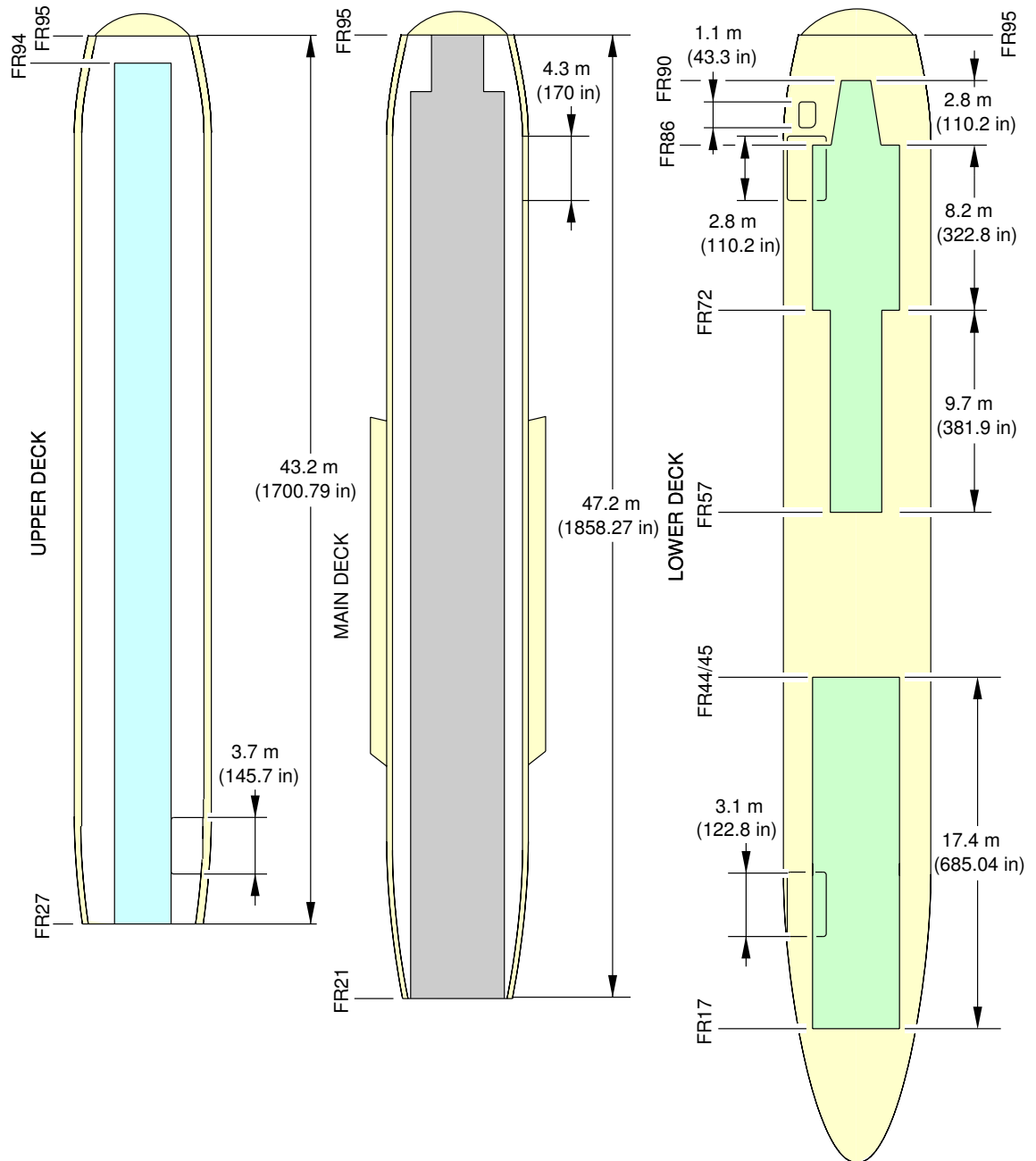

L_AC_020601_1_0030101_01_00

Cargo Compartments
Location and Dimensions (Sheet 2)



AIRPLANE CHARACTERISTICS

2-6-2 Loading Combinations

****ON A/C A380-800 Models**

Loading Combinations - Pax

1. This section gives cargo compartments loading combinations.

**ON A/C A380-800 Models

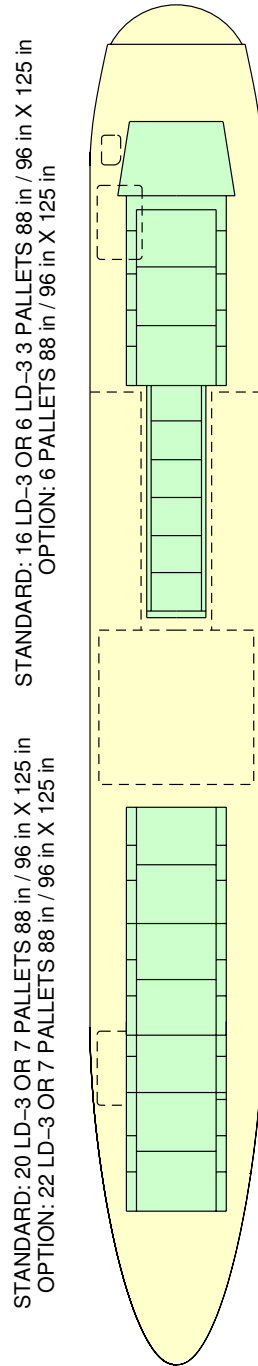

L_AC_020602_1_0010101_01_00

Cargo Compartments
Loading Combinations



AIRPLANE CHARACTERISTICS

****ON A/C A380-800F Models**

Loading Combinations - Freighter

1. This section gives cargo compartments loading combinations.

**ON A/C A380-800F Models

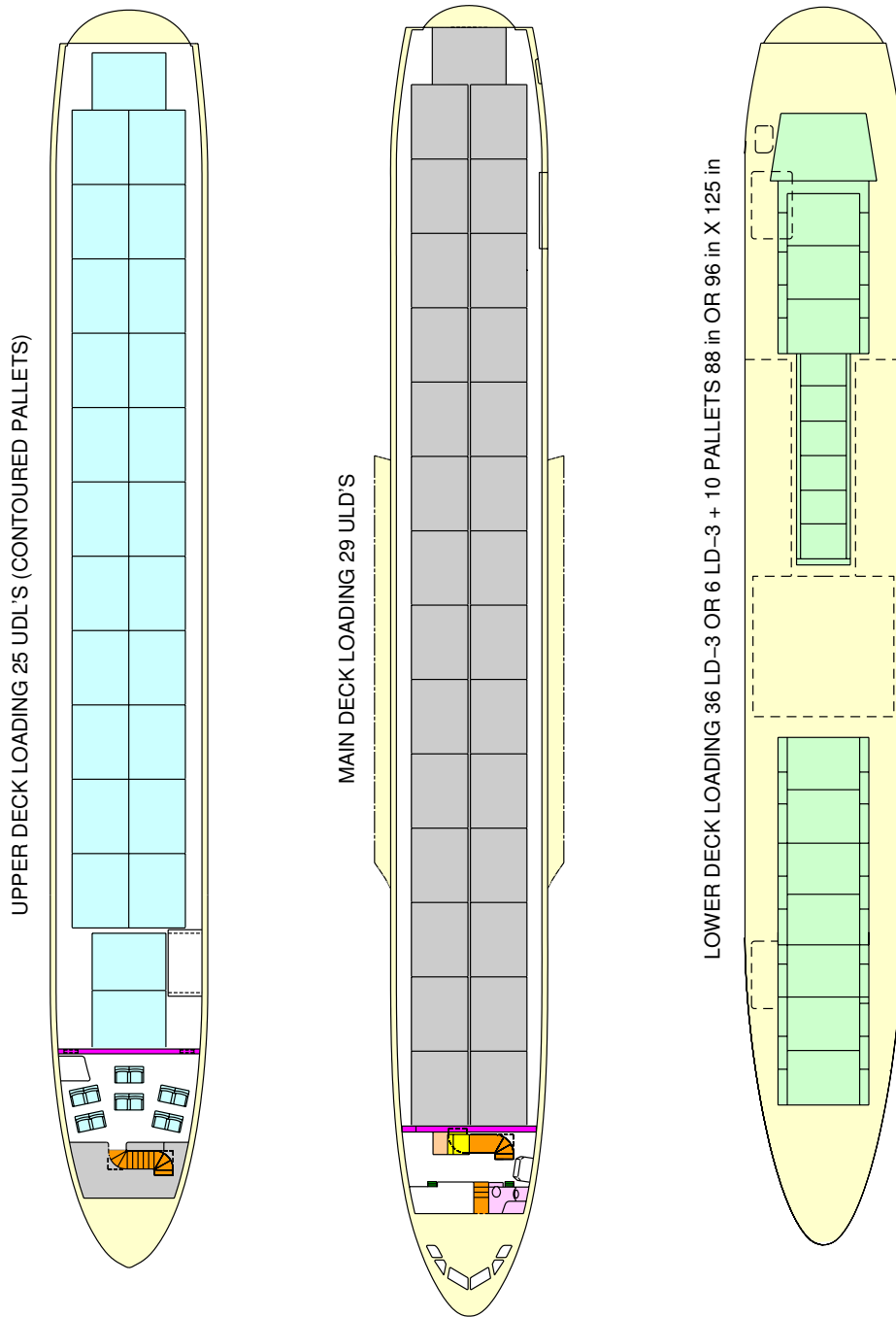

L_AC_020602_1_0020101_01_00

Cargo Compartments
Loading Combinations (Sheet 1)

**ON A/C A380-800F Models

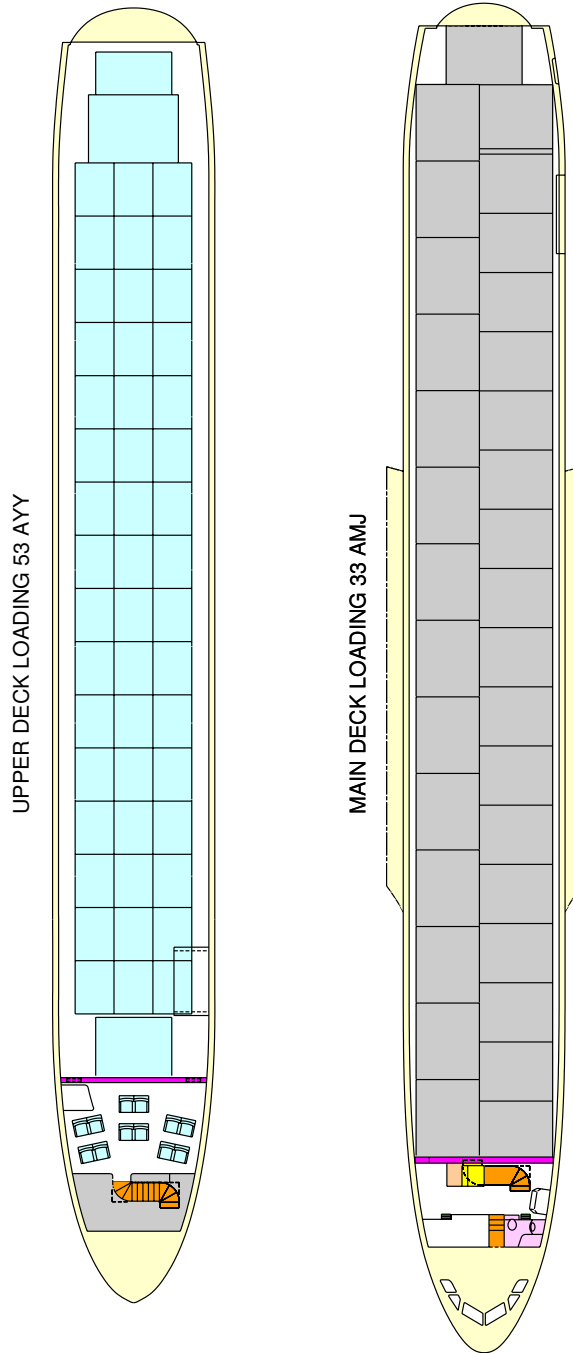

L_AC_020602_1_0030101_01_00

Cargo Compartments
Loading Combinations (Sheet 2)



AIRPLANE CHARACTERISTICS

2-7-0 Door Clearances

****ON A/C A380-800 Models**

Door Clearances - Pax

1. This section gives Door Clearances.

**ON A/C A380-800 Models

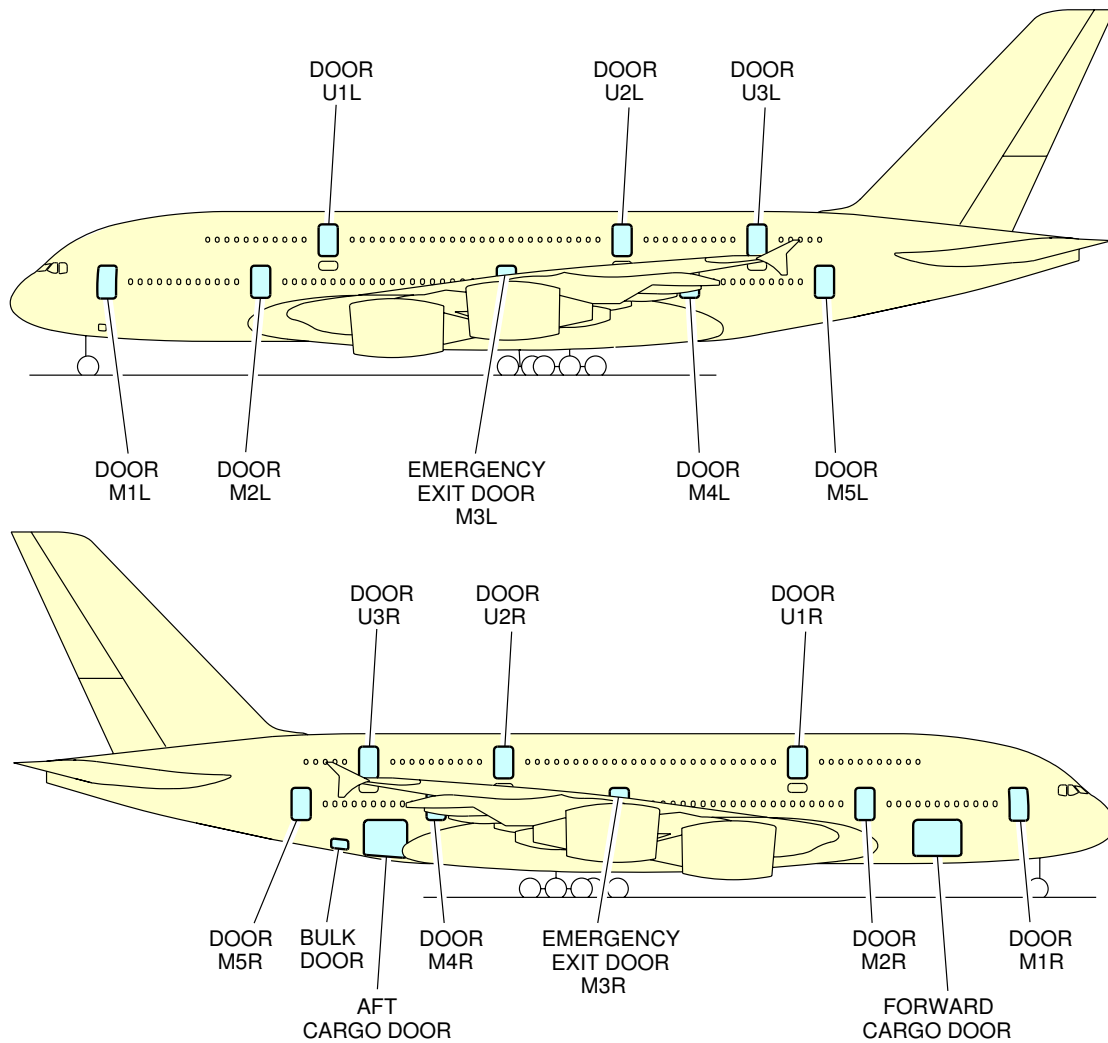

L_AC_020700_1_0010101_01_00

Door Clearances
Door Location (Sheet 1) - A380-800 Models

**ON A/C A380-800 Models

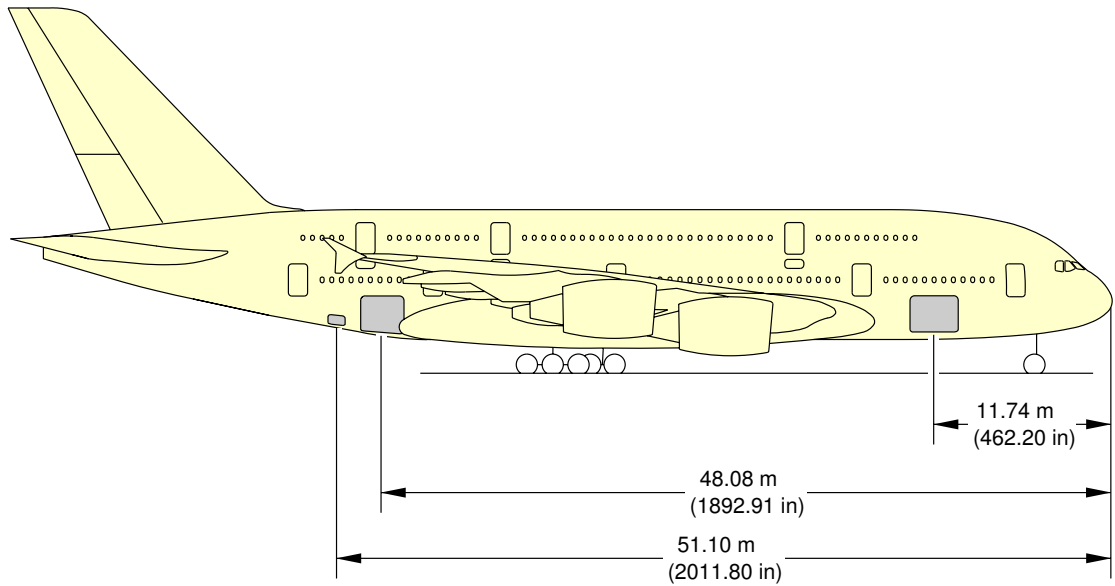
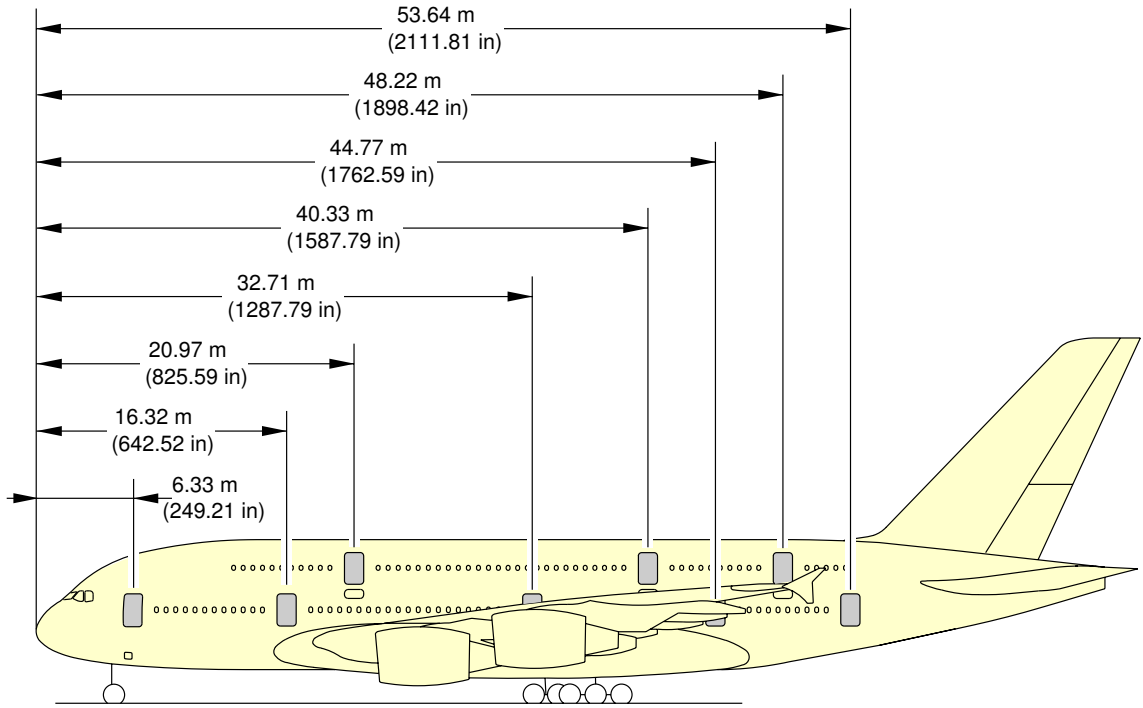

L_AC_020700_1_0020101_01_00

Door Clearances
Door Location (Sheet 2) - A380-800 Models



AIRPLANE CHARACTERISTICS

****ON A/C A380-800F Models**

Door Clearances - Freighter

1. This section gives door clearances.

****ON A/C A380-800F Models**

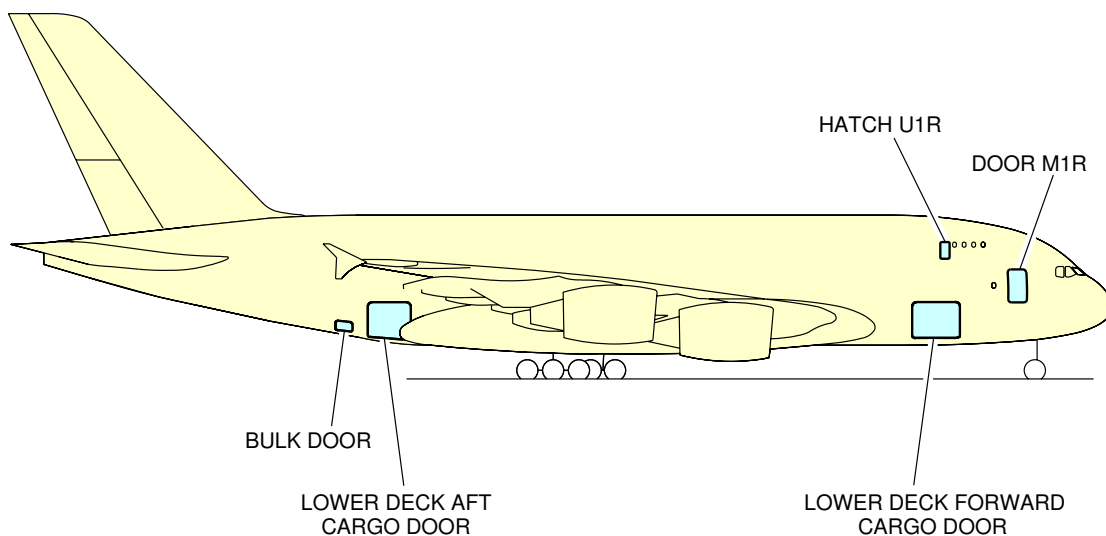
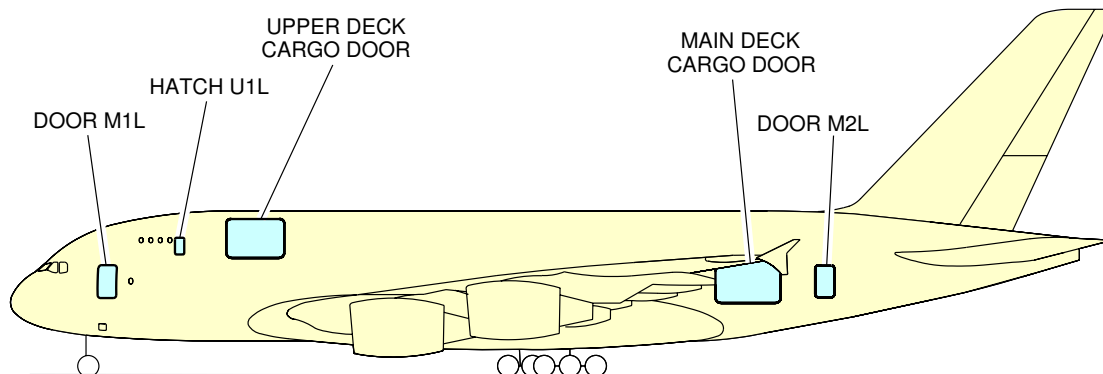

L_AC_020700_1_0030101_01_00

Door Clearances
Door Location (Sheet 1) - A380-800F Models

**ON A/C A380-800F Models

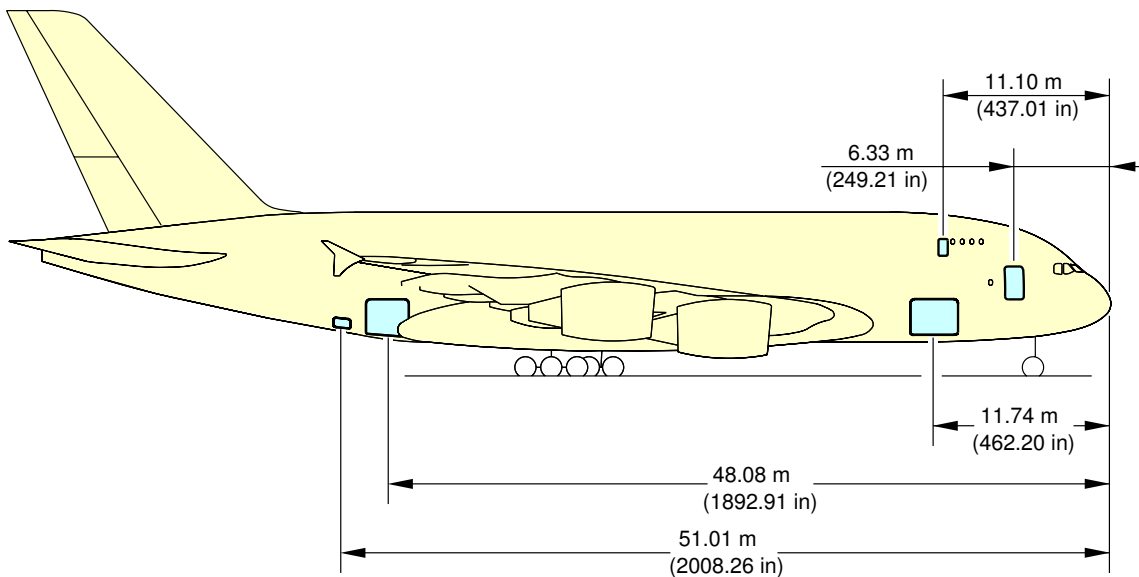
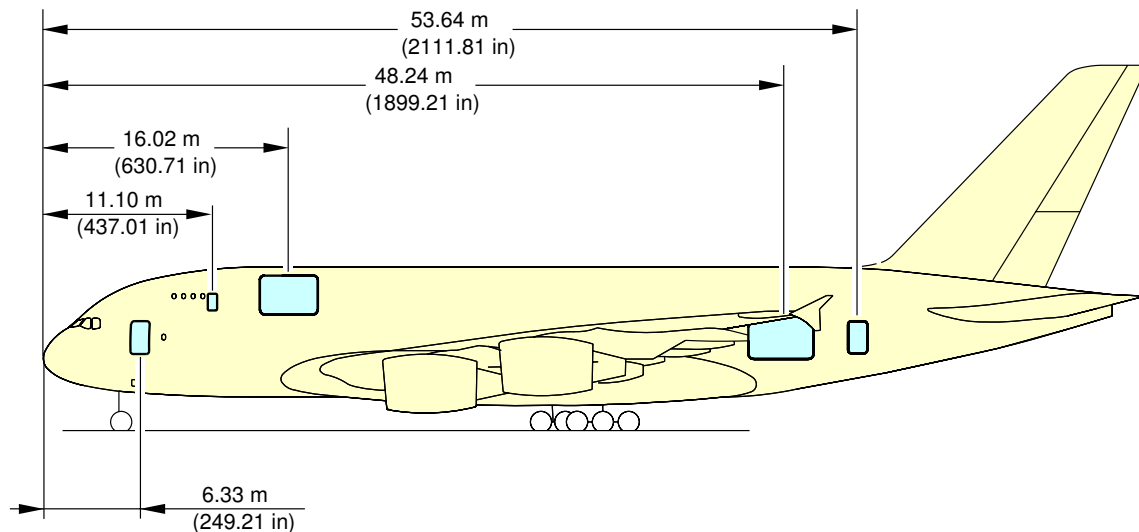

L_AC_020700_1_0040101_01_00

Door Clearances
Door Location (Sheet 2) - A380-800F Models



AIRPLANE CHARACTERISTICS

2-7-1 Forward Doors

****ON A/C A380-800 Models A380-800F Models**

Forward Doors

1. This section gives forward doors clearances.

**ON A/C A380-800 Models A380-800F Models

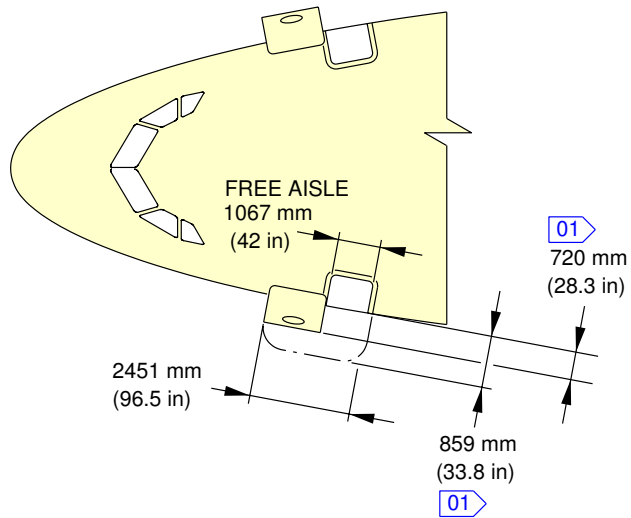
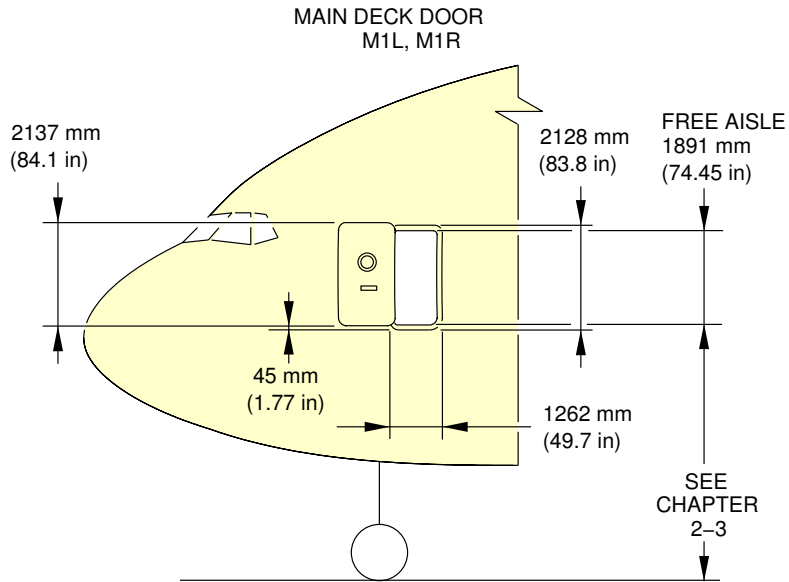

NOTE:

01 MEASURED FROM THE EXTERNAL POINT OF THE SCUFF PLATE AND THE MOST EXTERNAL POINT OF THE DOOR SKIN

L_AC_020701_1_0010101_01_00

Door Clearances
Forward Doors



AIRPLANE CHARACTERISTICS

2-7-2 Main and Upper Deck Doors

****ON A/C A380-800 Models**

Main and Upper Deck Doors - Pax

1. This section gives main and upper deck doors clearances.

****ON A/C A380-800 Models**

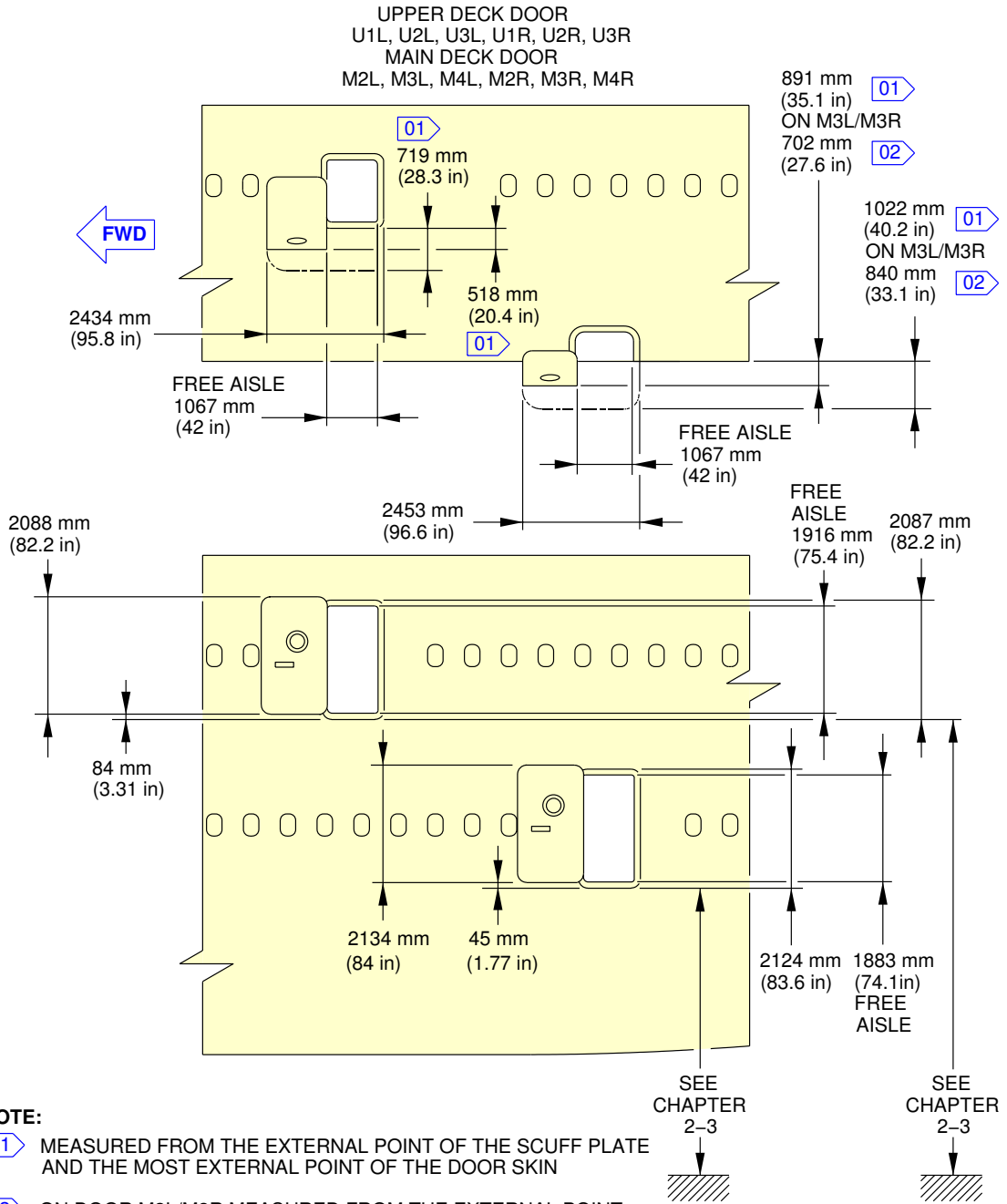

L_AC_020702_1_0010101_01_00

Door Clearances
Main and Upper Deck Doors - A380-800 Models



AIRPLANE CHARACTERISTICS

****ON A/C A380-800F Models**

Upper Deck Door - Freighter

1. This section gives upper deck door clearances.

****ON A/C A380-800F Models**

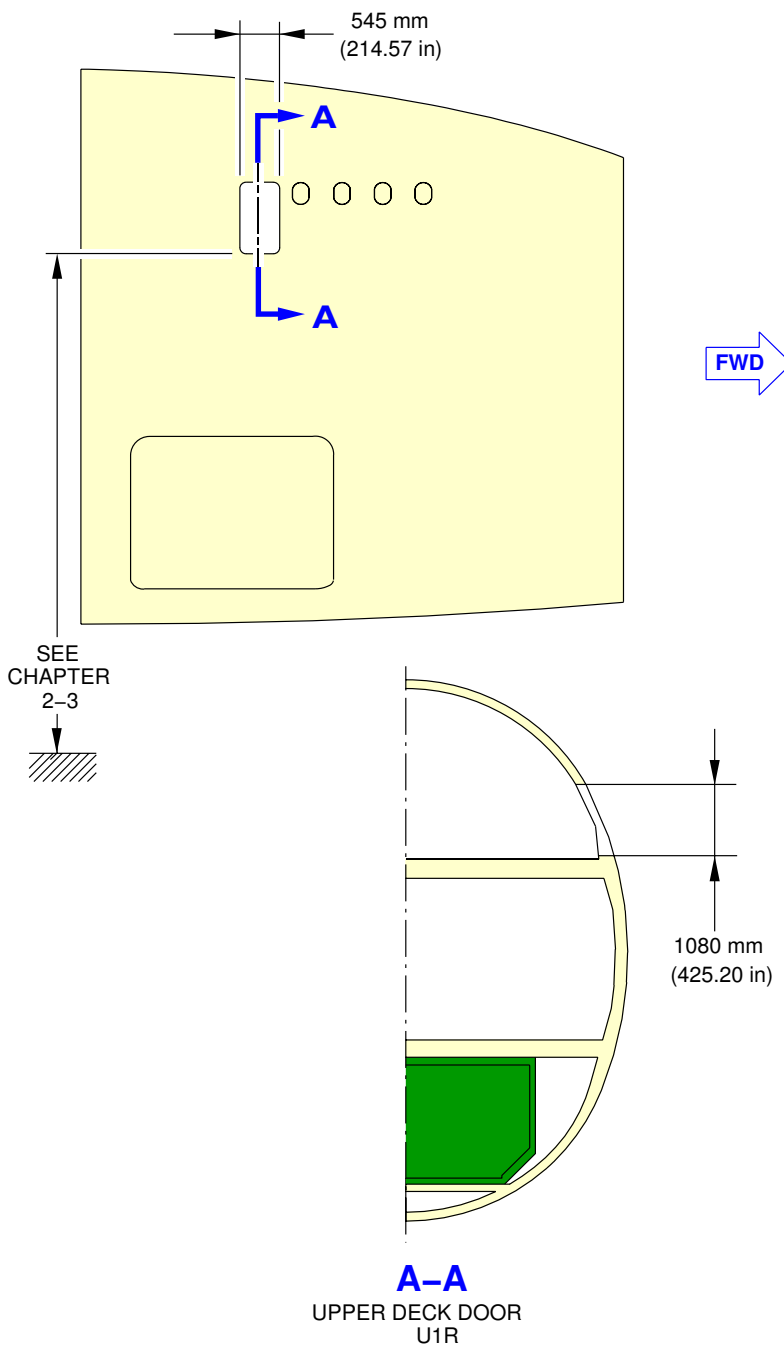

L_AC_020702_1_0020101_01_00

Door Clearances
Upper Deck Door - A380-800F Models



AIRPLANE CHARACTERISTICS

2-7-3 Aft Doors

****ON A/C A380-800 Models**

Aft Doors - Pax

1. This section gives aft doors clearances.

**ON A/C A380-800 Models

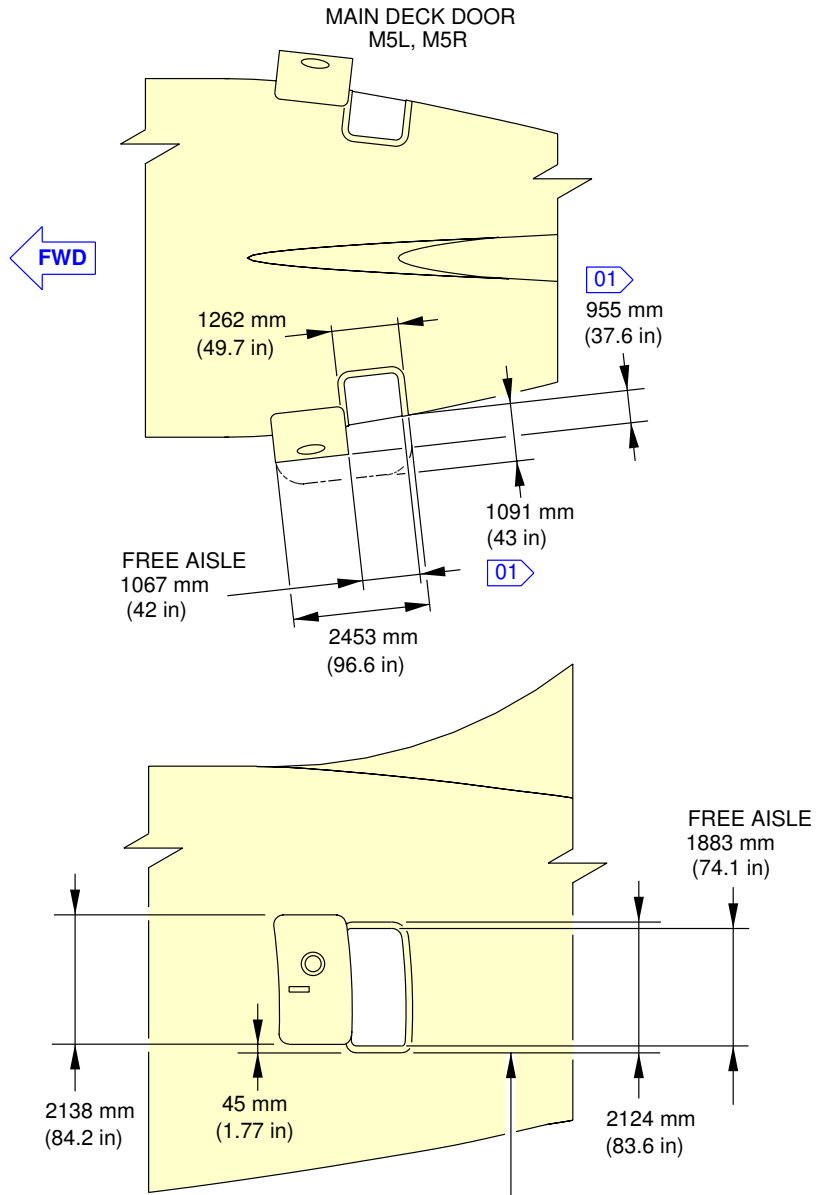

NOTE:

01 MEASURED FROM THE EXTERNAL POINT OF THE SCUFF PLATE AND THE MOST EXTERNAL POINT OF THE DOOR SKIN

L_AC_020703_1_0010101_01_00

Door Clearances
Aft Doors - A380-800 Models



AIRPLANE CHARACTERISTICS

****ON A/C A380-800F Models**

Aft Doors - Freighter

1. This section gives aft doors clearances.

****ON A/C A380-800F Models**

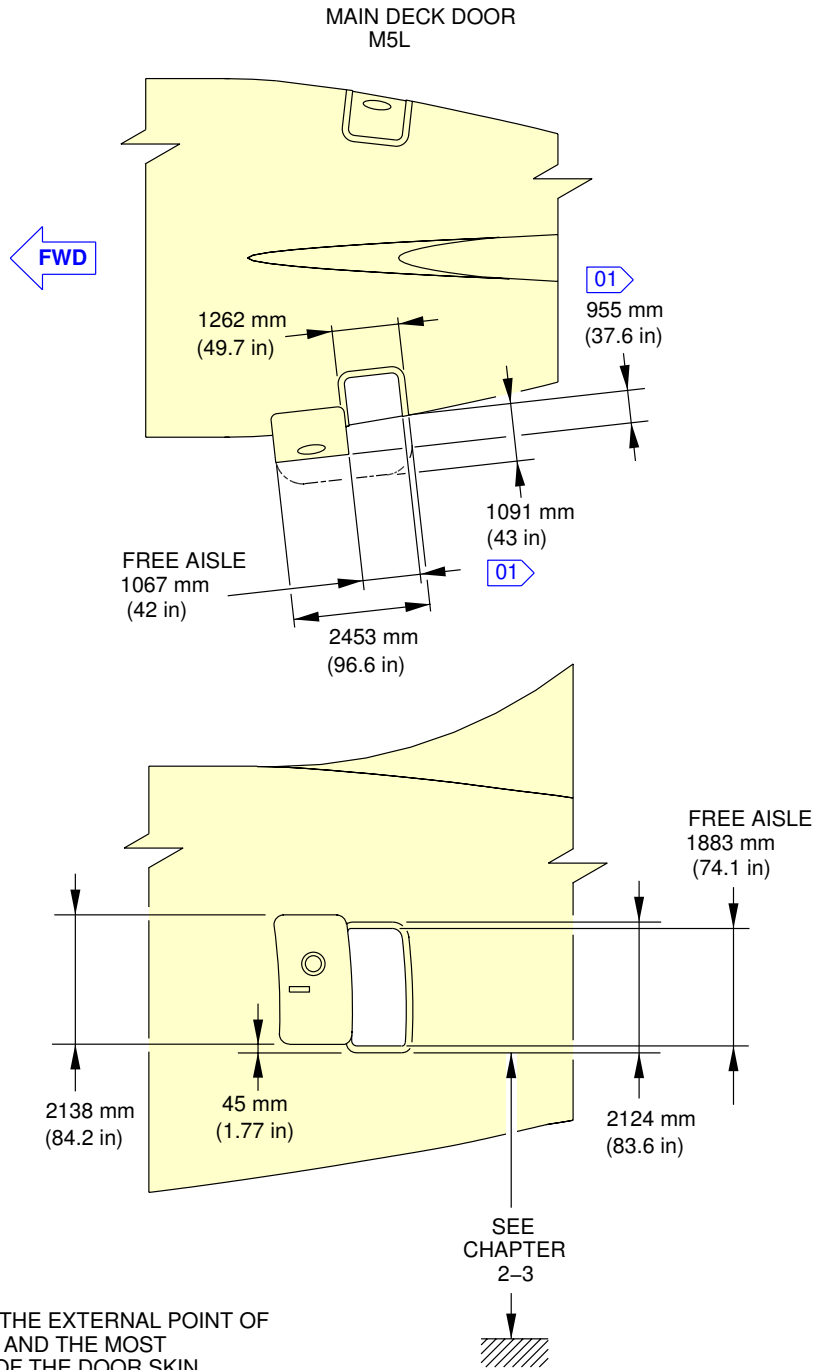

NOTE:
 01 MEASURED FROM THE EXTERNAL POINT OF THE SCUFF PLATE AND THE MOST EXTERNAL POINT OF THE DOOR SKIN

L_AC_020703_1_0020101_01_00

Door Clearances
Aft Doors - A380-800F Models



AIRPLANE CHARACTERISTICS

2-7-4 Aft Cargo Compartment Doors

****ON A/C A380-800 Models**

Aft Cargo Compartment Doors - Pax

1. This section gives aft cargo compartment doors clearances.

****ON A/C A380-800 Models**

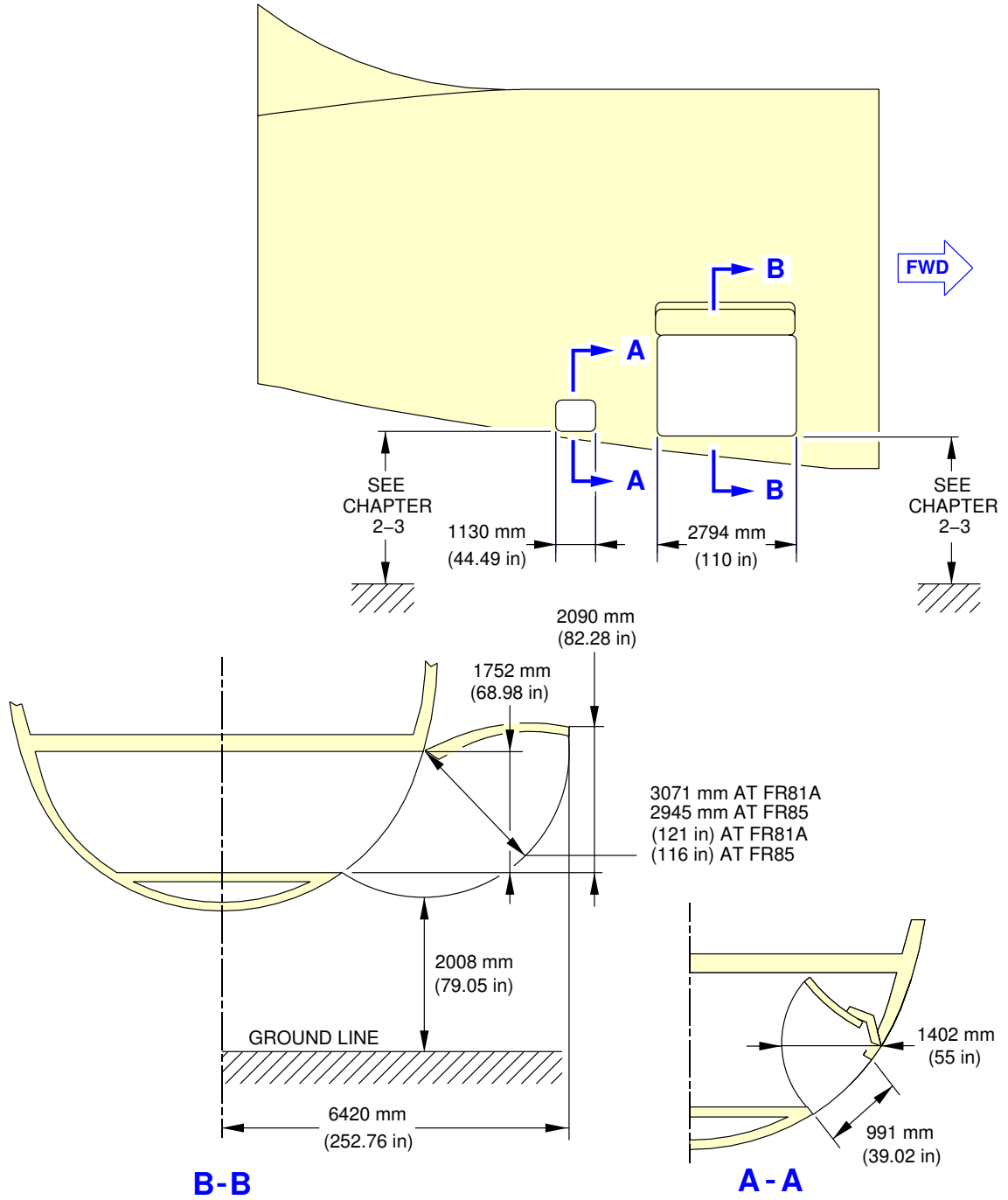

L_AC_020704_1_0010101_01_01

Door Clearances
Aft Cargo Compartment Doors - A380-800 Models



AIRPLANE CHARACTERISTICS

****ON A/C A380-800F Models**

Aft Cargo Compartment Doors - Freighter

1. This section gives aft cargo compartment doors clearances.

**ON A/C A380-800F Models

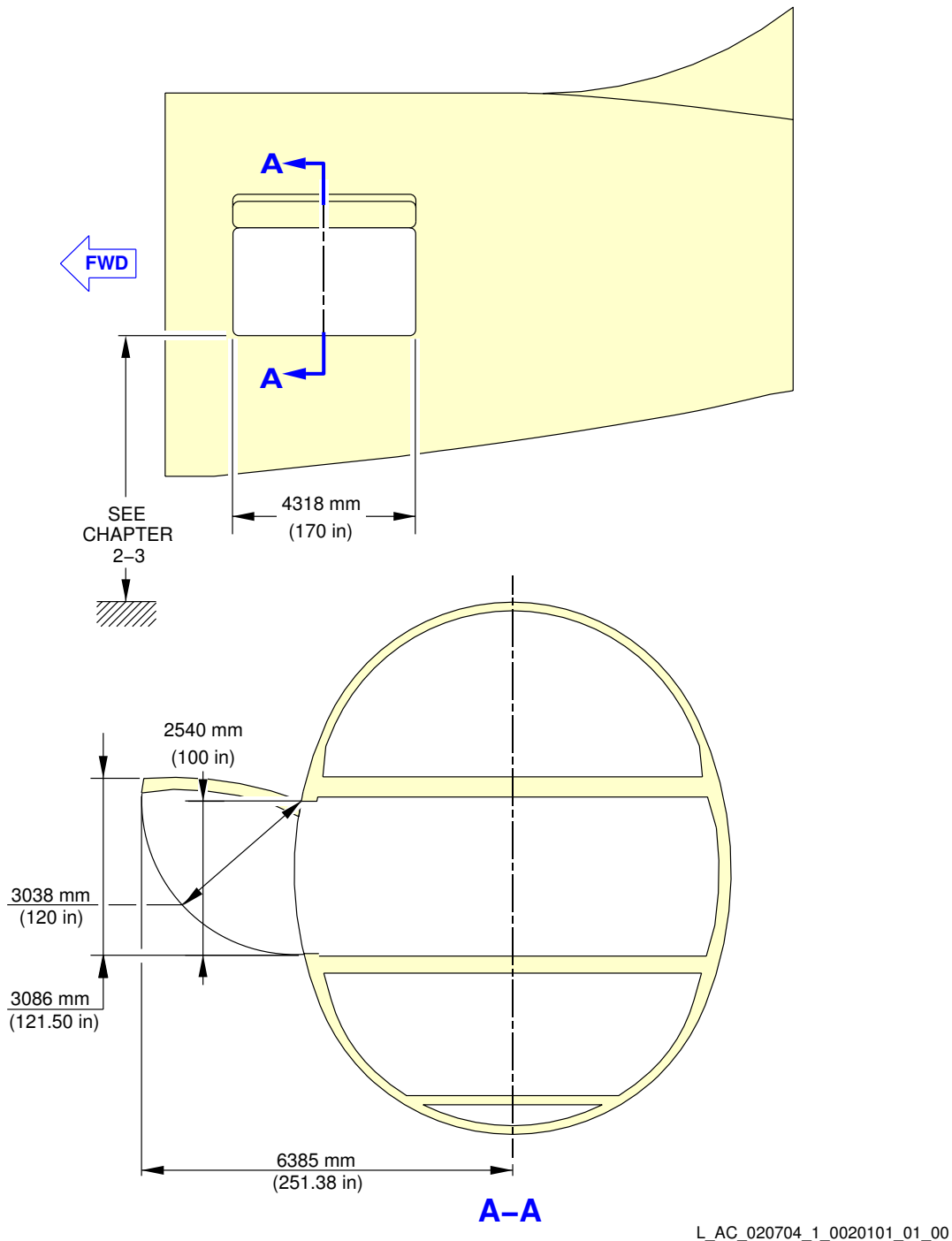

L_AC_020704_1_0020101_01_00

Door Clearances
Main Deck Cargo Door - A380-800F Models

****ON A/C A380-800F Models**

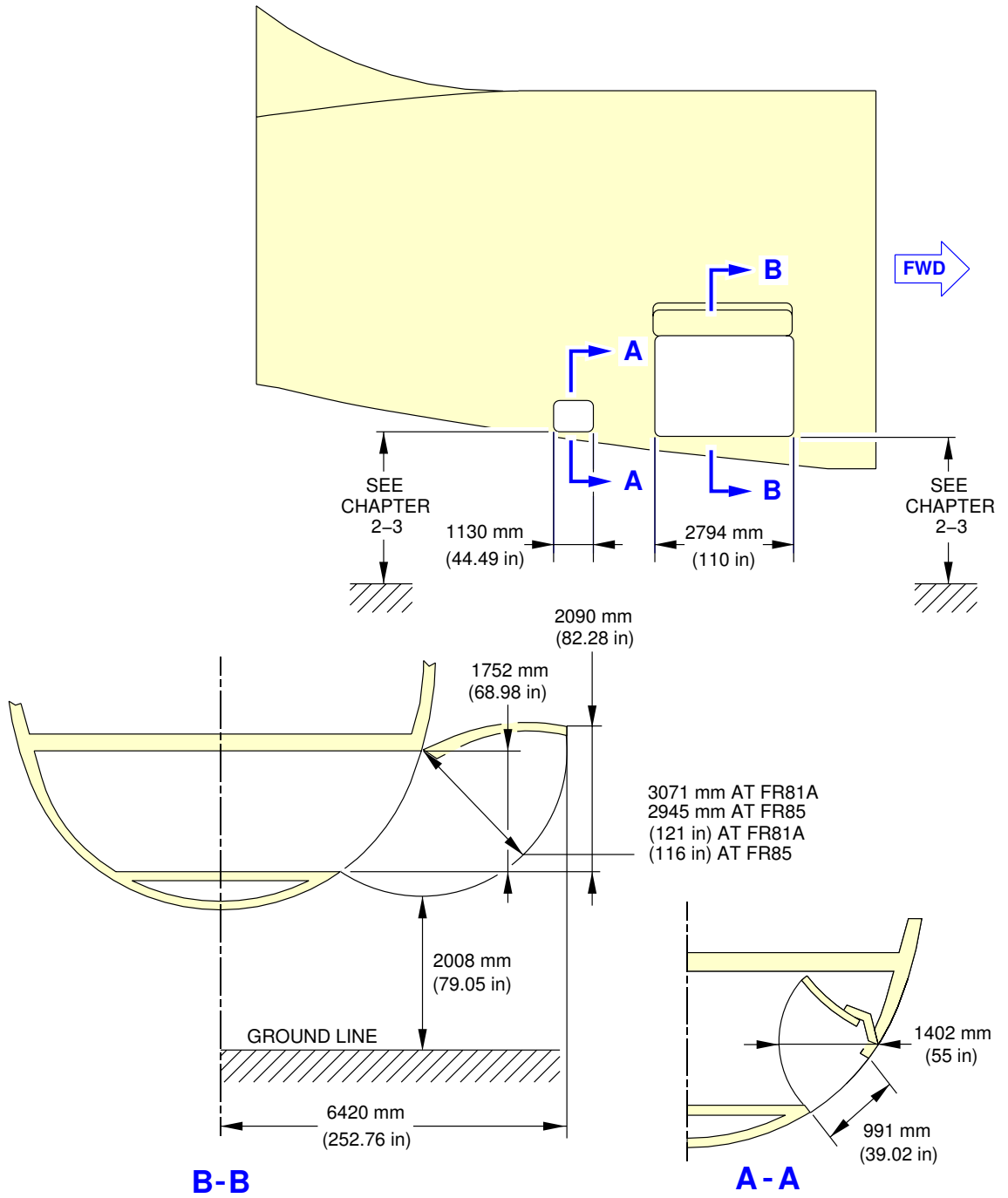

L_AC_020704_1_0030101_01_01

Door Clearances
Lower Deck Aft Cargo Doors - A380-800F Models



AIRPLANE CHARACTERISTICS

2-7-5 Forward Cargo Compartment Doors

****ON A/C A380-800 Models**

Forward Cargo Compartment Doors - Pax

1. This section gives forward cargo compartment doors clearances.

**ON A/C A380-800 Models

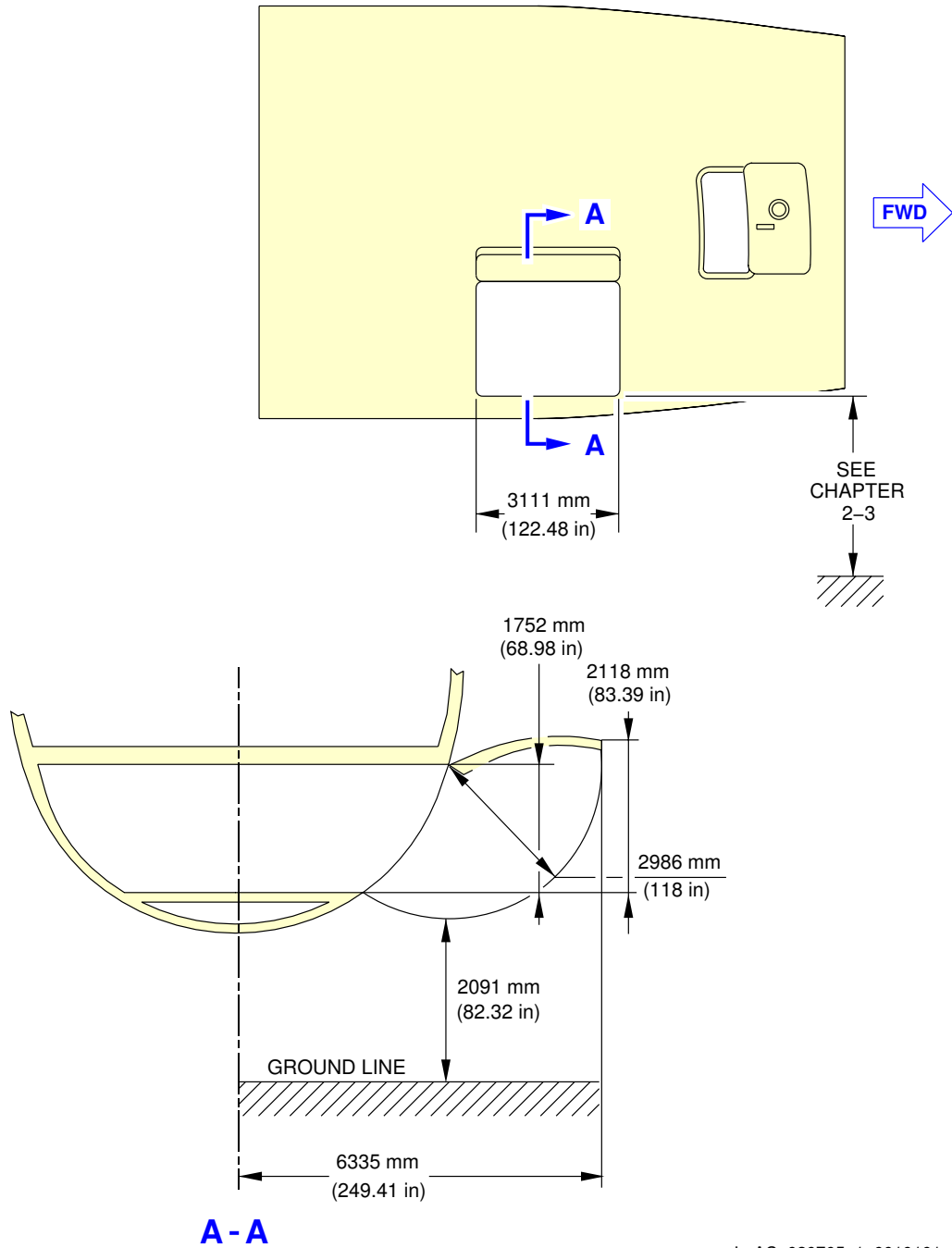

L_AC_020705_1_0010101_01_01

Door Clearances
Forward Cargo Compartment Doors - A380-800 Models



AIRPLANE CHARACTERISTICS

****ON A/C A380-800F Models**

Forward Cargo Compartment Doors - Freighter

1. This section gives forward cargo compartment doors clearances.

**ON A/C A380-800F Models

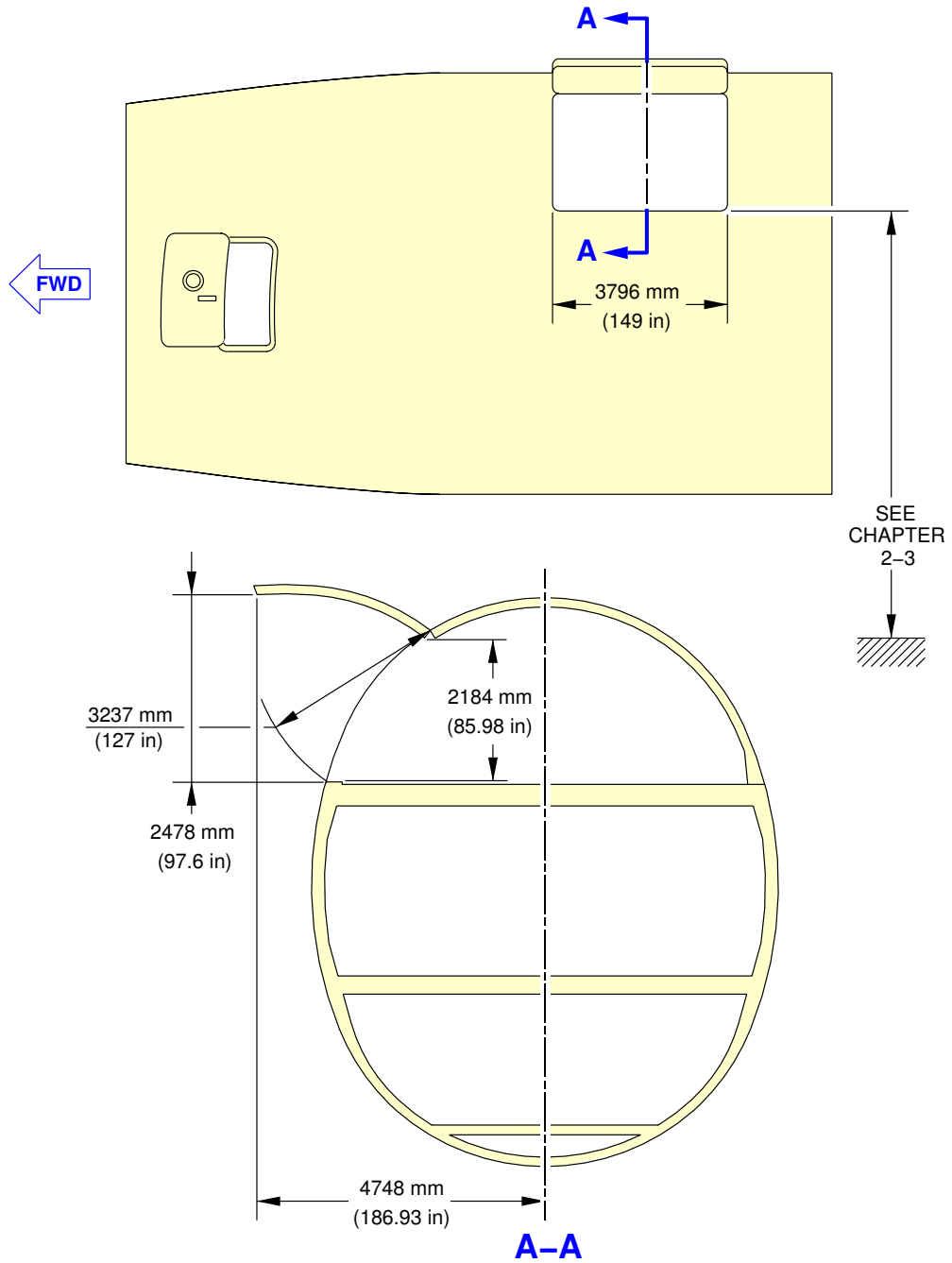

L_AC_020705_1_0020101_01_01

Door Clearances
Upper Deck Cargo Door - A380-800F Models

**ON A/C A380-800F Models

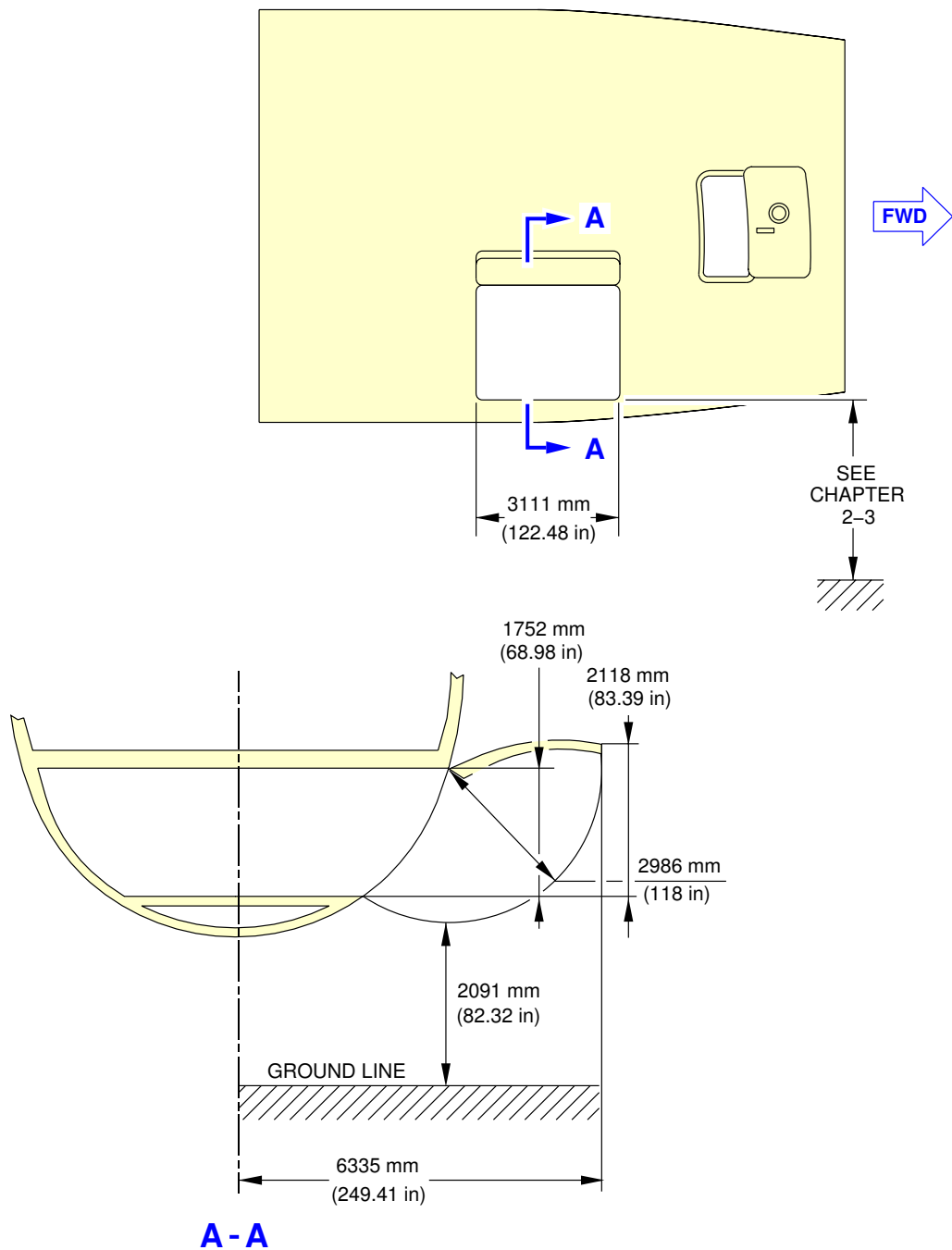

L_AC_020705_1_0030101_01_01

Door Clearances
Lower Deck Forward Cargo Door - A380-800F Models



AIRPLANE CHARACTERISTICS

2-7-6 Nose Landing Gear Doors

****ON A/C A380-800 Models A380-800F Models**

Nose Landing Gear Doors

1. This section gives nose landing gear doors clearances.

**ON A/C A380-800 Models A380-800F Models

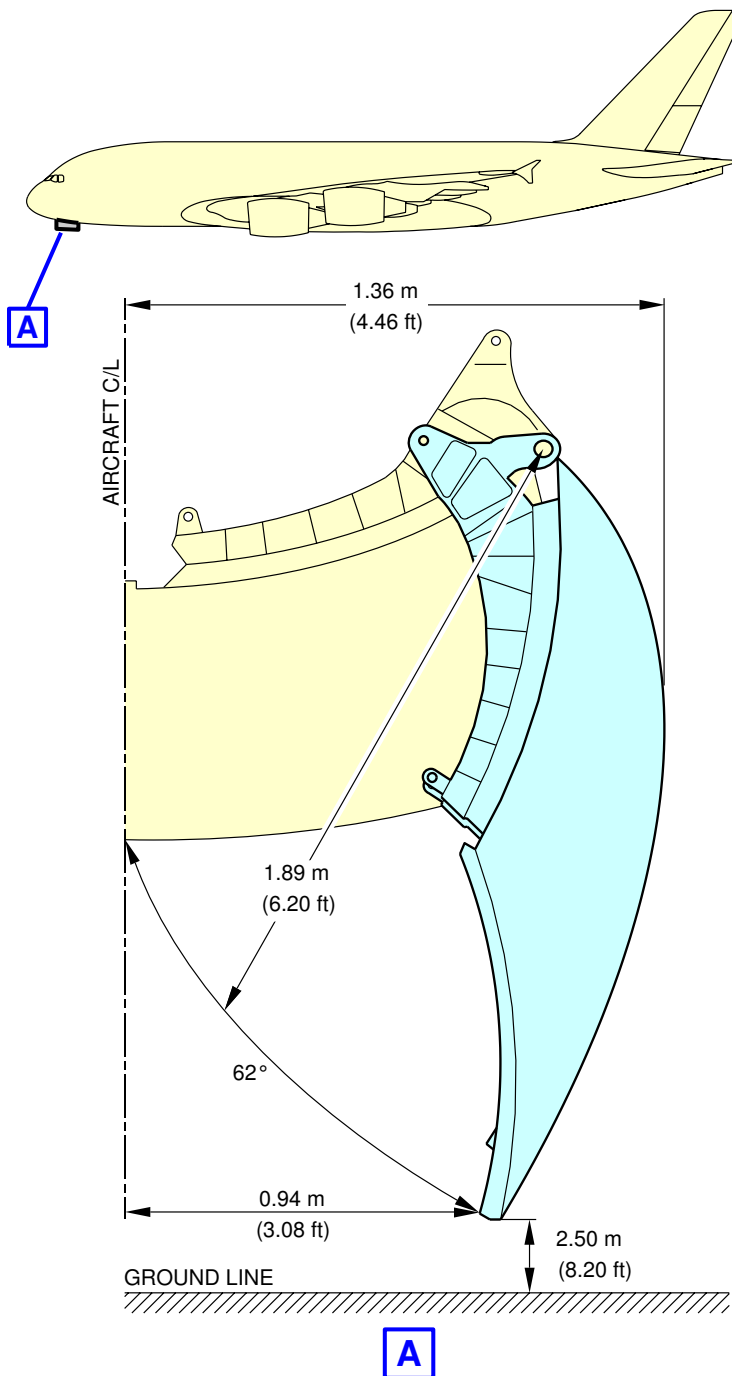

L_AC_020706_1_0010101_01_00

Door Clearances
Forward Nose Landing Gear Doors

**ON A/C A380-800 Models A380-800F Models

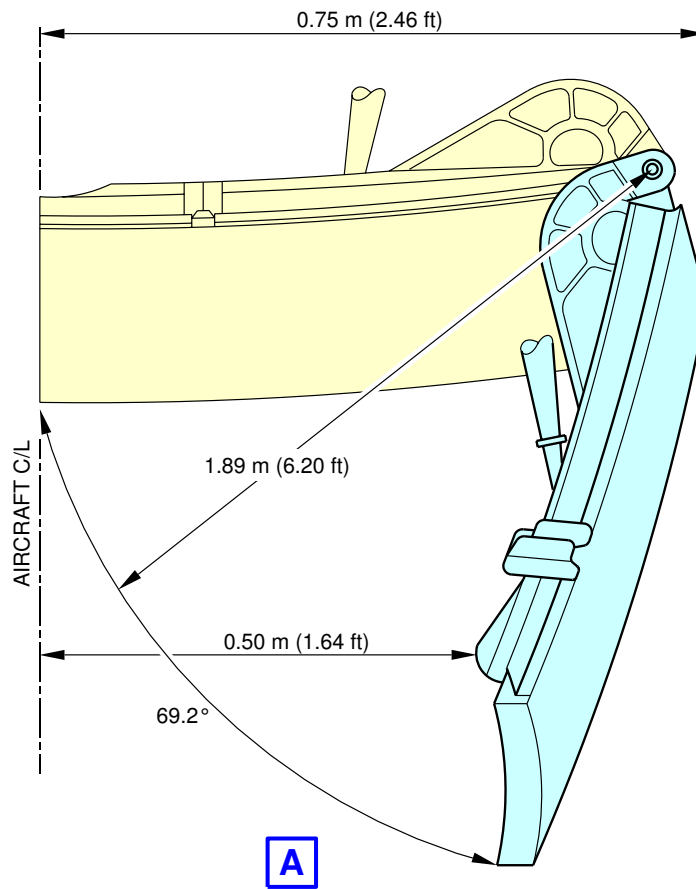
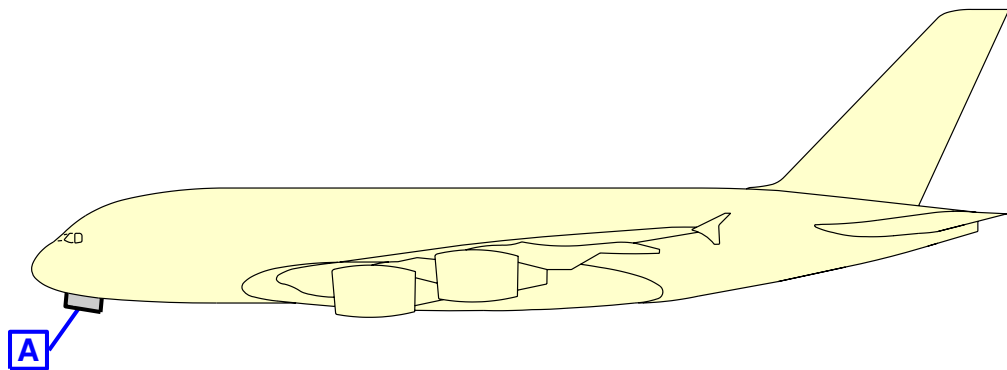

L_AC_020706_1_0020101_01_00

Door Clearances
Aft Nose Landing Gear Doors



AIRPLANE CHARACTERISTICS

2-7-7 Wing Landing Gear Doors

**ON A/C A380-800 Models A380-800F Models

Wing Landing Gear Doors

1. This section gives wing landing gear doors clearances.

**ON A/C A380-800 Models A380-800F Models

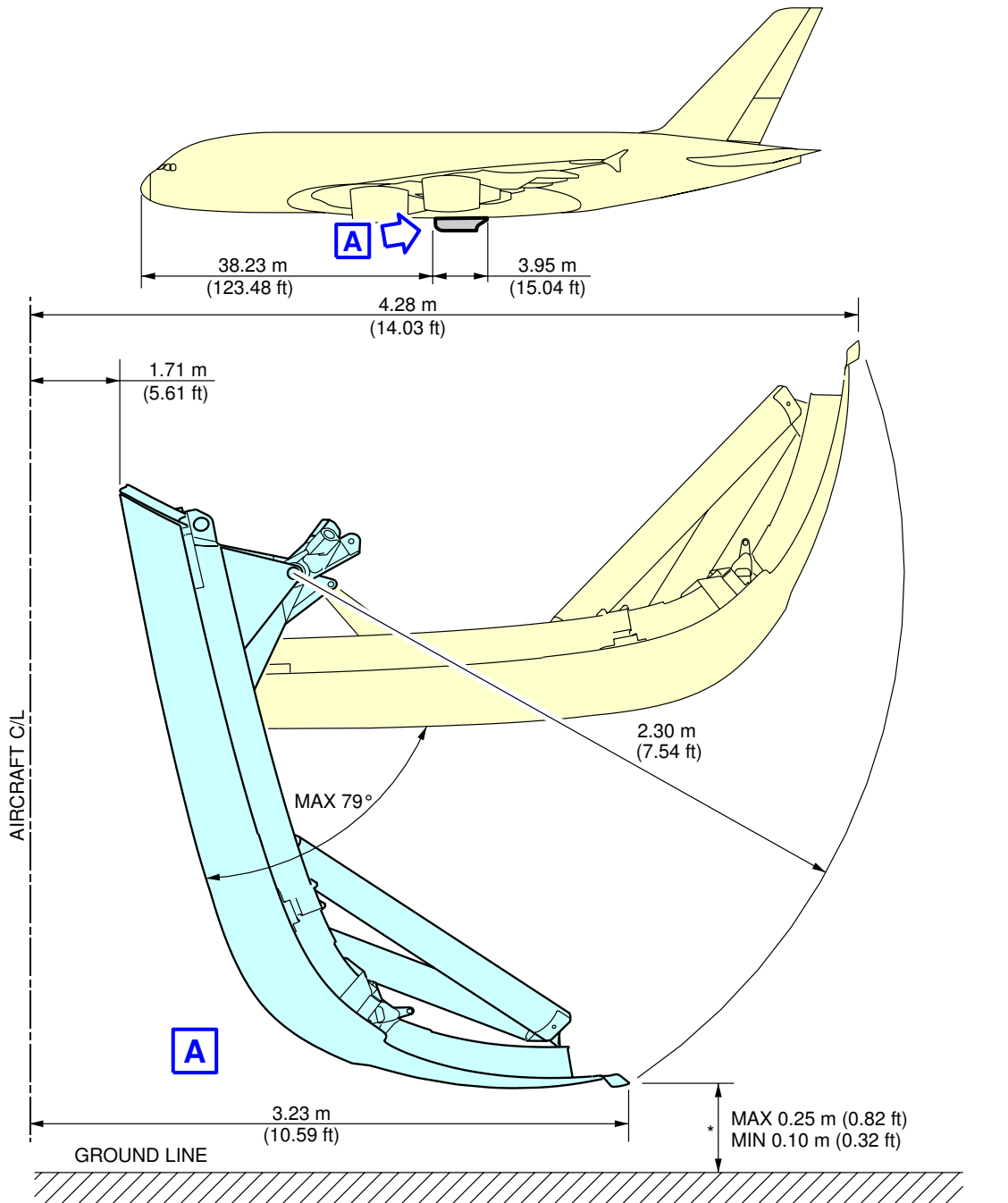

* DEPENDING ON CG POSITION AND AIRCRAFT WEIGHT

L_AC_020707_1_0010101_01_00

Door Clearances
Wing Landing Gear Doors



AIRPLANE CHARACTERISTICS

2-7-8 Body Landing Gear Doors

****ON A/C A380-800 Models A380-800F Models**

Body Landing Gear Doors

1. This section gives body landing gear doors clearances.

**ON A/C A380-800 Models A380-800F Models

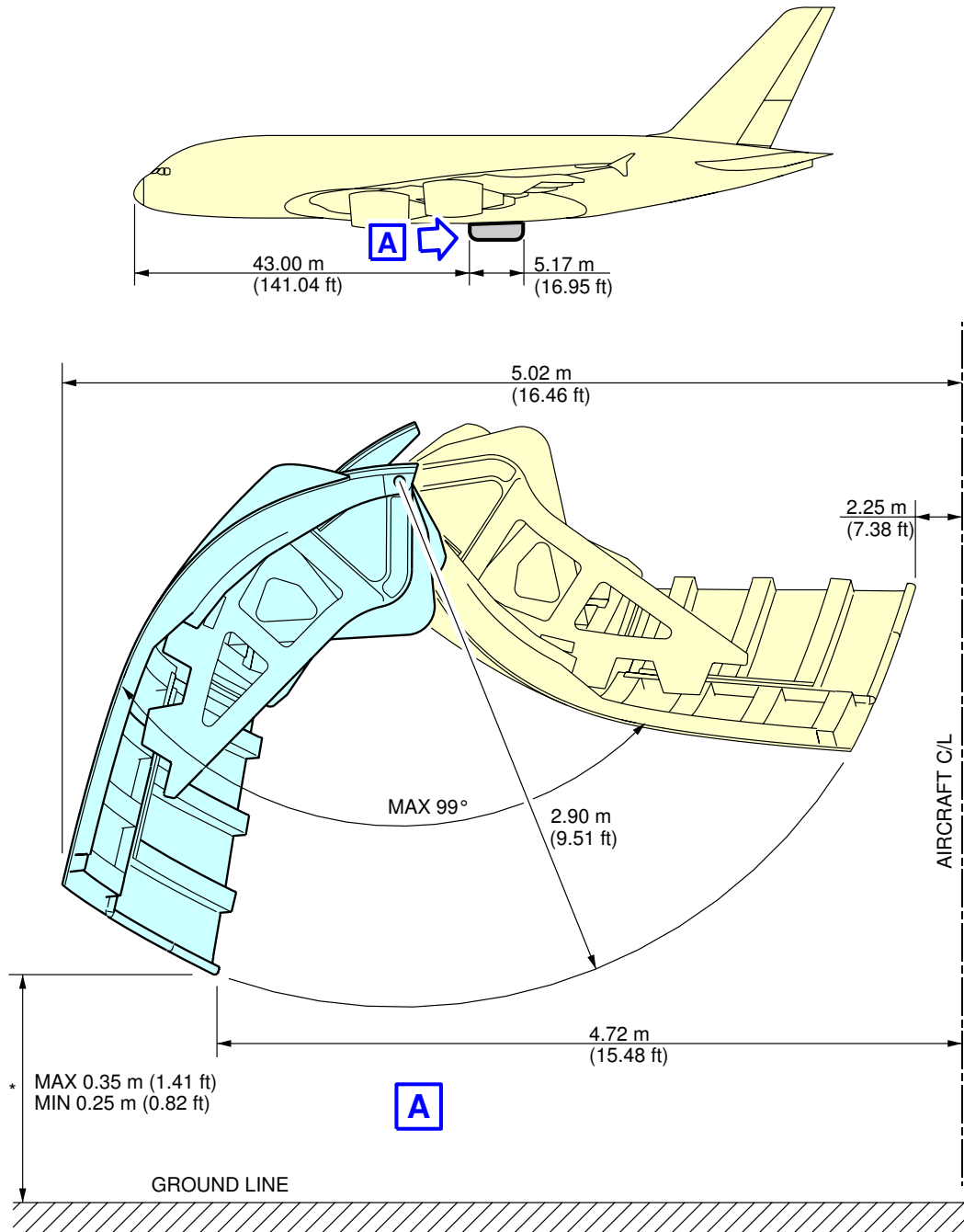

* DEPENDING ON CG POSITION AND AIRCRAFT WEIGHT

L_AC_020708_1_0010101_01_00

Door Clearances Body Landing Gear Doors (Sheet 1)

**ON A/C A380-800 Models A380-800F Models

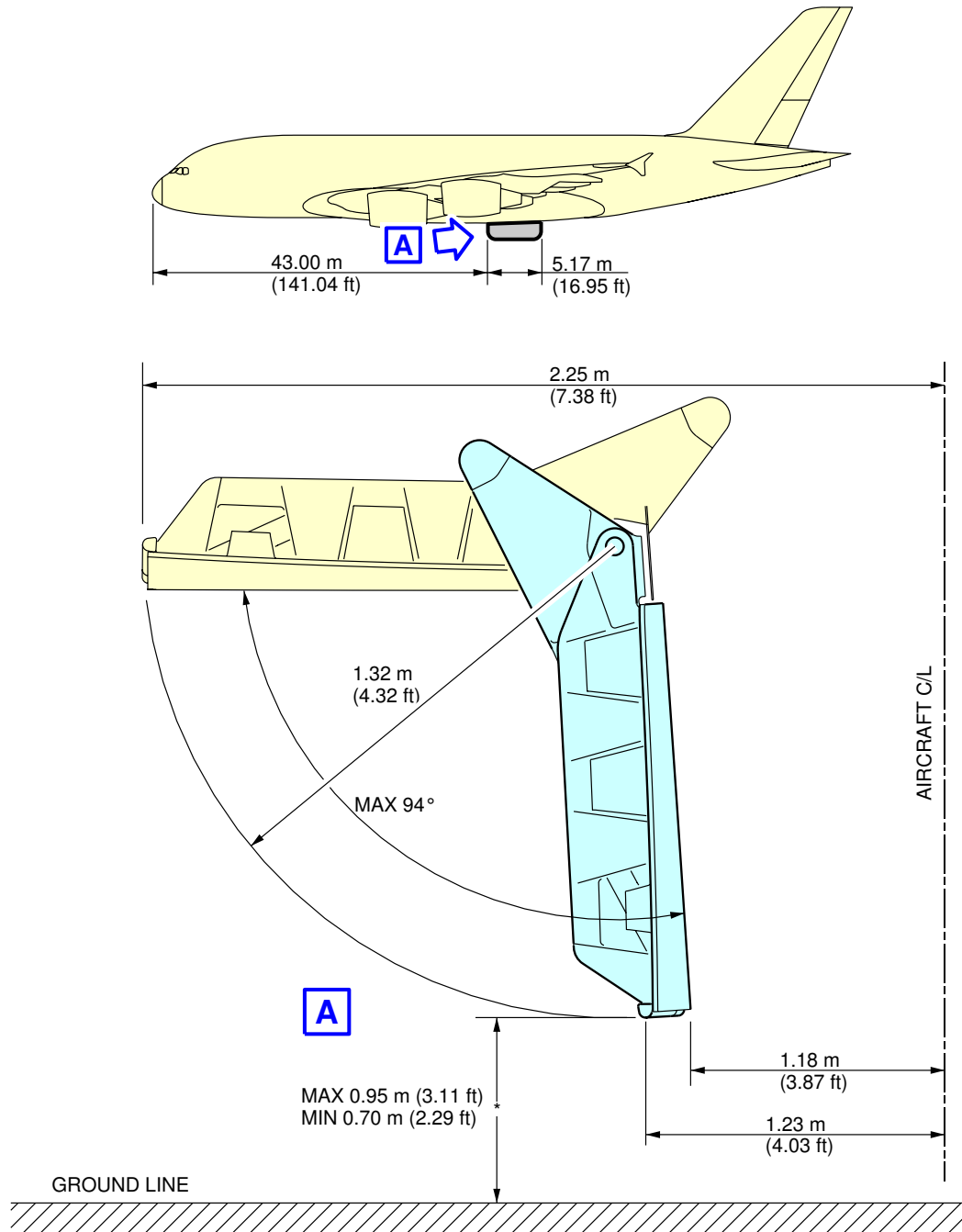

* DEPENDING ON CG POSITION AND AIRCRAFT WEIGHT L_AC_020708_1_0020101_01_00

Door Clearances Body Landing Gear Doors (Sheet 2)



AIRPLANE CHARACTERISTICS

2-7-9 APU Doors

****ON A/C A380-800 Models A380-800F Models**

APU Doors

1. This section gives APU doors clearances.

**ON A/C A380-800 Models A380-800F Models

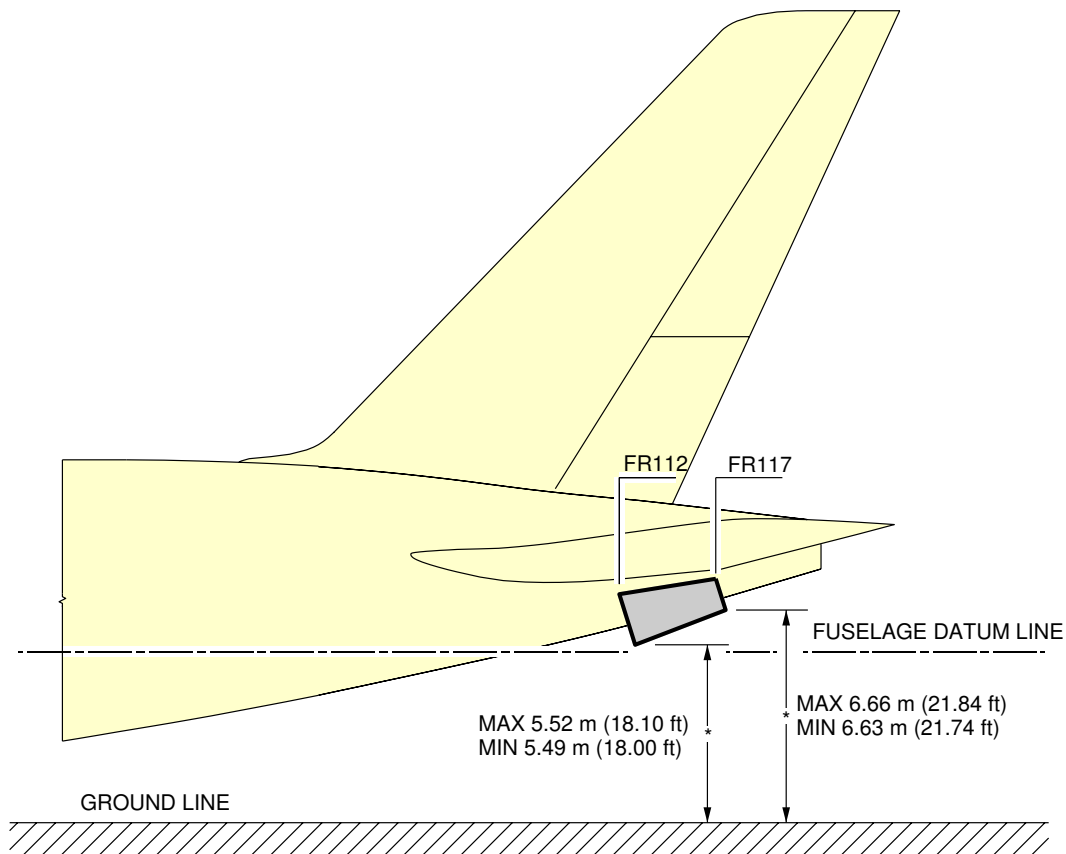

* DEPENDING ON CG POSITION AND AIRCRAFT WEIGHT

L_AC_020709_1_0010101_01_00

Door Clearances
APU Doors



AIRPLANE CHARACTERISTICS

AIRPLANE PERFORMANCE

3-1-0 General Information

**ON A/C A380-800 Models A380-800F Models

General Information

1. Standard day temperatures for the altitudes shown are tabulated below :

Standard day temperatures for the altitudes			
Altitude		Standard Day Temperature	
FEET	METERS	° F	° C
0	0	59.0	15.0
2000	610	51.9	11.6
4000	1220	44.7	7.1
6000	1830	37.6	3.1
8000	2440	30.5	-0.8



AIRPLANE CHARACTERISTICS

3-2-0 Payload / Range

**ON A/C A380-800 Models A380-800F Models

Payload /Range

1. Payload / Range



AIRPLANE CHARACTERISTICS

3-2-1 ISA Conditions

****ON A/C A380-800 Models**

Payload/Range - Pax

1. This section gives the payload/range at ISA conditions.

****ON A/C A380-800 Models**

NOTE: THESE CURVES ARE GIVEN FOR INFORMATION ONLY.
THE APPROVED VALUES ARE STATED IN THE "OPERATING MANUALS"
SPECIFIC TO THE AIRLINE OPERATING THE AIRCRAFT.

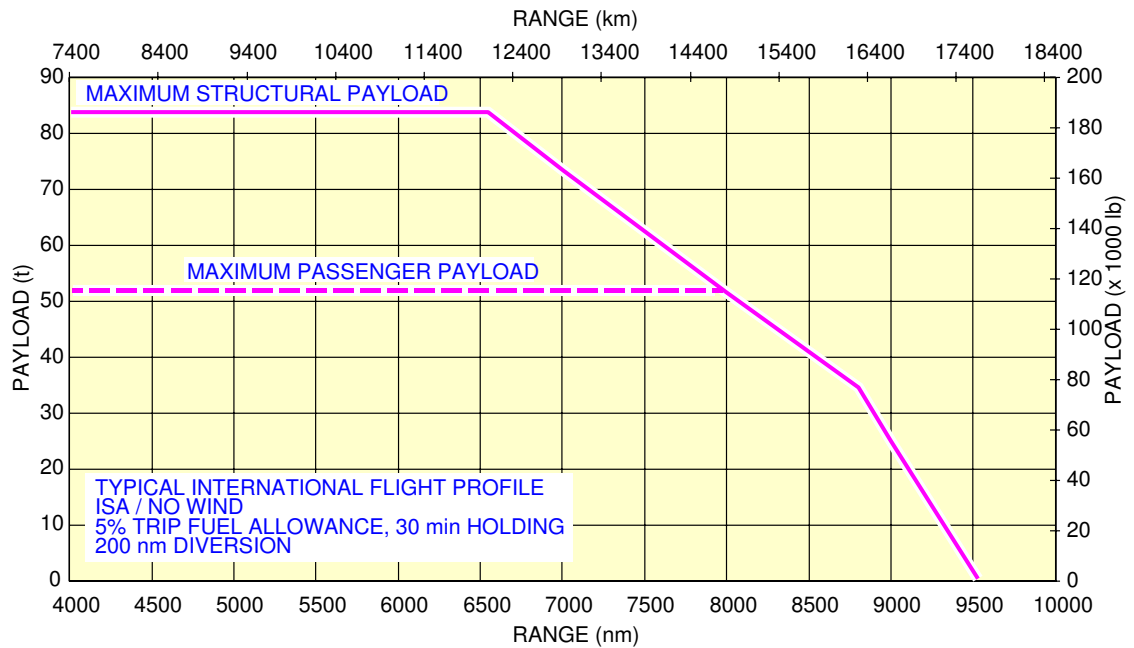

L_AC_030201_1_0010101_01_00

Payload/Range
ISA Conditions - TRENT 900 Engines

****ON A/C A380-800 Models**

NOTE: THESE CURVES ARE GIVEN FOR INFORMATION ONLY.
THE APPROVED VALUES ARE STATED IN THE "OPERATING MANUALS"
SPECIFIC TO THE AIRLINE OPERATING THE AIRCRAFT.

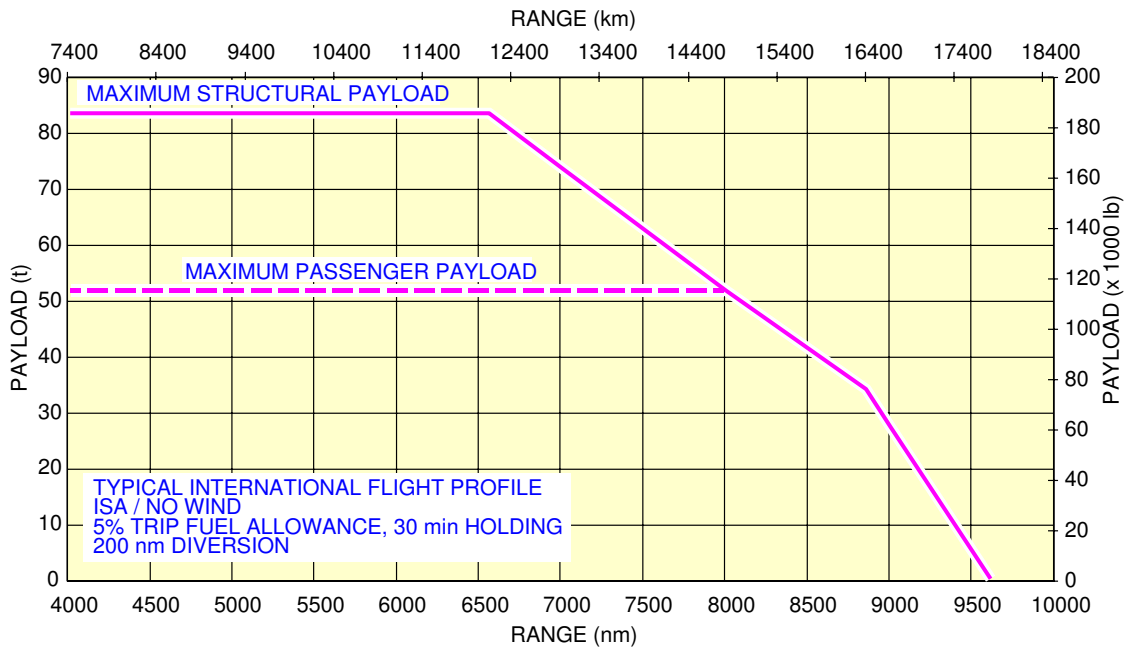

L_AC_030201_1_0080101_01_00

Payload/Range
ISA Conditions - GP 7200 Engines



AIRPLANE CHARACTERISTICS

****ON A/C A380-800F Models**

Payload/Range - Freighter

1. This section gives the payload/range at ISA conditions.

****ON A/C A380-800F Models**

NOTE: THESE CURVES ARE GIVEN FOR INFORMATION ONLY.
THE APPROVED VALUES ARE STATED IN THE "OPERATING MANUALS"
SPECIFIC TO THE AIRLINE OPERATING THE AIRCRAFT.

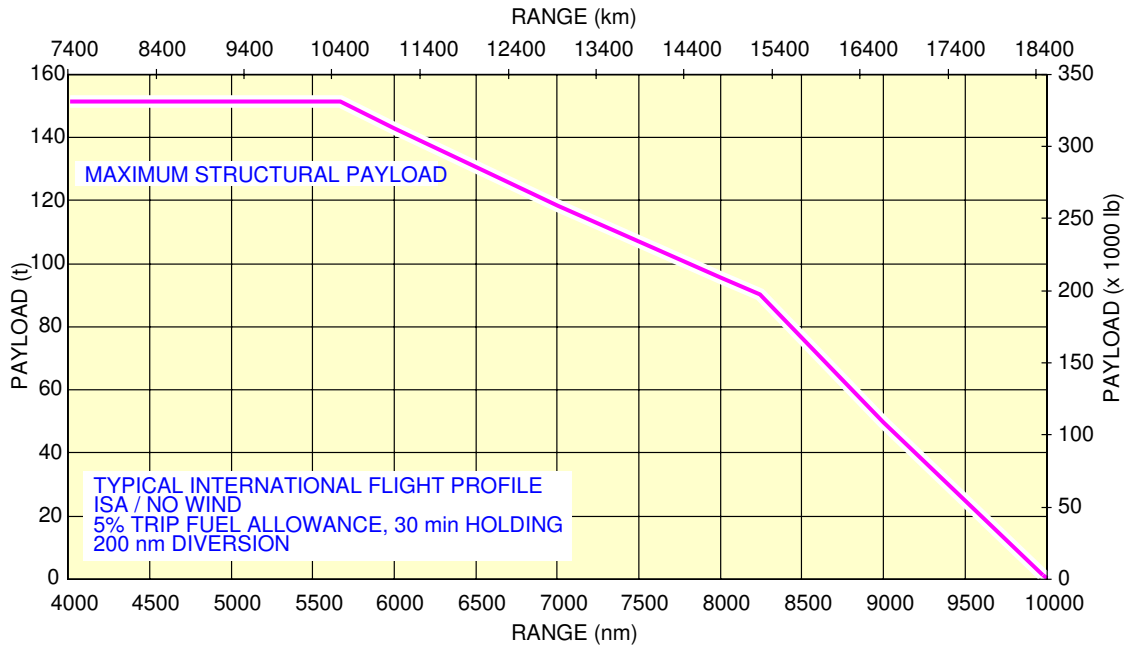

L_AC_030201_1_0060101_01_00

Payload/Range
ISA Conditions - TRENT 900 Engines



AIRPLANE CHARACTERISTICS

****ON A/C A380-800F Models**

NOTE: THESE CURVES ARE GIVEN FOR INFORMATION ONLY.
THE APPROVED VALUES ARE STATED IN THE "OPERATING MANUALS"
SPECIFIC TO THE AIRLINE OPERATING THE AIRCRAFT.

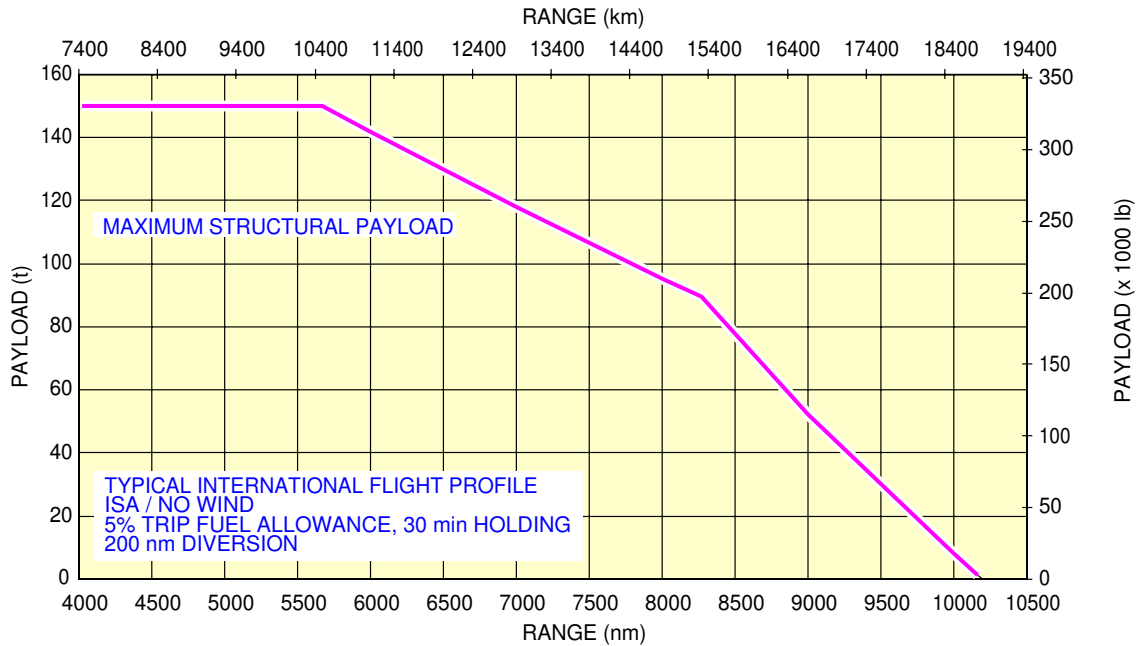

L_AC_030201_1_0090101_01_00

Payload/Range
ISA Conditions - GP 7200 Engines



AIRPLANE CHARACTERISTICS

3-3-0 Take Off Weight Limitation

**ON A/C A380-800 Models A380-800F Models

Take Off Weight Limitation

1. Take Off Weight Limitation



AIRPLANE CHARACTERISTICS

3-3-1 ISA Conditions

****ON A/C A380-800 Models**

Take Off Weight Limitation - Pax

1. This section gives the take-off weight limitation at ISA conditions.



AIRPLANE CHARACTERISTICS

****ON A/C A380-800 Models**

NOTE: THESE CURVES ARE GIVEN FOR INFORMATION ONLY. THE APPROVED VALUES ARE STATED IN THE "OPERATING MANUALS" SPECIFIC TO THE AIRLINE OPERATING THE AIRCRAFT.

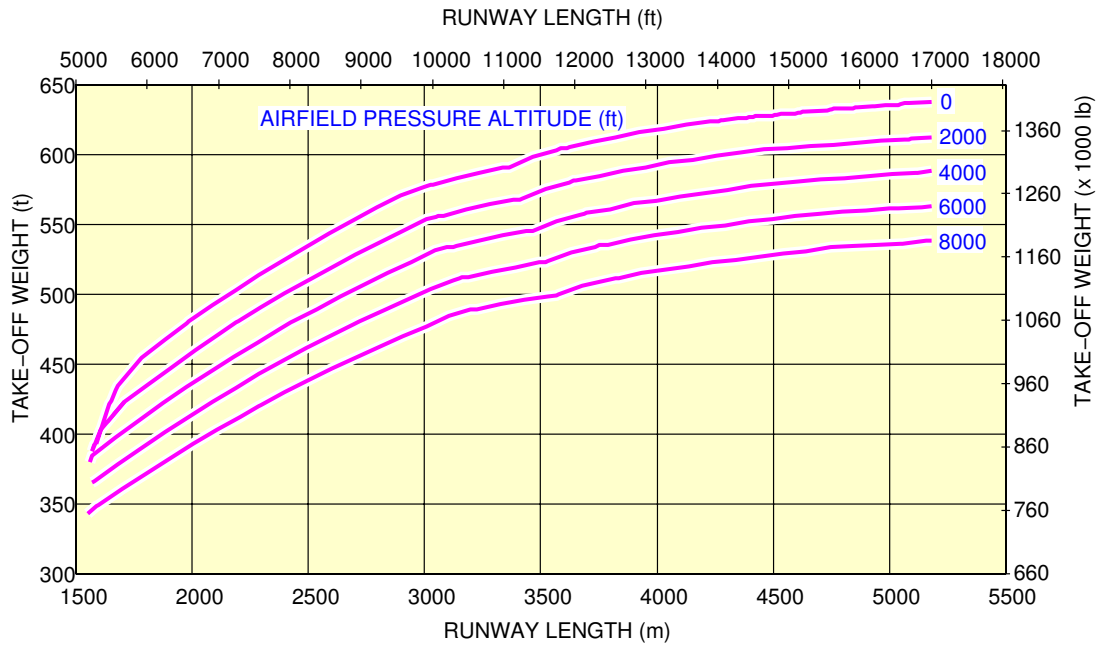

L_AC_030301_1_0010101_01_00

Take-Off Weight Limitation
ISA Conditions - TRENT 900 Engines



AIRPLANE CHARACTERISTICS

**ON A/C A380-800 Models

NOTE: THESE CURVES ARE GIVEN FOR INFORMATION ONLY.
THE APPROVED VALUES ARE STATED IN THE "OPERATING MANUALS"
SPECIFIC TO THE AIRLINE OPERATING THE AIRCRAFT.

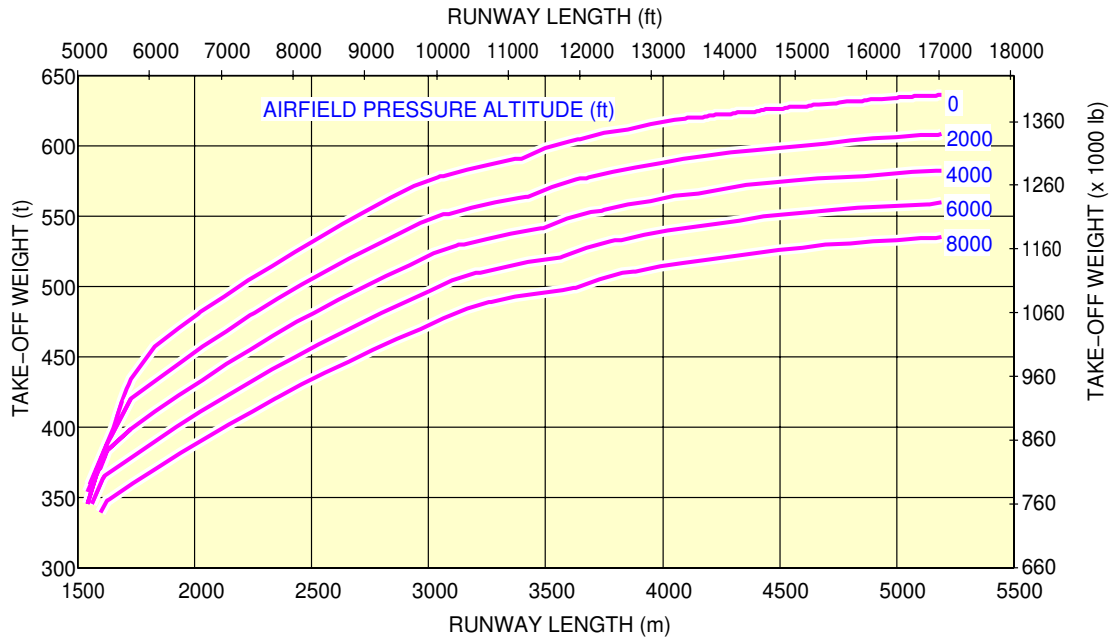

L_AC_030301_1_0080101_01_00

Take-Off Weight Limitation
ISA Conditions - GP 7200 Engines



AIRPLANE CHARACTERISTICS

****ON A/C A380-800F Models**

Take-Off Weight Limitation - Freighter

1. This section gives the take-off weight limitation at ISA conditions.



AIRPLANE CHARACTERISTICS

****ON A/C A380-800F Models**

NOTE: THESE CURVES ARE GIVEN FOR INFORMATION ONLY. THE APPROVED VALUES ARE STATED IN THE "OPERATING MANUALS" SPECIFIC TO THE AIRLINE OPERATING THE AIRCRAFT.

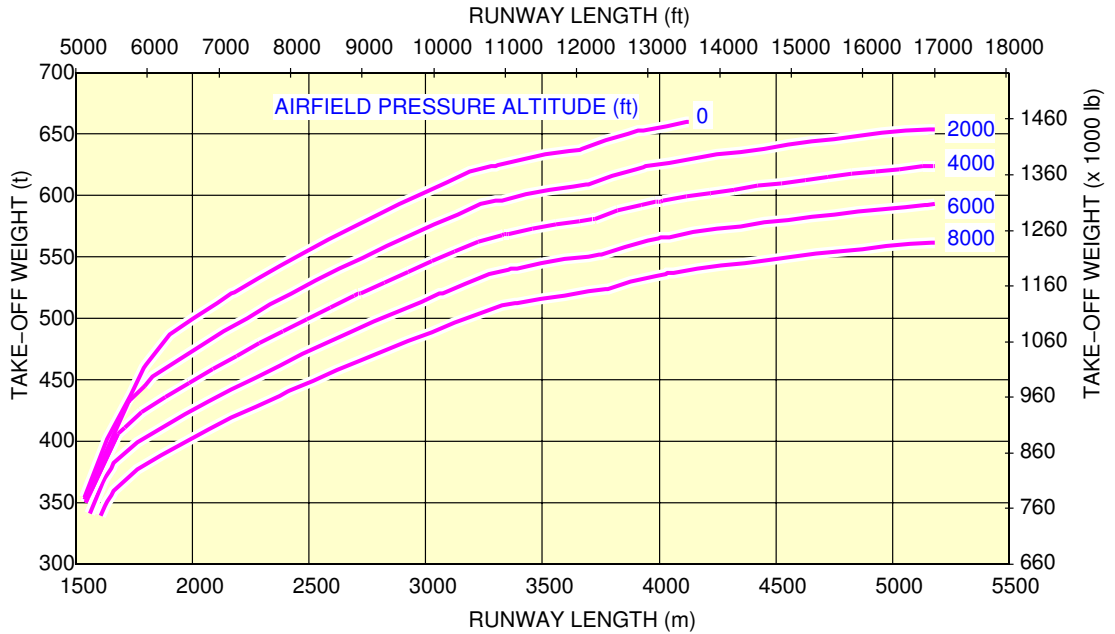

L_AC_030301_1_0060101_01_00

Take-Off Weight Limitation
ISA Conditions - TRENT 900 Engines

****ON A/C A380-800F Models**

NOTE: THESE CURVES ARE GIVEN FOR INFORMATION ONLY. THE APPROVED VALUES ARE STATED IN THE "OPERATING MANUALS" SPECIFIC TO THE AIRLINE OPERATING THE AIRCRAFT.

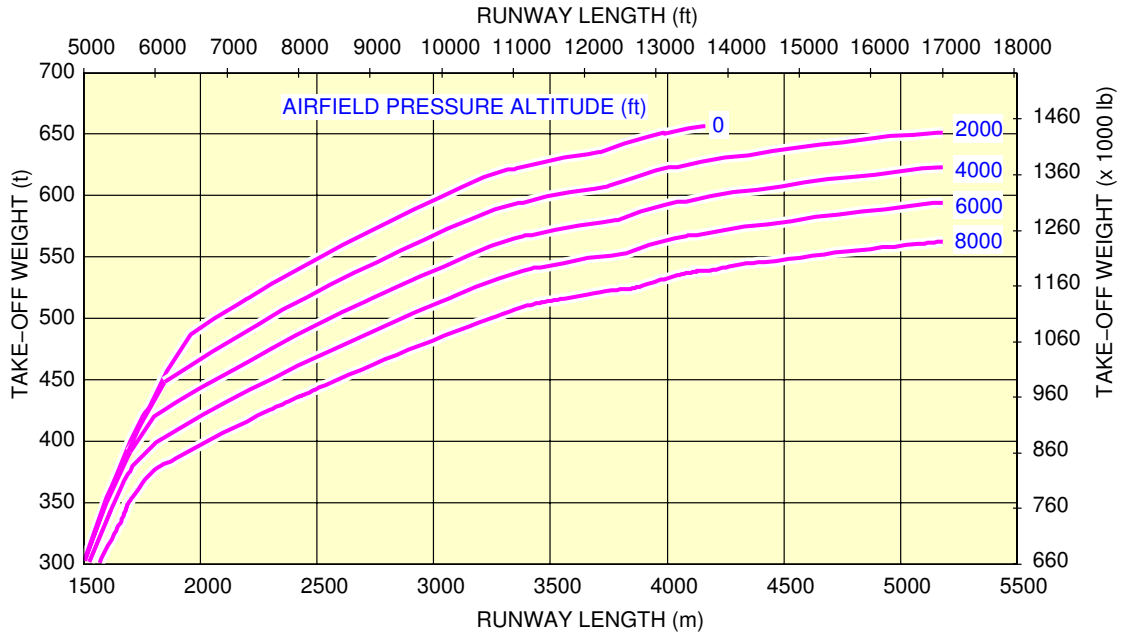

L_AC_030301_1_0090101_01_00

Take-Off Weight Limitation
ISA Conditions - GP 7200 Engines



AIRPLANE CHARACTERISTICS

3-3-2 ISA + 15 ° C (59 ° F)

****ON A/C A380-800 Models**

ISA + 15 ° C (59 ° F) - Pax

1. This section gives the take-off weight limitation at ISA +15° C (59° F) conditions.



AIRPLANE CHARACTERISTICS

****ON A/C A380-800 Models**

NOTE: THESE CURVES ARE GIVEN FOR INFORMATION ONLY.
THE APPROVED VALUES ARE STATED IN THE "OPERATING MANUALS"
SPECIFIC TO THE AIRLINE OPERATING THE AIRCRAFT.

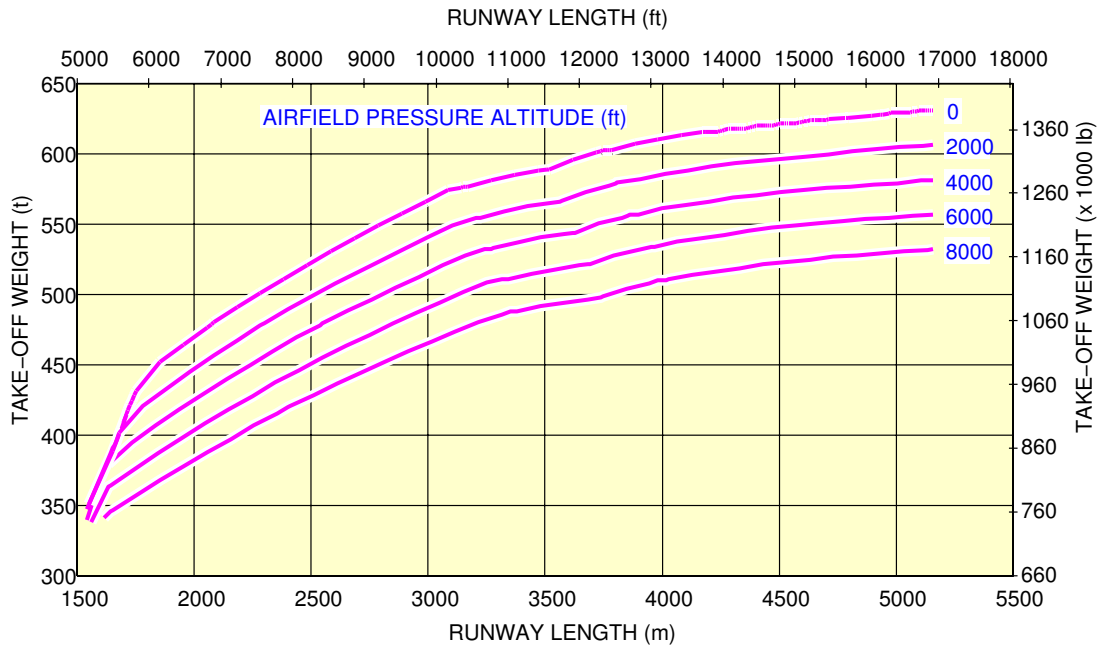

L_AC_030302_1_0010101_01_00

Take-Off Weight Limitation
ISA + 15 °C (59 °F) - TRENT 900 Engines

****ON A/C A380-800 Models**

NOTE: THESE CURVES ARE GIVEN FOR INFORMATION ONLY.
THE APPROVED VALUES ARE STATED IN THE "OPERATING MANUALS"
SPECIFIC TO THE AIRLINE OPERATING THE AIRCRAFT.

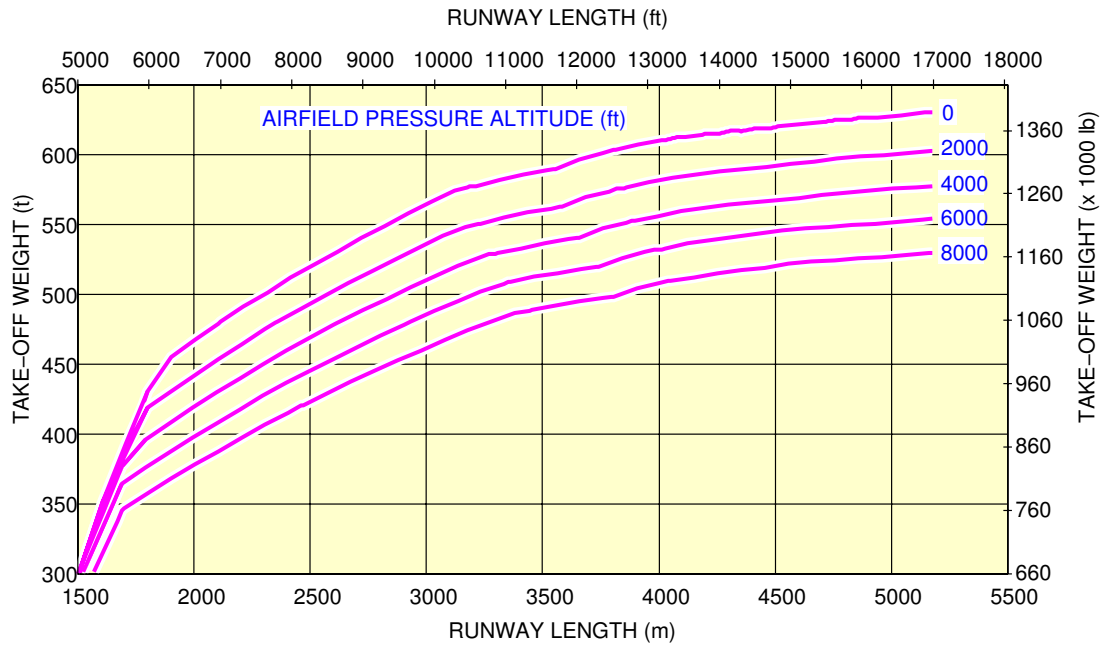

L_AC_030302_1_0080101_01_00

Take-Off Weight Limitation
ISA + 15 °C (59 °F) - GP 7200 Engines



AIRPLANE CHARACTERISTICS

****ON A/C A380-800F Models**

ISA + 15 °C (59 °F) - Freighter

1. This section gives the take-off weight limitation at ISA +15 °C (59 °F) conditions.

****ON A/C A380-800F Models**

NOTE: THESE CURVES ARE GIVEN FOR INFORMATION ONLY.
THE APPROVED VALUES ARE STATED IN THE "OPERATING MANUALS"
SPECIFIC TO THE AIRLINE OPERATING THE AIRCRAFT.

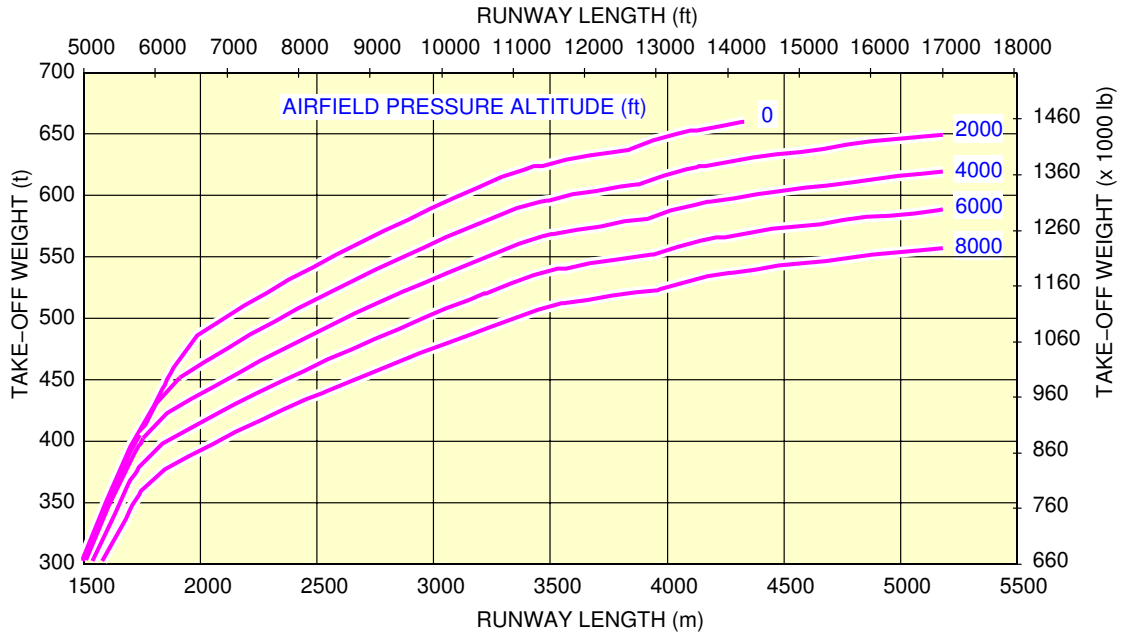

L_AC_030302_1_0060101_01_00

Take-Off Weight Limitation
ISA + 15 °C (59 °F) - TRENT 900 Engines

****ON A/C A380-800F Models**

NOTE: THESE CURVES ARE GIVEN FOR INFORMATION ONLY.
THE APPROVED VALUES ARE STATED IN THE "OPERATING MANUALS"
SPECIFIC TO THE AIRLINE OPERATING THE AIRCRAFT.

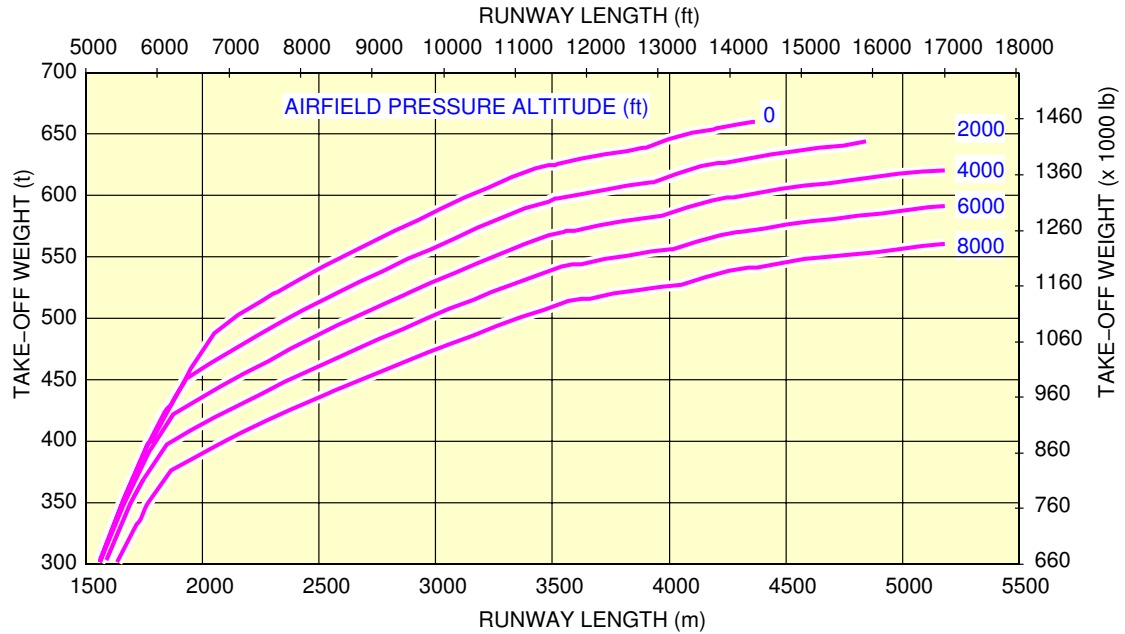

L_AC_030302_1_0090101_01_00

Take-Off Weight Limitation
ISA + 15 °C (59 °F) - GP 7200 Engines



AIRPLANE CHARACTERISTICS

3-4-0 Landing Field Length

**ON A/C A380-800 Models A380-800F Models

Landing Field Length

1. Landing Field Length



AIRPLANE CHARACTERISTICS

3-4-1 Landing Field Length

****ON A/C A380-800 Models**

Landing Field Length - Pax

1. This section gives the landing field length.



AIRPLANE CHARACTERISTICS

****ON A/C A380-800 Models**

NOTE: THESE CURVES ARE GIVEN FOR INFORMATION ONLY. THE APPROVED VALUES ARE STATED IN THE "OPERATING MANUALS" SPECIFIC TO THE AIRLINE OPERATING THE AIRCRAFT.

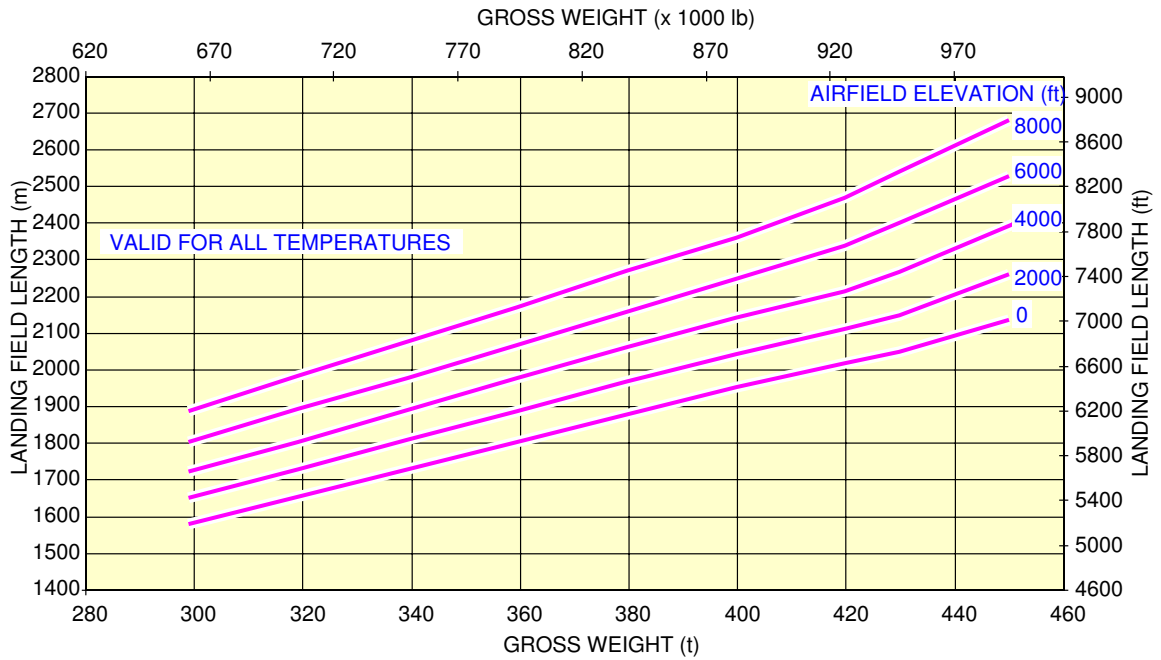

L_AC_030401_1_0010101_01_01

Landing Field Length
Landing Field Length - A380-800 Models



AIRPLANE CHARACTERISTICS

****ON A/C A380-800F Models**

Landing Field Length - Freighter

1. This section gives the landing field length.

****ON A/C A380-800F Models**

NOTE: THESE CURVES ARE GIVEN FOR INFORMATION ONLY.
THE APPROVED VALUES ARE STATED IN THE "OPERATING MANUALS"
SPECIFIC TO THE AIRLINE OPERATING THE AIRCRAFT.

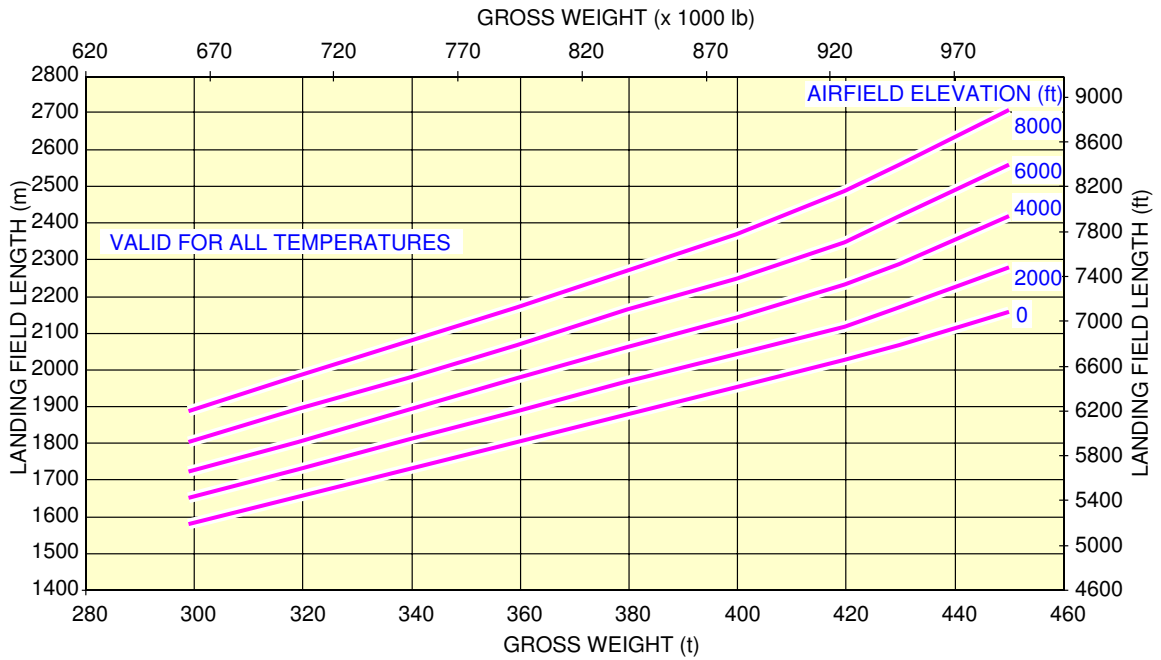

L_AC_030401_1_0030101_01_00

Landing Field Length
Landing Field Length - A380-800F Models



AIRPLANE CHARACTERISTICS

3-5-0 Final Approach Speed

**ON A/C A380-800 Models A380-800F Models

Final Approach Speed

1. Final Approach Speed



AIRPLANE CHARACTERISTICS

3-5-1 Final Approach Speed

****ON A/C A380-800 Models**

Final Approach Speed - Pax

1. This section gives the final approach speed.



AIRPLANE CHARACTERISTICS

****ON A/C A380-800 Models**

NOTE: THESE CURVES ARE GIVEN FOR INFORMATION ONLY.
THE APPROVED VALUES ARE STATED IN THE "OPERATING MANUALS"
SPECIFIC TO THE AIRLINE OPERATING THE AIRCRAFT.

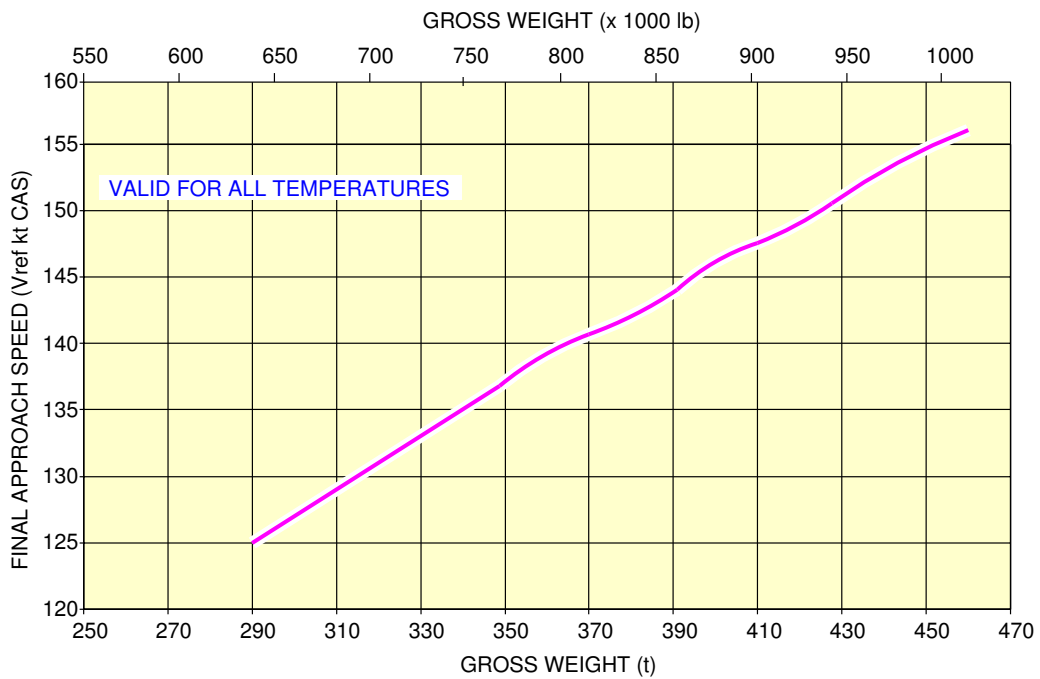

L_AC_030501_1_0010101_01_00

Final Approach Speed (CG=29%)
A380-800 Models



AIRPLANE CHARACTERISTICS

****ON A/C A380-800F Models**

Final Approach Speed - Freighter

1. This section gives the final approach speed.



AIRPLANE CHARACTERISTICS

****ON A/C A380-800F Models**

NOTE: THESE CURVES ARE GIVEN FOR INFORMATION ONLY.
THE APPROVED VALUES ARE STATED IN THE "OPERATING MANUALS"
SPECIFIC TO THE AIRLINE OPERATING THE AIRCRAFT.

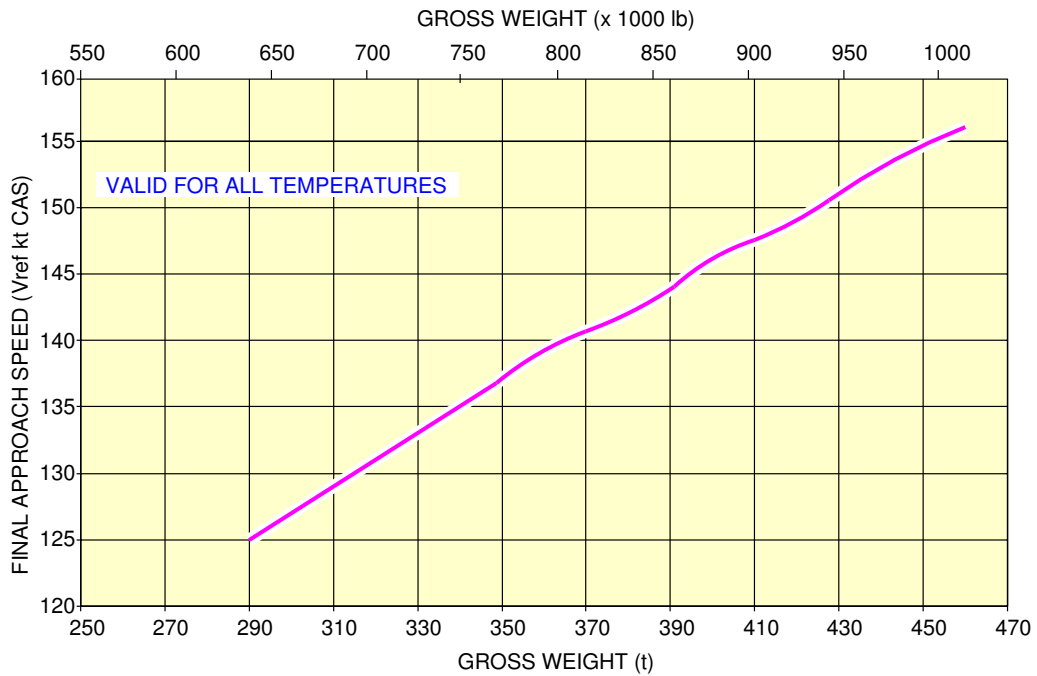

L_AC_030501_1_0030101_01_00

Final Approach Speed (CG=29%)
A380-800F Models



AIRPLANE CHARACTERISTICS

GROUND MANEUVERING

4-1-0 General Information

****ON A/C A380-800 Models A380-800F Models**

General

1. This section provides airplane turning capability and maneuvering characteristics.

For ease of presentation, this data has been determined from the theoretical limits imposed by the geometry of the aircraft, and where noted, provides for a normal allowance for tire slippage. As such, it reflects the turning capability of the aircraft in favorable operating circumstances. This data should only be used as guidelines for the method of determination of such parameters and for the maneuvering characteristics of this aircraft type.

In the ground operating mode, varying airline practices may demand that more conservative turning procedures be adopted to avoid excessive tire wear and reduce possible maintenance problems. Airline operating techniques will vary in the level of performance, over a wide range of operating circumstances throughout the world. Variations from standard aircraft operating patterns may be necessary to satisfy physical constraints within the maneuvering area, such as adverse grades, limited area or high risk of jet blast damage. For these reasons, ground maneuvering requirements should be coordinated with the using airlines prior to layout planning.



AIRPLANE CHARACTERISTICS

4-2-0 Turning Radii

****ON A/C A380-800 Models A380-800F Models**

Turning Radii

1. This section gives the turning radii.

**ON A/C A380-800 Models A380-800F Models

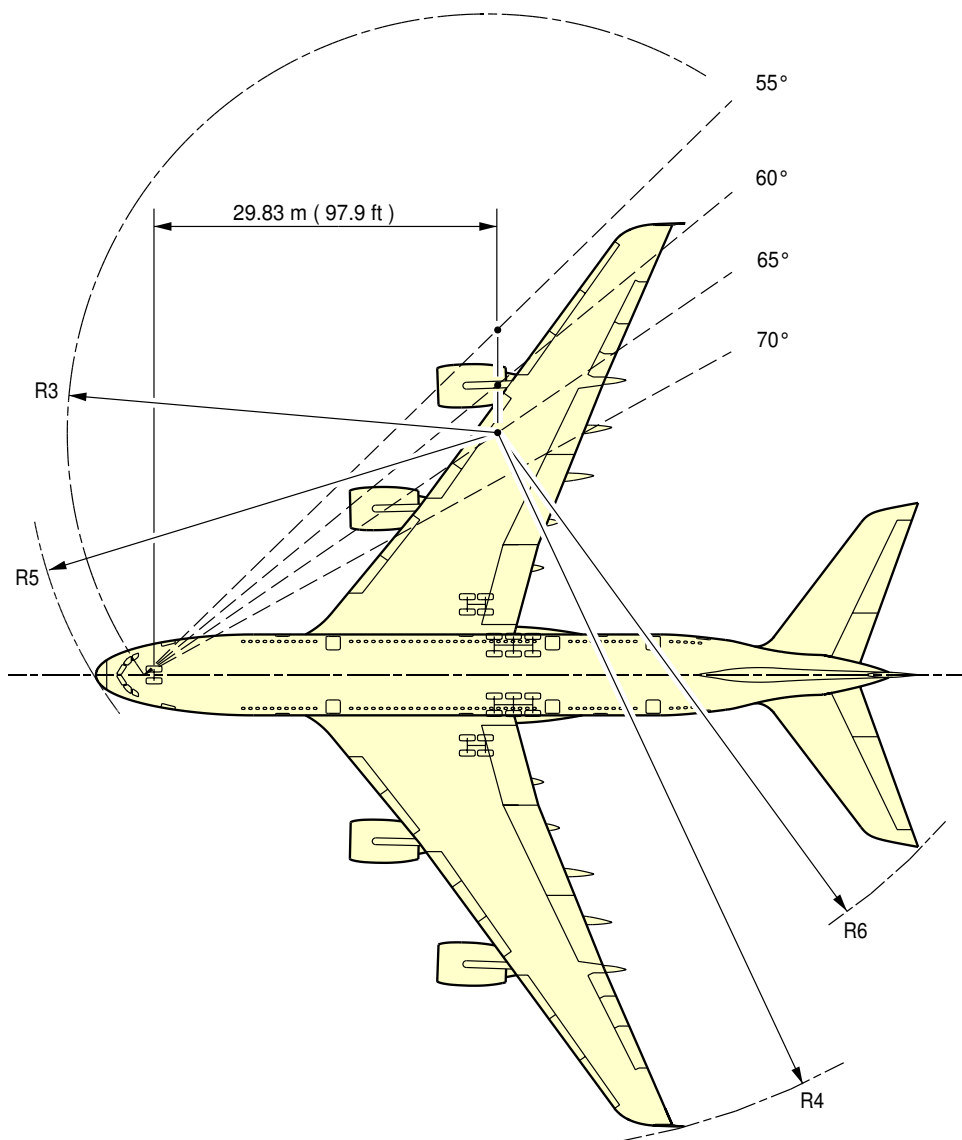

NOTE: SEE PAGE 2 FOR DIMENSIONS

L_AC_040200_1_0010101_01_00

Turning Radii
Turning Radii (Sheet 1)



AIRPLANE CHARACTERISTICS

**ON A/C A380-800 Models A380-800F Models

A380-800/800F TURNING RADII							
TYPE OF TURN	STEERING ANGLE	EFFECTIVE STEERING ANGLE		R3	R4	R5	R6
2	20°	17.9°	m	100.16	135.45	101.01	115.87
			ft	328.6	444.4	331.4	380.1
2	25°	22.7°	m	78.86	113.14	80.12	94.90
			ft	258.7	371.2	262.9	311.4
2	30°	27.5°	m	65.69	98.90	67.33	81.91
			ft	215.5	324.5	220.9	268.7
2	35°	32.1°	m	56.84	88.97	58.83	73.13
			ft	186.5	291.9	193.0	239.9
2	40°	36.6°	m	50.59	81.61	52.89	66.84
			ft	166.0	267.8	173.5	219.3
2	45°	41.0°	m	46.02	75.94	48.61	62.16
			ft	151.0	249.1	159.5	203.9
2	50°	45.1°	m	42.61	71.43	45.45	58.57
			ft	139.8	234.4	149.1	192.2
1	55°	51.2°	m	40.13	67.02	43.22	55.43
			ft	131.6	219.9	141.8	181.9
1	60°	57.3°	m	37.64	62.60	40.98	52.29
			ft	123.5	205.4	134.5	171.5
1	65°	63.4°	m	35.15	58.18	38.75	49.15
			ft	115.3	190.9	127.1	161.2
1	70°	69.5°	m	32.66	53.76	36.52	46.01
			ft	107.2	176.4	119.8	150.9

NOTE:

TYPE 1 TURNS USE :

ASYMMETRIC THRUST – BOTH ENGINES ON THE INSIDE OF THE TURN TO BE AT IDLE THRUST
DIFFERENTIAL BRAKING – BRAKING APPLIED TO THE WING GEAR WHEELS ON THE INSIDE OF THE TURN.

TYPE 2 TURNS USE :

SYMMETRIC THRUST AND NO BRAKING.

L_AC_040200_1_0020101_01_00

Turning Radii
Turning Radii (Sheet 2)



AIRPLANE CHARACTERISTICS

4-3-0 Minimum Turning Radii

****ON A/C A380-800 Models A380-800F Models**

Minimum Turning Radii

1. This section gives the minimum turning radii.

**ON A/C A380-800 Models A380-800F Models

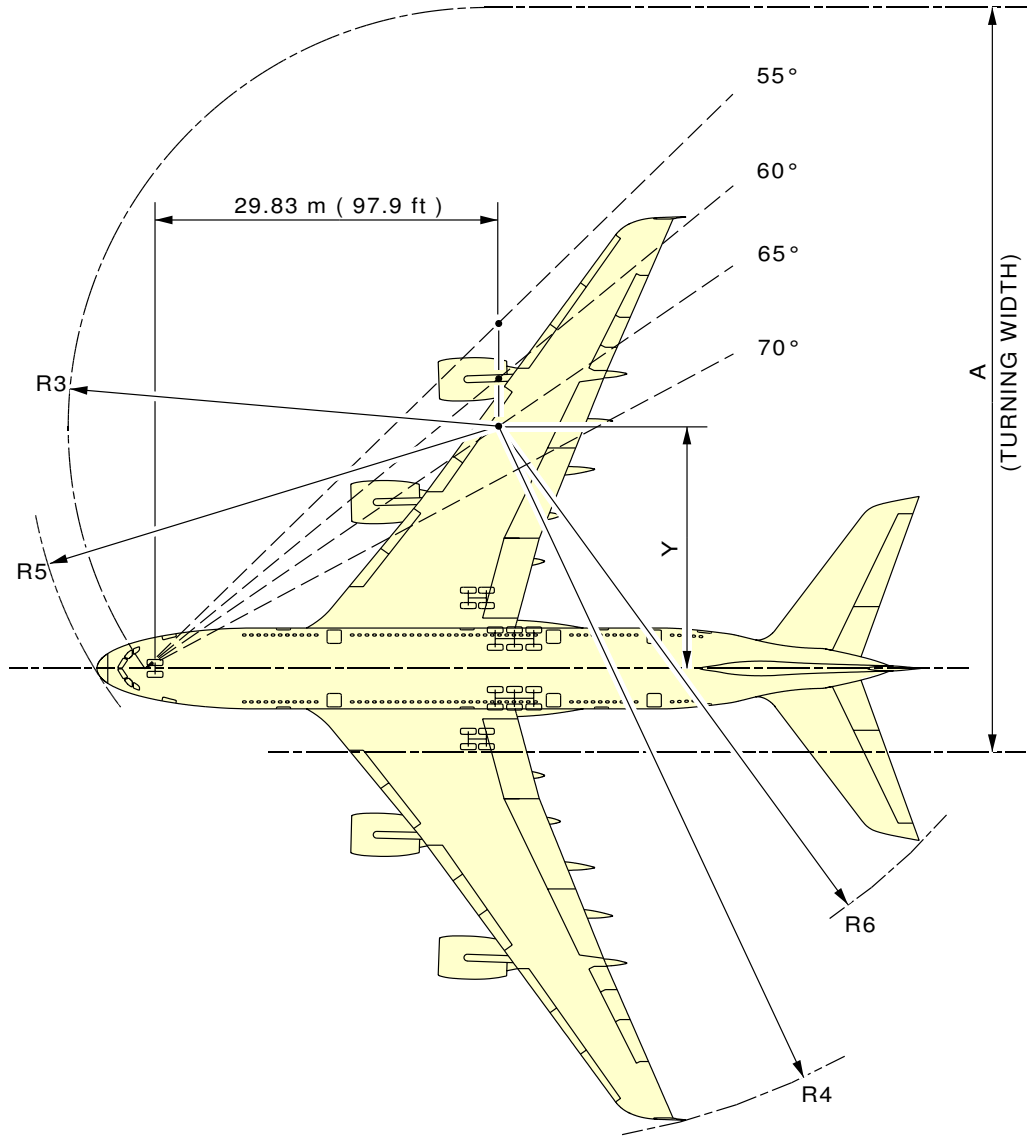

A380-800/800F Minimum Turning Radius									
Type of Turn	Steering Angle	Effective Steering Angle		Y	A	R3	R4	R5	R6
1	70°	69.5°	m	11.08	50.91	32.66	53.76	36.52	46.01
			ft	36.3	167.0	107.2	176.4	119.8	150.9

NOTE: TURN PERFORMED WITH ASYMMETRIC THRUST AND DIFFERENTIAL BRAKING

L_AC_040300_1_0010101_01_00

Minimum Turning Radii



AIRPLANE CHARACTERISTICS

4-4-0 Visibility from Cockpit in Static Position

**ON A/C A380-800 Models A380-800F Models

Visibility from Cockpit in Static Position

1. This section gives the visibility from cockpit in static position.

**ON A/C A380-800 Models A380-800F Models

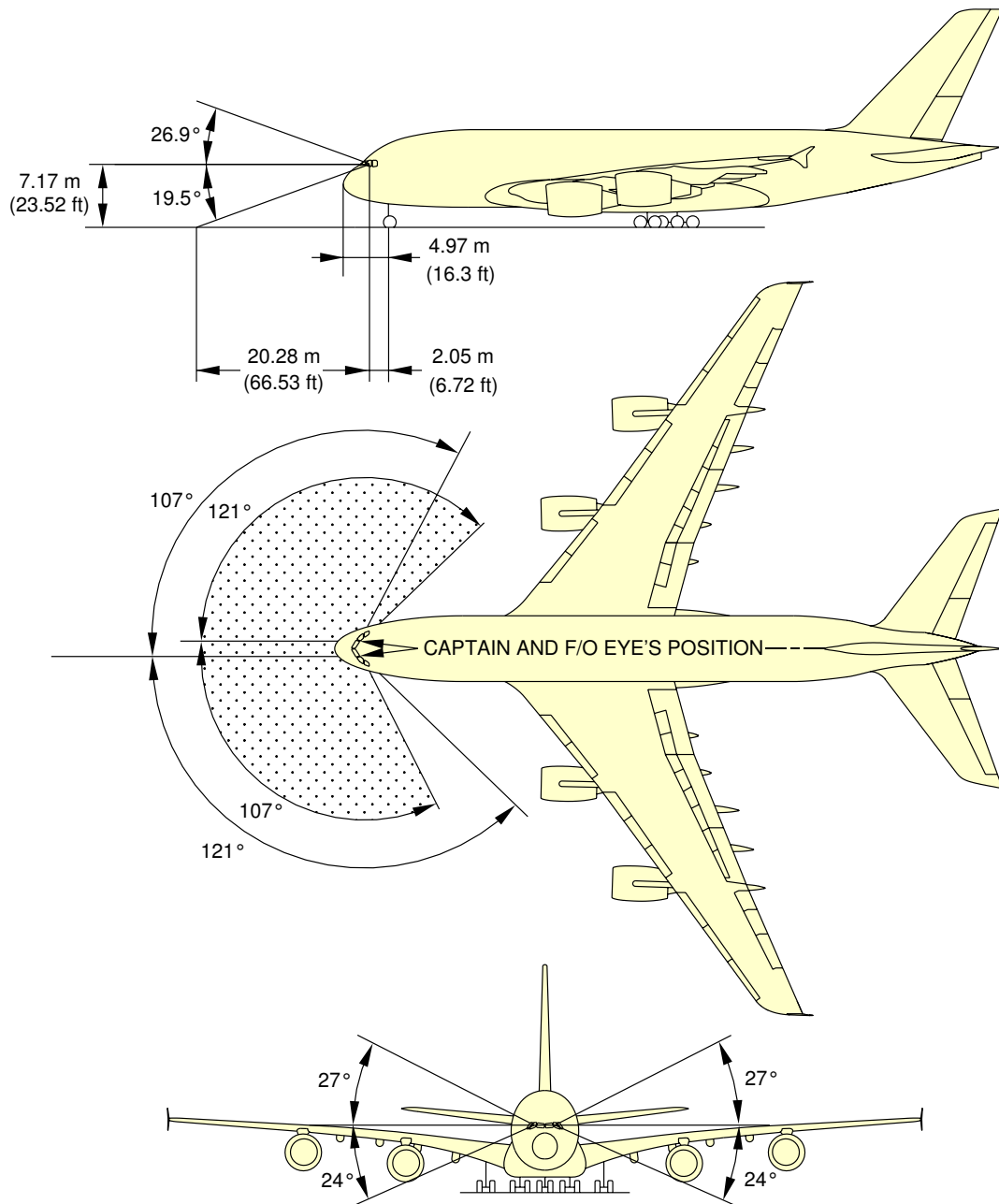

L_AC_040400_1_0010101_01_00

Visibility from Cockpit in Static Position



AIRPLANE CHARACTERISTICS

4-5-0 Runway and Taxiway Turn Paths

****ON A/C A380-800 Models A380-800F Models**

Runway and Taxiway Turn Paths

1. Runway and Taxiway Turn Paths



AIRPLANE CHARACTERISTICS

4-5-1 135° Turn - Runway to Taxiway

****ON A/C A380-800 Models A380-800F Models**

135° Turn - Runway to Taxiway

1. This section gives the 135° turn – runway to taxiway.

****ON A/C A380-800 Models A380-800F Models**

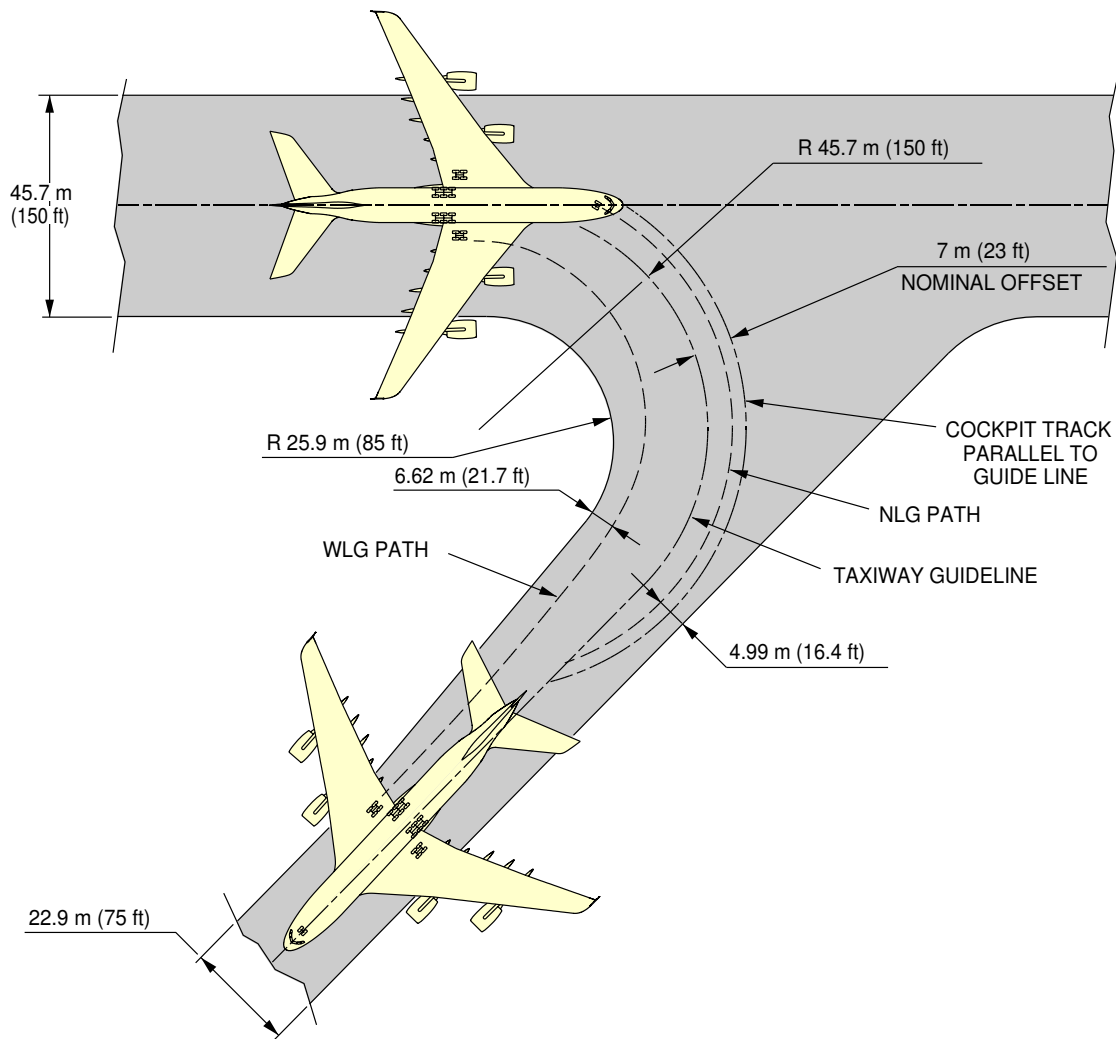

NOTE: FAA GROUP V JUDGEMENTAL OVERSTEER METHOD

L_AC_040501_1_0010101_01_00

135° Turn – Runway to Taxiway
135° Turn – Runway to Taxiway (Sheet 1)

**ON A/C A380-800 Models A380-800F Models

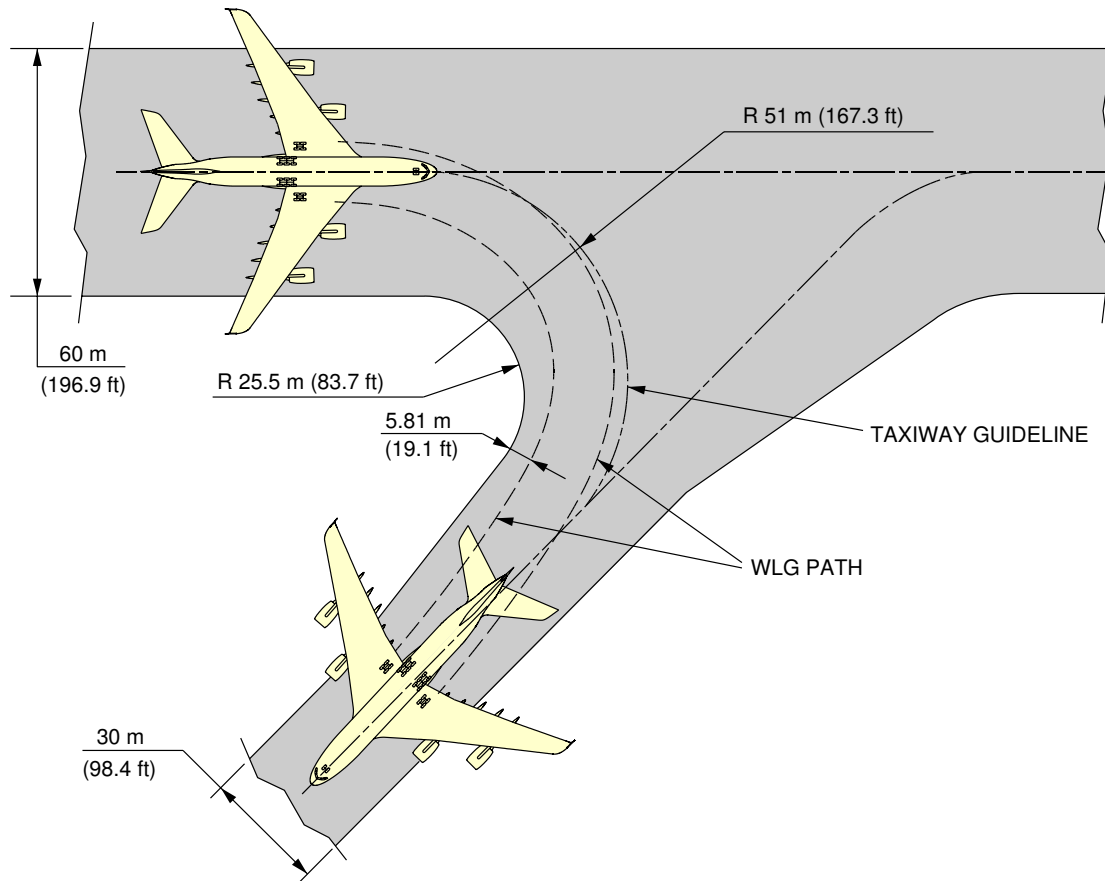

NOTE: FAA GROUP VI COCKPIT TRACKS CENTRELINE METHOD

L_AC_040501_1_0020101_01_00

135° Turn – Runway to Taxiway
135° Turn – Runway to Taxiway (Sheet 2)



AIRPLANE CHARACTERISTICS

4-5-2 90° Turn - Runway to Taxiway

****ON A/C A380-800 Models A380-800F Models**

90° Turn - Runway to Taxiway

1. This section gives the 90° turn – runway to taxiway.

****ON A/C A380-800 Models A380-800F Models**

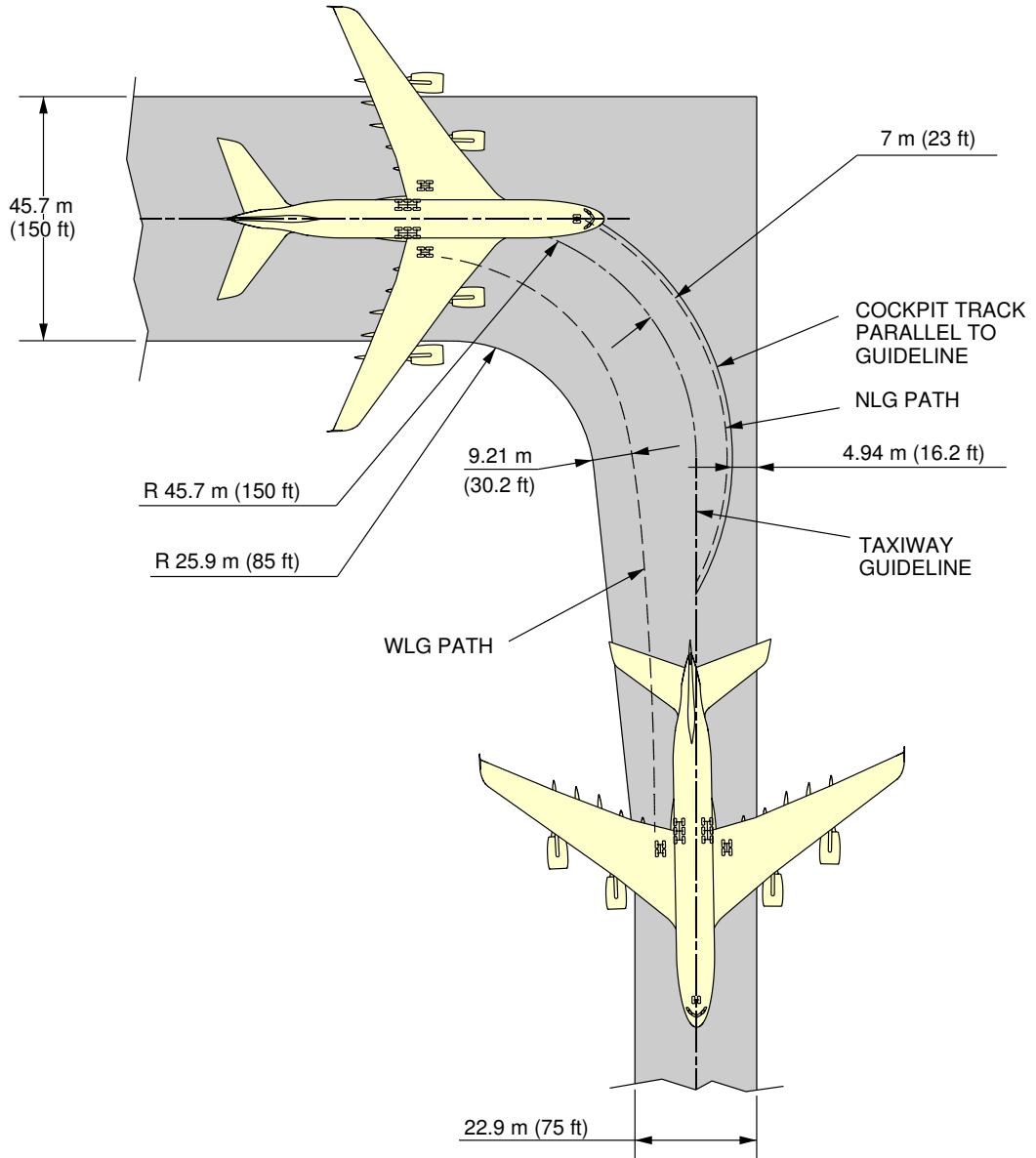

NOTE: FAA GROUP V JUDGEMENTAL OVERSTEER METHOD

L_AC_040502_1_0010101_01_00

90° Turn – Runway to Taxiway
90° Turn – Runway to Taxiway (Sheet 1)

**ON A/C A380-800 Models A380-800F Models

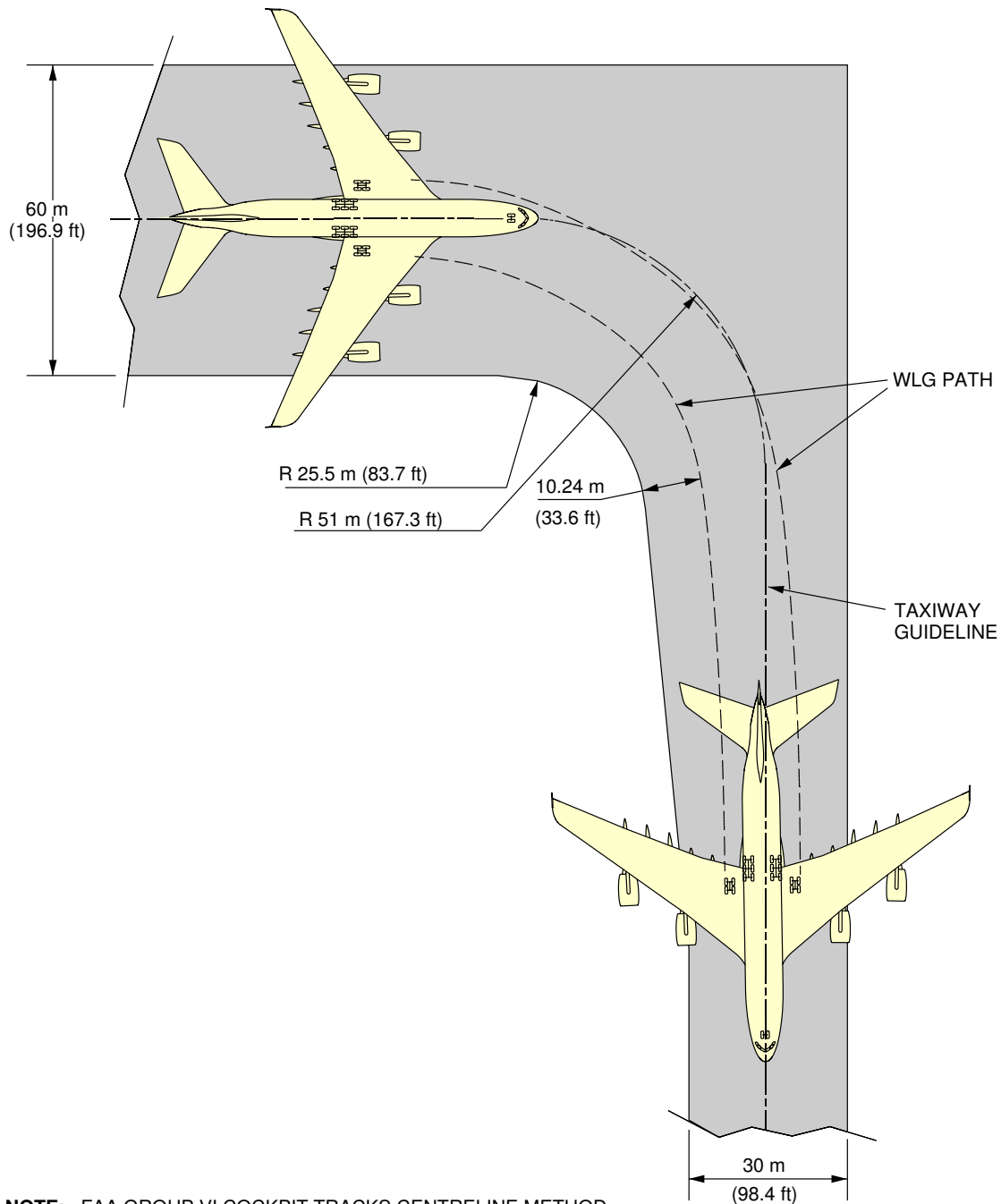

NOTE: FAA GROUP VI COCKPIT TRACKS CENTRELINE METHOD

L_AC_040502_1_0020101_01_00

90° Turn – Runway to Taxiway
90° Turn – Runway to Taxiway (Sheet 2)



AIRPLANE CHARACTERISTICS

4-5-3 180° Turn on a Runway

****ON A/C A380-800 Models A380-800F Models**

180° Turn on a Runway

1. This section gives the 180° turn on a runway.



AIRPLANE CHARACTERISTICS

4-5-4 90° Turn - Taxiway to Taxiway

****ON A/C A380-800 Models A380-800F Models**

90° Turn - Taxiway to Taxiway

1. This section gives the 90° turn - taxiway to taxiway.

****ON A/C A380-800 Models A380-800F Models**

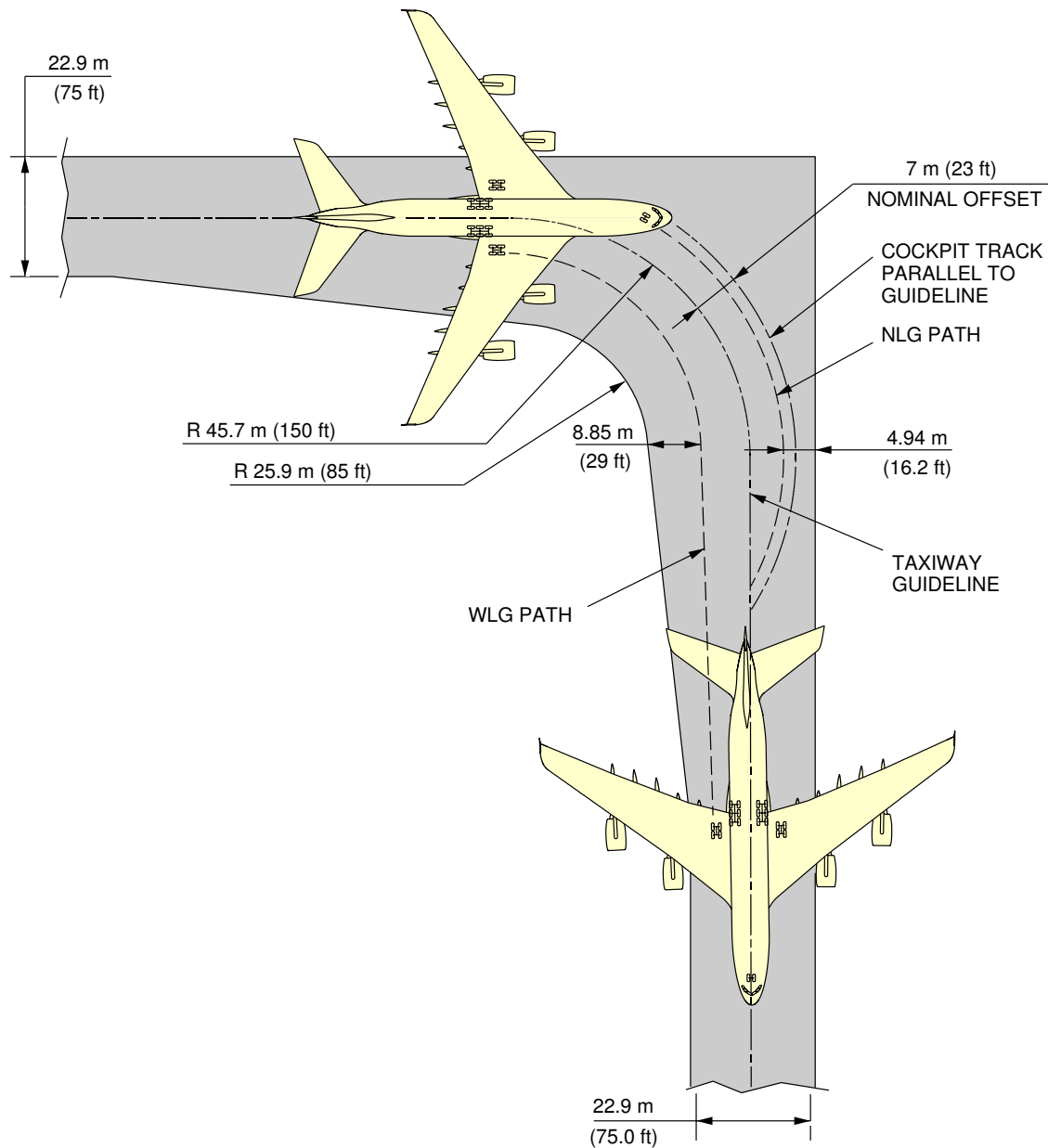

NOTE: FAA GROUP V JUDGEMENTAL OVERSTEER METHOD

L_AC_040504_1_0010101_01_00

90° Turn – Taxiway to Taxiway
90° Turn – Taxiway to Taxiway (Sheet 1)

****ON A/C A380-800 Models A380-800F Models**

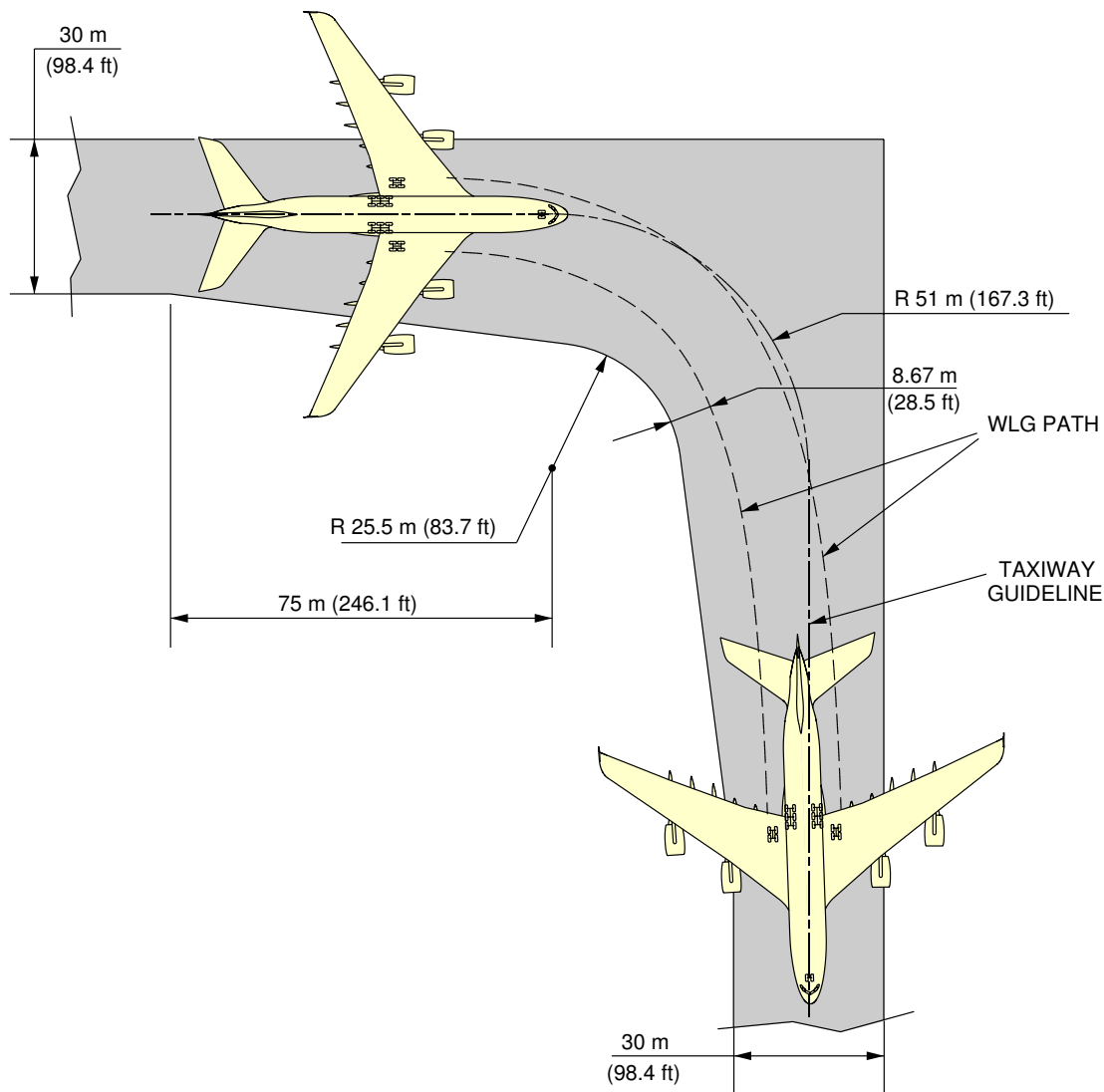

NOTE: FAA GROUP VI COCKPIT TRACKS CENTRELINE METHOD

L_AC_040504_1_0020101_01_00

90° Turn – Taxiway to Taxiway
90° Turn – Taxiway to Taxiway (Sheet 2)



AIRPLANE CHARACTERISTICS

4-5-5 135 ° Turn - Taxiway to Taxiway

****ON A/C A380-800 Models A380-800F Models**

135 ° Turn - Taxiway to Taxiway

1. This section gives the 135 ° turn - taxiway to taxiway.

****ON A/C A380-800 Models A380-800F Models**

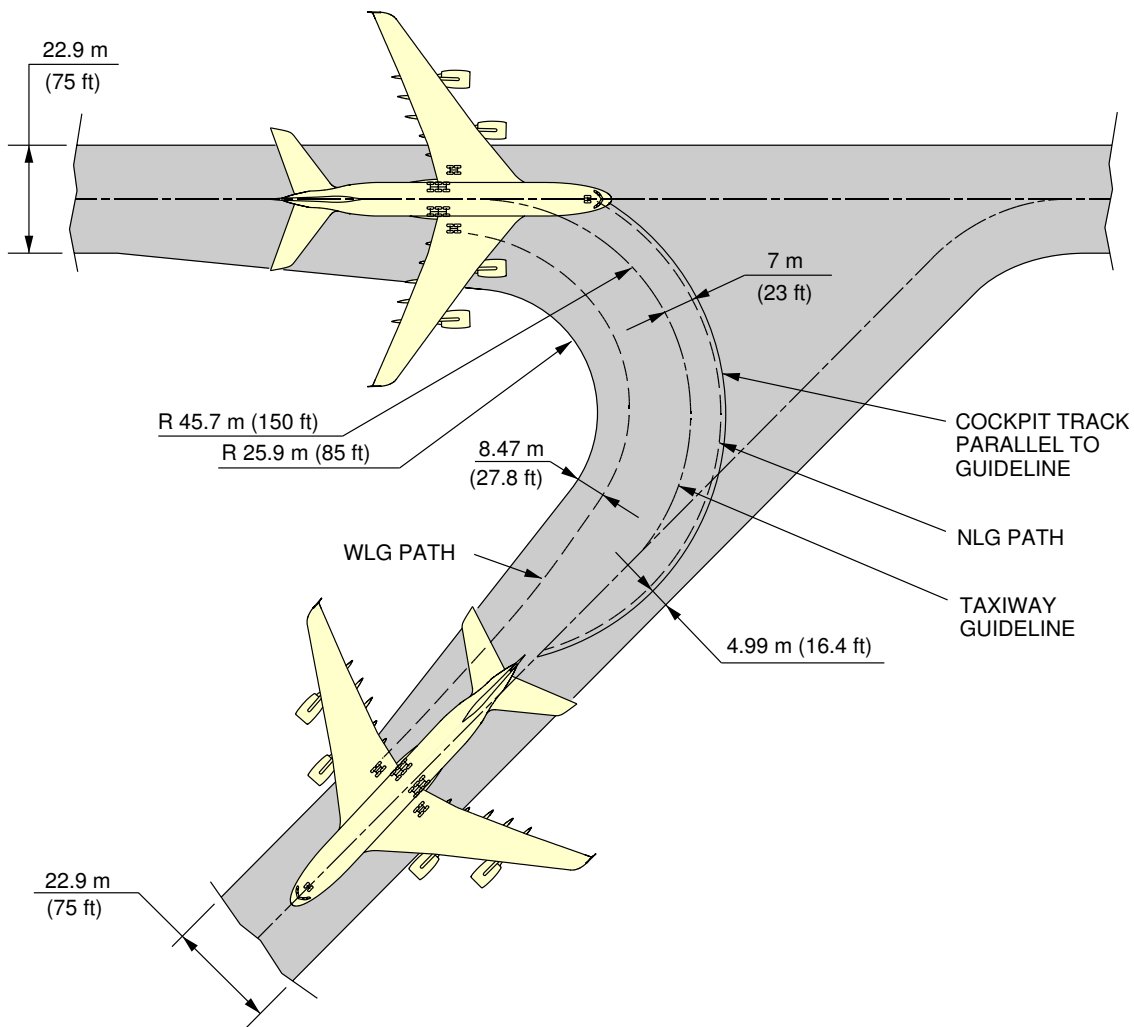

NOTE: FAA GROUP V JUDGEMENTAL OVERSTEER METHOD

L_AC_040505_1_0010101_01_00

135° Turn – Taxiway to Taxiway
135° Turn – Taxiway to Taxiway (Sheet 1)

**ON A/C A380-800 Models A380-800F Models

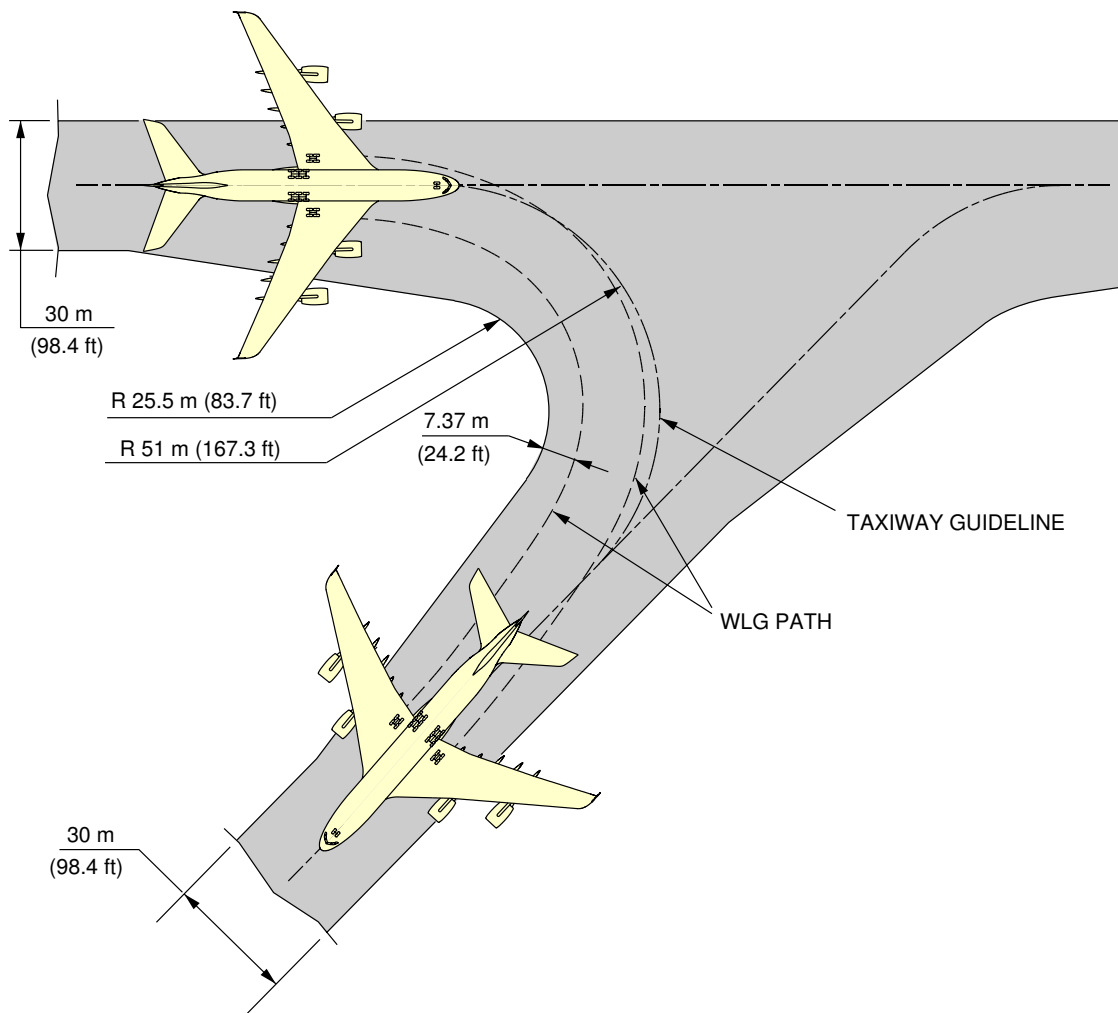

NOTE: FAA GROUP VI COCKPIT TRACKS CENTRELINE METHOD

L_AC_040505_1_0020101_01_00

135° Turn – Taxiway to Taxiway
135° Turn – Taxiway to Taxiway (Sheet 2)



AIRPLANE CHARACTERISTICS

4-6-0 Runway Holding Bay (Apron)

****ON A/C A380-800 Models A380-800F Models**

Runway Holding Bay (Apron)

1. This section gives the runway holding bay (Apron).

****ON A/C A380-800 Models A380-800F Models**

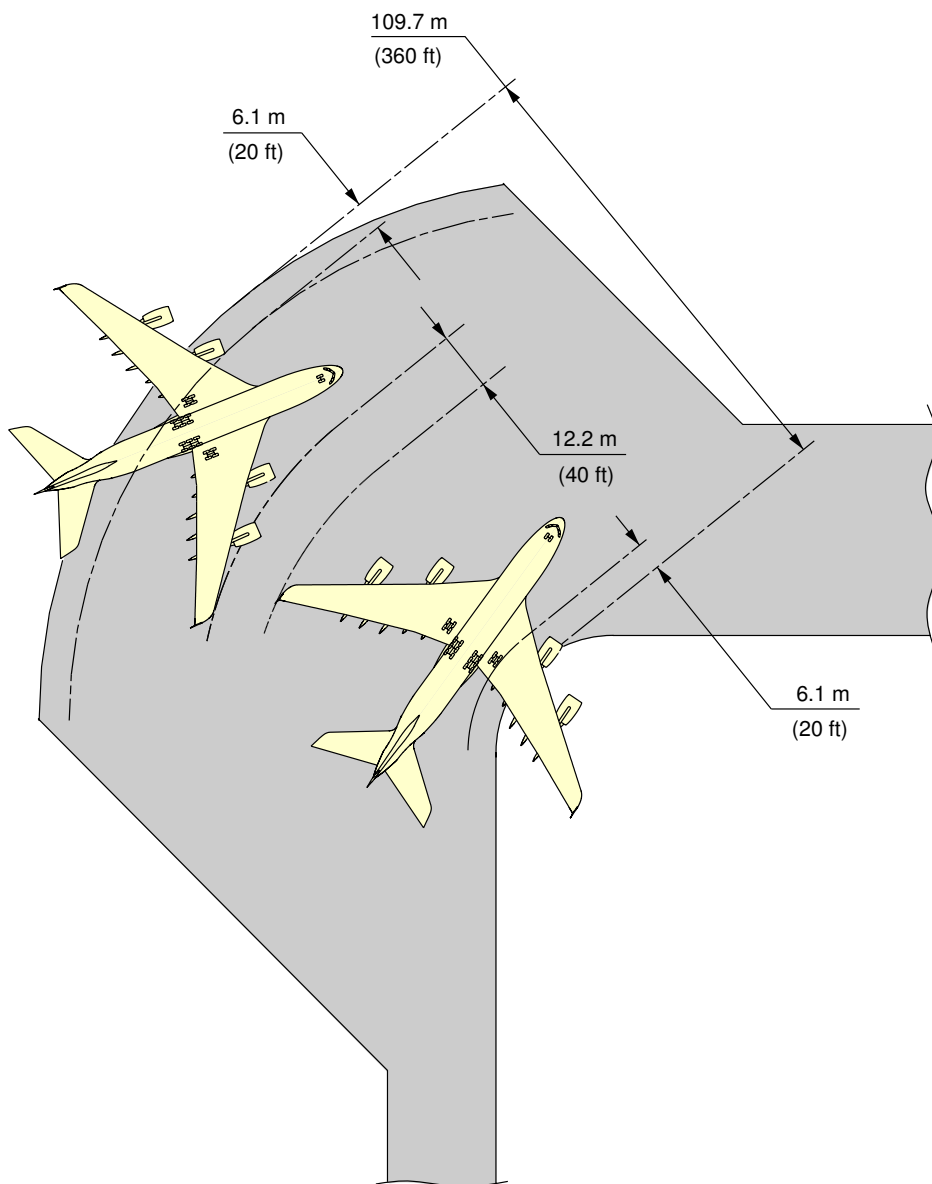

NOTE: COORDINATE WITH USING AIRLINE FOR SPECIFIC PLANNED OPERATING PROCEDURE

L_AC_040600_1_0010101_01_00

Runway Holding Bay (Apron)

4-7-0 Airplane Parking****ON A/C A380-800 Models A380-800F Models**Airplane Parking

1. The following figures and charts show the rectangular space required for parking against the terminal building :
 - A. Steering Geometry
 - B. Minimum Parking Space Requirements

**ON A/C A380-800 Models A380-800F Models

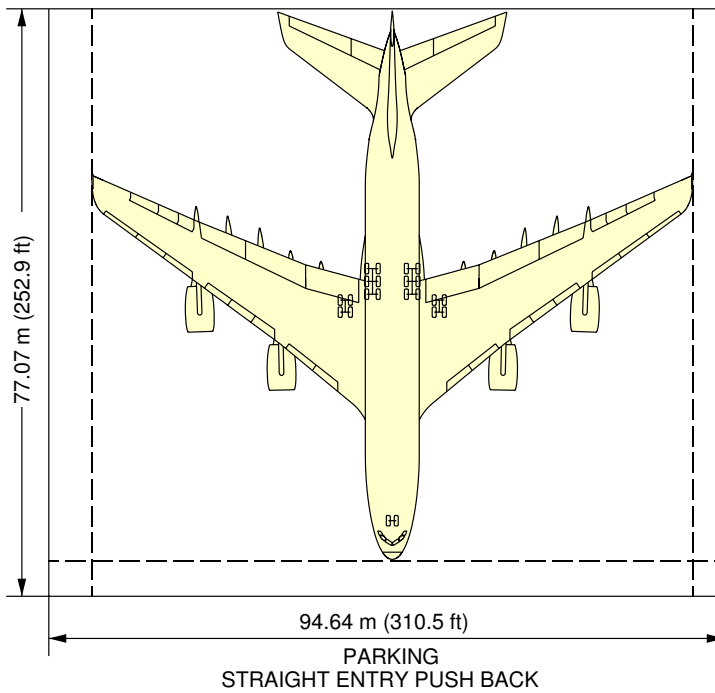
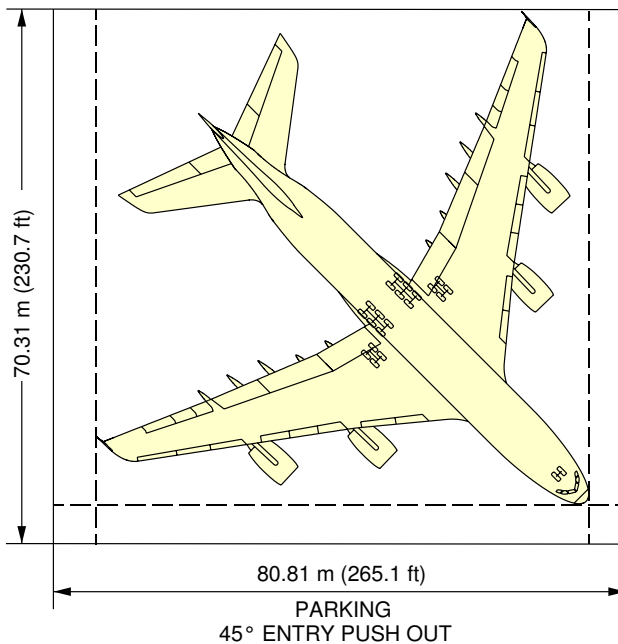

L_AC_040700_1_0010101_01_00

Airplane Parking
Steering Geometry

**ON A/C A380-800 Models A380-800F Models

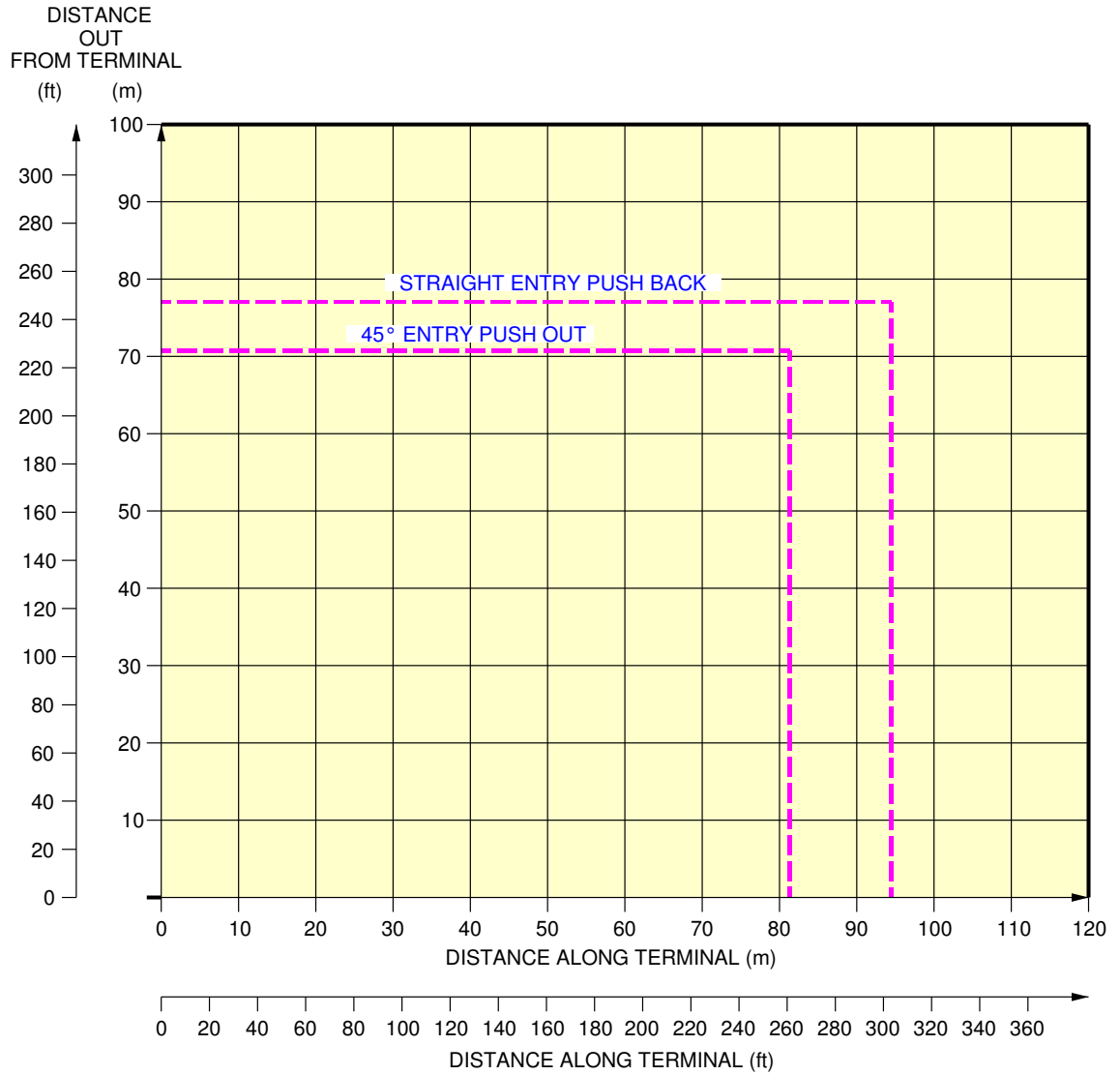

L_AC_040700_1_0020101_01_00

Airplane Parking
Minimum Parking Space Requirements



AIRPLANE CHARACTERISTICS

4-8-0 Airplane Mooring

****ON A/C A380-800 Models A380-800F Models**

General

1. This section provides information on airplane mooring.

**ON A/C A380-800 Models A380-800F Models

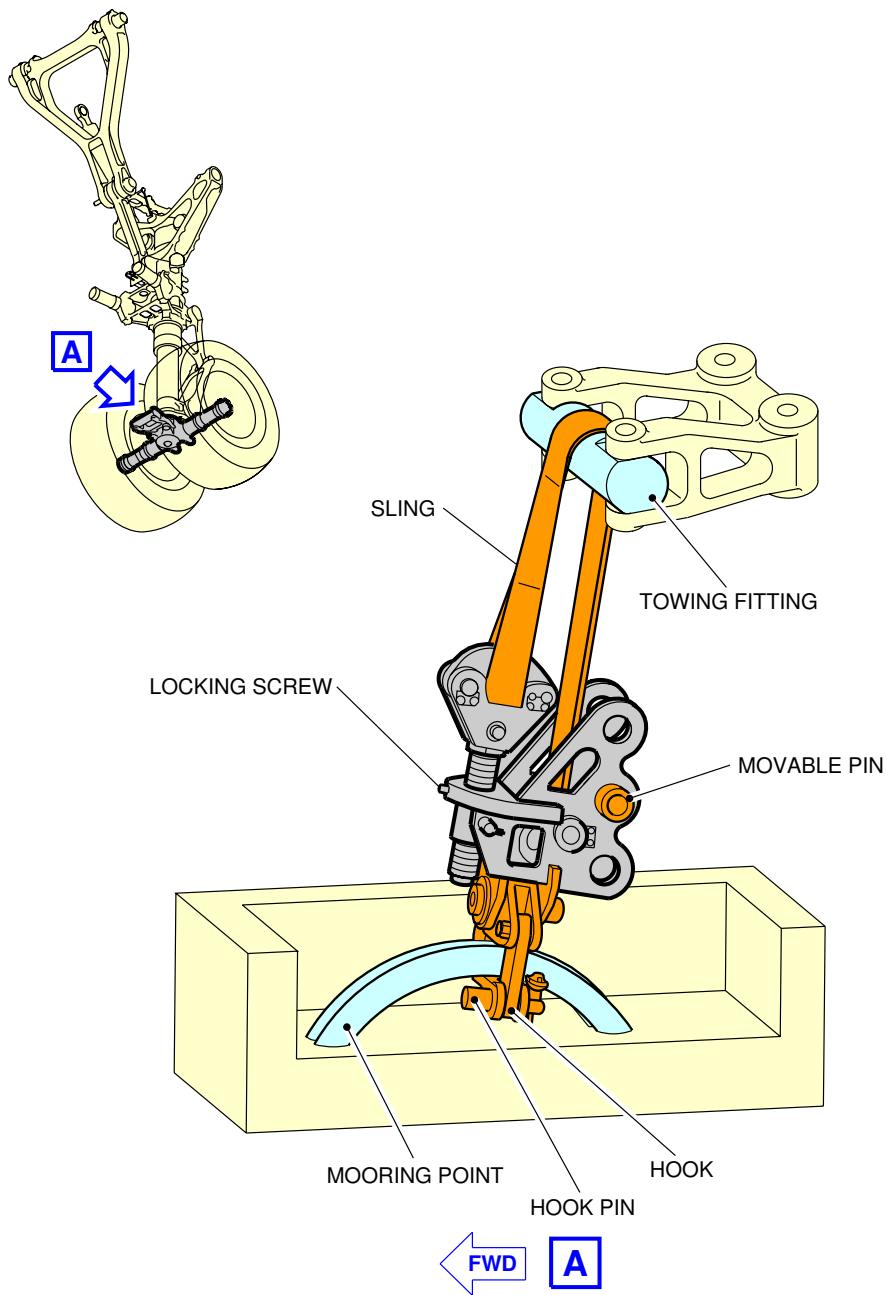

L_AC_040800_1_0010101_01_00

Airplane Mooring



AIRPLANE CHARACTERISTICS

TERMINAL SERVICING

5-1-0 Airplane Servicing Arrangements

****ON A/C A380-800 Models A380-800F Models**

Airplane Servicing Arrangements

1. This section provides typical ramp layouts, showing the various GSE items in position during typical turn-round scenarios.

These ramp layouts show typical arrangements only. Each operator will have its own specific requirements/regulations for the positioning and operation on the ramp.

For each ramp layout, the associated typical turn-round time is given in a Chart in the section 5-2 for passenger aircraft and section 5-3 for cargo aircraft.



AIRPLANE CHARACTERISTICS

5-1-1 Typical Ramp Layout - Two Bridges - Standard Servicing Via Main Deck and Upper Deck

****ON A/C A380-800 Models**

Typical Ramp Layout - Two Bridges - Standard Servicing

1. This section gives the typical ramp layout - two bridges - servicing via main deck and upper deck.

****ON A/C A380-800 Models**

AC: AIR COND UNIT
 AIR: AIR START UNIT
 CAT: CATERING VEHICLE
 CLEAN: CLEANING VEHICLE
 CONVEYOR: CONVEYOR BELT
 FUEL: FUEL HYDRANT DISPENSER

GPU: GROUND POWER UNIT
 LV: LAVATORY VEHICLE
 PL: PALLET/CONTAINER LOADER
 TOW: TOWING TRACTOR
 UDCAT: UPPER DECK CATERING VEHICLE
 WV: POTABLE WATER VEHICLE

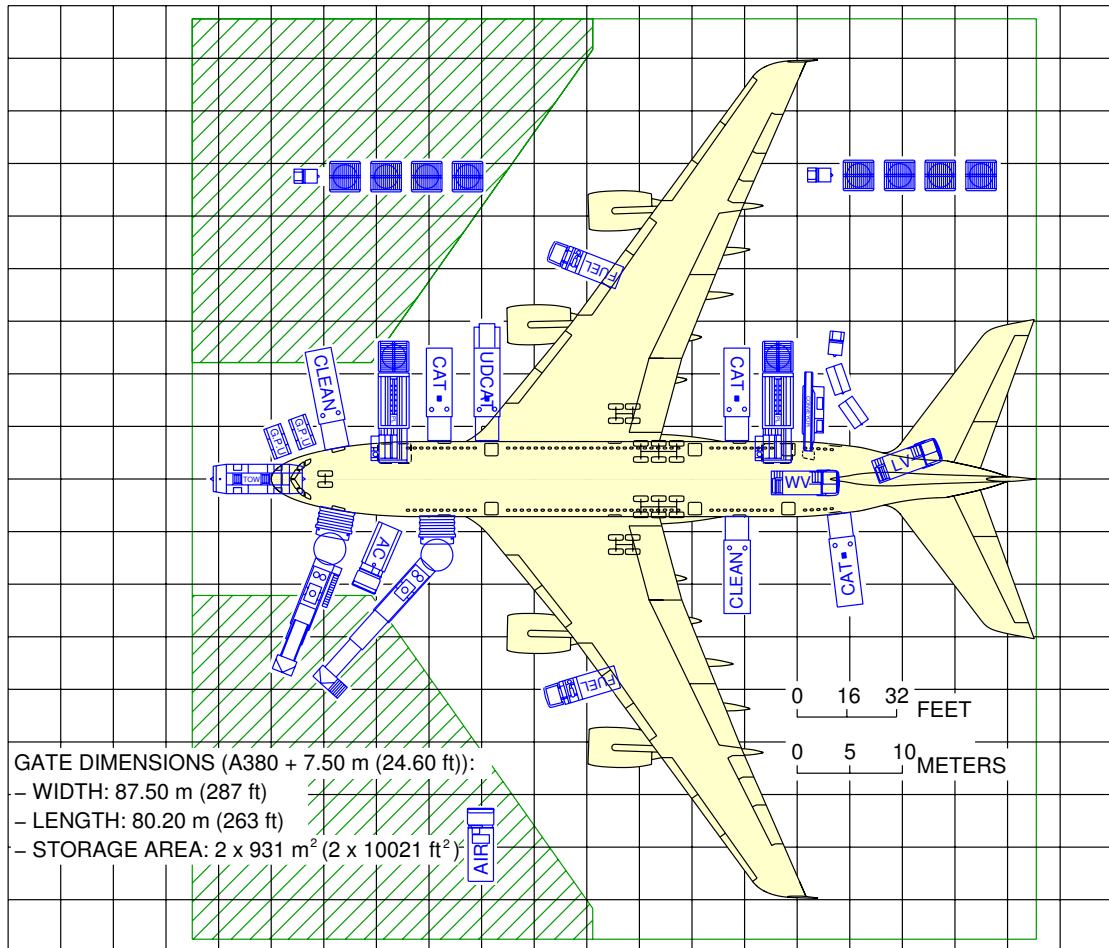

RL28/B1A/800/STD

L_AC_050101_1_0010101_01_00

Baseline Ramp Layout – Two Bridges
 Servicing Via Main and Upper Decks



AIRPLANE CHARACTERISTICS

5-1-2 Typical Ramp Layout - Two Bridges - Servicing Via Main Deck

****ON A/C A380-800 Models**

Typical Ramp Layout - Two Bridges - Servicing Via Main Deck

1. This section gives the typical ramp layout - two bridges - servicing via main deck.

**ON A/C A380-800 Models

AC: AIR COND UNIT
 AIR: AIR START UNIT
 CAT: CATERING VEHICLE
 CLEAN: CLEANING VEHICLE
 CONVEYOR: CONVEYOR BELT
 FUEL: FUEL HYDRANT DISPENSER

GPU: GROUND POWER UNIT
 LV: LAVATORY VEHICLE
 PL: PALLET/CONTAINER LOADER
 TOW: TOWING TRACTOR
 WV: POTABLE WATER VEHICLE

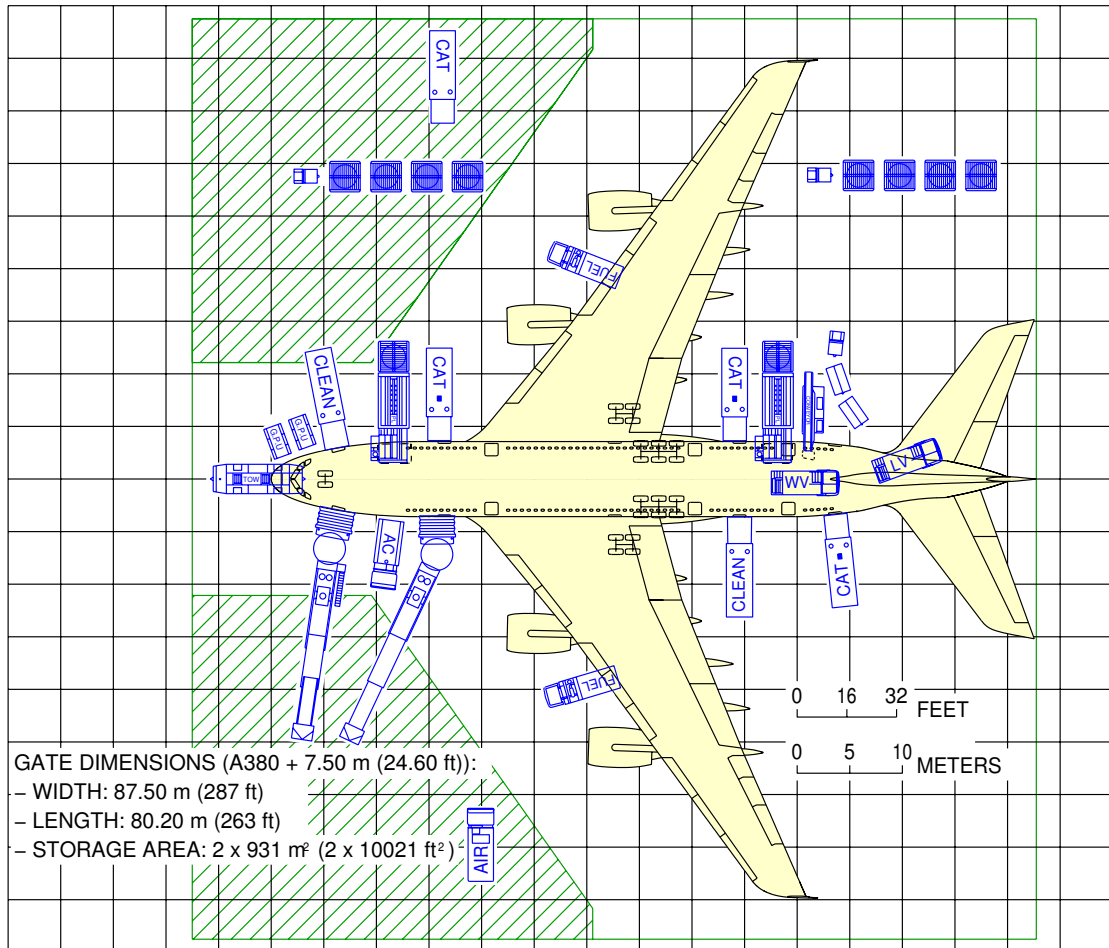

RL01/B1A/800/STD

L_AC_050102_1_0010101_01_00

Typical Ramp Layout – Two Bridges
 Servicing Via Main Deck



AIRPLANE CHARACTERISTICS

5-1-3 Opportunities of Direct Upper Deck Access for Airport and Airlines

****ON A/C A380-800 Models**

Opportunities of Direct Upper Deck Access for Airport and Airlines

1. This section gives the opportunities of direct upper deck access for airport and airlines.

**ON A/C A380-800 Models

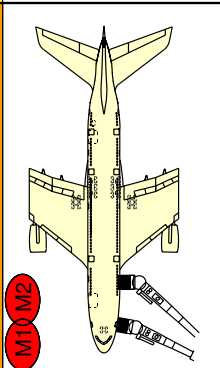
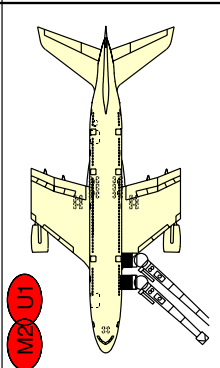
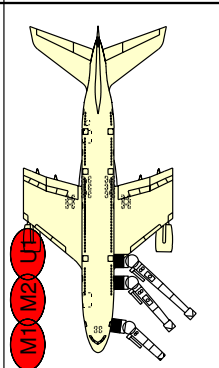
OPPORTUNITIES OF DIRECT UPPER DECK (UD) ACCESS FOR AIRPORTS & AIRLINES		TURN-ROUND TIME (TRT)		
SCENARIOS	PRODUCT & SERVICE DIFFERENTIATION	BASELINE	HIGH	VERY HIGH
	BASELINE	BASELINE		SIMILAR TO BASELINE MD ACCESS
	VERY HIGH	SIMILAR TO BASELINE MD ACCESS	BENEFITS REALISED DEPEND LARGELY ON CABIN LAYOUT & BOARDING PROCEDURES	

L_AC_050103_1_0010101_01_00

Opportunities of Direct Upper Deck Access for Airport and Airlines



AIRPLANE CHARACTERISTICS

5-1-4 Baseline Ramp Layout

****ON A/C A380-800F Models**

Baseline Ramp Layout

1. This section gives the typical ramp layout - cargo aircraft servicing.

**ON A/C A380-800F Models

AC: AIR COND UNIT
 AIR: AIR START UNIT
 CONVEYOR: CONVEYOR BELT
 FUEL: FUEL HYDRANT DISPENSER
 GPU: GROUND POWER UNIT

LV: LAVATORY VEHICLE
 PL: PALLET/CONTAINER LOADER
 PS: PASSENGER STAIRS
 TOW: TOWING TRACTOR
 WV: POTABLE WATER VEHICLE

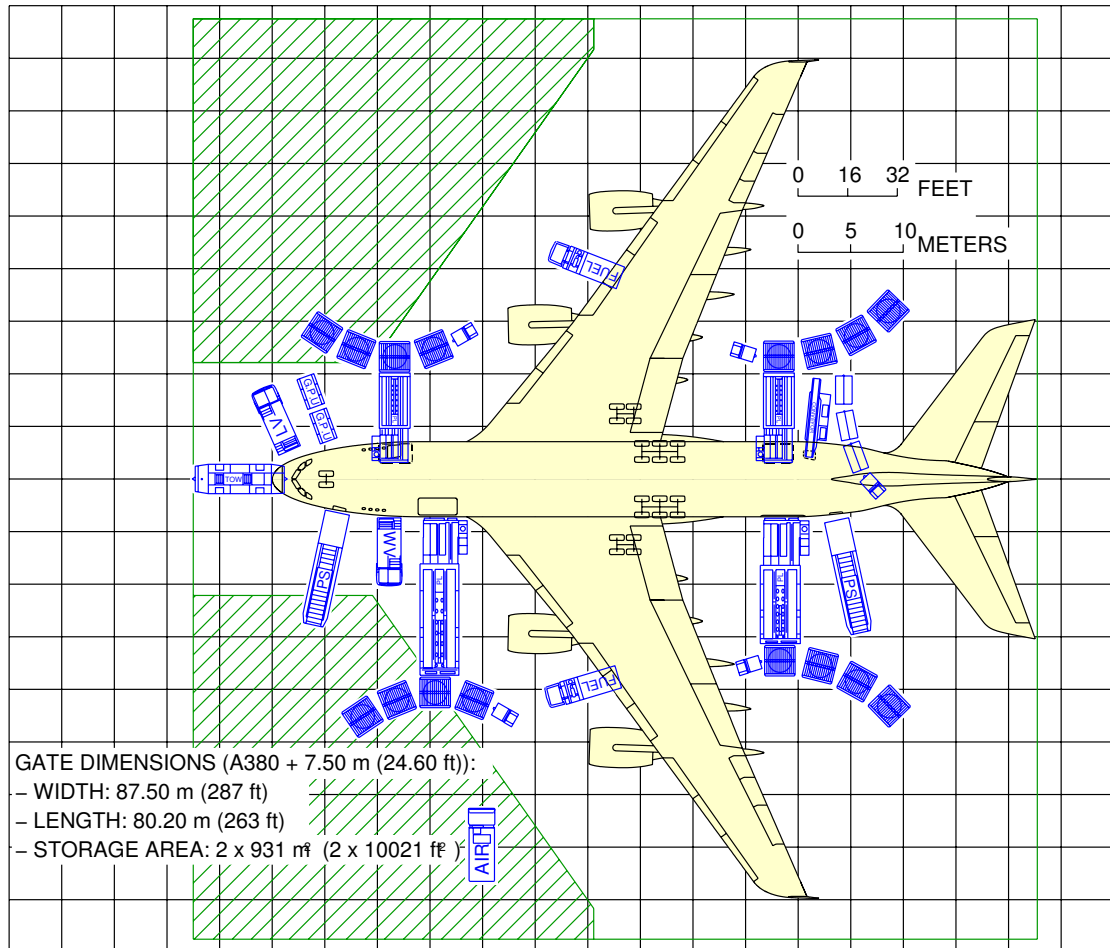

RL04/B1/800F/STD

L_AC_050104_1_0010101_01_00

Baseline Ramp Layout

5-2-0 Terminal Operation - Passenger Aircraft****ON A/C A380-800 Models**Terminal Operation - Passenger Aircraft

1. This section provides typical turn-round time charts showing the typical times for ramp activities during aircraft turn-round.

Actual times may vary due to each operator's specific practice and operating conditions.

For each turn-round time chart, the associated typical ramp layout is given in section 5-1.

2. ASSUMED TURN-ROUND TIME PARAMETERS

- A. PASSENGER BOARDING/DEBOARDING (PB/D) → 100% (555 pax) passenger exchange :

- Doors (type A - 42" wide) used : M1L and M2L (main deck) and U1R (upper deck).
- PB/D rate : boarding = 15 pax/min / deboarding = 25 pax/min
- Last Pax Seating Allowance (LPS) = + 4 min
- 60" stair flow rate : up-flow = 14 pax/min / down-flow = 18 pax/min

- B. CARGO → Full LD-3 exchange (22 + 16) LD-3 and bulk exchange of 2 000 kg (4 409 lb) :

- LD-3 off-loading/loading times : off-loading = 1.4 min/LD-3 / loading = 1.7 min/LD-3
- Pallet loading times : off-loading = 2.5 min/pallet / loading = 2.9 min/pallet
- bulk off-loading/loading times : off-loading = 9.2 min/t / loading = 10.5 min/t

- C. REFUELLING → Block fuel for Nominal Range through 4 nozzles :

- 261 200 liters (67 364 US gallons) at 40 psi (48 min)
- dispenser positioning or removal = 3 min (fuel truck change) / if any = 5 min

- D. CLEANING → Full cleaning :

- Crew adapted to match catering time

- E. CATERING → Full catering :

- average truck capacity = 30 Full Size Trolley Equivalent (FSTE)
- simultaneous catering and PB/D = not represented
- inbound/outbound FSTE = mixed in the same truck
- FSTE exchange time :

- (1) dedicated door-galley = 1.5 min/FSTE
- (2) cart circulation (1 seat zone) = + 0.5 min/FSTE
- (3) cart circulation (> 1 seat zone) = + 1.0 min/FSTE
- (4) via lift :
 - dedicated door to single lift = 2.0 min/FSTE

F. GROUND HANDLING/SERVICING

- start of operations :
 - (1) bridges = $t_0 = 0$
 - (2) others = $t_0 + 1$ min
 - vehicle positioning/removal = 2 min (fuel truck excluded)
 - upper deck vehicle positioning/removal = 3 min
 - clearance between GSE = 0.5 m (20 in)
 - Ground Power Unit (GPU) = up to 4×90 kVA
 - air conditioning = two carts
 - potable water (standard/option) = 1 700/2 500 liters (495/660 US gal) at 60 l/min (23 US gal/min).
 - waste water = discharge and rinsing
 - dollies per tractor = 4 to 6



AIRPLANE CHARACTERISTICS

5-2-1 Typical Turn-Round Time - Two Bridges - Standard Servicing Via Main Deck and Upper Deck

****ON A/C A380-800 Models**

Typical Turn-Round Time - Two Bridges - Standard Servicing Via Main Deck and Upper Decks

1. Typical Turn-Round Time - Two Bridges - Servicing via Main Deck and Upper Decks

**ON A/C A380-800 Models

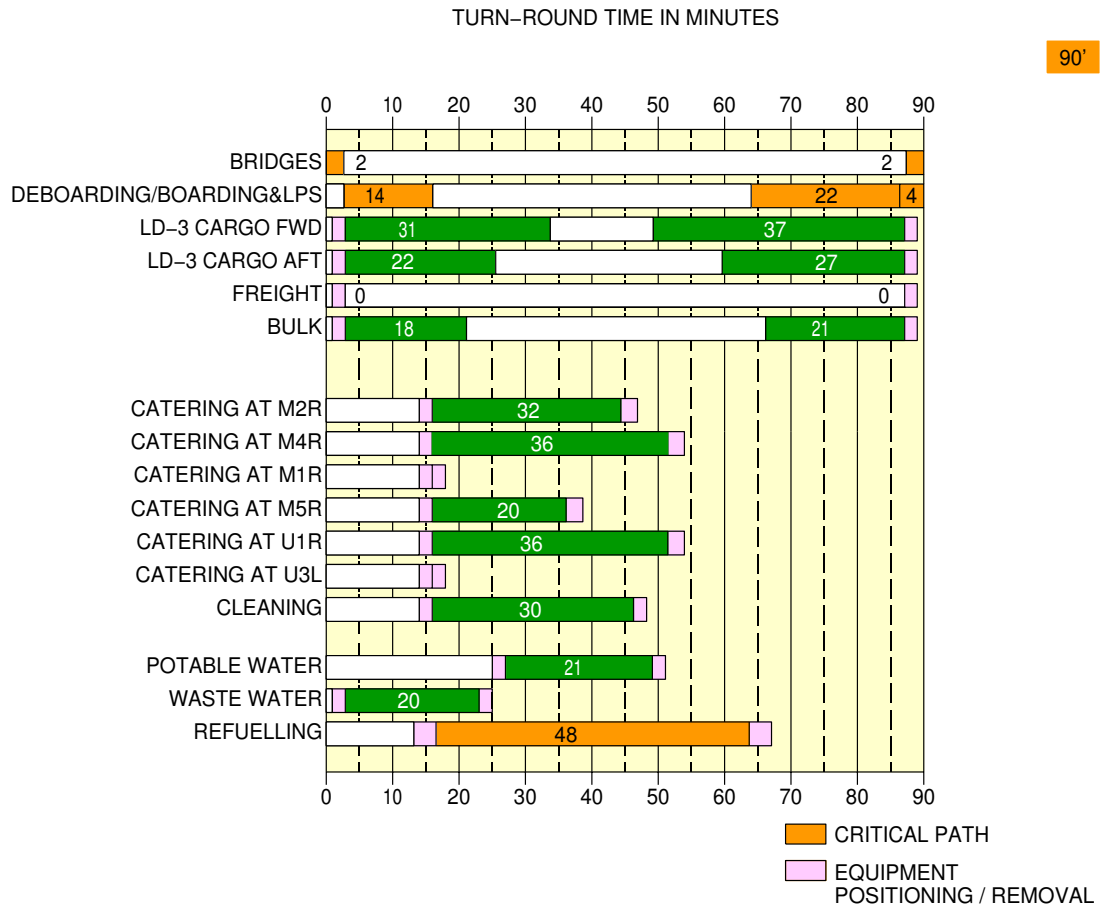

DB1A

L_AC_050201_1_0020101_01_00

Typical Turn-Round Time – Two Bridges
Servicing Via Main and Upper Decks



AIRPLANE CHARACTERISTICS

5-2-2 Typical Turn-Round Time - Two Bridges - Servicing Via Main Deck

****ON A/C A380-800 Models**

Typical Turn-Round Time - Two Bridges - Servicing Via Main Deck

1. Typical Turn-Round Time - Two Bridges - Servicing via Main Deck



AIRPLANE CHARACTERISTICS

**ON A/C A380-800 Models

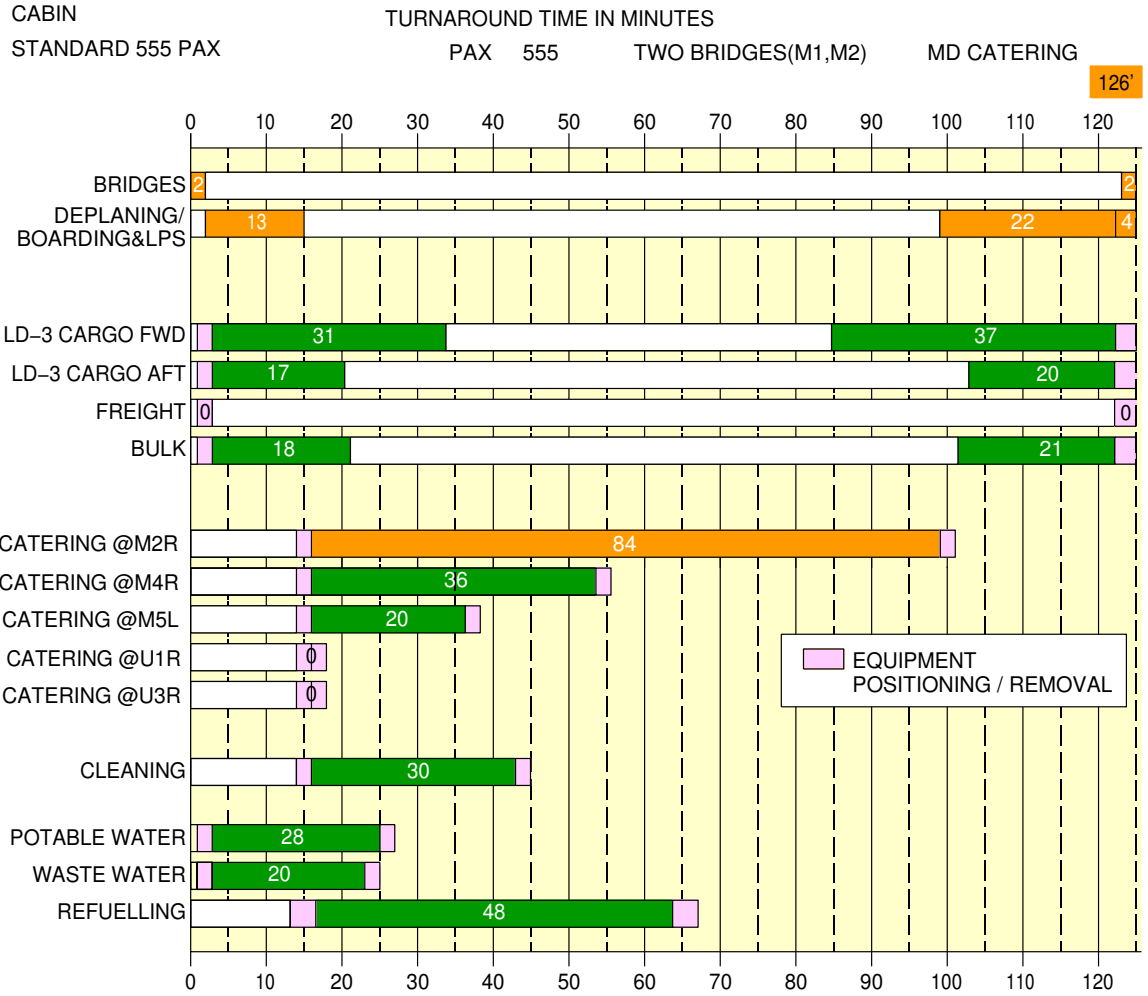

L_AC_050202_1_0010101_01_00

Typical Turn-Round Time – Two Bridges
Servicing Via Main Deck



AIRPLANE CHARACTERISTICS

5-3-0 Terminal Operation - Cargo Aircraft

**ON A/C A380-800F Models

Terminal Operation - Cargo Aircraft

1. Terminal Operation - Cargo Aircraft



AIRPLANE CHARACTERISTICS

5-3-1 Typical Turn-Round Time

****ON A/C A380-800F Models**

Typical Turn-Round Time

1. The A380-800F can achieve turn-round times of 120 ± 20 minutes depending on ULD layouts on the three decks.

NOTE : These values are similar to other wide-body freighter aircraft in similar operating conditions.



AIRPLANE CHARACTERISTICS

5-4-0 Ground Service Connections

**ON A/C A380-800 Models A380-800F Models

Ground Service Connections

1. Ground Service Connections



AIRPLANE CHARACTERISTICS

5-4-1 Ground Service Connections Layout

****ON A/C A380-800 Models**

Ground Service Connections Layout - Pax

1. This section gives the ground service connections layout.

**ON A/C A380-800 Models

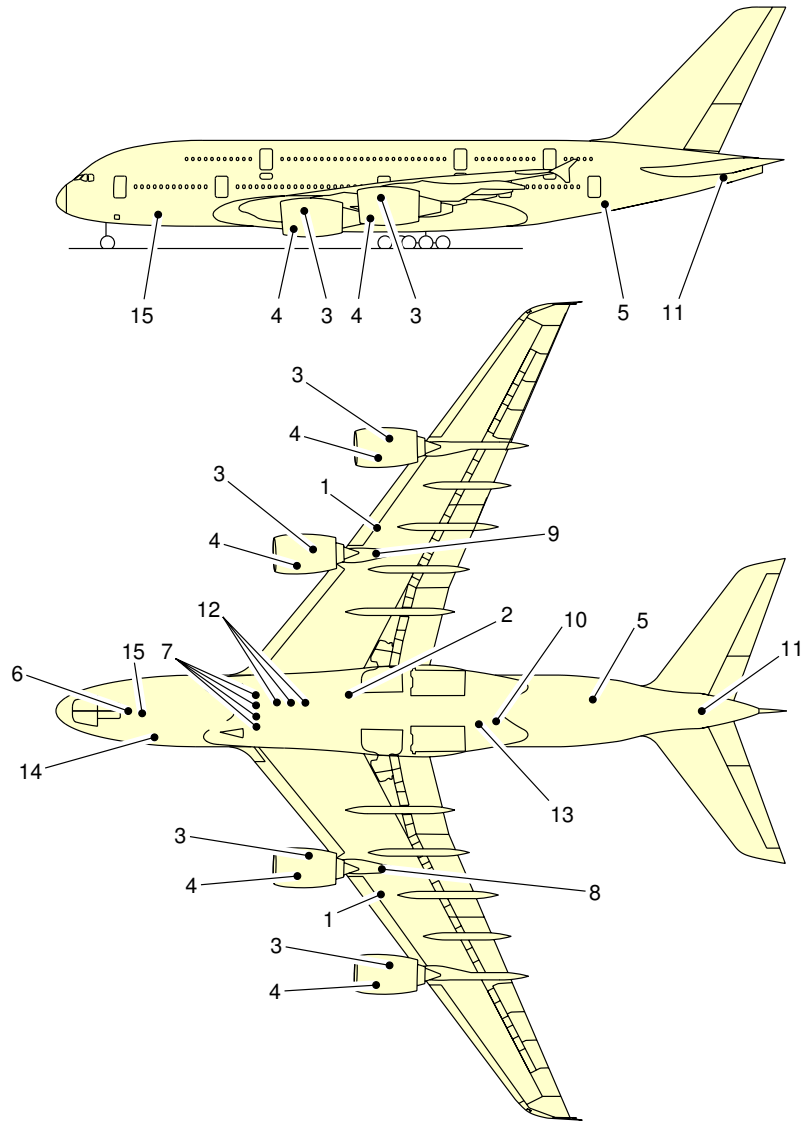

- | | |
|---|---------------------------------------|
| 1 – PRESSURE REFUEL CONNECTORS | 8 – YELLOW HYDRAULIC GROUND CONNECTOR |
| 2 – HYDRAULIC RESERVOIR SERVICING PANEL
(RESERVOIR FILLING AND RESERVOIR PRESSURISATION) | 9 – GREEN HYDRAULIC GROUND CONNECTOR |
| 3 – ENGINE OIL FILLING | 10 – POTABLE WATER SERVICE PANEL |
| 4 – VF GENERATOR OIL FILLING | 11 – APU OIL FILLING |
| 5 – TOILET AND WASTE SERVICE PANEL | 12 – HIGH PRESSURE AIR ENGINE START |
| 6 – GROUND ELECTRICAL POWER | 13 – REFUEL/DEFUEL CONTROL PANEL |
| 7 – LOW PRESSURE PRECONDITIONED AIR | 14 – OXYGEN SYSTEM |
| | 15 – POTABLE WATER DRAIN PANEL |

DB1A

L_AC_050401_1_0010101_01_00

Ground Service Connections Ground Service Connections Layout - A380-800 Models



AIRPLANE CHARACTERISTICS

****ON A/C A380-800F Models**

Ground Service Connections Layout - Freighter

1. This section gives the ground service connections layout.

****ON A/C A380-800F Models**

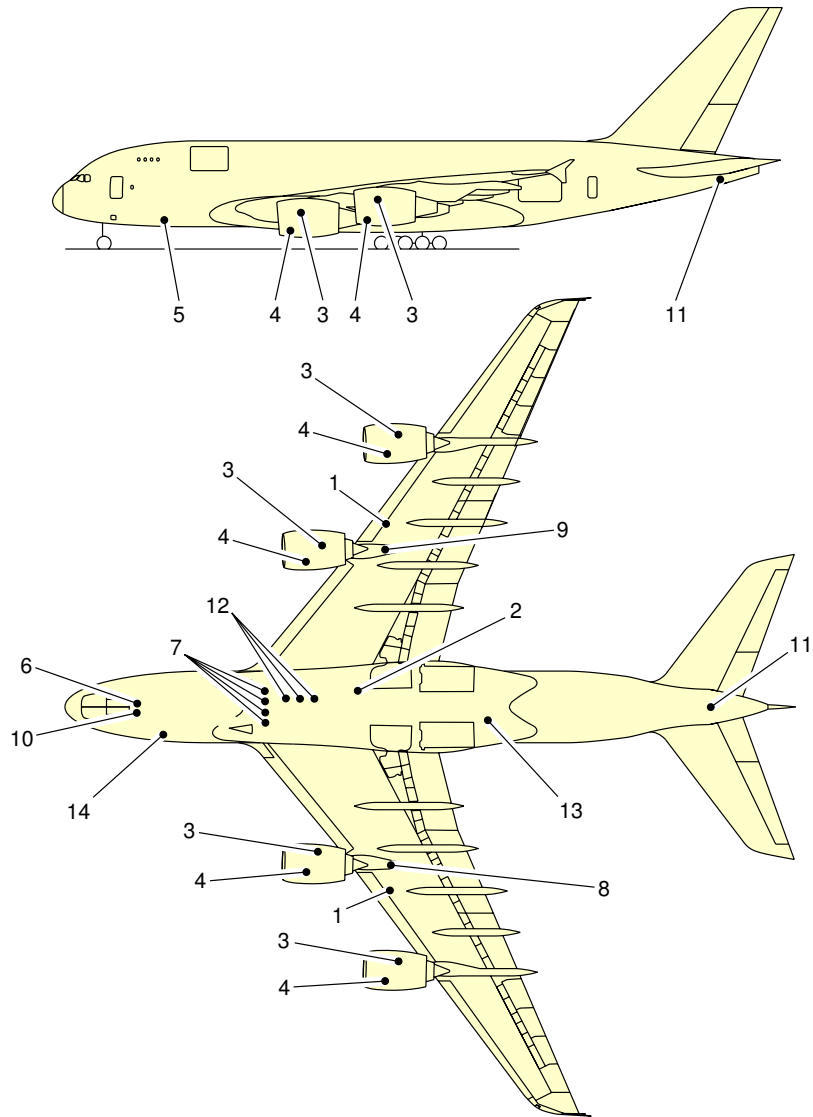

- 1 – PRESSURE REFUEL CONNECTORS
- 2 – HYDRAULIC RESERVOIR SERVICING PANEL
(RESERVOIR FILLING AND RESERVOIR PRESSURISATION)
- 3 – ENGINE OIL FILLING
- 4 – VF GENERATOR OIL FILLING
- 5 – TOILET AND WASTE SERVICE PANEL
- 6 – GROUND ELECTRICAL POWER
- 7 – LOW PRESSURE PRECONDITIONED AIR

- 8 – YELLOW HYDRAULIC GROUND CONNECTOR
- 9 – GREEN HYDRAULIC GROUND CONNECTOR
- 10 – POTABLE WATER SERVICE PANEL
- 11 – APU OIL FILLING
- 12 – HIGH PRESSURE AIR ENGINE START
- 13 – REFUEL/DEFUEL CONTROL PANEL
- 14 – OXYGEN SYSTEM

DB1A

L_AC_050401_1_0030101_01_00

Ground Service Connections Ground Service Connections Layout - A380-800F Models

5-4-2 Grounding Points

****ON A/C A380-800 Models A380-800F Models**

Grounding Points

1. Grounding Points

	DISTANCE: Meters (ft)		
	AFT OF NOSE	FROM AIRPLANE CENTERLINE	MEAN HEIGHT FROM GROUND
On Nose Landing Gear	5.713 (18.7)	0.182 (0.6) On the RH side	1.385 (4.5)
On left Wing Gear leg	34.207 (112.2)	5.949 (19.5)	1.237 (4.0)
On right Wing Gear leg	34.207 (112.2)	5.949 (19.5)	1.237 (4.0)
On left Body Gear leg (Outboard)	37.158 (121.9)	2.852 (9.4)	1.379 (4.5)
On left Body Gear leg (Inboard)	37.158 (121.9)	2.412 (7.9)	1.379 (4.5)
On right Body Gear leg (Outboard)	37.158 (121.9)	2.852 (9.4)	1.379 (4.5)
On right Body Gear leg (Inboard)	37.158 (121.9)	2.412 (7.9)	1.379 (4.5)

- A. The grounding stud on each landing gear is designed for use with a clip-on connector, such as an Appleton TGR.
- B. The grounding studs are used to connect the airplane to approved ground connection on the ramp or in the hangar for:
 - (1) refuel/defuel operations
 - (2) maintenance operations
 - (3) bad weather conditions.

**ON A/C A380-800 Models A380-800F Models

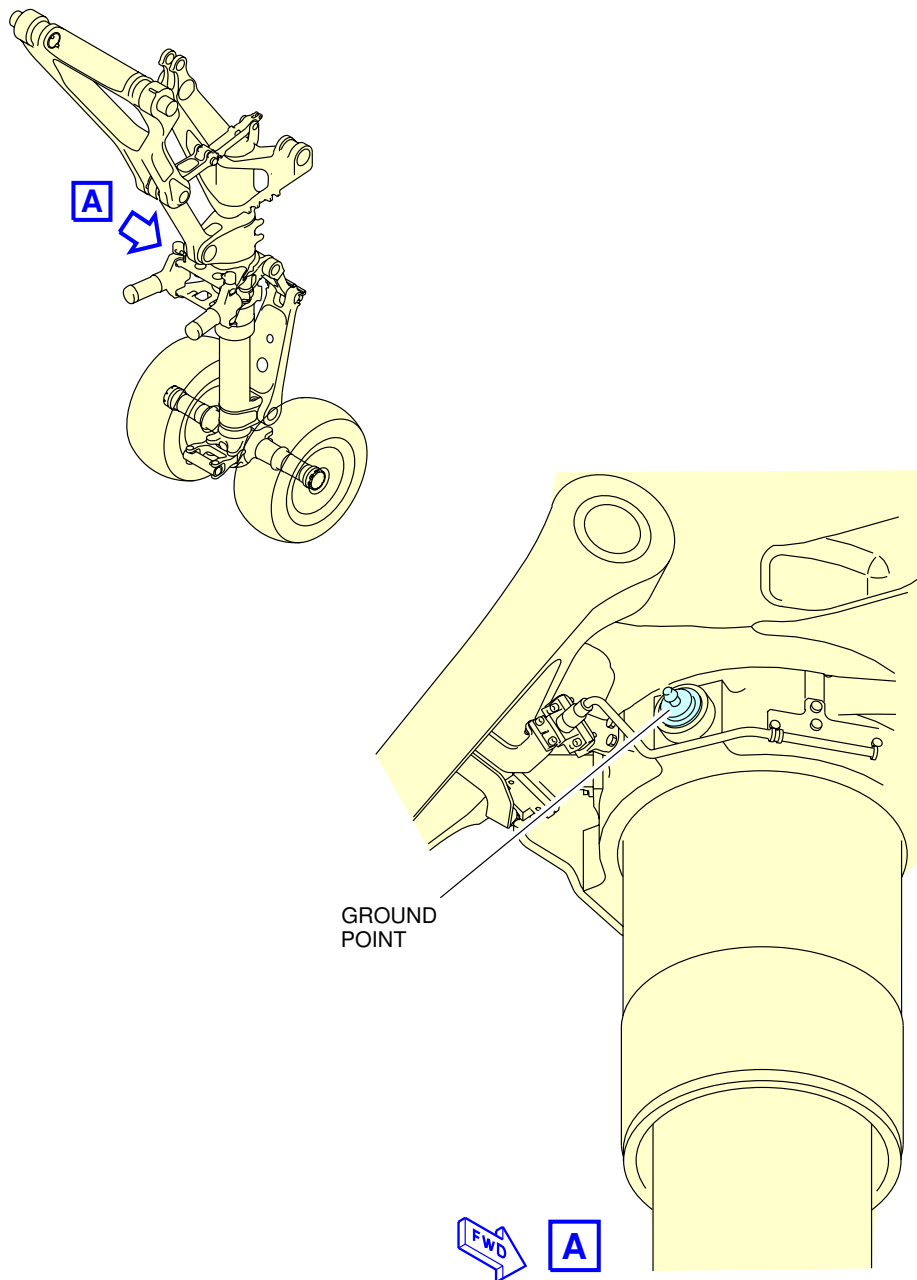

L_AC_050402_1_0010101_01_00

Ground Points NLG

**ON A/C A380-800 Models A380-800F Models

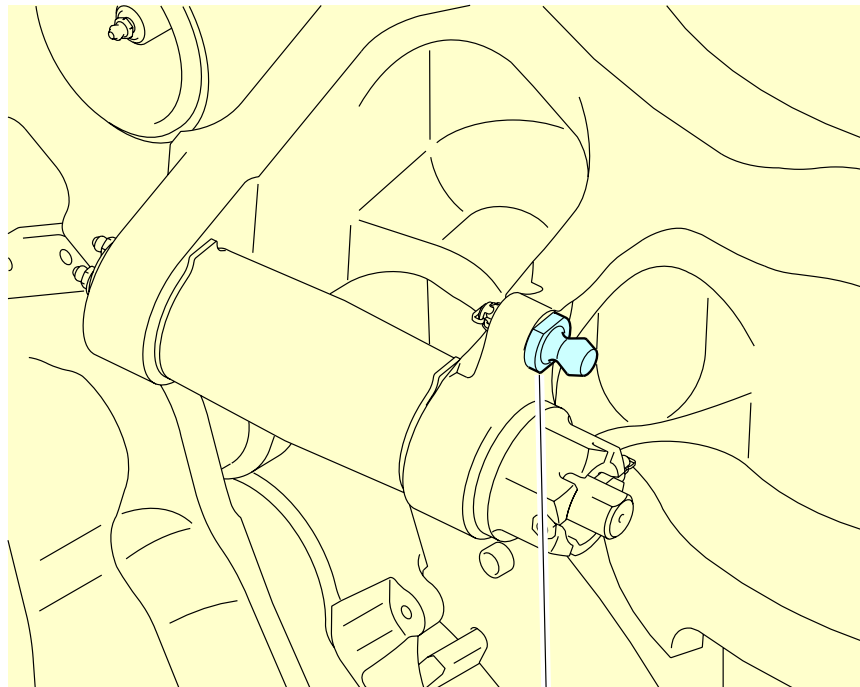
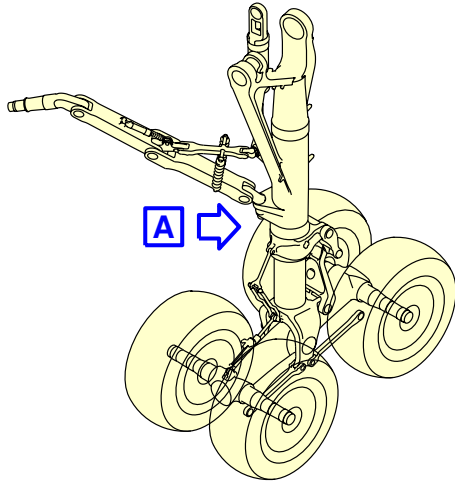

GROUND POINT

L_AC_050402_1_0020101_01_00

Ground Point WLG

**ON A/C A380-800 Models A380-800F Models

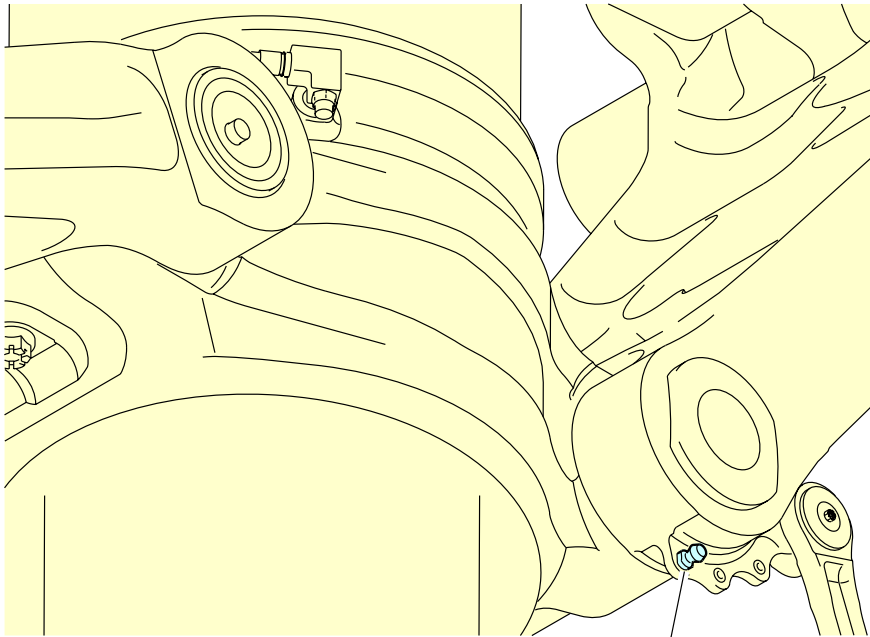
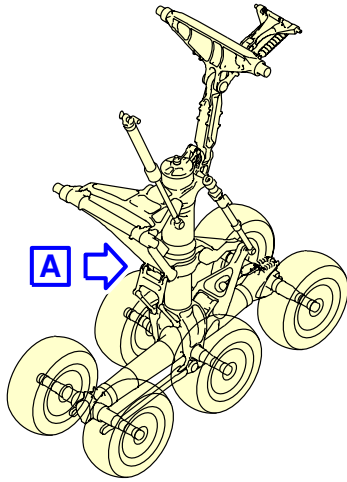

GROUND POINTS
(RIGHT ONE SHOWN LEFT ONE SIMILAR)

L_AC_050402_1_0030101_01_00

Ground Points BLG

5-4-3 Hydraulic System

****ON A/C A380-800 Models A380-800F Models**

Hydraulic System

1. Door Location

	DISTANCE : Meters (ft)			
	AFT OF NOSE	FROM AIRPLANE CENTERLINE		MEAN HEIGHT FROM GROUND
		R SIDE	L SIDE	
- Green hydraulic ground connectors : (Access door 469FL)	34.67 (113.7)		14.90 (48.88)	5.08 (16.66)
- Yellow hydraulic ground connector : (Access door 479FL)	34.67 (113.7)	14.90 (48.88)		5.08 (16.66)
- Hydraulic Reservoir Servicing Panel : (Access door 197CB)	31.89 (104.63)		2.34 (7.67)	1.71 (5.61)

A. Reservoir Pressurization

(1) One connector ETRTO V0.09.6, 1/4 in.

B. Reservoir Filling

(1) One connector AE96993E, 1/4 in.

**ON A/C A380-800 Models A380-800F Models

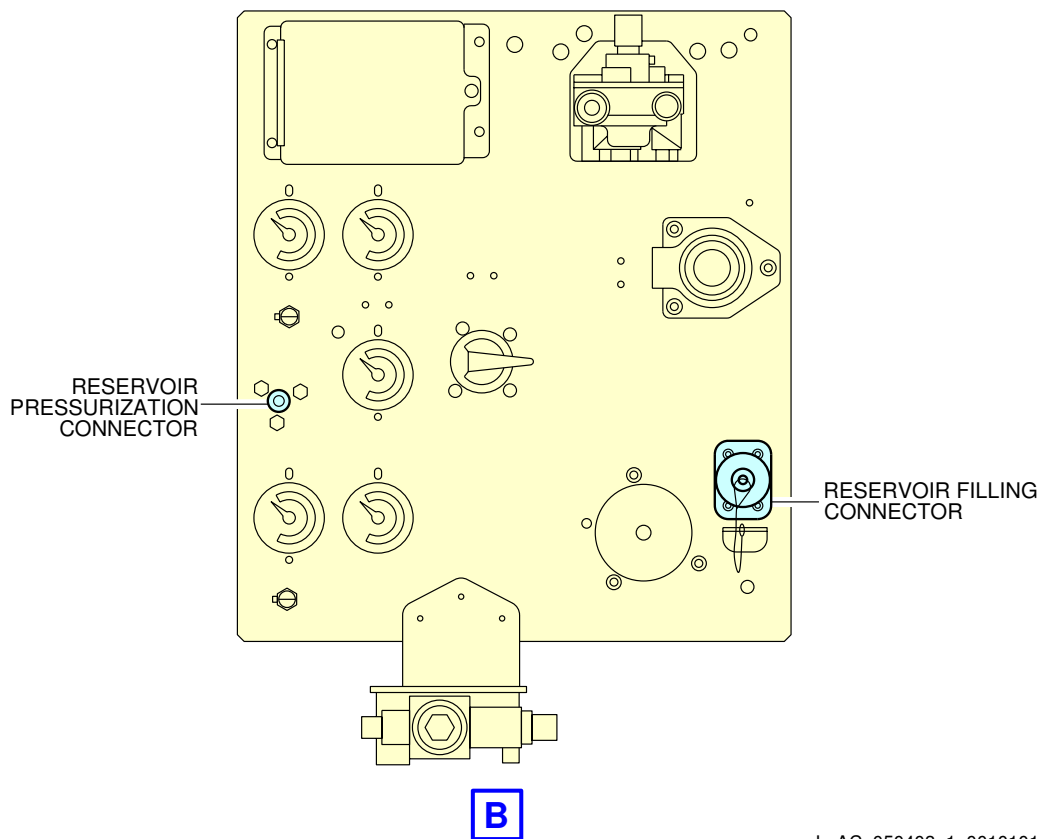
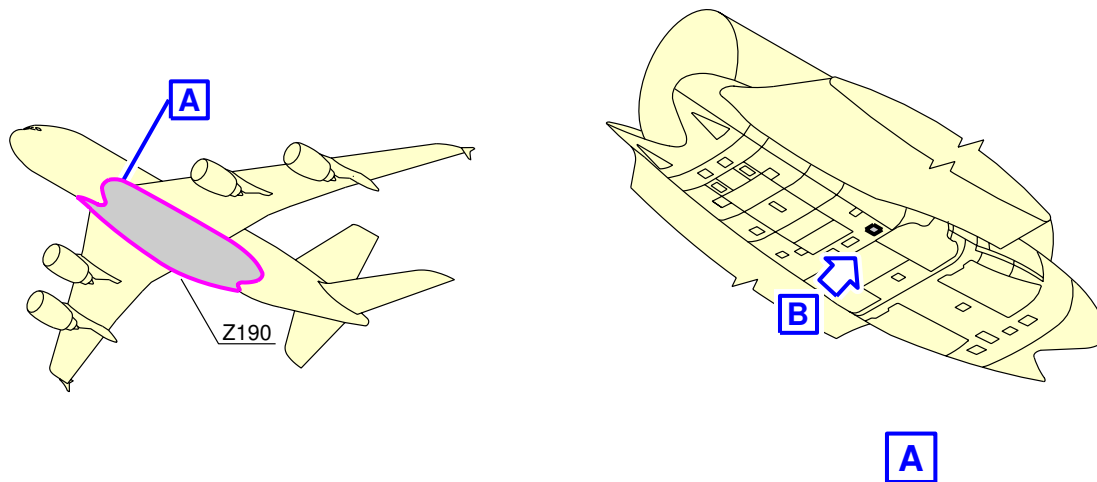

L_AC_050403_1_0010101_01_00

Ground Service Connections
Hydraulic Reservoir Servicing Panel

**ON A/C A380-800 Models A380-800F Models

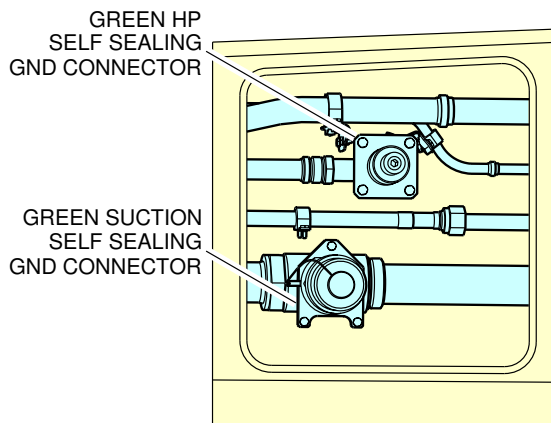
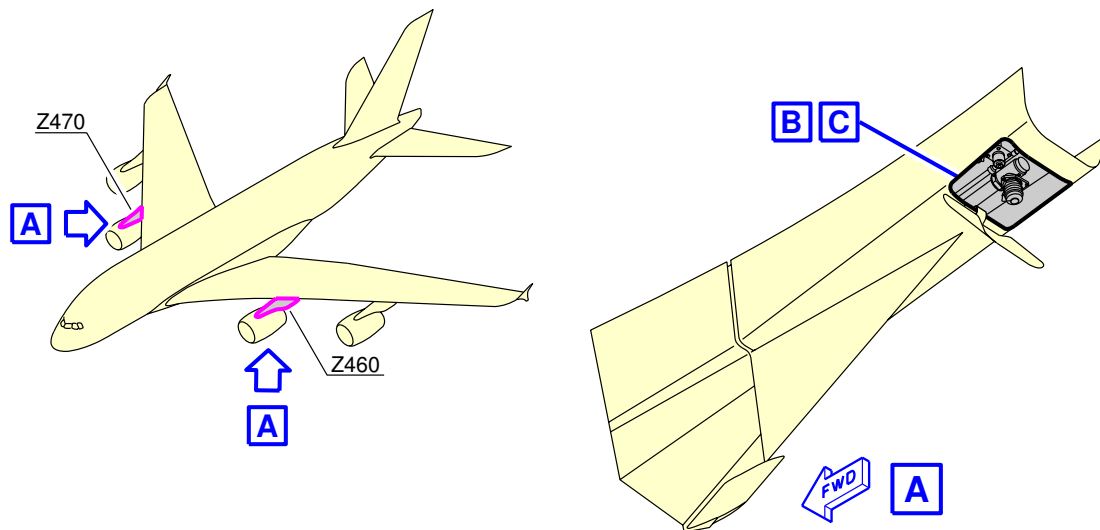

B

FOR LH PYLON

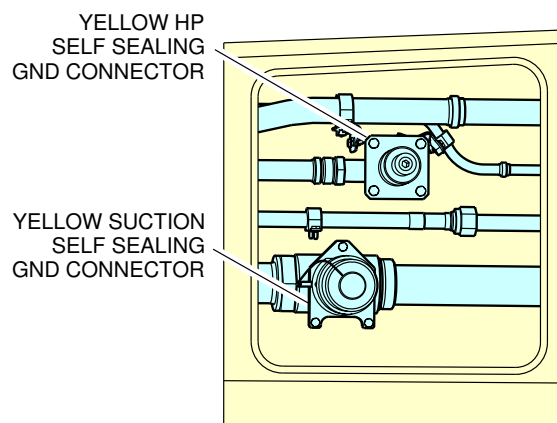

C

FOR RH PYLON

L_AC_050403_1_0020101_01_00

Ground Service Connections
Hydraulic Ground Connections

5-4-4 Electrical System

****ON A/C A380-800 Models**Electrical System - Pax

1. Electrical System

	DISTANCE : Meters (ft)			
	AFT OF NOSE	FROM AIRPLANE CENTERLINE		MEAN HEIGHT FROM GROUND
		R SIDE	L SIDE	
- Right side access door : 134AR	5.99 (19.65)	0.45 (1.47)		2.59 (8.49)
- Left side access door : 133AL	5.99 (19.65)		0.45 (1.47)	2.59 (8.49)

A. External Power Receptacles :

(1) four standard ISO R461 receptacles - 90 KVA each.

B. Power supply :

(1) three phase, 115V, 400 Hz.

C. Electrical connectors for servicing :

(1) AC outlets : HUBBEL 5258

(2) DC outlets : HUBBEL 7472

(3) Vacuum cleaner outlets : HUBBEL 5258

**ON A/C A380-800 Models

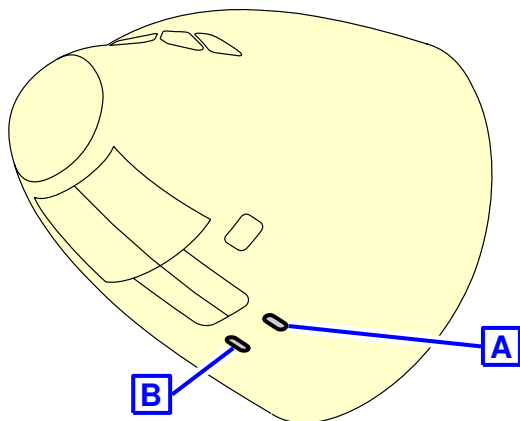

EXTERNAL POWER RECEPTABLES

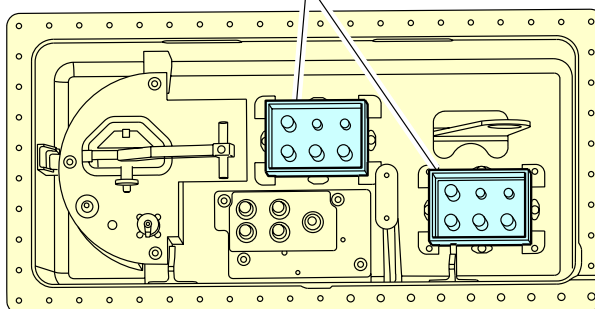

A

EXTERNAL POWER RECEPTABLES

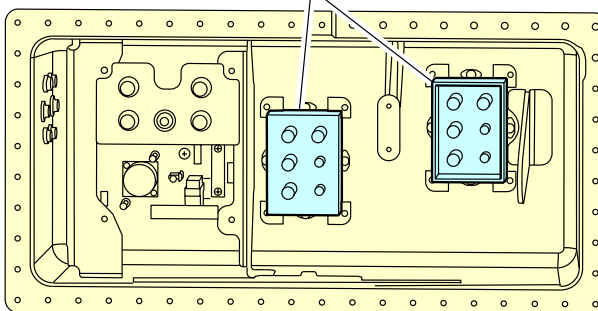

B

L_AC_050404_1_0010101_01_00

Ground Service Connections
Electrical Service Panel - A380-800 Models

****ON A/C A380-800F Models**

Electrical System - Freighter

1. Electrical System

	DISTANCE : Meters (ft)			
	AFT OF NOSE	FROM AIRPLANE CENTERLINE		MEAN HEIGHT FROM GROUND
		R SIDE	L SIDE	
- access door : TBD	5.99 (19.65)		0.45 (1.47)	2.59 (8.49)

A. External Power Receptacles :

(1) four standard ISO R461 receptacles - 90 KVA each.

B. Power supply :

(1) three phase, 115V, 400 Hz.

C. Electrical connectors for servicing :

(1) AC outlets : HUBBEL 5258

(2) DC outlets : HUBBEL 7472

**ON A/C A380-800F Models

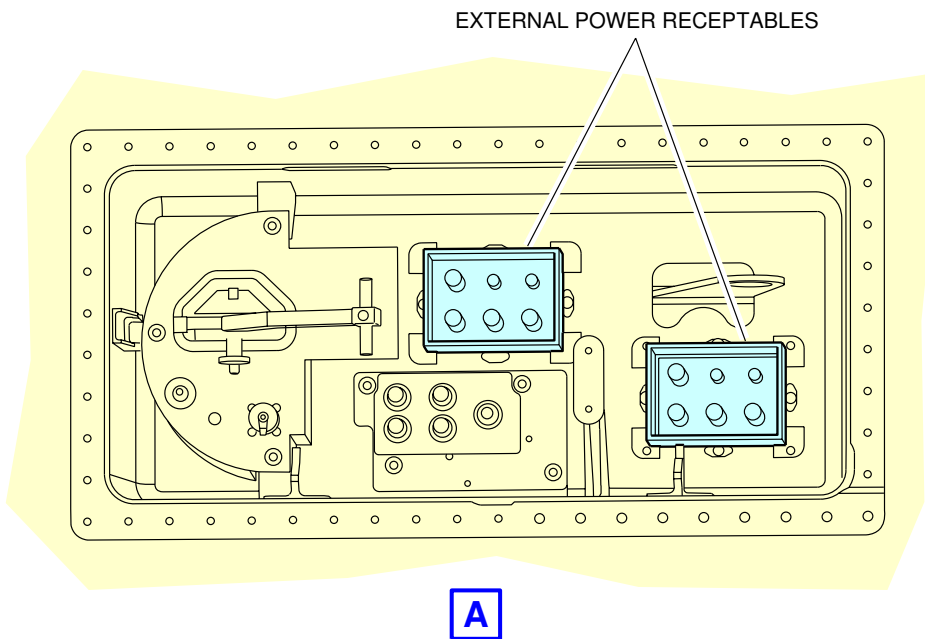
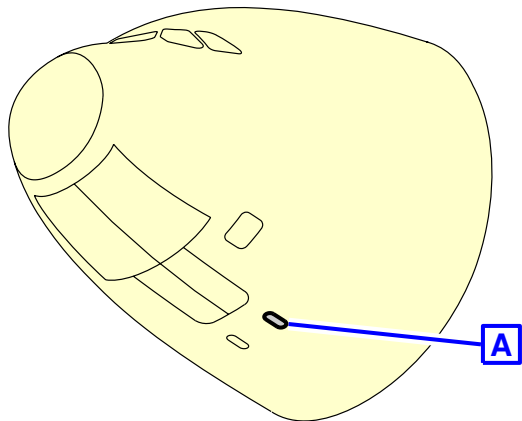

L_AC_050404_1_0030101_01_00

Ground Service Connections
Electrical Service Panel - A380-800F Models

5-4-5 Oxygen System

****ON A/C A380-800 Models A380-800F Models**Oxygen System

1. Door Location

NOTE : INTERNAL CHARGING CONNECTION PROVIDED

	DISTANCE : Meters (ft)			
	AFT OF NOSE	FROM AIRPLANE CENTERLINE		MEAN HEIGHT FROM GROUND
		R SIDE	L SIDE	
- Access door : 272AFZ	7.45 (24.44)	2.23 (7.32)		3.25 (10.66)

Zero, one or two service connections (external charging in the avionics compartment) MS22066 Std

**ON A/C A380-800 Models A380-800F Models

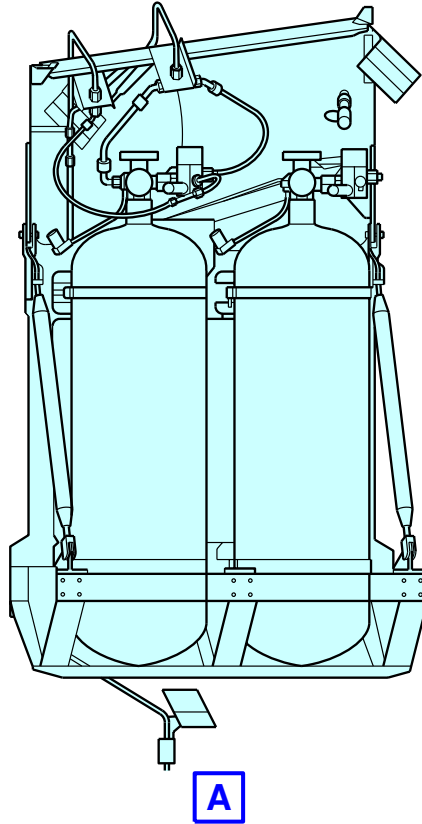
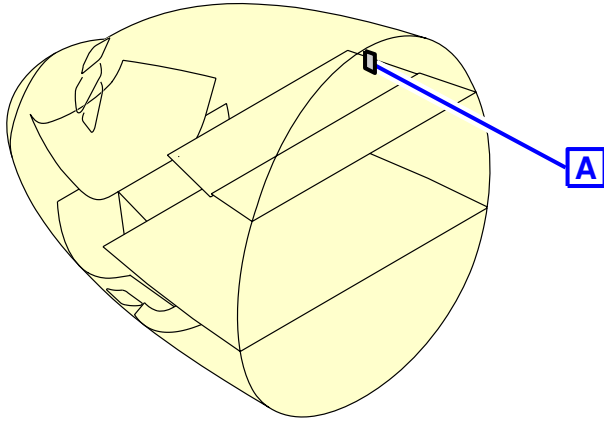

L_AC_050405_1_0010101_01_00

Ground Service Connections
Oxygen System

5-4-6 Fuel System

****ON A/C A380-800 Models A380-800F Models**

Fuel System

1. Refuel/Defuel Control Panel

	DISTANCE : Meters (ft)			
	AFT OF NOSE	FROM AIRPLANE CENTERLINE		MEAN HEIGHT FROM GROUND
		R SIDE	L SIDE	
- Refuel/Defuel control panel : (Access door 199KB)	48 (159.48)	0.68 (2.23)		1.98 (6.50)

2. Refuel/Defuel Connectors

	DISTANCE : Meters (ft)			
	AFT OF NOSE	FROM AIRPLANE CENTERLINE		MEAN HEIGHT FROM GROUND
		R SIDE	L SIDE	
- refuel/defuel coupling, left: (Access door 522GB)	31.89 (104.62)		17.97 (58.95)	5.94 (19.49)
- refuel/defuel coupling, right: (Access door 622GB)	31.89 (104.62)	17.97 (58.95)		5.94 (19.49)

A. Refuel/Defuel couplings :

- (1) Standard ISO R45, 2.5 in., two per wing

B. Refuel pressure :

- (1) Max. pressure : 3.45 bar (50 psi)

**ON A/C A380-800 Models A380-800F Models

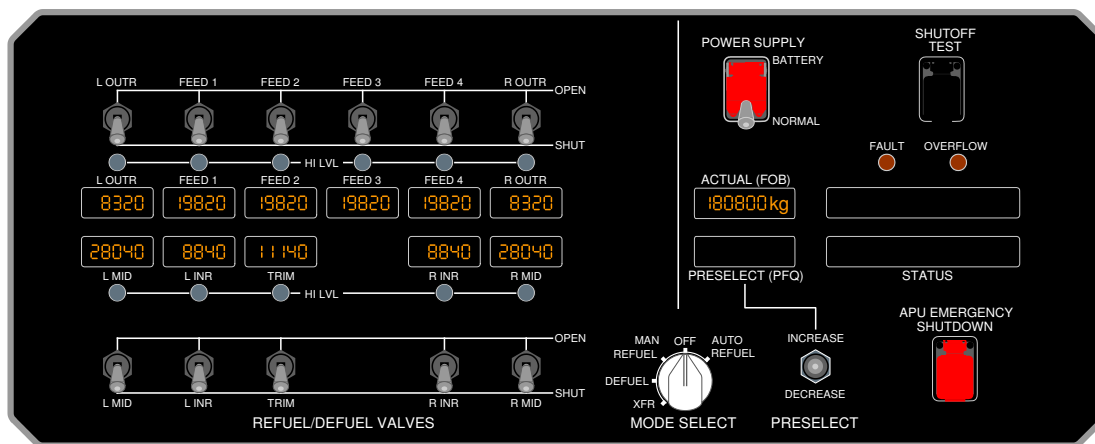
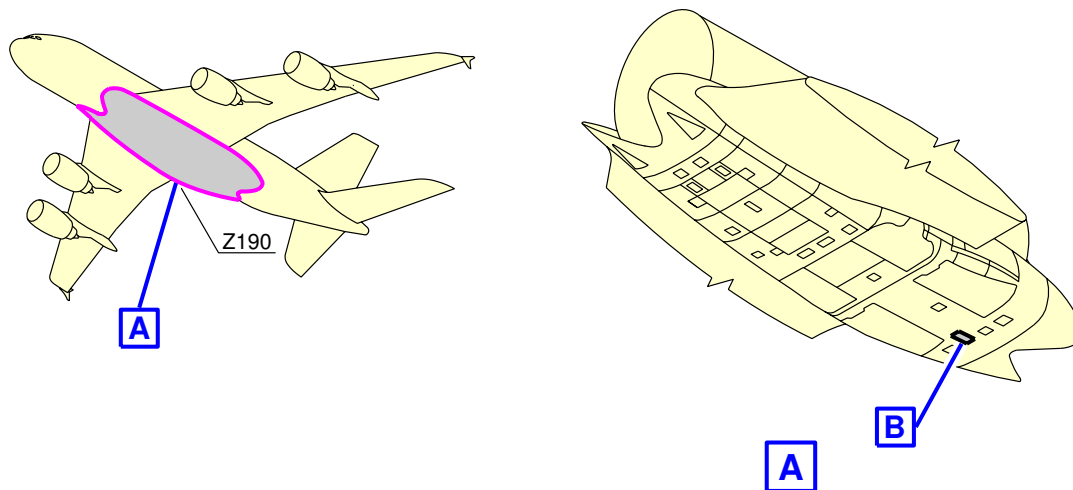

42QU

B

L_AC_050406_1_0010101_01_00

Ground Service Connections
Refuel/Defuel Control Panel

**ON A/C A380-800 Models A380-800F Models

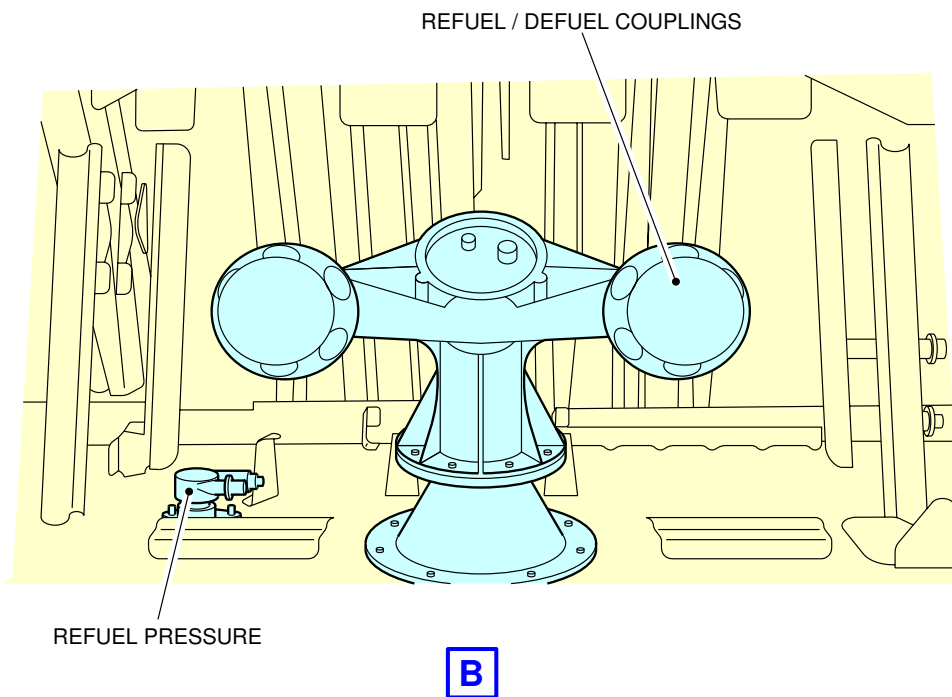
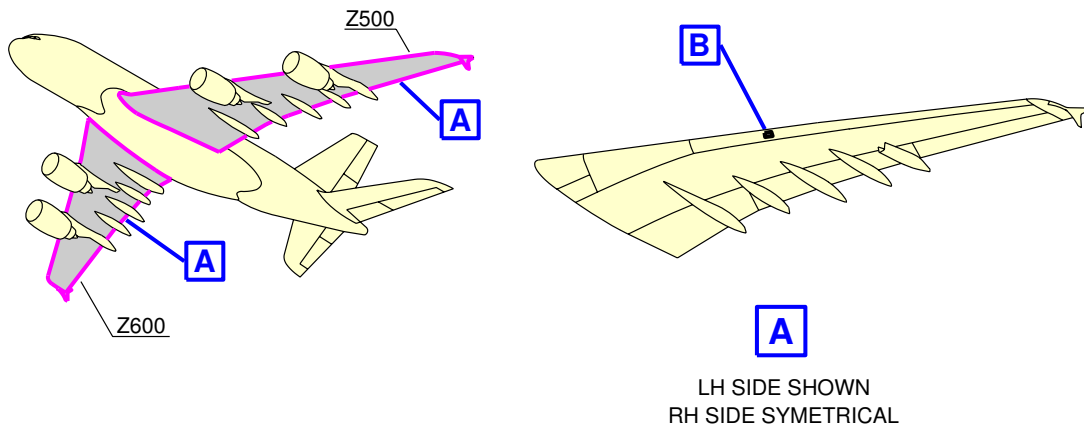

L_AC_050406_1_0020101_01_00

Ground Service Connections
Pressure Refuel Connections

5-4-7 Pneumatic System

****ON A/C A380-800 Models A380-800F Models**

Pneumatic System

1. Low Pressure Connectors

	DISTANCE : Meters (ft)			
	AFT OF NOSE	FROM AIRPLANE CERNTERLINE		MEAN HEIGHT FROM GROUND
		R SIDE	L SIDE	
access doors 191GB	21.85 (71.69)		1.24 (4.07)	2.08 (6.82)
access doors 191JB	22.36 (73.36)		1.76 (5.77)	2.08 (6.82)
access doors 191HB	21.85 (71.69)	1.24 (4.07)		2.08 (6.82))
access doors 191KB	22.36 (73.36)	1.76 (5.77)		2.08 (6.82)

A. Connectors :

- (1) Four standard MS33562 (ISO1034), 8 in.

2. High Pressure Connectors

	DISTANCE : Meters (ft)			
	AFT OF NOSE	FROM AIRPLANE CERNTERLINE		MEAN HEIGHT FROM GROUND
		R SIDE	L SIDE	
- access doors 193BB	25.37 (83.23)		0.2 (0.66)	1.78 (5.84)

A. Connectors :

- (1) Three standard MS33740 (ISO2026), 3 in.

**ON A/C A380-800 Models A380-800F Models

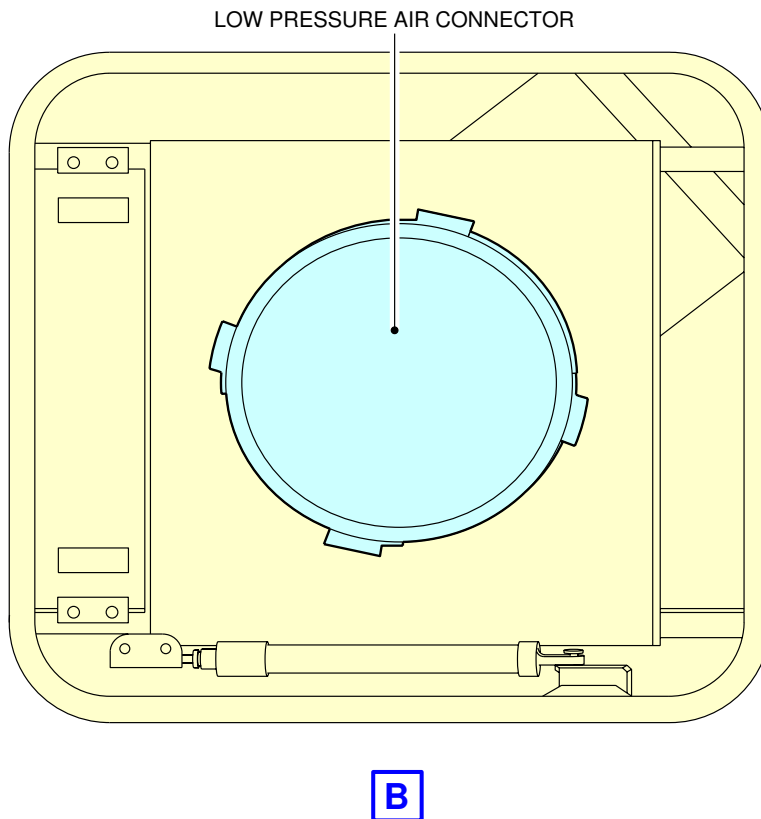
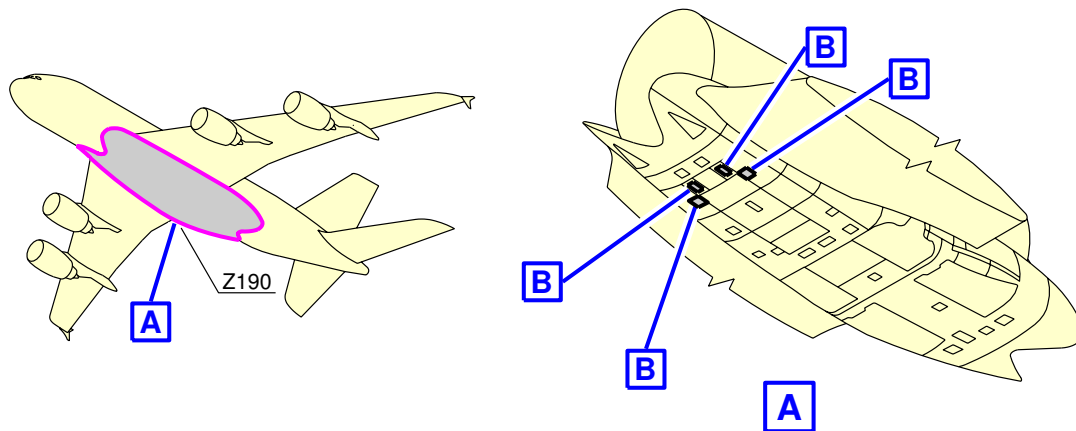

L_AC_050407_1_0010101_01_00

Ground Service Connections
Low Pressure Preconditioned Air

**ON A/C A380-800 Models A380-800F Models

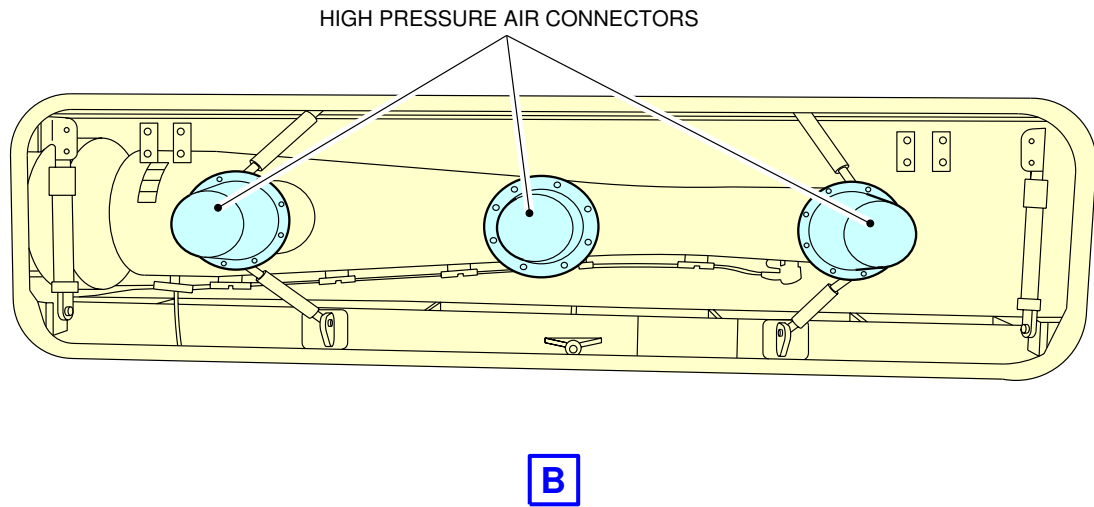
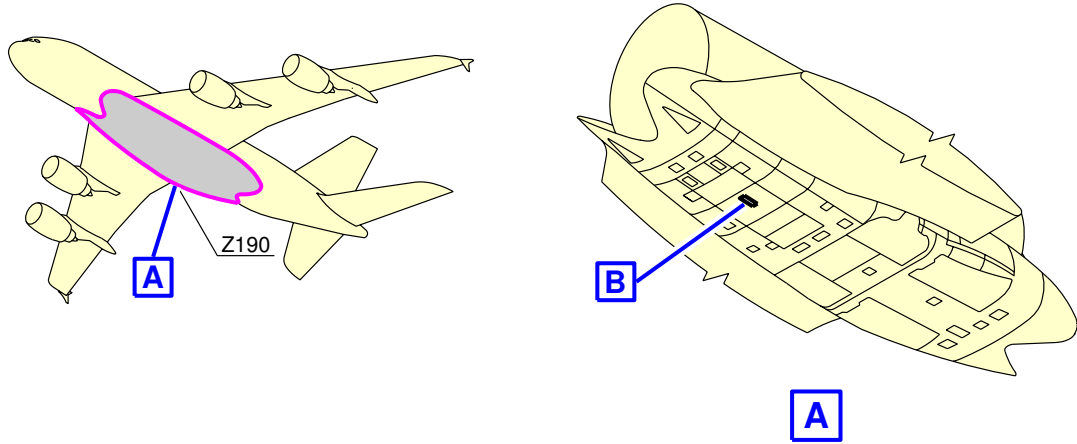

L_AC_050407_1_0020101_01_00

Ground Service Connections
High Pressure Preconditioned Air

5-4-8 Potable Water System

****ON A/C A380-800 Models**

Potable Water System - Pax

1. Potable Water System

	DISTANCE : Meters (ft)			
	AFT OF NOSE	FROM AIRPLANE CENTERLINE		MEAN HEIGHT FROM GROUND
		R SIDE	L SIDE	
- Potable water ground service panel: access door 199NB	43.67 (143.27)		0.37 (1.21)	2.18 (7.15)
- Potable water drain panel: access door 133BL	9.83 (32.25)		0.3 (0.98)	2.74 (8.99)

A. Connectors :

- (1) Fill/Drain Nipple, 3/4 in.

B. Capacity :

- (1) Standard configuration - six tanks : 1700 l (449 USgal)
- (2) Optional : 2266 l (598 USgal)

C. Filling pressure :

- (1) Max Filling Pressure: 8.6 bar (125 psi)

**ON A/C A380-800 Models

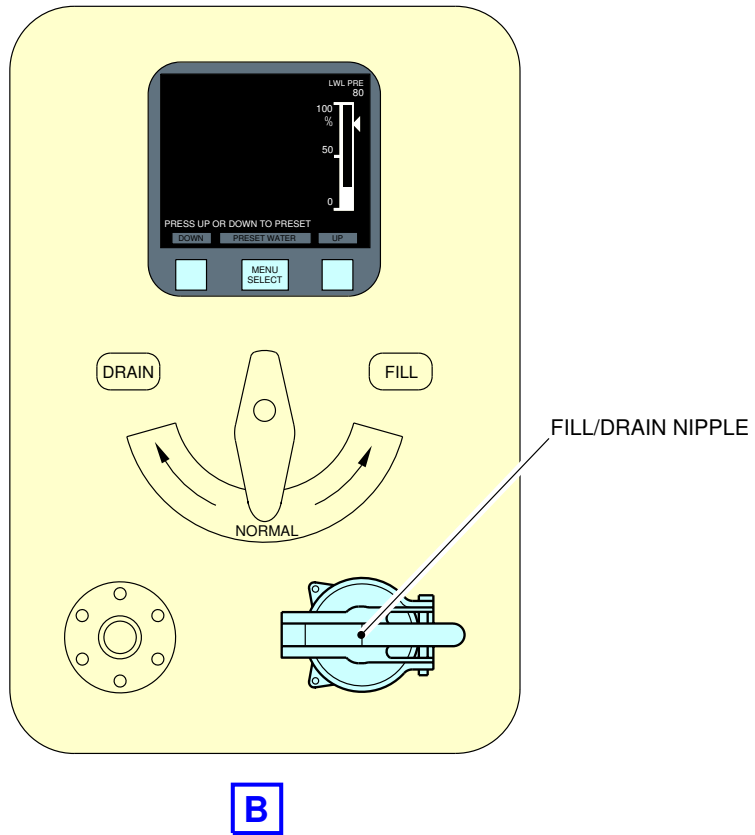
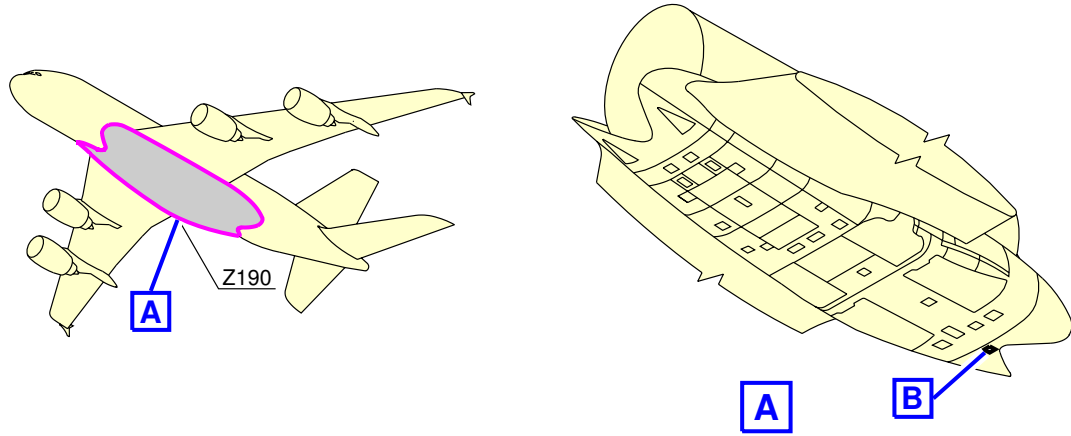

L_AC_050408_1_0010101_01_00

Ground Service Connections
Potable Water Ground Service Panel - A380-800 Models

**ON A/C A380-800 Models

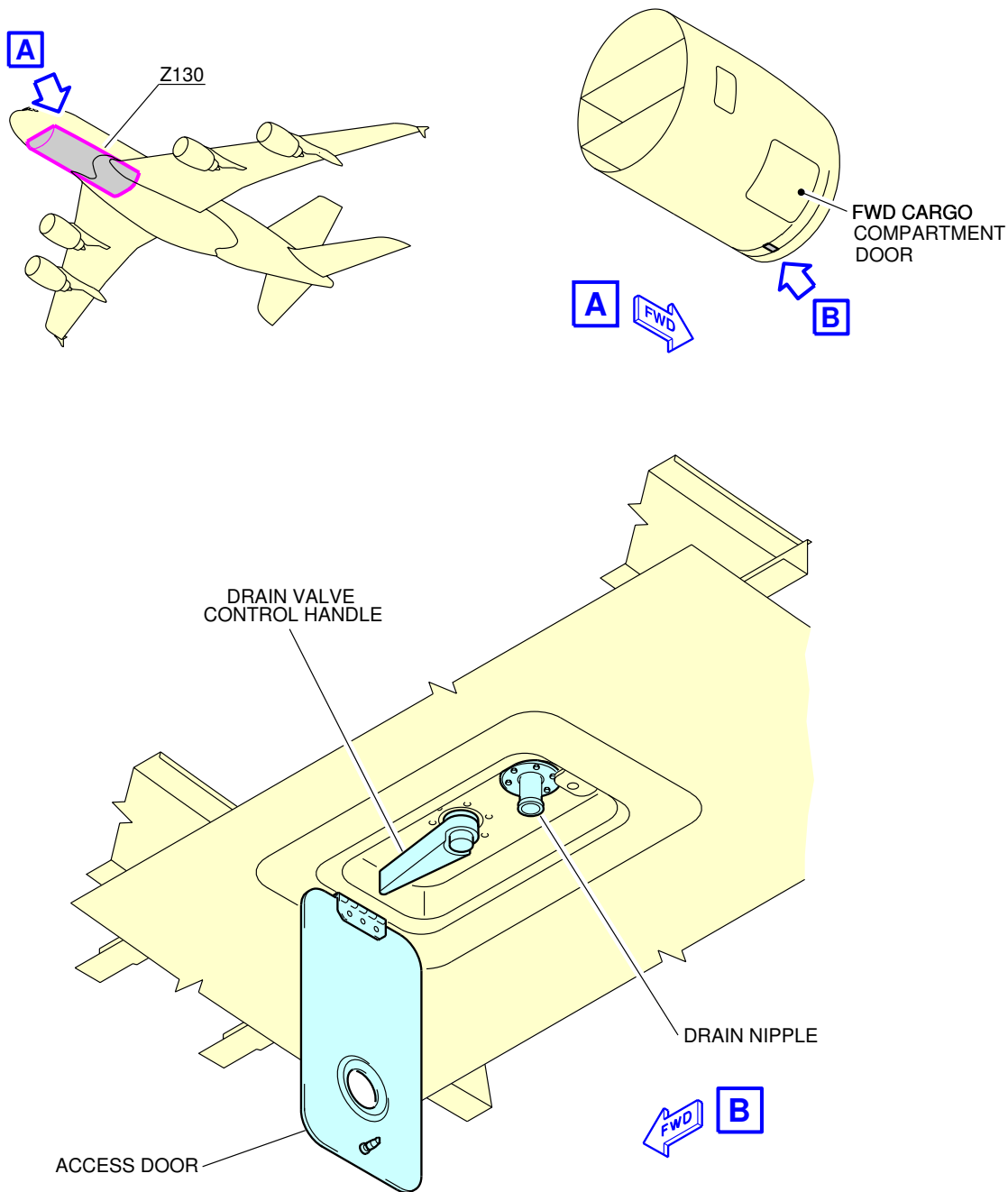

L_AC_050408_1_0040101_01_00

Ground Service Connections
Potable Water Drain Panel - A380-800 Models

****ON A/C A380-800F Models**Potable Water System - Freighter

1. Potable Water System

	DISTANCE : Meters (ft)			MEAN HEIGHT FROM GROUND
	AFT OF NOSE	FROM AIRPLANE CENTERLINE		
		R SIDE	L SIDE	
- access door TBD	5.99 (19.65)	0.45 (1.48)		2.59 (8.50)

A. Connectors :

(1) Fill/Drain Nipple, 3/4 in.

B. Capacity :

(1) Standard configuration - one tank : 80 l (21 USgal)

(2) Option available for reservoir of 160 l (42 USgal)

C. Filling pressure :

(1) Max Filling Pressure: 8.6 bar (125 psi)

**ON A/C A380-800F Models

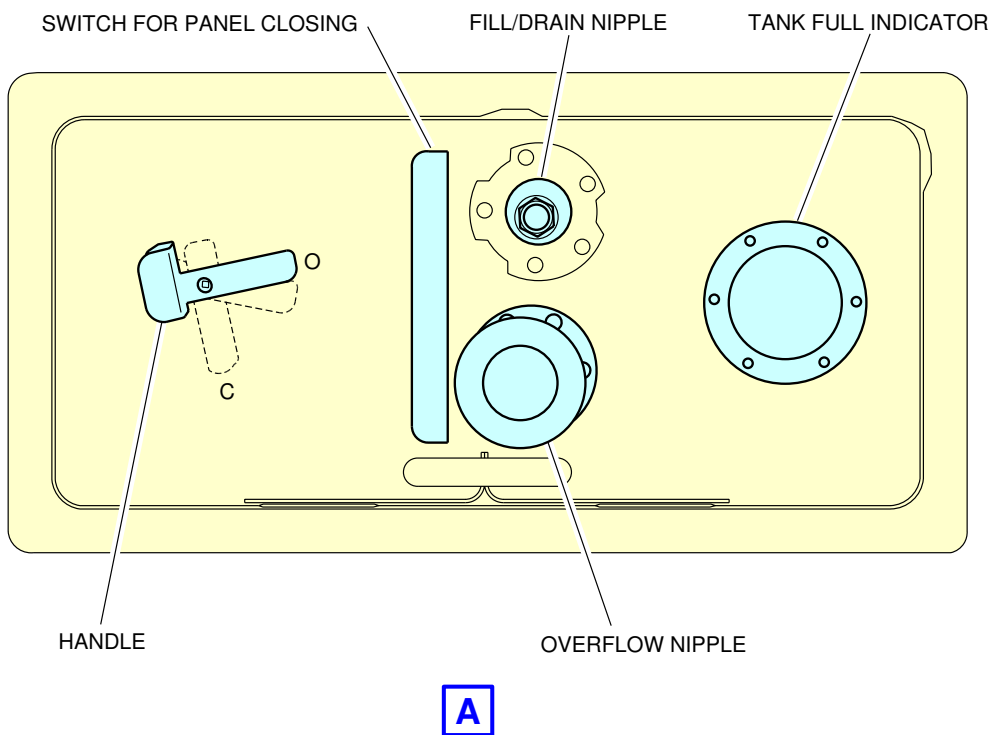
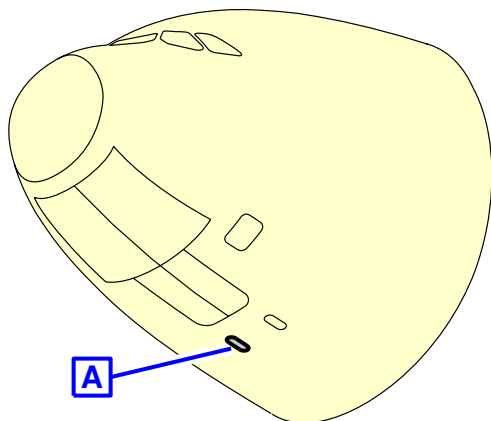

L_AC_050408_1_0030101_01_00

Ground Service Connections
Potable Water Ground Service Panel - A380-800F Models

5-4-9 Oil System

****ON A/C A380-800 Models A380-800F Models**

Engine Oil Servicing

1. Engine Oil Servicing (TRENT900 Engines)

	DISTANCE : Meters (ft)			
	AFT OF NOSE	FROM AIRPLANE CENTERLINE		MEAN HEIGHT FROM GROUND
		R SIDE	L SIDE	
- Engine 1 (access door 416BR)	32.65 (107.12)		23.58 (77.36)	4.24 (13.91)
- Engine 2 (access door 426BR)	24.98 (81.96)		12.74 (41.79)	3.08 (10.10)
- Engine 3 (access door 436BR)	32.65 (107.12)	16.61 (54.49)		3.08 (10.10)
- Engine 4 (access door 446BR)	24.98 (81.96)	27.45 (90.05)		4.24 (13.91)

2. Engine Oil Servicing (GP7200 Engines)

	DISTANCE : Meters (ft)			
	AFT OF NOSE	FROM AIRPLANE CENTERLINE		MEAN HEIGHT FROM GROUND
		R SIDE	L SIDE	
- Engine 1 (access door TBD)	33.03 (108.37)		27.42 (89.96)	4.4 (14.44)
- Engine 2 (access door TBD)	25.35 (83.17)		16.62 (54.53)	3.13 (10.27)
- Engine 3 (access door TBD)	25.35 (83.17)	12.78 (41.93)		3.13 (10.27)
- Engine 4 (access door TBD)	33.03 (108.37)	23.62 (77.49)		4.4 (14.44)

**ON A/C A380-800 Models A380-800F Models

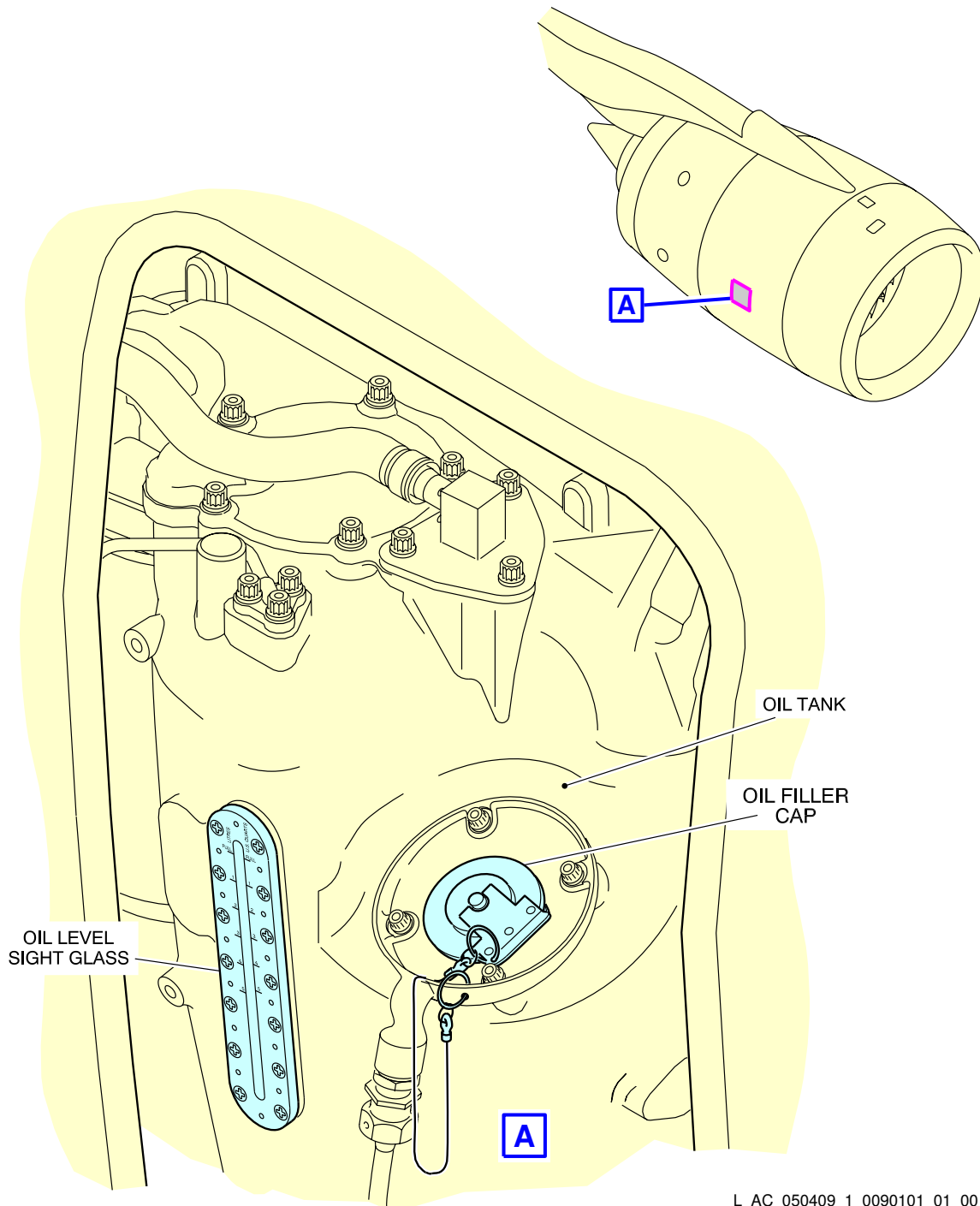

L_AC_050409_1_0090101_01_00

Ground Service Connections
Engine Oil Servicing - TRENT 900 Engines

**ON A/C A380-800 Models A380-800F Models

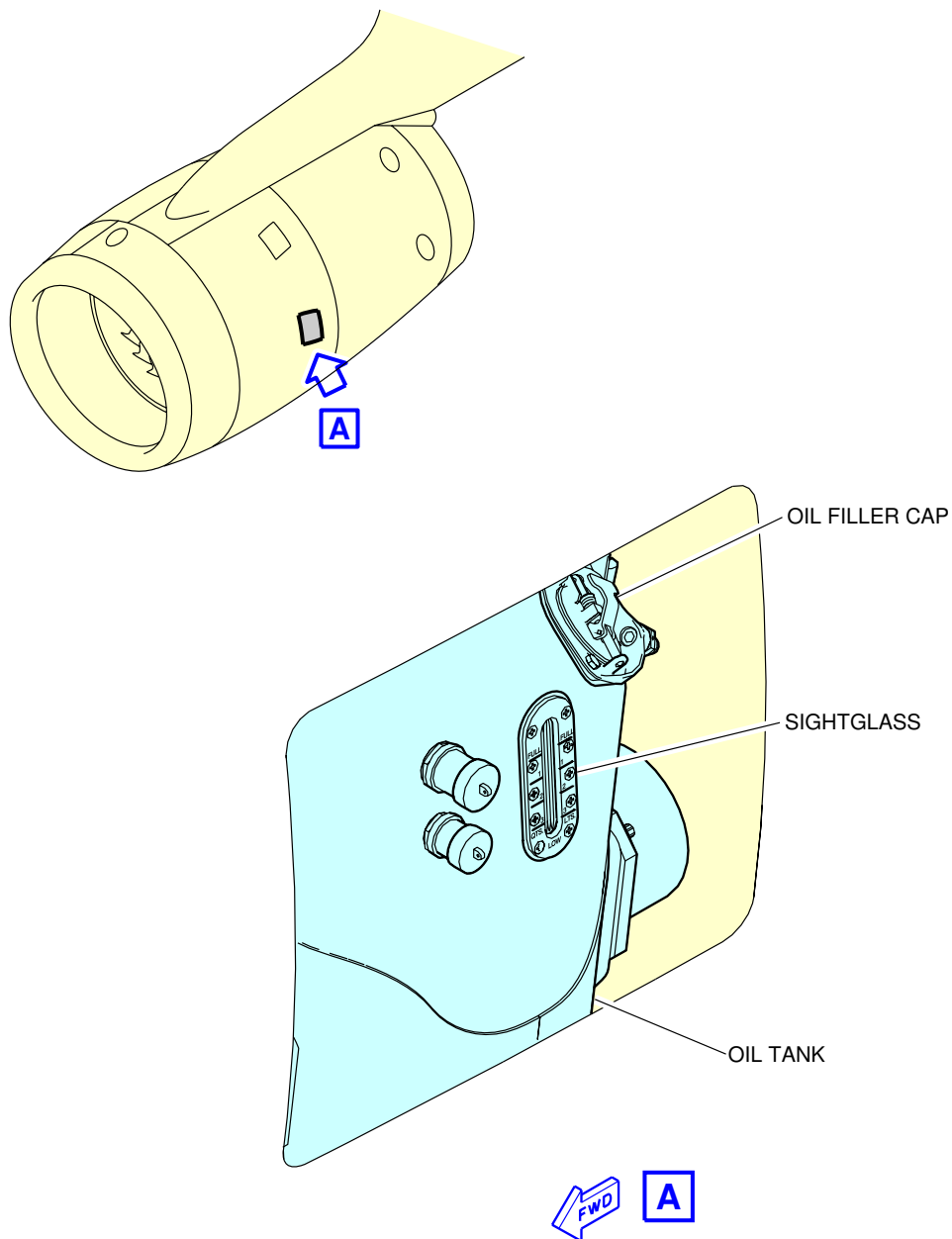

L_AC_050409_1_0100101_01_00

Ground Service Connections
Engine Oil Servicing - GP 7200 Engines

****ON A/C A380-800 Models A380-800F Models**

VFG Oil Servicing

1. VFG oil servicing (TRENT900 Engines)

	DISTANCE : Meters (ft)			
	AFT OF NOSE	FROM AIRPLANE CENTERLINE		MEAN HEIGHT FROM GROUND
		R SIDE	L SIDE	
- Engine 1 (access door 415CL)	33.17 (108.83)		26.14 (85.76)	2.56 (8.39)
- Engine 2 (access door 425CL)	25.57 (83.89)		15.31 (50.22)	1.33 (4.36)
- Engine 3 (access door 435CL)	25.57 (83.89)	13.93 (45.70)		1.33 (4.36)
- Engine 4 (access door 445CL)	33.17 (108.83)	24.90 (81.69)		2.56 (8.39)

2. VFG oil servicing (GP7200 Engines)

	DISTANCE : Meters (ft)			
	AFT OF NOSE	FROM AIRPLANE CENTERLINE		MEAN HEIGHT FROM GROUND
		R SIDE	L SIDE	
- Engine 1 (access door TBD)	34.49 (113.16)		25.43 (83.43)	2.63 (8.63)
- Engine 2 (access door TBD)	26.81 (87.96)		14.63 (48.00)	1.36 (4.46)
- Engine 3 (access door TBD)	26.81 (87.96)	14.63 (48.00)		1.36 (4.46)
- Engine 4 (access door TBD)	34.49 (113.16)	25.43 (83.43)		2.63 (8.63)

**ON A/C A380-800 Models A380-800F Models

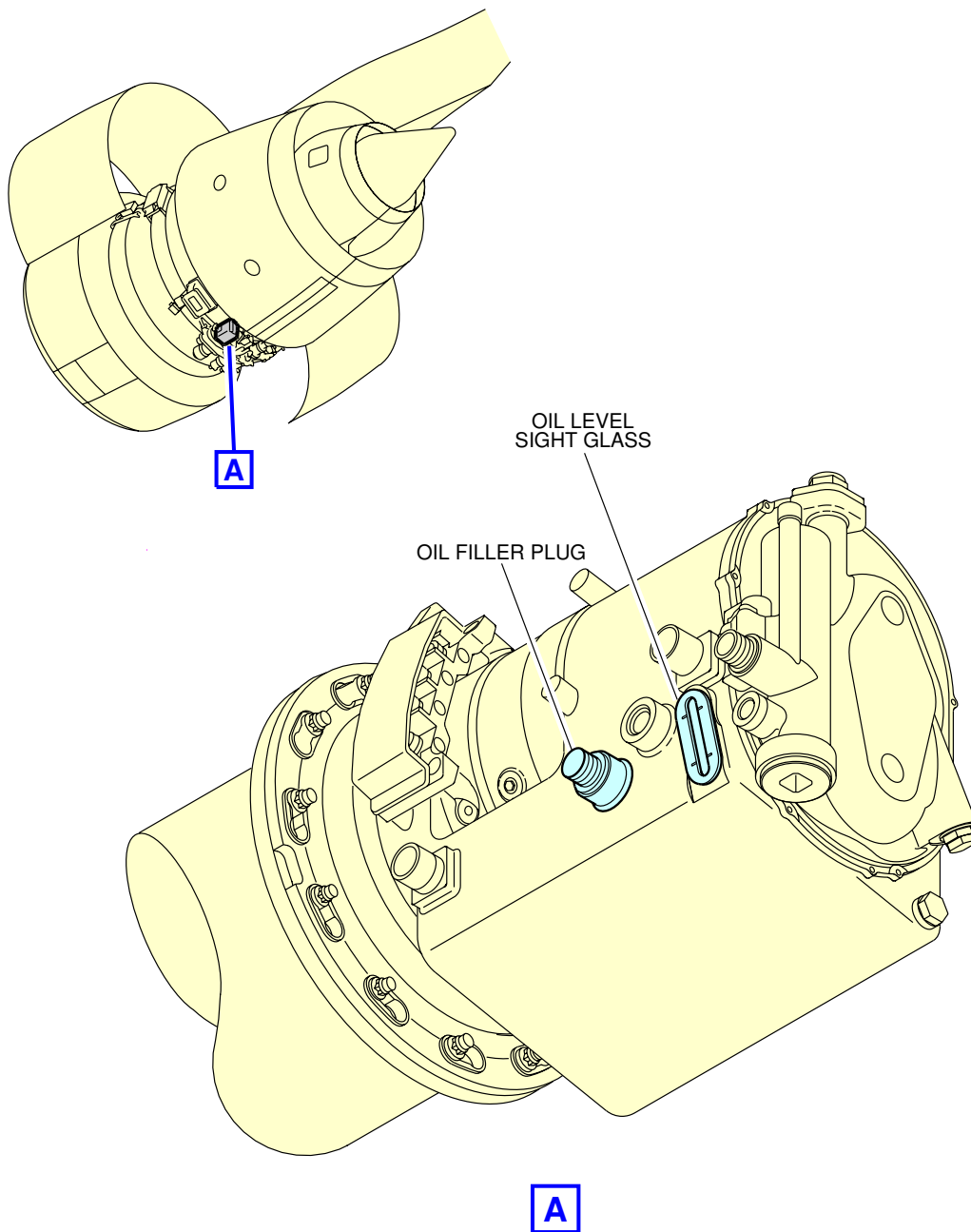

L_AC_050409_1_0110101_01_00

Ground Service Connections
VFG Oil Servicing - TRENT 900 Engines

**ON A/C A380-800 Models A380-800F Models

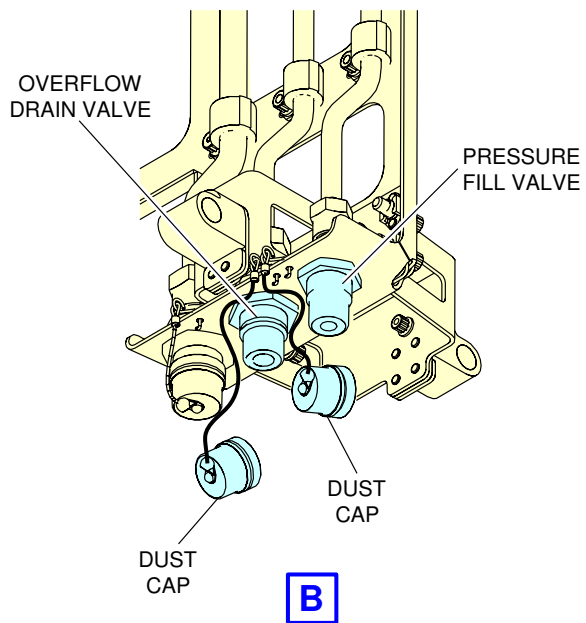
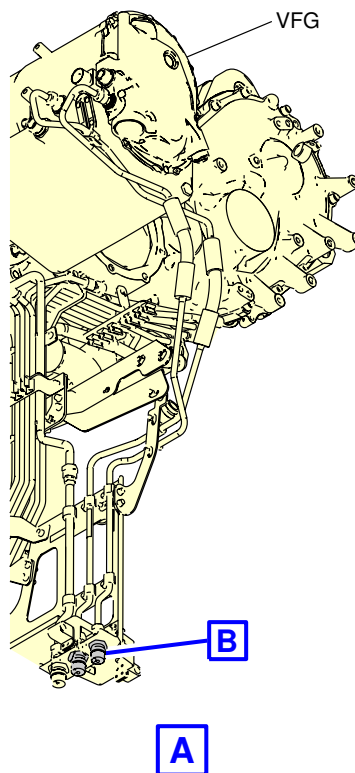
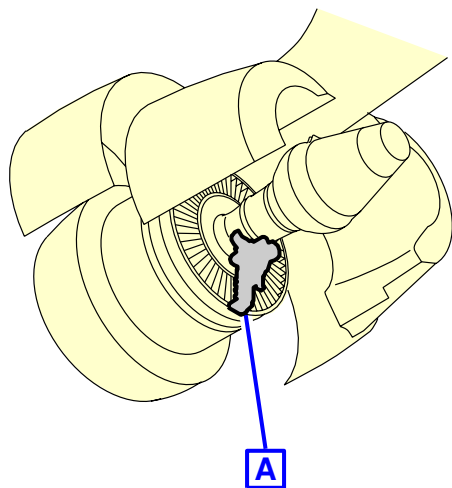

E-01416 (0805)
PW V

L_AC_050409_1_0120101_01_00

Ground Service Connections
VFG Oil Servicing - GP 7200 Engines

****ON A/C A380-800 Models A380-800F Models**

Starter Oil Servicing

1. Starter Oil Servicing (TRENT900 Engines)

	DISTANCE : Meters (ft)			
	AFT OF NOSE	FROM AIRPLANE CENTERLINE		MEAN HEIGHT FROM GROUND
		R SIDE	L SIDE	
- Engine 1	39.78 (130.51)		25.78 (84.57)	2.59 (8.49)
- Engine 2	32.15 (105.49)		14.94 (49.01)	1.39 (4.56)
- Engine 3	32.15 (105.49)	14.42 (47.30)		1.39 (4.56)
- Engine 4	39.78 (130.51)	25.25 (82.84)		2.59 (8.49)

2. Starter Oil Servicing (GP7200 Engines)

	DISTANCE : Meters (ft)			
	AFT OF NOSE	FROM AIRPLANE CENTERLINE		MEAN HEIGHT FROM GROUND
		R SIDE	L SIDE	
- Engine 1 (access door TBD)	40.42 (132.61)		27.34 (89.70)	3.35 (10.99)
- Engine 2 (access door TBD)	32.74 (107.41)		16.55 (54.30)	2.47 (8.10)
- Engine 3 (access door TBD)	32.74 (107.41)	12.71 (41.70)		2.47 (8.10)
- Engine 4 (access door TBD)	40.42 (132.61)	23.53 (77.20)		3.35 (10.99)

**ON A/C A380-800 Models A380-800F Models

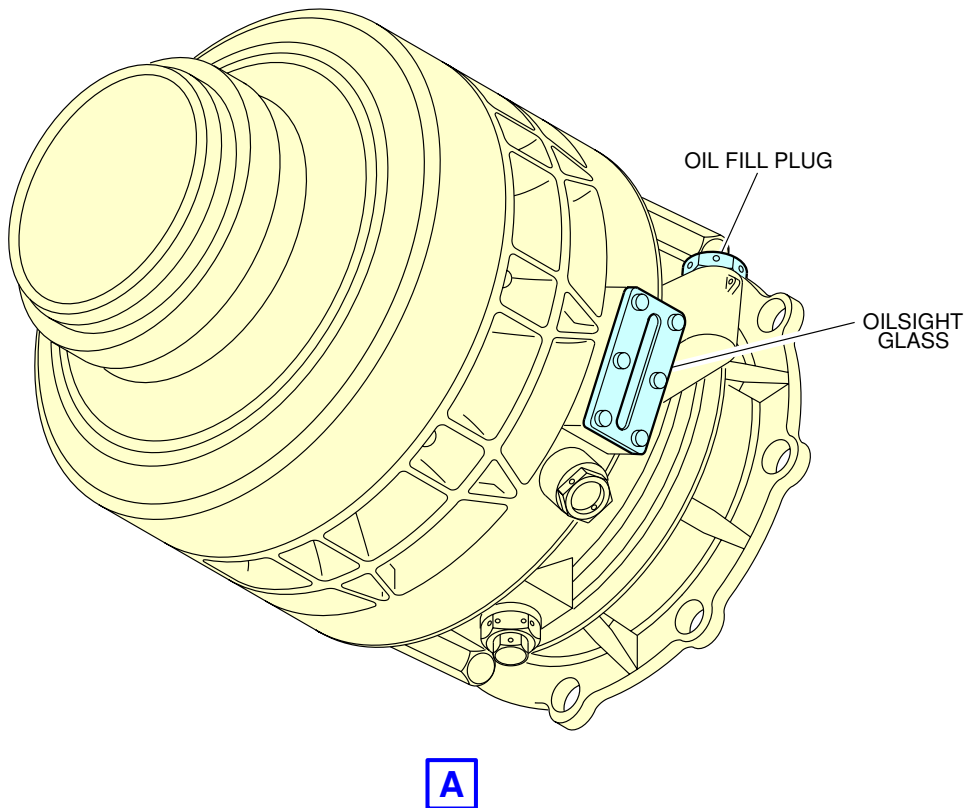
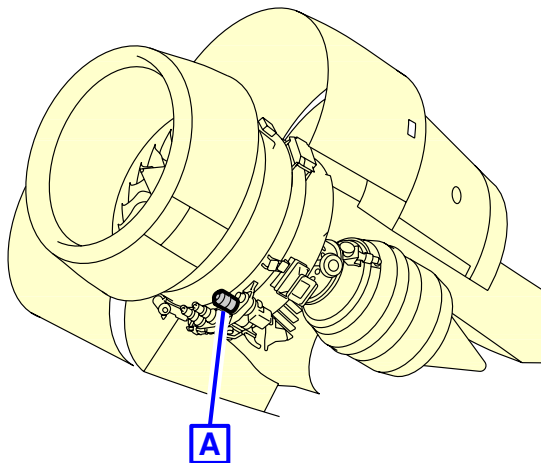

L_AC_050409_1_0130101_01_00

Ground Service Connections
Starter Oil Servicing - TRENT 900 Engines

**ON A/C A380-800 Models A380-800F Models

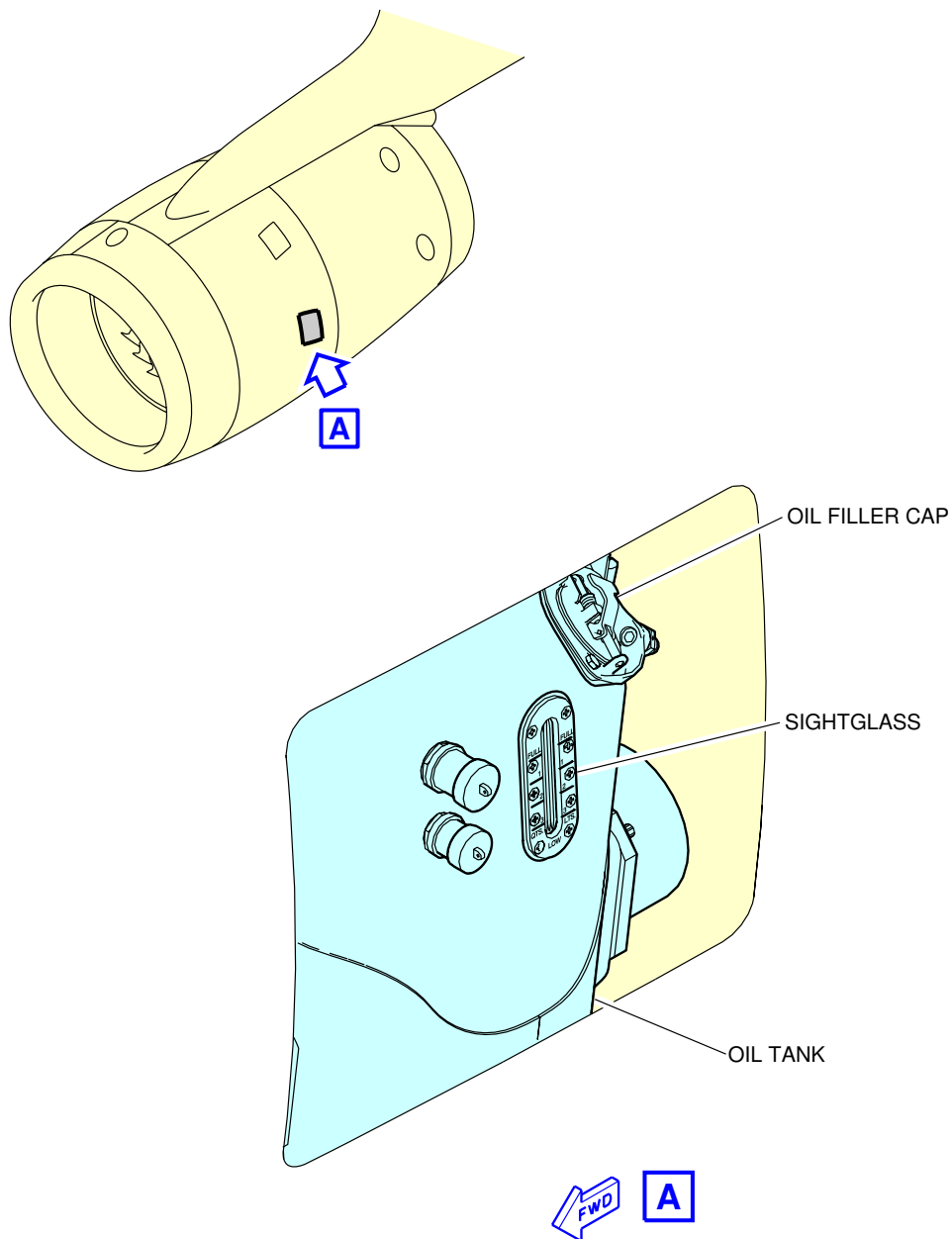

L_AC_050409_1_0140101_01_00

Ground Service Connections
Starter Oil Servicing - GP 7200 Engines

****ON A/C A380-800 Models A380-800F Models**

APU Oil Servicing

1. APU Oil

	DISTANCE : Meters (ft)			
	AFT OF NOSE	FROM AIRPLANE CENTERLINE		MEAN HEIGHT FROM GROUND
		R SIDE	L SIDE	
- access doors : 315AL, 315AR	67.55 (221.62)		0.44 (1.44)	6.83 (22.40)

A. Capacity :

(1) 18.13L (4.35 USgal)

**ON A/C A380-800 Models A380-800F Models

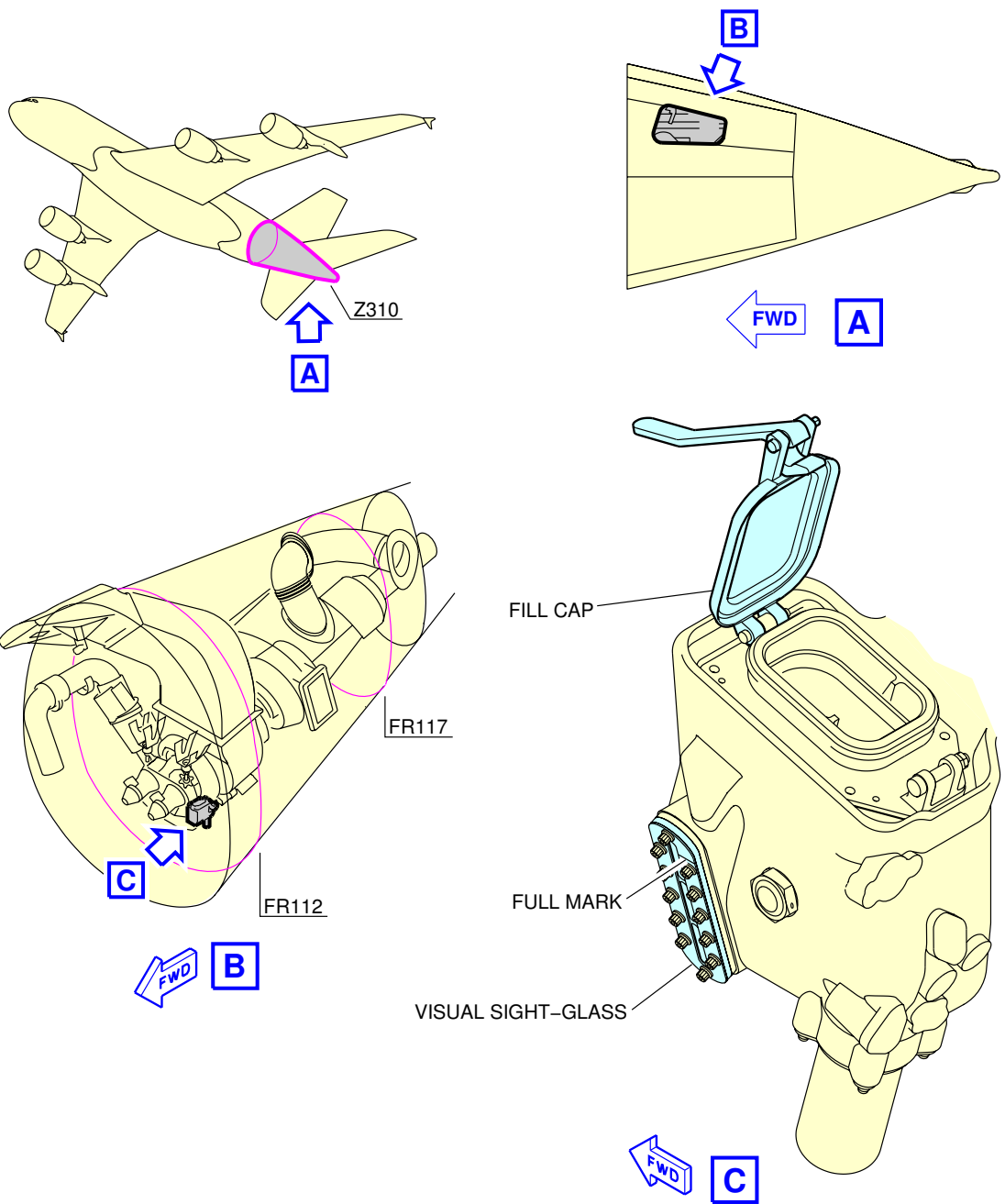

L_AC_050409_1_0150101_01_00

Ground Service Connections
APU Oil Servicing

5-4-10 Vacuum Toilet System

****ON A/C A380-800 Models**

Vacuum Toilet System - Pax

1. Waste Water System

	DISTANCE : Meters (ft)			
	AFT OF NOSE	FROM AIRPLANE CENTERLINE		MEAN HEIGHT FROM GROUND
		R SIDE	L SIDE	
- access door 171AL	53.31 (174.90)		0.26 (0.85)	3.40 (11.15)

A. Connectors :

- (1) flushing and filling : 1 in.
- (2) draining : 4 in.

B. Capacity : 2100 l

C. Operating pressure for the waste tank rinsing process: 50 psi (max 125 psi)

D. Flow rate : 40 l/min

**ON A/C A380-800 Models

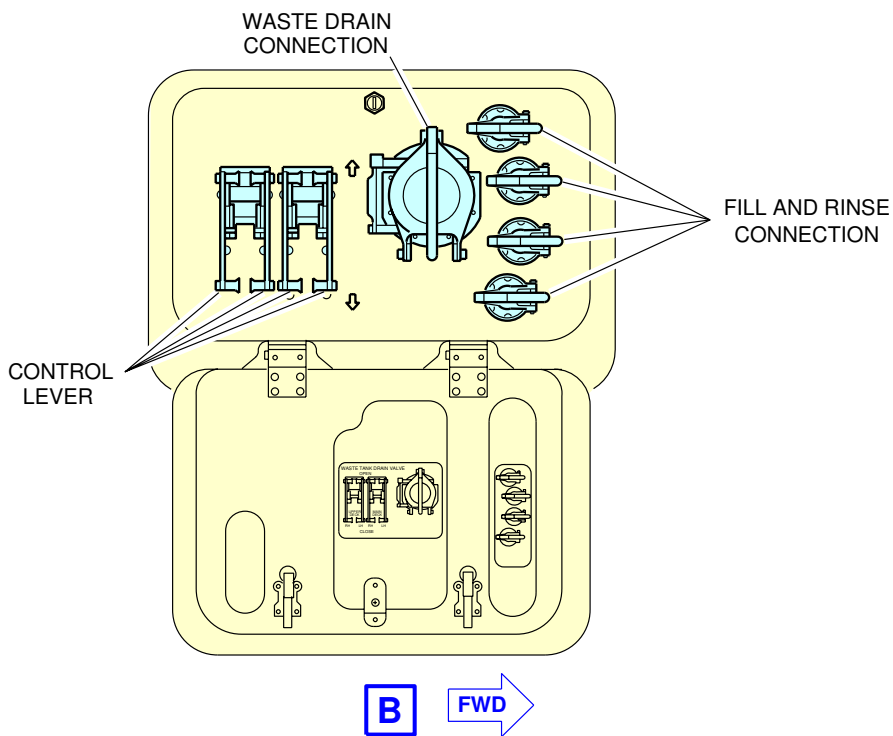
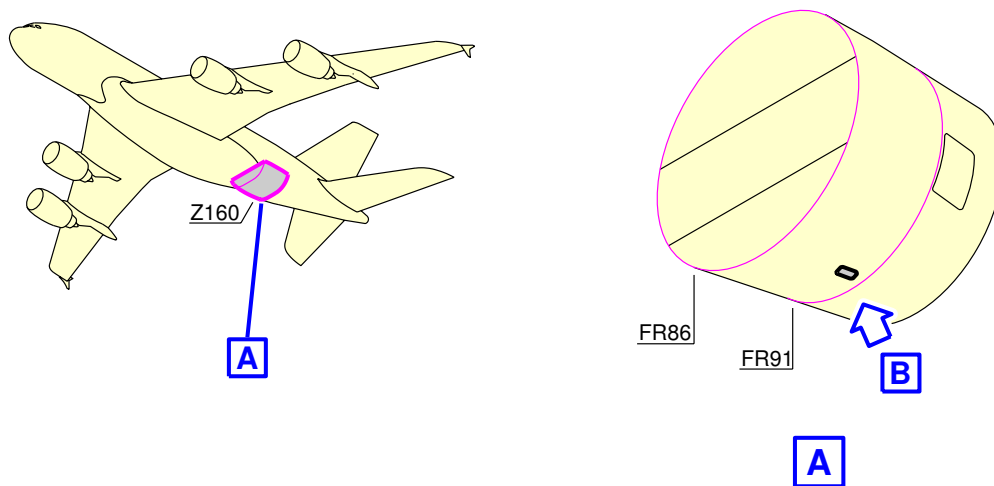

L_AC_050410_1_0010101_01_00

Ground Service Connections
Vacuum Toilet System - A380-800 Models

****ON A/C A380-800F Models**Vacuum Toilet System - Freighter

1. Waste Water System

	DISTANCE : Meters (ft)			
	AFT OF NOSE	FROM AIRPLANE CENTERLINE		MEAN HEIGHT FROM GROUND
		R SIDE	L SIDE	
- access door TBD	11.11 (36.45)		2.48 (8.14 ft)	3.51 (11.52)

A. Connectors :

(1) flushing and filling : 1 in.

(2) draining : 4 in.

B. Capacity : 80 l

C. Operating pressure for the waste tank rinsing process: 50 psi (max 125 psi)

D. Flow rate : 40 l/min

**ON A/C A380-800F Models

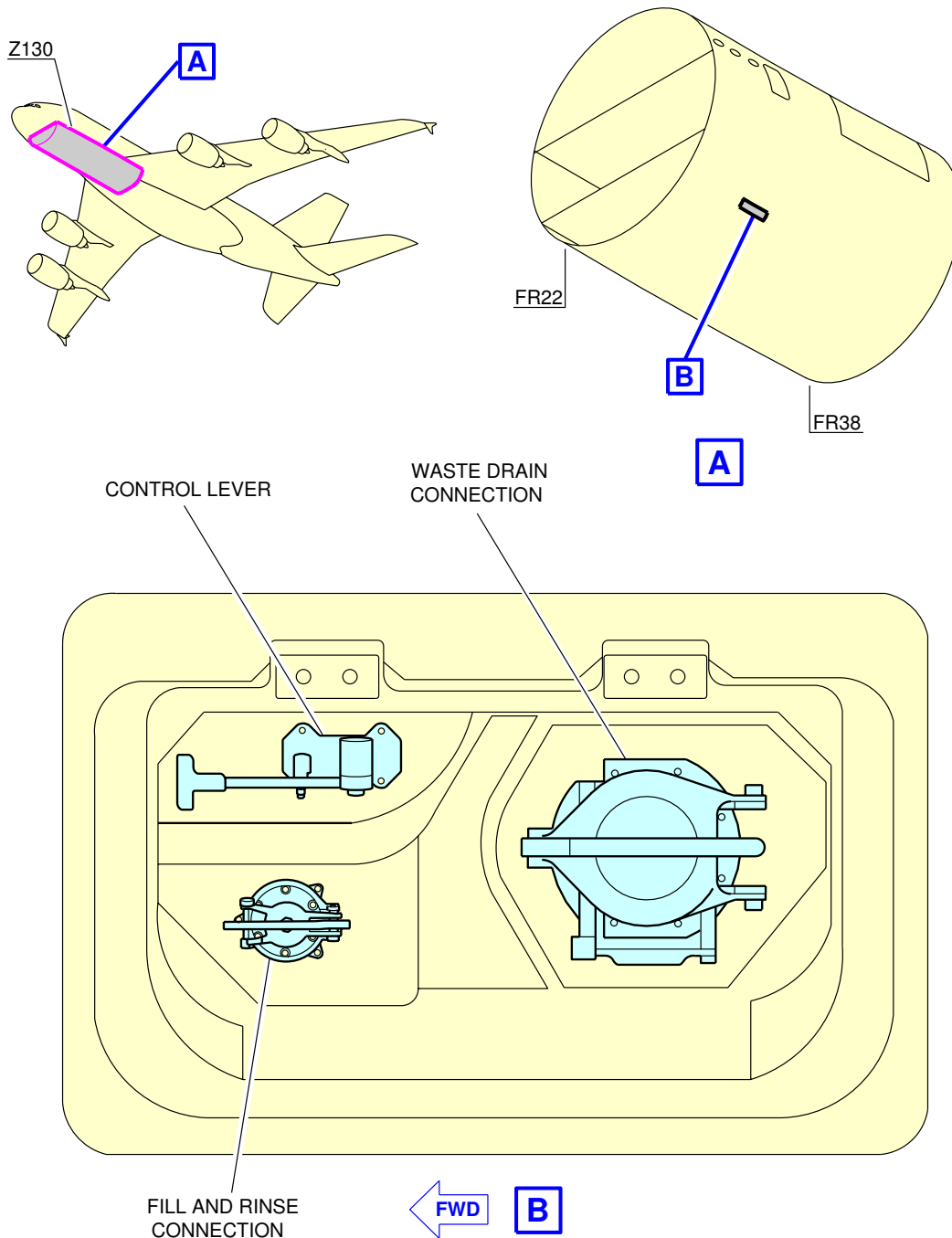

L_AC_050410_1_0020101_01_00

Ground Service Connections
Vacuum Toilet System - A380-800F Models



AIRPLANE CHARACTERISTICS

5-5-0 Engine Starting Pneumatic Requirements

****ON A/C A380-800 Models A380-800F Models**

Engine Starting Pneumatic Requirements

1. Engine Starting Pneumatic Requirements



AIRPLANE CHARACTERISTICS

5-5-1 Outside Air Temperature = -40 °C (-40 °F)

****ON A/C A380-800 Models A380-800F Models**

Outside Air Temperature = -40 °C (-40 °F)

1. This section provides the engine starting pneumatic requirements for an ambient temperature of -40 °C (-40 °F).

**ON A/C A380-800 Models A380-800F Models

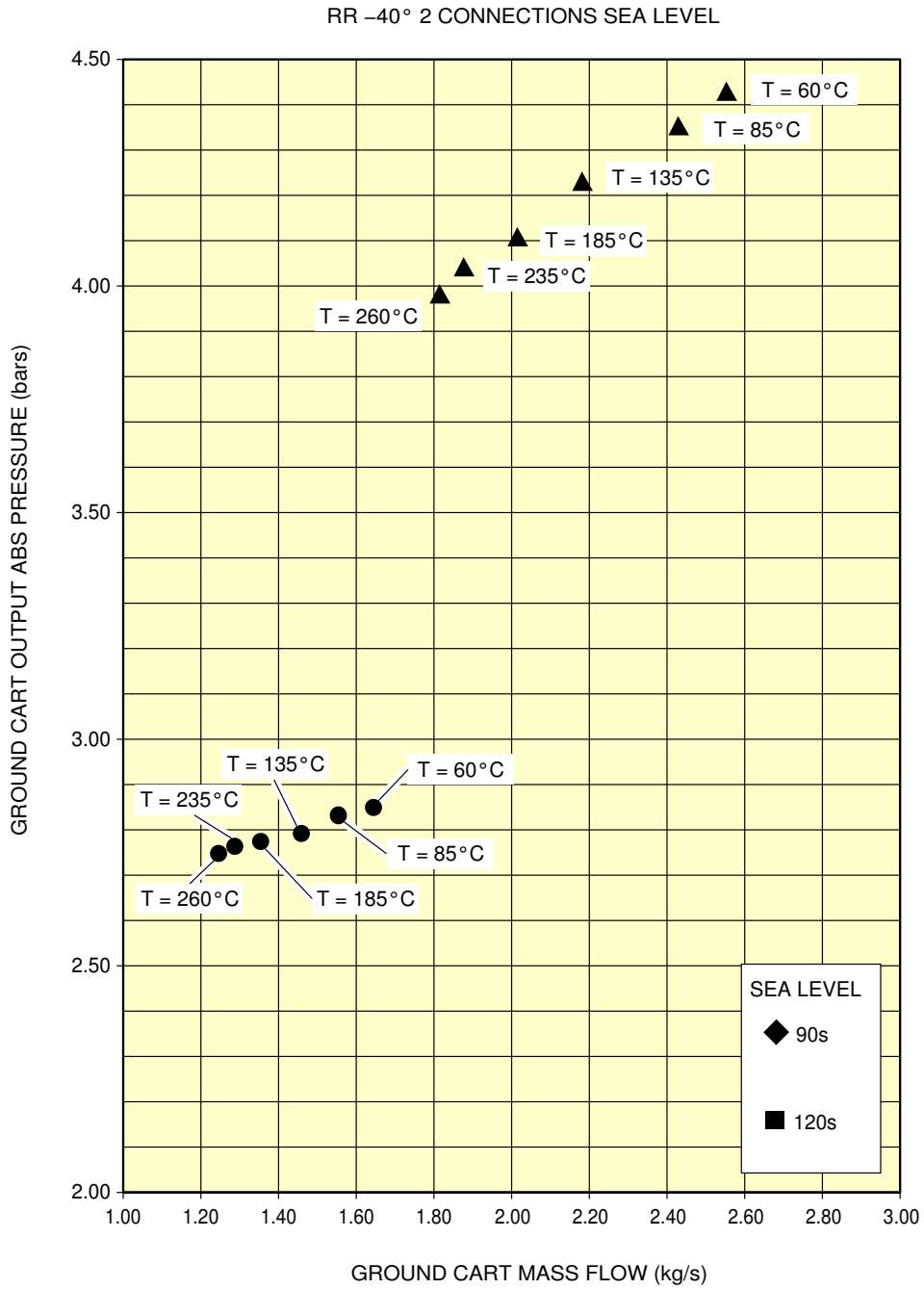

L_AC_050501_1_0010101_01_00

Engine Starting Pneumatic Requirements (two high pressure ground carts)
 Ambient Temperature -40 °C (-40 °F), sea level - TRENT 900 Engines

**ON A/C A380-800 Models A380-800F Models

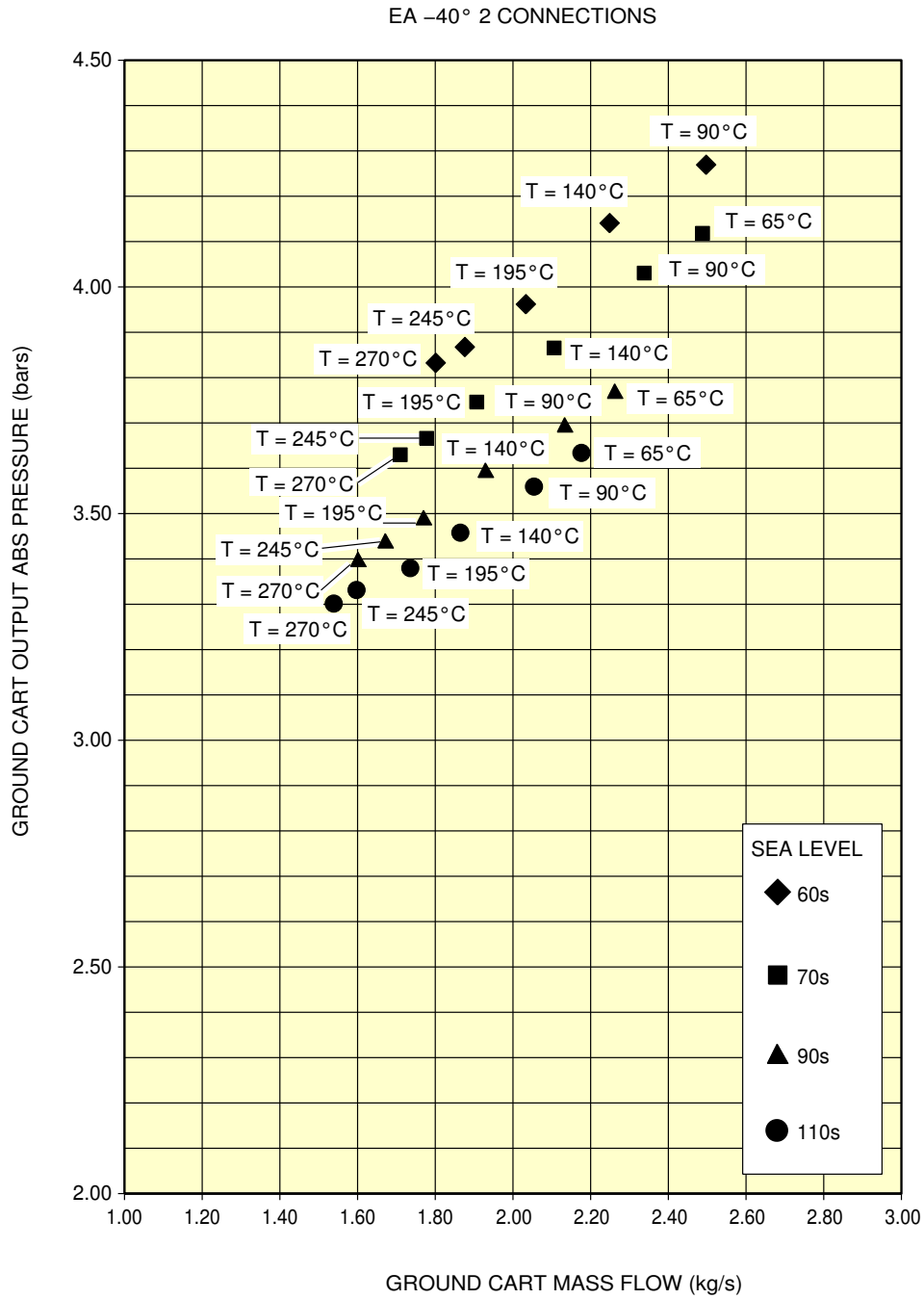

L_AC_050501_1_0020101_01_00

Engine Starting Pneumatic Requirements (two high pressure ground carts)
Ambient Temperature -40 °C (-40 °F), sea level - GP 7200 Engines

**ON A/C A380-800 Models A380-800F Models

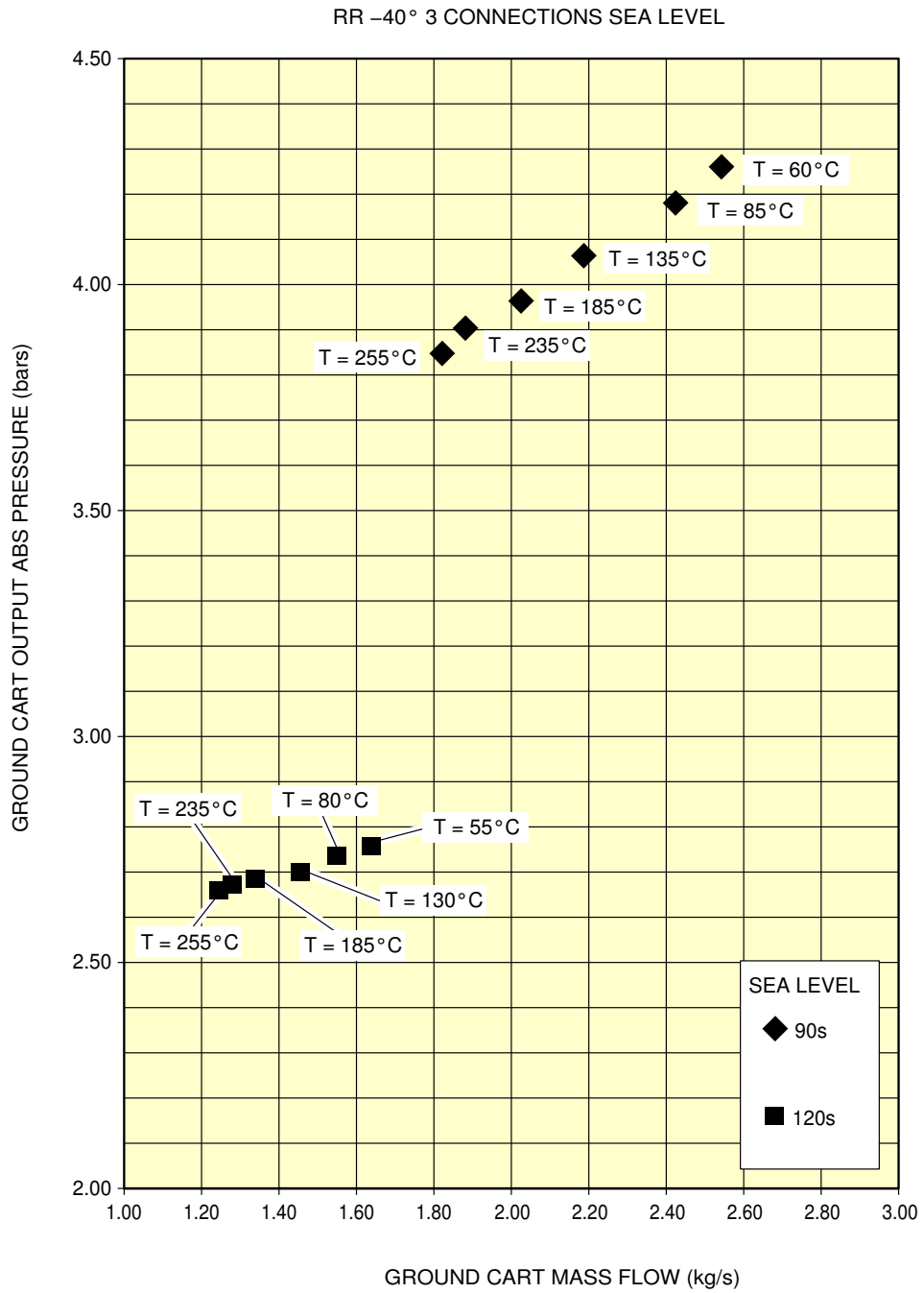

L_AC_050501_1_0030101_01_00

Engine Starting Pneumatic Requirements (three high pressure ground carts)
 Ambient Temperature -40 °C (-40 °F), Sea Level - TRENT 900 Engines

**ON A/C A380-800 Models A380-800F Models

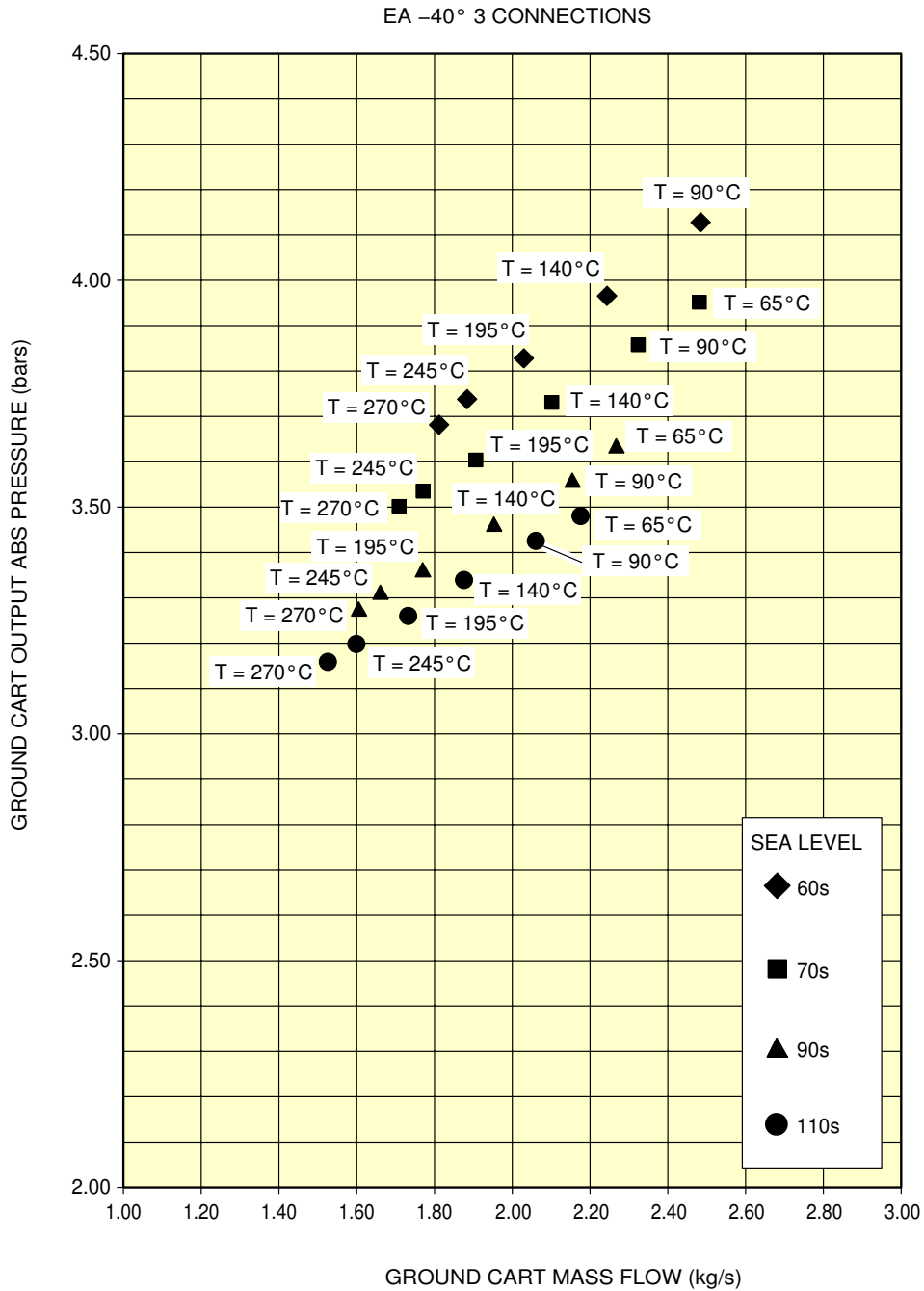

L_AC_050501_1_0040101_01_00

Engine Starting Pneumatic Requirements (three high pressure ground carts)
Ambient Temperature -40°C (-40°F), Sea Level - GP 7200 Engines



AIRPLANE CHARACTERISTICS

5-5-2 Outside Air Temperature = 15 °C (59 °F)

****ON A/C A380-800 Models A380-800F Models**

Outside Air Temperature = 15 °C (59 °F)

1. This section provides the engine starting pneumatic requirements for an ambient temperature of +15 °C (+59.0 °F)

**ON A/C A380-800 Models A380-800F Models

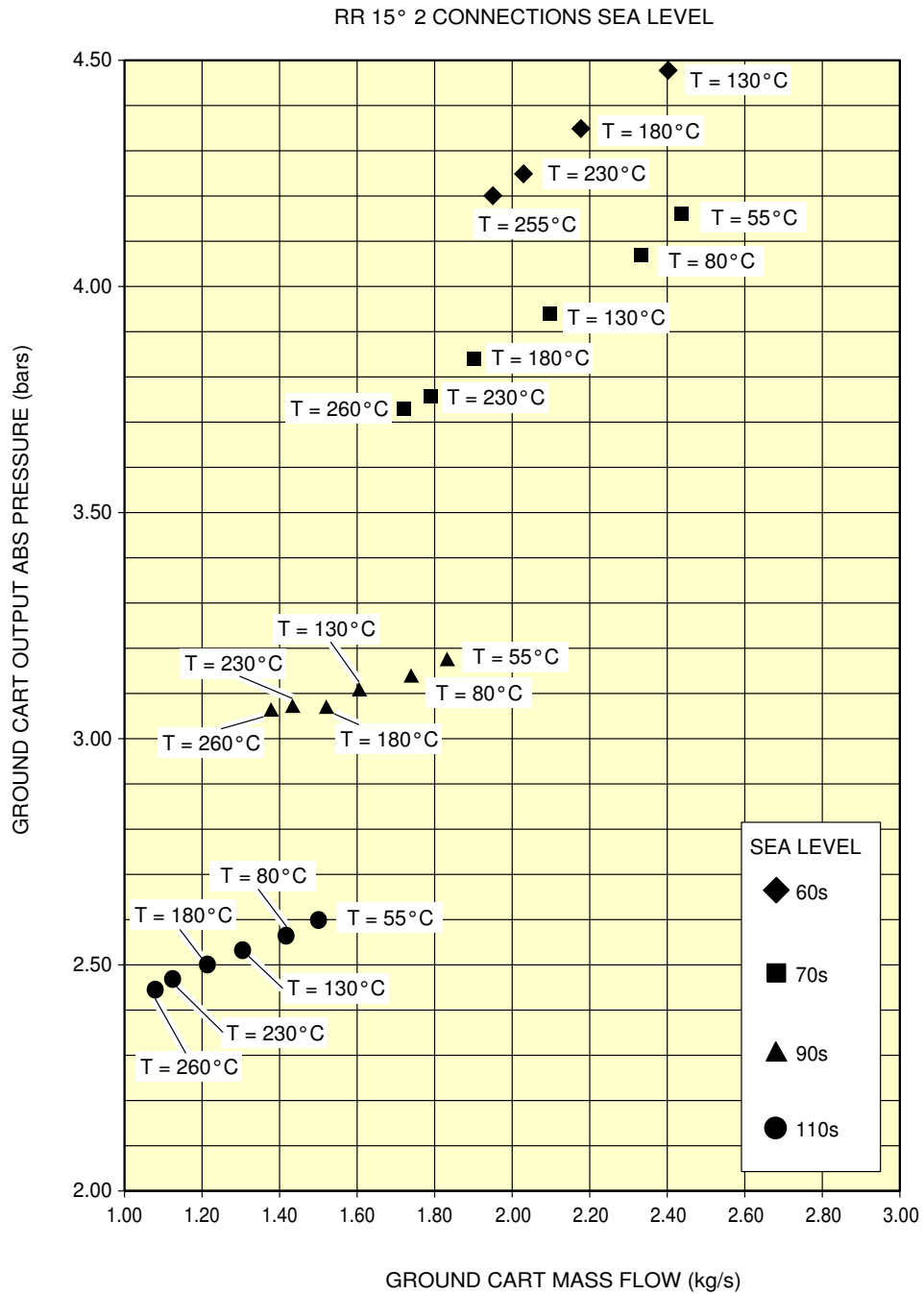

L_AC_050502_1_0010101_01_00

Engine Starting Pneumatic Requirements (two high pressure ground carts)
Ambient Temperature +15 °C (+59 °F), Sea Level - TRENT 900 Engines

**ON A/C A380-800 Models A380-800F Models

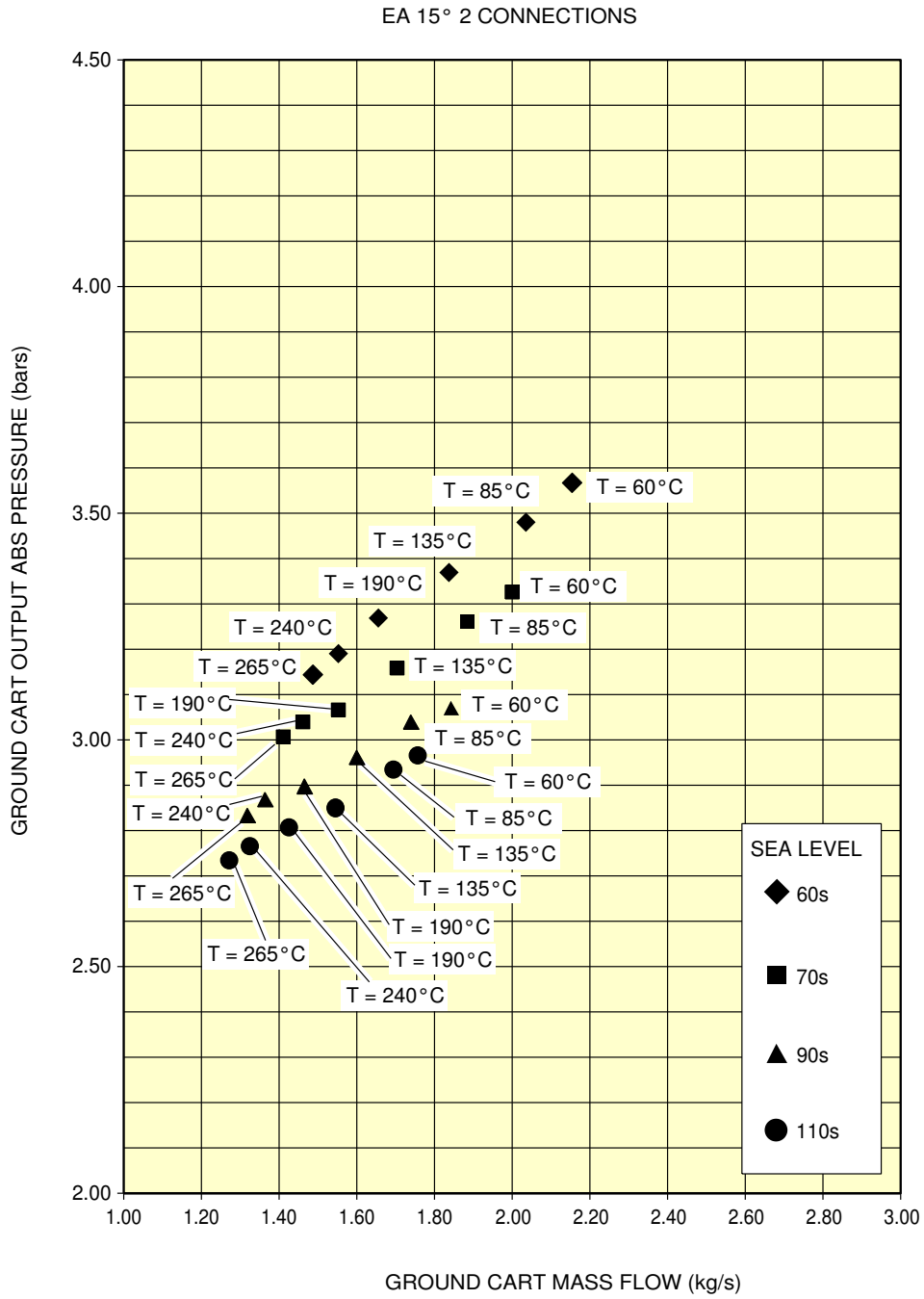

L_AC_050502_1_0020101_01_00

Engine Starting Pneumatic Requirements (two high pressure ground carts)
Ambient Temperature +15° C (+59° F), Sea Level - GP 7200 Engines

**ON A/C A380-800 Models A380-800F Models

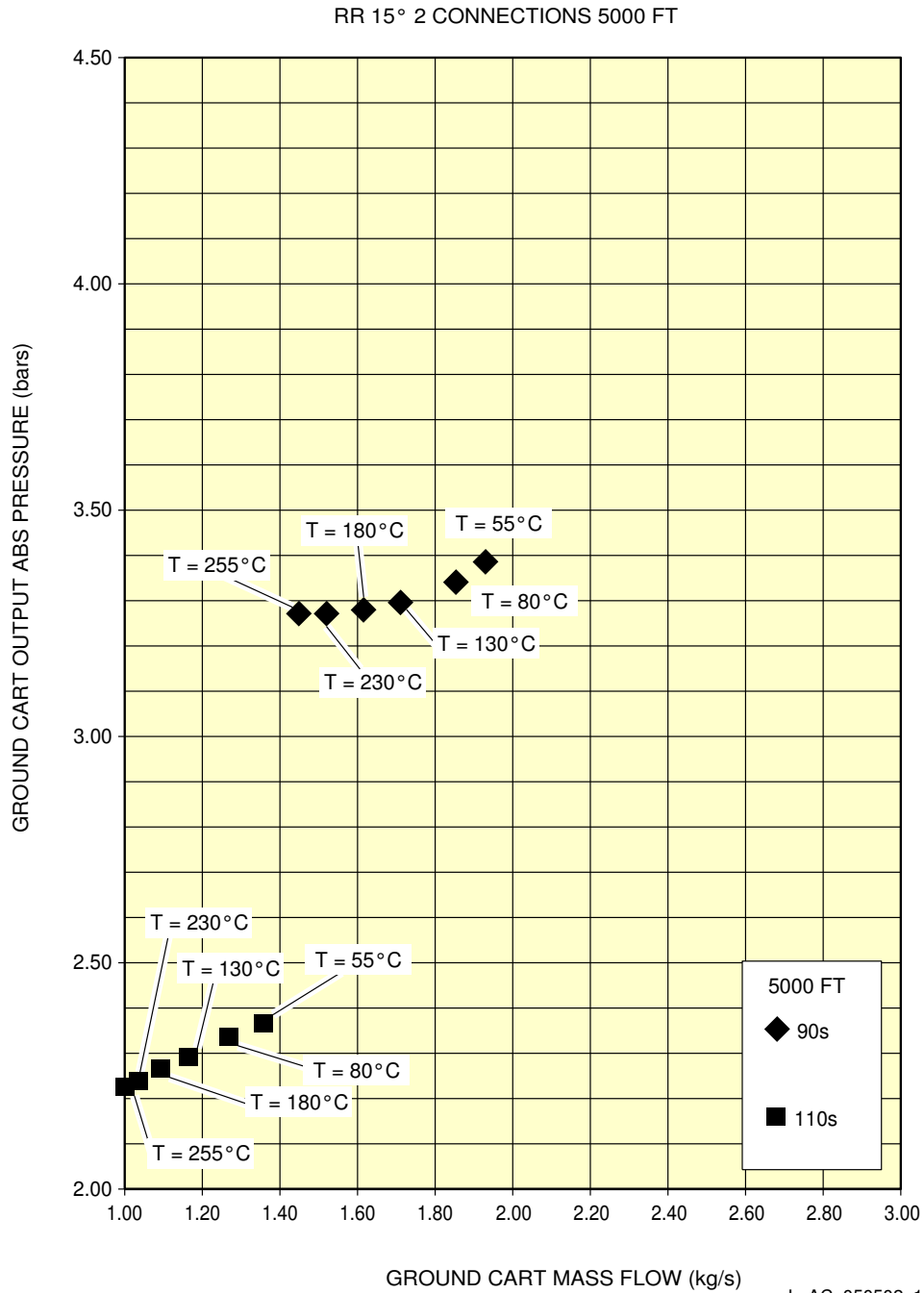

Engine Starting Pneumatic Requirements (two high pressure ground carts)
 Ambient Temperature +15° C (+59° F), 5000FT Level - TRENT 900 Engines

****ON A/C A380-800 Models A380-800F Models**

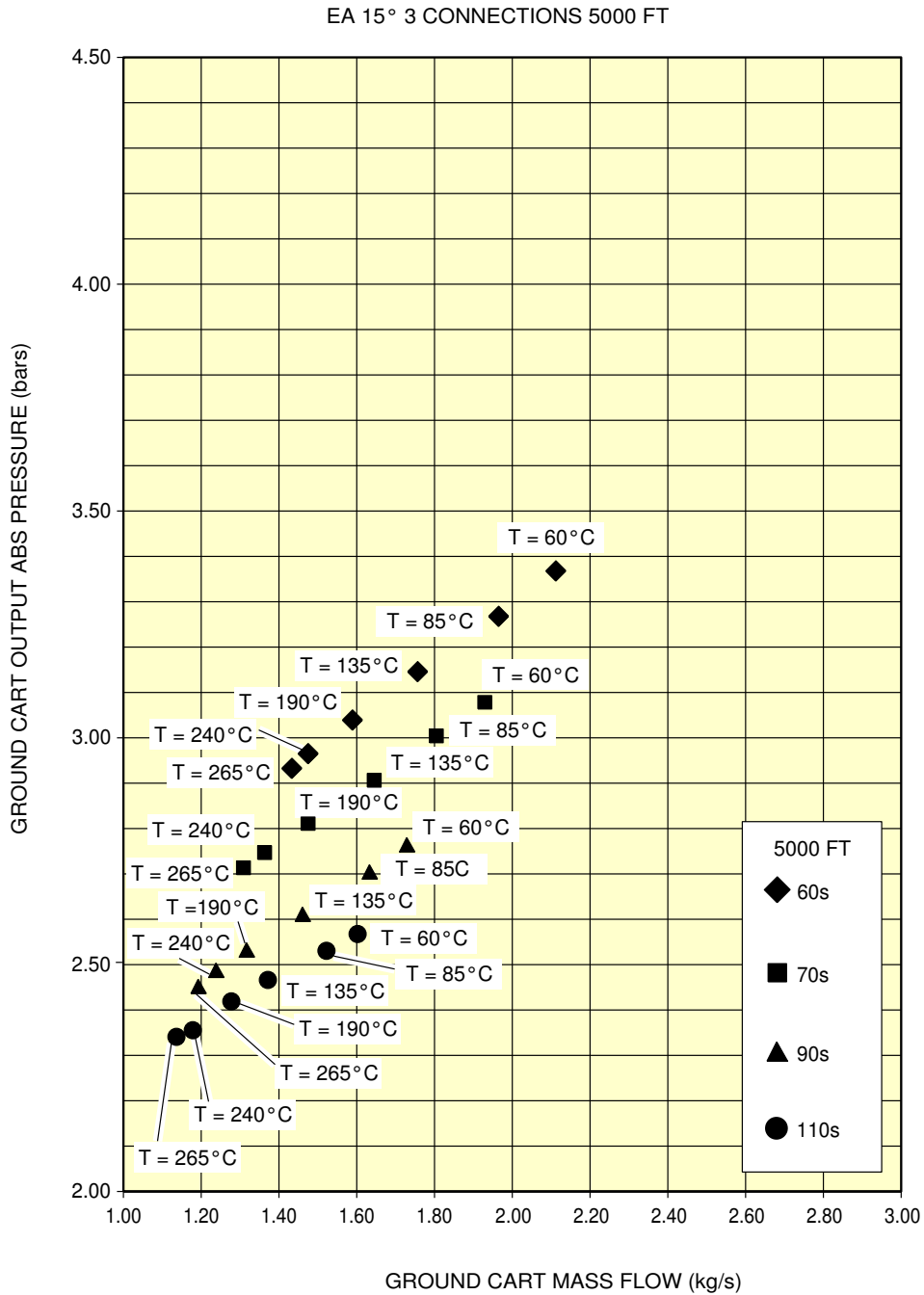

L_AC_050502_1_0040101_01_00

Engine Starting Pneumatic Requirements (two high pressure ground carts)
 Ambient Temperature +15 °C (+59 °F), 5000FT Level - GP 7200 Engines

****ON A/C A380-800 Models A380-800F Models**

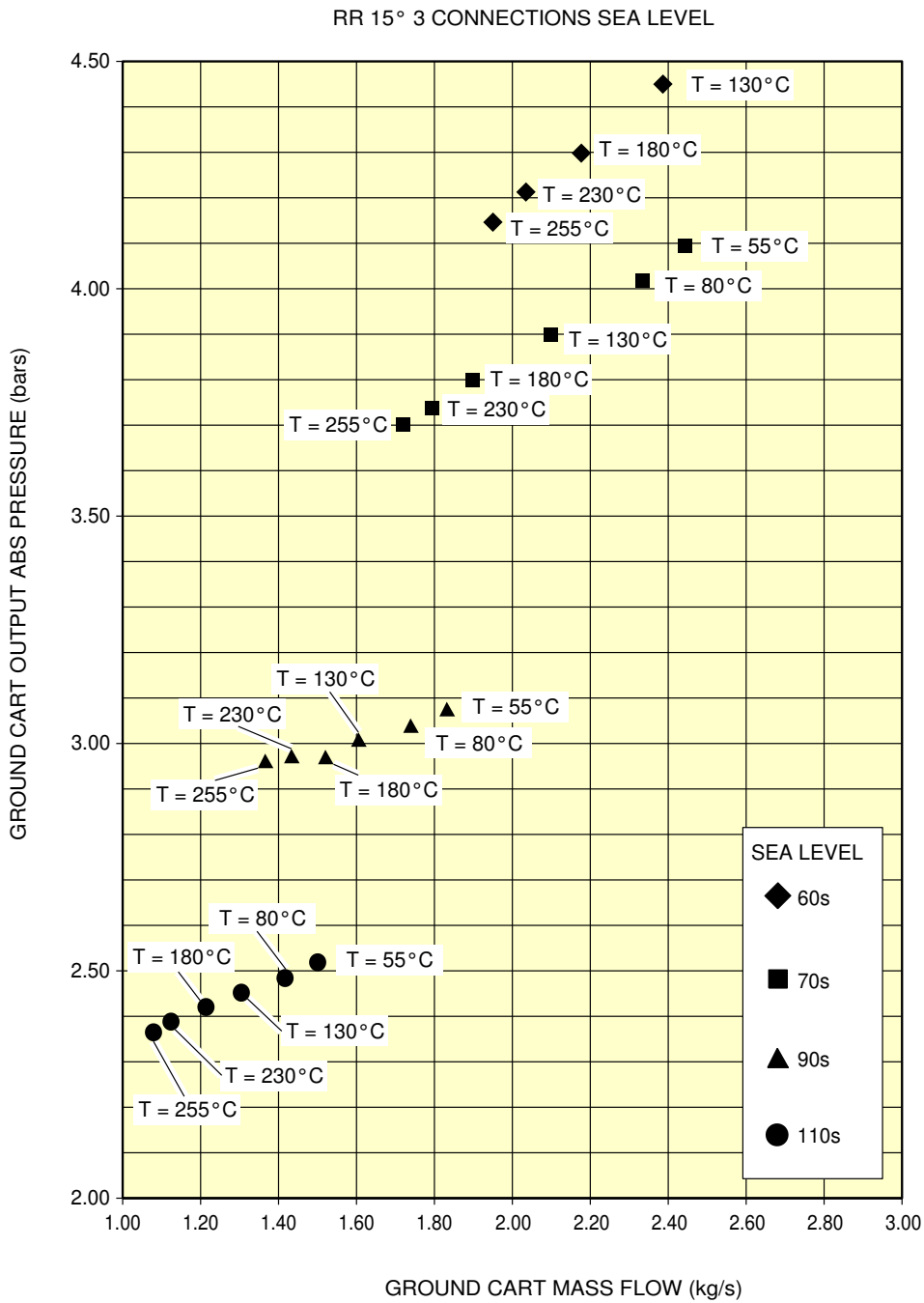

L_AC_050502_1_0050101_01_00

Engine Starting Pneumatic Requirements (three high pressure ground carts)
Ambient Temperature +15 °C (+59 °F), Sea Level - TRENT 900 Engines

**ON A/C A380-800 Models A380-800F Models

EA 15° 3 CONNECTIONS

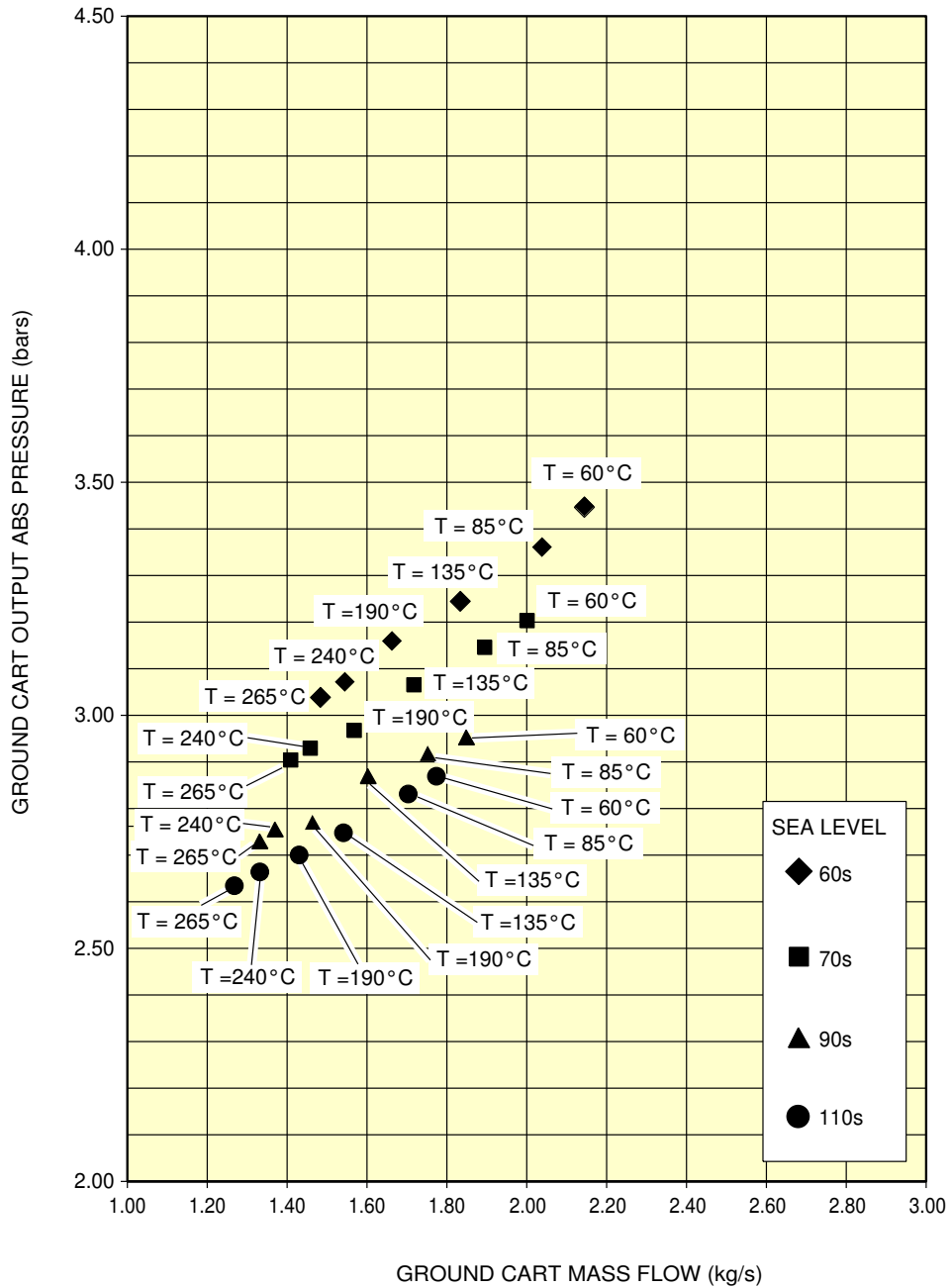

L_AC_050502_1_0060101_01_00

Engine Starting Pneumatic Requirements (three high pressure ground carts)
Ambient Temperature +15° C (+59° F), Sea Level - GP 7200 Engines

**ON A/C A380-800 Models A380-800F Models

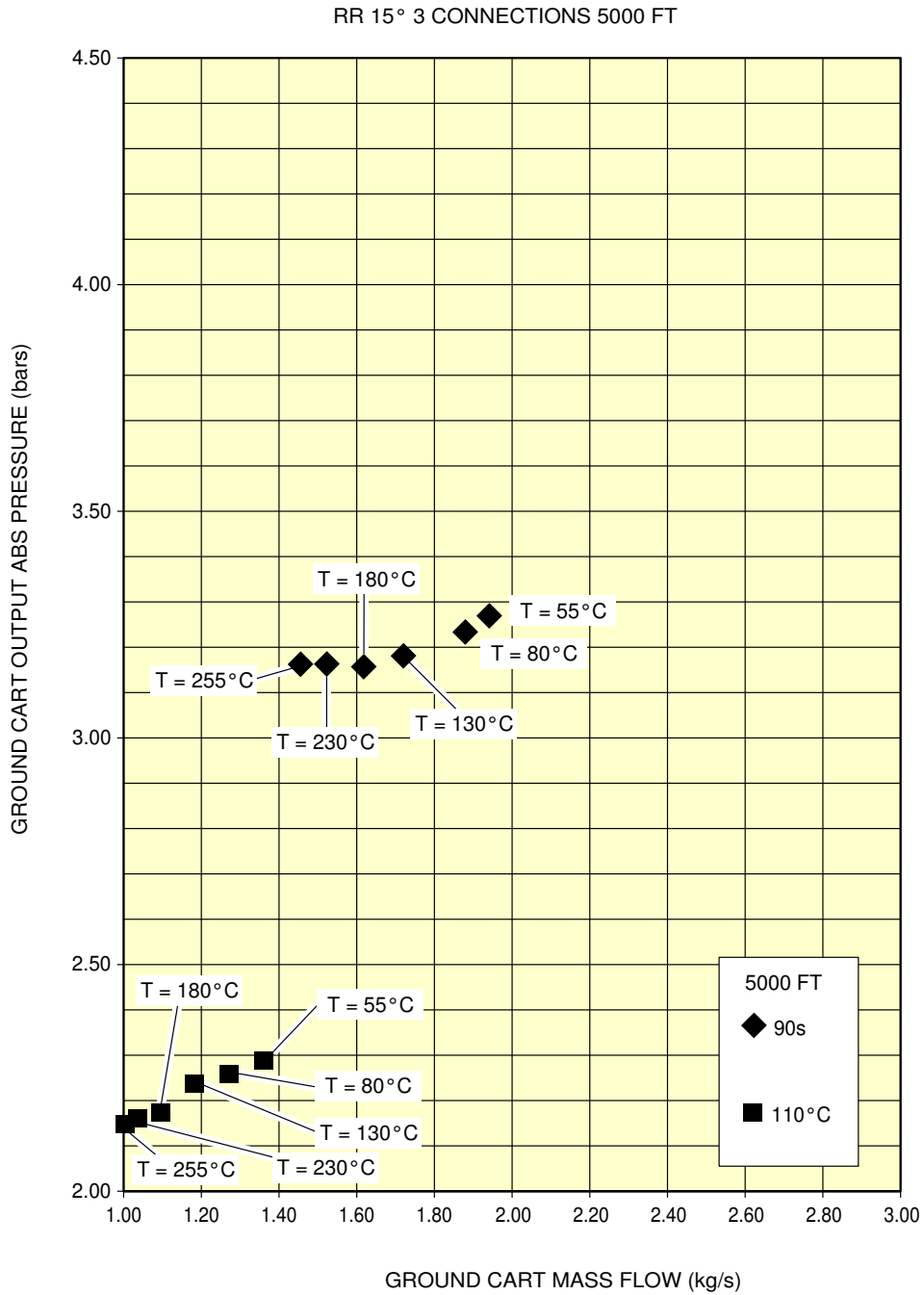

L_AC_050502_1_0070101_01_00

Engine Starting Pneumatic Requirements (three high pressure ground carts)
 Ambient Temperature +15° C (+59° F), 5000FT Level - TRENT 900 Engines

**ON A/C A380-800 Models A380-800F Models

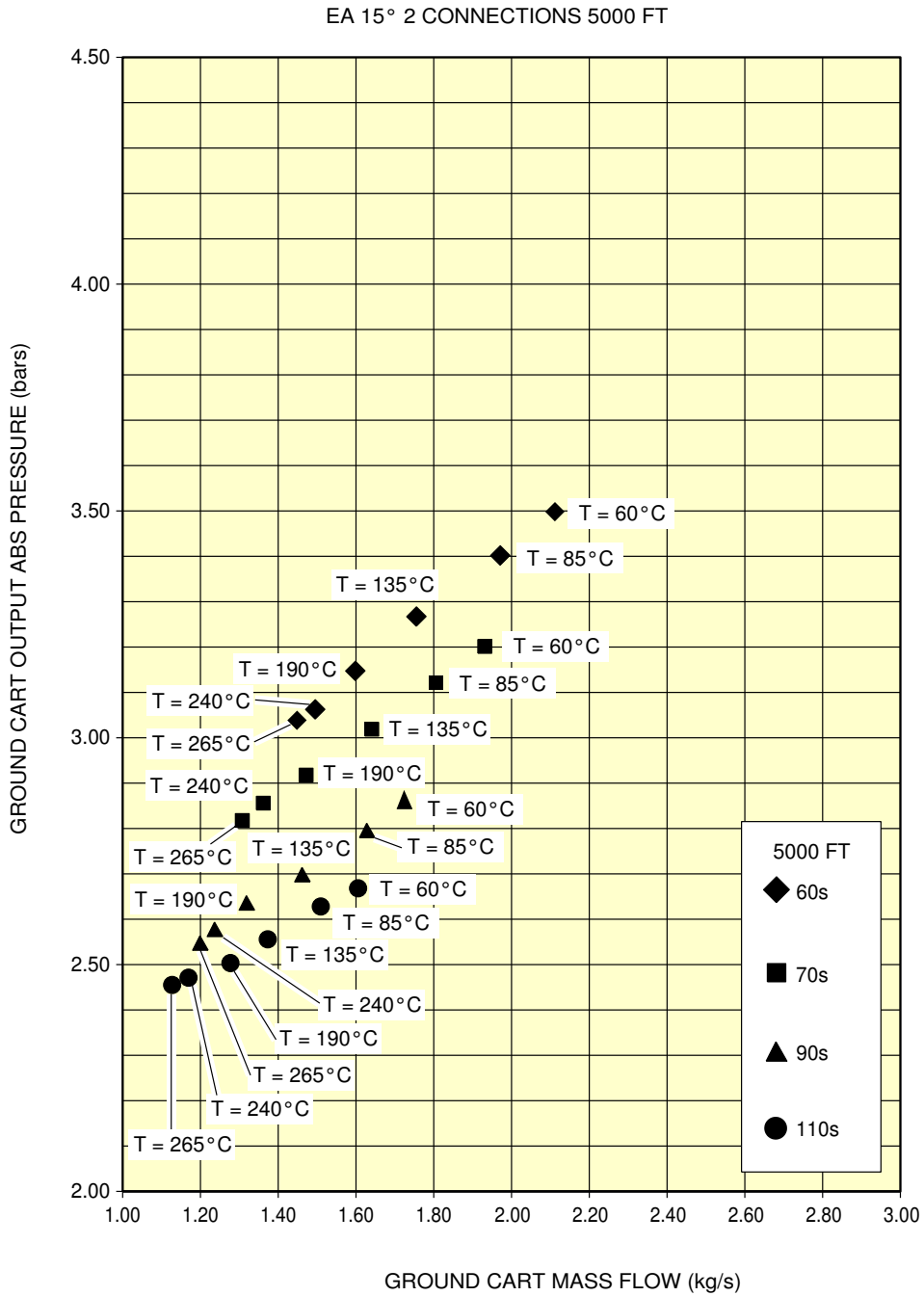

Engine Starting Pneumatic Requirements (three high pressure ground carts)
 Ambient Temperature +15 °C (+59 °F), 5000FT Level - GP 7200 Engines



AIRPLANE CHARACTERISTICS

5-5-3 Outside Air Temperature = 50 °C (122 °F)

****ON A/C A380-800 Models A380-800F Models**

Outside Air Temperature = 50 °C (122 °F)

1. This section provides the engine starting pneumatic requirements for an ambient temperature of +55 °C (+131.0 °F).

**ON A/C A380-800 Models A380-800F Models

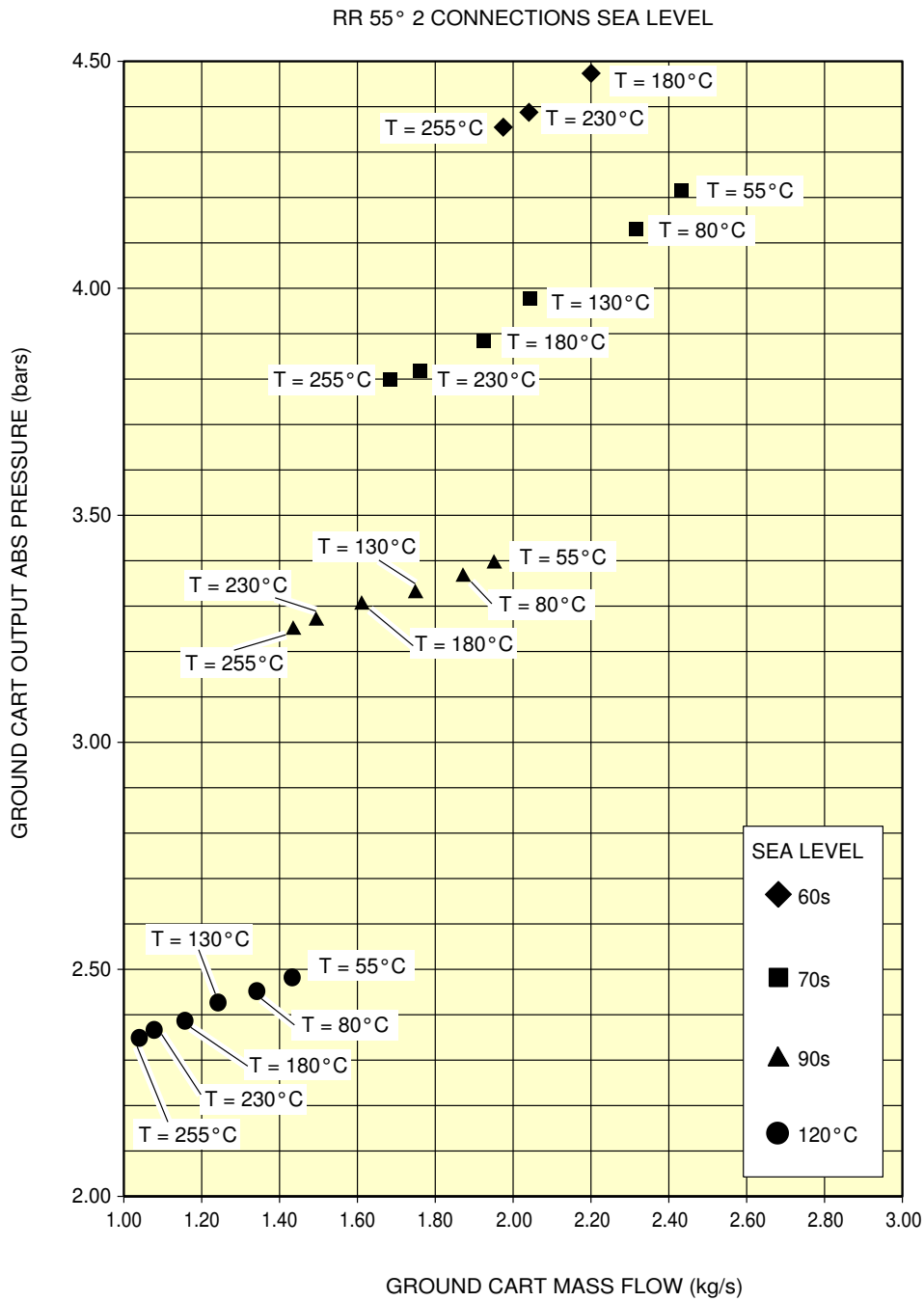

L_AC_050503_1_0010101_01_00

Engine Starting Pneumatic Requirements (two high pressure ground carts)
Ambient Temperature +55 °C (+131 °F), Sea Level - TRENT 900 Engines

**ON A/C A380-800 Models A380-800F Models

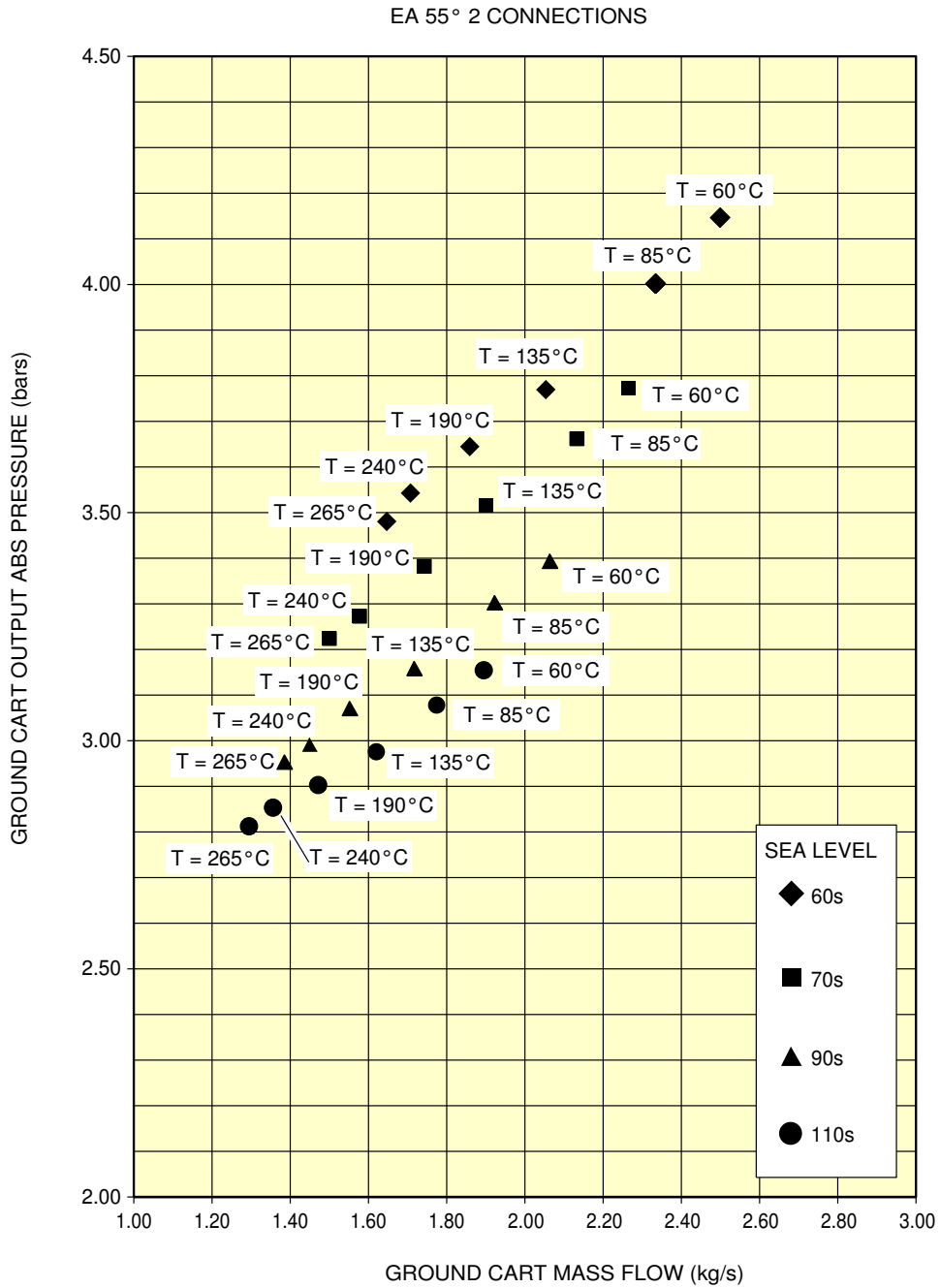

L_AC_050503_1_0020101_01_00

Engine Starting Pneumatic Requirements (two high pressure ground carts)
 Ambient Temperature +55 °C (+131 °F), Sea Level - GP 7200 Engines

**ON A/C A380-800 Models A380-800F Models

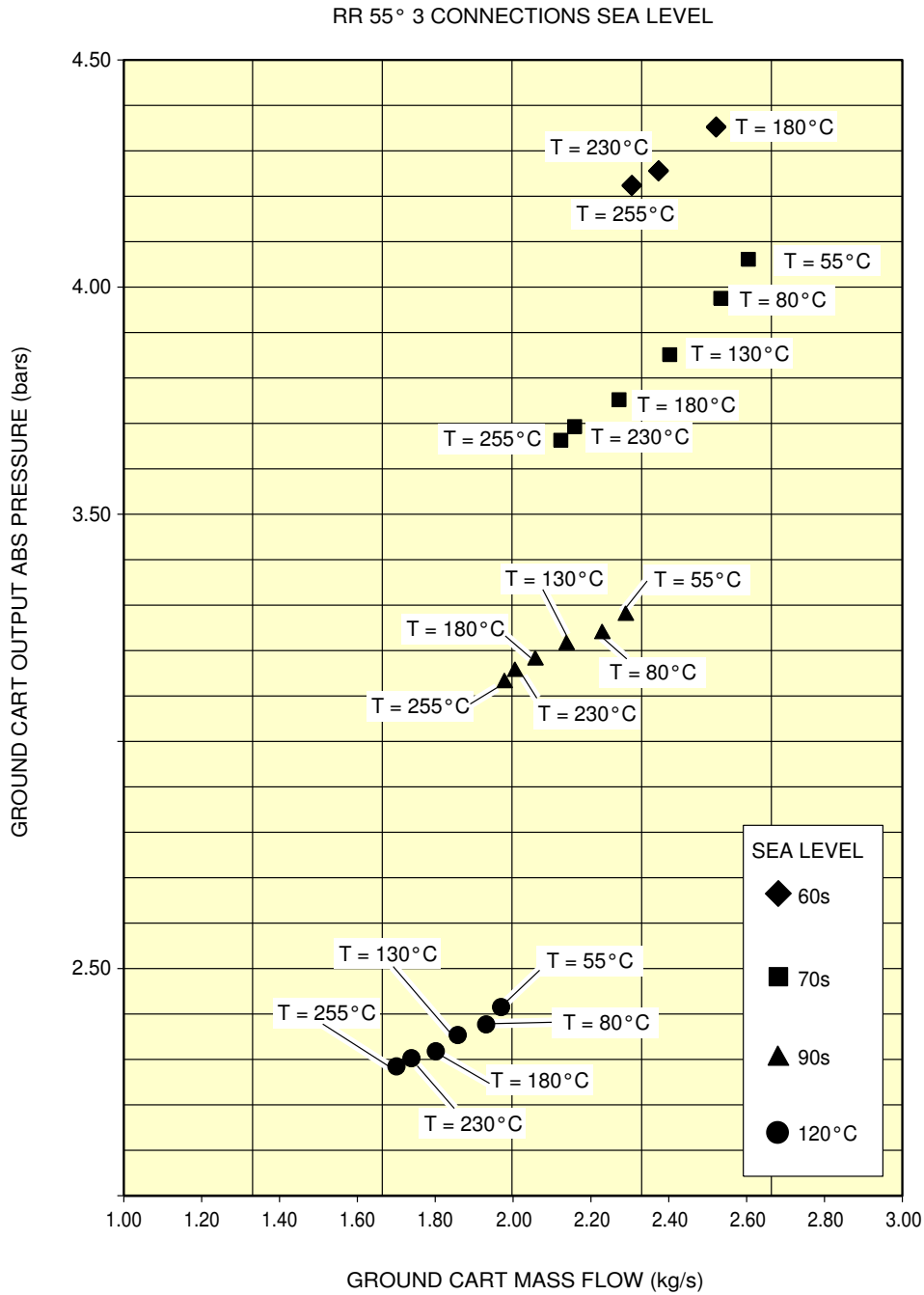

L_AC_050503_1_0030101_01_00

Engine Starting Pneumatic Requirements (three high pressure ground carts)
Ambient Temperature +55 °C (+131 °F), Sea Level - TRENT 900 Engines

**ON A/C A380-800 Models A380-800F Models

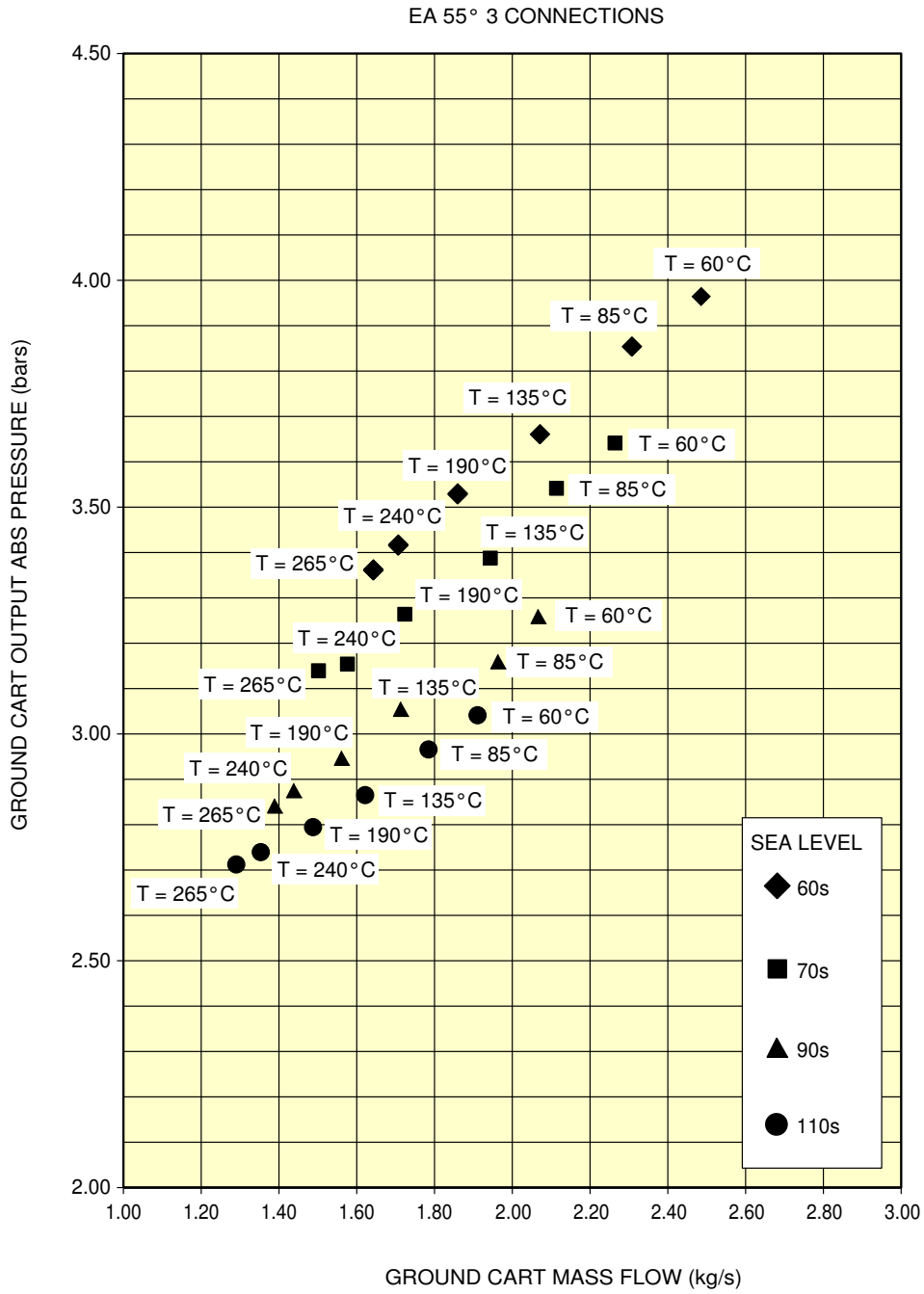

L_AC_050503_1_0040101_01_00

Engine Starting Pneumatic Requirements (three high pressure ground carts)
 Ambient Temperature +55 °C (+131 °F), Sea Level - GP 7200 Engines



AIRPLANE CHARACTERISTICS

5-6-0 Ground Pneumatic Power Requirements

****ON A/C A380-800 Models A380-800F Models**

Ground Pneumatic Power Requirements

1. Ground Pneumatic Power Requirements



AIRPLANE CHARACTERISTICS

5-6-1 Heating

****ON A/C A380-800 Models A380-800F Models**

Heating

1. This section provides the ground pneumatic power requirements heating.

****ON A/C A380-800 Models**

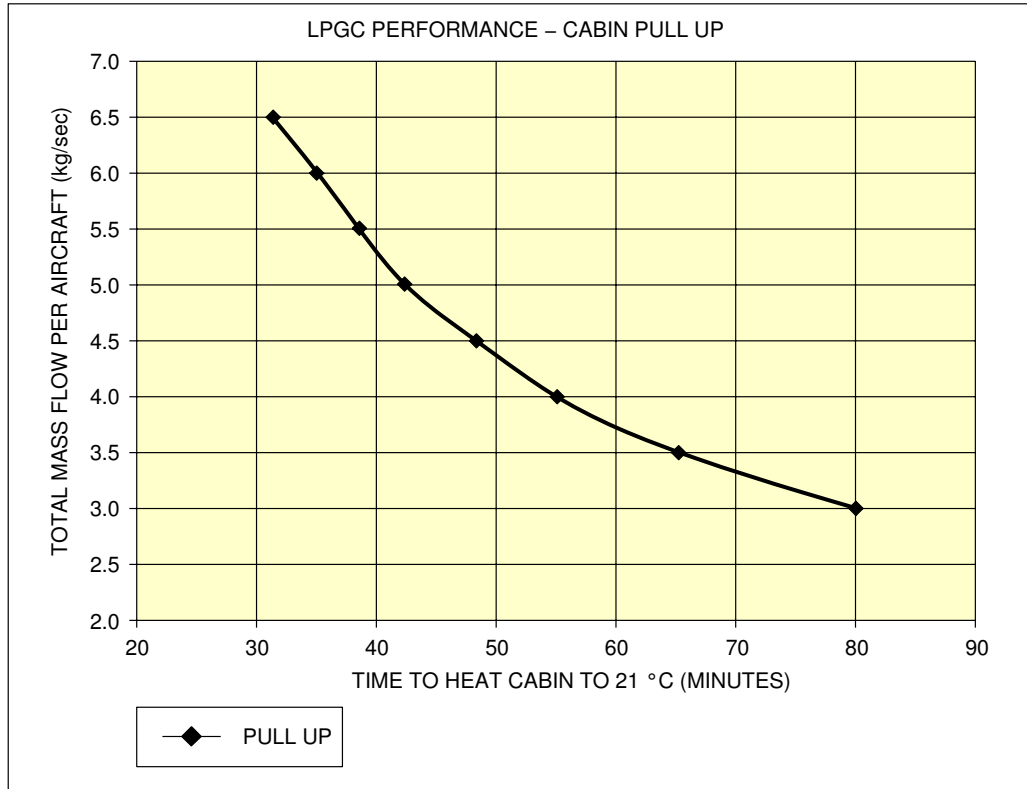

PULL UP: INITIAL CABIN TEMPERATURE AT -23 °C, HEAT UP TO 21 °C ON GROUND, TEMPERATURE AT THE GROUND CONNECTION: 70 °C

TOTAL LPGC AIR FLOW	TIME TO HEAT CABIN TO 21 °C (69.8 °C) ON GROUND PULL UP
kg/sec	min
3.0	80
3.5	65
4.0	55
4.5	48
5.0	42.5
5.5	38
6.0	35
6.5	31.6

L_AC_050601_1_0010101_01_00

Ground Pneumatic Power Requirements Heating
 Ground Pneumatic Power Requirements Heating - A380-800 Models

****ON A/C A380-800F Models**

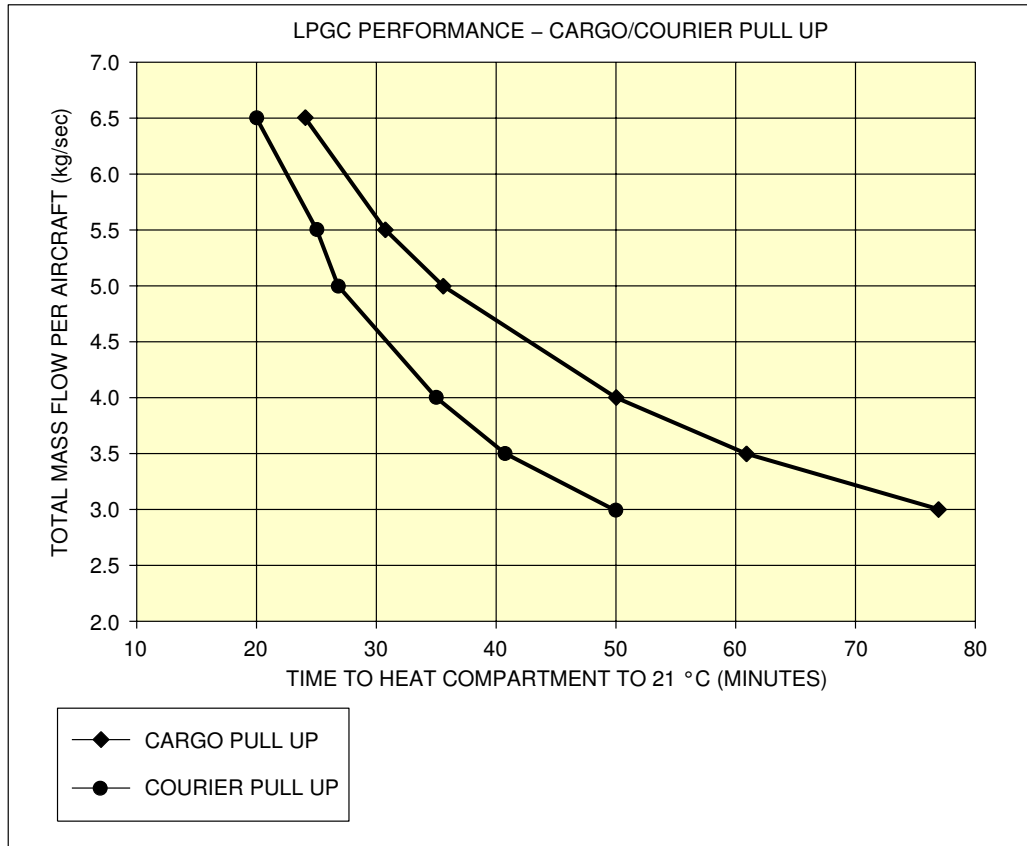

INITIAL TEMPERATURE AT -23°C OAT, COURIER AND CARGO COMPARTMENT HEATING TO 21 °C, ASSUMED LPGC INLET TEMPERATURE 70°C.

TOTAL LPGC AIR FLOW [kg/sec]	PULL UP TIME [min]	
	CARGO	COURIER
3.0	77	50
3.5	61	41
4.0	50	35
5.0	36	27
5.5	31	25
6.5	24	20

L_AC_050601_1_0020101_01_00

Ground Pneumatic Power Requirements Heating
Ground Pneumatic Power Requirements Heating - A380-800F Models



AIRPLANE CHARACTERISTICS

5-6-2 Cooling

****ON A/C A380-800 Models A380-800F Models**

Cooling

1. This section provides the ground pneumatic power requirements cooling.

****ON A/C A380-800 Models**

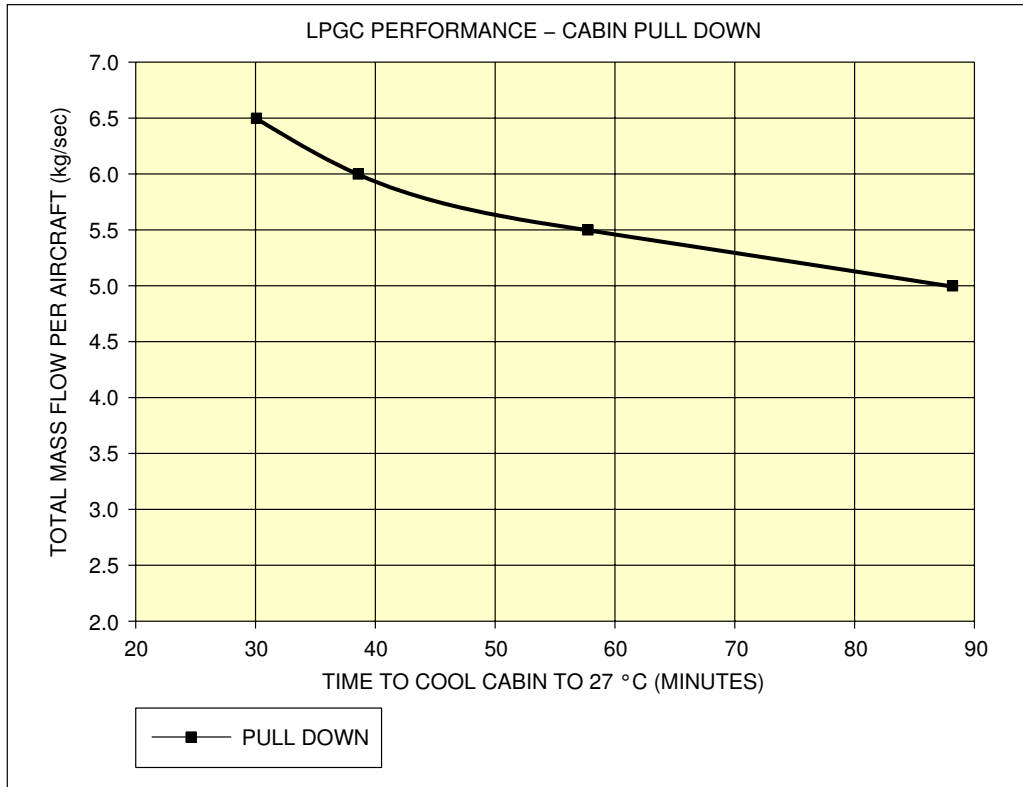

SAME BOUNDARY CONDITIONS AS BEFORE

(IN ADDITION BLENDS DOWN FOR THE PULL DOWN CASE), HP AND LP FANS ON

PULL DOWN: INITIAL CABIN TEMPERATURE AT 38 °C, COOL DOWN TO 27 °C ON GROUND

TEMPERATURE AT THE GROUND CONNECTION: 1.5 °C

TOTAL LPGC AIR FLOW	TIME TO COOL CABIN TO 27 °C (80.6 °C) ON GROUND PULL DOWN
kg/sec	min
3.0	-
3.5	-
4.0	-
4.5	-
5.0	87
5.5	58
6.0	38
6.5	30

L_AC_050602_1_0010101_01_00

Ground Pneumatic Power Requirements Cooling
 Ground Pneumatic Power Requirements Cooling - A380-800 Models

****ON A/C A380-800F Models**

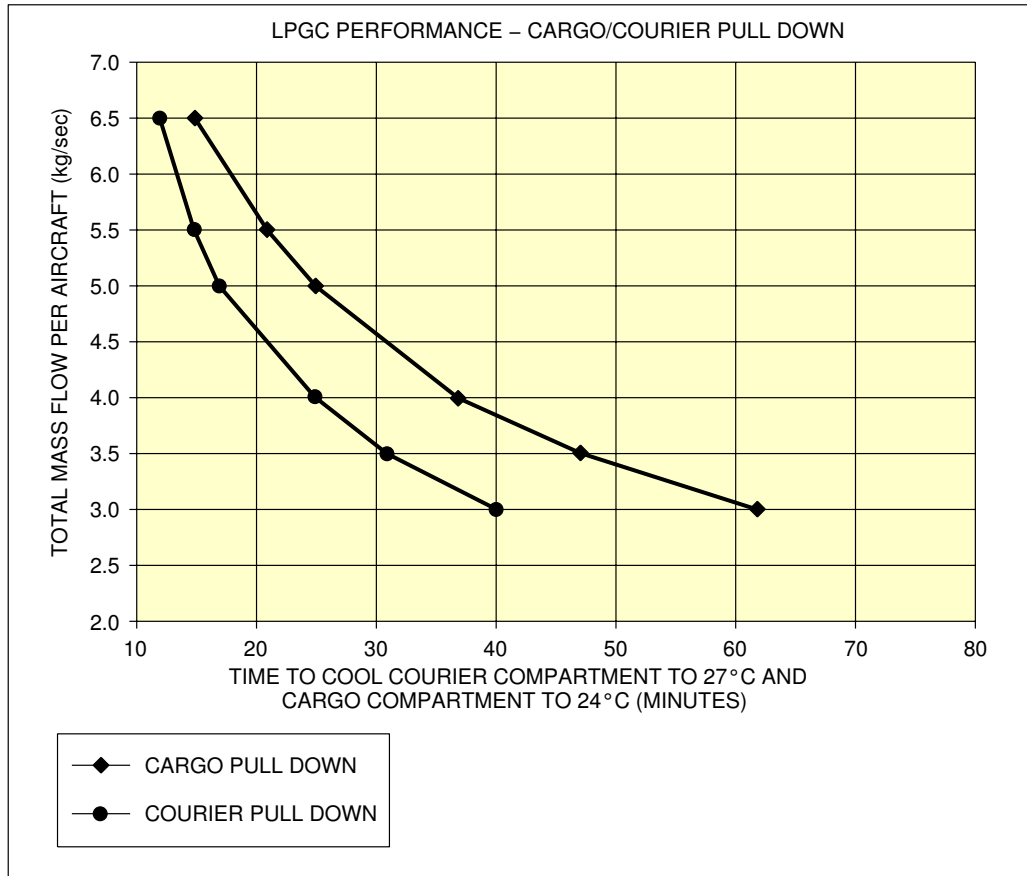

INITIAL TEMPERATURE AT 38°C OAT, COURIER COMPARTMENT COOL DOWN TO 27°C AND CARGO COMPARTMENT COOL DOWN TO 24°C, ASSUMED LPGC INLET TEMPERATURE 1.5°C

TOTAL LPGC AIR FLOW [kg/sec]	PULL DOWN TIME [min]	
	CARGO	COURIER
3.0	62	40
3.5	47	31
4.0	37	25
5.0	25	17
5.5	21	15
6.5	15	12

L_AC_050602_1_0020101_01_00

Ground Pneumatic Power Requirements Cooling
Ground Pneumatic Power Requirements Cooling - A380-800F Models



AIRPLANE CHARACTERISTICS

5-7-0 Preconditioned Airflow Requirements

****ON A/C A380-800 Models A380-800F Models**

Preconditioned Airflow Requirements

1. This section provides the preconditioned airflow requirements.

****ON A/C A380-800 Models**

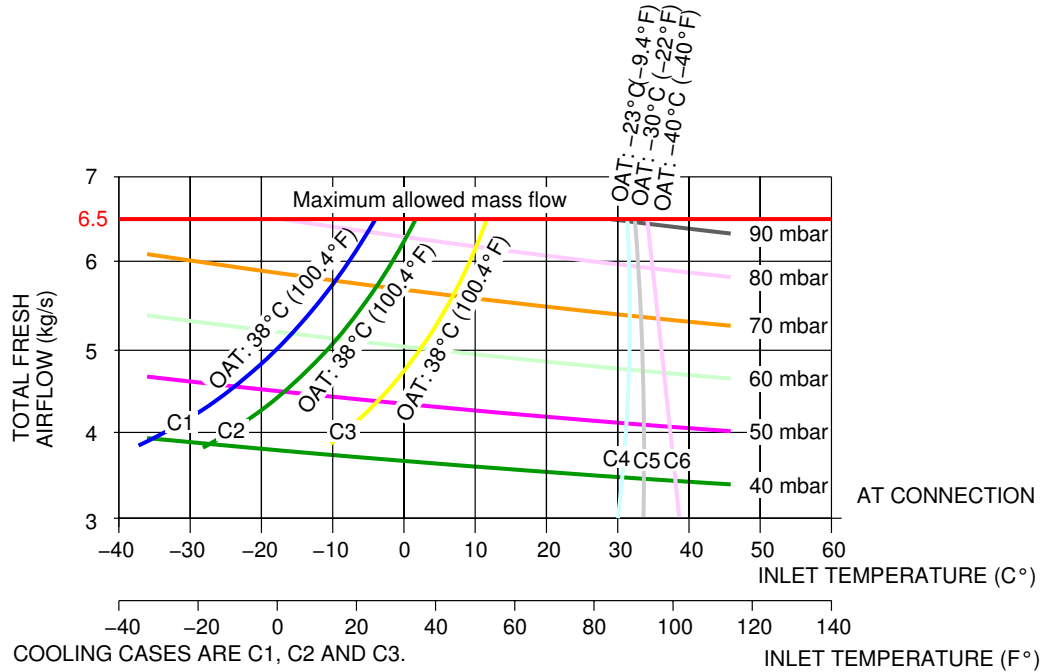

COOLING CASES ARE C1, C2 AND C3.
HEATING CASES ARE C4, C5 AND C6.

C1 CURVE ASSUMES:

- LPGC AIR AT 45% RH
- AIRCRAFT CONFIGURED IN STANDARD ZONES
- CABIN TEMPERATURE: 27°C (80.6°F)
- MAX. PASSENGER LOAD, 19 ATTENDANTS, 5 CREW MEMBERS
- HP RECIRCULATION: ON (HP FILTER CONDITION: NEW CARTRIDGE)
- SOLAR RADIATION IS INCLUDED IN CALCULATIONS
- IFE: ON
- VIDEO OPERATION 75%, PC OPERATION 13%
- BOTH AVIONIC VALVES OFF
- CARGO VALVES ON (CARGO FLOW SETTING NORMAL)

C2 CURVE ASSUMES:

- SAME CONDITIONS AS C1 BUT WITH IFE OFF VIDEO OPERATION 0% PC OPERATION 0%

C3 CURVE ASSUMES:

- SAME CONDITIONS AS C1 BUT WITHOUT PASSENGERS

C4, C5 AND C6 CURVES ASSUME:

- LPGC AIR AT 45% RH
- AIRCRAFT CONFIGURED IN STANDARD ZONES
- CABIN TEMPERATURE: 21°C (69.8°F)
- NO PASSENGER, 0 ATTENDANT, 0 CREW MEMBER
- HP RECIRCULATION: ON (HP FILTER CONDITION: NEW CARTRIDGE)
- SOLAR RADIATION IS NOT INCLUDED
- IFE: OFF
- VIDEO OPERATION 0%, PC OPERATION 0%
- CABIN LIGHTING OFF, GALLEY POWER OFF
- BOTH AVIONIC VALVES OFF
- CARGO VALVES OFF (CARGO FLOW SETTING NORMAL)

NOTE: IFE = IN-FLIGHT ENTERTAINMENT SYSTEM.
OAT = OUTSIDE AIR TEMPERATURE.

L_AC_050700_1_0010101_01_00

Preconditioned Airflow Requirements
Preconditioned Airflow Requirements - A380-800 Models

**ON A/C A380-800F Models

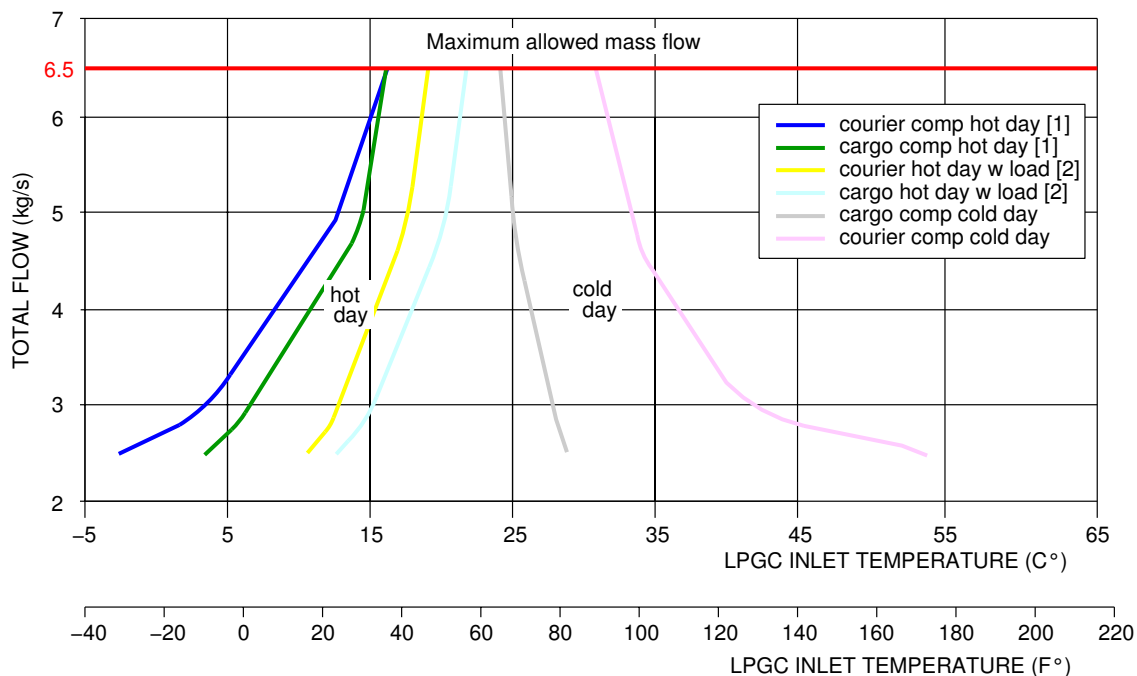

COOLING CASES [1] ASSUMES:

- HOT DAY (ISA +23°)
- STANDARD AIRFLOW DISTRIBUTION
- STABILIZED CARGO COMPARTMENT TEMPERATURE 24°C, COURIER COMPARTMENT 27°C
- NO OCCUPANT LOAD, EMPTY CARGO COMPARTMENT
- NO HIGH PRESSURE RECIRCULATION, LOW PRESSURE RECIRC ON
- LOWER DECK CARGO: VENTILATION ONLY

COOLING CASE [2] WITH COMPARTMENT LOADS:

- SAME AS COOLING [1], BUT MAX COURIER LOAD AND 3kW TRANSPORT LOAD PER CARGO COMPARTMENT

HEATING CASE ASSUMES:

- COLD DAY (ISA -38°C)
- STANDARD AIRFLOW DISTRIBUTION
- STABILIZED CARGO AND COURIER COMPARTMENT TEMPERATURE 21°C
- NO OCCUPANT LOAD, EMPTY CARGO COMPARTMENT
- NO HIGH PRESSURE RECIRCULATION, LOW PRESSURE RECIRC ON
- LOWER DECK CARGO: VENTILATION ONLY

TOTAL FLOW LIMIT AT 6,5 KG/S DUE TO CPCS (CABIN PRESSURE CONTROL SYSTEM), MAX RESIDUAL PRESSURE 2MBAR WITH CLOSED DOORS

L_AC_050700_1_0020101_01_00

Preconditioned Airflow Requirements
Preconditioned Airflow Requirements - A380-800F Models



AIRPLANE CHARACTERISTICS

5-8-0 Ground Towing Requirements

****ON A/C A380-800 Models**

Ground Towing Requirements

1. General

This section gives Ground Towing Requirements.

**ON A/C A380-800 Models

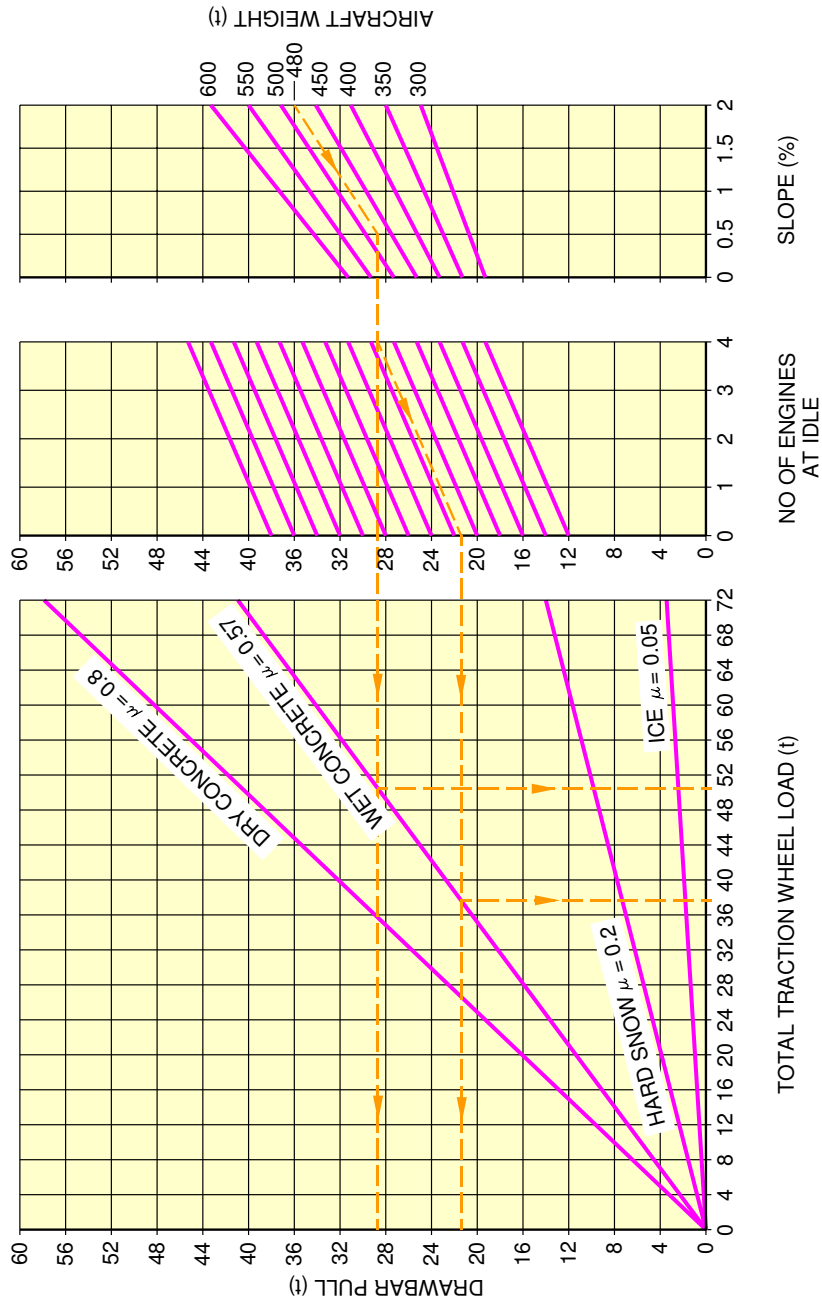

--- EXAMPLE

NOTE: - UNUSUAL BREAKAWAY CONDITIONS NOT SHOWN
 - STRAIGHT-LINE TOW

L_AC_050800_1_0010101_01_01

Ground Towing Requirements
 A380-800 Models

OPERATING CONDITIONS**6-1-0 Engine Exhaust Velocities and Temperatures******ON A/C A380-800 Models A380-800F Models**Engine Exhaust Velocities and Temperatures

1. General

This section shows the estimated engine exhaust efflux velocity and temperature contours for Maximum Take-off, Breakaway and Idle conditions for the A380 engine models.

Contours are available for both Rolls-Royce's Trent 900 engine and the Engine Alliance's GP7200 engine.

The Maximum Take-off data are presented at the maximum thrust rating for all the A380 engine models, including the A380-800F Freighter version. Therefore, contours hereafter include contours of the A380-800 Passenger version.

The Breakaway data are presented at a rating corresponding to the minimum thrust level required to initiate movement of an A380-800F model at its maximum ramp weight from static position and on uphill ground.

The Idle data are directly provided by the engine manufacturers.

In the charts, longitudinal distances are measured from the inboard engine core nozzle exit station, while lateral distances are measured from the aircraft fuselage centreline.

A. Data from Rolls-Royce's Trent 900:

The estimated efflux data are presented at ISA+15 °C (30 °C), Sea Level Static and negligible wind conditions.

The analysis assumes that the core and bypass streams are fully mixed and calculates the jet behaviour in free, still air and therefore does not take into account effects such as on-wing installation, ground entrainment and ambient wind conditions.

Velocity contours are presented at 50 ft/s (15 m/s), 100 ft/s (30 m/s) and 150 ft/s (46 m/s), while temperature contours are presented at 104 °F (40 °C), 122 °F (50 °C) and 172 °F (60 °C).

B. Data from Engine Alliance's GP7200:



AIRPLANE CHARACTERISTICS

The estimated efflux data are presented at ISA+15 °C (30 °C), Sea Level Static with 20 kt headwind. It also assumed ground plane and proximity effects. Velocity contours are presented at 35 MPH (15 m/s), 65 MPH (30 m/s) and 105 MPH (46 m/s), while temperature contours are presented at 122 °F (50 °C), 212 °F (100 °C) and 392 °F (200 °C). Engine Alliance strongly recommends that jet blast studies using their contours include the effect of a 20-knot headwind.



AIRPLANE CHARACTERISTICS

6-1-1 Engine Exhaust Velocities - Ground Idle Power

****ON A/C A380-800 Models A380-800F Models**

Engine Exhaust Velocities - Ground Idle Power

1. This section gives engine exhaust velocities at ground idle power.

****ON A/C A380-800 Models A380-800F Models**

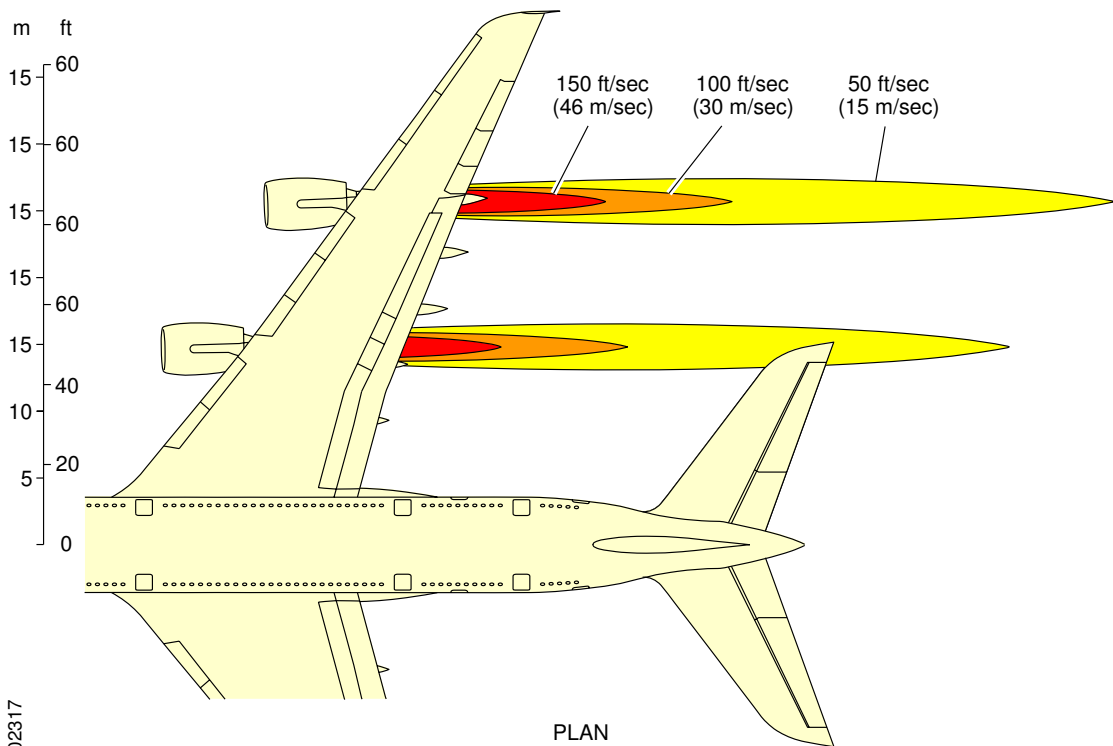
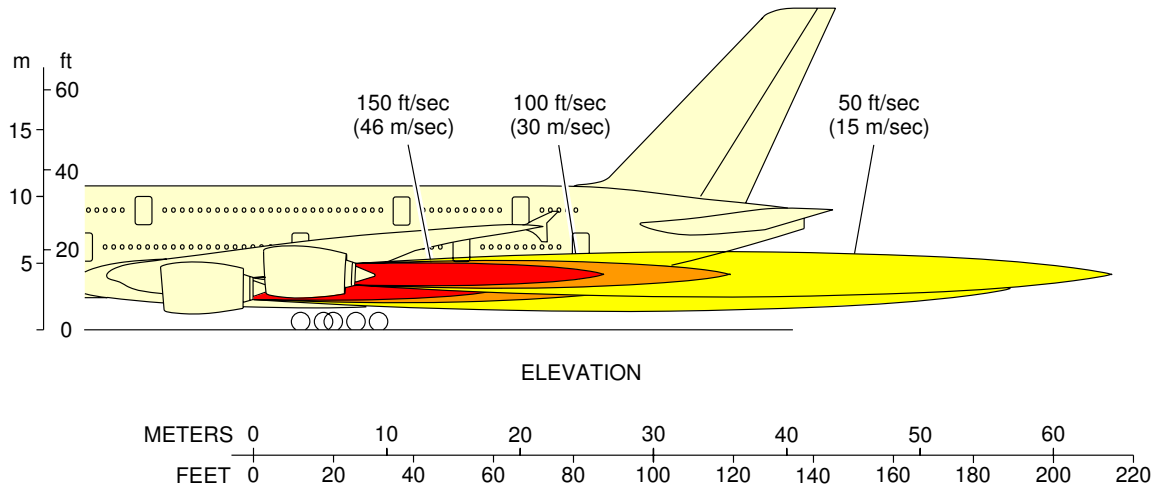

deh0002317

L_AC_060101_1_0010101_01_00

Engine Exhaust Velocities
Ground Idle Power - TRENT 900 Engines

****ON A/C A380-800 Models A380-800F Models**

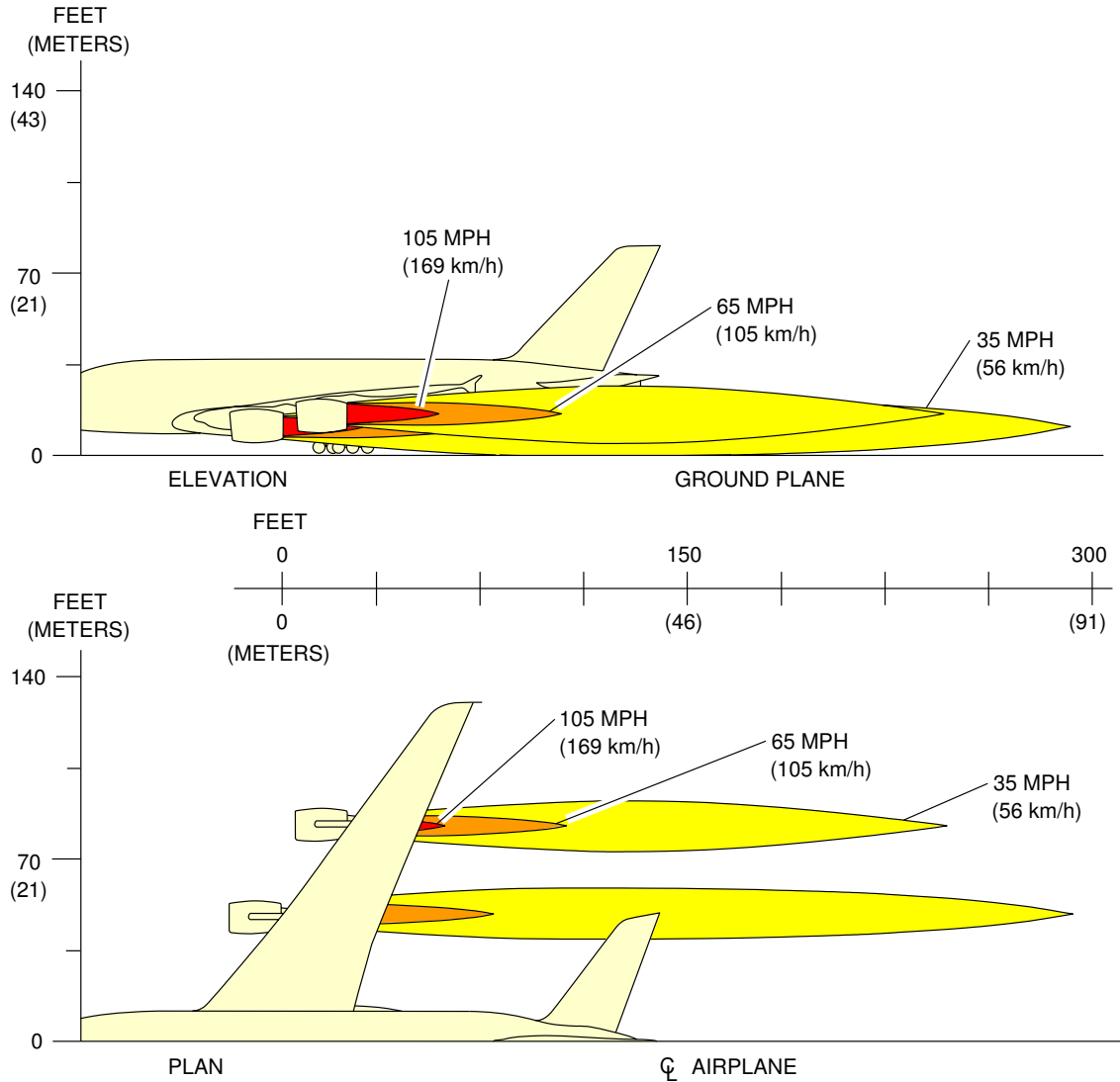

E-00224 (0207)
PW V

NOTE: ALL VELOCITY VALUES ARE IN STATUE MILES PER HOUR.
CONVERSION FACTOR
1 MPH = 1.6 km/h
DANGER (KEEP OUT) ZONES \geq 35 MPH

L_AC_060101_1_0020101_01_01

Engine Exhaust Velocities
Ground Idle Power - GP 7200 Engines



AIRPLANE CHARACTERISTICS

6-1-2 Engine Exhaust Temperatures - Ground Idle Power

****ON A/C A380-800 Models A380-800F Models**

Engine Exhaust Temperatures - Ground Idle Power

1. This section gives engine exhaust temperatures at ground idle power.

**ON A/C A380-800 Models A380-800F Models

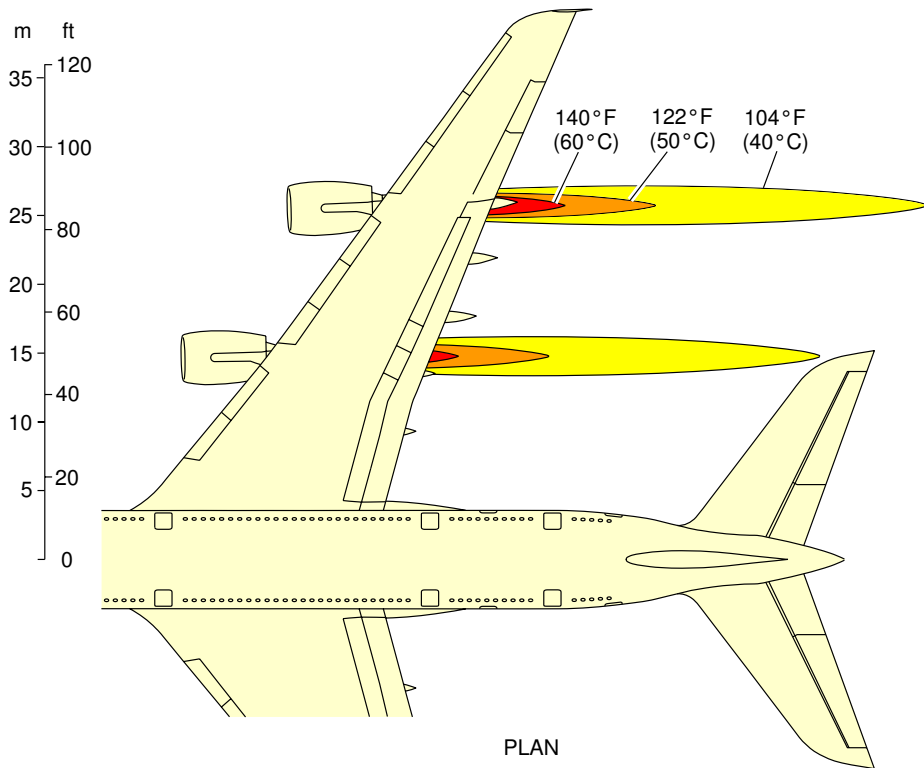
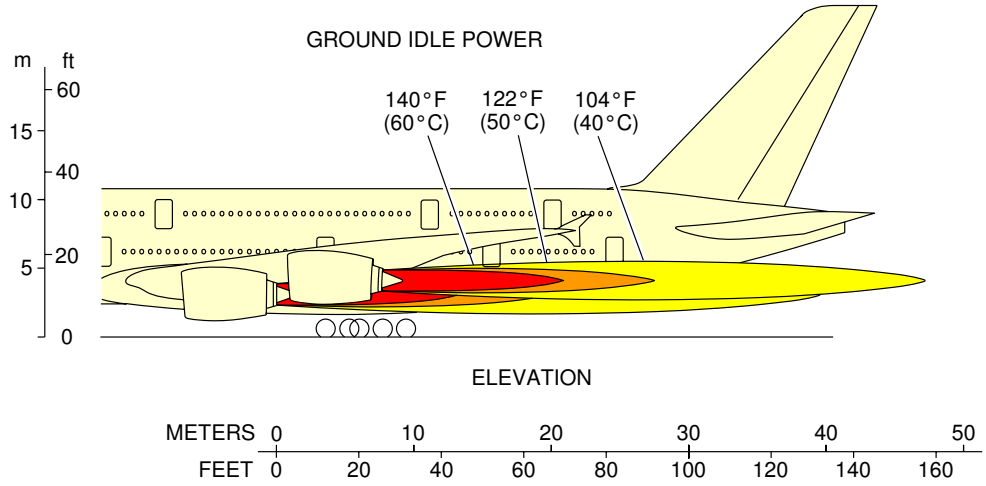

deh0002316

L_AC_060102_1_0010101_01_01

Engine Exhaust Temperatures
Ground Idle Power - TRENT 900 Engines

****ON A/C A380-800 Models A380-800F Models**

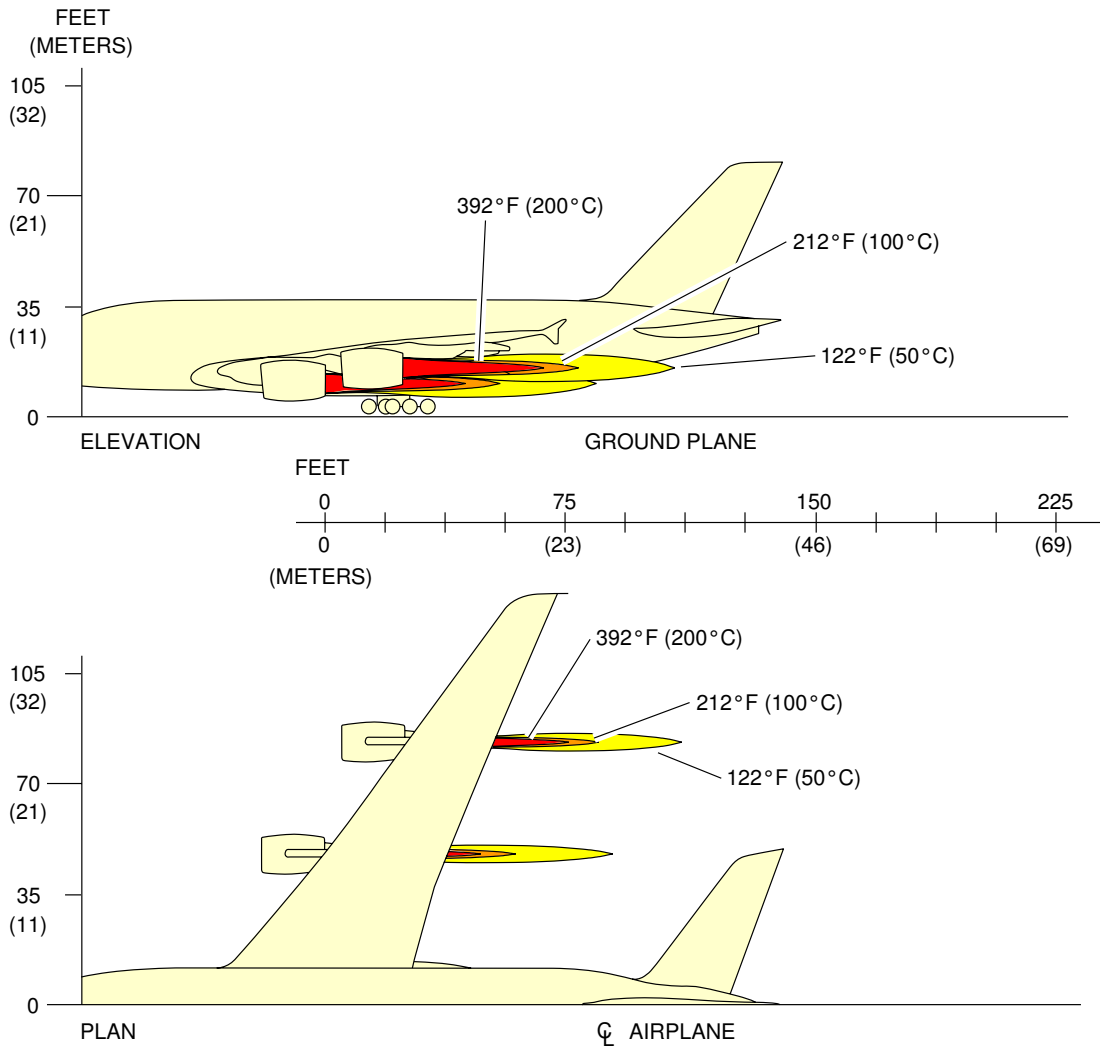

NOTE: ALL TEMPERATURES ARE IN FAHRENHEIT (CELSIUS).

E-00226 (0207)
PW V

L_AC_060102_1_0020101_01_01

Engine Exhaust Temperatures
 Ground Idle Power - GP 7200 Engines



AIRPLANE CHARACTERISTICS

6-1-3 Engine Exhaust Velocities - Breakaway Power

****ON A/C A380-800 Models A380-800F Models**

Engine Exhaust Velocities - Breakaway Power

1. This section gives engine exhaust velocities at breakaway power.

**ON A/C A380-800 Models A380-800F Models

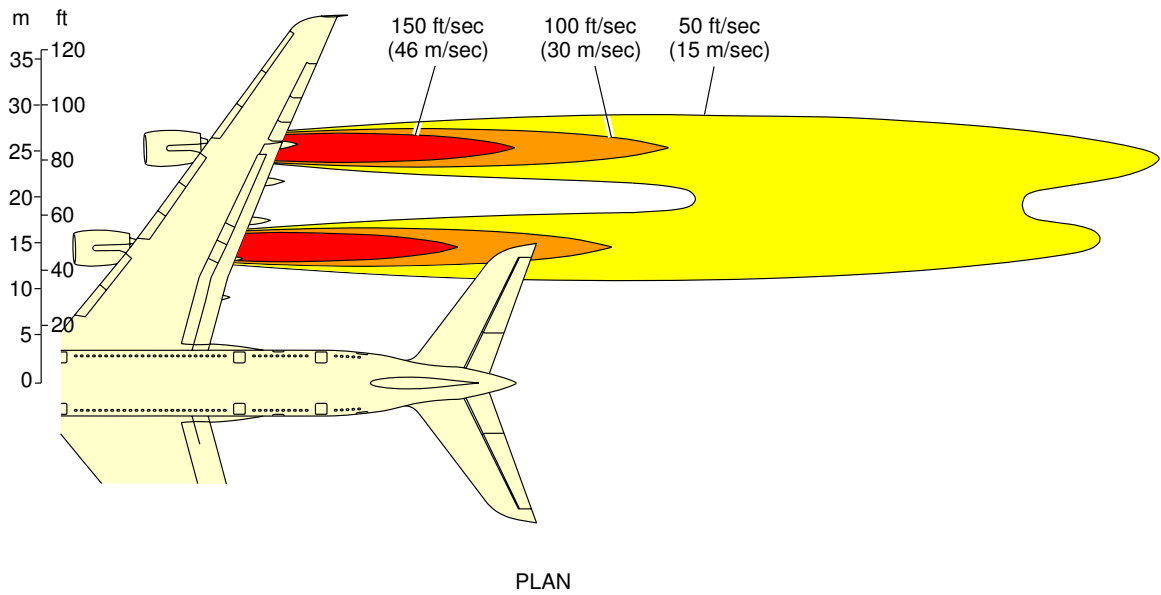
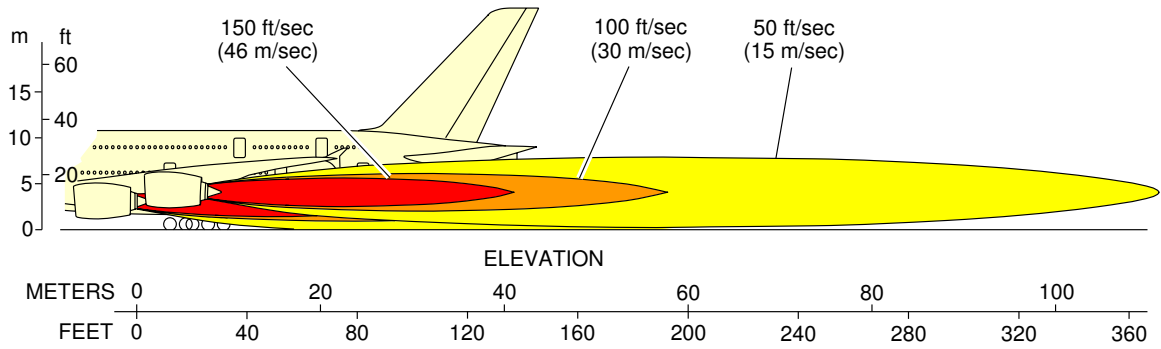

deh0002319

L_AC_060103_1_0010101_01_00

Engine Exhaust Velocities
Breakaway Power - TRENT 900 Engines

**ON A/C A380-800 Models A380-800F Models

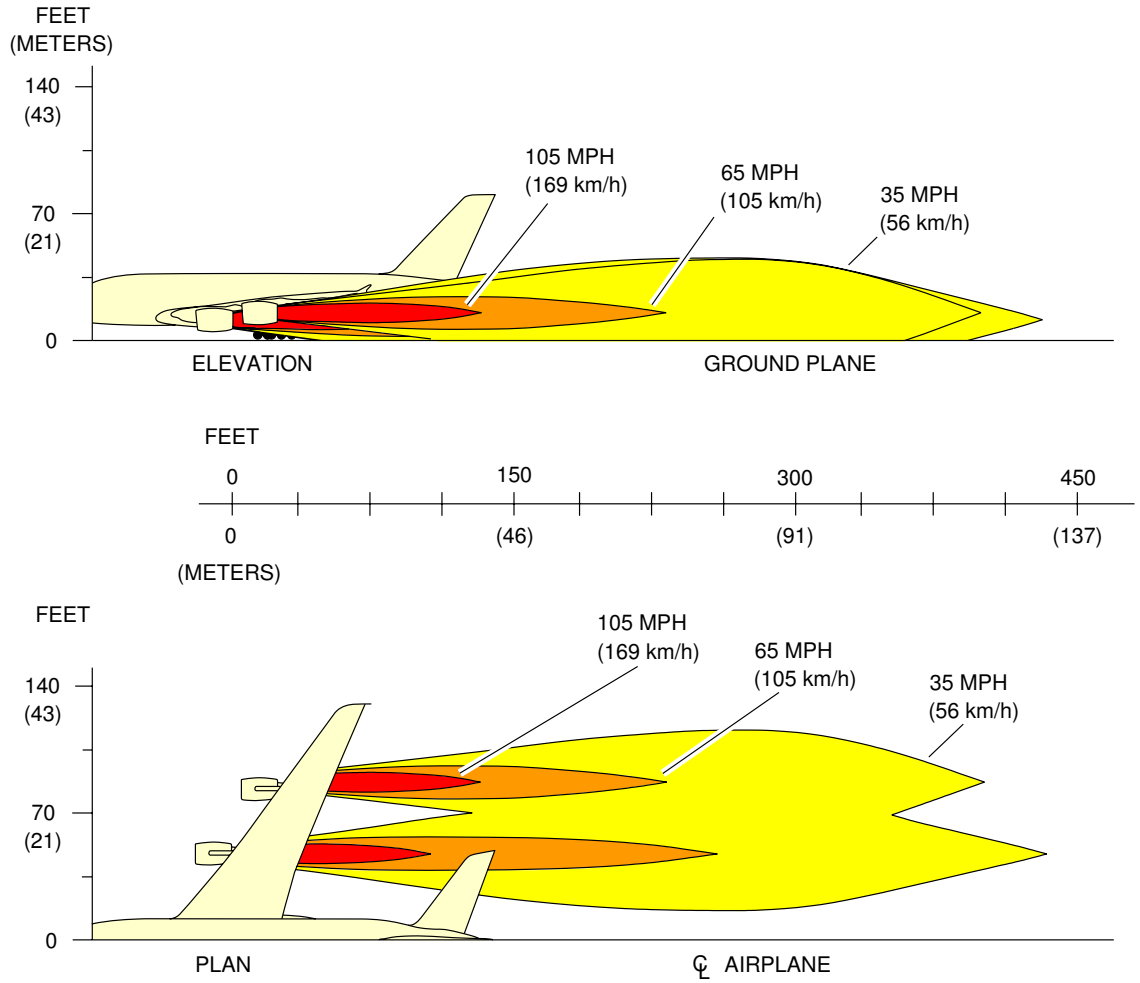

E-02200 (0207)
PWV

NOTE: ALL VELOCITY VALUES ARE IN STATUE MILES PER HOUR.
CONVERSION FACTOR
1 MPH = 1.6 km/h
DANGER (KEEP OUT) ZONES \geq 35 MPH

L_AC_060103_1_0020101_01_01

Engine Exhaust Velocities
Breakaway Power - GP 7200 Engines



AIRPLANE CHARACTERISTICS

6-1-4 Engine Exhaust Temperatures - Breakaway Power

**ON A/C A380-800 Models A380-800F Models

Engine Exhaust Temperatures - Breakaway Power

1. This section gives engine exhaust temperatures at breakaway power.

****ON A/C A380-800 Models A380-800F Models**

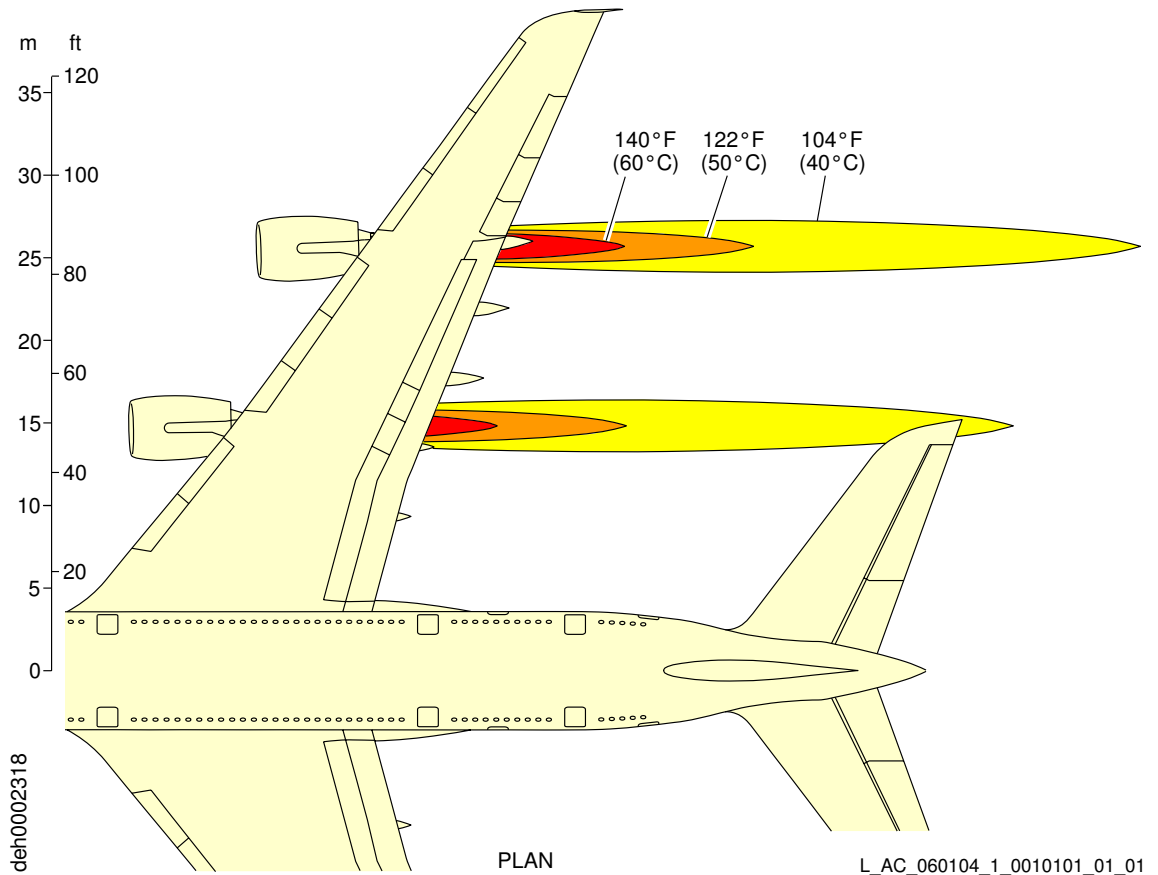
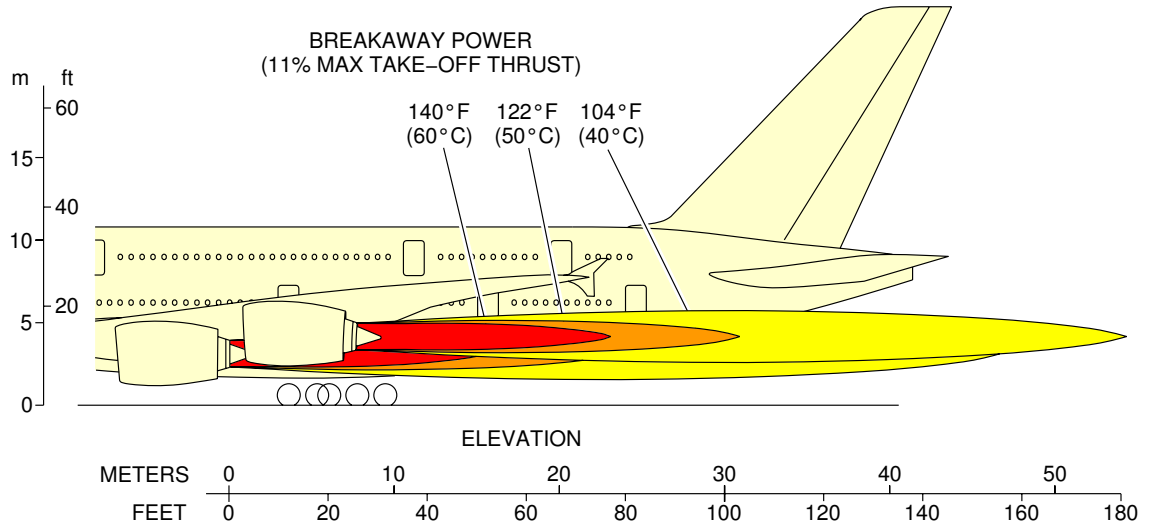

Engine Exhaust Temperatures
Breakaway Power - TRENT 900 Engines

****ON A/C A380-800 Models A380-800F Models**

E-02201 (0805)
PW V

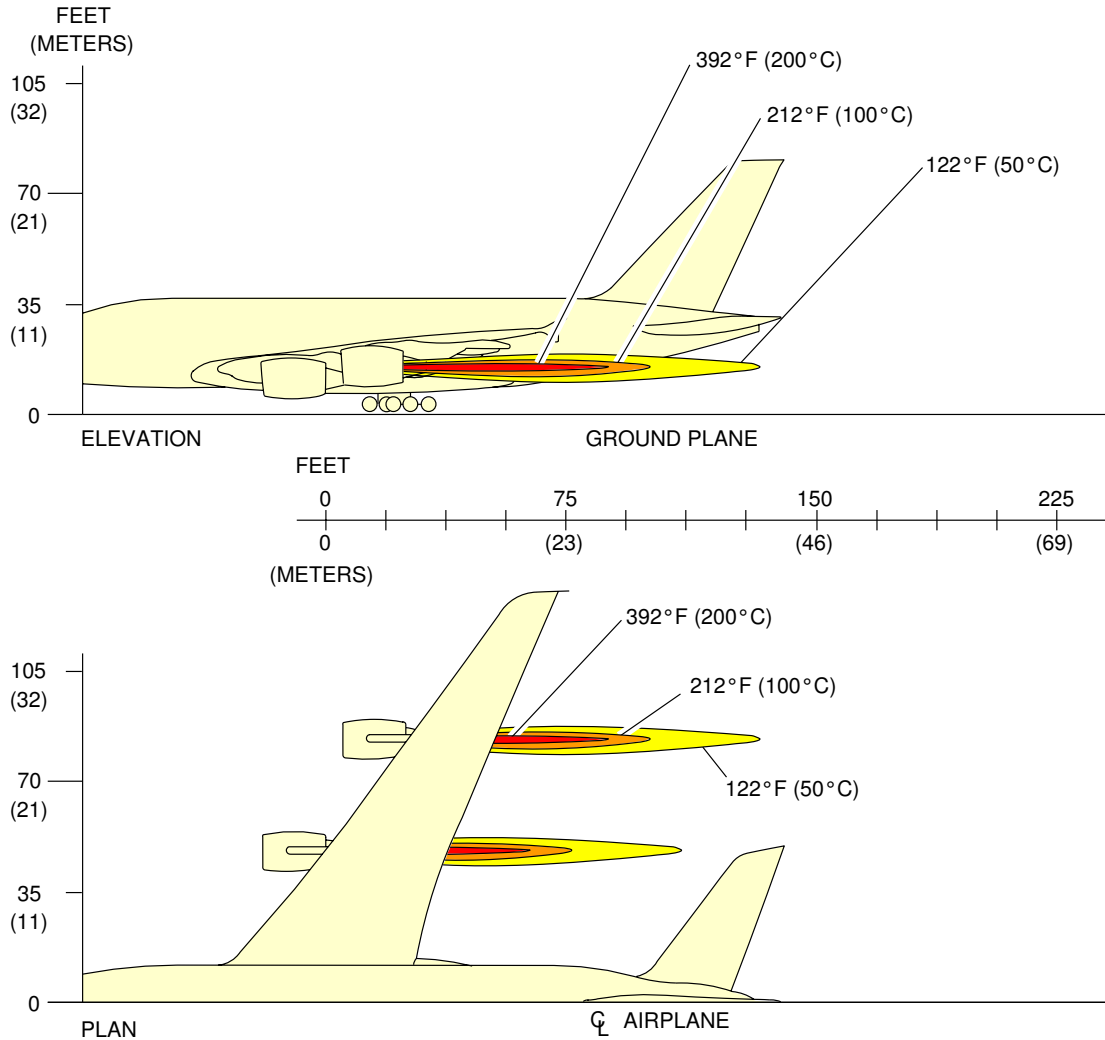

NOTE : ALL TEMPERATURES ARE IN FAHRENHEIT (CELSIUS).

L_AC_060104_1_0020101_01_00

Engine Exhaust Temperatures
Breakaway Power - GP 7200 Engines



AIRPLANE CHARACTERISTICS

6-1-5 Engine Exhaust Velocities - Max Take-off Power

****ON A/C A380-800 Models A380-800F Models**

Engine Exhaust Velocities - Max Take-off Power

1. This section gives engine exhaust velocities at max take-off power.

**ON A/C A380-800 Models A380-800F Models

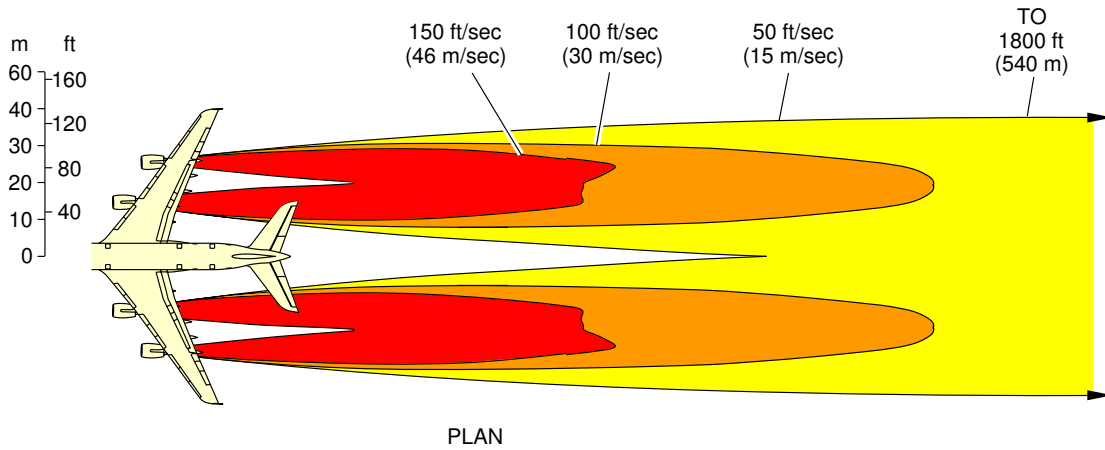
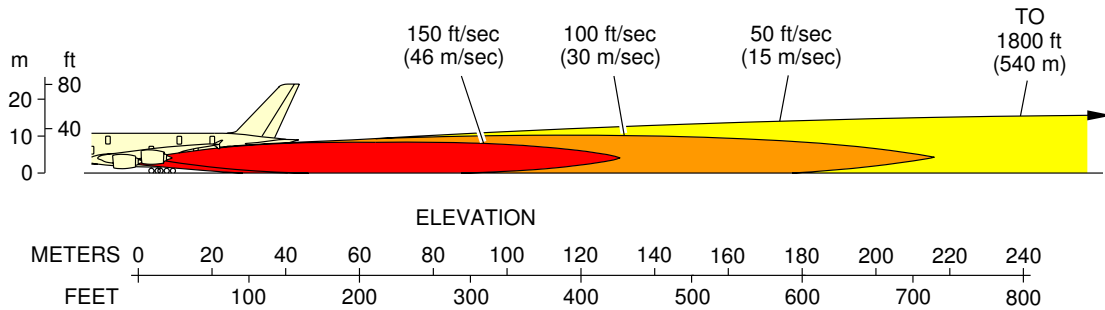

deh0002315

L_AC_060105_1_0010101_01_00

Engine Exhaust Velocities
Max. Take-Off Power - TRENT 900 Engines

****ON A/C A380-800 Models A380-800F Models**

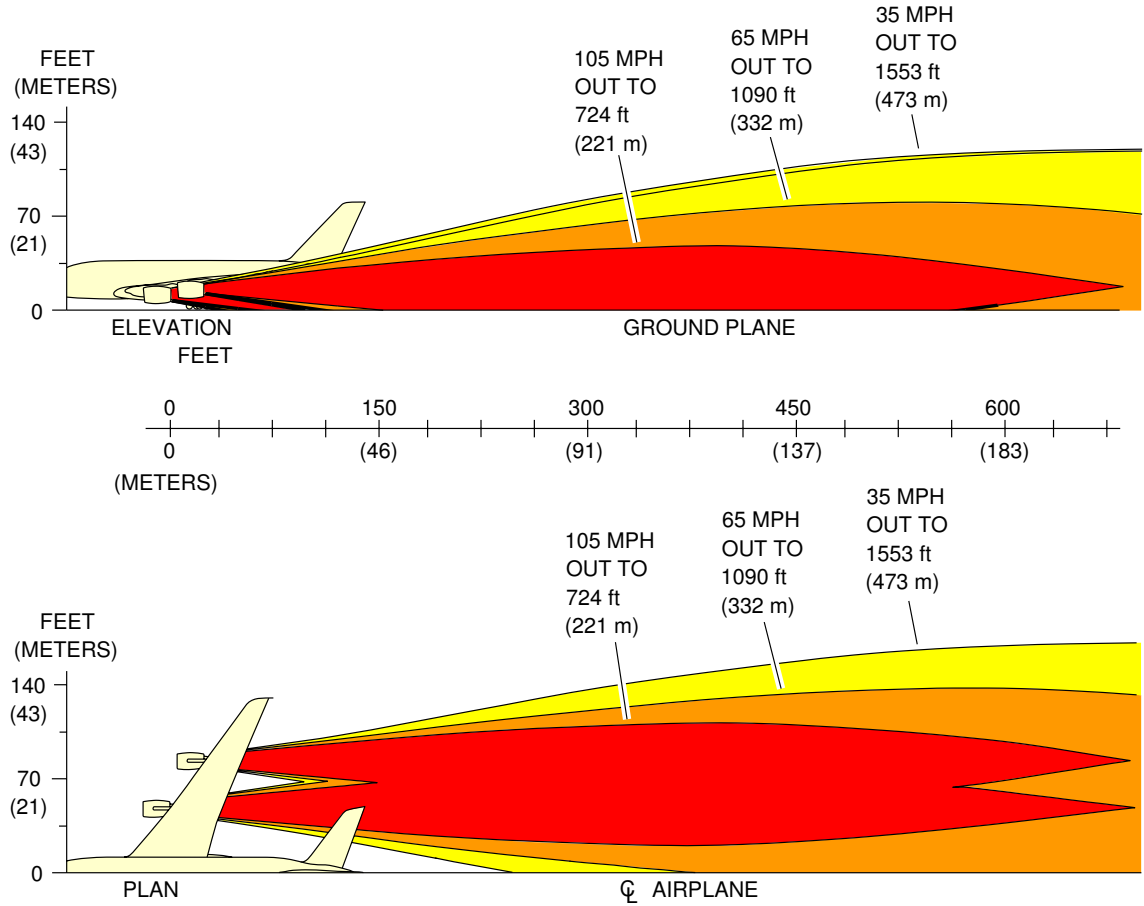

E-00225 (0207)
PW V

NOTE: ALL VELOCITY VALUES ARE IN STATUE MILES PER HOUR.
 CONVERSION FACTOR
 1 MPH = 1.6 km/h
 DANGER (KEEP OUT) ZONES \geq 35 MPH

L_AC_060105_1_0020101_01_01

Engine Exhaust Velocities
 Max. Take-Off Power - GP 7200 Engines



AIRPLANE CHARACTERISTICS

6-1-6 Engine Exhaust Temperatures - Max Take-off Power

****ON A/C A380-800 Models A380-800F Models**

Engine Exhaust Temperatures - Max Take-off Power

1. This section gives engine exhaust temperatures at max take-off power.

**ON A/C A380-800 Models A380-800F Models

MAX TAKE-OFF POWER

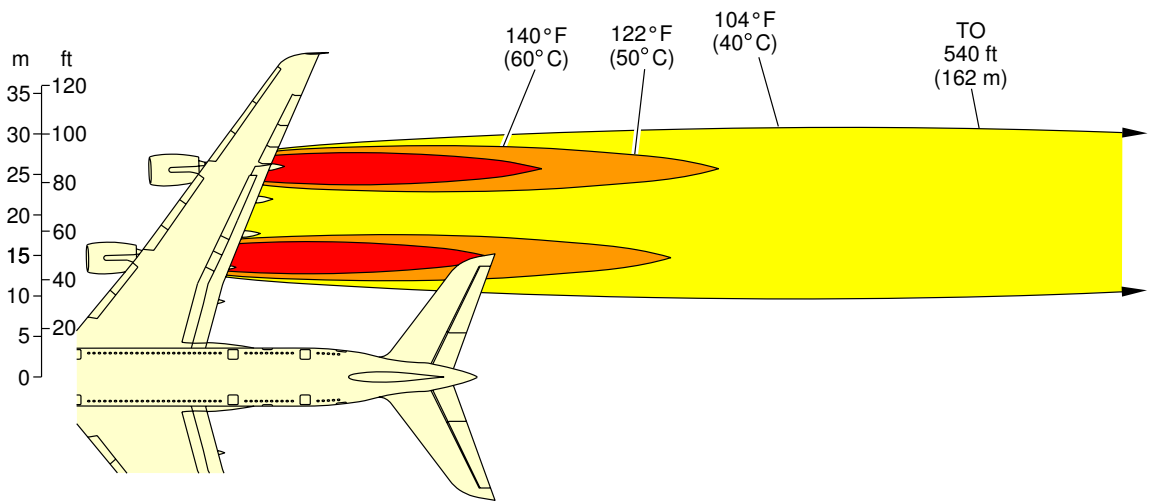
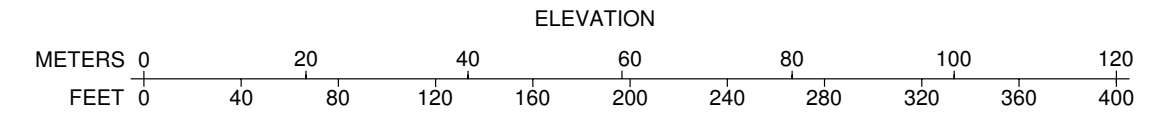
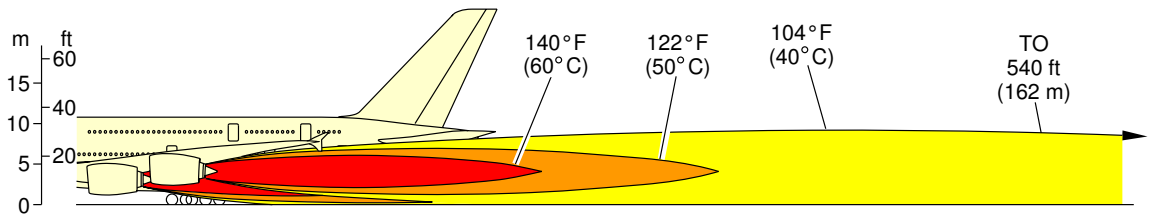

PLAN

deh0002314

L_AC_060106_1_0010101_01_01

Engine Exhaust Temperatures
Max Take-Off Power - TRENT 900 Engines

****ON A/C A380-800 Models A380-800F Models**

E-00227 (0704)
PW V

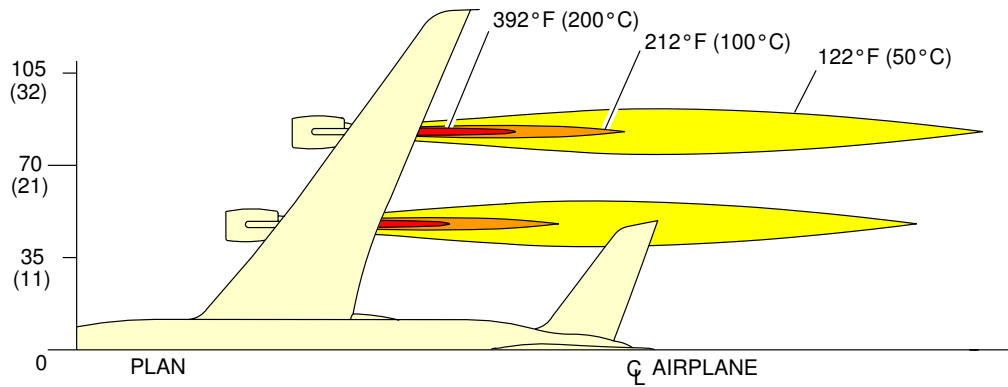
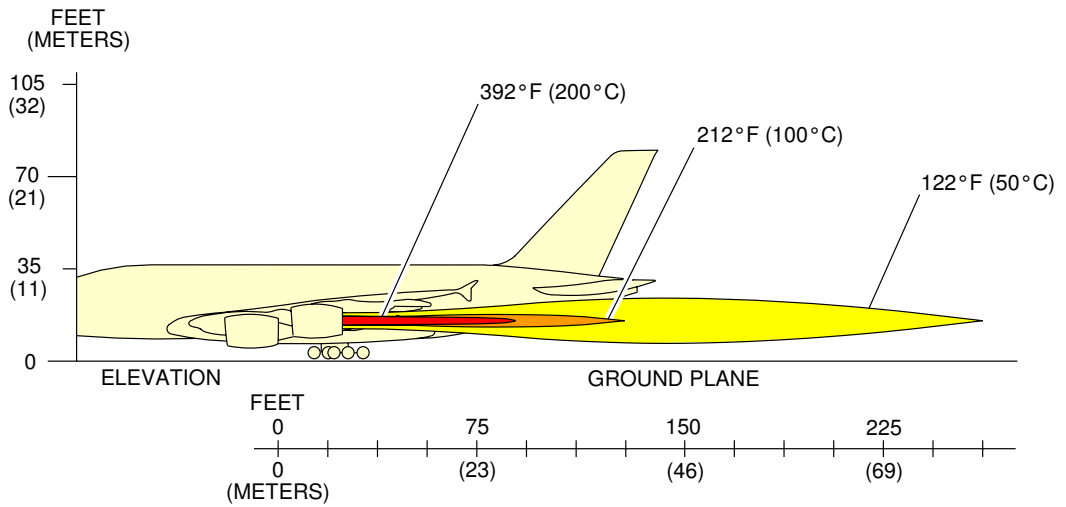

NOTE : ALL TEMPERATURES ARE IN FAHRENHEIT (CELSIUS).

L_AC_060106_1_0020101_01_00

Engine Exhaust Temperatures
Max Take-Off Power - GP 7200 Engines



AIRPLANE CHARACTERISTICS

6-2-0 Airport and Community Noise Data

**ON A/C A380-800 Models A380-800F Models

Airport and Community Noise Data

1. Airport and Community Noise Data

6-2-1 Airport and Community Noise Data****ON A/C A380-800 Models A380-800F Models**Airport and Community Noise Data

1. RR TRENT 900 Engines

A. Description of Test Conditions

The arc of circle (radius = 60m), with microphones 1.2 m high, is centered on the position of the noise reference point.

A.P.U. : off ; E.C.S. : Packs off.

B. Meteorological Data

The meteorological parameters measured 1.6 m from the ground on the day of test were as follows:

- Temperature: 32 ° C
- Relative humidity: 31%
- Atmospheric pressure: 996 hPa
- Wind speed: Negligible
- No rain

2. EA GP7200 Engines

A. Description of Test Conditions

The arc of circle (radius = 60m), with microphones 1.2 m high, is centered on the position of the noise reference point.



A.P.U. : off ; E.C.S. : Packs off.

B. Meteorological Data

The meteorological parameters measured 1.6 m from the ground on the day of test were as follows:

- Temperature: 12 ° C
- Relative humidity: 90%
- Atmospheric pressure: 1015 hPa
- Wind speed: Negligible
- No rain

**ON A/C A380-800 Models A380-800F Models

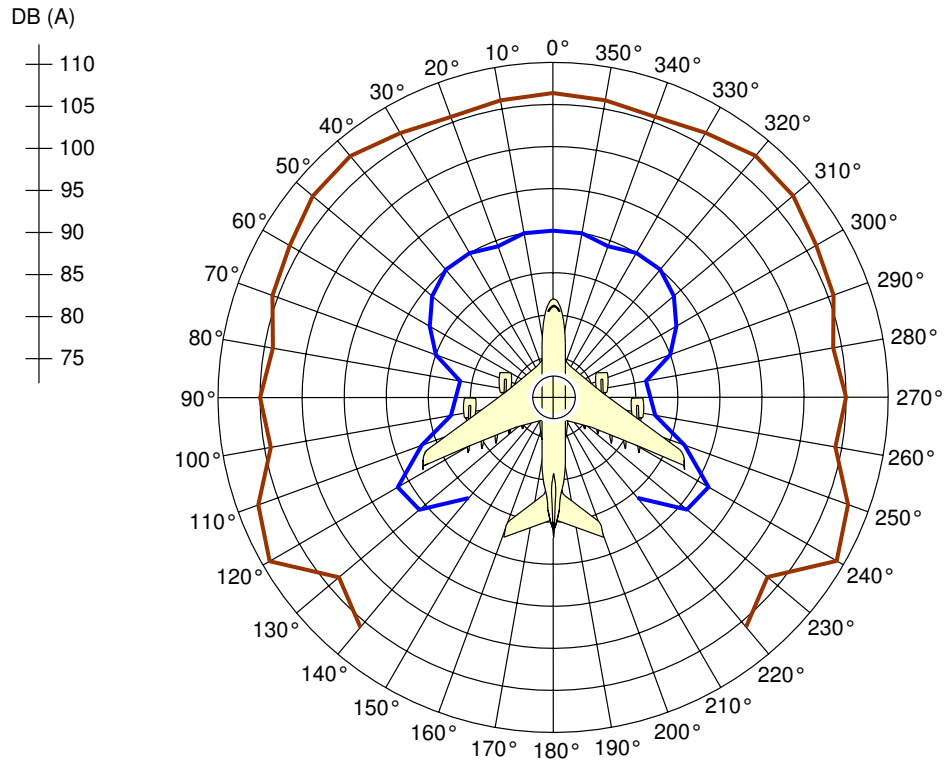

GROUND IDLE 4 ENGINES RUNNING	MAX THRUST POSSIBLE ON BRAKES 4 ENGINES RUNNING
	



L_AC_060201_1_0030101_01_01

Airport and Community Noise Data
TRENT 900 Engines

**ON A/C A380-800 Models A380-800F Models

GROUND IDLE 4 ENGINES RUNNING	MAX THRUST POSSIBLE ON BRAKES 4 ENGINES RUNNING
	

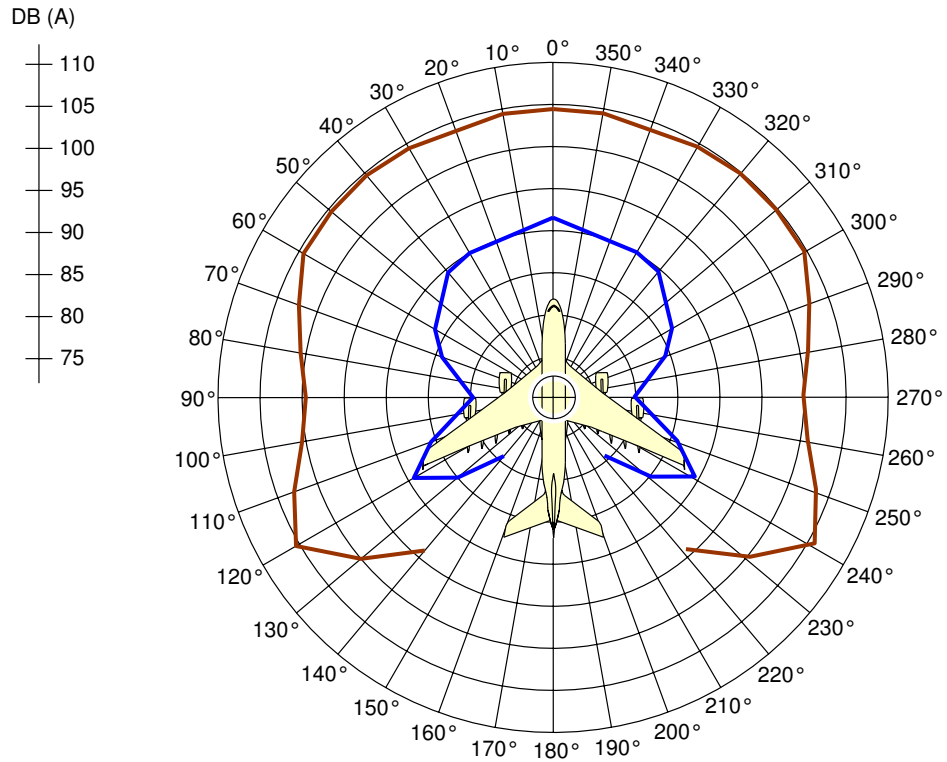

L_AC_060201_1_0010101_01_01

Airport and Community Noise Data
GP 7200 Engines



AIRPLANE CHARACTERISTICS

6-3-0 Danger Areas of the Engines

**ON A/C A380-800 Models A380-800F Models

Danger Areas of the Engines

1. Danger Areas of the Engines



AIRPLANE CHARACTERISTICS

6-3-1 Danger Areas of the Engines - Ground Idle Power



****ON A/C A380-800 Models A380-800F Models**

Danger Areas of the Engines - Ground Idle Power

1. This section gives danger areas of the engines at ground idle power conditions.

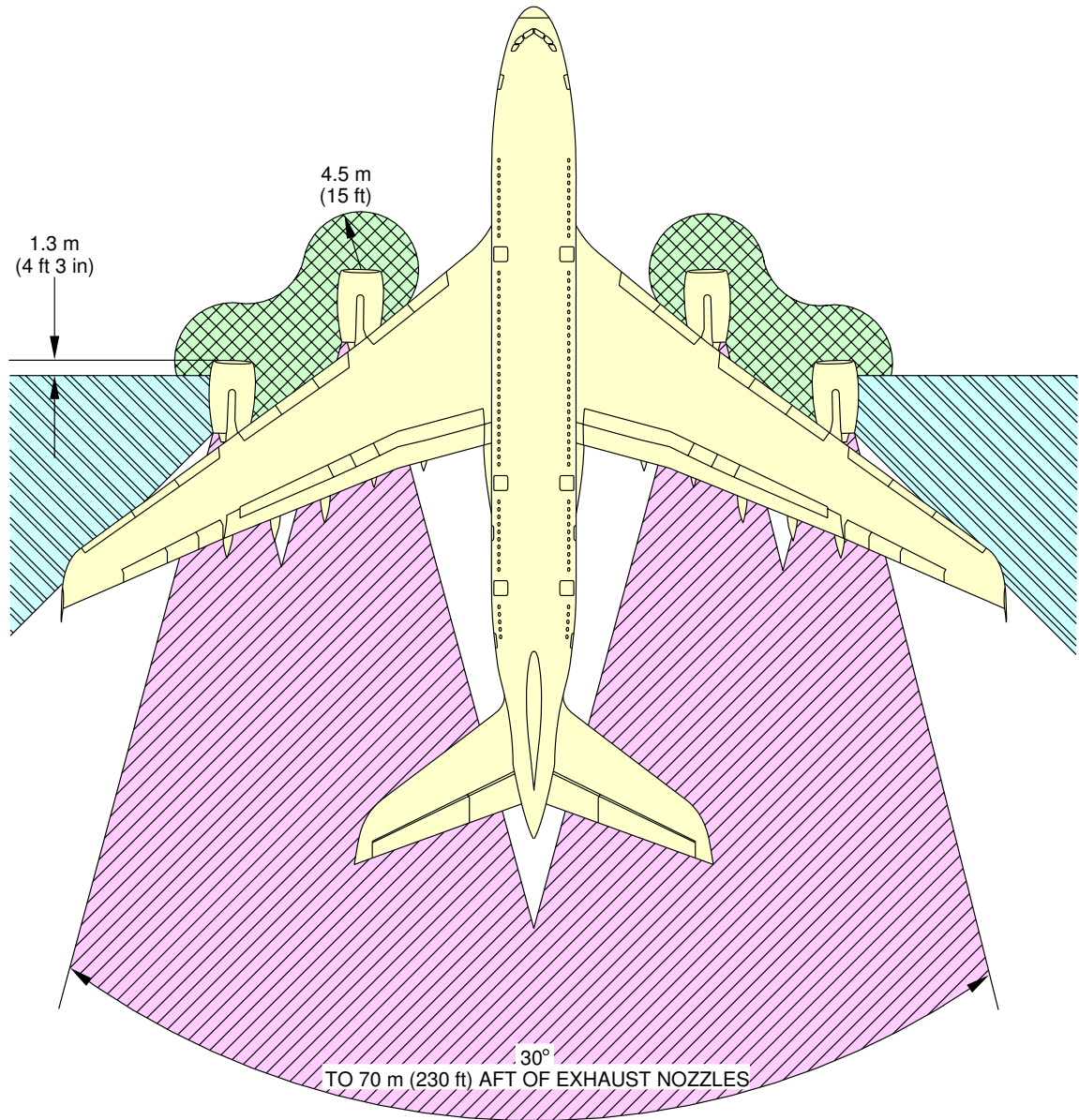
****ON A/C A380-800 Models A380-800F Models**



-  INTAKE SUCTION DANGER AREA MINIMUM IDLE POWER
-  EXHAUST DANGER AREA
-  ENTRY CORRIDOR

deh0001513

L_AC_060301_1_0010101_01_00

Danger Areas of the Engines
Ground Idle Power - TRENT 900 Engines

****ON A/C A380-800 Models A380-800F Models**

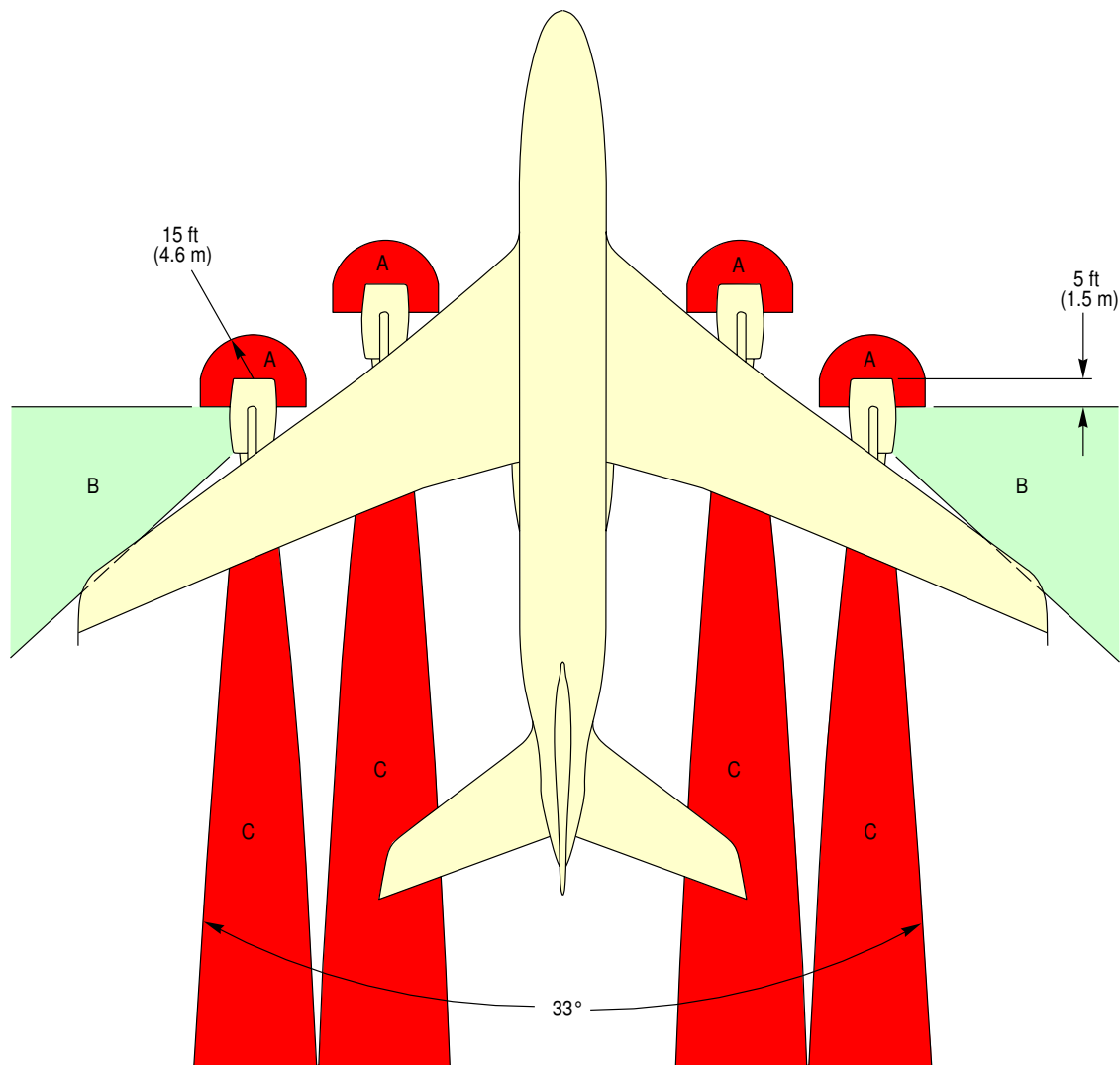

- AREA A - INTAKE SUCTION DANGER AREA
- AREA B - ENTRY CORRIDOR
- AREA C - EXHAUST DANGER AREA (AFT OF EXHAUST NOZZLE)
277 ft (84 m) - GROUND IDLE (20 kt HEADWIND)

E-02197 (0207)
PW V

L_AC_060301_1_0020101_01_01

Danger Areas of the Engines
Ground Idle Power - GP 7200 Engines



AIRPLANE CHARACTERISTICS

6-3-2 Danger Areas of the Engines - Max. Take-Off Power



**ON A/C A380-800 Models A380-800F Models

Danger Areas of the Engines - Max. Take-Off Power

1. This section gives danger areas of the engines at max take-off power conditions.

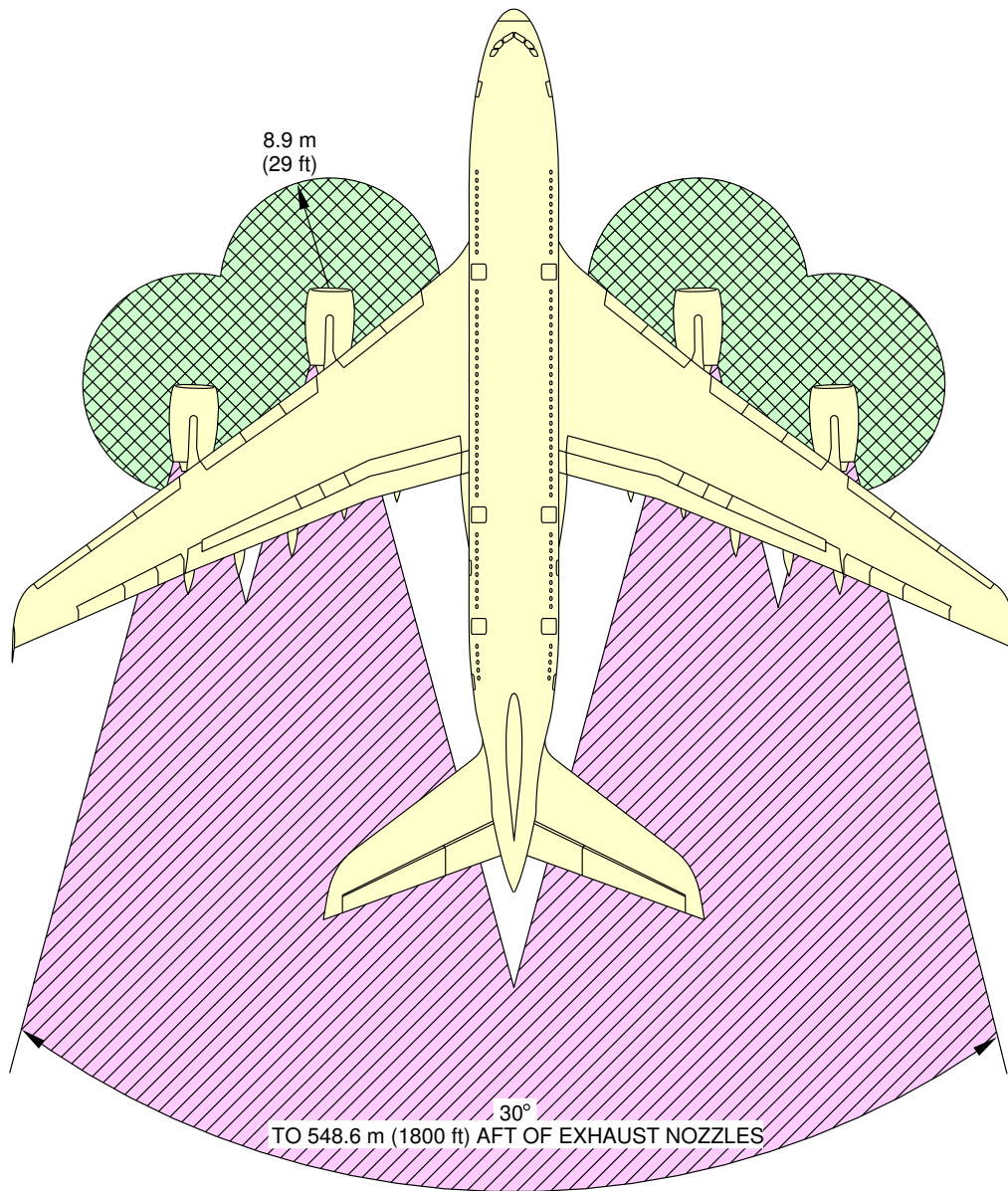
**ON A/C A380-800 Models A380-800F Models



-  INTAKE SUCTION DANGER AREA MAX TAKE-OFF POWER
-  EXHAUST DANGER AREA

deh0001515

L_AC_060302_1_0010101_01_00

Danger Areas of the Engines
Max Take-Off Power - TRENT 900 Engines

****ON A/C A380-800 Models A380-800F Models**

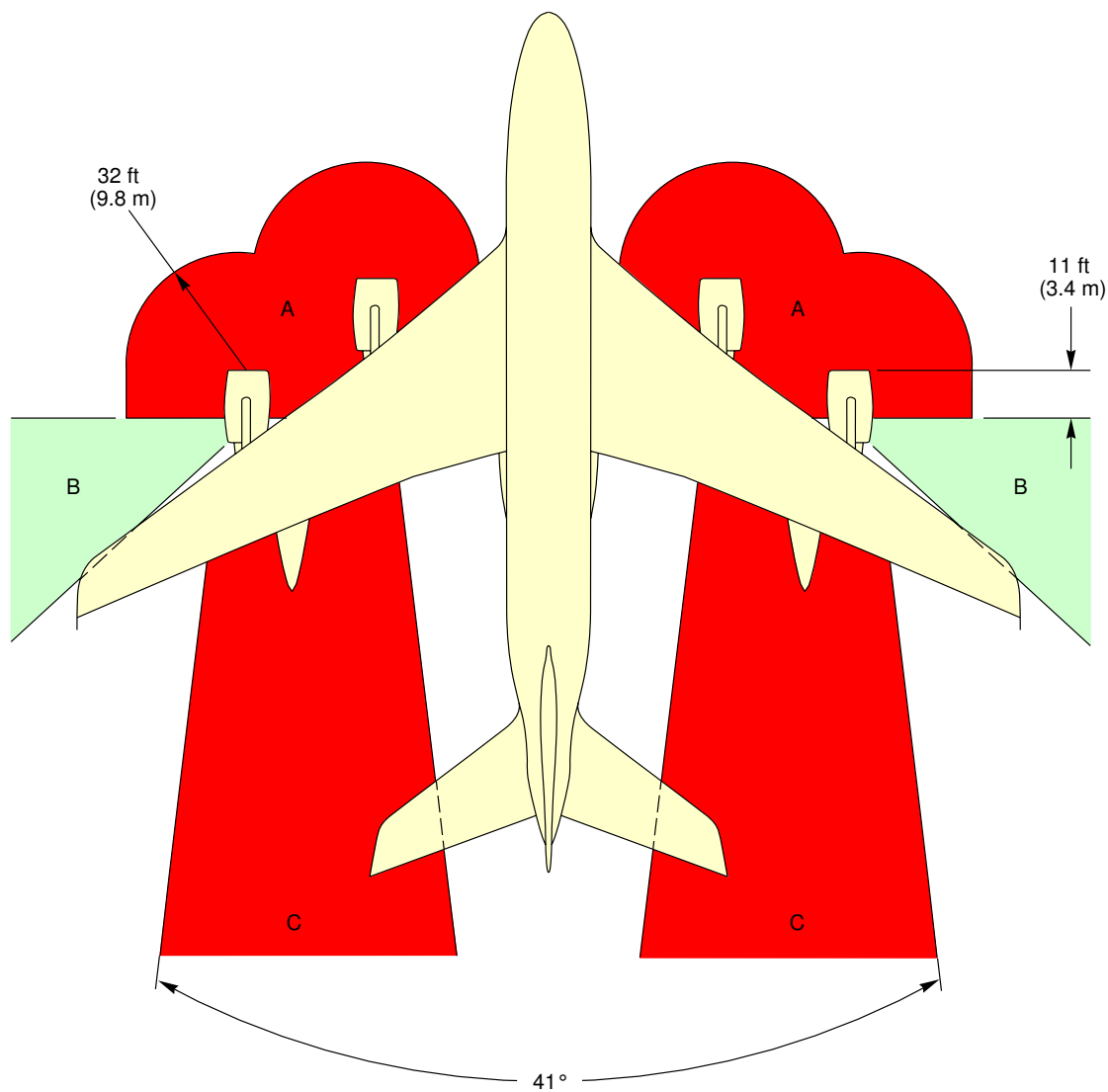

- AREA A – INTAKE SUCTION DANGER AREA
- AREA B – ENTRY CORRIDOR
- AREA C – EXHAUST DANGER AREA (AFT OF EXHAUST NOZZLE)
1553 ft (473 m) – MAXIMUM TAKEOFF (20 kt HEADWIND)

E-02199 (0207)
PW V

L_AC_060302_1_0020101_01_01

Danger Areas of the Engines
Max Take-Off Power - GP 7200 Engines



AIRPLANE CHARACTERISTICS

6-3-3 Danger Areas of the Engines - Breakaway Power



****ON A/C A380-800 Models A380-800F Models**

Danger Areas of the Engines - Breakaway Power

1. This section gives danger areas of the engines at breakaway power.

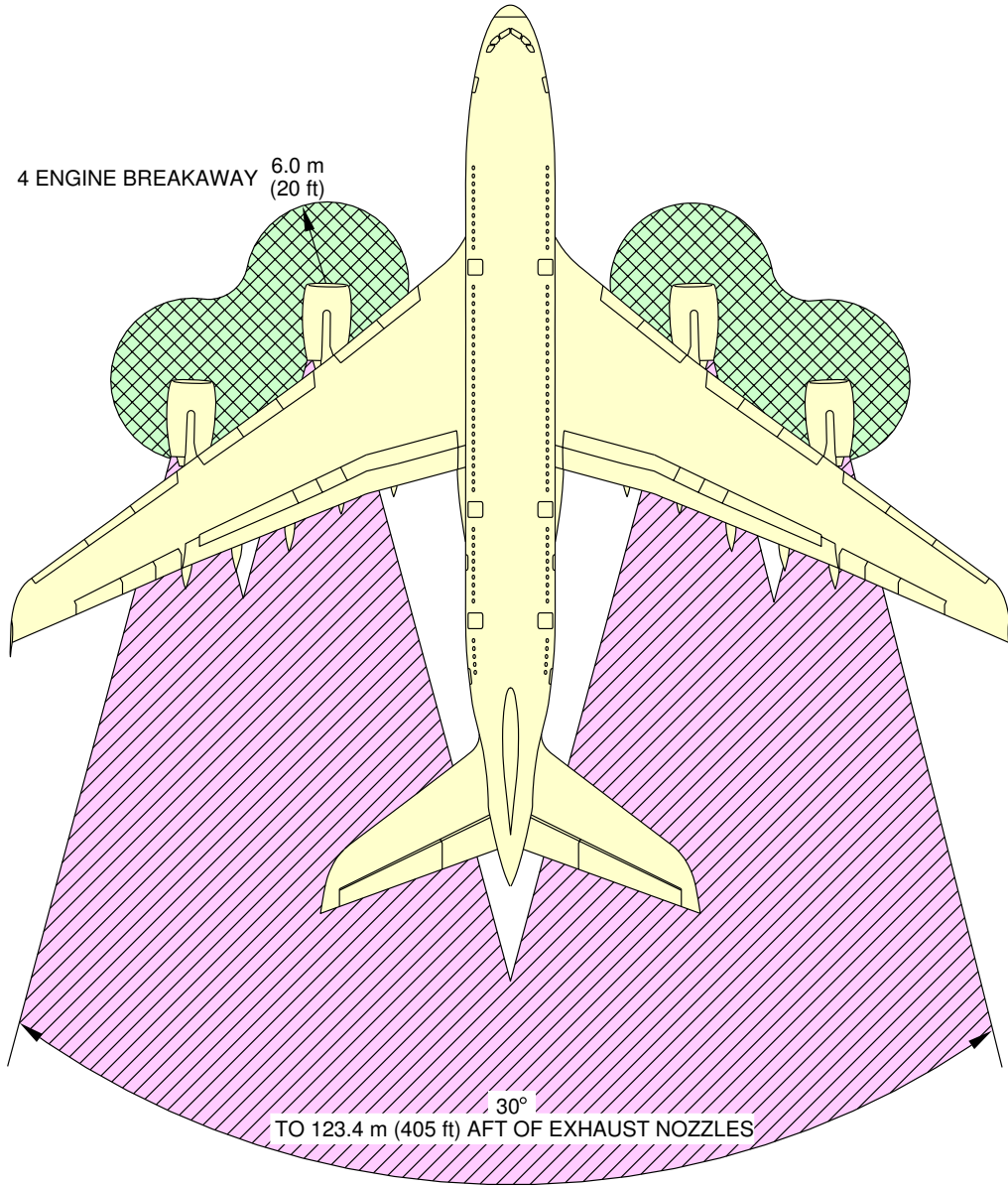
**ON A/C A380-800 Models A380-800F Models



-  INTAKE SUCTION DANGER AREA BREAKAWAY POWER
-  EXHAUST DANGER AREA

deh0001514

L_AC_060303_1_0010101_01_00

Danger Areas of the Engines
Breakaway Power - TRENT 900 Engines

****ON A/C A380-800 Models A380-800F Models**

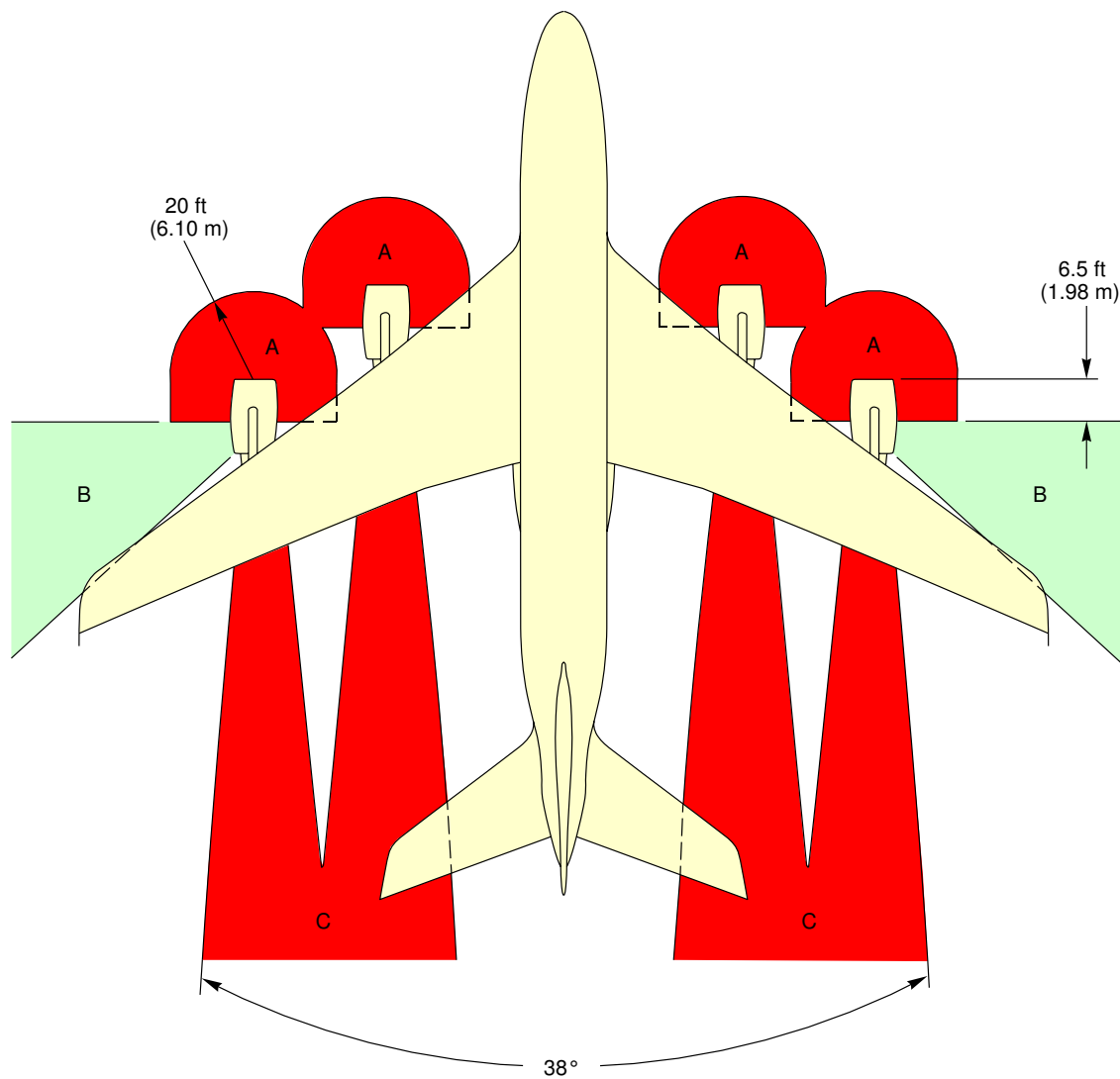

- AREA A – INTAKE SUCTION DANGER AREA
- AREA B – ENTRY CORRIDOR
- AREA C – EXHAUST DANGER AREA (AFT OF EXHAUST NOZZLE)
415 ft (126 m) – BREAKAWAY (20 kt HEADWIND)

E-02198 (0207)
PW V

L_AC_060303_1_0020101_01_01

Danger Areas of the Engines
Breakaway Power - GP 7200 Engines



AIRPLANE CHARACTERISTICS

6-4-0 APU Exhaust Velocities and Temperatures

****ON A/C A380-800 Models A380-800F Models**

APU Exhaust Velocities and Temperatures

1. APU Exhaust Velocities and Temperatures



AIRPLANE CHARACTERISTICS

6-4-1 APU Exhaust Velocities and Temperatures

****ON A/C A380-800 Models A380-800F Models**

APU Exhaust Velocities and Temperatures

1. This section gives APU exhaust velocities and temperatures in max. ECS conditions.

****ON A/C A380-800 Models A380-800F Models**

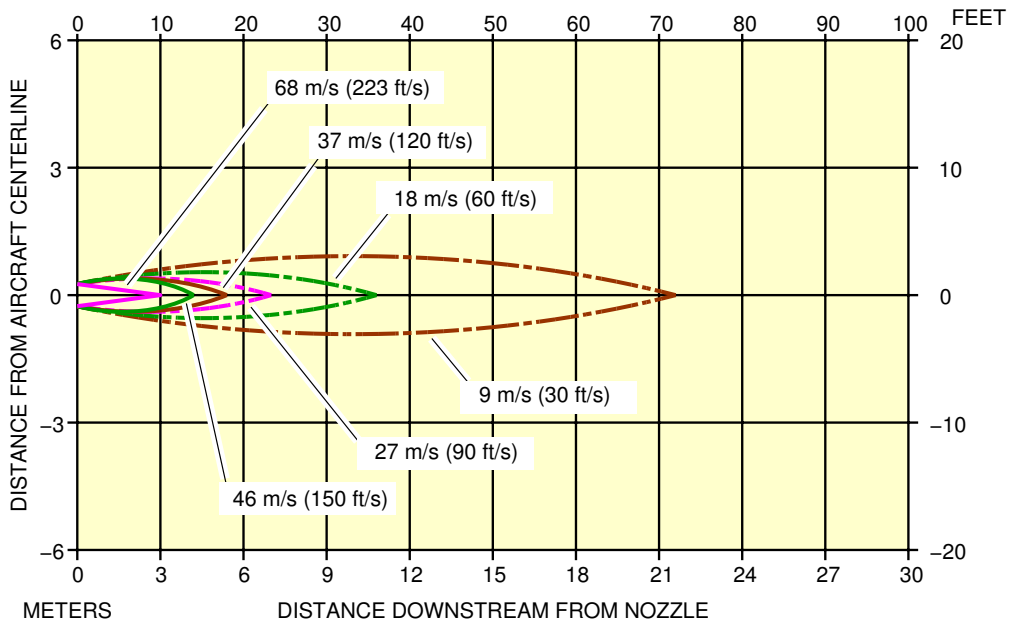
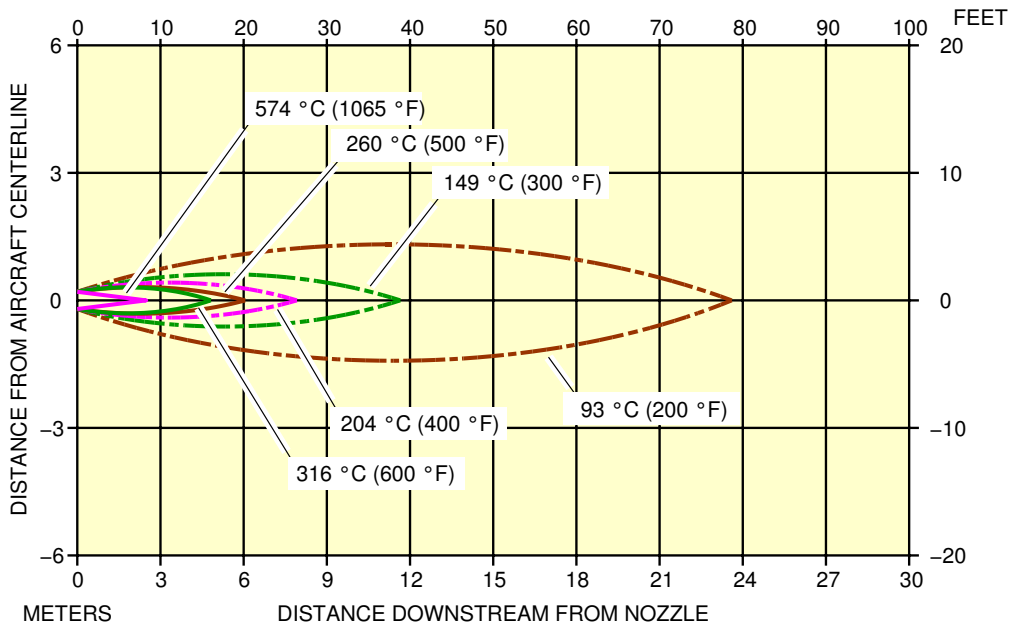

NOTE: THE DATA GIVEN IS BASED ON THE FOLLOWING ASSUMPTIONS:

- SEA LEVEL STATIC CONDITIONS
- ISA + 23 °C (73 °F)
- NO WIND

L_AC_060401_1_0010101_01_00

APU Exhaust Velocities and Temperatures
Max. ECS Conditions



AIRPLANE CHARACTERISTICS

6-4-2 APU Exhaust Velocities and Temperatures - MES Conditions

**ON A/C A380-800 Models A380-800F Models

APU Exhaust Velocities and Temperatures - MES Conditions

1. This section gives the APU exhaust velocities and temperatures in MES conditions.

****ON A/C A380-800 Models A380-800F Models**

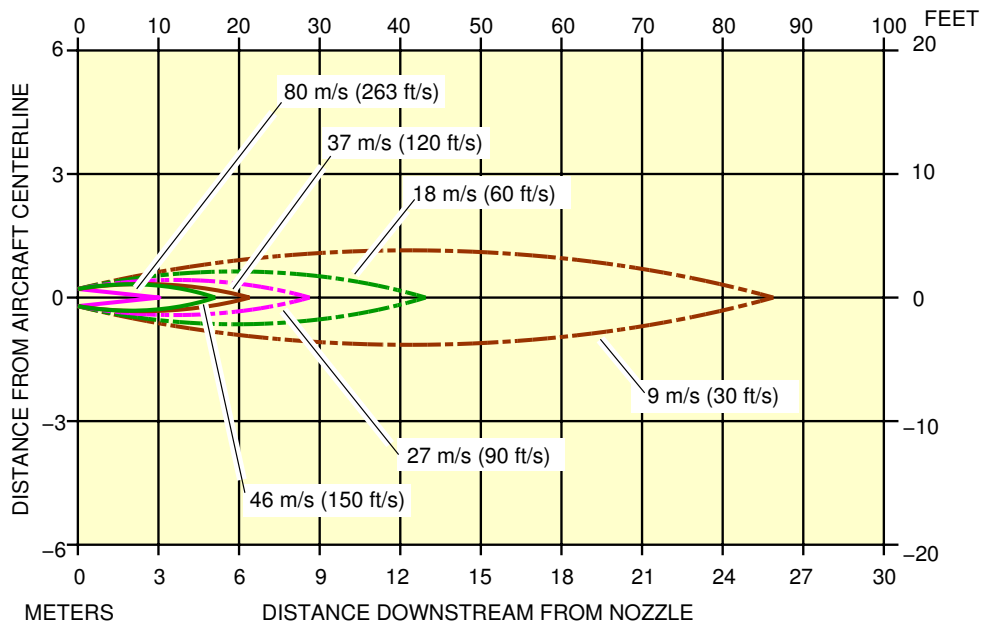
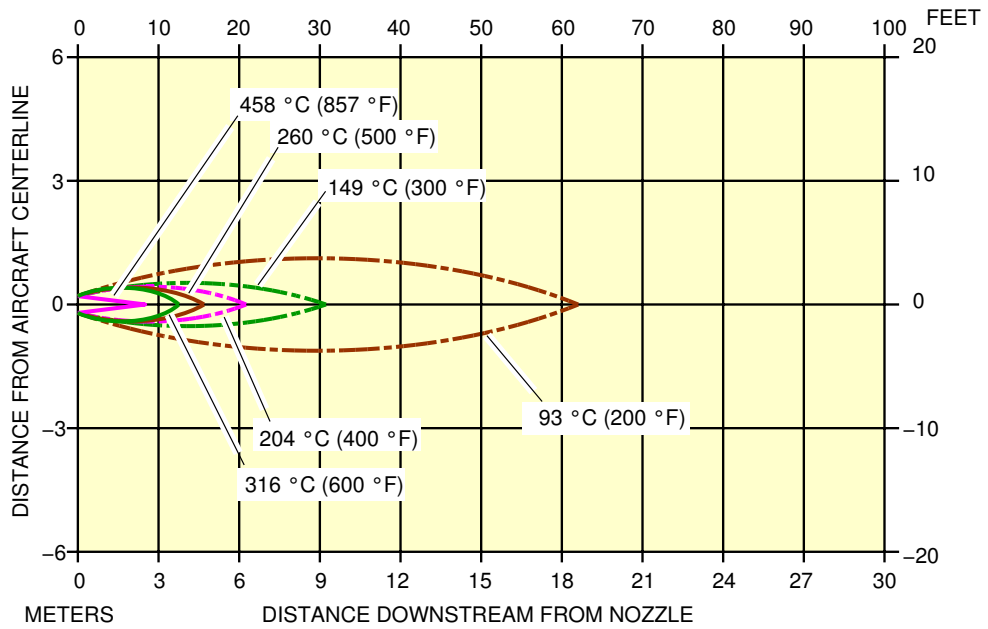

NOTE: THE DATA GIVEN IS BASED ON THE FOLLOWING ASSUMPTIONS:

- SEA LEVEL STATIC CONDITIONS
- ISA + 23 °C (73 °F)
- NO WIND

L_AC_060402_1_0010101_01_00

APU Exhaust Velocities and Temperatures
MES Conditions

PAVEMENT DATA

7-1-0 General Information

****ON A/C A380-800 Models A380-800F Models**

General Information

1. A brief description of the pavement charts that follow will help in airport planning.

To help in the interpolation between the discrete values shown, each airplane configuration is shown with a minimum range of five loads on the main landing gear.

All curves on the charts represent data at a constant specified tire pressure with:

- the airplane loaded to the maximum ramp weight
- the CG at its maximum permissible aft position.

Pavement requirements for commercial airplanes are derived from the static analysis of loads imposed on the main landing gear struts.

Section 7-2-0, gives basic data on the landing gear footprint configuration, maximum ramp weights and tire sizes and pressures configuration.

Section 7-3-0, shows maximum vertical and horizontal pavement loads for certain critical conditions at the tire-ground interfaces.

Section 7-4-0 contains charts to find these loads throughout the stability limit of the airplane at rest on the pavement.

Section 7-4-2 gives examples of the distribution of the main landing load to the wing and body landing gears.

Section 7-4-3 shows the distribution of the main landing gear load to the wing and body gears.

These main landing gear loads are used as the point of entry to the pavement design charts which follow, interpolating load values where necessary.

Section 7-5-1 uses procedures in Instruction Report No. S-77-1 "Procedures for Development of CBR Design Curves", dated June 1977 to show flexible pavement design curves.

The report was prepared by the U.S. Army Corps Engineer Waterways Experiment Station, Soil and Pavement Laboratory, Vicksburg, Mississippi.

The line showing 10 000 coverages is used to calculate the Aircraft Classification Number (ACN).

The procedure that follows is used to develop flexible pavement design curves such as those shown in Section 7-5-1.

- A. With the scale for pavement thickness at the bottom and the scale for CBR at the top, an arbitrary load line is drawn representing 10 000 coverages.
- B. Incremental values of the weight on the main landing gear are then plotted.
- C. Annual departure lines are drawn based on the load lines of the weight on the main landing gear that is shown on the graph.

Section 7-7-1 gives the rigid pavement design curves that have been prepared with the use of the Westergaard Equation. This is in general accordance with the procedures outlined in the Portland Cement Association publications, "Design of Concrete Airport Pavement", 1973 and "Computer Program for Airport Pavement Design", (Program PDILB), 1967 both by Robert G. Packard.

2. The procedure that follows is used to develop rigid pavement design curves such as those shown in Section 7-7-1
 - A. With the scale for pavement thickness on the left and the scale for allowable working stress on the right, an arbitrary line load line is drawn. This represents the main landing gear maximum weight to be shown.
 - B. All values of the subgrade modulus (k values) are then plotted.
 - C. Additional load lines for the incremental values of weight on the main landing gear are drawn on the basis of the curve for $k = 80 \text{ MN/m}^3$ already shown on the graph.

All Load Classification Number (LCN) curves shown in Section 7-6-1 and Section 7-8-2 have been developed from a computer program based on data provided in the International Civil Aviation Organisation (ICAO) document 7920-AN/865/2, Aerodrome Manual, Part 2, "Aerodrome Physical Characteristics", Second Edition, 1965.

The flexible pavement charts in Section 7-6-1 show LCN against equivalent single wheel load, and equivalent single wheel load against pavement thickness.

The rigid pavement charts in Section 7-8-2 show LCN against equivalent single wheel load against radius of relative stiffness.

Section 7-9-0 provides ACN data prepared according to the ACN/PCN system as referenced in ICAO Annex 14, "Aerodromes", Volume 1 "Aerodrome Design and Operations" Fourth Edition July 2004, incorporating Amendments 1 to 6.

The ACN/PCN system provides a standardized international airplane/pavement rating system replacing the various S, T, TT, LCN, AUW, ISWL, etc., rating systems used throughout the world.

ACN is the Aircraft Classification Number and PCN is the corresponding Pavement Classification Number.

An aircraft having an ACN equal to or less than the PCN can operate without restriction on the pavement.

Numerically the ACN is two times the derived single wheel load (expressed in thousands of kilograms).

The derived single wheel load is defined as the load on a single tire inflated to 1.25 MPa (181 psi) that would have the same pavement requirements as the aircraft.

Computationally, the ACN/PCN system uses PCA program PDILB for rigid pavement and S-77-1 for flexible pavements to calculate ACN values.

The Airport Authority must decide on the method of pavement analysis and the results of their evaluation shown as follows:

PCN			
PAVEMENT TYPE	SUBGRADE CATEGORY	TIRE-PRESSURE CATEGORY	EVALUATION METHOD
R - Rigid	A - HighLow	W - No Limit	T - Technical
F - Flexible	B - Medium	X - To 1.5 MPa (217 psi)	U - Using aircraft
	C - Low	Y - To 1 MPa (145 psi)	
	D - Ultra Low	Z - To 0.5 MPa (73 psi)	

Section 7-9-1 show the aircraft ACN values for flexible pavements. The four subgrade categories are :

- A High Strength CBR 15
- B Medium Strength CBR 10
- C Low Strength CBR 6
- D Ultra Low Strength CBR 3

Section 7-9-2 show the aircraft ACN for rigid pavements.

The four subgrade categories are :

- A High Strength Subgrade $k = 150 \text{ MN/m}^3$ (550 pci)
- B Medium Strength Subgrade $k = 80 \text{ MN/m}^3$ (300 pci)
- C Low Strength Subgrade $k = 40 \text{ MN/m}^3$ (150 pci)
- D Ultra Low Strength Subgrade $k = 20 \text{ MN/m}^3$ (75 pci)



AIRPLANE CHARACTERISTICS

7-2-0 Landing Gear Footprint

****ON A/C A380-800 Models**

Landing Gear Footprint - Pax

1. This section gives the Landing Gear Footprint.

****ON A/C A380-800 Models**

MAXIMUM RAMP WEIGHT	512 000 kg (1 128 775 lb)
PERCENTAGE OF WEIGHT ON MAIN GEAR GROUP	See Section 7-4-1 Figure: Landing Gear Loading on Pavement – MRW 512 000 kg – A380-800 Models
NOSE GEAR TIRE SIZE	1270 x 455R22 32PR or 50 x 20R22 34PR
NOSE GEAR TIRE PRESSURE	14.1 bar (205 psi)
WING GEAR TIRE SIZE	1400 x 530R23 40PR
WING GEAR TIRE PRESSURE	14 bar (203 psi)
BODY GEAR TIRE SIZE	1400 x 530R23 40PR
BODY GEAR TIRE PRESSURE	14 bar (203 psi)

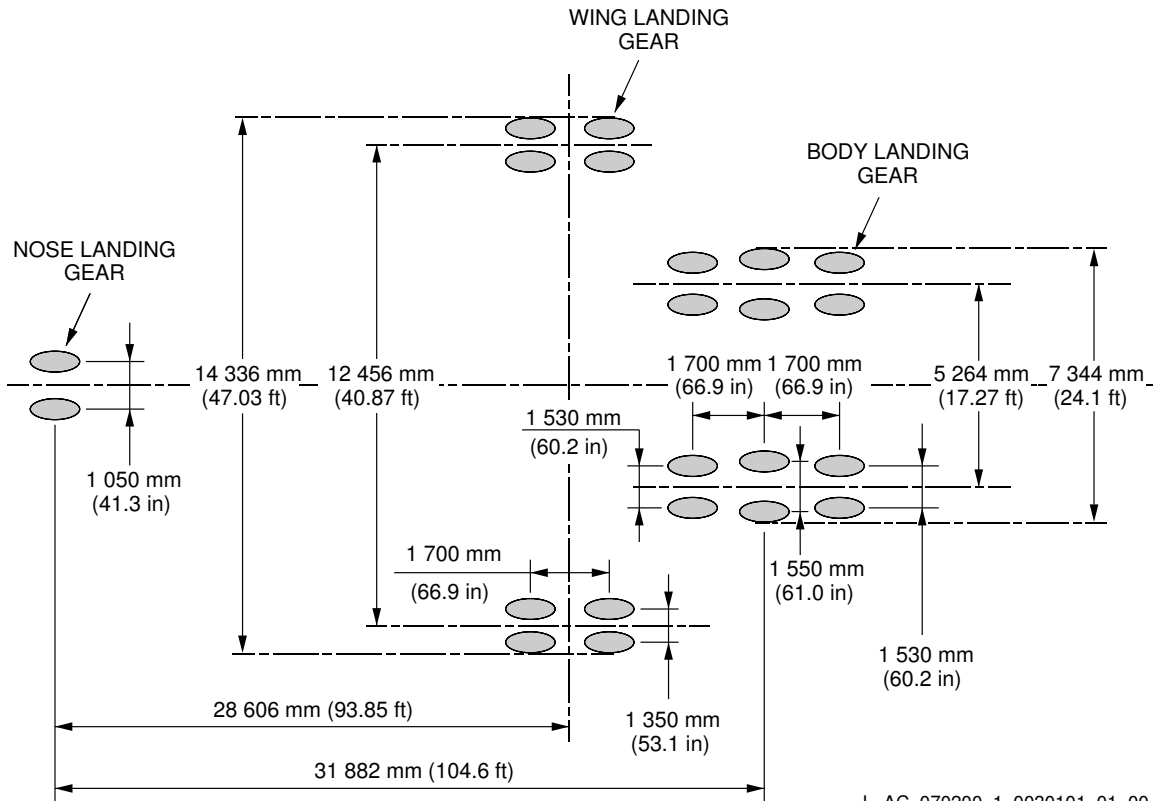

Landing Gear Footprint
MRW 512 000 kg - A380-800 Models

****ON A/C A380-800 Models**

MAXIMUM RAMP WEIGHT	562 000 kg (1 239 000 lb)
PERCENTAGE OF WEIGHT ON MAIN GEAR GROUP	See Section 7-4-1 Figure: Landing Gear Loading on Pavement – MRW 562 000 kg – A380-800 Models
NOSE GEAR TIRE SIZE	1270 x 455R22 32PR or 50 x 20R22 34PR
NOSE GEAR TIRE PRESSURE	14.1 bar (205 psi)
WING GEAR TIRE SIZE	1400 x 530R23 40PR
WING GEAR TIRE PRESSURE	15 bar (218 psi)
BODY GEAR TIRE SIZE	1400 x 530R23 40PR
BODY GEAR TIRE PRESSURE	15 bar (218 psi)

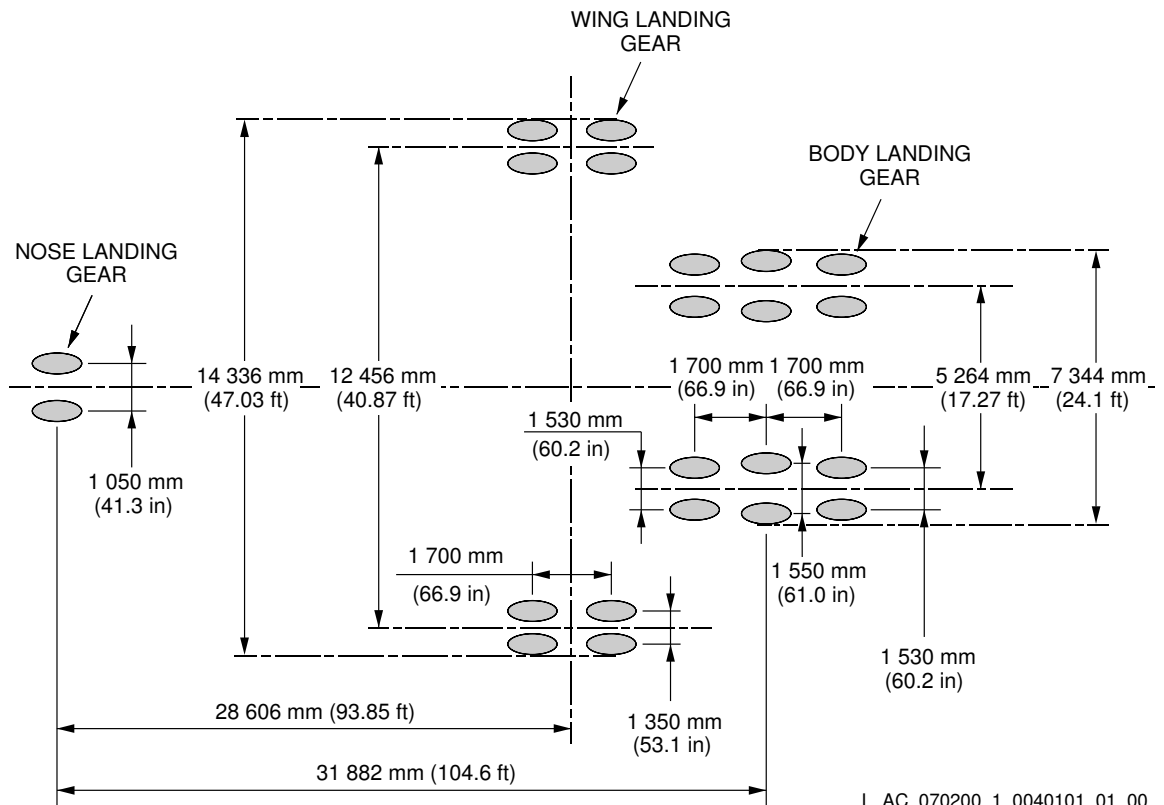

Landing Gear Footprint
MRW 562 000 kg - A380-800 Models

****ON A/C A380-800 Models**

MAXIMUM RAMP WEIGHT	571 000 kg (1 258 850 lb)
PERCENTAGE OF WEIGHT ON MAIN GEAR GROUP	See Section 7-4-1 Figure: Landing Gear Loading on Pavement – MRW 571 000 kg – A380-800 Models
NOSE GEAR TIRE SIZE	1270 x 455R22 32PR or 50 x 20R22 34PR
NOSE GEAR TIRE PRESSURE	14.1 bar (205 psi)
WING GEAR TIRE SIZE	1400 x 530R23 40PR
WING GEAR TIRE PRESSURE	15 bar (218 psi)
BODY GEAR TIRE SIZE	1400 x 530R23 40PR
BODY GEAR TIRE PRESSURE	15 bar (218 psi)

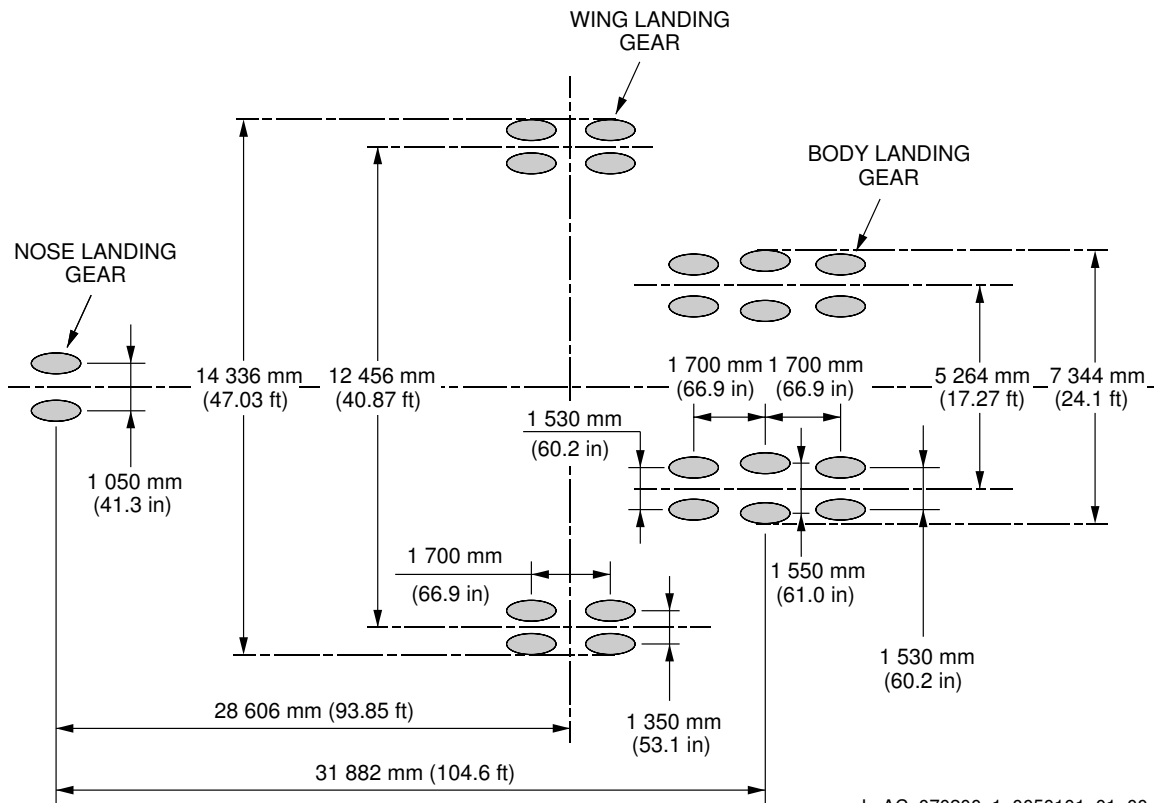

L_AC_070200_1_0050101_01_00

Landing Gear Footprint
MRW 571 000 kg - A380-800 Models



AIRPLANE CHARACTERISTICS

****ON A/C A380-800F Models**

Landing Gear Footprint - Freighter

1. This section gives the Landing Gear Footprint.

****ON A/C A380-800F Models**

MAXIMUM RAMP WEIGHT	592 000 kg (1 305 125 lb)
PERCENTAGE OF WEIGHT ON MAIN GEAR GROUP	See Section 7-4-1 Figure: Landing Gear Loading on Pavement – MRW 592 000 kg – A380-800F Models
NOSE GEAR TIRE SIZE	50 x 20R22 34PR
NOSE GEAR TIRE PRESSURE	14.9 bar (216 psi)
WING GEAR TIRE SIZE	1400 x 530R23 42PR
WING GEAR TIRE PRESSURE	16.1 bar (234 psi)
BODY GEAR TIRE SIZE	1400 x 530R23 42PR
BODY GEAR TIRE PRESSURE	16.1 bar (234 psi)

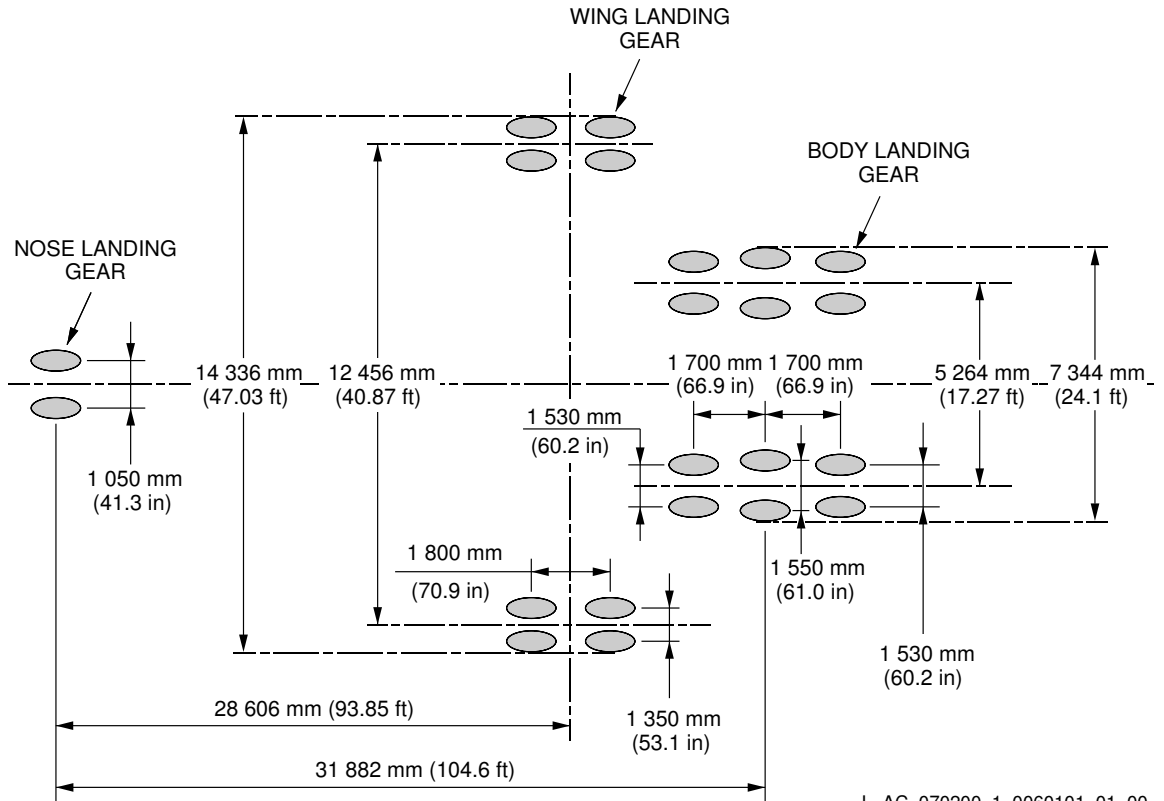

****ON A/C A380-800F Models**

MAXIMUM RAMP WEIGHT	602 000 kg (1 327 175 lb)
PERCENTAGE OF WEIGHT ON MAIN GEAR GROUP	See Section 7-4-1 Figure: Landing Gear Loading on Pavement – MRW 602 000 kg – A380-800F Models
NOSE GEAR TIRE SIZE	50 x 20R22 34PR
NOSE GEAR TIRE PRESSURE	14.9 bar (216 psi)
WING GEAR TIRE SIZE	1400 x 530R23 42PR
WING GEAR TIRE PRESSURE	16.1 bar (234 psi)
BODY GEAR TIRE SIZE	1400 x 530R23 42PR
BODY GEAR TIRE PRESSURE	16.1 bar (234 psi)

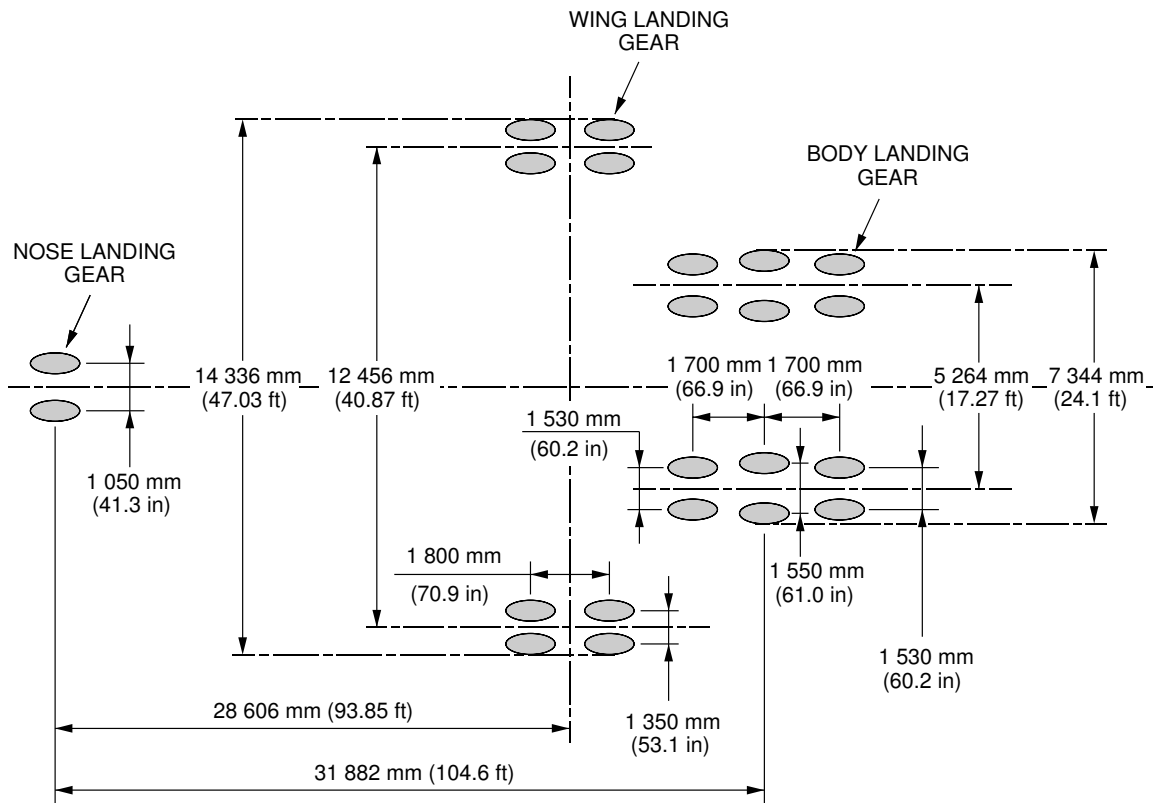

L_AC_070200_1_0070101_01_00

Landing Gear Footprint
MRW 602 000 kg - A380-800F Models



AIRPLANE CHARACTERISTICS

7-3-0 Maximum Pavement Loads

****ON A/C A380-800 Models**

Maximum Pavement Loads - Pax

1. This section gives Maximum Pavement Loads.

**ON A/C A380-800 Models

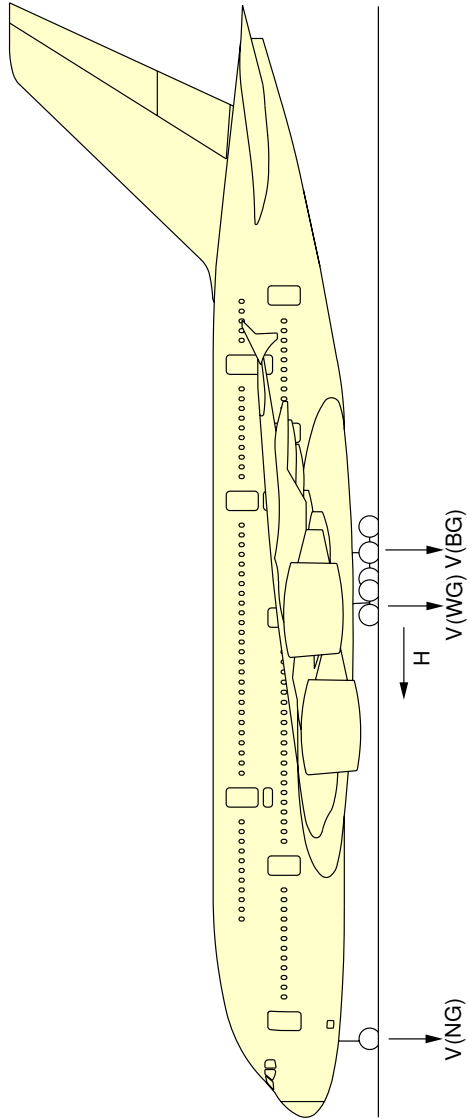

1	2		3		4		5		6		7			
	MAXIMUM RAMP WEIGHT		STATIC LOAD AT MOST FWD CG (1)		VNG		VWG (PER STRUT)		VBG (PER STUT)		H (PER STRUT)			
MODEL	lb	kg	lb	kg	lb	kg	lb	kg	lb	kg	lb	kg		
-800	1 128 775	512 000	87 700	39 770	147 425	66 880	214 750	97 410	322 125	146 110	70 175(3)	31 830(3)	171 800(3)	77 930(3)
											105 250(4)	47 740(4)	257 700(4)	116 890(4)

V (NG) MAXIMUM VERTICAL NOSE GEAR GROUND LOAD AT MOST FORWARD CG

V (WG) MAXIMUM VERTICAL WING GEAR GROUND LOAD AT MOST AFT CG

V (BG) MAXIMUM VERTICAL BODY GEAR GROUND LOAD AT MOST AFT CG

H MAXIMUM HORIZONTAL GROUND LOAD FROM BRAKING

(1) FWD CG = 35.81 % MAC

(2) AFT CG = 43 % MAC

(3) BRAKED WING GEAR

(4) BRAKED BODY GEAR

NOTE: ALL LOADS CALCULATED USING AIRPLANE MAXIMUM RAMP WEIGHT

L_AC_070300_1_0050101_01_00

Maximum Pavement Loads
MRW 512 000 kg - A380-800 Models

**ON A/C A380-800 Models

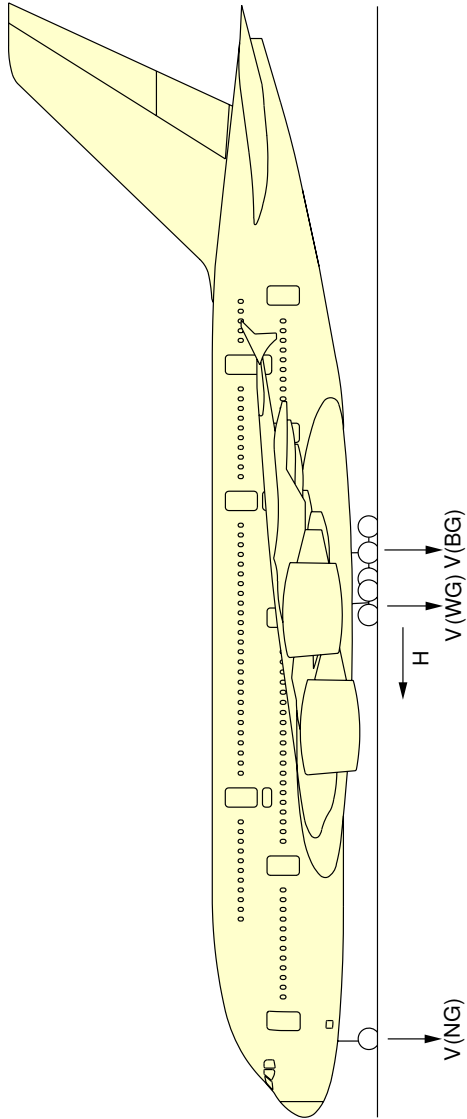

1	MODEL	2		3		4		5		6		7			
		lb	kg	lb	kg	lb	kg	lb	kg	lb	kg	lb	kg		
-800		1 239 000	562 000	87 825	39 840	153 400	69 590	235 725	106 920	353 575	160 380	77 025(3)	34 940(3)	188 575(3)	85 540(3)
												115 525(4)	52 400(4)	282 850(4)	128 300(4)

V(NG) MAXIMUM VERTICAL NOSE GEAR GROUND LOAD AT MOST FORWARD CG

V(WG) MAXIMUM VERTICAL WING GEAR GROUND LOAD AT MOST AFT CG

V(BG) MAXIMUM VERTICAL BODY GEAR GROUND LOAD AT MOST AFT CG

H MAXIMUM HORIZONTAL GROUND LOAD FROM BRAKING

(1) FWD CG = 37.5 % MAC

(2) AFT CG = 43.0 % MAC

(3) BRAKED WING GEAR

(4) BRAKED BODY GEAR

NOTE: ALL LOADS CALCULATED USING AIRPLANE MAXIMUM RAMP WEIGHT

L_AC_070300_1_0010101_01_01

Maximum Pavement Loads
MRW 562 000 kg - A380-800 Models

**ON A/C A380-800 Models

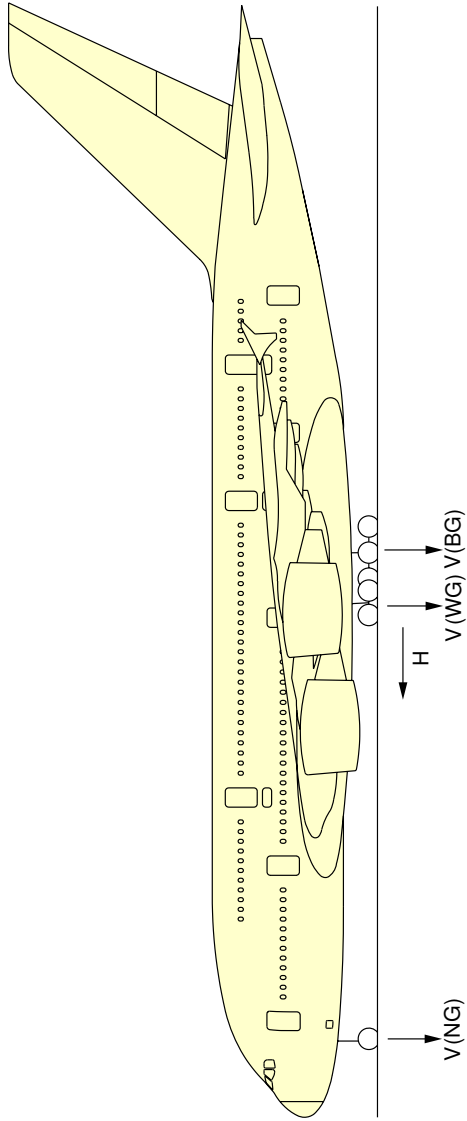

1	MODEL	2		3		4		5		6		7			
		MAXIMUM RAMP WEIGHT		STATIC LOAD AT MOST FWD CG (1)		STATIC BRAKING @ 10 ft/s ² DECELERATION		STATIC LOAD AT MAX AFT CG (2)		STATIC LOAD AT MAX AFT CG (2)		STATIC BRAKING @ 10 ft/s ² DECELERATION			
		lb	kg	lb	kg	lb	kg	lb	kg	lb	kg	lb	kg		
-800		1 258 850	571 000	87 725	39 790	154 350	70 010	237 475	107 710	356 200	161 570	78 250(3)	35 490(3)	189 975(3)	86 170(3)
												117 375(4)	53 240(4)	284 950(4)	129 260(4)

V(NG) MAXIMUM VERTICAL NOSE GEAR GROUND LOAD AT MOST FORWARD CG
V(WG) MAXIMUM VERTICAL WING GEAR GROUND LOAD AT MOST AFT CG
V(BG) MAXIMUM VERTICAL BODY GEAR GROUND LOAD AT MOST AFT CG
H MAXIMUM HORIZONTAL GROUND LOAD FROM BRAKING
(1) FWD CG = 37.8 % MAC
(2) AFT CG = 41.0 % MAC
(3) BRAKED WING GEAR
(4) BRAKED BODY GEAR

NOTE: ALL LOADS CALCULATED USING AIRPLANE MAXIMUM RAMP WEIGHT

L_AC_070300_1_0030101_01_00

Maximum Pavement Loads
MRW 571 000 kg - A380-800 Models



AIRPLANE CHARACTERISTICS

****ON A/C A380-800F Models**

Maximum Pavement Loads - Freighter

1. This section gives Maximum Pavement Loads.

**ON A/C A380-800F Models

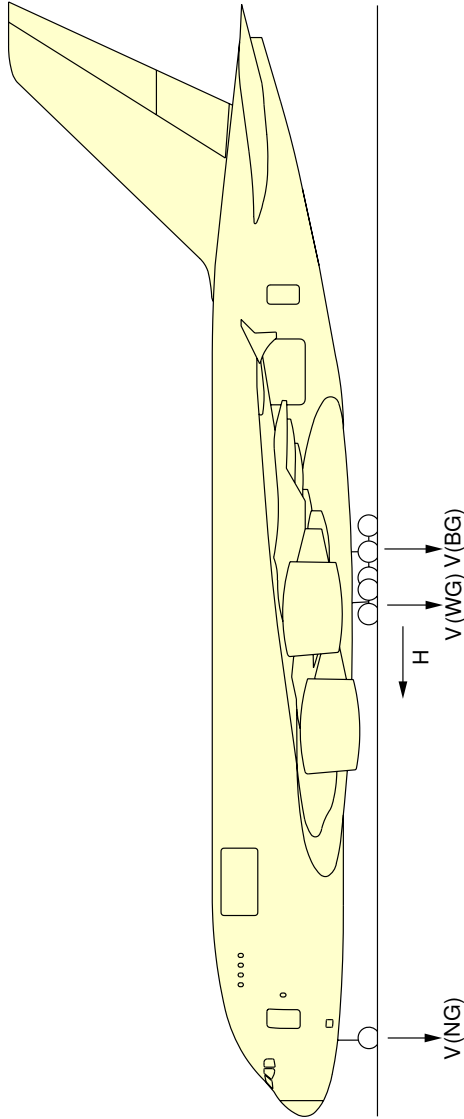

1	MODEL	2		3		4		5		6		7			
		lb	kg	lb	kg	lb	kg	lb	kg	lb	kg	lb	kg		
-800F		1 305 125	592 000	100 400	45 540	169 475	76 870	248 100	112 530	372 125	168 800	81 125(3)	36 800(3)	198 475(3)	90 030(3)
												121 700(4)	55 200(4)	297 700(4)	135 040(4)

V(NG) MAXIMUM VERTICAL NOSE GEAR GROUND LOAD AT MOST FORWARD CG
V(WG) MAXIMUM VERTICAL WING GEAR GROUND LOAD AT MOST AFT CG
V(BG) MAXIMUM VERTICAL BODY GEAR GROUND LOAD AT MOST AFT CG
H MAXIMUM HORIZONTAL GROUND LOAD FROM BRAKING
(1) FWD CG = 36.0 % MAC
(2) AFT CG = 42.8 % MAC
(3) BRAKED WING GEAR
(4) BRAKED BODY GEAR

NOTE: ALL LOADS CALCULATED USING AIRPLANE MAXIMUM RAMP WEIGHT

L_AC_070300_1_0020101_01_01

Maximum Pavement Loads - Freighter
MRW 592 000 kg - A380-800F Models

**ON A/C A380-800F Models

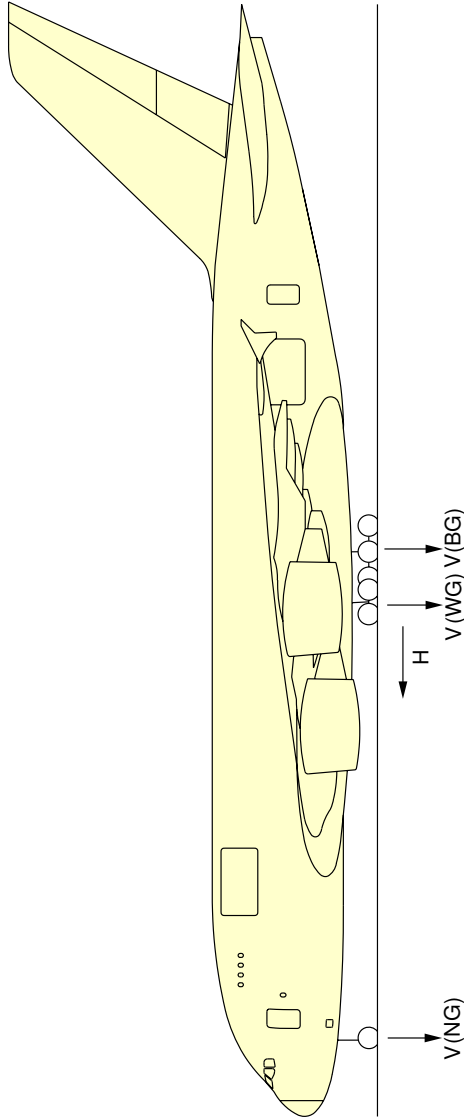

1	MODEL	2		3		4		5		6		7							
		MAXIMUM RAMP WEIGHT		STATIC LOAD AT MOST FWD CG (1)		VNG		VWG (PER STRUT)		VBG (PER STUT)		H (PER STRUT)							
		lb	kg	lb	kg	lb	kg	lb	kg	lb	kg	lb	kg						
-800F		1 327 175	602 000	100 475	45 580	170 725	77 440	252 175	114 380	378 250	171 580	82 500(3)	37 420(3)	201 750(3)	91 510(3)	123 750(4)	56 130(4)	302 600(4)	137 260(4)

V(NG) MAXIMUM VERTICAL NOSE GEAR GROUND LOAD AT MOST FORWARD CG

V(WG) MAXIMUM VERTICAL WING GEAR GROUND LOAD AT MOST AFT CG

V(BG) MAXIMUM VERTICAL BODY GEAR GROUND LOAD AT MOST AFT CG

H MAXIMUM HORIZONTAL GROUND LOAD FROM BRAKING

(1) FWD CG = 36.3 % MAC

(2) AFT CG = 42.7 % MAC

(3) BRAKED WING GEAR

(4) BRAKED BODY GEAR

NOTE: ALL LOADS CALCULATED USING AIRPLANE MAXIMUM RAMP WEIGHT

L_AC_070300_1_0040101_01_00

Maximum Pavement Loads
MRW 602 000 kg- A380-800F Models

7-4-0 Landing Gear Loading on Pavement

**ON A/C A380-800 Models A380-800F Models

Landing Gear Loading on Pavement

1. General

The Main Landing Gear Group consists of two Wing Gears (4 Wheel Bogies) plus two Body Gears (6 Wheel Bogies).

- A380-800 models :

In the example shown in Section 7-4-1 with MRW 512000 kg, the Gross Aircraft Weight is 450000 kg (992080 lb) and the percentage of weight on the Main Landing gear is 95.1 %. For these conditions the total weight on the Main Landing Gear Group is 428000 kg (943580 lb).

In the example shown in Section 7-4-1 with MRW 562000 kg, the Gross Aircraft Weight is 450000 kg (992080 lb) and the percentage of weight on the Main Landing gear is 95.1 %. For these conditions the total weight on the Main Landing Gear Group is 428000 kg (943580 lb).

In the example shown in Section 7-4-1 with MRW 571000 kg, the Gross Aircraft Weight is 450000 kg (992080 lb) and the percentage of weight on the Main Landing gear is 94.3 %. For these conditions the total weight on the Main Landing Gear Group is 424400 kg (935040 lb).

- A380-800F models :

In the example shown in Section 7-4-1 with MRW 592000 kg, the Gross Aircraft Weight is 450000 kg (992080 lb) and the percentage of weight on the Main Landing gear is 95.04 %. For these conditions the total weight on the MLG Group is 427700 (942920 lb).

In the example shown in Section 7-4-1 with MRW 602000 kg, the Gross Aircraft Weight is 450000 kg (992080 lb) and the percentage of weight on the Main Landing gear is 95 %. For these conditions the total weight on the MLG Group is 427500 (942475 lb).



AIRPLANE CHARACTERISTICS

7-4-1 Landing Gear Loading on Pavement

****ON A/C A380-800 Models**

Landing Gear Loading on Pavement - Pax

1. This section gives Landing Gear Loading on Pavement.

**ON A/C A380-800 Models

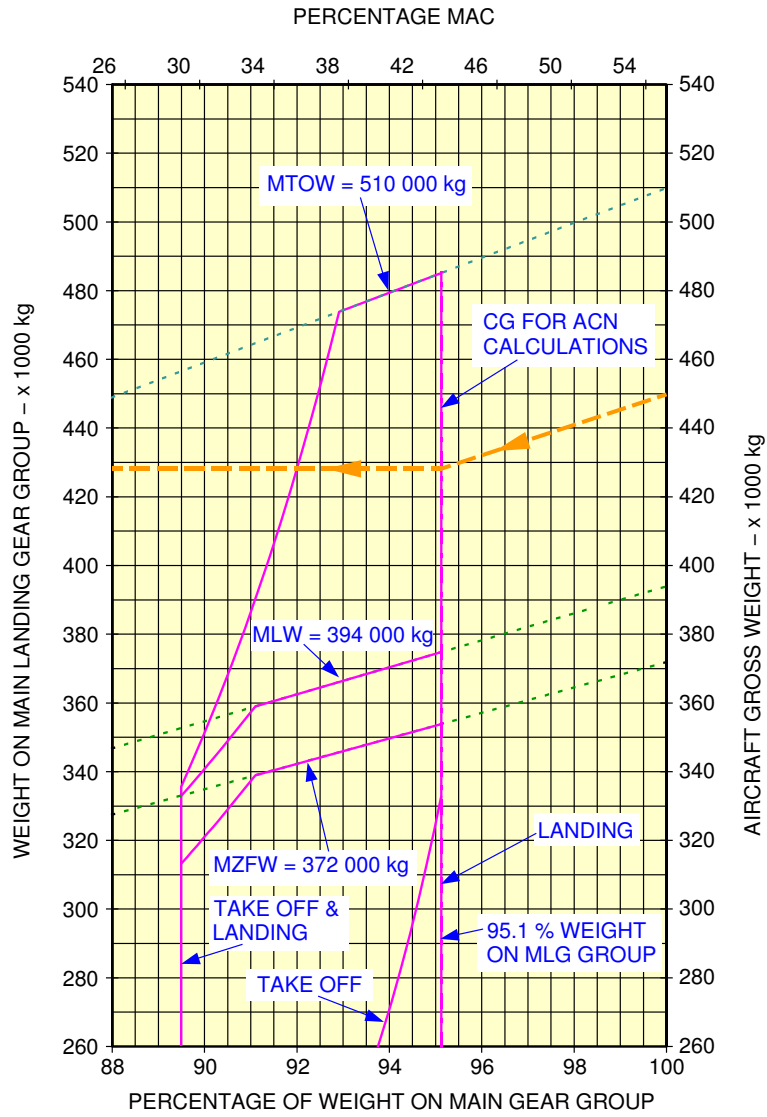

L_AC_070401_1_0050101_01_00

Landing Gear Loading on Pavement
MRW 512 000 kg - A380-800 Models

**ON A/C A380-800 Models

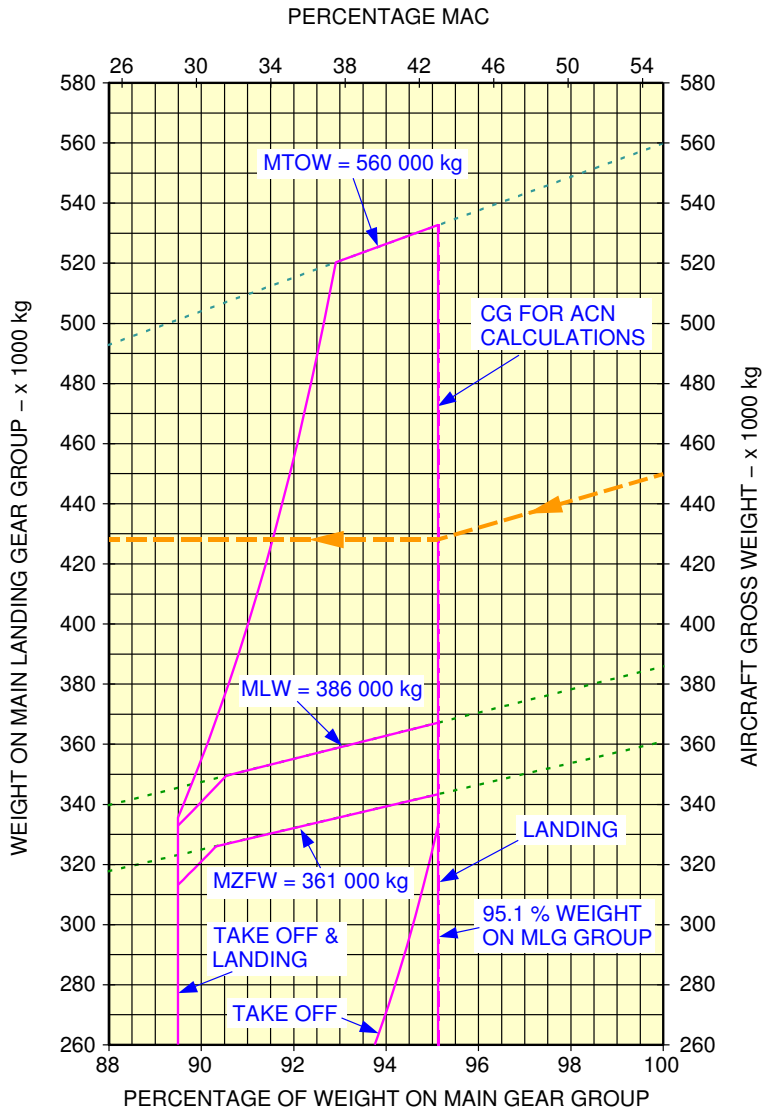

L_AC_070401_1_0060101_01_00

Landing Gear Loading on Pavement
MRW 562 000 kg - A380-800 Models

**ON A/C A380-800 Models

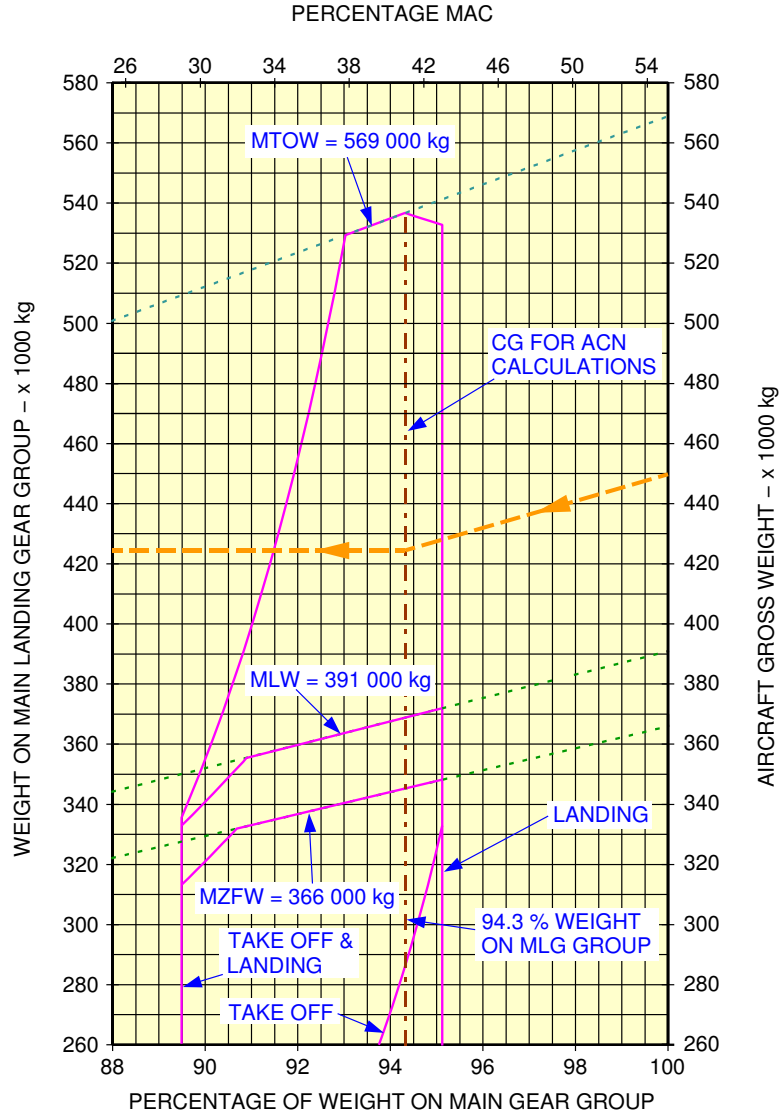

L_AC_070401_1_0070101_01_00

Landing Gear Loading on Pavement
MRW 571 000 kg - A380-800 Models



AIRPLANE CHARACTERISTICS

****ON A/C A380-800F Models**

Landing Gear Loading on Pavement - Freighter

1. This section gives Landing Gear Loading on Pavement.

**ON A/C A380-800F Models

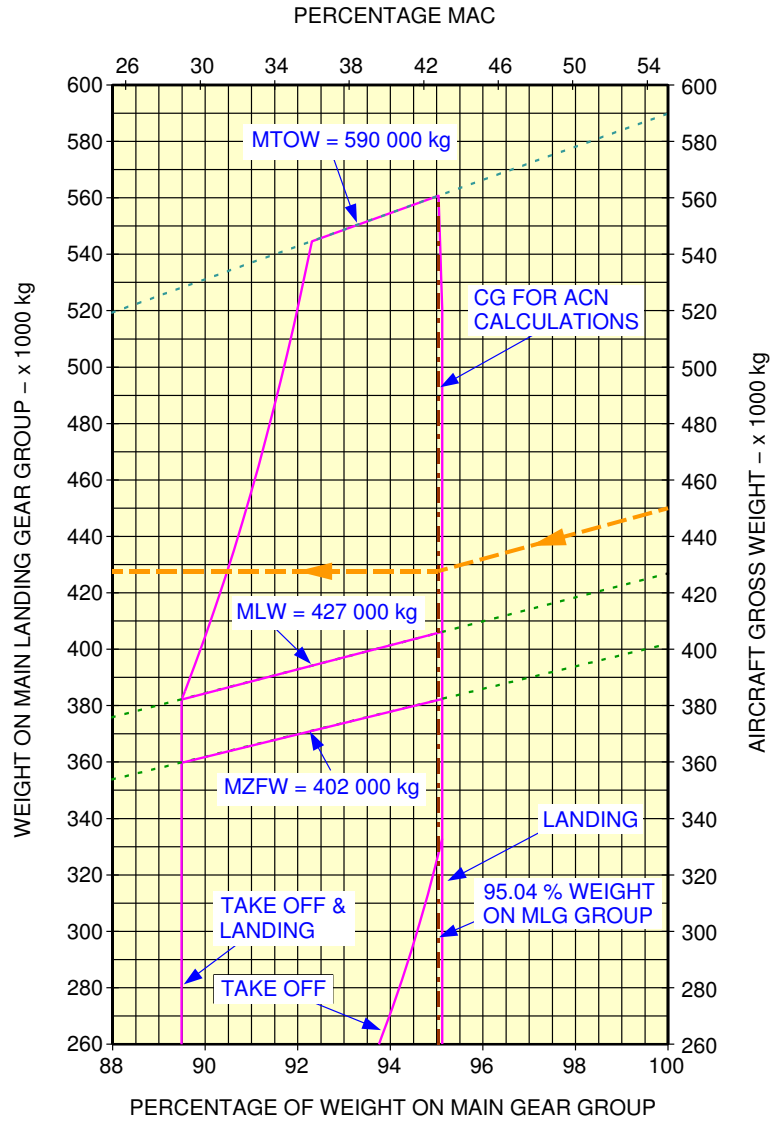

L_AC_070401_1_0080101_01_00

Landing Gear Loading on Pavement
MRW 592 000kg - A380-800F Models

**ON A/C A380-800F Models

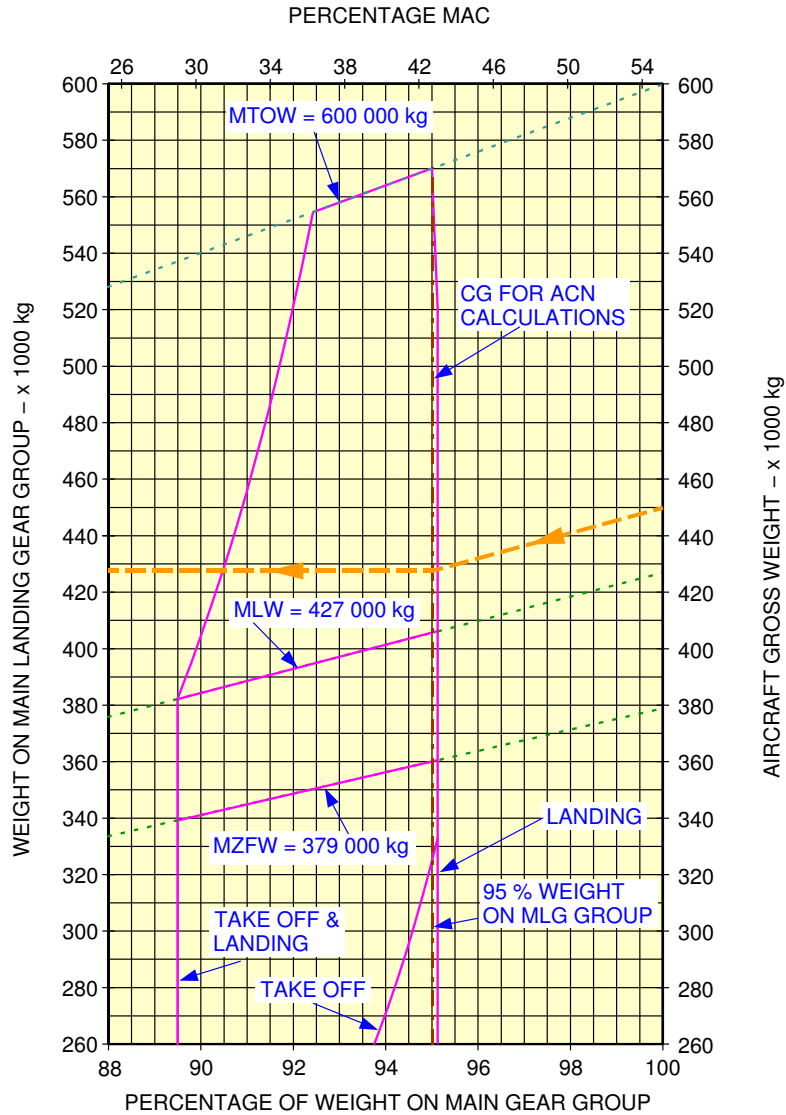

L_AC_070401_1_0090101_01_00

Landing Gear Loading on Pavement
MRW 602 000kg - A380-800F Models

7-4-2 Wing Gear and Body Gear Loading on Pavement

**ON A/C A380-800 Models A380-800F Models

Wing Gear and Body Gear Loading on Pavement

1. General

The Main Landing Gear Group consists of two Wing Gears (4 Wheel Bogies) and two Body Gears (6 Wheel Bogies).

- A380-800 models :

In the example shown in Section 7-4-3 with MRW 512000 kg, the Gross Aircraft Weight is 450000 kg (992080 lb) at Aft CG for ACN Calculations (see Section 7-4-1, Page 1)

For these conditions the load on the two Wing Gears is 171200 kg (377430 lb) and the load on the two Body Gears is 256800 kg (566150 lb).

The total weight on the Main Landing Gear Group is 428000 kg (943580 lb).

In the example shown in Section 7-4-3 with MRW 562000 kg, the Gross Aircraft Weight is 450000 kg (992080 lb) at Aft CG for ACN Calculations (see Section 7-4-1, Page 1)

For these conditions the load on the two Wing Gears is 171200 kg (377430 lb) and the load on the two Body Gears is 256800 kg (566150 lb).

The total weight on the Main Landing Gear Group is 428000 kg (943580 lb).

In the example shown in Section 7-4-3 with MRW 571000 kg, the Gross Aircraft Weight is 450000 kg (992080 lb) at Aft CG for ACN Calculations (see Section 7-4-1, Page 2)

For these conditions the load on the two Wing Gears is 169800 kg (374345 lb) and the load on the two Body Gears is 254700 kg (561515 lb).

The total weight on the Main Landing Gear Group is 424500 kg (935860 lb).

- A380-800F models :

In the example shown in Section 7-4-3 with MRW 592000 kg, the Gross Aircraft Weight is 450000 kg (992080 lb) at Aft CG for ACN Calculations (see Section 7-4-1, Page 3)

For these conditions the load on the two Wing Gears is 171100 kg (377210 lb) and the load on the two Body Gears is 256600 kg (565710 lb).

The total weight on the Main Landing Gear Group is 427700 kg (942920 lb).

In the example shown in Section 7-4-3 with MRW 602000 kg, the Gross Aircraft Weight is 450000 kg (992080 lb) at Aft CG for ACN Calculations (see Section 7-4-1, Page 4)

For these conditions the load on the two Wing Gears is 171000 kg (376990 lb) and the load on the two Body Gears is 256500 kg (565485 lb).

The total weight on the Main Landing Gear Group is 427500 kg (942475 lb).



AIRPLANE CHARACTERISTICS

7-4-3 Wing Gear and Body Gear Loading on Pavement

****ON A/C A380-800 Models**

Wing Gear and Body Gear Loading on Pavement - Pax

1. This section gives the Wing Gear and Body Gear Loading on Pavement.

****ON A/C A380-800 Models**

CG FOR ACN CALCULATIONS: 43 % MAC.
 See Section 7-4-1 Figure: Landing Gear Loading
 on Pavement – MRW 512 000 kg – A380-800 Models

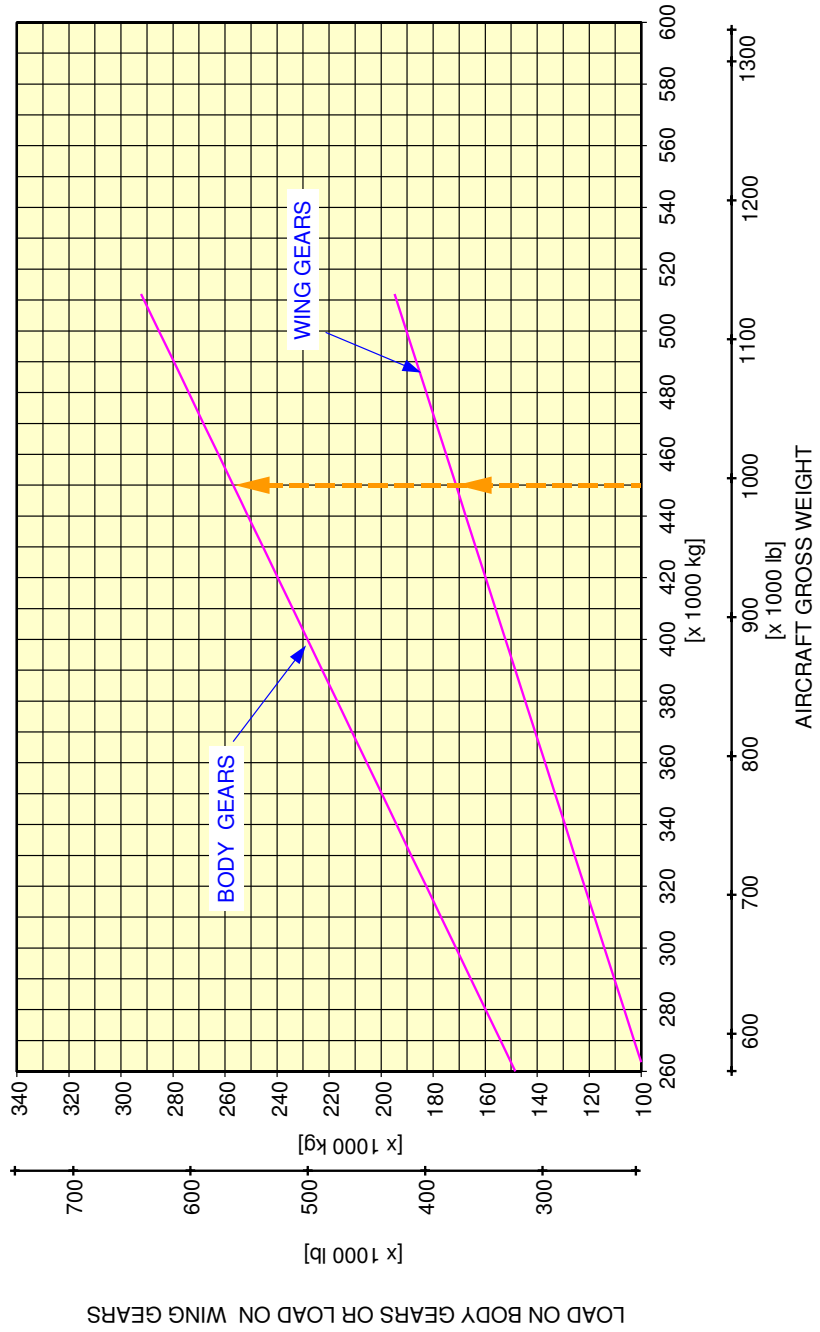

L_AC_070403_1_0050101_01_00

Wing Gear and Body Gear Loads on Pavement
 MRW 512 000 kg - A380-800 Models

****ON A/C A380-800 Models**

CG FOR ACN CALCULATIONS: 43 % MAC.
 See Section 7-4-1 Figure: Landing Gear Loading
 on Pavement – MRW 562 000 kg – A380-800 Models

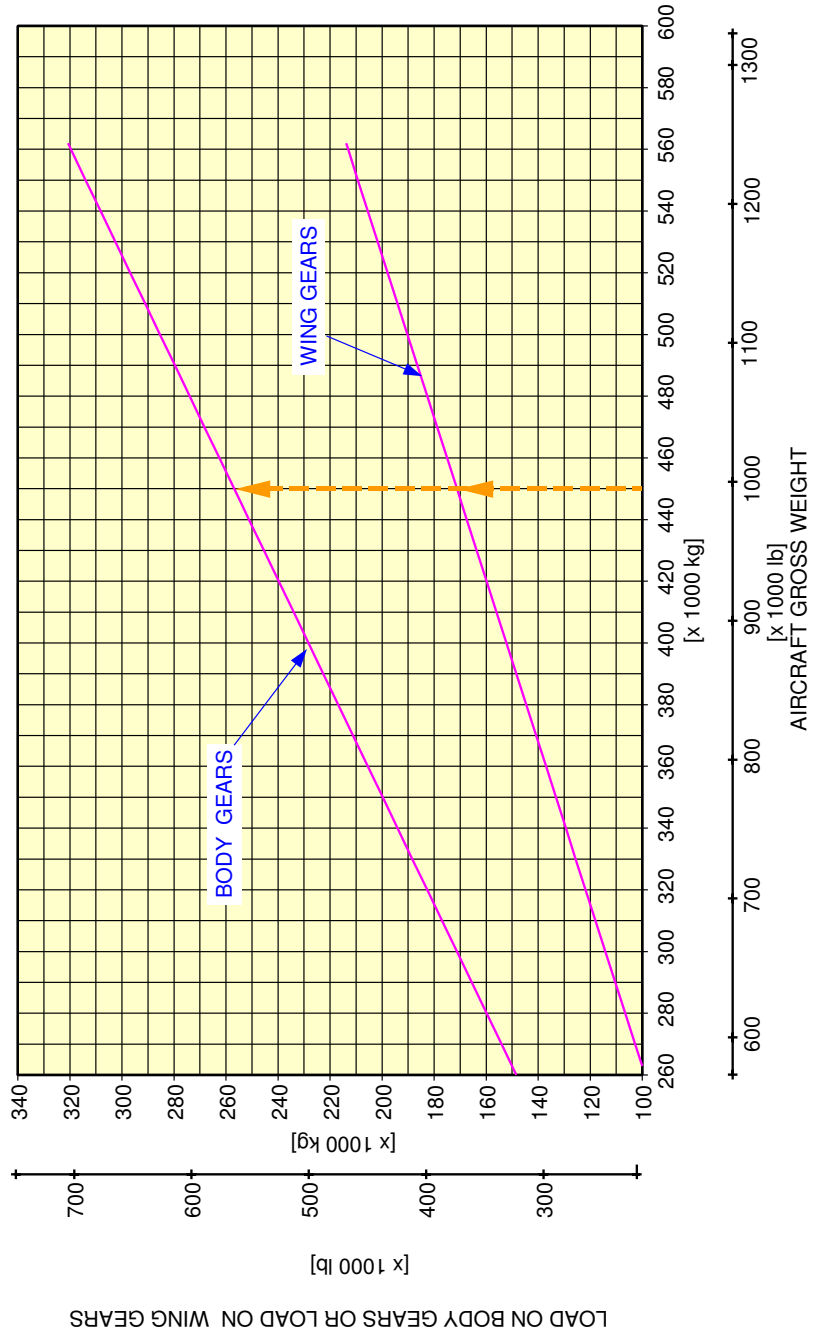

L_AC_070403_1_0060101_01_00

Wing Gear and Body Gear Loads on Pavement
 MRW 562 000 kg - A380-800 Models

****ON A/C A380-800 Models**

CG FOR ACN CALCULATIONS: 41 % MAC.
 See Section 7-4-1 Figure: Landing Gear Loading
 on Pavement – MRW 571 000 kg – A380-800 Models

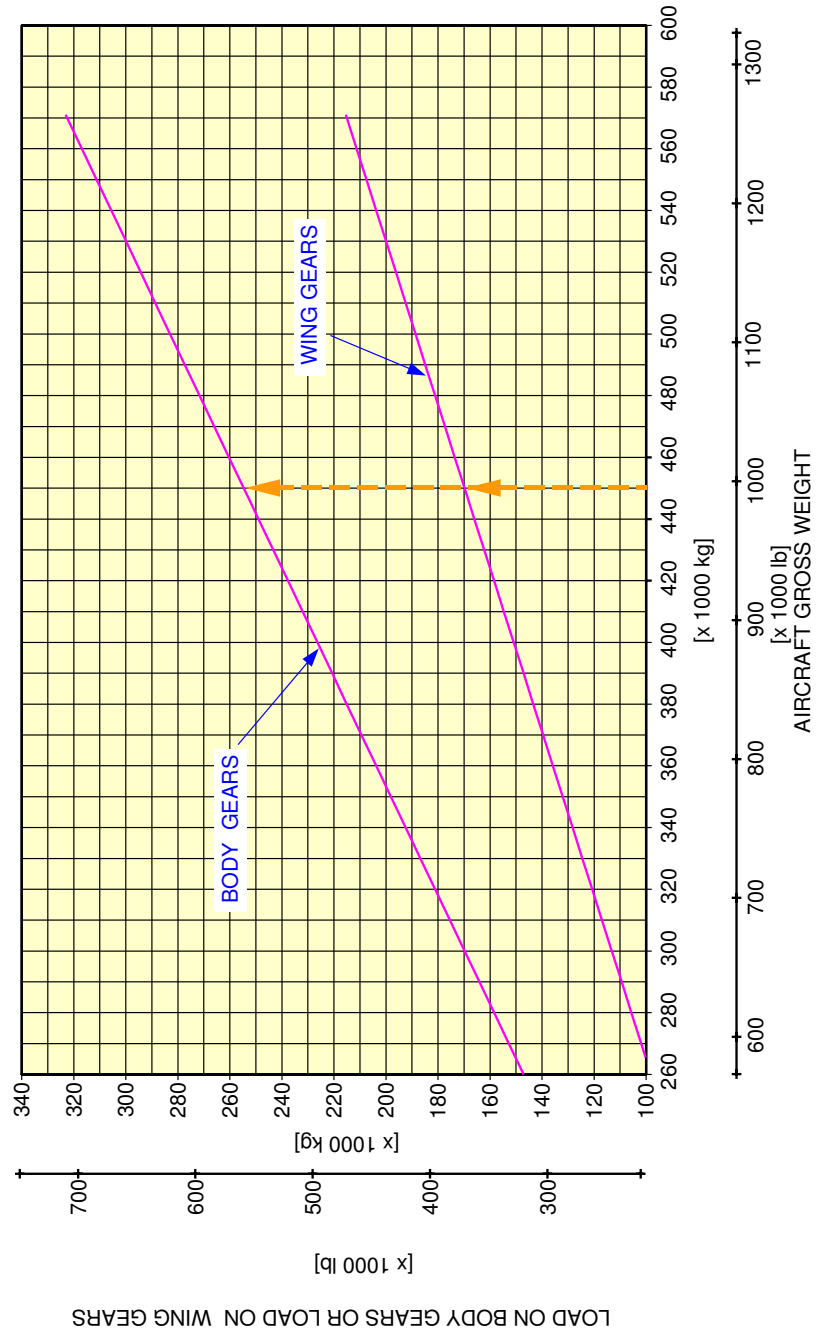

L_AC_070403_1_0070101_01_00

Wing Gear and Body Gear Loads on Pavement
 MRW 571 000 kg - A380-800 Models



AIRPLANE CHARACTERISTICS

****ON A/C A380-800F Models**

Wing Gear and Body Gear Loading on Pavement - Freighter

1. This section gives the Wing Gear and Body Gear Loading on Pavement.

****ON A/C A380-800F Models**

CG FOR ACN CALCULATIONS: 42.8 % MAC.
 See Section 7-4-1 Figure: Landing Gear Loading
 on Pavement - MRW 592 000 kg - A380-800F Models

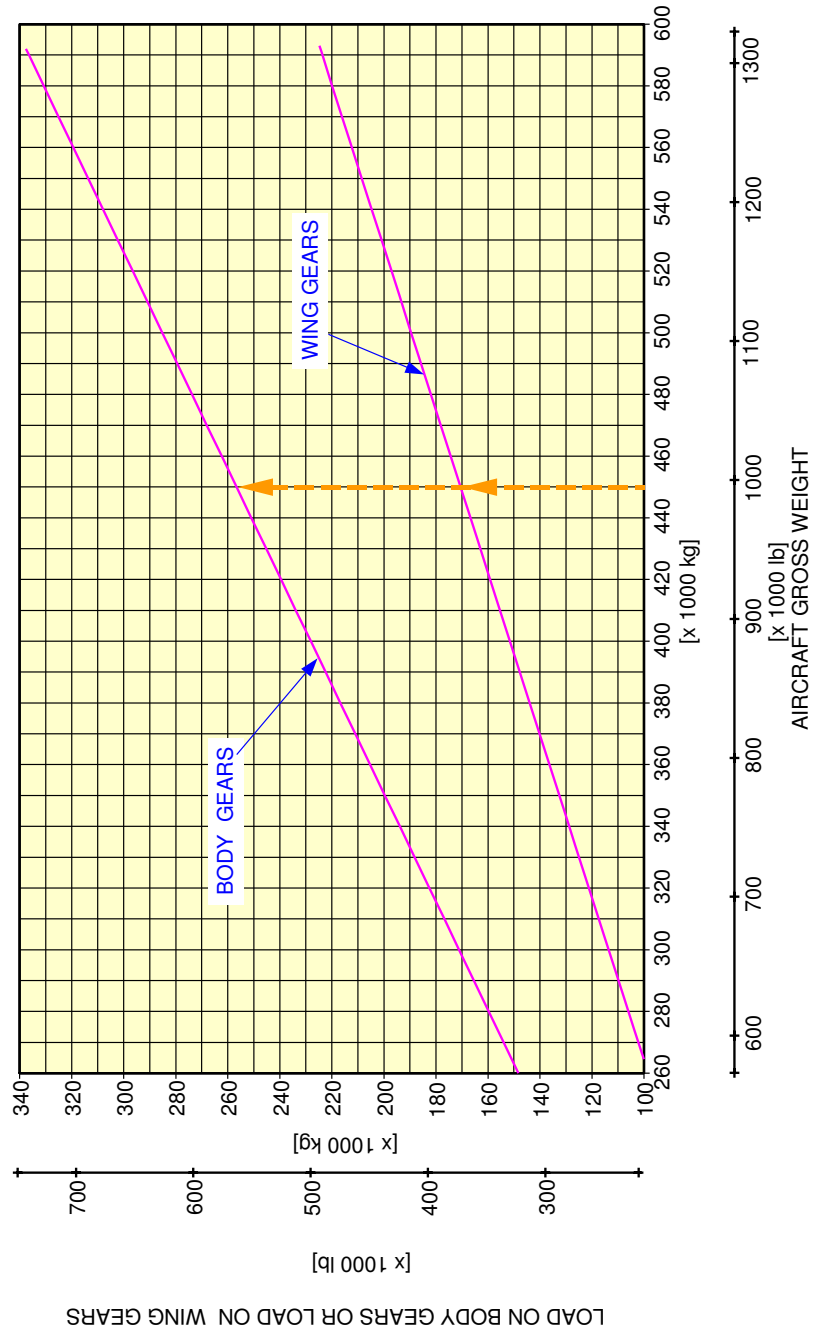

L_AC_070403_1_0080101_01_00

Wing Gear and Body Gear Loads on Pavement
 MRW 592 000 kg - A380-800F Models

****ON A/C A380-800F Models**

CG FOR ACN CALCULATIONS: 42.7 % MAC.
 See Section 7-4-1 Figure: Landing Gear Loading
 on Pavement – MRW 602 000 kg – A380-800F Models

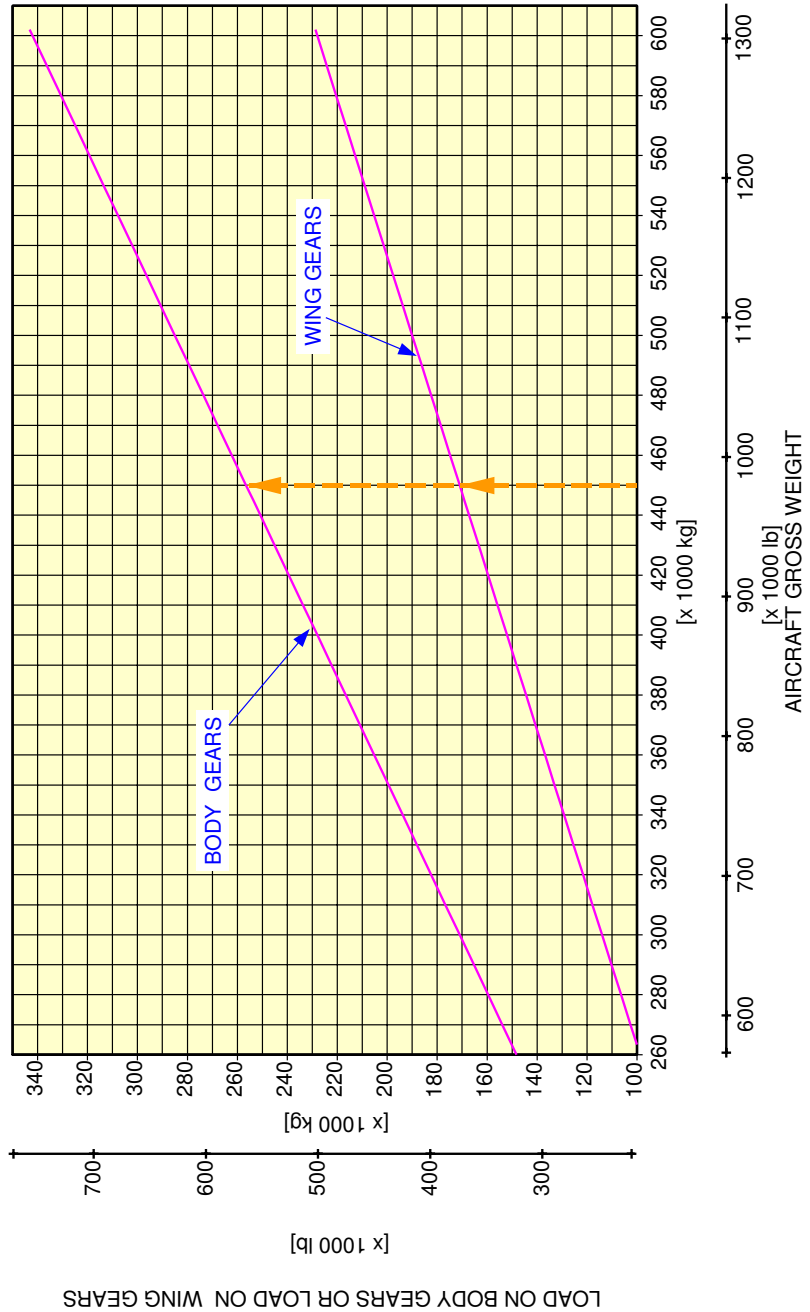

L_AC_070403_1_0090101_01_00

Wing Gear and Body Gear Loads on Pavement
 MRW 602 000 kg - A380-800F Models

7-5-0 Flexible Pavement Requirements - US Army Corps of Engineers Design Method

****ON A/C A380-800 Models A380-800F Models**

Flexible Pavement Requirements - US Army Corps of Engineers Design Method

1. General

To find a Flexible Pavement Thickness, the Subgrade Strength (CBR), the Annual Departure Level and the weight on one Main Landing Gear must be known.

In the example shown in Section 7-5-1 with MRW 512000 kg, for:

- a CBR value of 10
- an Annual Departure level of 3 000
- and the load on one Wing Landing Gear of 90000 kg (198420 lb) the required Flexible Pavement Thickness is 54 cm (21 inches).

The line showing 10 000 Coverages is used to calculate Aircraft Classification Number (ACN).



AIRPLANE CHARACTERISTICS

7-5-1 Flexible Pavement Requirements - US Army Corps of Engineers Design Method S-77-1

****ON A/C A380-800 Models**

Flexible Pavement Requirements - US Army Corps of Engineers Design Method - Pax

1. This section gives Flexible Pavement Requirements.

**ON A/C A380-800 Models

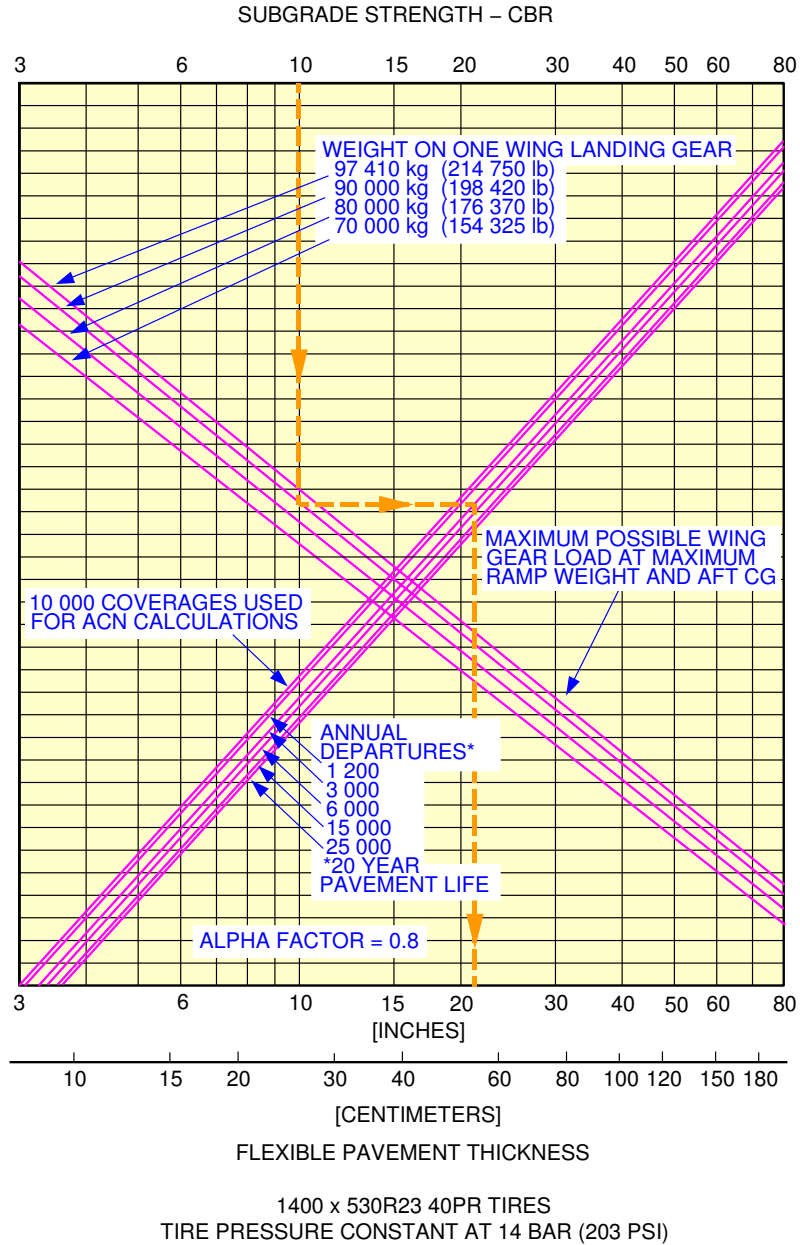

L_AC_070501_1_0090101_01_00

Flexible Pavement Requirements – 4 Wheel Bogie
 MRW 512 000 kg - A380-800 Models

**ON A/C A380-800 Models

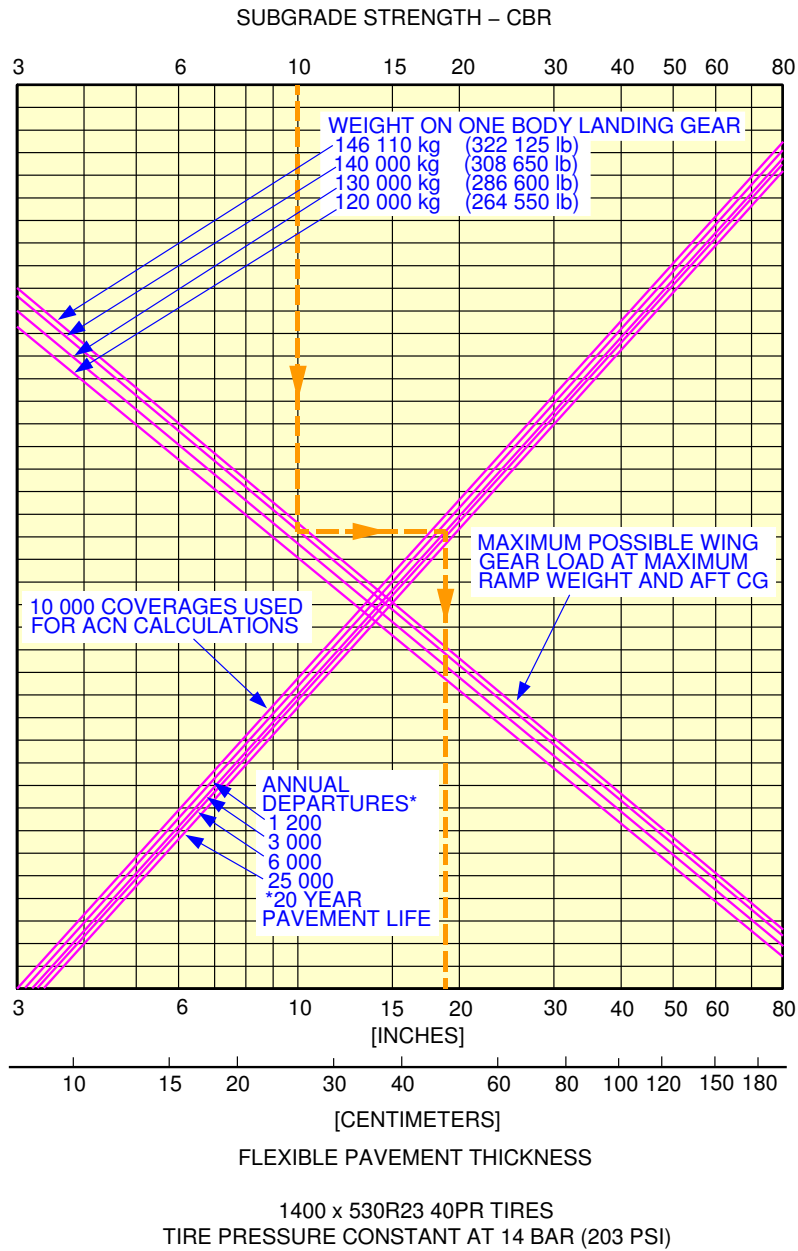

L_AC_070501_1_0100101_01_00

Flexible Pavement Requirements – 6 Wheel Bogie
MRW 512 000 kg - A380-800 Models

**ON A/C A380-800 Models

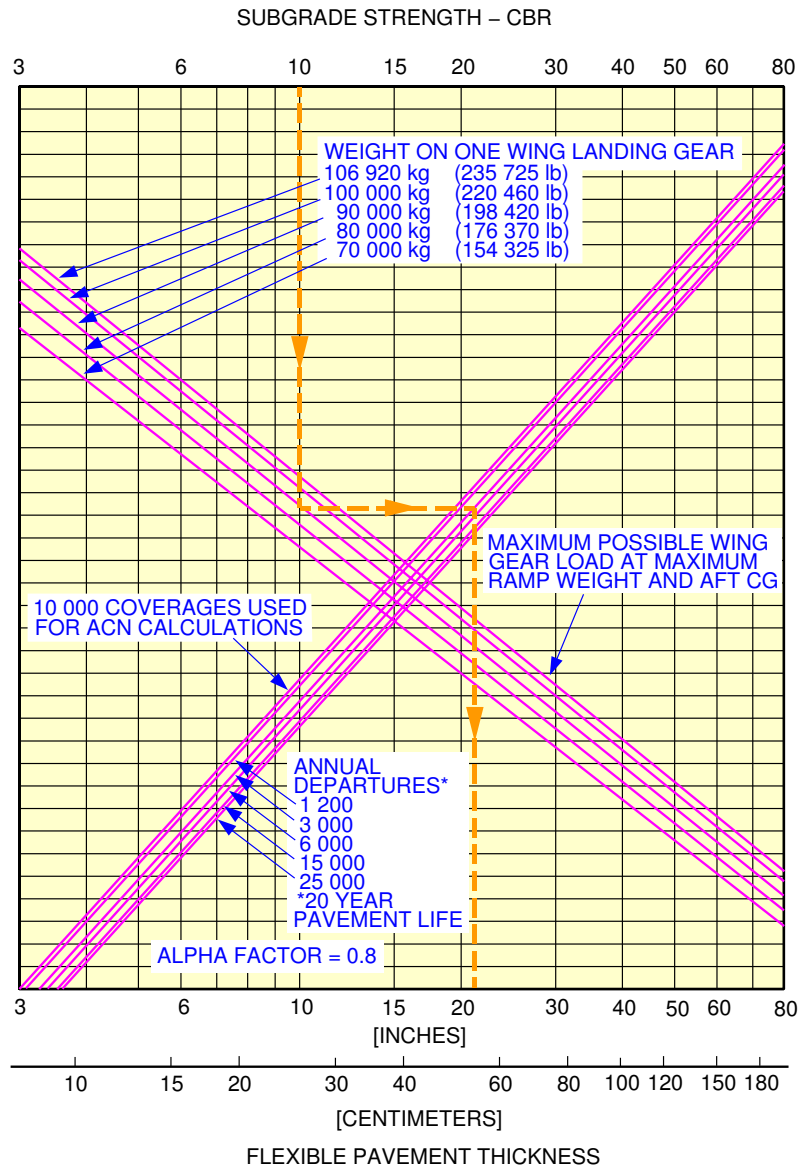

1400 x 530R23 40PR TIRES
TIRE PRESSURE CONSTANT AT 15 BAR (218 PSI)

L_AC_070501_1_0110101_01_00

Flexible Pavement Requirements – 4 Wheel Bogie
MRW 562 000 kg - A380-800 Models

**ON A/C A380-800 Models

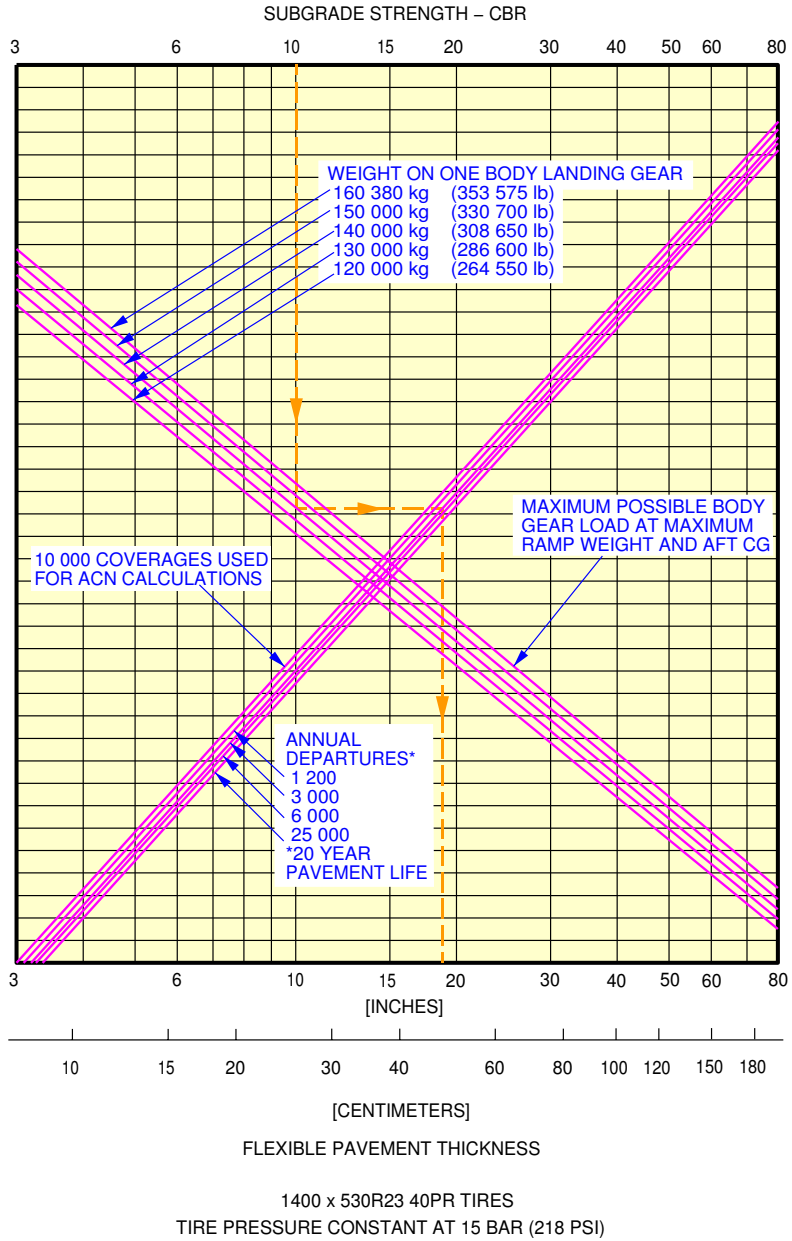

L_AC_070501_1_0020101_01_01

Flexible Pavement Requirements – 6 Wheel Bogie
MRW 562 000 kg - A380-800 Models

**ON A/C A380-800 Models

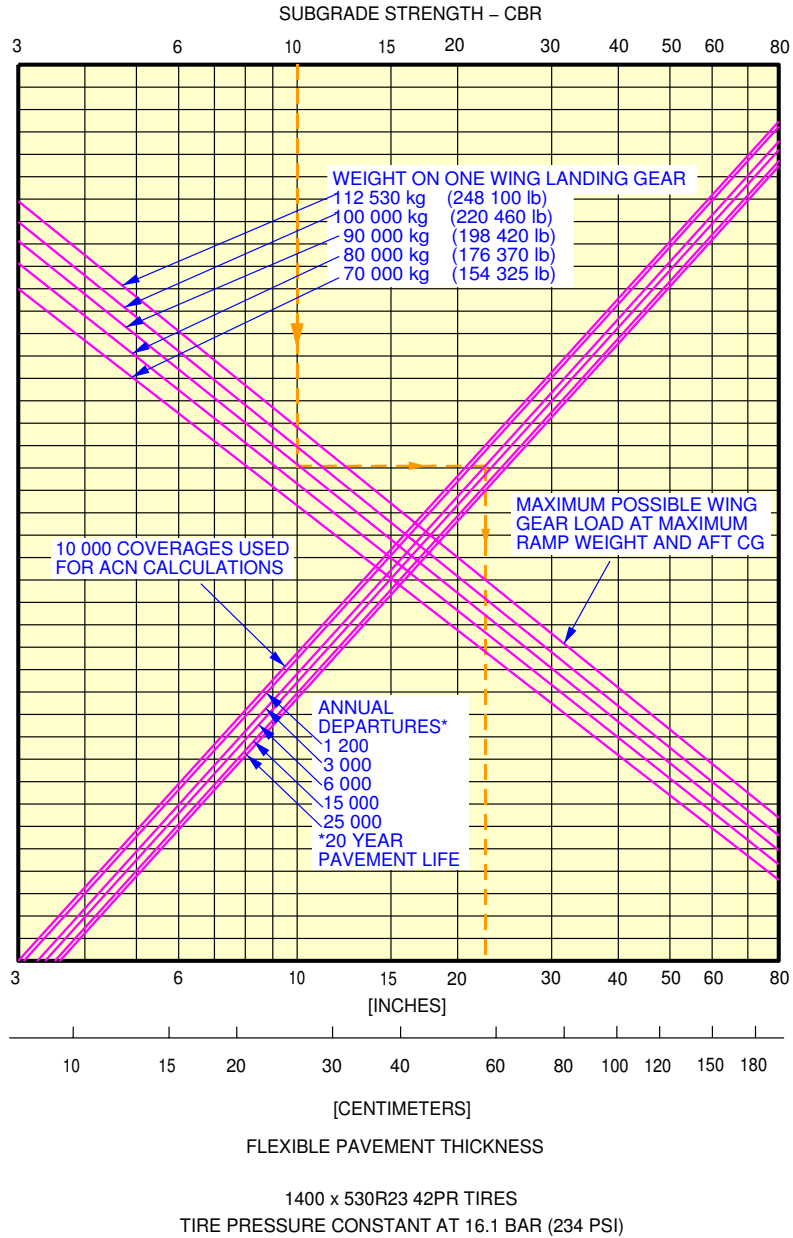

L_AC_070501_1_0120101_01_00

Flexible Pavement Requirements – 4 Wheel Bogie
MRW 571 000 kg - A380-800 Models

**ON A/C A380-800 Models

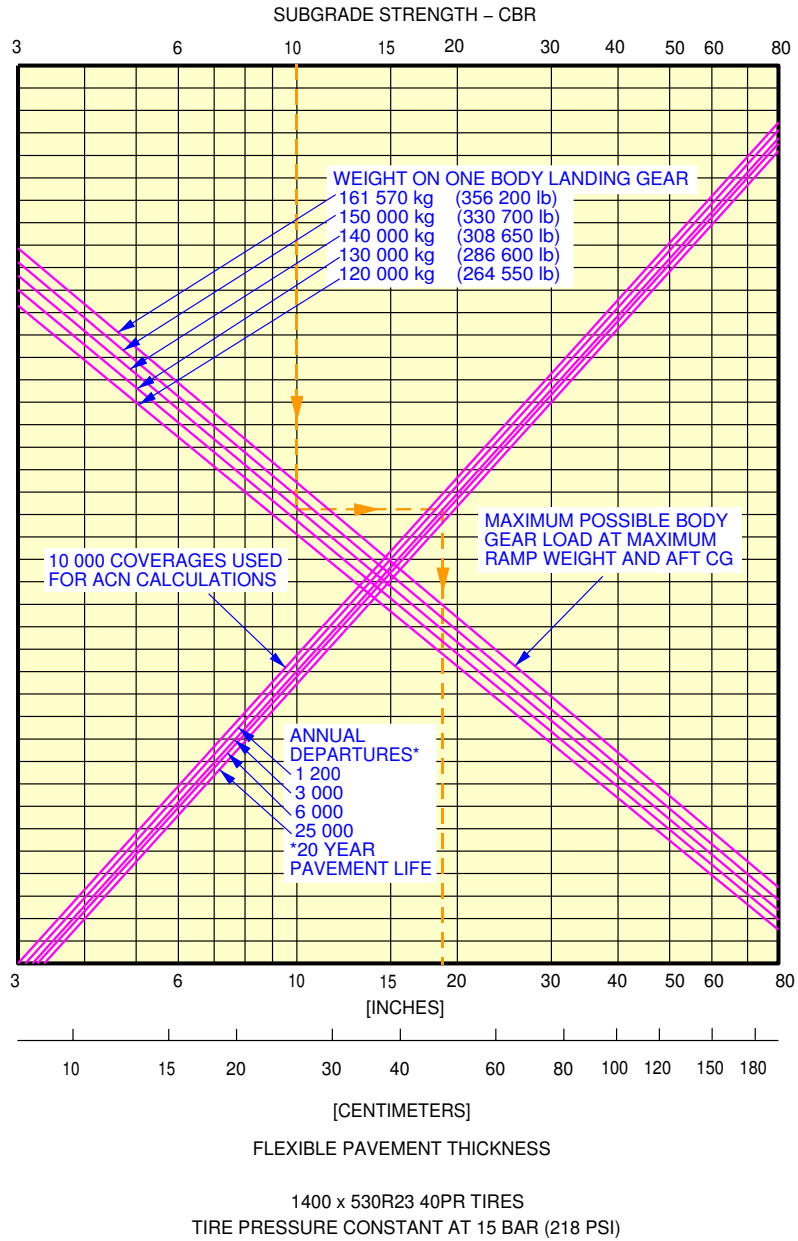

L_AC_070501_1_0060101_01_00

Flexible Pavement Requirements – 6 Wheel Bogie
MRW 571 000 kg - A380-800 Models



AIRPLANE CHARACTERISTICS

****ON A/C A380-800F Models**

Flexible Pavement Requirements - US Army Corps of Engineers Design Method - Freighter

1. This section gives Flexible Pavement Requirements.

****ON A/C A380-800F Models**

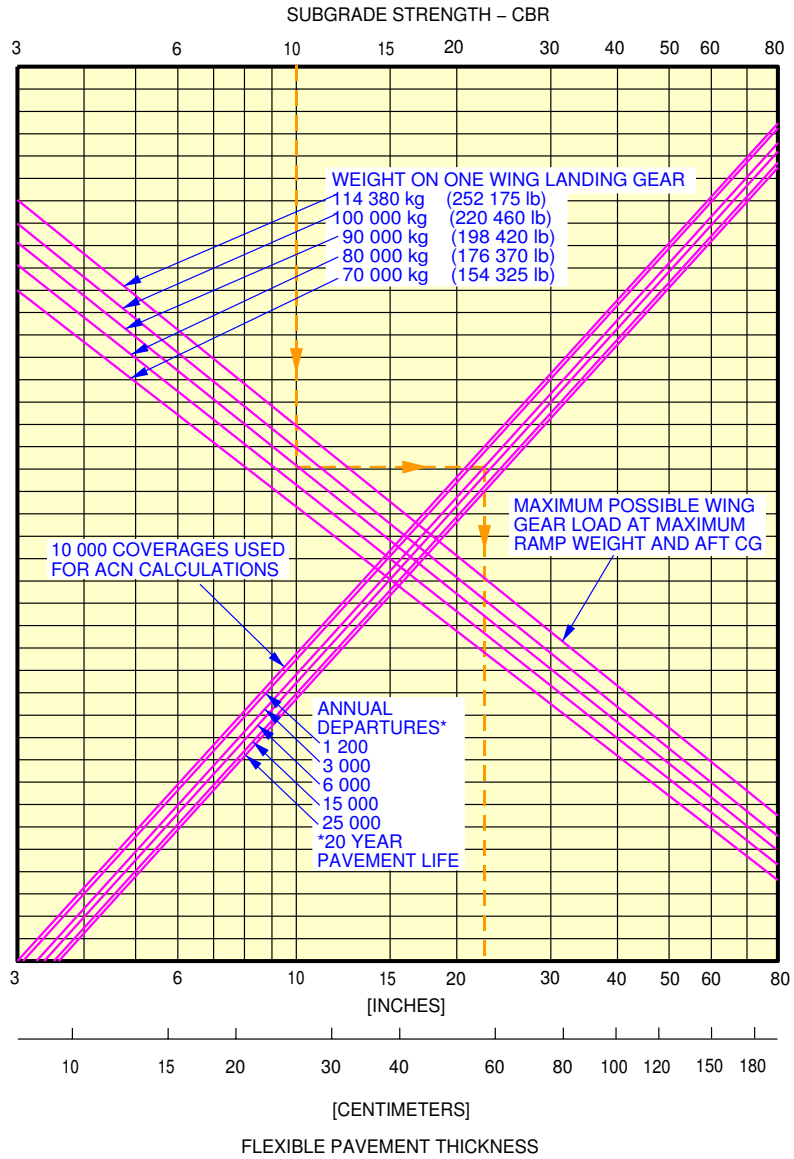

1400 x 530R23 42PR TIRES
TIRE PRESSURE CONSTANT AT 16.1 BAR (234 PSI)

L_AC_070501_1_0130101_01_00

Flexible Pavement Requirements – 4 Wheel Bogie
MRW 592 000 kg - A380-800F Models

****ON A/C A380-800F Models**

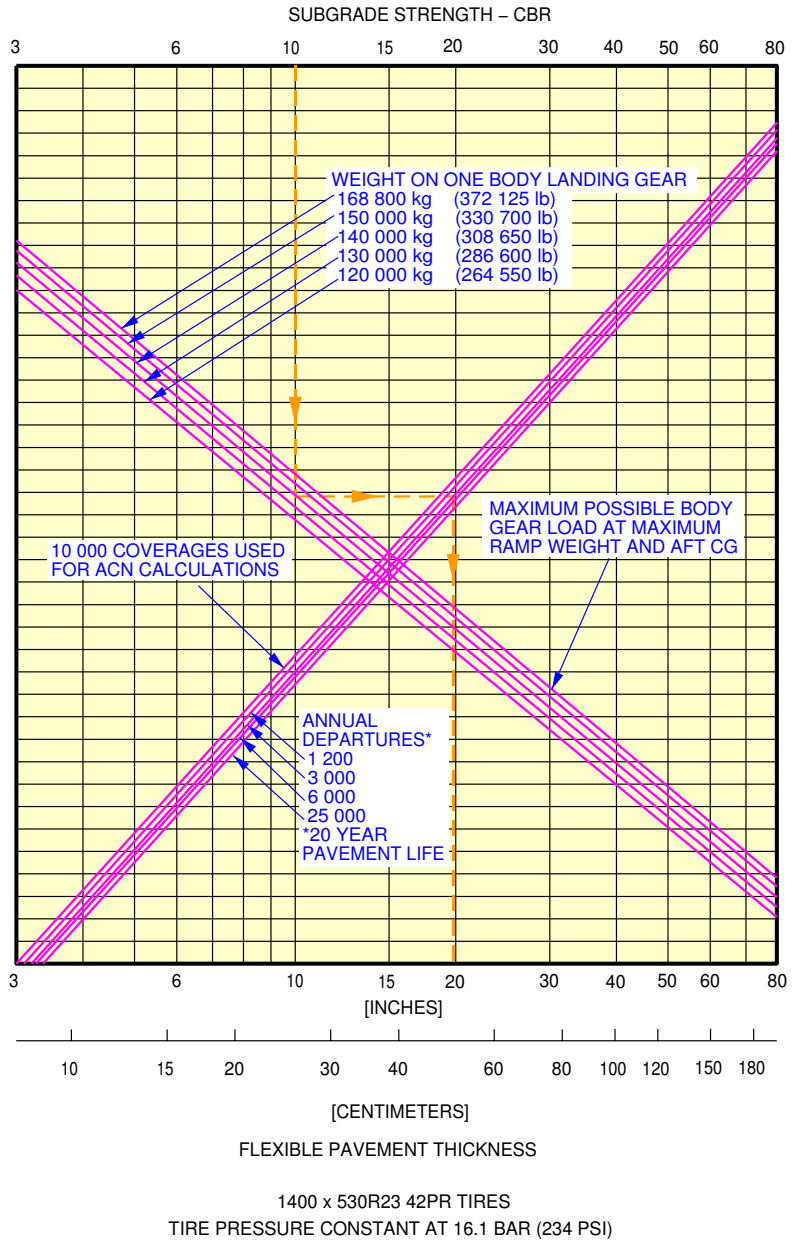

L_AC_070501_1_0040101_01_01

Flexible Pavement Requirements – 6 Wheel Bogie
MRW 592 000 kg - A380-800F Models

****ON A/C A380-800F Models**

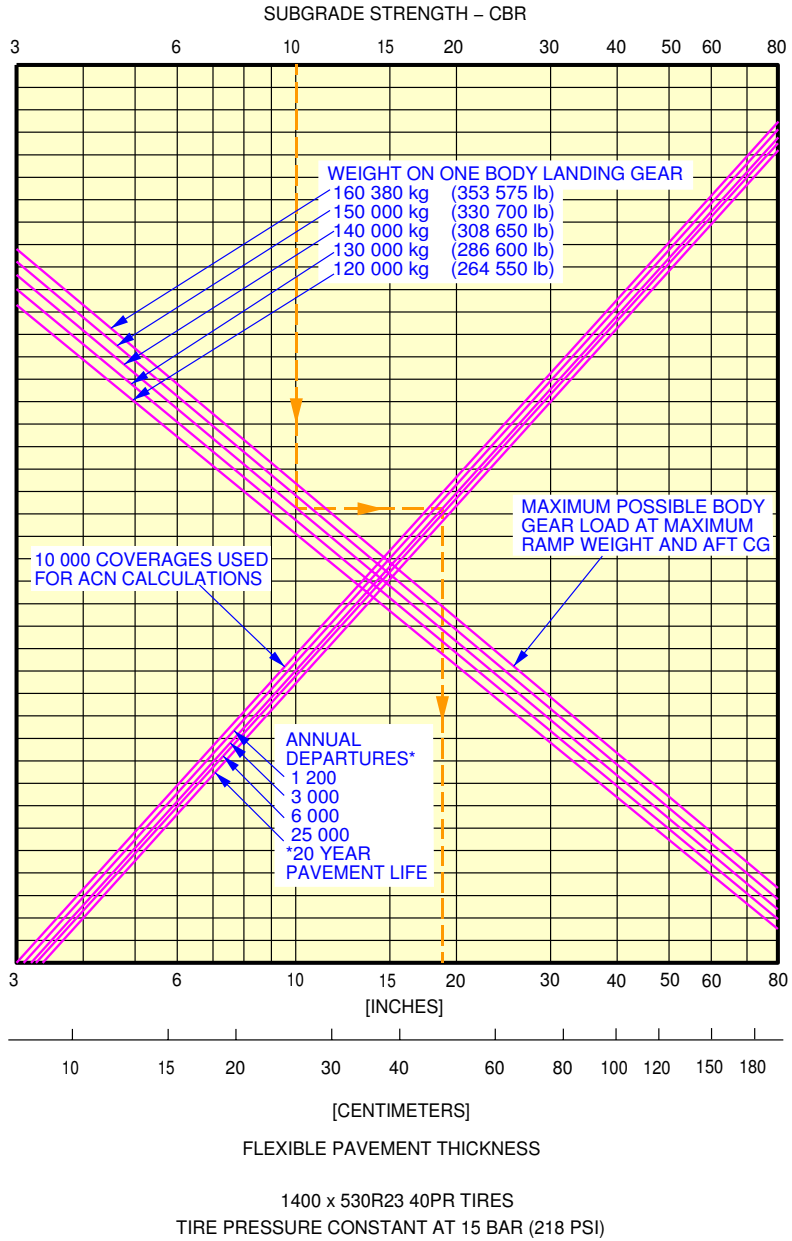

L_AC_070501_1_0140101_01_00

Flexible Pavement Requirements – 4 Wheel Bogie
MRW 602 000 kg - A380-800F Models

****ON A/C A380-800F Models**

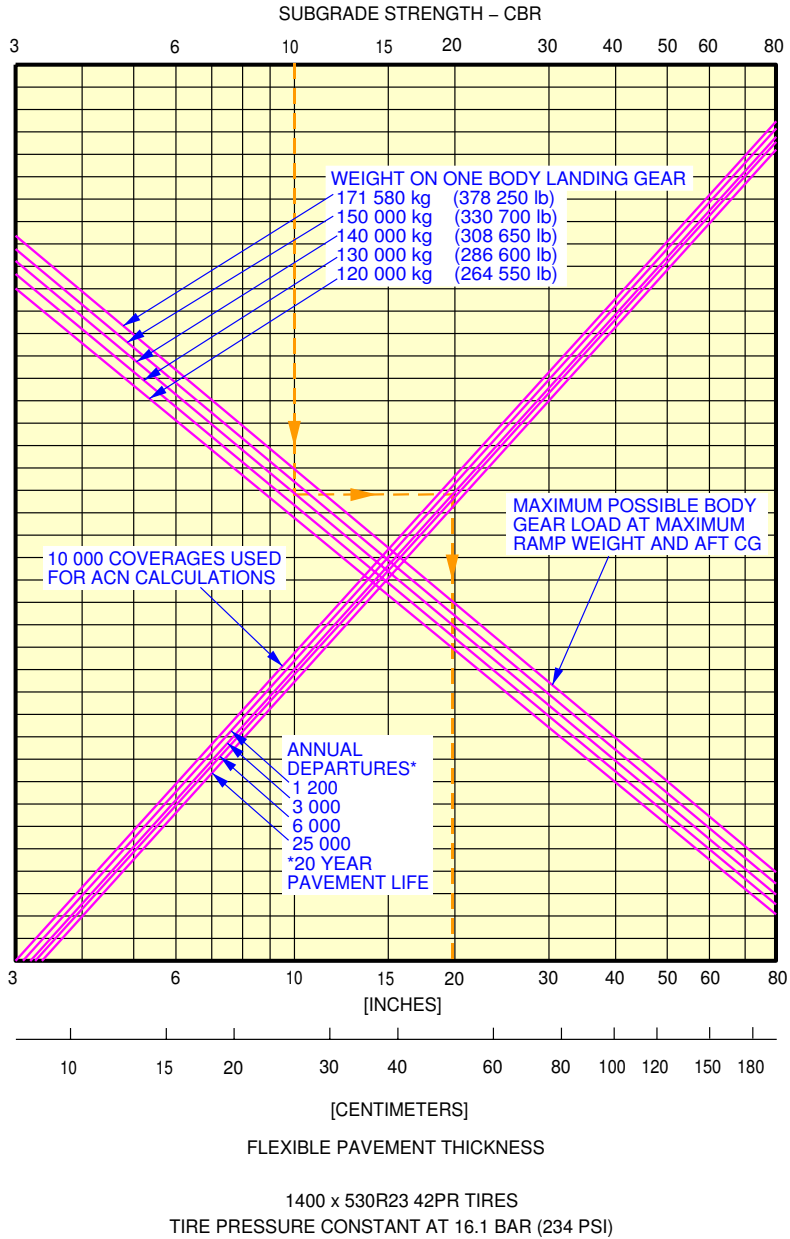

L_AC_070501_1_0080101_01_00

Flexible Pavement Requirements – 6 Wheel Bogie
MRW 602 000 kg - A380-800F Models

7-6-0 Flexible Pavement Requirements - LCN Conversion

****ON A/C A380-800 Models A380-800F Models**

General

1. To find the airplane weight that a Flexible Pavement can support, the LCN of the pavement and the thickness (h) must be known.

In the typical example shown in Section 7-6-1 with MRW 512000 kg, the thickness (h) is shown at 508 mm (20 in.) with an LCN of 82. For these conditions the weight on one Wing Landing Gear is 90000 kg (198420 lb).



AIRPLANE CHARACTERISTICS

7-6-1 Flexible Pavement Requirements - LCN Conversion

****ON A/C A380-800 Models**

Flexible Pavement Requirements - LCN Conversion - Pax

1. This section gives Flexible Pavement Requirements - LCN Conversion.

****ON A/C A380-800 Models**

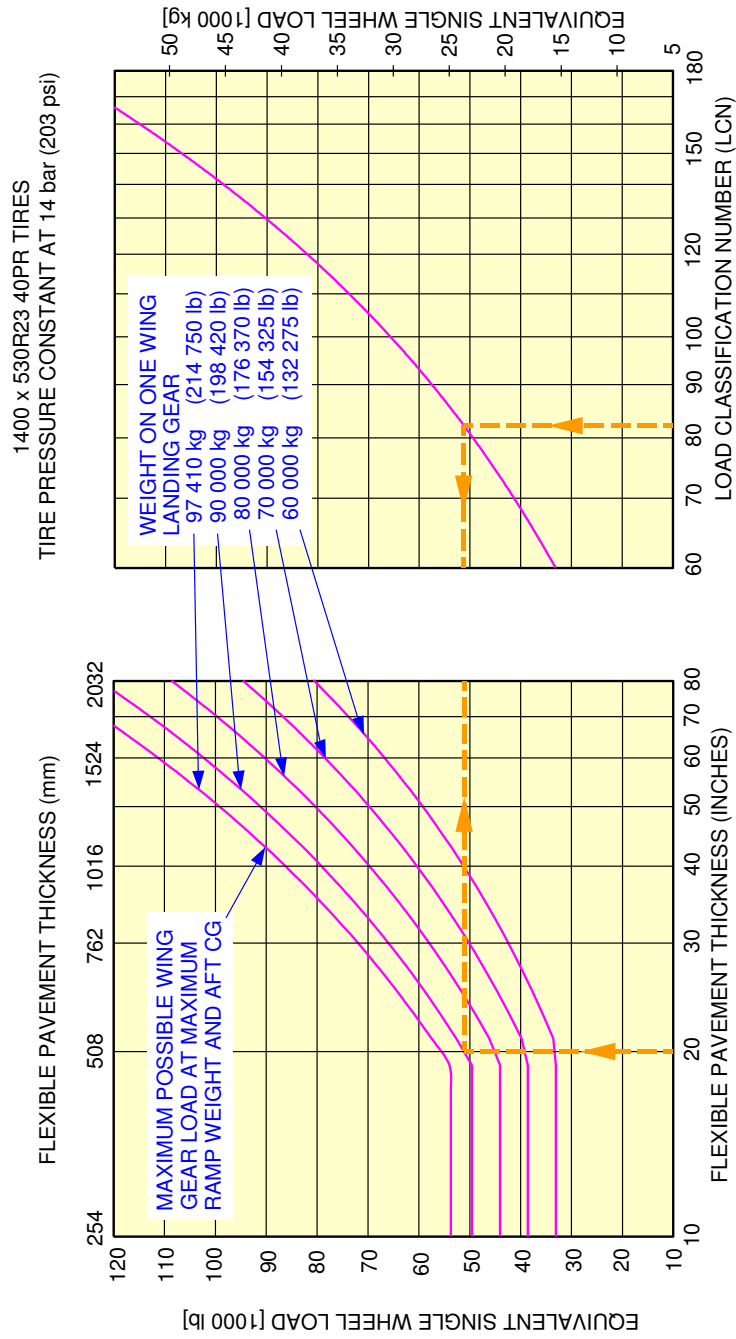

NOTE: EQUIVALENT SINGLE WHEEL LOADS ARE DERIVED BY METHODS SHOWN IN ICAO AERODROME MANUAL PART 2 PAR 4.1.3 Second Edition 1965

L_AC_070601_1_0090101_01_00

Flex Pavement Requirements LCN - 4 Wheel Bogie
MRW 512 000 kg - A380-800 Models

**ON A/C A380-800 Models

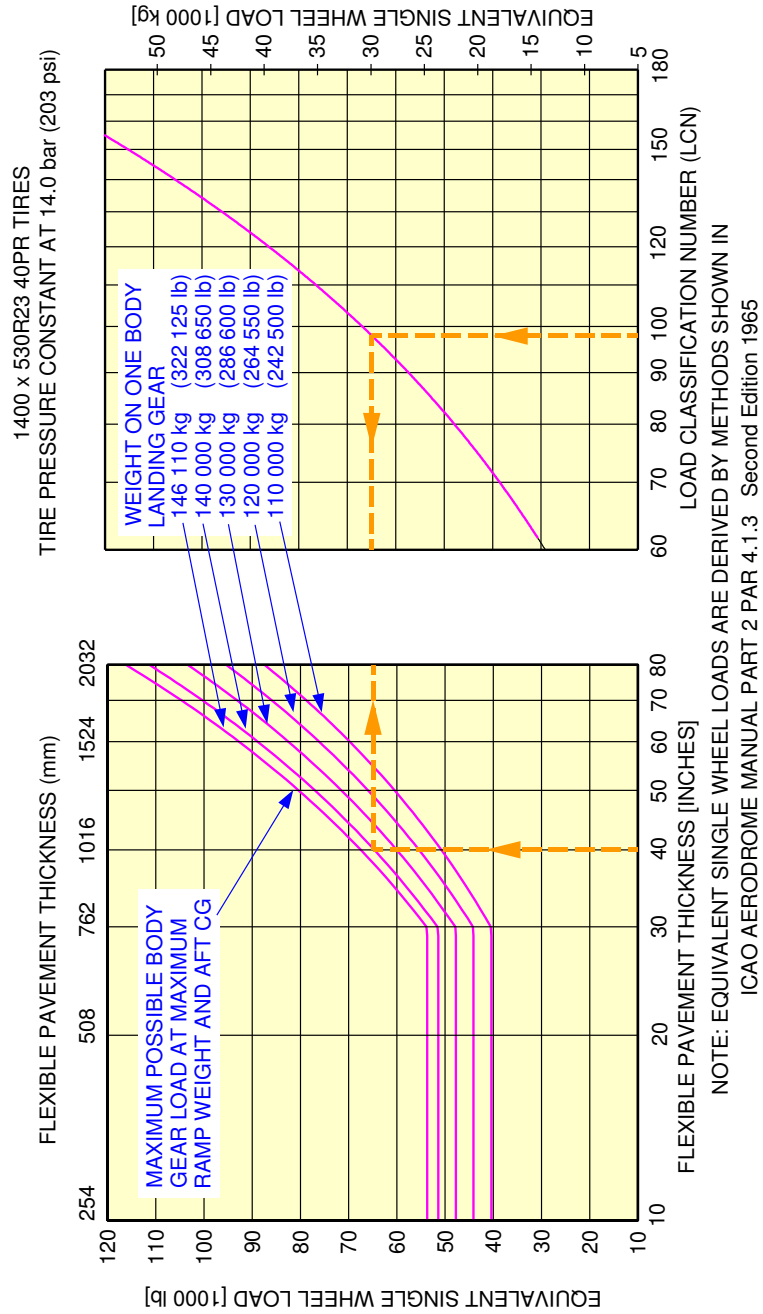

L_AC_070601_1_0100101_01_00

Flex Pavement Requirements LCN - 6 Wheel Bogie
MRW 512 000 kg - A380-800 Models

****ON A/C A380-800 Models**

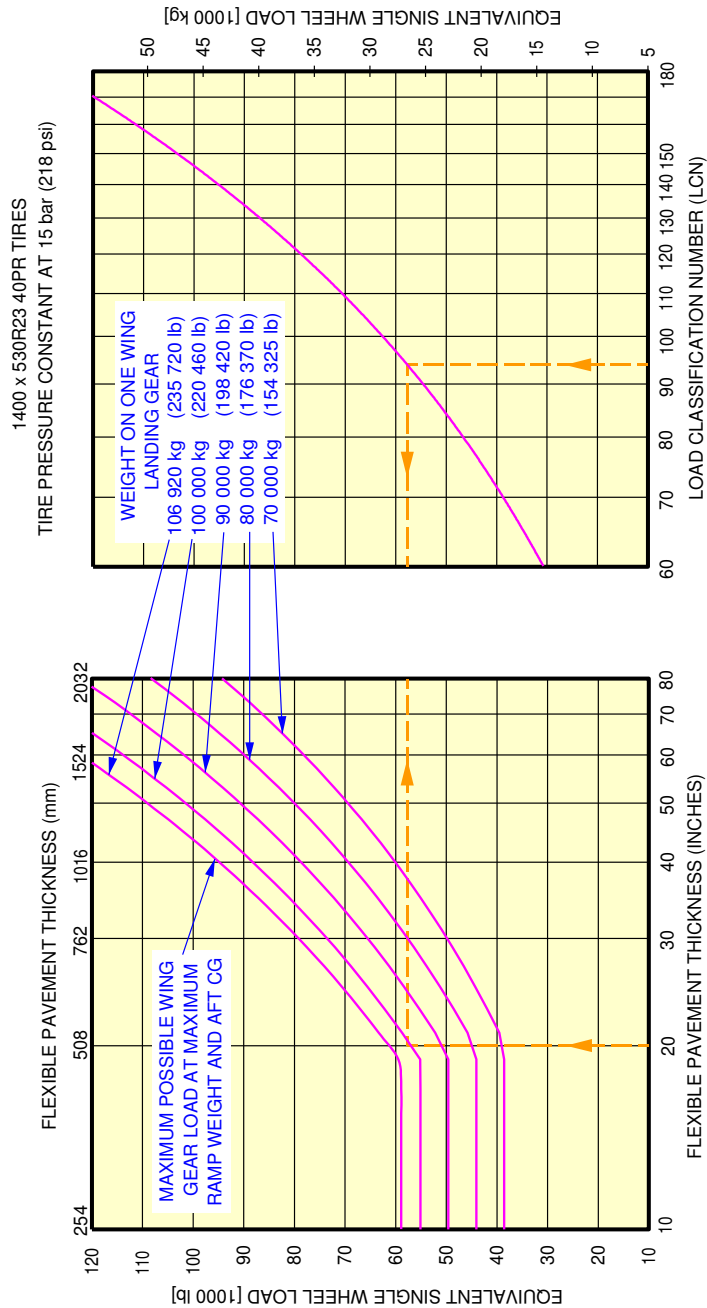

L_AC_070601_1_0010101_01_01

Flex Pavement Requirements LCN - 4 Wheel Bogie
MRW 562 000 kg - A380-800 Models

****ON A/C A380-800 Models**

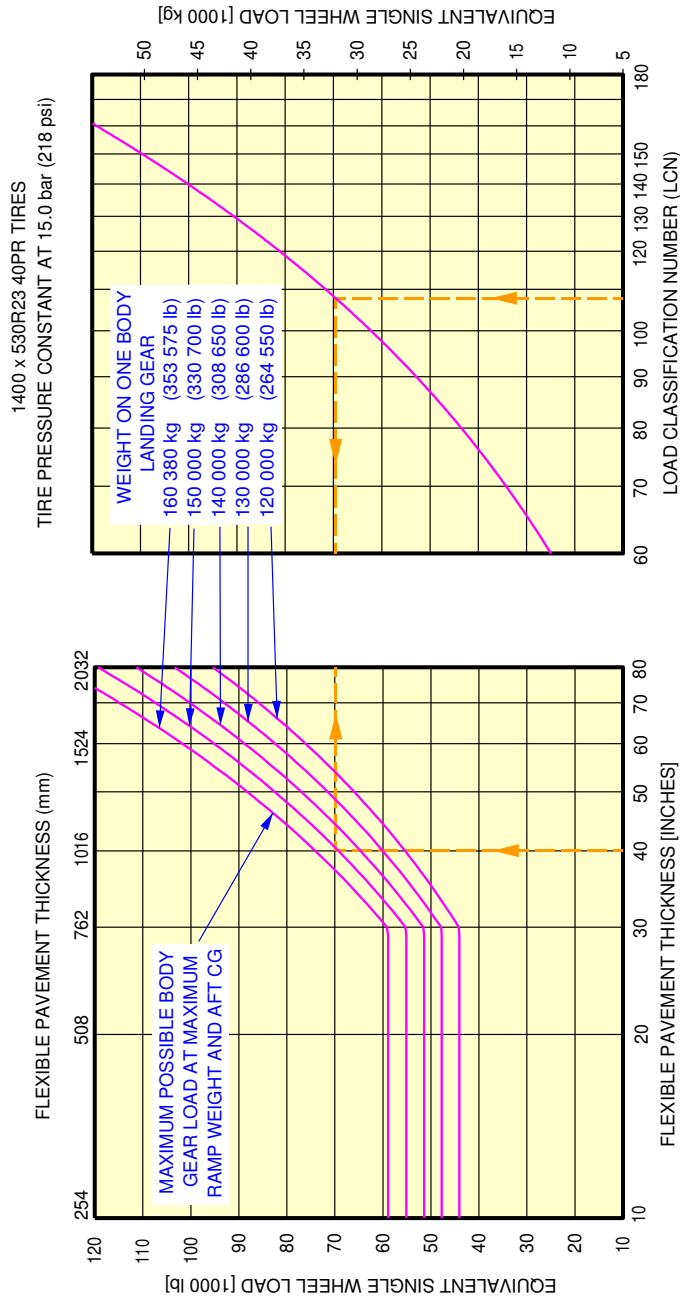

NOTE: EQUIVALENT SINGLE WHEEL LOADS ARE DERIVED BY METHODS SHOWN IN ICAO AERODROME MANUAL PART 2 PAR 4.1.3 Second Edition 1965

L_AC_070601_1_0020101_01_01

Flex Pavement Requirements LCN - 6 Wheel Bogie
MRW 562 000 kg - A380-800 Models

****ON A/C A380-800 Models**

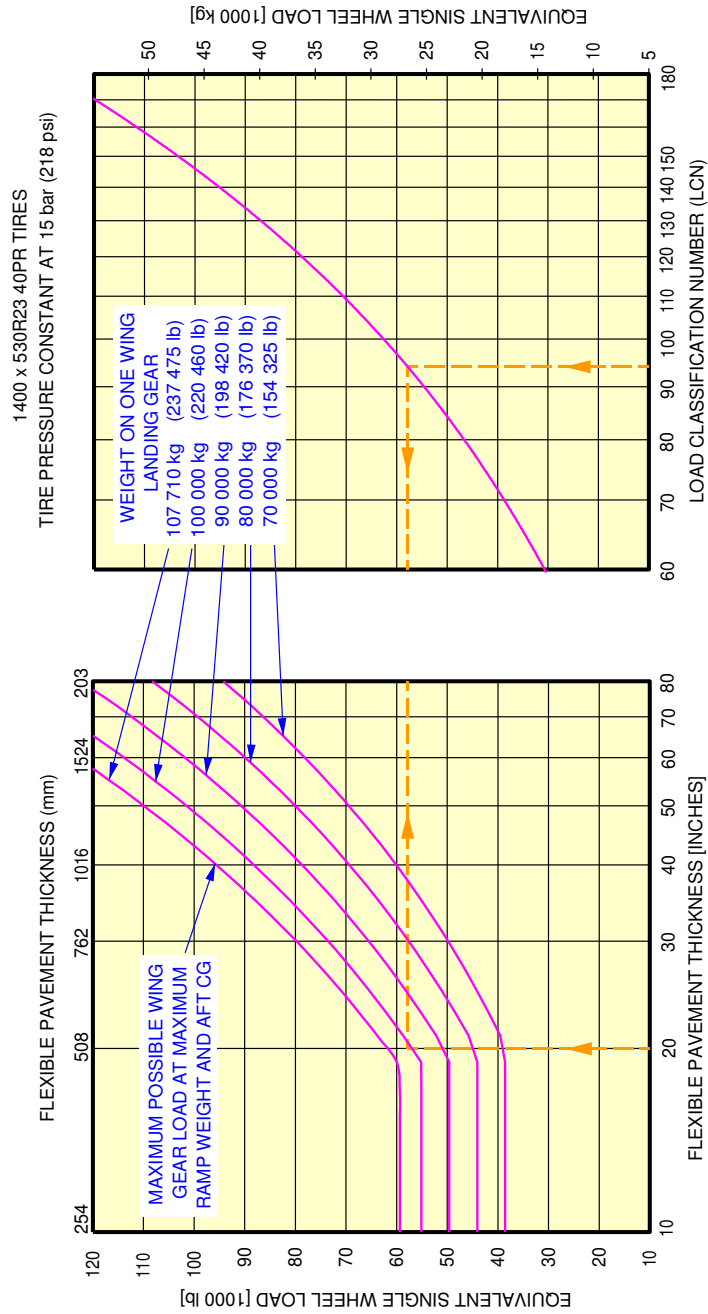

NOTE: EQUIVALENT SINGLE WHEEL LOADS ARE DERIVED BY METHODS SHOWN IN ICAO AERODROME MANUAL PART 2 PAR 4.1.3 Second Edition 1965

L_AC_070601_1_0050101_01_00

Flex Pavement Requirements LCN - 4 Wheel Bogie
MRW 571 000 kg - A380-800 Models

**ON A/C A380-800 Models

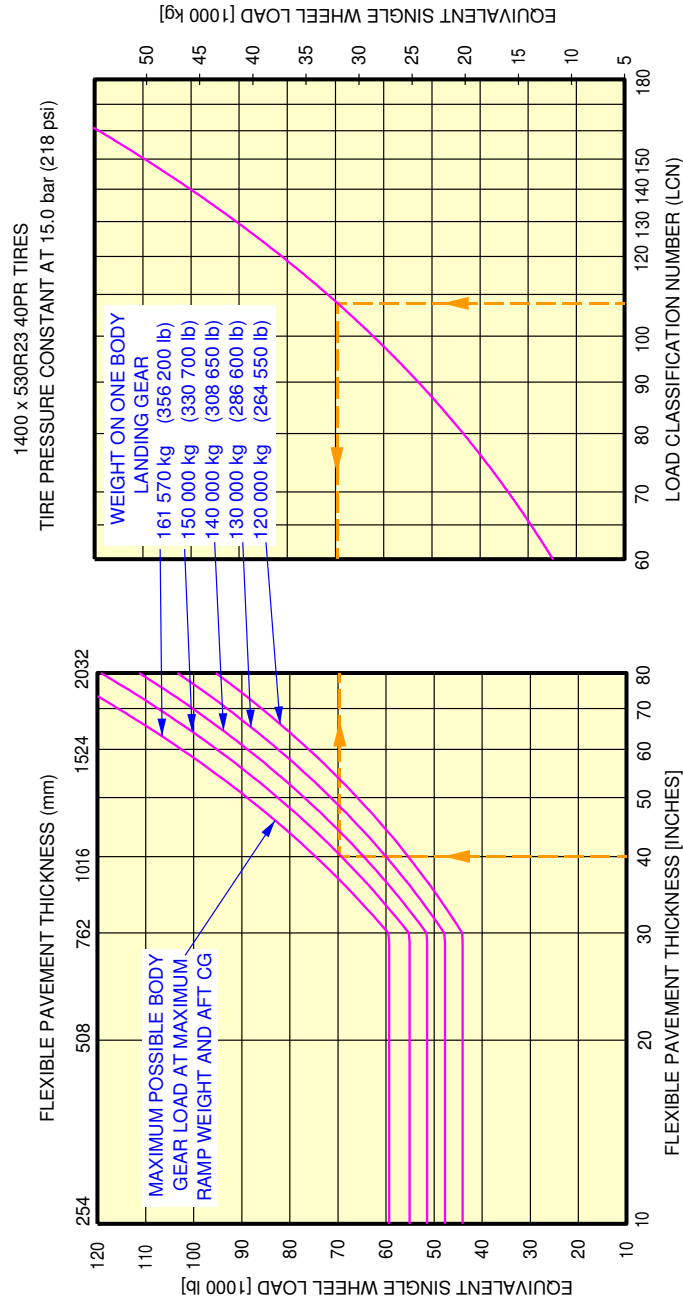

NOTE: EQUIVALENT SINGLE WHEEL LOADS ARE DERIVED BY METHODS SHOWN IN ICAO AERODROME MANUAL PART 2 PAR 4.1.3 Second Edition 1965

L_AC_070601_1_0060101_01_00

Flex Pavement Requirements LCN - 6 Wheel Bogie
MRW 571 000 kg - A380-800 Models



AIRPLANE CHARACTERISTICS

****ON A/C A380-800F Models**

For A380-800F Models Flexible Pavement Requirements - LCN Conversion - Freighter

1. This section gives Flexible Pavement Requirements - LCN Conversion.

****ON A/C A380-800F Models**

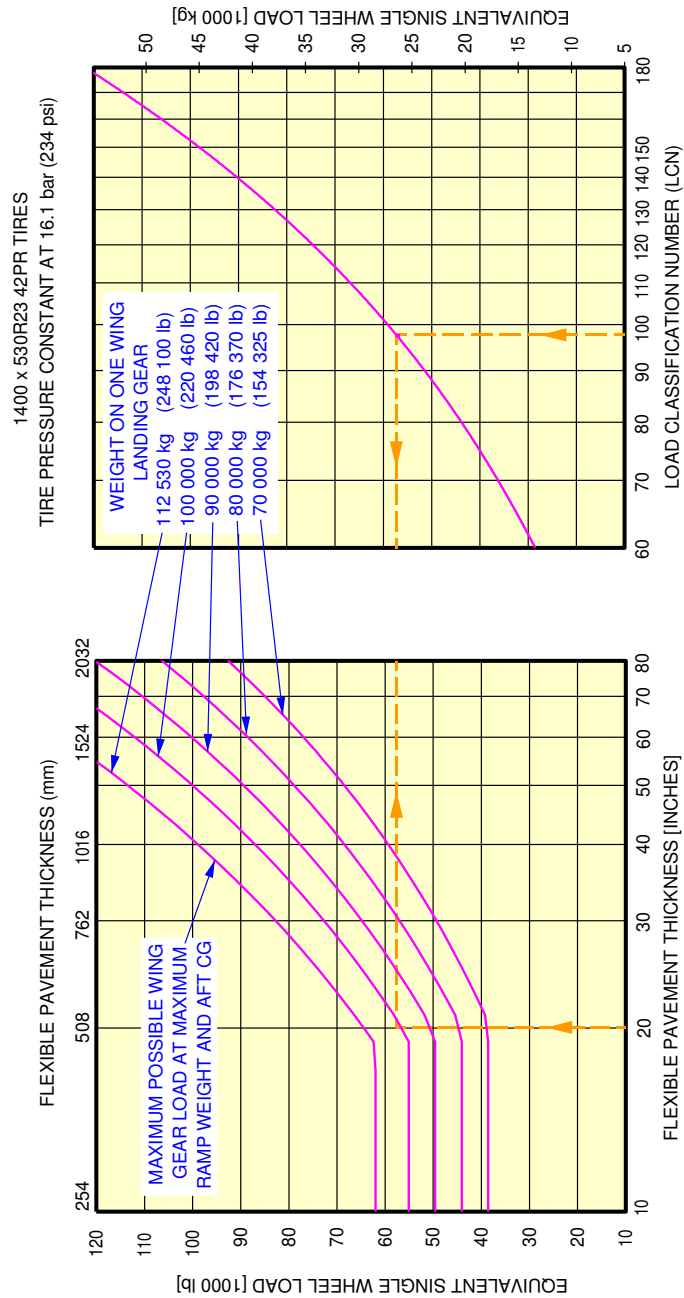

L_AC_070601_1_0030101_01_01

Flex Pavement Requirements LCN - 4 Wheel Bogie
MRW 592 000 kg - A380-800F Models

**ON A/C A380-800F Models

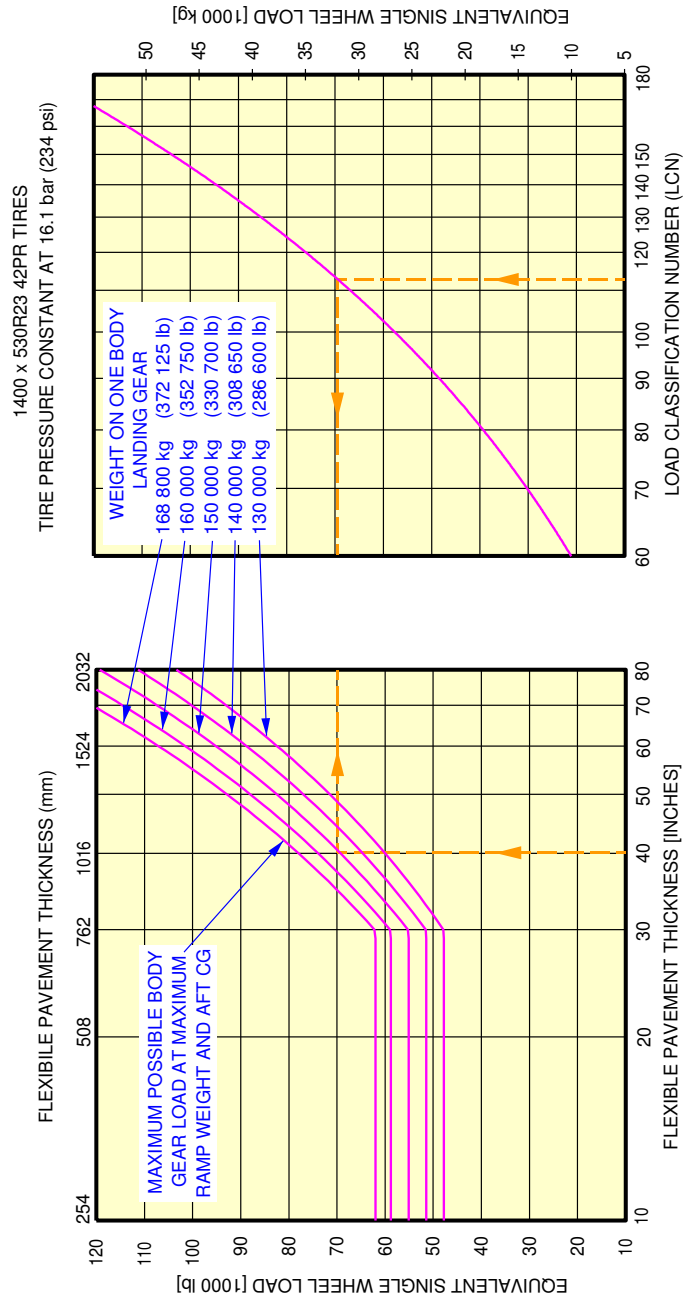

NOTE: EQUIVALENT SINGLE WHEEL LOADS ARE DERIVED BY METHODS SHOWN IN ICAO AERODROME MANUAL PART 2 PAR 4.1.3 Second Edition 1965

L_AC_070601_1_0040101_01_01

Flex Pavement Requirements LCN - 6 Wheel Bogie
MRW 592 000 kg - A380-800F Models

****ON A/C A380-800F Models**

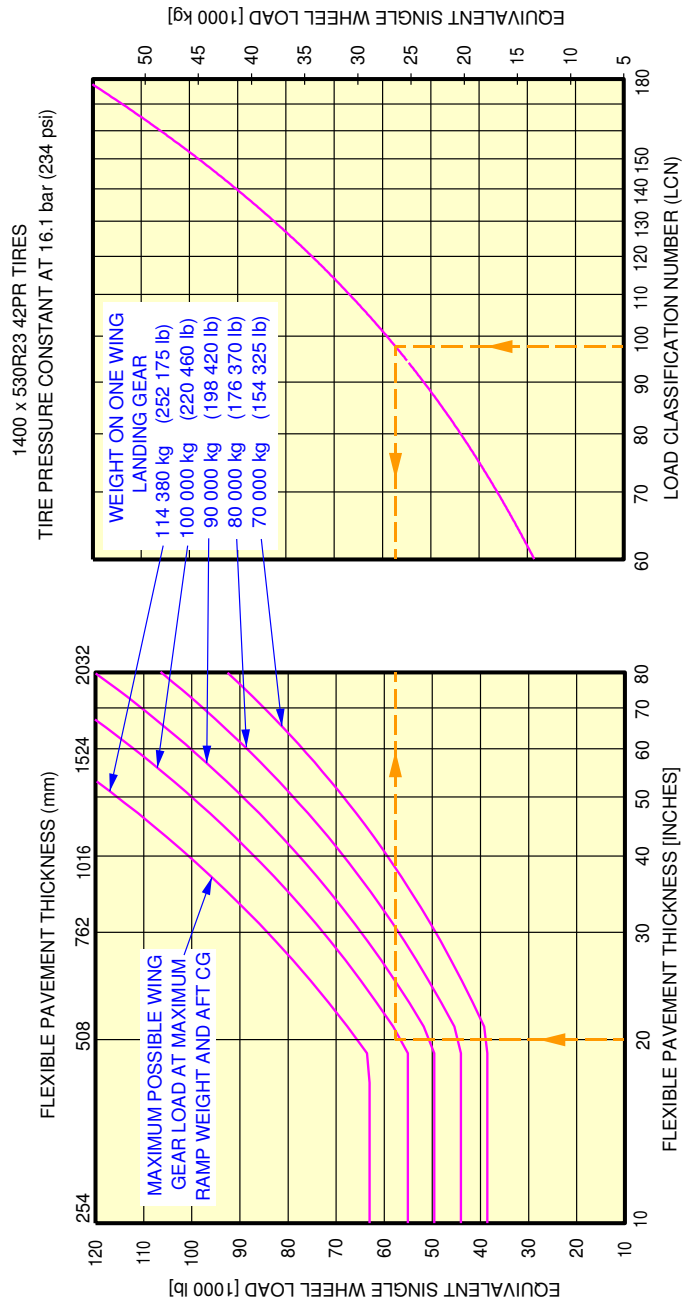

NOTE: EQUIVALENT SINGLE WHEEL LOADS ARE DERIVED BY METHODS SHOWN IN ICAO AERODROME MANUAL PART 2 PAR 4.1.3 Second Edition 1965

L_AC_070601_1_0070101_01_00

Flex Pavement Requirements LCN - 4 Wheel Bogie
MRW 602 000 kg - A380-800F Models

**ON A/C A380-800F Models

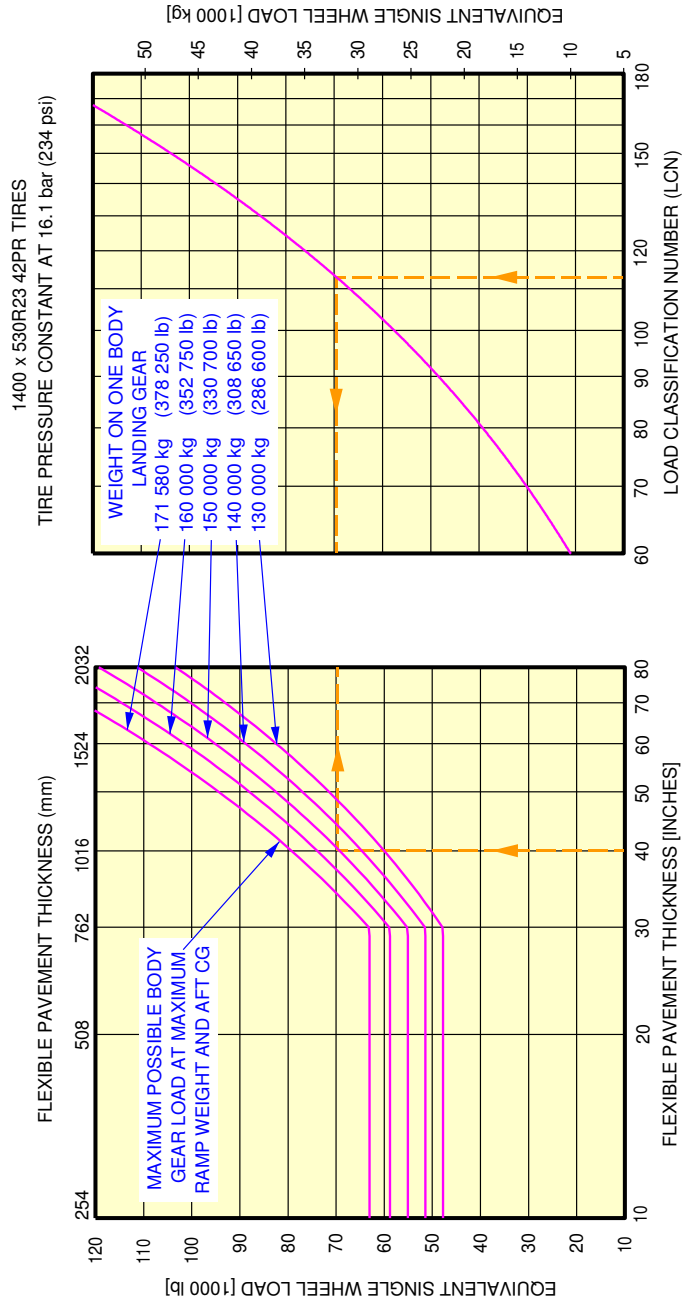

L_AC_070601_1_0080101_01_00

Flex Pavement Requirements LCN - 6 Wheel Bogie
MRW 602 000 kg - A380-800F Models

7-7-0 Rigid Pavement Requirements - Portland Cement Association Design Method

****ON A/C A380-800 Models A380-800F Models**

Rigid Pavement Requirements - Portland Cement Association Design Method

1. General

To determine a Rigid Pavement Thickness, the Subgrade Modulus (k), the allowable working stress and the weight on one Main Landing Gear must be known.

In the typical example shown in Section 7-7-1 with MRW 512000 kg, for:

- a k value of 150 MN/m^3 (550 lb/in^3)
- an allowable working stress of 36 kg/cm^2 (500 lb/in^2)
- the load on one Wing Landing Gear of 90000 kg (198420 lb), the required Rigid Pavement Thickness is 24 cm (9.5 inches).



AIRPLANE CHARACTERISTICS

7-7-1 Rigid Pavement Requirements - Portland Cement Association Design Method

****ON A/C A380-800 Models**

Rigid Pavement Requirements - Portland Cement Association Design Method - Pax

1. This section gives Rigid Pavement Requirements.

**ON A/C A380-800 Models

1400 x 530R23 40PR TIRES
TIRE PRESSURE CONSTANT = 14 BAR (203 PSI)

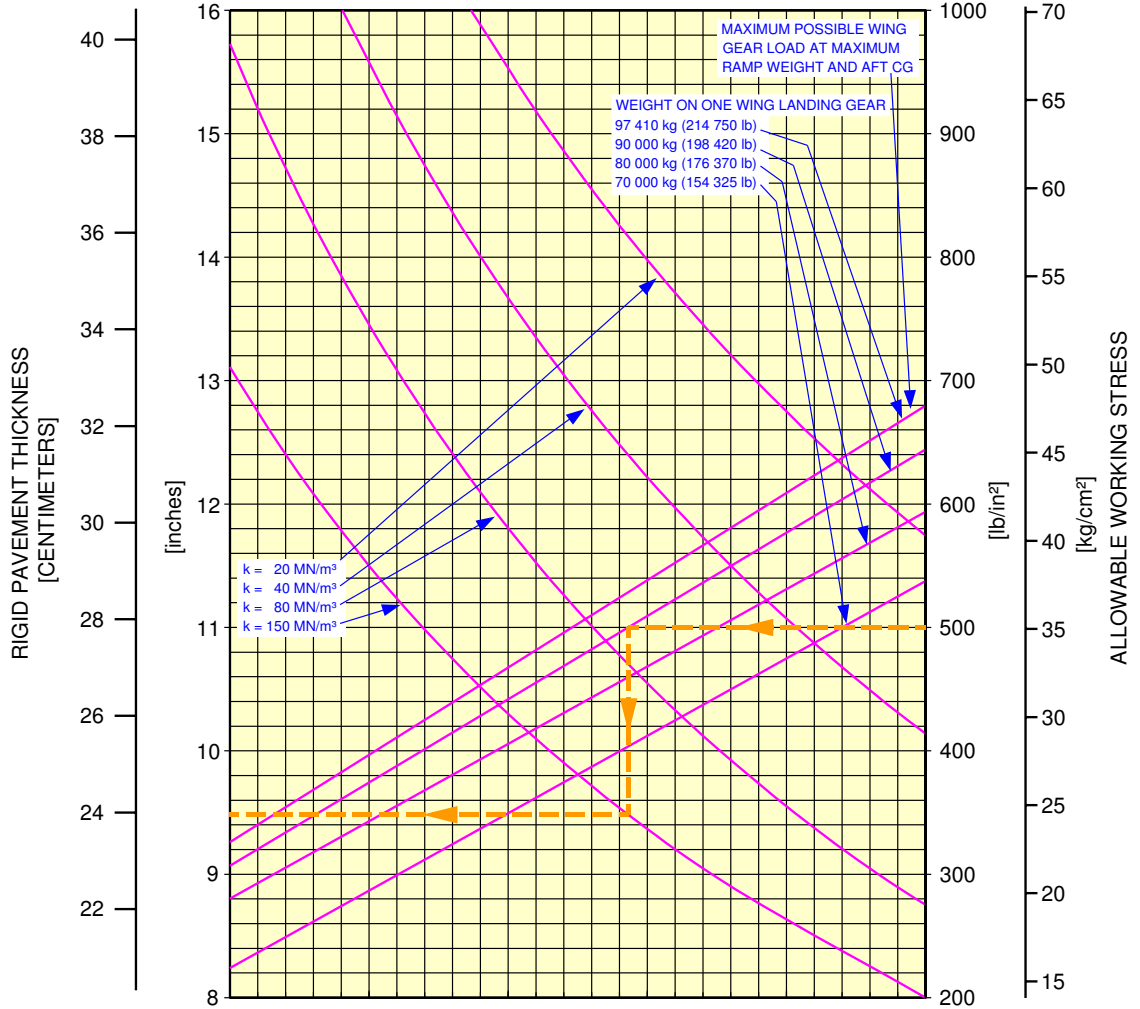

NOTES:
THE VALUES OBTAINED BY USING THE MAXIMUM LOAD REFERENCE LINE AND ANY VALUES FOR K ARE EXACT. FOR LOADS LESS THAN MAXIMUM, THE CURVES ARE EXACT FOR $K = 80 \text{ MN/m}^3$ BUT DEVIATE SLIGHTLY FOR ANY OTHER VALUES OF K

REFERENCE:
"DESIGN OF CONCRETE AIRPORT PAVEMENTS" AND "COMPUTER PROGRAM FOR AIRPORT PAVEMENT DESIGN – PROGRAM PDILB" PORTLAND CEMENT ASSOCIATION

L_AC_070701_1_0090101_01_00

Rigid Pavement Requirements - 4 Wheel Bogie
MRW 512 000 kg - A380-800 Models

**ON A/C A380-800 Models

1400 x 530R23 40PR TIRES
TIRE PRESSURE CONSTANT = 14 BAR (203 PSI)

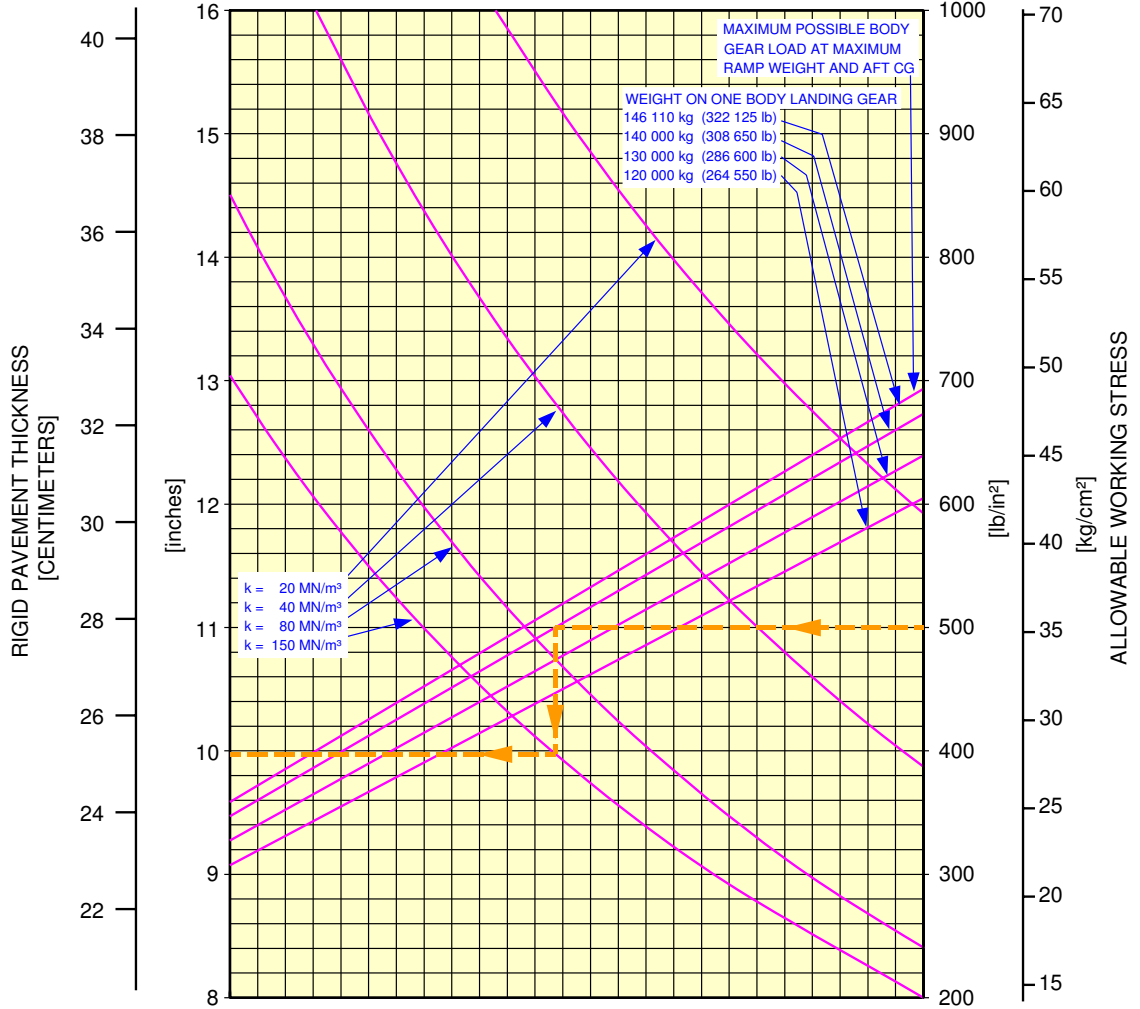

NOTES:
THE VALUES OBTAINED BY USING THE MAXIMUM LOAD REFERENCE LINE AND ANY VALUES FOR K ARE EXACT. FOR LOADS LESS THAN MAXIMUM, THE CURVES ARE EXACT FOR $K = 80 \text{ MN/m}^3$ BUT DEVIATE SLIGHTLY FOR ANY OTHER VALUES OF K

REFERENCE:
"DESIGN OF CONCRETE AIRPORT PAVEMENTS" AND "COMPUTER PROGRAM FOR AIRPORT PAVEMENT DESIGN - PROGRAM PDILB" PORTLAND CEMENT ASSOCIATION

L_AC_070701_1_0100101_01_00

Rigid Pavement Requirements - 6 Wheel Bogie
MRW 512 000 kg - A380-800 Models

****ON A/C A380-800 Models**

1400 x 530R23 40PR TIRES
TIRE PRESSURE CONSTANT = 15 BAR (218 PSI)

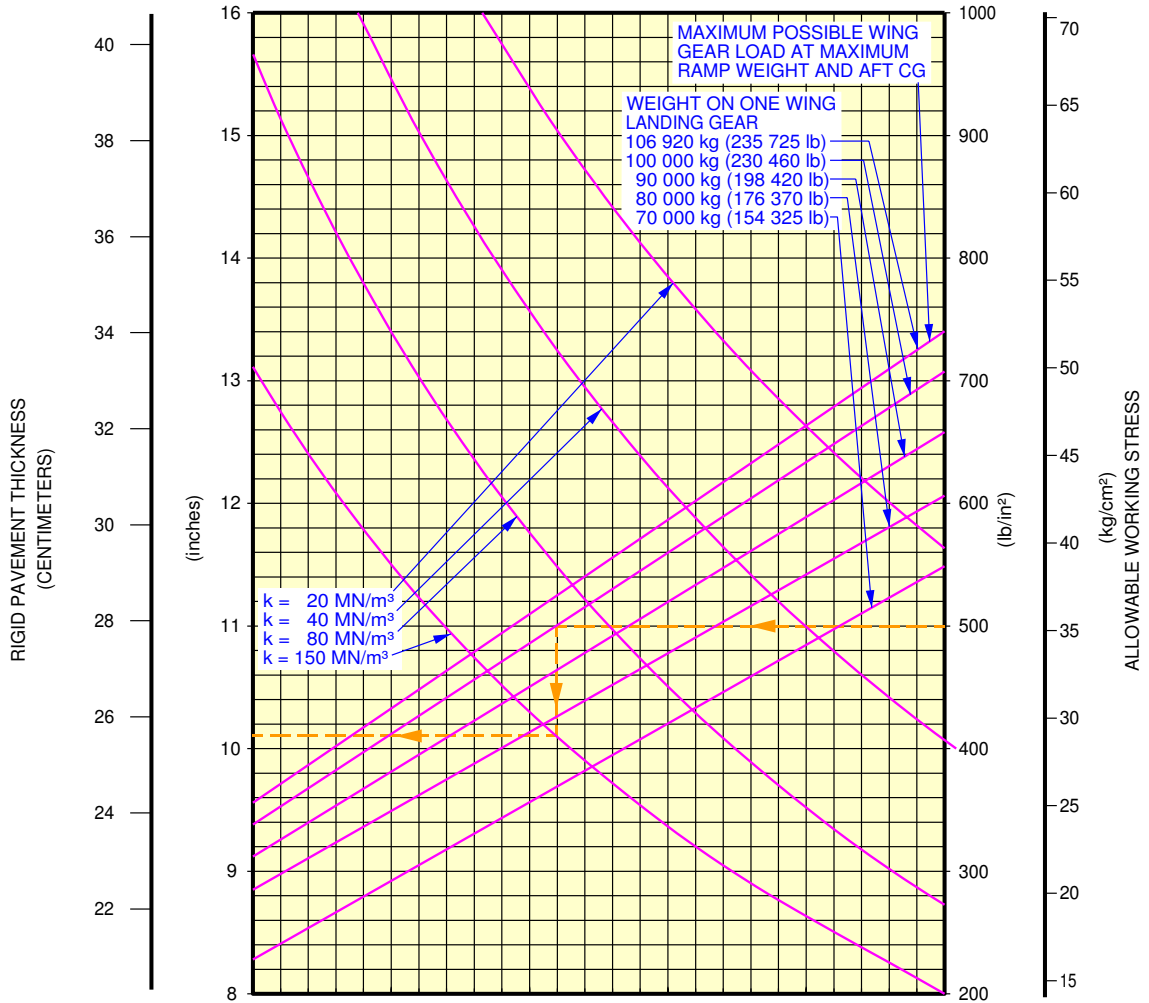

NOTES:
THE VALUES OBTAINED BY USING THE MAXIMUM LOAD REFERENCE LINE AND ANY VALUES FOR K ARE EXACT. FOR LOADS LESS THAN MAXIMUM, THE CURVES ARE EXACT FOR K = 80 MN/m³ BUT DEVIATE SLIGHTLY FOR ANY OTHER VALUES OF K.

REFERENCE:
"DESIGN OF CONCRETE AIRPORT PAVEMENTS" AND "COMPUTER PROGRAM FOR AIRPORT PAVEMENT DESIGN - PROGRAM PDILB" PORTLAND CEMENT ASSOCIATION

L_AC_070701_1_0110101_01_00

Rigid Pavement Requirements - 4 Wheel Bogie
MRW 562 000 kg - A380-800 Models

****ON A/C A380-800 Models**

1400 x 530R23 40PR TIRES
TIRE PRESSURE CONSTANT = 15 BAR (218 PSI)

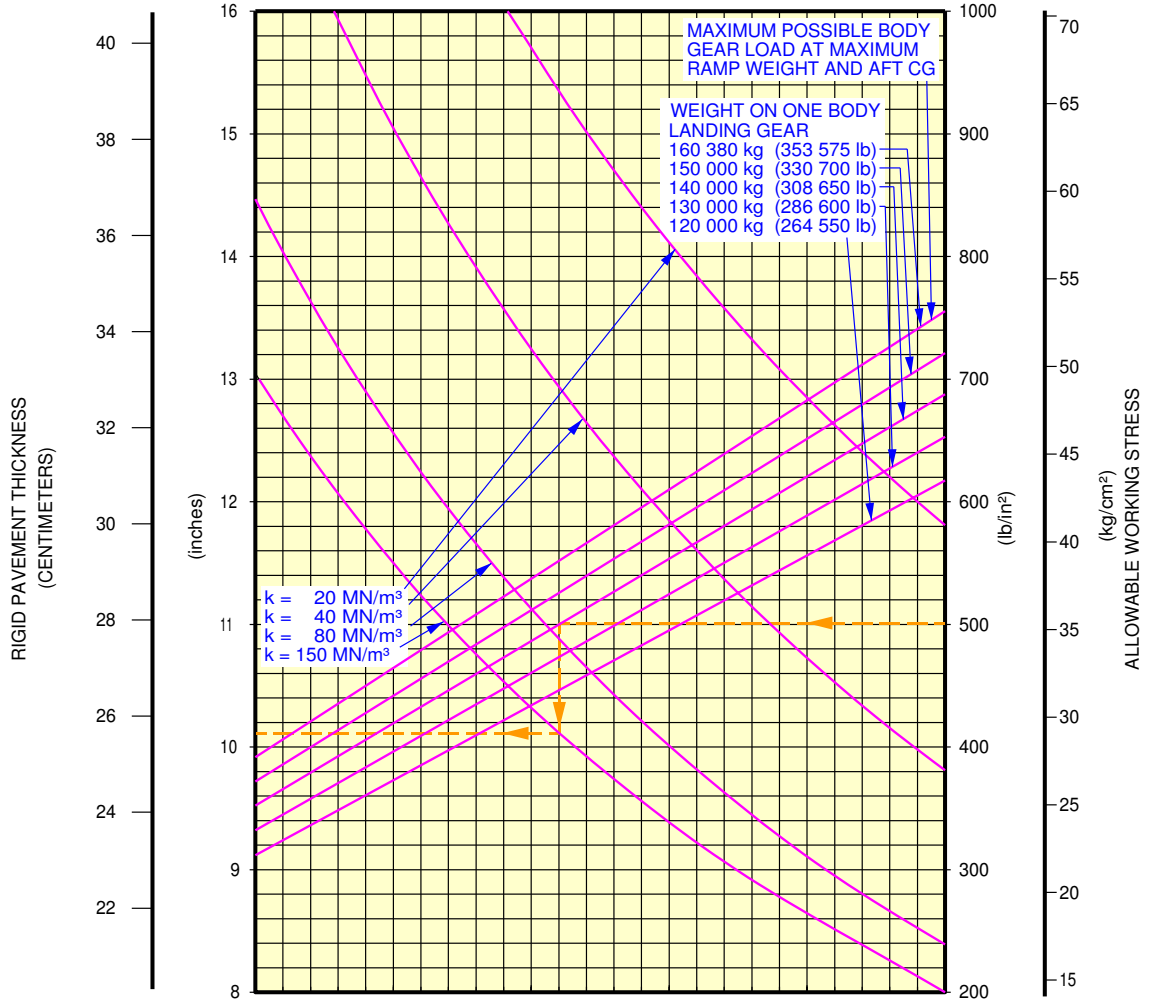

NOTES:
THE VALUES OBTAINED BY USING THE MAXIMUM LOAD REFERENCE LINE AND ANY VALUES FOR K ARE EXACT. FOR LOADS LESS THAN MAXIMUM, THE CURVES ARE EXACT FOR K = 80 MN/m³ BUT DEVIATE SLIGHTLY FOR ANY OTHER VALUES OF K

REFERENCE:
"DESIGN OF CONCRETE AIRPORT PAVEMENTS" AND "COMPUTER PROGRAM FOR AIRPORT PAVEMENT DESIGN - PROGRAM PDILB" PORTLAND CEMENT ASSOCIATION

L_AC_070701_1_0020101_01_01

Rigid Pavement Requirements - 6 Wheel Bogie
MRW 562 000 kg - A380-800 Models

****ON A/C A380-800 Models**

1400 x 530R23 40PR TIRES
TIRE PRESSURE CONSTANT = 15 BAR (218 PSI)

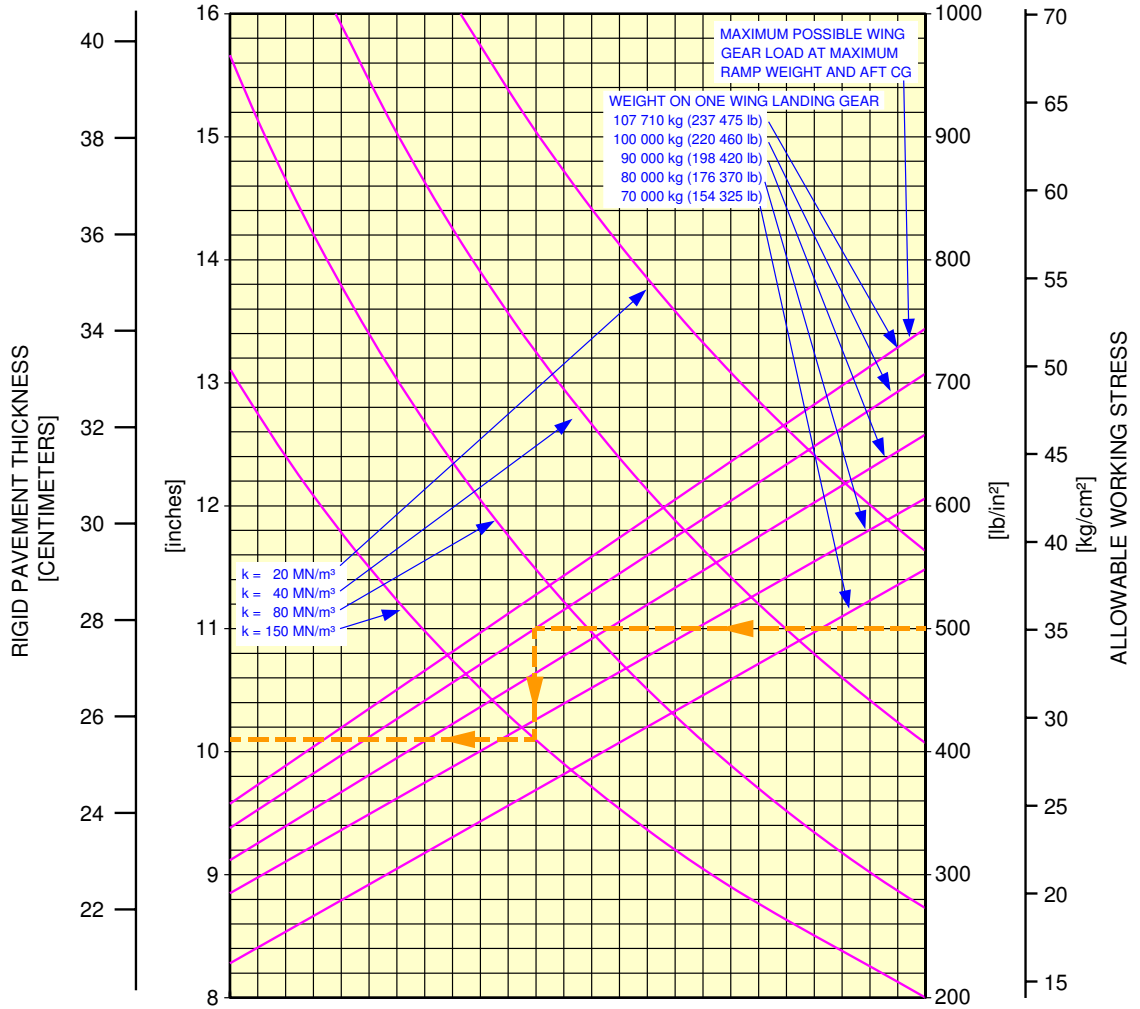

NOTES:
THE VALUES OBTAINED BY USING THE MAXIMUM LOAD REFERENCE LINE AND ANY VALUES FOR K ARE EXACT. FOR LOADS LESS THAN MAXIMUM, THE CURVES ARE EXACT FOR $K = 80 \text{ MN/m}^3$ BUT DEVIATE SLIGHTLY FOR ANY OTHER VALUES OF K

REFERENCE:
"DESIGN OF CONCRETE AIRPORT PAVEMENTS" AND "COMPUTER PROGRAM FOR AIRPORT PAVEMENT DESIGN - PROGRAM PDILB" PORTLAND CEMENT ASSOCIATION

L_AC_070701_1_0120101_01_00

Rigid Pavement Requirements - 4 Wheel Bogie
MRW 571 000 kg - A380-800 Models

****ON A/C A380-800 Models**

1400 x 530R23 40PR TIRES
TIRE PRESSURE CONSTANT = 15 BAR (218 PSI)

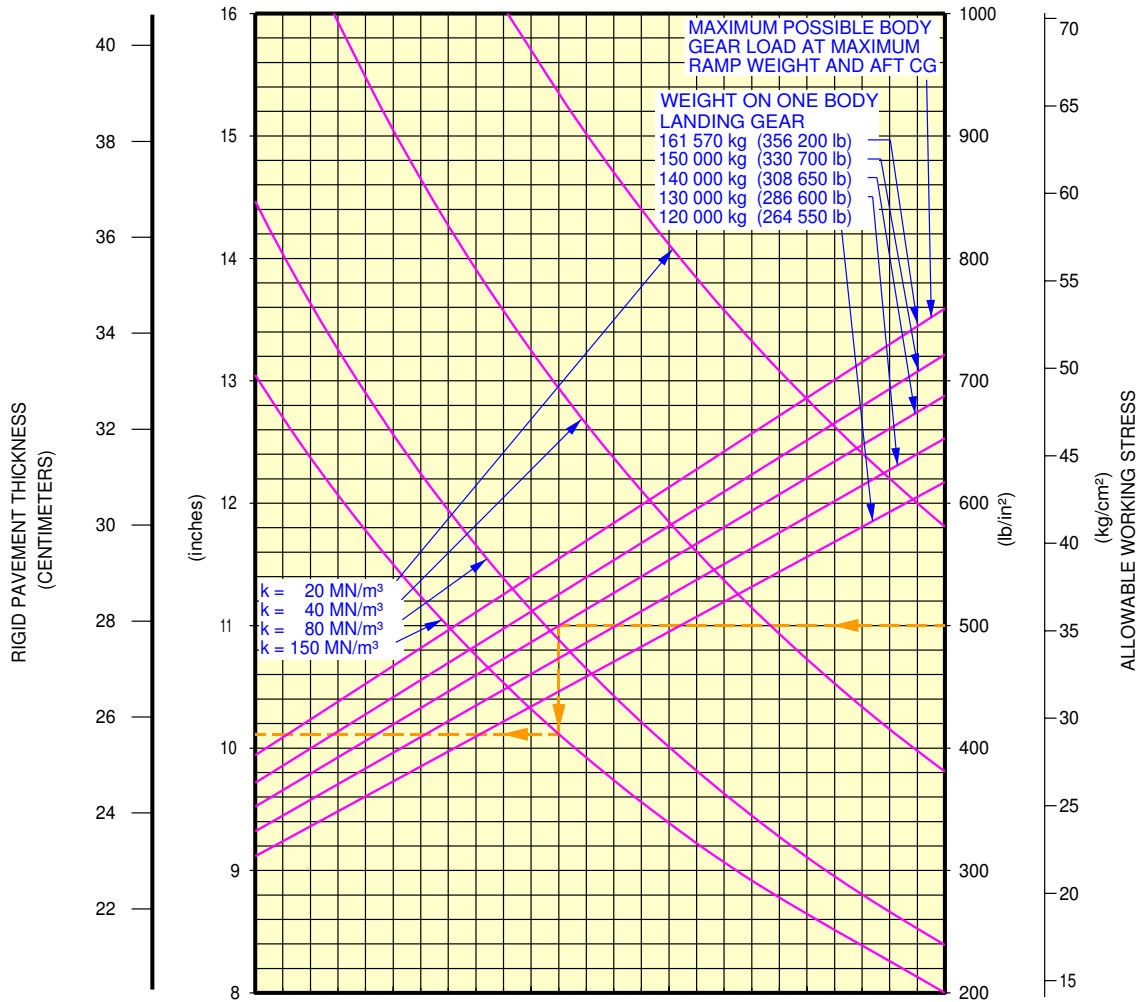

L_AC_070701_1_0060101_01_00

Rigid Pavement Requirements - 6 Wheel Bogie
MRW 571 000 kg - A380-800 Models



AIRPLANE CHARACTERISTICS

****ON A/C A380-800F Models**

Rigid Pavement Requirements - Portland Cement Association Design Method - Freighter

1. This section gives Rigid Pavement Requirements.

****ON A/C A380-800F Models**

1400 x 530R23 42PR TIRES
TIRE PRESSURE CONSTANT = 16.1 BAR (234 PSI)

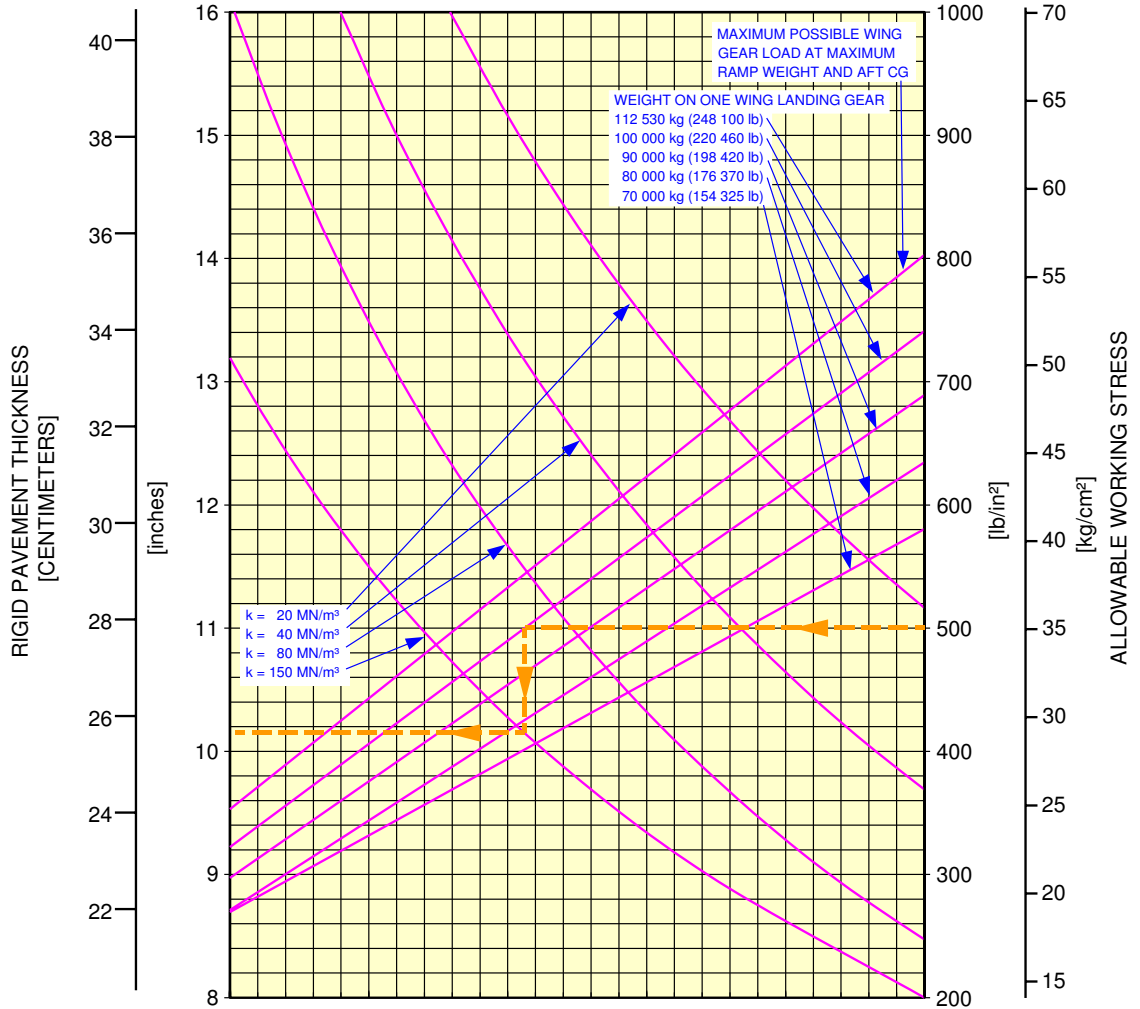

NOTES:
THE VALUES OBTAINED BY USING THE MAXIMUM LOAD REFERENCE LINE AND ANY VALUES FOR K ARE EXACT. FOR LOADS LESS THAN MAXIMUM, THE CURVES ARE EXACT FOR K = 80 MN/m³ BUT DEVIATE SLIGHTLY FOR ANY OTHER VALUES OF K

REFERENCE:
"DESIGN OF CONCRETE AIRPORT PAVEMENTS" AND "COMPUTER PROGRAM FOR AIRPORT PAVEMENT DESIGN - PROGRAM PDILB" PORTLAND CEMENT ASSOCIATION

L_AC_070701_1_0130101_01_00

Rigid Pavement Requirements - 4 Wheel Bogie
MRW 592 000 kg - A380-800F Models

****ON A/C A380-800F Models**

1400 x 530R23 42PR TIRES
TIRE PRESSURE CONSTANT = 16.1 BAR (234 PSI)

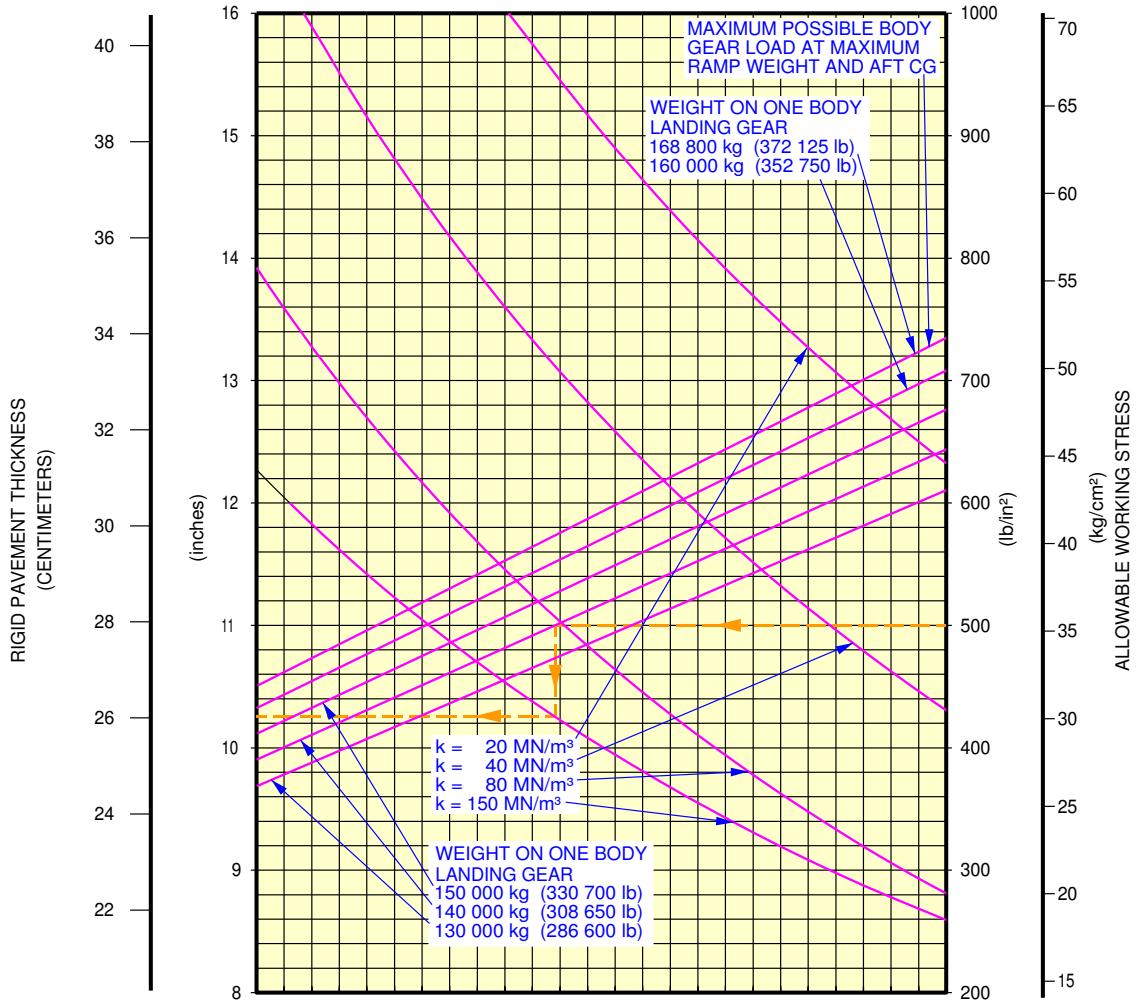

NOTES:
THE VALUES OBTAINED BY USING THE MAXIMUM LOAD REFERENCE LINE AND ANY VALUES FOR K ARE EXACT. FOR LOADS LESS THAN MAXIMUM, THE CURVES ARE EXACT FOR K = 80 MN/m³ BUT DEVIATE SLIGHTLY FOR ANY OTHER VALUES OF K

REFERENCE:
"DESIGN OF CONCRETE AIRPORT PAVEMENTS" AND "COMPUTER PROGRAM FOR AIRPORT PAVEMENT DESIGN - PROGRAM PDILB" PORTLAND CEMENT ASSOCIATION

L_AC_070701_1_0040101_01_01

Rigid Pavement Requirements - 6 Wheel Bogie
MRW 592 000 kg - A380-800F Models

****ON A/C A380-800F Models**

1400 x 530R23 42PR TIRES
TIRE PRESSURE CONSTANT = 16.1 BAR (234 PSI)

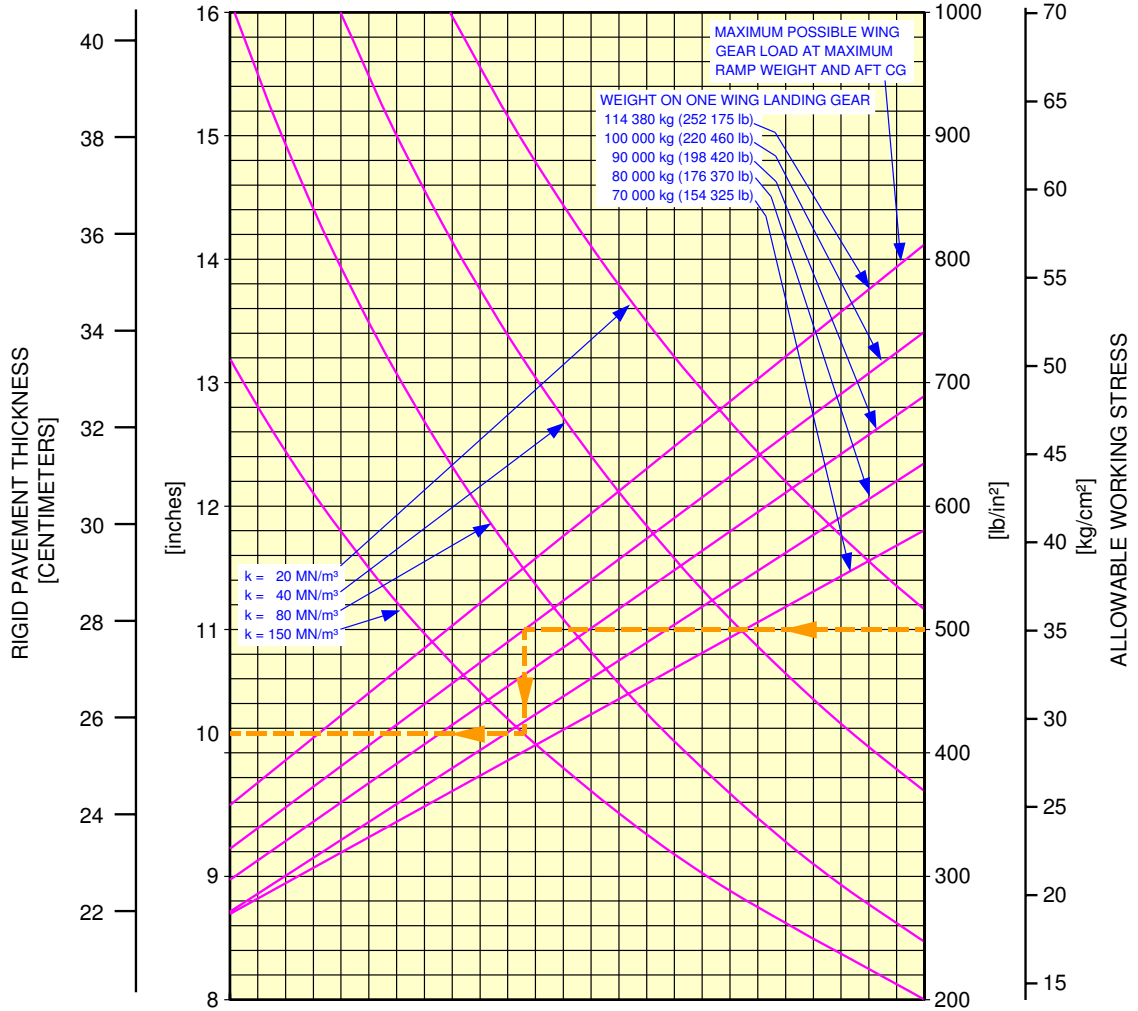

NOTES:
THE VALUES OBTAINED BY USING THE MAXIMUM LOAD REFERENCE LINE AND ANY VALUES FOR K ARE EXACT. FOR LOADS LESS THAN MAXIMUM, THE CURVES ARE EXACT FOR K = 80 MN/m³ BUT DEVIATE SLIGHTLY FOR ANY OTHER VALUES OF K

REFERENCE:
"DESIGN OF CONCRETE AIRPORT PAVEMENTS" AND "COMPUTER PROGRAM FOR AIRPORT PAVEMENT DESIGN - PROGRAM PDILB" PORTLAND CEMENT ASSOCIATION

L_AC_070701_1_0140101_01_00

Rigid Pavement Requirements - 4 Wheel Bogie
MRW 602 000 kg - A380-800F Models

****ON A/C A380-800F Models**

1400 x 530R23 42PR TIRES
TIRE PRESSURE CONSTANT = 16.1 BAR (234 PSI)

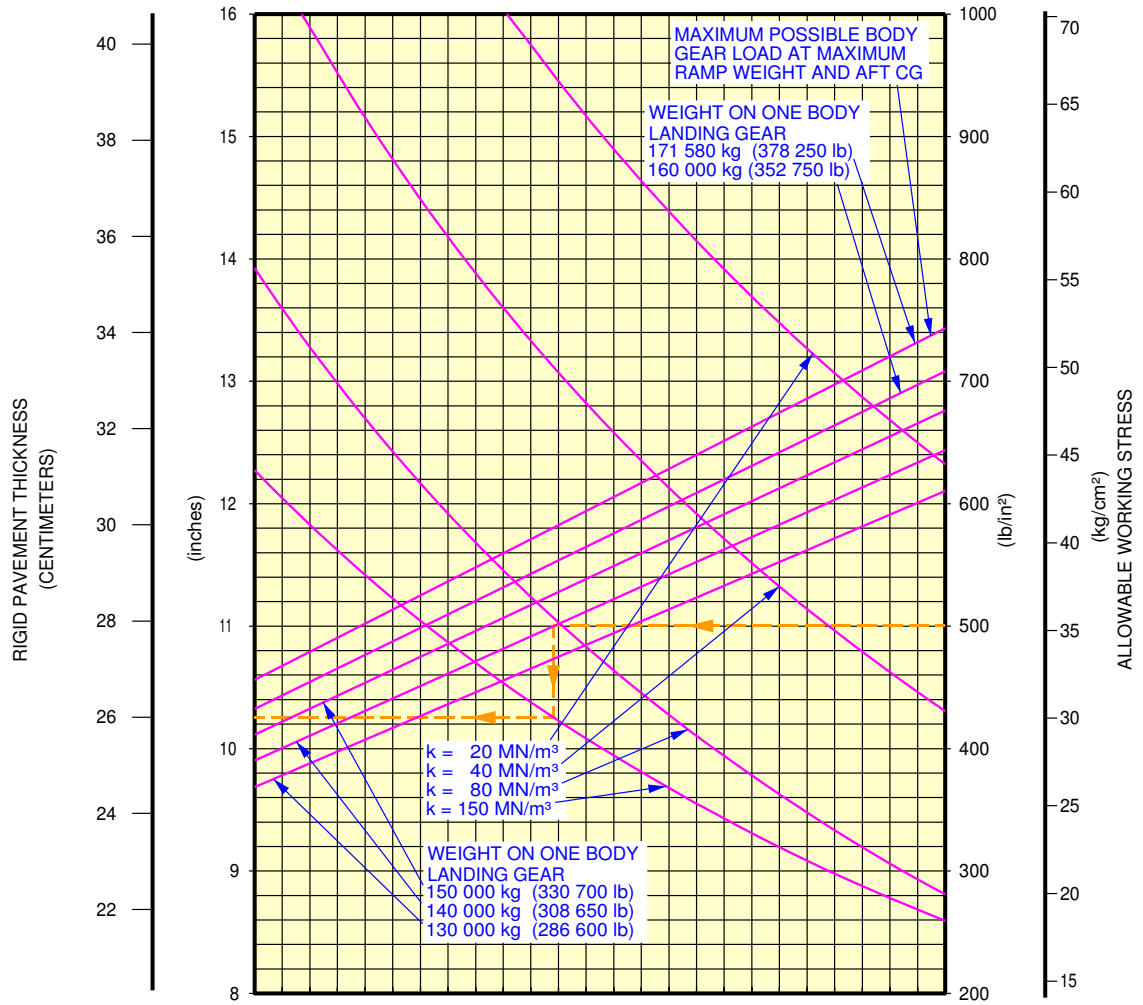

NOTES:
THE VALUES OBTAINED BY USING THE MAXIMUM LOAD REFERENCE LINE AND ANY VALUES FOR K ARE EXACT. FOR LOADS LESS THAN MAXIMUM, THE CURVES ARE EXACT FOR K = 80 MN/m³ BUT DEVIATE SLIGHTLY FOR ANY OTHER VALUES OF K

REFERENCE:
"DESIGN OF CONCRETE AIRPORT PAVEMENTS" AND "COMPUTER PROGRAM FOR AIRPORT PAVEMENT DESIGN - PROGRAM PDILB" PORTLAND CEMENT ASSOCIATION

L_AC_070701_1_0080101_01_00

Rigid Pavement Requirements - 6 Wheel Bogie
MRW 602 000 kg - A380-800F Models

7-8-0 Rigid Pavement Requirements - LCN Conversion

****ON A/C A380-800 Models A380-800F Models**

Rigid Pavement Requirements - LCN Conversion

1. General

To find the airplane weight that a Rigid Pavement can support, the LCN of the pavement and the Radius of Relative Stiffness (L) must be Known.

In the typical example shown in Section 7-8-2 with MRW 512000 Kg, The Radius of Relative Stiffness is shown at 1016 mm (40 in.) with an LCN of 90. For these conditions the weight on one Wing Landing Gear is 90000 kg (198420 lb).



AIRPLANE CHARACTERISTICS

7-8-1 Radius of Relative Stiffness

****ON A/C A380-800 Models A380-800F Models**

Radius of Relative Stiffness

1. This section gives Radius of Relative Stiffness.



AIRPLANE CHARACTERISTICS

****ON A/C A380-800 Models A380-800F Models**

RADIUS OF RELATIVE STIFFNESS (L)
VALUES IN INCHES

$$L = 4 \sqrt{\frac{Ed^3}{12(1-\mu^2)k}} = 24.1652 \sqrt[4]{\frac{d^3}{k}}$$

- WHERE E = Young's Modulus = 4×10^6 psi
 k = Subgrade Modulus, lbf/in³
 d = Rigid Pavement Thickness, inches
 μ = Poisson's Ratio = 0.15

d	k=75	k=100	k=150	k=200	k=250	k=300	k=350	k=400	k=550
6.0	31.48	29.30	26.47	24.63	23.30	22.26	21.42	20.72	19.13
6.5	33.43	31.11	28.11	26.16	24.74	23.64	22.74	22.00	20.31
7.0	35.34	32.89	29.72	27.65	26.15	24.99	24.04	23.25	21.47
7.5	37.22	34.63	31.29	29.12	27.54	26.32	25.32	24.49	22.61
8.0	39.06	36.35	32.85	30.57	28.91	27.62	26.58	25.70	23.74
8.5	40.88	38.04	34.37	31.99	30.25	28.91	27.81	26.90	24.84
9.0	42.67	39.71	35.88	33.39	31.58	30.17	29.03	28.08	25.93
9.5	44.43	41.35	37.36	34.77	32.89	31.42	30.23	29.24	27.00
10.0	46.18	42.97	38.83	36.14	34.17	32.65	31.42	30.39	28.06
10.5	47.90	44.57	40.28	37.48	35.45	33.87	32.59	31.52	29.11
11.0	49.60	46.16	41.71	38.81	36.71	35.07	33.75	32.64	30.14
11.5	51.28	47.72	43.12	40.13	37.95	36.26	34.89	33.74	31.16
12.0	52.94	49.27	44.52	41.43	39.18	37.44	36.02	34.84	32.17
12.5	54.59	50.80	45.90	42.72	40.40	38.60	37.14	35.92	33.17
13.0	56.22	52.32	47.27	43.99	41.61	39.75	38.25	36.99	34.16
13.5	57.83	53.82	48.63	45.26	42.80	40.89	39.35	38.06	35.14
14.0	59.43	55.31	49.98	46.51	43.98	42.02	40.44	39.11	36.12
14.5	61.02	56.78	51.31	47.75	45.16	43.15	41.51	40.15	37.08
15.0	62.59	58.25	52.63	48.98	46.32	44.26	42.58	41.19	38.03
15.5	64.15	59.70	53.94	50.20	47.47	45.36	43.64	42.21	38.98
16.0	65.69	61.13	55.24	51.41	48.62	46.45	44.70	43.23	39.92
16.5	67.23	62.56	56.53	52.61	49.75	47.54	45.74	44.24	40.85
17.0	68.75	63.98	57.81	53.80	50.88	48.61	46.77	45.24	41.78
17.5	70.26	65.38	59.08	54.98	52.00	49.68	47.80	46.23	42.70
18.0	71.76	66.78	60.34	56.15	53.11	50.74	48.82	47.22	43.61
19.0	74.73	69.54	62.84	58.48	55.31	52.84	50.84	49.17	45.41
20.0	77.66	72.27	65.30	60.77	57.47	54.91	52.84	51.10	47.19
21.0	80.55	74.96	67.74	63.04	59.62	56.96	54.81	53.01	48.95
22.0	83.41	77.63	70.14	65.28	61.73	58.98	56.75	54.89	50.69
23.0	86.24	80.26	72.52	67.49	63.83	60.98	58.68	56.75	52.41
24.0	89.04	82.86	74.87	69.68	65.90	62.96	60.58	58.59	54.11
25.0	91.81	85.44	77.20	71.84	67.95	64.92	62.46	60.41	55.79

REFERENCE: PORTLAND CEMENT ASSOCIATION

L_AC_070801_1_0010101_01_00

Radius of Relative Stiffness



AIRPLANE CHARACTERISTICS

7-8-2 Rigid Pavement Requirements - LCN Conversion

****ON A/C A380-800 Models**

Rigid Pavement Requirements - LCN Conversion - Pax

1. This section gives Rigid Pavement Requirements - LCN Conversion.

****ON A/C A380-800 Models**

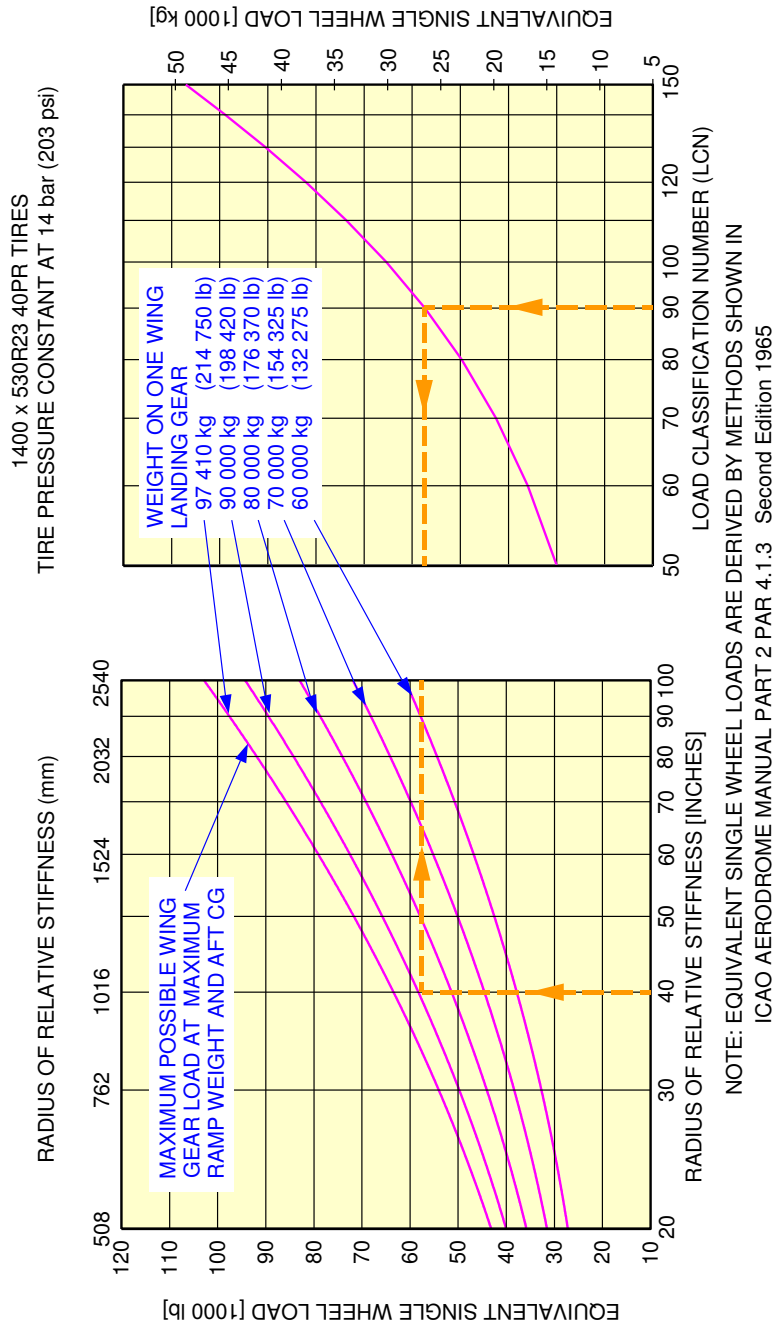

L_AC_070802_1_0090101_01_00

Rigid Pavement Requirements LCN - 4 Wheel Bogie
MRW 512 000 kg - A380-800 Models

****ON A/C A380-800 Models**

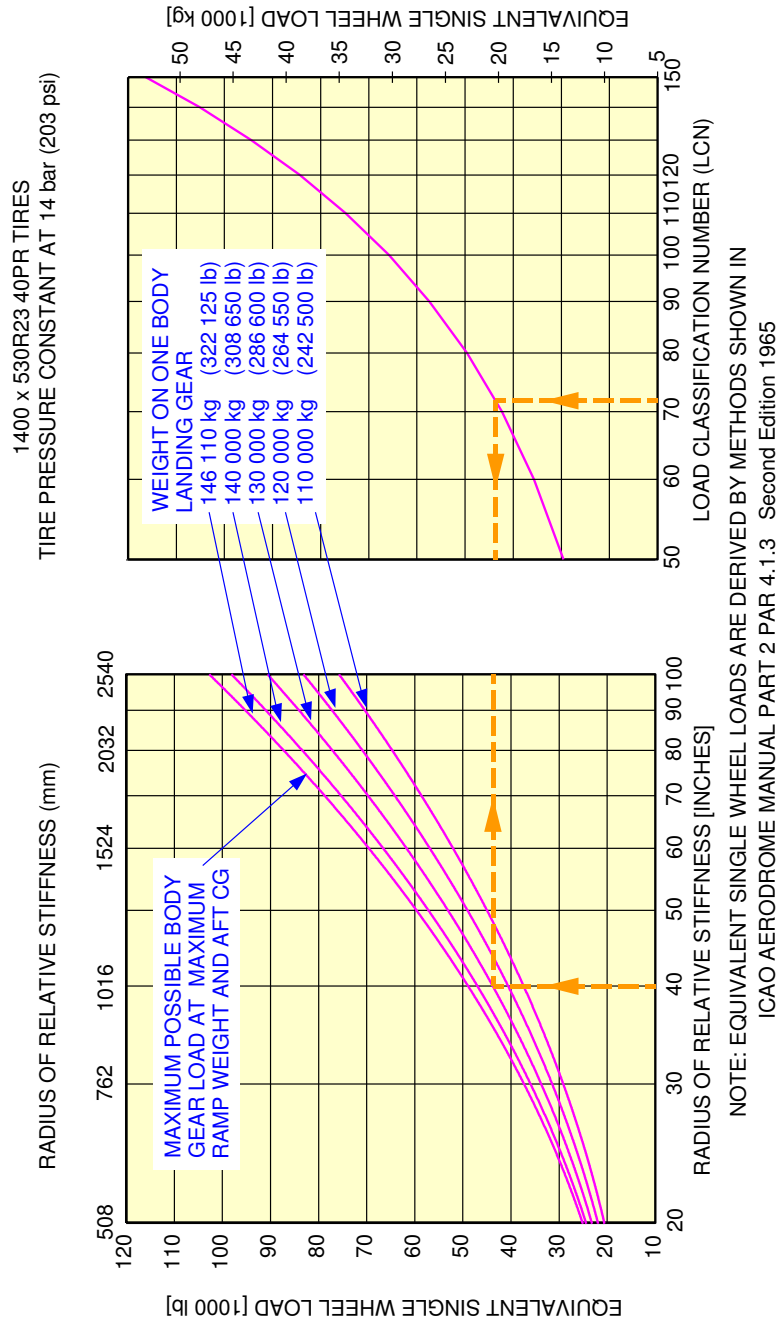

L_AC_070802_1_0100101_01_00

Rigid Pavement Requirements LCN - 6 Wheel Bogie
MRW 512 000 kg - A380-800 Models

****ON A/C A380-800 Models**

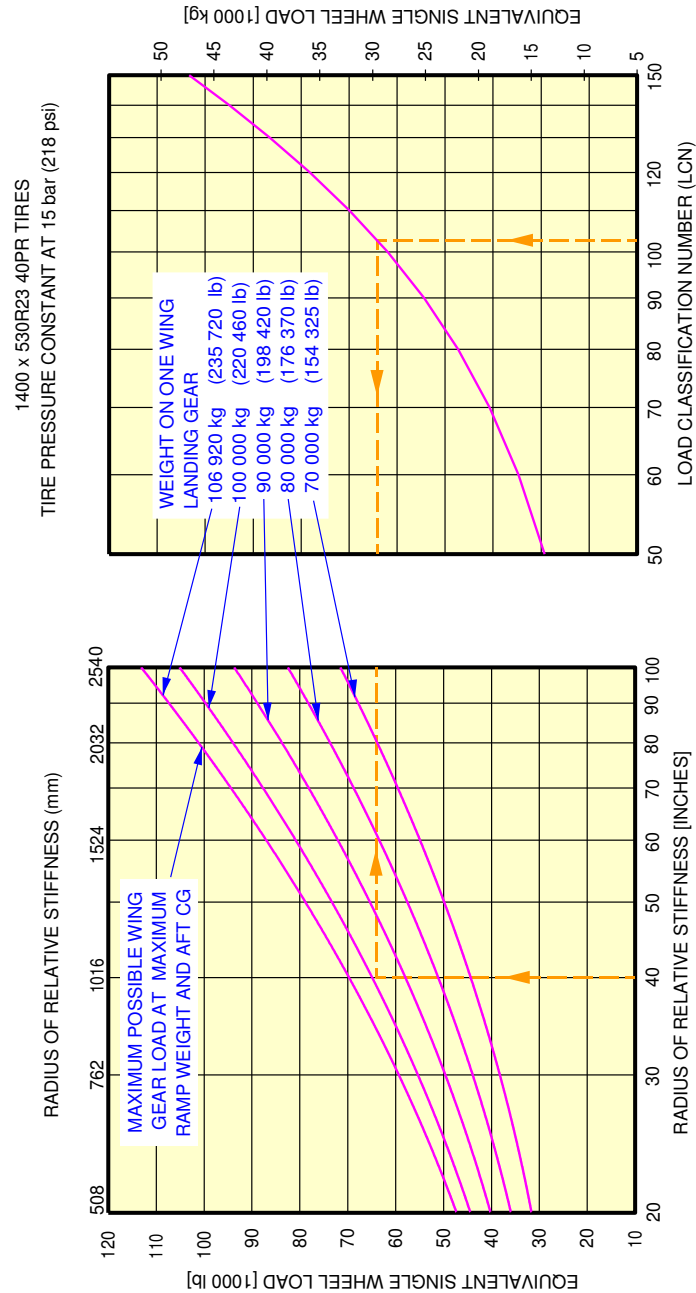

L_AC_070802_1_0010101_01_01

Rigid Pavement Requirements LCN - 4 Wheel Bogie
MRW 562 000 kg - A380-800 Models

****ON A/C A380-800 Models**

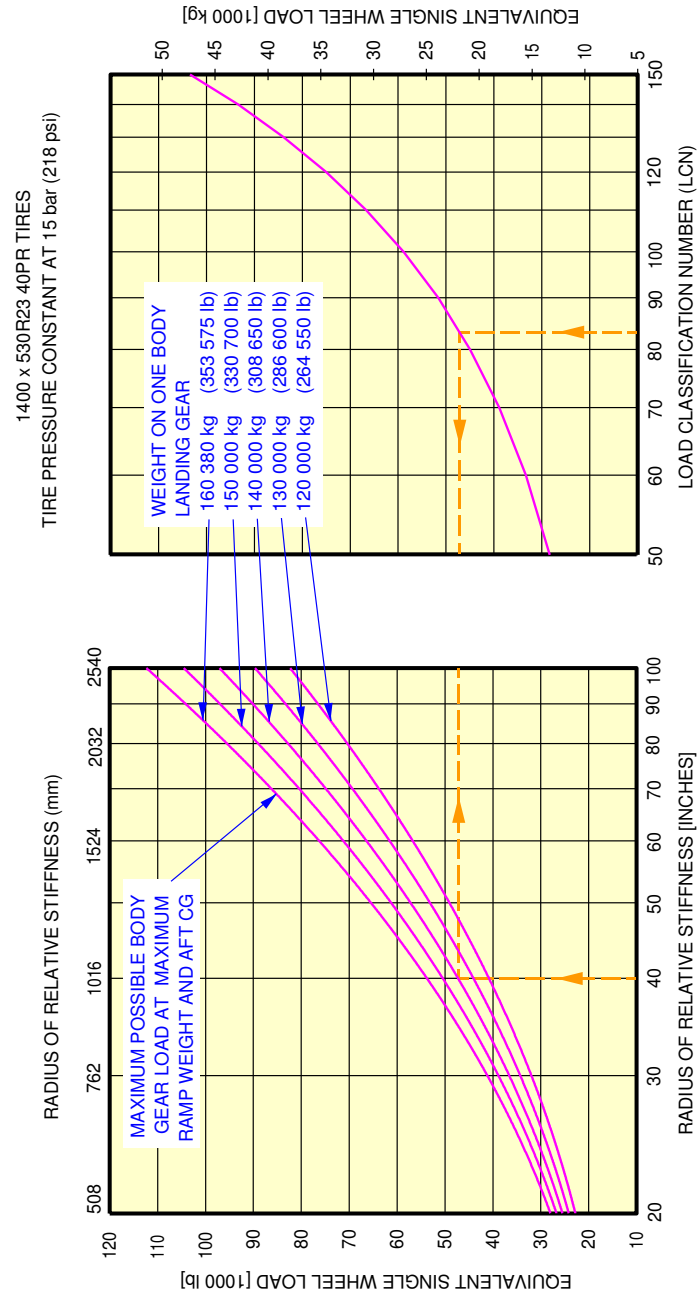

L_AC_070802_1_0020101_01_01

Rigid Pavement Requirements LCN - 6 Wheel Bogie
MRW 562 000 kg - A380-800 Models

****ON A/C A380-800 Models**

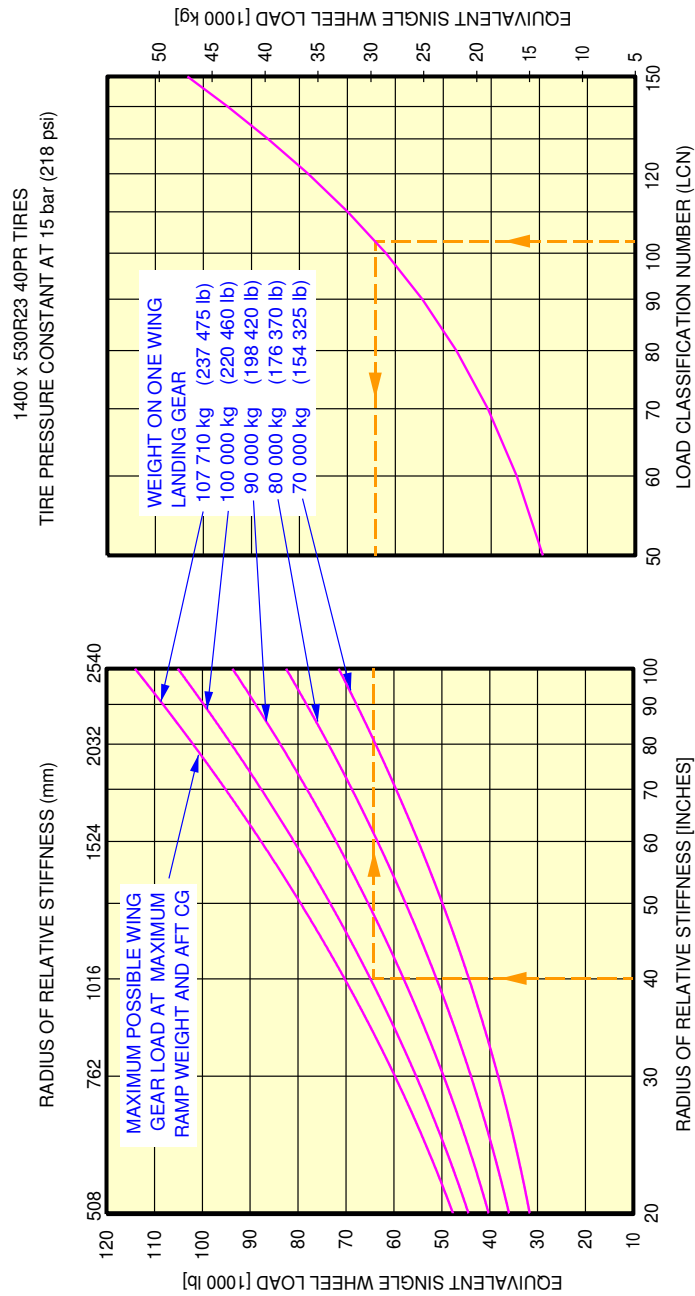

NOTE: EQUIVALENT SINGLE WHEEL LOADS ARE DERIVED BY METHODS SHOWN IN
ICAO AERODROME MANUAL PART 2 PAR 4.1.3 Second Edition 1965

L_AC_070802_1_0050101_01_00

Rigid Pavement Requirements LCN - 4 Wheel Bogie
MRW 571 000 kg - A380-800 Models

****ON A/C A380-800 Models**

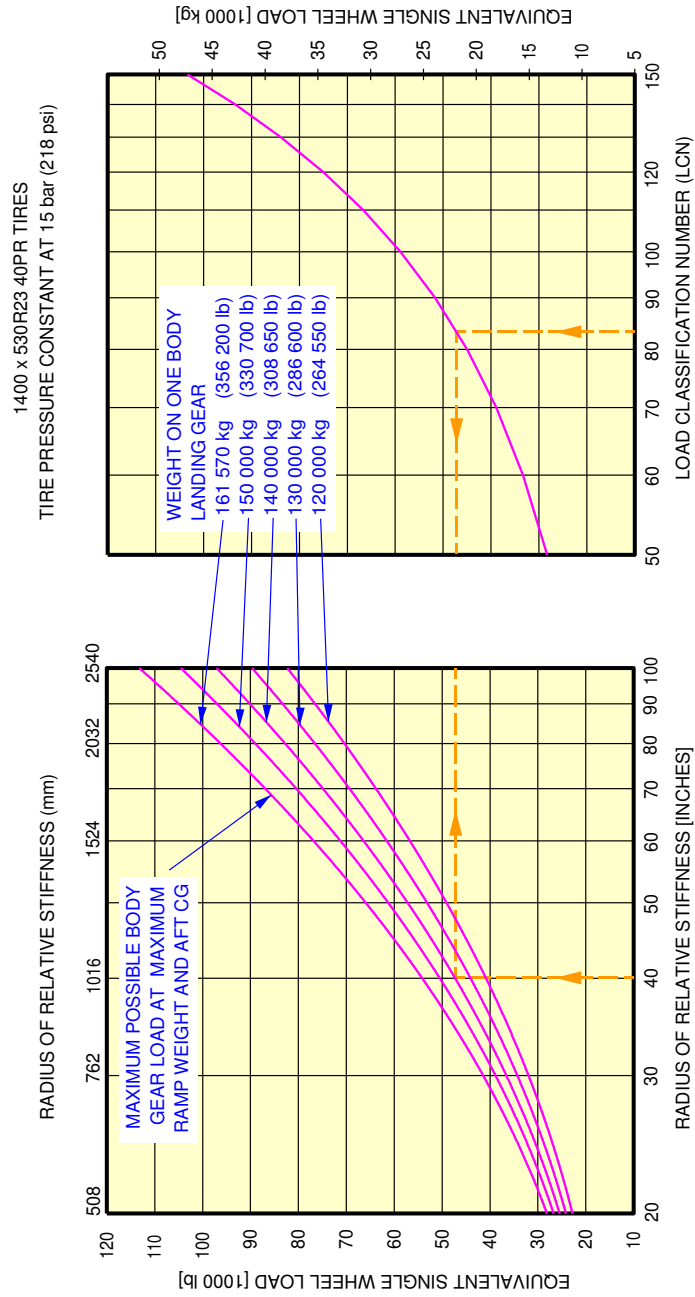

NOTE: EQUIVALENT SINGLE WHEEL LOADS ARE DERIVED BY METHODS SHOWN IN ICAO AERODROME MANUAL PART 2 PAR 4.1.3 Second Edition 1965

L_AC_070802_1_0060101_01_00

Rigid Pavement Requirements LCN - 6 Wheel Bogie
MRW 571 000 kg - A380-800 Models



AIRPLANE CHARACTERISTICS

****ON A/C A380-800F Models**

Rigid Pavement Requirements - LCN Conversion - Freighter

1. This section gives Rigid Pavement Requirements LCN.

****ON A/C A380-800F Models**

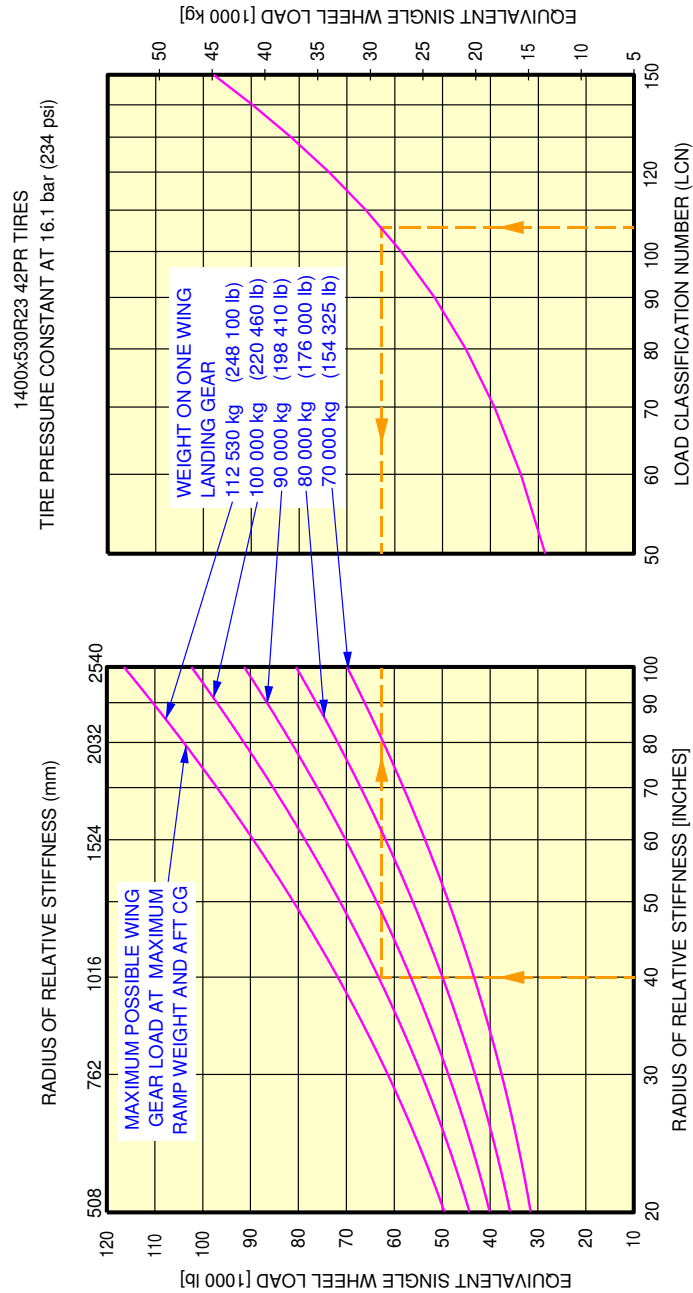

L_AC_070802_1_0030101_01_01

Rigid Pavement Requirements LCN - 4 Wheel Bogie
MRW 592 000 kg - A380-800F Models

****ON A/C A380-800F Models**

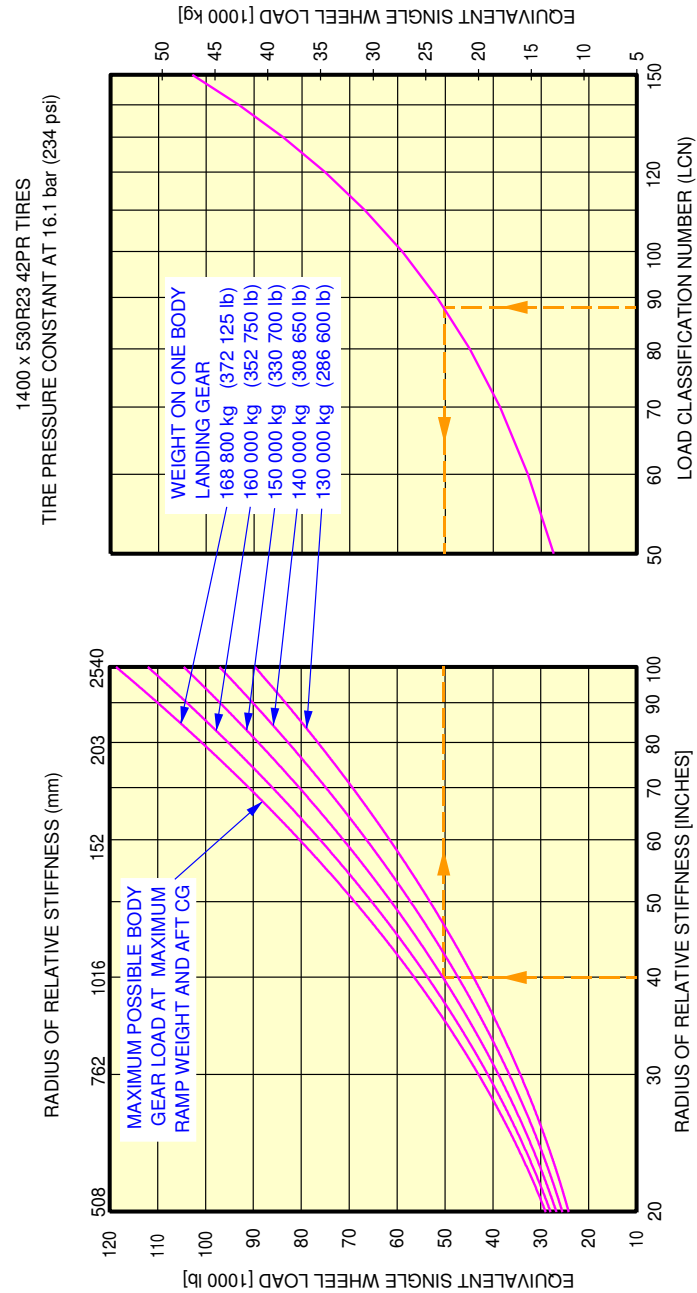

L_AC_070802_1_0040101_01_01

Rigid Pavement Requirements LCN - 6 Wheel Bogie
MRW 592 000 kg - A380-800F Models

****ON A/C A380-800F Models**

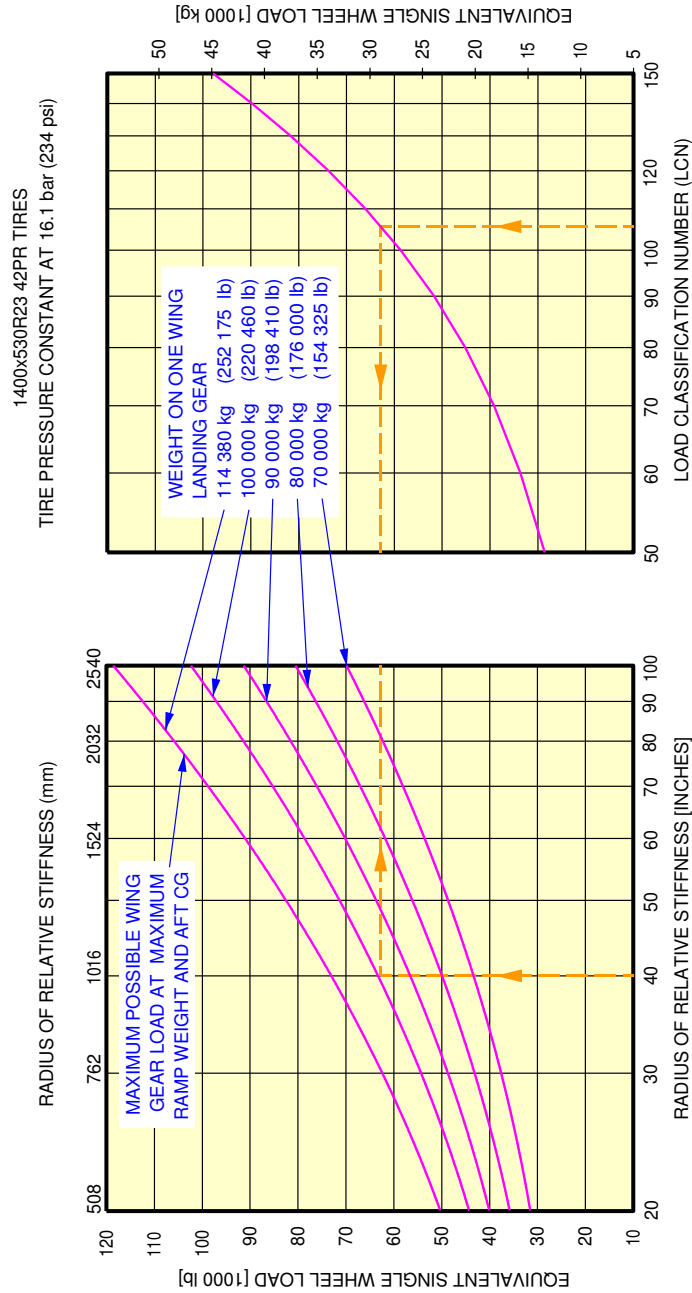

L_AC_070802_1_0070101_01_00

Rigid Pavement Requirements LCN - 4 Wheel Bogie
MRW 602 000 kg - A380-800F Models

****ON A/C A380-800F Models**

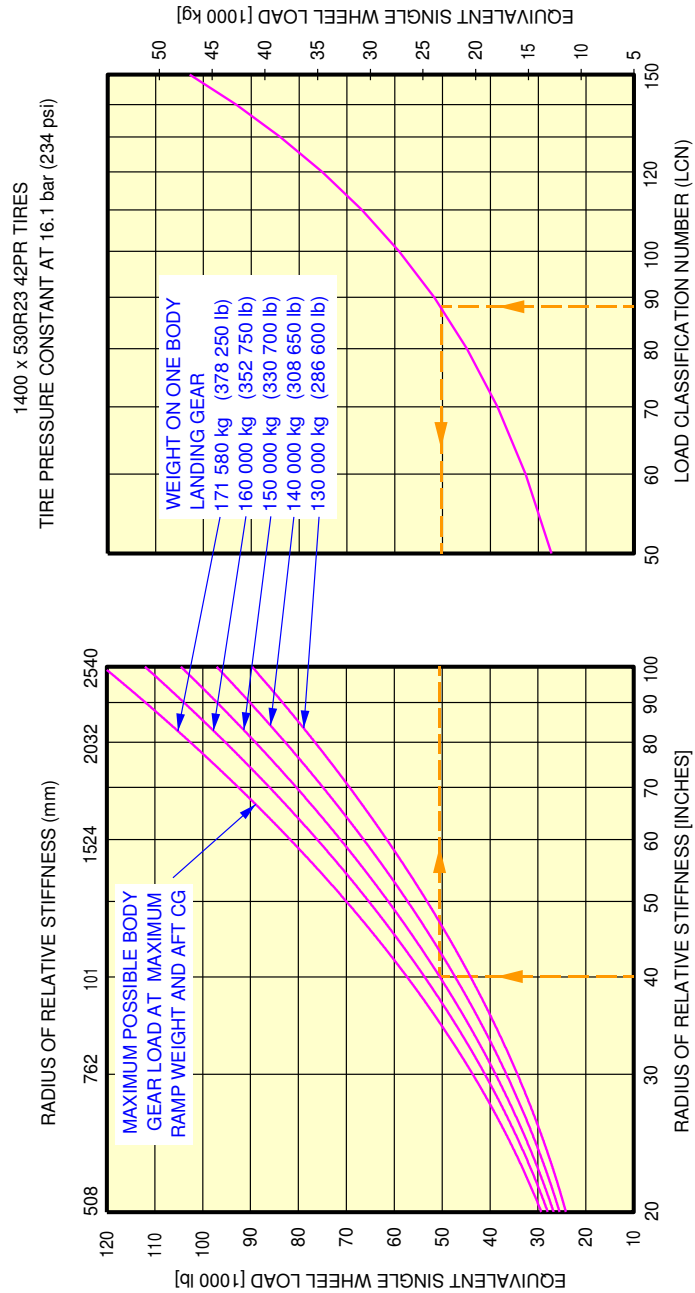

NOTE: EQUIVALENT SINGLE WHEEL LOADS ARE DERIVED BY METHODS SHOWN IN ICAO AERODROME MANUAL PART 2 PAR 4.1.3 Second Edition 1965

L_AC_070802_1_0080101_01_00

Rigid Pavement Requirements LCN - 6 Wheel Bogie
MRW 602 000 kg - A380-800F Models

7-8-3 Radius of Relative Stiffness (Other values of E and μ)

****ON A/C A380-800 Models A380-800F Models**

Radius of Relative Stiffness (Other values of E and μ)

1. General

The chart of Section 7-8-1 presents "L" values based on Young's Modulus (E) of 4 000 000 psi and Poisson's Ratio (μ) of 0.15.

To find "L" values based on other values of E and μ , see curves of section 7-8-4.

For example, to find an "L" value based on an E of 3 000 000 psi, the "E" factor of 0.931 is multiplied by the "L" value found in table of Section 7-8-1.

The effect of variations of μ on the "L" value is treated in a similar manner.

7-8-4 Radius of Relative Stiffness (Other values of E and μ)

**ON A/C A380-800 Models A380-800F Models

Radius of Relative Stiffness (Other values of E and μ)

1. This section gives Radius of Relative Stiffness.

**ON A/C A380-800 Models A380-800F Models

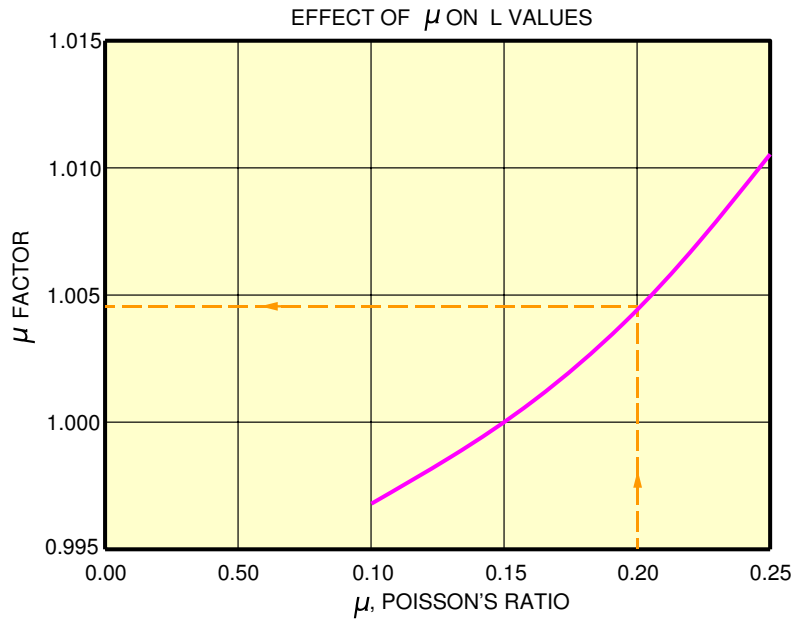
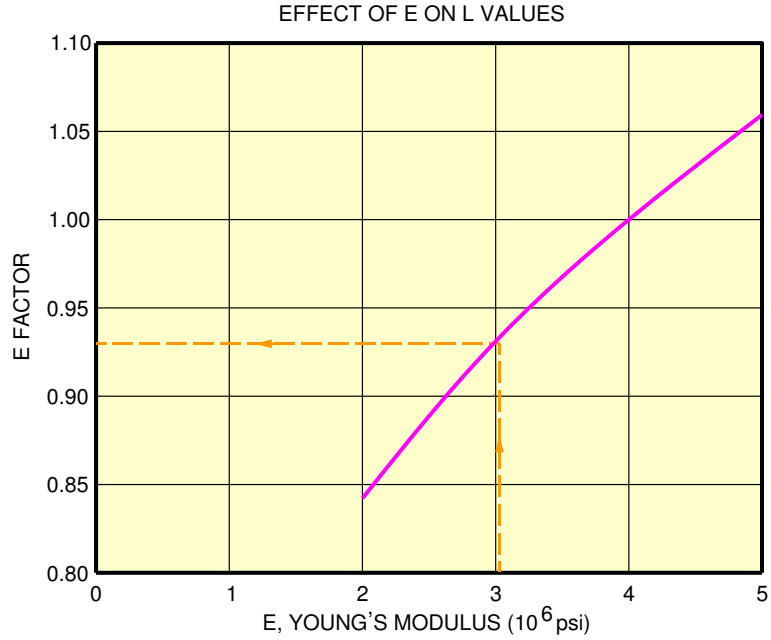

NOTE: BOTH CURVES ON THIS PAGE ARE USED TO ADJUST THE L VALUES OF TABLE 7-8-1

L_AC_070804_1_0010101_01_00

Radius of Relative Stiffness

7-9-0 ACN/PCN Reporting System

**ON A/C A380-800 Models A380-800F Models

ACN/PCN Reporting System

1. General

To find the ACN of an aircraft on flexible or rigid pavement, the aircraft gross weight and the subgrade strength must be known.

A380-800 model:

In the example shown in Section 7-9-1, with MRW 512000 kg, for an Aircraft Gross Weight of 440000 kg (970035 lb) and medium subgrade strength (code B), the ACN for the flexible pavement is 46.

In the example shown in Section 7-9-1, with MRW 562000 kg, for an Aircraft Gross Weight of 510000 kg (1 124360 lb) and medium subgrade strength (code B), the ACN for the flexible pavement is 56.

In the example shown in Section 7-9-1, with MRW 571000 kg, for an Aircraft Gross Weight of 510000 kg (1 124360 lb) and medium subgrade strength (code B), the ACN for the flexible pavement is 55.

In the example shown in Section 7-9-2, with MRW 512000 kg, for an Aircraft Gross Weight of 440000 kg (970035 lb) and medium subgrade strength (code B) the ACN for the rigid pavement is 46.

In the example shown in Section 7-9-2, with MRW 562000 kg, for an Aircraft Gross Weight of 510000 kg (1 124360 lb) and medium subgrade strength (code B) the ACN for the rigid pavement is 58.5.

In the example shown in Section 7-9-2, with MRW 571000 kg, for an Aircraft Gross Weight of 510000 kg (1 124 360 lb) and medium subgrade strength (code B), the ACN for the flexible pavement is 58.

A380-800F model:

In the example shown in Section 7-9-1, with MRW 592000 kg, for an Aircraft Gross Weight of 510000 (1 124 360 lb) and medium subgrade strength (code B), the ACN for the flexible pavement is 55.

In the example shown in Section 7-9-1, with MRW 602000 Kg, for an Aircraft Gross Weight of 510000 (1 124 360 lb) and medium subgrade strength (code B) the ACN for the rigid pavement is 55

In the example shown in Section 7-9-2, with MRW 592000 Kg, for an Aircraft Gross Weight of 510000 (1 124 360 lb) and medium subgrade strength (code B) the ACN for the rigid pavement is 60

In the example shown in Section 7-9-2, with MRW 602000 Kg, for an Aircraft Gross Weight of 510000 (1 124 360 lb) and medium subgrade strength (code B) the ACN for the rigid pavement is 60

NOTE : An aircraft with an ACN equal to or less than the reported PCN can operate on that pavement, subject to a limitation on the tire pressure. (Ref: ICAO Aerodrome Design Manual Part 3 Chapter 1 Second Edition 1983)



AIRPLANE CHARACTERISTICS

7-9-1 Aircraft Classification Number - Flexible Pavement

****ON A/C A380-800 Models**

Aircraft Classification Number - Flexible Pavement - Pax

1. This section gives the Aircraft Classification Number - Flexible Pavement.

****ON A/C A380-800 Models**

ACN WAS DETERMINED AS REFERENCED IN
 ICAO AERODROME DESIGN MANUAL PART 3
 CHAPTER 1 SECOND EDITION 1983.
 CG USED FOR ACN CALCULATIONS: 43 % MAC.
 See Section 7-4-1 Figure: Landing Gear Loading
 on Pavement - MRW 512 000 kg - A380-800 Models

1400 x 530R23 40PR TIRES
 TIRE PRESSURE CONSTANT AT 14 bar (203 psi)

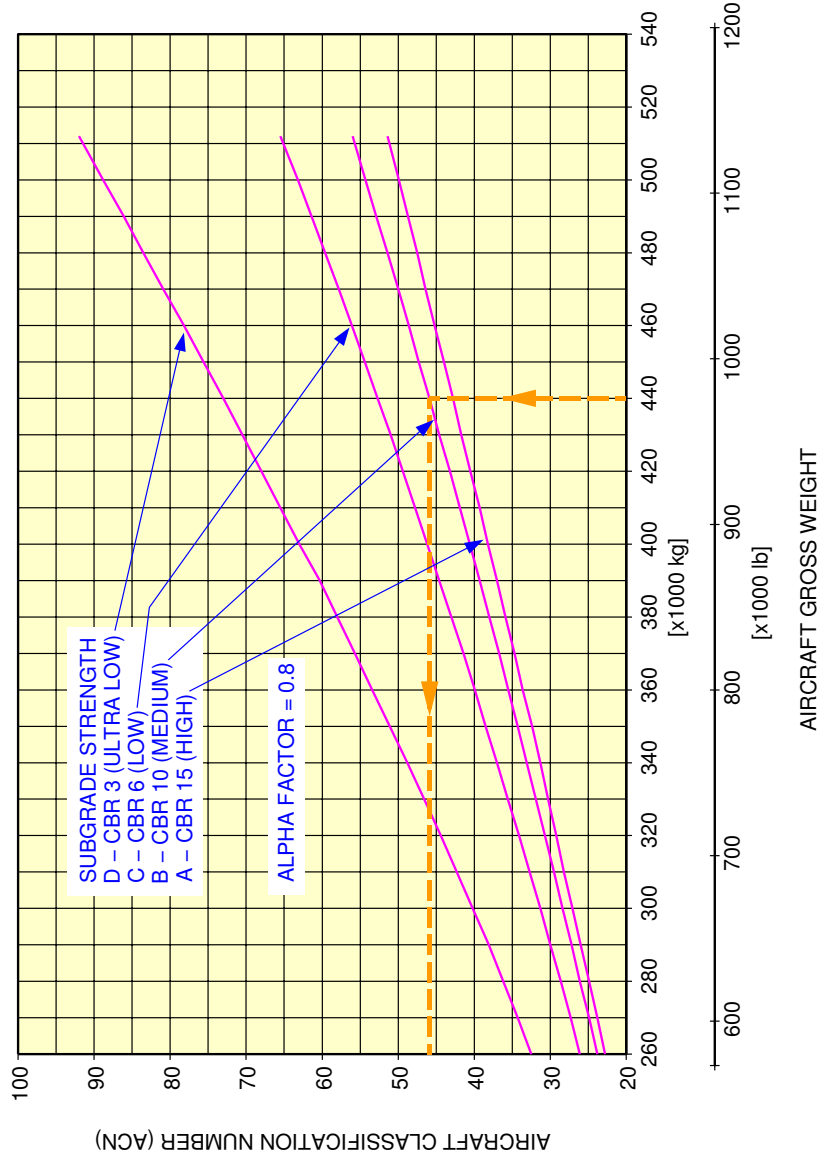

L_AC_070901_1_0050101_01_00

Aircraft Classification Number - Flexible Pavement
 MRW 512 000 kg - A380-800 Models

****ON A/C A380-800 Models**

ACN WAS DETERMINED AS REFERENCED IN
 ICAO AERODROME DESIGN MANUAL PART 3
 CHAPTER 1 SECOND EDITION 1983.
 CG USED FOR ACN CALCULATIONS: 43 % MAC.
 See Section 7-4-1 Figure: Landing Gear Loading
 on Pavement – MRW 562 000 kg – A380-800 Models

1400 x 530R23 40PR TIRES
 TIRE PRESSURE CONSTANT AT 15 bar (218 psi)

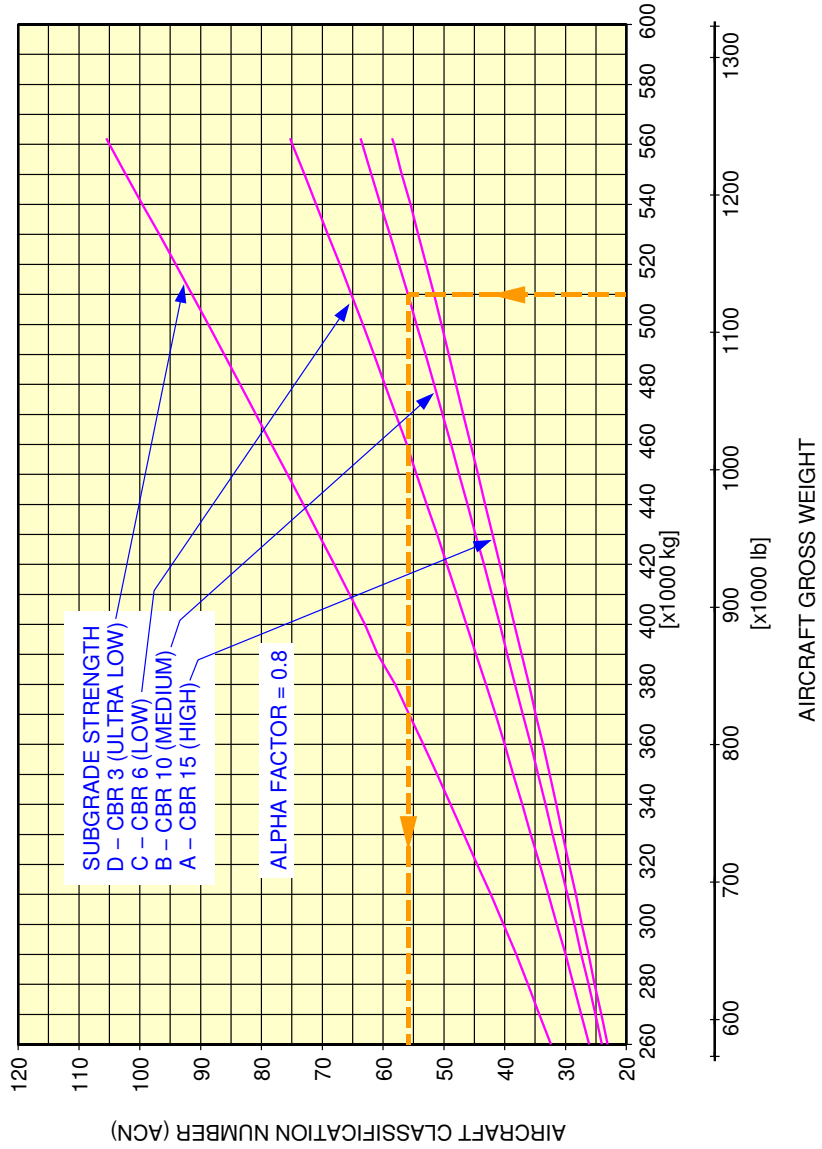

L_AC_070901_1_0060101_01_00

Aircraft Classification Number - Flexible Pavement
 MRW 562 000 kg - A380-800 Models

****ON A/C A380-800 Models**

ACN WAS DETERMINED AS REFERENCED IN ICAO AERODROME DESIGN MANUAL PART 3 CHAPTER 1 SECOND EDITION 1983. CG USED FOR ACN CALCULATIONS: 41 % MAC. See Section 7-4-1 Figure: Landing Gear Loading on Pavement - MRW 571 000 kg - A380-800 Models

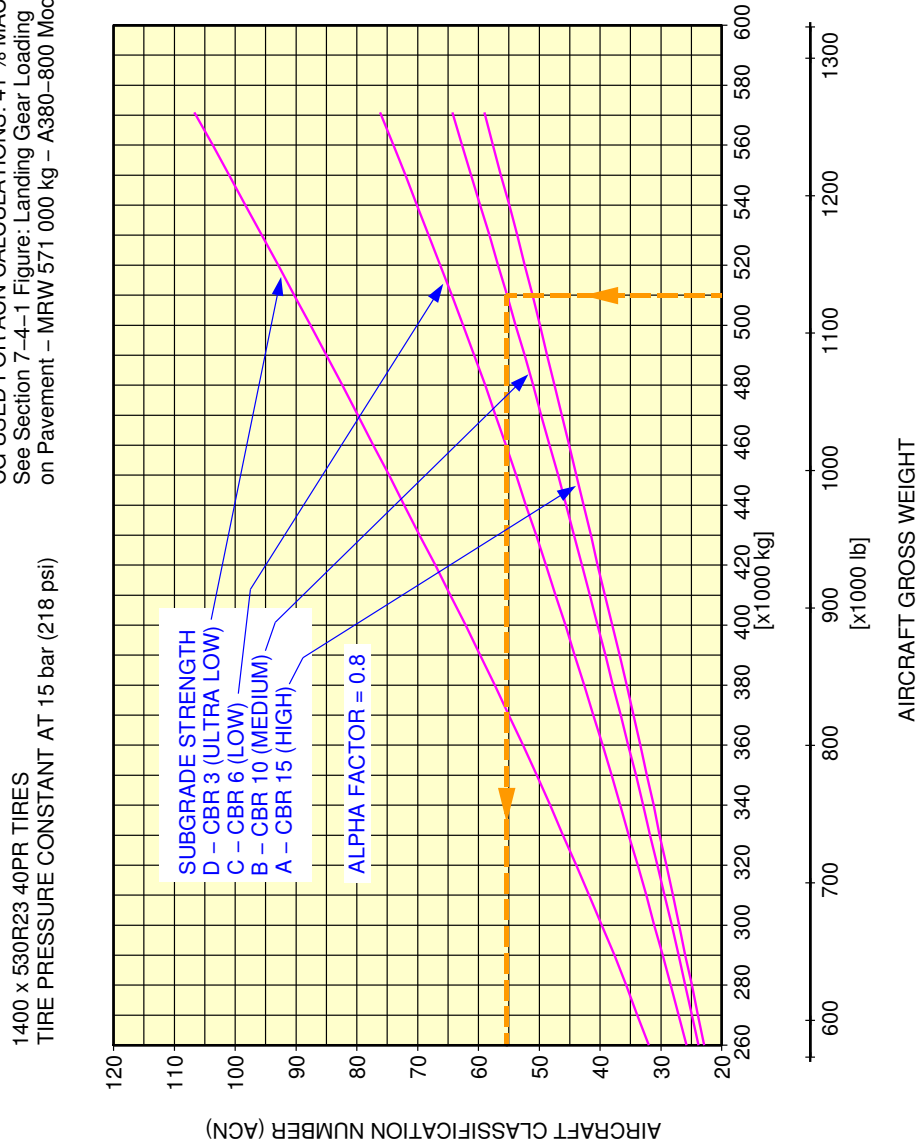

L_AC_070901_1_0070101_01_00

Aircraft Classification Number - Flexible Pavement
MRW 571 000 kg - A380-800 Models



AIRPLANE CHARACTERISTICS

****ON A/C A380-800F Models**

Aircraft Classification Number - Flexible Pavement - Freighter

1. This section gives the Aircraft Classification Number - Flexible Pavement.

****ON A/C A380-800F Models**

ACN WAS DETERMINED AS REFERENCED IN
 ICAO AERODROME DESIGN MANUAL PART 3
 CHAPTER 1 SECOND EDITION 1983.
 CG USED FOR ACN CALCULATIONS: 42.8 % MAC.
 See Section 7-4-1 Figure: Landing Gear Loading
 on Pavement - MRW 592 000 kg - A380-800F Models

1400 x 530R23 42PR TIRES
 TIRE PRESSURE CONSTANT AT 16.1 bar (234 psi)

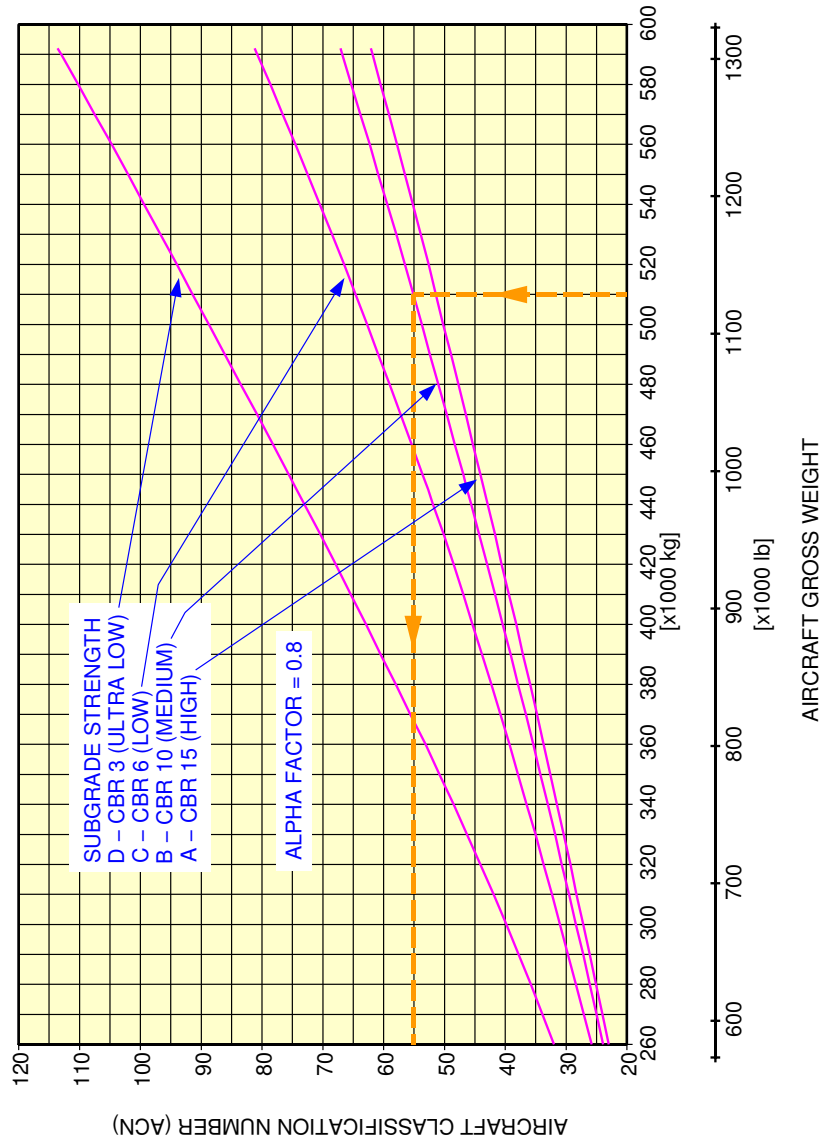

L_AC_070901_1_0080101_01_00

Aircraft Classification Number - Flexible Pavement
 MRW 592 000 kg - A380-800F Models

****ON A/C A380-800F Models**

ACN WAS DETERMINED AS REFERENCED IN
 ICAO AERODROME DESIGN MANUAL PART 3
 CHAPTER 1 SECOND EDITION 1983.
 CG USED FOR ACN CALCULATIONS: 42.7 % MAC.
 See Section 7-4-1 Figure: Landing Gear Loading
 on Pavement – MRW 602 000 kg – A380-800F Models

1400 x 530R23 42PR TIRES
 TIRE PRESSURE CONSTANT AT 16.1 bar (234 psi)

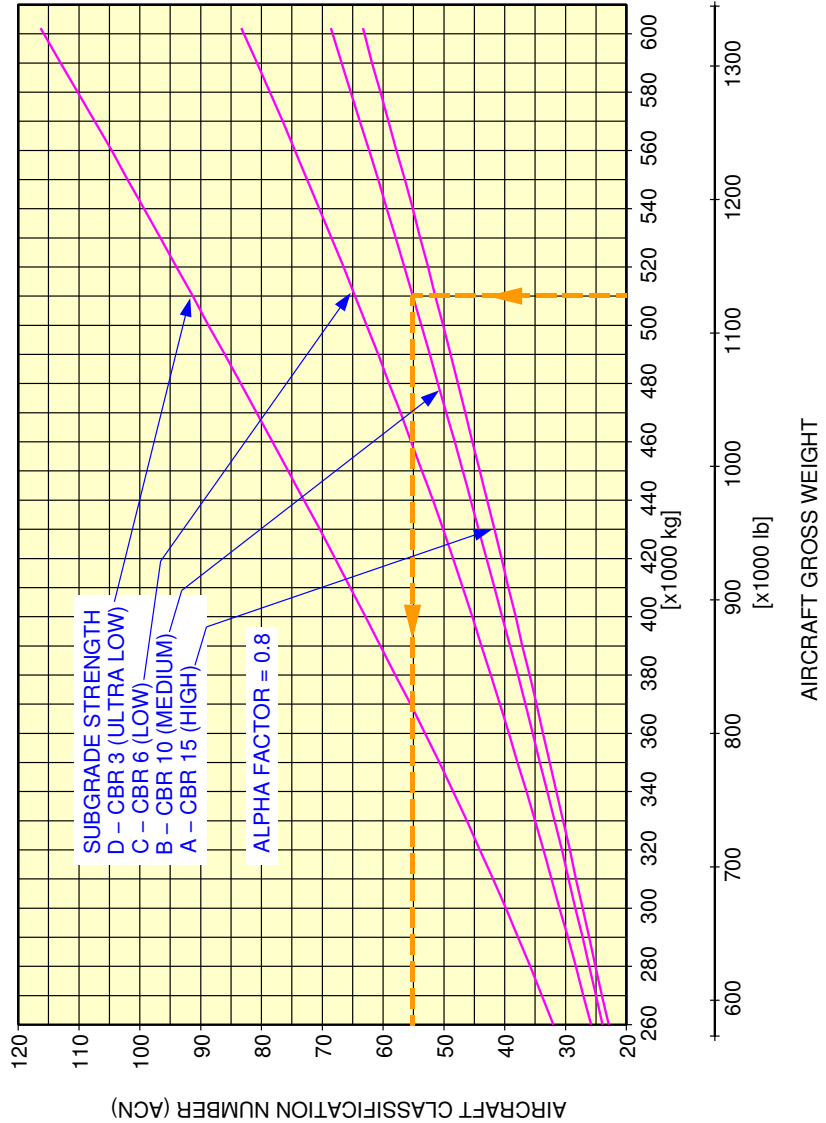

L_AC_070901_1_0090101_01_00

Aircraft Classification Number - Flexible Pavement
 MRW 602 000 kg - A380-800F Models



AIRPLANE CHARACTERISTICS

7-9-2 Aircraft Classification Number - Rigid Pavement

****ON A/C A380-800 Models**

Aircraft Classification Number - Rigid Pavement - Pax

1. This section gives the Aircraft Classification Number - Rigid Pavement.

****ON A/C A380-800 Models**

ACN WAS DETERMINED AS REFERENCED IN
ICAO AERODROME DESIGN MANUAL PART 3
CHAPTER 1 SECOND EDITION 1983.
CG USED FOR ACN CALCULATIONS: 43 % MAC.
See Section 7-4-1 Figure: Landing Gear Loading
on Pavement – MRW 512 000 kg – A380-800 Models

1400 x 530R23 40PR TIRES
TIRE PRESSURE CONSTANT AT 14 bar (203 psi)

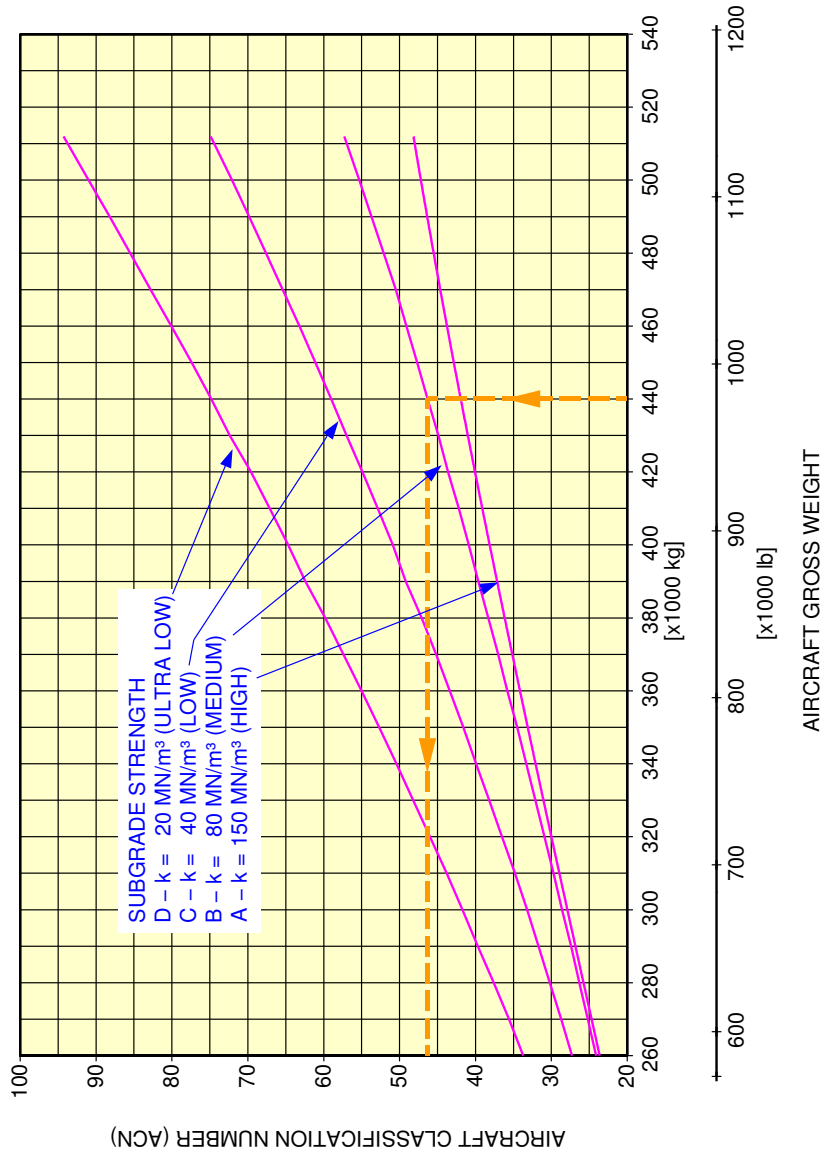

L_AC_070902_1_0050101_01_00

Aircraft Classification Number - Rigid Pavement
MRW 512 000 kg - A380-800 Models

****ON A/C A380-800 Models**

ACN WAS DETERMINED AS REFERENCED IN ICAO AERODROME DESIGN MANUAL PART 3 CHAPTER 1 SECOND EDITION 1983. CG USED FOR ACN CALCULATIONS: 43 % MAC. See Section 7-4-1 Figure: Landing Gear Loading on Pavement - MRW 562 000 kg - A380-800 Models

1400 x 530R23 40PR TIRES
TIRE PRESSURE CONSTANT AT 15 bar (218 psi)

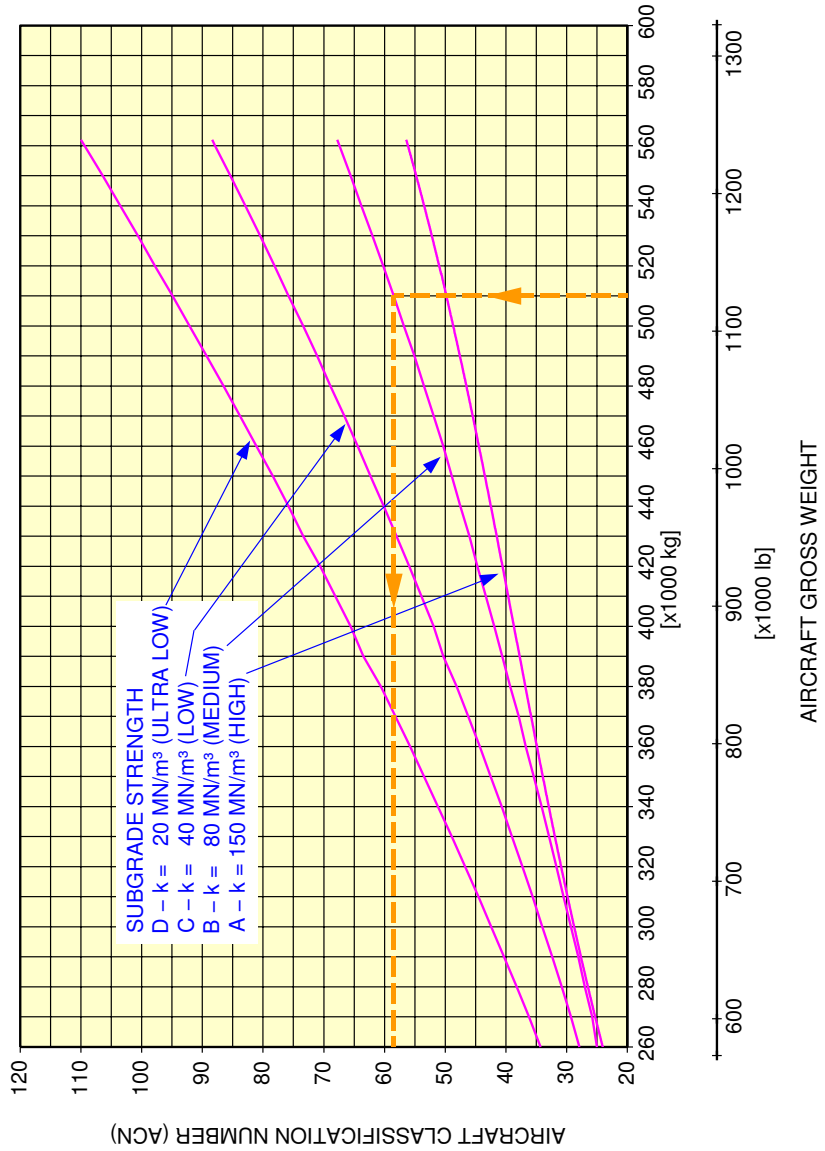

L_AC_070902_1_0060101_01_00

Aircraft Classification Number - Rigid Pavement
MRW 562 000 kg - A380-800 Models

****ON A/C A380-800 Models**

ACN WAS DETERMINED AS REFERENCED IN
ICAO AERODROME DESIGN MANUAL PART 3
CHAPTER 1 SECOND EDITION 1983.
CG USED FOR ACN CALCULATIONS: 41 % MAC.
See Section 7-4-1 Figure: Landing Gear Loading
on Pavement - MRW 571 000 kg - A380-800 Models

1400 x 530R23 40PR TIRES
TIRE PRESSURE CONSTANT AT 15 bar (218 psi)

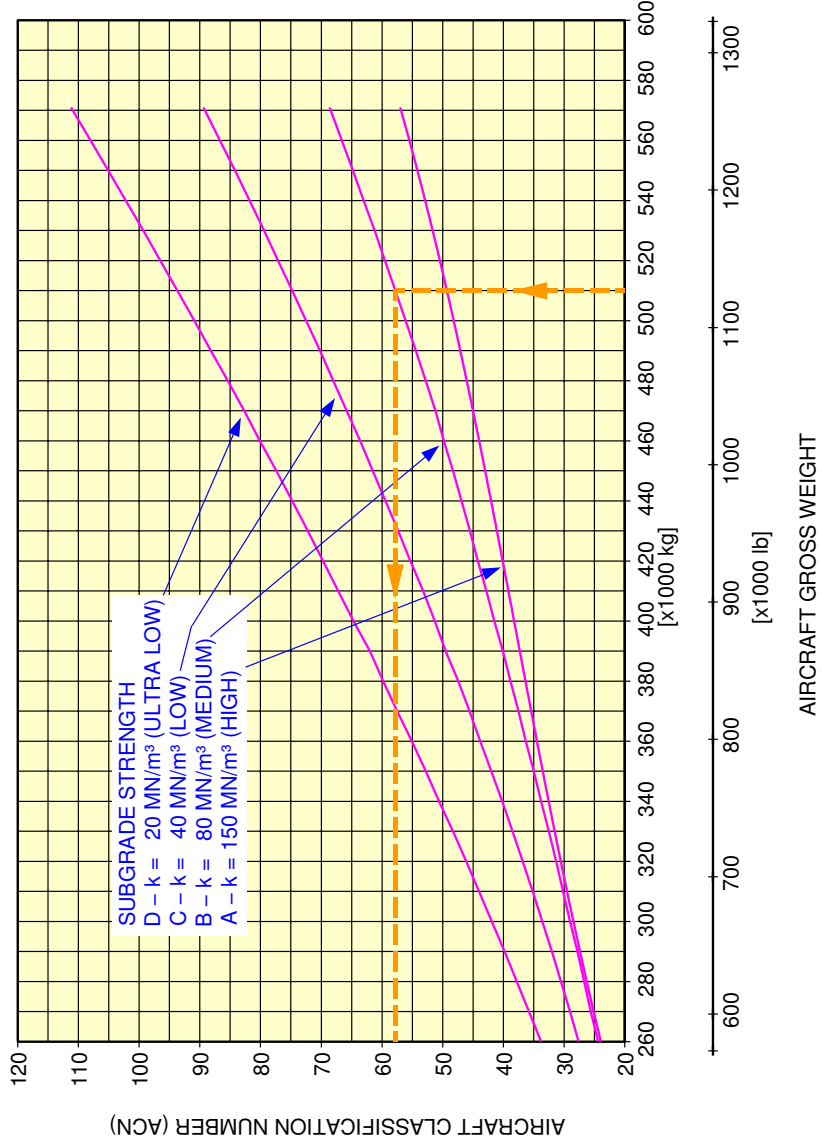

L_AC_070902_1_0070101_01_00

Aircraft Classification Number - Rigid Pavement
MRW 571 000 kg - A380-800 Models



AIRPLANE CHARACTERISTICS

****ON A/C A380-800F Models**

Aircraft Classification Number - Rigid Pavement - Freighter

1. This section gives the Aircraft Classification Number - Rigid Pavement.

****ON A/C A380-800F Models**

ACN WAS DETERMINED AS REFERENCED IN
 ICAO AERODROME DESIGN MANUAL PART 3
 CHAPTER 1 SECOND EDITION 1983.
 CG USED FOR ACN CALCULATIONS: 42.8 % MAC.
 See Section 7-4-1 Figure: Landing Gear Loading
 on Pavement – MRW 592 000 kg – A380-800F Models

1400 x 530R23 42PR TIRES
 TIRE PRESSURE CONSTANT AT 16.1 bar (234 psi)

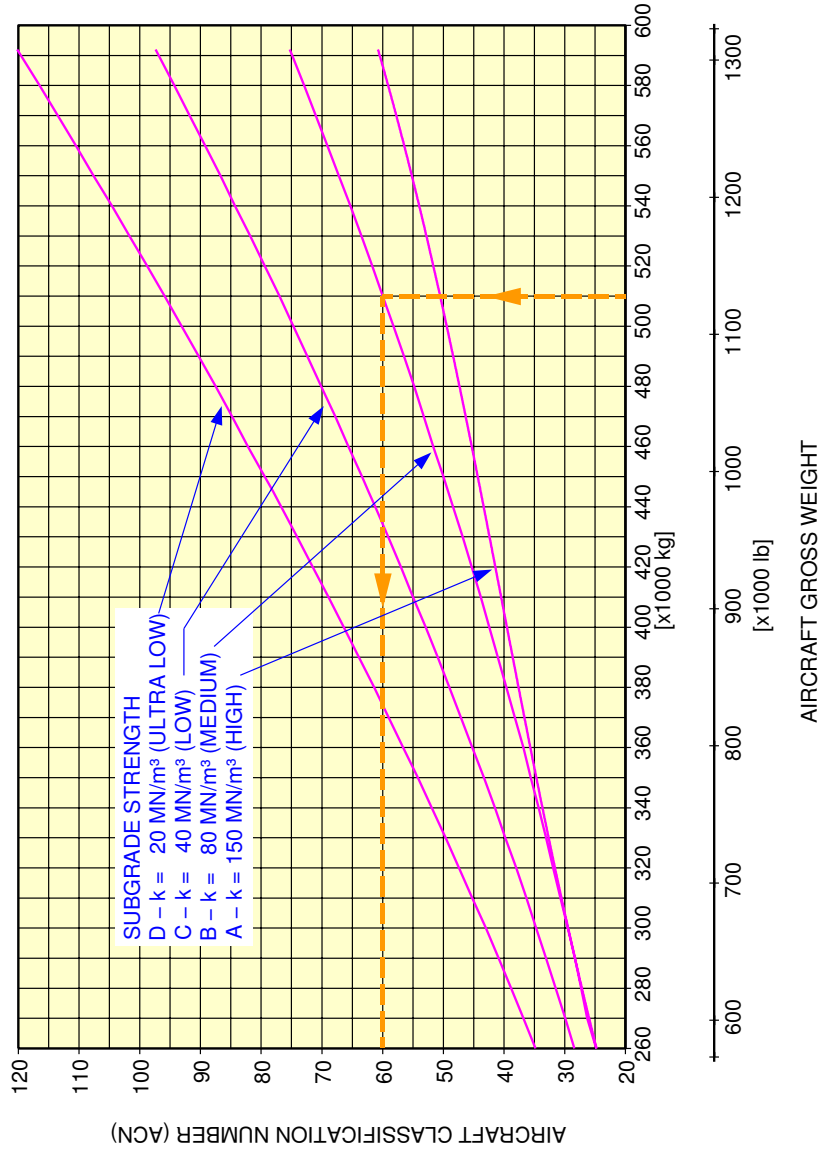

L_AC_070902_1_0080101_01_00

Aircraft Classification Number - Rigid Pavement
 MRW 592 000 kg - A380-800F Models

****ON A/C A380-800F Models**

ACN WAS DETERMINED AS REFERENCED IN ICAO AERODROME DESIGN MANUAL PART 3 CHAPTER 1 SECOND EDITION 1983. CG USED FOR ACN CALCULATIONS: 42.7 % MAC. See Section 7-4-1 Figure: Landing Gear Loading on Pavement – MRW 602 000 kg – A380-800F Models

1400 x 530R23 42PR TIRES
TIRE PRESSURE CONSTANT AT 16.1 bar (234 psi)

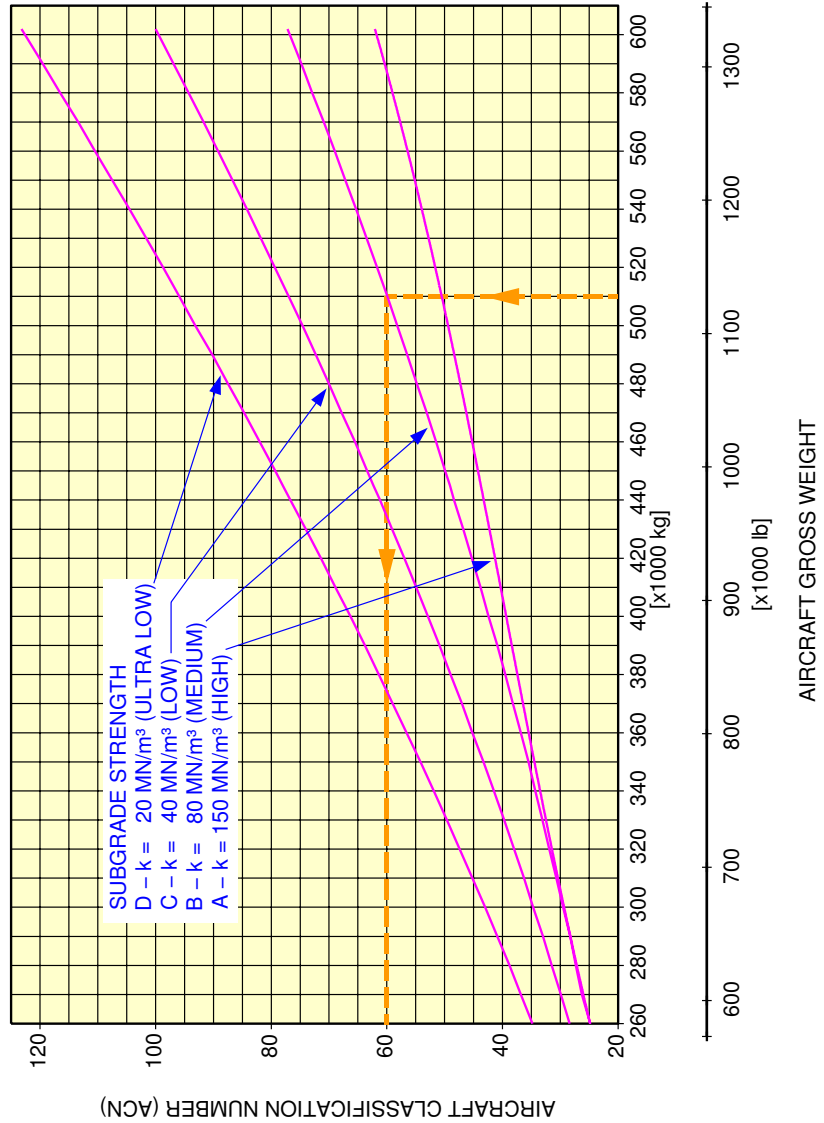

L_AC_070902_1_0090101_01_00

Aircraft Classification Number - Rigid Pavement
MRW 602 000 kg - A380-800F Models



AIRPLANE CHARACTERISTICS

DERIVATIVE AIRPLANES

8-1-0 Possible Future Derivative Airplanes

****ON A/C A380-800 Models A380-800F Models**

Possible Future Derivative Airplanes

1. General

A380 Family could be extended with several derivatives in order to provide additional capabilities to the operators. Those derivatives could impact payload capacity or range or both.



AIRPLANE CHARACTERISTICS

SCALED DRAWINGS

9-1-0 Scaled Drawing - 1 cm. = 500 cm.

****ON A/C A380-800 Models A380-800F Models**

Scaled Drawing - 1 cm. = 500 cm.

1. This section provides the Scaled Drawing - 1 cm = 500 cm.

**ON A/C A380-800 Models

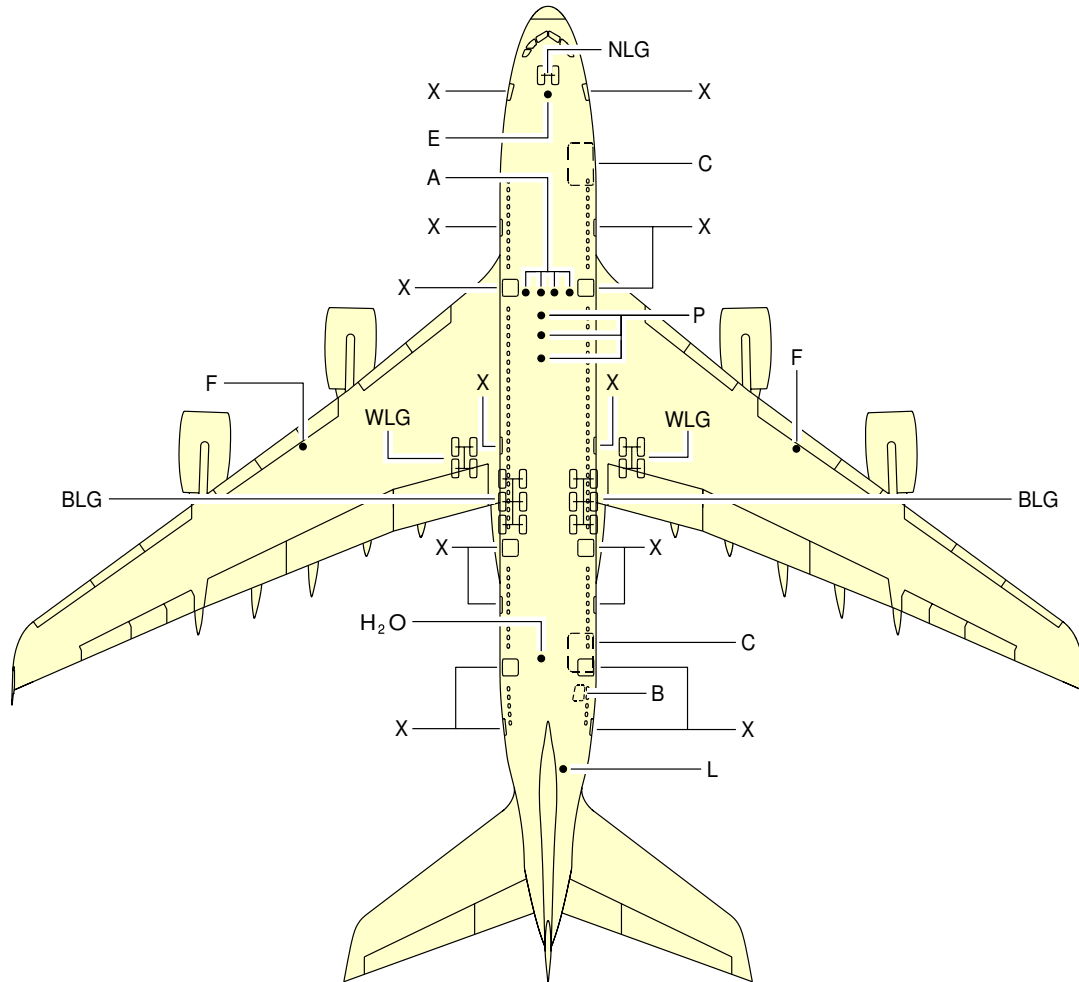

- A AIR CONDITIONING
- B BULK CARGO COMPT DOOR
- BLG BODY LANDING GEAR
- C CARGO COMPT DOOR
- E ELECTRICAL
- F FUEL
- H₂O POTABLE WATER
- L LAVATORY
- NLG NOSE LANDING GEAR
- P PNEUMATIC
- WLG WING LANDING GEAR
- X PASSENGER/CREW DOOR

DB1A

L_AC_090100_1_0010101_01_01

Scaled Drawing – 1 cm = 500 cm
A380-800 Models

****ON A/C A380-800F Models**

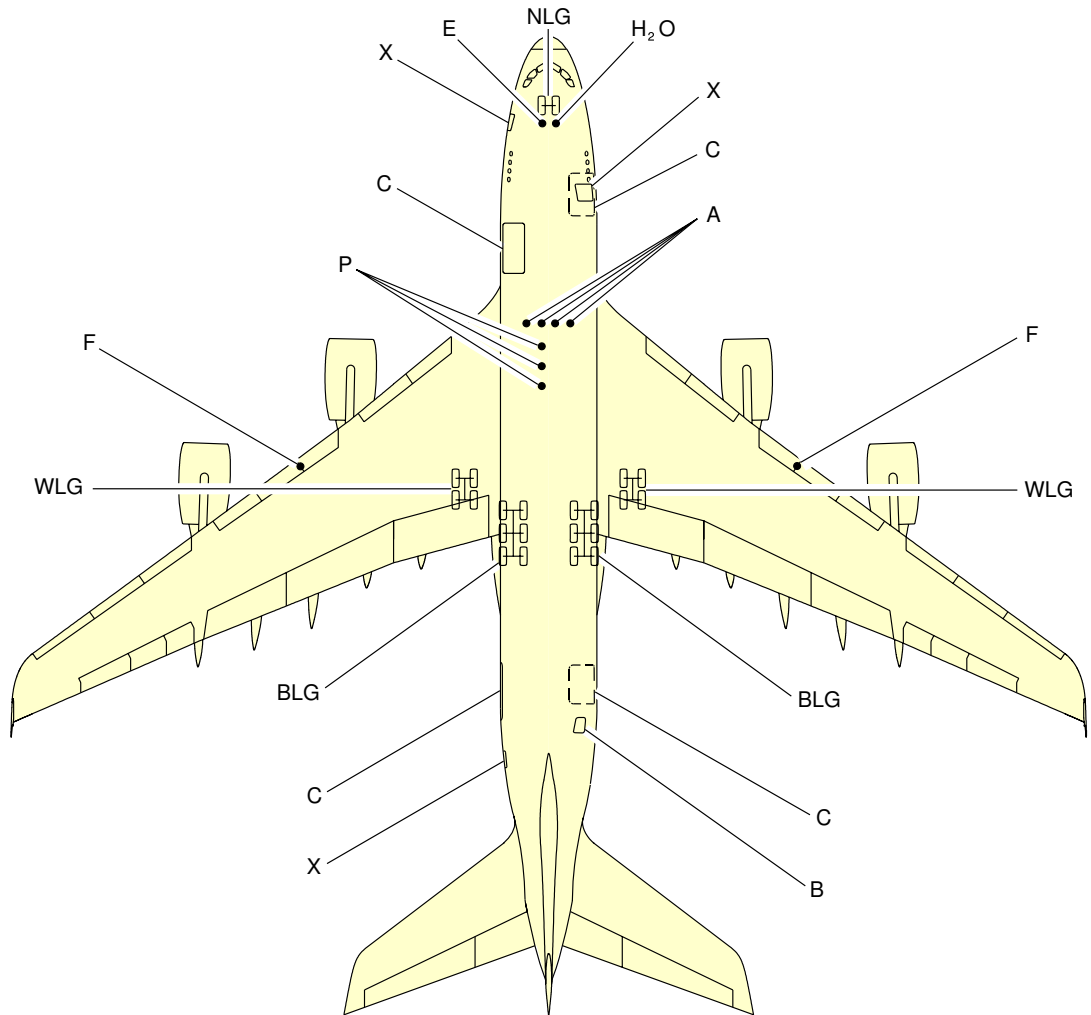

- A AIR CONDITIONING
- B BULK CARGO COMPT DOOR
- BLG BODY LANDING GEAR
- C CARGO COMPT DOOR
- E ELECTRICAL
- F FUEL
- H₂O POTABLE WATER
- L LAVATORY
- NLG NOSE LANDING GEAR
- P PNEUMATIC
- WLG WING LANDING GEAR
- X COURIER/CREW DOOR

DB1A

L_AC_090100_1_0020101_01_02

Scaled Drawing – 1 cm = 500 cm
A380-800F Models

****ON A/C A380-800 Models**

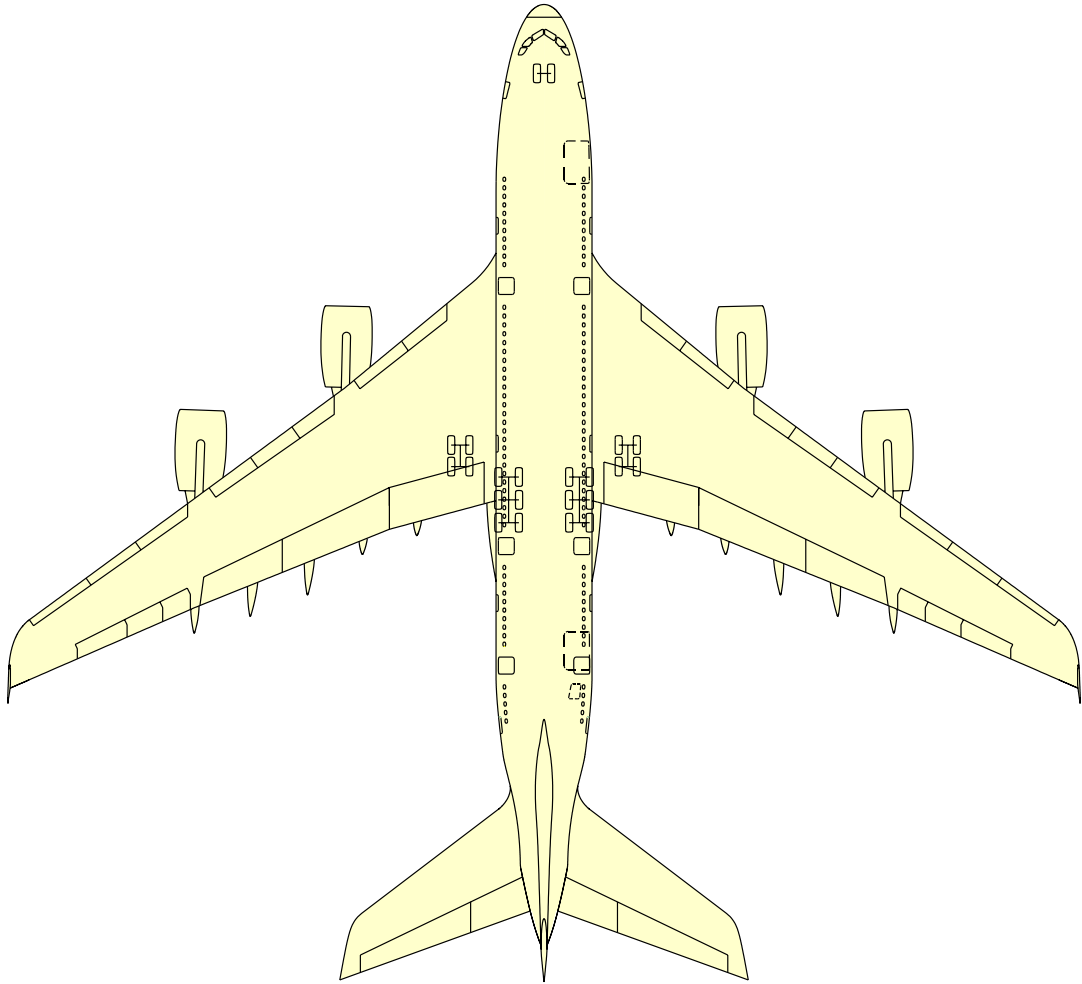

DB1A

L_AC_090100_1_0030101_01_01

Scaled Drawing – 1 cm = 500 cm
A380-800 Models

****ON A/C A380-800F Models**

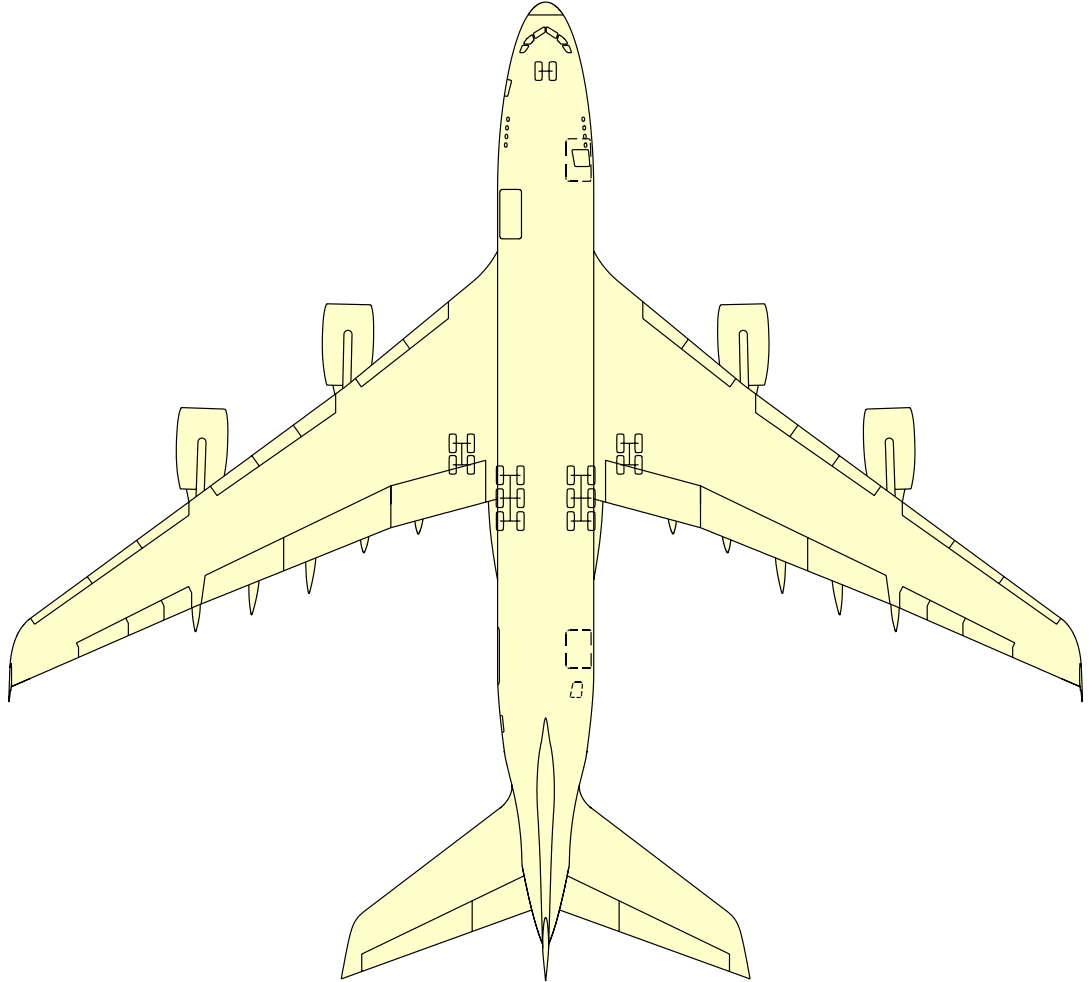

DB1A

L_AC_090100_1_0040101_01_01

Scaled Drawing – 1 cm = 500 cm
A380-800F Models



AIRPLANE CHARACTERISTICS

9-2-0 Scaled Drawing - 1 in. = 50 ft.

****ON A/C A380-800 Models A380-800F Models**

Scaled Drawing - 1 in. = 50 ft.

1. This section provides the Scaled Drawing - 1 in = 50 ft.

**ON A/C A380-800 Models

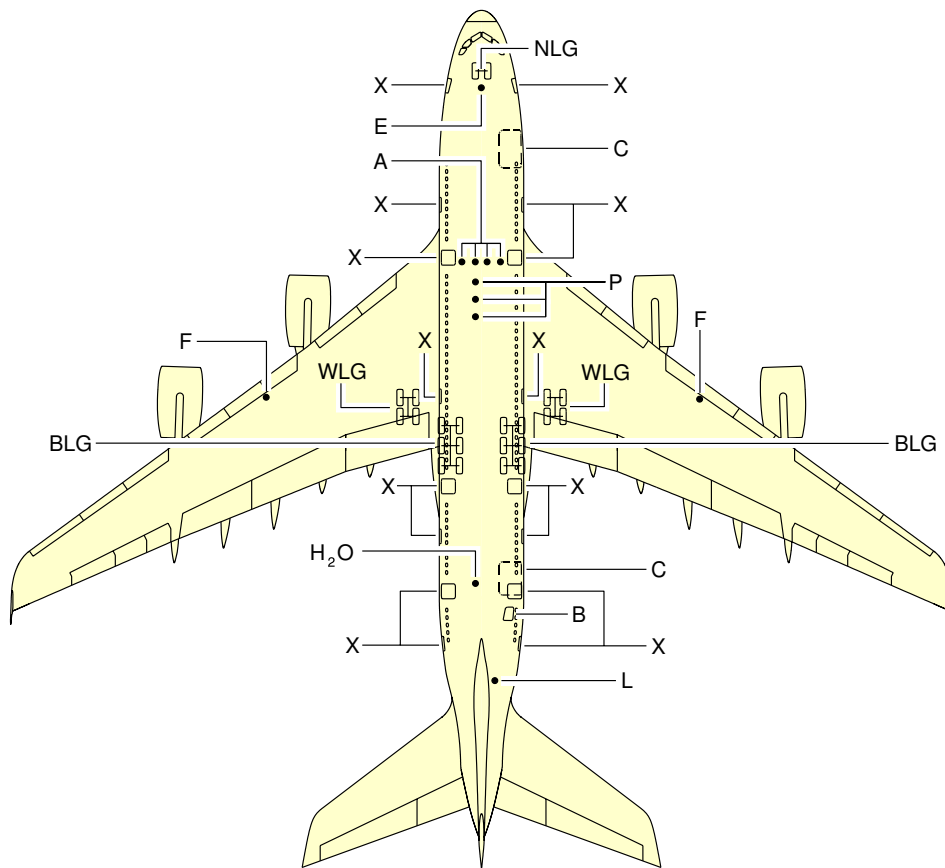

- A AIR CONDITIONING
- B BULK CARGO COMPT DOOR
- BLG BODY LANDING GEAR
- C CARGO COMPT DOOR
- E ELECTRICAL
- F FUEL
- H₂O POTABLE WATER
- L LAVATORY
- NLG NOSE LANDING GEAR
- P PNEUMATIC
- WLG WING LANDING GEAR
- X PASSENGER/CREW DOOR

DB1A

L_AC_090200_1_0010101_01_02

Scaled Drawing – 1 in = 50 ft
A380-800 Models

****ON A/C A380-800F Models**

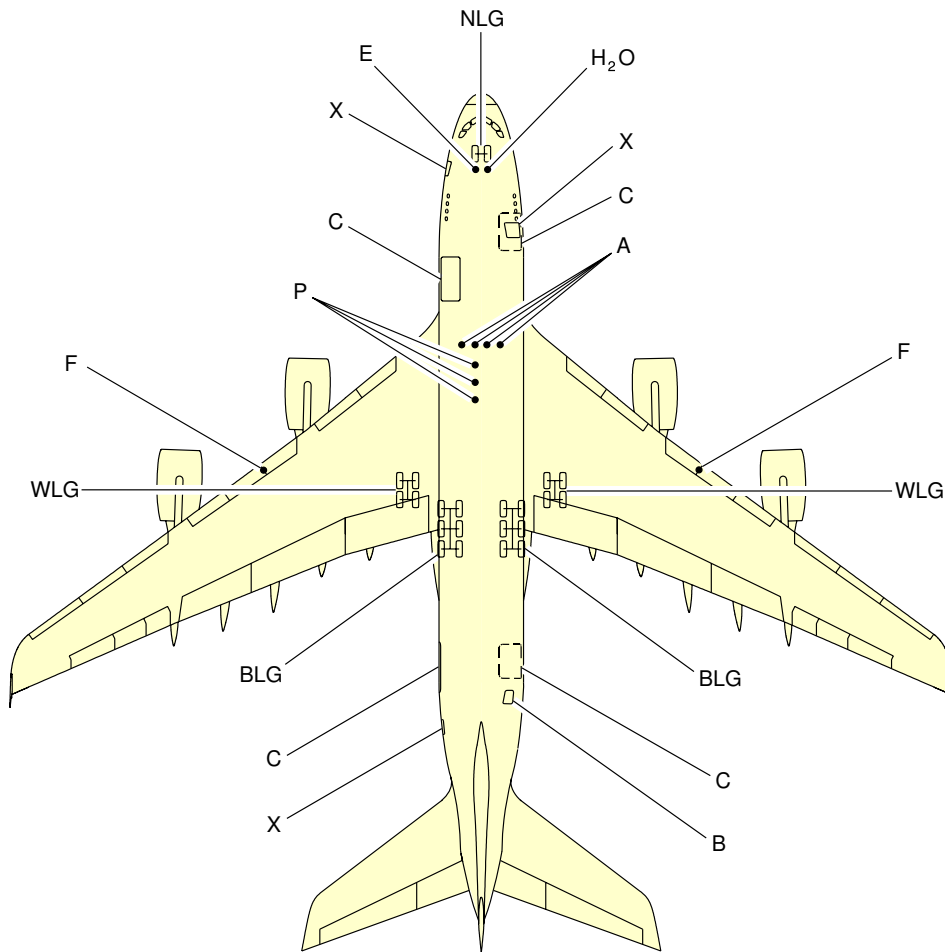

- A AIR CONDITIONING
- B BULK CARGO COMPT DOOR
- BLG BODY LANDING GEAR
- C CARGO COMPT DOOR
- E ELECTRICAL
- F FUEL
- H₂O POTABLE WATER
- L LAVATORY
- NLG NOSE LANDING GEAR
- P PNEUMATIC
- WLG WING LANDING GEAR
- X COURIER/CREW DOOR

DB1A

L_AC_090200_1_0020101_01_03

Scaled Drawing – 1 in = 50 ft
A380-800F Models

****ON A/C A380-800 Models**

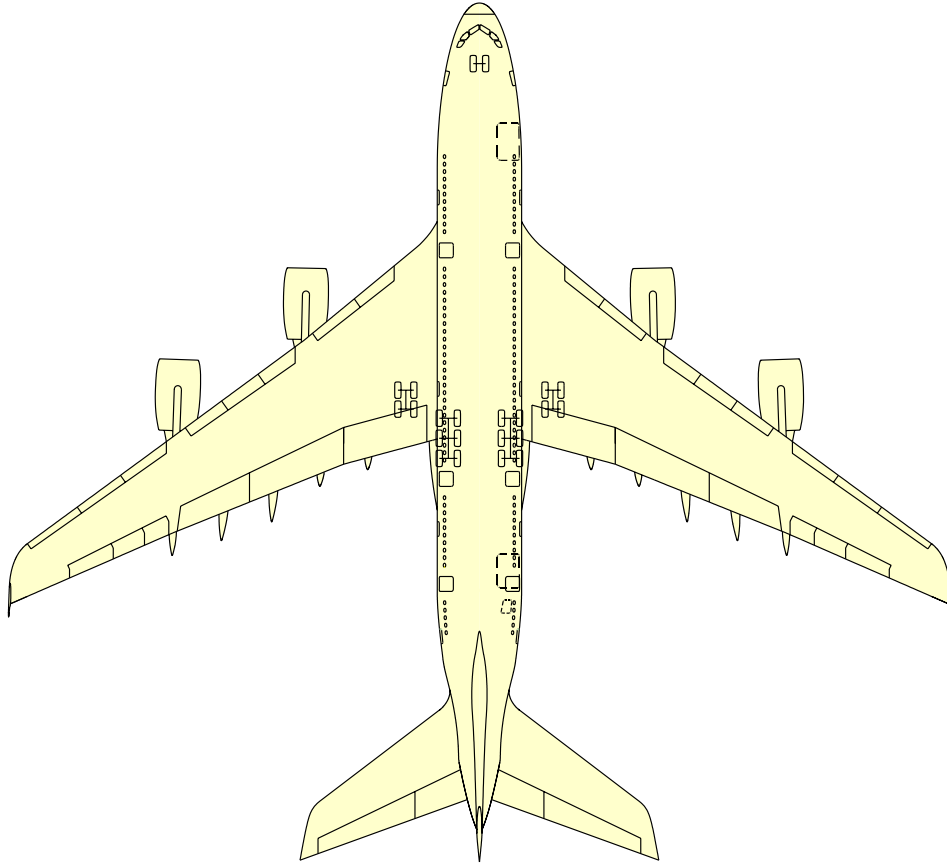

DB1A

L_AC_090200_1_0030101_01_02

Scaled Drawing – 1 in = 50 ft
A380-800 Models

****ON A/C A380-800F Models**

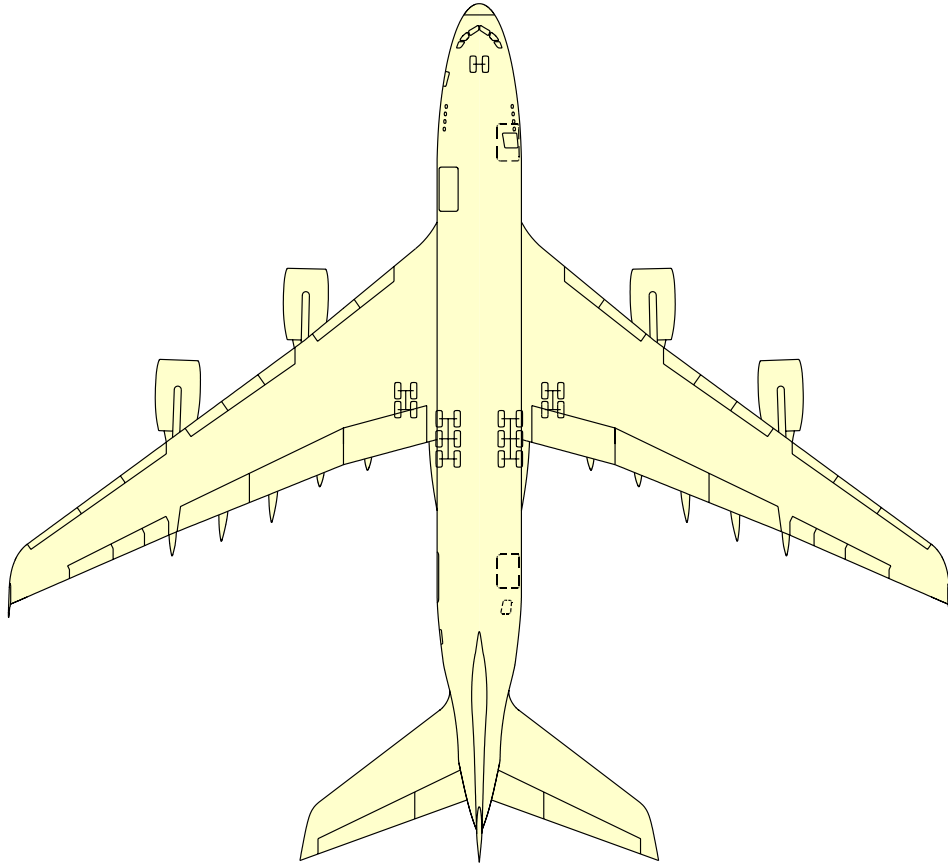

DB1A

L_AC_090200_1_0040101_01_02

Scaled Drawing – 1 in = 50 ft
A380-800F Models