

## ARRIVE EARLY

Plan your trip so that you're at the venue well before the scheduled start of the event. Gates open **one to two hours** before the start of competition at city and Whistler venues. Gates open **four hours** prior to the start of the Opening Ceremony, **three hours** prior to the start of the Closing Ceremony and **two hours** prior to the start of the Victory Ceremonies.

## TRAVELLING TO VENUES

In Metro Vancouver, public transit is the best way to go. If you're heading to Whistler, options include commercial motorcoach and rideshare/carpool. Parking for spectators is at the Whistler Paralympic Park spectator parking lots (see map on [page 45](#)).

## DRESS APPROPRIATELY

Dress for cold and wet weather — warmly, in layers and in waterproof clothing. Remember to wear suitable footwear as you may have to walk on uneven, snowy or icy surfaces.

## HAVE YOUR TICKETS READY

Be sure to have your tickets with you as you must have a valid ticket to enter a venue. Treat your tickets like cash; lost or stolen tickets will not be replaced or refunded.



## PREPARE FOR THE SECURITY SCREENING

Avoid taking large bags to the venues. If you are unsure of what you can and cannot bring with you, check the prohibited and restricted items list on [page 26](#).

## YOUR PAYMENT OPTIONS

Visa cards and cash are the only methods of payment accepted at Paralympic venues.

## ACCESSIBILITY

All venues have been reviewed for accessibility. If you have a specific need, see the nearest staff member for assistance.

## BE INFORMED

At the venue, look for wayfinding signage, listen to announcements and read the message boards — this will provide you with the information you need to make the most of your experience. Is there still something you need to know? Don't hesitate to visit our information booths located at each venue.

A stylized landscape illustration in shades of blue and green. In the background, there are blue mountains and a light blue sky with several white birds in flight. A white propeller plane is flying in the upper right. In the middle ground, there are rolling green hills and a cluster of wind turbines on the left. The foreground features a dark blue river or path that curves across the bottom. A large, dark teal rectangular box with a white border is positioned in the lower right, containing the title and table of contents.

# SPECTATOR INFORMATION

AT THE VENUE 26

VENUE FACILITIES AND SERVICES 30

SPECTATORS WITH A DISABILITY 32

KNOW YOUR TEAM 2010 VOLUNTEERS 33

STAY HEALTHY 34



## 5 THINGS TO REMEMBER BEFORE YOU LEAVE HOME

- 1** Know before you go. Plan your trip ahead of time so you don't miss the start of a competition. Arrive early — give yourself plenty of time to get to your seats and get settled.
- 2** Make sure you have your tickets with you and that you're carrying valid tickets, for the correct venue, session, date and time.
- 3** Bring a Visa card or cash as these are the only accepted payment methods at the venues.
- 4** Learn what you can and cannot bring into the venue. See page 26 for details.
- 5** Be prepared for sun, snow and rain. Wear appropriate clothing and bring sunscreen and sunglasses.

### WHAT TO BRING

Carry small bags only as there is limited space within the venue seating and no bag-check area.

Check the prohibited and restricted items list on page 26 to make sure you're not carrying anything that will be confiscated.



Do not bring food or beverages from home. These can be purchased at concession stands within the venues.

### TIP

Remember, once you enter a venue you will not be able to leave and re-enter. Make sure you have everything you'll need during your event.

## WHAT TO WEAR

Weather in Vancouver and Whistler can be unpredictable and can change very quickly.

At **mountain venues**, you may be outside for extended periods of time with limited or no access to shelter. You may be required to walk on slippery, snow-covered slopes so it is a good idea to wear well-insulated winter boots with good traction.

**City venues** can also be quite cold, so dress appropriately and be prepared to be in a chilly environment for several hours.



It's easy to remember what to wear: think **C-O-L-D**.

**Cover** your head, neck and face since most heat loss occurs from these areas. Wear a hat, scarf and gloves or mittens, and remember to put on lip protection.

**Overexertion** can make you sweat, making your clothes damp or wet. This could cause you to become chilled more quickly. Dress in layers so you can remove them as needed, before you begin to perspire.

**Layer** clothing to protect yourself against wind and cold. Start with a close-fitting inner layer that allows sweat to escape. The second, insulating layer should be loose and warm. The outer layer should be windproof and waterproof.

**Dry.** Wear waterproof clothing and insulated, waterproof boots and gloves. Ensure they are not too tight as this could decrease circulation to your hands and feet, increasing your risk of frostbite.

### Tip

Keep moving. Limit the amount of time you spend sitting or standing in one place. Move around to keep your blood flowing.

### Tip

Eat and drink. Food helps maintain body heat. Fluids such as water and juice keep you from becoming dehydrated, which can lead to hypothermia.

# AT THE VENUE

## CONDITIONS OF ENTRY

To access Paralympic venues spectators must:

- Carry a valid ticket.
- Undergo a security screening at Opening and Closing Ceremonies.
- Respect the venue code of conduct and all house rules, including those concerning prohibited and restricted items and actions as listed below.

Spectators not complying with the above rules may be asked to leave the venue.

## PROHIBITED ITEMS AND ACTIONS

Prohibited items and actions are those prohibited by Canadian law.

The following items and actions are not permitted at venues:



- ammunitions
- criminally prohibited weapons
- explosive substances
- firearms, replica firearms, toy guns
- knives
- pepper spray
- public incitement of hatred
- wilful promotion of hatred

## RESTRICTED ITEMS AND ACTIONS

Selected items and actions are identified as restricted in order to ensure the safety and enjoyment of all spectators at the Paralympic Winter Games, ensure the laws and provisions are upheld, and the contractual obligations to third parties are respected.

**Spectators carrying restricted items will be asked to either return them to their point of origin or dispose of them immediately.**



**Aerosol sprays, flammable liquids, fireworks, water balloon launchers**

**Ambush marketing** of any kind, distribution of leaflets, pamphlets and non-approved publications, promotional material and wearables

**Animals**  
(except service animals)

**Balls, Frisbees, racquets, hockey sticks, pucks** and other sport items

**Bicycles, scooters, skateboards, skates, skis, snowboards, sleds**

**Broadcast and lighting equipment** from entities other than rights-holding accredited broadcasters and the host broadcaster



**Broadcasting and recording** through the use of mobile phones or other transmitting devices (such as two-way radios, recording devices, PDAs or video cameras) for commercial purposes

**Dangerous, disruptive behaviour** or behaviour which disturbs spectators (including, without limitation, public drunkenness, fighting, gambling, spitting, threatening staff or spectators, throwing objects onto the field of play and/or public seating area, political or religious activities)

**Displays of signage and banners containing religious, political, provocative or obscene content and/or visible branding and trademarks of sponsor and non-sponsor companies;** flags of non-participating countries; flags and banners larger than 2 m x 1 m; poles larger than 0.9 m (flags cannot be attached to any surface in the venue)

**Devices capable of causing a disturbance** such as air horns, trumpets, lasers, thundersticks and **noisemaking** that might disrupt the session or be disturbing to other spectators

**Drugs, needles, prescription-strength medicines** not validly prescribed for the ticket bearer by a physician

**Flash photography** and other lighting devices (such as laser pens) anywhere around the field of play (exceptions may apply)

**Food and beverages**, including alcohol, purchased outside of the venue (except for medical needs)

**Folding chairs or benches** (stadium cushions are allowed in mountain venues)

**Glass containers or bottles**

**Golf umbrellas**, open umbrellas in seating areas disrupting spectators' views

**Large bags** (bags small enough to fit under a seat and not obstruct aisles are allowed) containers, coolers, ice chests

**Smoking** (except in designated areas)

**Strollers** in a seating bowl or viewing area

**Unauthorized collection of money** or commercial activity (such as hawking, ticket resale), sale of counterfeit goods

**Use of radio frequency devices** (Wi-Fi, pocket wizards and land mobile radios) that have not been registered and coordinated with Industry Canada prior to entry into the venue

## SECURITY SCREENING

Opening and Closing Ceremonies will have a security screening process which includes metal detection. Due to the large number of spectators, be prepared to wait in line for your turn to pass through the screening process. Here are a few tips to help your security screenings go more quickly:

**Cooperate with staff** at all times and follow their directions.

**Follow the spectator marshal's instructions** and move into the correct lineup. Spectators carrying no bags or small bags (no larger than 15 cm x 15 cm x 30 cm or 6 in x 6 in x 12 in) will move into the express line. Spectators carrying larger bags will follow the standard line.

**Be prepared** to empty your pockets.

**Be prepared** to have your bag and the contents of your pockets inspected.

**Spectators will be asked to go through a magnetometer** (metal detector). Let a staff member know if, for medical reasons, you're not comfortable doing this.

**Spectators with a disability** will be directed to a separate gate.

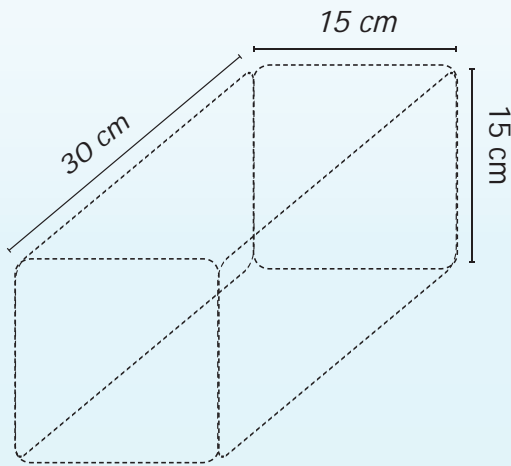

**Tip** Paralympic venues are busy places. Once you enter the venue, set up a meeting point with your family and friends.

## HOW TO PAY

Visa cards and cash are the only accepted forms of payment at Paralympic venues. Visa is the only card accepted to obtain cash at ATMs at Paralympic venues. Non-Visa debit cards will not be accepted.

## RECYCLING AND WASTE

We are pursuing a zero waste management strategy. You can help us reach our 85 per cent diversion from landfill target by doing the following:

**Put your waste and recyclables** in the proper bins (general waste, plastics, compostables, bottles).

**Take your waste and recyclables** off all buses and place it in the proper bin at the nearest recycling station.

**Recycle paper cups** in the compostables bin.

**Drop off used batteries** at any information booth.

**Use the ashtrays** provided in the designated smoking areas for your cigarette butts.

Litter is unsightly and poses a threat to wildlife. Please ensure a litter-free experience for everyone at the Games.

**DID YOU KNOW** that recycling a plastic bottle saves 60 per cent of the energy it takes to make one from scratch?





# VENUE FACILITIES AND SERVICES



## INFORMATION BOOTHS

Located in each venue, information booths provide spectators with details on competition times, results, and transportation and tourist information. As well, information booths at many of the venues can help with ticket resolution issues. Lost and found is also located at the information booths.



## LOST AND FOUND

If you have lost or found an item, please go to the nearest information booth for assistance. Items turned into the information booth are logged and remain at the venue until the end of the day. They are then transported to the Lost and Found Claims Centre where they can be reclaimed after approximately 24-48 hours at:

**450 West Broadway, Vancouver, BC**  
**Phone 1 778 328 1111**

**Lost children** should be reported to the nearest staff member. It's a good idea to write your child's first name, and the parents' phone number, inside his/her coat. When you arrive at the venue, point out to your child staff who can help them should they become separated from you.



## STROLLER STORAGE

Strollers are allowed at Paralympic venues but restricted within the seating areas. Storage for strollers, wheelchairs, scooters and child-carrier backpacks is available at all venues. VANOC does not assume responsibility for any loss or damage to items left in the storage area.



## CONCESSIONS

Venue concession stands feature a wide variety of hot and cold food and beverage items, including healthy meal choices. Beer and wine are available for purchase and must be consumed in designated areas. Spectators are not permitted to bring any food or beverages purchased from outside the venue.



**Tip** Venues are an exciting place to be. Use your senses and keep an eye on what's going on around you — such as messaging on video boards, loudspeaker announcements and signage — to make the most of your experience.



## MERCHANDISE

Official merchandise, including sport-specific and Team Canada merchandise, is sold at Olympic Stores and dedicated locations within all Vancouver 2010 venues. Merchandise kiosks are marked on venue maps.



## AUTOMATED TELLER MACHINES (ATMs)

Automated teller machines are available at select venues. ATMs will accept Visa cards only.



## SMOKING AREAS

All Vancouver 2010 venues are smoke- and tobacco-free. Smoking is permitted only in designated smoking areas. If you need assistance in finding the smoking areas, please ask a staff member for help.



## FIRST AID

In the event of an emergency, locate a uniformed volunteer for immediate assistance. If you require less urgent medical attention, please proceed to the clearly marked medical stations. First aid/medical stations and mobile medical teams are located in spectator areas at all Paralympic venues.

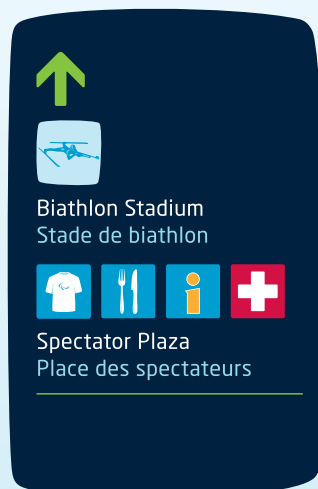

## VENUE SIGNAGE

Information signs in both English and French make finding your way around the venues easy.

# SPECTATORS WITH A DISABILITY

VANOC is committed to providing accessible venues and services for the Paralympic Winter Games.

Venues have been reviewed for accessibility and include consideration for persons with vision impairment, blindness, hearing loss, D/deafness as well as mobility and/or agility impairments, as follows:

**Accessible seating options** (with adjacent companion seating).

**Accessible washroom facilities** and amenities.

**Assisted hearing devices**, available for loan at the information booths.

**Assistance/guide dogs** are welcome in the venue and a dog relief area will be available.

**Live audio description services** will be available in English and French for the Opening and Closing Ceremonies for spectators with visual impairments. Receivers will be available for loan at the information booths.

**Sign Language interpretation** will be available at Opening and Closing Ceremonies.

**Wheelchairs**, available for loan at the information booths.

**Accessible shuttle service**, available at outdoor venues where travel over longer distances is required.

**Tip** Accessible seating is available at all venues and can be requested through the ticketing process.



# KNOW YOUR TEAM 2010 VOLUNTEERS

Throughout the Vancouver 2010 Paralympic Winter Games, there will be welcoming faces all around you — they are Team 2010 volunteers. Take a moment to identify their uniforms and badges, and feel free to ask for their assistance at any time.

Canada's diverse culture provides VANOC with a rich language pool. Many of the Team 2010 volunteers will be happy to assist you in your preferred language.



English and French are Canada's official languages. French-speaking volunteers will be wearing a "Bonjour" pin on their uniform.



# STAY HEALTHY

To ensure you enjoy a safe and healthy stay in the Vancouver and Whistler areas during the 2010 Winter Games, please make note of the following:

## 2010 WINTER GAMES SPECTATOR HOSPITAL

**St. Paul's Hospital**  
1081 Burrard Street, Vancouver, BC  
1 604 682 2344

## WHISTLER HEALTH CARE CENTRE

4380 Lorimer Road, Whistler, BC  
1 604 932 4911

## HEALTH INFORMATION

For non-emergencies, general health information may be accessed 24 hours a day by dialing **8-1-1** (HealthLink BC). If you're unable to dial **8-1-1** from your calling area, please call **1 604 215 8110** or **1 866 215 4700**.

## MEDICAL TRAVEL INSURANCE

Before leaving home, review your health plan to make sure your coverage includes international travel. If it does not, it is strongly recommended that you purchase appropriate medical travel insurance to cover unforeseen medical/health incidents during your stay in Canada.



## VACCINES

It is recommended that all visitors receive a vaccine against influenza at least two weeks before arriving in Vancouver.

For more information on vaccines and other medical issues, visit the Public Health Agency of Canada website at [phac-aspc.gc.ca](http://phac-aspc.gc.ca).

## DIALYSIS SERVICES

Visitors requiring hemodialysis services during their stay are strongly advised to book them well in advance of their trip. Contact the Providence Health Care renal program at **1 604 806 9034** or [mdonnelly@providencehealth.bc.ca](mailto:mdonnelly@providencehealth.bc.ca). Requests must be submitted by January 15, 2010.

## NON-SMOKING POLICY

The Vancouver 2010 Paralympic Winter Games are smoke- and tobacco-free. Smoking is prohibited within indoor venues and smoking outdoors is restricted to designated areas.

**Tip** St. Paul's Hospital is the Games-designated spectator hospital. In case of an emergency, please call **9-1-1** or visit [vch.ca/facilities/hospitals/](http://vch.ca/facilities/hospitals/) for a complete list of hospitals.