

## Improving Flow Measurement Using PLC Based Flow Computing

Jim Ralston & Scott Monton  
ProSoft Technology<sup>®</sup>, February 2008

### Introduction

**This paper explores the use and benefits of embedding hydrocarbon flow computer technology into programmable logic controllers (PLCs) for integrated measurement, control, and communications. Accurate measurement of hydrocarbon gases and liquids using industry measurement standards is vital for process control systems, leak detection, and the transfer of product between two parties, more commonly known as custody transfer. As the complexity and scale of energy systems increase, automation technologies become more important for production efficiency and controlling costs. Process control engineers now have new innovative automation technologies for flow measurement, control and data management.**

### A Brief History of Flow Measurement

The need to accurately measure flow (how much gas or liquid has travelled from point A to B) originated many years ago when those purchasing energy (i.e. oil, gasoline, natural gas) questioned the accuracy of the invoices they received from the sellers. This led engineers to develop mechanical flow meters using paddlewheel and propeller techniques in the pipeline to "count" the amount of flowing material. Unfortunately, these systems weren't very accurate and were prone to mechanical breakdown, but at least the buyer and seller could agree to abide by their numbers.

As technology advanced, flow measurement methods expanded to include more accurate and reliable techniques such as magnetic field, positive displacement, and ultrasound. However even with this improved technology, true flow calculation needed to take into account other measurements and conditions. To calculate *true* flow, temperature, pressure, pipe diameter and material purity all need to be taken into account. Because these attributes are dynamic (changing frequently over time), a way to continuously measure these variables and then calculate flow was required. The flow computer was invented precisely for this purpose.

Flow computers were designed to monitor flow data from flow meters and collect information from other sensors such as temperature, pressure, density and chemical analyzers. They processed the data using standard based algorithms to calculate mass or volume flow. Often the flow computers were installed in remote areas where LACT (leased automated custody transfer) units are located such as offshore oil rigs, pipelines, tank farms and compressor stations. The resulting flow information was either displayed or transmitted into a computer system.

As energy systems grew and telecommunications advanced, distributed control systems became more practical. This required the collection and transmission of flow information from the pipeline to a central collection point. Remote telemetry units (RTUs) were used to store and transmit flow information as part of a remote Supervisory, Control and Data Acquisition (SCADA) network. The RTU and SCADA network typically used the common Modbus protocol because of its popularity and multi-point (polled) architecture. Finally, PLCs were often

installed to handle the electrical control of valves and compressors, and to safely shut down processes during emergencies (see figure 1).

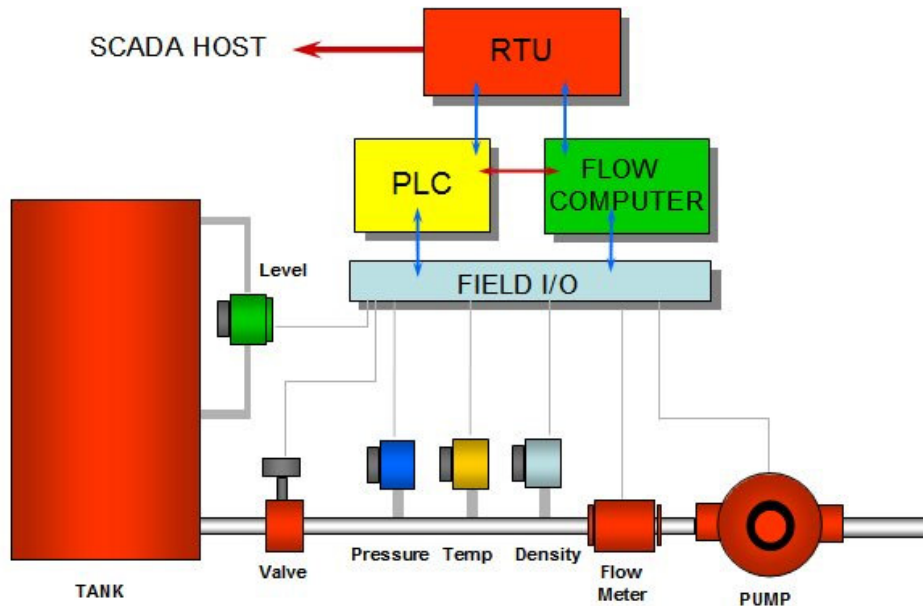

Figure 1: Typical Flow Computer, PLC and RTU System

Today, measuring flow is often accomplished by installing a flow computer to several meter runs and then feeding the information to an RTU. The PLC often needs the same sensor information as well, thus complicating wiring design. While this is effective, it requires integration and wiring of many field devices, thus increasing design time, equipment costs and installation labor, and decreasing system reliability as there are many potential points of failure.

Additionally, stand-alone flow computers are relatively expensive and often limited to only a few meter runs, further increasing costs.

## The Integrated Flow Measurement Solution

PLC technology has significantly improved to support many functions well beyond discrete control and simple data collection. Modern PLCs include many process control functions (such as Process Identifier (PID) loops and recipes) while offering a broad range of communication options and data management tools. This has led many to now refer to PLCs as Programmable Automation Controllers or PACs. The key is that PLC processor power, near real-time I/O speed and flexible networking options makes the PLC platform ideal for just about any challenging industrial application including accurate flow measurement.

However while the PLC platform offers excellent performance, its programming is optimized for sequential control. Burdening the PLC program with complicated calculations (such as flow algorithms) is not good practice especially when multiple meter runs are required. This presents a challenge for using PLCs as complete flow measurement solutions.

One approach to solve this problem is to embed the flow computer function in a PLC module providing an integrated PLC, RTU and flow computer solution. There are several advantages to this approach.

First, the flow computer module can use its own onboard, high speed processor for flow calculations and memory for data archiving. This approach does not burden the PLC processor no matter how many meter run calculations are occurring.

Second, the module can read the input information (flow meter, pressure, temperature, etc.) directly from the PLC over its high speed backplane. This means that the PLC program not only manages the I/O for other processes (such as valve control and alarm monitoring) but also gives the flow computer module access to this information at high speeds.

Thirdly, the PLC can read the flow measurement data directly as I/O register information. The PLC ladder program can then use this information for alarms and controlling process loops.

Finally, the archived data within the flow computer module's memory is available to the SCADA network via the Modbus protocol. This functionality is ideal for hybrid PLC, Distributed Control Systems (DCS) and SCADA systems offering an easy approach to technology migration.

The resulting system combines all standard functions into one platform, thus simplifying design and reducing installation time, while offering flexible communications options (see Figure 2).

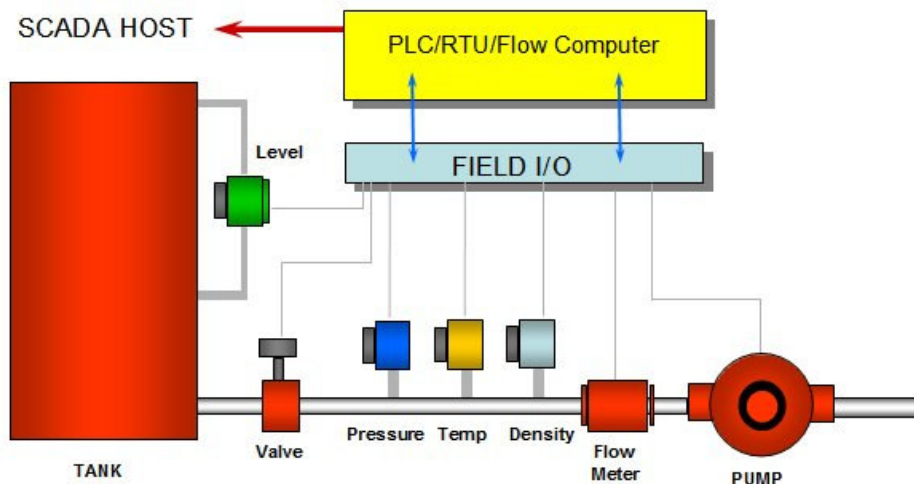

Figure 2: Integrated PLC, RTU and Flow Computer Solution

## Flow Computer Standards and Certifications

As with traditional flow computers, flow computer PLC modules must also comply with hydrocarbon calculation standards to ensure accuracy and to satisfy custody transfer requirements. Standards are important because they define the flow calculation algorithms and provide a common, unbiased measurement method which all parties can agree to upfront. The use of standards therefore greatly reduces custody transfer disputes and provides an easy way of doing business with multiple parties.

As a means of addressing these issues the following standards organizations responsible for petroleum measurement were created: AGA (American Gas Association), API (American Petroleum Institute), GPA (Gas Processors Association), ISO (International Standards Organization), OIML (Organization Internationale de Métrologie Légale, or International Organization of Legal Metrology) and many others.

The AGA and API are the oldest and most widely recognized hydrocarbon standards organizations in North America and publish many standards including AGA 3, 7, and 8, and API 2540.

While AGA and API publish many standards, neither association tests or certifies flow computer devices. In fact, certification is not necessarily a requirement as many producers and consumers will periodically field test the transfer system to ensure accuracy. However, certification may be required due to local regulations or agreement by transfer parties and is often required by law for some classes of transactions.

Certifications are issued by testing organizations, groups of people who evaluate devices submitted for their compliance with those standards requested in the submittal or mandated by law. Such organizations are typically either government regulatory agencies or non-profit companies whose reports are accepted by such agencies. Such organizations include Measurement Canada (a branch of Industry Canada, a ministry of the Government of Canada), UL (Underwriters Laboratories Inc., accepted in most places worldwide), and LNE (Laboratoire National de Métrologie et d'Essais, accepted by several European countries).

#### Practical Benefits for Today's Energy Systems

Embedding the flow computer function into a PLC platform offers many process and financial benefits. Cost savings are immediately evident because PLCs are typically already part of the control system and the embedded PLC module is often thousands of dollars less than a traditional external flow computer.

Most PLC based systems support eight to sixteen meter runs while traditional flow computers may be limited to as few as four. Space savings also are evident as special cabinets or panels are not required to house the flow computer, just an open slot in the PLC.

Backplane communications provide easy integration of sensor I/O, without the need to match fieldbusses, protocols and interfaces to the flow computer. Because PLCs offer a very wide range of I/O options, the sensor wiring and interfacing are simple. There are no special requirements to match the sensors to the flow computer interfaces saving time and expense. Reducing the number of field devices has direct impact on installation time and labor costs as there are fewer devices to install.

Perhaps the most significant benefit of using an in-rack flow computer is the seamless communications provided directly to the PLC platform. Most PLCs now support both Ethernet TCP/IP communications and many serial protocols. Once the flow information is made available to the processor, the network has full access to this data. Remote SCADA, HMI, data collection, historian and maintenance applications can easily access this information, providing very flexible and economical communications. Some flow computer modules also provide Modbus ports for direct connection to Modbus flow meters or as slave connections to legacy SCADA systems.

## PLC Flow Computers in Action

### EnCana's State-of-the-Art Flow Monitoring System

DPH Focus Engineering (DPH) of Calgary, Alberta Canada provides turnkey oil and gas plant automation and process control engineering. In the early 1990's EnCana, Canada's largest oil and gas company, approached DPH about improving production monitoring to better manage their energy resources.

Encana and DPH started out by assessing the flow measurements that were in use. EnCana was using mostly manual collection methods such as chart recorders for recording flow information and then compiling flow totals. As DPH investigated more sophisticated methods, they discovered that EnCana had a number of Allen-Bradley PLCs installed at key monitoring and control points. Intrigued with leveraging this installed base, DPH located ProSoft Technology, the pioneer of PLC-based flow computing technology. The initial product was limited in functionality, but offered much promise.

Over the years, DPH worked closely with Prosoft Technology to expand features and tailor the in-rack flow computer to solve EnCana's flow measurement challenges. DPH was not only an early adopter of this technology, but shaped the development and commercial success of the PLC-integrated flow computer.

Today DPH Focus Engineering, on behalf of Encana, has incorporated the PLC based flow computer technology in many different applications at hundreds of locations throughout Alberta, Canada. The technology is in use in pipelines, well heads, satellite (clustered) wells, compressor stations and processing plants (example monitoring display shown in Figure 4).

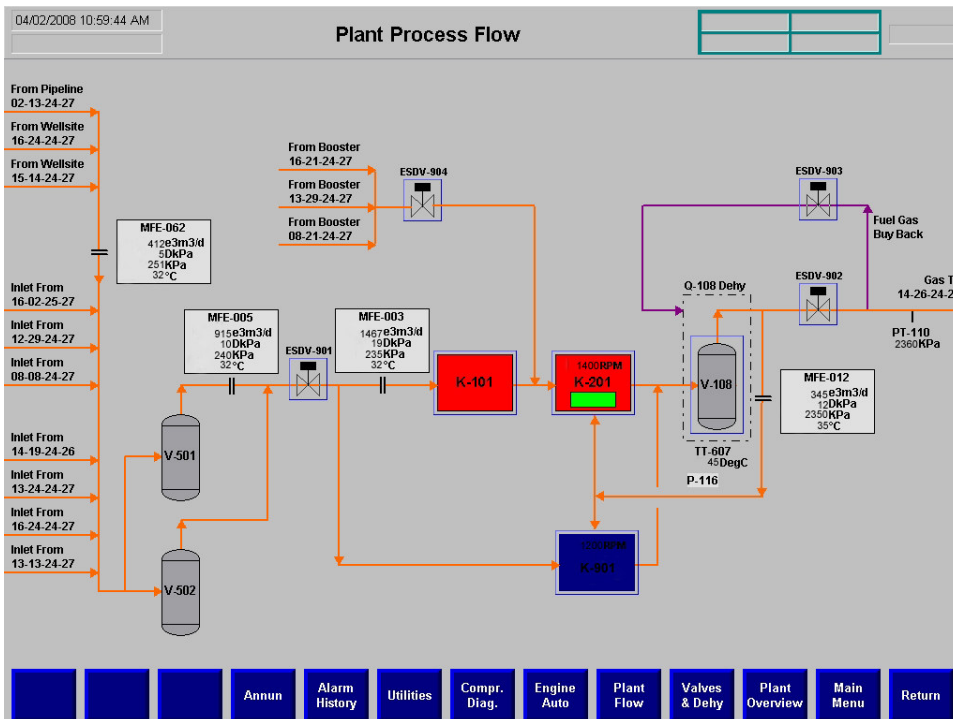

Figure 3: EnCana Plant Process Flow Monitoring Screen

EnCana's gathering system is a compilation of many business units. Various SCADA hosts are encountered within and across the business units. Because the embedded flow computer module has Modbus connectivity, the flow information is easily transmitted over EnCana's extensive SCADA network. Using a combination of licensed RF, license-free wireless and telecommunications, the reliable flow information is consistently available for operation and management staff.

The calculated flows and volumes are constantly relied upon for volume balancing, plant control, well testing, leak detection and market-drive production control. EnCana is now able to have up to the minute knowledge of energy inventories and make real-time decisions on production/transmission based on energy demand. The integrated flow computer's flexibility, proven reliability and accuracy are keys to maintaining a strong link for all levels of EnCana.

### ***Camisea Peruvian Natural Gas Pipeline System***

A large natural gas field was discovered in the Camisea region of Peru in late 1980s. The field promised to be a tremendous energy resource and boon for the Peruvian economy. However, the field was hundreds of miles away from the nearest port and deep in the thick Amazon jungles of the Malivinas rain forest.

The Camisea gas field represented a major engineering and construction challenge. The goal was to build two pipelines to carry natural gas and liquid gas to processing plants located at major ports. Years of planning and development gave birth to the Camisea Natural Gas and Natural Gas Liquid Transportation Systems (see Figure 4), but remote control and monitoring of the pipelines were crucial for success.



Figure 4: Camisea Natural Gas Pipeline System



---

ISI-Solutions, an experienced system integration and engineering firm, was hired to design the controls and communications of the pipelines. After studying various approaches, they settled on the Allen-Bradley ControlLogix platform. The ControlLogix Programmable Automation Controller (PAC) was ideal for automated controls along the remote pipelines and for flexible communications.

One of the key features of the ControlLogix was the availability of the ProSoft Technology Flow Computer Module. The in-rack flow computer technology reduced integration time and ensured compatibility within the Allen-Bradley architecture. The module also provided easy integration into the SCADA system.

Today, the Camisea pipeline system consists of dual pipelines carrying liquid and natural gas from the Camisea natural gas field to processing stations and shipping ports along the coastline. The liquid and gas pipelines transverse 330 miles side by side and then the natural gas pipeline extends another 120 miles up the coastline. The system includes four pumping stations, forty block valve stations, three regulation stations and two control centers.

The critical pipeline controls are dependent on mass flow calculations from four in-rack flow computer modules. After many years of operation, the system is proven to be very reliable and dependable.

#### ***About DPH Focus Engineering***

DPH Focus Engineering is a multi-discipline company offering full engineering, procurement and construction management services. For more information, visit <http://www.dph.ab.ca>.

#### ***About ISI-Solutions***

ISI is a highly specialized service organization providing state-of-the-art information technology and applications for SCADA systems and process automation. For more information, visit <http://www.isi-solutions.com/>.

#### ***About ProSoft Technology***

ProSoft Technology specializes in the development of communication solutions compatible with the large automation suppliers' controllers such as Rockwell Automation and Schneider Electric. ProSoft Technology provides field proven connectivity and communication solutions that bridge between various automation products as seamlessly as if they were all from the same supplier. For more information, visit <http://www.prosoft-technology.com/>.

#### ***About Rockwell Automation***

Rockwell Automation helps manufacturers succeed and grow by providing industrial automation control and information solutions designed to give customers a competitive advantage. For more information, visit <http://www.rockwellautomation.com/>.

#### ***About the Authors***

Jim Ralston has over twenty years of experience with industrial communications and networking. He is currently a Sales Engineer for ProSoft Technology, Inc. Jim resides in Pittsburgh, PA USA and can be reached at [jralston@prosoft-technology.com](mailto:jralston@prosoft-technology.com).

Scott Monton resides in Washington state, USA and is a Sales Engineer for ProSoft Technology, Inc. He can be reached at [smonton@prosoft-technology.com](mailto:smonton@prosoft-technology.com).