

N73-18902

NASA TECHNICAL NOTE

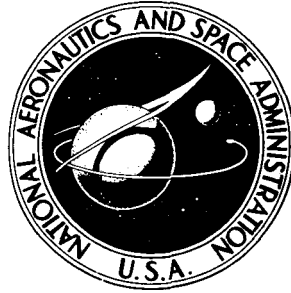

NASA TN D-7083

NASA TN D-7083

**CASE FILE
COPY**

APOLLO EXPERIENCE REPORT -
LAUNCH ESCAPE PROPULSION SUBSYSTEM

by Neil A. Townsend

Manned Spacecraft Center

Houston, Texas 77058

NATIONAL AERONAUTICS AND SPACE ADMINISTRATION • WASHINGTON, D. C. • MARCH 1973

1. Report No. NASA TN D-7083	2. Government Accession No.	3. Recipient's Catalog No.	
4. Title and Subtitle APOLLO EXPERIENCE REPORT LAUNCH ESCAPE PROPULSION SUBSYSTEM		5. Report Date March 1973	
		6. Performing Organization Code	
7. Author(s) Neil A. Townsend, MSC		8. Performing Organization Report No. MSC S-343	
		10. Work Unit No. 914-11-00-00-72	
9. Performing Organization Name and Address Manned Spacecraft Center Houston, Texas 77058		11. Contract or Grant No.	
		13. Type of Report and Period Covered Technical Note	
12. Sponsoring Agency Name and Address National Aeronautics and Space Administration Washington, D.C. 20546		14. Sponsoring Agency Code	
		15. Supplementary Notes The MSC Director waived the use of the International System of Units (SI) for this Apollo Experience Report because, in his judgment, the use of SI Units would impair the usefulness of the report or result in excessive cost.	
16. Abstract <p>The Apollo launch escape propulsion subsystem contained three solid rocket motors. The general design, development, and qualification of the solid-propellant pitch-control, tower-jettison, and launch-escape motors of the Apollo launch escape propulsion subsystem were completed during the years 1961 to 1966. The launch escape system components are described in general terms, and the sequence of events through the ground-based test programs and flight-test programs is discussed. The initial ground rules established for this system were that it should use existing technology and designs as much as possible. The practicality of this decision is proved by the minimum number of problems that were encountered during the development and qualification program.</p>			
17. Key Words (Suggested by Author(s)) * Apollo Launch Escape Propulsion * Solid Rocket Motors * Tower Jettison * Pitch-Control Motor * Launch-Escape Motor		18. Distribution Statement	
19. Security Classif. (of this report) None	20. Security Classif. (of this page) None	21. No. of Pages 29	22. Price \$3.00

CONTENTS

Section	Page
SUMMARY	1
INTRODUCTION	1
COMPONENT CONFIGURATION	2
Pitch-Control Motor	3
Tower-Jettison Motor	4
Launch-Escape Motor	5
OPERATING MODES	6
Normal Launch	6
Abort Capabilities	6
GROUND-BASED TEST PROGRAM	7
Pitch-Control Motor Qualification-Test Program	8
Tower-Jettison Motor Qualification-Test Program	8
Launch-Escape Motor Qualification-Test Program	9
Pitch-Control Motor Qualification and Production Problems	9
Tower-Jettison Motor Qualification and Production Problems	10
Launch-Escape Motor Qualification and Production Problems	11
PAD-ABORT TEST PROGRAM	13
Apollo Pad Abort 1 Mission	13
Apollo Pad Abort 2 Mission	13
LITTLE JOE TEST PROGRAM	14
SATURN AND APOLLO UNMANNED FLIGHT-TEST PROGRAM	21
MANNED-FLIGHT PROGRAM	22
RESULTS	22
CONCLUDING REMARKS	24

TABLES

Table		Page
I	SELECTED DESIGN CHARACTERISTICS OF LES MOTORS	2
II	LITTLE JOE II FLIGHT PROGRAM OBJECTIVES	
	(a) LES launch-vehicle qualification	15
	(b) Apollo A-001 mission transonic abort at high dynamic pressure.	16
	(c) Apollo A-002 mission abort at maximum dynamic pressure . . .	16
	(d) Apollo A-003 mission high-altitude abort	18
	(e) Apollo A-004 mission abort in the power-on tumbling boundary region.	19
III	APOLLO LES QUALIFICATION FLIGHTS	22

FIGURES

Figure		Page
1	Apollo launch escape system	2
2	Pitch-control motor	3
3	Tower-jettison motor	4
4	Launch-escape motor	
	(a) Motor	5
	(b) Igniter	6
5	Major events of Apollo PA-2 mission	14
6	Major events of Apollo A-001 mission	20
7	Major events of Apollo A-002 mission	20
8	Major events of Apollo A-003 mission	20
9	Major events of Apollo A-004 mission	20
10	Apollo BP-13.	21
11	Major events of Apollo AS-101 mission	21
12	Major events of Apollo AS-102 mission	21

Figure		Page
13	Mission-abort points in relation to Saturn launch-vehicle flight envelope	23
14	Test region and abort points for the Apollo A-004 mission	23

APOLLO EXPERIENCE REPORT

LAUNCH ESCAPE PROPULSION SUBSYSTEM

By Neil A. Townsend
Manned Spacecraft Center

SUMMARY

The Apollo launch escape propulsion subsystem contained three solid-propellant rocket motors: the launch-escape motor, the tower-jettison motor, and the pitch-control motor. The launch-escape motor, the main motor in the launch escape system, had a thrust of 155 000 pounds and was capable of moving the command module away from and out of the path of the remaining portions of the launch vehicle if a launch-vehicle malfunction occurred and an abort was required. The tower-jettison-motor function was to separate the launch escape system from the command module before deployment of the command module parachutes if an abort occurred. The tower-jettison motor also was used to remove the launch escape system away from and out of the path of a normally functioning launch vehicle. The pitch-control motor was essential to establish a safe trajectory of the activated launch escape system. The design, qualification, and testing of the launch escape system components were completed during the years 1961 to 1966 and were remarkably free of failures.

INTRODUCTION

The Apollo launch escape system (LES) was designed to provide a positive means of crew escape if booster failure occurred during the initial phase of launch. The system had to achieve sufficient altitude for deployment of the command module (CM) parachutes and to ensure safe lateral separation. Lateral separation was achieved by firing simultaneously the pitch-control motor and the launch-escape motor for low-altitude aborts. The pitch-control motor was not required for high-altitude aborts. The system is no longer required after second-stage ignition and is jettisoned after verification of ignition.

The purpose of this report is to identify those problems that were encountered in the LES propulsion components program. Where possible, an explanation is made of how these problems might be avoided in any future program.

COMPONENT CONFIGURATION

The pitch-control motor, the tower-jettison motor, and the launch-escape motor constituted the propulsion components of the LES, and these motors provided trajectory shaping, LES-jettison capability, and primary propulsion, respectively. Also, the LES (fig. 1) included the Q-ball assembly, the launch-escape tower canard system, the structural skirt, the tower structure, the tower and CM separation system, the forward-heat-shield separation and retention system, and the boost protective cover. Selected design characteristics of the LES motors are given in table I.

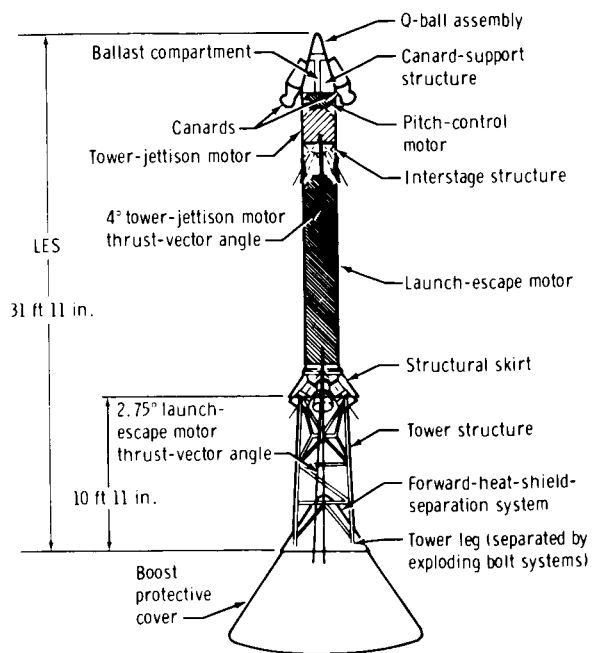

Figure 1. - Apollo launch escape system.

TABLE I. - SELECTED DESIGN CHARACTERISTICS OF LES MOTORS

Item	Pitch-control motor	Tower-jettison motor	Launch-escape motor
Weight, lb	51	535	4850
Length, in.	22.00	55.62	185.57
Diameter, in.	10.51	28.00	53.66
Thrust level at sea-level pressure, lb	≤4000	31 200 to 36 000 (140° F) ^a (average thrust)	≤200 000 (120° F) (maximum vacuum thrust)
		29 400 to 33 900 (70° F) (average thrust)	^b ≥147 000 (70° F)
		28 000 to 32 400 (20° F) (average thrust)	≥121 000 (20° F) (minimum thrust)
Thrust-rise time from application of firing current to reach 90 percent of maximum, msec	60 to 120 (to reach 80 percent of maximum)	75 to 150	50 to 120
Total impulse at sea-level pressure, lb-sec	1750 (70° F) (+3 percent) ^c	35 900 to 37 700 (140° F) 35 800 to 37 600 (70° F) 35 700 to 37 500 (20° F)	515 000 (70° F) (minimum) ^d
Satisfactory performance after uniform soak temperatures, °F			
Maximum, °F	140	140	120
Minimum, °F	20	20	20

^aTemperatures in parentheses are propellant-grain temperatures.

^bAverage thrust between 0.12 and 2.0 seconds at a pressure altitude of 36 000 feet.

^cCapability after modification from 1550 to 3000 lb-sec.

^dMinimum delivered total impulse between 0.12 and 2.0 seconds + 233 064 lb-sec.

Pitch-Control Motor

The combustion chamber was the major structure of the pitch-control motor (fig. 2). The outside wall of the combustion chamber had provisions for mounting the motor horizontally within the canard-support enclosure. The combustion chamber had three basic parts: a cylinder, a forward closure-dome assembly, and an aft closure-dome assembly.

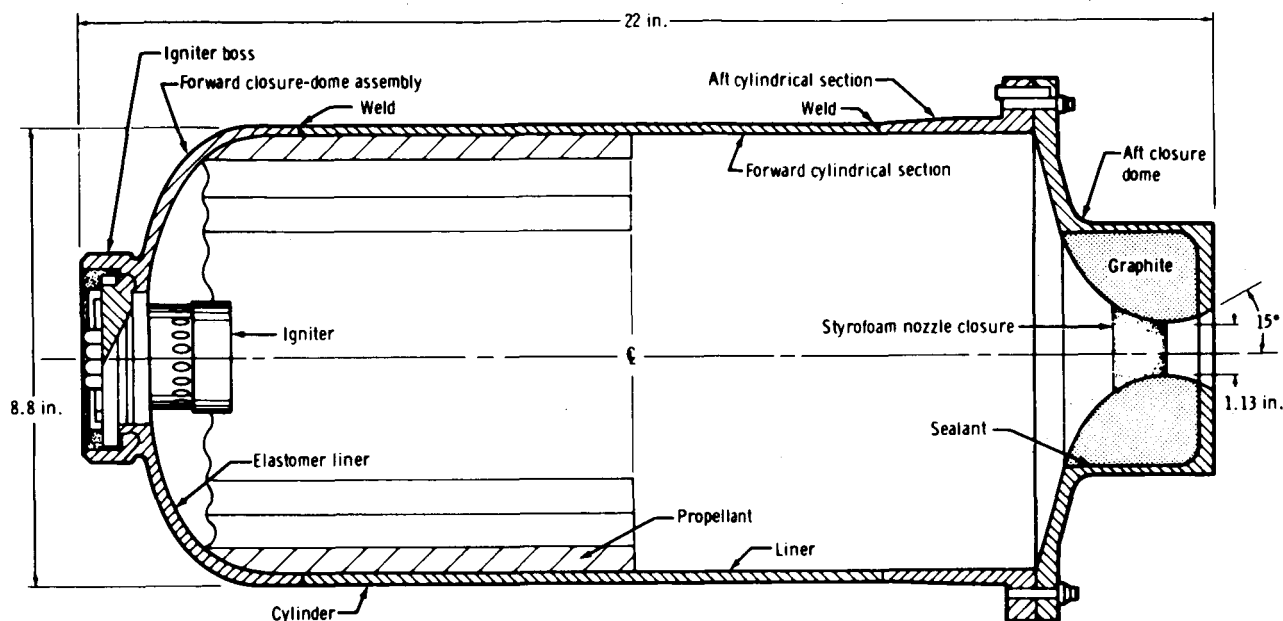

Figure 2. - Pitch-control motor.

The solid-propellant grain of the pitch-control motor was of a 14-point internal-burning star configuration. The solid-propellant grain (approximately 8.9 pounds) was cast directly against the combustion chamber liners. In the original LES mission requirements, it was specified that the pitch-control motor must be suitable for modification so that a total impulse of 1550 to 3000 pound-seconds could be provided without major redesign, redevelopment, or requalification. The pitch-control-motor contractor met this design requirement by varying the propellant-grain length; the addition of auxiliary materials such as grain supports or inert slivers was not needed. Ultimately, in Apollo mission requirements, a total impulse of 1750 pound-seconds was prescribed; therefore, the solid-propellant grain length was approximately 8.2 inches. The maximum solid-propellant grain length that was used during development was approximately 15.9 inches.

The solid-propellant grain was ignited by means of an igniter assembly that consisted of a pellet-basket-type igniter, two pressure taps, and two pyrotechnic igniter cartridges. Each pyrotechnic igniter cartridge consisted of a booster charge and an Apollo standard initiator (hot-bridgewire-type initiator). The pyrotechnic igniter cartridges of the pitch-control motor were identical to the pyrotechnic igniter cartridges that were used in the launch-escape motor and could be installed at the launch pad.

Tower-Jettison Motor

The tower-jettison motor had two major parts: the combustion chamber and the interstage structure (fig. 3). The combustion chamber and interstage-structure assembly were 26 inches in diameter, were 55.6 inches in length, and weighed 527 pounds.

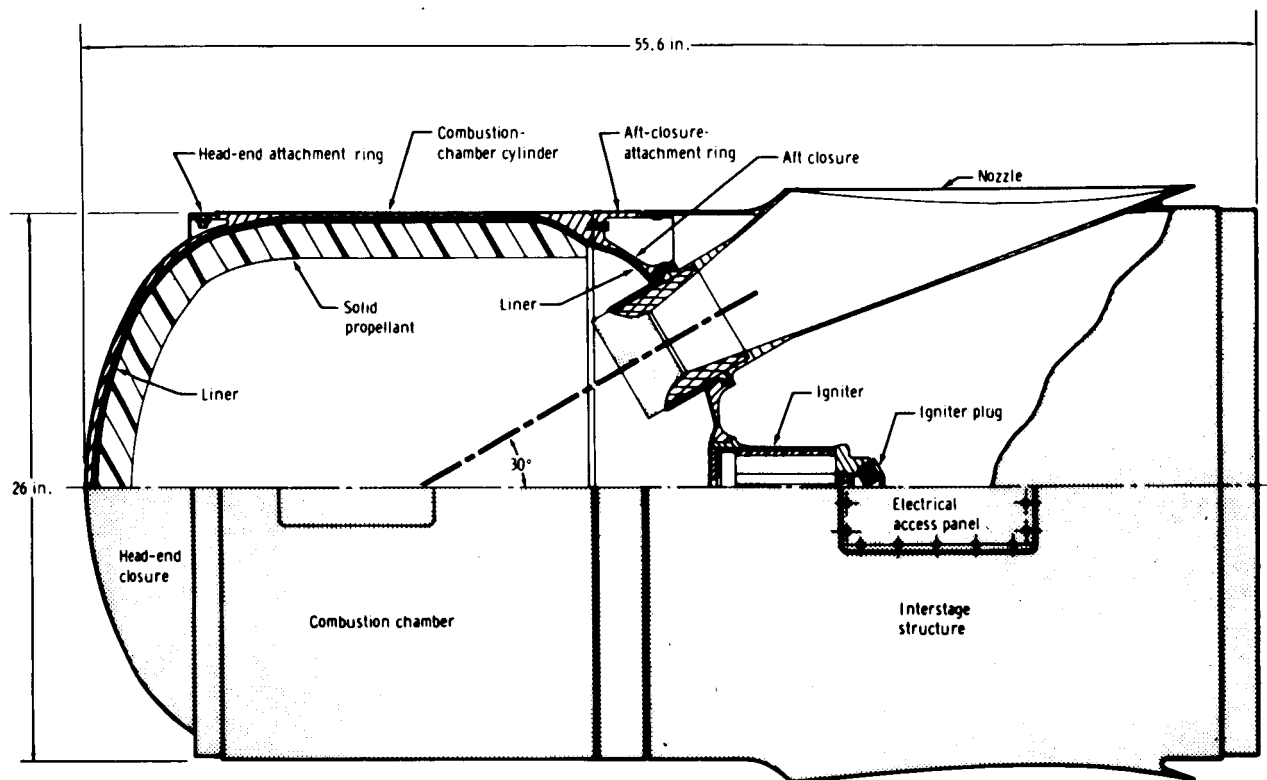

Figure 3. - Tower-jettison motor.

The interstage structure, designed and developed as an integral part of the tower-jettison motor, was used to attach the tower-jettison motor to the launch-escape motor. The 90.3-pound cylindrical interstage structure had a diameter of 26 inches and a length of 30 inches.

The two exhaust nozzles of the tower-jettison motor were bolted to the aft closure of the combustion chamber (fig. 3). The nozzles were submerged in the combustion chamber and extended through the interstage structure wall.

The solid-propellant grain of the tower-jettison motor was of a 10-point, double-web, internal-burning star configuration. This composite solid-propellant grain, which weighed approximately 205 pounds, was cast directly against the chamber liner (fig. 3). The solid-propellant grain did not require the addition of such auxiliary material as grain supports or inert slivers to meet the design objectives.

An igniter assembly was used to ignite the solid-propellant grain of the tower-jettison motor. The igniter assembly consisted of the igniter combustion chamber, the pressure-take-off port, the pellet-container assembly, and the igniter solid-propellant grain.

The main charge of the igniter assembly, a composite solid-propellant igniter grain, consisted of approximately 1.83 pounds of the same type of propellant that was used in the tower-jettison motor. The propellant was cast in a liner tube that was composed of a paper-base phenolic resin. The cast grain was inserted in the igniter case and was bonded in place. The igniter assembly was ignited by means of redundant (two) pyrotechnic igniter cartridges.

Launch-Escape Motor

The case assembly of the launch-escape motor (fig. 4(a)) was made of heat-treated steel and included a cylindrical mounting flange at the forward end for use in mounting the tower-jettison motor (fig. 1). The aft closure dome of the launch-escape motor was made of heat-treated high-strength steel and was attached to the case assembly by means of a bolted flange. The dome contained provisions for attachment of the four fixed-exhaust nozzles, for mounting of the motor-case assembly, and for mating of the dome with the structural skirt.

Four exhaust nozzles were secured to the aft closure dome. Off-sizing of the respective exhaust-nozzle throat diameters, as was done on the tower-jettison motor exhaust nozzles, provided the means for effective thrust-vector deflection from the mean geometric motor centerline.

The solid-propellant grain of the launch-escape motor had an eight-point, internal-burning star configuration. The motor was ignited by means of an igniter assembly (fig. 4(b)). The igniter assembly was mounted on the forward end of the motor-case assembly and was concentric with the motor centerline. The igniter assembly contained a booster charge propellant charge and a main propellant charge. The booster charge was composed of boron and potassium nitrate; the main propellant charge was of the same type as the launch-escape motor propellant.

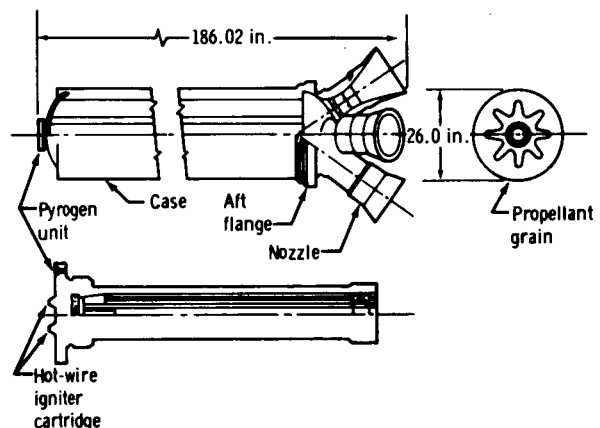

(a) Motor.

Figure 4. - Launch-escape motor.

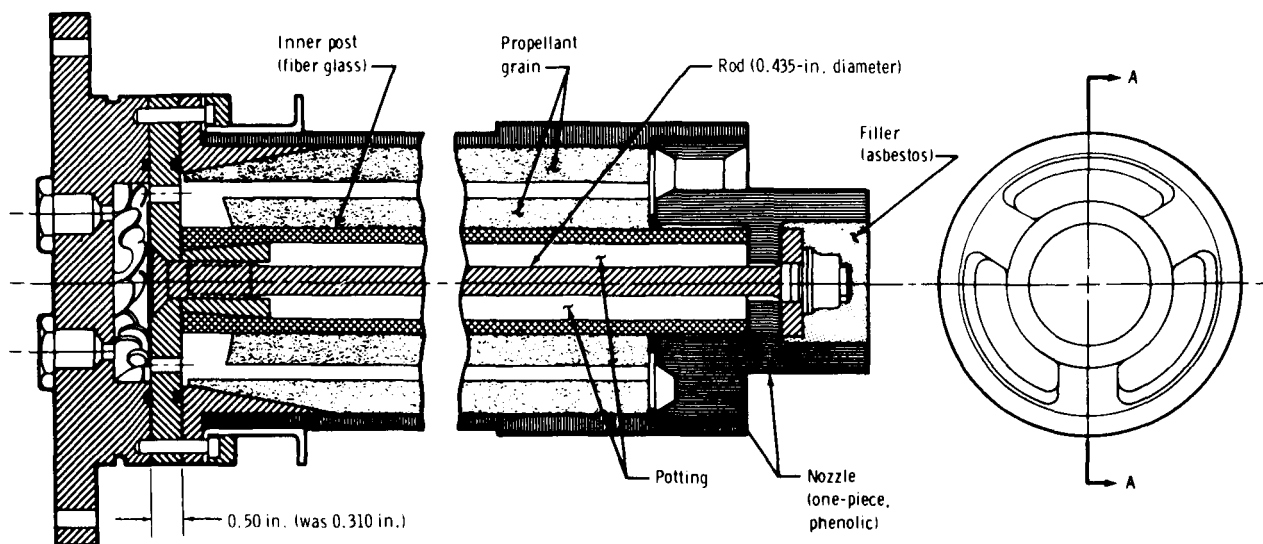

(b) Igniter.

Figure 4. - Concluded.

OPERATING MODES

Normal Launch

During a normal launch, jettison of the LES (fig. 1) was initiated manually. Normally, the tower-leg explosive bolts and the tower-jettison motor were ignited simultaneously. The LES and the boost protective cover were pulled out of the path of the oncoming launch vehicle. The lateral-separation maneuver ensured a minimum miss distance of 150 feet. For worst-case conditions, the LES could separate and avoid recontact with the launch vehicle. If the tower-jettison motor malfunctioned, the launch-escape motor could be used for the LES jettison without impairing the safety of the crewmen.

Abort Capabilities

The six types of abort capabilities that were considered necessary for the LES were as follows.

Pad escape. - For an abort just before or shortly after lift-off, the LES would have separated the CM from the service module (SM) and the launch vehicle. The CM would have been propelled to an adequate height for proper operation of the CM earth landing system. Sufficient range would be obtained to minimize wind-drift problems. The abort-trajectory plane was fixed nominally in a down-range direction. The minimum-altitude requirement for pad aborts was 3000 feet at apogee.

Low-altitude abort. - The LES was capable of separating the CM from a thrusting launch vehicle at altitudes at which range-safety considerations prohibited termination of launch-vehicle booster-engine thrust; that is, until approximately 40 seconds after lift-off.

Abort at high dynamic pressure. - The LES had the capability to function at the maximum dynamic pressure that was expected during launch. The abort would be initiated before structural breakup of the launch vehicle.

Abort below 100 000 feet altitude. - Transition altitude was approximately 100 000 feet. An abort could be initiated either manually or automatically by means of an electrical signal that originated from the launch-vehicle emergency detection system. If an abort signal occurred, the launch-escape motor, pitch-control motor, and CM-to-SM tension-tie pyrotechnics would be ignited simultaneously. The pitch-control motor and the launch-escape motor would provide thrust for approximately 0.6 and 4.0 seconds, respectively. The pitch-control motor could produce a large pitching moment of relatively short duration. The large pitching moment would increase the range capability for pad aborts and would increase lateral separation from the flightpath of the launch vehicle for aborts at higher altitudes. At 42 seconds after lift-off, the pitch-control motor would be deactivated, either automatically by a timer-controlled relay or manually by a crewman-operated switch.

Subsequent to an 11.0-second delay after abort initiation, the canards would be deployed to reorientate the LES and the CM in the heat-shield-forward attitude. Then, after a 3.0-second delay, or after descent to an altitude of 25 000 feet, the LES and the docking mechanism would be jettisoned by means of simultaneous ignition of the tower-jettison motor, the LES tower-leg explosive bolts, and the docking-mechanism pyrotechnics. The boost protective cover, which is attached to the LES tower structure, would be jettisoned with the LES.

Abort above transition altitude. - At altitudes greater than 100 000 feet, the crewmen would use the reaction control system of the CM to provide a positive pitching moment for the LES and CM. The canards would be deployed 11 seconds after abort initiation, and subsequent events would be similar to those described in the preceding paragraph.

Maximum abort altitude. - The maximum altitude for an LES abort was compatible with the completion of launch-vehicle second-stage ignition, with the separation of jettisoned components, with the achievement of a launch-vehicle dynamic pressure, and with the resulting low drag that facilitated the use of the SM propulsion system. The parameters that were established as maximal for the operation of the LES were an altitude of 320 000 feet, a Mach number of 8.0, and a dynamic pressure of 0.5 to 1.0 lb/ft².

GROUND-BASED TEST PROGRAM

The LES qualification-test program consisted of environmental testing and static test firing of LES pitch-control, tower-jettison, and launch-escape motors. The static

test firings consisted of firing the LES solid-propellant test motors after the propellants had been stabilized at selected temperatures. All static test firings were accomplished with motors that had prefire solid-propellant temperatures of 20°, 70°, or 120° F. These temperatures represented minimum, nominal, and maximum expected motor temperatures. All LES solid-propellant motors were static test fired at a nominal pressure of 14.7 psia.

Pitch-Control Motor Qualification-Test Program

Environmental testing was conducted on 14 pitch-control motors. The pitch-control motors were divided into five test groups: (1) temperature cycling and vibration testing, (2) temperature cycling and drop testing, (3) accelerated aging, (4) acceleration testing, and (5) temperature-cycle testing. Static test firings were conducted on 17 pitch-control motors, including 10 motors that were used previously in the environmental testing. The pitch-control motors were divided into three groups based on prefire solid-propellant temperatures of 20° F (six motors), 70° F (four motors), and 120° F (seven motors).

During the qualification phase of testing, the pitch-control motor met all environmental and structural-integrity test requirements. Also, the motor met all performance-specification requirements except those for thrust-rise time. Specification requirements for thrust-rise time were a minimum of 0.060 second and a maximum of 0.110 second. One motor that had a thrust-rise time of 0.117 second was static test fired to simulate a failure mode (simulating a nozzle-closure failure). This thrust-rise time was within the specification requirements for the launch-escape motor (a minimum of 0.050 second and a maximum of 0.120 second), thus the deviation was acceptable because the pitch-control motor was ignited concurrently with the launch-escape motor. The pitch-control motor specification was changed to agree with the thrust-rise time of the launch-escape motor.

Tower-Jettison Motor Qualification-Test Program

The static-test-firing phase of the qualification-test program was conducted on 21 tower-jettison motors, including 15 motors that were tested environmentally. The motors were divided into four test groups: (1) temperature cycling, (2) accelerated aging, (3) temperature cycling and impact testing, and (4) vibration testing, temperature cycling, and impact testing. The tower-jettison motors were divided into three groups based on prefire solid-propellant temperatures of 20° F (nine motors), 70° F (five motors), and 120° F (seven motors).

It was noted in tower-jettison-motor specifications that certain performance parameters must be within specific tolerances at the prefire propellant temperatures of 20°, 70°, and 120° F; however, because of conditioning problems, the static-test-firing data were obtained at somewhat different prefire propellant temperatures.

Launch-Escape Motor Qualification-Test Program

The qualification-test program consisted of static firing tests of 20 launch-escape motors. Four types of tests were involved; these tests included firing (seven motors), accelerated aging (two motors), temperature cycling (four motors), and sequential tests (seven motors). The sequential tests consisted of firing seven launch-escape motors that were subjected to a specific sequence of environments. Six motors were each subjected successively to a temperature-cycle test, a drop test, and a firing test. One motor was subjected successively to a vibration test, a temperature-cycle test, and a firing test.

All launch-escape-motor specifications that concerned ballistic performance, environmental testing, and thrust alignment (except for roll-moment testing) were met. The test data indicated that the maximum roll limit of 130 foot-pounds was exceeded for five motors; however, an optical check of the nozzles indicated that the maximum misalignment would result in a maximum roll of no more than 4 foot-pounds. The high roll moments were attributed to test stand load cell measurement errors rather than to a design deficiency.

Pitch-Control Motor Qualification and Production Problems

The maximum combustion-chamber pressure and the maximum thrust of a qualification static-test-fired pitch-control motor were abnormally high for the 20° F prefire-conditioning temperature of the motor. Although the test results indicated that the pitch-control motor had met all specification requirements, an investigation was conducted to determine the cause of the anomaly.

Postfire inspection of the expended hardware revealed that there were two hot spots in the combustion chamber at the forward girth weld. Further inspection of the combustion-chamber interior resulted in evidence of premature solid-propellant burn-out in these areas. A review of the processing and test records indicated that, after radiographic inspection of the motor, a nonconformance report was written to document two solid-propellant cracks. One crack was located midway between the girth weld on the aft end of the combustion chamber, and the other crack was located at the forward girth weld approximately two webs from the area where the hot spots were noted. The Material Review Board decision, based on experience with defects such as these during the development program, was to accept the pitch-control motor without repair. In the opinion of the Material Review Board, these defects (solid-propellant cracks) would not affect ballistic performance materially, whereas repair would necessitate extensive solid-propellant removal. Based on the results of the investigation, the defects at the girth weld propagated along the weld; thus, a large area of solid-propellant unbond was produced during static test firing. The corrective action to prevent a recurrence of this anomaly was to repair all solid-propellant cracks before shipment.

During the drop test of a pitch-control motor that was being subjected to temperature cycling and drop testing before static firing, another failure occurred. The drop test was planned to demonstrate that the motor could be handled safely. The pitch-control-motor solid propellant was temperature cycled by means of successive stabilization at -20°, 140°, -20°, 140°, and -20° F. At the final -20° F condition, the pitch-control motor was positioned with the longitudinal axis vertical and the nozzle

end down and was dropped 4 feet onto reinforced concrete. By inspection of the nozzle hull, it was noted that the graphite insert had moved forward approximately 0.030 inch, breaking the sealant at the graphite-hull upstream interface. This failure caused excessive leakage during the postassembly pressure check, and the motor was rejected for static test firing in accordance with existing qualification plans; therefore, the drop test was considered to be successful because no safety hazard existed after the motor was dropped.

Tower-Jettison Motor Qualification and Production Problems

During static test firing, the thrust-rise times of two tower-jettison motors exceeded the specification. The static test performance of these motors was normal except for a long ignition delay time, which resulted in a prolonged thrust-rise time and total burn time. The cause of these unusually long ignition-delay times was traced to low input current being applied to the initiator bridgewires. The low input current was caused by an improperly used firing harness (ground-support equipment) that connects the igniter cartridges to the ignition circuit (ground-support equipment). A firing current of 5 amperes should have been applied to each of two bridgewires that were attached to each initiator. Instead, the improperly used firing harness resulted in the application of approximately 2.5 amperes of firing current to each of two bridgewires that were attached to each initiator. The motor manufacturer did not have adequate definition of current application requirements to design the wiring harness properly. Clarified instructions were provided and the low-amperage condition was corrected for all subsequent testing by making two special firing harnesses. One of these special firing harnesses was used for static test firings of tower-jettison motors that were assigned to ignition test categories 1 and 3; that is, both ignition categories necessitated duplication of a failed igniter cartridge. The other special firing harness was used for static test firings of tower-jettison motors that were assigned to ignition test categories 2 and 4; that is, both of these ignition categories necessitated normal ignition conditions. The failures of the two tower-jettison motors were a direct result of improperly used ground-support equipment rather than the result of a tower-jettison motor malfunction, and the results were deleted from the performance evaluations.

The thrust-rise time that was obtained from another tower-jettison motor during static test firing exceeded the specification. The static test firing performance of this motor was normal except for an unusually long igniter ignition-delay time, which resulted in prolonged motor ignition-delay, thrust-rise, and total times. A thorough check of the electrical and instrumentation systems led to the conclusion that the proper firing current, igniter-cartridge resistances, and igniter harness were used. The precise cause of this failure could not be determined from the available information. However, possible factors that could have contributed to the malfunction were inert debris from the igniter cartridge, relatively small-diameter flame ports in the igniter case, premature expulsion of the booster powder charge from the igniter cartridge, and deflection of the igniter-cartridge flame by the igniter-cartridge closures into the heat-sink area of the igniter case.

Corrective action to prevent future igniter failures of the types discussed included modification of the igniter assembly to permit a greater tolerance for the debris associated with the igniter cartridge. The diameter of the flame ports in the igniter case was enlarged from 0.375 to 0.500 inch to preclude flame-passage blockage. The

two-layer vinyl-tape cover on the boron/potassium nitrate pellet container was reduced to a single-layer-tape cover to permit easier tape burnthrough. This igniter ignition-delay malfunction occurred during the time that the tower-jettison motor was duplicating a double-failure mode (a failed initiator and a failed nozzle closure), and there is no requirement for successful demonstration with the tower-jettison motor under these conditions. Because the igniter assembly was modified and because a double-failure mode was being duplicated, the test results of the failed motor were deleted from the performance evaluation.

After the completion of the tower-jettison motor qualification-test program, an igniter-test program was conducted to verify that the igniter modifications were successful. This program was completed without any failures.

Failure of the interstage structure of the third tower-jettison motor that was static test fired caused the subsequent destruction of the motor assembly. The failure, which originated at the interstage structure forward and aft attachment rings, was caused by shear failure of the spotwelds that were used to attach the rings to the interstage structure. Because the rings became detached, the solid-propellant motor pulled free from the test stand, impacted on the head-end wall of the test bay, and shattered the motor assembly. During postfire inspection, it was noted that the interstage aft attachment ring was still bolted to the test stand, and the forward attachment ring had remained bolted to the motor aft closure. By examination of the sheared spotwelds on both rings, evidence of inadequate welding was obtained. During subsequent investigation of the spotwelding operation, it was ascertained that improper mating of the components to be welded could have been an important factor that had contributed to the inadequate welds. It was discovered also that one welder had rewelded those welds that did not pass visual inspection. This would have resulted in weld embrittlement and failure at lower stress. These factors led to the conclusion that the integrity of the spotwelds on all of the remaining interstage structures was questionable; therefore, to prevent future failures, the spotwelds of all of the remaining interstage structures were supplemented with high-shear rivets. Also, a procedure was incorporated to proof-load test all interstage structures at 1.15 times the design load, and another solid-propellant tower-jettison motor was added to the qualification-test program to replace the failed motor.

To verify the structural integrity of the redesigned interstage assembly, two interstages were subjected to three cycles of proof loading; then, the two interstages were loaded until failure occurred. Failure was considered to be the point at which interstage-structure deformation continued without a corresponding load increase. The two interstages failed at pull loads of 2.5 and 2.6 times the design loads, respectively. These pull loads were greater than the ultimate-load requirement of 1.5 times the design load. No rivet or spotweld connections failed during the ultimate-load tests. As a result of the successful proof-load and ultimate-load testing, the structural adequacy of the interstage redesign was proven.

Launch-Escape Motor Qualification and Production Problems

Launch-escape motor cases were manufactured in four lots. During the lot 2 acceptance test, one launch-escape motor case failed at 2300 psig during the seventh proof cycle (2400 ± 50 psig). This failure was attributed to a weld defect. This motor

case was being used to verify the adequacy of all the cases fabricated in lot 2. It had been subjected to six proof cycles and the seventh test was to have proceeded to burst pressure when the failure occurred. The failure investigation concluded that, if the case had been subjected to X-ray inspection before the final test, the weld flaw would have been detected. Additionally, the maximum operating pressure was 1800 psia; therefore, the case had shown a safety factor of 1.3. Based on this rationale and because all cases were subjected to X-ray inspection after proof testing, it was concluded that no corrective action was required.

During the lot 3 acceptance test, a launch-escape motor case that was being tested failed at 2270 psig during the third proof cycle (2400 ± 50 psig). Because of this failure, a second motor case was assigned to the lot 3 acceptance test program, and this motor case failed at 2250 psig during the third proof cycle (2400 ± 50 psig). By means of metallurgical examination, it was shown that an unqualified weld wire was used in the manufacture of the lot 3 launch-escape motor cases; therefore, all lot 3 motor cases were rejected, and quality control procedures were imposed on the supplier to ensure that this failure would not occur again.

During production-acceptance static firing of a launch-escape motor, the inner fiber-glass solid-propellant grain support of the pyrogen igniter broke loose from its retention device and exited through the nozzle, striking and breaking off the nozzle exit cone approximately 6 inches from the end. The results of an investigation indicated that the pressure of the motor ignition caused the phenolic plug in the end of the inner fiber-glass solid-propellant grain support to be forced forward, impacting the end of the support and expanding; this could have broken the bond between the pyrogen assembly and the inner fiber-glass solid-propellant grain support (fig. 4(b)).

A decision was made to redesign the igniter to improve the inner fiber-glass solid-propellant grain-support capabilities by making three changes. A tension rod was added in the inner fiber-glass solid-propellant grain support to retain the support if a failure occurred. Lateral displacement of the inner fiber-glass solid-propellant grain support at the aft end during firing of the launch-escape motor was prevented. The total mass of parts was minimized to be consistent with the other two changes.

To verify the structural integrity of the improved igniter under operating conditions, the following test conditions were used.

1. Overtests at extreme temperature conditions
2. Overtests at high igniter-pressure conditions
3. Normal tests of igniters previously exposed to temperature cycling or to vibration conditions
4. Normal tests of igniters during vibration conditions
5. Normal tests of igniters in full-scale launch-escape motors
6. Structural tests to failure (hydroburst tests) of igniter inert components

Test-program results indicated that the improved-design igniter performed satisfactorily under extreme-temperature conditions, high igniter pressures, and within the specification requirements. A minimum design margin of safety of 1.4 was demonstrated in two structural tests. The improved igniter design sustained minor erosion of the outer solid-propellant grain support upstream of the junction with the igniter nozzle. However, the extent of erosion was so slight that the integrity of the igniter was not compromised.

PAD-ABORT TEST PROGRAM

The pad-abort test program was designed to provide a means by which the LES pad-abort capabilities could be demonstrated. The test program involved two flights. On both flights, the LES requirements were to propel an unmanned Apollo-type boiler-plate spacecraft from a launch pad to sufficient height and oriented to the proper attitude so that the spacecraft earth landing system could function properly.

Apollo Pad Abort 1 Mission

The Apollo pad abort 1 (PA-1) mission was the first flight test of an Apollo-type spacecraft. All first-order test objectives of the Apollo PA-1 mission were satisfied. Aerodynamic-stability characteristics of the Apollo escape configuration during a pad abort were determined. The LES and CM configurations were stable during the flight; however, pitch, yaw, and roll were not as predicted during the powered phase of the flight. The capability of the LES to propel a CM to a safe distance from the launch vehicle was demonstrated.

The most significant anomaly of the Apollo PA-1 mission appeared during the postflight investigation. It was discovered that launch-escape-motor exhaust particles had impinged on the CM and had caused soot deposits. As a result of this anomaly, a boost protective cover for the CM was provided on subsequent vehicles.

Apollo Pad Abort 2 Mission

The Apollo pad abort 2 (PA-2) mission, the second pad-abort test, was required because of spacecraft-configuration changes that had been made. These changes included changes in mass characteristics, the addition of a canard subsystem, and the addition of the CM boost protective cover. All objectives of the test were accomplished successfully. The flight sequence of major events for the Apollo PA-2 mission is given in figure 5.

As planned, the launch-escape motor and the pitch-control motor were ignited simultaneously. A moderate positive-roll rate developed at lift-off; this was attributed to the aerodynamic asymmetry of the vehicle configuration. The roll rate did not compromise the success of the mission. The canard surfaces were deployed satisfactorily to destabilize the configuration and to turn the configuration to a main-heat-shield-forward condition at the time of the drogue-parachute deployment. During the turn-around maneuver, the LES and the apex cover were jettisoned successfully.

LITTLE JOE TEST PROGRAM

The Little Joe flight test program consisted of five launches of simulated CM on Little Joe II launch vehicles. The Little Joe II test program was conducted at the White Sands Missile Range, New Mexico.

The primary objectives of the Little Joe II flights were to demonstrate that the LES could safely abort the CM under critical flight conditions, to verify the integrity and reliability of the earth landing system after an abort, and to confirm the structural integrity of the earth landing system and the CM when exposed to critical abort conditions.

The first flight of a qualification-test vehicle was launched on August 28, 1963. A series of four Little Joe II launches was conducted on boilerplates of prototype Apollo spacecraft. The objectives of the Little Joe II test program are summarized in table II, and the major events are shown in figures 6 to 9.

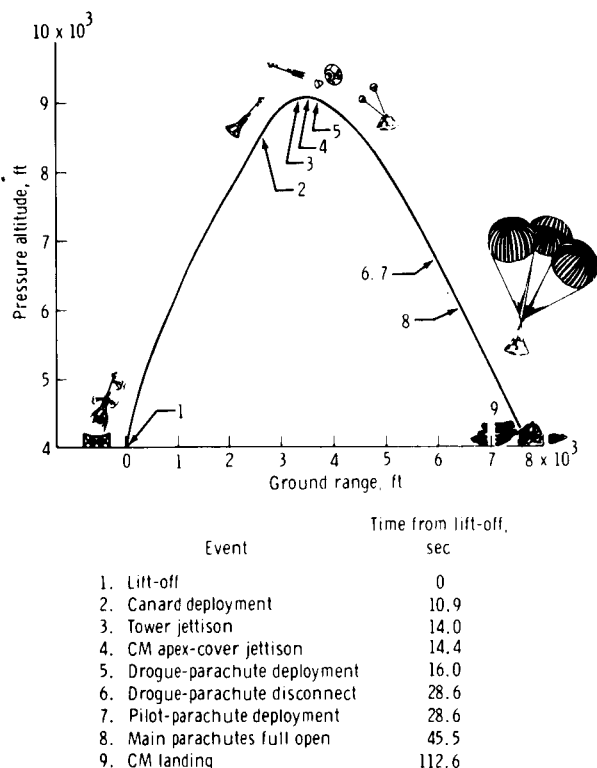

Figure 5. - Major events of Apollo PA-2 mission.

Each of the abort missions resulted in soft landings of the CM boilerplates; this included one unscheduled inflight emergency abort that was caused by a malfunction of the launch vehicle control system. Shortly after lift-off on the Apollo A-003 mission, the Little Joe II launch vehicle began an uncontrolled roll that accelerated as the flight velocity increased. Before second-stage ignition and while still at low altitude, the Little Joe II launch vehicle disintegrated. An unplanned (but successful) low-altitude abort was started 26.3 seconds later, and satisfactory earth landing occurred approximately 4.5 minutes later. Because of the early breakup of the Little Joe II launch vehicle, the high-altitude-test point (120 000 feet) was not achieved, but a successful low-altitude (12 400 feet) abort from a rapidly rolling (approximately 335°/sec) launch vehicle was demonstrated. At the time of the abort, the Mach number, the dynamic pressure, and the altitude were close to Saturn IB and Saturn V nominal-launch-trajectory conditions.

The Little Joe II test series resulted in the qualification of the Apollo LES and the CM earth landing system for manned missions. If the tests had been manned missions, the crewmen would have landed safely.

TABLE II. - LITTLE JOE II FLIGHT PROGRAM-OBJECTIVES

(a) LES launch-vehicle qualification

Development issues	Objectives
Performance	Demonstrate capability to perform the launch trajectory for Apollo A-001 mission ^a Demonstrate ability of launch vehicle to clear the launcher ^a Demonstrate Algol thrust-termination system ^a Demonstrate functional and structural adequacy of ground-support equipment ^b
Integrity	Demonstrate that fins are flutter free ^a Demonstrate structural integrity for Apollo A-001 mission ^a
Procedures	Demonstrate adequacy of the procedure for wind compensation by aiming launcher in azimuth and elevation ^a Evaluate techniques and procedures which contribute to efficient launch operations ^b Evaluate procedures for ground-command abort for application to Apollo A-001 mission ^b
Environment	Determine base pressures Determine base heating Determine flexible body response of total launch vehicle plus payload

^a First-order test objective.

^b Second-order test objective.

TABLE II. - LITTLE JOE II FLIGHT PROGRAM OBJECTIVES - Continued

(b) Apollo A-001 mission transonic abort at high dynamic pressure

LES issues	Objectives
Abort capability	Demonstrate the capability of the LES to propel the CM safely away from the launch vehicle ^a
Stability	Determine aerodynamic stability characteristics of the escape configuration for this abort condition ^a
Structural integrity and performance	Demonstrate the structural integrity of the escape tower ^a
Separation	Demonstrate satisfactory timing sequence in the earth landing system ^a
Recovery with earth landing system	Demonstrate proper operation of the applicable components of the earth landing system ^a Demonstrate proper operation of the CM/SM separation subsystem ^b
Effects induced by environment	Determine aerodynamic loads that are caused by local surface pressure on the CM and SM during a Little Joe II launch ^b

(c) Apollo A-002 mission abort at maximum dynamic pressure

LES issues	Objectives
Abort capability	Demonstrate satisfactory launch escape vehicle (LEV) performance by the use of the canard subsystem and boost protective cover, and verify the abort capability at maximum dynamic pressure with conditions that approximate the limits of the emergency detection system ^a Determine the performance of the LEV in the maximum-dynamic-pressure region ^b

^a First-order test objective.

^b Second-order test objective.

TABLE II. - LITTLE JOE II FLIGHT PROGRAM OBJECTIVES - Continued

(c) Apollo A-002 mission abort at maximum dynamic pressure - Concluded

LES issues	Objectives
Stability	Demonstrate satisfactory power-on stability for abort in the maximum-dynamic-pressure region with conditions that approximate emergency detection subsystem limits ^b Demonstrate satisfactory canard deployment, turnaround dynamics, and main-heat-shield-forward flight stability before LES jettison ^b
Structural integrity and performance	Demonstrate the structural performance with the canard subsystem ^c Demonstrate the structural performance of the boost protective cover during an abort in the maximum-dynamic-pressure region ^c
Separation	Demonstrate satisfactory separation of the LES and boost protective cover from the CM ^b
Separation	Demonstrate satisfactory vehicle separation from the SM at a selected angle of attack ^c
Recovery with earth landing system	Demonstrate satisfactory operation and performance of the earth landing system by the use of reefed dual drogues ^b
Effects induced by environment	Determine the CM pressure loads, including possible plume impingement, in the maximum-dynamic-pressure region ^b Determine the aerodynamic pressure loads on the SM during the the launch phase ^c Obtain thermal effects data on the CM during an abort in the maximum-dynamic-pressure region ^c

^bSecond-order test objective.

^cThird-order test objective.

TABLE II. - LITTLE JOE II FLIGHT PROGRAM OBJECTIVES - Continued

(d) Apollo A-003 mission high-altitude abort

LES issues	Objectives
Abort capability	Demonstrate satisfactory performance of the LEV at an altitude of approximately the upper limit for the canard subsystem ^a
Stability	Demonstrate orientation of the LEV to a main-heat-shield-forward attitude ^a Determine the damping of oscillations in the LEV with the canard subsystem deployed ^b
Structural integrity and performance	Determine the physical behavior of the boost protective cover during launch and during entry from high altitude ^c
Separation	Demonstrate jettison of the LES with the boost protective cover after high-altitude entry ^b
Recovery with earth landing system	Demonstrate performance of the system by the use of the two-point harness attachment for the main parachutes ^c
Effects induced by environment	Obtain data on thermal effects during boost and during impingement of the launch-escape motor plumes on the CM and the launch-escape tower ^c Determine pressures on the CM boost protective cover during launch and high-altitude abort ^c Determine vibration and acoustic environment and response of the SM reaction control system with simulated quads ^c

^a First-order test objective.

^b Second-order test objective.

^c Third-order test objective.

TABLE II. - LITTLE JOE II FLIGHT PROGRAM OBJECTIVES - Concluded

(e) Apollo A-004 mission abort in the power-on tumbling boundary region

LES issues	Objectives
Abort capability	Demonstrate satisfactory performance of the LEV for an abort in the power-on tumbling boundary region ^a
Stability	Demonstrate the capability of the canard subsystem to satisfactorily reorient and stabilize the heat shield of the vehicle in a forward attitude after a power-on tumbling abort ^b
Structural integrity and performance	Demonstrate the structural integrity of the airframe structure for an abort in the power-on tumbling boundary region ^a Demonstrate the structural capability of the production spacecraft to withstand the launch environment ^b
Separation	Demonstrate the capability of the CM forward-heat-shield thrusters to satisfactorily separate the forward heat shield after the tower has been jettisoned by the tower-jettison motor ^b Demonstrate satisfactory separation of the LEV from SM ^c
Recovery with earth	Demonstrate satisfactory operation and performance of the system with a production spacecraft ^c
Effects induced by environment	Determine the static loads on the CM during launch and during the abort sequence ^b Determine the dynamic loading on the CM inner structure ^b Determine the dynamic loads and the structural response of the SM during launch ^b Determine the static pressures imposed on the CM by free-stream conditions and by LES motor plumes during a power-on tumbling abort ^b Obtain data on the structural response of the CM during sequence of operation of the earth landing system ^c Obtain thermal data on the boost protective cover during a power-on tumbling abort ^c Obtain acoustical noise data inside the CM at an astronaut station ^c

^a First-order test objective.

^b Second-order test objective.

^c Third-order test objective.

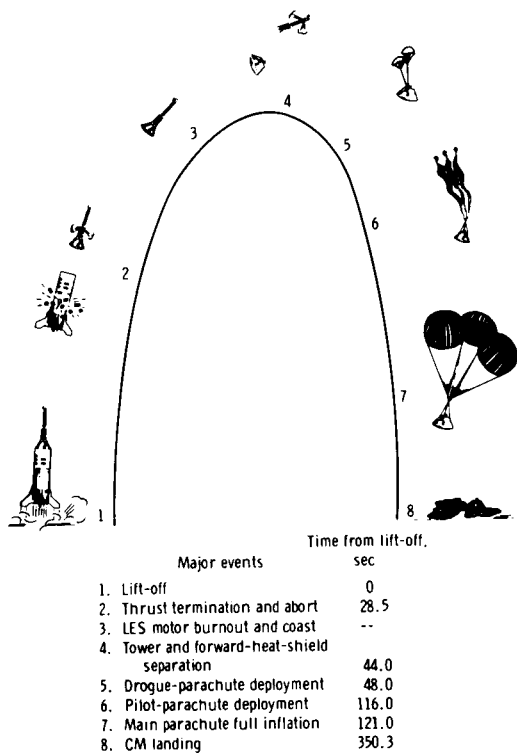

Figure 6. - Major events of Apollo A-001 mission.

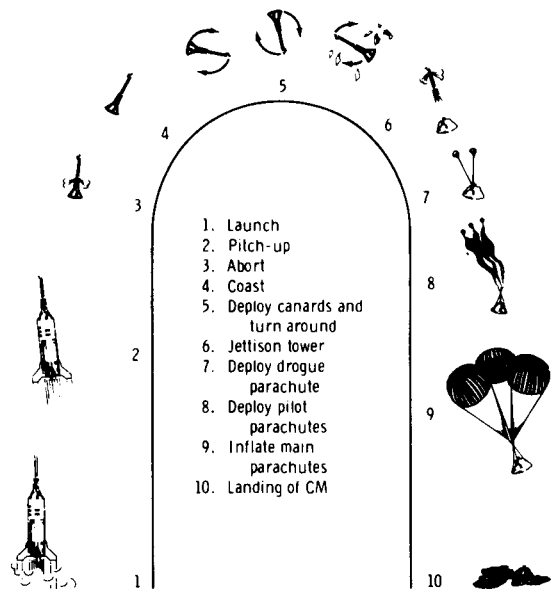

Figure 7. - Major events of Apollo A-002 mission.

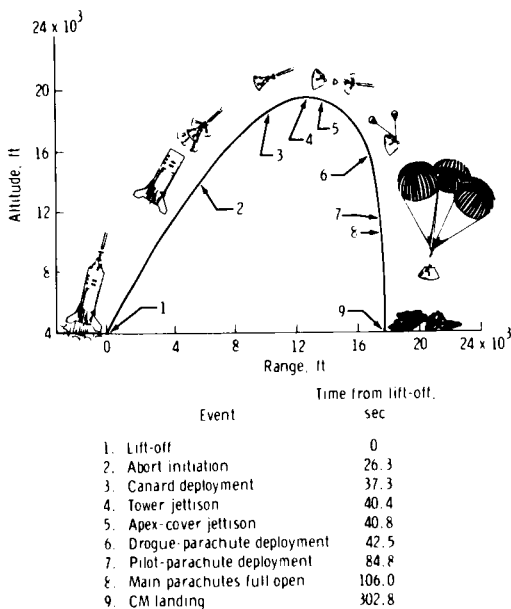

Figure 8. - Major events of Apollo A-003 mission.

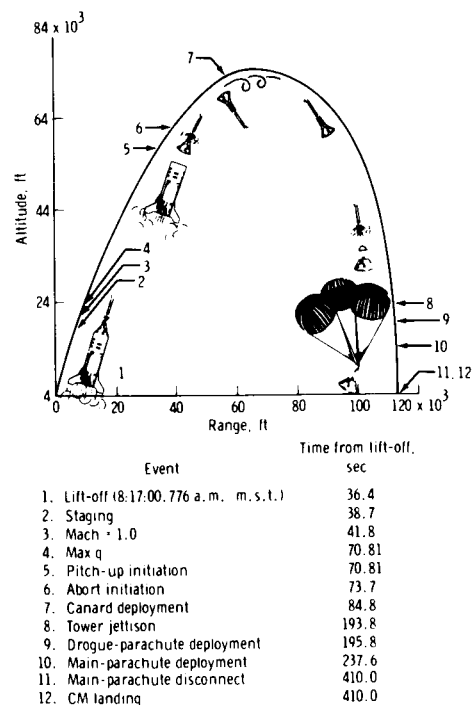

Figure 9. - Major events of Apollo A-004 mission.

SATURN AND APOLLO UNMANNED FLIGHT-TEST PROGRAM

The Saturn flight-test program was conducted on the boilerplate Apollo spacecraft, production-type launch escape systems, and Saturn I launch vehicles (fig. 10). This program was designed to show the compatibility of the Apollo spacecraft system with the Saturn-type launch vehicle. The Saturn flight-test program involved two unmanned missions.

In the first test (AS-101), depicted in figure 11, the normal tower-jettison mode was successfully demonstrated. The launch-escape and pitch-control motors were inert. In the second test (AS-102), depicted in figure 12, the backup mode of tower jettison using the launch-escape and pitch-control motors was successfully demonstrated. There were four unmanned Apollo missions, all of which involved a qualification configuration of the launch escape system, and all of these flights used a normal tower-jettison mode.

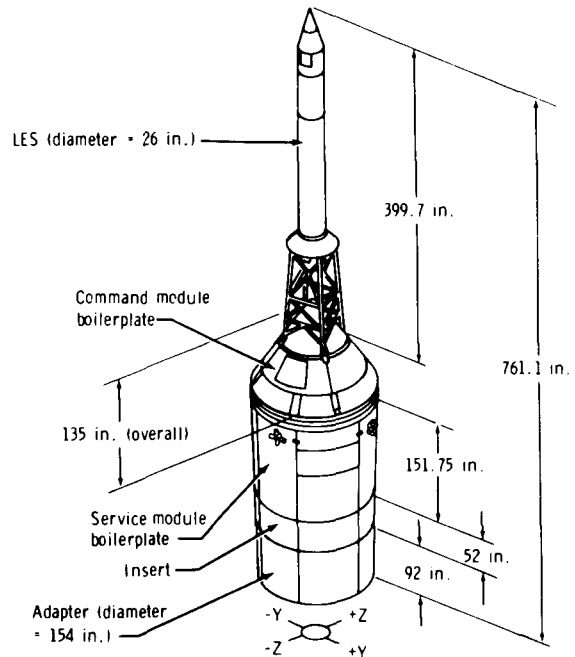

Figure 10. - Apollo BP-13.

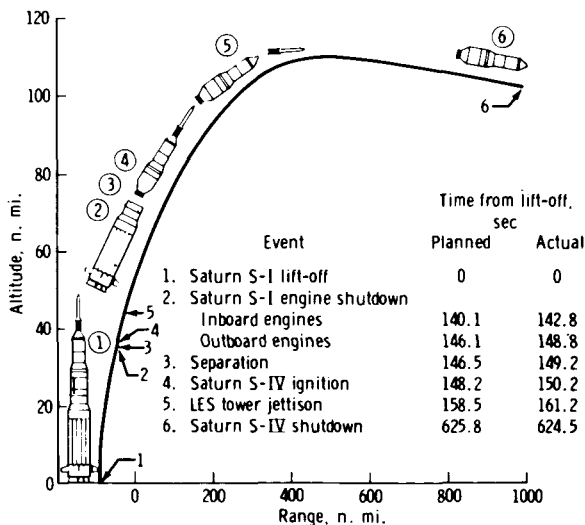

Figure 11. - Major events of Apollo AS-101 mission.

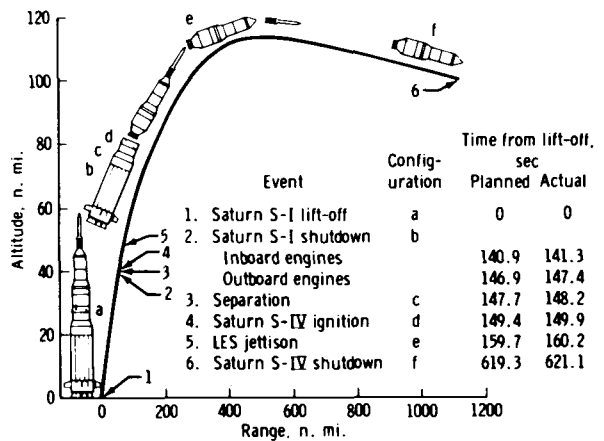

Figure 12. - Major events of Apollo AS-102 mission.

MANNED-FLIGHT PROGRAM

Through the lunar-landing mission, five manned missions involved qualification configurations. There were no aborts that required the use of the LES. During each of these missions, the tower-jettison motors were used, and the performance was nominal.

RESULTS

A summary of Apollo LES qualification flights is given in table III. The capability of the Apollo LES to jettison under nominal launch conditions was verified during the Apollo AS-101 and AS-102 missions. The remaining six Apollo spacecraft abort

TABLE III. - APOLLO LES QUALIFICATION FLIGHTS

Mission designation	Spacecraft	Description	Launch date	Launch site (a)
PA-1	BP-6	First pad abort	November 7, 1963	WSMR
A-001	BP-12	Transonic abort	May 13, 1964	WSMR
AS-101	BP-13	Nominal launch and exit environment	May 28, 1964	KSC
AS-102	BP-15	Nominal launch and exit environment	September 18, 1964	KSC
A-002	BP-23	Maximum-dynamic-pressure abort	December 8, 1964	WSMR
A-003	BP-22	Low-altitude abort (planned high-altitude abort)	May 19, 1965	WSMR
PA-2	BP-23A	Second pad abort	June 29, 1965	WSMR
A-004	SC-002	Power-on tumbling boundary abort	January 20, 1966	WSMR

^aWSMR (White Sands Missile Range, New Mexico); KSC (John F. Kennedy Space Center, Florida).

test flights were conducted to examine the performance of the Apollo spacecraft and the LES under conditions that were not expected during normal manned missions. The abort points for Saturn launch-vehicle flights are shown in figure 13 with the results of the abort-type flight tests.

Flight data for the Apollo A-004 mission are typical of the details that were considered in the flight-test program. The Apollo A-004 mission test point was located within the region of the power-on tumbling boundary. The boundary position was based on the structural-load capability of the Apollo spacecraft and on the altitude and velocity at which the launch escape vehicle could be allowed to tumble during the power-on phase of the abort without undergoing greater-than-design-limit loads. The determination of structural loading was based on the local pressure differential across the CM exterior wall. The pressure differential was caused by the difference between the internal cavity pressure and the combined external effects of the aerodynamic pressure and plume impingement of the launch-escape motor. The Apollo spacecraft design-limit load for this condition was 11.1 psid.

An expanded view of the Apollo A-004 mission test region is shown in figure 14. The test region is bounded by the predicted Little Joe II launch-vehicle maximum- and minimum-performance trajectories and by an allowable pressure dispersion of ± 1.5 psid. With nominal performance of the LEV, a differential pressure of approximately 11.8 psid was predicted during the actual abort of the Apollo A-004 mission. The plume-impingement pressure data that were used in the mission design were approximated from data taken in wind-tunnel tests. The approximation was based on the assumption that the impingement pressures were a direct function of free-stream dynamic pressure and the relationship between plume and free-stream momentum.

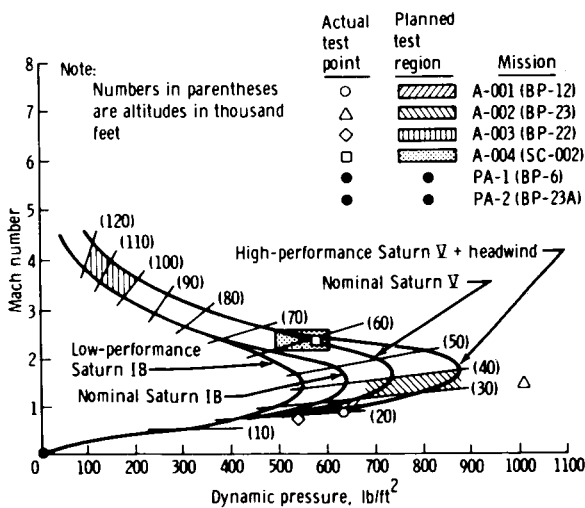

Figure 13. - Mission-abort points in relation to Saturn launch-vehicle flight envelope.

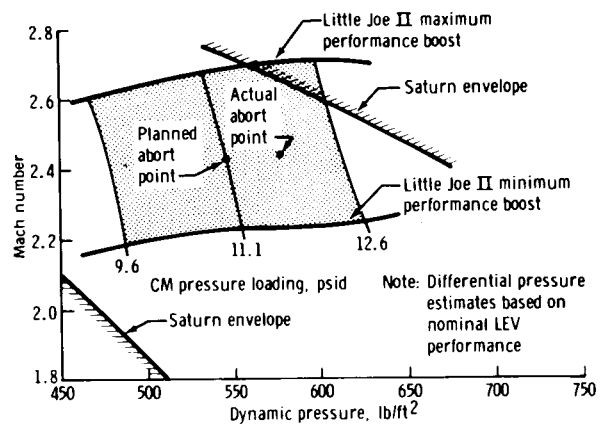

Figure 14. - Test region and abort points for the Apollo A-004 mission.

CONCLUDING REMARKS

In reviewing the failures that were encountered during the development and qualification of this subsystem, it can be seen that adequate definition of both system and test requirements with proper inspection between tests would have eliminated all failures except the tower-jettison motor interstage failure. Even this failure could probably have been avoided with adequate fabrication procedure definition and on-the-spot, real-time inspection.

Manned Spacecraft Center

National Aeronautics and Space Administration

Houston, Texas, October 24, 1972

914-11-00-00-72