



# Seven Mile Project Water Use Plan

*Revised for Acceptance  
by the Comptroller of  
Water Rights*

8 December 2006





# **Seven Mile Project Water Use Plan**

**Revised for Acceptance by the Comptroller of Water Rights**



# Seven Mile Project

## Water Use Plan

Revised for Acceptance by the Comptroller of Water Rights



**R. Kurschner**  
**Director, Generation Resource Management**



## **Preface**

The water use planning process for BC Hydro's Seven Mile Dam and Generating Station was initiated in the late 1980's as part the licensing process associated with the addition of a fourth generating unit. The process was revisited between December 2000 and January 2002 by the reviewing agencies to ensure that operations associated with the entire facility were considered.

The operational changes proposed in this Water Use Plan reflect the consensus recommendations of the *Seven Mile Dam and Generating Station Water Use Plan: Consultative Report* (February 2003).

BC Hydro thanks all those who participated in the process that led to the production of this Water Use Plan, for their effort and dedication. The proposed conditions for the operation of BC Hydro's facilities will not come into effect until implemented under the *Water Act*.





## Table of Contents

<b>1.0</b>	<b>INTRODUCTION .....</b>	<b>1</b>
1.1	<i>Water Use Planning Process .....</i>	<i>1</i>
1.2	<i>Pre Existing Water Licence Obligations and Unit Four Upgrade .....</i>	<i>2</i>
<b>2.0</b>	<b>DESCRIPTION OF WORKS.....</b>	<b>3</b>
2.1	<i>Location .....</i>	<i>3</i>
2.2	<i>Existing Works .....</i>	<i>5</i>
<b>3.0</b>	<b>HYDROLOGY OF THE PEND D'OREILLE BASIN .....</b>	<b>6</b>
3.1	<i>Drainage Basin .....</i>	<i>6</i>
3.2	<i>Runoff Distribution .....</i>	<i>7</i>
<b>4.0</b>	<b>OPERATING CONDITIONS FOR FACILITY .....</b>	<b>7</b>
4.1	<i>Role of Facilities in BC Hydro's System .....</i>	<i>7</i>
4.2	<i>Use of Water for Power Generation.....</i>	<i>8</i>
4.3	<i>Emergencies and Dam Safety .....</i>	<i>10</i>
4.4	<i>Operation of Works for Diversion and Use of Water .....</i>	<i>10</i>
<b>5.0</b>	<b>PROGRAMS FOR ADDITIONAL INFORMATION.....</b>	<b>13</b>
5.1	<i>WUP Monitoring and Works .....</i>	<i>13</i>
5.2	<i>Ancillary Commitments.....</i>	<i>14</i>
<b>6.0</b>	<b>IMPLEMENTATION OF RECOMMENDATIONS.....</b>	<b>14</b>
<b>7.0</b>	<b>EXPECTED WATER MANAGEMENT IMPLICATIONS .....</b>	<b>14</b>
7.1	<i>Other Licensed Use of Water.....</i>	<i>15</i>
7.2	<i>Riparian Rights.....</i>	<i>15</i>
7.3	<i>Fisheries.....</i>	<i>15</i>
7.4	<i>Wildlife Habitat.....</i>	<i>15</i>
7.5	<i>Flood Control .....</i>	<i>16</i>
7.6	<i>Recreation.....</i>	<i>16</i>
7.7	<i>Water Quality.....</i>	<i>16</i>
7.8	<i>Other Potential Use of Water .....</i>	<i>17</i>
7.9	<i>First Nations Considerations.....</i>	<i>17</i>
7.10	<i>Archaeological Considerations .....</i>	<i>18</i>
7.11	<i>Power Generation.....</i>	<i>18</i>

**8.0 RECORDS AND REPORTS.....18**  
8.1 *Compliance Reporting* ..... 18  
8.2 *Non-compliance Reporting* ..... 18  
8.3 *Monitoring Program Reporting* ..... 18

**9.0 PLAN REVIEW .....19**

**10.0 NOTIFICATION PROCEDURES.....19**

**List of Figures**

Figure 1: Location of the Seven Mile Project within the  
Columbia River Basin.....4

Figure 2: Seven Mile Project Arrangement.....6

**List of Appendices**

Appendix 1 Hydrology Memo: Seven Mile

## 1.0 INTRODUCTION

### 1.1 Water Use Planning Process

The Water Use Planning process for the Seven Mile Project differed from the current Water Use Plan process in that many of the recommendations for the project predate the creation of the Water Use Planning provincial guidelines in 1998.

Public consultation around operations at Seven Mile began in the late 1980s with the licensing process for the fourth generating unit expansion. Consultation continued until 1996 when a “draft plan” was written by BC Hydro. Between 1996 and 1998, the draft plan underwent several revisions to address supplementary points raised by those involved in the additional review process: Department of Fisheries and Oceans (DFO), Ministry of Environment, Lands, and Parks (MELP), Ministry of Employment and Investment (MEI), and Canadian Columbia River Inter-Tribal Fisheries Commission (CCRIFC).

By June 1999, parties in the review process noted that the consultative process had primarily focused on the incremental impact of adding a fourth unit. Further discussion was recommended to ensure that operations as a whole were considered. This additional consultative process extended from December 2000 to January 2002. The consultative group relied on the extensive public consultation that had already taken place on the Seven Mile project since 1989.

The operating conditions proposed in this Water Use Plan reflect the December 2002 recommendations of the *Seven Mile Dam and Generating Station Water Use Plan: Consultative Report* (February 2003) based on the original 1996 plan and includes the operation of all four generating units and associated facilities. The basis for the proposed terms and conditions to be authorized under the *Water Act* for the beneficial use of water at the Seven Mile Power Development are set out in this document. Future reference to the Seven Mile project includes all the works including: Seven Mile Dam, Seven Mile Reservoir, and the powerhouse.

The proposed conditions will change current operations and are expected to benefit both fish and recreational interests in the Seven Mile watershed.

A monitoring program and a review period are proposed to study key uncertainties, reinforce operational recommendations, and to enhance future operating decisions. Refer to the *Seven Mile Dam and Generating Station Water Use Plan: Consultative Report* dated (February 2003) for details on the consultative process, interests, objectives, performance measures, key trade-offs, values associated with operating alternatives, expected benefits and the proposed monitoring program.

## 1.2 Pre Existing Water Licence Obligations and Unit Four Upgrade

The original water licence for the Seven Mile Project required “*programs for the protection, or enhancement, of fish and wildlife and for the mitigation of losses of habitat be carried out as directed by the Comptroller of Water Rights*”. Pursuant to these requirements, the Water Comptroller in 1975 ordered BC Hydro to make funds available to the Department of Recreation and Conservation (subsequently MELP) for planning and implementing a fish and wildlife habitat management program.

The primary area of concern related to wildlife habitat impacts was for white-tailed deer and a successful white-tailed deer habitat management program was subsequently implemented. In association with raising the reservoir operating level in 1988, further mitigation and compensation actions were agreed upon. These included construction of a weir on the Salmo River to prevent non-sport fish access, payment to the regional district for purchase of off-site recreational land, and development and operation of a campground and day use area on Seven Mile Reservoir (the Buckley recreational site).

BC Hydro and MELP entered into a memorandum of understanding in 1993 on further programs under the Columbia Basin Fish and Wildlife Compensation Program (CBFWCP). The CBFWCP defined an indexed funding level, recognized lands in the Kootenay Region transferred by BC Hydro to MELP in the past, and acknowledged the monies expended on mitigation or compensation to date by both BC Hydro and MELP. In so far that these requirements are met, the CBFWCP fulfils the existing water licences obligations for the Columbia projects, including the Seven Mile project with respect to “*the protection, or enhancement, of fish and wildlife*”.

Competing water uses, operational impacts of the existing Seven Mile project and potential impacts of operations following commissioning of Unit 4 were identified in the Unit 4 application process. The process was then reviewed by various interested parties which included federal and provincial government agencies, First Nations, regional and local government, regional commissions and economic development groups, business, labour and community organizations, fish and wildlife groups and local residents. The results of the review are documented in the Environmental Assessment Office's “*Seven Mile Generating Station Unit 4 Application Review and Recommendations Report*” issued in March 1996. The Project Approval Certificate was issued on 25 April 1996. An amendment to the Certificate incorporating further agreements reached with the fisheries agencies was issued on 13 March 1997.

During the review process for Unit 4, BC Hydro committed to additional mitigation and compensation measures including:

- enhancement of rainbow and bull trout habitat in selected tributaries of the Pend d'Oreille River;

- construction, contingent on engineering and biological feasibility, of velocity refugia in the Seven Mile Dam tailwater;
- installation of wicket gate seals which, under synchronous-condense operation, will reduce or eliminate leakage of water with high total gas pressure content into the tailrace; and
- monitoring of habitat enhancement.

Details of the above are contained in BC Hydro's *Mitigation and Compensation Plan for the Installation and Operation of Unit 4 at the Seven Mile Generating Station*, dated 22 March 1996. Subsequent to the issue of the Project Approval Certificate, DFO requested an agreement on fish flows to address load shaping impacts on white sturgeon. Agreements between DFO and BC Hydro for implementation of the agreed measures are documented in the *Seven Mile Unit 4 Habitat Compensation Agreement*, made on 22 March 1996, and the *Authorization for Works or Undertakings Affecting Fish Habitat and for Destruction of Fish*, dated 2 December 1996.

Agreements and understandings reached during the review process have been reflected in the preparation of this Water Use Plan.

## **2.0 DESCRIPTION OF WORKS**

### **2.1 Location**

The location of the Seven Mile project within the Columbia River basin is shown in Figure 1.

The Seven Mile Dam and Generating Station are situated on the Pend d'Oreille River in south-eastern British Columbia, approximately 15 km south-east of the City of Trail. The project is 18 km downstream of Seattle City Light's Boundary Project and 9 km upstream from the Waneta Project.



## 2.2 Existing Works

The Seven Mile Dam and Generating Station were built between 1975 and 1980. It consists of a concrete gravity dam with a maximum height of 80 m, four power intake bays, five gated spillway bays and a 4-unit powerhouse. Spillway flows are controlled by vertical lift gates and discharge over ogee crests into a divided chute with two flip buckets. The power plant was designed as a 4-unit facility which would be in approximate hydraulic balance with the ultimate 6-unit development at the Boundary development upstream. The first three units, installed between 1979 and 1981, have a nameplate capacity of 214, 214, and 200 MW, respectively.

The fourth unit, 220 MW nameplate capacity, was installed in 2003 bringing total plant capacity to 848 MW. The original three units at Seven Mile were in approximate hydraulic balance<sup>1</sup> with the original four units of the Boundary Plant upstream. Seattle City Light added two more units at Boundary in 1985, enabling the project to release up to 50 kcfs through generating units. Installation of Unit 4 at Seven Mile re-established the hydraulic balance between Seven Mile and Boundary. Seven Mile is now able to generate up to 52 kcfs prior to spilling. Unit 4 and its auxiliary equipment is similar to the other three units, but incorporates technical improvements that have occurred since the first three units were installed.

The project arrangement is shown in Figure 2.

---

1 Hydraulic balance means the total discharge capacity of the turbines at each plant are similar.

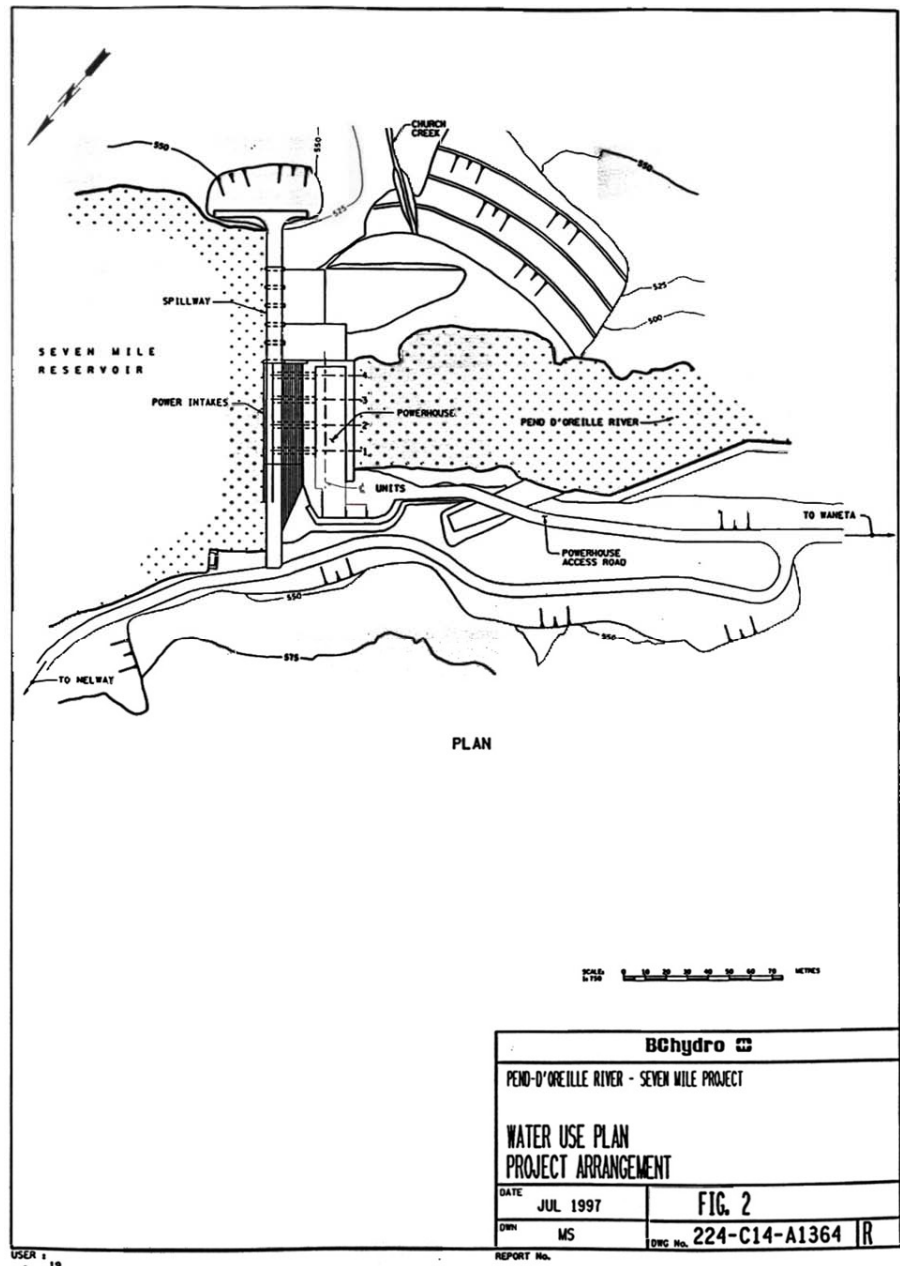

Figure 2: Seven Mile Project Arrangement

### 3.0 HYDROLOGY OF THE PEND D'OREILLE BASIN

#### 3.1 Drainage Basin

The location of the Seven Mile project within the Columbia River basin is shown in Figure 1.



The Pend d'Oreille River enters Canada from the United States and flows for about 25 km in Canada before joining the Columbia River just north of the International Boundary. The Pend d'Oreille River drains ~ 66 800 km<sup>2</sup> of western Montana, northern Idaho, north eastern Washington, and south eastern British Columbia. Less than 5000 km<sup>2</sup> are in Canada. The river basin is generally mountainous and is largely forested.

The main tributaries of the Pend d'Oreille are the Flathead, which rises in the south east corner of British Columbia, and the Blackfoot, Bitterroot, and Clark Fork rivers which flow into Pend Oreille Lake<sup>1</sup>. From the lake the Pend Oreille River flows westerly through Idaho, northerly through Washington, and into British Columbia, where it is joined by the Salmo River. In Canada, the Pend d'Oreille turns westerly, flowing in a 25 km loop before joining the Columbia River, about 15 km downstream from Trail, B.C. just north of the International Boundary. The ten hydroelectric developments on the Pend Oreille and its tributaries upstream from Seven Mile (all of which are located in the U.S.) provide substantial flow regulation for Seven Mile.

### **3.2 Runoff Distribution**

The streamflow characteristics of the Pend d'Oreille River follow the typical pattern of snowmelt dominant basins, with below average flow during the fall and winter, a rapid flow increase in April, a flood peak normally occurring in May or June and a gradually declining flow during the summer. Records show the annual flood peak occurring between 15 May and 15 June approximately 72% of the time, prior to 15 May about 5% of the time, and after 15 June about 23% of the time. Average annual discharge at the Seven Mile project site is approximately 763 m<sup>3</sup>/s.

## **4.0 OPERATING CONDITIONS FOR FACILITY**

### **4.1 Role of Facilities in BC Hydro's System**

Energy generation from the plant with four units in service averages about 3200 gigawatt-hours per year (GW·h/yr.), 6% of BC Hydro's system capability. This is enough electricity to supply about 320 000 homes. Unit 4 added to Seven Mile's annual energy output by more than 300 GW·h/yr, enough for an additional 30 000 homes.

The Seven Mile generating station is part of BC Hydro's integrated generation system. The existing plant capacity up to 848 MW represents about 8% of the system's installed capacity. Power from Seven Mile is transmitted into the provincial grid via two 230 kV lines to Selkirk substation.

---

1 Note the American spelling of Pend d'Oreille is Pend Oreille

Operations at the Seven Mile project are coordinated with operations at Teck-Cominco's Waneta project under the terms of the *Canal Plant Agreement* between BC Hydro, Teck Cominco Metals, FortisBC, Brilliant Power Corporation, Brilliant Expansion Power Corporation, Arrow Lakes Power Corporation and the Waneta Expansion Power Corporation<sup>1</sup>. The *Canal Plant Agreement* (1 July 2005) came into force in April 2006.

The storage capability created by construction of the Duncan Dam under the terms of the Columbia River Treaty and the Libby Dam in the United States provided additional flow regulation for the five existing projects on the Kootenay River, namely Brilliant Power Corporation's Brilliant project<sup>2</sup> and FortisBC's Corra Linn, Upper Bonnington, Lower Bonnington and South Slokan projects. The improvement in streamflow regulation made additional installations on the Kootenay River economic and, as a result, BC Hydro built the 530 MW Kootenay Canal project in 1974–1976. Under the terms of the *Canal Plant Agreement*, the operations of these generating stations, together with Teck-Cominco's Waneta project on the Pend d'Oreille River, are coordinated to maximize power production and the value of energy. When Seven Mile was completed in 1980, its operation was coordinated with the operation of Waneta.

The *Canal Plant Agreement* is a “one operator” coordination agreement. BC Hydro directs operations at all of the projects to maximize the overall generation from all of the plants. In return, the aforementioned parties receive a specified amount of electricity annually, known as their “entitlement”. The entitlement is a calculated figure equal to the amount of power that their generating stations would have produced without the Columbia River Treaty and the Kootenay Canal development. Teck-Cominco, FortisBC, and the Columbia Power Corporation and Columbia Basin Trust joint ventures remain responsible for environmental, social and other requirements associated with the operation of their facilities.

## 4.2 Use of Water for Power Generation

The Seven Mile project has no material impact on the hydrograph of the Pend d'Oreille River. Seven Mile Reservoir is not a storage reservoir in the traditional sense. It only has sufficient capacity for daily pondage and, as such, does not affect weekly or seasonal Pend d'Oreille River flows.

---

<sup>1</sup> Brilliant Power Corporation, Brilliant Expansion Power Corporation, Arrow Lakes Power Corporation and Waneta Expansion Power Corporation are joint ventures of Columbia Power Corporation (CPC) and the Columbia Basin Trust (CBT).

<sup>2</sup> The Brilliant Project was acquired by the Brilliant Power Corporation from Teck-Cominco in 1996. The Brilliant Expansion Power Corporation is currently expanding the existing facilities at the Brilliant Project and is scheduled for commercial operation in the summer of 2007.

The Seven Mile project was designed to be in hydraulic balance with the upstream Boundary plant and the normal reservoir fluctuation was assumed to be small. However, under the provisions of the *Canal Plant Agreement*, it is beneficial for BC Hydro to operate Seven Mile and Waneta in a coordinated manner to maximize overall benefits.

The pattern of water use for power purposes at the Seven Mile project is governed by:

- the amount of flow in the river;
- operating parameters in the water licences;
- the hydraulic capacity of the Seven Mile plant in relation to the capacities of the upstream Boundary plant and the downstream Waneta project and
- daily distribution of discharge from Boundary.

The approximate hydraulic capacities of the three plants are as follows:

<b>Plant</b>	<b>Capacity</b>
Boundary	1416 m <sup>3</sup> /s
Seven Mile (4 units)	1473 m <sup>3</sup> /s
Waneta (4 Units: No expansion)	838 m <sup>3</sup> /s

BC Hydro uses all of the available inflow, within the storage and generation limits of the Seven Mile facilities. When flow in the river is greater than capacity and the forebay is full, spill must occur. This means that in most years there is spill at all three projects during the months of May, June and early July.

Two key factors govern the operation of the Seven Mile/Waneta system:

- (a) typically daily flows from the upstream Boundary plant are released in a 15-hour maximum flow block (6:00 a.m. to 9:00 p.m.) and a 9-hour minimum block (9:00 p.m. to 6:00 a.m.). The maximum flow block can be up to 1420 m<sup>3</sup>/s and the minimum flow block is often zero discharge; and
- (b) it is normally beneficial to minimize spill at Waneta to maximize power generation and to minimize downstream Total Gas Pressure (TGP).

Re-regulation of inflows from Boundary to minimize spill at Waneta causes the Seven Mile reservoir level to fluctuate significantly on a daily basis. To determine the amount of re-regulation necessary, BC Hydro takes into account expected Boundary discharges, potential spills, head losses due to reservoir drawdown, expected Salmo inflows, environmental constraints, and variations in energy values throughout the day. Benefits from re-regulation can be achieved at any time the flow in the river is less than the hydraulic capacity of Boundary (i.e., when Seattle City Light shapes the flow from Boundary as described in (a) above). This situation occurs most of the year, except for the freshet period from May to early July. During the freshet, average river flows are typically greater than Boundary capacity, and are sufficient to run all three plants at full output around the clock. Water levels at all three reservoirs can then be kept at maximum operating level with little daily fluctuations. Excess water is spilled under these conditions.

Short-term peaking operations (i.e., running three or four Seven Mile units for a few hours a day) can also affect reservoir levels, particularly at Waneta. The need for short-term peaking occurs primarily during the winter months (generally mid-November to mid-February but occasionally extending into other months). Because the turbines at Seven Mile can pass more water than those at Waneta, it is occasionally necessary to draw down Waneta reservoir overnight to create some pondage space in the reservoir to absorb the extra discharge from the Seven Mile units the next day without causing a spill at Waneta. Occasionally, short-term peaking operations at Seven Mile may cause additional spill at Waneta.

#### **4.3 Emergencies and Dam Safety**

Emergencies and dam safety requirements shall take precedence over the operational constraints outlined in this Water Use Plan. Emergencies include actual or potential loss of power to customers. Dam safety requirements for operations are outlined in “*Seven Mile Dam: Operation, Maintenance and Surveillance Requirements (OMS) for Dam Safety*,” May 2005 BC Hydro Report No. OMSSEV, which is issued by BC Hydro’s Director of Dam Safety.

Operational instructions for surcharging the reservoirs and undertaking a special drawdown for dam safety purposes are described in the OMS Manual for Dam Safety. Community notification procedures are documented in the Emergency Planning Guide.

#### **4.4 Operation of Works for Diversion and Use of Water**

BC Hydro proposes to operate the Seven Mile hydroelectric facilities in accordance with the conditions outlined below, subject to requirements of the *Canal Plant Agreement*. BC Hydro may not be able to operate within these conditions in the event of an emergency, dam safety requirement, or an extreme hydrological event.

#### 4.4.1 Discharge from the Works

The following definitions are used to guide operations at Seven Mile. The definitions for “reasonable” and “best” efforts were originally defined in the 31 December 1998 Order solely for application at Seven Mile. They are extended here for continuity and were never intended to define operations at other projects where language incorporating “reasonable” and “best” were used less formally.

“daily average inflow” is an estimate based on the previous day’s inflow used to plan operations to meet the license obligations. If, for that day, actual inflows vary from the “daily average inflow” estimate, the licensee must operate to the requirements in 4.4.1 (3).

“reasonable efforts” means the licensee may consider the cost of alternative actions in prioritizing the options for responding to system capacity demands in meeting the obligations in 4.4.1 (1) and (2).

“best efforts” means the licensee must do everything short of cutting firm load or incurring legal liability for operations at Seven Mile Generating Station or elsewhere, in meeting the obligations in 4.4.1 (4).

To minimize the effects of total gas pressure downstream of Waneta on fisheries values, operation constraints recommended for Seven Mile to manage spill at Waneta include:

##### **From 1 September to 31 May**

1. When the “daily average inflow” to Seven Mile Reservoir is less than the total authorized maximum rate(s) of diversion of the Waneta Power Development(s)<sup>1</sup>, the licensee shall make “reasonable efforts” to distribute the discharge from Seven Mile Power Development such that the total instantaneous discharge at the Waneta Dam does not exceed the total authorized maximum diversion rate(s) of the Waneta Power Development(s).
2. When the “daily average inflow” to Seven Mile Reservoir is equal to or greater than the authorized maximum diversion rate(s) of the Waneta Power Development(s), the licensee shall make “reasonable efforts” to distribute discharges from the Seven Mile Power Development in a manner that does not exceed the “daily average inflow”. Discharges will be distributed in such a manner that the Waneta Power Development(s) are loaded at the authorized maximum diversion rate(s) throughout the day to minimize spill downstream of Waneta.

---

<sup>1</sup> Waneta Power Development(s) consists of the Waneta Project, the Waneta Upgrade, and will include the Waneta Expansion Project if licensed.

3. In the event that actual inflows to Seven Mile Power Development cannot be distributed as described in 1 and 2 due to:
  - a. unexpected changes in inflows or inflow shaping from upstream Boundary Generating Station;
  - b. unforecasted high discharges from the Salmo River; or
  - c. a need to respond to system demand resulting in generation discharge at Seven Mile Power Development that exceeds the Waneta Power Development(s) authorized maximum diversion rate(s);

then the licensee shall make “reasonable efforts” to distribute discharges from the Seven Mile Generating Station to minimize the amount of total discharge at Waneta Dam that exceeds the total authorized maximum diversion rate(s) of the Waneta Power Development(s).

#### **From 1 June to 31 August**

4. During this critical white sturgeon spawning/hatching period the licensee shall make “best efforts” to conform with 1, 2, and 3 above.

#### **4.4.2 Ramping Rates**

There are no specific constraints related to ramping rates at the Seven Mile Power Development. Typical ramping characteristics for the power plant and the spillway follow:

(a) **Power Plant Discharges**

The ramping rates for the power plant between zero discharge and maximum discharge are governed by the capability of the power plant to respond to the needs of the electrical system. The power plant can ramp up from zero output to full output in under 10 minutes and back down in a similar time frame. In practice, the minute-to-minute and hour-to-hour variations in electrical demand usually result in a more gradual rate of increase/decrease in output.

In an emergency (for example, the entire load on the plant is instantaneously lost due to a sudden transmission line outage), the plant would automatically shut down for protection of the plant and for safety reasons. In this scenario, the plant could physically go from full discharge to zero discharge in approximately 10 seconds.

(b) **Spillway Discharges**

The powered operating speed of the spillway gates is 1.8 feet/minute. The time required to open the gates from the fully closed position to fully open is approximately 30 minutes.

In practice, the spillway is normally operated only when the required discharge at the Seven Mile project is greater than the turbine capacity. This generally occurs during the freshet period and spillway discharge ramping rates then closely approximate the natural variations of the river hydrograph.

#### **4.4.3 Flushing Flows**

Seven Mile Reservoir has limited storage capacity (sufficient only for daily pondage) and must pass whatever flows are received from upstream on an average daily basis. As such, Seven Mile does not have the capability for independently providing flushing flows.

#### **4.4.4 Operation Of Storage Works**

The reservoir operating level may fluctuate throughout the year as water is alternately taken into storage and released from storage in response to continually changing rates of reservoir inflow and outflow. The cumulative volume of water taken into storage is unlimited with respect to time.

During normal operations the reservoir may fluctuate between the normal maximum operating level of 527.3 m and the minimum operating level of 514.8 m.

During unusual or emergency conditions the reservoir may reach the surcharge level of 527.9 m or the minimum water level of 483.11 m.

To enhance recreational opportunities and minimize effects on fisheries values, during the summer recreational period (1 June – 31 August) BC Hydro will make reasonable efforts to limit the daily fluctuation of the reservoir to less than 4 m and the hourly fluctuation to less than 0.6 m. It is expected that this can be achieved for at least 82 days of the 92 day period (~90% of the time).

To minimize effects on fisheries values, during the remainder of the year (1 September – 31 May) BC Hydro will make reasonable efforts to limit the daily fluctuations of the reservoir to less than 6 m and the hourly fluctuation to less than 1.2 m. It is expected that this can be achieved for at least 248 days of the 273 day period (~90% of the time).

## **5.0 PROGRAMS FOR ADDITIONAL INFORMATION**

### **5.1 WUP Monitoring and Works**

In addition to the operational requirements, the Consultative Report required the implementation of a monitoring program. Upon direction from the Comptroller of Water Rights, BC Hydro will undertake a monitoring program that will:

- Determine the significance of fish stranding below Seven Mile Dam during flow reduction events. If such works will significantly decrease stranding impacts, re-contouring the stream bars may be required in lieu of adopting ramping rates and minimum flows. Areas to be considered for such works are detailed in “*Seven Mile Tailrace Fish Stranding Assessment*” (2001 B Westcott).
- Establish a better understanding of bull trout life history in the Salmo River system and to identify limiting factors affecting population recovery in relation to operation of Seven Mile. A complete description of this study proposal, including tagging and tracking, can be found in the *Water Use Plan Consultative Report*.

Estimated annual costs and timelines for these studies and associated tasks are summarized in the *Seven Mile Water Use Plan Consultative Report* (February 2003).

## 5.2 Ancillary Commitments

BC Hydro has also committed to collect and report on certain information as detailed in the *Mitigation and Compensation Plan for the Installation and Operation of Unit 4 at the Seven Mile Generating Station*, dated 22 March 1996, and associated agreements including the *Seven Mile Unit 4 Habitat Compensation Agreement* and the *Authorization for Works or Undertakings Affecting Fish Habitat and for Destruction of Fish*, dated 2 December 1996. The data to be collected and reported are detailed in these referenced documents and subsequent amendments thereto.

BC Hydro also funds and participates in the collection of environmental information through studies carried out under the Columbia Basin Fish and Wildlife Compensation Program.

## 6.0 IMPLEMENTATION OF RECOMMENDATIONS

The proposed operating conditions in this Water Use Plan will be implemented in full after BC Hydro receives direction from the Comptroller of Water Rights. This direction will supersede the obligations under the 31 December 1998 Order.

The monitoring plans, proposed in this Water Use Plan, will be implemented after BC Hydro receives direction from the Comptroller of Water Rights.

## 7.0 EXPECTED WATER MANAGEMENT IMPLICATIONS

Implications for non-power water use interests are discussed below. Expected outcomes were based on the best available information at the time of the consultation.



After BC Hydro has been directed to implement the operational changes, BC Hydro will be responsible for meeting the operational parameters ordered in its licensing but not for achieving the expected outcomes.

### **7.1 Other Licensed Use of Water**

Teck-Cominco downstream at Waneta is the other operating licensee “for the purpose of power” on the Pend d'Oreille River in Canada. BC Hydro directs operations at Waneta under the terms of the *Canal Plant Agreement* to maximize overall benefits from Waneta and Seven Mile, subject to Water Licence and Order obligations. In addition to Teck-Cominco, the Waneta Expansion Power Corporation, a joint venture of Columbia Power Corporation and Columbia Basin Trust, applied for a water licence in November 2003 pursuant to a future project (435 MW) at Waneta. Unrecorded waters on the Pend d'Oreille River in the vicinity of Waneta are currently reserved for CPC and the CBT.

### **7.2 Riparian Rights**

Most of the property adjacent to Seven Mile Reservoir is owned by BC Hydro. Some property at the upstream end of the reservoir is privately owned. Riparian rights of those owners are not expected to be affected by this Water Use Plan.

### **7.3 Fisheries**

Downstream of Waneta reservoir, there is white sturgeon spawning and rearing habitat at the Pend d'Oreille/Columbia confluence in an area known as the Waneta Eddy. Concern has been expressed that this habitat may be adversely affected by load-shaping operations at Seven Mile and Waneta at certain times of the year, particularly during the critical white sturgeon spawning/hatching period of June, July and August. The proposed conditions are expected to benefit the fish, particularly sturgeon, downstream of Waneta by minimizing the potential for TGP generation.

Under the proposed operations, daily flow fluctuations limit habitat availability which may decrease fish productivity. Fish may be stranded immediately downstream of Seven Mile during rapid changes in flow from the facility. During spring time, spawning areas may be flooded due to the fluctuations in reservoir levels.

### **7.4 Wildlife Habitat**

Bird surveys indicate relatively low presence of bird species in the reservoir area. Even with stable water levels, the reservoir would not be expected to offer a diversity of habitats for waterfowl. The relatively uncomplex shoreline offers little in the way of nesting or brood-water habitat. The east-west orientation of the Pend d'Oreille River valley limits its use for north-south waterfowl and shorebird migrations. It is unlikely that operation of the reservoir has significant impacts on bird populations.

Fluctuating water levels can occasionally cause problems for wildlife in winter if a drop in water levels occurs after an ice cover has formed. It becomes a hazard for deer attempting to cross the reservoir. The resultant sloping ice surface at the shore can compromise wildlife migrating across the ice. Large daily fluctuations in reservoir levels due to load factoring at Boundary Dam upstream causes a loss of littoral zone habitat.

## **7.5 Flood Control**

Seven Mile reservoir has no storage capacity other than daily pondage, and therefore has no effect on floods on the Pend d'Oreille River.

## **7.6 Recreation**

Water-based recreational activities in the Seven Mile and Waneta reservoirs consist of boating, water skiing, fishing and swimming. Recreational development in the valley is limited to two viewpoints at Seven Mile Dam and a campground and day use area on Seven Mile Reservoir (Buckley Picnic Area and Campground), all of which are operated by BC Hydro. Several informal recreation sites are situated along the north shore of Waneta and Seven Mile reservoirs. There are no commercial navigation operations on the Pend d'Oreille River.

Recreational activity in the area is light to moderate. The peak period for recreational use occurs between May and September. Winter recreational use of the reservoirs is infrequent.

Large daily fluctuations in reservoir levels affect boat launching, beach and swimming activities. The proposed conditions for management of within day reservoir fluctuations are expected to improve recreation access and experience.

## **7.7 Water Quality**

### **Water Chemistry**

The Pend d'Oreille River and reservoirs in Canada are oligotrophic (have insufficient nutrients for abundant plant or animal life) and are characterized as alkaline (pH range from 7.6 to 8.7). Metal concentrations of lead, copper and zinc are within drinking water standards. Water chemistry is not expected to be affected by this Water Use Plan.

### **Temperature**

Water temperatures in the Canadian portion of the Pend d'Oreille River are primarily determined by the temperature of the water released from Boundary Dam. Water temperatures in Seven Mile Reservoir are fairly uniform from the surface to the bottom due to the short retention time (about one day) of the reservoir. Water temperature is not expected to be affected by this Water Use Plan.

## **Dissolved Gases**

The Pend d'Oreille River in Canada has been high in total gas pressure (TGP) since before construction of the Seven Mile Dam. Pre-construction TGP readings of up to 140% of air saturation have been recorded, with frequent exceedences of 110%. Recent data show TGP levels in the Seven Mile tailwater from 98% to 138%.

In general, high TGP production from dam operations has been attributed to dam spillway action whereby spilled water and air falling into the tailwater are carried to depth, where hydrostatic pressure forces air into solution. However, the Seven Mile spillway was designed with a terminal “jump” which distributes the discharge over the surface of the tailwater reducing the plunge depth. Sampling carried out during the 1996 freshet at discharges up to about 2300 m<sup>3</sup>/s has confirmed that there is no additive TGP associated with spill at Seven Mile and, in fact, may reduce TGP. Turbine discharge at hydroelectric power plants has been shown to result in little or no increased TGP.

Operation of the Seven Mile units in “synchronous-condense” mode, in which the turbine wicket gates are closed but the runner continues to spin over a bubble of compressed air, may cause localized increases in TGP in the immediate vicinity of the draft tubes from the discharge of very small quantities (leakage only) of high TGP water.

### **7.8 Other Potential Use of Water**

Seven Mile reservoir is not used for industrial or domestic water supply except as a source of potable water at the Seven Mile facility. This Water Use Plan is not expected to have implications for other uses of water.

### **7.9 First Nations Considerations**

The Columbia Basin falls within the traditional territories of the Shuswap Nation Tribal Council, the Ktunaxa-Kinbasket Tribal Council and the Okanagan First Nations. These groups have formed the Canadian Columbia River Inter-Tribal Fisheries Commission (CCRIFC). CCRIFC member First Nations may include the following bands: Columbia Lake, Lower Kootenay, St. Mary's, Tobacco Plains, Shuswap, Lower Similkameen, Okanagan, Osoyoos, Penticton, Upper Nicola, Upper Similkameen and Westbank.

CCRIFC's mandate is to deal with fisheries and related issues on the Columbia River system of interest to First Nations. Since the summer of 1995, CCRIFC has participated in the development of the mitigation and compensation plan, including the fisheries habitat compensation program and monitoring requirements for the Seven Mile Unit 4 Project with DFO and MELP, to ensure that the interests of its member First Nations with respect to fisheries and other interests were incorporated.

In March 1996, CCRIFC updated its member First Nations on the conclusions of the Unit 4 environmental review. CCRIFC advised that the interests of member First Nations with respect to fisheries had been adequately addressed by the DFO Authorization. Most recently, CCRIFC has been an active participant in the development of the Seven Mile Water Use Plan. In this role, CCRIFC has kept its member bands informed and has raised issues of concern to First Nations. In addition, the Sinixt Nation has been kept informed on the project by CCRIFC, although it is not a member of CCRIFC.

The proposed conditions are expected to benefit fish in river downstream of Seven Mile and Waneta.

### **7.10 Archaeological Considerations**

The proposed conditions in the Water Use Plan are not expected to affect archaeological sites or traditional use of the area. No archaeological sites were identified.

### **7.11 Power Generation**

The proposed conditions in the Water Use Plan (reservoir constraints and load shaping) are not expected to decrease the value of energy associated with power generation at the Seven Mile Power Development relative to regulation under the 31 December 1998 Order.

## **8.0 RECORDS AND REPORTS**

### **8.1 Compliance Reporting**

BC Hydro will submit data as required by the Comptroller of Water Rights to demonstrate compliance with the conditions conveyed in the Water Licences and associated orders under the *Water Act*. The submission will include records of:

- Actual inflow to Seven Mile forebay;
- Seven Mile forebay elevations;
- Seven Mile turbine discharge; and
- Total discharge from Seven Mile Power Development.

### **8.2 Non-compliance Reporting**

Non-compliance with licence conditions, or anticipation thereof, will be reported to the Comptroller of Water Rights in a timely manner.

### **8.3 Monitoring Program Reporting**

Reporting procedures will be determined as part of the detailed terms of reference for each study or undertaking.

## 9.0 PLAN REVIEW

A review of this plan is recommended within ten years of its implementation. The group recommended that this WUP be reviewed earlier if one of the following events:

1. Imminent, significant changes to upstream facilities or operations. It is anticipated that this includes, but is not limited to, physical changes to Boundary Dam and FERC relicensing of that facility;
2. Imminent, significant changes to downstream facilities. It is anticipated that this includes, but is not limited to, an expansion of the Waneta facilities; or
3. Emergent water use issues. It is expected that this may include, but not be limited to, the establishment of a strong link between bull trout entrainment and dam operations at the end of the five year monitoring program or new information making a strong link between white sturgeon and dam operations.

## 10.0 NOTIFICATION PROCEDURES

Notification procedures for floods and other emergency events are outlined in the “Seven Mile Dams Emergency Planning Guide” and the “Power Supply Emergency Plan: West Kootenay Generation (Duncan, Hugh Keenleyside, Kootenay and Seven Mile dams)”. Both these documents are filed with the Office of the Comptroller of Water Rights.



## **Appendix 1**





## Inter-office memo

TO: Darren Sherbot Date: 21 November 2006  
FROM: Shaileen Ebrahim File: REGWUP SEV  
SUBJECT: Seven Mile Project – Hydrology of Seven Mile Watershed

---

### 1.0 INTRODUCTION

Seven Mile Dam is located in south-eastern British Columbia near the town of Trail. The project is situated about 14 km downstream of the Canada-US border on the Pend d'Oreille River. The confluence of the Columbia and Pend d'Oreille Rivers is located about 10 km downstream of the project.

The Seven Mile Project was constructed from 1975 – 1980 and consists of the following major features:

- concrete gravity dam
- power intakes
- 5 gated spillway section
- generating station ( 4 units, 848 MW, 1473 cms max. discharge).

This report highlights the project characteristics and hydrology of the Seven Mile Project. Typical inflow hydrographs and summaries are provided.

### 2.0 PHYSIOGRAPHY<sup>1</sup>

The Pend d'Oreille River has its headwaters on the western slopes of the Continental Divide in the Rocky Mountains of Montana and British Columbia. The river flows from Pend d'Oreille Lake in Idaho in a westerly direction into Washington, and then northerly into British Columbia. In Canada, the river turns westerly flowing in a 24 km loop through Seven Mile Dam reservoir and the Waneta Dam reservoir before joining the Columbia River.

The main tributaries of the Pend d'Oreille are the Flathead, which rises in the south-east corner of British Columbia and the Blackfoot, Bitterroot and Clark Fork rivers which flow into Pend d'Oreille Lake in Idaho. Within the Seven Mile Project reservoir, the Pend d'Oreille River is joined by the tributary Salmo River.

The total drainage area upstream of the Seven Mile Dam site is about 66 800 km<sup>2</sup>. The local watershed area between Boundary Dam and Seven Mile dam is 1463 km<sup>2</sup> of which 1200 km<sup>2</sup> is the watershed area for the Salmo River.

---

<sup>1</sup> BC Hydro. June 1985. "Seven Mile Dam: Dam Breach Inundation Study", BC Hydro Hydroelectric Generation Projects Division, Report No. H1826.

Various other hydroelectric projects are developed on the US portion of the river with Boundary Dam immediately upstream of the Seven Mile Project. The Seven Mile Reservoir extends upstream across the Canada-US border to the tail water of Boundary Generating Station. Figure 1 shows a schematic of the various projects that regulate the Pend d'Oreille River System.

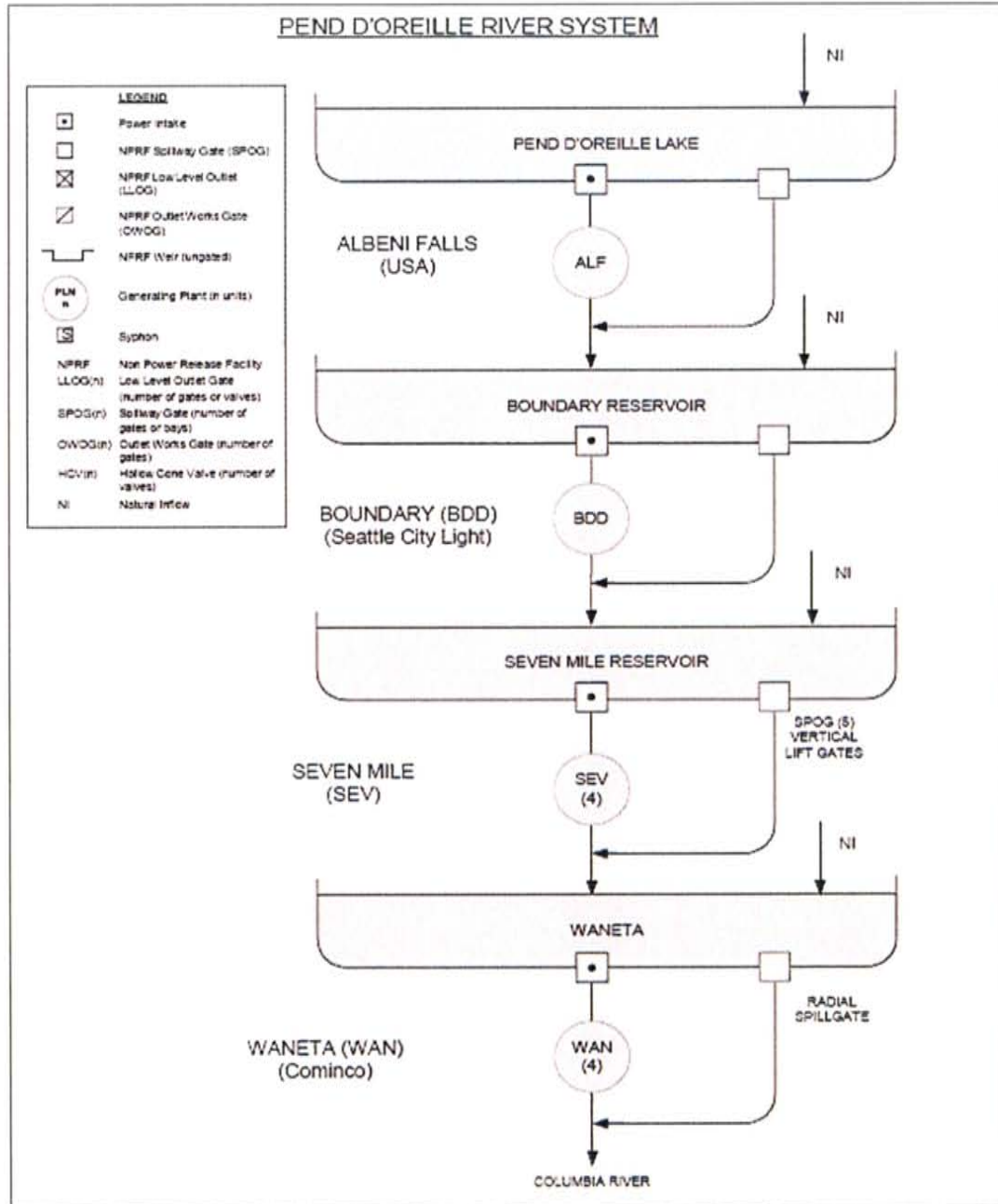
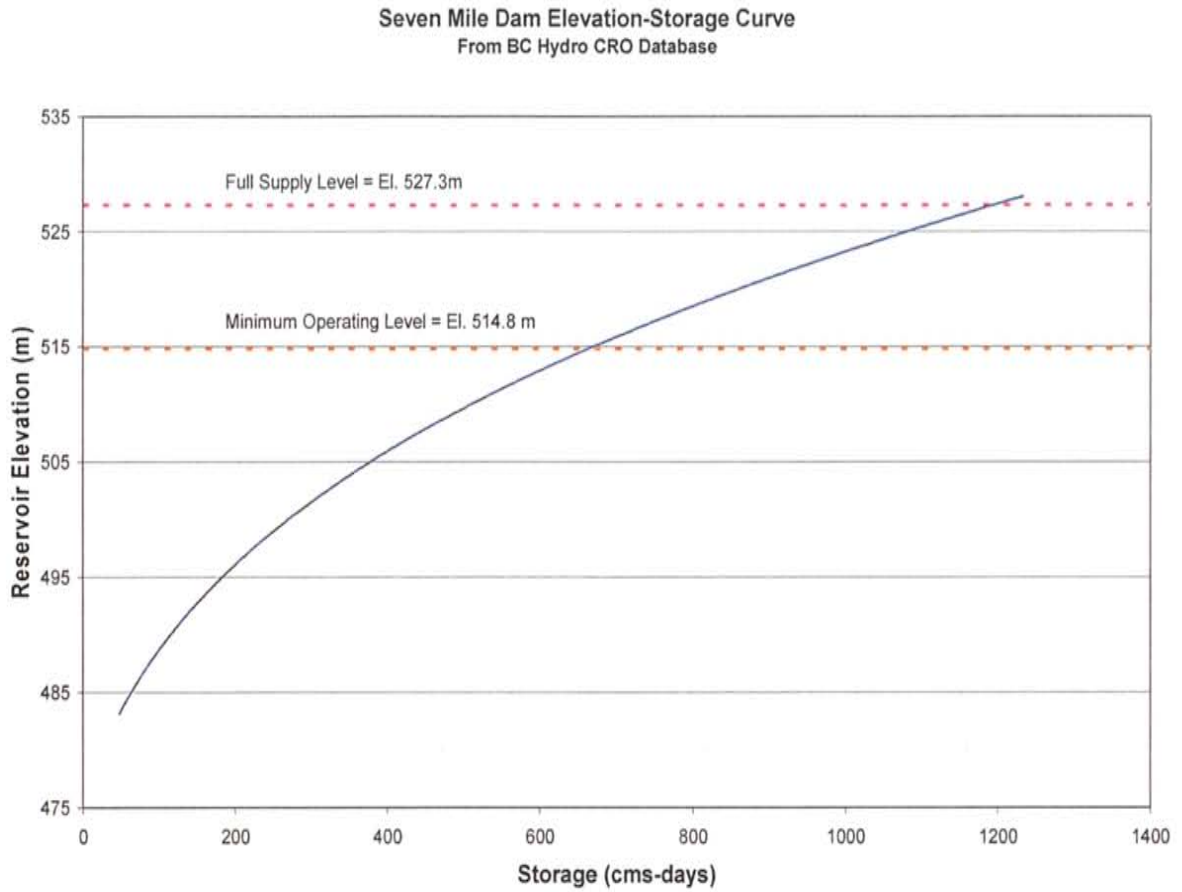

Figure 1: Pend d'Oreille River System

Figure 2 below shows the elevation-storage relationship for Seven Mile Dam reservoir within its normal reservoir operating ranges. Between its full supply level (El. 527.3 m) and minimum operating level (El. 514.8 m) Seven Mile reservoir has a storage capacity of approximately 532 cms-days (45.96 Mm<sup>3</sup>).



*Figure 2: Stage-storage relationship for Seven Mile Reservoir*

Figure 3 below shows the discharge rating curve for the Seven Mile project spillway.

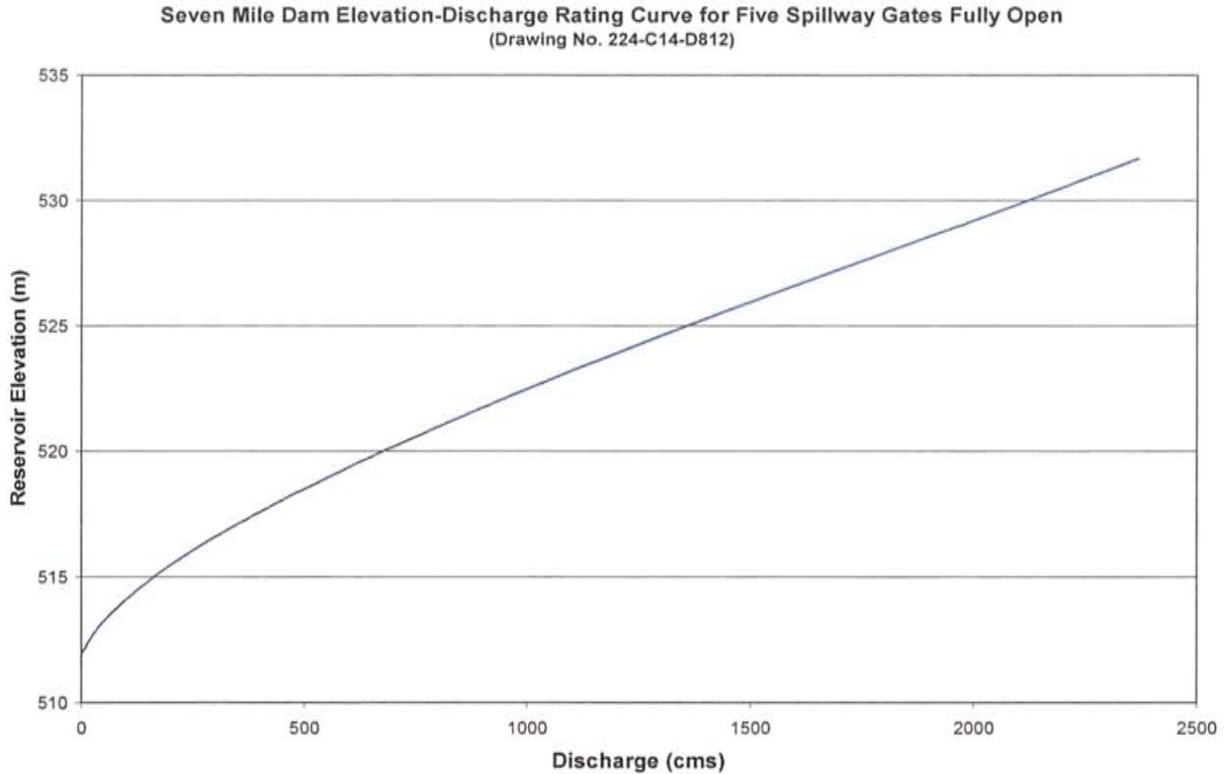

*Figure 3: Rating curve for Seven Mile Dam with five spillway gates fully open*

### 3.0 CLIMATOLOGY<sup>2</sup>

There are several long-term climate stations in the vicinity of the Seven Mile Dam basin. The AES station at Castlegar A is considered to be a good representation of temperature and precipitation in the basin. Average annual precipitation is 736 mm (1966-2003).

Figure 4 shows maximum, average and minimum monthly precipitation at the Castlegar A Climate Station to highlight the year-to-year variations in precipitation conditions, while Figure 5 shows the maximum, mean, and minimum daily temperatures at the Castlegar A Climate Station.

<sup>2</sup> BC Hydro. June 1985. "Seven Mile Dam: Dam Breach Inundation Study", BC Hydro Hydroelectric Generation Projects Division, Report No. H1826.

Mean, Maximum and Minimum Monthly Precipitation at the  
Castlegar A Climate Station (1966 – 2005)

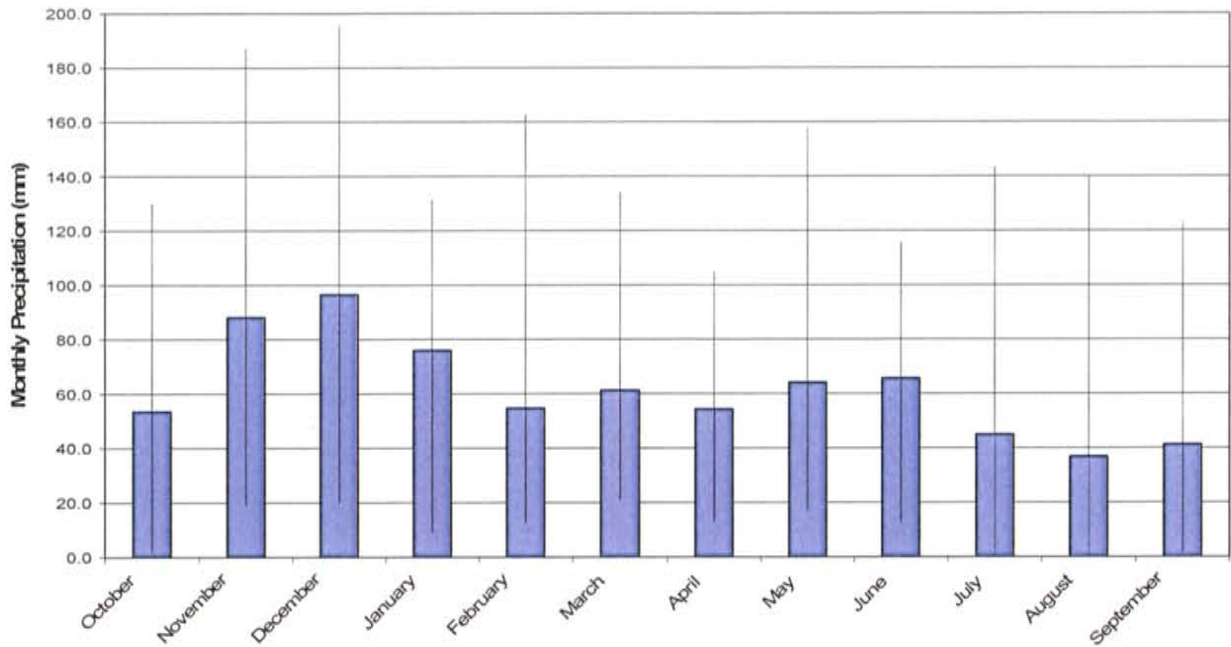

Figure 4: Maximum and minimum monthly precipitation at the Castlegar Station A

Mean, Maximum and Minimum Daily Temperature at the  
Castlegar A Climate Station (1966 – 2005)

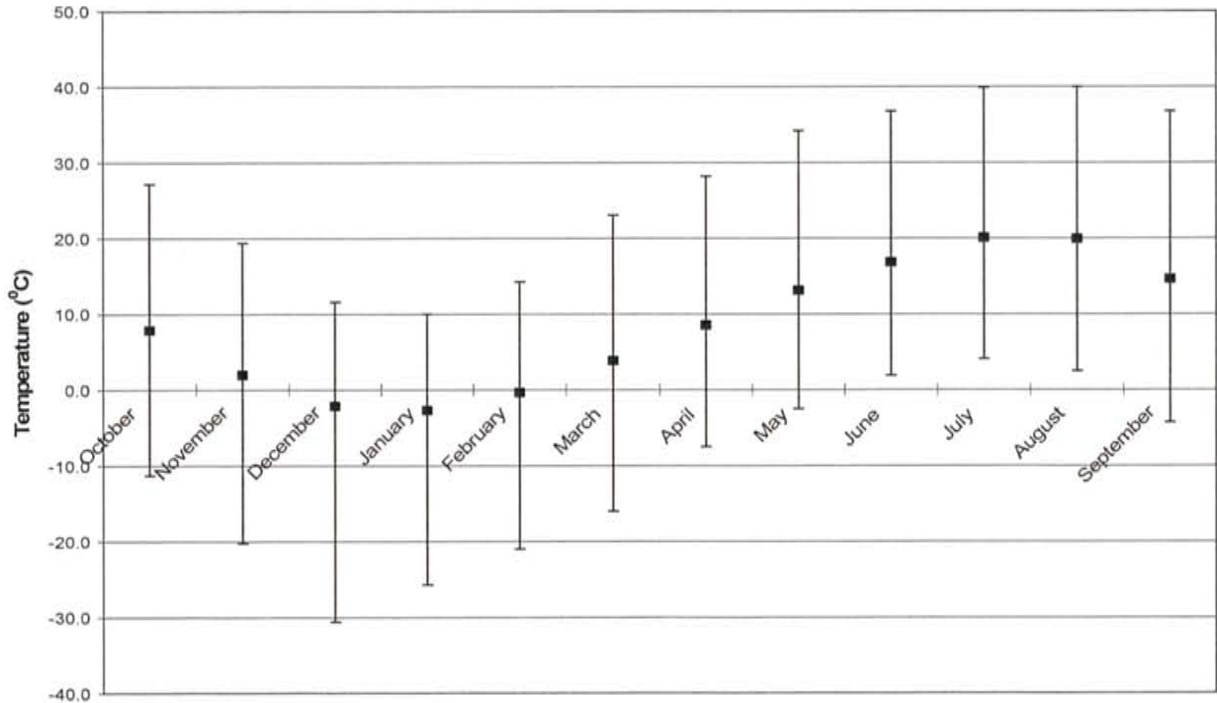
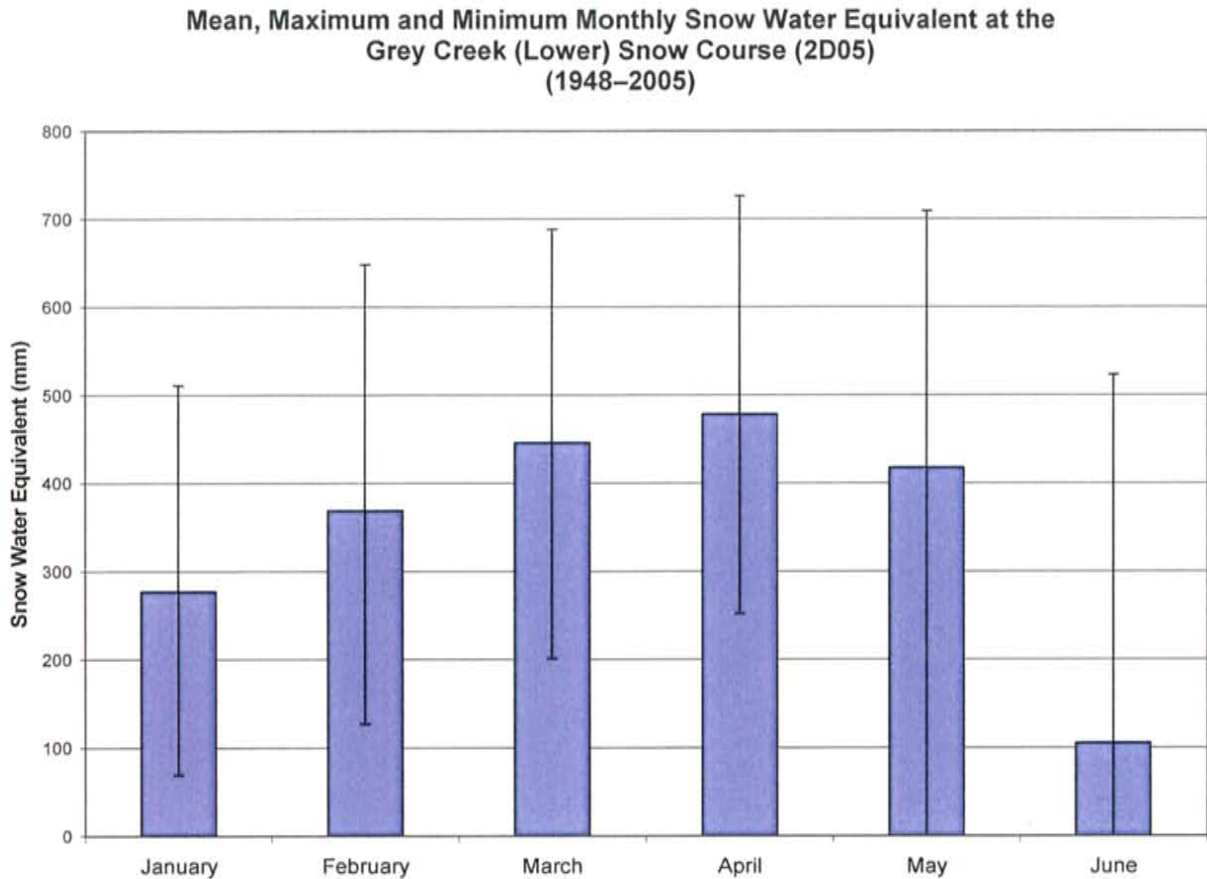

Figure 5: Maximum, mean and minimum daily temperature at Castlegar A Climate Station

Figure 6 shows the normal monthly snow water equivalent at Grey Creek (Lower) snow course (2D05), located in the West Kootenay basin at El. 1550 m.



*Figure 6: Maximum, mean and minimum monthly snow water equivalent at Grey Creek (Lower) snow course (2D05)*

#### 4.0 RESERVOIR INFLOW CHARACTERISTICS

The local inflow to Seven Mile Dam is dominated by the regulated outflows from Boundary Dam. Non-regulated, natural inflows from the local watershed between Boundary and Seven Mile Dams consist mainly of the tributary flows from the Salmo River. The natural inflow between the two projects typically contributes approximately 1% -5 % of the total annual project inflow. Figures 7 shows “spaghetti plots” of historical natural inflows to the Seven Mile project, while Figure 8 shows the historic regulated outflows from Boundary Dam. The 10th, 50th and 90th percentile inflows are shown in bold.

### Historic Natural Daily Inflow Hydrographs to Seven Mile Dam (1980-2005)

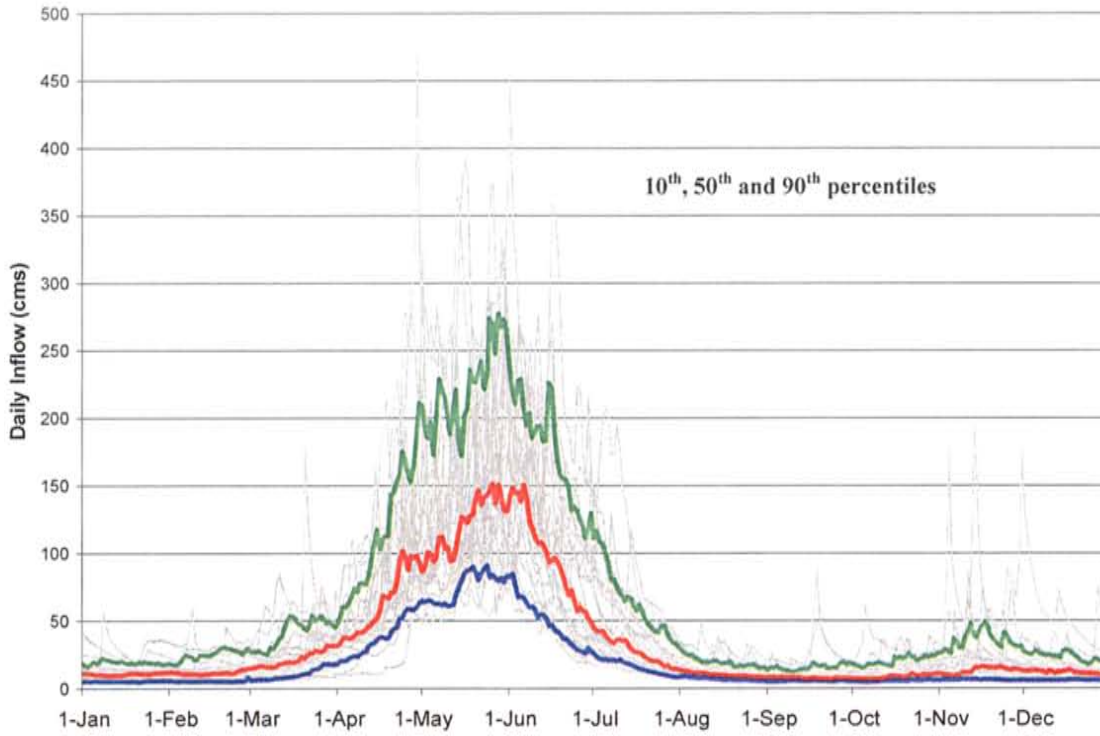

Figure 7: Historical daily natural inflows to Seven Mile Dam

### Historic Regulated Daily Outflow Hydrographs from Boundary Dam (1985-2005)

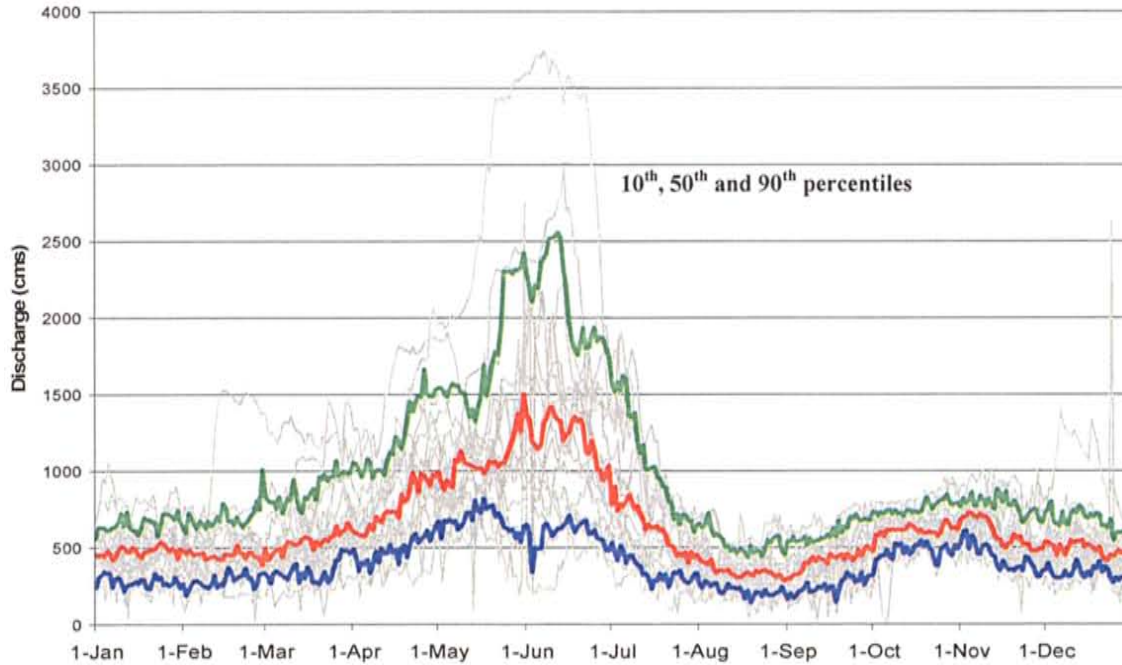
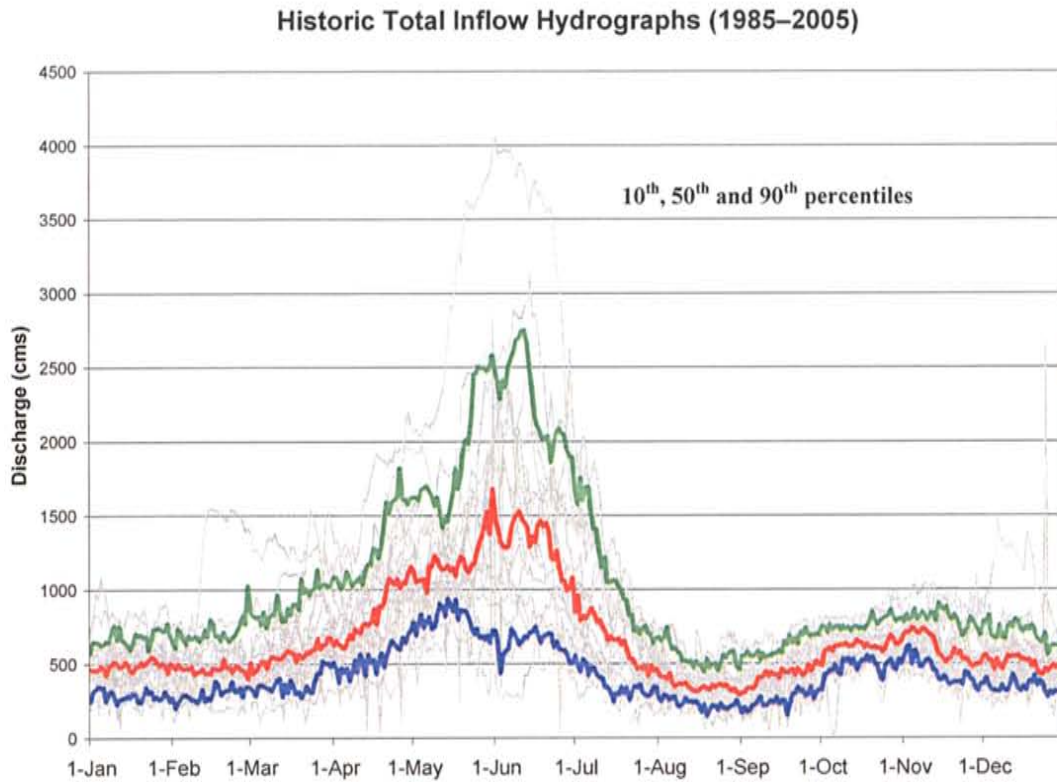

Figure 8: Historical regulated upstream discharge (Boundary Dam outflow)

Figure 9 shows the historic total inflow to the Seven Mile project (natural inflow plus Boundary outflows). The mean annual inflow equates to 560 cms.

The maximum project turbine flow is 1473 cms. The project can regulate inflows during most of the year but given the relatively small amount of reservoir storage, spilling may occur during the months of May, June and July.

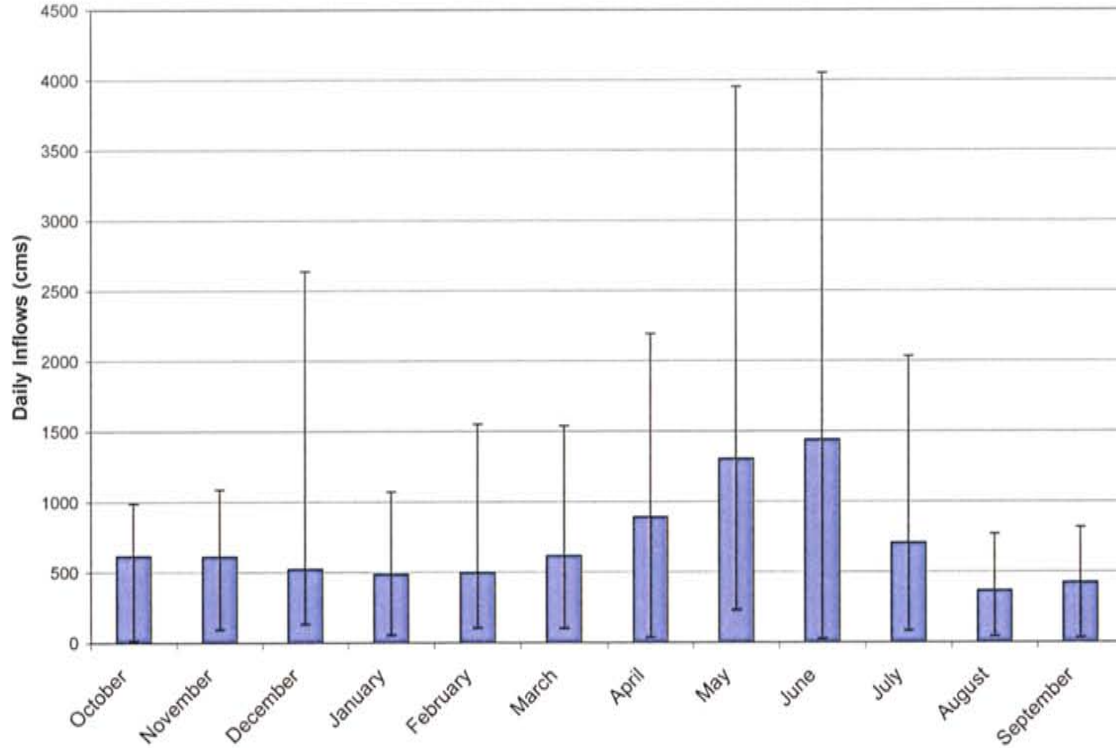

*Figure 9: Historical total inflow (regulated + natural inflow)*

Figure 10 and Table 1 below summarize the total daily inflows by month. Average monthly and maximum and minimum daily inflows are shown to highlight the variability of inflows to the project.



**Variability in Seven Mile Dam Daily Inflows (Regulated + Natural Inflows)  
(1985–2005)**



*Figure 10: Variability in Seven Mile Dam Project's daily inflows (regulated + natural inflow)*

**Summary of Inflows (Regulated + Natural Inflows)**

	Mean	Maximum	Minimum
October	615	988	14
November	611	1087	94
December	522	2639	132
January	484	1070	53
February	497	1551	104
March	616	1541	100
April	892	2195	38
May	1303	3951	229
June	1438	4051	27
July	707	2034	83
August	367	769	43
September	425	817	34

*Table 1: Seven Mile Dam Project's daily inflows (1985-2005) (regulated + natural inflow)*

A “flow duration curve” indicates the percent of time that a flow is less than a given discharge. Figure 11 shows a flow duration curve of daily natural inflows for the years 1980–2005. The figure again illustrates the large range and variability of inflows.

**Daily Flow Duration to Seven Mile Reservoir (Regulated + Natural Inflows)  
(1985–2005)**

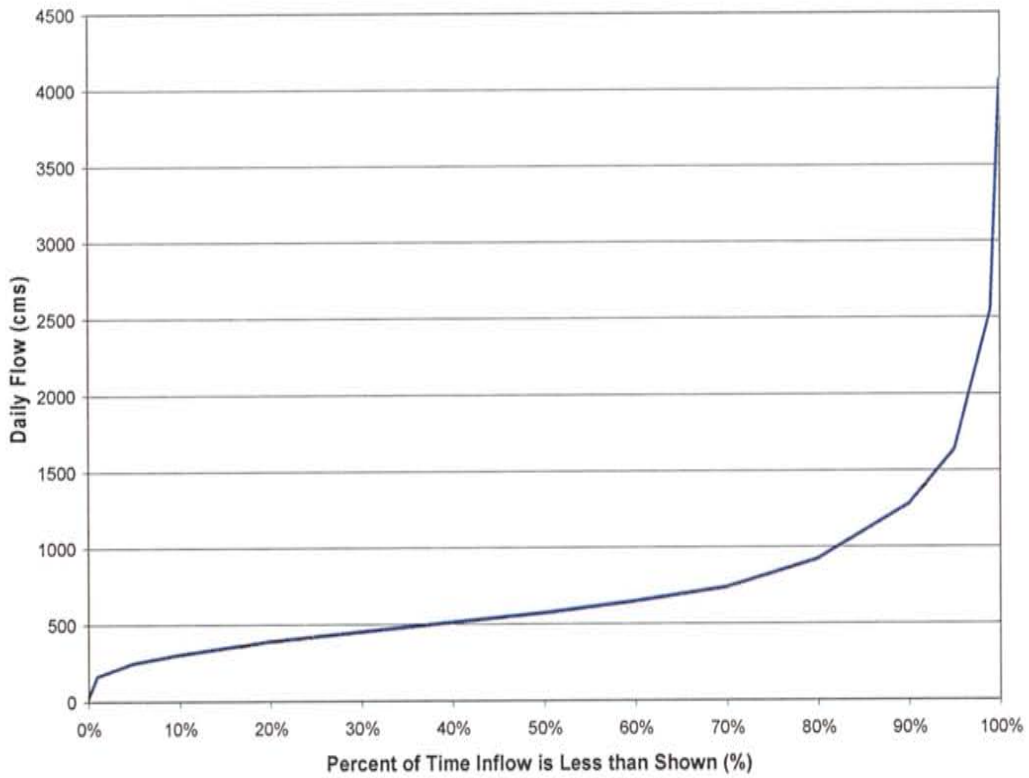

**Figure 11: Duration curves of natural daily inflows to the Seven Mile Dam Project (regulated + natural inflows)**

Figure 12 below shows a duration curve for annual total inflows.

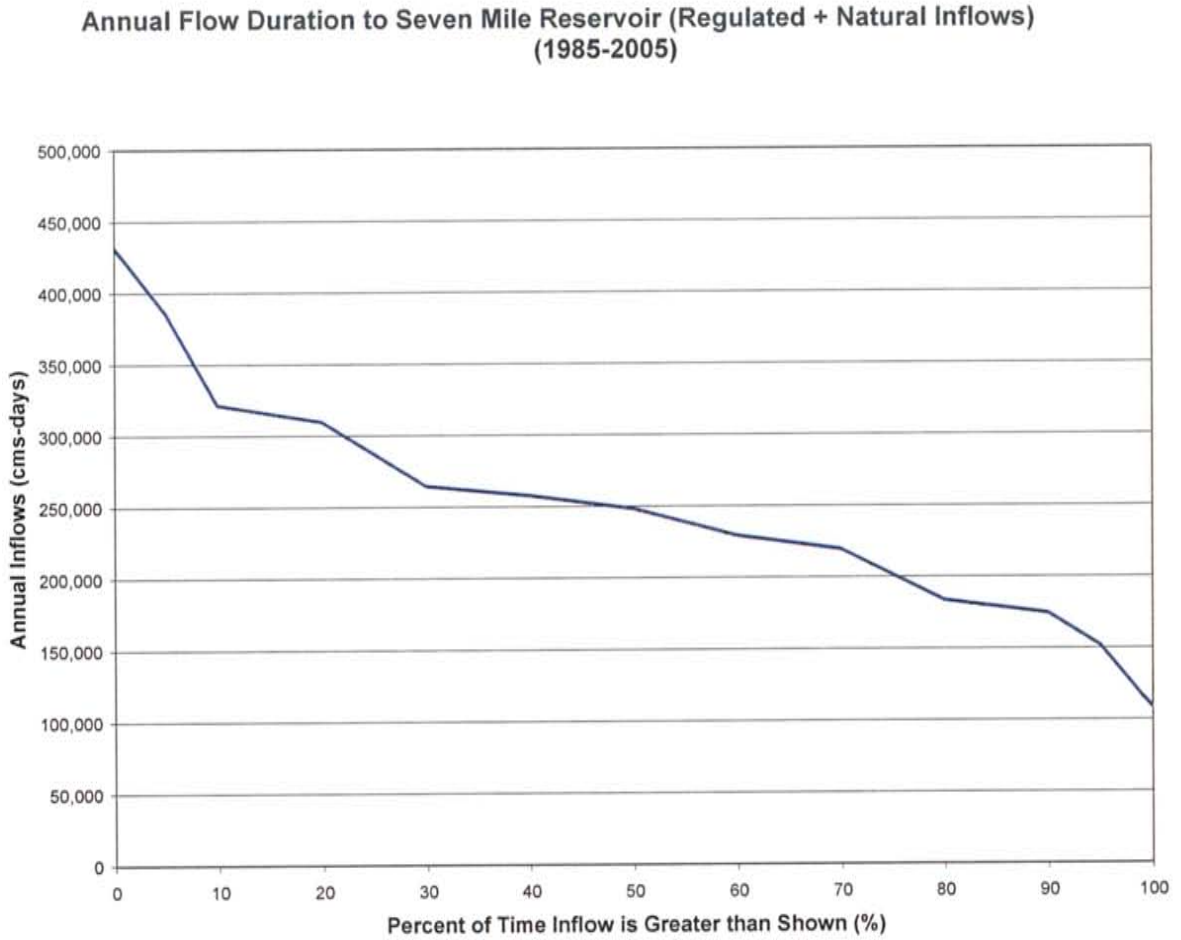

*Figure 12: Duration curve of annual inflows to the Seven Mile Dam Project (regulated + natural inflows)*

Lastly, Figure 13 below displays the comparison of project annual inflows to the reservoir storage capacity

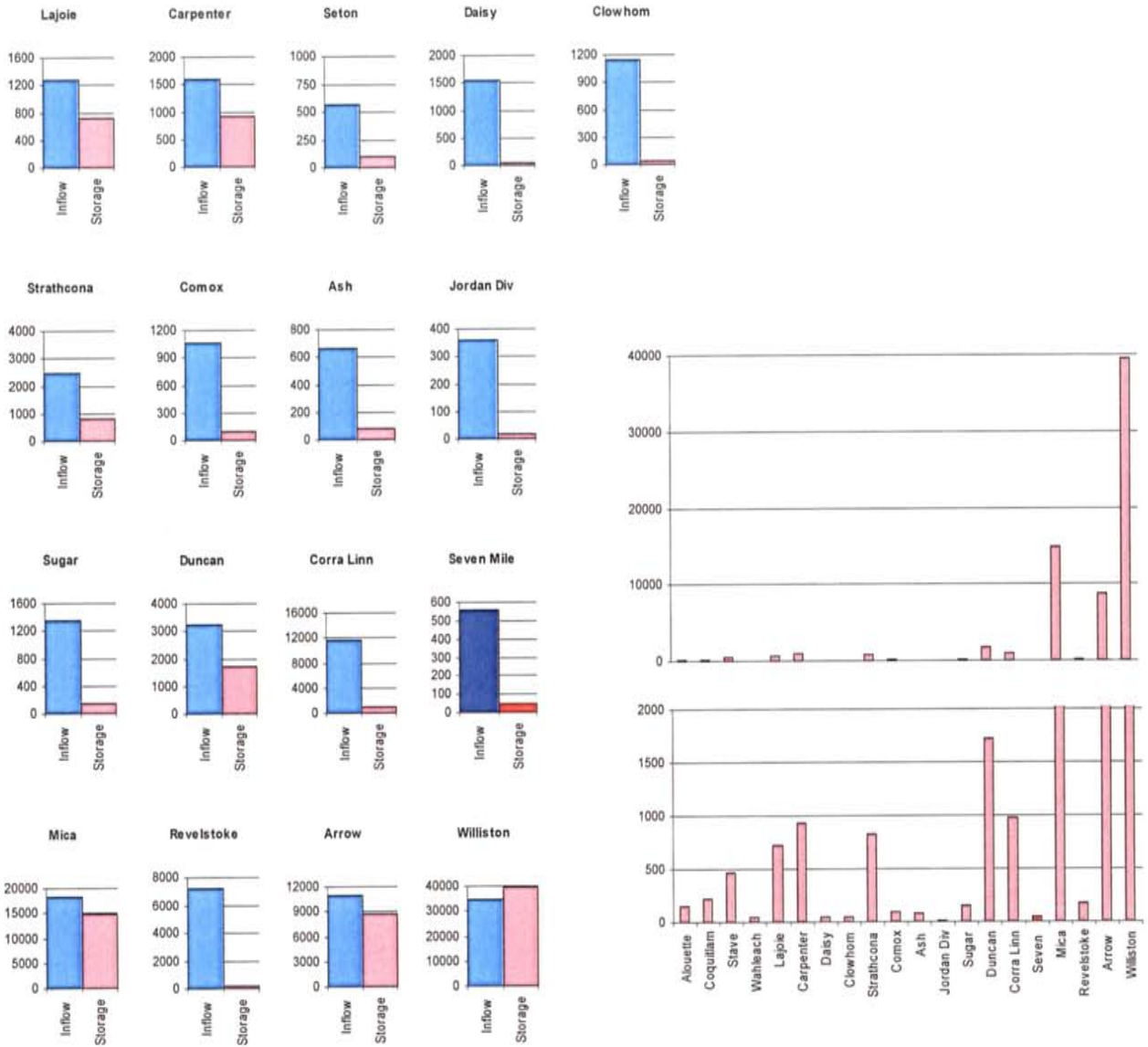

Figure 13: Comparison of project annual inflows to reservoir storage capacity

Prepared by:

S. Ebrahim  
S. Ebrahim, EIT

Reviewed by:

K. Groves  
K. Groves, P. Eng.