

Product Information Sheets

2000 edition:

WARNING

Readers should note that PIS pages are **NO LONGER VALID** for the following categories due to the introduction of the PQS system:

PIS E08 Injection devices since 30 June 2005
PIS E06 Temperature monitoring devices since 1 October 2007

All items that appear in PIS 2000 Edition WHO/V&B/00.13 sections E08 and E06 along with all items listed in WHO web site http://www.who.int/immunization_standards/vaccine_quality/new_sheets_intro/en/index.html under E06 category are no longer recommended by the WHO.

Readers should consult the following pages for PQS prequalified devices and equipment for E06 and E08 categories:

http://www.who.int/immunization_standards/vaccine_quality/pqs_prequalified_devices_e08/en/index.html
http://www.who.int/immunization_standards/vaccine_quality/pqs_prequalified_devices_e06/en/index.html



WORLD HEALTH ORGANIZATION
GENEVA

**The Expanded Programme on Immunization
of the Department of Vaccines and Biologicals
thanks the following donors whose unspecified financial support
in 1999/2000 has made the production of this document possible.**

This twelfth edition of the *Product Information Sheets*, revised in May 2000, has been produced by the Expanded Programme on Immunization in collaboration with the UNICEF Supply Division and two WHO Programmes: the Programme for Acute Respiratory Infections (ARI) and the Department of Blood Safety and Clinical Technology.

*Ordering code: WHO/V&B/00.13
Printed: June 2000*

This document is available on the Internet at:
www.who.int/vaccines-documents/

Copies may be requested from:
World Health Organization
Department of Vaccines and Biologicals
CH-1211 Geneva 27, Switzerland
• Fax: + 41 22 791 4192 • E-mail: vaccines@who.int •

© World Health Organization 2000

This document is not a formal publication of the World Health Organization (WHO), and all rights are reserved by the Organization. The document may, however, be freely reviewed, abstracted, reproduced and translated, in part or in whole, but not for sale nor for use in conjunction with commercial purposes.

The views expressed in documents by named authors are solely the responsibility of those authors.

Contents

<i>List of Product Information Sheets</i>	v
<i>Preface</i>	xi
<i>Glossary</i>	xx
<i>Abbreviations</i>	xxii

Expanded Programme on Immunization

General Information	1
1. Vaccine storage	3
2. How to estimate the cost of equipping a cold chain	7
3. Chlorofluorocarbons (CFC)	9
Section E1: Cold rooms for bulk storage of vaccines	13
1. Cold room buyers' guide	15
2. Standby generators buyers' guide	22
3. Voltage regulators for cold rooms	28
Section E2: Transport	31
1. Introduction	33
2. General purpose vehicles	33
3. Refrigerated vehicles	35
4. Motorcycles	38
<i>PIS Sheets</i>	41
Section E3: Refrigerators and freezers for storing vaccines and freezing icepacks	51
1. Choosing a refrigerator or freezer	53
2. Absorbtion refrigerators and freezers	58
3. Compression refrigerators and freezers	59
4. Solar refrigerator and freezer systems	61
5. Temperature zones	69
6. Guide to refrigerators and freezers (by type)	72
<i>PIS Sheets</i>	74
Section E4: Cold Boxes and vaccine carriers	115
1. Choosing a cold box or vaccine carrier	117
2. Criteria for the classification of cold boxes and vaccine carriers	118
3. Keeping vaccines cool during immunization sessions	118
4. Vaccine packaging for international transport of vaccine	119
<i>PIS Sheets</i>	120
Section E5: Icepacks	135
1. Introduction	137
<i>PIS Sheets</i>	138

Section E6: Thermometers, thermo-recorders and indicators	147
1. Temperature monitoring in the cold chain	149
<i>PIS Sheets</i>	150
Section E7: Accessories	161
1. Introduction.....	163
<i>PIS Sheets</i>	164
Section E8: Equipment for administration of vaccine and micronutrients	179
1. Injection equipment	181
2. Disposal of injection equipment.....	182
3. Injection safety.....	183
<i>PIS Sheets</i>	184
Section E9: Steam sterilizers	193
1. Introduction.....	195
<i>PIS Sheets</i>	196
Section E10: Injection accessories	211
1. Introduction.....	213
<i>PIS Sheets</i>	214
Section E11: Specimen collection equipment.....	219
1. Stool specimen collection for AFP	221
2. Send specimens via a “reverse cold chain”	221
3. Basic rules for specimen storage and transport	222
<i>PIS Sheets</i>	223
Section E12: Waste management	225
1. Introduction.....	227
<i>PIS Sheets</i>	228
Acute respiratory diseases	
Sections A1 & A2: Equipment for case management of acute respiratory infections	233
1. The oxygen concentrator	235
2. Respiratory rate timer.....	238
<i>PIS Sheet</i>	239
Cold boxes and carriers for blood transport	
Section B4: Cold boxes and carriers for blood transport	245
1. Introduction.....	247
<i>PIS Sheets</i>	248
Emergency campaigns	
Section EC: Equipment for emergency campaigns.....	251
1. Introduction.....	253
<i>PIS Sheets</i>	254
Primary health care	
Sections P7 and P8: Syringes, needles and accessories for primary health care	255
<i>PIS Sheets</i>	257
Index listing by manufacturer	259

List of Product Information Sheets

PIS code	Equipment	Manufacturer	Page
E2	Transport		
E2/07 V80 (4GC2)	Light on-road commuter type motorcycle: model Yamaha	J. Gerber & Company (Japan) Ltd.	41
E2/08	Light on/off-road motorcycle: model Yamaha AG100 (5HS1)	J. Gerber & Company (Japan) Ltd.	42
E2/09	Medium-light on/off-road motorcycle: model Honda CT11OP/DK	Honda Trading Corporation	43
E2/10	Light on-road motorcycle: model Suzuki A100 S	K. Arano & Co. Ltd. (Suzuki)	44
E2/11	Light on-road motorcycle: model Suzuki TF125W	K. Arano & Co. Ltd. (Suzuki)	45
E2/12 (3XN1)	Basic on-road commuter type motorcycle: Yamaha YB100	J. Gerber & Company (Japan) Ltd.	46
E2/13 (3TT4)	Light-Medium on/off road motorcycle: model Yamaha DT 125	J. Gerber & Company (Japan) Ltd.	47
E2/14 (3TS4)	Medium on/off road motorcycle: model Yamaha DT 175	J. Gerber & Company (Japan) Ltd.	48
E2/15 (3GXE)	Medium on/off road motorcycle: model Yamaha AG 200	J. Gerber & Company (Japan) Ltd.	49
E3	Refrigerators and freezers for storing vaccines and freezing icepacks		
E3/21-M (P) (920 5138 01)	Small refrigerator, absorption: model RCW 42 EG/CF (blue)	Electrolux (Luxembourg)	74
E3/22-M (blue) (P)	Small refrigerator, absorption: model RCW 42 EK/CF	Electrolux (Luxembourg)	75
E3/24-M (920 4251 07)	Ice-lined refrigerator, compression: model TCW 1152/CF	Electrolux (Luxembourg)	76
E3/30-M	Refrigerator & icepack freezer, electric, compression: RCW 42AC/CF (blue)	Electrolux (Luxembourg)	77
E3/31-M	Photovoltaic solar refrigerator & icepack freezer, compression RCW 42DC/CF (blue)	Electrolux (Luxembourg)	78
E3/37-M VR50F	Photovoltaic solar refrigerator & icepack freezer: model	BP Solar Ltd.	79
E3/57-M (New Generation)	Ice-lined refrigerator, compression type: model MK 144	Vestfrost A/S	80
E3/62-M	Ice-lined refrigerator & icepack freezer, compression type: model TCW 1990	Electrolux (Luxembourg)	81
E3/64-M	Ice-lined refrigerator and icepack freezer, compression type: model VC 139 F	LEC Refrigeration PLC	82
E3/65-M NRC 30-10	Photovoltaic solar refrigerator and icepack freezer: model	Norcoast Refrigeration Co.	83
E3/70-M CFS49 ISI	Photovoltaic solar refrigerator and icepack freezer: model	Fortum AES Norway AS	84
E3/72-M	Icepack freezer, absorption type: FCW 20 EG/CF (blue), electric and gas	Electrolux (Luxembourg)	85

PIS code	Equipment	Manufacturer	Page
E3/73-M	Icepack freezer, absorption type: FCW 20 EK/CF (blue), electric & kerosene	Electrolux (Luxembourg)	86
E3/75-M	Ice-lined refrigerator, compression type: model MK 074	Vestfrost A/S	87
E3/76	Solar thermal vaccine refrigerator and icepack freezer	Comesse Soudure SA	88
E3/77-M	Solar photovoltaic refrigerator / icepack freezer, compression type: RFVB-134a	Sun Frost	89
E3/79-M	Photovoltaic solar refrigerator and icepack freezer: model Dulas VC-150 F	Dulas Ltd.	90
E3/80-M	Icepack freezer, compression:TFW 800 (958.4575.10)	Electrolux (Luxembourg)	91
E3/81-M	Ice-lined refrigerator, compression type: model MK 204 (New Generation)	Vestfrost A/S	92
E3/82-M	Ice-lined refrigerator, compression type: model MK 304 (New Generation)	Vestfrost A/S	93
E3/83	Photovoltaic solar refrigerator & icepack freezer: model TBP VR 50	TATA BP Solar India Ltd.	94
E3/84-M	Refrigerator & freezer, absorption type: model V 170 GE gas and electric	Sibir International AB	95
E3/85-M	Refrigerator & freezer, absorption type: model V 170 KE kerosene and electric	Sibir International AB	96
E3/86-M	Refrigerator & freezer, absorption type: model V 110 GE gas and electric	Sibir International AB	97
E3/87-M	Refrigerator, absorption type: model V 110 KE kerosene and electric	Sibir International AB	98
E3/88-M	Refrigerator and icepack freezer, absorption: RCW 50 EG/CF (blue)	Electrolux (Luxembourg)	99
E3/89-M	Refrigerator & freezer, absorption type: model PR 245 K/E kerosene and electric	Zero Appliances	100
E3/90-M	Refrigerator & freezer, absorption type: model GR 245 G/E gas and electric	Zero Appliances	101
E3/91-M	Refrigerator and icepack freezer, absorption: RCW 50 EK (blue)	Electrolux (Luxembourg)	102
E3/92-M	Photovoltaic solar refrigerator and icepack freezer: model 120-30	Norcoast Refrigeration Co.	103
E3/93-M	Photovoltaic solar refrigerator & icepack freezer, compression RCW 50DG/CF(blue)	Electrolux (Luxembourg)	104
E3/94-M	Refrigerator and icepack freezer, compression: RCW 50 AC (blue)	Electrolux (Luxembourg)	105
E3/95-M	Ice pack freezer, absorption type: model PF 230 IP kerosene and electric	Zero Appliances	106
E3/96-M	Vaccine/icepack chest freezer, compression type: model MF 114 (New Generation)	Vestfrost A/S	107
E3/97-M	Vaccine/icepack chest freezer, compression type: model MF 214 (New Generation)	Vestfrost A/S	108
E3/98-M	Vaccine/icepack chest freezer, compression type: model MF 314 (New Generation)	Vestfrost A/S	109
E3/99-M	Vaccine/icepack chest freezer, compression type: Model FCW 200	Electrolux (Luxembourg)	110
E3/100-M	Vaccine/icepack chest freezer, compression type: Model FCW 300	Electrolux (Luxembourg)	111
E3/101-M	Photovoltaic solar refrigerator and icepack freezer, compression: model PVR 150	Solamatics	112
E3/102-M	Refrigerator and icepack freezer, compression: GR265D, kerosene and electric	Zero	113

PIS code	Equipment	Manufacturer	Page
E4	Cold boxes and vaccine carriers		
E4/05-M (blue)(991.1537.01)	Large vaccine cold box, long range: model RCW 25/CF	Electrolux (Luxembourg)	120
E4/09	Large vaccine cold box, short range: model CB/INO/B3/90	Ina ColdMed	120
E4/10	Small vaccine cold box, short range: model CB/INO/C2/90	Ina ColdMed	121
E4/18-M	Large vaccine carrier: model 3504 UN/CF	The Thermos Company	121
E4/20	Small vaccine cold box, short range: model CB/INO/D1/90	Ina ColdMed	122
E4/22	Small vaccine cold box, long range	Oyster Industries (Pvt.) Ltd.	122
E4/34	Large vaccine carrier: model IA	Beijing Light Industrial Prod.	123
E4/37-M	Large vaccine cold box, long range: model KR 48	Savopak Oy	123
E4/52-M	Large vaccine carrier	Gio StyleSpa	124
E4/53-M	Small vaccine carrier model RCW 2/CF (991.5903.01)	Electrolux (Luxembourg)	124
E4/55-M	Small Vaccine Carrier: model T.P.001	True Pack Ltd.	125
E4/57-M	Small vaccine cold box, short range: model 55-CF	Blow Kings	125
E4/62-M (991 7701 01)	Small vaccine cold box, long range: model RCW 12/CF	Electrolux (Luxembourg)	126
E4/67-M	Large Vaccine carrier model IVC-9AF	Apex Continental Limited	126
E4/68-M	Small vaccine carrier: model IVC-8F	Apex Continental Limited	127
E4/69-M	Small vaccine carrier: model VDC-24-CF	Blow Kings	127
E4/72-M	Large vaccine cold box, long range: model ICB-11F	Apex Continental Limited	128
E4/75-M	Small vaccine cold box, long range: model ICB-8F	Apex Continental Limited	128
E4/76-M	Large vaccine cold box, long range: model CB/20/5U -CF	Blow Kings	129
E4/77-M	Large vaccine carrier: model VC/42/MOD/2/CF	Blow Kings	129
E4/78-M	Small vaccine cold box, long range: model CB/5/2A/CF	Blow Kings	130
E4/79	Small vaccine carrier	Promociones LISA S.A.	130
E4/80-M	Small vaccine cold box, short range: model 390	Polyfoam Packers Corp.	131
E4/81-M	Large vaccine carrier (blue): model: CFC free	Nylex Packaging PTY Ltd.	131
E4/83-M	Large vaccine carrier: :model BK-VC 1.6 - CF	Blow Kings	132
E4/84-M	Vaccine carrier for NID: model Frigivac for Kick Polio	CIP Industries	132
E4/85-M (958.4802.01)	Small vaccine cold box, short range: model RCW 8/CF	Electrolux (Luxembourg)	133
E4/86-M	Large vaccine cold box, short range: model ICB-14F	Apex Continental Limited	133
E4/87-M	Large vaccine cold box, short range: model LCB-8A	Beijing Cold-Chain Co.Ltd	134
E4/88-M	Large vaccine carrier: :model CB/10-CF	Blow Kings	134
E5	Icepacks		
E5/04	Icepack, 0.6 litre (Reference 38095): model 600, Isa Polar Maxi	Runsven AB	138
E5/06	Icepack, 0.4 litre	Beijing Light Industrial Prod.	138
E5/08	Icepack, 0.3 litre	Electrolux (Luxembourg)	139
E5/09	Icepack, 0.6 litre	Electrolux (Luxembourg)	139
E5/10	Icepack, 0.4 litre model 400 CC	Gio Style SPA	140
E5/12	Icepack, 0.3 litre model BK-V4 H	Blow Kings	140
E5/14	Icepack, 0.4 litre model reference: 38197	Runsven AB	141
E5/15	Icepack, 0.3 litre	Apex Continental Limited	141
E5/16	Icepack 0.6 litre	Gio Style SPA	142
E5/17	Icepack, 0.4 litre	Garnia / Lameplast	142
E5/19	Icepack, 0.4 litre model BK-4	Blow Kings	143
E5/20	Icepack, 0.4 litre	Apex Continental Limited	143

PIS code	Equipment	Manufacturer	Page
E5/21	Icepack, 0.6 litre	Apex Continental Limited	144
E5/22	Icepack, 0.4 litre	Beijing Cold-Chain Co.Ltd	144
E5/23	Icepack, 0.6 litre model BK-6	Blow Kings	145
E6	Thermometers, thermo-recorders and indicators		
E6/08	Vertical hanging vaccine thermometer: model 66/381/0	S. Brannan & Sons Ltd.	150
E6/09	Recording thermometer: model 615.WHO*, 7 day, -40 to +70°C	Pacific Transducer Corp.	150
E6/11	Waterproof liquid crystal thermometer: model 2290	Hallcrest Inc.	151
E6/15	DT & TT Shipping indicator	Berlinger & Co. AG	151
E6/16	Vaccine cold chain monitor card	Berlinger & Co. AG	152
E6/26	Bimetal vaccine thermometer: model 102475	Möeller-Therm GmbH	152
E6/27	Alcohol stem thermometer: model 104614	Möeller-Therm GmbH	153
E6/28	Recording thermometer: model AR10-GT-S	Hyoda Instruments Corporation	153
E6/29	Dial thermometer: model TFH 100 iF 1 + K1 .21 + ma	Rueger S.A.	154
E6/30	Vaccine thermometer: model TSH 065 F	Rueger S.A.	154
E6/32	Digital thermometer: model MT 160C	Tempcontrol I.E.P. B.V.	155
E6/35	Dial thermometer: model 10 259-04	Armatherm Gunthel GmbH	155
E6/36	Dial thermometer: model 704 KG 100	Teck Instruments.	156
E6/38	Temperature recorder: model 13021.12	Jules Richard Instruments	156
E6/39	Recording thermometer: model EPI/RFBD	Foundrometers Instr. Ltd.	157
E6/42	Temperature data logger — TempTale	TSS AB	157
E6/43	Temperature data logger: model small TTMTType G	Remonsys Ltd.	158
E6/44	Temperature data logger: model small TTMG IP68	Remonsys Ltd.	158
E6/45	Freeze watch indicator (0°C): model recorder number:9805	Berlinger & Co. AG	159
E6/46	Stop! Watch Refrigerator monitor, (0°C)	Berlinger & Co. AG	159
E6/47	Temperature data logger: AUTOLOG 2000 TM	Remonsys Ltd.	160
E6/48	Temperature data logger: Thermo-Tracer	OCEASOFT	160
E7	Accessories		
E7/08	Surface level: model SM100	Johnson Level & Tool Manuf.	164
E7/10	Vaccine packaging tape	Papeteries Mertens Sprl.	164
E7/11	Voltage regulator for compression refrigerators: model FF 500/4R	Advance Galatrek	165
E7/12	Voltage regulator for absorption refrigerators: model FF 500/PA	Advance Galatrek	165
E7/13	Fibreglass wick for kerosene burner	Silver Trading Company Ltd.	166
E7/26 or R134A	Refrigerator/freezer universal spare parts kits for RCFC-12	H. Jessen Jürgensen A/S	166
E7/37	Tool kit for RCW 42 range of refrigerators	Electrolux (Luxembourg)	167
E7/38	Mains voltage compensator for compr. refig.: model MVC-2W S1775	Claude Lyons Limited	167
E7/39	Mains voltage compensator for absorp. refig.: model MVC-IN S1776	Claude Lyons Limited	168
E7/42	gas conversion kit for RCW 42 EK/CF refig. & freezer: model no. 991.1861.01/2	Electrolux (Luxembourg)	168
E7/43	Manual gas changeover valve: model 02 060-00 (prop. & butane gas)	GOK	169
E7/44	Upgrade kit for RCW 42 EK/CF freezer and refrigerator: model no. 991.1860.01	Electrolux (Luxembourg)	169
E7/51	Modification kit to upgrade domestic refrigerators for vaccine storage	Universidad del Valle	170

PIS code	Equipment	Manufacturer	Page
E7/52	Cotton wicks for kerosene burners	Aladdin Sales and Marketing	170
E7/54	Basic tool kit for refrigerator technician for CFC-12 and HFC-134A systems, 220V**	Vestfrost A/S	171
E7/55	Supplementary refrigerator toolkit for CFC-12 systems only	Vestfrost A/S	172
E7/56	Supplementary refrigerator toolkit for HFC-134A systems only	Vestfrost A/S	173
E7/57	Complete refrigerator Lokring kit AKK110	Vestfrost A/S	174
E7/58	Basic tool kit for refrigerator technician for CFC-12 and HFC-134A systems, 220V**	H. Jessen Jürgensen A/S	175
E7/59	Supplementary refrigerator toolkit for CFC-12 systems only	H. Jessen Jürgensen A/S	176
E7/60	Supplementary refrigerator toolkit for HFC-134A systems only	H. Jessen Jürgensen A/S	177
E7/61	Complete refrigerator Lokring kit AKK110	H. Jessen Jürgensen A/S	178
E8	Equipment for administration of vaccine and micronutrients		
E8/01	Sterilizable plastic syringe, 0.05 ml	CODAN	184
E8/03	Sterilizable plastic syringe, 5.0 ml	CODAN	184
E8/04	Sterilizable plastic syringe, 0.05 ml	Sedat S.A.	185
E8/05	Sterilizable plastic syringe, 0.5 ml	CODAN	185
E8/06	Sterilizable plastic syringe, 0.5 ml	Sedat S.A.	186
E8/07	Sterilizable syringe Kit A	UNICEF (Denmark)	186
E8/08	Sterilizable syringe Kit B	UNICEF (Denmark)	187
E8/09	Autodisable syringe, 0.5 ml Soloshot (TM)	BD Medical Systems	187
E8/10	Autodisable syringe, 0.5 ml: DestroJect	DestroJect GmbH	188
E8/11	Pump dispenser for micronutrients: model Englass Swift "OR"	Englass Disp. & Packaging	188
E8/12	Autodisable syringe, 0.5 ml	UNIVÉC	189
E8/17	Autodisable syringe, 0.5 ml Soloshot (TM) FX	BD Medical Systems	189
E8/18	Autodisable syringe, 0.05 ml	UNIVÉC	190
E8/19	Autodisable syringe, 0.5 ml	Star Syringe Limited	190
E8/20	Autodisable syringe, 0.05 ml	Star Syringe Limited	191
E9	Steam sterilizers		
E9/01	Single rack steam sterilizer: model 750900	Prestige Medical Ltd.	196
E9/02	Double rack steam sterilizer: model 750600	Prestige Medical Ltd.	197
E9/03	Single rack steam sterilizer: model CertoClav KC 5L, 85.016.05	Certoclav Sterilizer GmbH	198
E9/04	Triple rack steam sterilizer: model 750500	Prestige Medical Ltd.	199
E9/05	Double rack steam sterilizer: model CertoClav KC 8L, 85.016.08	Certoclav Sterilizer GmbH	200
E9/07	Double rack electric steam sterilizer: model 210005 (220/240V)	Prestige Medical Ltd.	201
E9/08	Sterilizer Kit A	UNICEF (Denmark)	202
E9/09	Sterilizer Kit B	UNICEF (Denmark)	203
E9/13	Multi purpose double rack sterilizer: model 750300	Prestige Medical Ltd.	204
E9/14	Thermal solar steam sterilizer	TriSolar Foundation Trust	205
E9/15	Sterilization module: 15 l	MSF Logistique	206
E9/18	Single rack steam sterilizer: model UAP121	ALMAS	207
E9/19	Single rack steam sterilizer: model XS22 and XS22A	Zhejiang Supor Co. Ltd.	208
E9/20	Double rack steam sterilizer: model XD22 and XD22A	Zhejiang Supor Co. Ltd.	209
E9/21	Double rack electric steam sterilizer: model XKD22-110A	Zhejiang Supor Co. Ltd.	210
E10	Injection accessories		
E10/03	Hard water pad: model 751300	Prestige Medical Ltd.	214
E10/04	Hard water pad: model Sant 0.7	Dac	214
E10/06	TST indicator strips	Albert Browne Ltd.	215

PIS code	Equipment	Manufacturer	Page
E10/07	TST control spot & record system for steam sterilizer working at 121°C for 15'	Albert Browne Ltd.	215
E10/09	Sterilizer drum	Galeno A.M.S S.r.l.	216
E10/10	Sterilizer drum, single rack: model TD	TriSolar Foundation Trust	216
E10/11	Sterilizer drum, single rack: model ED	TriSolar Foundation Trust	217
E10/12	Sterilizer drum, double rack: model TDR	TriSolar Foundation Trust	217
E11	Specimen collection equipment		
E11/02	Polio specimen collection kit	Medical Export Group	223
E11/05-M	Specimen carrier (yellow): model: CFC free	Nylex Packaging PTY Ltd.	223
E12	Waste Management		
E12/01	Safety box for the disposal of used syringes and needles, 5 l	Pa-Hu OY	228
E12/02	Safety box & incineration container for disposal of syringes and needles, 5 l	POLYNOR	228
E12/03	Safety box for the disposal of used syringes and needles, 5& 10 l	CIP Industries	229
E12/04	Safety box for the disposal of used syringes and needles, 5 l	Danapak Cartons Ltd.	229
E12/05	Needle destroyer - electric: model ND2	Healthcare Products Plus, Inc.	230
E12/06	Needle and Syringe destroyer - manual	Balcan Engineering Limited.	230
E12/07	Safety box for the disposal of used syringes and needles, 5 l	Atlas Medical Resources	231
E12/08	Safety box for the disposal of used syringes and needles, 10 l	POLYNOR	231
E12/09	Safety box for the disposal of used syringes and needles, 20 l	POLYNOR	232
A1 & 2	Equipment for case management of acute respiratory infections		
A1/01	Oxygen Concentrator: DeVibiss model 515 KS	Sunrise Medical Ltd.	239
A1/02	Oxygen Concentrator: Companion Aeris 590 Concentrator with OCI model C-495011	Mallinckrodt UK Ltd	240
A1/03	Oxygen Concentrator:Millennium	Respironics International	241
A2/01	Respiratory rate timer (ARI Timer)	UNICEF (Denmark)	242
A2/02	Nebuliser Pump including Spares Kit	Cameron-Price Medical Div.	243
B4	Cold boxes and vaccine carriers for blood transport		
B4/05-M	Large blood cold box, long range: model RCW 25/CF(blue) (991.1510.2)	Electrolux (Luxembourg)	248
B4/18-M	Large blood carrier: model 3504/38/CF	The Thermos Company	248
B4/57-M	Small blood cold box, short range: model 55-CF	Blow Kings	249
B4/62-M	Small blood cold box, short range: model RCW 12/CF (991 7701 01)	Electrolux (Luxembourg)	249
B4/72-M	Large blood cold box, long range: model ICBB-13F	Apex Continental Limited	250
B4/76-M	Large blood cold box, long range: model CB/20/5U-CF	Blow Kings	250
EC	Equipment for emergency campaigns		
EC1/01	Immunization kit: 10 000 injections	MSF Logistique	254
P7 & 8	Syringe, needles and accessories for primary health care		
P7/01	Electronic mother/child care scale: model UNIScale	UNICEF (Denmark)	257
P8/01	Autodestruct syringe, 2.0 ml	Atlas Medical Resources	257

Preface

This is the twelfth edition of the Product Information Sheets, produced by the WHO Expanded Programme on Immunization (a team of the Department of Vaccines and Biologicals) in collaboration with the Supply Division of UNICEF (Copenhagen) on a regular basis since 1979. This publication provides general information on the choice of equipment, together with specific technical and purchasing data for individual selected items.

The Product Information Sheets was formerly concerned only with equipment for the EPI. From the 1993/94 edition onwards the scope was expanded. This edition includes equipment from the programme to reduce Acute Respiratory Infections (ARI) as well as equipment to be used in emergency campaigns and for other primary health care initiatives. This edition includes a section B4, *Cold Boxes and carriers for blood transport*. It is envisaged that this section will not appear in future editions as WHO's Department of Blood Safety and Clinical Technology is planning to produce a comprehensive blood safety equipment publication by the end 2000.

For the EPI, this edition includes the standard selection of cold chain equipment for the storage, transport and administration of vaccines, as well as equipment for the collection and transport of stool specimens for the isolation of polio virus.

A new section, Waste Disposal, has been added to this edition. This section includes all the previously listed safety products from the E10 Injection Accessory section, and some new products. These products have been given their own section in order to highlight the importance of safe injections in immunization services, a priority project of WHO.

The criteria for inclusion is that each item of equipment must be independently tested in accordance with standard test procedures and found to meet established specifications for performance.

For the EPI equipment, standards for performance and testing are contained in a series of WHO/EPI documents, *Equipment performance specifications and test procedures* (WHO/EPI/LHIS/97.03-14 and on the web at www.who.int/vaccines-access/pis.htm). Prepared for use by manufacturers in the international market, these publications provide clearly defined blueprints for the production of equipment that will meet the highest competitive standards of reliability and performance in the EPI.

Future work on standards

For the last 20 years, vaccine cold chain systems have been built and maintained on the basis of a single set of rules governing vaccine handling worldwide, regardless of the local environment or the type of vaccine. This approach had the merit of simplicity, making the cold chain easy to understand, implement and manage, and a non-controversial, concrete objective to achieve.

This simplicity has gradually turned into a global “cold chain dogma”. It was however made necessary at a time when the EPI management and infrastructure were being established and because it was impossible to check whether vaccines retained adequate potency during distribution. Today, immunization programmes have evolved and have diversified in terms of operational strategy reaching out to inaccessible areas, covering large target populations in special campaigns and seeking every opportunity to reach the last 20% of children unprotected by immunization. Vaccines themselves have become more stable.

The advent of the vaccine vial monitor (VVM) will allow the management of immunization programmes to exploit the full extent of the stability of each vaccine, to minimise the cost of the distribution system and to enjoy a new flexibility in the handling of vaccine in the field. All these changes should help make immunization operations more effective. The benefits of the VVM have been proved with Polio vaccine. The VVM will be introduced into on the five other EPI antigens, on all vaccine supplied through UNICEF supplies division, by the end of 2000.

In addition to the VVM “revolution”, global changes are now affecting the cold chain: socioeconomic and financial changes as well as technical and programmatic changes. The cold chain in every immunization programme will be affected by these changes.

Changes in the global standards established over the past two decades are therefore needed and work will be on-going at WHO in collaboration with all major partners in immunization to propose a new set of cold chain management and vaccine handling rules. These will probably rely, to a great extent but not entirely, on a broad implementation of VVMs into immunization programmes worldwide. They will also assume that global cold chain standards are no longer adapted to the level of sophistication that immunization programmes have reached and that standards now need to be better adjusted to the specifics of the area, country or region such as climate and availability of reliable power supply.

It is intended that this “Vision of the future cold chain” be further developed, through consultation with TECHNET, a global network of immunization logistics and cold chain experts, with programme managers and donor agencies.

The biggest development for this issue of the PIS is in the area of temperature zones. For the first time refrigerators and freezers are classified by temperature zone. The previous approach of one standard based on a single worst case scenario needed to be revised. These standards did not keep into account the real ambient temperatures that appliances are submitted to. All refrigerators and freezers are now classified on the basis of their performance in specific temperature zones (see Section E3).

Coding:

- A reference number, the PIS Code, is assigned to each item. This number remains constant from issue to issue and is never reassigned to another item. Breaks in the chronological order exist where items have been dropped. The exception to this rule is with the new E12 section. Items formerly in section E10 that have been moved to E12 have been re-coded.
- When an order is placed be as specific as possible: give the PIS code and add manufacturers code if the latter is given and the full product description. This may prevent unnecessary delay. Many products come with various options. Clearly state the options required.
- If a product has various specifications make sure that the exact specification required is clearly stated along with the PIS code in the order.
- In the E3 and E4 sections of this edition, CFC-free versions of items listed in the previous editions (with CFC) have kept the same PIS code with the addition of the letter “M”. This letter warns the readers that:
 - These items meet the Montreal Protocol regulations (they do not contain any CFCs)
 - Although these items have the same physical characteristics as the previous versions with CFCs, some of the performance may have changed (power consumption, holdover time, old life)

User’s contribution

Suggestions for improving the quality and presentation of the Product Information Sheets will be welcomed by EPI/Geneva. Comments on field experience with PIS equipment, as well as information on new equipment, would also be useful.

Disclaimer

The inclusion of products in the Product Information Sheets signifies their technical acceptability for use in immunization programmes. It in no way implies an endorsement or promotion of the companies making these products.

Prices, shipping/freight costs, and INCO terms

- The prices listed are indicative. They are valid from May 2000. For prices that are quoted in other currencies, the dollar equivalent is given. This figure has been calculated on the basis of the May 2000 exchange rate (see table below).
- Shipping/freight costs vary considerably according to destination and are not included with the product costs in this document. Purchasers must budget for this additional charge when placing an order. Freight costs must be included in budgets, and freight times must be included in project plans. Purchasers must calculate the freight costs and freight times before placing an order.

Shipping advice is available from the WHO Shipping and Logistics unit (see the next section for contact details).

- Manufactures/suppliers offer different sales/delivery conditions for their products. Special terms, based on international standards known as INCO terms, are used to express the conditions of sale. Purchasers must be aware of what these terms mean for them as purchasers. The INCO term is stated in the price information section of each sheet.

Definitions:

- EXW:** Ex Works: means the seller delivers when he places the goods at the disposal of the buyer at the sellers premises or another named place, not cleared for export and not loaded on a collecting vehicle. This term therefore represents the minimum obligation for the seller. All export documents are the responsibility of the purchaser. The purchaser is responsible for all costs and risks, including insurance, on collection of the goods.
- FCA:** Free Carrier: means the seller delivers the goods, cleared for export, to the transporter nominated by the buyer. The purchaser is, however, responsible for all costs and risks, including insurance, of the goods.
- FOB:** Free on Board: means that the seller delivers, cleared for export, when the goods pass the ships rail. The purchaser is responsible for all costs and risks, including insurance, once the goods have passed the ships rail.
- FOT:** Free on Truck: Although still quoted by some companies in this publication this is no longer an INCO term. In general FCA has replaced it. When purchasing goods from companies still stating the FOT INCO term make sure that a correct term is used before a contract is signed.

Currency exchange rates as of 1 May 2000

Country	Currency name	Currency abbreviation	Exchange rate to US\$ 1
Austria	Schilling	ATS	14.38
Denmark	Kroner	DKK	8.19
European Union	Euro	XEU	1.10
Finland	Markka	FIM	6.27
France	Franc	FRF	6.86
Germany	Mark	DEM	2.05
Italy	Lire	ITL	2024.98
Japan	Yen	JPY	107.95
Netherlands	Guilder	NLG	2.31
Norway	Kroner	NOK	8.94
Sweden	Kroner	SEK	8.93
Switzerland	Franc	CHF	1.72
United Kingdom	Pound	GBP	0.64

Suppliers & contacts

Orders can be placed with the manufacturer whose address is given below every item in the sheets. Alternatively, most items can be purchased through WHO or UNICEF. Additionally vehicles, motorbikes and power products can be purchased through the Inter-Agency Procurement Services Office (UNDP/IAPSO). Secondary suppliers, who have equipment in stock and/or through whom orders can be placed include: International Dispensary Association (IDA) in The Netherlands and Médecins Sans Frontières Logistique (MSFL) in France. The table on page XIII shows the items IDA and MSFL can supply and/or have in stock.

Inter-Agency Procurement Services Office (UNDP/IAPSO)

Midtermolen 3

P O Box 2530

DK-2100 Copenhagen Ø

Denmark

Telephone: +45(35 46 70 00

Fax: +45 35 46 70 01

E-mail: registry@iapso.org

For vehicles copy: lisa.rones@iapso.org

For other equipment also copy: sharon.sorensen@iapso.org

International Dispensary Association (IDA)

Sales and Marketing

PO Box 37098

NL-1030 AB Amsterdam

The Netherlands

Telephone: +31 20 403 30 51

Fax: +31 20 403 18 54

E-mail: info@ida.nl

Médecins Sans Frontières Logistique

14 Av. de l'Argonne

F-33700 Bordeaux, Mérignac

France

Telephone: +33 5 56 13 73 73

Fax: +33 5 56 13 73 74

E-mail: standard@bordeaux.msf.org

UNICEF**UNICEF Plads****Freeport****DK-2100 Copenhagen 0****Denmark***Telephone: +45 35 27 35 27**Fax: +45 35 26 94 21**E-mail: supply@unicef.dk***World Health Organization****Procurement Services****20 Avenue Appia****CH-1211 Geneva 27****Switzerland***Telephone: +41 22 791 28 01**Fax: +41 22 791 41 96**E-mail: procurement@who.int***Department of Vaccines and Biologicals****Document Centre****20 Avenue Appia****CH-1211 Geneva 27****Switzerland***Fax: +41 22 791 41 92**E-mail: vaccines@who.int***Shipping and Logistics Services****20 Avenue Appia****CH-1211 Geneva 27****Switzerland***Telephone: +41 22 791 21 94**Fax: +41 22 791 48 37/41 96**E-mail: allamana@who.int*

**Suppliers of cold chain equipment other than UNICEF,
WHO and the manufacturers**

PIS Code	Item	MSFL Stock	IDA Stock
E3	Refrigerators and freezers		
E3/28-M	Refrigerator & freezer, absorption type Model V 240 KE/CP Kerosene and electr.	PCOLFRIF2KE	X
E3/29-M	Refrigerator & freezer, absorption type Model V 240 GE/CP Gas and Electric	PCOLFRIF2GE	X
E3/37	Photovoltaic solar refrigerator & icepack freezer: Model VR 50		X
E4	Cold boxes and vaccine carriers		
E4/05-M	Long range vaccine cold box Model RCW 25/CF	PCOLBOXC22E	
E4/18-M	Vaccine carrier Model 3504 UN/CF	PCOLBOXC02T	X
E4/29-M	Large vaccine cold box, short range Model 2417x31, 72 Qt. Legend		X
E4/62-M	Long range vaccine cold box Model RCW 12/CF	PCOLBOXC08E	
E4/73-M	Small cold box, short range Model Tag Along 24, 168-901x12		X
E4/74-M	Large vaccine carrier, Tag Along, 10 Model 88-901x8		X
E5	Icepacks		
E5/09	Vaccine icepack Model 0.6 litre	PCOLPACK06E	
E6	Thermometers, thermo-recorders and indicators		
E6/15	DT & TT Shipping indicator		X
E6/16	Vaccine cold chain monitor card (English)	PCOLCONT1CE	X
E6/16	Vaccine cold chain monitor card (French)	PCOLCONT1CF	X
E6/26	Bimetal vaccine thermometer	PCOLTHER2B-	
E6/27	Alcohol stem thermometer	PCOLTHER1A-	
E6/45	Freeze watch indicator	PCOLCONT3FI	
E6/46	STOP!Watch — Refrigerator monitor	PCOLCONT2R-	X

Suppliers of cold chain equipment (continued)

PIS Code	Item	MSFL Stock	IDA Stock
E8	Needles and syringes		
E8/01	0.05 ml. sterilizable plastic syringe		X
E8/03	5.0 ml sterilizable plastic recap syringe		X
E8/05	0.5 ml. sterilizable plastic recap syringe		X
E9	Steam Sterilizers		
E9/01	Single rack steam sterilizer		X
E9/02	Double rack steam sterilizer		X
E9/04	Triple rack steam sterilizer		X
E9/07	Double rack electric steam pressure sterilizer (220/240V)		X
E9/13	Multi purpose double rack sterilizer		X
E10	Injection accessories		
E10/03	Hard water pad		X
B4	Cold boxes and carriers for blood transport		
B4/18-M	Blood carrier. Model 3504/38/CF		X
B4/29-M	Large blood cold box, short range. Model 2417 x 3l, 72 Qt. Legend		X

Glossary

The following list of definitions is designed to explain essential terms used for the specification of equipment. It is not exhaustive: only those terms, which are not part of common knowledge, and for which a correct interpretation is essential to make a choice are included.

All specifications have to meet the standards that are defined in the *Equipment performance specifications and test procedures series* (WHO/EPI/LHIS/97.03-14).

Vaccine storage capacity

The vaccine storage capacity is a measure of the net space in a refrigerator, freezer, cold box or vaccine carrier available for the storage of vaccines. It is measured in the following ways:

- **Refrigerators:** a load of vaccine boxes of 100x100x100mm or 100x100x50mm is packed in the refrigerator with air space of 15 mm between each column of packets and between the packets and any adjoining wall.
- **Freezers:** the same vaccine boxes are used as above, but no space is left between the boxes or the walls.
- **Cold boxes:** vaccine storage capacity is obtained by multiplying the vaccine storage dimensions, i.e. the gross internal volume minus the volume taken by the icepacks.

Icepack freezing capacity (kgs per hr)

The icepack freezing capacity is a measure of the capacity of a freezer or of the freezer compartment of a refrigerator to freeze a certain quantity of ice (in standard size icepacks) in a certain number of hours in one freezing cycle, while maintaining the temperature of the full vaccine load within the recommended range of 0 to 8°C for refrigerating compartments or -5°C for vaccine/icepack freezers. It is measured as follows:

- Absorption refrigerators/freezers and icepack freezers:
 - the quantity of icepacks frozen in 24 hrs.
- Compression chest freezers:
 - without vaccines: the time is measured to freeze a quantity of icepacks that occupies at least one third of the internal gross volume and the whole of the fast freeze area. With respect to the minimum, the manufacturer decides the quantity actually frozen;
 - with vaccines: the quantity of ice frozen in 24 hrs while maintaining the temperature of the full vaccine load within the recommended range (0 to 8°C or -15°C for vaccine freezers).
- Compression refrigerators and freezers combined (not ice lined) and Solar (PV) refrigerator/icepacks freezer: the quantity of ice frozen in 24 hrs.
- Icepack fast freezers: the time is measured to freeze a full load of icepacks, arranged in the way the manufacturer recommends, or if not given, whichever way seems to give the best result.
- Icelined refrigerator and/or freezer: there is no standard minimum capacity for these appliances. The quantity to freeze in the test is decided by the manufacturer.

Due to the way icepack freezing capacity is presently measured, the quantity given in the PIS does not always refer to a 24 hours cycle. If one wants to extrapolate available data to a 24 hours cycle, the following points must be considered:

- The given quantity may correspond to the actual size of the freezing compartment.
- If the number of hours given exceeds 24, the quantity of ice may be proportionally decreased to obtain the quantity per 24 hrs.
- If the number of hours given is less than 24 *a proportional increase is usually an overestimation.*

Holdover time during power cut

This measurement indicates the ability of the appliance to maintain the vaccine load within the recommended temperature range when power supply has been interrupted. It is measured as the time between switching off the appliance and when the warmest internal temperature reaches +10°C for refrigerators and freezers at a given ambient temperature. In order to calculate the minimum holdover time, the electricity supply is switched off at the start of a new compressor cycle.

Cold life

The interval of time between the moment the coldest point in the load passes -3°C until the temperature of the warmest point reaches +10°C, at a given ambient temperature (usually 43°C).

Abbreviations

()	performance data as reported by manufacturer
[]	estimated
—	information not applicable or not available
++	not tested
“	inch
A	ampere
AC	alternating current
BCG	bacille Calmette-Guérin vaccine (for tuberculosis)
CATR	Consumer Research Laboratory (previous abbreviation)
cc	cubic centimetre
CCIS	cold chain information series
m ³	cubic metre
CFC	chloro-fluoro-carbon
cm	centimetre
CIF	cost, insurance and freight
CRL	Consumer Research Laboratory (current abbreviation)
dB(A)	decibels
DC	direct current
DTP	diphtheria-tetanus-pertussis vaccine
DT	diphtheria and tetanus toxoids
°C	degrees celsius (centigrade)
EDA	expected date of arrival
ETO	ethylene oxide
FCA	free carrier or agent
FOB	free on board
FOT	free on truck
g	grams
G	gauge
H x W x L(D)	height by width by length (depth)
HDPE	high density polyethylene
Hib	<i>Haemophilus influenzae b</i>
HIP	high impact polystyrene

HP	horsepower
hrs.	hours
Hz	hertz (cycles per second)
id	inner diameter
IPV	inactivated polio vaccine
kgs	kilograms
km	kilometre
KPA	kilo Pascals (100 KPA = 1 Bar = 14.5 psi)
KVA	kilovolt-ampere
Kwh	kilowatt-hours
lb	pound (weight)
LLDPE	linear low density polyethylene
LP gas	liquid propane gas
LPM	litres per minute
lts or l	litres
M	In sections E3 and E4 the suffix M is included in the product code to indicate the product is CFC free and complies with the conditions of the Montreal Protocol.
m	metre
max	maximum
min	minimum
mfg.	manufacturer
ml	millilitre
mm	millimetre
No.	number
od	outer diameter
OPV	oral polio vaccine
POA	price on asking
psi	pounds per square inch
PVC	polyvinyl chloride plastic
PW	peak watt
RH	relative humidity
RPM	revolutions per minute
TT	tetanus toxoid
V	volt
VAC	voltage alternating current
VDC	voltage direct current
W	Watt
≥	greater then or equal to
≤	less then or equal to

Section E (E1-E12)

Expanded Programme on Immunization

General information

1. Vaccine storage

Table 1: Recommended temperatures and storage times at different stages of the cold chain

Vaccine	Central storage with electricity: up to 6 months	Regional storage with electricity: up to 3 months	District and Health Centre storage with or without electricity: up to 1 month
Oral polio Yellow fever	-15°C to -25°C		
Measles BCG*	-15°C to -25°C or 0°C to +8°C		
IPV DTP DT TT Hepatitis B Hib	0°C to +8°C		

* **Warning:** do not freeze BCG if the diluent is included in the packaging

- Storage times given in the above table are recommended maximum figures. Remember to check expiry dates.
- At any stage of the cold chain, vaccine is transported at 0 to +8°C. Polio vaccine may be thawed and frozen again without danger to the vaccine.
- IPV, DPT, DT, Hepatitis B and TT vaccines are seriously damaged by being frozen at temperatures below 0°C. (Hepatitis B vaccine, for instance, freezes around -0.5°C.)
- Once potency has been lost through exposure to heat or cold *it cannot be regained* by returning the vaccine to the correct storage temperature.
- If potency is lost through heat exposure, vaccines do not change their appearance so it is not possible to see whether a vaccine in a vial has lost its potency without a complete laboratory test.

1.1 The vaccine vial monitor

Currently, all vials of oral polio vaccine (OPV) procured through the United Nations Children's Fund (UNICEF) come with a vaccine vial monitor (VVM). This heat-sensitive label gradually and irreversibly changes colour as the vaccine is exposed to heat. It warns the health worker when a vial of OPV should be discarded because the vaccine is likely to have been degraded by exposure to heat.

Figure 1: How to use the VVM

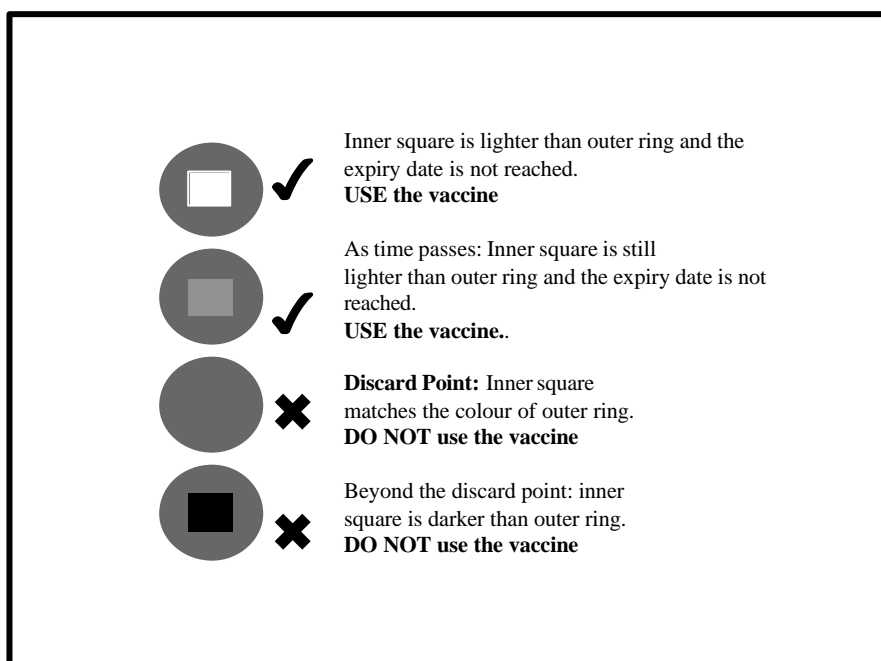

By the end of 2000, the VVM will be introduced for the five other EPI antigens, on all vaccine supplied through the UNICEF supplies division.

For more information on the use of the VVMs please refer to WHO/EPI publication:

- *Making use of vaccine vial monitors – flexible vaccine management for polio supplementary immunization activities* (WHO/V&B/00.14).

1.2 Vaccine storage volumes

The following table provides data for estimating the packed volume of vaccine required per fully immunized child. Adjusting any of the figures which have been assumed in this table requires that the table be recalculated according to the prescription at the head of each column.

Table 2: Packed volume per fully immunized child

Vaccine	No. doses per vial****	No. doses per fully immunized child	Packed volume per dose (cm ³)	Vaccine wastage (%)**	Wastage factor	Vaccine storage volume (cm ³)***	
						Multi-dose	Single-dose
	A	B	C	D	E	F	
Polio	10	4	1.5	40	1.6	9.6	9.6
Yellow Fever	10	1	3.0*	40	1.6	4.8	4.8
Measles	10	1	3.0*	40	1.6	4.8	4.8
BCG	20	1	1.5*	50	2.0	3.0	3
DPT	20	3	2.5	40	1.6	12.0	60.4
TT	20	2	2.5	40	1.6	8.0	40.3
Hepatitis B	10	3	3.0	40	1.6	12.0	60.4
Hib	1	3	18.3	5	1.1	0	60.4
Total net storage volume per fully immunized child (F.I.) cm ³						54.2	243.6
<p>* Volume without diluent</p> <p>** $E = 100/(100-D)$</p> <p>*** $F = B \times C \times E$</p> <p>**** 10 dose vial is for routine. A 20 dose vial is used for polio eradication supplementary immunization activities 1(cm³)</p>							

When single dose vials are used multiple by 4.5 for gross storage volumes in Table 3.

Although the total net storage capacity is estimated above as 54.2³ (using multi-dose vials), the following factors should be kept in mind:

- At higher levels of the cold chain, the vaccines are stored at different temperatures (see Table 1, p.3).
- The wastage rates (D) are only general estimates: they must be checked with local records (vials used versus doses correctly administered) to make correct national estimates. WHO/EPI has revised its policy on the use of opened vials of liquid vaccines in subsequent immunization sessions. See *WHO Multi-Dose Vial Policy* (WHO/V&B/00.09). The implementation of this policy and the availability of VVMs may result in substantial reduction of the vaccine wastage rates for DTP, OPV, TT,

DT and hepatitis B vaccines. Countries should monitor the vaccine wastage rates and adjust accordingly the quantities needed at each level.

- The packed volumes (C) are WHO maximum standards (EPI/CCIS/81.4 Rev.5). Locally made vaccines may occupy more space and this should be checked locally.
- Diluent for freeze-dried vaccines doubles the storage space necessary at health centre level (diluent does not need to be cooled except at the level at which it is to be used).

For example, based on the above table, approximate cold chain system requirements can be expressed as follows:

Table 3: Cold chain system requirements

Level	Temperature of storage	Population served	Type of equipment needed	Gross storage volume needed
National or regional stores (4 months stock)	0 to +8°C	Up to 5 M	Refrigerators	500 litres/M
	0 to +8°C	Over 5 M	Cold room	1.2 m ³ /M
	-15 to -20°C	Up to 25 M	Freezers	225 litres/M
	-15 to -20°C	Over 25 M	Cold rooms	0.7 m ³ /M
Transport to region (quarterly deliveries to ten regions simultaneously)	0 to +8°C	No limits	Cold boxes	47 litres/M
Transport to local stores (monthly deliveries to all stores simultaneously)	0 to +8°C	No limits	Cold boxes	16 litres per 100 000
Local stores, including health centres (6 weeks stock)	0 to +8°C	No limits	Refrigerator with icepack freezing	4.4 litres per 10 000

Legend: M = million population

The choices indicated above are provided as a guide to selection. They do not include important local factors that should be taken into consideration, such as the extra difficulty of installing cold rooms, as opposed to refrigerators or freezers. In all cases where the choice is not clear, the final decision must rest on local factors, such as the relative ease of importing, transporting, installing, operating and maintaining the equipment.

2. How to estimate the cost of equipping a cold chain

Table 4: Cold chain equipment costs

Item	Unit cost (US\$)	Qty each store	Spares per unit \$US	No. of stores	Total cost US\$	No. of years life	Cost per year US\$	Cost per immunized child
Vaccines [doses] (wastage multipliers)	(Cost per vial)							
BCG [20] infant (2.0)	0.98						34 300.00	0.098
DPT [20] infant (1.6)	1.31						110 040.00	0.314
Measles [10] infant (1.6)	1.06						59 360.00	0.170
Yellow fever [20] (1.6)	3.23						90 440.00	0.258
Polio [20] infant (1.6)	1.41						157 920.00	0.451
DT [20] school entry (1.1)	0.69						9 867.00	0.038
BCG [20] school entry (1.1)	0.98						14 014.00	0.054
Tetanus [20] mothers (1.6)	0.49						27 440.00	0.078
Hepatitis B [10] infant (1.6)	2.30						386 400.00	1.104
						Totals	889 781.00	2.566
Central level vaccine storage								
+4°C cold room, 30m.cu	15 400.00	1	5200.00	1	20 600.00	10	2 060.00	0.003
-20°C freezers, 12x300 litres	500	12	170.00	1	8 040.00	5	1 608.00	0.003
Icepack freezers	1 400.00	4	472.50	1	7 490.00	5	1 498.00	0.002
Thermorecorders	1000	2	340.00	1	2 680.00	5	536.00	0.001
Standby generator, 1x7kVA	6 860.00	1	2290.00	1	9 150.00	10	915.00	0.002
						Totals	6 617.00	0.011
Central vaccine distribution to regions								
Refrigerated vehicle	46 200.00	2	11 500.00	1	115 400.00	5	23 080.00	0.038
						Totals	23 080.00	0.038
Regional vaccine storage								
Ice-lined refrigerators, 204 litres	600.00	3	200.00	10	24 000.00	5	4 800.00	0.008
Ice-lined freezers, 200 litres	600.00	1	200.00	10	8 000.00	5	1 600.00	0.003
Dial thermometers	30.00	4	10.80	10	1 632.00	5	326.40	0.001
Icepack freezers	1400.00	1	472.00	10	18 720.00	5	3 744.00	0.006
						Totals	10 470.40	0.017
Regional vaccine distribution to districts								
Cold boxes, 20 litre	300.00	6	0.00	10	18 000.00	5	3 600.00	0.006
Icepacks, 0.6 litre	0.70	300	0.00	10	2 100.00	5	420.00	0.001
Transport, 1*0.5 ton van	13200.00	1	3000.00	10	162 000.00	5	32 400.00	0.053
						Totals	36 420.00	0.060
District vaccine storage								
Refrigerator/freezer	1200.00	1	360.00	100	156 000.00	5	31 200.00	0.051
Thermometer	36.00	1	0.00	100	3 600.00	5	720.00	0.001
Cold box, 25 litre	270.00	2	0.00	100	54 000.00	10	5 400.00	0.009
Icepacks, 0.6 litre	0.90	196	0.00	100	17 640.00	5	3 528.00	0.006
Vaccine carriers	12.00	4	0.00	100	4 800.00	10	480.00	0.001
Icepacks, 0.4 litre	0.30	32	0.00	100	960.00	5	192.00	0.001
						Totals	41 520.00	0.069

Item	Unit cost (US\$ ^a)	Qty each store	Spares per unit \$US	No. of stores	Total cost US\$	No. of years life	Cost per year US\$	Cost per immunized child
Health centre vaccine storage								
Refrigerator/icepack freezer	1200.00	1	360	500	780 000.00	5	156 000.00	0.256
Thermometer	1.50	1	0.27	500	885.00	5	177.00	0.001
Cold box, 15 litre	300.00	1	0	500	150 000.00	10	15 000.00	0.025
Icepacks, 0.4 litre	0.50	28	0	500	7 000.00	5	1 400.00	0.002
Totals:							172 577.00	0.284
Outreach immunization and vaccine collection								
Motor cycle 80cc	1 063.83	1	263.07	500	663 450.00	3	221 150.00	0.363
Vaccine carrier	12	2	0	500	12 000.00	5	2 400.00	0.004
Icepacks, 0.4 litre	0.3	16	0	500	2 400.00	5	480.00	0.001
Totals:							224 030.00	0.367
Option 1: autodisable immunization equipment at health centre level								
0.5 ml Autodestruct syringes with needle	0.085						349 350.00	0.998
Syringe disposal container, 5 l	1.00	69		500			34 500.00	0.099
Totals:							417 400.00	1.193
Option 2: sterilizable immunization equipment at health centre level								
0.05 ml ster.plastic syringes	0.19	30	0	500	2 850.00	1	2 850.00	0.005
0.5 ml ster.plastic syringes	0.19	70	0	500	6 650.00	1	6 650.00	0.011
5.0 ml mixing syringes	0.19	4	0	500	380.00	1	380.00	0.001
Forceps	5.1	2	0	500	5 100.00	5	1 020.00	0.002
Heater. kerosene	11.5	1	3.36	500	7 430.00	5	1 486.00	0.002
Steam sterilizer, 42 syringes	80	2	28.14	500	108 140.00	5	21 628.00	0.035
Needles, 26g 10mm	0.05	48	0	500	1 200.00	0.5	2 400.00	0.004
Needles, 22g 30mm	0.05	72	0	500	1 800.00	0.5	3 600.00	0.006
Needles, 18g 50mm	0.05	4	0	500	100.00	0.5	200.00	0.000
Timer clock	12	1	0	500	6 000.00	2	3 000.00	0.005
Hard water pad	26	1	0	500	13 000.00	2	6 500.00	0.011
TST control spots (per pack of 300)	5.31	2	0	500	5 310.00	1	5 310.00	0.009
Totals:							55 024.00	0.090
Grand totals, option 1 US\$ (including shipping)							2194452.31	3.597
Grand totals, option 2 US\$ (excluding shipping)							1 908 219.40	3.128

Explanation of Table 4

Approximate prices as of May 2000.

Assumptions: population 10 000 000; 100% coverage; 35/1 000 live birth rate; 26/1 000 school entry for DT and BCG boosters.

Number of children to be immunized per year:

$10\,000\,000 \times 35/1\,000 = 350\,000$ infants

$10\,000\,000 \times 26/1\,000 = 260\,000$ at school entry

Vaccine costs are calculated as follows:

Cost per year = no. of children x no. doses per child x wastage factor x price per vial/no. of doses per vial

For example:

Cost of BCG for infants = $350\,000 \times 1 \times 2 \times 1.40 / 20 = \text{US\$ } 49\,000.00$

Cost per child = cost per year / number of children = $49\,000 / 350\,000$
= US\$ 0.140

Other costs are calculated as follows:

Total cost = (cost per unit + cost of spares) x qty per store x no. of stores
(for spares, if the actual cost is not known, one third of the unit cost can be assumed)

Cost per year = total cost / no. of years life

Cost per immunized child = cost per year / no. of children

For example:

Cost of ice-lined refrigerators = $(600 + 200) \times 3 \times 10 = \text{US\$ } 24\,000.00$;

Cost per year = $24\,000.00 / 5 = \text{US\$ } 4\,800.00$;

Cost per child = $3\,900 / (350\,000 + 260\,000) = \text{US\$ } 0.008$

It is further assumed that only 20 syringes are sterilized per sterilization cycle and that each syringe disposal container is completely filled with 100 syringes.

3. Chlorofluorocarbons (CFC)

Environmental and human health concerns about the depletion of the ozone layer of the atmosphere, related to stratospheric Ozone Layer Depletion and Global Warming have led to a global effort to phase out the production and consumption of CFCs.

Until 1995, two major CFCs, R11 and R12, were commonly used as refrigerants in compression refrigeration circuits and as foaming agents for the insulation of refrigerators and insulated containers (cold boxes and vaccines carriers).

The international community has committed itself to the elimination of these refrigerants and foaming agents in an accord named the Montreal Protocol. The Montreal Protocol called for the cessation of CFC consumption (= production + imports - exports) as of 1 January 1996 in industrialized nations and from 1 January 2010 in developing nations.

This has had the following results:

R11 is no longer used as a foaming agent by any of the industrialized country manufacturers listed in the Product Information Sheets. It is now replaced by cyclopentane in European countries and by R141b in the USA (the use of R141b will eventually also be banned in 2030).

R12 is not used by a majority of the industrialized country manufacturers. It is commonly replaced with HFC 134a. Some manufacturers (primarily in Germany) also use R600 that is an isobutane. However, some countries (the United Kingdom and the United States) still allow the export of appliances using R12. This is why some of these appliances are still listed in the Product Information Sheets. WHO/EPI has decided not to accept the use of R600 or any other flammable gas for cold chain equipment (recommendations of the Technet subcommittee meeting on CFCs, October 1995 and 1998).

Developing country manufacturers continue to manufacture with CFCs but many of them have already submitted CFC-free samples for testing.

3.1 WHO Policy

WHO/EPI fully supports the recommendations of the Montreal Protocol.

- Countries are urged to stop purchasing equipment using CFCs.
- Manufacturers in the industrialized and developing countries are encouraged to switch to CFC-free production as soon as possible.
- CFC-free refrigeration training courses for cold chain technicians are held continuously.
- A co-operation agreement has been established in 1998 with UNEP DTIE's Ozone Action Programme – one of the Implementing Agencies of the Multilateral Fund for the Implementation of the Montreal Protocol – and proposals for jointly organised training workshops for cold chain technicians have been developed.

In the present edition of the Product Information Sheets, cold-chain equipment is listed in the following manner:

- If a manufacturer in an industrialized country produces two versions of one appliance, with and without CFCs, only the latter is listed.
- CFC-based models manufactured in industrialized or developing countries that allow the export of such systems. However, the information sheets for these appliances clearly indicate that they are using CFCs.
- CFC-free appliances are marked with the WHO/EPI recommended logo and the suffix "M" is added to the PIS code to indicate compliance with the Montreal Protocol.

WHO/EPI logo used to indicate that equipment is CFC-free



3.2 Recommendations to countries purchasing CFC-free equipment

When ordering new cold-chain equipment, programme managers should ensure that it is CFC free.

- It is recommended that the following points be considered:
 1. Has this CFC-free equipment been independently tested? (Information can be obtained from WHO or UNICEF.)
 - If no performance data are available then do not assume that they remain identical to the CFC model and request that independent tests be conducted.
 2. Does the performance of the CFC-free model meet the requirements of the programme (in terms of cold life, power consumption and holdover time)?

3. Are tools locally available for the repair of CFC-free equipment and have cold chain technicians been trained?
 - Tools can be ordered (see section E7 of this catalogue).
 - Training courses are ongoing.
 - Training modules for CFC equipment are currently being prepared and should go to press by the end of 2000.

4. When the equipment arrives in the country:
 - Check that the compressors are marked with a 100 mm blue disk that helps draw the attention of repair technicians.
 - Check that cold boxes and vaccine carriers are marked with the recommended WHO logo.
 - Keep an inventory of where the CFC-free appliances are installed.
 - To the extent possible, phase in the introduction of CFC-free equipment region by region or district by district so that they are concentrated in a limited number of health centres and ensure that repair technicians in these zones are trained and equipped with adequate tools.

More detailed information on the Montreal Protocol and ozone layer depletion, replacements for ozone-depleting substances and suppliers of alternative technologies can be obtained from:

UNEP DTIE OzonAction Programme
Tor Mirabeau
39-43, quai Andre Citroen
75739 Paris Cedex 15
France
Tel: +33 (1) 44 37 14 50
Fax: +33 (1) 44 37 14 74
Email: ozonaction@unep.fr
www.unepdtie.org/ozonaction.html

Section E1

Cold rooms for bulk storage of vaccines

1. Cold room buyers' guide

Recommendation: Selecting a cold room requires specialized knowledge on the product as well as on the suppliers. WHO/EPI strongly recommend purchasers to seek technical advice to assist in the decision-making process.

1.1 Step 1: invitation to tender

Approach at least three of the cold room suppliers (listed at the end of this chapter) in order to get a selection of competitive tenders. Each supplier should submit a design and draw up a tender on the basis of information you provide. Refer to the sample attachments below as a guide: Attachment 1 lists information which the supplier must provide with the tender; Attachment 2 outlines information which the buyer must submit.

It may also be helpful to make a rough sketch of any existing buildings near or at the proposed location and include it with the initial letter. The sketch should show approximate position and size of buildings, means of access, ceiling height/clearance, services available, proposed vaccine packing area, cold box storage area, etc.

As a further guide to estimating requirements, see the general information on "Vaccine storage volumes" (section 1.2, "General information").

*Sample***Attachment 1****Questionnaire for supplier**

1. What is the price (FOB and CIF)? What currency will be used?
2. What will be the period of delivery, from date of firm order?
How much time will be required for installation and commissioning after the site has been prepared?
3. What is the name and address of the supplier's local or nearest agent?
4. Will the supplier's own technicians or local contractors be responsible for installation, commissioning and service work?
5. What advance preparations is the client required to do in preparing the site for installation? For example:
 - What is the thickness, size and type of concrete base needed?
 - Is insulation required in the base?
 - What size access doors and passage ways are needed for the site?
 - What are the overall dimensions, ceiling clearances etc. needed for the site?
 - What is the space required for control panel and machinery; should this be located inside or outside?
6. What refrigerant is proposed for the system?
7. Are hermetic, semi-open or open type compressors proposed? (Note: Open type are preferred wherever practicable.)
8. What is the estimated total **starting current** per phase of the proposed system?
What is the estimated total **running current** per phase of the proposed system?
9. What is the estimated system-running time per 24 hours, based on stated conditions with four five-minute door openings? (Note: maximum is 75%.)
10. What is the estimated insulation heat leakage rate? (Note: the maximum is 0.22 W/m² per °C.)
11. What are the conditions of the proposed service contract? For example, frequency and number of maintenance visits, extent of spare parts and labour included for routine maintenance, conditions for emergency maintenance, currency of billing, etc.
12. What are the type and quantity of proposed spare parts included in the quotation?

Sample
Attachment 2
Outline specification for vaccine cold store
(Information to be provided by the buyer)

For central/regional/district* level vaccine storage, to be located in city/town/country*.

- To be constructed of sectional, prefabricated panels, and mounted on a flat, solid concrete base. The vaccine cold store must provide total, 24-hour, all-season reliability under all conditions for the stored materials.
- All refrigeration machinery must be provided with 100% standby capacity, with duplicate, independent controls, pipework, instrumentation and machinery, to provide against failure of the primary system. Automatic changeover and starting of the secondary system is to be provided, activated by thermostatic or electrical control*.
- Recommended spare parts to provide for 2 years normal operation, provision of a service contract covering routine and emergency maintenance requirements, and details of installation-commissioning and guarantee-period charges are each to be stated as separate items in the tender price quoted.

Technical requirements:

1. Vaccine storage volumes: refrigeration at +6°C m³; freezing at -20°C.... m³.
2. Mean ambient conditions** :
 normal maximum temperature°C at humidity %RH
 normal minimum temperature °C at humidity ... % RH
3. Cold store to be located inside/outside* an existing building, which has good/limited/nil* ventilation.
4. Local electrical supply (quote 3 phase supply conditions if available): (volts) v; (phase) ph; (cycles) hz. With reliability*: good (no interruptions)/limited (occasional failures)/ poor (frequent failures).
5. Standby diesel-electric generator with automatic/manual* starting to be provided, to carry full load of store, which will be located at an altitude of ... (*store elevation*) metres above/below* sea level.
6. Temperature monitoring of each cold room to be provided, with large scale external dial thermometers/7 day dual-pen chart recorders* for each room.
7. Cold store to be fitted with an audible alarm system to warn of high or low storage temperature (outside predetermined limits) and of power failure to cooling machinery.
8. Condensing unit(s) to comprise compressor, forced air condenser, oil separator, liquid receiver to carry full charge, filter/dryer with flare connections, service and isolating stop valves, high and low pressure dial gauges and oil level sight glass.

/continued

Sample Attachment 2 (continued):

9. Storage conditions to be maintained at 6°C \pm 2°C and -20°C \pm 5°C continuously, control by thermostat on each cold room, condensing unit(s) fitted with high and low pressure cutouts, time-operated electric defrost control and compressor motor overloads.
10. Cold room(s) to be fitted with locally made/manufacturer supplied* shelving approximately 600 mm wide x 600 mm pitch fitted on all walls; shelving to carry vaccine vials in packages.
11. Evaporators to be forced-draught, electric-defrost, ceiling-mounted units with fitted condensate drip tray and drain connection.
12. Door(s) to cold rooms to be lockable with 100% fail-safe provision for opening from inside.

* Delete as necessary to suit requirements and conditions.

** Annual day/night mean figures should be used where available, otherwise best estimates of highest and lowest temperatures and humidity at proposed location.

1.2 Step 2: evaluation of tenders

Once you receive the tender, together with complete information from the supplier, the next step is to evaluate the tenders with a view to making a final choice – not only on the basis of the lowest price but also on the availability of maintenance facilities, spare parts, etc.

Recent costing studies demonstrate that purchase and installation costs constitute a small proportion of the overall costs which accumulate over the working life of cold chain equipment. Buyers should therefore give serious consideration not only to the purchase and installation costs but also to the recurrent running costs for repairs, energy consumption and spare parts. This could mean that the selected equipment is more expensive initially but cheaper to run in the long term.

A tender should include the initial cost of the equipment, the installation costs, the expected running costs and the costs of a maintenance contract.

Narrowing the selection

However many tenders you receive from the initial invitation, it is fairly easy to eliminate the majority and arrive at two or three for final evaluation.

Reject tenders which:

- Do not conform to the general requirements of the *Outline specifications (Attachment 1)*, e.g. quotations which do not have duplicate standby systems, etc.

-
- Do not conform to the technical requirements of the *Outline specifications*, e.g. cold rooms which are too large or too small or have wrong electrical specifications, etc.
 - Do not supply the full information required in the *Questionnaire (Attachment 2)*, e.g. no service contract price, no delivery or installation period, etc.

Carefully study the following points:

- **Price:** The lowest bid does not mean the best value or the best system. Often Government agencies and donors will require a detailed justification if the lowest bid is not accepted. The final choice may depend on factors which more than justify a higher initial contract price, such as the availability of a local agent, the use of an open compressor system, or an installation with a substantially lower running time per 24 hours.
- **Quotations:** Treat quotations which are more than 10–15% lower than the majority with great caution. Study the small print conditions carefully as low prices often indicate that unacceptable economies have been made in the specification.
- **Timing:** Although in many cases installation will be required as soon as possible, other factors may dictate the ideal schedule, such as completion of the site, civil work or allocation and release of budgets. In this context, examine the supplier's response to question 3 (name and address of local agent) in the *Questionnaire*. This may also be a factor in the final ranking of suppliers.
- **Technical details:** Consider the details of the design once you have arranged the most likely suppliers in order of preference and discuss the following points with a technical representative from the potential suppliers:
 - Final position/orientation of store, means of access for personnel and vehicles, lighting, ventilation, packing, loading and despatch arrangements.
 - Position, access and security of the control panel, monitoring equipment, alarm units, servicing needs, etc.
 - Location and arrangement of standby generator, fuel tanks, exhaust outlets, silencing requirements, etc.
 - Details, capacity, control and operation of standby generator, anti-vibration mounts, voltage regulation, low oil pressure/high engine temperature shutdowns and/or alarms, recorder for hours run, mechanical and electrical supply/generator interlock, tools, spare parts, hand-starting handle and/or battery starter, etc.
 - Internal arrangement of the store, partitions separating each vaccine area, number and position of doors, lights. (Note: fluorescent lights must not be used in vaccine stores).

- Conditions for control and running of the system, automatic changeover on failure of primary cooling system and/or temperature rise, automatic generator start on power failure or interruptions (or hand-starting procedures), alarm unit settings, temperature settings, defrost periods.

Evaluate the remaining two or three tenders and compare the relative merits of each. The final choice will be the supplier who offers the most favourable conditions and satisfies your requirements on price, timing and technical details.

If you place your order through WHO Supply Services, include copies of the background correspondence with the supplier and some justification for the final choice.

1.3 Spare parts and tools

Spare parts for cold room

- evaporator/condenser fan motor
- capacitor
- contactor
- dual pressure switch
- thermostat
- drier
- control switch
- fuse, automatic
- timer
- high pressure switch

Additional service tools for cold/freezer rooms

- leak detector
- serviceman's kit in special case (R-134a or R404), including valves, hoses and manometers
- refrigerants cylinder (R-134a or R404), 12 kg
- compressor oil to be used with (R-134a or R404)

Spare parts for freezer room

- evaporator/condenser fan motor
- capacitor
- contactor
- auxiliary relay
- defrost timer
- dual pressure switch
- thermostat
- drier
- control switch
- fuse, automatic
- transformer
- high pressure switch

Common type of requested spare parts

- evaporator/condenser fan motor
 - contactor
 - dual pressure switch
 - thermostat
 - drier
 - control switch
 - timer
 - high pressure switch
-

1.4 Vaccine cold room suppliers

The following manufacturers and agents have experience in supplying cold rooms in tropical countries and are able to give quotations for installation and maintenance contracts. Inclusion in this list, however, does not imply recommendation by the World Health Organization.

The Americas

BMIL International, Inc.
61 Broadway (Suite 1900)
New York, N.Y. 10006
United States of America
Telephone: 1 (212) 898 96 99
Fax: 1 (212) 514 92 34
Email: bmil@bmil.com

Hussman Corporation
13770 Ramona Avenue
Chino, CA 91710
United States of America
Telephone: 1 (909) 590 49 10
Fax: 1 (909) 590 41 12
Email: marketing @hussmann.com

São Rafael Industria e Comercio Ltda.
Av. Celso Garcia 4285
São Paulo - Sp.
Brazil 03063-000
Telephone: 55 (11) 294 66 33
Fax: 55 (11) 293 22 52
Email: sr@saorafael.com.br

Africa

Ajax Refrigeration (PVT) Ltd
P O Box 1782
Harare
Zimbabwe
Telephone: 263 (4) 706616/790661
Fax: 263 (4) 727116
Telex: 26095 ajax zw

Africa (continued)

TUNDU Distributers
International Trading Division
4 th Floor Koblenz House
P.O. Box 4413, Harare
Zimbabwe
Telephone: 263 (4) 75 75 81-5
Fax: 263 (4) 75 75 86, 75 71 09, 75 6347
Email: tundu@harare.lafrica.com

Europe

Zhendre SA
122 Avenue des Pyrénées, B. P. 82
33883 Villenave D'Ornon, Cedex
France
Telephone: 33 (5) 56 87 71 20
Fax: 33 (5) 56 87 98 77
Email: zhendre@zhendre.com

Equipos Frigorificos Compactos S.A.
20180 Oyarzun (Gipuzkoa)
Spain
Telephone: 34 (943) 49 26 42
Fax: 34 (943) 49 03 05
Email: efc@adegi.es

Foster Refrigerator (UK) Ltd.
Oldmeadow Road, King's Lynn
Norfolk PE30 4JU
United Kingdom
Telephone: 44 (1553) 69 11 22
Fax: 44 (1553) 77 14 08

Europe (continued)

Huurre Group Oy
P O Box 127
FIN 33101 Tampere,
Finland
Telephone: 358 (3) 388 00
Fax: 358 (3) 388 0288
Email: info@huurre.com

UNITOR ASA
P.O.Box 300 Skoyen
N-0212 OSLO Norway
Telephone: 47 221 314 15
Fax: 47 221 345 00

South-East Asia

Blue Star Ltd.
Block 2-A, DLF Corporate Park
DLF Qutab Enclave, Phase – III
Gurgaon – 122 002
India
Telephone: 91 (124) 635 90 01
(20 lines: use 01-20 inclusive for last two digits)
(Use 91 instead of 124 if calling from Delhi)
Fax: 91 (124) 635 92 20/635 95 23
Email: neeraj.seth@bluestar.
sprintrpg.ems.vsnl.net.in

Western Pacific

SMI Co., Ltd.
Sanyo Electric Tokyo Building
1-10, Ueno 1-Chome, Taito-ku
Tokyo
Japan 110
Telephone: 81 (6) 69 92 40 15
Fax: 81 (6) 69 92 14 41/37 79
Email: SETB96133901@swan.
sanyo.co.jp

2. Standby generator buyers' guide

Most central cold chains need a standby generator unless the mains current is reliable. However, if power cuts are a chronic problem, review alternate solutions such as voltage stabilizers, ice-lined appliances or the use of equipment which runs on low voltages, kerosene or bottled gas. Don't take the decision to purchase a standby generator lightly as it involves an investment of several thousand dollars.

2.1 Estimating the size of the generator for an existing cold room

The size of the cold chain and the number of cold rooms, refrigerators and freezers determine the size of the standby generator. This information, plus data on temperature and altitude, is essential if the supplier is to make an accurate estimate of the size required.

Measure (by means of a clip ammeter) the starting and running currents of the cold room's electric motor and each of the refrigerators and freezers to be connected to the

generator. Note these values, expressed as "Amperes of starting current" and "Amperes of running current", in the outline specification for the supplier (*Attachment 1 to the letter*).

In addition, provide the supplier with figures for the ambient temperatures and the altitude at the site where the generator will be installed. The generator is "de-rated" as follows:

1% of its capacity for every 100 meters above sea level

1% for every 5.5° above 20°C.

Example:

Size required	14 KVA		
(determined by measuring starting and running currents)			
Altitude above sea level	+ 500 m	de-rating	5%
Ambient temperature	31°C	de-rating	2%
Total de-rating	7%		
Size of unit to be purchased	15 KVA	(14 + 7x14/100)	

Most cold chains operate on standby generators only during power cuts. If a standby generator needs to operate continuously on full power, rate it at 80% of the indicated output. Most manufacturers indicate outputs as continuous (normal) or standby (emergency boost).

2.2 Points to consider

Petrol or diesel: Most programmes opt for diesel. Diesel units tend to be more robust. Few manufacturers make petrol units large enough to support an extensive cold chain; Domestic petrol generators of the kind used in homes and shops are relatively cheap and easy to move around. However, they are not meant for continuous operation over a period of years; also, they are lightweight so can be stolen easily.

Manual versus electric (automatic) starting:

- Hand starting is far less expensive and more robust. However automatic starting may be needed when power cuts are frequent and cold chain staff are absent on nights or weekends.
- Hand starting is preferable for units up to 3 cylinders. For units up to 6 cylinders, it is preferable to have both options.
- When electric starting is selected, be sure to include a starting battery in the budget request since batteries are not normally supplied unless specified.
- Spring starters are an alternative that eliminates the need for a starting battery and charging equipment.

Type of cooling: Air-cooled units are easier to maintain than units with water cooling.

Mounting: A separately mounted fuel tank is often preferable to an engine-mounted tank, which is subject to vibrations.

Meter: A meter to record the number of hours run is a very useful feature. It helps the operator plan preventive maintenance.

Spare parts: The following should be included:

set of fan belts	1
water pump	1
fuel pump, with plunger and delivery valve	1
set of front and rear oil seals	1
gasket O/H set	1
set of piston rings	1
sets of decarbonizing joints	2
set of nozzles	1
set of inlet and exhaust valves, with guides	1
set of brushes	1
set of rubber parts	2
<i>(if used at places liable to distortion)</i>	
set of hose pipes	1
air/oil/fuel filters	5

Other recommended items: Mains isolator switch; fuse protection for all phases for the generator; a see-through fuel gauge (this is a cheap feature which enables the operator to see at a glance whether the unit needs refilling).

Soundproofing: Soundproofed enclosures are usually expensive and you may prefer to request a separate bid for them, without committing yourself. Locally made brick enclosures are often cheaper and, in the case of units installed outside, they also provide protection against the weather.

Fuel consumption: Ask for fuel consumption per hour. You can verify the accuracy of the supplier's figures if similar models are in use locally.

2.3 Invitation to tender

Sample letter to potential supplier :

Dear *(supplier)*,

re : Standby generator for vaccine cold store

Your company has been recommended to us as a possible supplier of standby power generators for use on vaccine-refrigerator and cold-store applications for health programmes in developing countries.

You are therefore invited to quote for the supply, installation and commissioning of a standby generator system for *(country)* according to the outline specification attached.

Tenders should be forwarded on or before *(date)*, addressed to *(buyer)* at *(address)*

Yours sincerely,

(buyer)

Enclosures:

Attachment 1: Outline specification for standby power generator

Attachment 2: Questionnaire for supplier

Below is a sample of Attachment 1 (information to be provided by the buyer):

Attachment 1
Outline specification for standby power generator

Please provide the following information.

General requirements

- Required for Central/Regional/District* Vaccine Store at (*city/town*), (*country*), to be commissioned and ready for use by (*date*);
- Recommended spare parts to provide for 2 years normal operation;
- Provision of a service contract covering routine and emergency maintenance requirements; and
- Details of installation commissioning and guarantee period charges are to be stated as separate items in the tender price quoted.

Technical requirements

1. Altitude at site: metres above/below* sea level.
2. Ambient conditions:
 - normal maximum temperature ... °C at humidity ... % RH
 - normal minimum temperature ... °C at humidity ... % RH
3. Local electrical supply at site :
 - (volts) ... v.; (phase) ... ph.; (cycles)... hz.
 - With reliability*:
 - Poor (frequent failures)/ limited (occasional failures)/ good (no interruptions)
4. To start and run ... cold room(s) having a measured phase starting current of ... amps, and a running current of ... amps. To start and run ... domestic refrigerators and freezers with the following start and run currents:

	Start Current	Run current
Refrigerator or Freezer, 1
Refrigerator or Freezer, 2
Refrigerator or Freezer, 3
5. To have a fuel tank capacity for 70 hours at full load.
6. To have controls for manual/and automatic starting* on failure of local supply.
7. Maximum voltage variation + 5%, no load to full load.*
8. Engine, air-cooled; diesel preferred.
9. Fitted with anti-vibration mountings.
10. To be located inside/outside* an existing building (but suitable provision to be made for a weather shield).*
11. Exhaust silencer to be provided.

* Delete as necessary to suit requirements and conditions.

Below is a sample of attachment 2:

Attachment 2
Questionnaire for supplier

1. What is the price (FOB and CIF)?
What currency will be used?
2. What will be the period of delivery to the site, from date of firm order?
How much time will be required for installation and commissioning after the site has been prepared?
3. What is the name and address of the supplier's local or nearest agent.
4. Will the supplier's own technicians or local contractors be responsible for installation, commissioning and service work?
5. What advance preparations is the client required to do in preparing the site for installation? For example:
 - What is the thickness, size and type of concrete base needed?
 - What size of access doors and passage ways are needed for the site?
 - What are the overall dimensions, ceiling clearances etc. needed for the site?
 - What is the space required for control panel and machinery; should this be located inside or outside? etc.
 - Is a weather shield proposed for the generator?
 - What is the access required for operation and servicing? etc.
6. What are the conditions of the proposed service contract? For example, frequency and number of maintenance visits, extent of spare parts and labour included for routine maintenance, conditions for emergency maintenance, currency of billing, etc.
7. What are the type and quantity of proposed spare parts included in the quotation?

2.4 Choosing among suppliers

There are many reasons for not purchasing from the lowest bidder. However, consider also other significant factors which reduce running costs, such as:

Fuel consumption: A model which has low fuel consumption may be cheaper to run over its whole working life than a model with a higher fuel consumption but a lower purchase price.

Local availability of technical expertise and spare parts: Visit the local office of the Food and Agricultural Organization (FAO), the fishery department or ice factory to see which models of heavy duty generators are most commonly used in your country. You can also check with them whether technicians are available locally to assist with maintenance if your programme doesn't have its own generator technicians.

Revolutions per minute (RPM): Generators with low RPM ratings, such as 1500 to 1800 RPM, are slow running and have longer working lives. (Models with RPMs of less than 1000 are rarely available.) Faster running models, with RPMs of 3000 to 3600, are found to require more maintenance, have a greater fuel consumption and wear at a higher rate. A cheap model with a high RPM may therefore not be a better choice than a more expensive model with a low RPM.

2.5 Suppliers of emergency generators

Inclusion in the following list does not imply any recommendation by the World Health Organization.

The Americas

Onan Corporation
1400 73 Avenue N.E.
Minneapolis, Minnesota 55432
United States of America
Telephone: 1 (612) 574 5671
Fax: 1 (612) 574 5282
Email: Paul.E.Edison@
Cummins.com

Europe

Lister Petter Ltd
Dursley
Gloucestershire
GL11 4HS
United Kingdom
Telephone: 44 (1453) 54 41 41
Fax: 44(1453) 54 67 32
Email: sales@lister-petter.co.uk

F.G. Wilson Engineering LTD
Old Glenarm Road
Larne, County Antrim, BT40 IEJ
Northern Ireland

United Kingdom

Telephone: 44 (28) 28 26 10 00
Fax: 44(28)28261111
Email: ptwilson@fgwilson.com

GENELEC SA

Z.I. Nord Aranas
62, Rue du Nizerand
69400 Villefranche s/Saone
France
Telephone: 33 (4) 74 62 65 02
Fax: 33 (4) 74 09 07 28
Email: genelec@genelec.tm.fr

Western Pacific

Yanmar Diesel Engine Co. Ltd.
Overseas Project Marketing Group
1-1-2, Yaesu
Chuo-ku, Tokyo 104-8486
Japan
Telephone: 81 (3) 32 75 49 43
Fax: 81 (3) 32 75 49 70
Email: admin@yanmar.co.jp

3. Voltage regulators for cold rooms

Recommendation: Where power supply is not stable WHO/EPI strongly recommend the use of voltage regulators to control voltage fluctuations.

Cold rooms in central stores are often damaged due to fluctuations in the power supply. This results in the premature need for repair and replacement of motors, compressors and other electrical components. You may, however, control voltage fluctuations by installing a voltage regulator on the power lines which supply the cold room equipment.

3.1 Types of regulator

The electronic servo regulator is composed of electronic elements, motors and transformers. The electronics monitor the input voltage. If the input voltage is not sufficient, a signal is sent to the motor which, in turn, regulates the output voltage on the transformer. The electronic and motor functions are sensitive and, without proper care, may fail. This regulator is one of the most accurate available and regulates a wide range of voltages. It is also, in most cases, the least expensive.

The solid state regulator has no moving parts such as the motor described above. It is therefore very reliable and efficient.

The pure transformer type also has no moving parts either. Its basic operation is by a combination of the magnetic flux and transformer concepts which together monitor the input voltage. By inducing magnetic fields, they regulate the output voltage when needed. The electronics on this type are generally very simple. It is the most reliable type available but is also the most expensive.

3.2 When to use a voltage regulator

Voltage regulators are strongly recommended in the following situations where, for example:

- A new vaccine cold room is being installed and experience in the area indicates that a problem already exists with the electricity supply at the site.
- It is likely that frequent damage to an existing vaccine cold room's motors, compressors, relays and other related electric equipment has been caused by an unstable supply of electricity.
- The area surrounding the vaccine cold room is under development and it is probable that the electricity supply will not develop at the same pace, resulting in an unstable, unreliable or fluctuating electricity supply. In such situations, first confirm whether the voltage supply is in fact unstable: measure the electricity supply at the site of the cold room at frequent intervals over a period of several days – for example, every hour from 6 am to 12 pm for a week. If the measurements show a fluctuation of more than $\pm 7\%$ from the standard voltage at any time, it is strongly recommended that a voltage regulator be installed.

3.3 Information for voltage regulator supplier

Submit the following information to the voltage regulator supplier when requesting information on the regulator most appropriate for your requirements:

- list of types of cold rooms on the site which need protection;
- details on any new rooms which are being planned for the near or distant future;
- size of the cold rooms (in KVA or Ampere);
- minimum and maximum measured voltage (input voltage range).

3.4 Suppliers of voltage regulators for cold rooms

Inclusion in the following list does not imply recommendation by the World Health Organization.

The Americas

Best Power
PO Box 280
Necedah, Wisconsin 54646
United States of America
Telephone: 1 (608) 565 7200
Fax: 1 (608) 565 2221
Email: contact@bestpower.com

Europe

Claude Lyons Ltd.
Brook Road
Waltham Cross, Herts EN8 7LR
United Kingdom
Telephone: 44 (1992) 768888
Fax: 44 (1992) 788000
Email: sales@claudelyons.co.uk

Europe (continued)

Advance Galatrek
Advance Park
Wrexham LL14 3YR
United Kingdom
Telephone: 44 (1978) 821000
Fax: 44 (1978) 810852
Email: sales@aelgroup.co.uk

Watford Control Instruments Ltd.
5 Godwin Road
Corby, Northants NN17 4DS
United Kingdom
Telephone: 44 (1536) 401345
Fax: 44 (1536) 401164
Email: watfordcontrol@cs.com

Section E2

Transport

1. Introduction

Vehicles are required in the Expanded Programme on Immunization for distribution of vaccine, supplies and equipment, maintenance visits, supervision and outreach immunization. This section covers the selection and/or purchase of three types of vehicle: general-purpose 4-wheel vehicles, refrigerated vehicles and motorcycles. Each vehicle should be selected according to the following considerations:

- suitability for the task;
- minimal running costs;
- availability of strong local agent support;
- vehicle model standardization in the fleet.

2. General purpose vehicles

2.1 Purchasing a vehicle

- New vehicles are manufactured to order. For standard vehicles the factory production time is 2–3 months, with a minimum EDA at the port of entry of 4 months after the manufacturer receives the order. For refrigerated vehicles an EDA of at least 6 months is standard.
- To benefit from the economies of large scale central purchasing, it is possible and advisable to purchase vehicles through UNICEF's Procurement Services Section in Copenhagen, Denmark, IAPSOs Motor Vehicle Procurement Section or WHO's Procurement Services in Geneva (see the preface for contact details) on the basis of United Nations standardized vehicle specifications.
- Deliveries direct from a stockist or dealer may shorten the normal factory delivery times but consider this alternative only as a last resort for the following reasons:
 - Vehicles delivered by stockists are built to general specifications and may not be sufficiently reinforced for heavy-duty use. This can give rise to problems in operation.
 - The specifications may not be fully compatible with vehicles normally imported into the country concerned. In such a case, the manufacturer's warranty does not apply.
 - The prices of vehicles bought from stockists are 20–25% higher than the prices of vehicles ordered directly from the factory.
 - Only a limited number of standard vehicles are available.
 - The time taken to receive bids and issue orders to several suppliers and then to coordinate shipments, possibly from different countries, greatly complicates the logistics.

2.2 Points to consider

Running costs/maintenance The running costs of any vehicle can exceed the initial cost after 12–18 months of operation and should be carefully calculated before the type and model are selected. The calculation must include the costs of maintenance, spare parts, fuel and oil. During the life of a vehicle, the costs of spare parts alone can exceed the purchase cost. Consider the possibility of importing sufficient spare parts for a maximum of one year at a time so that the ministry of health does not receive a vehicle that it cannot afford to run or maintain.

Spare parts Unless the ministry of health has kept comprehensive records of the consumption of spare parts which can be analysed, the best way to draw up a list of spare parts is with the manufacturer's local agent, even if a fee is charged. When managing spare parts pay particular attention to the need for frequent replacement of high-value parts such as tyres.

Vehicle sharing It is usually unreasonable and undesirable to have vehicles that can *only* be used for EPI activities. However, when a vehicle is shared between programmes it is important to specify which programmes have access to it and for what activities it will be used. Some programmes write a job specification or programme title clearly on the door of the vehicle.

Training for drivers The safety of drivers and passengers, as well as the working life of the vehicle, is greatly affected by the manner in which the vehicle is handled. A driver training course is available from the Vaccines and Biologicals Document Centre.¹ The modules include good driving techniques and essential maintenance. The certificate (also supplied by the Vaccines and Biologicals Document Centre), awarded to each driver who satisfactorily completes such training, is confirmation that the trainee has attained a certain level of competence. Local agents can also participate in driver training courses and may offer the services of technical staff to participate in repair and maintenance sessions, as well as specific training materials for the vehicles they have provided.

Training for mechanics Whether the vehicles are to be maintained by privately owned workshops or by ministry of health workshops, it is imperative that mechanics receive a thorough training. The cost of training the mechanics must be included in the budget. Some vehicle manufacturers provide training for mechanics and you should investigate the training opportunities before purchasing any vehicle.

Budget for workshop The long-term success of any transport policy depends largely on correct maintenance. An adequate operating budget for the vehicle maintenance workshops is essential. The budget must cover the initial, as well as the recurrent, costs of a maintenance workshop.

A guideline for monitoring vehicle use is available.²

¹ *Riders for health: manual for motorcycle instructors*. Geneva, World Health Organization, 1994. WHO/EPI/LHTM/94.1 (available on request from the Document Centre, Vaccines and Biologicals, World Health Organization, 1211 Geneva 27, Switzerland).

² *Monitoring vehicle use: a guide for transport officers*. Geneva, World Health Organization, 1994. WHO/EPI/LHIS/94.06 (available on request from the Document Centre, Vaccines and Biologicals, World Health Organization, 1211 Geneva 27, Switzerland).

3. Refrigerated vehicles

3.1 Points to consider

A number of operational problems arise from the use of refrigerated vehicles for the bulk transport of vaccines. Their use can therefore be justified only for very large programmes in countries with a population of more than 75 million. For smaller programmes, and even in a large country, transport using non-refrigerated vehicles and cold boxes is considered to be safer and more practical.

- A programme that depends on one or a small number of refrigerated vehicles may be seriously hampered if a vehicle breaks down. Make sure that you have alternative transport.
- Some cold boxes have enough cold life for the needs of most mobile or outreach facilities.
- Before you select a refrigerated vehicle for use in the EPI, consult local standardization policies and investigate local servicing facilities. In order to ensure that an appropriate unit is selected, include in the specifications for the supplier the ambient temperature of the region in which the vehicle will operate, and the temperature requirements of the refrigerated compartment. For cooling units that operate from a mains electricity supply while the vehicle is stationary, also give details of the mains voltage, number of cycles and the phase–pole connections.
- The general guidelines (given in section 2) on purchasing a general-purpose vehicle, apply equally to refrigerated vehicles and must be consulted when you are planning a purchase.

3.2 Types of cooling unit

Refrigerated vehicles usually have a cab for the driver, a chassis fitted with a separate insulated box-type body and a cooling unit. The following types of cooling unit are used:

Fitted cooling unit This is a cooling unit fitted to the engine of the vehicle. It has the following disadvantages:

- There is no cooling for the vaccines when the engine is not running;
- The cooling unit takes considerable power from the engine with the result that the vehicle is less powerful and is difficult to drive over rough or mountainous terrain.

Separate cooling unit This type of cooling unit is fitted to the truck body and has either a petrol or a diesel motor. It has the following advantage:

- A larger quantity of vaccines can be transported.

It has the following disadvantages:

- Prices vary greatly and are subject to special quotation.
- Specialist engineers are required for this type of unit so it is important to ensure that maintenance facilities are available for both the vehicle and the cooling unit.

Important

The fuel required for the cooling unit should be the same as the fuel required for the vehicle engine.

Mounted refrigerator A refrigerator mounted in the back of a standard vehicle offers little or no advantage over a normal cold box placed in that vehicle and it has the following disadvantages:

- The refrigerating and icepack-freezing capacity of the few models that fit into a standard vehicle are negligible once the vehicle is in motion.
- Unless the vehicle is fitted with a split-charge facility and two batteries, the refrigerator will run the vehicle battery flat in about 8 hours.
- A vehicle with a refrigerator mounted inside it becomes a special EPI vehicle that cannot be used for other primary health care activities.

Important

If no cold box with a sufficient cold life is available, a more reliable solution than to mount a refrigerator in a vehicle is to ensure the availability of freezing capacity along the way (install a freezer, or contact shops, restaurants, etc).

3.3 List of suppliers of refrigerated vehicles

Inclusion in the following list does not imply any recommendation by the World Health Organization.

Europe

Socamat

Chemin des Vignes

8090 Amiens, France

Telephone: 33 322 46 01 42

Fax: 33 322 46 19 79

Western Pacific

Isuzu Motors

Overseas Distribution Corporation

Toshin 24 Omori Building

6-8, Omori-Kita 1-chome

Otaku, Tokyo

143 Japan

Telephone: 81(3)3762 2516 /5471 1141

Fax: 81 (3) 3782 2537

Toyota Motor Corporation (Try contacting your local dealer before contacting TMC Japan.)

112-8701 4-18 Koraku 1-Chome

Bunkyo-Ku , Tokyo

Japan

Telephone: 81 (3) 3817 9761

Fax: 81 (3) 3817 9015

Email: naoko_ishikawa@mail.toyota.co.jp

4. Motorcycles

Along with other forms of individual transport, such as bicycles, horses and camels, the light motorcycle is widely used in the EPI, particularly in central America, South-East Asia and the Western Pacific. Although more expensive to run than a bicycle or a horse, motorcycles are faster and have a longer range.

For the equivalent of the purchase and running costs of one four-wheel drive vehicle, about eight light motorcycles can be purchased and run and will provide independent mobility to health workers or supervisors. The advantages that a motorcycle offers over a four-wheel vehicle include the following. They are:

- small enough to be stored inside a building for security;
- convenient to transport inside larger vehicles or on trains;
- suitable for riding on tracks and narrow paths;
- inexpensive to purchase and maintain;
- manoeuvrable on steep or difficult terrain.

A motorcycle does have some disadvantages, more fragile than a larger vehicle and the rider is exposed to the elements and is vulnerable.

4.1 Training for motorcycle riders

A training module has been developed and tested by WHO/EPI.¹ A set of guidelines on the introduction of fleets of light motorcycles in primary health care programmes is also available.²

4.2 Hints for the buyer

- It is essential that, during the warranty period (usually 6 months from the date of purchase), the agent assumes full responsibility for any defects in the new motorcycle(s) and deals directly with the manufacturer on your behalf. As the buyer, it is advisable not to undertake any assembly or major servicing yourself during this period.
- At the time of purchase, draw up an agreement with the local agents to establish their responsibility during the warranty period for assembly of the motorcycles, inspection and servicing. In addition, you should set out the requirements for spare parts and the agent's responsibilities regarding training of your workshop staff.
- Once the warranty period is over, the manufacturer is not liable for any defects that are found subsequently. It is therefore advisable to request the local agent to conduct a thorough inspection/service just before the warranty expires.

¹ *Riders for Health: Manual for Motorcycle Instructors*. Geneva, World Health Organization, 1994. WHO/EPI/LHTM/94.1 (available on request from the Document Centre, Vaccines and Biologicals, World Health Organization, 1211 Geneva 27, Switzerland).

² *Guidelines for introducing motorcycles into a primary health care programme*. Geneva, World Health Organization, 1994 WHO/EPI/LHIS/94.10 (available on request from the Document Centre, Vaccines and Biologicals, World Health Organization, 1211 Geneva 27, Switzerland).

4.3 Selecting the motorcycle

Consider the factors below in relation to your requirements.

- Do arrangements exist for inspection and maintenance of the motorcycles? If not, can they be set up?
- Will spare parts be provided through a local agent or by other means?
- Will protective helmets and/or special clothing be provided? By who?

Categories of motorcycle:

Category 1: Light moped for short distances, light loads and good roads.

Category 2: Light motorcycle for longer distances, light loads and good roads.

Category 3: Light motorcycle to carry two people, or one person with a heavier load; may be used off-road.

Category 4: Standard motorcycle for heavier loads; off-road travel and long distances on a road.

Category 5: Standard motorcycle for heavier loads and long distances on or off-road

Typical use for motorcycle

	Category 1	Category 2	Category 3	Category 4	Category 5
Engine size (cc)	<50 (moped)	50–90	90–110	110–150	150–250
Suitable for :					
Good roads, short distances	yes	yes	yes	yes	yes
Rough roads/terrain, short distances	no	no	yes	yes	yes
Good roads, long distances	no	no	yes	yes	yes
Rough roads/terrain, long distances	no	no	no	yes	yes
Acceptable loads :					
Number of persons	1	1	2	2	2
Long-range vaccine cold box	no	no	no	yes	yes
Short-range vaccine cold box	no	yes	yes	yes	yes
Vaccine carrier	yes	yes	yes	yes	yes

CODE

PIS E2/07

**Light on-road commuter type
motorcycle. Model Yamaha V80 (4GC2)**

COMPANY NAME AND ADDRESS

J. Gerber & Company (Japan) Ltd.
Sanshin Building No. 801
No.4-1, Yurakucho 1-chome
C.P.O. Box 360, Chiyoda-ku, Tokyo
Japan
Telephone: +81 (3) 3591 9251
Fax: +81 (3) 3591 0903
e-mail: info@jgerber.co.jp

SPECIFICATIONS

Engine :	79 cc, 2-stroke	Fuel:	regular gasoline and oil mixture (separate oil tank with autolube)**
Kerb weight:	82 kg	Fuel tank capacity:	5.3 litres
Total load*:	127 kg	Average fuel consumption:	1.4 litres/100 km at 50 kmh with 1 person
Maximum load of carrier:	5 kg	Ground clearance:	135 mm.
Number of seats:	2, including driver	Front suspension:	bottom link
Seat height:	740 mm	Rear suspension:	swing arm, with hydraulic dampers (2)
Transmission:	3 speed	Wheelbase	1170 mm
Starter:	primary kick	Front tyres:	2.25 – 17, 4PR
Voltage:	6 V	Rear tyres:	2.50 – 17, 4PR
Front and rear brakes:	drum		

SPARES NEEDED PER 10 UNITS/TWO YRS

	Part No.	Qty	Price/unit – FOB Shimizu
Manufactures recommended spare parts	-	-	JPY 91 910.00 (US\$ 851.41)

ACCESSORIES

Basic tool kit; Cargo carrier, rear; Leg shield; Turn indicators, front and rear; Rear view mirrors, 2

OPTIONS

Item	Price
Spare tyre, front	JPY 1 344.00 (US\$ 12.45)
Spare tyre, rear	JPY 3 033.00 (US\$ 28.10)
Spare tube, front	JPY 521.00 (US\$ 4.83)
Spare tube, rear	JPY 521.00 (US\$ 4.83)
Helmet, free size, (suitable for Medium or Large)	JPY 3 000.00 (US\$ 27.79)
Protective eye glasses	JPY 4 500.00 (US\$ 41.69)
Gloves	JPY 5 200.00 (US\$ 48.17)
Parts catalogue (English)	JPY 1 500.00 (US\$ 4.64)
Service manual (English/French)	JPY 4 000.00 (US\$ 37.05)
Pump (hand operated)	JPY 2 200.00 (US\$ 20.38)
Spare parts kit (1 machine for 1 year or 10,000km)	JPY 9 466.00 (US\$ 87.69)

COMMENTS

Meets specifications for IAPSO Category 2. Delivery time 6 weeks, ex factory.

2000 PRICE (FOB, Shimizu)

Shipping weight / vol (2 units) 211 kg / 1.108 m3
Quantity/price 1/JPY 114 840.00 (US\$ 1 063.83)

(Discount 50-79 units -1.5%, 80-99 units -2%, 100+ units -3.5%)

* Total load includes weight of rider, passenger, accessories and luggage. ** Automatic mixing of oil and gasoline.

CODE

PIS E2/08

Light on/off-road motorcycle Model Yamaha AG100 (5HS1)

COMPANY NAME AND ADDRESS

J. Gerber & Company (Japan) Ltd.
Sanshin Building No. 801
No.4-1, Yurakucho 1-chome
C.P.O. Box 360, Chiyoda-ku, Tokyo
Japan
Telephone: +81 (3) 3591 9251
Fax: +81 (3) 3591 0903
e-mail: info@jgerber.co.jp

SPECIFICATION

Engine :	97 cc, 2-stroke	Fuel:	Oil mixture (separate oil tank with autolube)**
Kerb weight:	99 kg	Fuel tank capacity:	11.0 litres
Total load*:	92 kg	Average fuel consumption:	1.82 litres/100 km at 30 kmh with 1 person
Maximum load of carrier:	Front carrier 2 kg; rear carrier 20 kg	Ground clearance:	235 mm.
Number of seats:	1 (single seater)	Front suspension:	telescopic forks
Seat height:	800 mm	Rear suspension:	swing arm with hydraulic dampers (2)
Transmission:	5 speed	Wheelbase	1315 mm
Starter:	kick start	Front tyres:	2.75 - 19, 4PR
Voltage:	6 V	Rear tyres:	3.50 - 18, 4PR
Front and rear brakes:	drum		

SPARES NEEDED PER 10 UNITS/TWO YRS

	Part No.	Qty	Price/unit – FOB Shimizu
Manufactures recommended spare parts	-	-	JPY 161 018 (US\$ 1 491.60)

ACCESSORIES

Basic tool kit; Cargo carrier, front and rear; Engine guard, skid plate under engine; Turn indicators, front and rear; Rear view mirrors, 2.

OPTIONS

Item	Price
Spare tyre, front	JPY 4 366.00 (US\$ 40.44)
Spare tyre, rear	JPY 8 022.00 (US\$ 74.31)
Spare tube, front	JPY 849.00 (US\$ 7.86)
Spare tube, rear	JPY 1 159.00 (US\$ 10.74)
Helmet, free size (suitable for M&L)	JPY 3 000.00 (US\$ 27.79)
Protective eye glasses	JPY 4 500.00 (US\$ 41.69)
Gloves	JPY 5 200.00 (US\$ 48.17)
Parts catalogue (English)	JPY 1 500.00 (US\$ 13.90)
Service manual (English)	JPY 4 000.00 (US\$ 37.05)
Pump, hand operated	JPY 2 200.00 (US\$ 20.38)
Spare parts kit (1 unit for 1 year or 10,000km)	JPY 21 199.00 (US\$ 196.38)

COMMENTS

Meets specifications for IAPSO Category 3. Delivery time 6 weeks, ex factory.

2000 PRICE (FOB, Shimizu)

Shipping weight / vol (2 units) 265 kg / 1.546 m³
Quantity/price 1/JPY 172 600.00 (US\$ 1 598.89)
(Discount 50-79 units: -1.5%; 80-99 units: -2.0 %; 100+ units: -3.5%)

* Total load includes weight of rider, passenger, accessories and luggage. ** Automatic mixing of oil and gasoline.

CODE

PIS E2/09

Medium-light on/off-road motorcycle Model Honda CT11OP/DK

COMPANY NAME AND ADDRESS

Honda Trading Corporation
Equipment and Machinery Division
Daiichi Tekko Building, 182 Marunouchi, Chiyoda-ku
Tokyo 163-1444, Japan
Telephone: 81 (3) 3215 9027
Fax: 81 (3) 3215 9080

SPECIFICATIONS

Engine :	105.1 cc, 4-stroke	Front and rear brakes:	leading/trailing drum
Dimensions:	189x78x106 cm	Fuel:	regular gasoline
Net weight:	89.5 kg	Fuel tank capacity:	4.8 litres
Total load (on carrier):	20 kg	Average fuel consumption:	1.67 litres/100 km.
Number of seats:	1 (single seater)	Ground clearance:	175 mm.
Seat height:	775 mm	Front suspension:	telescopic fork
Transmission:	4 speed	Rear suspension:	swing arm, hydraulic shock absorbers
Starter:	primary kick	Wheelbase	1220 mm
Voltage:	6 V	Front and rear tyres:	2.75-17 4PR, semi-knobbly

SPARES NEEDED PER 10 UNITS/TWO YRS	Part No.	Qty	Price/unit – FOB
Manufactures recommended spare parts	-	-	JPY 454 000.00 (US\$ 4 205.65)

ACCESSORIES

Basic tool kit; Cargo carrier, rear; Engine guard, skid plate under engine; Turn indicators, front and rear; Rear view mirrors, 2; Anti-theft device

OPTIONS

Item	Price
Helmet, medium or large size	JPY 6 800.00 (US\$ 62.99)
Parts catalogue	JPY 3 000.00 (US\$ 27.79)
Workshop repair manual	JPY 5 000.00 (US\$ 46.32)

COMMENTS

Meets specifications for IAPSO Category 3. Delivery time 12-16 weeks, ex factory.

Warranty varies from country to country and subject to final confirmation. Check warranty details carefully before placing order.

PRICE 2000 (FOB, Japan)

Shipping weight / vol (1 uni) 133 kg / 0.6 m³

Quantity/price 1/JPY 201800.00 (US\$ 1 869.38)

(Discount: 2 units JPY 187,600, 3-10 units JPY 176,100, 11-20 units JPY 173,600, 21-30 units JPY 172,900, 31-49 units JPY 172,500, >50 units JPY 168,700)

CODE

PIS E2/10

Light on-road motorcycle Model Suzuki A100 S

COMPANY NAME AND ADDRESS

K. Arano & Co. Ltd. (Suzuki)
Central P.O. Box 1701
Tokyo 100-91, Japan
Telephone: 81 (3) 3666 8151/3666 8344
Fax: 81 (3) 3666 2779/3668 2780
E-mail: k-arano@japan.email.ne.jp

SPECIFICATIONS

Engine :	98 cc, 2-stroke	Fuel:	Oil mixture (CCI lubrication)
Kerb weight:	83 kg	Fuel tank capacity:	10.5 litres
Total load*:	243 kg.	Average fuel consumption:	1.4 litres/1 00 km a
Number of seats:	2, including driver	Ground clearance:	140 mm.
Seat height:	780 mm	Front suspension:	telescopic, oil damped
Transmission:	4 speed	Rear suspension:	dual dampers
Starter:	primary kick	Wheelbase	1200 mm
Voltage:	6 V	Front and rear tyres:	2.50 - 18, on-road pattern
Front and rear brakes:	drum		

SPARES NEEDED PER 10 UNITS/TWO YRS	Part No.	Qty	Price/unit – FOB
Manufactures recommended spare parts	-	-	Contact Supplier directly

ACCESSORIES

Basic tool kit; Cargo carrier, rear headlight; Turn indicators, front and rear; Rear view mirrors, 2; horn; Owners manual in English.

OPTIONS

Item	Parts No.	Price
Spare tyre; front	55100-14012	JPY 1 938.00 (US\$ 17.95)
rear	65100-12111	JPY 2 013.00 (US\$ 18.65)
Spare tube	55200-14010	JPY 550.00 (US\$ 5.09)
Helmet, standard size	99000-9902Z-C10	JPY 4 750.00 (US\$ 44.00)

COMMENTS

Meets specifications for IAPSO Category 3 (90 - 110 cc)

Delivery time 13 weeks, ex factory, 4 weeks ex-stock. 6 months or 10,000 km warranty. Delivered in semi knocked down condition in Steel box.

2000 PRICES (FOB, Nagoya, Japan)

Shipping weight / vol (5 units) 502 kg / 0.95 m³

Quantity/price	1-49	1/JPY 122 000.00	(US\$ 1 130.15)
	50-99	1/JPY 118 340.00	(US\$ 1 096.25)
	100+	1/JPY 115 900.00	(US\$ 1 073.65)

* Total load includes weight of rider, passenger, accessories and luggage.

** For service manual in other languages, please contact the supplier or IAPSO.

CODE

PIS E2/11

Light on-road motorcycle Model Suzuki TF125W

COMPANY NAME AND ADDRESS

K. Arano & Co. Ltd. (Suzuki)
Central P.O. Box 1701
Tokyo 100-91
Japan
Telephone: 81 (3) 3666 8151/3666 8344
Fax: 81 (3) 3666 2779/3668 2780
E-mail: k-arano@japan.email.ne.jp

SPECIFICATIONS

Engine :	123 cc, 2-stroke	Average fuel consumption:	2.86 litre per 100km
Kerb weight:	102 kg	Ground clearance:	250 mm.
Total load*:	187 kg.	Front suspension:	telescopic fork
Number of seats:	1 (single seater)	Rear suspension:	adjustable fork, dual dampers
Seat height:	820 mm	Wheelbase	1335 mm
Transmission:	6 speed	Front tyres:	2.75 - 21, knobbly pattern
Starter:	primary kick	Rear tyres:	4.10 - 18, knobbly pattern
Voltage:	6 V		
Front and rear brakes:	drum		
Fuel:	Oil mixture (CCI lubrication)		
Fuel tank capacity:	13.0 litres		

SPARES NEEDED PER 10 UNITS/TWO YRS

	Part No.	Qty	Price/unit – FOB
Manufactures recommended spare parts	-	-	Contact Supplier directly

ACCESSORIES

Basic tool kit; Cargo carrier, rear; sump guard engine protection, Foot peg protection; Turn indicators, front and rear; Rear view mirrors, 2; brake light; headlight; horn; owners manual in English; speedometer.

Item	Parts No.	Price	
Engine protector	11910-48400	JPY 1 219.00	(US\$ 11.29)
Spare tyre, front	55100-29555	JPY 3 738.00	(US\$ 34.63)
Spare tyre, rear	65100-29560	JPY 5 438.00	(US\$ 50.38)
Spare tube, front	55200-16510	JPY 813.00	(US\$ 7.53)
Spare tube, rear	65200-44AA0	JPY 875.00	(US\$ 8.11)
Helmet, standard size	99000-9902Z-C10	JPY 4 750.00	(US\$ 44.00)

COMMENTS

Meets specifications for IAPSO Category 4. Delivery time 8 weeks, ex factory. 6 months warranty.
Delivery time 13 weeks, ex factory, 4 weeks ex-stock. 6 months or 10,000 km warranty. Delivered in semi knocked down condition in Steel box.

2000 PRICES (FOB, Nagoya, Japan)

Shipping weight / vol (2 units)	264 kg / 1.23 m ³		
Quantity/price	1-49	1/JPY 162 000.00	(US\$ 1 500.69)
	49-100	1/JPY 157 140.00	(US\$ 1 455.67)
	100+	1/JPY 135 900.00	(US\$ 1 258.92)

* Total load includes weight of rider, passenger, accessories and luggage

CODE

PIS E2/12

Basic on-road commuter type motorcycle: Yamaha YB100 (3XN1)

COMPANY NAME AND ADDRESS

J. Gerber & Company (Japan) Ltd.
 Sanshin Building No. 801
 No.4-1, Yurakucho 1-chome
 C.P.O. Box 360, Chiyoda-ku, Tokyo,
 Japan
Telephone: +81 (3) 3591 9251
Fax: +81 (3) 3591 0903
e-mail: info@jgerber.co.jp

SPECIFICATIONS

Engine :	97 cc, 2-stroke	Fuel:	Oil mixture (separate oil tank with autolube)
Kerb weight:	85 kg	Fuel tank capacity:	8.6 litres
Total load*:	187.5 kg	Average fuel consumption:	1.4 litres/1 00 km at 50 km/hr with 1 person
Maximum load of carrier:	5 kg	Ground clearance:	140 mm.
Number of seats:	2, including driver	Front suspension:	telescopic forks
Seat Height:	785 mm	Rear suspension:	dual dampers
Transmission:	4 speed	Wheelbase	1190 mm
Starter:	primary kick	Front and rear tyres:	2.5 - 18.4 PR
Voltage:	6 V		
Brakes, front and rear:	drum		

SPARES NEEDED PER 10 UNITS/TWO YRS	Part No.	Qty	Price/unit – FOB Shimizu
Manufactures recommended spare parts	-	-	JPY 137 539.00 (US\$ 1 274.10)

ACCESSORIES

Basic tool kit; Cargo carrier, rear; Turn indicators, front and rear; Rear view mirrors, 2.

OPTIONS

Item	Price
Spare tyre, front	JPY 2 184.00 (US\$ 20.23)
Spare tyre, rear	JPY 2 411.00 (US\$ 22.33)
Spare tube	JPY 765.00 (US\$ 7.09)
Helmet, free size (suitable for M&L)	JPY 3 000.00 (US\$ 27.79)
Protective eye glasses	JPY 4 500.00 (US\$ 41.69)
Gloves,	JPY 5 200.00 (US\$ 48.17)
Parts catalogue (English)	JPY 1 500.00 (US\$ 13.90)
Service manual (English or French)	JPY 4 000.00 (US\$ 37.05)
Pump (hand operated)	JPY 2 200.00 (US\$ 20.38)
Spare parts kit (1 unit for 1 year or 10,000km)	JPY 10 405.00 (US\$ 96.39)

COMMENTS

Meets specifications for IAPSO Category 1. Delivery time 6 weeks, ex factory.

2000 PRICE (FOB, Shimizu, Japan)

Shipping weight / vol (2 units) 227 kg / 1.108 m³

Quantity/price 1/JPY 132 210.00 (US\$ 1 224.73)

(Discount 50-79 units: -1.5%; 80-99 units: -2.0 %; 100+ units: -3.5%)

*Total load includes weight of rider, passenger, accessories and luggage. *** Normal rear cargo carrier is a standard accessory

CODE

PIS E2/13

Light-Medium on/off road motorcycle: Model Yamaha DT 125 (3TT4)

COMPANY NAME AND ADDRESS

J. Gerber & Company (Japan) Ltd.
Sanshin Building No. 801
No.4-1, Yurakucho 1-chome
C.P.O. Box 360, Chiyoda-ku, Tokyo,
Japan
Telephone: +81 (3) 3591 9251
Fax: +81 (3) 3591 0903
e-mail: info@jgerber.co.jp

SPECIFICATIONS

Engine :	123 cc, 2-stroke	Fuel:	Oil mixture (separate oil tank with autolube)
Kerb weight:	98 kg	Fuel tank capacity:	9.5 litres
Total load*:	213 kg	Average fuel consumption:	1.67 litres/100 km at 50 km/hr with 1 person
Maximum load of carrier:	2 kg	Ground clearance:	260 mm.
Number of seats:	2, including driver	Front suspension:	telescopic forks
Seat Height:	830 mm	Rear suspension:	monofork
Transmission:	6 speed	Wheelbase:	1340 mm
Starter:	primary kick	Front tyres:	2.75 – 21.4 PR
Voltage:	6 V	Rear tyres:	4.1 – 18.4 PR
Brakes, front and rear:	drum		

SPARES NEEDED PER 10 UNITS/TWO YRS	Part No.	Qty	Price/unit – FOB Shimizu
Manufactures recommended spare parts	-	-	JPY 157 491.00 (US\$ 1 458.93)

ACCESSORIES

Basic tool kit; Cargo carrier, rear; Turn indicators, front and rear; Rear view mirrors, 2.

OPTIONS

Item	Price
Spare tyre, front	JPY 5 773.00 (US\$ 53.48)
Spare tyre, rear	JPY 8 022.00 (US\$ 74.31)
Spare tube, front	JPY 983.00 (US\$ 9.11)
Spare tube, rear	JPY 1 159.00 (US\$ 10.51)
Helmet, free size (suitable for M&L)	JPY 3 000.00 (US\$ 27.79)
Protective eye glasses	JPY 4 500.00 (US\$ 41.69)
Gloves	JPY 5 200.00 (US\$ 48.17)
Parts catalogue (English)	JPY 1 500.00 (US\$ 13.90)
Service manual (English or French)	JPY 4 000.00 (US\$ 37.05)
Cargo carrier, rear, large ***	JPY 3 000.00 (US\$ 27.79)
Pump (hand operated)	JPY 2 200.00 (US\$ 20.38)
Spare parts kit (1 unit for 1 year or 10,000km)	JPY 17 781.00 (US\$ 164.72)

COMMENTS

Meets specifications for IAPSO Category 1. Delivery time 6 weeks, ex factory.

2000 PRICE (FOB, Shimizu, Japan)

Shipping weight / vol (2 units) 265 kg / 1.939 m³

Quantity/price 1/JPY 185 540.00 (US\$ 1 718.76)

(Discount 50-79 units: -1.5%; 80-99 units: -2.0 %; 100+ units: -3.5%)

* Total load includes weight of rider, passenger, accessories and luggage. *** Normal rear cargo carrier is a standard accessory

CODE

PIS E2/14

**Medium on/off road motorcycle:
Model Yamaha DT 175 (3TS4)**

COMPANY NAME AND ADDRESS

J. Gerber & Company (Japan) Ltd.
Sanshin Building No. 801
No.4-1, Yurakucho 1-chome
C.P.O. Box 360, Chiyoda-ku, Tokyo
Japan
Telephone: +81 (3) 3591 9251
Fax: +81 (3) 3591 0903
e-mail: info@jgerber.co.jp

SPECIFICATIONS

Engine :	171 cc, 2-stroke	Fuel:	Oil mixture (separate oil tank with autolube)
Kerb weight:	98 kg	Fuel tank capacity:	9.5 litres
Total load*:	213 kg	Average fuel consumption:	1.82 litres/100 km at 50 km/hr with 1 person
Maximum load of carrier:	2 kg	Ground clearance:	260 mm.
Number of seats:	2, including driver	Front suspension:	telescopic forks
Seat Height:	830 mm	Rear suspension:	monofork
Transmission:	6 speed	Wheelbase:	1340 mm
Starter:	primary kick	Front tyres:	2.75 – 21.4 PR
Voltage:	6 V	Rear tyres:	4.1 – 18.4 PR
Brakes, front and rear:	drum		

SPARES NEEDED PER 10 UNITS/TWO YRS	Part No.	Qty	Price/unit – FOB Shimizu
Manufactures recommended spare parts	-	-	JPY 157 235.00 (US\$ 1 456.55)

ACCESSORIES

Basic tool kit; Cargo carrier, rear; Turn indicators, front and rear; Rear view mirrors, 2.

OPTIONS

Item	Price	
Spare tyre, front	JPY 5 773.00	(US\$ 53.48)
Spare tyre, rear	JPY 8 022.00	(US\$ 74.31)
Spare tube, front	JPY 983.00	(US\$ 9.11)
Spare tube, rear	JPY 1 159.00	(US\$ 10.51)
Helmet, free size (suitable for M&L)	JPY 5 500.00	(US\$ 50.95)
Protective eye glasses	JPY 4 500.00	(US\$ 41.69)
Gloves	JPY 3 000.00	(US\$ 27.79)
Parts catalogue (English)	JPY 1 500.00	(US\$ 13.90)
Service manual (English or French)	JPY 4 000.00	(US\$ 37.05)
Pump (hand operated)	JPY 2 200.00	(US\$ 20.38)
Spare parts kit (1 unit for 1 year or 10,000km)	JPY 17 212.00	(US\$ 159.44)

COMMENTS

Meets specifications for IAPSO Category 1. Delivery time 6 weeks, ex factory.

2000 PRICE (FOB, Shimizu, Japan)

Shipping weight / vol (2 units) 265 kg / 2.111 m³

Quantity/price 1/JPY 195 840.00 (US\$ 1 814.17)
(Discount 50-79 units: -1.5%; 80-99 units: -2.0 %; 100+ units: -3.5%)

* Total load includes weight of rider, passenger, accessories and luggage. *** Normal rear cargo carrier is a standard accessor

CODE

PIS E2/15

**Medium on/off road motorcycle:
Model Yamaha AG 200 (3GXE)**

COMPANY NAME AND ADDRESS

J. Gerber & Company (Japan) Ltd.
Sanshin Building No. 801
No.4-1, Yurakucho 1-chome
C.P.O. Box 360, Chiyoda-ku, Tokyo
Japan
Telephone: +81 (3) 3591 9251
Fax: +81 (3) 3591 0903
e-mail: info@jgerber.co.jp

SPECIFICATIONS

Engine :	196.4 cc, 4-stroke	Fuel:	Oil mixture (separate oil tank with autolube)
Kerb weight:	112 kg	Fuel tank capacity:	10 litres
Total load*:	92 kg	Average fuel consumption:	2.44 litres/100 km at 50 km/hr with 1 person
Maximum load of carrier:	front 2 kg; rear 20 kg	Ground clearance:	245 mm.
Number of seats:	1, including driver	Front suspension:	telescopic forks
Seat Height:	820 mm	Rear suspension:	monoforks
Transmission:	5 speed	Wheelbase:	1345 mm
Starter:	primary kick	Front tyres:	3 - 19.4 PR
Voltage:	6 V	Rear tyres:	4.1 - 18.4 PR
Brakes, front and rear:	drum		

SPARES NEEDED PER 10 UNITS/TWO YRS	Part No.	Qty	Price/unit – FOB Shimizu
Manufactures recommended spare parts	-	-	JPY 202 076.00 (US\$ 1 871.94)

ACCESSORIES

Basic tool kit; Cargo carrier, front and rear; Turn indicators, front and rear; Rear view mirrors, 2.

OPTIONS

Item	Price	
Spare tyre, front	JPY 8 022.00	(US\$ 74.31)
Spare tyre, rear	JPY 8 988.00	(US\$ 83.26)
Spare tube, front	JPY 1 083.00	(US\$ 10.03)
Spare tube, rear	JPY 773.00	(US\$ 7.01)
Helmet,	JPY 5 500.00	(US\$ 50.95)
Protective eye glasses	JPY 4 500.00	(US\$ 41.69)
Gloves, Yamaha	JPY 5 200.00	(US\$ 48.17)
Parts catalogue (English)	JPY 1 500.00	(US\$ 13.90)
Service manual (English)	JPY 4 000.00	(US\$ 37.05)
Pump (hand operated)	JPY 2 200.00	(US\$ 20.38)

COMMENTS

Meets specifications for IAPSO Category 1. Delivery time 6 weeks, ex factory.

1998 PRICE (FOB, Japan)

Shipping weight / vol (2 units) 278 kg / 2.111 m³

Quantity/price 1/JPY 228 560.00 (US\$ 2 117.28)
(Discount 50-79 units: -1.5%; 80-99 units: -2.0 %; 100+ units: -3.5%)

* Total load includes weight of rider, passenger, accessories and luggag

Section E3

Refrigerators and freezers for storing vaccines and freezing icepacks

1. Choosing a refrigerator or freezer

1.1 Points to consider

When choosing a refrigerator or freezer, consider the following (see glossary for definition):

- 1) **Temperature Zones:** Base the purchase decision on one or a combination of the following considerations:

- (a) *A geographic distribution: use the equipment in geographic zones on basis of the prevailing climate. The average temperature during the hottest/coldest months should be taken as criteria for the determination of the zones. Hot zone equipment can be used in temperate zones.*
- (b) *A functional distribution: use temperate zone appliances in health facilities with sufficient ventilation or air conditioning, maintaining the temperature below +32°C and hot zone equipment at peripheral level where these conditions are not met and temperatures regularly exceed 32°C*

- 2) **Vaccine storage capacity:** How much vaccine must be stored:
 - (a) at 0-8°C; (b) at -20°C?

As a guide to calculating storage capacity, see the information on vaccine storage volumes (section 1.2, General information).

- 3) **Icepack freezing capacity:** How many icepacks should be frozen per 24 hours?

The freezers in these sheets are recommended when large quantities of frozen icepacks are needed and/or when the appliance is also used for vaccines. If the programme requires only icepack freezing, and capacity is not a major concern, any locally available freezer with low power consumption can be used.

- 4) **External temperatures:** Performance of the refrigerator/freezer at 32°C or 43°C:
 - (a) internal minimum and maximum temperatures; and
 - (b) high daytime and low night time temperatures.

For vaccine storage, select refrigerators that remain in the +0°C to +8°C range and freezers in the -15°C to -25°C range. Outside these ranges there is a serious risk of loss of potency for some of the vaccines.

- 5) **Power source:** Which power sources are available? (See flowchart under section 1.2.)

- (a) Electricity: what voltage; 50 or 60Hz; is supply continuous or not?
- (b) Kerosene or bottled gas?

Continuous refrigeration is required for vaccine storage. It is often difficult to ensure this in areas where power sources are intermittent or fuel is of poor quality. Ice-lined refrigerators can provide stable refrigeration even in areas of intermittent power. The longer the “holdover time” of the refrigerator, the better the security for the vaccine.

- 6) **Holdover time:** What holdover time is needed in case of power failure? How many hours will the vaccine remain below 10°C?

- 7) **Reliability:** Repair facilities and spare parts are available for which types?

Spare parts and repairs account for 40–50% of the whole-life cost of a refrigerator. Each of the models in this section is listed with essential spare parts, which will be needed within the first seven years' of the equipment's use. To avoid shortages later, purchase these spares at the time the equipment is purchased.

- 8) **Price:** Which refrigerator meets requirements 1 to 6 at the lowest cost? Remember to consider freight costs and freight times!

When placing your order for a refrigerator or a freezer, include a request for a thermometer; order a voltage stabilizer for electrical equipment if local conditions require one; and remember to specify the language for user's and service manuals.

- 9) **Training:** Are the users and those in charge of maintenance of the equipment properly trained?

The importance of users and technicians' training is often underestimated and therefore under budgeted. A cold chain with good equipment but insufficiently trained staff may seriously hamper an immunization programme. Users' handbooks for training on electric, kerosene, gas and solar refrigerators (WHO/EPI/LOG series) are available from the WHO Regional Offices or WHO V&B Document Centre, Geneva.

- 10) **CFCs:** All the models in the Product Information Sheets (PIS) that meet the conditions of the Montreal Protocol are marked with the WHP/EPI CFC-free logo (Section 3, General information). The suffix "M" is also added to the PIS code to indicate compliance with the Montreal Protocol.

1.2 Selecting an appropriate energy source

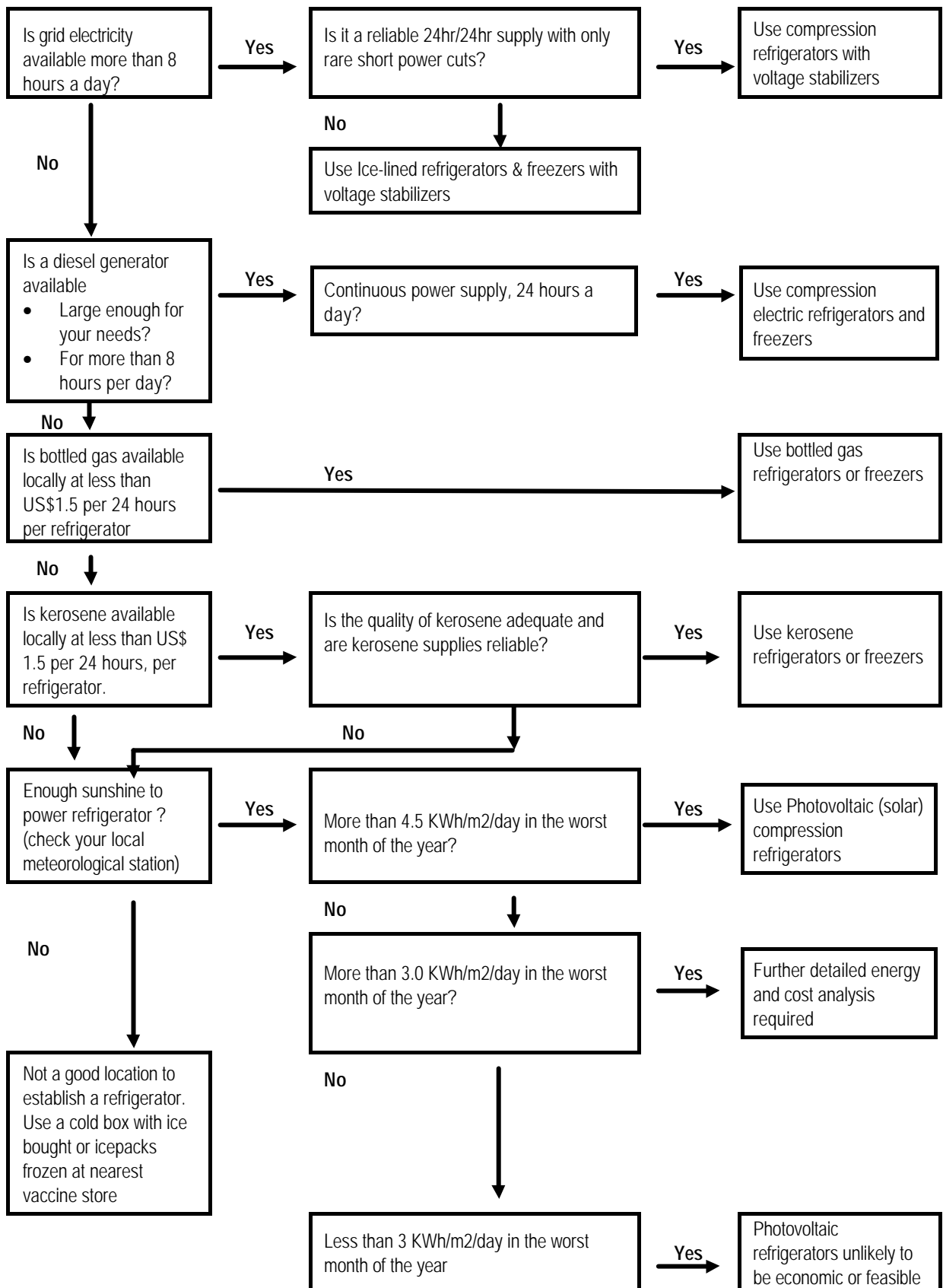

1.3 Which appliance to choose

Table 1 : Refrigerators - Power source options/vaccine storage capacity				
Vaccine (litres)	Power source option			
	Electric	Kerosene	Gas	Solar
≥100	E3/24-M; 27-M; 64-M			
50-99	E3/82-M; 84-M; 85-M	E3/85-M	E3/84-M	E3/79-M; 92-M
30-49	E3/62-M; 81-M			E3/ 76; 77-M
10-29	E3/21-M; 22-M; 30-M; 57-M; 75-M; 86-M; 87-M; 88-M; 89-M; 90-M; 91-M; 94-M	E3/22-M; 89-M; 91-M	E3/21-M; 86-M; 87-M; 88-M; 90-M	E3/31-M; 37-M; 65-M; 70-M; 83; 93-M
Table 2 : Freezers - Power source options/vaccine storage capacity				
Vaccine (litres)	Power source option			
	Electric	Kerosene	Gas	Solar
≥100	E3/27-M; 64-M; 97-M; 98-M; 99-M; 100-M	E3/95-M		
50-99	96-M			
10-49	101-M			
Table 3 : Icepack freezing capacity ¹⁾ at 32°C ambient temperature (per 24 hours) ²⁾				
Icepacks (kg)	Power source option			
	Electric	Kerosene	Gas	Solar
10-19	E3/62-M ³⁾ ; 97-M; 98-M			
5-9	E3/24-M; 95-M	E3/95-M		E3/37-M; 70-M; 79-M; 83
2-4	E3/30-M; 62-M ⁴⁾ ; 72-M; 73-M; 84-M; 85-M; 86-M; 88-M; 89-M; 90-M; 91-M; 94-M; 101-M	E3/73-M; 85-M; 89-M ; 91-M	E3/72-M; 84-M; 86-M; 88-M; 90-M	E3/76; 37-M; 76; 65-M; 92-M, 93-M
<2	E3/21-M	E3/21-M	E3/87-M	
Table 4 : Icepack freezing capacity ¹⁾ at 43°C ambient temperature (per 24 hours) ²⁾				
Icepacks (kg)	Power source option			
	Electric	Kerosene	Gas	Solar
10-19	E3/27-M; 62-M ³⁾ ; 80-M, E3/27-M; 96-M, 97-M; 98-M			
5-9	E3/24-M ⁴⁾ ; 99-M; 100-M			E3/70-M; 79-M
2-4	E3/75-M; 94-M; 101-M			E3/37-M; 65-M; 76; 77-M; 83; 92-M, 93-M
<2	E3/84-M; 85-M; 86-M; 95-M	E3/85-M; 95-M	E3/84-M; 86-M	

- 1) Figures present safe icepack freezing capacity with vaccines in the appliance. Figures in italic refer to icepack freezing capacity without vaccines of appliances of which the capacity with and without vaccines is not the same. These appliances appear therefore twice.
- 2) If icepack-freezing capacity in the relevant sheet is given for less than 24 hours it has been proportionally increased for these tables to obtain the capacity per 24 hours. As explained in the Glossary, this probably implies overestimation.
- 3) Measured with continuous energy supply.
- 4) Measured with intermittent energy supply.

2. Absorption refrigerators and freezers

WARNING! The improper use of kerosene refrigerators can lead to fire hazards and explosions. Such refrigerators are consequently potentially dangerous and can cause damage to persons and property. It is therefore essential that manufacturers' instructions be strictly followed. Before operating these refrigerators, users must receive adequate training.

Absorption refrigerators are driven by heat, either from an electric element, a gas flame or a kerosene wick burner. When operating with electricity or gas, the internal temperature is controlled automatically by a thermostat; on kerosene, the temperature is controlled manually by adjusting the wick of the kerosene burner up or down. Although the height of the gas flame is controlled by a thermostat device, the minimum “pilot” flame can still generate storage temperatures low enough to damage Tetanus Toxoid, DPT and Hepatitis B vaccines when the outside ambient temperature falls below +20°C.

Attention: Absorption refrigerators and icepack freezers do not perform as well as their compressor-driven equivalents. They require constant attention to ensure adequate performance for the vaccine cold chain.

Table 5: Comments on various fuel sources:

Fuel source	Temperature control	Routine maintenance	Other remarks
Electricity	Thermostatic control: good	Little required.	Requires frequent replacement of heating element when voltage varies widely.
LP gas	Thermostatic control: partial	Little required.	Pilot flame can cause excessive cooling in low ambient temperatures.
Kerosene	No thermostat. Wick must be manually adjusted day and night to control internal temperature when external temperatures vary or icepacks are being frozen.	Frequent cleaning and adjustment of wick and flue necessary.	Kerosene needs to be filtered before use.

Models that combine vaccine storage with icepack freezing within the same insulated chamber do not control temperatures or freeze icepacks as well as models that have separate icepack freezing and vaccine storage areas. Separate systems consisting of a refrigerator and a freezer, such as combining E3/22 and E3/73, use more fuel but can freeze the greatest quantities of icepacks and they *do* provide more reliable temperature control for vaccines.

3. Compression refrigerators and freezers

Compression refrigerators are driven by electricity and cannot operate on gas or kerosene. The compressor provides powerful cooling: approximately four times more than absorption refrigeration for the same input of electrical energy.

Wherever there is more than 8 hours of electricity per 24 hours, the **compression refrigerator** is preferred to the absorption refrigerator as its thermostat ensures correct internal temperatures in most conditions and less maintenance is required. Nevertheless, the selection of appropriate compression refrigerators for vaccine storage and icepack freezing remains very important.

Ice-lined refrigerators maintain temperatures below +8°C even with 16 hours electricity failure per 24 hours, day after day. Ice-lined refrigerators are strongly recommended at district, regional and central levels, since electricity supplies are rarely perfect and standby electricity supplies are not practical. An internal lining of water filled tubes or packs that surround the vaccine storage area provides the cooling. In order to freeze this water lining within a limited number of hours when the power is available (8 hours), the compressor has to operate extensively and, occasionally, the vaccine storage area in the bottom of the appliance falls below 0°C. DTP, Tetanus Toxoid and Hepatitis B vaccines should, therefore, NOT be stored within 150 mm of the base of these models. Some models have a mark inside the cabinet, which indicates areas potentially dangerous for the storage of these vaccines.

Icepack fast freezers have the highest rate of freezing, because of a special design. Icepack fast freezers are recommended wherever large quantities of icepacks are repeatedly needed in short time intervals. Icepack fast freezers come in two types; front loading upright fast freezers (such as E3/80-M) and chest freezers with fast freeze sections. Although the freezing rate is usually lower in a standard low-energy chest freezer, the capacity to store frozen icepacks is higher. Large quantities of frozen icepacks can, therefore, be accumulated in chest freezers for mass distribution of vaccines from central or regional stores.

Domestic freezers should never be used to store vaccines. On the other hand, when *only* icepack freezing capacity is required, the use of domestic freezers has some advantages: they are usually cheaper than the models presented in this catalogue; they can be bought locally; and spares and technical experience are locally available. This makes it possible to use other facilities (restaurants, shops, etc.) to provide ice for outreach, mobile sessions or mass immunization activities such as national immunization days (NIDs).

Domestic refrigerators: A number of countries, such as China, Colombia, Côte d'Ivoire, Egypt, Malaysia, Pakistan, Philippines and Thailand, purchase locally manufactured standard upright domestic refrigerators for storing EPI vaccines. There are a number of advantages to using domestic compression refrigerators: they are locally made and therefore readily available. No foreign currency is required for the purchase so they can be bought at subnational level using local funds; spare parts are available so repair and maintenance is usually easier than for imported equipment. They are usually front door models, making vaccine handling easier at peripheral level, contrary to the chest models in this catalogue.

Unfortunately there are also serious disadvantages to the use of domestic refrigerators: they are usually poorly insulated and are not designed to maintain the temperatures recommended for vaccine storage. They warm up quickly when electricity fails; temperatures rise above 8°C during icepack freezing and non-tropicalized models will not operate in high ambient temperatures (+43°C); temperatures often fall below freezing in areas close to the freezing compartment, especially in models without sufficient insulation of the refrigerating compartment. The doors are also poorly insulated and fitted with shelves as well as egg and butter compartments totally unsuitable for the proper conservation of vaccines. WHO/EPI has therefore supported the development of a simple modification kit to adapt domestic refrigerators to meet the requirements of vaccine storage.

Laboratory tests have been conducted in Colombia and Australia on a kit that can be installed in the field on a variety of different models. This kit is now listed in the PIS (E7/51). A manual is available from the V&B Document Centre, Geneva (WHO/EPI/LHIS/94.04) and another set of guidelines can be obtained from WPRO, Manila (*How to modify a domestic refrigerator for safer vaccine storage*, WHO/WPRO, September 1996.)

Standard, tropicalized domestic refrigerators may be acceptable under certain conditions, in areas where the climate is temperate and power supply is reliable. Work is now underway, as mentioned in the introduction of this edition, to develop new equipment performance standards that would apply to given areas rather than globally.

4. Solar refrigerator and freezer systems

Solar refrigeration systems are now widely used in many developing countries for the vaccine cold chain. They are sometimes the only alternative in areas where no reliable conventional energy supply is available. The flow chart under section 1.2 provides guidance on when to select solar refrigeration. In large-scale programmes, however, it is recommended that a pre-feasibility survey be conducted.

The standard specifications for solar refrigeration systems (below) should be sent to system suppliers with the invitation to tender and included among the requirements in the purchase contract:

**WHO/UNICEF standard performance specifications for solar
(photovoltaic) refrigerators & icepack freezers
(January 1998 revision)**

Type/features: Photovoltaic solar, compression cycle; combined or separate; CFC-free units: R134a refrigerant only. The acceptability of alternative refrigerant gases will however continue to be assessed. **Note:** R12 refrigerant is only acceptable within the geographic limitations and deadlines set by the Montreal Protocol on the ban of CFC gases.

Thermal insulation: Any gas complying with the geographic limitations and deadlines set by the Montreal Protocol on the ban of CFC gases can be used as thermal insulation foaming agent.

Photovoltaic system design: The system shall be sized to enable continuous operation of the refrigerator and freezer (loaded and including icepack freezing) during the periods of lowest insolation in the year. If other loads, such as lighting, are included in the system, they shall operate from a separate battery set, NOT from the battery set that supplies the refrigerator. In such a case, the charge regulator shall give priority to recharging the refrigerator battery set. The design of the system shall permit a minimum of five days continuous operation when the battery set is fully charged and the photovoltaic array is disconnected.

Temperature control: In continuous ambient temperatures of +32°C and +43°C the internal temperature of the refrigerator, when stabilized and fully loaded with the standard vaccine load, shall not exceed the range of 0°C to +8°C.

Safe freezing capacity: The recommended load of standard icepacks (type E5/IP.1) containing water at the ambient test temperature shall freeze in one freezing cycle in less than 24 hours and shall weigh at least 2 kg, without the material of the pack. During the test, the same thermostat setting shall be maintained and the above temperature control shall be demonstrated in continuous ambient temperatures of +32°C and +43°C and day/night cycling temperatures of +43°C/+15°C.

Freezer storage capacity: It is recommended that the freezer compartment be able to accommodate a minimum of 16 frozen icepacks (8 kg) (frozen gradually over several days).

Continued/

WHO/UNICEF standard performance specifications *(continued)*

Power consumption: Less than 0.7 KWh/24 hours for appliances with a gross volume of less than 50 litres, and less than 0.1 kWh per additional 10 litres gross volume, at 43°C with vaccine load, but without icepack freezing.

Photovoltaic array: Modules shall meet the latest applicable specifications laid down by the Jet Propulsion Laboratory (USA) or Joint Research Centre, Ispra, (Italy). Array structures shall be designed to withstand wind loads of +200 kg per square metre and shall be supplied with fixings for either ground or roof mounting. Protection against the effect of lightning should be provided to protect the battery charge regulator and other components.

Array-to-refrigerator cable: This cable shall be sized so that when the array is at its maximum operating temperature and maximum output, the voltage delivered is sufficient to charge the batteries at their maximum charge rate. The manufacturer shall provide recommendations for sizing the cable (as a function of the distance from array to control box).

Battery set: Batteries shall be capable of withstanding a minimum of 1000 cycles to 50% discharge. Maintenance intervals shall be limited to a maximum of once every six months. No dry cell batteries shall be used to power instruments or controls. The batteries shall be housed within a lockable ventilated cabinet with access for maintenance inspection in place. Batteries must meet the WHO/EPI design specifications (see WHO/EPI/LHIS/97.06). Supporting documentation on the batteries must be provided.

Batteries must be supplied dry/charged with acid in separate hermetic containers.

Battery charge regulator: Battery charge regulators must meet WHO/EPI design specifications. Supporting documentation must be provided. They must be precisely set to meet the charge and temperature requirements of the selected battery and they shall disconnect the load when the battery has reached a state of charge that can be repeated a minimum of 1000 cycles. Lightning surge protection shall be provided. The load shall be automatically reconnected when the system voltage recovers.

Markings and instrumentation: Compressors operating on R134a refrigerant should be marked with a blue disk painted or otherwise securely attached on their visible side. The disk should have a minimum diameter of 100 mm. An alarm (red LED) shall be installed to warn that power to the compressor has been disconnected by the regulator. An alarm shall also be fitted to warn the user when the battery is in a low state of charge. The advance warning to the user (voltage threshold if voltmeter used, or orange light if LED used) shall be clearly labelled "DO NOT FREEZE ICEPACKS" in an appropriate language.

An external reading thermometer shall be provided. A thermostat OR a defrost switch shall be accessible to the user without tools, but no other power switches shall be installed. Circuit breakers or fuses shall be installed in the positive line, near the battery, and the fuse-holder shall be in non-corrodible materials. Ten spare fuses shall be provided in a polyethylene bag fixed near any fuse box.

Continued/

WHO/UNICEF standard performance specifications *(continued)*

Essential spare parts: The type and number of spare parts which may be needed during the first five years of operation shall be assembled as a kit in appropriate quantities for central or regional storage in the country. As a minimum, there shall be:

Spare parts	Quantity per 10 systems :
Photovoltaic modules	1
Battery charge regulators	2
Battery sets	1
Array cables	1
Compressor or complete cooling unit, as recommended by the manufacturer	1
Spare compressor electronic control cards	3
Thermostat or temperature control cards	3
Condenser fans (if used)	2

Instructions/manuals: Manuals shall be provided with each refrigerator with clear descriptions for users and electrical technicians of: simple daily, weekly and monthly maintenance tasks; periodic preventive maintenance checks; diagnostic and repair procedures; temperature adjustments; installation procedures.

Corrosion resistance: Internal and external cabinet lid and frame protected against corrosion to DIN 8985.

Packing: Individual sea crating of the components of each system should be provided whether or not containers are used to transport the systems. No package shall be larger or heavier than can be handled manually in the country of use. Labels bearing handling instructions shall be highly visible and printed clearly. *NOTE: Acid must be provided for the batteries (see above under "Battery set").*

Warranty: Any component of the system that fails due to defective design materials or workmanship will be covered by a warranty for replacement. The minimum period of the warranty shall be 10 years for the solar array, 5 years for the batteries and 2 years for the other components.

4.1 Hints for buyers: use of solar energy technologies in the rural health sector

Over the past 10 years, the use of solar technologies in the rural health sector of developing countries has been, to a great extent, limited to the provision of vaccine refrigerators for the EPI cold chain.

WHO has conducted several in depth reviews of the programmes launched in Africa, the Americas and in South-East Asia. These have shown that:

- The technology is reliable and greatly improves the quality of the vaccine cold chain.
- The life cycle cost (over 10 years) remains relatively high in comparison with gas-powered refrigeration systems (when bottled gas is readily available and its supply is reliable).
- Maintenance and replacement of parts such as batteries and regulators, which becomes necessary after a period of five years on average, remains the major problem because these systems are often located in remote isolated areas and funds are rarely put aside for this purpose.

WHO has developed the following recommendations:

Solar technologies and, in particular, photovoltaics can meet, under certain conditions, the energy needs of rural health centres. They often provide the best quality of service although they are not always the most economic solution.

- 1) Programmes that focus exclusively on the implementation of vaccine solar refrigerators should be avoided.
- 2) Instead, integrated programmes should be elaborated to meet a wider range of the energy needs of the health facilities and take into account the long-term sustainability of the equipment.
 - A range of energy needs includes lighting for maternity rooms, for the in-patient rooms, for small surgery as well as DC power for small laboratory equipment such as centrifuges, microscopes, nebulizers, and for two-way radios, etc.
 - The nearby homes of the health workers should also be provided with small quantities of solar electricity for lighting, powering a radio/cassette player and/or TV set. It has been shown that this small addition to the overall power requirements of the health centres greatly benefits the quality of health services by improving the living and working environment of the health workers and increasing their motivation.
- 3) When equipping health facilities with solar energy technologies, the following steps should be followed:
 - The equipment should meet pre-established performance and design criteria. (Performance specifications for vaccine solar refrigeration systems are available from WHO/V&B Documentation Centre: *EPI Equipment Performance Specifications and Test Procedures*—WHO/EPI/LHIS/97.06.)
 - System suppliers must have the capacity to ensure long-term support of the equipment in the field. WHO has developed criteria for the qualification of systems suppliers (available from WHO/V&B Document Centre: *EPI Equipment Performance Specifications and Test Procedures*, section E3 RF4 WHO/EPI/LHIS/97.06).

-
- It is essential that the equipment be installed according to the highest standards of electrical equipment installation.
 - Users must be trained in the operation and daily maintenance of the systems. They should also be provided with clear instructions on who to inform in case of system failure.

Procedures should be established to ensure long-term maintenance of the systems, and replacement of parts such as batteries, regulators and lamps. The maintenance system relies on the presence in the country, and preferably in the area, of skilled technicians from the public or private sectors or from the community.

Price: The size of the solar array and the number of batteries required depend on the climate and the solar radiation where the system is to be installed. The price of the system varies, therefore, according to location:

- For areas with high solar radiation: 5.2 to 7.0 kWh/m²/day in the worst month, prices range from US\$ 3500 to US\$ 7500.
- For areas with lower levels of insolation: 3.5 to 5.2 kWh/m²/day in the worst month, prices range from US\$ 4000 to US\$ 7500.

Site: Give detailed information on the site of installation to the supplier to enable him to provide a refined system design. This will ensure that the system will neither run short of energy nor be unnecessarily oversized or expensive.

Batteries: When purchasing solar refrigeration systems, pay particular attention to the battery/charge regulator pair which, in the past, has proved to be the weakest part of the system. Request the system supplier to provide evidence that the charge regulator has been set up to the battery specifications, particularly when the supplier purchases these components from other manufacturers. WHO and UNICEF have established standard performance specifications for battery/regulator pairs in order to avoid the premature failures of batteries due to poor matching/poor performance *EPI Equipment Performance Specifications and Test Procedures* (WHO/EPI/LHIS/97.14) available from WHO/V&B Document Centre.

Batteries must be supplied dry/charged. Make sure that acid (electrolyte) is also supplied in a separate sealed container.

Low ambient temperatures – warning: Most single compressor solar refrigerators included in this document cannot freeze icepacks when the ambient temperature is permanently below 15 to 20°C. If you plan to use a solar refrigerator in a mountainous area or an area where the ambient temperature is permanently low, you should:

- (a) specify ambient temperature when making the initial invitation to bid
- (b) select a system with two independent compressors (e.g. E3/65 or E3/79), or a model that has shown good performance at low temperatures (e.g. E3/65).

Freezer compartments: It should be noted that the freezer compartments of the solar refrigerators listed here are not suitable for storage or freezing of vaccines. The freezer compartments should be used to freeze icepacks only.

4.2 Training

Solar refrigerators are technically reliable **but it is very important that the users as well as the installation and maintenance technicians receive thorough training.** The handbooks listed below are available for training purposes from WHO Regional Offices or from the V&B Document Centre, Geneva:

Logistic & cold chain for primary health care series :

Module 26: User's handbook for photovoltaic refrigerators
(WHO/EPI/LOG/86/26 Rev.1).

Technician handbooks for compression refrigerators:

Part H: Fault finding and repair of photovoltaic refrigerators/ freezers
Part E/Addendum: Task sheets on photovoltaic refrigerators
Part F/Addendum: Instructor's notes for photovoltaic refrigerators
Part I: Photovoltaic refrigerators – An installation handbook

International courses using the above solar training materials are held regularly and national training courses can also be organized for large-scale programmes. Contact WHO/EPI for materials and further information.

Solar photovoltaic refrigeration systems are offered by the supplier complete with a solar array to generate electricity, batteries to store the energy and regulators to control the system.

4.3 Criteria for suppliers

In order to meet the WHO/UNICEF criteria for supplying solar systems, a supplier must:

- Supply a coherent, well-sized system where the settings of all the components have been adjusted for optimum performance of the system.
- Have been responsible for the installation and support of at least 10 photovoltaic systems in a developing country, or countries, for at least two years (precise references, including donors, locations and contacts, must be provided).
- Have the capacity and financial resources to provide long-term support to the systems in the country of destination.
- Offer a refrigerator/icepack freezer which has passed independent testing following the WHO test protocol at a WHO-approved laboratory.
- Be willing to meet all the conditions laid out in the standard performance specifications that follow and the current terms and conditions of supply agreed between WHO and UNICEF.

4.4 List of qualified solar refrigerator system suppliers

The following manufacturers meet the above criteria for qualification as solar refrigeration system suppliers.

Europe

BP Solar Ltd.
PO Box 191, Chertsey Road
Sunbury-on-Thames
Middlesex TW16 7XA
Telephone: 44 (1932) 76 20 43
Fax: 44 (1932) 76 26 86
Email: garneri@bp.com

Dulas Ltd.
Dyfi Eco Parc
Machynlleth, Powys SY20 8AX,
United Kingdom
Telephone: 44 (1654) 70 50 00
Fax: 44 (1654) 70 30 00
Email: guywatson@gn.apc.org

Fortum AES Norway AS
Strandveien 50, N-1366 Lysaker
Norway
Telephone: 47 (67) 11 25 50
Fax: 47 (67) 11 25 45
Email: Fortum.aes@fortum.com

Boss Pro-Tec
Im Anwandel 12
72459 Albstadt
Germany
Telephone: 49 (7432) 983 80
Fax: 49 (7432) 17 19 70
Email: AxelBoss@swol.de

The Americas

Kyocera Solar Inc.
P O Box 457
4331 Pine Island Road
Matlacha, Florida 33993
United States of America
Telephone: 1 (941) 283 00 60
Fax: 1 (941) 283 47 88
Email: smccarney@kyocerasolar.com

Sun Frost
Box 1101
Arcata, California 95521-1101
United States of America
Telephone: 1 (707) 822 9095
Fax: 1 (707) 822 6213
Email: info@sunfrost.com

Asia-Pacific

BP Solar Australia Pty. Ltd.
4/114 Old Pittwater Road
P O Box 519 Brookvale, NSW 2100
Australia

Telephone: 61 (2) 94 54 51 11

Fax: 61 (2) 94 54 52 23

Email: gnanamf@az1.bp.com

TATA BP Solar India Ltd.
Plot Number 78, Electronic City
Hosur Road
Bangalore 561 229

India

Telephone: 91 (80) 852 10 16

Fax: 91(80) 852 09 72/01 16

5. Temperature zones

The biggest development for this issue of the PIS is in the area of temperature zones. For the first time refrigerators and freezers are classified by temperature zone.

Cold chain equipment recommended by WHO and UNICEF has to comply with a number of standards laid out in *the Equipment performance specifications and test procedures*, WHO/EPI/LHIS/97.09, volume 3. Evidence of compliance is obtained through a test in an independent testing institute.

These tests are mostly conducted at ambient temperatures of 32°C and 43°C. The rationale behind these standards and tests lies in the fact that up until recently most requirements for external cold chain supply originated from developing countries, generally located in hot temperature zones. In addition, one standard based on a single worst case scenario seemed to fit better in an overall approach of global standardization.

These standards therefore do not keep account with the real ambient temperatures the appliances are submitted to.

A number of developments have resulted in a change of this approach:

- The situation in the Newly Independent States and Central Asian Republics led to an increased external demand for appliances that can maintain correct storage temperatures even when ambient temperatures fall below 0°C, without vaccine being frozen. The existing appliances as well as the specifications and test procedures did not meet that need.
- There has been a tendency to let price considerations dominate considerations of quality. Setting the same standard globally, irrespective of the real conditions, was an invitation to some governments to introduce much cheaper domestic equipment, even though it had been demonstrated that these appliances do not maintain the correct storage temperatures.
- The global standard led to high quality equipment, being used at all locations, irrespective of the specific level of the cold chain. The option of having a stratified approach of high quality central and regional storage and sufficient but lesser quality peripheral storage did not exist.
- The switch to CFC free equipment in the context of the Montreal protocol has made compliance with the standards more difficult.
- The introduction of new vaccines, like hepatitis B, that should not be frozen and have higher freezing points, made it ever more urgent to deal with the problem of negative temperatures in refrigerators.
- Feedback from the field suggested that warnings on the appliances meant to prevent people from storing vaccine in areas with negative temperatures are not effective.

These developments led to the following changes in the equipment specifications and their presentation in the PIS:

- All refrigerators and freezers will be classified on the basis of their performance in specific temperature zones:
 - a hot zone that ranges from 0°C to +43°C
 - a temperate zone that ranges from 0°C to +32°C
 - a cold zone that ranges from -5°C to +32°C
- The temperature zones for which the appliances were tested and approved, will be clearly marked on the appliance (see figure 1).
- Negative temperatures in new refrigerators will no longer be accepted and manufacturers of existing appliances with areas where freezing occurs will have to show evidence of compliance with this rule by the end of 2000. Eventually all warnings should disappear.
- Manufacturers are invited to develop appliances that maintain correct storage conditions in negative ambient temperatures.

Figure 1: Temperature zone diagrams

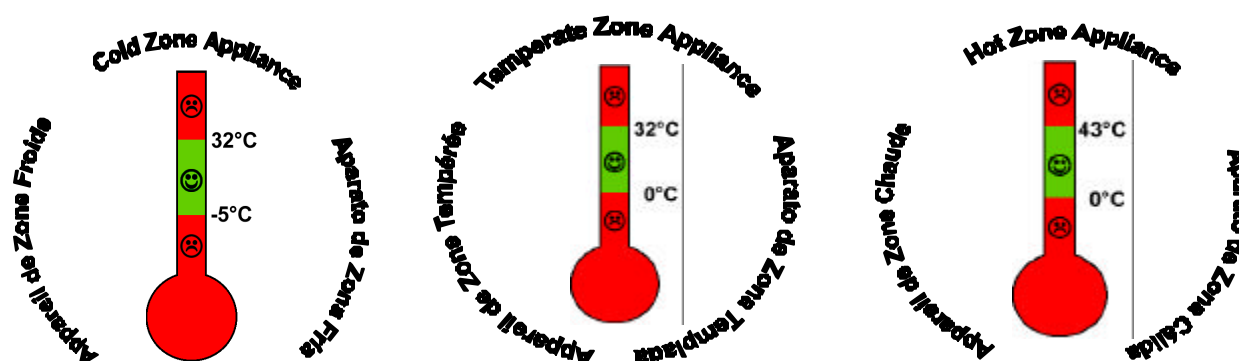

Temperature zones and equipment purchase

The choice of temperature zones specific equipment can be based on one or a combination of the following considerations:

- A geographic distribution: use the equipment in geographic zones on the basis of the prevailing climate. The average temperature during the hottest/coldest months should be taken as criteria for the determination of the zones. Hot zone equipment can be used in temperate zones.
- A functional distribution: use temperate zone appliances in health facilities with sufficient ventilation or air conditioning, maintaining the temperature below +32°C and hot zone equipment at peripheral level where these conditions are not met and temperatures regularly exceed 32°C.

Table of equipment based on the temperature zone in which they can be used:

Equipment by Temperature Zone

	Compression refrigerators and freezers	Absorbion refrigerators and freezers	Solar refrigerators
Cold Zone			
Temperate Zone		E3/21-M; E3/22-M E3/72-M; E3/73-M E3/87-M; E3/89-M E3/90-M; E3/91-M	
Hot Zone	E3/24-M; E3/30-M E3/31-M; E3/37-M E3/57-M; E3/62-M E3/64-M; E3/65-M E3/75-M; E3/80-M E3/81-M; E3/82-M E3/93-M; E3/94-M E3/96-M; E3/97-M E3/98-M	E3/84-M; E3/85-M E3/86-M; E3/88-M E3/95-M	E3/70-M; E3/76-M E3/77-M; E3/79-M E3/83-M; E3/92-M

Equipment by Temperature Zone and electricity supply

	No electricity	Intermittent electricity	Continuous electricity
Cold Zone			
Temperate Zone	E3/21-M; E3/22-M E3/72-M; E3/73-M E3/89-M; E3/90-M	E3/72-M; E3/73-M E3/89-M; E3/90-M;	
Hot Zone	E3/31-M; E3/37-M E3/65-M; E3/70-M E3/76; E3/77-M E3/79-M; E3/83 E3/84-M; E3/85-M E3/86-M; E3/87-M E3/88-M; E3/91-M E3/92-M; E3/93-M; E3/95-M	E3/24-M; E3/57-M E3/62-M; E3/64-M E3/75-M; E3/81-M E3/82-M; E3/85-M E3/87-M; E3/95-M	E3/30-M; E3/80-M E3/94-M; E3/96-M E3/97-M; E3/98-M E3/99-M; E3/100-M E3/101-M

6. Guide to refrigerator & freezers (by type)

Compression refrigerators and freezers

E3/24-M	Ice-lined refrigerator: TCW 1151/CF	Electrolux (Luxembourg)
E3/30-M	Refrigerator & icepack freezer: RCW 42AC/CF	Electrolux (Luxembourg)
E3/57-M	Ice-lined refrigerator: MK 144	Vestfrost A/S
E3/62-M	Ice-lined refrigerator & icepack freezer: TCW 1990/CF	Electrolux (Luxembourg)
E3/64-M	Ice-lined refrigerator or freezer: VC 139 F	LEC Refrigeration PLC
E3/75-M	Ice-lined refrigerator: MK 074	Vestfrost A/S
E3/80-M	Icepack freezer: TFW 800 (958.457510)	Electrolux (Luxembourg)
E3/81-M	Ice-lined refrigerator, compression type: Model MK 204	Vestfrost A/S
E3/82-M	Ice-lined refrigerator: compression type: Model MK 304	Vestfrost A/S
E3/94-M	Refrigerator & freezer: RCW 50 AC electric	Electrolux (Luxembourg)
E3/96-M	Vaccine/icepack freezer: MF114 (New Generation)	Vestfrost A/S
E3/97-M	Vaccine/icepack freezer: MF214 (New Generation)	Vestfrost A/S
E3/98-M	Vaccine/icepack freezer: : MF314 (New Generation)	Vestfrost A/S
E3/99-M	Vaccine/icepack freezer: FCW 300	Electrolux (Luxembourg)
3/100-M	Vaccine/icepack freezer: FCW 200	Electrolux (Luxembourg)

Absorption refrigerators and freezers

E3/21-M	Small refrigerator: RCW 42 EG/CF (P)	Electrolux (Luxembourg)
E3/22-M	Small refrigerator: RCW 42 EK/CF (P)	Electrolux (Luxembourg)
E3/72-M	Icepack freezer: FCW 20 EG/CF, electric and gas	Electrolux (Luxembourg)
E3/73-M	Icepack freezer: FCW 20 EK/CF, electric and kerosene	Electrolux (Luxembourg)
E3/74-M	Refrigerator and icepack freezer pair: RCW 42 & FCW 20EK/CF	Electrolux (Luxembourg)
E3/84-M	Refrigerator & freezer: V 170 GE gas and electric	Sibir International AB
E3/85-M	Refrigerator & freezer: V 170 KE kerosene and electric	Sibir International AB
E3/86-M	Refrigerator & freezer: V 110 GE gas and electric	Sibir International AB
E3/87-M	Refrigerator & freezer: V 110 KE kerosene and electric	Sibir International AB
E3/88-M	Refrigerator & freezer: RCW 50 GE/CF gas and electric	Electrolux (Luxembourg)
E3/89-M	Refrigerator & freezer: PR 245 K/E kerosene and electric	Zero Appliances
E3/90-M	Refrigerator & freezer: GR 245 G/E gas and electric	Zero Appliances
E3/95-M	Icepack freezer: PF 230 IP, electric and kerosene	Zero Appliances

Solar refrigerators

E3/31-M	Photovoltaic solar refrigerator & icepack freezer: RCW42DC/CF	Electrolux (Luxembourg)
E3/37-M	Photovoltaic solar refrigerator & icepack freezer: VR 50	BP Solar Ltd.
E3/65-M	Photovoltaic solar refrigerator and icepack freezer: NRC 30-10	Norcoast Refrigeration
E3/70-M	Photovoltaic solar refrigerator and icepack freezer: CFS49IS	NAPS Norway A/S
E3/76	Solar thermal vaccine refrigerator and icepack freezer	Comesse Soudure SA
E3/77-M	Solar photovoltaic refrigerator/icepack freezer: RFVB	Sun Frost
E3/79-M	Photovoltaic solar refrigerator & icepack freezer: Dulas VC150F	Dulas Engineering Ltd.
E3/83	Photovoltaic solar refrigerator and icepack freezer: TBP VR 50	TATA BP Solar
3/101-M	Photovoltaic solar refrigerator and icepack freezer: PVR 150	Solamatics

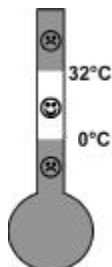

CODE PIS E3/21-M
Temperate zone appliance

Small refrigerator, absorption
RCW 42 EG/CF (Blue) (P) (920 51 60 01)

COMPANY NAME AND ADDRESS

Electrolux (Luxembourg) SARL
14, op der Hei
L-9809 Hosingen
Luxembourg
Telephone: 352 920 731
Fax: 352 920 731 300
E-mail: Pascal.Vannier@notes.electrolux.lu

SPECIFICATIONS

Vaccine storage capacity
Manufacturers gross volume
External dimensions, H x W x L

REFRIGERATOR	FREEZER	UNITS
10.5	0	litres
40	1.6	litres
50x54x82	—	cm.

PERFORMANCE AT

	32	43	32	43	degrees C°
Icepack freezing, with vaccine	—	—	0.4/8.5	++	kg/hrs.
Icepack freezing, without vaccine	—	—	++	++	kg/hrs.
Holdover time during power cut	++	++	++	++	hours
Power consumption: electricity	1.94	++	2.52	++	kWh/24 hrs
Power consumption: LP gas	++	++	—	—	kg/24 hrs.

ENERGY REQUIREMENTS

Energy sources: 220 V + 12V* + LPGas

RCW 42 EG/CF (C) can be supplied with 12 volt and 120 volt heating elements.

SPARES NEEDED PER 10 UNITS

	Part No.	Qty	Price/unit
Flame failure device	292.2006.01	3	XEU 6.04 (US\$ 5.49)
Electrical heater, 220 VAC	292.9491.41	2	XEU 5.73 (US\$ 5.21)
Gas thermostat	292.9363.00	2	XEU 24.28 (US\$ 22.07)
Door gasket or lid seal	292.8510.02	1	XEU 5.00 (US\$ 4.55)
Gas jet (butane, 30 mbar)	292.8787.06	2	XEU 1.41 (US\$ 1.28)
Thermocouple	292.8742.01	2	XEU 1.98 (US\$ 1.80)

COMMENTS AND ACCESSORIES

Reports: GET 50316-3300 (1995), Electrolux (1996); Meets WHO/UNICEF Standard: E3/RF.6.

Accessories: Locking door(s), external thermometer, gas jet 30 mbar. Appliance supplied either with rack for freezing 4 x 0.3 litre icepacks (Types: E5/06, 08, 10 & 12) or with trays for freezing ice-cubes. Removable partition between freezing and refrigerator compartments also provided. Note: the icepack freezing capacity of this type of appliance is limited. When large quantities of icepacks are needed this appliance must be associated with E3/72-M.

This item is colored blue, (formerly it was yellow). Specify the color required when ordering visible spare parts (hinges, etc.).

2000 PRICES (FOT Luxembourg)

Shipping volume / weight 0.33 m³ / 47 kg

Quantity/Price:	1-39:	XEU	988.00	(US\$	898.18)
	40-99:	XEU	864.00	(US\$	785.45)
	100+:	XEU	820.00	(US\$	745.45)
Export packaging per appliance		XEU	41.50	(US\$	37.73)

* If required without 12 V equipment, a deduction of XEU 16.00 (US\$ 14.54) per appliance

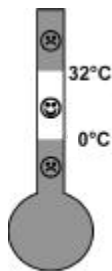

CODE PIS E3/22-M
Temperate zone appliance

**Small refrigerator, absorption
Model RCW 42 EK/CF (Blue) (P)**

COMPANY NAME AND ADDRESS

Electrolux (Luxembourg) SARL
14, op der Hei
L-9809 Hosingen
Luxembourg
Telephone: 352 920 731
Fax: 352 920 731 300
E-mail: Pascal.Vannier@notes.electrolux.lu

SPECIFICATIONS

Vaccine storage capacity
Manufacturers gross volume
External dimensions, H x W x L
Burner type

REFRIGERATOR	FREEZER	UNITS
18.2	—	litres
40	1.2	litres
72x54x82	—	cm
Cosmos 8	—	

PERFORMANCE AT

	32	43	32	43	degrees C°
Icepack freezing, with vaccine	—	—	(0.37/9)	++	kg/hrs.
Icepack freezing, without vaccine	—	—	++	++	kg/hrs.
Holdover time during power cut	(12.5)	++	—	—	hours
Power consumption: electricity	(1.6)	++	—	—	kWh/24 hrs
Power consumption: kerosene	(0.7)	++	—	—	lts/24 hrs.

ENERGY REQUIREMENTS

Energy sources: 220V + 12V* + Kerosene

The RCW 42 EK/CF can be supplied with 12 volt and 120 volt heating elements. (See revised modification kit, E7/44.)

SPARES NEEDED PER 10 UNITS	Part No.	Qty	Price
Lamp glass (metal)	293.0244.00	10	XEU 3.27 (US\$ 2.97)
Wick	292.8554.03	60	XEU 2.65 (US\$ 2.41)
Gasket	292.8510.02	5	XEU 5.00 (US\$ 4.55)
Flue brush	292.8557.00	2	XEU 3.47 (US\$ 3.15)
Electrical heater, 220VAC	292.9491.41	2	XEU 5.73 (US\$ 5.21)

COMMENTS AND ACCESSORIES

Reports: Electrolux (1996). Meets WHO/UNICEF Standard: E3/RF6.

Note: This refrigerator has a very limited freezing capacity. It should only be used for vaccine storage purposes.

When large quantities of icepacks are needed this appliance must be associated with E3/73-M.

Accessories: Locking door(s), external thermometer, lamp glass, flue brush, rack for freezing 4 x 0.3 litre icepacks. Can be supplied with trays for freezing icecubes instead. This item is colored blue, (formerly it was yellow). Specify the color required when ordering visible spare parts (hinges, etc.).

2000 PRICES (FOT Luxembourg)

Shipping volume/gross weight 0.33 m³ / 53.5 kg

Quantity/Price:	1-39:	XEU	1 169.00	(US\$	1 062.73)
	40-99:	XEU	1 111.00	(US\$	1 010.00)
	100+:	XEU	1 055.00	(US\$	959.09)
Export packaging per appliance		XEU	41.50	(US\$	37.73)

* If required without 12 V equipment, a deduction of XEU 16.00 (US\$ 14.54) per appliance.

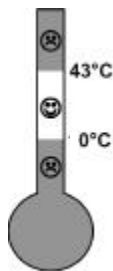

CODE **PIS E3/24-M**
Hot zone appliance

Icelined refrigerator, compression:
Model TCW 1152/CF (920 4251 07)

COMPANY NAME AND ADDRESS

Electrolux (Luxembourg) SARL
14, op der Hei
L-9809 Hosingen
Luxembourg
Telephone: 352 920 731
Fax: 352 920 731 300
E-mail: *Pascal.Vannier@notes.electrolux.lu*

SPECIFICATIONS

Vaccine storage capacity
Manufacturers gross volume
External dimensions, H x W x L

	REFRIGERATOR	FREEZER	UNITS
	(169)	—	litres
	(250)	—	litres
	85x66x105	—	cm.

PERFORMANCE AT

	32	43	32	43	degrees C°
Icepack freezing, with vaccine	++	++	—	—	kg/hrs.
Icepack freezing, without vaccine	++	++	—	1.2/14	kg/hrs.
Holdover time during power cut*	(42)	(42)	—	23.7	hours
Power consumption: electricity	(0.9)	(1.6)	—	4.09	kWh/24 hrs

ENERGY REQUIREMENTS

Energy sources: 220 VAC/50Hz. Min. number of hours electricity needed per 24 hours: 8 hours at 43°C°.
Note: Starts and operates on electricity supply from 165 to 255 volts. Can be supplied for 115 volts also.

SPARES NEEDED PER 10 UNITS

	Part No.	Qty	Price		
Starting device for compressor	291.2087.06	3	XEU	18.33	(US\$ 16.66)
Capacitor for compressor	291.2146.00	1	XEU	37.5	(US\$ 34.09)
Thermostat for refrigerator use	291.3700.00	3	XEU	9.86	(US\$ 8.96)
Thermostat for freezer use	291.2477.00	3	XEU	10.14	(US\$ 9.22)
Compressor, Danfoss FR10G/80	210.0272.00	1	XEU	243.06	(US\$ 220.96)

COMMENTS AND ACCESSORIES

Reports: Electrolux reg nr. 11844 (1994), CRL A12677 (1997); Meets WHO/UNICEF Standard E3/RF.3.

Warning: Temperatures near the base of this icelined refrigerator are liable to fall below zero so this area is not suitable for the storage of DPT, DT, TT and hepatitis B-vaccine.

Note: This appliance can also function as an icepack freezer (freezing capacity of 1.2 kg/14 hours with continuous energy supply), but is not suitable for freezing vaccines nor for storing frozen vaccines. The system can only function as a refrigerator or a freezer, but not both simultaneously.

Accessories: Locking door(s); external thermometer; baskets.

2000 PRICES (FOT Luxembourg)

Shipping volume/gross weight 0.85 m³ / 95.0 kg.

Quantity	Price/unit			
1-39	XEU	1 598.00	(US\$	1 452.73)
40-99	XEU	1 518.00	(US\$	1 380.00)
100+	XEU	1 442.00	(US\$	1 310.91)

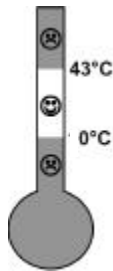

CODE PIS E3/30-M
Hot zone appliance

Refrigerator & icepack freezer, Electric, compression: RCW 42AC/CF(Blue)

COMPANY NAME AND ADDRESS

Electrolux (Luxembourg) SARL
14, op der Hei
L-9809 Hosingen
Luxembourg
Telephone: 352 920 731
Fax: 352 920 731 300
E-mail: Pascal.Vannier@notes.electrolux.lu

SPECIFICATIONS

Vaccine storage capacity
Manufacturers gross volume
External dimensions, H x W x L

REFRIGERATOR	FREEZER	UNITS
12*	—*	litres
36*	—*	litres
55x56x92*	—*	cm.

PERFORMANCE AT

	32	43	32	43	degrees C°
Icepack freezing, with vaccine	—	—	++	++	kg/hrs.
Icepack freezing, without vaccine	—	—	(2.1/24)	++	kg/hrs.
Holdover time during power cut	(+6)	(+4)	++	++	hours
Power consumption: electricity	++	++	++	++	kWh/24 hrs
Power consumption: kerosene	—	—	—	—	Its/24 hrs

ENERGY REQUIREMENTS

Energy sources: 12V or 24V. Request the version required.

SPARES NEEDED PER 10 UNITS

	Part No.	Qty	Price / unit	
Thermostat for refrigerator	292.2007.04	3	XEU 4.32	(US\$ 3.93)
Thermostat for freezer	292.2007.06	3	XEU 9.03	(US\$ 8.21)
Compressor for refrigerator	296.9701.03	1	XEU 205.08	(US\$ 186.44)

COMMENTS AND ACCESSORIES

Reports: Electrolux (1996); Meets WHO/UNICEF Standard: E3/RF.1

Accessories: Locking door(s). Supplied with rack for freezing 4 x 0.6 or 8 x 0.3 litre icepacks.

This item is colored blue, (formerly it was yellow). Specify the color required when ordering visible spare parts (hinges, etc.).

2000 PRICES (FOT Luxembourg)

Shipping volume/gross weight 0.39 m3 / 61 kg.

Quantity/Price**:	1-39:	XEU 1 269.00	(US\$ 1 153.64)
	40-99:	XEU 1 206.00	(US\$ 1 096.36)
	100+:	XEU 1 145.00	(US\$ 1 040.91)

* *Size figures apply for both as thermostat allows this equipment to be used either as a refrigerator/icepack freezer OR as a chest freezer. When used only as a freezer, can freeze 2.1 kg/24 hours at 32°C°*

** *Cost of export packing for sea freight not included in price (allow approximately XEU 49.00 (US\$ 44.54) per appliance.*

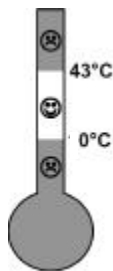

CODE PIS E3/31-M
Hot zone appliance

Photovoltaic solar refrigerator & icepack freezer, compression RCW 42DC/CF(Blue)

COMPANY NAME AND ADDRESS

Electrolux (Luxembourg) SARL
14, op der Hei
L-9809 Hosingen
Luxembourg
Telephone: 352 920 731
Fax: 352 920 731 300
E-mail: Pascal.Vannier@notes.electrolux.lu

SPECIFICATIONS

Vaccine storage capacity
Manufacturers gross volume
External dimensions, H x W x L

REFRIGERATOR	FREEZER	UNITS
14*	—*	litres
27*	—*	litres
50x55x92*	—*	cm.

PERFORMANCE AT

	32	43	32	43	degrees C°
Icepack freezing, with vaccine	—	—	(2.4/12)	(2.4/24)	kg/hrs.
Icepack freezing, without vaccine	—	—	++	++	kg/hrs.
Holdover time during power cut	(5.5)	(0.42)	++	++	hours
Electricity consumption:					
With icepack freezing	(0.48)	++	(0.6)	++	kWh/24 hrs
Without icepack freezing	++	(0.42)	—	—	kWh/24 hrs

ENERGY REQUIREMENTS

Energy sources: 12V or 24V. Request the version required.

SPARES NEEDED PER 10 UNITS

	Part No.	Qty	Price/unit		
Thermostat for electric refrigerator	292.2007.04	3	XEU	4.32	(US\$ 3.93)
Thermostat for freezer	292.2007.06	3	XEU	9.03	(US\$ 8.21)
Compressor for electric refrigerator	296.9702.04	1	XEU	205.8	(US\$ 187.09)

COMMENTS AND ACCESSORIES

Reports: Electrolux (1996); Meets WHO/UNICEF Standard: E3/RF.4.

If ambient temperature is permanently below +15 to +20°C, this appliance is not suitable for freezing icepacks. Freezer compartment should be used for icepacks only; it is not suitable for storage or freezing of vaccines.

Accessories: Locking door(s). Supplied with rack for freezing 8 x 0.3 or 4 x 0.6 litre icepacks.

This item is colored blue, (formerly it was yellow). Specify the color required when ordering visible spare parts (hinges, etc.).

2000 PRICES (FOT Luxembourg)

Shipping volume/gross weight 0.39 m³ / 61.5 kg.

Quantity/Price**:	1-39:	XEU	1 439.00	(US\$	1 308.18)
	40-99:	XEU	1 367.00	(US\$	1 242.73)
	100+:	XEU	1 299.00	(US\$	1 180.91)

IMPORTANT NOTE For Complete solar system (photovoltaic panel modules, batteries, battery charge regulators, array cables etc) consult section 4 of the introduction to this section and manufacturer.

* Size figures apply for both as thermostat allows this equipment to be used either as a refrigerator/icepack freezer OR as a chest freezer.

** Cost of export packing for sea freight not included in price (allow approximately XEU 49.00 (US\$ 44.54) per appliance.

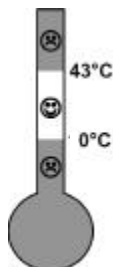

CODE PIS E3/37-M
Hot zone appliance

Photovoltaic solar refrigerator & icepack freezer: Model VR50F

COMPANY NAME AND ADDRESS

BP Solar Ltd.
PO Box 191, Chertsey Road
Sunbury-on-Thames, Middlesex TW16 7XA,
United Kingdom
Telephone: 44 (1932) 76 20 43
Fax: 44 (1932) 76 26 86
E-mail: garneri@bp.com

SPECIFICATIONS

Vaccine storage capacity
Manufacturers gross volume
External dimensions, H x W x L

	REFRIGERATOR	FREEZER	UNITS
Vaccine storage capacity	17.5	0	litres
Manufacturers gross volume	44	5	litres
External dimensions, H x W x L	63x65x86	—	cm.

PERFORMANCE AT

Icepack freezing, with vaccine
Icepack freezing, without vaccine
Holdover time during power cut
Electricity consumption:

	32	43	32	43	degrees C°
Icepack freezing, with vaccine	—	—	2.2/22	2.4/24	kg/hrs.
Icepack freezing, without vaccine	—	—	++	++	kg/hrs.
Holdover time during power cut	3.5	2.5	++	++	hours
Electricity consumption:					
With icepack freezing	--	--	--	1.7	kWh/24 hrs
Without icepack freezing	0.78	1.24	--	--	kWh/24 hrs

ENERGY REQUIREMENTS

Energy sources: 12VDC

SPARES NEEDED PER 10 UNITS

Spares kit for cabinet (as specified by WHO, see below)	Qty	Price
	1	GB£ 1 500 (US\$ 2 343.75)

COMMENTS AND ACCESSORIES

Reports: CRL A.12953 (1997); Meets WHO/UNICEF Standard: E3/RF.4, except for power consumption, which exceeds the standard of 0.7 kWh/24 hrs set by WHO/UNICEF for appliances of this size.

If ambient temperature is permanently below +15 to +20°C, this appliance is not suitable for freezing icepacks. Freezer compartment should be used for icepacks only; it is not suitable for storage or freezing of vaccines.

Cabinet is supplied with separate LED alarms indicating "Do not freeze icepacks" and "System off" as standard.

Cabinet features integral control unit calibrated for use with BP series batteries.

Accessories: Refrigerator spares kit for the cabinet for 10 units as specified by WHO/UNICEF comprises: 2 charge regulators; 1 array cable, 15 meter, 16mm²; 1 compressor; 3 spare compressor control units; 3 thermostats; 2 spare fan sets. Spare modules and battery sets also available.

2000 PRICES (FOB UK port)

<i>Shipping volume/gross weight:</i>	<i>cabinet only</i>	<i>0.6 m3 / 100 kg</i>
	<i>complete system</i>	<i>1.5 m3 / 390 kg</i>
	<i>spare parts kit</i>	<i>0.4 m3 / 160 kg</i>

Quantity/Price:	Cabinet	1/GB£	1 350.00	(US\$ 2 109.38)
	Complete solar system	1/GB£	2 600 to 2 900	(US\$ 4 056 to 4 524)

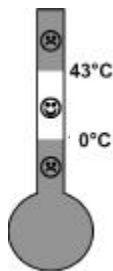

CODE PIS E3/57-M
Hot zone appliance

**Icelined refrigerator, compression type:
Model MK 144 (New Generation)**

COMPANY NAME AND ADDRESS

Vestfrost A/S
P. O. Box 2079
Spangsbjerg Mollevej 100
DK 6705 Esbjerg 0, Denmark
Telephone: 45 (79) 14 22 22
Fax: 45 (79) 14 23 55
E-mail: export@vestfrost.dk

SPECIFICATIONS

Vaccine storage capacity
Manufacturers gross volume
External dimensions, H x W x L

	REFRIGERATOR	FREEZER	UNITS
Vaccine storage capacity	45*	—	litres
Manufacturers gross volume	94**	—	litres
External dimensions, H x W x L	85x70x72	—	cm.

PERFORMANCE AT

	32	43	32	43	degrees C°
Icepack freezing, with vaccine	—	—	—	—	kg/hrs.
Icepack freezing, without vaccine	—	—	—	—	kg/hrs.
Holdover time during power cut***	45	15	—	—	hours
Power consumption: electricity	0.47	1.07	—	—	kWh/24 hrs
Thermostat setting: Continuous energy	6	6	—	—	

ENERGY REQUIREMENTS

Energy sources: 220 VAC/50 Hz
Available in various voltages: 115, 240 VAC, 50 or 60 Hz.
Minimum of 8 hours electricity needed per 24 hours at 43°C°
Voltage stabilizer recommended where power supply is intermittent.

SPARES NEEDED PER 10 UNITS

	Part No.	Qty	Price / unit
Compressor, Danfoss TL5G	03.6038602	1	XEU 62.72 (US\$ 57.02)
Starting device (Relay)	02.7038089	1	XEU 7.20 (US\$ 6.55)
Starting device (Capacitor)	6520004	1	XEU 12.48 (US\$ 11.35)
Electronic thermostat	02.6520154	1	XEU 14.65 (US\$ 13.32)
Thermometer	02.7020037-01	1	XEU 7.83 (US\$ 7.12)
Filter/drier type XH 9 (20 grs)	02.6538053	1	XEU 2.83 (US\$ 2.57)
Alu-cylinder with R134A (1000 grs)	04.9954073	1	XEU 28.80 (US\$ 26.18)
Basket for vaccine storage	02.3520402	1	XEU 4.85 (US\$ 4.41)

COMMENTS AND ACCESSORIES

Reports: Bureau Veritas TR99101(2000) . Meets WHO/UNICEF Standard:E3/RF.3.

Appliance equipped with HST compressor.

Accessories: external electronic temperature reading, 3 vaccine storage baskets, locking lid.

Warning: Temperatures near the evaporator of this icelined refrigerator are liable to fall to just above zero; as a precaution it is recommended not to store DPT, DT, TT and Hepatitis-B vaccine in this area.

2000 PRICES (FCA Esbjerg)

Shipping volume/gross weight 0.58 m3 / 70 kg.
Quantity/Price: XEU 425.00 (US\$ 386.36)

* Vaccine storage capacity measured with vaccines baskets in place

** Gross volume excludes the volume taken by the icelining

*** After intermittent power supply.

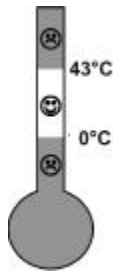
**CODE PIS E3/62-M****Hot zone appliance**

Icelined refrigerator & icepack freezer, compression type: Model TCW 1990

COMPANY NAME AND ADDRESS

Electrolux (Luxembourg) SARL

14, op der Hei

L-9809 Hosingen

Luxembourg

Telephone: 352 920 731

Fax: 352 920 731 300

E-mail: Pascal.Vannier@notes.electrolux.lu

SPECIFICATIONS

Vaccine storage capacity

Manufacturers gross volume

External dimensions, H x W x L

	REFRIGERATOR	FREEZER	UNITS
Vaccine storage capacity	37.5	—	litres
Manufacturers gross volume	66*	17*	litres
External dimensions, H x W x L	85x69.5x94	—	cm.

PERFORMANCE AT

Icepack freezing, with continuous energy

Icepack freezing, with intermittent energy —

Holdover time during power cut

Power consumption: continuous electricity 1.41

	32	43	32	43	degrees C°
Icepack freezing, with continuous energy	—	—	9.6/13	9.6/14	kg/hrs.
Icepack freezing, with intermittent energy —	—	(2.8/24)	0		kg/hrs.
Holdover time during power cut	38	17.2	++	++	hours
Power consumption: continuous electricity 1.41	1.92	++	++		kWh/24 hrs

ENERGY REQUIREMENTS

Energy sources: 220V 50Hz or 115VAC/60Hz

Minimum of 8 hours electricity needed per 24 hours at 43°C°

SPARES NEEDED PER 10 UNITS

	Part No	Qty	Price / unit		
Starting device	291.2087.05	3	XEU	13.33	(US\$ 12.12)
Capacitor for compressor	201.4555.66	1	XEU	47.08	(US\$ 42.80)
Thermostat for freezer use	291.2477.00	3	XEU	10.14	(US\$ 9.22)
Compressor, Danfoss FR8.5 G	210.0271.00	1	XEU	237.50	(US\$ 215.91)
Fan motor comp. room	291.2077.09	3	XEU	65.28	(US\$ 59.35)

COMMENTS AND ACCESSORIES

Reports: CRL A.10592 (1995/6); Electrolux (1996). Meets WHO/UNICEF Standard: E3/RF.3.

Appliance equipped with HST compressor which requires voltage stabilizer with minimum 2-minute delay.

Accessories: Basket; external thermometer; locking door(s)

Warning: Temperatures near the base of this icelined refrigerator are liable to fall below zero; this area is, therefore, not suitable for the storage of DPT, DT, TT and Hepatitis-B vaccine.

2000 PRICES (FOT Luxembourg)

Shipping volume/gross weight 0.79 m³ / 72.0 kg

Quantity/Price (including ocean packing):	1-39:	XEU	1 177.00	(US\$	1 070.00)
	40-99:	XEU	1 118.00	(US\$	1 016.36)
	100+:	XEU	1 062.00	(US\$	965.45)

* Gross volume excludes the volume taken by the icelining.

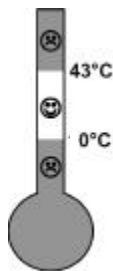

CODE PIS E3/64-M
Hot zone appliance

**Icelined refrigerator and icepack freezer,
compression type: Model VC 139 F**

COMPANY NAME AND ADDRESS

LEC Refrigeration PLC
Shripney Road
Bognor Regis, West Sussex P022 9NQ
United Kingdom
Telephone: 44 (1243) 86 31 61
Fax: 44 (1243) 82 54 40
E-mail: info@lec.co.uk

SPECIFICATIONS

Vaccine storage capacity
Manufacturers gross volume
External dimensions, H x W x L

	REFRIGERATOR	FREEZER	UNITS
Vaccine storage capacity	107.5	—	litres
Manufacturers gross volume	262	—	litres
External dimensions, H x W x L	96x66x129	—	cm.

PERFORMANCE AT

	32	43	32	43	degrees C°
Icepack freezing, with vaccines	—	—	++	++	kg/hrs.
Icepack freezing, without vaccines	—	—	++	++	kg/hrs.
Holdover time during power cut*	21	17	++	++	hours
Power consumption: continuous electricity 1.41	1.92	++	++		kWh/24 hrs

ENERGY REQUIREMENTS

Energy sources: 220V

Minimum of 8 hours electricity needed per 24 hours at 43°C°

SPARES NEEDED PER 10 UNITS	Part No	Qty	Price / unit
Starting device	117U6005	3	Prices on request
Capacitor for compressor	117U5017	1	
Thermostat for freezer	E1260	3	
Thermostat for refrigerator	E1116	3	
Compressor	104G8520	1	
Fan motor comp. room	N1116	1	

COMMENTS AND ACCESSORIES

Reports: UNIVALLE E3/2089-04-97(1997) and CRL A.12677 (1997).

Meets WHO/UNICEF Standard: E3/RF.3.

Appliance is HST and does not require time delay.

Warning: Temperatures near the base of this icelined refrigerator are liable to fall below zero; this area is, therefore, not suitable for the storage of DPT, DT, TT and Hepatitis-B vaccine.

This appliance complies also with WHO/UNICEF standard E3/FR.1. for vaccine/icepack freezers. **It is suitable for freezing vaccines and icepacks (2.4 kg / 16 hours) during continuous energy supply, but freezing performance during intermittent energy supply has not been tested.**

2000 PRICES (FOB)

Shipping volume/gross weight

1.45 m³ / 208 kg

Quantity/Price :

1-10

1/GB£

996 (US\$ 1 556.25)

11 +

Price on application

* After intermittent power supply

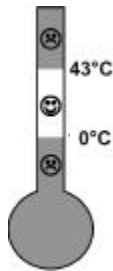

CODE PIS E3/65-M
Hot zone appliance

Photovoltaic solar refrigerator and icepack freezer: Model NRC 30-10

COMPANY NAME AND ADDRESS

Norcoast Refrigeration Co.
50 Grigor Street
Caloundra, QLD 4551
Australia
Telephone: 617 9491 1849
Fax: 617 5491 7627

SPECIFICATIONS

Vaccine storage capacity
Manufacturers gross volume
External dimensions, H x W x L

REFRIGERATOR	FREEZER	UNITS
15.5	—	litres
28.2	12.2	litres
510x590x970++		cm

PERFORMANCE AT

Icepack freezing, with vaccine
Icepack freezing, without vaccine
Holdover time during power cut

32	43	32	43	degrees C°
—	—	2.1/18	2.1/15	kg/hrs.
—	—	++	++	kg/hrs.
4.1	2.1	—	—	hours

Electricity consumption:

With icepack freezing	—	—	0.45*	0.85*	kWh/24 hrs
Without icepack freezing	0.44*	0.82*	—	—	kWh/24 hrs

ENERGY REQUIREMENTS

Energy sources: 12VDC

SPARES NEEDED PER 10 UNITS

	Part No.	Qty	Price / unit
Compressor, Danfoss	101 Z1200	1	US\$ 220.00
Controller, Danfoss	101 Z0200	1	US\$ 220.00
Lid seal	LS 30/10	1	US\$ 25.00

COMMENTS AND ACCESSORIES

Reports: AIT, 28/11/96.

Meets WHO/UNICEF Standard: E3/RF.4.

Suitable for freezing icepacks at low ambient temperatures.

Freezer compartment should be used for icepacks only; it is not suitable for storage or freezing of vaccines. It can contain 16 frozen icepacks of 0.6 litres.

Accessories: Twin chamber, twin compressor system. External freezer and refrigerator temperature indicator, low battery indicator; defrost switch; battery condition meter, all connecting cables and installation instructions.

2000 PRICES (EX-WORKS Australia)

Shipping volume/gross weight 0.44 m³ / 60.9 kg

Quantity/Price: Cabinet only 1/US\$ 1 900.00

* Measured with both the freezer and the refrigerator compressor turned on. Electricity consumption of the refrigerator compartment at 43°C with the freezer compressor turned off is 0.44 kWh/24 hours.

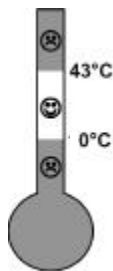

CODE PIS E3/70-M
Hot zone appliance

Photovoltaic solar refrigerator and icepack freezer. Model: CFS49 ISI

COMPANY NAME AND ADDRESS

Fortum AES Norway AS
Strandveien 50
N-1366 Lysaker, Norway
Telephone: 47 (67) 11 25 50
Fax: 47 (67) 11 25 45
E-mail: fortum.aes@fortum.com

SPECIFICATIONS

Vaccine storage capacity
Frozen icepack storage capacity
Manufacturers gross volume
External dimensions, H x W x L

	REFRIGERATOR	FREEZER	UNITS
Vaccine storage capacity	(20)	0	litres
Frozen icepack storage capacity	—	8	0.6 litre
Manufacturers gross volume	49	7.3	litres
External dimensions, H x W x L	51x107x455	—	cm.

PERFORMANCE AT

Icepack freezing, with vaccine
Holdover time during power cut
Electricity consumption:

With icepack freezing
Without icepack freezing

	32	43	32	43	degrees C°
Icepack freezing, with vaccine	—	—	2.4/16*	—	kg/hrs.
Holdover time during power cut	6.0	4.5	—	—	hours
Electricity consumption:					
With icepack freezing	—	—	++	++	kWh/24 hrs
Without icepack freezing	0.30	0.41	—	—	kWh/24 hrs

ENERGY REQUIREMENTS

Energy sources: 12 VDC

SPARES NEEDED PER 10 UNITS

	Part No.	Qty	Price / unit
Condenser fan	57000	3	US\$ 60.00
Compressor	57040	1	US\$ 180.00
Electronic device	57010	1	US\$ 185.00
Electronic thermostat & alarm/temp. display	57020	1	US\$ 250.00
Fuses for CFS49	57210	3 sets	US\$ 4.00
Charge controller NC C77	59050	1	US\$ 335.00

COMMENTS AND ACCESSORIES

Reports: NAPS (1996), Frigor (1997). Meets WHO/UNICEF Standard:E3/RF.4.

This appliance is not suitable for freezing icepacks if ambient temperature is permanently below +15° to +20°C

Freezer compartment should be used for icepacks only; it is not suitable for storage or freezing of vaccines. Accessories: Stand for refrigerator and the battery box unit; mounting tool kit, wire shelves with vaccine boxes, ventilated battery box with charging regulator integrated, cable with plug connection between battery box + refrigerator and battery box + array. Digital thermometer with LED alarm mounted on front of refrigerator. Wire shelves in freezing compartment designed to fit all types of icepack. Digital Amp and Volt meter for mounting at the wall.

A complete system is normally supplied with tubular plated, low antimony lead acid batteries or sealed, maintenance free lead acid batteries if air shipment required. Each vaccine refrigerator includes 25 safety boxes (E12/02) for the collection and disposal of 100 syringes and needles each.

2000 PRICES (FOB)

<i>Shipping volume/gross weight (refrigerator only - complete system)</i>			0.3 m ³ / 47 kg - 2.8 m ³ / 300 kg
Quantity/Price:	Cabinet only	US\$	1 500.00
	Complete solar system with stand	US\$	3 200.00

* icepack freezing trays can contain 5x0.6 litre icepacks.

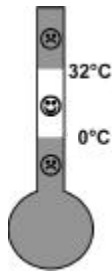

CODE **PIS E3/72-M**
Temperate zone appliance

**Icepack freezer, absorption type:
 FCW 20 EG/CF (Blue), Electric and Gas**

COMPANY NAME AND ADDRESS

Electrolux (Luxembourg) SARL
 14, op der Hei
 L-9809 Hosingen
 Luxembourg
Telephone: 352 920 731
Fax: 352 920 731 300
E-mail: *Pascal.Vannier@notes.electrolux.lu*

SPECIFICATIONS

Frozen icepack storage capacity
Manufacturers gross volume
External dimensions, H x W x L

	REFRIGERATOR	FREEZER	UNITS
	—	14	0.6 litres
	—	18	litres
	—	72x63x68	cm

PERFORMANCE AT

Icepack freezing, with vaccine
Icepack freezing, without vaccine
Holdover time during power cut
Power consumption: electricity
Power consumption: LP gas

	32	43	32	43	degrees C°
	—	—	++	++	kg/hrs
	—	—	(2.4/24)	++	kg/hrs
	—	—	—	—	hours
	—	—	(2.9)	++	kWh/24 hrs
	—	—	(0.6)	—	kg/24 hrs

ENERGY REQUIREMENTS

Energy sources: 220 V + 12V + LP Gas

SPARES NEEDED PER 10 UNITS

	Part No.	Qty	Price / unit		
Heating element 220V	296.9730.02	2	XEU	7.35	(US\$ 6.68)
Thermocouple	292.8742.04	2	XEU	2.34	(US\$ 2.13)
Safety device	292.2006.01	1	XEU	6.04	(US\$ 5.49)
Burner jet KZ 21/28 mbar	296.0082.11	2	XEU	5.79	(US\$ 5.26)

COMMENTS AND ACCESSORIES

Reports: CRL A.9280 (1989), Electrolux (1995); Meets WHO/UNICEF Standard:E3/FR4.

This item is colored blue, (formerly it was yellow). Specify the color required when ordering visible spare parts (hinges, etc.).

2000 PRICES (FOT Luxembourg)

Shipping volume/gross weight 0.45 m³ / 36.5 kg

Quantity/Price*:					
1-39	XEU	757.00	(US\$	688.18)	
40-99	XEU	719.00	(US\$	653.64)	
100+	XEU	683.00	(US\$	620.91)	

* *Cost of export packing for sea freight not included in price (allow approximately XEU 49 (US\$ 44.54) per appliance.*

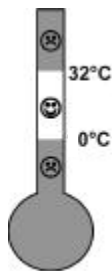

CODE **PIS E3/73-M**
Temperate zone appliance

Icepack freezer, absorption type:
FCW 20 EK/CF (Blue), Electric & Kerosene

COMPANY NAME AND ADDRESS

Electrolux (Luxembourg) SARL
 14, op der Hei
 L-9809 Hosingen
 Luxembourg
Telephone: 352 920 731
Fax: 352 920 731 300
E-mail: *Pascal.Vannier@notes.electrolux.lu*

SPECIFICATIONS

Frozen icepack storage capacity
Manufacturers gross volume
External dimensions, H x W x L
Burner type

REFRIGERATOR	FREEZER	UNITS
—	14	0.6 litres
—	18	litres
—	72x63x68	cm
—	Aladdin 32	

PERFORMANCE AT

Icepack freezing, with vaccine
Icepack freezing, without vaccine
Holdover time during power cut
Power consumption: electricity
Power consumption: kerosene

32	43	32	43	degrees C°
—	—	—	—	kg/hrs
—	—	2.4/24	++	kg/hrs
—	—	(11)	++	hours
—	—	2.70	++	kWh/24 hrs
—	—	0.65	—	lts/24 hrs

ENERGY REQUIREMENTS

Energy sources: 220V + 12V + Kerosene

SPARES NEEDED PER 10 UNITS

	Part No.	Qty	Price / unit		
Wick	292.8551.06	4	XEU	3.19	(US\$ 2.90)
Lamp glass	292.8551.02	3	XEU	24.70	(US\$ 22.45)
Flue brush	292.8557.01	3	XEU	5.00	(US\$ 4.55)
Switch	292.9865.00	2	XEU	2.29	(US\$ 2.08)
Heating element, 220V	296.9730.02	2	XEU	7.35	(US\$ 6.68)

COMMENTS AND ACCESSORIES

Reports: UNIVALLE E3/3000-07-97 (1997), Electrolux (1995); Meets WHO/UNICEF Standard: E3/FR3.

This item is colored blue, (formerly it was yellow). Specify the color required when ordering visible spare parts (hinges, etc.).

2000 PRICES (FOT Luxembourg)

Shipping volume/gross weight *0.45 m3 / 39.3 kg*

Quantity/Price*:	1-39	XEU	925.00	(US\$	840.91)
	40-99	XEU	879.00	(US\$	799.09)
	100+	XEU	835.00	(US\$	759.09)

* *Cost of export packing for sea freight not included in price (allow approximately XEU 49.00 (US\$ 44.54) per appliance.*

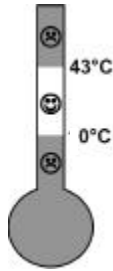

CODE PIS E3/75-M
Hot zone appliance

**Icelined refrigerator, compression type:
Model MK 074**

COMPANY NAME AND ADDRESS

Vestfrost A/S
P. O. Box 2079
Spangsbjerg Mollevej 100
DK 6705 Esbjerg 0, Denmark
Telephone: 45 (79) 14 22 22
Fax: 45 (79) 14 23 55
E-mail: export@vestfrost.dk

SPECIFICATIONS

Vaccine storage capacity
Manufacturers gross volume
External dimensions, H x W x L
The cooling refrigerant is R134A

	REFRIGERATOR	FREEZER	UNITS
Vaccine storage capacity	20	—	litres
Manufacturers gross volume	46*	5	litres
External dimensions, H x W x L	85x65x72	—	cm

PERFORMANCE AT

	32	43	32	43	degrees C°
Icepack freezing, with vaccine	—	—	++	3.0	kg/hrs.
Icepack freezing, without vaccine	—	—	—	—	kg/hrs.
Holdover time during power cut**	++	32.5	—	—	hours
Power consumption: electricity	++	1.62	—	—	kWh/24 hrs
Thermostat setting:					
Continuous energy	—	7	—	7	
Intermittent energy	—	—	—	7	

ENERGY REQUIREMENTS

Energy sources: 220 VAC/50 Hz
Available in various voltages: 115, 200, 240 VAC, 50 or 60 Hz.
Minimum of 8 hours electricity needed per 24 hours at 43°C°
Voltage stabilizer recommended where power supply is intermittent.

SPARES NEEDED PER 10 UNITS

	Part No.	Qty	Price / unit		
Compressor, Danfoss TL5 G	03.6038602	1	XEU	62.72	(US\$ 57.02)
Starting device for compressor	02.7038197	1	XEU	6.13	(US\$ 5.57)
Evaporator thermostat	02.7038016	1	XEU	7.38	(US\$ 6.71)
Ice-lining thermostat	02.6520066	1	XEU	7.38	(US\$ 6.71)
Filter/drier type XH 9 (20 grs)	02.6538053	1	XEU	2.83	(US\$ 2.57)
Alu-cylinder with R134A (1000 grs)	04.9954073	1	XEU	28.80	(US\$ 26.18)
Basket	02.6938012	1	XEU	6.67	(US\$ 6.06)

COMMENTS AND ACCESSORIES

Reports: CRL A.10592 (1995); Vestfrost 96002.2 (1996). Meets WHO/UNICEF Standard:E3/RF.3.

Equipped with LST compressor.

Accessories: locking lid.

Warning: Temperatures near the base of this icelined refrigerator are liable to fall below zero; this area is, therefore, not suitable for the storage of DPT, DT, TT and Hepatitis-B vaccine.

2000 PRICES (FCA Esbjerg)

Shipping volume/gross weight 0.65 m³ / 90 kg

Quantity/Price: 1/XEU 558.00 (US\$ 507.27)

* Gross volume excludes the volume taken by the icelining

** After intermittent power supply.

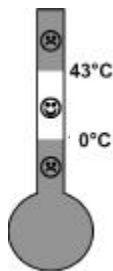

With CFC

CODE PIS E3/76

Hot zone appliance

Solar thermal vaccine refrigerator and icepack freezer

COMPANY NAME AND ADDRESS

Comesse Soudure SA

88390 Chaumousey

France

Telephone: 33 (3) 29 66 85 48

Fax: 33 (3) 29 66 80 94

E-mail: comesse.JC@dial.oleane.com

SPECIFICATIONS

Vaccine storage capacity

Manufacturers gross volume

External dimensions, H x W x L

Package captor

Cabinet + evaporator

Support

REFRIGERATOR

38

200

60x80x60

160 m³ = 130 kg1.40 m³ = 160 kg0.50 m³ = 50 kg

FREEZER

0

5

—

UNITS

litres

litres

cm.

PERFORMANCE AT

Icepack freezing, with vaccine

Icepack freezing, without vaccine

Internal temperatures, minimum

Internal temperatures, maximum

No sun autonomy

Power consumption

Temperatures recorded during day/night (+43/+20°C) tests:

32

43

32

43

degrees C

—

—

2/24

2/24

kg/hrs

—

—

2/24

2/24

kg/hrs

+2

-1.5

-10

-13

degrees C

+5

+4

-18

-12

degrees C

9

5

--

--

days

0

Minimum 0; Maximum +4°C°

ENERGY REQUIREMENTS

Energy sources: Solar energy (thermal)

Suitable for areas with 5 kwh/m²/day insolation

SPARES INCLUDED PER UNIT

Set of joints

Capillary

Filter

Qty

1

1

1

COMMENTS AND ACCESSORIES

Test Report: APMP/WHO (1992). Meets WHO/UNICEF Standard: E3/RF.5

Temperatures near the base of this refrigerator are liable to fall below zero so this area is not suitable for the storage of DPT, TT, DT and Hepatitis B vaccines.

Six consecutive days of good insolation are required for pull down before vaccines are stored (5 kWh/m²/day).

Guarantee: 5 years.

Refrigerator conceived and designed within the framework of a University- industry contact, Professor Félchon, University of Nancy, France.

2000 PRICES (FOB)

Shipping volume/weight

-- m³ / 340 kg.

Quantity/Price:	1 - 9	1/US\$	5 000.00
	10 - 49	1/US\$	4 000.00
	50 - 99	1/US\$	3 500.00
	100+	1/US\$	3 000.00



CODE PIS E3/77-M
Hot zone appliance

Solar photovoltaic refrigerator / icepack freezer, compression type: RFVB-134a

COMPANY NAME AND ADDRESS

Sun Frost
Box 1101
Arcata, California 95521 -1101
United States of America
Telephone: 1 (707) 822 90 95
Fax: 1 (707) 822 62 13
E-mail: info@sunfrost.com

SPECIFICATIONS

Vaccine storage capacity
Manufacturers gross volume
External dimensions, H x W x L

	REFRIGERATOR	FREEZER	UNITS
Vaccine storage capacity	38.7	—	litres
Manufacturers gross volume	56.8	32.5	litres
External dimensions, H x W x L	88x70x80	—	cm

PERFORMANCE AT

Icepack freezing, with vaccine
Icepack freezing, without vaccine
Holdover time during power cut
Power consumption

	32	43	32	43	degrees C
Icepack freezing, with vaccine	—	—	2.3/24	2.2/24	kg/hrs
Icepack freezing, without vaccine	--	--	--	--	kg/hrs
Holdover time during power cut	3.1	2.0	--	--	hours
Power consumption					
With icepack freezing	--	--	0.44	0.64	kWh/24 hrs
Without icepack freezing	0.32	0.47	—	—	kWh/24 hrs

ENERGY REQUIREMENTS

Energy sources: 12VDC

SPARES NEEDED PER 10 UNITS

	Part No.	Qty	Price / unit
Electronic unit	102N3030	1	US\$ 125.00

COMMENTS AND ACCESSORIES

Reports: Univalle E3/2087-0597 (1997). Meets WHO/UNICEF Standard: E3/RF.4.

Freezer compartment should be used for icepacks only; it is not suitable for storage or freezing of vaccines.

Warning: Temperatures near the back wall of the refrigerating compartment are liable to fall below zero; this area is, therefore, not suitable for the storage of DPT, DT, TT and Hepatitis-B vaccine.

Performance is probably better than indicated. The appliance is undergoing new independent test since switching to a new compressor.

2000 PRICES (FOB)

Shipping volume/gross weight 1.67 m³/ 72 kg

Quantity/Price: Cabinet only US\$ 1555.00
Complete system US\$ 2400.00 to 3800.00

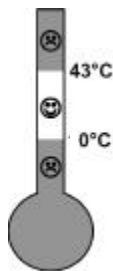

CODE PIS E3/79-M
Hot zone appliance

Photovoltaic solar refrigerator and icepack freezer: Model Dulas VC-150 F

COMPANY NAME AND ADDRESS

Dulas Ltd.
Dyfi Eco Park
Machynlleth, Powys SY20 8AX, Wales
United Kingdom
Telephone: 44 (1654) 70 53 00
Fax: 44 (1654) 70 30 00
E-mail: dulas@gn.apc.org

SPECIFICATIONS

Vaccine storage capacity
Frozen icepack storage capacity
Manufacturers gross volume
External dimensions, H x W x L

REFRIGERATOR	FREEZER	UNITS
85	0	litres
—	24	0.6 litres
127	63	litres
95x129x70	—	cm

PERFORMANCE AT

Icepack freezing, with vaccine
Icepack freezing, without vaccine
Holdover time during power cut
Electricity consumption:

	32	43	32	43	degrees C
Icepack freezing, with vaccine	—	—	8.7/24	6.4	kg/hrs
Icepack freezing, without vaccine	—	—	—	—	kg/hrs
Holdover time during power cut	4.6	3.1	7.2	4.8	hours
Electricity consumption:					
With icepack freezing	++	++	1.9*	2.4*	kWh/24 hrs
Without icepack freezing	0.8*	1.5*	++	++	kWh/24 hrs

ENERGY REQUIREMENTS

Energy sources: 12 or 24 volts DC (please specify when ordering)

SPARES NEEDED PER 10 UNITS

	Qty	Price
Spares kit for cabinet (as specified by WHO, see below)	1	GB£ 1 500.00 (US\$ 2 343.75)

COMMENTS AND ACCESSORIES

Reports: UNIVALLE E3/2088-12-97 (1997); Meets WHO/UNICEF Standard: E3/RF.4.

Suitable for solar applications. Freezer compartment should be used for icepacks only; it is not suitable for storage or freezing of vaccines. Combined refrigerator/freezer uses two independent refrigeration systems. Freezer may be switched off when not required. Icepacks can be stored when frozen and fresh icepacks added for freezing.

Accessories: Locking door, external refrigerator thermometer, vaccine storage baskets with air circulation, icepack freezing baskets.

Refrigerator spares kit for the cabinet for 10 units as specified by WHO/UNICEF comprises: 2 charge regulators; 1 array cable, 15 meter, 16mm²; 1 compressor; 3 spare compressor control units; 3 thermostats; 2 spare fan sets. Spare modules and battery sets also available.

2000 PRICES (FOB)

Shipping volume/gross weight 1.26 m³ / 165 kg

Quantity/Price:	1-10	1/GB£	1 562.00	(US\$	2 440.63)
	11+		Price on application		
	Complete system	GB£	2 800.00	(US\$	4 375.00)

* Measured with both the freezer and the refrigerator compressor turned on.

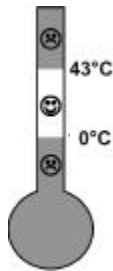

CODE PIS E3/80-M
Hot zone appliance

Icepack freezer, compression:
TFW 800 (958.4575.10)

COMPANY NAME AND ADDRESS

Electrolux (Luxembourg) SARL
14, op der Hei
L-9809 Hosingen
Luxembourg
Telephone: 352 920 731
Fax: 352 920 731 300
E-mail: Pascal.Vannier@notes.electrolux.lu

SPECIFICATIONS

Frozen icepack storage capacity
Manufacturers gross volume
External dimensions, H x W x L

REFRIGERATOR	FREEZER	UNITS
—	145	0.6 litres
—	209	litres
—	160x72x60	cm

PERFORMANCE AT

Icepack freezing, with vaccine
Icepack freezing, without vaccine
Holdover time during power cut
Power consumption: electricity

32	43	32	43	degrees C°
—	—	++	++	kg/hrs.
—	—	++	87/112	kg/hrs.
—	—	++	(14)	hours
—	—	++	5.77	kWh/24 hrs

ENERGY REQUIREMENTS

Energy sources: 220 VAC/50Hz and 115VAC/60 Hz

SPARES NEEDED PER 10 UNITS	Part No.	Qty	Price		
Thermostat	205.4710.03	3	XEU	27.56	(US\$ 25.05)
Compressor	296.9701.06	1	XEU	138.33	(US\$ 125.75)
Compressor device	210.0088.03	3	XEU	80.00	(US\$ 72.73)
Motor protection	210.0971.02	1	XEU	10.22	(US\$ 9.29)

COMMENTS AND ACCESSORIES

Reports: GET 96-51513-4200 WI/BO (1996), Electrolux (1995). Meets WHO/UNICEF Standard: E3/FR.2..

2000 PRICES (FOT Luxembourg)

Shipping volume/gross weight -- m3/ [90] kg.

Quantity	Price/unit		
1-39	XEU	1 576.00	(US\$ 1 432.73)
40-99	XEU	1 497.00	(US\$ 1 360.91)
100+	XEU	1 422.00	(US\$ 1 292.73)

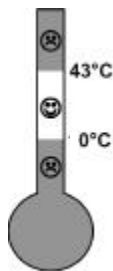

CODE PIS E3/81-M
Hot zone appliance

**Icelined refrigerator, compression type:
Model MK 204 (New Generation)**

COMPANY NAME AND ADDRESS

Vestfrost A/S
P. O. Box 2079
Spangsbjerg Mollevej 100
DK 6705 Esbjerg 0, Denmark
Telephone: 45 (79) 14 22 22
Fax: 45 (79) 14 23 55
E-mail: export@vestfrost.dk

SPECIFICATIONS

Vaccine storage capacity
Manufacturers gross volume
External dimensions, H x W x L
The cooling refrigerant is R134A

	REFRIGERATOR	FREEZER	UNITS
Vaccine storage capacity	63*	—	litres
Manufacturers gross volume	137**	—	litres
External dimensions, H x W x L	85x60x92	—	cm.

PERFORMANCE AT

	32	43	32	43	degrees C°
Icepack freezing, with vaccine	—	—	—	—	kg/hrs.
Icepack freezing, without vaccine	—	—	—	—	kg/hrs.
Holdover time during power cut***	46	10	—	—	hours
Power consumption: electricity	0.60	1.41	—	—	kWh/24 hrs
Thermostat setting: Continuous energy	7.5	7.5	—	—	

ENERGY REQUIREMENTS

Energy sources: 220 VAC/50 Hz
Available in various voltages: 115, 240 VAC, 50 or 60 Hz.
Minimum of 8 hours electricity needed per 24 hours at 43°C°
Voltage stabilizer recommended where power supply is intermittent.

SPARES NEEDED PER 10 UNITS

	Part No.	Qty	Price / unit		
Compressor, Danfoss FR6G	03.6038754	1	XEU	69.22	(US\$ 62.93)
Starting device (Relay)	02.7038089	1	XEU	7.20	(US\$ 6.55)
Starting device (Capacitor)	6520004	1	XEU	12.48	(US\$ 11.35)
Electronic thermostat	02.6520154	1	XEU	14.65	(US\$ 13.32)
Thermometer	02.7020037-01	1	XEU	7.83	(US\$ 7.12)
Filter/drier type XH 9 (20 grs)	02.6538053	1	XEU	2.83	(US\$ 2.57)
Alu-cylinder with R134A (1000 grs)	04.9954073	1	XEU	28.80	(US\$ 26.18)
Basket for vaccine storage	02.6938012	1	XEU	4.85	(US\$ 4.41)

COMMENTS AND ACCESSORIES

Reports: Bureau Veritas T99109 (2000) Meets WHO/UNICEF Standard:E3/RF.3.

Appliance equipped with HST compressor.

Accessories: external electronic temperature reading, 5 vaccine storage baskets, locking lid.

2000 PRICES (FCA Esbjerg)

Shipping volume/gross weight 0.73 m³ / 77 kg.

Quantity/Price: XEU 495.00 (US\$ 450.00)

* Vaccine storage capacity measured with vaccines baskets in place

** Gross volume excludes the volume taken by the icelining

*** After intermittent power supply..

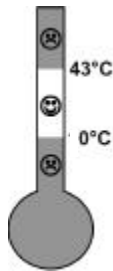

CODE PIS E3/82-M
Hot zone appliance

**Icelined refrigerator, compression type:
Model MK 304 (New Generation)**

COMPANY NAME AND ADDRESS

Vestfrost A/S
P. O. Box 2079
Spangsbjerg Mollevej 100
DK 6705 Esbjerg 0, Denmark
Telephone: 45 (79) 14 22 22
Fax: 45 (79) 14 23 55
E-mail: export@vestfrost.dk

SPECIFICATIONS

Vaccine storage capacity
Manufacturers gross volume
External dimensions, H x W x L
The cooling refrigerant is R134A

	REFRIGERATOR	FREEZER	UNITS
Vaccine storage capacity	108*	—	litres
Manufacturers gross volume	204**	—	litres
External dimensions, H x W x L	85x60x126	—	cm.

PERFORMANCE AT

	32	43	32	43	degrees C°
Icepack freezing, with vaccine	—	—	—	—	kg/hrs.
Icepack freezing, without vaccine	—	—	—	—	kg/hrs.
Holdover time during power cut***	49	15	—	—	hours
Power consumption: electricity	0.80	1.67	—	—	kWh/24 hrs
Thermostat setting: Continuous energy	7	7	—	—	

ENERGY REQUIREMENTS

Energy sources: 220 VAC/50 Hz
Available in various voltages: 115, 240 VAC, 50 or 60 Hz.
Minimum of 8 hours electricity needed per 24 hours at 43°C°
Voltage stabilizer recommended where power supply is intermittent.

SPARES NEEDED PER 10 UNITS

	Part No.	Qty	Price / unit		
Compressor, Danfoss FR8 5G	03.6038480	1	XEU	75.13	(US\$ 68.30)
Starting device (Relay)	02.7038049	1	XEU	7.20	(US\$ 6.55)
Starting device (Capacitor)	6520004	1	XEU	12.48	(US\$ 11.35)
Electronic thermostat	02.6520154	1	XEU	14.65	(US\$ 13.32)
Thermometer	02.7020037-01	1	XEU	7.83	(US\$ 7.12)
Fan	02.6000902	1	XEU	16.54	(US\$ 15.04)
Filter/drier type XH 9 (20 grs)	02.6538053	1	XEU	2.83	(US\$ 2.57)
Alu-cylinder with R134A (1000 grs)	04.9954073	1	XEU	28.80	(US\$ 26.18)
Basket for vaccine storage	02.6938012	1	XEU	4.85	(US\$ 4.41)

COMMENTS AND ACCESSORIES

Reports: Bureau Veritas TR99108 (2000) Meets WHO/UNICEF Standard:E3/RF.3.

Appliance equipped with HST compressor.

Accessories: external electronic temperature reading, 7 vaccine storage baskets, locking lid.

2000 PRICES (FCA Esbjerg)

Shipping volume/gross weight 0.98 m³ / 110 kg.

Quantity/Price: XEU 585.00 (US\$ 531.82)

* Vaccine storage capacity measured with vaccines baskets in place

** Gross volume excludes the volume taken by the icelining

*** After intermittent power supply.

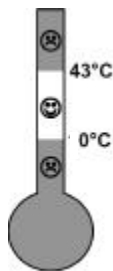

With CFC

CODE PIS E3/83

Hot zone appliance

Photovoltaic solar refrigerator & icepack freezer: Model TBP VR 50

COMPANY NAME AND ADDRESS

TATA BP Solar India Ltd.
 Plot Number 78, Electronic City
 Hosur Road
 Bangalore 561 229, India
 Telephone: 91 (80) 852 10 16
 Fax: 91(80) 852 09 72/01 16

SPECIFICATIONS

Vaccine storage capacity
 Manufacturers gross volume
 External dimensions, H x W x L

REFRIGERATOR	FREEZER	UNITS
18	—	litres
40	5	litres
0.64x0.63x0.87	—	ms.

PERFORMANCE AT

Icepack freezing, with vaccine
 Icepack freezing, without vaccine
 Holdover time during power cut
 Electricity consumption:

	32	43	32	43	degrees C°
Icepack freezing, with vaccine	—	—	2.4/9	2/21	kg/hrs.
Icepack freezing, without vaccine	—	—	—	—	kg/hrs.
Holdover time during power cut	5.5	6.0	—	—	hours
Electricity consumption:					
With icepack freezing	—	—	0.74	1.5	kWh/24 hrs
Without icepack freezing	0.5	1.1	—	—	kWh/24 hrs

ENERGY REQUIREMENTS

Energy sources: 12 VDC

SPARES NEEDED PER 10 UNITS

	Part No.	Qty	Price/unit
Complete spares kit (as specified by WHO) as per details below:		1	US\$ 2 330.00
Photovoltaic module TBP 1275	N032188	1	
Battery 6-363, dry charged	N036014	2	
Battery charge controller	N030001	2	
Compressor 12 VDC	N043999	1	
Compressor electronics	-	3	
Temperature sensor	N239049	2	
Array cable 2x10mm ² - 10m	N239002	1	
Lid seals	N300157	2	
Fuse, 15A		5	

COMMENTS AND ACCESSORIES

Reports: AIT (1996). Meets WHO/UNICEF Standard: E3/RF4.

Freezer compartment should be used for icepacks only; it is not suitable for storage or freezing of vaccines.

2000 PRICES (FOB)

Shipping volume / weight refrigerator: 0.74 m³ / 60 kg complete system: 2.8 m³ / 200 kg

Quantity/Price:		US\$	
	Refrigerator only	1 530.00	
	Complete system	2 950.00	

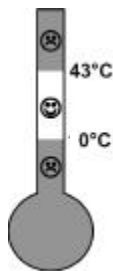

CODE PIS E3/84-M
Hot zone appliance

Refrigerator & freezer, absorption type
Model V 170 GE Gas and Electric

COMPANY NAME AND ADDRESS

Sibir International AB
S-105 45 Stockholm
Sweden

Telephone: 46 (8) 738 61 18;

Fax: 46 (8) 738 75 38

E-mail: roxana.bolling@sibir.com

SPECIFICATIONS

Vaccine storage capacity
Manufacturers gross volume
External dimensions, H x W x L

	REFRIGERATOR	FREEZER	UNITS
Vaccine storage capacity	(55)	(36)	litres
Manufacturers gross volume	170	47	litres
External dimensions, H x W x L	145x59x62	—	cm

PERFORMANCE AT

	32	43	32	43	degrees C°
Icepack freezing, with vaccine	—	—	3.6/24	1.2/24	kg/hrs.
Icepack freezing, without vaccine	—	—	++	++	kg/hrs.
Holdover time during power cut	3.0	1.5	++	++	hours
Power consumption: electricity	6.3	8.3	—	—	kWh/24 hrs
Power consumption: gas	0.6	0.8	—	—	lts/24 hrs.

ENERGY REQUIREMENTS

Energy sources: LP gas or 230VAC/50Hz; other voltages on request.

For other voltages (120 or 240 VAC) heating elements can be ordered separately.

SPARES NEEDED PER 10 UNITS	Part No.	Qty	Price / unit		
Thermostat (gas/electric)	200 71 99-04/1	2	SEK	215.00	(US\$ 24.08)
Electric heater, 230VAC	17 37 42-24/8	2	SEK	114.00	(US\$ 12.77)
Thermocouple	293 14 96-04/2	2	SEK	48.00	(US\$ 5.38)
Safety valve	293 16 57-01/5	2	SEK	88.00	(US\$ 9.85)
Burner jet No. 58	200 74 19-21/7	2	SEK	43.00	(US\$ 4.82)

COMMENTS AND ACCESSORIES

Reports: GET, May 1997; Meets WHO/UNICEF Standard: E3/RF2.

Packed in a seaworthy plywood case. Accessories: Lockable vaccine door; external thermometer; level indicator; remote flame indicator; fuel supply interlock. Supplied with 4 ice-trays. Spare burner jet, No. 58, needed. Operates on butane or propane.

Warning: Temperatures near the evaporator on the back wall of the refrigerating compartment are liable to fall below zero; this area is, therefore, not suitable for the storage of DPT, DT, TT and Hepatitis-B vaccine.

2000 PRICES (FCA Motala/Sweden)*

Shipping volume/gross weight 0.725 m³ / 86 kg
Quantity/Price: 1-400 SEK 7 436.00 (US\$ 832.70)

* Prices exclusively for UN agencies

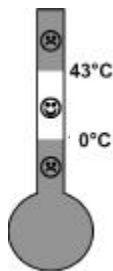

CODE PIS E3/85-M
Hot zone appliance

Refrigerator & freezer, absorption type
Model V 170 KE Kerosene and Electric

COMPANY NAME AND ADDRESS

Sibir International AB
S-105 45 Stockholm
Sweden

Telephone: 46 (8) 738 61 18

Fax: 46 (8) 738 75 38

E-mail: roxana.bolling@sibir.com

SPECIFICATIONS

Vaccine storage capacity
Manufacturers gross volume
External dimensions, H x W x L
Type of burner

	REFRIGERATOR	FREEZER	UNITS
Vaccine storage capacity	(55)	(36)	litres
Manufacturers gross volume	170	47	litres
External dimensions, H x W x L	165x59x59	—	cm
Type of burner	Aladdin 23E		

PERFORMANCE AT

	32	43	32	43	degrees C°
Icepack freezing, with vaccine	—	—	2.4/24	0.6/15	kg/hrs.
Icepack freezing, without vaccine	—	—	++	++	kg/hrs.
Holdover time during power cut	3.6	2.4	++	++	hours
Power consumption: electricity	++	++	—	—	kWh/24 hrs
Power consumption: kerosene	1.2	1.4	—	—	lts/24 hrs.

ENERGY REQUIREMENTS

Energy sources: Kerosene or 230VAC/50Hz.
120 VAC or 240 VAC available on special request.

SPARES NEEDED PER 10 UNITS	Part No.	Qty	Price / unit		
Wick (cotton)	289 00 62-00/9	50	SEK	51.00	(US\$ 5.71)
Glass lamp	293 28 92-01/7	20	SEK	244.00	(US\$ 27.32)
Flue baffle	293 03 77-01/1	10	SEK	69.00	(US\$ 7.73)
Wick cleaner	289 00 65-00/2	2	SEK	31.00	(US\$ 3.47)
Electric heater, 230 VAC	17 37 42-30/5	2	SEK	104.00	(US\$ 11.65)
Flue brush	15 74 18-00/5	10	SEK	78.00	(US\$ 8.73)

COMMENTS AND ACCESSORIES

Reports: GET, February 1998; Meets WHO/UNICEF Standard: E3/RF2.

Packed in a seaworthy plywood case. Accessories: Locking door(s); external thermometer; level indicator; day/night temperature indicator; Stabilizer tank. Supplied with standard package of essential spare parts for the Aladdin 23E burner: 5 wicks, 3 wick cleaners, 3 lamp glasses, 1 lamp glass insert, 1 flue brush, 1 funnel, 1 instruction manual, 1 spare parts list.

Warning 1: Temperatures near the evaporator near the back wall of the refrigerating compartment are liable to fall below zero; this area is, therefore, not suitable for the storage of DPT, DT, TT and Hepatitis-B vaccine.

Warning 2: The appliance is equipped with a manually operated device, for use when operating on kerosene, that can be put in a day or a night position. It allows internal temperatures to stay between 0-8°C, while outside temperatures change during the day/night cycle (32°C/15°C). **If the device stays in the 'day' position, temperatures are likely to fall below 0°C in areas where night temperatures are around 15°C or lower.**

2000 PRICES (FCA Motala/Sweden)*

Shipping volume/gross weight 0.848 m³ / 118 kg
Quantity/Price: 1-400 SEK 9 879.00 (US\$ 1 106.27)

* Prices exclusively for UN agencies



CODE PIS E3/86-M
Hot zone appliance

Refrigerator & freezer, absorption type
Model V 110 GE Gas and Electric

COMPANY NAME AND ADDRESS

Sibir International AB
S-105 45 Stockholm
Sweden

Telephone: 46 (8) 738 61 18

Fax: 46 (8) 738 75 38

E-mail: roxana.bolling@sibir.com

SPECIFICATIONS

Vaccine storage capacity
Manufacturers gross volume
External dimensions, H x W x L
Type of burner

	REFRIGERATOR	FREEZER	UNITS
Vaccine storage capacity	17	—	litres
Manufacturers gross volume	110	15	litres
External dimensions, H x W x L	102x59x62	—	cm
Type of burner	SIBIR LPG		

PERFORMANCE AT

	32	43	32	43	degrees C°
Icepack freezing, with vaccine	—	—	2.4/20	0.6/14	kg/hrs.
Icepack freezing, without vaccine	—	—	++	++	kg/hrs.
Holdover time during power cut	3.0	1.4	++	++	hours
Power consumption: electricity	++	++	—	—	kWh/24 hrs
Power consumption: gas	0.36	0.5	—	—	lts/24 hrs.

ENERGY REQUIREMENTS

Energy sources: LP Gas or 230VAC/50Hz.
120 VAC or 240 VAC available on special request.

SPARES NEEDED PER 10 UNITS	Part No.	Qty	Price		
Thermostat (gas/electric)	200 7199-04/1	2	SEK 215.00	(US\$ 24.08)	
Electric heater, 230VAC	173 738-26/1	2	SEK 126.00	(US\$ 14.11)	
Thermocouple	293 1496-04/2	2	SEK 48.00	(US\$ 5.38)	
Safety valve	293 1657-01/5	2	SEK 88.00	(US\$ 9.85)	
Burner jet No.14	172819-02/1	2	SEK 35.00	(US\$ 3.92)	

COMMENTS AND ACCESSORIES

Reports: Get 1998; Meets WHO/UNICEF Standard: E3/RF.2

Packed in a seaworthy plywood case. Accessories: Lockable door(s), external thermometer, level indicator, remote flame indicator, fuel supply interlock. Supplied with 4 ice-trays. Spare burner jet, No. 14, needed. Operates on butane or propane.

Warning: Temperatures near the back wall of the top shelf of the refrigerating compartment are liable to fall below zero; this area is, therefore, not suitable for the storage of DPT, DT, TT and Hepatitis B vaccine.

2000 PRICES (FCA Motala/Sweden)*

Shipping volume/gross weight 0.518 m³ / 70 kg
Quantity/Price: 1-400 SEK 6 350.00 (US\$ 711.09)

* Prices exclusively for UN agencies

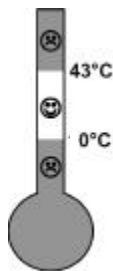

CODE PIS E3/87-M
Temperate zone appliance

Refrigerator, absorption type
Model V 110 KE Kerosene and Electric

COMPANY NAME AND ADDRESS

Sibir International AB
S-105 45 Stockholm
Sweden

Telephone: 46 (8) 738 61 18;

Fax: 46 (8) 738 75 38

E-mail: roxana.bolling@sibir.com

SPECIFICATIONS

Vaccine storage capacity
Manufacturers gross volume
External dimensions, H x W x L
Type of burner

	REFRIGERATOR	FREEZER	UNITS
Vaccine storage capacity	17	—	litres
Manufacturers gross volume	110	15	litres
External dimensions, H x W x L	102x59x62	—	cm
Type of burner	Cosmos 10		

PERFORMANCE AT

	32	43	32	43	degrees C°
Icepack freezing, with vaccine	—	—	0.6/24	—	kg/hrs.
Icepack freezing, without vaccine	—	—	++	++	kg/hrs.
Holdover time during power cut		++	++	++	hours
Power consumption: electricity	++	++	—	—	kWh/24 hrs
Power consumption: kerosene	0.5	++	—	—	lts/24 hrs.

ENERGY REQUIREMENTS

Energy sources: Kerosene or 230VAC/50Hz.
120 VAC or 240 VAC available on special request.

SPARES NEEDED PER 10 UNITS	Part No.	Qty	Price / unit		
Wick (cotton)	62745-00/5	50	SEK	28.00	(US\$ 3.14)
Glass lamp	6 6704-02/4	20	SEK	90.00	(US\$ 10.08)
Flue baffle	2932667-01/3	10	SEK	33.00	(US\$ 3.70)
Wick cleaner	289 00 65-00/2	2	SEK	31.00	(US\$ 3.47)
Electric heater, 230 VAC	17 37 38-29/5	2	SEK	126.00	(US\$ 14.11)
Flue brush	151404-0/1	10	SEK	66.00	(US\$ 7.39)

COMMENTS AND ACCESSORIES

Reports: Get 1998; Meets WHO/UNICEF Standard: E3/RF.6

Packed in a seaworthy plywood case. Accessories: Locking door(s); external thermometer; level indicator; day/night regulating device. Supplied with standard package of essential spare parts for the Cosmos 10 burner: 5 wicks, 3 lamp glasses, 1 lamp glass insert, 1 flue brush, 1 funnel, 1 instruction manual, 1 spare parts list.

Warning: Temperatures near the back wall of the top shelf of the refrigerating compartment are liable to fall below zero; this area is, therefore, not suitable for the storage of DPT, DT, TT and Hepatitis B vaccine.

Warning 2: The appliance is equipped with a manually operated device, for use when operating on kerosene, that can be put in a day or a night position. It allows internal temperatures to stay between 0-8°C, while outside temperatures change during the day/night cycle (32°C/15°C). **If the device stays in the 'day' position, temperatures are likely to fall below 0°C in areas where night temperatures are around 15°C or lower.**

2000 PRICES (Ex Works Motala/Sweden)*

Shipping volume/gross weight 0.518 m³ / 70 kg
Quantity/Price: 1-400 SEK 7 186.00 (US\$ 804.70)

* Prices exclusively for UN agencies



CODE PIS E3/88 -M
Hot zone appliance

**Refrigerator and icepack freezer,
absorption: RCW 50 EG/CF (Blue)**

COMPANY NAME AND ADDRESS

Electrolux (Luxembourg) SARL
14, op der Hei
L-9809 Hosingen
Luxembourg
Telephone: 352 920 731
Fax: 352 920 731 300
E-mail: Pascal.Vannier@notes.electrolux.lu

SPECIFICATIONS

Vaccine storage capacity
Manufacturers gross volume
External dimensions, H x W x L
Frozen icepack storage capacity

REFRIGERATOR	FREEZER	UNITS
24	—	litres
70	—	litres
83 x 82 x 98 —		cm.
	4	0.6 litres

PERFORMANCE AT

Icepack freezing, with vaccine
Icepack freezing, without vaccine
Holdover time during power cut
Power consumption: electricity
Power consumption: LP gas

32	43	32	43	degrees C°
—	—	2.4/26	—	kg/hrs.
—	—	—	—	kg/hrs.
4.4	++	++	++	hours
2.5	3.5	2.52	++	kWh/24 hrs
0.43	0.54	—	—	kg/24 hrs.

ENERGY REQUIREMENTS

Energy sources: 230 V + 120V + LPGas
RCW 50 EG/CF is supplied with a 120 volt heating elements.

SPARES NEEDED PER 10 UNITS

	Part No.	Qty	Price/unit		
Flame failure device	292.2006.01	2	XEU	6.04	(US\$ 5.49)
Electrical heater, 230 VAC	296.9730.02	2	XEU	7.35	(US\$ 6.68)
Burner	296.0626.10	2	XEU	12.04	(US\$ 10.95)
Thermocouple	292.8742.02	2	XEU	2.34	(US\$ 2.13)

COMMENTS AND ACCESSORIES

Reports: GET (1998), Meets WHO/UNICEF Standard: E3/RF.6 as absorption refrigerator and E3/RF.2 as absorption refrigerator and icepack freezer with marginal failure in icepack freezing capacity: 2.4 kg in 26.5 hours instead of 24 hours when functioning on gas.

Accessories: Locking door(s), external thermometer, and gas jet 30 mbar. Removable partition between freezing and refrigerator compartments also provided.

2000 PRICES (FOT Luxembourg)

Shipping volume / weight 0.73 m³ / 70 kg

Quantity/Price:	1-39:	XEU	1 234.00	(US\$	1 121.82)
	40-99:	XEU	1 172.00	(US\$	1 065.45)
	100+:	XEU	1 114.00	(US\$	1 012.73)
Export packaging per appliance		XEU	49.00	(US\$	44.55)

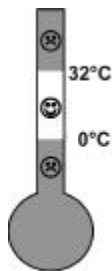

CODE **PIS E3/89-M**
Temperate zone appliance

Refrigerator & freezer, absorption type
Model PR 245 K/E Kerosene and Electric

COMPANY NAME AND ADDRESS

Zero Appliances
P.O. Box 426, Edenvale 1610
Kempton Park, Gauteng
South Africa
Telephone: 27 (11) 393 41 40
Fax: 27 (11) 393 4 119
E-mail: zero@elink.co.za

SPECIFICATIONS

Vaccine storage capacity
Manufacturers gross volume
External dimensions, H x W x L
Type of burner

	REFRIGERATOR	FREEZER	UNITS
Vaccine storage capacity	18	—	litres
Manufacturers gross volume	107	20	litres
External dimensions, H x W x L	142x60x68	—	cm
Type of burner	Aladdin 32		

PERFORMANCE AT

	32	43	32	43*	degrees C°
Icepack freezing, with vaccine	—	—	1.8/14*	++	kg/hrs.
Icepack freezing, without vaccine	—	—	++	++	kg/hrs.
Holdover time during power cut	3.2	++	++	++	hours
Power consumption: electricity	++	++	—	—	kWh/24 hrs
Power consumption: kerosene	0.46	++	—	—	lts/24 hrs.

ENERGY REQUIREMENTS

Energy sources: Kerosene or 220VAC/50Hz; other voltages on request.

SPARES NEEDED PER 10 UNITS	Part No.	Qty	Price / unit	
Wick (cotton)	ZP99908	10	US\$	6.40
Metal flue with window	STF100	1	US\$	23.50
Door gasket/seal	PL280GA15	1	US\$	8.30
External thermometer	IMP55	1	US\$	16.00
Electric heater (220 volt)	ELEM23	2	US\$	13.50
Flame spreader	ZP990210	2	US\$	3.75
Flue Baffle	70BAFFLE	2	US\$	4.50
Flue Brush	BF60	2	US\$	2.50

COMMENTS AND ACCESSORIES

Reports: CSIR, ESH98-0237 (1998); Meets WHO/UNICEF Standard: E3/RF2 when tested in an ambient temperature of 32°C°

Other spares on request. Packed in a seaworthy wooden case/crate. Accessories: Lockable door; external thermometer; silent operation; adjustable leveling feet; Supplied spares: 5 wicks; 3 flues; 3 flame spreaders; 5 wick cleaners; 1 gallery; 1 flue brush.

Warning 1: Temperatures near the back wall of the refrigerating compartment are liable to fall below zero; this area is, therefore, not suitable for the storage of DPT, DT, TT and Hepatitis B vaccine.

Warning 2: When 4 icepacks of 0.6 liter are frozen at the same time, the appliance does not maintain the correct temperature in the vaccine load. When larger quantities of icepacks need to be frozen, it is therefore recommended to freeze small numbers (2 or 3) successively, while carefully monitoring the temperature of the vaccine load.

2000 PRICES (Ex Works Chloorkop, Kempton Park, South Africa)

Shipping volume/gross weight (crated) 0.98 m³ / 103.7 kg

Quantity/Price:		US\$
1-20		670.00
21-50		655.00
51-100		640.00
101-200		625.00
201-400		611.00

* See comment box

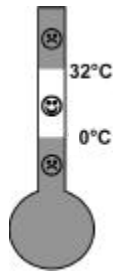

CODE PIS E3/90-M
Temperate zone appliance

Refrigerator & freezer, absorption type
Model GR 245 G/E Gas and Electric

COMPANY NAME AND ADDRESS

Zero Appliances
P.O. Box 426, Edenvale 1610
Kempton Park, Gauteng
South Africa
Telephone: 27 (11) 393 41 40
Fax: 27 (11) 393 4 119
E-mail: zero@elink.co.za

SPECIFICATIONS

Vaccine storage capacity
Manufacturers gross volume
External dimensions, H x W x L

	REFRIGERATOR	FREEZER	UNITS
Vaccine storage capacity	18	—	litres
Manufacturers gross volume	107	20	litres
External dimensions, H x W x L	142x60x68	—	cm

PERFORMANCE AT

	32	43	32	43*	degrees C°
Icepack freezing, with vaccine	—	—	1.8/13*	++	kg/hrs.
Icepack freezing, without vaccine	—	—	++	++	kg/hrs.
Holdover time during power cut	3.0	++	++	++	hours
Power consumption: electricity	++	++	—	—	kWh/24 hrs
Power consumption: gas	0.5	++	—	—	lts/24 hrs.

ENERGY REQUIREMENTS

Energy sources: LP Gas or 220VAC/50Hz; other voltages on request.

SPARES NEEDED PER 10 UNITS	Part No.	Qty	Price/unit
Thermostat (gas/electric)	IMP33	2	US\$ 43.00
Electric heater, 220VAC	ELEM23	2	US\$ 13.50
Thermocouple	IMP10	2	US\$ 10.75
Safety valve	IMP25	2	US\$ 9.50
Burner jet No.15	JFGE20	2	US\$ 1.30
Door lock	SULOCK05	2	US\$ 6.60
Door gasket/seal	PL280GA15	1	US\$ 8.30
External thermometer	IMP55	1	US\$ 16.00
Gas ignitor	IMP20	2	US\$ 2.50
Gas regulator	GRBN007	1	US\$ 6.50

COMMENTS AND ACCESSORIES

Reports: CSIR, ESH98-0236 (1998); Meets WHO/UNICEF Standard: E3/RF2 when tested in an ambient temperature of 32°C°

Accessories: Lockable door, external thermometer, flame indicator, adjustable leveling feet, gas safety device, silent operation, push button lighting device. Other spares available on special request. Packed in a seaworthy case/crate.

Warning 1: Temperatures near the back wall of the refrigerating compartment are liable to fall below zero; this area is, therefore, not suitable for the storage of DPT, DT, TT and Hepatitis B vaccine.

2000 PRICES (Ex Works Chloorkop, Kempton Park, South Africa)

Shipping volume/gross weight(crated) 0.98 m³ / 100 kg

Quantity/Price:		US\$	
1-20		615.00	
21-50		601.00	
51-100		587.00	
101-200		572.00	
201-400		559.00	

* See comment box

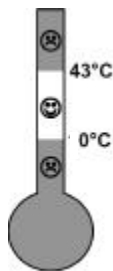

CODE PIS E3/91 -M
Hot zone appliance

**Refrigerator and icepack freezer,
absorption: RCW 50 EK (Blue) (921.2530.01)**

COMPANY NAME AND ADDRESS

Electrolux (Luxembourg) SARL
14, op der Hei
L-9809 Hosingen
Luxembourg
Telephone: 352 920 731
Fax: 352 920 731 300
E-mail: Pascal.Vannier@notes.electrolux.lu

SPECIFICATIONS

Vaccine storage capacity
Manufacturers gross volume
External dimensions, H x W x L
Type of burner

REFRIGERATOR	FREEZER	UNITS
24	—	litres
70	—	litres
83 x 82 x 98 —		cm.
Aladdin 32		

PERFORMANCE AT

Icepack freezing, with vaccine
Icepack freezing, without vaccine
Holdover time during power cut
Power consumption: electricity
Power consumption: kerosene

32	43	32	43	degrees C°
—	—	2.4/24	—	kg/hrs.
—	—	—	—	kg/hrs.
6.5	0.5	++	++	hours
++	++	—	—	kWh/24 hrs
0.77	0.8	—	—	kg/24 hrs.

ENERGY REQUIREMENTS

Energy sources: 230 V + 110V + Kerosene

SPARES NEEDED PER 10 UNITS

	Part No.	Qty	Price/unit		
Wick 32	292.8551.06	3	XEU	3.19	(US\$ 2.90)
Electrical Heater 230 V	296.9730.02	1	XEU	7.35	(US\$ 6.68)
Thermostat	292.2007.04	1	XEU	4.32	(US\$ 3.93)
Glass Flue	292.8551.02	2	XEU	24.70	(US\$ 22.45)
Burner	292.8550.02	2	XEU	65.27	(US\$ 59.34)

COMMENTS AND ACCESSORIES

Reports: GET (1999), Meets WHO/UNICEF Standard: E3/RF.2.

The appliance is supplied with two kinds of walls for separation between the freezing and cooling compartment: aluminum sheets for lower ambient temperatures and water containers for higher ambient temperatures.

The Freezing compartment freezes and stores 4 x 0.6 litre icepacks.

Warning: Temperatures near the evaporator of the refrigerating compartment are liable to fall below zero; this area is therefore not suitable for the storage of DPT, DT, TT and Hepatitis B vaccine.

2000 PRICES (FOT Luxembourg)

Shipping volume / weight 0.73 m³ / 76 kg

Quantity/Price:	1-39:	XEU	1 395.00	(US\$	1 268.18)
	40-99:	XEU	1 325.00	(US\$	1 204.55)
	100+:	XEU	1 259.00	(US\$	1 144.55)

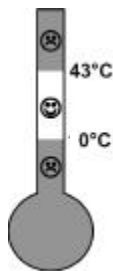

CODE PIS E3/92-M
Hot zone appliance

Photovoltaic solar refrigerator and icepack freezer: Model 120-30

COMPANY NAME AND ADDRESS

Norcoast Refrigeration Co.
50 Grigor Street
Caloundra, QLD 4551
Australia
Telephone: 61 (7) 94 91 18 49
Fax: 61 (7) 54 91 76 27

SPECIFICATIONS

Vaccine storage capacity
Manufacturers gross volume
External dimensions, H x W x L

REFRIGERATOR	FREEZER	UNITS
63	—	litres
120	30	litres
86x124x76	—	cm

PERFORMANCE AT

Icepack freezing, with vaccine
Icepack freezing, without vaccine
Holdover time during power cut

32	43	32	43	degrees C°
—	—	3.6/20	2.4/18	kg/hrs.
—	—	++	++	kg/hrs.
3.5	2.3	—	—	hours

Electricity consumption:

With icepack freezing	—	—	0.85*	0.97*	kWh/24 hrs
Without icepack freezing	0.59*	0.97*	—	—	kWh/24 hrs

ENERGY REQUIREMENTS

Energy sources: 12VDC

SPARES NEEDED PER 10 UNITS

	Part No.	Qty	Price / unit
Compressor, Danfoss	BD50F	1	US\$ 220.00
Controller, Danfoss	101NO210	1	US\$ 220.00
Lid seal	LS 120/30	1	US\$ 25.00

COMMENTS AND ACCESSORIES

Reports: R&TC, A.14213 (March 1999). Meets WHO/UNICEF Standard: E3/RF.4.

Suitable for freezing icepacks at low ambient temperatures.

Freezer compartment should be used for icepacks only; it is not suitable for storage or freezing of vaccines. It can contain 8 frozen icepacks of 0.6 litres.

Accessories: external freezer and refrigerator temperature indicator; low battery indicator; defrost switch; battery condition meter; all connecting cables and installation instructions.

2000 PRICES (EX-WORKS Australia)

Shipping volume/gross weight 1.11 m³ / 115 kg

Quantity/Price: Cabinet only 1/US\$ 2600.00

* Measured with both the freezer and the refrigerator compressor turned on.

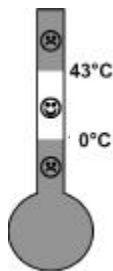

CODE PIS E3/93-M
Hot zone appliance

Photovoltaic solar refrigerator & icepack freezer, compression RCW 50DC/CF(Blue)

COMPANY NAME AND ADDRESS

Electrolux (Luxembourg) SARL
14, op der Hei
L-9809 Hosingen
Luxembourg
Telephone: 352 920 731
Fax: 352 920 731 300
E-mail: Pascal.Vannier@notes.electrolux.lu

SPECIFICATIONS

Vaccine storage capacity
Frozen icepack storage capacity
Manufacturers gross volume
External dimensions, H x W x L

REFRIGERATOR	FREEZER	UNITS
24	—	litres
—	8	0.6 litres
70	9	litres
83x72x98	—	cm.

PERFORMANCE AT

Icepack freezing, with vaccine
Icepack freezing, without vaccine
Holdover time during power cut
Electricity consumption:

With icepack freezing
Without icepack freezing

32	43	32	43	degrees C°
—	—	2.4/10*	2.4/11.5*	kg/hrs.
—	—	++	++	kg/hrs.
9	5	++	++	hours
++	++	1.01	1.39	kWh/24 hrs
0.64	1.08	++	++	kWh/24 hrs

ENERGY REQUIREMENTS

Energy sources: 12V to 24V

SPARES NEEDED PER 10 UNITS

	Part No.	Qty	Price/unit	
Thermostat for electric refrigerator	292.2007.09	3	XEU 7.69	(US\$ 6.99)
Electronic	296.9705.13	3	XEU 129.28	(US\$ 117.53)
Compressor 12 to 24 VDC	296.9702.08	1	XEU 193.36	(US\$ 175.78)
Fan	296.9710.10	1	XEU 9.89	(US\$ 8.99)

COMMENTS AND ACCESSORIES

Reports: GET, September 1999; Meets WHO/UNICEF Standard: E3/RF.4.

Energy consumption of this appliance is above the level given in the Performance Specifications for E3/RF.4 (1.08 kWh/24hrs is required as opposed to 0.9 kWh/24hrs in the spec). If the panels, batteries and other components of the system are different from the ones supplied by the manufacturer, it is crucial to ensure their capacity is adequate for the energy requirement of the cabinet.

2000 PRICES (FOT Luxembourg)

Shipping volume/gross weight 0.73 m³ / 78 kg.

Quantity/price**:	1-39:	XEU 1 395	(US\$ 1 268.18)
	40-99:	XEU 1 324	(US\$ 1 203.64)
	100+:	XEU 1 258	(US\$ 1 143.64)

Complete solar system Consult manufacturer

* Freezing and freezer storage compartment can both contain 4 icepacks of 0.6 liter. The appliance can safely freeze 4.8 kg within 24 hours, while maintaining the vaccines at the correct temperature, by rotating frozen icepacks between both compartments.

** Cost of export packing for sea freight not included in price (allow approximately XEU 49.00 (US\$44.54) per appliance.



CODE PIS E3/94 -M
Hot zone appliance

**Refrigerator and icepack freezer,
compression: RCW 50 AC (Blue)**

COMPANY NAME AND ADDRESS

Electrolux (Luxembourg) SARL
14, op der Hei
L-9809 Hosingen
Luxembourg
Telephone: 352 920 731
Fax: 352 920 731 300
E-mail: Pascal.Vannier@notes.electrolux.lu

SPECIFICATIONS

Vaccine storage capacity
Frozen icepack storage capacity
Manufacturers gross volume
External dimensions, H x W x L

	REFRIGERATOR	FREEZER	UNITS
Vaccine storage capacity	24	—	litres
Frozen icepack storage capacity	—	8*	0.6 litres
Manufacturers gross volume	70	9	litres
External dimensions, H x W x L	83 x 98 x 72	—	cm.

PERFORMANCE AT

Icepack freezing, with vaccine
Icepack freezing, without vaccine
Holdover time during power cut
Electricity consumption:

	32	43	32	43	degrees C°
Icepack freezing, with vaccine	—	—	2.4/14.5	4.8/29	kg/hrs.
Icepack freezing, without vaccine	—	—	—	—	kg/hrs.
Holdover time during power cut	16	8	++	++	hours
Electricity consumption:					
With icepack freezing	—	—	1.64	2.02	kWh/24 hrs
Without icepack freezing	0.9	1.69	—	—	kWh/24 hrs

ENERGY REQUIREMENTS

Energy sources: 230 V / 50 Hz AC and 110V/60Hz
Minimum starting voltage 175 V

SPARES NEEDED PER 10 UNITS

	Part No.	Qty	Price/unit	
Thermostat for electric refrigerator	292.2007.09	3	XEU 7.69	(US\$ 6.99)
Compressor TLS3FT HST	296.9701.12	1	XEU 272.19	(US\$ 247.45)
Fan outside	296.9759.03	1	XEU 18.33	(US\$ 16.66)
Fan inside	296.9710.10	1	XEU 9.86	(US\$ 8.96)

COMMENTS AND ACCESSORIES

Reports: GET (January 2000), Meets WHO/UNICEF Standard: E3/RF1

This appliance is supplied with two water filled walls to separate the freezing and refrigeration compartment.

*The freezing compartment is divided into two areas: a freezing compartment for 4 x 0.6 litre icepacks and a freezer storage compartment for a further 4x 0.6 litre icepacks.

Removable partition between freezing and refrigerator compartments also provided.

2000 PRICES (FOT Luxembourg)

Shipping volume / weight 0.73 m³ / 76 kg

Quantity/Price:					
1-39:	XEU	1 289	(US\$	1 171.82)	
40-99:	XEU	1 225	(US\$	1 113.64)	
100+:	XEU	1 161	(US\$	1 055.45)	

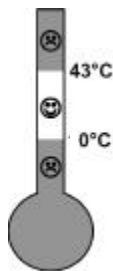

CODE PIS E3/95-M
Hot zone appliance

Ice pack freezer, absorption type
Model PF 230 IP Kerosene and Electric

COMPANY NAME AND ADDRESS

Zero Appliances
P.O. Box 426, Edenvale 1610
Kempton Park, Gauteng
South Africa
Telephone: 27 (11) 393 41 40
Fax: 27 (11) 393 4 119
E-mail: zero@elink.co.za

SPECIFICATIONS

Frozen icepack storage capacity
Manufacturers gross volume
External dimensions, H x W x L
Burner Type

REFRIGERATOR	FREEZER	UNITS
—	144	litres
—	230	litres
—	93x70x134	cm
—	Aladdin 32	

PERFORMANCE AT

Icepack freezing, with vaccine
Icepack freezing, without vaccine
Holdover time during power cut
Power consumption: electricity
Power consumption: kerosene

32	43	32	43	degrees C°
—	—	—	—	kg/hrs.
—	—	4.8/24	1.8/8	kg/hrs.
—	—	++	++	hours
—	—	++	++	kWh/24 hrs
—	—	0.93	++	lts/24 hrs.

ENERGY REQUIREMENTS

Energy sources: Kerosene or 220VAC/50Hz; other voltages on request.
Model can also run on LP Gas. Conversion kits available on request

SPARES NEEDED PER 10 UNITS	Part No.	Qty	Price/unit
Wick	SU230P20	10	US\$ 6.40
Metal flue with window	SU230P16	1	US\$ 24.00
Door gasket/seal	PL265GA05	1	US\$ 9.00
External thermometer	IMP55	1	US\$ 16.00
Electric thermostat	IMP32	2	US\$ 11.40
Electric heater (220V)	ELEM25	2	US\$ 13.50
Flame spreader	ZP990211	2	US\$ 3.75
Flue baffle	BF65	2	US\$ 4.50
Flue brush	70GBAFFLE	2	US\$ 2.50

COMMENTS AND ACCESSORIES

Reports: CSIR, ESH2000-0028 (2000); Meets WHO/UNICEF Standard: E3/RF4

Accessories: Lockable lid, 5 wicks, 1 Flue, 3 flame spreaders, 5 wick cleaners, 1 Flue brush, 1 funnel. Packed in a seaworthy case/crate.

2000 PRICES (Ex Works Chloorkop, Kempton Park, South Africa)

Shipping volume/gross weight(crated) 1.40 m³ / 135 kg

Quantity/Price:	1-39	US\$ 906.00
	40-99	US\$ 860.00
	100+	US\$ 816.00

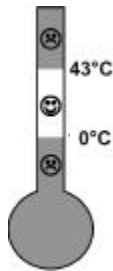
**CODE PIS E3/96-M****Hot zone appliance**

**Vaccine/icepack chest freezer,
compression: Model MF 114 (New Generation)**

COMPANY NAME AND ADDRESS

Vestfrost A/S
P. O. Box 2079
Spangsbjerg Mollevej 100
DK 6705 Esbjerg 0, Denmark
Telephone: 45 (79) 14 22 22
Fax: 45 (79) 14 23 55
E-mail: export@vestfrost.dk

SPECIFICATIONS

Vaccine storage capacity
Manufacturers gross volume
External dimensions, H x W x L
The cooling refrigerant is R134A

REFRIGERATOR	FREEZER	UNITS
—	72	litres
—	111	litres
—	85x60x72	cm.
—	—	—

PERFORMANCE AT

	32	43	32	43	degrees C°
Icepack freezing, with vaccine	—	—	—	37.2/51	kg/hrs.
Icepack freezing, without vaccine	—	—	—	17.5/24	kg/hrs.
Holdover time during power cut	—	—	—	13	hours
Power consumption: electricity	—	—	—	1.58	kWh/24 hrs
Thermostat setting: Continuous energy	—	—	—	6	

ENERGY REQUIREMENTS

Energy sources: 220 VAC/50 Hz
Available in various voltages: 115, 240 VAC, 50 or 60 Hz.
Minimum of 8 hours electricity needed per 24 hours at 43°C°
Voltage stabilizer recommended where power supply is intermittent.

SPARES NEEDED PER 10 UNITS	Part No.	Qty	Price / unit
Compressor, Danfoss FR8.5G OC	03.603326	1	XEU 80.20 (US\$ 72.91)
Starting device (Relay)	02.7038050	1	XEU 7.20 (US\$ 6.55)
Starting device (Capacitor)	6520004	1	XEU 12.48 (US\$ 11.35)
Thermostat	02.7038480	1	XEU 7.38 (US\$ 6.71)
Thermometer	02.7020037-01	1	XEU 7.83 (US\$ 7.12)
Filter/drier type XH 9 (20 grs)	02.6538053	1	XEU 2.83 (US\$ 2.57)
Alu-cylinder with R134A (1000 grs)	04.9954073	1	XEU 28.80 (US\$ 26.18)

COMMENTS AND ACCESSORIES

Reports: Bureau Veritas T99124 (2000) Meets WHO/UNICEF Standard:E3/RF.1.
Appliance equipped with HST compressor.
Accessories: external electronic temperature reading, locking lid.

2000 PRICES (FCA Esbjerg)

Shipping volume/gross weight 0.58 m³ / 55 kg.

Quantity/Price: XEU 312.00 (US\$ 283.64)

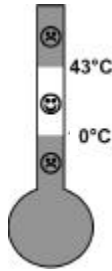

CODE PIS E3/97-M
Hot zone appliance

**Vaccine/icepack chest freezer,
compression: Model MF 214 (New Generation)**

COMPANY NAME AND ADDRESS

Vestfrost A/S
P. O. Box 2079
Spangsbjerg Mollevej 100
DK 6705 Esbjerg 0, Denmark
Telephone: 45 (79) 14 22 22
Fax: 45 (79) 14 23 55
E-mail: export@vestfrost.dk

SPECIFICATIONS

Vaccine storage capacity
Manufacturers gross volume
External dimensions, H x W x L
The cooling refrigerant is R134A

REFRIGERATOR	FREEZER	UNITS
—	192	litres
—	213	litres
—	85x60x113	cm.
—	—	—

PERFORMANCE AT

	32	43	32	43	degrees C°
Icepack freezing, with vaccine	—	—	—	70.8/76	kg/hrs.
Icepack freezing, without vaccine	—	—	—	22.86/24	kg/hrs.
Holdover time during power cut	—	—	—	15.5	hours
Power consumption: electricity	—	—	—	1.93	kWh/24 hrs
Thermostat setting: Continuous energy	—	—	—	3	

ENERGY REQUIREMENTS

Energy sources: 220 VAC/50 Hz
Available in various voltages: 115, 240 VAC, 50 or 60 Hz.
Voltage stabilizer recommended where power supply is intermittent.

SPARES NEEDED PER 10 UNITS

	Part No.	Qty	Price / unit		
Compressor, Danfoss FR8.5G OC	03.603326	1	XEU	80.20	(US\$ 72.91)
Starting device (Relay)	02.7038050	1	XEU	7.20	(US\$ 6.55)
Starting device (Capacitor)	6520004	1	XEU	12.48	(US\$ 11.35)
Thermostat	02.7038480	1	XEU	7.38	(US\$ 6.71)
Thermometer	02.7020037-01	1	XEU	7.83	(US\$ 7.12)
Filter/drier type XH 9 (20 grs)	02.6538053	1	XEU	2.83	(US\$ 2.57)
Alu-cylinder with R134A (1000 grs)	04.9954073	1	XEU	28.80	(US\$ 26.18)
Basket for freezing icepacks	02.3010195	1	XEU	12.10	(US\$ 11.00)

COMMENTS AND ACCESSORIES

Reports: Bureau Veritas T99119(2000) Meets WHO/UNICEF Standard:E3/FR.1.

Appliance equipped with HST compressor.

Accessories: external electronic temperature reading, locking lid.

2000 PRICES (FCA Esbjerg)

Shipping volume/gross weight 0.88 m³ / 82 kg.

Quantity/Price: XEU 353.00 (US\$ 320.91)

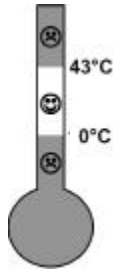

CODE PIS E3/98-M
Hot zone appliance

Vaccine/icepack chest freezer,
compression: Model MF 314 (New Generation)

COMPANY NAME AND ADDRESS

Vestfrost A/S
P. O. Box 2079
Spangsbjerg Mollevej 100
DK 6705 Esbjerg 0, Denmark
Telephone: 45 (79) 14 22 22
Fax: 45 (79) 14 23 55
E-mail: export@vestfrost.dk

SPECIFICATIONS

Vaccine storage capacity
Manufacturers gross volume
External dimensions, H x W x L
The cooling refrigerant is R134A

REFRIGERATOR	FREEZER	UNITS
—	264	litres
—	323	litres
—	85x60x156	cm.
—	—	—

PERFORMANCE AT

	32	43	32	43	degrees C°
Icepack freezing, with vaccine	—	—	—	108/80	kg/hrs.
Icepack freezing, without vaccine	—	—	—	32.4/24	kg/hrs.
Holdover time during power cut	—	—	—	17.5	hours
Power consumption: electricity	—	—	—	2.71	kWh/24 hrs
Thermostat setting: Continuous energy	—	—	—	3.5	

ENERGY REQUIREMENTS

Energy sources: 220 VAC/50 Hz
Available in various voltages: 115, 240 VAC, 50 or 60 Hz.
Voltage stabilizer recommended where power supply is intermittent.

SPARES NEEDED PER 10 UNITS	Part No.	Qty	Price / unit		
Compressor, Danfoss FR10.G OC	03.603326	1	XEU	80.20	(US\$ 72.91)
Starting device (Relay)	02.7038050	1	XEU	7.20	(US\$ 6.55)
Starting device (Capacitor)	6520004	1	XEU	12.48	(US\$ 11.35)
Thermostat	02.7038480	1	XEU	7.38	(US\$ 6.71)
Thermometer	02.7020037-01	1	XEU	7.83	(US\$ 7.12)
Filter/drier type XH 9 (20 grs)	02.6538053	1	XEU	2.83	(US\$ 2.57)
Alu-cylinder with R134A (1000 grs)	04.9954073	1	XEU	28.80	(US\$ 26.18)
Basket for freezing icepacks	02.3010195	1	XEU	12.10	(US\$ 11.00)

COMMENTS AND ACCESSORIES

Reports: Bureau Veritas T99120 (2000) Meets WHO/UNICEF Standard:E3/FR..1.

Appliance equipped with HST compressor.

Accessories: external electronic temperature reading, locking lid.

2000 PRICES (FCA Esbjerg)

Shipping volume/gross weight 0.98 m³ / 95 kg.

Quantity/Price: XEU 404.00 (US\$ 367.27)

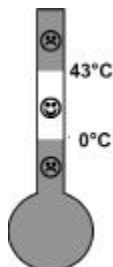

CODE PIS E3/99 -M
Hot zone appliance

**Vaccine/icepack chest freezer,
compression: FCW 300**

COMPANY NAME AND ADDRESS

Electrolux (Luxembourg) SARL
14, op der Hei
L-9809 Hosingen
Luxembourg
Telephone: 352 920 731
Fax: 352 920 731 300
E-mail: Pascal.Vannier@notes.electrolux.lu

SPECIFICATIONS

Vaccine storage capacity
Frozen icepack storage capacity
Manufacturers gross volume
External dimensions, H x W x L

REFRIGERATOR	FREEZER	UNITS
—	264	litres
—	—	0.6 litres
—	300	litres
—	86x160x70	cm.

PERFORMANCE AT

Icepack freezing, with vaccine
Icepack freezing, without vaccine
Holdover time during power cut
Electricity consumption:

	32	43	43	degrees C°
Icepack freezing, with vaccine	—	—	7.2/24	kg/hrs.
Icepack freezing, without vaccine	—	—	22.8/24	kg/hrs.
Holdover time during power cut	—	—	15	hours
Electricity consumption:				
With icepack freezing	—	—	2.98	kWh/24 hrs
Without icepack freezing	—	—	—	kWh/24 hrs

ENERGY REQUIREMENTS

Energy sources: 230 V / 50 Hz AC
Minimum starting voltage 179.4 V

SPARES NEEDED PER 10 UNITS

	Part No.	Qty	Price/unit		
Thermostat for electric refrigerator	291.2477.00	3	XEU	10.14	(US\$ 6.99)
Compressor, Danfoss FR 10G	210.0272.00	1	XEU	243.06	(US\$ 247.45)
Capacitor for compressor	291.2146.00	1	XEU	37.50	(US\$ 16.66)
Starting device	291.2087.06	3	XEU	18.33	(US\$ 8.96)

COMMENTS AND ACCESSORIES

Reports: GET (July 2000), Meets WHO/UNICEF Standard: E3/RF1

2000 PRICES (FOT Luxembourg)

Shipping volume / weight 1.3 m³ / 98 kg

Quantity/Price:		XEU		(US\$	
1-39:	XEU	821	(US\$	1 171.82)	
40-99:	XEU	781	(US\$	1 113.64)	
100+:	XEU	744	(US\$	1 055.45)	

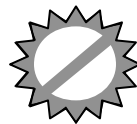
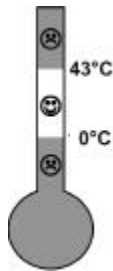
**CODE PIS E3/100 -M****Hot zone appliance****Vaccine/icepack chest freezer,
compression: FCW 200****COMPANY NAME AND ADDRESS**

Electrolux (Luxembourg) SARL

14, op der Hei

L-9809 Hosingen

Luxembourg

Telephone: 352 920 731

Fax: 352 920 731 300

E-mail: Pascal.Vannier@notes.electrolux.lu

SPECIFICATIONS

Vaccine storage capacity
Frozen icepack storage capacity
Manufacturers gross volume
External dimensions, H x W x L

REFRIGERATOR	FREEZER	UNITS
—	144	litres
—	—	0.6 litres
—	180	litres
—	86x106x70	cm.

PERFORMANCE AT

Icepack freezing, with vaccine
Icepack freezing, without vaccine
Holdover time during power cut
Electricity consumption:

	32	43	43	degrees C°
Icepack freezing, with vaccine	—	—	7.2/24	kg/hrs.
Icepack freezing, without vaccine	—	—	13.2/24	kg/hrs.
Holdover time during power cut	—	—	14	hours
Electricity consumption:				
With icepack freezing	—	—	—	kWh/24 hrs
Without icepack freezing	—	—	1.44	kWh/24 hrs

ENERGY REQUIREMENTS

Energy sources:

230 V / 50 Hz AC

Minimum starting voltage 175 V

SPARES NEEDED PER 10 UNITS

	Part No.	Qty	Price/unit		
Thermostat for electric refrigerator	291.2477.00	3	XEU	10.14	(US\$ 6.99)
Compressor, Danfoss FR 10G	210.0271.00	1	XEU	237.50	(US\$ 247.45)
Capacitor for compressor	201.4555.66	1	XEU	47.08	(US\$ 16.66)
Starting device	291.2087.05	3	XEU	13.33	(US\$ 8.96)

COMMENTS AND ACCESSORIES

Reports: GET (March 2000), Meets WHO/UNICEF Standard: E3/RF1

2000 PRICES (FOT Luxembourg)Shipping volume / weight 0.87 m³ / 86 kg

Quantity/Price:		XEU		(US\$	
1-39:	XEU	665	(US\$	1 171.82)	
40-99:	XEU	634	(US\$	1 113.64)	
100+:	XEU	603	(US\$	1 055.45)	

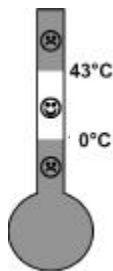

CODE PIS E3/101 -M
Hot zone appliance

Photovoltaic solar refrigerator & icepack freezer, compression PVR150

COMPANY NAME AND ADDRESS

Solamatics (Pvt) Ltd
31 Edison Crescent
Graniteside, Harare
Zimbabwe
Telephone: 263 (4) 74 99 30
Fax: 263 (4) 77 12 12
E-mail: solamatics@mcdiarmid.co.zw

SPECIFICATIONS

Vaccine storage capacity
Frozen icepack storage capacity
Manufacturers gross volume
External dimensions, H x W x L

REFRIGERATOR	FREEZER	UNITS
30	—	litres
—	12	0.6 litres
105	38	litres
90x69x73	—	cm.

PERFORMANCE AT

Icepack freezing, with vaccine
Icepack freezing, without vaccine
Holdover time during power cut
Electricity consumption:

	32	43	32	43	degrees C°
Icepack freezing, with vaccine	—	—	3.6/24	3.6/16	kg/hrs.
Icepack freezing, without vaccine	—	—	++	++	kg/hrs.
Holdover time during power cut	5.5	5.5	++	++	hours
Electricity consumption:					
With icepack freezing	0.57	0.98	++	++	kWh/24 hrs
Without icepack freezing	0.42	0.73	++	++	kWh/24 hrs

ENERGY REQUIREMENTS

Energy sources: 12V to 24V

SPARES NEEDED PER 10 UNITS

	Part No.	Qty	Price/unit
Thermview electronic thermostat		1	(US\$ 255.00)
Compressor, Danfoss BD 35 F with controller		1	(US\$ 395.00)

COMMENTS AND ACCESSORIES

Reports: GET (March 2000), Meets WHO/UNICEF Standard: E3/RF1

2000 PRICES (FOT Luxembourg)

Shipping volume / weight 0.9 m³ / 90 kg

Quantity/Price:	1-39:	(US\$ 2 000.00)
	40-99:	(US\$ 1 875.00)

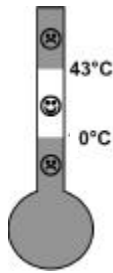

CODE PIS E3/102-M
Hot zone appliance

**Refrigerator and ice pack freezer,
absorption, Model GR265 Kerosene/Electric**

COMPANY NAME AND ADDRESS

Zero Appliances
P.O. Box 426, Edenvale 1610
Kempton Park, Gauteng
South Africa
Telephone: 27 (11) 393 41 40
Fax: 27 (11) 393 4 119
E-mail: zero@elink.co.za

SPECIFICATIONS

Frozen icepack storage capacity
Manufacturers gross volume
External dimensions, H x W x L
Burner Type

	REFRIGERATOR	FREEZER	UNITS
Frozen icepack storage capacity	—	16	litres
Manufacturers gross volume	—	215	litres
External dimensions, H x W x L	—	153x60x68	cm
Burner Type	—	Jet 13	

PERFORMANCE AT

Icepack freezing, with vaccine
Icepack freezing, without vaccine
Holdover time during power cut
Power consumption: electricity
Power consumption: Gas

	32	43	32	43	degrees C°
Icepack freezing, with vaccine	—	—	4.2/24	1.8/24	kg/hrs.
Icepack freezing, without vaccine	—	—	—	—	kg/hrs.
Holdover time during power cut	3.5	1.5	++	++	hours
Power consumption: electricity	6	8	++	++	kWh/24 hrs
Power consumption: Gas	0.66	0.77	0.93	++	lts/24 hrs.

ENERGY REQUIREMENTS

Energy sources: LP Gas or 220VAC/50Hz; other voltages on request.

SPARES NEEDED PER 10 UNITS	Part No.	Qty	Price/unit
Door gasket/fridge seal	PL265GA05	1	US\$ 8.30
Door gasket/freezer seal	PL265GA10	1	US\$ 4.60
External thermometer	IMP55	1	US\$ 16.00
Thermocouple	IMP10	2	US\$ 13.50
Burner Jet 13	JFGE26	2	US\$ 1.30
Gas ignitor	IMP20	1	US\$ 2.50
Thermostat (Gas/Elec)	IMP33	2	US\$ 53.00
Chimney Baffle	70BAFFLE	1	US\$ 3.80
Electric heater (220V)	ELEM23	2	US\$ 13.50

COMMENTS AND ACCESSORIES

Reports: CSIR, ESH2000-0025 (2000); Meets WHO/UNICEF Standard: E3/RF.2

Accessories: Lockable door, external thermometer, Flame indicator, adjustable leveling feet, gas Safety Valve, silent operation, Rush Button Lighting device, Instruction Manual, other spares available on request.

2000 PRICES (Ex Works Chloorkop, Kempton Park, South Africa)

Shipping volume/gross weight(crated) 1.036 m³ / 94 kg

Quantity/Price:		US\$
1-20		846.00
21-50		815.00
100+		759.00
100+		738.00
100+		729.00

Section E4

Cold boxes and vaccine carriers

1. Choosing a cold box or vaccine carrier

Points to consider (see the glossary for definitions)

1) **Vaccine storage capacity:** How much vaccine will be carried?

To calculate the quantity of vaccine that must be transported, see the information given on vaccine storage volumes (General information, 1.2).

2) **Cold life:** How long must vaccine be stored? (Consider local temperatures and add a generous safety margin.)

The data for cold life “without openings” on the sheets in this section are an assessment of the longest time the vaccine can be stored in a cold box or vaccine carrier with the lid closed. Cold life has been measured at an ambient temperature of +43°C to allow for increased temperatures inside vehicles. It is recommended to double estimated requirements to allow openings of the cold box, plus delays in transportation. For example; if it is calculated that the proposed activity requires 24 hours cold life, double that calculation, and ensure the equipment has 48 hours cold life.

Data for cold life “with openings” are no longer included.

3) **Weight:** How will the cold box be carried?

Weight fully loaded and durability can be graded according to how the box will be transported (by vehicle, horse, bicycle or hand carried) and how roughly it will be treated. For example, durability will be more important than weight for a box transported by vehicle over rough roads so it should have a good rating in the drop test. The reverse will apply to hand-carried boxes where weight will be more important.

4) **Durability:** To what conditions will the cold box be exposed?

Soft carriers: The durability of vaccine carriers is only partly represented by the measure of “robustness” obtained during laboratory drop tests. Vaccine carriers are either constructed with a hard plastic exterior or with a soft canvas/PVC bag around the insulated walls. Experience in an increasing number of countries has shown that the soft, canvas type carriers do not last long. They are liable to tear and the catches and straps tend to break away. A warning about their short working life is included in the sheets.

5) **Icepacks:** Are icepacks included?

At the time of placing an order it is important to check if icepacks are included with the box or not. If they are not included, select icepacks that will fit the chosen box and simultaneously place an order for them. Each sheet specifies how many icepacks (one set) are required for the box or carrier. When ordering always order two sets of icepacks: one set to be used while the other is being frozen.

6) **Shipping:** Remember to consider shipping costs! It is important to note here that the prices on the sheets do **not** include shipping costs. Insulated boxes are bulky and therefore shipping costs can often represent a high proportion of the total cost. Shipping costs must be investigated before programme managers make a final purchase choice.

7) **Cost:** Which cold box (with icepacks) meets requirements 1, 2, 3 and 4 for lowest cost? Choose the cold box that fulfills programme requirements at the least cost. Don’t forget to calculate the cost of shipping!

2. Criteria for the classification of cold boxes and vaccine carriers

Table 1: Capacity of various types of vaccine carrier

Terminology used in the PIS	Vaccine storage capacity (litres)	Cold life (hours)
Vaccine carrier for NID	0.1–3.0	≥ 8 hr
Small vaccine carrier	0.1–1.0	≥ 16 hr
Large vaccine carrier	0.1–4.0	≥ 24 hr
Small cold box, long range	4.0 – 15.0	≥ 90 hr
Large cold box, long range	≥ 15.0	≥ 120 hr
Small cold box, short range	4.0 – 15.0	≥ 48 hr
Large cold box, short range	≥ 15.0	≥ 48 hr

Table 2: Cold boxes and vaccine carriers grouped on basis of cold life and vaccine storage capacity

Capacity (litres)	Cold life in hours, at +43°C ambient temperature				
	< 24 hours	24–48 hours	49–72 hours	73–120 hours	>121 hours
> 25.1					
15.1–25				E4/09	E4/05-M; 37-M; 72-M; 76-M
4.1–15			E4/57-M; 80-M; 85-M, 86-M, 87-M	E4/10; 22; 62-M; 75-M; 78-M; 88-M	
1.1–4	E4/84-M	E4/18-M; 19; 34; 42; 52-M; 67-M; 71; 77-M; 83-M	E4/81-M	E4/20	
0.1–1	E4/53-M; 55-M; 63; 68-M; 69-M	E4/79			

3. Keeping vaccines cool during immunization sessions

Foam pads, first listed as a new accessory for some vaccine carriers in the 1997 edition, remain in the 2000 edition. The foam pad serves as a temporary lid to keep vaccines inside the carrier cool while at the same time providing a surface to hold and protect vaccine vials during immunization sessions. It is a simple piece of soft foam, minimum 30 mm thickness, which fits tightly inside the "neck" of the carrier on top of the icepacks, under the existing lid.

It is not recommended to keep a vial in the hole of the icepack on a table during the session. This practice has shown to result in significant loss of potency.

4. Vaccine packaging for international transport of vaccine¹

Vaccine packaging is no longer listed in the present edition of the Product Information Sheets, because the vaccine manufacturer often supplies it, and boxes change frequently and may be manufactured on request by the client.

Class A: Freeze-dried measles, yellow fever and liquid oral poliomyelitis vaccine shall be packed to ensure that the warmest storage temperature of the vaccine does not rise above +8°C in continuous outside ambient temperatures of +43°C for a period of at least 48 hours. The diluent for freeze-dried measles vaccine need not be subject to the same packaging but should travel with the vaccine consignment whenever feasible. One cold chain monitor card should be packed with each 3000 doses of vaccine.

Class B: BCG, adsorbed DPT and Hepatitis B vaccines shall be packed to assure that the warmest storage temperature of the vaccine does not rise above +30°C in continuous outside ambient temperatures of +43°C for a period of at least 48 hours. The diluent for BCG vaccine need not be cooled but should travel with the vaccine whenever feasible. One cold chain monitoring card should be packed with each 3000 doses of vaccine.

Class C: DT and tetanus vaccine need not be packed in insulated cartons with icepacks for international air transport. One chemical temperature threshold indicator should be packed with each 3000 doses of vaccine.

¹ As defined in document EPI/CCIS/81.04 Rev.5.

CODE**PIS****E4/05-M****Large vaccine cold box, long range:
Model RCW 25/CF(Blue) (991.1537.01)****COMPANY NAME AND ADDRESS**

Electrolux (Luxembourg) SARL
14, op der Hei
L-9809 Hosingen
Luxembourg
Telephone: 352 920 731
Fax: 352 920 731 300
e-mail: Pascal.Vannier@notes.electrolux.lu

SPECIFICATIONS

Vaccine storage capacity	20.70 litres
Weight fully loaded	(32.80) kg.
Weight empty	(17.0) kg.
External surface material	Polyethylene
Internal lining material	Polyethylene
Insulation material	Polyurethane foamed with cyclopentane
Insulation thickness	105 mm.
External dimensions	71x55x50 cm.
Internal dimensions	50x34x27 cm.
Vaccine storage dimensions	42x26x19 cm.
Lid type & fixings	Hinged
Number of icepacks required	24
Number of icepacks supplied	24
Icepack type	E5/09, 16, 18
Robustness in drop test:	Fittings 2; casing 5
Cold life without openings	(181) hrs. at +32°C 129.9 hrs. at +43°C

COMMENTS

Test report: GET 50361-3300 WI/BO (1995),
Electrolux (1995)

Meets WHO/UNICEF Standard E4/CB2

From 1998 this item will be colored in blue, as
opposed to yellow previously.

2000 PRICES (FOT Luxembourg)

Shipping weight/volume 0.29 m3/48.3 kg
Minimum order 1

Quantity	Price/unit
1-39:	XEU 449.00 (US\$ 408.18)
40-99:	XEU 427.00 (US\$ 388.18)
100+ :	XEU 405.00 (US\$ 368.18)

CODE**PIS****E4/09***With**CFC***Large vaccine cold box, short range:
Model CB/INO/B3/90****COMPANY NAME AND ADDRESS**

Ina ColdMed (formerly Hinardi Djajahardja)
Jl. Klingkit 3 No 86
Kompl. Bojong Indah
Jakarta 11740
Indonesia
Tel. / Fax: 62 (21) 581 1531

SPECIFICATIONS

Vaccine storage capacity	16.2 litres
Weight fully loaded	31.8 kg.
Weight empty	16.3 kg.
External surface material	Fibreglass
Internal lining material	Fibreglass
Insulation material	Polyurethane
Insulation thickness	105 mm.
External dimensions	54x54x57 cm.
Internal dimensions	33x33x34 cm.
Vaccine storage dimensions	25x25x26 cm.
Lid type & fixings	Hinged
Number of icepacks required	29x0.4 l
Number of icepacks supplied	0
Icepack type	E5/IP.2
Robustness in drop test:	Fittings 2; Casing 3
Cold life without openings	+ hrs. at +32°C 107 hrs. at +43°C

COMMENTS

Test Reports: CRL.Z.9423 ; AIT/EP/91-4 (1991)
Meets WHO/UNICEF Standard E4/CB.3

2000 PRICES (EX WORKS)

Shipping weight/volume 30 kg / 0.30 m3
Minimum order 20

Quantity/Price: 1/US\$ 296.00

CODE**PIS****E4/10***With**CFC***Small vaccine cold box, short range:
Model CB/INO/C2/90****COMPANY NAME AND ADDRESS**

Ina ColdMed (formerly Hinardi Djajahardja)
 Jl. Klingkit 3 No 86
 Kompl. Bojong Indah
 Jakarta 11740
 Indonesia
 Tel. / Fax: 62 (21) 581 1531

SPECIFICATIONS

Vaccine storage capacity	6.5 litres
Weight fully loaded	20.6 kg.
Weight empty	12.5 kg.
External surface material	Fibreglass
Internal lining material	Fibreglass
Insulation material	Polyurethane
Insulation thickness	105 mm.
External dimensions	47x47x50 cm.
Internal dimensions	26x26x28 cm.
Vaccine storage dimensions	18x18x20 cm.
Lid type & fixings	Hinged
Number of icepacks required	6x0.6l+8x0.4l
Number of icepacks supplied	0
Icepack type	E5/IP.1,2
Robustness in drop test:	Fittings 2; Casing 4
Cold life without openings	+ hrs. at +32°C 81 hrs. at +43°C

COMMENTS

Test Reports: CATR.Z.9423 (1979); AIT/EP/91-4 (1991)

Meets WHO/UNICEF Standard E4/CB.4

2000 PRICES (EX WORKS)

Shipping weight/volume 37 kg / 0.27 m³
Minimum order 20

Quantity/Price: 1/US\$ 190.00

CODE**PIS****E4/18-M****Large vaccine carrier:
Model 3504 UN/CF****COMPANY NAME AND ADDRESS**

The Thermos Company
 300 North Martingale Road
 Schaumburg, Illinois 60173
 United States of America
 Telephone: 1 (847) 240 31 90
 Fax: 1 (847) 240 32 06

SPECIFICATIONS

Vaccine storage capacity	1.7 litres
Weight fully loaded	5.1 kg.
Weight empty	2.5 kg.
External surface material	Polyethylene
Internal lining material	Polyethylene
Insulation material	Polyurethane
Insulation thickness	40 mm.
External dimensions	24x24x33 cm.
Internal dimensions	15x15x19 cm.
Vaccine storage dimensions	10x10x18 cm.
Lid type & fixings	Removable
Number of icepacks required	4
Number of icepacks supplied	4
Icepack type	Thermos*
Robustness in drop test:	Fittings+++Casing++
Cold life without openings	48 hrs. at +32°C 34 hrs. at +43°C
Cold life with openings	30 hrs at +32°C

COMMENTS

Test Reports: UNIVALLE C4-95-08 (1995)

Meets WHO/UNICEF Standard E4/VC.2

New model resistant to exposure to direct sunlight.
 Supplied with soft foam pad insert to hold 6 vaccine vials. Replacement foam pads available on request.

2000 PRICES (EX WORKS)

Shipping weight/volume kg / m³
Minimum order for direct shipment from factory: 4

Quantity/Price: 1/US\$ 19.73

- Icepacks supplied by Thermos do not meet WHO/UNICEF standards; may be purchased from Thermos at US\$72.96 for 96.*

CODE
PIS
E4/20

With
CFC

Small vaccine cold box, short range:
Model CB/INO/D1/90

COMPANY NAME AND ADDRESS

Ina ColdMed (formerly Hinardi Djajahardja)
Jl. Klingkit 3 No 86
Kompl. Bojong Indah
Jakarta 11740
Indonesia
Tel. / Fax: 62 (21) 581 1531

SPECIFICATIONS

Vaccine storage capacity	4.0 litres
Weight fully loaded	13.5 kg.
Weight empty	7.2 kg.
External surface material	Fibreglass
Internal lining material	Fibreglass
Insulation material	Polyurethane
Insulation thickness	75 mm.
External dimensions	39x39x41 cm.
Internal dimensions	24x24x24 cm.
Vaccine storage dimensions	16x16x16 cm.
Lid type & fixings	Hinged
Number of icepacks required	4x0.6l + 8x0.4 l
Number of icepacks supplied	0
Icepack type	E5/IP1,2
Robustness in drop test:	Fittings 3; Casing 4
Cold life without openings	+ hrs. at +32°C 83 hrs. at +43°C

COMMENTS

Test Reports: CRL.Z.9423 ; AIT/EP/91-4 (1991)
Meets WHO/UNICEF Standard E4/CB4
CFC-free version soon available.

2000 PRICES (EX WORKS)

Shipping weight/volume 15 kg / 0.125 m³
Minimum order 20

Quantity/Price: 1/US\$ 138.00

CODE
PIS
E4/22

With
CFC

Small vaccine cold box, long range

COMPANY NAME AND ADDRESS

Oyster Industries (Pvt.) Ltd.
130-G Phase 1, Commercial Zone,
L.C.C.H.S (Defence Society)
Lahore-54792, Pakistan
Telephone: 92 (42) 893903, 893944-5
Fax: 92 (42) 572 45 03, 572 15 28
E-mail: oyster@nexlinx.net.pk

SPECIFICATIONS

Vaccine storage capacity	9.75 litres
Weight fully loaded	32.9 kg.
Weight empty	17.6 kg.
External surface material	Fibreglass
Internal lining material	Fibreglass
Insulation material	Polyurethane
Insulation thickness	110 mm.
External dimensions	56x61x49 cm.
Internal dimensions	31x36x26 cm.
Vaccine storage dimensions	25x30x13 cm.
Lid type & fixings	Hinged
Number of icepacks required	24
Number of icepacks supplied	0
Icepack type	E5/02, 14
Robustness in drop test:	Fittings 3; Casing 2
Cold life without openings	152 hrs at +32°C 119 hrs at +43°C

COMMENTS

Test report: CATR-G.99220 (1980)
Meets WHO/UNICEF Standard E4/CB.1
A CFC free version is in development.

2000 PRICES (EX WORKS)

Shipping weight/vol (4 pcs) 82 kg / 0.29 m³
Minimum order 4

Quantity/Price: 1/US\$ 175.00

CODE**PIS****E4/34***With**CFC***Large vaccine carrier:
Model IA****COMPANY NAME AND ADDRESS**

Beijing Light Industrial Products
 Import & Export Corporation Limited
 17 Zhang Jing Guan Road
 Dong Cheng District
 100 007 Beijing, China
Telephone: 86 (1) 64 05 74 45 / 64 04 48 99
Fax: 86 (1) 64 05 74 27 / 64 05 74 57
E-mail: BLIC@TPBJC.GOV.CN

SPECIFICATIONS

Vaccine storage capacity	1.3 litres
Weight fully loaded	4.5 kg.
Weight empty	2.5 kg.
External surface material	PVC & fabric
Internal lining material	Polystyrene
Insulation material	Polyurethane
Insulation thickness	38 mm.
External dimensions	26x25x27 cm.
Internal dimensions	16x16x18 cm.
Vaccine storage dimensions	16x9x9 cm.
Lid type & fixings	Fabric hinge
Number of icepacks required	4
Number of icepacks supplied	4
Icepack type	E5/06, 10
Robustness in drop test:	Fittings 3; Casing 5
Cold life without openings	34 hrs. at +43°C

COMMENTS

Test Reports: Sisir B1-00877/NTC/TCH (1992)
Meets WHO/UNICEF Standard E4/VC.2
 Supplied with soft foam insert to hold vaccine vials.

2000 PRICES (FOB)

Shipping weight/vol (8 pcs) 38 kg / 0.18 m³
Minimum order: 96

Quantity/Price: 1/US\$ 11.00
 Replacement foam pads US\$0.40 each.

CODE**PIS****E4/37-M****Large vaccine cold box, long range:
Model KR 48****COMPANY NAME AND ADDRESS**

Savopak Oy
 P. O. Box 103
 78201 Varkaus
 Finland
Telephone: 358 (17) 288 35 00
Fax: 358 (17) 288 35 55
E-mail: savopak@or-group.fi

SPECIFICATIONS

Vaccine storage capacity	20.9 litres
Weight fully loaded	50.0 kg.
Weight empty	28.0 kg.
External surface material	Plywood
Internal lining material	Aluminium
Insulation material	Polyurethane
Insulation thickness	100 mm.
External dimensions	75x59x51 cm
Internal dimensions	50x34x25 cm
Vaccine storage dimensions	43x27x18 cm
Lid type & fixings	Removable
Number of icepacks required	24
Number of icepacks supplied	0
Icepack type	E5/04
Robustness in drop test:	Fittings 3; Casing 4
Cold life without openings	177 hrs. at +32°C 121 hrs. at +43°C

COMMENTS

Test Reports: Univalle CB.4 (1984)
Meets WHO/UNICEF Standard E4/CB.2

2000 PRICES (EX WORKS)

Shipping weight/vol (1 pce) 30 kg / 0.27 m³
Minimum order: 1

Quantity/Price: FIM 1 270.00 (US\$ 202.55)

CODE
PIS
E4/52-M



Large vaccine carrier

COMPANY NAME AND ADDRESS

Gio Style Spa
Via Battaina 12
24059 Urganano (Bergamo), Italy
Telephone: 39 (35) 419 2419
Fax: 39 (35) 419 2400
E-mail: tempolibero@giostyle.com

SPECIFICATIONS

Vaccine storage capacity	2.6 litres
Weight fully loaded	6.5 kg.
Weight empty	1.8 kg.
External surface material	Polypropylene
Internal lining material	Polypropylene
Insulation material	Polyurethane
Insulation thickness	25-35 mm.
External dimensions	32x27x25 cm.
Internal dimensions	24x18x22 cm.
Vaccine storage dimensions	15x15x12 cm.
Lid type & fixings	Removable
Number of icepacks required	8
Number of icepacks supplied	8
Icepack type	E5/10
Robustness in drop test:	Fittings 1; Casing 5
Cold life without openings	++ hrs. at +32°C 32 hrs. at +43°C

COMMENTS

*Test Reports: UNIVALLE E4/3004 (1996).
Meets WHO/UNICEF Standard E4/VC.2 except for its fittings, which are too fragile (rating 1 instead of 2).
Supplied with soft foam insert to hold vaccine vials.
Includes instructions in English and French re correct packing.*

2000 PRICES (EX WORKS)

Shipping weight/vol (8 pcs) 20 kg / 0.2 m³
Minimum order: 4

Quantity	Price/unit
1-1000	ITL 53 500.00 (US\$ 26.42)
1001+	ITL 48 000.00 (US\$ 23.70)

CODE
PIS
E4/53-M



Small vaccine carrier: Model RCW 2/CF (991.5903.01)

COMPANY NAME AND ADDRESS

Electrolux (Luxembourg) SARL
14, op der Hei
L-9809 Hosingen
Luxembourg
Telephone: 352 920 731
Fax: 352 920 731 300
e-mail: Pascal.Vannier@notes.electrolux.lu

SPECIFICATIONS

Vaccine storage capacity	0.6 litres
Weight fully loaded	2.1 kg.
Weight empty	1.2 kg.
External surface material	Polyethylene
Internal lining material	Polyethylene
Insulation material	Polyurethane foamed with cyclopentane
Insulation thickness	30 mm.
External dimensions	25x15x21 cm.
Internal dimensions	19x 9x13 cm.
Vaccine storage dimensions	18x 5x 7 cm.
Lid type & fixings	Hinged
Number of icepacks required	2
Number of icepacks supplied	2
Icepack type	E5/08
Robustness in drop test:	Fittings 3;Casing 5
Cold life without openings	++ hrs. at +32°C 17 hrs. at +43°C

COMMENTS

*Test Reports: UNIVALLE E4/3009 (1998).
Meets WHO/UNICEF Standard E4/VC.1
From 1998 this item will be colored in blue, as opposed to yellow previously. When ordering spare parts, please indicate the product number.*

2000 PRICES (FOT Luxembourg)

Shipping weight/vol (1 pce) 1.6 kg / 0.01 m³
Minimum order: 1

Quantity	Price/unit
1-39	XEU 41.00 (US\$ 37.27)
40-99	XEU 39.00 (US\$ 35.45)
100+	XEU 37.00 (US\$ 33.64)

CODE
PIS
E4/55-M



**Small Vaccine Carrier:
Model T.P.001**

COMPANY NAME AND ADDRESS

True Pack Ltd.
410 Century Boulevard
Boxwood Commerce Centre, Wilmington
Delaware 19808, USA
Telephone: 1 (302) 999 84 65 / (800) 825 78 90
Fax: 1 (302) 999 03 51
e-mail: truepack@prudigy.net

SPECIFICATIONS

Vaccine storage capacity	0.76 litres
Weight fully loaded	1.91 kg.
Weight empty	0.54 kg.
External surface material	Plastic
Internal lining material	Polyethylene
Insulation material	Isocynurate
Insulation thickness	36 mm.
External dimensions	29x21x25 cm.
Internal dimensions	13x12x17 cm.
Vaccine storage dimensions	9x5x17 cm.
Lid type & fixings	Foldable lid
Number of icepacks required	3
Number of icepacks supplied	0
Icepack type	E5/15
Robustness in drop test:	Fittings ; casing
Cold life without openings	++ hrs. at +32°C 21 hrs. at +43°C

COMMENTS

*Test report: UNIVALLE, E4/3005-02-97 (1997)
Meets WHO/UNICEF Standard E4/VC1*

2000 PRICES (FOB)

Shipping weight/volume kg / m³
Minimum order 25

Quantity/price set-up 1/US\$ 19.95
Flat 1/US\$ 18.95

CODE
PIS
E4/57-M



**Small vaccine cold box, short range:
Model 55-CF**

COMPANY NAME AND ADDRESS

Blow Kings
53 C Mittal Court ,Nariman Point,
Mumbai – 400 021
India
Telephone: 91(22) 284 01 20 / 284 0393/
282 66 78
Fax: 91 (22) 283 14 12
E-mail: blowkings@vsnl.com

SPECIFICATIONS

Vaccine storage capacity	8.6 litres
Weight fully loaded	(21.7) kg.
Weight empty	(8.2) kg.
External surface material	Plastic
Internal lining material	Plastic
Insulation material	Polyurethane
Insulation thickness	55 mm.
External dimensions	49x42x41 cm.
Internal dimensions	37x30x26 cm.
Vaccine storage dimensions	27x22x16 cm.
Lid type & fixings	Hinged
Number of icepacks required	24 (see comments)
Number of icepacks supplied	24 (see comments)
Icepack type	E5/12, 19
Robustness in drop test:	Fittings(2);Casing(4)
Cold life without openings	++ hrs. at +32°C (65) hrs. at +43°C

COMMENTS

*Test Reports: Blow Kings and Crown Agents (1997)
Meets WHO/UNICEF Standard E4/CB.4
Supplied with icepack E5/12 of 0.3 litre. Cold life is
65 hrs when E5/19 (0.4 litre) is used.
Other size models are available from the manufacturer.*

2000 PRICES (FOB)

Shipping weight/vol (1 pce) 10 kg/0.083 m³
Minimum order 1

Quantity/Price: 1/US\$ 90.00

CODE**PIS****E4/62-M**
**Small vaccine cold box, long range
Model RCW 12/CF (991 7701 01)**
COMPANY NAME AND ADDRESS

Electrolux (Luxembourg) SARL
14, op der Hei
L-9809 Hosingen
Luxembourg
Telephone: 352 920 731
Fax: 352 920 731 300
e-mail: Pascal.Vannier@notes.electrolux.lu

SPECIFICATIONS

Vaccine storage capacity	8.50 litres
Weight fully loaded	21.00 kg.
Weight empty	11.70 kg.
External surface material	Polyethylene
Internal lining material	Polyethylene
Insulation material	Polyurethane foamed with cyclopentane
Insulation thickness	9-11.5 cm.
External dimensions	50x55x47 cm.
Internal dimensions	29x34x26 cm.
Vaccine storage dimensions	19x26x18 cm.
Lid type & fixings	Hinged
Number of icepacks required	14
Number of icepacks supplied	14
Icepack type	E5/09
Robustness in drop test:	Fittings 2;Casing 1
Cold life without openings	++ hrs. at +32°C 114 hrs. at +43°C

COMMENTS

Test Reports: UNIVALLE E4/3010 (1998)
Meets WHO/UNICEF Standard E4/CB.1
From 1998 this item will be colored in blue, as opposed to yellow previously. When ordering spare parts, please indicate the product number.

2000 PRICES (FOT Luxembourg)

Shipping weight/volume (15.6 kg /0.15 m3)
Minimum order: 1

Quantity	Price/unit
1-39	XEU 353.00 (US\$ 320.91)
40-99	XEU 335.00 (US\$ 304.55)
100+	XEU 319.00 (US\$ 290.00)

CODE**PIS****E4/67-M**
**Large Vaccine carrier:
Model IVC-9AF**
COMPANY NAME AND ADDRESS

Apex Continental Limited
Surya Kiran, 19 Kasturba Gandhi Marg
New Delhi, 110 001 India
Telephone: 91 (11) 331 42 17 /541 14 59
Fax: 91 (11) 371 21 08/546 49 67
E-mail: apexint@mantraonline.com

SPECIFICATIONS

Vaccine storage capacity	1.6 litres
Weight fully loaded	4.3 kg.
Weight empty	1.9 kg.
External surface material	HDPE
Internal lining material	HIPS
Insulation material	Polyurethane
Insulation thickness	35-40 mm.
External dimensions (WxDxH)	25x25x29 cm.
Internal dimensions (WxDxH)	16x16x19 cm.
Vaccine storage dimensions	10x10x16 cm.
Lid type & fixings	Removable
Number of icepacks required	4 (see comments)
Number of icepacks supplied	4 (see comments)
Icepack type	E5/14, 15, 21
Robustness in drop test:	Fittings—;Casing 3
Cold life without openings	++ hrs. at +32°C 36 hrs. at +43°C

COMMENTS

Test Report: PSB (August 1997).
Meets WHO/UNICEF Standard E4/VC.2
Cold life is 39 hours when E5/14 (0.4 litre) is used.

2000 PRICES (FOB)

Shipping weight/vol (4 pcs) 10.81 kg/0.09 m3
Minimum order 4

Quantity/Price: 1/US\$ 13.40

CODE
PIS
E4/68-M



Small vaccine carrier:
Model IVC-8F

COMPANY NAME AND ADDRESS

Apex Continental Limited
Surya Kiran, 19 Kasturba Gandhi Marg
New Delhi, 110 001 India
Telephone: 91 (11) 331 42 17 /541 14 59
Fax: 91 (11) 371 21 08/546 49 67
E-mail: apexint@mantraonline.com

SPECIFICATIONS

Vaccine storage capacity	0.85 litres
Weight fully loaded	2.2 kg.
Weight empty	1.3 kg.
External surface material	HDPE
Internal lining material	HIP
Insulation material	Polyurethane
Insulation thickness	35/30 mm.
External dimensions	25x18x21 cm.
Internal dimensions	17x10x12 cm.
Vaccine storage dimensions	17x10x5 cm.
Lid type & fixings	Removable
Number of icepacks required	2
Number of icepacks supplied	2
Icepack type	E5/15
Robustness in drop test:	Fittings—;Casing 4
Cold life without openings	++ hrs. at +32°C 18.5 hrs. at +43°C

COMMENTS

Test Report: PSB (December 1997)
Meets WHO/UNICEF Standard E4/VC.1

2000 PRICES (FOB)

Shipping weight/vol (6 pcs) 10.2 kg/0.07 m³
Minimum order: 6

Quantity/Price: 1/US\$ 10.60

CODE
PIS
E4/69-M



Small vaccine carrier:
Model VDC-24-CF

COMPANY NAME AND ADDRESS

Blow Kings
53 C Mittal Court ,Nariman Point,
Mumbai – 400 021
India
Telephone: 91(22) 284 01 20 / 284 0393/
282 66 78
Fax: 91 (22) 283 14 12
E-mail: blowkings@vsnl.com

SPECIFICATIONS

Vaccine storage capacity	0.9 litres
Weight fully loaded	2.2 kg.
Weight empty	1.1 kg.
External surface material	Plastic
Internal lining material	Plastic
Insulation material	Polyurethane
Insulation thickness	23/35 mm.
External dimensions	22x15x25 cm.
Internal dimensions	13x10x17 cm.
Vaccine storage dimensions	6x10x17 cm.
Lid type & fixings	Removable
Number of icepacks required	2
Number of icepacks supplied	2
Icepack type	E5/12 , 19
Robustness in drop test:	Fittings 3; Casing 4
Cold life without openings	++ hrs. at +32°C 15.6 hrs. at +43°C

COMMENTS

Test Reports: CRL A.11622 (1996)
Meets WHO/UNICEF Standard E4/VC.0
Other size models are available from the manufacturer.

2000 PRICES (FOB)

Shipping weight/vol (12 pcs) 15 kg/ 0.12 m³
Minimum order: 1

Quantity/Price: 1/US\$ 10.00

CODE
PIS
E4/72-M



**Large vaccine cold box, long range:
Model ICB-11F**

COMPANY NAME AND ADDRESS

Apex Continental Limited
Surya Kiran, 19 Kasturba Gandhi Marg
New Delhi, 110 001 India
Telephone: 91 (11) 331 42 17 /541 14 59
Fax: 91 (11) 371 21 08/546 49 67
E-mail: apexint@mantraonline.com

SPECIFICATIONS

Vaccine storage capacity	23.1 litres
Weight fully loaded	48.9 kg.
Weight empty	18.6 kg.
External surface material	LLDPE
Internal lining material	LLDPE
Insulation material	Polyurethane
Insulation thickness	100 mm.
External dimensions (WxDxH)	77x62x52 cm.
Internal dimensions (WxDxH)	51x36x27 cm.
Vaccine storage dimensions	45x30x18 cm.
Lid type & fixings	Hinged
Number of icepacks required	50 (see comments)
Number of icepacks supplied	50 (see comments)
Icepack type	E5/15, 9, 22, 21
Robustness in drop test:	Fittings 3; Casing 2
Cold life without openings	++ hrs. at +32°C 100 hrs. at +43°C

COMMENTS

Test Report: PSB (August 1997).
Meets WHO/UNICEF Standard E4/CB.2
Cold life is 159 hrs when tested with 31 icepacks E5/09 (0.6 litre), but weight is then 50.5 kg, which exceeds the criteria for qualification for E4/CB.2

2000 PRICES (FOB)

Shipping weight/vol (1 pce) 25.4 kg/0.28 m³
Minimum order 1

Quantity/Price: 1/US\$ 183.00

CODE
PIS
E4/75-M



**Small vaccine cold box, long range:
Model ICB-8F**

COMPANY NAME AND ADDRESS

Apex Continental Limited
Surya Kiran, 19 Kasturba Gandhi Marg
New Delhi, 110 001 India
Telephone: 91 (11) 331 42 17 /541 14 59
Fax: 91 (11) 371 21 08/546 49 67
E-mail: apexint@mantraonline.com

SPECIFICATIONS

Vaccine storage capacity	5 litres
Weight fully loaded	25.0 kg.
Weight empty	11.8 kg.
External surface material	LLDPE
Internal lining material	LLDPE
Insulation material	Polyurethane
Insulation thickness	100 mm.
External dimensions (WxDxH)	79x41x43 cm.
Internal dimensions (WxDxH)	58x18x20 cm.
Vaccine storage dimensions	50x10x10 cm.
Lid type & fixings	Hinged
Number of icepacks required	26
Number of icepacks supplied	26
Icepack type	E5/15
Robustness in drop test:	Fittings 3; Casing 4
Cold life without openings	++ hrs. at +32°C 98 hrs. at +43°C

COMMENTS

Test Report: PSB (March 1998)
Meets WHO/UNICEF Standard E4/CB.1

2000 PRICES (FOB)

Shipping weight/vol (1 pce) 15.9 kg/0.17 m³
Minimum order 1

Quantity/Price: 1/US\$ 102.00

CODE
PIS
E4/76-M



Large vaccine cold box, long range:
Model CB/20/5U -CF

COMPANY NAME AND ADDRESS

Blow Kings
53 C Mittal Court ,Nariman Point,
Mumbai – 400 021
India
Telephone: 91(22) 284 01 20 / 284 0393/
282 66 78
Fax: 91 (22) 283 14 12
E-mail: blowkings@vsnl.com

SPECIFICATIONS

Vaccine storage capacity	(20) litres
Weight fully loaded	(49) kg.
Weight empty	(20.7) kg.
External surface material	Plastic
Internal lining material	Plastic
Insulation material	Polyurethane
Insulation thickness	110 mm.
External dimensions	78x54x55 cm.
Internal dimensions	56x32x33 cm.
Vaccine storage dimensions	46x23x19 cm.
Lid type & fixings	Hinged
Number of icepacks required	52
Number of icepacks supplied	52
Icepack type	E5/12 or E5/19
Robustness in drop test:	Fittings(3);Casing(4)
Cold life without openings	++ hrs. at +32°C (145) hrs. at +43°C

COMMENTS

Test Report: Blow kings (1997)
Meets WHO/UNICEF Standard E4/CB1
Supplied with icepack E5/12 of 0.3 litre. Cold life is (155) hrs when E5/19 (0.4 litre) is used.
Other size models are available from the manufacturer.

2000 PRICES (FOB)

Shipping weight/vol (1pce) 27.4 kg/0.23 m³
Minimum order

Quantity/Price: 1/US\$ 150.00

CODE
PIS
E4/77-M



Large vaccine carrier:
Model VC/42/MOD/2/CF

COMPANY NAME AND ADDRESS

Blow Kings
53 C Mittal Court ,Nariman Point,
Mumbai – 400 021
India
Telephone: 91(22) 284 01 20 / 284 0393/
282 66 78
Fax: 91 (22) 283 14 12
E-mail: blowkings@vsnl.com

SPECIFICATIONS

Vaccine storage capacity	1.5 litres
Weight fully loaded	3.7 kg.
Weight empty	1.8 kg.
External surface material	Plastic
Internal lining material	Plastic
Insulation material	Polyurethane
Insulation thickness	35-40 mm.
External dimensions	25x25x28 cm.
Internal dimensions	16x16x17 cm.
Vaccine storage dimensions	9x9x17 cm.
Lid type & fixings	Removable
Number of icepacks required	4
Number of icepacks supplied	4
Icepack type	E5/12
Robustness in drop test:	Fittings 3;Casing 4
Cold life without openings	++ hrs. at +32°C (36) hrs. at +43°C

COMMENTS

Test Reports: Blow kings / Crown Agents (1997)
Meets WHO/UNICEF Standard E4/VC.2
Supplied with icepack E5/19 Cold Life is (39) hrs.
Supplied with soft foam insert to hold vaccine vials.
Replacement foam pads on request.
Other size models are available from the manufacturer.

2000 PRICES (FOB)

Shipping weight/vol (8 pcs) 18 kg/0.16 m³
Minimum order 100

Quantity/Price: 1/US\$ 12.50

CODE
PIS
E4/78-M



**Small vaccine cold box, long range:
Model CB/5/2A/CF**

COMPANY NAME AND ADDRESS

Blow Kings
53 C Mittal Court ,Nariman Point,
Mumbai – 400 021
India
Telephone: 91(22) 284 01 20 / 284 0393/
282 66 78
Fax: 91 (22) 283 14 12
E-mail: blowkings@vsnl.com

SPECIFICATIONS

Vaccine storage capacity	(7.2) litres
Weight fully loaded	(26.8) kg.
Weight empty	(14.8) kg.
External surface material	Plastic
Internal lining material	Plastic
Insulation material	Polyurethane
Insulation thickness	110 mm.
External dimensions	82x36x38 cm.
Internal dimensions	65x19x18 cm.
Vaccine storage dimensions	50x12x12 cm.
Lid type & fixings	Hinged
Number of icepacks required	26
Number of icepacks supplied	26
Icepack type	E5/12 or E5/19
Robustness in drop test:	Fittings(2);Casing(4)
Cold life without openings	++ hrs. at +32°C (98) hrs. at +43°C

COMMENTS

Test Report: Blow Kings (1997)
Meets WHO/UNICEF Standard E4/CB.1
Supplied with icepack E5/12 of 0.3 litre. Cold life is 105 hrs when E5/19 (0.4 litre) is used.
Other size models are available from the manufacturer.

2000 PRICES (FOB)

Shipping weight/vol (1pce) 16 kg/0.12 m³
Minimum order 1

Quantity/Price: 1/US\$ 120.00

CODE
PIS
E4/79

With
CFC

Small vaccine carrier

COMPANY NAME AND ADDRESS

Promociones LISA S.A.
Av. Santa Cruz 398
San Isidro
Lima, Peru
Telephone: 51 (1) 441 5366/441 9992 /
421 6253
Fax: 51 (1) 441 7407
E-mail: lisavts@attglobal.net

SPECIFICATIONS

Vaccine storage capacity	0.7 litres
Weight fully loaded	2.885 kg.
Weight empty	1.443 kg.
External surface material	HDPE plastic
Internal lining material	HDPE plastic
Insulation material	Polyurethane
Insulation thickness	40 mm.
External dimensions	28x21x25 cm.
Internal dimensions	18x12x14 cm.
Vaccine storage dimensions	12x7x8 cm.
Lid type & fixings	Removable
Number of icepacks required	8
Number of icepacks supplied	8
Icepack type	Losani 0.125 l.*
Robustness in drop test:	Fittings 2; Casing 3
Cold life without openings	38 hrs. at +32°C 27 hrs. at +43°C

COMMENTS

Test Report: Univalle, March 1990
Meets WHO/UNICEF Standard E4/VC.1
Supplied with soft foam insert to hold vaccine vials.
Replacement foam pads US\$ 2.00 FCA.

2000 PRICES (FOB)

Shipping weight/volume kg / m³
Minimum order 2000

Quantity/Price: 1/US\$ 18.50

* *Icepacks supplied by LISA Promotions do not meet WHO/UNICEF standards, but may be purchased from Losani, US\$4.00 for 8.*

CODE
PIS
E4/80-M



**Small vaccine cold box, short range
Model 390**

COMPANY NAME AND ADDRESS

Polyfoam Packers Corporation
2320 S. Foster
Wheeling, Illinois 60090
United States of America
Telephone: 1 (847) 398 0110
Fax: 1 (847) 398 0653
E-mail: info@polyfoam.com

SPECIFICATIONS

Vaccine storage capacity	9.2 litres
Weight fully loaded	21.6 kg.
Weight empty	6.88 kg.
External surface material	Plastic
Internal lining material	Plastic
Insulation material	Polyurethane
Insulation thickness	35/40 mm.
External dimensions	54x38x35 cm.
Internal dimensions	42x26x27 cm.
Vaccine storage dimensions	32x18x16 cm.
Lid type & fixings	Hinged
Number of icepacks required	27
Number of icepacks supplied	0
Icepack type	E5/02
Robustness in drop test:	Fittings+++; Casing++
Cold life without openings	70 hrs. at +32°C 52 hrs. at +43°C

COMMENTS

Test Report: Univalle (1991)
Meets WHO/UNICEF Standard E4/CB.4

2000 PRICES (FOB)

Shipping weight/volume kg / m³
Minimum order: 1

Quantity/Price: 1/ US\$ 145.00

CODE
PIS
E4/81-M



**Large vaccine carrier (Blue):
Model: CFC free**

COMPANY NAME AND ADDRESS

Nylex Packaging PTY Ltd.
80 Hartnet Drive
Seaford
Victoria 3198, Australia
Telephone: 61 (03) 92 13 52 22
Fax: 61 (03) 97 86 47 85
Email: sales@nylexpackaging.com.au

SPECIFICATIONS

Vaccine storage capacity	1.4 litres
Weight fully loaded	5.3 kg.
Weight empty	2.4 kg.
External surface material	Plastic HD Polyethylene
Internal lining material	Plastic Polyprop.
Insulation material	Polyurethane
Insulation thickness	50/60 mm.
External dimensions	37x25x35 cm.
Internal dimensions	22x13x20 cm.
Vaccine storage dimensions	12x6x20 cm.
Lid type & fixings	Removable with toggle clips
Number of icepacks required	4
Number of icepacks supplied	4
Icepack type	E5/09
Robustness in drop test:	Fittings 2; Casing 4
Cold life without openings:	53 hours at +43°C

COMMENTS

Test Reports: CRL A.11622 (1996)
Meets WHO/UNICEF Standard E4/VC.2
Replacement foam pads on request.

2000 PRICES (FOB)

Shipping weight/volume 2.5 / 0.034 kg/m³
Minimum order: 50

Quantity/Price: 50-100 1/US\$ 46.31
101-500 1/US\$ 44.00
501-1000 1/US\$ 41.80
1001+: price on application

CODE
PIS
E4/83-M



Large vaccine carrier:
Model BK-VC 1.6 - CF

COMPANY NAME AND ADDRESS

Blow Kings
53 C Mittal Court ,Nariman Point,
Mumbai – 400 021
India
Telephone: 91(22) 284 01 20 / 284 0393/
282 66 78
Fax: 91 (22) 283 14 12
E-mail: blowkings@vsnl.com

SPECIFICATIONS

Vaccine storage capacity	1.7 litres
Weight fully loaded	4.5 kg.
Weight empty	1.8 kg.
External surface material	Plastic
Internal lining material	Plastic
Insulation material	Polyurethane
Insulation thickness	40 mm.
External dimensions	27x26x28 cm.
Internal dimensions	17x17x17 cm.
Vaccine storage dimensions	10x10x17 cm.
Lid type & fixings	Removable
Number of icepacks required	4
Number of icepacks supplied	4
Icepack type	E5/12, E5/19
Robustness in drop test:	Fittings 3; Casing 4
Cold life without openings	++ hrs. at +32°C 36 hrs. at +43°C

COMMENTS

Test Reports: CRL A.11622 (1996)
Meets WHO/UNICEF Standard E4/VC.2
Other size models are available from the manufacturer.

2000 PRICES (FOB)

Shipping weight/vol (8 pcs) 20 kg/ 0.16 m³
Minimum order: 1

Quantity/Price: 1/US\$ 12.50

CODE
PIS
E4/84-M



Vaccine carrier for NID:
Model Frigivac for Kick Polio

COMPANY NAME AND ADDRESS

CIP Industries
PO Box 1782
Randburg 2125
South Africa
Telephone: 27 (11) 793 44 20
Fax: 27 (11) 793 57 12
E-mail: carpentr@icon.co.za

SPECIFICATIONS

Vaccine storage capacity	1.7 litres
Weight fully loaded	2.34 kg.
Weight empty	0.42 kg.
External surface material	Wax coated corr. cardboard, stitched seams, stapled bottom
Internal lining material	Polyethylene
Insulation material	Polyurethane
Insulation thickness	30 mm.
External dimensions	255x157x261 mm
Internal dimensions	190x90x185 mm
Vaccine storage dimensions	125x90x165 mm
Lid type & fixings	Folded and fastened with plastic turn lock.
Number of icepacks required	3
Number of icepacks supplied	1 ice bag
Icepack type	E5/12
Robustness in drop test:	Casing 3; Fitting 3
Cold life without openings	
with icepacks:	15.5 hrs. at +43°C
with ice in bag:	5.5 hrs. at +43°C

COMMENTS

Test Reports: CSIR MST (96) MP17(1996);
UNIVALLE E4/3008-02-97 (1997)
Meets WHO/UNICEF Standard E4/VC.0 if tested with
3 standard icepacks E5/12.

2000 PRICES (FOB)

Shipping weight/vol (80 pcs, 1 pallet) 53.5 kg/ 0.988
m³
Shipping dimensions 1060x1060x880m *m*
Minimum order: 160 pieces (2 pallets)

Quantity/Price: 1/US\$ 3.00
Pallet of 80/US\$ 240.00

CODE
PIS
E4/85-M



**Small vaccine cold box, short range:
Model RCW 8/CF (958.4802.01)**

COMPANY NAME AND ADDRESS

Electrolux (Luxembourg) SARL
14, op der Hei
L-9809 Hosingen
Luxembourg
Telephone: 352 920 731
Fax: 352 920 731 300
e-mail: Pascal.Vannier@notes.electrolux.lu

SPECIFICATIONS

Vaccine storage capacity	5.30 litres
Weight fully loaded	(13.80) kg.
Weight empty	7.02 kg.
External surface material	Polyethylene
Internal lining material	Polyethylene
Insulation material	Polyurethane foamed with cyclopentane
Insulation thickness	60-65 mm.
External dimensions	43.5x59x29 cm.
Internal dimensions	24.5x46x16 cm.
Vaccine storage dimensions	(19x37.5x7.5) cm.
Lid type & fixings	Hinged
Number of icepacks required	10
Number of icepacks supplied	10
Icepack type	E5/09
Robustness in drop test:	Fittings++;Casing++
Cold life without openings	++ hrs. at +32°C 49.5 hrs. at +43°C

COMMENTS

*Test Report: GET January 1998), Electrolux (1995)
Meets WHO/UNICEF Standard E4/CB.4*
When ordering spare parts, please indicate the product number.

2000 PRICES (FOT Luxembourg)

Shipping weight/volume (10.2 kg /0.1 m³)
Minimum order: 1

Quantity	Price/unit
1-39:	XEU 183.00 (US\$ 166.36)
40-99:	XEU 174.00 (US\$ 158.18)
100+ :	XEU 165.00 (US\$ 150.00)

CODE
PIS
E4/86-M



**Large vaccine cold box, short range:
Model ICB-14F**

COMPANY NAME AND ADDRESS

Apex Continental Limited
Surya Kiran, 19 Kasturba Gandhi Marg
New Delhi, 110 001 India
Telephone: 91 (11) 331 42 17 /541 14 59
Fax: 91 (11) 371 21 08/546 49 67
E-mail: apexint@mantraonline.com

SPECIFICATIONS

Vaccine storage capacity	15 litres
Weight fully loaded	33.3 kg.
Weight empty	11.2 kg.
External surface material	LLDPE
Internal lining material	LLDPE
Insulation material	Polyurethane
Insulation thickness	60 mm.
External dimensions (WxDxH)	72x43x40 cm.
Internal dimensions (WxDxH)	57x28x24 cm.
Vaccine storage dimensions	49x20x16 cm.
Lid type & fixings	Hinged
Number of icepacks required	22
Number of icepacks supplied	22
Icepack type	E5/21, E5/09
Robustness in drop test:	Fittings 2; Casing 2
Cold life without openings	++ hrs. at +32°C 61 hrs. at +43°C
Warm life without openings	37.5 hrs. at -20°C

COMMENTS

*Test Report: PSB (December 1998).
Meets WHO/UNICEF Standard E4/CB.3*

2000 PRICES (FOB)

Shipping weight/vol (1 pce) 16.5 kg/0.13 m³
Minimum order 1

Quantity/Price: 1/US\$ 125.-

CODE
PIS
E4/87-M



**Large vaccine cold box, short range:
Model LCB-8A**

COMPANY NAME AND ADDRESS

Beijing Municipal Sanitation and Antiepidemic Cold-Chain Company Ltd.
16 Middle Street, Hepingli
Beijing
China
Telephone: 86 (10) 64 21 84 55
Fax: 86 (10) 64 21 43 05

SPECIFICATIONS

Vaccine storage capacity	1.60 litres
Weight fully loaded	4.80 kg.
Weight empty	2.4 kg.
External surface material	Plastic
Internal lining material	Plastic
Insulation material	Polyurethane
Insulation thickness	40 mm.
External dimensions	31x21x26 cm.
Internal dimensions	22.9x13.1x16.5 cm.
Vaccine storage dimensions	15.9x6.1x16.5 cm.
Lid type & fixings	Hinged
Number of icepacks required	6
Number of icepacks supplied	6
Icepack type	0.4 litres
Robustness in drop test:	Fittings 3; Casing 5
Cold life without openings	50 hrs. at +43°C

COMMENTS

Test Report: China NHEAC WB-98-023(December 1998),
Meets WHO/UNICEF Standard E4/VC.2.

2000 PRICES (FOB)

Shipping weight/volume (14.6 kg /0.08 m³)
Minimum order: 4

Quantity/Price: 1/US\$ 12.80

CODE
PIS
E4/88-M



**Large vaccine carrier:
Model CB/10 - CF**

COMPANY NAME AND ADDRESS

Blow Kings
53 C Mittal Court ,Nariman Point,
Mumbai – 400 021
India
Telephone: 91(22) 284 01 20 / 284 0393/
282 66 78
Fax: 91 (22) 283 14 12
E-mail: blowkings@vsnl.com

SPECIFICATIONS

Vaccine storage capacity	10.0 litres
Weight fully loaded	33.8 kg.
Weight empty	17.5 kg.
External surface material	Plastic
Internal lining material	Plastic
Insulation material	Polyurethane
Insulation thickness	100 mm.
External dimensions	57x56x53 cm.
Internal dimensions	37x37x29 cm.
Vaccine storage dimensions	25x20x20 cm.
Lid type & fixings	Hinged
Number of icepacks required	17
Number of icepacks supplied	17
Icepack type	0.6 litre
Robustness in drop test:	Fittings 3; Casing 4
Cold life without openings	++ hrs. at +32°C 95 hrs. at +43°C

COMMENTS

Test Reports: Blow Kings and SGS India Ltd
Inspection certificate No. SGS/BRD/UNICEF/148/99
(August '99)
Meets WHO/UNICEF Standard E4/CB.1
Other size models are available from the manufacturer.

2000 PRICES (FOB)

Shipping weight/vol (1 pce) 21 kg/ 0.18 m³
Minimum order: 1

Quantity/Price: 1/US\$ 12.80 1/US\$ 140

Section E5

Icepacks

1. Introduction

The icepacks listed in the Product Information Sheets (PIS) are all suitable for use in the transport of vaccines.

In selecting icepacks for a programme, consider the following points:

- The icepacks should be a suitable size for the freezers, cold boxes and vaccine carriers available locally and/or being used or purchased for your programme. Each sheet states which cold box/vaccine carrier the icepack is suitable for.
- For the sake of rotation and to cope with loss it is useful to have an extra set of icepacks per cold box or vaccine carrier (one set for freezing while one set is being used). One set is already supplied with most boxes and carriers.

Two standard sizes exist in the EPI for icepacks:

- The 0.4 litre icepack, which corresponds with the dimensions of E5/02 for example, is used in vaccine carriers.
- The 0.6 litre icepack, which corresponds with the dimensions of E5/04 for example, is used in cold boxes (both long and short range) and in vaccine packaging.

Attention

- EPI recommendations discourage the practice of standing opened vaccine vials in icepack "holes" during immunization sessions. It is preferable to fit a thick piece of soft plastic foam (30–50 mm) tightly into the top of the vaccine carrier, with slits cut into the foam to hold the vials. This serves (i) to keep the vials at a lower temperature and (ii) to extend the cold life of the vaccine carrier since the icepacks are not taken out during the session.
- Pre-filled icepacks are usually not recommended. They often contain a eutectic product (blue), which may have a lower freezing point than water, thus endangering the vaccines that should not be frozen.

CODE**PIS****E5/04****Icepack, 0.6 litre (Reference 38095)
Model 600, Isa Polar Maxi****COMPANY NAME AND ADDRESS**

Runsven AB

P. O. Box 143

Skanninge S-596 23

Sweden

Telephone: 46 (142) 465 00*Fax:* 46 (142) 422 10**SPECIFICATIONS**

Volume of ice per pack	0.60 litres
External dimensions	190x120x35 mm.
Weight empty	100 grams
Weight filled	700 grams

PERFORMANCE

Used with the following boxes/carriers:
E4/37-M, 42

COMMENTS

*Test Reports: CATR.Z.9979 & 1 (1979)
Meets WHO/UNICEF Standard E5/IP.1*

2000 PRICES (FOB)

*Shipping weight/vol. (270 pcs) 17.75 kg/0.2 m³
Minimum order: 25 (1 set)*

Quantity/Price: 1 set/US\$ 20.00**CODE****PIS****E5/06****Icepack, 0.4 litre****COMPANY NAME AND ADDRESS**

Beijing Light Industrial Products

Import & Export Corporation Limited

17 Zhang Jing Guan Road

Dong Cheng District

100 007 Beijing, China

Telephone: 86 (1) 64 05 74 45 / 64 04 48 99*Fax:* 86 (1) 64 05 74 27 / 64 05 74 57*E-mail:* BLIC@TPBJC.GOV.CN**SPECIFICATIONS**

Volume of ice per pack	0.37 litres
External dimensions	161x92x34 mm.
Weight empty	63 grams
Weight filled	433 grams

PERFORMANCE

Used with the following boxes/carriers: E4/34

COMMENTS

*Test Reports: CRL A.9022, January 1990
Meets WHO/UNICEF Standard E5/IP.2*

2000 PRICES (FOB)

*Shipping weight (120 pcs) 9 kg
Minimum order: 1200*

Quantity/Price: 1/US\$ 0.35

CODE**PIS****E5/08****Icepack, 0.3 litre****(set: 292.8508.53)****COMPANY NAME AND ADDRESS**

Electrolux (Luxembourg) SARL
 14, op der Hei
 L-9809 Hosingen
 Luxembourg
Telephone: 352 920 731
Fax: 352 920 731 300
e-mail: Pascal.Vannier@notes.electrolux.lu

SPECIFICATIONS

Volume of ice per pack 0.37 litres
External dimensions 17.3x12.0x2.6cm
Weight empty 68 grams
Weight filled 438 grams

PERFORMANCE

Used with the following boxes/carriers:
 E4/53-M, 70-M

COMMENTS

Test Reports: CRL A.9022, January 1990
Dimensions do not meet WHO/UNICEF Standards.

2000 PRICES (FOT Luxembourg)

Shipping weight/vol (1 set) 3 kg /0.025 m³
Minimum order : 1 Set of 40

Quantity	Price per set		
1-39 sets	XEU	34.00	(US\$ 30.91)
40-99 sets	XEU	32.00	(US\$ 29.09)
100+ sets	XEU	31.00	(US\$ 28.18)

CODE**PIS****E5/09****Icepack, 0.6 litre****(set: 292.8508.51)****COMPANY NAME AND ADDRESS**

Electrolux (Luxembourg) SARL
 14, op der Hei
 L-9809 Hosingen
 Luxembourg
Telephone: 352 920 731
Fax: 352 920 731 300
e-mail: Pascal.Vannier@notes.electrolux.lu

SPECIFICATIONS

Volume of ice per pack 0.58 litres
External dimensions 18.9x12.0x3.5 cm.
Weight empty 78 grams
Weight filled 658 grams

PERFORMANCE

Used with the following boxes/carriers:
 E4/05-M, 62-M, 81-M

COMMENTS

Test Reports: CRL A.9022, January 1990
WHO/UNICEF Standard E5/IP.1

2000 PRICES (FOT Luxembourg)

Shipping weight/vol (1 set) 3 kg /0.025 m³
Minimum order: 1 Set of 24

Quantity:	Price per set		
1-39	XEU	25.00	(US\$ 22.73)
40-99	XEU	24.00	(US\$ 21.82)
+100	XEU	23.00	(US\$ 20.91)

CODE
PIS
E5/10

Icepack, 0.4 litre
Model 400 CC

COMPANY NAME AND ADDRESS

Gio Style SPA
Via Battaina 12
24059 Urganano (Bergamo)
Italy
Telephone: 39 (35) 419 2419
Fax: 39 (35) 419 2400
E-mail: tempolibero@giostyle.com

SPECIFICATIONS

Volume of ice per pack	0.39 litres
External dimensions	165x93x33 mm.
Weight empty	50 grams
Weight filled	410 grams

PERFORMANCE

Used with the following boxes/carriers:
E4/19, 34, 52-M

COMMENTS

Test Reports: CRL A.9022, January 1990
Meets WHO/UNICEF Standard E5/IP.2

2000 PRICES (EX WORKS)

Shipping weight/vol (60 pcs) 3.12 kg /0.04 m³
Minimum order: —

Quantity/Price: 1/ITL 1 200.00 (US\$.59)

CODE
PIS
E5/12

Icepack, 0.3 litre
Model BK-V4 H

COMPANY NAME AND ADDRESS

Blow Kings
53 C Mittal Court ,Nariman Point,
Mumbai – 400 021
India
Telephone: 91(22) 284 01 20 / 284 0393/
282 66 78
Fax: 91 (22) 283 14 12
E-mail: blowkings@vsnl.com

SPECIFICATIONS

Volume of ice per pack	0.30 litres
External dimensions	163x90x33 mm.
Weight empty	78 grams
Weight filled	378 grams

PERFORMANCE

Used with the following boxes/carriers:
E4/57-M, 69-M, 76-M, 77-M, 78-M

COMMENTS

Test Reports: CRL A.9022, January 1990
Meets WHO/UNICEF Standard E5/IP.2

2000 PRICES (FOB)

Shipping weight/vol (225 pcs) 20 kg/ -- m³
Minimum order: Set of 10

Quantity/Price: 1 set/US\$ 4.00

CODE
PIS
E5/14

Icepack, 0.4 litre
Model reference: 38197

COMPANY NAME AND ADDRESS

Runsven AB
P. O. Box 143
Skanninge S-596 23
Sweden
Telephone: 46 (142) 465 00
Fax: 46 (142) 422 10

SPECIFICATIONS

Volume of ice per pack	0.40 litres
External dimensions	165x95x33 mm.
Weight empty	50 grams
Weight filled	450 grams

PERFORMANCE

Used with the following boxes/carriers:
E4/19, 22

COMMENTS

Test Reports: —
WHO/UNICEF Standard E5/IP.2

2000 PRICES (FOB)

Shipping weight/vol. (270 pcs) 13.75 kg/0.11cbm
Minimum order: 270

Quantity/Price: 1/US\$ 0.50

CODE
PIS
E5/15

Icepack, 0.3 litre

COMPANY NAME AND ADDRESS

Apex Continental Limited
Surya Kiran, 19 Kasturba Gandhi Marg
New Delhi, 110 001 India
Telephone: 91 (11) 331 42 17 /541 14 59
Fax: 91 (11) 371 21 08/546 49 67
E-mail: apexint@mantraonline.com

SPECIFICATIONS

Volume of ice per pack	0.31 litres
External dimensions	163x90x33 mm
Weight empty	79 grams
Weight filled	389 grams

PERFORMANCE

Used with the following boxes/carriers:
E4/67, 68, 72, 75

COMMENTS

Test Report: CRL A.9022, January 1990
Dimensions do not meet WHO/UNICEF Standards of 165x95x33 mm ±1 mm.

2000 PRICES (FOB)

Shipping weight/vol. (250 pcs) 23.3 kg/0.15 m3
Minimum order: 500

Price: If bought separately: 1/US\$0.36
(Packs are included in the cost of cold boxes E4/67, 68, 72, 75)

CODE**PIS****E5/16****Icepack 0.6 litre****COMPANY NAME AND ADDRESS**

Gio Style SPA
 Via Battaina 12
 24059 Urganano (Bergamo)
 Italy
Telephone: 39 (35) 419 2419
Fax: 39 (35) 419 2400
E-mail: tempolibero@giostyle.com

SPECIFICATIONS

Volume of ice per pack	0.50 litres
External dimensions	188x119x34 mm.
Weight empty	80 grams
Weight filled	570 grams

PERFORMANCE

Used with the following boxes/carriers
 E4/05-M

COMMENTS

Test Report: CRL A.9022, January 1990
Meets WHO/UNICEF Standard E5/IP.1

2000 PRICES (EX WORKS)

Shipping weight/vol (24 pcs) 2.2 kg / 0.22 m³
Minimum order : 40,000

Qty/Price 1/ITL 1 500.00 (US\$.74)

CODE**PIS****E5/17****Icepack, 0.4 litre****COMPANY NAME AND ADDRESS**

Garnia / Lameplast
 Via G. Verga 9-27
 41030 Rovereto di Novi
 Modena, Italy
Telephone: 39 (59) 672 651-8
Fax: 39 (59) 671 688

SPECIFICATIONS

Volume of ice per pack	0.35 litres
External dimensions	166x93x34 mm.
Weight empty	64 grams
Weight filled	414 grams

PERFORMANCE

Used with the following boxes/carriers:
 E4/53-M, 70-M

COMMENTS

Test Report: CRL A.9022, January 1990
Meets WHO/UNICEF Standard E5/IP.2

2000 PRICES (Ex Works)

Shipping weight/volume kg / m³
Minimum order : 15,000 pieces

Quantity	Price per unit
15000-30 000	ITL 865.00 (US\$.43)
30 000-50 000	ITL 825.00 (US\$.41)
50 000 +	ITL 785.00 (US\$.40)

CODE**PIS****E5/19****Icepack, 0.4 litre:
Model BK-4****COMPANY NAME AND ADDRESS**

Blow Kings
53 C Mittal Court ,Nariman Point,
Mumbai – 400 021
India
Telephone: 91(22) 284 01 20 / 284 0393/
282 66 78
Fax: 91 (22) 283 14 12
E-mail: blowkings@vsnl.com

SPECIFICATIONS

Volume of ice per pack	0.40 litres
External dimensions	164x94x34 mm.
Weight empty	65 grams
Weight filled	465 grams

PERFORMANCE

Used with the following boxes/carriers:
E4/57-M, 69-M, 76-M, 77-M, 78-M

COMMENTS

Test Reports: CRL A.9022, January 1990
Meets WHO/UNICEF Standard E5/IP.2

2000 PRICES (FOB)

Shipping weight/vol (225 pcs) 20 kg/ 0.13 m3
Minimum order: set of 10

Quantity/Price: 1 set/US\$ 4.00

CODE**PIS****E5/20****Icepack, 0.4 litre****COMPANY NAME AND ADDRESS**

Apex Continental Limited
Surya Kiran, 19 Kasturba Gandhi Marg
New Delhi, 110 001 India
Telephone: 91 (11) 331 42 17 /541 14 59
Fax: 91 (11) 371 21 08/546 49 67
E-mail: apexint@mantraonline.com

SPECIFICATIONS

Volume of ice per pack	0.35 litres
External dimensions	163x96x33 mm
Weight empty	(80) grams
Weight filled	428 grams

PERFORMANCE

Used with the following boxes/carriers:
E4/67-M, E4/72-M

COMMENTS

Test Report: PSB (December 1997)

2000 PRICES (FOB)

Shipping weight/vol. (240 pcs) 22.5 kg/ 0.16 m3
Minimum order: 480

Price: 1/US\$0.45

CODE
PIS
E5/21

Icepack, 0.6 litre

COMPANY NAME AND ADDRESS

Apex Continental Limited
Surya Kiran, 19 Kasturba Gandhi Marg
New Delhi, 110 001 India
Telephone: 91 (11) 331 42 17 /541 14 59
Fax: 91 (11) 371 21 08/546 49 67
E-mail: apexint@mantraonline.com

SPECIFICATIONS

Volume of ice per pack	0.58 litres
External dimensions	191x122x34 mm
Weight empty	(109) grams
Weight filled	672 grams

PERFORMANCE

Used with the following boxes/carriers: E4/72-M

COMMENTS

Test Report: PSB (December 1997)

2000 PRICES (FOB)

Shipping weight/vol. (160 pcs) 20.5 kg/ 0.15 m³
Minimum order: 480

Price: If bought separately: 1/US\$0.55

CODE
PIS
E5/22

Icepack, 0.4 litre

COMPANY NAME AND ADDRESS

Beijing Municipal Sanitation and Antiepidemic Cold-Chain Company Ltd.
16 Middle Street, Hepingli
Beijing
China
Telephone: 86 (10) 64 21 84 55
Fax: 86 (10) 64 21 43 05

SPECIFICATIONS

Volume of ice per pack	0.4 litres
External dimensions	165x95x33 mm
Weight empty	75 grams
Weight filled	425 grams

PERFORMANCE

Used with the following boxes/carriers: E4/57-M, 69-M, 76-M, 77-M, 78-M

COMMENTS

Test Report: China NHEAC WB-98-031(October 1998),

2000 PRICES (FOB)

Shipping weight/vol. (160 pcs) ++ kg/ ++ m³
Minimum order: 18,000

Price: 1/US\$0.24

CODE**PIS****E5/23****Icepack, 0.6 litre
Model BK- 6****COMPANY NAME AND ADDRESS**

Blow Kings

53 C Mittal Court ,Nariman Point,

Mumbai – 400 021

India

Telephone: 91(22) 284 01 20 / 284 0393/
282 66 78*Fax:* 91 (22) 283 14 12*E-mail:* blowkings@vsnl.com**SPECIFICATIONS**

Volume of ice per pack	0.55 litres
External dimensions	190x12x35 mm.
Weight empty	120 grams
Weight filled	670 grams

PERFORMANCE

Used with the following boxes/carriers:

E4/76-M

COMMENTS*Test Reports: Blowkings,(1999)**Meets WHO/UNICEF Standard E5/IP.1***2000 PRICES (FOB)***Shipping weight/vol (108 pcs) 14.7 kgs/0.09 m³**Minimum order: Set of 24***Quantity/Price:** 1 set/US\$ 14.00

Section E6

Thermometers, thermo ar

WARNING

Readers should note that PIS pages are **NO LONGER VALID** for the following categories due to the introduction of the PQS system:

PIS E08 Injection devices since 30 June 2005
PIS E06 Temperature monitoring devices since 1 October 2007

All items that appear in PIS 2000 Edition WHO/V&B/00.13 sections E08 and E06 along with all items listed in WHO web site http://www.who.int/immunization_standards/vaccine_quality/new_sheets_intro/en/index.html category are no longer recommended by the WHO.

Readers should consult the following pages for PQS prequalified devices and equipment for E06 and E08 categories:

http://www.who.int/immunization_standards/vaccine_quality/pqs_prequalified_devices_e08/en/index.html
http://www.who.int/immunization_standards/vaccine_quality/pqs_prequalified_devices_e06/en/index.html

1. Temperature monitoring in the cold chain

This section describes thermometers, thermo-recorders and chemical indicators for monitoring vaccine storage temperatures in the cold chain. The table below lists the types of instruments appropriate for use at different stages of the cold chain.

Type of use	Suitable instrument
<ul style="list-style-type: none"> • Transport from manufacturer to destined country: <ul style="list-style-type: none"> – measles, polio, BCG, DTP vaccines – DT and tetanus toxoid vaccines 	E6/16, 45 E6/15
<ul style="list-style-type: none"> • Central storage <ul style="list-style-type: none"> at 0–8 °C at –20 °C 	E6/16, 28, 29, 38, 39, 45 E6/16, 28, 29, 38, 39
<ul style="list-style-type: none"> • Transport to the regional store 	E6/14, 16, 30, 35
<ul style="list-style-type: none"> • Regional storage <ul style="list-style-type: none"> at 0–8 °C at –20 °C 	E6/14, 16, 28, 36, 38, 39 E6/16, 28, 36, 38, 39
<ul style="list-style-type: none"> • Transport to the district store 	E6/16, 30, 35
<ul style="list-style-type: none"> • District storage <ul style="list-style-type: none"> at 0–8 °C at –20 °C 	E6/16, 26, 27, 36 E6/16, 26, 27, 36
<ul style="list-style-type: none"> • Transport to the health centre 	E6/11, 26, 27, 30, 35
<ul style="list-style-type: none"> • Local storage 	E6/08, 09, 11, 16, 26, 27, 30, 35
<ul style="list-style-type: none"> • Transport in the field 	E6/08, 11, 26, 30, 35
<ul style="list-style-type: none"> • Multi-functioning cold chain supervision/assessment and equipment checking equipment 	E6/20, 32, 35, 42, 43, 44, 46, 47, 48

CODE
PIS
E6/08

**Vertical hanging vaccine
thermometer: Model 66/381/0**

COMPANY NAME AND ADDRESS

S. Brannan & Sons Ltd.
Leaconfield Industrial Estate, Cleator Moor
Cumbria CA25 5QE
United Kingdom
Telephone: 44 (1946) 81 06 00/81 66 25
Fax: 44 (1946) 81 66 25
E-mail: sales@brannan.co.uk

SPECIFICATIONS

Temperature range	-30 to +50°C
External dimensions	143x18x7 mm.
External materials	Plastic
Weight per unit	0.015 kg
Number per package	500

COMMENTS

Test Reports: CATR A.9116 (1986)
Meets WHO/UNICEF Standard E6/TH.3
Safe zones for vaccine storage are indicated by green solid blocks or lines.

2000 PRICES (FOB)

Shipping weight/vol (500 pcs) 0.014 kg/0.02 m³
Minimum order: 500 (1 package)

Quantity/Price: 1/US\$ 2.65

CODE
PIS
E6/09

**Recording thermometer:
Model 615.WHO*, 7 day, -40 to +70°C**

COMPANY NAME AND ADDRESS

Pacific Transducer Corporation
2301 Federal Avenue
Los Angeles, California 90064
United States of America
Telephone: 1 (310) 478 11 34
Fax: 1 (310) 312 08 26

SPECIFICATIONS

Temperature range	-40 to +70°C
External dimensions	80x100 mm.
External materials	Aluminium
Weight	0.41 kg
Number per package	1

COMMENTS

Test Reports: CATR. Z.9955/2 (1978)
Meets WHO/UNICEF Standard E6/TR.2
Includes polyethylene bag for protection against internal corrosion. Also available in Fahrenheit. Extra charts: Part No: 615.47CB (-40 to +70°C). Dry stylus operation. Carrying case, Part No. 615.99. Important to give entire product description and specify time/temperature range in your order.

2000 PRICES (FOB)

Shipping weight/volume 0.91 kg/0.0013 m³

Item	Number	Price/1
Thermometer	615.WHO	US\$ 305.00
Package charts (100)	615.47CB	US\$ 17.75
Carry case	615.99	US\$ 42.00

* Model 615.WHO includes thermometer, 100 charts, bag and 3-language decal.

CODE
PIS
E6/11

**Waterproof liquid crystal
thermometer: Model 2290**

COMPANY NAME AND ADDRESS

Hallcrest Inc.
1820 Pickwick Lane
Glenview, Illinois 60025
United States of America
Telephone: 1 (847) 998 8580
Fax: 1 (847) 998 6866

SPECIFICATIONS

Temperature range	0 to +20°C
External dimensions	123x37 mm.
External materials	Plastic
Weight	0.072 kg.
Number per package	25

COMMENTS

Test Summary: CCIS.83.8

Meets WHO/UNICEF Standard E6/TH5

This thermometer is supplied in moisture proof lamination with adhesive backing. Can be ordered without backing also, as Model 2291.

Warning: This thermometer is suitable only for indicating temperatures in cold boxes and vaccine carriers and is not suitable for use in refrigerators.

2000 PRICES (FOB)

Shipping volume 0.072 kg/0.0003 m³
Minimum order: \$100

Price/unit	
Model 2290	US\$ 0.93
Model 2291	US\$ 0.89

CODE
PIS
E6/15

DT & TT Shipping indicator

COMPANY NAME AND ADDRESS

Berlinger & Co. AG
Postfach 67
9608 Ganterschwil
Switzerland
Telephone: 41 (71) 982 88 11
Fax: 41 (71) 982 88 39
E-mail: info@berlinger.ch

SPECIFICATIONS

Temperature threshold	+48°C
External dimensions	120x90 mm.
External materials	Card
Weight (per package)	1.25 kg.
Number per package	600

COMMENTS

Test Report: Wolff Lab (1988)

Meets WHO/UNICEF Standard E6/IN1

Function: The temperature sensitive dot turns from silver grey to black instantaneously at temperatures above +48°C. This change is irreversible.

Use: The indicator is attached to each 3,000 doses of DT, DPT and TT vaccine in order to warn of high temperature exposure. Such temperatures are reached in poorly ventilated spaces exposed to the sun, e.g. in vehicles parked in the sun.

2000 PRICES (EX WORKS)

Shipping weight/vol (600) 1.25 kg/0.0036 m³
Minimum order: 600 (orders in multiples of 600)

Quantity	Price/unit
up to 2,000	1/CHF 0.88 (US\$.51)
2001-15,000	1/CHF 0.69 (US\$.40)
15,001 +	1/CHF 0.50 (US\$.29)

CODE
PIS
E6/16

Vaccine cold chain monitor card

COMPANY NAME AND ADDRESS

Berlinger & Co. AG
Postfach 67
9608 Ganterschwil
Switzerland
Telephone: 41 (71) 982 88 11
Fax: 41 (71) 982 88 39
E-mail: info@berlinger.ch

SPECIFICATIONS

Temperature thresholds	+10 and +34°C
External dimensions	120x150 mm.
External materials	Card
Weight	1.7 kg.
Number per package	250

COMMENTS

Test Report: Wolff Lab (1988)
Meets WHO/UNICEF Standard E6/IN2

Function: This indicator changes irreversibly from white to blue if exposed to temperatures higher than +10 and +34°C.

Use: Packaged with vaccine (1/3,000 doses) to monitor conditions in transit and in storage.

French and English stocked. Other language versions available on special order*.

2000 PRICES (EX WORKS)

Shipping weight/vol (250 pcs) 1.7 kg/0.0055 m3
Minimum order: 500 (2 cartons)

<u>Language</u>	<u>Price/unit</u>
English card	CHF 4.00 US\$ 2.33)
French card	CHF 4.00 US\$ 2.33)

* Other languages direct order from Berlinger at EXW price of CHF 4.00 each.

CODE
PIS
E6/26

Bimetal vaccine thermometer: Model 102475

COMPANY NAME AND ADDRESS

Möeller-Therm GmbH
Postfach 1260
D-97889 Kreuzwertheim
Federal Republic of Germany
Telephone: 49 (9342) 81 31
Fax: 49 (9342) 57 54

SPECIFICATIONS

Temperature range	-30 to +50°C
External dimensions	67x28 mm.
External materials	—
Weight	0.07 kg
Number per package	100

COMMENTS

Test Reports: CATR.A.9105 (1985)
Meets WHO/UNICEF Standard E6/TH.3

When ordering, safe temperature zones should be specified: 0 to +8, or -15 to -25°C.

2000 PRICES (EX WORKS)

Shipping weight/vol (100 pcs) 7 kg/ 0.055 m3
Minimum order: 100

Qty/price	1/DEM	4.95	(US\$	2.41)
------------------	-------	------	-------	-------

CODE
PIS
E6/27

**Alcohol stem thermometer:
Model 104614**

COMPANY NAME AND ADDRESS

Möeller-Therm GmbH
Postfach 1260
D-97889 Kreuzwertheim
Federal Republic of Germany
Telephone: 49 (9342) 81 31
Fax: 49 (9342) 57 54

SPECIFICATIONS

Temperature range -40 to +50°C
External dimensions 165x25x13 mm.
External materials Plastic
Weight 0.07 kg.
Number per package 100

COMMENTS

Test Reports: CATR A.9105 (1985)
Meets WHO/UNICEF Standard E6/TH.3
When ordering, safe temperature zones should be specified: 0 to +8, and -15 to -25°C.

2000 PRICES (EX WORKS)

Shipping weight/ vol (100 pcs) 10 kg/ 0.055 m³
Minimum order: 100

Qty/price 1/DEM 2.39 (US\$ 1.17)
(excl. packaging)

CODE
PIS
E6/28

**Recording thermometer:
Model AR10-GT-S**

COMPANY NAME AND ADDRESS

Hyoda Instruments Corporation
16-10 Kitahorie 1-Chome
Nishi-Ku, Osaka 550-0014
Japan
Telephone: 81 (6) 65 38 12 91
Fax: 81 (6) 65 39 26 17
E-mail: hyoda.ocn.ne.jp

SPECIFICATIONS

Temperature range -30 to +50°C
Hours per cycle 24 hrs
External dimensions 282x104 mm.
External materials Aluminium
Weight 8.5 kg.
Number per package 1

COMMENTS

Test Reports: CATR.A.9105 (1985)
Meets WHO/UNICEF Standard E6/TH.2
Capillary tube at the back of the case.
Number of probes: 1
Length of leads 1.5 metres
Standard Up to 3 metres

2000 PRICES (FCA, JAPAN AIRPORT)

Shipping weight/vol (1 pce) 8.5 kg/0.0218 m³
Minimum order: 1

Quantity	Price:
Recorder	50 000 (US\$ 463.18)
	JPY
10 nibs	JPY 20 000 (US\$ 185.27)
10 50cc ink bottles (blue or red)	JPY 222.30 (US\$ 2.06)
Chart Paper, (=1000 sheets)	JPY 2 000 (US\$ 36.56)

CODE
PIS
E6/29

Dial thermometer:
Model TFH 100 iF 1 + K1.21 + ma

COMPANY NAME AND ADDRESS

Rueger S.A.
Chemin de Mongevon 9
CH-1023 Crissier, Lausanne
Switzerland
Telephone: 41 (21) 637 32 32
Fax: 41 (21) 637 32 00
E-mail: info@rueger.ch

SPECIFICATIONS

Temperature range -30 to +50°C
External dimensions 102x95 mm.
External materials Stainless steel
Weight 0.838 kg.
Number per package 1

COMMENTS

Test Reports: CATR A.91992 (1987)
Meets WHO/UNICEF Standard E6/TH.2
Gas filled thermometer with back fixing flange and capillary tube at the back of the case. Supplied with 2 mechanical contacts (K1.21) and a cable junction box, as well as one index pointer.
Capillary length : 1.5 metres, with PVC covering.
Bulb: 9 x 100 mm diameter.

2000 PRICES (FOB)

Shipping weight/vol (1 pce) 0.84 kg/0.0075 m3
Minimum order: 1

Qty/Price: 1/CHF 440.00 (US\$ 255.81)

CODE
PIS
E6/30

Vaccine thermometer:
Model TSH 065 F

COMPANY NAME AND ADDRESS

Rueger S.A.
Chemin de Mongevon 9
CH 1023 Crissier, Lausanne
Switzerland
Telephone: 41 (21) 637 32 32
Fax: 41 (21) 637 32 00
E-mail: info@rueger.ch

SPECIFICATIONS

Temperature range -30 to +70°C
External dimensions 66x14 mm.
External materials Stainless steel
Weight 0.065 kg.
Number per package 1

COMMENTS

Test Reports: CATR A.91992 (1987)
Meets WHO/UNICEF Standard E6/TH.4
Bimetallic thermometer. Rolled stainless steel head, with back mounting flange in anodized aluminium.
Stainless steel stem: diameter 6 mm;
length 190 mm.
Supplied with unbreakable acrylic glass.

2000 PRICES (FOB)

Shipping weight/vol (1 pce) 0.065 kg/0.003 m3
Minimum order: 2

Quantity/Price: 1/CHF 50.00 (US\$ 29.07)

CODE**PIS****E6/32****Digital thermometer:
Model MT 160C****COMPANY NAME AND ADDRESS**

Tempcontrol I.E.P. B.V.
 Van Alphenstraat 63S
 Voorburg 2274 NC
 The Netherlands

Telephone: 31 (70) 347 64 31
 Fax: 31 (70) 382 55 16
 E-mail: info@tempcontrol.nl

SPECIFICATIONS

Temperature range -50 to +200°C
 External dimensions 150x63x26 mm.
 External materials Aluminium
 Weight 0.263 kg.
 Number per package 1

COMMENTS

Meets BS 5490: 1977

This model has not been independently tested.

The optional sensor is a general purpose probe, model No. G0234SE.

2000 PRICES (EX WORKS)

Shipping weight/vol (1 pce) 0.263 kg/0.075 m³
 Minimum order: 2

Quantity	Price/unit	
1 (excluding sensor)	NLG 400.00	(US\$ 173.16)
Sensor	NLG 246.00	(US\$ 106.49)

CODE**PIS****E6/35****Dial thermometer:
Model 10 259-04****COMPANY NAME AND ADDRESS**

Armatherm Gunthel GmbH
 Grevenmarschstrasse 38-40
 Postfach 260
 32632 Lemgo

Federal Republic of Germany
 Telephone: 49 (5261) 937 70
 Fax: 49 (5261) 937 751
 E-mail: info@armathermde

SPECIFICATIONS

Temperature range -30 to +30°C
 External dimensions 49x10 mm.
 External materials Stainless steel
 Weight 0.021 kg.
 Number per package —

COMMENTS

Test Reports: CATR A.9116 (1986)

Meets WHO/UNICEF Standard E6/TH.3

For mounting thermometer on a surface, the rear casing is equipped with either :

- a small threaded ferrule for screwing it on; or
- an adhesion foil for sticking it on.

Each instrument is quality checked and bears an official stamp.

2000 PRICES (FOB)

Shipping volume (50 pcs) 0.0167 m³
 Minimum order: 50

Quantity	Price/unit	
50-100	DEM 28.90	(US\$ 14.10)
101-250	DEM 27.45	(US\$ 13.39)
251-500	DEM 26.50	(US\$ 12.93)
501-1,000	DEM 25.85	(US\$ 12.61)

CODE
PIS
E6/36

Dial thermometer:
Model 704 KG 100

COMPANY NAME AND ADDRESS

Teck Instruments.
P.O. Box 11
N 3408 Tranby
Norway
Telephone: 47 (32) 851 950
Fax: 47 (32) 852 977
E-mail: sales@teck.no

SPECIFICATIONS

Temperature range -40 to +40°C
External dimensions 101x95 mm.
External materials Stainless steel
Weight 0.775 kg.
Number per package —

COMMENTS

Test Reports: CATR A.9116 (1986)
Meets WHO/UNICEF Standard E6/TH.4
Gas-filled thermometer.
Each extra metre of capillary tube costs an additional
US\$ 16.00.

2000 PRICES (FOB)

Shipping weight/vol (1 pce) 0.775 kg/0.03 m³
Minimum order: 1

Qty/Price: 1/NOK 1 682 (US\$ 188.14)

CODE
PIS
E6/38

Temperature recorder:
Model 13021.12

COMPANY NAME AND ADDRESS

Jules Richard Instruments
116 Quai de Bezons, B P 85
95101 Argenteuil Cedex
France
Telephone: 33 (1) 39 47 09 36
Fax: 33 (1) 39 47 00 94

SPECIFICATIONS

Temperature range -35 to +40°C
First channel: -35 to +15°C
Second channel: -10 to +40 °C
External dimensions 145x145x120 mm.
External materials Plastic
Weight 1.643 kg.
Number per package 1

COMMENTS

Test Reports: CATR. A.91992 (1987)
Meets WHO/UNICEF Standard E6/TR.2.
The product is supplied with 1 round/24 hours. It can
also be supplied with 1 round/7days (ref becomes
13021.17)
Numerous additional 1 or 2 channel recorders, with
temperature ranges from -100 to +600°C are available
on request.

2000 PRICES (FOB)

Shipping weight/vol (1 pce) 1.643 kg/0.020 m³
Minimum order: FFR 2 000.-

Quantity	Price:
Temperature recorder	
1-4 1/FRF	3 040.00 (US\$ 443.15)
5-9 1/FRF	2 880.00 (US\$ 419.83)
9+ 1/FRF	2 720.00 (US\$ 396.50)
Packet of 100 charts (ref D.32180)	FRF 150.00 (US\$ 21.87)
Pack of 5 pens (ref S.97601)	FRF 234.00 (US\$ 34.11)

CODE**PIS****E6/39****Recording thermometer:
Model EPI/RFBD****COMPANY NAME AND ADDRESS**

Foundrometers Instrumentation Ltd.
Unit 17, Enterprise Court, Pit Lane,
Micklefield, Leeds LS25 4BU
United Kingdom

Telephone: 44 (113) 287 44 11

Fax: 44 (113) 287 44 22

E-mail: sales@foundrometers.co.uk

SPECIFICATIONS

Temperature range	-40 to +40°C
Days per cycle	7 days
Power source	clockwork standard, electric optional
External dimensions	300x300x100 mm.
External materials	Bakelite
Weight	2.8 kg.
Length of capillary	15 metres
Number per package	1

COMMENTS

Test Summary: CCIS/80.7

Meets WHO/UNICEF Standard E6/TR.1.

Recording thermometer for cold rooms, without contacts. Capillary can be specified at different lengths.

The activating medium has changed from mercury to nitrogen.

Optional extras include 1 or 2 alarm contacts, event marker pens, temperature indicator scales. Different ranges available.

2000 PRICES (FOB)

Shipping volume (1 pce) 0.024 m³

Minimum order: 1

Item	Price/unit
Thermometer	GB£ 681.06 (US\$ 1 064.16)
Charts Z960 (pack of 100)	GB£ 36.50 (US\$ 57.03)
Fibre tipped cartridges (Ref: IUD 241[-R for red; per pack of 6 -B for blue; -G for green])	GB£ 60.00 (US\$ 93.75)
Pen conversion kit with remote inkpot (for early models)	GB£ 75.00 (US\$ 117.19)

CODE**PIS****E6/42****Temperature data logger -- TempTale****COMPANY NAME AND ADDRESS**

TSS AB
PO Box 7296
187 14 Täby, Sweden

Telephone: 46 8 630 06 06

Fax: 46 8 630 06 54

E-mail: michael@tss.se

SPECIFICATIONS

Temperature range	-30 to +85°C
Accuracy	± 0.5°C
Measuring interval	from 0.5 secs-2.13 hrs
Memory size	4K, 6K, 8K and 16K
Size (lxwxh)	88 x 50 x 15 mm
External materials	Plastic
Weight	0.085 kg.
Power source	Lithium battery
Battery life available	365 days

COMMENTS

Test Report: Certified by TUV, April 1995

No WHO/UNICEF Standard exists.

Use: TempCard is a portable, self-contained, user-programmable, temperature monitor for use with goods sensitive to temperature and/or humidity. As a "reusable cold chain monitor", it gives a complete history and is suitable for use in vaccine refrigerators, vaccine shipments and cold chain studies. Recorded data can be downloaded and stored via computer COM port connection to software in Dos or Windows format. Ambient or probe models available.

2000 PRICES (FOB)

Shipping volume 0.1088 m³

Minimum order: 1

Reusable* data logger	1/US\$ 121.00
Software and cable	1/US\$ 155.00
Complete demo package	1/US\$ 275.00
PC Interface	1/US\$ 99.00

*A single use model also available from \$45 and up.

CODE
PIS
E6/43

Temperature data logger:
Model Tiny TTM Type G

COMPANY NAME AND ADDRESS

Remonsys Ltd.
Goss House, 26 High Street
Street, Somerset BA16 OEB
United Kingdom
Telephone: +44 (1458) 84 00 88
Fax: +44 (1458) 84 11 88
E-mail: lewis@autolog.u-net.com

SPECIFICATIONS

Temperature range -40°C to +75°C
Accuracy ± 0.2°C
Measuring interval 0.5 secs to 4.8 hrs
Memory size 1800
Size (dxl) 30 x 50 mm.
External materials plastic case
Weight 0.05 kg.
Number per package 5
Power source battery 3.6 V
(1/2AA)
Battery life available 2 years

COMMENTS

Test Report: Univalle, 1992

No WHO/UNICEF Standard exists.

Use: Functions as a "reusable cold chain monitor" for use in vaccine refrigerators, shipments and cold chain studies. The TTM is battery operated and small enough to fit inside a 35 mm. plastic film container. It stores data which can be downloaded by special cable to the serial port of a PC computer with MS Windows supported software.

2000 PRICES (FOB)

Shipping volume (5 pcs) 555 cm

Item	Min. order.	Price/unit	
Tiny TTM Type G	5	1/GB£ 85.00	(US\$ 132.81)
Software	1	1/GB£ 80.00	(US\$ 125.00)
Interface cable	1	1/GB£ 20.00	(US\$ 31.25)

CODE
PIS
E6/44

Temperature data logger:
Model Tiny TTM G IP68

COMPANY NAME AND ADDRESS

Remonsys Ltd.
Goss House, 26 High Street
Street, Somerset BA16 OEB
United Kingdom
Telephone: +44 (1458) 84 00 88
Fax: +44 (1458) 84 11 88
E-mail: lewis@autolog.u-net.com

SPECIFICATIONS

Temperature range -40°C to +75°C
Accuracy ± 0.2°C
Measuring interval 0.5 secs to 4.8 hrs
Memory size 2048
Size (lxbxh) 70x60x50 mm.
External materials glass reinforced plastic
Weight 150 g.
Number per package 5
Power source battery 3.6 V
Battery life available 2 years

COMMENTS

Test Report: Univalle, 1992

No WHO/UNICEF Standard exists.

Use: Functions as a "reusable cold chain monitor" for use in vaccine refrigerators, shipments and cold chain studies. This version of Tiny TTM has a rugged enclosure. It stores data which can be downloaded by special cable to the serial port of a PC computer with MS Windows supported software.

2000 PRICES (FOB)

Shipping volume 0.001 m3

Item	Min. order	Price/unit	
Tiny TTM G IP 68	5	GB£ 115	(US\$ 179.69)
Software	1	GB£ 80	(US\$ 125.00)
Interface cable	1	GB£ 20	(US\$ 31.25)

CODE**PIS****E6/45****Freeze watch indicator (0°C):
Model recorder number: 9805****COMPANY NAME AND ADDRESS**

Berlinger & Co. AG

Postfach 67

9608 Ganterschwil

Switzerland

Telephone: 41 (71) 982 88 11*Fax:* 41 (71) 982 88 39*E-mail:* info@berlinger.ch**SPECIFICATIONS**

Temperature threshold	0°C
External dimensions	60x40x10 mm.
External materials	PVC Plastic
Weight	0.016 kg.
Number per package	400

COMMENTS*Test Summary: CCIS.83.8**Meets WHO/UNICEF Standard E6/IN3*

An irreversible temperature indicator which shows if a product, such as vaccine, has been exposed to freezing temperatures. It consists of a white backing card with a small vial of blue liquid, all contained in a plastic casing. If the indicator is exposed to temperatures below 0°C for more than one hour, the vial bursts and releases the blue liquid, staining the white backing card. The indicator is used to warn of freezing and is packed with DPT, TT and DT vaccines (freezing point of -6.5°C) as well as with Hepatitis B (-0.5°C). It replaces E6/14, that bursts at -4.5°C. This change is due to the introduction of Hepatitis B, with a freezing point of -0.5°C, in the standard EPI schedule. Shelf life is three years.

2000 PRICES (Ex works, USA)*Shipping weight/vol (400 pcs)* 6.5 kg/ 0.033 m³*Minimum order:* 400

Quantity		Price/unit	
400-999	1/CHF	4.10	(US\$ 2.38)
1000-1,599	1/CHF	3.95	(US\$ 2.30)
1,600-3,199	1/CHF	3.80	(US\$ 2.21)
3,200	1/CHF	3.75	(US\$ 2.18)

CODE**PIS****E6/46****STOP!Watch
Refrigerator monitor, (0°C)****COMPANY NAME AND ADDRESS**

Berlinger & Co. AG

Postfach 67

9608 Ganterschwil

Switzerland

Telephone: 41 (71) 982 88 11*Fax:* 41 (71) 982 88 39*E-mail:* info@berlinger.ch**SPECIFICATIONS**

Temperature thresholds	0°C, +10 & +34°C
External dimensions	120x120 mm.
External materials	Card
Weight	2.3 kg.
Number per package	200

COMMENTS*Test Reports: Wolff Lab. (1988)**Meets WHO/UNICEF Standard E6/IN2 and IN3*

Function: This monitor carries two indicators: a strip "MonitorMark" which changes irreversibly from white to blue if exposed to temperatures higher than +10 and +34° C; and a FreezeWatch vial which bursts at temperatures below 0°C.

This model replaces E6/40, which is equipped with a Freeze Watch that bursts at -4.5°C. This change is due to the introduction of Hepatitis B, with a freezing point of -0.5°C, in the standard EPI schedule.

Use: For installation in vaccine refrigerators to continuously monitor the range of refrigerator temperatures.

Shelf life is three years.

2000 PRICES (EX WORKS)*Shipping volume (200 pcs)* 0.02 m³*Minimum order:* 400

Quantity/Price:	1/CHF	8.35 (US\$ 4.85)
------------------------	-------	------------------

CODE
PIS
E6/47

**Temperature data logger:
AUTOLOG 2000 TM**

COMPANY NAME AND ADDRESS

Remonsys Ltd.
Goss House, 26 High Street
Street, Somerset BA16 OEB
United Kingdom
Telephone: +44 (1458) 84 00 88
Fax: +44 (1458) 84 11 88
E-mail: lewis@autolog.u-net.com

SPECIFICATIONS

Temperature range -30°C to +70°C
Accuracy ± 0.1°C
Measuring interval 1 - 60 mins
Memory size 8K
Size (dxl) 195x100x43 mm.
External materials ABS plastic case
Weight 300g (without sensors)
1000g (with 4 sensors)
Number per package 1
Power source internal Lithium battery
Battery life available 10 years

COMMENTS

Test Report: USDA approved

No WHO/UNICEF Standard exists.

Use: Functions as a "reusable cold chain monitor" for use in vaccine refrigerators, shipments and cold chain studies. It displays and stores data which can be downloaded by special cable to the serial port of a PC computer with MS Windows supported software. Comes equipped with 4 sensors (2x 6m & 2x20m).

2000 PRICES (FOB)

Shipping weight/ volume (1 pc) 1.3kg/0.006m3

Item	Min. order.	Price/unit
AUTOLOG 2000	1	1/GB£ 600.00 (US\$ 937.50)
Software + cable	1	1/GB£ 100.00 (US\$ 156.25)

CODE
PIS
E6/48

**Temperature data logger
Thermo-Tracer**

COMPANY NAME AND ADDRESS

OCEASOFT
Cap Alpha, Avenue de l'europe, clapiers
34940 Montpellier Cedex 9
France
Telephone: +33 (4) 67 75 36 30
Fax: +33 (4) 67 75 30 10
E-mail: info@oceasoft.com

SPECIFICATIONS

Temperature range -40°C to +85°C
Accuracy ± 1°C
Measuring interval 1 – 255 mins
Memory size 2048 measurements
Size (dxl) 17.35x5.89 mm.
External materials stainless steel
Weight 3.30g
Number per package 1
Power source internal Lithium battery
Battery life available 5+ years or 1 million measurements

COMMENTS

Test Report: CEMAGREF et LCIE, 2000

No WHO/UNICEF Standard exists.

Use: Functions as a "reusable cold chain monitor" for use in vaccine refrigerators, shipments and cold chain studies. It displays and stores data which can be downloaded to PC computer with MS Windows supported software. Unlimited licence on software (only 1 software required per organisation).

2000 PRICES (FOB)

Shipping weight/ volume (1 pc) 1.0kg/0.002m3

Item	Min. order.	Price/unit
Software, cable, 10 loggers	1	US\$ 1,332.00
Logger	1	US\$ 24.00
Interface cable	1	US\$ 29.00
Portable controller	1	US\$ 142.00

Section E7

Accessories

1. Introduction

This section describes a wide range of cold chain and refrigerator accessories.

The specifications for voltage regulators for individual refrigerators and freezers were revised in 1988 following failures of these regulators in the field. Manufacturers accordingly upgraded and retested their equipment to meet the new standards. The specifications for voltage regulators have again been revised in 2000, as new products have become available.

Please refer to section E1, part 3 for detailed information on large voltage regulators for cold rooms.

CODE**PIS****E7/08****Surface level:
Model SM100****COMPANY NAME AND ADDRESS**

Johnson Level & Tool Manufacturing Co.
6333 West Donges Bay Road
Mequon, Wisconsin 53092-4456
United States of America
Telephone: 1 (262) 242 11 61
Fax: 1(262) 242 01 89
E-mail: jtl@johnsonlevel.com

SPECIFICATIONS

Number per package	100
Weight per package	2.268 kg.
External dimensions	44 mm. (diameter)
External materials	Plastic

COMMENTS*Test Report:* —*(No WHO/UNICEF Standard exists)*

The function of this surface level is to ensure that absorption refrigerators and freezers are standing level. Also available in small quantities from WHO/Geneva.

2000 PRICES (FOB)

<i>Shipping volume</i>	0.017 m ³
<i>Minimum order :</i>	1 000

Quantity/Price:	1/US\$ 0.72
------------------------	-------------

CODE**PIS****E7/10****Vaccine packaging tape****COMPANY NAME AND ADDRESS**

Papeteries Mertens Sprl.
Boulevard du Centenaire 5
1325 Dion-Valmont
Belgium
Telephone: 32 (10) 24 12 43;
Fax: 32 (10) 24 18 57
E-mail: p.mertens@interweb.be

SPECIFICATIONS

Width of tape	75 mm.
Length of tape per roll	66 metres
Type of tape	PVC plastic
Weight per roll	0.4 kg.

COMMENTS*Test Report:* —*(No WHO/UNICEF Standard exists)*

This tough PVC tape is ideal for sealing cold boxes or packages of vaccine. The text, "VACCINE URGENT" is printed in sequence the length of each roll in five languages: Arabic, Chinese, English, French and Spanish.

A tape dispenser is also available and, depending on destination and quantity ordered, the manu-facturer reserves the right to supply this item.

2000 PRICES (FOB)

<i>Shipping volume</i>	0.001 m ³
<i>Minimum order for tape</i>	10 rolls

Quantity	Price:	
1 roll	DEM	6.00 (US\$ 2.93)
1 dispenser	DEM	100.00 (US\$ 48.78)

CODE**PIS****E7/11****Voltage regulator for compression refrigerators: Model FF 500/4R****COMPANY NAME AND ADDRESS**

Advance Galatrek

Advance Park

Wrexham LL14 3YR

United Kingdom

Telephone: 44 (1978) 82 10 00

Fax: 44 (1978) 81 08 52

E-Mail : sales@aelgroup.co.uk

SPECIFICATIONS

Nominal voltage	220 V
Continuous power	500 VA
Frequency	50 Hz, Phase 1
Input voltage range	145-278 V
Output voltage range	198-255 V
Input connection	2 metre fly lead
Output connection	socket with plug**
Indicators on input	green neon
Indicators on output	red neon
External materials	Grey painted steel
Weight (unpacked)	10 kg.
External dimensions	153x167x355 mm.*
Number per package	1

COMMENTS*Test Report: CATR.A.92071 (1988)**Meets WHO/UNICEF Standard E7/VR.1*

Unit is fitted with a circuit breaker, as well as a 6-12minute delay cutout on input to protect against high/low voltage. Prices FCA UK, but do not cover wood crating.

2000 PRICES (FCA)Shipping volume 0.091 m³

Minimum order : 1

Quantity	1-25	GB£ 184.00	(US\$ 287.50)
	26-100	GB£ 164.00	(US\$ 256.25)
	101+	GB£ 144.00	(US\$ 225.00)

* External dimensions unpacked.

** When ordering, specify type required.

CODE**PIS****E7/12****Voltage regulator for absorption refrigerators: Model FF 500/PA****COMPANY NAME AND ADDRESS**

Advance Galatrek

Advance Park

Wrexham LL14 3YR

United Kingdom

Telephone: 44 (1978) 82 10 00

Fax: 44 (1978) 81 08 52

E-Mail : sales@aelgroup.co.uk

SPECIFICATIONS

Nominal voltage	220 V
Continuous power	500 W
Frequency	50 Hz, Phase 1
Input voltage range	145-278V(+26-34%)
Output voltage range	209-231V (+/- 5%)
Input connection	2 metre fly lead
Output connection	socket with plug**
Indicators on input	green neon
Indicators on output	red neon
External materials	Grey painted steel
Weight (unpacked)	8.5 kg.
External dimensions	153x167x355 mm.*
Number per package	1

COMMENTS*Test Report: CATR.A.92071 (1988). Meets**WHO/UNICEF Standard E7/VR.2*

Unit is fitted with a circuit breaker, as well as a 2-3minute delay cutout on input to protect against high/low voltage. Prices FCA UK, but do not cover wood crating.

2000 PRICES (FCA)Shipping volume 0.091 m³

Minimum order : 1

Quantity:	1-25	GB£ £184.00	(US\$ 250.00)
	26-100	GB£ 164.00	(US\$ 256.25)
	101+	GB£ 144.00	(US\$ 225.00)

* External dimensions unpacked.

** When ordering, specify type required.

CODE
PIS
E7/13

Fibreglass wick for kerosene burner

COMPANY NAME AND ADDRESS

Silver Trading Company Ltd.
7-15, Kita-Kamei-cho 2-chome
Yao City, Osaka 581
Japan
Telephone: 81 (729) 91 12 34
Fax: 81 (729) 93 72 77

SPECIFICATIONS

Weight per package * kg.
Number per package —
External dimensions * mm.
Materials Fibreglass

COMMENTS

Test Report: BSI 108 524 (1985)
(No WHO/UNICEF Standard exists)
This replacement wick is made of fibreglass. The manufacturer claims a 2-3 year working life. The wick is available in several sizes to fit the different burners with which it can be used, as indicated below.

2000 PRICES (FOB)

Shipping volume * m³
Minimum order 500 (specify model number)

For burner	Model No.	Price/unit
Kosmos 8	SWM-001UF	JPY 145.00 (US\$ 1.34)
Kosmos 10	SWM-002UF	JPY 155.00 (US\$ 1.44)
Aladdin 23E	SWT-231UF	JPY 340.00 (US\$ 3.15)
Aladdin 32	SWT-141UF	JPY 340.00 (US\$ 3.15)

* Dimensions, weight and shipping volume vary according to model.

CODE
PIS
E7/26

Refrigerator/freezer universal spare parts kits for RCFC-12 or R134A

COMPANY NAME AND ADDRESS

H. Jessen Jürgensen A/S
Tempovej 18-22
DK 2750 Ballerup
Denmark
Telephone: 45 (44) 66 06 00
Fax: 45 (44) 68 34 05
E-mail: info@hjj.dkl

SPECIFICATIONS

External dimensions 82x67x43 cm.
External materials (container) plywood

COMMENTS

Test Report: —
(No WHO/UNICEF Standard exists)
This kit exists in 2 versions: for appliances containing RCFC-12 or R134A.

Attention: parts from appliances with different cooling agents are not interchangeable.
These spare parts kits are available in 220 V or 115 V options, to be specified when ordering. They can be used for repairs on most compressor refrigerators and freezers found in the EPI cold chain. Packed in 3 non-reusable plywood boxes (each with the dimensions given above), the kits include spare parts for approximately 200 repairs and include compressors, electric parts, copper tubing, oil, etc.

2000 PRICES (FOB)

Shipping weight/vol (1 kit) 302 kg /0.708 m³
Minimum order: 1

Quantity/price (including packing):

1 kit for RCFC-12 or 134A DKK 29 250.00 (US\$ 3 571.43)

CODE**PIS****E7/37****Tool kit for RCW 42 range of refrigerators****COMPANY NAME AND ADDRESS**

Electrolux (Luxembourg) SARL
 14, op der Hei
 L-9809 Hosingen
 Luxembourg
Telephone: 352 920 731
Fax: 352 920 731 300
e-mail: Pascal.Vannier@notes.electrolux.lu

SPECIFICATIONS

Weight per package 11.00 kg.
Number per package 1
External dimensions 43x22.x30 cm.
External materials (container) leather case

COMMENTS*Test Report:* —*(No WHO/UNICEF Standard exists)*

This tool kit contains 16 items, one of which is an 81-part set of spare parts for refrigerators in the RCW42 E-EG-EK range. An amp/volt meter and an electronic control thermometer are also included.

Mfg code:	EK	292.8599.02
	EG	292.8599.00
	EKG	292.8599.01

2000 PRICES (FOB)

Shipping weight/vol (1 pce) 11 kg /0.03 m³
Minimum order : 1

Qty/Price	EK:	1/XEU	1 121.00	(US\$ 1 019.09)
	EG	1/XEU	1 060.00	(US\$ 963.64)
	EKG:	1/XEU	1 268.00	(US\$ 1 152.73)

CODE**PIS****E7/38****Mains voltage compensator for compr. refrig.: Model MVC-2W S1775****COMPANY NAME AND ADDRESS**

Claude Lyons Limited
 Brook Road,
 Waltham Cross, Herts EN8 7LR
 United Kingdom
Telephone: 44 (1992) 76 88 88
Fax: 44 (1992) 78 80 00
E-mail: info@claudelyons.co.uk

SPECIFICATIONS

Nominal voltage 220 V
Continuous power 0.5 KVA
Frequency 47-63 Hz
Input voltage range 144-277 V
Output voltage range 202-240 V
External dimensions 240x233x137 mm
External materials metal enclosure
Connections:
Input 1.9 m. long; 3 core, 1 mm² lead
Output 3 pin socket (UK style, square pin)
Indicators green (input on); yellow (output on)
Weight per package 7.8 kg
Number per package 1

COMMENTS*Test Report:* CATR.Z.9259 (1989)*Meets WHO/UNICEF Standard E7/VR.1*

Unit is fitted with a circuit breaker and a delay override button with a 6-12 minute delay cutout to protect against high/low voltage.

2000 PRICES (FOB)

Shipping volume (1 pce) 0.008 m³
Minimum order : 1

Quantity	Price/unit		
1-25	GB£	242.00	(US\$ 378.13)
26-100	GB£	210.00	(US\$ 328.13)
100+	Consult manufacturer		

CODE
PIS
E7/39

**Mains voltage compensator for
absorp. refrig.: Model MVC-IN S1776**

COMPANY NAME AND ADDRESS

Claude Lyons Limited
Brook Road,
Waltham Cross, Herts EN8 7LR
United Kingdom
Telephone: 44 (1992) 76 88 88
Fax: 44 (1992) 78 80 00
E-mail: info@claudelyons.co.uk

SPECIFICATIONS

Nominal voltage	220 V
Continuous power	0.5 KVA
Frequency	50 Hz
Input voltage range	145-278 V
Output voltage range	210-234 V
External dimensions	240x233x137 mm
External materials	metal enclosure
Connections:	
Input	2.68 m. long; 3 core, 1 mm ² lead
Output	3 pin socket (UK style, square pin)
Indicators	green (input on); yellow (output on)
Number per package	1
Weight per package	7.8 kg

COMMENTS

Test Report: CATR.Z.9259 (1989)
Meets WHO/UNICEF Standard E7/VR.2
Unit is fitted with a circuit breaker and a delay over-ride button with a 2-3 minute delay cutout to protect against high/low voltage. Supplied with detailed manual with circuit diagrams and pre-sale test report.

2000 PRICES (FOB)

Shipping weight/vol (1 pce) 7.8 kg/0.008 m³
Minimum order : 1

Quantity	Price/unit
1-25	GB£ 236.00 (US\$ 368.75)
26-100	GB£ 205.00 (US\$ 320.31)
100+	Consult manufacturer

CODE
PIS
E7/42

**Gas conversion kit for RCW 42 EK/CF
refrig. & freezer: Model no. 991.1861.01/2**

COMPANY NAME AND ADDRESS

Electrolux (Luxembourg) SARL
14, op der Hei
L-9809 Hosingen
Luxembourg
Telephone: 352 920 731
Fax: 352 920 731 300
e-mail: Pascal.Vannier@notes.electrolux.lu

SPECIFICATIONS

Number per package	1
External dimensions	27x14x8 cm.

COMMENTS

Test Report: —
(No WHO/UNICEF Standard exists)
Kit to convert RCW 42 EK refrigerator from kerosene to gas operation.
Please specify gas bottle pressure when ordering this kit.

2000 PRICES (FOB)

Shipping weight/vol (1 pce) 1.2 kg /0.003 m³
Minimum order : 1

Quantity/Price: 1/XEU 61.00 (US\$ 55.45)

CODE**PIS****E7/43****Manual gas changeover valve:
Model 02 060-00 (prop. & butane gas)****COMPANY NAME AND ADDRESS**GOK Regler- und Armaturen-Gesellschaft Mbh & Co.
KGObernbreiter Strasse 4, D-97340 Marktbreit/Main
Federal Republic of Germany

Telephone: 49 (9332) 404 69

Fax: 49 (9332) 404 49

E-mail: info@gok-online.de

SPECIFICATIONS

Capacity	0.8 kg per hour
Weight	1.295 kg
Number per package	1

COMMENTS*Test Report: ---**(No WHO/UNICEF Standard exists)*

This valve connects two gas cylinders, of 3kg each.

When one cylinder is empty there needs to be a manual changeover to the second in order to ensure a continuous gas supply.

Order 50 mbar for butane and propane.

2000 PRICES (FOB)Shipping volume -- m³

Minimum order : 1

Quantity/Price 1/DEM 245.00 (US\$ 119.51)**CODE****PIS****E7/44****Upgrade kit for RCW 42 EK/CF freezer
and refrigerator: Model no. 991.1860.01****COMPANY NAME AND ADDRESS**

Electrolux (Luxembourg) SARL

14, op der Hei

L-9809 Hosingen

Luxembourg

Telephone: 352 920 731

Fax: 352 920 731 300

e-mail: Pascal.Vannier@notes.electrolux.lu

SPECIFICATIONS

Weight per package	1 kg.
Number per package	1
External dimensions	55x28x14 mm.

COMMENTS*Test Report: —**(No WHO/UNICEF Standard exists)*

This kit is for upgrading Electrolux RCW42 EK refrigerators to operate with the burner modification kit. Consists of:

- 1 Kosmos 8 burner
- 1 kerosene tank
- 1 heat shield for the tank
- 1 heat corner shield
- 1 metal lamp glass
- 1 mesh ring kit
- 1 insert for lamp glass
- 1 poster
- 1 User's Instruction Booklet

2000 PRICES (FOT Luxembourg)Shipping weight/vol (1 pce) 1 kg /0.021 m³

Minimum order : 1

Quantity/Price: 1/XEU 201.00 (US\$ 182.73)

CODE
PIS
E7/51

Modification kit to upgrade domestic refrigerators for vaccine storage

COMPANY NAME AND ADDRESS

Universidad del Valle (UNIVALLE)
Laboratorio de Ciencias Térmicas
Apartado Aereo 25360
Cali, Colombia
Telephone: 57 (92) 321 21 37
Fax: 57 (92) 339 72 64
E-Mail: camamb@mafalda.univalle.edu.co
gcbreira@mafalda.univalle.edu.co

SPECIFICATIONS

Weight per package	13.0 kg
Number per package	1
External dimensions	125 x 25 x 65 mm.
Materials (container)	Corr. cardb. box
Materials (kit)	Aluminium

CONTENTS OF THE KIT

The kit contains a complete set of materials, and an instruction manual, to upgrade a domestic refrigerator for vaccine storage. It includes:

Aluminium sheet, thickness 0.6mm; 3 x 1 metre ²	1
Perforated plastic grid for shelves (1.2x0.6x0.01m)	1
Polystyrene sheets	5
Vertical hanging vaccine thermometer (E6/08)	1
Icepacks	35
Instruction manual	1
Miscellaneous (fittings, etc.)	1

COMMENTS

Test Report: Univalle report (November 1993); Field tests, Univalle (February 1995). (No WHO/UNICEF Standard exists).

This kit raises the performance of domestic refrigerators to meet WHO/UNICEF requirements for vaccine storage. It can be used with all types of domestic refrigerators and installation is simple. Document WHO/EPI/LHIS/94.4, available from WHO/EPI/Geneva, describes the design and methodology of the kit. The instruction manual shows how to assemble a closed container, with a front door.

2000 PRICES (FOB)

Shipping weight/vol (1 pack) 13 kg/0.27 m³
Minimum order: 1

Price of complete kit: US\$ 100.00 (Std. thermometer)
US\$ 117.00 (Digit. thermom.)

CODE
PIS
E7/52

Cotton wicks for kerosene burners

COMPANY NAME AND ADDRESS

Aladdin Sales and Marketing Limited
6 Grovelands Business Centre
Boundary Way, Hemel Hempstead
Herts HP2 7TE
United Kingdom
Telephone: 44 (1442) 23 58 58
Fax: 44 (1442) 23 57 60
E-mail: Sales@aladdineurope.co.uk

SPECIFICATIONS

Wick for Aladdin 23E burner

Refrigerator type	V 170 KE (E3/84-M)
Length	210 mm
Material	Cotton
Shipping weight	23 g

Wick for Aladdin 32 burner

Refrigerator type	FCW20 EK (E3/73-M)
Length	210 mm
Material	Cotton
Shipping weight (1 pce)	12 g
(carton 600 pcs)	7.8 kg

Wick for Kosmos 8 burner

Refrigerator type	RCW42 EK (E3/22-M)
Length	250 mm
Material	Cotton
Shipping weight (1 pce)	7 g

COMMENTS

(No WHO/UNICEF Standard exists)

Consult manufacturer for selection of wicks available for several lengths and sizes for a variety of models.

2000 PRICES (EX WORKS)

Minimum order GB£ 1,500.00. Surcharge for lower orders.

For burner	Code	Price/unit
Aladdin 23E	P.239936	GB£ 1.55 (US\$ 2.42)
Aladdin 32	P.990820	GB£ 1.43 (US\$ 2.23)
Cosmos 8	p.960618	GB£ 0.67 (US\$ 1.05)

CODE**PIS****E7/54****Basic tool kit for refrigerator technician for CFC-12 and HFC-134A systems, 220V******COMPANY NAME AND ADDRESS**

Vestfrost A/S
 P. O. Box 2079
 Spangsbjerg Mollevej 100
 DK 6705 Esbjerg 0, Denmark
Telephone: 45 (79) 14 22 22
Fax: 45 (79) 14 23 55
Telex: export@vestfrost.dk

SPECIFICATIONS

Weight per kit 65.0 kg.
External dimensions 90x90x90 mm.
External materials (containers) Painted steel

CONTENTS OF THE KIT

Measuring instruments common to CFC-12 and HFC-134a kits

1. Digital multimeter with case	1
2. Electronic leak detector (CFC-12, HFC-134a)	1
3. Electronic thermometer with 1.5 m phial	1
4. Vernier Caliper	1
5. Measuring tape 2m	1

List of Tools common to CFC-12 and HFC-134a kits

6. Set of hexagon socket spanners (Allen keys)	1
7. Adjustable spanner 6" - Bacho	1
8. Adjustable spanner 4" - Bacho	1
9. Electrician insulated crimping tool	1
10. Multigrip pliers	1
11. Needle Nose Pliers (Pointed pliers) - Knipex	1
12. Cutting pliers - Bacho	1
13. Ratchet	1
14. Handle for assorted bits	1
15. box of assorted bits	1
16. Screw driver ordinary slot - Bacho	1
17. Screw driver, cross head - Bacho	1
18. Flate fine file with handle, 150 mm	1
19. Round file with handle, 150 mm	1
20. Steel brushes	3
21. Saw, small with blades	1
22. Ordinary Hammer	1
23. Plastic hammer	1
24. Protection glasses	1
25. Allan key for cap (pressure cylinder, dry Nitrogen 2 liters)	1
26. Dentist mirror	1

List of General Items common to CFC-12 and HFC-134a Kits

27. Wooden transport box with handles and lock	1
28. Lokring Tube Connector Kit (Lokring bag)	1

29. Leather Tool bag with lock and keys	1
30. Nitrogen purging set. (Pressure cylinder, dry Nitrogen 2 liters)	1
31. Service manuals (GB)	2
32. Video and text - VHS PAL	2

COMMENTS

Test Report: — (No WHO/UNICEF Standard exists)

For use in training courses and in the field, this kit includes both tools and consumables. As a basic kit, it contains tools common to both CFC-12 and HFC-134A refrigerating systems for the repair of compression refrigerators and freezers.

Technicians maintaining CFC-12 and HFC-134a equipment also require:

E7/55 or E7/59 for CFC-12 systems **only** and
 E7/56 or E7/60 for HFC-134A systems **only**.

Tools are packed in a wooden hinged box with handle and lock.

2000 PRICES (FOB)

Shipping weight/vol (1 kit) 65 kg / 0.729 m³
Minimum order 1 kit

Quantity/price (including packing):

1 Toolkit XEU 1 419.40 (US\$ 1 290.36)

** This toolkit replaces E7/47. In order to meet the needs of the two refrigerating systems, CFC-12 and HFC-134A, and the introduction of CFC equipment the kit has been split into 4 separate kits: a basic set of tools common to both systems, a supplementary kit for each system, and a Lokring service kit.*

***Two options of this kit are available:*

Option 1: For use with electricity supply 220-240 V.

Option 2: For use with electricity supply: 110-115V.

CODE**PIS****E7/55****Supplementary refrigerator toolkit for CFC-12 systems only****COMPANY NAME AND ADDRESS**

Vestfrost A/S
 P. O. Box 2079
 Spangsbjerg Mollevej 100
 DK 6705 Esbjerg 0, Denmark
Telephone: 45 (79) 14 22 22
Fax: 45 (79) 14 23 55
Telex: export@vestfrost.dk

SPECIFICATIONS

Weight per kit 78 kg.
External dimensions 90x90x90 cm.
External materials (containers) Painted steel

CONTENTS OF THE KIT

1. Process tongs Pinch off tool	1
2. Piercing pliers -(Drilling tongs)	2
3. Piercing pliers tools adapters	6
4. Capillary tube shears	1
5. Tool for Deburring	1
6. Tube cutter	1
7. Scrader valve remover	1
8. Refrigerant collection bag for CFC-12	2
9. Recovery and recycling unit CFC-12	1
10. Charging unit CFC-12 with abs vacuum gauge and protective solenoid valve	1
11. Protective cap for Nitrogen pressure cylinder	1
12. Vessel (Cylinder) for used refrigerant, 1/2" flare	1
13. Instruction for Charging unit CFC-12	1
14. Filter dryers	10
15. Tool Bag for CFC-12 specific tools	1
Spares for CFC-12 Refrigeration tools	
16. Emery paper	1
17. Gaskets for piercing pliers (drilling tongs)	2
18. Extra wheel for pipe cutter	1
19. Process tubes 6mm, lenght 400mm	10
20. Piercing needle for piercing pliers (needle for drilling tongues)	1

COMMENTS

Test Report: —
 (No WHO/UNICEF Standard exists)
 For a full CFC-12 tool kit, order also Basic Repair Toolkit E7/54 or E7/58
 Tools are packed in a wooden hinged box with handle and lock.

2000 PRICES (FOB)

Shipping weight/vol (1 kit) 78 kg / 0.729 m³
Minimum order 1 kit

Quantity/price (including packaging):

1 Toolkit XEU 2 034.94 (US\$ 1 849.95)

CODE**PIS****E7/56****COMMENTS**

Test Report: — (No WHO/UNICEF Standard exists)
 For a full HFC-134A tool kit, order also Basic Repair Toolkit E7/54 or E7/58.

2000 PRICES (FOB)

Shipping weight/vol (1 kit) 78 kg / 0.729 m³
Minimum order 1 kit

Quantity/price (including packaging):

1 Toolkit XEU 2 072.02 (US\$ 1 883.65)

Supplementary refrigerator toolkit for HFC-134A systems only

COMPANY NAME AND ADDRESS

Vestfrost A/S
 P. O. Box 2079
 Spangsbjerg Mollevej 100
 DK 6705 Esbjerg 0, Denmark
Telephone: 45 (79) 14 22 22
Fax: 45 (79) 14 23 55
 Telex: export@vestfrost.dk

SPECIFICATIONS

Weight per kit 25 kg
External dimensions 640x230x230 mm.
External materials (toolbox) Painted steel

CONTENTS OF THE KIT

1. Process tongs Pinch off tool	1
2. Piercing pliers -(Drilling tongs)	2
3. Piercing pliers tools adapters	6
4. Capillary tube shears	1
5. Tool for Deburring	1
6. Tube cutter	1
7. Scrader valve remover	1
8. Valve for disposable bottle for 134a	1
9. Refrigerant collection bag for HFC-134a	2
10. Recovery and recycling unit HFC- 134a	1
11. Charging unit HFC-134a with abs vacuum gauge and protective solenoid valve	1
12. Protective cap for Nitrogen pressure cylinder	1
13. Refrigerant 134a, 950 g.	1
14. Vessel (Cylinder) for used refrigerant, 1/2" flare	1
15. Instruction for Charging unit HFC-134a	1
16. Filter dryers	10
17. Tool Bag for HFC-134a specific tools	1
Spares for HFC-134a Refrigeration tools	
18. Emery paper	1
19. Gaskets for piercing pliers (drilling tongs)	2
20. Extra wheel for pipe cutter	1
21. Process tubes 6mm, lenght 400mm	10
22. Piercing needle for piercing pliers (needle for drilling tongues)	1

CODE**PIS****E7/57****Complete refrigerator Lokring kit
AKK110****COMPANY NAME AND ADDRESS**

Vestfrost A/S
 P. O. Box 2079
 Spangsbjerg Mollevej 100
 DK 6705 Esbjerg 0, Denmark
 Telephone: 45 (79) 14 22 22
 Fax: 45 (79) 14 23 55
 Telex: export@vestfrost.dk

SPECIFICATIONS

Weight per kit 25 kg
External dimensions 640x230x230 mm.
External materials (toolbox) Painted steel

CONTENTS OF THE KIT

LOCKRING TYPE & SIZE

Brass Union Joints	
1. 2 NK Ms 00	4
2. 5 NK Ms 00	10
3. 6 NK Ms 00	5
4. 7,5 NK Ms 00	2
5. 8 NK Ms 00	2
Brass Reduced Union joints	
6. 3/2 NR Ms 00	2
7. 4/2 NR Ms 00	2
8. 5/2 NR Ms 00	15
9. 5/4 NR Ms 00	2
10. 6/2 NR Ms 00	5
11. 6/2,5 NR Ms 00	6
12. 6/5 NR Ms 00	5
13. 7/5 NR Ms 00	5
14. 7,5/6 NR Ms 00	2
15. 7/6 NR Ms 00	2
16. 8/2 NR Ms 00	5
17. 8/2,2 NR Ms 00	5
18. 8/2,5 NR Ms 00	5
19. 8/5 NR Ms 00	3
20. 8/6 NR Ms 00	10
21. 8/7 NR Ms 00	2
22. 8/7,5 NR Ms 00	2
23. 9,53/5 NR Ms 00	2
24. 9,53/6 NR Ms 00	6
25. 9,53/8 NR Ms 00	2
26. 9,53/9 NR Ms 00	1
27. 10/8 NR Ms 00	1
28. 11/6 NR Ms00	1
29. 11/8 NR Ms 00	1
Aluminum Union Joints	
30. 5 NK Al 00 *	3
31. 6 NK Al 00 *	2

32. 7,5 NK Al 00	2
33. 8 NK Al 00	1
Aluminum Reduced Union joints	
34. 6/5 NR Al 00 *	2
35. 7/5 NR Al 00 *	2
36. 7/6 NR Al 00 *	1
37. 8/6 NR Al 00 *	1
38. 8/7 NR Al 00	1
39. 8/7,5 NR Al 00	5
40. 9/8 NR Al 00	1
Union Joints with Schrader Valve	
41. 6 NK Ms SV *	3
42. 8 NK Ms SV	2
Reduced Union Joints with Schrader Valve	
43. 8/6 NR Ms SV *	2
44. 8/7,5 NR Ms SV	1
45. 9,53/6 NR Ms SV	2
46. 7/6,2 NTR Ms 00	1
47. 7,5/6,2 NTR Ms 00	1
48. 8/6,2 NTR Ms 00	1
Stopper	
49. 6 VS Ms 00 *	8
50. 8 VS Ms 00	2
Accessories	
51. Aluminum case with sections	1
52. Hand tool HMRK - L8	1
53. Assembly jaws MB 10	2
54. NTR Insert for assembly tool	1
55. Bottle LOCKPREP	1
Filling Tube with Schrader Valve	
56. 6 NF Ms SV	5

COMMENTS

Test Report: — (No WHO/UNICEF Standard exists)

2000 PRICES (FOB)

Shipping weight/vol (1 kit) 25 kg/0.087 m³
Minimum order 1 kit

Quantity/price (including packaging):

1 Toolkit XEU 594.50 (US\$ 540.45)

CODE**PIS****E7/58****Basic tool kit for refrigerator technician for CFC-12 and HFC-134A systems, 220V******COMPANY NAME AND ADDRESS**

H. Jessen Jürgensen A/S
Tempovej 18-22
DK 2750 Ballerup
Denmark

Telephone: 45 (44) 66 06 00
Fax: 45 (44) 68 34 05
E-mail: info@hjj.dkl

SPECIFICATIONS

Weight per kit 65.0 kg.
External dimensions 90x90x90 mm.
External materials (containers) Painted steel

**Two options of this kit are available:

Option 1: For use with electricity supply 220-240 V.

Option 2: For use with electricity supply: 110-115V

CONTENTS OF THE KIT

Measuring instruments common to CFC-12 and HFC-134a kits

1. Digital multimeter with case	1
2. Electronic leak detector (CFC-12, HFC-134a)	1
3. Electronic thermometer with 1.5 m phial	1
4. Vernier Caliper	1
5. Measuring tape 2m	1

List of Tools common to CFC-12 and HFC-134a kits

6. Set of hexagon socket spanners (Allen keys)	1
7. Adjustable spanner 6" - Bacho	1
8. Adjustable spanner 4" - Bacho	1
9. Electrician insulated crimping tool	1
10. Multigrip pliers	1
11. Needle Nose Pliers (Pointed pliers) - Knipex	1
12. Cutting pliers - Bacho	1
13. Ratchet	1
14. Handle for assorted bits	1
15. box of assorted bits	1
16. Screw driver ordinary slot - Bacho	1
17. Screw driver, cross head - Bacho	1
18. Flate fine file with handle, 150 mm	1
19. Round file with handle, 150 mm	1
20. Steel brushes	3
21. Saw, small with blades	1
22. Ordinary Hammer	1
23. Plastic hammer	1
24. Protection glasses	1
25. Allan key for cap (pressure cylinder, dry Nitrogen 2 liters)	1
26. Dentist mirror	1

List of General Items common to CFC-12 and HFC-134a Kits

27. Wooden transport box with handles and lock	1
28. Lokring Tube Connector Kit (Lokring bag)	1
29. Leather Tool bag with lock and keys	1
30. Nitrogen purging set. (Pressure cylinder, dry Nitrogen 2 liters)	1
31. Service manuals (GB)	2
32. Video and text - VHS PAL	2

COMMENTS

Test Report: — (No WHO/UNICEF Standard exists)

For use in training courses and in the field, this kit includes both tools and consumables. As a basic kit, it contains tools common to both CFC-12 and HFC-134A refrigerating systems for the repair of compression refrigerators and freezers.

Technicians maintaining CFC-12 and HFC-134a equipment also require:

E7/55 or E7/59 for CFC-12 systems **only** and

E7/56 or E7/60 for HFC-134A systems **only**.

Tools are packed in a wooden hinged box with handle and lock.

2000 PRICES (FOB)

Shipping weight/vol (1 kit) 65 kg / 0.729 m³
Minimum order 1 kit

Quantity/price (including packing):

1 Toolkit DKK 9 675.00 (US\$ 1 181.32)

** This toolkit replaces E7/47. In order to meet the needs of the two refrigerating systems, CFC-12 and HFC-134A, since the introduction of CFC free equipment the kit has been split into 4 separate kits: a basic set of tools common to both systems, a supplementary kit for each system, and a Lokring service kit.*

CODE**PIS****E7/59****Supplementary refrigerator toolkit for CFC-12 systems only****COMPANY NAME AND ADDRESS**

H. Jessen Jürgensen A/S

Tempovej 18-22

DK 2750 Ballerup

Denmark

Telephone: 45 (44) 66 06 00

Fax: 45 (44) 68 34 05

E-mail: info@hjj.dkl

SPECIFICATIONS

Weight per kit	78 kg.
External dimensions	90x90x90 cm.
External materials (containers)	Painted steel

CONTENTS OF THE KIT

1. Process tongs Pinch off tool	1
2. Piercing pliers - (Drilling tongs)	2
3. Piercing pliers tools adapters	6
4. Capillary tube shears	1
5. Tool for Deburring	1
6. Tube cutter	1
7. Scrader valve remover	1
8. Refrigerant collection bag for CFC-12	2
9. Recovery and recycling unit CFC-12	1
10. Charging unit CFC-12 with abs vacuum gauge and protective solenoid valve	1
11. Protective cap for Nitrogen pressure cylinder	1
12. Vessel (Cylinder) for used refrigerant, 1/2" flare	1
13. Instruction for Charging unit CFC-12	1
14. Filter dryers	10
15. Tool Bag for CFC-12 specific tools	1
Spares for CFC-12 Refrigeration tools	
16. Emery paper	1
17. Gaskets for piercing pliers (drilling tongs)	2
18. Extra wheel for pipe cutter	1
19. Process tubes 6mm, length 400mm	10
20. Piercing needle for piercing pliers (needle for drilling tongues)	1

COMMENTS*Test Report: —**(No WHO/UNICEF Standard exists)*

For a full CFC-12 tool kit, order also Basic Repair Toolkit E7/54 or E7/58

Tools are packed in a wooden hinged box with handle and lock.

2000 PRICES (FOB)Shipping weight/vol (1 kit) 78 kg / 0.729 m³

Minimum order 1 kit

Quantity/price (including packaging):**1 Toolkit** DKK 15 925.00 (US\$ 1 944.44)

CODE**PIS****E7/60****Supplementary refrigerator toolkit for HFC-134A systems only****COMPANY NAME AND ADDRESS**

H. Jessen Jürgensen A/S

Tempovej 18-22

DK 2750 Ballerup

Denmark

Telephone: 45 (44) 66 06 00*Fax:* 45 (44) 68 34 05*E-mail:* info@hjj.dkl**SPECIFICATIONS**

Weight per kit	25 kg
External dimensions	640x230x230 mm.
External materials (toolbox)	Painted steel

CONTENTS OF THE KIT

1. Process tongs Pinch off tool	1
2. Piercing pliers -(Drilling tongs)	2
3. Piercing pliers tools adapters	6
4. Capillary tube shears	1
5. Tool for Deburring	1
6. Tube cutter	1
7. Scrader valve remover	1
8. Valve for disposable bottle for 134a	1
9. Refrigerant collection bag for HFC-134a	2
10. Recovery and recycling unit HFC-134a	1
11. Charging unit HFC-134a with abs vacuum gauge and protective solenoid valve	1
12. Protective cap for Nitrogen pressure cylinder	1
13. Refrigerant 134a, 950 g.	1
14. Vessel (Cylinder) for used refrigerant, 1/2" flare	1
15. Instruction for Charging unit HFC-134a	1
16. Filter dryers	10
17. Tool Bag for HFC-134a specific tools	1
18. Spares for HFC-134a Refrigeration tools	
19. Emery paper	1
20. Gaskets for piercing pliers (drilling tongs)	2
21. Extra wheel for pipe cutter	1
22. Process tubes 6mm, lenght 400mm	10
23. Piercing needle for piercing pliers	1
24. (needle for drilling tongues)	
25.	

COMMENTS

Test Report: — (No WHO/UNICEF Standard exists)
 For a full HFC-134A tool kit, order also Basic Repair Toolkit E7/54 or E7/58.
 Tools are packed in a wooden hinged box with handle and lock.

2000 PRICES (FOB)

Shipping weight/vol (1 kit) 78 kg / 0.729 m³
Minimum order 1 kit

Quantity/price (including packaging):

1 Toolkit DKK 15 925.00 (US\$ 1 944.44)

CODE**PIS****E7/61****Complete refrigerator Lokring kit
AKK110****COMPANY NAME AND ADDRESS**

H. Jessen Jürgensen A/S

Tempovej 18-22

DK 2750 Ballerup

Denmark

Telephone: 45 (44) 66 06 00

Fax: 45 (44) 68 34 05

E-mail: info@hjj.dk

SPECIFICATIONS

Weight per kit	25 kg
External dimensions	640x230x230 mm.
External materials (toolbox)	Painted steel

CONTENTS OF THE KIT

LOCKRING TYPE & SIZE

Brass Union Joints

1. 2 NK Ms 00	4
2. 5 NK Ms 00	10
3. 6 NK Ms 00	5
4. 7,5 NK Ms 00	2
5. 8 NK Ms 00	2

Brass Reduced Union joints

6. 3/2 NR Ms 00	2
7. 4/2 NR Ms 00	2
8. 5/2 NR Ms 00	15
9. 5/4 NR Ms 00	2
10. 6/2 NR Ms 00	5
11. 6/2,5 NR Ms 00	6
12. 6/5 NR Ms 00	5
13. 7/5 NR Ms 00	5
14. 7,5/6 NR Ms 00	2
15. 7/6 NR Ms 00	2
16. 8/2 NR Ms 00	5
17. 8/2,2 NR Ms 00	5
18. 8/2,5 NR Ms 00	5
19. 8/5 NR Ms 00	3
20. 8/6 NR Ms 00	10
21. 8/7 NR Ms 00	2
22. 8/7,5 NR Ms 00	2
23. 9,53/5 NR Ms 00	2
24. 9,53/6 NR Ms 00	6
25. 9,53/8 NR Ms 00	2
26. 9,53/9 NR Ms 00	1
27. 10/8 NR Ms 00	1
28. 11/6 NR Ms 00	1
29. 11/8 NR Ms 00	1

Aluminum Union Joints

30. 5 NK Al 00 *	3
31. 6 NK Al 00 *	2
32. 7,5 NK Al 00	2
33. 8 NK Al 00	1

Aluminum Reduced Union joints

34. 6/5 NR Al 00 *	2
35. 7/5 NR Al 00 *	2
36. 7/6 NR Al 00 *	1
37. 8/6 NR Al 00 *	1
38. 8/7 NR Al 00	1
39. 8/7,5 NR Al 00	5
40. 9/8 NR Al 00	1

Union Joints with Schrader Valve

41. 6 NK Ms SV *	3
42. 8 NK Ms SV	2

Reduced Union Joints with Schrader Valve

43. 8/6 NR Ms SV *	2
44. 8/7,5 NR Ms SV	1
45. 9,53/6 NR Ms SV	2
46. 7/6,2 NTR Ms 00	1
47. 7,5/6,2 NTR Ms 00	1
48. 8/6,2 NTR Ms 00	1

Stopper

49. 6 VS Ms 00 *	8
50. 8 VS Ms 00	2

Accessories

51. Aluminum case with sections	1
52. Hand tool HMRK - L8	1
53. Assembly jaws MB 10	2
54. NTR Insert for assembly tool	1
55. Bottle LOCKPREP	1

Filling Tube with Schrader Valve

56. 6 NF Ms SV	5
----------------	---

COMMENTS*Test Report: — (No WHO/UNICEF Standard exists)***2000 PRICES (FOB)***Shipping weight/vol (1 kit) 25 kg/0.087 m³**Minimum order 1 kit***Quantity/price (including packaging):****1 Toolkit DKK 4 675.00 (US\$ 570.82)**

Section E8

Equipment admin.

WARNING

Readers should note that PIS pages are **NO LONGER VALID** for the following categories due to the introduction of the PQS system:

PIS E08 Injection devices since 30 June 2005
PIS E06 Temperature monitoring devices since 1 October 2007

All items that appear in PIS 2000 Edition WHON&B/00.13 sections E08 and E06 along with all items listed in WHO web site http://www.who.int/immunization_standards/vaccine_quality/new_sheets_intro/en/index.html under E06 category are no longer recommended by the WHO.

Readers should consult the following pages for PQS prequalified devices and equipment for E06 and E08 categories:

http://www.who.int/immunization_standards/vaccine_quality/pqs_prequalified_devices_e08/en/index.html
http://www.who.int/immunization_standards/vaccine_quality/pqs_prequalified_devices_e06/en/index.html

1. Injection equipment

The syringes listed in this section are used to administer vaccines in the EPI.

An injection should only be given if it is necessary — and every injection given must be safe.

- An injection for immunization is necessary (with the exception of oral vaccines).
- An immunization injection is safe when the vaccine is injected using the appropriate equipment and according to the recommended procedures for injection, sterilization and disposal.

The proper techniques for the administration of immunization injections have been specified in a document.¹

The following equipment may be used to administer injectable vaccines:

- Auto-disable syringes with fixed needles or removable needles (with a non-standard luer hub)
- Sterilizable syringes and needles
- Needle-less jet injectors

The following additional equipment is necessary to ensure safety:

- Safety boxes for the collection of used syringes, needles and sharps
- Steam sterilizers used with TST indicators to confirm completion of the sterilization cycle
- Needle destroyers and safety boxes
- Incinerators for final disposal of used injection equipment

The equipment is safe only if users strictly follow the procedures specified for its use.¹

¹ *Immunization in practice*. Geneva, World Health Organization. WHO/EPI/TRAM/98.01-11 Rev.1 (available on request from the Document Centre, Vaccines and Biologicals, World Health Organization, 1211 Geneva 27, Switzerland).

¹ *Safety of injections in immunization programmes: WHO recommended policy. Draft: Revision October 1998*. Geneva, World Health Organization, 1998 (unpublished document WHO/EPI/LHIS/96.05 Rev.1 sections 2–4; available on request from the Document Centre, Vaccines and Biologicals, World Health Organization, 1211 Geneva 27, Switzerland).

1.1 Auto-disable (AD) syringes with fixed needles

The auto-disable¹ syringe is the preferred type of disposable equipment for the administration of vaccines in both routine and mass immunization programmes. The auto-disable syringe carries the lowest risk of person-to-person transmission of bloodborne pathogens because it cannot be reused.²

Note: The auto-disable syringes listed in this section are those which meet the WHO specifications for use in the EPI and have been used extensively in immunization programmes. Another syringe (P8/01) is listed in section P of this catalogue because it is designed for 2-ml injections as used in other primary healthcare care activities.

1.2 Sterilizable syringes

Sterilizable syringes may be used for routine immunization sessions where compliance with cleaning and sterilization procedures between each use can be ensured, as verified by supervisory visits and by routine use of spot checks of “time, steam and temperature” (TST).

Sterilizable syringes are neither practical nor economical for mass immunization sessions and **should not be used for this purpose.**

1.3 Jet injectors

It is current WHO policy that jet injectors can be used only if laboratory tests show that they do not carry a risk of contamination. At present there are no models that meet this specification.

WHO recommends that only jet injectors that meet WHO specifications be used.

1.4 Standard disposable syringes (not listed in the *Product information sheets*)

Standard disposable syringes and needles should not be used for immunization purposes because it cannot be guaranteed that they will be destroyed after a single use. This type of syringe cannot be bought through UNICEF for immunization purposes.

There is clear evidence that reuse of disposable syringes is widespread globally. WHO warns governments and donor agencies that the reuse of standard disposable syringes and needles places the general public at high risk of disease and death.

¹ Meeting WHO/EPI Standard Performance Specification E8/DS1.

² *Safety of injections: WHO-UNICEF-UNFPA joint statement on the use of auto-disable syringes in immunization services.* Geneva, World Health Organization, 1999. WHO/V&B/99.25 (available on request from the Document Centre, Vaccines and Biologicals, World Health Organization, 1211 Geneva 27, Switzerland).

2. Disposal of injection equipment

2.1 Safety boxes for the disposal of used syringes, needles and sharps (listed in section E 12)

Puncture-resistant containers for the collection and disposal of used disposable and auto-disable syringes, needles and other injection materials must be provided and used in all immunization activities. These containers reduce the risk posed by contaminated needles and syringes both to health staff and the general population.

2.2 Incineration equipment (see the introduction to section E12)

Auto-combustion type incinerators, which achieve temperatures in excess of 800°C, are recommended for the destruction of all contaminated sharps, including syringes and needles used for immunization. This equipment ensures the most complete destruction of used sharps while also causing minimal environmental pollution.

3. Injection safety

Further information and the WHO recommendations on the choice and use of syringes, needles, sterilizers and other injection equipment is available from WHO.^{1,2,3}

¹ *Safety of injections in immunization programmes, WHO recommended policy.* Geneva, World Health Organization, 1998 (unpublished document WHO/EPI/LHIS/96.05 sections 2–4; available on request from the Document Centre, Vaccines and Biologicals, World Health Organization, 1211 Geneva 27, Switzerland).

² *Reducing the risk of unsafe injections in immunization programmes; the financial and operational implications of using various injection technologies.* Geneva, World Health Organization, 1998 (unpublished document WHO/EPI/LHIS/94.02; available on request from the Document Centre, Vaccines and Biologicals, World Health Organization, 1211 Geneva 27, Switzerland).

³ *Ensuring safe injections, Module 5. Immunization in practice series, revised.* Geneva, World Health Organization, 1998. WHO/EPI/TRAM/98.01-11 Rev.1 (available on request from the Document Centre, Vaccines and Biologicals, World Health Organization, 1211 Geneva 27, Switzerland).

CODE
PIS
E8/01

Sterilizable plastic syringe, 0.05 ml

COMPANY NAME AND ADDRESS

CODAN Medical ApS
Faergevej 4
DK-4970 Roedby
Denmark
Telephone: 45 (54) 65 74 11
Fax: 45 (54) 60 51 01
E-mail: medical@codan.de

SPECIFICATIONS

Vaccine capacity	0.05 ml.
Graduations	0/0.05
Material of the syringe	Polypropylene
Needle fixing	Luer
Recommended needle	26G 10 mm.
Max. number of sterilizations	200
External dimensions (i.e. maximum barrel length x external diameter)	70 x 9 mm.

COMMENTS

Test Report: Prima 82111 (1982), Wolff Lab (1988)
Meets WHO/UNICEF Standard E8/SS.2
Suitable for BCG immunization of infants (0.05ml.).
Syringes delivered peel-packed; ETO sterilized.

2000 PRICES (FCA Roedby)

<i>Shipping volume (15 boxes)</i>	<i>0.032 m3</i>
<i>Shipping weight (15 boxes)</i>	<i>2.6 kg</i>
<i>Number of syringes per box</i>	<i>40</i>
<i>Minimum order:</i>	<i>15 boxes</i>
<i>(boxes of 10 are still available)</i>	
Price per box of	XEU 1.69 (US\$ 1.54)
10 syringes:	
Price per box of	XEU 5.80 (US\$ 5.27)
40 syringes:	

CODE
PIS
E8/03

Sterilizable plastic syringe, 5.0 ml

COMPANY NAME AND ADDRESS

CODAN Medical ApS
Faergevej 4
DK-4970 Roedby
Denmark
Telephone: 45 (54) 65 74 11
Fax: 45 (54) 60 51 01
E-mail: medical@codan.de

SPECIFICATIONS

Vaccine capacity	5.0 ml. x 0.5
Graduations	0.2 ml or 0.5 ml
Material of the syringe	Polypropylene
Needle fixing	Luer
Recommended needle	18G 50 mm.
Max. number of sterilizations	200
External dimensions (i.e. maximum barrel length x external diameter)	88 x 14 mm.

COMMENTS

Test Summary: CCIS 83.7 & 80.6
Meets WHO/UNICEF Standard E8/SS.3.
This is a mixing syringe.
Syringes delivered peel-packed; ETO sterilized.

2000 PRICES (FOB)

<i>Shipping volume (16 boxes)</i>	<i>0.106 m3</i>
<i>Shipping weight (16 boxes)</i>	<i>12.0 kg</i>
<i>Number of syringes per box</i>	<i>100</i>
<i>Minimum order :</i>	<i>48 boxes</i>
Price per 100	XEU 14.19 (US\$ 12.90)
syringes:	

CODE**PIS****E8/04**

Sterilizable plastic syringe, 0.05 ml
ref.: 0098NC

COMPANY NAME AND ADDRESS

Sedat S.A.
135 route Neuve
69540 Irigny
France
Telephone: 33 (4) 72 39 74 14
Fax: 33 (4) 78 51 89 67
E-mail: gerald.francou@sedat.com

SPECIFICATIONS

Vaccine capacity	0.05 ml.
Graduations	0.05 only
Material of the syringe	Polypropylene
Needle fixing	Luer
Recommended needle	25 G 10 mm.
Max. number of sterilizations	200
External dimensions (i.e. maximum barrel length x external diameter)	70 x 8 mm.

COMMENTS

Test Report: SPRIMA 750300 (1986)
Meets WHO/UNICEF Standard E8/SS.2.
Suitable for BCG immunization.
ETO sterile packed.

2000 PRICES (FOB)

<i>Shipping volume (480 boxes)</i>	0.173 m ³
<i>Shipping weight (480 boxes)</i>	17.5 kg
<i>Number of syringes per box</i>	10
<i>Minimum order:</i>	480 boxes

Price per box of XEU 1.69 (US\$ 1.54)
10 syringes:

CODE**PIS****E8/05**

Sterilizable plastic syringe, 0.5 ml

COMPANY NAME AND ADDRESS

CODAN Medical ApS
Faergevej 4
DK-4970 Roedby
Denmark
Telephone: 45 (54) 65 74 11
Fax: 45 (54) 60 51 01
E-mail: medical@codan.de

SPECIFICATIONS

Vaccine capacity	0.5 ml.
Graduations	0/0.5
Material of the syringe	Polypropylene
Needle fixing	Luer
Recommended needle	22G 32 mm.
Max. number of sterilizations	200
External dimensions (i.e. maximum barrel length x external diameter)	78 x 6 mm.

COMMENTS

Test Report: SPRIMA 750900 (1986)
Meets WHO/UNICEF Standard E8/SS.1.
Suitable for measles and DPT immunization of infants
and tetanus immunization of mothers.
Syringes delivered peel-packed; ETO sterilized.

2000 PRICES (FOB)

<i>Shipping volume (80 boxes)</i>	0.106 m ³
<i>Shipping weight (80 boxes)</i>	13 kg
<i>Number of syringes per box</i>	40
<i>Minimum order:</i>	80 boxes
<i>(boxes of 10 are still available)</i>	

Price per box of XEU 1.19 (US\$ 1.08)
10 syringes:
Price per box of XEU 4.50 (US\$ 4.09)
40 syringes:

CODE
PIS
E8/06

Sterilizable plastic syringe, 0.5 ml
ref.: 0123NA

COMPANY NAME AND ADDRESS

Sedat S.A.
135 route Neuve
69540 Irigny
France
Telephone: 33 (4) 72 39 74 14
Fax: 33 (4) 78 51 89 67
E-mail: gerald.francou@sedat.com

SPECIFICATIONS

Vaccine capacity	0.5 ml.
Graduations	0/0.5
Material of the syringe	Polypropylene
Needle fixing	Luer
Recommended needle	22G 32 mm.
Max. number of sterilizations	200
External dimensions (i.e. maximum barrel length x external diameter)	60 x 7 mm.

COMMENTS

Test Report: BSI 143193 & Prima 052200 (1990)
Meets WHO/UNICEF Standard E8/SS.1.
Suitable for measles and DPT immunization of infants
and tetanus immunization of mothers.
ETO sterile packed.

2000 PRICES (FOB)

<i>Shipping volume (480 boxes)</i>	0.173 m ³
<i>Shipping weight (480 boxes)</i>	17.5 kg
<i>Number of syringes per box</i>	10
<i>Minimum order:</i>	480 boxes

Price per box of XEU 1.42 (US\$ 1.29)
10 syringes

CODE
PIS
E8/07

Sterilizable syringe Kit A

COMPANY NAME AND ADDRESS

UNICEF (Denmark)
UNICEF Plads
Freeport, DK 2100 Copenhagen 0
Denmark
Telephone: 45 (35) 27 35 27
Fax: 45 (35) 26 94 21
E-mail: supply@unicef.dk

CONTENTS OF THE KIT

Item	Quantity	Stock no.
Syringes, 0.05 ml	1 box (of 10)	07 822 15
Syringes, 0.5 ml	4 boxes (of 10)	07 822 20
Syringes, 5.0 ml	4 syringes	07 819 05
Needles, 10 mm, 26 gg.	2 boxes (of 12)	07 515 02
Needles, 26 mm, 23 gg.	5 boxes (of 12)	07 507 00
Needles, 32 mm, 22 gg.	2 boxes (of 12)	07 505 00
Needles, 76 mm, 18 gg.	1 box (of 12)	07 488 50
Ampoule file, 50 mm	1	05 050 00
Nail brush	1	05 140 00

COMMENTS

Test Report: —
(No WHO/UNICEF Standard exists)

2000 PRICES (FCA)

<i>Shipping weight / volume</i>	0.7 kg / 0.004 m ³
<i>Shipping dimensions</i>	200x200x100 mm.
<i>External materials (package)</i>	cardboard box*
<i>Minimum order:</i>	1 kit
<i>Unicef Stock Number</i>	99 070 00

Quantity/Price: 1 kit/US\$ 19.42

* Overpacked for distribution in triple wall carton.

CODE**PIS****E8/08****Sterilizable syringe Kit B****COMPANY NAME AND ADDRESS**

UNICEF (Denmark)

UNICEF Plads

Freeport, DK 2100 Copenhagen 0

Denmark

Telephone: 45 (35) 27 35 27*Fax:* 45 (35) 26 94 21*E-mail:* supply@unicef.dk**CONTENTS OF THE KIT**

Item	Quantity	Stock no.
Syringes, 0.05 ml.	2 boxes (of 10)	07 822 15
Syringes, 0.5 ml	7 boxes (of 10)	07 822 20
Syringes, 5.0 ml	8 syringes	07 819 05
Needles, 10 mm, 26 gg.	4 boxes (of 12)	07 515 02
Needles, 26 mm, 23 gg.	8 boxes (of 12)	07 507 00
Needles, 32 mm, 22 gg.	4 boxes (of 12)	07 505 00
Needles, 76 mm, 18 gg.	1 box (of 12)	07 488 50
Ampoule files, 50 mm	2	05 050 00
Nail brush	2	05 140 00

COMMENTS*Test Report:* —*(No WHO/UNICEF Standard exists)***2000 PRICES (FCA)**

<i>Shipping weight / volume</i>	<i>1.3 kg / 0.006 m3</i>
<i>Shipping dimensions</i>	<i>300x200x100 mm</i>
<i>External materials (package)</i>	<i>cardboard box*</i>
<i>Minimum order</i>	<i>1 kit</i>
<i>Unicef Stock Number</i>	<i>99 071 00</i>

Quantity/Price: 1 kit/US\$ 34.42

* Overpacked for distribution in triple wall carton.

CODE**PIS****E8/09****Autodisable syringe, 0.5 ml
Soloshot (TM)****COMPANY NAME AND ADDRESS**

BD Medical Systems

1 Becton Drive

Franklin Lakes, NJ 07417

USA

Telephone: 1(201) 847 60 15*Fax:* 1 (201) 847 48 45*E-mail:* Immunization@bd.com**SPECIFICATIONS**

Vaccine capacity	0.5 ml.
Graduations	0.5 ml
Material of the syringe	Polypropylene
Fixed needle	23G x 25 mm.
	Fixed
Prevented from re-use by	locked/trapped piston

COMMENTS*Test Report: Sprima 951700 (1989)**Meets WHO/UNICEF Standard E8/DS.1*

Needle cap and cap over thumb plate make the syringe a sterile unit.

Yellow ring seal : provides evidence of prior opening and use.

2000 PRICES (FOB)

<i>Shipping volume (1 case)</i>	<i>0.018m3</i>
<i>Shipping dimensions</i>	<i>375x170x285mm</i>
<i>Shipping weight</i>	<i>3.9. kg</i>
<i>Number of syringes per shelfpack</i>	<i>100</i>
<i>Number of syringes per carton</i>	<i>500</i>
<i>Minimum order:</i>	<i>500</i>

Price per shelfpack of 100 syringes:

<u>Number of Syringes</u>	<u>Price</u>
Over 50 Million	\$7.40
Under 50 Million	\$7.70

CODE
PIS
E8/10

**Autodisable syringe, 0.5 ml:
DestroJect**

COMPANY NAME AND ADDRESS

DestroJect GmbH Medical Devices
Havelstrasse 1-3
D-24539 Neumuenster
Germany
Telephone: 49 (43) 21 88 00 88
Fax: 49 (43) 21 81 85 5
E-mail: info@destroject.de

SPECIFICATIONS

Vaccine capacity 0.5 ml.
Graduations 0.5 ml
Material of the syringe Polypropylene
Fixed needle 23g x 25mm
Prevented from re-use by locked/trapped piston

COMMENTS

Test Report: Sprima 051400 (1990)
Meets WHO/UNICEF Standard E8/DS.1
Needle cap and cap over thumb plate make syringe into a sterile unit. Supplied and packaged in SyringeSafe triple purpose combustion container.

2000 PRICES (EX WORKS)

Shipping volume (20 boxes) 0.1 m³
Shipping weight (20 boxes) 12.8 kg
Number of syringes per box 100
Minimum order: 30 box

Price per box of DEM 15.00 (US\$ 7.32)
100 syringes

CODE
PIS
E8/11

**Pump dispenser for micronutrients.
Model Englass Swift "OR"**

COMPANY NAME AND ADDRESS

Englass Dispensing & Packaging Systems
Scudamore Road
Leicester LE3 1UG
United Kingdom
Telephone: 44 (116) 233 11 00
Fax: 44 (116) 231 20 77

SPECIFICATIONS

Dose: 0.5 ml
Dose tolerance: 0.43 to 0.53 ml with water
Closure insert: BS 28/R3, US 28/400
Nozzle cap: red low density polyethylene
Ball valves: Stainless steel
Springs: Stainless steel
Suction pipe/ventilator: Natural low density polyethylene
Other injection mouldings: white polypropylene

COMMENTS

Test Report: CRL A.9014, A.9061, A.9070 (1990-92)
(No WHO/UNICEF Standard exists.)
Suitable for use with Vitamin A solution. Tested for accuracy, wastage, sterilising, endurance, ease of use, priming and re-use after interval. Vitamin A solution to be ordered separately, either in bulk or in individual bottles (60 ml recommended.)

2000 PRICES (FOB)

Shipping volume (1 package) 0.072 m³
(50x40x36 cm)
Shipping weight (1 package) 13.5 kg
Number of pumps per package: 400
Minimum order: 5000

Quantity/Price: 1/GB£ 1.29 (US\$ 2.02)

CODE**PIS****E8/12****Autodisable syringe, 0.5 ml****COMPANY NAME AND ADDRESS**

UNIVEC

22 Dubon Court

Farmingdale, NY 11735

United States of America

Telephone: 1 (516) 777-20 00

Fax: 1 (516) 777-27 86

E-Mail: Univec@Univec.com

SPECIFICATIONS

Vaccine capacity	0.5 ml.
Graduations	0.5 ml
Material of the syringe	Polypropylene
Fixed needle	23g x 25 mm.
Prevented from re-use by	locked/trapped piston

This syringe is also available with other non-specification needle sizes

COMMENTS

Test Report: Force 124982 (1999)

Test Report: Semko 451000 (1994)

Meets WHO/UNICEF Standard E8/DS.1

Syringe can be ordered either:

- Packaged individually in a blisterpak –each blister is a sterile unit; *or*
- Without individual packing -- the integral plunger cap and needle cap make each syringe into a sterile unit.

2000 PRICES (FOB)

Shipping volume	0.0053 m ³
Shipping weight	0.525 kg
Number of syringes per box:	100
Minimum order:	100 boxes

Price per container of 100 syringes:

Packaged individually in blisterpak	US\$ 8.95
Packaged 100 to a bag	US\$ 8.95

CODE**PIS****E8/17****Autodisable syringe, 0.5 ml
Soloshot (TM) FX****COMPANY NAME AND ADDRESS**

BD Medical Systems

1 Becton Drive

Franklin Lakes, NJ 07417

USA

Telephone: 1(201) 847 60 15

Fax: 1 (201) 847 48 45

E-mail: Immunization@bd.com

SPECIFICATIONS

Vaccine capacity	0.5 ml.
Graduations	0.5 ml
Material of the syringe	Polypropylene
Fixed needle	23G x 25 mm.
Prevented from re-use by	Non-standard locked/trapped piston

COMMENTS

Test Report: Force127734/ml1460-280,

124716/ml1460-260 (1999)

Meets WHO/UNICEF Standard E8/DS.1

Syringe and needle packaged together in sterile single-unit blister pack. No rubber stopper.

Detachable needle can facilitate separate disposal of needles and syringes.

2000 PRICES (FOB)

Shipping volume (1 case)	0.103m ³
Shipping dimensions	595x403x429cm
Shipping weight	14.2kg
Number of syringes per shelf-pack	100
Number of syringes per carton	3000
Minimum order:	3000

Price per shelfpack of 100 syringes:

Number of Syringes	Price
Under 30 Million	\$7.40
30 to 50 Million	\$7.10
50 to 95 Million	\$6.80
Over 95 Million	\$6.60

CODE**PIS****E8/18****Autodisable syringe, 0.05 ml****COMPANY NAME AND ADDRESS**

UNIVEC

22 Dubon Court

Farmingdale, NY 11735

United States of America

Telephone: 1 (516) 777-20 00*Fax:* 1 (516) 777-27 86*E-Mail:* Univec@Univec.com**SPECIFICATIONS**

Vaccine capacity	0.05 ml.
Graduations	0.05 ml
Material of the syringe	Polypropylene
Fixed needle	27g x 10 mm.
Prevented from re-use by	locked/trapped piston

This syringe is also available with other non-specification needle sizes

COMMENTS*Test Report: Force 124982 (1999)**Test Report: Semko 451000 (1994)**Meets WHO/UNICEF Standard E8/DS.1*

- Packaged individually in a blisterpak –each blister is a sterile unit.

2000 PRICES (FOB)

<i>Shipping volume</i>	0.0053 m ³
<i>Shipping weight</i>	0.525 kg
<i>Number of syringes per box:</i>	100
<i>Minimum order:</i>	100 boxes

Price per container of 100 syringes:

Packaged individually in blisterpak US\$ 8.95

CODE**PIS****E8/19****Autodisable syringe, 0.5 ml****Model K1****COMPANY NAME AND ADDRESS**

Star Syringe Limited

Gossard House, 7-8 Saville Row

London W1X 1AF

Great Britain

Telephone: 44 (207) 292 08 00*Fax:* 44 (207) 292 08 01*E-Mail:* mkoska@starsyringe.co.uk**SPECIFICATIONS**

Vaccine capacity	0.5 ml.
Graduations	0.5 ml
Material of the syringe	Polypropylene
Fixed needle	23g x 25 mm.
Prevented from re-use by	locking piston with break point

This syringe is also available with other non-specification needle sizes

COMMENTS*Test Report: Force 132872 (2000)**Meets WHO/UNICEF Standard E8/DS.1*

- Supplied with needle cap and blister packed for sterility.

2000 PRICES (FOB)

<i>Shipping volume</i>	0.006 m ³
<i>Shipping weight</i>	1.05 kg
<i>Number of syringes per box:</i>	100
<i>Minimum order:</i>	600 syringes

Price per container of 100 syringes:

US\$ 6.25

CODE**PIS****E8/20****Autodisable syringe, 0.05 ml
K1 BCG****COMPANY NAME AND ADDRESS**

Star Syringe Limited

Gossard House, 7-8 Saville Row

London W1X 1AF

Great Britain

Telephone: 44 (207) 292 08 00*Fax:* 44 (207) 292 08 01*E-Mail:* mkoska@starsyringe.co.uk**SPECIFICATIONS**

Vaccine capacity	0.05 ml.
Graduations	0.05 ml
Material of the syringe	Polypropylene
Fixed needle	27g x 10 mm.
Prevented from re-use by	locking piston with break point

This syringe is also available with other non-specification needle sizes

COMMENTS*Test Report: Force 200329 (2000)**Meets WHO/UNICEF Standard E8/DS.2*

- Supplied with needle cap and blister packed for sterility.

2000 PRICES (FOB)

<i>Shipping volume</i>	0.006 m ³
<i>Shipping weight</i>	1.05 kg
<i>Number of syringes per box:</i>	100
<i>Minimum order:</i>	600 syringes
Price per container of 100 syringes:	US\$ 6.25

Section E9

Steam sterilizers

1. Introduction

The WHO policy on the selection of syringes, needles, sterilizers and other injection equipment exists as a separate document: *Injection safety in immunization programmes: WHO recommended policy* (WHO/EPI/LHIS/96.05) available from the WHO/V&B Document Centre.

The steam sterilizers included in this section have been designed for use with the sterilizable, single dose, plastic syringes listed in Section E8. As part of a modular system, the sterilizers accept one, two or three standard racks. Each rack can hold 42 syringes (either 0.5 ml or 0.05 ml), together with 50 needles and a 5.0 ml mixing syringe.

Pressure sterilizers may also be used in other primary health care programmes. For example, a pressure sterilizer can be used for:

- 2.0 ml/5.0 ml syringe rack designed for use in general primary health care.
- General-purpose instrument container or an extra long instrument container for use with longer instruments such as those used in gynaecology.
- Rack and cassette boxes for use with dental instruments.

Sterilizers are being supplied with valves that allow the sterilizer to achieve sterilization conditions at altitudes up to 2100 metres. If sterilization is required at altitudes above this level, the time of sterilization has to be increased. The sterilizers should last 10 years before being replaced, but require routine maintenance throughout their life. The manufacturers recommend that the rubber seal and safety pintel in each sterilizer be replaced every year. (*See instruction booklet with each unit for more details.*)

Time steam temperature control indicators must be included in each sterilization cycle to check that the sterilization was correctly performed. The indicators must be inspected at the time of use and attached to the immunization report. Such indicators are listed in section E10 of this catalogue. They are also supplied systematically by the different procurement agencies supplying sterilization kits and listed in this document.

**Figure 1: Guide to external dimensions of sterilizers
(AxBxCxD)**

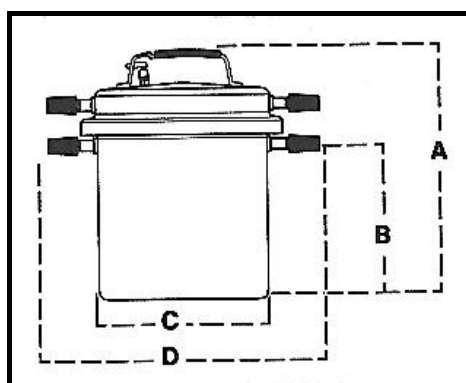

CODE

PIS E9/01

Single rack steam sterilizer: Model 750900

COMPANY NAME AND ADDRESS

Prestige Medical Ltd.
P. O. Box 154
Off Clarendon Road
Blackburn, Lancashire BB1 9UG, England
Telephone: 44 (1254) 68 26 22
Fax: 44 (1254) 68 26 06
E-mail: customerservices@prestigemedical.co.uk

SPECIFICATIONS

Number of syringes per rack (0.1/1.0 ml)	42
Number of syringes per rack (5.0 ml)	2
Number of needles per rack	50
Number of racks included	1
Weight loaded (without water)	2.2 kg
Material of sterilizer body	Aluminium
External dimensions (AxBxCxD)	186x87x216x337 mm

PERFORMANCE

Operating temperature (sea level)	125°C
Power consumption/sterilization:	
electricity:	0.45 kwh.
kerosene:	130 ml.
LP gas:	0.53 kg.

SPARES NEEDED PER 10 UNITS	Part No.	Qty	Price/unit			
Sealing gasket	752200	1	GB£	2.95	(US\$	4.61)
Safety plug (x2)	751800	6	GB£	2.10	(US\$	3.28)
Replacement handle	751700	2	GB£	2.25	(US\$	3.52)
Depressurisation valve	751900	6	GB£	3.15	(US\$	4.92)

COMMENTS AND ACCESSORIES

Test Reports: CCIS/83.7, CRL A.9918 (1983), Dantest 39684 (1990);

Meets WHO/UNICEF Standard: E9/PS.1

Recommendation: To confirm the completion of sterilization cycles, WHO recommends the systematic use of TST strips or spots (E10/06 and 07).

Accessories: 2 safety plugs, carry-bag, syringe bowl, 3 spare sealing gaskets and instruction booklet in English/French/Spanish. Packaged 6 per water resistant export carton. Syringes and needles not included. Steam sterilizer, model 750200, with 2 ml/5ml syringe rack also available.

2000 PRICES (FOB)

Shipping weight / volume (carton of 6) 22 kg / 0.125 m³
Minimum order: 6 (and in multiples of 6)

Quantity/Price: 1/GB£ 67.00 (US\$ 104.69)

CODE

PIS E9/02

Double rack steam sterilizer: Model 750600

COMPANY NAME AND ADDRESS

Prestige Medical Ltd.
P. O. Box 154
Off Clarendon Road
Blackburn, Lancashire BB1 9UG, England
Telephone: 44 (1254) 68 26 22
Fax: 44 (1254) 68 26 06
E-mail: customerservices@prestigemedical.co.uk

SPECIFICATIONS

Number of syringes per rack (0.1/1.0 ml)	42
Number of syringes per rack (5.0 ml)	2
Number of needles per rack	50
Number of racks included	2
Weight loaded (without water)	3.5 kg.
Material of sterilizer body	Aluminium
External dimensions (AxBxCxD)	300x205x216x337 mm.

PERFORMANCE

Operating temperature (sea level)	125°C
Power consumption/sterilization:	
electricity:	0.45 kwh.
kerosene:	130 ml.
LP gas:	0.53 kg.

SPARES NEEDED PER 10 UNITS

	Part No.	Qty	Price/unit			
Sealing gasket	752200	1	GB£	2.95	(US\$	4.61)
Safety plug (x2)	751800	6	GB£	2.10	(US\$	3.28)
Replacement handle	751700	3	GB£	2.25	(US\$	3.52)
Depressurisation valve	751900	6	GB£	3.15	(US\$	4.92)

COMMENTS AND ACCESSORIES

Test reports: CCIS/83.7, CATRA.9108 (1983), Dantest 39084 (1990);

Meets WHO/UNICEF Standard: E9/PS.2

Recommendation: To confirm the completion of sterilization cycles, WHO recommends the systematic use of TST strips or spots (E10/06 and 07).

Accessories: 2 safety plugs, carry-bag, syringe bowl, 3 spare sealing gaskets and instruction booklet in English/French/Spanish. Packaged 4 per water resistant export carton. Syringes and needles not included. Steam sterilizer, model 750300, with 2ml/5ml syringe rack also available.

2000 PRICES (FOB)

Shipping weight / volume (carton of 4) 18.2 kg / 0.119 m³
Minimum order: 4 (and in multiples of 4)

Quantity/Price: 1/GB£ 74.60 (US\$ 116.56)

CODE

PIS E9/03

**Single rack steam sterilizer:
Model CertoClav KC 5L, 85.016.05**

COMPANY NAME AND ADDRESS

Certoclav Sterilizer GmbH

Obere Dorfstrasse 1

A-4050 Traun

Austria

Telephone: 43 (7229) 68 96 89

Fax: 43 (7229) 741 41

E-mail: certoclav@gruber-kaja.at

SPECIFICATIONS

Number of syringes per rack (0.1/1.0 ml)	40
Number of syringes per rack (5.0 ml)	2
Number of needles per rack	50
Number of racks included	1
Weight loaded (without water)	2.8 kg.
Material of sterilizer body	Stainless steel
External dimensions (AxBxCxD)	170x130x225x370 mm.

PERFORMANCE

Operating temperature (sea level)	125°C
Power consumption/sterilization:	
electricity:	0.80 kWh
kerosene:	100 ml.
LP gas:	0.59 kg

SPARES NEEDED PER 10 UNITS

	Part No.*	Qty	Price/unit
Gasket	12.522.18	3	US\$ 4.80
Steam release valve	12.526.03	1	US\$ 4.60
Safety valve	12.527.18	2	US\$ 2.85
Pressure valve	12.503.13	1	US\$ 13.98
Lower handle	12.502.37	1	US\$ 8.07
Cover handle, with locking mechanism	12.599.08	1	US\$ 6.00
Cover handle, without locking mechanism	12.599.15	1	US\$ 4.80

COMMENTS AND ACCESSORIES

Reports: CATR. A.9918 (1983), Dantest 39084 (1990); Meets WHO/UNICEF Standard: E9/PS.1

Recommendation: To confirm the completion of sterilization cycles, WHO recommends the systematic use of TST strips or spots (E10/06 and 07).

Accessories: carry-bag, syringe bowl, 3 spare gaskets, 2 spare safety valves. Packaged 6 per master carton.

2000 PRICES (FOB)

Shipping weight / volume (carton of 6) 28.5 kg / 0.130 m³

Minimum order: 1

Quantity/Price:	1-99	1/US\$	128.00
	100-499	1/US\$	80.50
	500 +	1/US\$	67.30

* Part numbers apply to parts for short-handled model only. When ordering for long-handle model specify that parts are for long-handled model and list parts by name only.

CODE

PIS E9/04

Triple rack steam sterilizer: Model 750500

COMPANY NAME AND ADDRESS

Prestige Medical Ltd.
P. O. Box 154
Off Clarendon Road
Blackburn, Lancashire BB1 9UG, England
Telephone: 44 (1254) 68 26 22
Fax: 44 (1254) 68 26 06
E-mail: customerservices@prestigemical.co.uk

SPECIFICATIONS

Number of syringes per rack (0.1/1.0 ml)	42
Number of syringes per rack (5.0 ml)	2
Number of needles per rack	50
Number of racks included	3
Weight loaded (without water)	3.9 kg
Material of sterilizer body	Aluminium
External dimensions (AxBxCxD)	390x290x216x337 mm

PERFORMANCE

Operating temperature (sea level)	125°C
Power consumption/sterilization:	
electricity:	0.5 kwh
kerosene:	140 ml
LP gas:	0.55 kg

SPARES NEEDED PER 10 UNITS

	Part No.	Qty	Price/unit		
Syringe racks/lid for 0.1/1.0 syringes	751400	3	GB£	11.20	(US\$ 17.50)
Depressurisation valve	751900	2	GB£	3.15	(US\$ 4.92)
Sealing gasket	752200	6	GB£	2.95	(US\$ 4.61)
Replacement handle	751700	4	GB£	2.25	(US\$ 3.52)

COMMENTS AND ACCESSORIES

Reports: PHLS-Nov.87; Meets WHO/UNICEF Standard: E9/PS.2

Recommendation: To confirm the completion of sterilization cycles, WHO recommends the systematic use of TST strips or spots (E10/06 and 07).

Accessories: 2 safety plugs, 3 spare sealing gaskets, carrying pack, syringe bowl and instruction booklet in English/French/Spanish.

Packaged 4 per water resistant export carton.

Syringes and needles not included.

2000 PRICES (FOB)

Shipping weight / volume (carton of 4) 19.6 kg / 0.150 m³
Minimum order: 4 (and multiples of 4)

Quantity/Price: 1/GB£ 90.00 (US\$ 140.63)

CODE

PIS E9/05

**Double rack steam sterilizer:
Model CertoClav KC 8L, 85.016.08**

COMPANY NAME AND ADDRESS

Certoclav Sterilizer GmbH

Obere Dorfstrasse 1

A-4050 Traun

Austria

Telephone: 43 (7229) 68 96 89

Fax: 43 (7229) 741 41

E-mail: certoclav@gruber-kaja.at

SPECIFICATIONS

Number of syringes per rack (0.1/1.0 ml)	40
Number of syringes per rack (5.0 ml)	2
Number of needles per rack	50
Number of racks included	2
Weight loaded (without water)	3.5 kg.
Material of sterilizer body	Stainless steel
External dimensions (AxBxCxD)	270x230x225x370 mm.

PERFORMANCE

Operating temperature (sea level)	125°C
Power consumption/sterilization:	
electricity:	0.80 kwh.
kerosene:	1.00 ml.
LP gas:	0.59 kg.

SPARES NEEDED PER 10 UNITS

	Part No.*	Qty	Price/unit
Gasket	12.522.18	3	US\$ 4.80
Steam release valve	12.526.03	1	US\$ 4.60
Safety valve	12.527.18	1	US\$ 2.85
Pressure valve	12.503.13	1	US\$ 13.98
Lower handle	12.502.37	1	US\$ 8.07
Cover handle, with locking mechanism	12.599.08	1	US\$ 6.00
Cover handle, without locking mechanism	12.599.15	1	US\$ 4.80

COMMENTS AND ACCESSORIES

Reports: CATR. A.9918 (1983), CRL A.9108 (1983), Dantest 39084 (1990); Meets WHO/UNICEF Standard: E9/PS.2

Recommendation: To confirm the completion of sterilization cycles, WHO recommends the systematic use of TST strips or spots (E10/06 and 07).

Accessories: carry-bag, syringe bowl, 3 spare gaskets, 2 spare safety valves. Packaged 4 per master carton.

2000 PRICES (FOB)

Shipping weight / volume (packaged 4 per mastercarton) 23.70 kg / 0.130 m³

Minimum order: 1

Quantity/Price:	1-99	1/US\$	162.00
	100-499	1/US\$	95.40
	500 +	1/US\$	79.50

* Part numbers apply to parts for short-handled model only. When ordering for long-handle model specify that parts are for long-handled model and list parts by name only.

CODE

PIS E9/07

Double rack electric steam sterilizer: Model 210005 (220/240V)

COMPANY NAME AND ADDRESS

Prestige Medical Ltd.
P. O. Box 154
Off Clarendon Road
Blackburn, Lancashire BB1 9UG, England
Telephone: 44 (1254) 68 26 22
Fax: 44 (1254) 68 26 06
E-mail: customerservices@prestigemedical.co.uk

SPECIFICATIONS

Number of syringes per rack (0.1/1.0 ml)	42
Number of syringes per rack (5.0 ml)	2
Number of needles per rack	50
Number of racks included	2
Weight loaded (without water)	5.5 kg
Material of sterilizer body	Aluminium, powder coat painted exterior
External dimensions (AxBxCxD)	300x205x216x337 mm

PERFORMANCE

Operating temperature (sea level)	121°C
Power consumption/sterilization:	
electricity:	1500 kwh
kerosene:	— ml
LP gas:	— kg

SPARES NEEDED PER 10 UNITS

	Part No.	Qty	Price/unit		
Sealing gasket (silicone, green)	219500	12	GB£	9.50	(US\$ 14.84)
Replacement handle, complete (for body)	219207	1	GB£	3.70	(US\$ 5.78)
Replacement handle, complete (for top lid)	219204	1	GB£	13.20	(US\$ 20.63)
Depressurisation valve, complete	219201	1	GB£	9.50	(US\$ 14.84)
Plug/cable set with in-line power protector	219298	1	GB£	65.00	(US\$ 101.56)

COMMENTS AND ACCESSORIES

Reports: CCIS/83.7, CRL A.92410 (1989), CRL A.9071 (1992). Meets WHO/UNICEF Standard: E9/PS.2

Recommendation: To confirm the completion of sterilization cycles, WHO recommends the systematic use of TST strips or spots (E10/06 and 07).

Accessories: Hard water filter (E10/03), 1 spare sealing gasket, special 2-meter length cord set with inline over/under power protector and re-set button (protects unit outside normal operating voltage of 195V to 255V), 2 spare voltage protector unit fuses (8 amp) and product fuses (10 amp), operating/instruction booklets. Syringes and needles not included. Packaged 3 per water resistant export carton.

2000 PRICES (FOB)

Shipping weight / volume (carton of 3) 24.0 kg / 0.176 m³
Minimum order: 3

Quantity/Price*:	1 - 11:	GB£	410.00	(US\$	640.63)
	12 +	GB£	360.00	(US\$	562.50)

* Price includes export outer/packing.

CODE**PIS E9/08**

Sterilizer Kit A
(Syringes not included)

COMPANY NAME AND ADDRESS

UNICEF (Denmark)
UNICEF Plads
Freeport, DK 2100 Copenhagen 0
Denmark
Telephone: 45 (35) 27 35 27
Fax: 45 (35) 26 94 21
E-mail: supply@unicef.dk

CONTENTS OF THE KIT

Item	Quantity	Stock number
Sterilizer, complete with 1 syringe rack	1	01 571 10
Forceps, 155 mm	1	07 210 00
Timer	1	09 834 00
Soap box	1	05 510 04
Indicator TST control spot	1 pack	05 581 00

COMMENTS

Test Report: —

(No WHO/UNICEF Standard exists)

Recommendation: To confirm the completion of sterilization cycles, WHO recommends the systematic use of TST strips or spots (E10/06 and 07).

The kit also contains the standard items normally included with this sterilizer (2 safety valves, 1 carry bag, 1 syringe bowl, 3 spare sealing gaskets, instruction booklets). Syringes are not provided.

2000 PRICES (FCA)

<i>Shipping weight / volume (1 kit)</i>	6.0 kg / 0.047 m ³
<i>Shipping dimensions</i>	440x380x280 mm
<i>External materials (package)</i>	Cardboard*
<i>Number per package</i>	1
<i>Minimum order</i>	1 kit
<i>UNICEF Stock number:</i>	99 080 00

Quantity/Price: 1/US\$ 86.35

* Overpacked in triple wall carton.

CODE

PIS E9/09

Sterilizer Kit B
(Syringes not included)

COMPANY NAME AND ADDRESS

UNICEF (Denmark)
UNICEF Plads
Freeport, DK 2100 Copenhagen 0
Denmark
Telephone: 45 (35) 27 35 27
Fax: 45 (35) 26 94 21
E-mail: supply@unicef.dk

CONTENTS OF THE KIT

Item number	Quantity	Stock
Sterilizer, complete with 2 syringe racks	1	01 571 00
Forceps, 155 mm	2	07 210 00
Timer	1	09 834 00
Soap box	2	05 510 04
Indicator TST control spot	1 pack	05 581 00

COMMENTS

Test Report: —

(No WHO/UNICEF Standard exists)

Recommendation: To confirm the completion of sterilization cycles, WHO recommends the systematic use of TST strips or spots (E10/06 and 07).

The kit also contains the standard items normally included with this sterilizer (2 safety valves, 1 carry bag, 1 syringe bowl, 3 spare sealing gaskets, instruction booklets). Syringes are not provided.

2000 PRICES (FCA)

Shipping weight / volume (1 kit) 8.0 kg / 0.050 cubic metres
Shipping dimensions 490x310x330 mm
External materials (package) Cardboard*
Number per package 1
Minimum order 1 kit
UNICEF Stock number 99 081 00

Quantity/Price: 1/US\$ 107.24

* Overpacked in triple wall carton.

CODE

PIS E9/13

Multi purpose double rack sterilizer: Model 750300

COMPANY NAME AND ADDRESS

Prestige Medical Ltd.
P. O. Box 154
Off Clarendon Road
Blackburn, Lancashire BB1 9UG, England
Telephone: 44 (1254) 68 26 22
Fax: 44 (1254) 68 26 06
E-mail: customerservices@prestigemedical.co.uk

SPECIFICATIONS

Number of syringes per rack (2.0 ml)	52
Number of syringes per rack (5.0 ml)	24
Number of needles per rack	42
Number of racks included	2
Weight loaded (without water)	3.5 kg
Material of sterilizer body	Aluminium
External dimensions (AxBxCxD)	300x205x216x337 mm

PERFORMANCE

Operating temperature (sea level)	125°C
Power consumption/sterilization:	
electricity:	0.45 kwh.
kerosene:	130 ml.
LP gas:	0.53 kg.

SPARES NEEDED PER 10 UNITS	Part No.	Qty	Price/unit		
Sealing gasket	752200	1	GB£	2.95	(US\$ 4.61)
Safety plug (X2)	751800	6	GB£	2.10	(US\$ 3.28)
Replacement handle	751700	3	GB£	2.25	(US\$ 3.52)
Depressurisation valve	751900	6	GB£	3.15	(US\$ 4.92)

COMMENTS AND ACCESSORIES

Test reports: CCIS/83.7, CATRA.9108 (1983), Dantest 39084 (1990);

Meets WHO/UNICEF Standard: E9/PS.2

Recommendation: To confirm the completion of sterilization cycles, WHO recommends the systematic use of TST strips or spots (E10/06 and 07).

Accessories: 2 safety plugs, carry-bag, syringe bowl, 3 spare sealing gaskets and instruction booklet in English/French/Spanish. Packaged 4 per water resistant export carton. Syringes and needles not included.

2000 PRICES (FOB)

Shipping weight / volume (carton of 4) 18.2 kg / 0.119 m³
Minimum order: 4 (and in multiples of 4)

Quantity/Price: 1/GB£ 70.00 (US\$ 109.38)

CODE

PIS E9/14

Thermal solar steam sterilizer**COMPANY NAME AND ADDRESS**

TriSolar Foundation Trust
 c/o Orbital Engine Company
 1 Whipple Street
 Balcatta 6021
 Western Australia
Telephone: 61 (8) 94 41 23 21
Fax: 61 (8) 94 41 23 45
E-mail: pewing@orbeng.com.au

SPECIFICATIONS**Standard double rack sterilizer (E9/PS.2)**

1 E9/05 (or any standard sterilizer which meets WHO/UNICEF specifications E9/PS.2)

Sterilizer drums

2 x E10/10, 11 or 12

Solar collector includes

heat sink; 2 heat pipes collectors

Materials:**Outer casing**

Fibre reinforced plastic

Insulation

Glass wool

Support

Steel

PERFORMANCE**Operating temperature (sea level)**

121°C

Number of cycles per day

8

Energy source:

solar energy (thermal)

Suitable for areas with:

5 kwh/m²/day insolation

SPARES NEEDED PER 10 UNITS

	Part No.	Qty	Price/unit
Rubber seal for lid	12522.18	3	US\$ 4.80
Safety valve on lid	12527.18	1	US\$ 2.85
Release pressure valve	12503.13	1	US\$ 13.98

COMMENTS AND ACCESSORIES

Reports: Mueri, July 1991. Also field tested over two years in Malawi, Tanzania and Zambia.

Recommendation: To confirm the completion of sterilization cycles, WHO recommends the systematic use of TST strips or spots (E10/06 and 07).

Erection and operation of this appliance is a simple task which may be performed by one person. A manual provides clear instructions.

Sterilizer equipped with standard safety valve, pressure release valve and indicator button.

Can also be used to sterilize other equipment.

2000 PRICES (EX WORKS)

Shipping weight / volume 37 kg / 0.2 m³

Minimum order: 1

Quantity/Price: 1/US\$ 1 500.00

CODE**PIS E9/15****Sterilization Module: 15 I****COMPANY NAME AND ADDRESS**

Médecins Sans Frontières Logistique

14 Av. de l'Argonne

33700 Mérignac

France

Telephone: 33 (5) 56 13 73 73*Fax:* 33 (5) 56 13 73 74*E-mail:* standard@bordeaux.msf.org**CONTENTS OF MODULE**

Item	Qty
FORCEPS KOCHER, DRESS. 14 cm, straight no teeth, autoclav.	1
AUTOCLAVE, ""Prestige""immun. racks 84 syr. + spares w/o burner"	1
RACK, syringes 26 x 2 + 12 x 5 ml"	2
BURNER, PRESSURE, kerosene 2.4 l 1 burner Hyppolito Fama 836	1
FILTER, HARD WATER"	1
TAPE, AUTOCLAVE, 50 m x 19 mm	2
TIMER, 60 mn	1
GUIDELINE DESINFECTION & STERILIZATION, french/english	1
GLOVES, CLEANING, rubber, reusable, large (pair)	1
GLOVES, CLEANING, rubber, reusable, medium (pair)	1
GLOVES, CLEANING, rubber, reusable, small (pair)	1

COMMENTS

The module contains all equipment, including burner and gloves, necessary to sterilize 84 syringes and needles for EPI. It can be used in combination with syringe kits E8/15 and 16.

Recommendation: To confirm the completion of sterilization cycles, WHO recommends the systematic use of TST strips or spots (E10/06 and 07).

2000 PRICES (FOB)

Shipping weight/volume 11 kg / 0.1 m³

Minimum order: 1

Item	Code	Price/unit
COMPLETE MODULE	KMEDMSTE15-	XEU 252.82 (US\$ 229.84)

CODE

PIS E9/18

**Single rack steam sterilizer:
Model UAP121**

COMPANY NAME AND ADDRESS

ALMAS
Jl. Industri II No. 6
Leuwigajah; Cimindi,
Bandung (West Java), Indonesia
Telephone: 62 (22) 603 13 71/04 04
Fax: 62 (22) 603 37 96

SPECIFICATIONS

Number of syringes per rack (0.1/1.0 ml)	38-42
Number of syringes per rack (5.0 ml)	2
Number of needles per rack	44-50
Number of racks included	1
Weight loaded (without water)	2.5 kg
Material of sterilizer body	Stainless steel 304
External dimensions (AxBxCxD)	207 x 80 x 217 x 338 mm

PERFORMANCE

Operating temperature (sea level)	126°C
Power consumption/sterilization:	
electricity:	0.504 kwh.
kerosene:	106 ml.
LP gas:	0.065 kg.

SPARES NEEDED PER 10 UNITS	Part No.	Qty	Price/unit
Gasket	62-202-3	3	US\$ 3.00
Safety valve	62-202-5	1	US\$ 1.50
Replacement handle	62-202-6	1	US\$ 1.50
Pressure valve	62-202-4	1	US\$ 5.00

COMMENTS AND ACCESSORIES

Test reports: BSI EP004595 (1996)

Meets WHO/UNICEF Standard: E9/PS.1

Recommendation: To confirm the completion of sterilization cycles, WHO recommends the systematic use of TST strips or spots (E10/06 and 07).

Almas produce double and triple rack sterilizers (currently untested).

2000 PRICES (FOB)

Shipping weight / volume (12 pcs) 15.2 kg / 0.076 m³
Minimum order: 500

Quantity/Price: 1/US\$ 41.00

CODE

PIS E9/19

Single rack steam sterilizer: Model XS22 and XS22A

COMPANY NAME AND ADDRESS

Zhejiang Supor Co. Ltd.
Da Mai Yu Development District
Yu Huan 317 604
Zhejiang Province
P.R. China
Telephone: 86 (576) 733 2913 / 3926
Fax: 86 (576) 733 3926 / 2916
E-mail: zjsupor@mail.tzptt.zj.cn

SPECIFICATIONS

Number of syringes per rack (0.1/1.0 ml)	42
Number of syringes per rack (5.0 ml)	2
Number of needles per rack	50
Number of racks included	1 (2 sizes available – see comments)
Weight loaded (without water)	[2.7] kg
Material of sterilizer body	Aluminum
External dimensions (AxBxCxD)	XS22 220 x 135 x 225 x 430 mm XS22A 220 x 135 x 225 x 370 mm

PERFORMANCE

Operating temperature (sea level)	125°C
Power consumption/sterilization:	
electricity:	0.45 kwh
kerosene:	105 ml
LP gas:	0.53 kg

SPARES NEEDED PER 10 UNITS	Part No.	Qty	Price/unit
Sealing gasket (silicon white)	--	3	US\$ 1.50
Safety plug	--	2	US\$ 1.50
Depressurisation valve	--	1	US\$ 1.50
Replacement handle	--	1	US\$ 1.50

COMMENTS AND ACCESSORIES

Test reports: BSI EP004595 (1996), China NHEAC WB-98-023(December 1998),

Meets WHO/UNICEF Standard: E9/PS.1

Two types of racks are available : 0.1/1.0 & 5ml and 2.0 & 5.0ml. State which rack is required.

A high altitude sterilizer has been developed but has not as yet been independently tested.

The difference between the two models is the handle lengths of 15 (XS22) and 7cm (XS22A) respectively.

Recommendation: To confirm the completion of sterilization cycles, WHO recommends the systematic use of TST strips or spots (E10/06 and 07).

Accessories (syringes and needles not included): carry bag, syringe/needle rack , 2 spare safety plugs, 3 spare lid seals, plastic bowl for washing syringes, instruction booklet available in English/French/Spanish.

2000 PRICES (FOB)

Shipping weight / volume (4 pcs)	XS22	14.5 kg / 0.135 m ³
	XS22A	14.5 kg / 0.119 m ³
Minimum order:		1

Quantity/Price 1/US\$ 38.00

CODE

PIS E9/20

Double rack steam sterilizer: Model XD22 and XD22A

COMPANY NAME AND ADDRESS

Zhejiang Supor Co. Ltd.
Da Mai Yu Development District
Yu Huan 317 604
Zhejiang Province
P.R. China
Telephone: 86 (576) 733 2913 / 3926
Fax: 86 (576) 733 3926 / 2916
E-mail: zjsupor@mail.tzptt.zj.cn

SPECIFICATIONS

Number of syringes per rack (0.5/1.0 ml)	42
Number of syringes per rack (5.0 ml)	2
Number of needles per rack	50
Number of racks included	2
Weight loaded (without water)	[3.5]* kg
Material of sterilizer body	Aluminium
External dimensions (AxBxCxD)	XD22 220 x 135 x 225 x 430 mm XD22A 220 x 135 x 225 x 370 mm

PERFORMANCE

Operating temperature (sea level)	125°C
Power consumption/sterilization:	
electricity:	0.48 kwh
kerosene:	111 ml.
LP gas:	0.56 kg

SPARES NEEDED PER 10 UNITS

	Part No.	Qty	Price/unit
Sealing gasket (silicon white)	--	3	US\$ 1.50
Safety plug	--	2	US\$ 1.50
Depressurisation valve	--	1	US\$ 1.50
Replacement handle	--	1	US\$ 1.50

COMMENTS AND ACCESSORIES

Test reports: BSI EP004595 (1996)

Meets WHO/UNICEF Standard: E9/PS.2, China NHEAC WRc-00-018(March 2000),

Two types of racks are available : 0.1/1.0 & 5ml and 2.0 & 5.0ml. State which rack is required.

A high altitude sterilizer has been developed but has not as yet been independently tested.

The difference between the two models is the handle lengths of 15 (XD22) and 7cm (XD22A) respectively.

Recommendation: To confirm the completion of sterilization cycles, WHO recommends the systematic use of TST strips or spots (E10/06 and 07).

Accessories (syringes and needles not included): carry bag, syringe/needle rack (E9/SR1), 2 spare safety plugs, 3 spare lid seals, plastic bowl for washing syringes, instruction booklet in English (French/Spanish available soon)

2000 PRICES (FOB)

Shipping weight / volume (4 pcs) 18.0 kg / 0.183 m³
Minimum order: 1

Quantity/Price 1/US\$ 45.00

CODE

PIS E9/21

Double rack electric steam sterilizer: Model XKD22-110A

COMPANY NAME AND ADDRESS

Zhejiang Supor Co. Ltd.
Da Mai Yu Development District
Yu Huan 317 604
Zhejiang Province
P.R. China
Telephone: 86 (576) 733 2913 / 3926
Fax: 86 (576) 733 3926 / 2916
E-mail: zjsupor@mail.tzptt.zj.cn

SPECIFICATIONS

Number of syringes per rack (0.5/1.0 ml)	42
Number of syringes per rack (5.0 ml)	2
Number of needles per rack	50
Number of racks included	2
Weight loaded (without water)	4.56 kg
Material of sterilizer body	Aluminium
External dimensions (AxBxCxD)	XKD22 345x225x225x370mm

PERFORMANCE

Operating temperature (sea level)	126°C
Power consumption/sterilization:	
electricity:	1.1 kwh 220V, 50Hz
kerosene:	++.
LP gas:	++

SPARES NEEDED PER 10 UNITS

	Part No.	Qty	Price/unit
Sealing gasket (silicon white)	--	3	US\$ 1.50
Safety plug	--	2	US\$ 1.50
Depressurisation valve	--	1	US\$ 1.50
Replacement handle	--	1	US\$ 1.50

COMMENTS AND ACCESSORIES

Test reports: China NHEAC WRc-00-010 (February 2000),

Meets WHO/UNICEF Standard: E9/PS.3

Recommendation: To confirm the completion of sterilization cycles, WHO recommends the systematic use of TST strips or spots (E10/06 and 07).

Accessories (syringes and needles not included): carry bag, syringe/needle rack (E9/SR1), 2 spare safety plugs, 3 spare lid seals, plastic bowl for washing syringes, instruction booklet in English (French/Spanish available soon)

Warning: Appliance has not yet been tested for 450V spike test.

2000 PRICES (FOB)

Shipping weight / volume (4 pcs) 20 kg / 0.138 m³

Minimum order: 1

Quantity/Price 1/US\$ 198.00

Section E10

Injection accessories

1. Introduction

This section includes accessories for safe sterilization, sterilizer maintenance, and drums that enable sterilized syringes and needles to be transported outside the sterilizer.

- Time, steam and temperature (TST) control indicators

Time, steam and temperature control indicators that must be included in each sterilization cycle to ensure that the sterilization was correctly performed. The indicators must be inspected at the time of use and be available for inspection by supervisors.

- Hard water pads

These are to be used with sterilizers in areas where hard water may damage the sterilizers.

- Sterilizer drums

These drums enable sterilized syringes and needles to be transported outside the sterilizer adding flexibility to a programme.

CODE
PIS
E10/03

Hard water pad:
Model 751300

COMPANY NAME AND ADDRESS

Prestige Medical Ltd.
P. O. Box 154
Off Clarendon Road
Blackburn, Lancashire BB1 9UG, England
Telephone: 44 (1254) 68 26 22
Fax: 44 (1254) 68 26 06
E-mail: customerservices@prestigemedical.co.uk;

SPECIFICATIONS

Number per package	10
Dimensions:	
Diameter	200 mm
Thickness	13 mm
Materials	wire mesh

COMMENTS

Test Report: PHLs (1986), Sprima (1987), University of Lancaster (1988)
(No WHO/UNICEF Standard exists.)
Hard water pad to be used with sterilizers. Each hard water pad individually wrapped in polythene and packed in cardboard carton (10 per carton).

2000 PRICES (FOB)

<i>Shipping weight/vol (10 pcs)</i>	3.9 kg / 0.0082m ³
<i>Minimum order</i>	10 pads

Quantity/Price: 1/GB£ 18.50 (US\$ 26.23)

CODE
PIS
E10/04

Hard water pad:
Model Sanpist 0.7

COMPANY NAME AND ADDRESS

Dac
Direzione Ed Uffici
Via Coralli 14
27100 Pavia
Italy
Telephone: 39 (0382) 52 87 99
Fax: 39 (0382) 52 87 74
E-mail: dac@anthesi.com

SPECIFICATIONS

Number per package	7
Dimensions:	
Diameter	195 mm.
Thickness	28 mm.
Materials	wire mesh

COMMENTS

Test Report: Sprima, November 1987
(No WHO/UNICEF Standard exists)
Shaped edge Aisi 304 stainless steel pad for sterilizers. Each hard water pad is individually sterilized and sealed in a polythene bag.

2000 PRICES (EX WORKS)

<i>Shipping weight/vol (7 pce per box)</i>	4 kg / 0.0086 m ³
<i>Minimum order</i>	14 pads

Quantity/Price: 1/US\$ 20.00

CODE
PIS
E10/06

TST indicator strips

COMPANY NAME AND ADDRESS

Albert Browne Ltd.
Chancery House, 190 Waterside Road,
Hamilton Industrial park, Leicester LE5 1QZ
United Kingdom
Telephone: 44 (116) 276 86 36
Fax: 44 (116) 276 86 39
E-mail: albert.browne@btinternet.com

SPECIFICATIONS

Number per package 50 boxes
(of 100 strips each)
External dimensions 380x170x160
External materials cardboard

COMMENTS

*Test Report: University of Liverpool, June 1988
(No WHO/UNICEF Standard exists.)*
Time, steam and temperature are the three essential criteria for good steam sterilization. The Colour on the indicator strip changes from yellow to blue when in the presence of steam at 121°C for 15 minutes. This colour change will not occur if any of the three parameters are not met.

2000 PRICES (FOB)

Shipping weight/vol (50 boxes) 4 kg / 0.01 m³
Minimum order: 50 boxes (100 strips per box)

Price per box: GB£ 5.67 (US\$ 9.03)
Special prices available for larger quantities.

CODE
PIS
E10/07

TST control spot & Record system for steam ster. working at 121°C for 15'.

COMPANY NAME AND ADDRESS

Albert Browne Ltd.
Chancery House, 190 Waterside Road,
Hamilton Industrial park, Leicester LE5 1QZ
United Kingdom
Telephone: 44 (116) 276 86 36
Fax: 44 (116) 276 86 39
E-mail: albert.browne@btinternet.com

SPECIFICATIONS

Number per carton 50 packs
Content of 1 pack 300 spots
1 record sheet
External dimensions 220x240x70 mm.
External materials cardboard

COMMENTS

*Test Report: University of Liverpool, June 1988
(No WHO/UNICEF Standard exists.)*
Time, steam and temperature are the three essential criteria for good steam sterilization. The Colour on the indicator dot changes from yellow to blue when in the presence of steam at 121°C for 15 minutes. This colour change will not occur if any of the three parameters are not met.

2000 PRICES (FOB)

Shipping weight/vol (50 packs) 2 kg / 0.004 m³
*Minimum order : 50 packs (i.e. 50 x 300 indicators)
50 record systems*

Quantity	Price		
Packs of 300 indicators	GB£	3.34	(US\$ 5.31)
50 record sheets	GB£	27.81	(US\$ 44.26)
Combined package 300 spots + 1 sheet	GB£	3.75	(US\$ 5.97)

CODE
PIS
E10/09

Sterilizer drum

COMPANY NAME AND ADDRESS

Galeno A.M.S S.r.l.
Via Bruno Buozzi, 21
20090 Fizzonasco di Pieve Emanuele
Milan, Italy
Telephone: 39 (02) 90 78 28 21/90 72 44 81
Fax: 39 (02) 90 72 16 63
E-mail: clericie@tin.it

SPECIFICATIONS

Number of needles per drum	50
Number of syringes per drum:	
0.05/0.5 ml	40
5 ml	2
External dimensions (dxh)	210 x 120 mm.
Weight fully loaded	
External material	Stainless steel

PERFORMANCE

Allows complete sterilization of needles and syringes when used with EPI steam sterilizer.

COMMENTS

Test Report: BSI 182180 (1991)
(No WHO/UNICEF Standard exists.)
Can replace the rack in EPI sterilizer.
Allows sterilized syringes and needles to be transported outside of the sterilizer.
Manufacturer has no stocks; to be made on request.

2000 PRICES (EX-WORKS)

Shipping weight / vol (1 pce) 0.9 kg / 0.006 m3
Minimum order: 100

Quantity/Price: ITL 100 000 (US\$ 49.38)

CODE
PIS
E10/10

Sterilizer drum, single rack: Model TD

COMPANY NAME AND ADDRESS

TriSolar Foundation Trust
c/o Orbital Engine Company
1 Whipple Street
Balcatta 6021
Western Australia
Telephone: 61 (8) 94 41 23 21
Fax: 61 (8) 94 41 23 45
E-mail: pewing@orbeng.com.au

SPECIFICATIONS

Number of needles per drum	50
Number of syringes per drum:	
0.05/0.5 ml	42
5 ml	2
External dimensions (dxh)	185 x 125 mm.
Weight fully loaded	
External material	Stainless steel

PERFORMANCE

May be used instead of a sterilizer rack in any of the double rack sterilizers listed in the previous section (E9) -- one drum can fit per sterilizer. Shutters seal the drum after the sterilization cycle. This allows the drum and its sterile contents to be transported to immunization sites, independently of the actual sterilizer.

COMMENTS

Test Report: (No WHO/UNICEF Standard exists.)
Forceps position in lid. Can be made to order to hold other syringes, needles and/or specialized equipment.
Individually wrapped in heavy duty cardboard box.

2000 PRICES (FOB)

Shipping weight/vol (1 pce) 1.25 kg / 0.05 m3
(Delivered to forwarding agent, Perth Airport)
Minimum order: 1

Quantity/Price: US\$120.00
Discounts for orders of +250.

CODE**PIS****E10/11****Sterilizer drum, single rack:
Model ED****COMPANY NAME AND ADDRESS**

TriSolar Foundation Trust
 c/o Orbital Engine Company
 1 Whipple Street
 Balcatta 6021
 Western Australia
Telephone: 61 (8) 94 41 23 21
Fax: 61 (8) 94 41 23 45
E-mail: pewing@orbeng.com.au

SPECIFICATIONS

Number of needles per drum	50
Number of syringes per drum:	
0.05/0.5 ml	42
5 ml	2
External dimensions (dxh)	185 x 120 mm.
Weight fully loaded	
External material	Stainless steel

PERFORMANCE

May be used instead of a sterilizer rack in any of the double rack sterilizers listed in the previous section (E9) -- two drums can fit per sterilizer. Shutters seal the drum after the sterilization cycle. This allows the drum and its sterile contents to be transported to immunization sites, independently of the actual sterilizer.

COMMENTS

Test Report: (No WHO/UNICEF Standard exists.)
 Forceps have to be carried and sterilized separately. Can be made to order to hold other syringes, needles and/or specialized equipment. Individually wrapped in heavy duty cardboard box.

2000 PRICES (FOB)

Shipping weight/vol (1 pce) 1.25 kg / 0.05 m³
 (Delivered to forwarding agent, Perth Airport)
Minimum order: 1

Quantity/Price: US\$ 120.00
 Discounts for orders of +250.

CODE**PIS****E10/12****Sterilizer drum, double rack:
Model TDR****COMPANY NAME AND ADDRESS**

TriSolar Foundation Trust
 c/o Orbital Engine Company
 1 Whipple Street
 Balcatta 6021
 Western Australia
Telephone: 61 (8) 94 41 23 21
Fax: 61 (8) 94 41 23 45
E-mail: pewing@orbeng.com.au

SPECIFICATIONS

Number of needles per drum	104
Number of syringes per drum:	
0.05/0.5 ml	84
5 ml	4
External dimensions (dxh)	185 x 225 mm.
Weight fully loaded	
External material	Stainless steel

PERFORMANCE

May be used instead of a sterilizer rack in any of double rack sterilizers listed in the previous section (E9). Shutters seal the drum after the sterilization cycle. This allows the drum and its sterile contents to be transported to immunization sites, independently of the actual sterilizer.

COMMENTS

Test Report: (No WHO/UNICEF Standard exists.)
 Forceps position in lid. Can be made to order to hold other syringes, needles and/or specialized equipment. Individually wrapped in heavy duty cardboard box.

2000 PRICES (FOB)

Shipping weight/ vol (1 pce) 1.5 kg / 0.05 m³
 (Delivered to forwarding agent, Perth Airport)
Minimum order 1

Quantity/Price: US\$ 150.00
 Discounts for orders of +25

Section E11

Specimen collection equipment

1. Stool specimen collection for AFP

The full procedures describing how to collect a stool specimen are explained in the *Field guide for supplementary activities aimed at achieving polio eradication*. (WHO/EPI/GEN/95.01 Rev. 1) available from the WHO/V&B Document Centre.

2. Send specimens via a “reverse cold chain”

Poliovirus is sensitive to heat: the titre (virus concentration) is maintained at -20°C , but deteriorates when exposed to higher temperatures. The higher the titre, the easier a laboratory can detect the virus. The possibility of detection depends therefore on the original titre, duration and degree of exposure to higher temperatures and the quality of the laboratory. The first two aspects can be influenced in the field by timely collection and correct transport of stool specimens.

After collection, the specimens must be placed immediately in a refrigerator or, for shipment, in a cold box at $0-8^{\circ}\text{C}$ between frozen ice packs. Aim for the specimens to arrive at the laboratory within 72 hours of collection. If this is not possible, the specimens must be frozen (at -20°C) and then shipped frozen, preferably with dry ice or with cold packs that have also been frozen at -20°C . Try to limit repeated freezing and thawing to a minimum. This process of keeping the specimen refrigerated or frozen is called a “reverse cold chain”. If a reverse cold chain is not properly maintained *at all times* during transport, polioviruses will not survive in the stool specimen.

3. Basic rules for specimen storage and transport

- Storage at 0 - 8°C: 3-4 days between collection and arrival at laboratory.
(Check the cold life of the carrier in the Product Information Sheets).
- Storage at -20°C: indefinitely
- Repeatedly freezing and thawing decreases the titre of the sample.
- Avoid storing samples in refrigerators or cold boxes used for vaccines or medicines.
- If separate storage is unavoidable, seal specimens in 2-3 layers of plastic bags and separate them properly from vaccines.
- Disinfect with a solution of 1 part bleach to 10 parts water.
- Inform the receiving laboratory in advance.
- If sending by air, investigate procedures in advance.

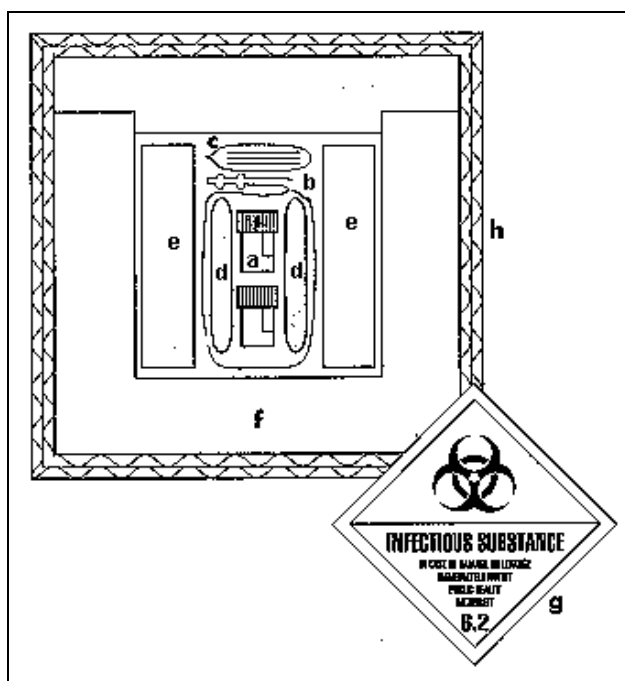

- 30-60 ml faeces container with external screw cap.
- Sealed polyethylene bag to hold faeces containers.
- Sealed polyethylene bag to hold report form.
- Absorbent material (cotton wool absorbs 8-10 times its own weight).
- Icepacks obtainable from national EPI.
- High-density (30-35 kgs/m³) polystyrene (small bubbles and firm when squeezed).
- Infectious substance label.
- Outer carton of double-ply corrugated cardboard or plastic.

CODE
PIS
E11/02

Polio specimen collection kit

COMPANY NAME AND ADDRESS

Medical Export Group
P.O. Box 598
4200 MS Gorinchem, The Netherlands
Telephone: 31 (183) 634 266
Fax: 31 (183) 634 650
E-mail: info@meg.nl

CONTENTS:

Specimen pots	2
Absorbent pad	1
Laboratory form	
in sealed inner bag	1
Patient labels	2
Press sealed outer bag	1

COMMENTS

Test reports: CRL A.9027 (1990)
Samples of this kit can be supplied by WHO/EPI, Geneva on request, free of charge. Purchase direct or through WHO.

2000 PRICES (FOB)

<i>Shipping volume</i>	0.1008 m ³
<i>Weight (package)</i>	10.0 kg.
<i>Number per package</i>	250
<i>External dimensions</i>	600x40x42 cm
<i>Minimum order:</i>	100

Quantity	Price/unit
100 - 10 000	NLG 3.50 (US\$ 1.52)

For larger quantities consult manufacturer

CODE
PIS
E11/05-M

Specimen carrier (Yellow) Model: CFC free

COMPANY NAME AND ADDRESS

Nylex Packaging PTY Ltd.
80 Hartnet Drive
Seaford
Victoria 3198, Australia
Telephone: 61 (03) 92 13 52 22
Fax: 61 (03) 97 86 47 85
Email: sales@nylexpackaging.com.au;

SPECIFICATIONS

Specimen kit capacity	2 kits (E11/02)
Weight fully loaded	5.3 kg.
Weight empty	2.4 kg.
External surface material	Plastic High Density Polyethylene
Internal lining material	Plastic Polypropyl.
Insulation material	Polyurethane
Insulation thickness	50/60 mm.
External dimensions	37x25x35 cm.
Internal dimensions	22x13x20 cm.
Vaccine storage dimensions	12x6x20 cm.
Lid type & fixings	Removable with toggle clips
Number of icepacks required	4
Number of icepacks supplied	4
Icepack type	E5/09
Robustness in drop test:	Fittings 2; Casing 4
Cold life without openings:	48 hours at +43°C

COMMENTS

Test Reports: CRL A.11622 (1996)
Meets WHO/UNICEF Standard E4/VC.2
Replacement foam pads on request.

2000 PRICES (FOB Melbourne)

<i>Shipping weight/vol (1 pce)</i>	2.5 kg / 0.034 m ³
<i>Minimum order:</i>	50

Quantity/Price:	
51-100	1/US\$ 46.31
101-500	1/US\$ 44.00
501-1000	1/US\$ 41.80
1001+	price on application

Section E12

Waste management

1. Introduction

Waste Management is a new product section in the 2000 edition of the PIS. To highlight the importance of injection safety this new section has been introduced. Waste management products previously listed in the E10 Injection accessories section have been moved to this section (and given new codes).

When planning any EPI activity it is vital that the associated costs of waste disposal are incorporated into the budget and training plans.

Waste disposal is a key element of any EPI programme. Poorly managed waste from immunization sessions exposes health workers and the community to infection and injuries.

1.1 Incinerators for wastes from immunization activities.

WHO is currently working on product information for incinerator types that will soon be available at <http://www.healthcarewaste.org>. This will include guidance on decision-making. Below is a brief checklist for programme managers considering introducing incinerators into their programmes.

The suitability of small-scale incinerators depends upon a number of local parameters, which should be assessed before choosing a model. The main parameters include the following:

Human resources

- Skilled workers
- Access to training
- Person-time required to operate the system

Financial and other resources

- Investment and operational costs
- Availability and quality of fuel
- Availability of maintenance materials (is the incinerator built with locally available materials or is it constructed with materials that are not available in the country?)

Technical requirements

- Required treatment capacity (quantity of waste to treat)
- Combustion efficiency for syringes

Environmental and occupational factors

- Smoke and/or toxic products from incinerators
- Safety of operation

Regulatory requirements

- National legal obligations are met

CODE
PIS
E12/01

Safety box for the disposal of used syringes and needles, 5 L

COMPANY NAME AND ADDRESS

Pa-Hu OY
Vattuniemenkatu 25
00210 Helsinki
Finland
Telephone: 358 (9) 682 45 60
Fax: 358 (9) 682 45 62 90
E-mail: myynti@pa-hu.fi

SPECIFICATIONS

Volume	5 litres
Capacity	140 autodis. syr. of 0.5 ml with needles
External dimensions	
Before assembling	590x283x5 mm.
After assembling	290x162x125 mm
Materials	carton
Thickness of walls	1.1-4.4 mm
Weight fully assembled	286 grs
Diam. syringe insert hole	34 mm
Packaging	25 pces per carton - 600x290x125mm - 9kg

COMMENTS

*Test Report: Force Institute 59590/m1460-125 (1996)
Meets WHO/UNICEF Standard E10/IC.2.*
Directions for use on the box in English, French,
Spanish and Russian.

2000 PRICES (FCA Helsinki)

Shipping weight/vol (25 pcs): 9 kg / 0.022 m³
Minimum order: 1000 (40 cartons)

Quantity/Price: per piece 1/US\$ 1.00
Consult manufacturer for larger orders

CODE
PIS
E12/02

Safety box & incineration container for disposal of syringes and needles, 5 L

COMPANY NAME AND ADDRESS

POLYNOR
Tordenskjoldsgt. 13-15
PO Box 13
N-2801 Gjovik
Norway
Telephone: 47 (61) 13 89 30
Fax: 47 (61) 13 84 40
E-mail: polysafe@polynor.no

SPECIFICATIONS

Volume	5 litres
Capacity	155 autodis. syr. of 0.5 ml with needles and caps
External dimensions	
Before assembling	590x272x3mm
After assembling	285x160x130 mm
Materials	recycled board
Thickness of walls	1.4 mm
Weight fully assembled	310.0 grs
Diam. syringe insert hole	35 mm

COMMENTS

*Test Reports: Force Institute 65788/m1460-146 (1996)
and 91530/m1460-190.c (1998) and 128258/ml1460-
284.b (2000)*
Meets WHO/UNICEF Standard E10/IC.1.
Directions for use on the box in English, French,
Spanish and Russian, or other languages on request.
Boxes of 25 pcs. flat packed in robust water resistant
outer carton.

2000 PRICES (EX-WORKS Oslo)

Shipping weight / vol (25 pcs) 9.5 kg / 0.02 m³
Minimum order : 500 (2 weeks delivery time)

Price/unit NOK 7.61 (US\$.85)

CODE
PIS
E12/03

Safety box for the disposal of used syringes and needles, 5 & 10 L

COMPANY NAME AND ADDRESS

CIP Industries
PO Box 1782
Randburg 2125
South Africa
Telephone: 27 (11) 793 44 20
Fax: 27 (11) 793 57 12
E-mail: carpentr@icon.co.za

SPECIFICATIONS (for 5 L)

Volume	5 litres
Capacity	117 autodis. syr. of 0.5 ml with needles
External dimensions	
Before assembling	585x290x7 mm
After assembling	295x165x130 mm
Materials	carton and plastic
Thickness of walls	
external layer	1.6 mm
internal lining	0.8 mm
Weight fully assembled	301.0 grs
Diam. syringe insert hole	35 mm

COMMENTS

Test Report: Force Institute 65065/m1460-142.a (1996).
Meets WHO/UNICEF Standard E10/IC.2
Directions for use on the box in English, French, Spanish, Arabic and Russian. Boxes are equipped with a plastic strap as handle, strong enough to withstand the weight of a fully loaded container.
The 10 L version (US\$ 1.57, discount for > 10 000), also approved by WHO/UNICEF.

2000 PRICES (EX WORKS)

Shipping weight/vol: (375 pcs, 1 pallet) 123 kg/0.606m³
Shipping dimensions 910x610x1093 mm
Minimum order : 10,000

Quantity	Price	
10,000+	US\$	0.86
25,000+	US\$	0.69

CODE
PIS
E12/04

Safety box for the disposal of used syringes and needles, 5 L

COMPANY NAME AND ADDRESS

Danapak Cartons Ltd.
Unit 2, Redbourne Park, Liliput Road,
Brackmills, Northampton NN4 7DT
United Kingdom
Telephone: 44 (1604) 82 70 00
Fax: 44 (1604) 82 77 09
E-mail: sales@claudelyons.co.uk

SPECIFICATIONS

Volume	5 litres
Capacity	110 autodis. syr. of 0.5 ml with needles
External dimensions	
Before assembling	577x283x5 mm
After assembling	285x160x125mm
Materials	carton
Thickness of walls	0.74-2.96 mm
Weight fully assembled	257.0 grs
Diam. syringe insert hole	36mm

COMMENTS

Test Report: Force Institute 65541/m1460-144 (1996).
Meets WHO/UNICEF Standard E10/IC.2
Boxes are equipped with a one finger handle, strong enough to withstand the weight of a fully loaded container.

2000 PRICES (EX WORKS)

Shipping weight / vol (25 pcs) 10 kg / 0.02 m³
Shipping dimensions 490x140x295
Minimum order : consult manufacturer

Price/unit	GB£	0.49	(US\$ 0.80)
Large volumes	consult manufacturer		

CODE
PIS
E12/05

**Needle destroyer - electric:
Model ND2**

COMPANY NAME AND ADDRESS

Healthcare Products Plus, Inc.
2119 North Kenmore Avenue
Chicago IL 60614
USA

Telephone: 1 (773) 528 2652
Fax: 1 (773) 528 9142
E-mail: CBLJLP@aol.com

SPECIFICATIONS

Needle sizes accepted: 30G to 16G
External dimensions 120x127x343mm
Weight 2.32kgs
Materials mild steel, plastic
Diam. syringe insert hole 5 to 22mm
Approx. battery capacity 150 needles
Period to recharge Variable dependent on size and length of needles destroyed.

Comments

Test Report: CA Research and Testing Centre Report A.15274 12/98

Residue non-contaminated non-sharp replaceable cartridge. Cartridge capacity 3,000 to 5,000 needles Must be used immediately at the place and at the time of injection. One destroyer needed for each person injecting simultaneously in the same facility.

2000 PRICES (EX WORKS)

Shipping weight/vol. 5.44 kg /0.0057 m³
Shipping Dimensions 262x115x188mm
Minimum order: 1

Price per unit: US\$ 599.00
Discount for quantity up to 30%

CODE
PIS
E12/06

Needle and Syringe destroyer - manual

COMPANY NAME AND ADDRESS

Balcan Engineering Limited.
Woodhall Spa
Lincolnshire LN10 6RW
United Kingdom

Telephone: 44 (1526) 353 075
Fax: 44 (1526) 352 256
e-mail: destructor@balcan.co.uk

SPECIFICATIONS

Needle sizes accepted: 27G to 18G*
External dimensions 145x78x180mm
Weight 1.73kgs
Materials stainless steel
Diam. syringe insert hole 9mm
Time to destroy 150 needles 14 minutes

Comments

Test Report: CA Research and Testing Centre Report A.15606 03/99

Chops needles into pieces and cuts nibs from syringes to render unusable.

Residue consists of needle particles, contaminated, in re-usable debris pot.

Debris pot and internal guillotine mechanism requires dismantling and disinfection at the end of the session.

Must be used immediately at the place and at the time of injection. One destroyer needed for each person injecting simultaneously in the same facility.

* Manufacturer's tests have shown that needle size 12G can also be cut

2000 PRICES (EX WORKS)

Shipping weight/vol. 1.75 kg /0.0028 m³
Shipping Dimensions 90x155x200mm
Minimum order: 1

Price/unit GB£ 174.50 (US\$ 280.00)
Large quantities consult manufacturer

CODE**PIS****E12/07****Safety box for the disposal of used syringes and needles, 5 L****COMPANY NAME AND ADDRESS**

Atlas Medical Resources (AMR) Corp.
 190 Colonnade Road, Suite 202
 Ottawa, Ontario K2E 7J5
 Canada
Telephone: 1 (613) 228 00 91
Fax: 1 (305) 228 00 92
E-mail: atlasmed@msn.com

SPECIFICATIONS

Volume	5 litres
Capacity	138 autodis. syr. of 0.5 ml with needles
External dimensions	
Before assembling	572x646x5 mm
After assembling	325x135x166mm
Materials	carton
Thickness of walls	1.35 mm
Weight fully assembled	441.0 grs
Diam. syringe insert hole	30mm

COMMENTS

Test Report: Force Institute 123043/m1460-252.a (1999).

Meets WHO/UNICEF Standard E10/IC.2

Boxes are equipped with a handle, strong enough to withstand the weight of a fully loaded container.

2000 PRICES (EX WORKS)

Shipping weight / vol (20 pcs) 9 kg
Shipping dimensions consult manufacturer
Minimum order : consult manufacturer

Price/unit US\$ 0.69

Prices subject to volume discount

CODE**PIS****E12/08****Safety box for the disposal of used syringes and needles, 10 L****COMPANY NAME AND ADDRESS**

POLYNOR
 Tordenskjoldsgt. 13-15
 PO Box 13
 N-2801 Gjovik
 Norway
Telephone: 47 (61) 13 89 30
Fax: 47 (61) 13 84 40
E-mail: polysafe@polynor.no

SPECIFICATIONS

Volume	10 litres
Capacity	326 autodis. syr. of 0.5 ml with uncapped needles
External dimensions	
Before assembling	769x381x2.8mm
After assembling	305x245x150 mm
Materials	recycled board
Thickness of walls	1.4 mm
Weight fully assembled	500.00 grs
Diam. syringe insert hole	35 mm

COMMENTS

Test Reports: Force Institute 128258/m1460-284.c (2000)

Meets WHO/UNICEF Standard E10/IC.2.

Directions for use on the box in English, French, Spanish and Russian, or other languages on request. Boxes of 25 pcs. flat packed and strapped in robust water resistant outer carton.

2000 PRICES (EX-WORKS Oslo)

Shipping weight / vol (15 pcs) 8kg /0.02 m³
Minimum order : (2 weeks delivery time)

Price/unit NOK 12.49 (US\$ 1.40)

CODE**PIS**

E12/09**Safety box for the disposal of used syringes and needles, 20 L****COMPANY NAME AND ADDRESS**

POLYNOR

Tordenskjoldsgt. 13-15

PO Box 13

N-2801 Gjovik

Norway

*Telephone: 47 (61) 13 89 30**Fax: 47 (61) 13 84 40**E-mail: polysafe@polynor.no***SPECIFICATIONS**

Volume	21 litres
Capacity	654 autodis. syr. of 0.5 ml with uncapped needles
External dimensions	
Before assembling	946x463x2.8mm
After assembling	405x285x193 mm
Materials	recycled board
Thickness of walls	1.4 mm
Weight fully assembled	840.0 grs
Diam. syringe insert hole	35 mm

COMMENTS

*Test Reports: Force Institute 128258/m1460-284.d
(2000)*

Meets WHO/UNICEF Standard E10/IC.1.

Directions for use on the box in English, French, Spanish and Russian, or other languages on request. Price includes the printing of client's logo on the box. Boxes of 25 pcs. flat packed in robust water resistant outer carton.

2000 PRICES (EX-WORKS Oslo)

Shipping weight / vol (350 pcs) 335 kg /1 m³

Minimum order : (2 weeks delivery time)

Price/unit NOK 18.20 (US\$ 2.04)

Sections A1 & A2

Equipment for case management of acute respiratory infections

1. The oxygen concentrator

1.1 Introduction

Since publication of the 1997 edition and 1998 supplement of the PIS all the listed oxygen concentrators have gone out of production due to a lack of demand. There are currently no oxygen concentrators on the market that meet the WHO/UNICEF specifications.

WHO is currently carrying out a review of oxygen concentrators in order to assess the currently available products and to review the specifications.

In the meantime, while the review is in progress, it has been decided to include the current products of the previously listed manufacturers (that is, the manufacturers who previously produced products that met the standards) as examples of oxygen concentrators.

Oxygen concentrators are an effective means of supplying oxygen. Traditionally, oxygen cylinders have been the main source of medical oxygen in most developing countries. Oxygen cylinders are heavy, difficult to transport and need reliable distribution systems for necessary refilling of empty cylinders. The cost of oxygen by cylinders is variable depending on transport and service costs in any given area. Although an oxygen concentrator can be expensive to buy, in the long term it can save money.

The concentrator may work 24 hours a day, every day, as long as daily maintenance procedures are carried out. Typically, all that is required is that the user washes a coarse filter each day and replaces three other filters at varying times during the year. Training is required for the routine maintenance. Skilled mechanical maintenance is needed at yearly intervals.

1.2 How does an oxygen concentrator work?

Air contains a mixture of oxygen and nitrogen. An oxygen concentrator separates the oxygen from nitrogen, and increases the proportion of oxygen from about 21% to about 90% (see figure below). There are four filters within the oxygen concentrator, through which the air passes, which get rid of bacteria and dust. The air is forced under pressure through a molecular sieve that binds the nitrogen; oxygen passes through to a reservoir where it is available for use by patients. There are two identical canisters, alternately filling with nitrogen and then emptying when the pressure is released, so that the production of oxygen is continuous.

1.3 Are concentrators reliable?

Oxygen concentrators were first used in the 1960s to provide home oxygen therapy for patients with chronic lung disease. A recent improvement in the design of oxygen concentrators has made them more reliable, smaller, lighter and cheaper. These improvements have made it reasonable to recommend this technology to developing countries that need a reliable source of oxygen.

1.4 What are the WHO/UNICEF test specifications?

An International Standard (ISO) already exists for small concentrators, relating mainly to safety in use. To reach the WHO/UNICEF specification, the machine must first meet the ISO standard and, in addition to this:

- It must be capable of functioning in adverse circumstances, including:
 - ambient temperature of up to 40°C;
 - relative humidity of up to 100%;
 - unstable mains voltage;
 - excessively; dusty environment.
- It must pass military standard shock, vibration and corrosion tests.
- It must be *incapable* of delivering an output oxygen concentration of less than 70%.
- Every machine must be supplied with a comprehensive service manual.
- Every machine must be supplied with 2 years of replacement spares.

An oxygen flow-splitting device should be available so that the oxygen can be given to more than one patient at the same time. The manufacturer is also required to provide evidence of reliability of that piece of equipment.

As stated in the introduction there are currently no concentrators that meet the WHO/UNICEF specifications.

1.5 What are the limitations of use of the oxygen concentrator?

In general, oxygen concentrators have few problems in use but it is important to be aware of a few limitations.

When high humidity is combined with high temperatures the concentration of oxygen may be reduced to 70% because in these circumstances the molecular sieve material adsorbs moisture in preference to nitrogen. Low voltage can also be a problem since this may cause the machine to overheat because the motor is running inefficiently. A voltage regulator should be used in these circumstances. When a flow-splitter is being used, the total flow must not be more than 4 litres per minute or the oxygen concentration will decrease. This happens because the canisters have a defined volume and can only separate a known volume of nitrogen in a given time. Therefore, concentrators must not be used at flows higher than those stated by the manufacturer. Finally, because there is less oxygen in the ambient air at high altitudes, the oxygen flow may be reduced to 80% at 4000 metres, but this should not cause serious difficulties in most cases.

If there is a power failure, the oxygen reservoir inside the machine lasts only 2–3 minutes. Oxygen cylinders are recommended as a back up oxygen supply system in case of power failure.

Small concentrators are not intended or suitable for compressed gas anaesthesia (Boyle's) machines or lung ventilators.

1.6 What kind of maintenance is required?

There are four filters in each of the concentrators. A *coarse filter* that is the outermost filter will need to be washed (with soap and water) and dried at least weekly and in some places daily. The other three filters include the *pre-filter* (changed monthly); *inlet filter* (changed every six months or when the top of the filter is discoloured); and the *bacterial filter* (changed each year). The different concentrator companies have named the filters differently but standard names for the filters can be found in brackets beside the company's filter name. The maintenance of the filters needs to be the responsibility of an individual on a daily basis. Training is required for the nominated responsible. Worn parts on the compressor and valves may need to be replaced, so adequate stocks of spare parts must be included in the initial purchase (check with manufacturers). More technical support will need to be provided occasionally.

1.7 Does the oxygen concentrator need to have an oxygen-sensing device?

Oxygen concentrator technology has improved rapidly and many concentrator companies are including oxygen-sensing devices within the concentrator. WHO/UNICEF recommendations state that concentrators with sensing devices be purchased in countries where there is no other means of checking oxygen concentration. It is also prudent to have an oxygen analyser for periodic checks (once every 3–6 months) of the oxygen concentration to be sure that the sensing device is working properly.

1.8 What will the oxygen concentrator cost?

Prices listed are approximations only. Please contact individual companies directly to get specific prices.

Figure 1: The oxygen concentrator

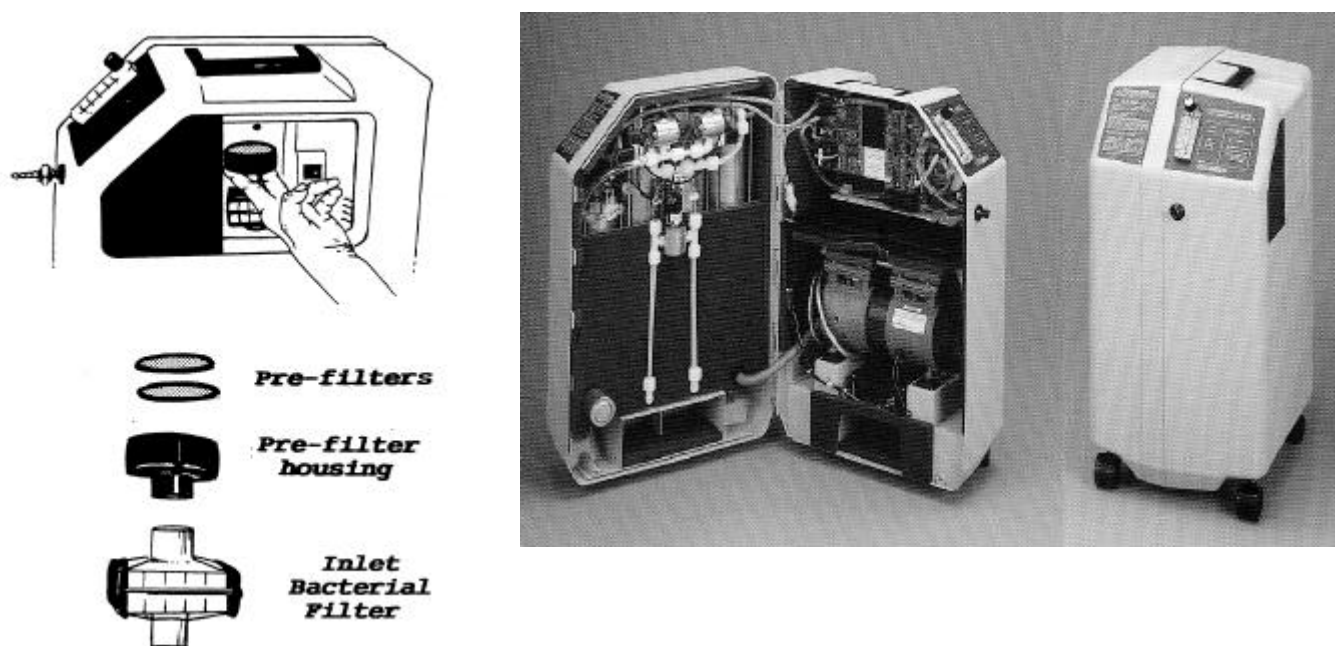

2. Respiratory rate timer

The **respiratory rate timer** is an accurate timing device that enables the respiratory rate of a young child with an acute respiratory infection to be counted for an exact duration of 30 or 60 seconds. The respiratory rate should be counted for 60 seconds (one minute). However, if it is difficult to keep a child (of over two months) calm for 60 seconds. Count for 30 seconds and then double the count to obtain the respiratory rate for 60 seconds.

In infants less than two months of age the respiratory rate is often irregular and should *always* be counted for the full 60 seconds.

CODE

PIS A1/01

Oxygen Concentrator: DeVibiss Model 515 KS

COMPANY NAME AND ADDRESS

Sunrise Medical Ltd (Oxygen department)
Sunrise Business Park
High street, Wollaston
West Midlands, DY8 4PS, England
Telephone: 44 (1384) 44 66 88
Fax: 44 (1384) 44 66 99

SPECIFICATIONS

Dimensions (HxWxD)	70.5x40.6x35.6 cm
Weight:	24.5 kg.
Oxygen concentration measured at the flowmeter	
Temperature	21°C
Relative humidity	50%
Atmospheric pressure	1013 mbar
Flow (LPM)	
1	95% ± 3%
2	95% ± 3%
3	95% ± 3%
4	90% ± 3%
Effect of 7KPA pressure:	Change in flow after 15 minutes; less than 0.1 LPM. No change in product concentration.
Sound level:	47.5 dB(A)
Time taken to reach 95% of the specified performance at 4 litres per minute (21°C 50%RH):	8 minutes

ENERGY REQUIREMENTS

220/240 volts AC 50 Hz mains supply
220/240V AC, 50 Hz 365 W

If mains voltage is expected to vary by more than +10% or -15% a voltage regulator should be used.

SPARES AND ACCESSORIES

Spares provided: Spare filters for approximately two years' use are included in the prices shown.

COMMENTS

This product does not meet WHO/UNICEF Specifications.

Currently there are no oxygen concentrators that meet the WHO/UNICEF specifications. WHO is currently reviewing the specifications and the market.

An oxygen concentrator is an electrical appliance that can provide an uninterrupted supply of oxygen direct from air for clinical and medical applications. Filters are washed, or changed, at recommended intervals that vary according to amount of dust etc. in the surroundings. Inside the concentrator are a Felt Pre-Filter (pre-filter) (changed monthly), an Intake Bacterial Filter (inlet filter) (changed six-monthly or when top of filter is discoloured), and a Final Bacterial Filter (bacterial filter) (changed annually). An external coarse filter is also on the machine. It is washable (at least weekly) and will last indefinitely.

2000 PRICES(FOB)

Shipping Weight / volume 28 kg / 0.187 m³

Item	Quantity	Price/unit
515KS Oxygen Concentrator with oxygen sensing device	1	US\$ 1 150.00

CODE

PIS A1/02

Oxygen Concentrator: Companion Aeris 590 with OCI. Model C-495011

COMPANY NAME AND ADDRESS

Mallinckrodt UK Ltd
 10 Talisman Business Centre
 London Road
 Bicester, Oxon OX6 0JX,
 United Kingdom
Telephone: 44 (1869) 322 700
Fax: 44 (1869) 321 890

SPECIFICATIONS

Dimensions (HxWxD)	(64.5x31.7x41.9) cm
Weight:	(25) kg.
Oxygen concentration measured at the flowmeter	
Temperature	(21)°C
Relative humidity	50%
Atmospheric pressure	101.37 kPa
Flow (LPM) 1 to 4	(95% ± 3%)
1 to 5	(90% ± 3%)

Time taken to reach 95% of the specified performance at 4 litres per minute (21°C 50%RH): 5 minutes

Sound level: Less than (47) dB(A)

ENERGY REQUIREMENTS

220/240 VAC 50 Hz

Power Consumption 390 Watts

If mains voltage is expected to vary a voltage regulator should be used.

SPARES AND ACCESSORIES

Spares provided: Spare filters for approximately two years' use are included in the price shown.

COMMENTS

This product does not meet WHO/UNICEF Specifications (ARI/91.2).

Currently there are no oxygen concentrators that meet the WHO/UNICEF specifications. WHO is currently reviewing the specifications and the market.

An oxygen concentrator is an electrical appliance that can provide an uninterrupted supply of oxygen direct from air for clinical and medical applications. Filters are washed, or changed, at recommended intervals that vary according to amount of dust etc. in the surroundings. Inside the concentrator are a Felt Pad Filter (pre-filter) (changed 6 monthly), and a Bacteria Filter (bacterial filter) (changed annually). An external coarse filter is also on the machine. It is washable (at least weekly) and will last indefinitely.

2000 PRICES (FOB)

Shipping weight / volume (30.8) kg / (0.146) m³

Item	Model No.	Price/unit
Aeris with Oxygen Concentrator Indicator (OCI) (Discounts available for multiple purchases)	C-495011	US\$ 1 450.00

CODE

PIS A1/03

Oxygen Concentrator: Millennium

COMPANY NAME AND ADDRESS

Respironics International
77 rue de Paris
92100 Boulogne-Billancourt
France
Telephone: 33(1) 55 60 19 80
Fax: 33(1) 55 60 19 89

SPECIFICATIONS

Dimensions (HxWxD)	(68.07 x 33.78 x 48.00) cm		
Weight:	(22.68) kg.		
Oxygen concentration measured at the flowmeter			
Temperature	21°C	35°C	43°C
Relative humidity	50%	100%	100%
Atmospheric pressure	1013 mbar	1013 mbar	1013 mbar
Flow (LPM)	1	(94% ± 2%)	<i>data not yet available</i>
	2	(94% ± 2%)	
	3	(94% ± 2%)	
	4	(92% ± 3%)	
	5	(90% ± 3%)	

Time taken to reach 95% of the specified performance at 4 litres per minute (21°C 50%RH):

(3-5) minutes according to altitude. (Altitude up to 2286m)

Effect of 7KPA pressure:

(0.2) LPM, can compensate for flow loss by adjusting flowmeter

Sound level:

50Hz, (45.5) dB(A) at 1 metre ISO 8359

ENERGY REQUIREMENTS

220/240 volts AC 50 Hz mains supply or special voltage/current 230V/60Hz

240V + 10 to 15% VAC 50 Hz 345 Watts, 2 Amps

If mains voltage is expected to vary by more than +10% or -15% a voltage regulator should be used.

SPARES AND ACCESSORIES

COMMENTS

This product does not meet WHO/UNICEF Specifications (ARI/91.2).

Currently there are no oxygen concentrators that meet the WHO/UNICEF specifications. WHO is currently reviewing the specifications and the market.

An oxygen concentrator is an electrical appliance that can provide an uninterrupted supply of oxygen direct from air for clinical and medical applications. Filters are washed, or changed, at recommended intervals that vary according to amount of dust etc. in the surroundings. Inside the concentrator are a pre-filter (washed weekly), an inlet filter (changed six-monthly or when top of filter is discoloured), and a bacterial filter (changed annually). A front filter (external coarse filter) is also on the machine. It is washable (at least weekly) and will last indefinitely.

Supplied with oxygen sensing device with color coded zones (LED) green (normal >85%), yellow (below normal >70%), and red (alarm <70%).

PRICES 2000 (FCA)

Shipping weight / volume (25.5) kg / (0.17) m³

Item	Price/unit
Millennium Oxygen Concentrator with oxygen sensing device	US\$ 890.00
Two spare filters accessories	US\$ 140.00

CODE**PIS A2/01****Respiratory rate timer (ARI Timer)****COMPANY NAME AND ADDRESS**

UNICEF (Denmark)
 UNICEF Plads
 Freeport, DK 2100 Copenhagen 0
 Denmark
Telephone: 45 (35) 27 35 27
Fax: 45 (35) 26 94 21
E-mail: supply@unicef.dk

SPECIFICATIONS

Operating temperature	0 to +50°C
Storage temperature	-10 to +50°C
Timing duration	60 seconds
Timing accuracy	Within 0.1 second
Timing source	Crystal oscillator of 32768 Hz
Packaged	40 per box
Neck cord	Approximately 1 metre long

COMMENTS

The Respiratory Rate Timer has been carefully made to provide a life span of 8,000 counting cycles of 60 seconds under normal usage.

How to use the timer:

- Push the Start/Stop button once. A short "beep" sound will be heard to show that the timer is starting. Actual counting of the respiratory rate must begin as soon this initial beep is heard. Audible clicks will sound every second so that you can be sure that timing is in progress while you continue to observe the patient.
- The timer will give another short beep at the 30 second point of the timing cycle, and two short beeps at the end of 60 seconds when it will automatically shut off. The timer can be stopped at any time during the counting cycle, if needed, by pushing the Start/Stop button once.

Notes on handling:

- Always store the timer in a cool, dry place after use. If the timer is exposed to excessive temperature and moisture, its life span will be shortened.
- If it is necessary to clean the timer, use a moist, clean cloth. Do not use chemicals or detergents as they may damage the unit.

2000 PRICES (FCA)

<i>Shipping weight / volume:</i>	<i>box of 40</i>	<i>2 kg / 0.008 m³</i>
	<i>carton of 5 boxes</i>	<i>10 kg / 0.04 m³</i>
<i>Manufacturer's minimum order:</i>		<i>1 timer</i>

Item	Quantity	UNICEF STOCK Nr	Price
Respiratory rate timer	1 timer	08 450 10	US\$ 3.66

CODE

PIS A2/02

Nebuliser Pump including Spares Kit**COMPANY NAME AND ADDRESS**

Cameron-Price Medical Division Limited
 Charlotte Road
 Stirchley, Birmingham B30 2BT, United Kingdom
Telephone: 44 (121) 459 2121
Fax: 44 (121) 451 2303;
E-Mail info@cameron-price.co.uk

SPECIFICATIONS**Dimensions (H x W x D), packed:**

223 x 340 x 223 mms.

Materials:

Injection-moulded Plastics
 Elastomeric 'O' Ring
 Stainless Steel Spring

ACCESSORIES

One spares kit, containing the following items, supplied with each nebuliser pump.

	Part No (Mfg)	Quantity
Inlet Filter	3031/I	4
Particle Filter	2617/I	4
Special 'O' Ring	2665/I	2
Stainless Steel Spring	4387/I	1

Additional spares kits may be ordered separately:

Weight, packed:

275g

Dimensions (H x W x D), packed:

322 x 102 x 92 cm.

COMMENTS

Test Report: Tested to WHO/UNICEF schedule as detailed in BSI 197426

Meets WHO/UNICEF Test Schedule

A foot pump for driving a nebuliser to deliver liquid medicament air droplets for inhalation.

Instructions for Use in English, French and Spanish included.

2000 PRICES (FCA)

Shipping weight / volume 0.85 kg / 16.9 m³

Minimum Order: 5

Item	Price/unit		
Nebuliser pump including spares kit:	1/GB£	67.30	(US\$ 105.16)
Spares kit:	1/GB£	33.00	(US\$ 51.56)

Section B4

Cold boxes and carriers for blood transport

1. Introduction

The data on blood transport has been compiled by the former Global Blood Safety Initiative and amended by the Blood Safety Unit (now the Blood Safety and Clinical Technology Department) in collaboration with the EPI, on the basis of laboratory tests to determine that the equipment meets WHO/UNICEF specifications.

This is the last edition of the PIS in which blood transport products will appear. The Blood Safety and Clinical Technology Department will be producing a blood products publication by the end of 2000.

All the cold boxes and carriers listed in this section also appear in Section E4 for vaccine transport. The code numbers remain standard with a different prefix to indicate the section – for example, E4/72-M describes the Apex Continental carrier as a vaccine carrier while B4/72-M gives its performance figures as a blood carrier.

Estimation of cold life without openings: In order to arrive at an accurate estimation of cold life for the containers when used to carry blood, one of each category was tested with a blood load. The ratios between the performances with vaccine and blood were then used to calculate the cold life anticipated in the remaining models that have not been tested with a blood load.

Note: The blood storage capacity has been calculated assuming that each unit of blood stands upright.

Warning: It is vital that the instructions supplied by the manufacturers on the handling of blood be strictly observed. Blood should never be brought into direct contact with icepacks, because the blood will be irreversibly damaged. This may cause serious risk to the patient in case of transfusion.

CODE
PIS
B4/05-M



**Large blood cold box, long range:
Model RCW 25/CF(Blue) (991.1510.2)**

COMPANY NAME AND ADDRESS

Electrolux (Luxembourg) SARL
14, op der Hei
L-9809 Hosingen
Luxembourg
Telephone: 352 920 731
Fax: 352 920 731 300
e-mail: Pascal.Vannier@notes.electrolux.lu

SPECIFICATIONS

Blood storage capacity	20 units
Weight fully loaded	47.8 kg.
Weight empty	(15.9) kg.
External surface material	Polyethylene
Internal lining material	Polyethylene
Insulation material	Polyurethane foamed with cyclopentane
Insulation thickness	105 mm.
External dimensions	71x55x50 cm.
Internal dimensions	50x34x27 cm.
Blood storage dimensions	42x26x19 cm.
Lid type & fixings	Hinged
Number of icepacks required	24
Number of icepacks supplied	24
Icepack type	E5/09
Robustness in drop test:	Fittings 2; Casing 5
Cold life without openings	(141) hrs. at 32°C 101 hrs. at +43°C

COMMENTS

*Test report: GET 50361-3300 WI/BO (1995)
Meets WHO/GBSI Standard B4/CB.2
From 1998 this item will be colored in blue, as opposed to yellow previously. When ordering spare parts, please indicate the product number.*

2000 PRICES (FOT Luxembourg)

*Shipping weight/volume (48.3 kg /0.29) m³
Minimum order 1*

Quantity	Price/unit
1-39:	XEU 449.00 (US\$ 273.91)
40-99:	XEU 427.00 (US\$ 263.04)
100+ :	XEU 405.00 (US\$ 255.43)

CODE
PIS
B4/18-M



**Large blood carrier:
Model 3504/38/CF**

COMPANY NAME AND ADDRESS

The Thermos Company
300 North Martingale Road
Schaumburg, Illinois 60173
United States of America
Telephone: 1 (847) 240 31 90
Fax: 1 (847) 240 32 06

SPECIFICATIONS

Blood storage capacity	2 units
Weight fully loaded	5.1 kg.
Weight empty	1.8 kg.
External surface material	Polyethylene
Internal lining material	Polyethylene
Insulation material	Polyurethane
Insulation thickness	40 mm.
External dimensions	24x24x33 cm
Internal dimensions	15x15x19 cm.
Blood storage dimensions	10x10x18 cm.
Lid type & fixings	Removable
Number of icepacks required	4
Number of icepacks supplied	4
Icepack type	Thermos*
Robustness in drop test:	Fittings 3;Casing 3
Cold life without openings	30 hrs. at +43°C

COMMENTS

*Test Reports: CRLA.9000 (1990)
Meets WHO/GBSI Standard B4/BC.1*

2000 PRICES (EX WORKS)

*Shipping weight/volume kg / m³
Minimum order 4*

Quantity/Price: 1/US\$ 19.73

* *Icepacks supplied by Thermos do not meet WHO/UNICEF standards but may be purchased from Thermos at US\$72.96 for 96.*

CODE
PIS
B4/57-M



**Small blood cold box, short range:
Model 55-CF**

COMPANY NAME AND ADDRESS

Blow Kings
53 C Mittal Court ,Nariman Point,
Mumbai – 400 021
India
Telephone: 91(22) 284 01 20 / 284 0393/
282 66 78
Fax: 91 (22) 283 14 12
E-mail: mkothari@giasbm01.vsnl.net.in

SPECIFICATIONS

Blood storage capacity	(10) units
Weight fully loaded	(30) kg.
Weight empty	(9.5) kg.
External surface material	Plastic
Internal lining material	Plastic
Insulation material	Polyurethane
Insulation thickness	55 mm.
External dimensions	46x39x41 cm.
Internal dimensions	34x28x26 cm.
Blood storage dimensions	(28x22x16) cm.
Lid type & fixings	Hinged
Number of icepacks required	24
Number of icepacks supplied	24
Icepack type	E5/12, 19
Robustness in drop test:	Fittings(2);Casing(5)
Cold life without openings	++ hrs. at +32°C (43) hrs. at +43°C

COMMENTS

*Test Reports: Blow Kings (1997) **
Meets WHO/UNICEF Standard E4/CB.4
Supplied with icepack E5/12 of 0.3 liter. Cold life is (49) hrs when E5/19 (0.4 liter) is used.

2000 PRICES (FOB)

Shipping weight/vol (1 pce) 10 kg/0.083 m3
Minimum order 1

Quantity/Price: 1/US\$ 80.00

* *Cold life with blood calculated on basis of tests described in CRL A.9000 which established standard difference between performance with vaccine and blood.*

CODE
PIS
B4/62-M



**Small blood cold box, short range:
Model RCW 12/CF (991 7701 01)**

COMPANY NAME AND ADDRESS

Electrolux (Luxembourg) SARL
14, op der Hei
L-9809 Hosingen
Luxembourg
Telephone: 352 920 731
Fax: 352 920 731 300
e-mail: Pascal.Vannier@notes.electrolux.lu

SPECIFICATIONS

Blood storage capacity	8 units
Weight fully loaded	26.8 kg.
Weight empty	11 kg.
External surface material	Polyethylene
Internal lining material	Polyethylene
Insulation material	Polyurethane foamed with cyclopentane
Insulation thickness	90-115 mm.
External dimensions	50x64x47 cm.
Internal dimensions	29x32x24 cm.
Vaccine storage dimensions	19x26x18 cm.
Lid type & fixings	Hinged
Number of icepacks required	14
Number of icepacks supplied	14
Icepack type	E5/09
Robustness in drop test:	Fittings 2;Casing 1
Cold life without openings	++ hrs. at +32°C 108 hrs. at +43°C

COMMENTS

Test Reports: UNIVALLE E4/3010 (1998)
Meets WHO/UNICEF Standard B4/CB.4
From 1998 this item will be colored in blue, as opposed to yellow previously. *When ordering spare parts, please indicate the product number.*

2000 PRICES (FOT Luxembourg)

Shipping weight/volume (15.6 kg /0.15 m)
Minimum order: 1

Quantity	Price/unit
1-39	XEU 353.00 (US\$ 364.89)
40-99	XEU 335.00 (US\$ 346.81)
100+	XEU 319.00 (US\$ 329.79)

CODE
PIS
B4/72-M



**Large blood cold box, long range:
Model ICBB-13F**

COMPANY NAME AND ADDRESS

Apex Continental Limited
Surya Kiran, 19 Kasturba Gandhi Marg
New Delhi, 110 001 India
Telephone: 91 (11) 331 42 17 /541 14 59
Fax: 91 (11) 371 21 08/546 49 67
E-mail: apexint@mantraonline.com

SPECIFICATIONS

Blood storage capacity	20 units
Weight fully loaded	62.0 kg.
Weight empty	18.6 kg.
External surface material	LLDPE
Internal lining material	LLDPE
Insulation material	Polyurethane
Insulation thickness	100 mm.
External dimensions (WxDxH)	77x62x52 cm.
Internal dimensions (WxDxH)	51x36x27 cm.
Blood storage dimensions	45x30x18 cm.
Lid type & fixings	Hinged
Number of icepacks required	50
Number of icepacks supplied	50
Icepack type	E5/15, 9
Robustness in drop test:	Fittings 3; Casing 2
Cold life without openings	++ hrs. at +32°C 101 hrs. at +43°C

COMMENTS

Test Report: PSB (August 1997).
Meets WHO/UNICEF Standard E4/CB.2
Cold life is 124 hrs when tested with 31 icepacks
E5/09 (0.6 liter)

2000 PRICES (FOB)

Shipping weight/vol (1 pce) 25.4 kg/0.28 m³
Minimum order 1

Quantity/Price: 1/US\$ 183.00

* Cold life with blood calculated on basis of tests described in CRL A.9000 which established standard difference between performance with vaccine and blood.

CODE
PIS
B4/76-M



**Large blood cold box, long range:
Model CB/20/5U-CF**

COMPANY NAME AND ADDRESS

Blow Kings
53 C Mittal Court ,Nariman Point,
Mumbai – 400 021
India
Telephone: 91(22) 284 01 20 / 284 0393/
282 66 78
Fax: 91 (22) 283 14 12
E-mail: mkothari@giasbm01.vsnl.net.in

SPECIFICATIONS

Blood storage capacity	(20) units
Weight fully loaded	(60) kg.
Weight empty	(20.7) kg.
External surface material	Plastic
Internal lining material	Plastic
Insulation material	Polyurethane
Insulation thickness	110 mm.
External dimensions	77x54x55 cm.
Internal dimensions	55x32x33 cm.
Blood storage dimensions	(46x23x19) cm.
Lid type & fixings	Hinged
Number of icepacks required	52
Number of icepacks supplied	52
Icepack type	E5/12, E5/19
Robustness in drop test:	Fittings 2; Casing 5
Cold life without openings	(138) hrs. at +43°C

COMMENTS

Test Report: Blow Kings (1997)
Meets WHO G/B/S/1 standard B4/CB.2
Supplied with icepack E5/12 of 0.3 liter. Cold life is
(147) hrs when E5/19 (0.4 liter) is used.

2000 PRICES (FOB)

Shipping weight/vol (1 pce) 20 kg/ 0.23 m³
Minimum order

Quantity/Price: 1/US\$ 150.00

* Cold life with blood calculated on basis of tests described in CRL A.9000 which established standard difference between performance with vaccine and blood.

Section EC

Equipment for emergency campaigns

1. Introduction

Emergency equipment is equipment to be used when rapid immunization of a large number of people is required in order to intervene in or prevent an epidemic in situations where the local infrastructure is insufficient for an adequate response.

The difference between "normal" and emergency equipment lies not in the type of materials and appliances used, but in their composition. Emergency equipment is focused on rapid intervention, if necessary independent of existing structures.

CODE

PIS EC1/01

IMMUNIZATION KIT: 10 000 INJECTIONS

COMPANY NAME AND ADDRESS

Médécins Sans Frontières Logistique

14 Av. de l'Argonne

33700 Mérignac

France

Telephone: 33 (5) 56 13 73 73

Fax: 33 (5) 56 13 73 74

E-mail: standard@bordeaux.msf.org

CONTENTS OF KIT

Module: REFRIGERATION (KMEDMIMM30)

GUIDE LOGISTIQUE , Logistics of vaccination	1
CONTROL CARD, REFRIGERATION control, Stop Watch	5
CONTROL CARD, TEMPERATURE, twice a day	10
FREEZER, 129 l net, Vestfrost SB202, 220 V.	1
REFRIGERATOR, 84 l net, Vestfrost MK144, 220V.	1
THERMOMETER, ALCOHOL, Moeller 104614 -40° to +50°C	5
EXTENSION CORD, 10 m 3 cond. 2.5 mm2 ext. use +plugs	2
PLUG, male, rubber (2 x 16 A + earth) EUR	1
PLUG, ADAPTOR, male/US, female/EUR	1

Module: COLD CHAIN, TRANSPORT (KMEDMIMM31-)

COLD BOX, VACCINE CARRIER, 1.8 l, Thermos	5
COLD BOX, 22 l, Electrolux RCW25	5
ICE PACK, 0.3 l, Thermos	20
ICE PACK, 0.6 l, Electrolux	120
THERM., ALCOHOL, Moeller 104614 -40° to +50°C	20

Module: LOGISTIC EQUIPMENT (KMEDMIMM33-)

NET, BOUNDARY marking, 1 x 50 m. roll	2
ROPE, diam. 5 mm, POLYPROPYLENE, endless fibers (per meter)	200
TARPAULIN, polyethylene, blue, eyelets, 4 x 5 m, woven	7
CONTAINER, WATER, 20 l collaps., 5 mm cap, food grade plast.	5
TAP for collapsable water container 20 l, screw type 5 mm diam	5
GLOVES, CLEANING, reusable	10
ADHESIVE TAPE, PVC (roll)	5
STATIONARY KIT	1
MEGAPHONE, R6 dry cell x 8/12 V. battery powered	2
BATTERY, dry cell, R6, AA, alkaline, 1.5 V. (14 x 50 mm)	40
BAG, dustbin, plastic, 100 l, black, 70 microns	100

Module: MEDICAL RENEW. SUPPLY (KMEDMIMM34-)

SOAP, 200 g, bar	5
COTTON WOOL, hydrophillic, ROLL, 500 g	10
SYRINGE, autodestruct 0.5 ml, Univec	11000
NEEDLE, disposable, Luer IV, 19 G (1.1 x 40 mm), cream	1000
SYRINGE, disposable, Luer, 10 ml	1000
INCINERATION CONTAINER, 5 l	120
CARD, IMMUNIZ. french/english, untearable, A5, recto/verso	10000
FILE for ampoules	20
GLOVES, PROTECTIVE, disposable, latex, medium	500

Module: MEDICAL EQUIPMENT (KMEDMIMM35)

BOTTLE, plastic, 200/250 ml, with STOUF	5
BRACE, BRACHIAL PERIMETER, (MUAC), PVC, pediatric	15
BRUSH, nail scrubbing, plastic, autoclavable	5
FORCEPS KOCHER, DRESS. 14 cm, straight no teeth, autoclav.	5
KIDNEY DISH, 26 cm x 14 cm, stainless steel	30
SCISSORS, NURSE, 14 cm, straight blunt, autoclavable	5
TRAY, DRESSING, 30 x 20 x 3 cm, stainless steel	30

Kit: GENERATOR, DIESEL, 3.3 KVA, 2700 W, 220V (KPROKGEN33D)

OFFSET COMBINATION WRENCH 10 mm	1
CABLE, GROUNDING, 1 conductor, 6 mm2, ext. use (per meter)	2
EARTH PIN for cable, grounding, length 50 cm	1
EXTENSION CABLE, 3 m+4 outlets (2x16A + earth) Eur. Std.	4
EXTENSION CABLE, 10 m, 3 cond. 2.5 mm2 ext. use +Eur. plug	4
COUNTER, hour, 220 V., for generator	1
GENERAT. DIESEL, 3.3 KVA, 2.7 KW, 50HZ, 220 V Robin	1
AIR FILTER, DY23/27 Robin engine, 243 32600 08	2
FUEL FILTER, DY 23/27 Robin diesel engine, 243 62101 20	5
OIL FILTER, DY 23/27/30/25/41 Robin engine, 243 64301 00	1
FUNNEL, diam. 120 mm	1
JERRYCAN, 20 l, metallic	1
OIL, ENGINE, 15 W 40, petrol & diesel API SF/CE, 5 l, drum	1

COMMENTS

The complete kit, ie all modules, contains the necessary equipment for the rapid immunization of 10 000 people with injectable vaccines by 5 teams. The latter can function independently of the existing infrastructure. The modules can be bought separately, allowing to adapt to the local situation.

Option: MODULE LIGHTING, 1300 W. 4 spotlights 300 W + 12 tubes fluo.
MEGAPHONE KIT
ISOTHERMAL BAG

2000 PRICES (FOB)

Minimum order 1 kit / module

Kit/Module	Code	Price/unit	Shipping weight/volume
COMPLETE KIT	KMEDKIMM3--	XEU 8 867.23 (US\$ 8 061.12)	803 kg / 6.05 m3
REFRIGERATION	KMEDMIMM30	XEU 1 049.97 (US\$ 954.52)	170 kg / 1.28 m3
TRANSPORT	KMEDMIMM31-	XEU 2 802.79 (US\$ 2 547.99)	141 kg / 1.48 m3
LOGISTIC EQUIPMENT	KMEDMIMM33-	XEU 831.00 (US\$ 755.45)	84 kg / 0.58 m3
MED. RENEW. SUPPLY	KMEDMIMM34-	XEU 1 785.23 (US\$ 1 622.94)	272 kg / 1.20 m3
MEDICAL EQUIPMENT	KMEDMIMM35-	XEU 351.00 (US\$ 319.09)	28 kg / 1.00 m3
GENERATOR, DIESEL	KPROKGEN33	XEU 2 047.24 (US\$ 1 861.13)	108 kg / 0.51 m3

Sections P7 & P8

Syringes, needles and accessories for primary health care

CODE
PIS
P7/01

**Electronic mother/child care scale:
Model UNIScale**

COMPANY NAME AND ADDRESS

UNICEF (Denmark)
UNICEF Plads
Freeport, DK 2100 Copenhagen 0
Denmark
Telephone: 45 (35) 27 35 27
Fax: 45 (35) 26 94 21
E-mail: supply@unicef.dk

SPECIFICATIONS

Maximum load	150 kg
Maximum tare	120 kg
Minimum load	1 kg
Accuracy	+/- 100 g
External dimensions:	300x29 x40 mm
Weight:	3.8 kg
Power source:	3.0V lithium battery
Expected life time:	1,000,000 weighing cycles
Switch:	Solar powered
Minimum light required:	15 lux
Maximum humidity:	96%
Operating temperature:	0 - 45 C

COMMENTS

UNIScale is suitable for weighing babies, children, pregnant mothers and other adult people. Weighing babies can be done quickly on health worker's or mother's arms. The scale is lightweight and small, easy to use and needs neither electricity nor servicing. It has a battery for weighing operation, good for one million weighing cycles, and a solar switch to turn the instrument on, i.e. using light.

2000 PRICES (FOB)

Shipping weight / volume (1 pce) 4 kg / 0.006 m³
Minimum order: 1

Quantity/price: 1/US\$ 89.12

CODE
PIS
P8/01

Autodestruct syringe, 2.0 ml

COMPANY NAME AND ADDRESS

Atlas Medical Resources (AMR) Corp
190 Colonnade Road, Suite 202
Ottawa, Ontario K2E 7J5
Canada
Telephone: 1 (613) 228 00 91
Fax: 1 (305) 228 00 92
E-mail: atlasmed@msn.com

SPECIFICATIONS

Vaccine capacity	2.0 ml.
Graduations	0.5 ml
Material of the syringe	Polypro
Fixed needle	23 G x 25 mm.
Prevented from re-use by	Knife attached to plunger cuts syringe body

COMMENTS

Test Report: Semko 554000 (1995)
Meets WHO/UNICEF Standard E8/DS.1 for syringes of 0.5 ml, except for friction.
Meets ISO 7886-1:1993(E) Annex G standard for friction of syringes of 2 ml.

2000 PRICES (FOB)

Shipping weight / volume (100 pcs) 0.98 kg 0.0068 m³
Number of syringes per container 100
Minimum order: 20 containers

Price per container of 100 syringes: US\$ 4.99
Discount available for country program

Index listing by manufacturer

Manufacturer	Equipment	PIS Code	Page
Advance Galatrek	Voltage regulator for compression refrigerators: model FF 500/4R	E7/11	165
Advance Galatrek	Voltage regulator for absorption refrigerators: model FF 500/PA	E7/12	165
Aladdin Sales and Marketing	Cotton wicks for kerosene burners	E7/52	170
Albert Browne Ltd.	TST indicator strips	E10/06	215
Albert Browne Ltd.	TST control spot & Record system for steam ster. working at 121°C for 15'.	E10/07	215
ALMAS	Single rack steam sterilizer: model UAP121	E9/18	207
Apex Continental Limited	Large Vaccine carrier: model IVC-9AF	E4/67-M	126
Apex Continental Limited	Small vaccine carrier: model IVC-8F	E4/68-M	127
Apex Continental Limited	Large vaccine cold box, long range: model ICB-11F	E4/72-M	128
Apex Continental Limited	Small vaccine cold box, long range: model ICB-8F	E4/75-M	128
Apex Continental Limited	Large vaccine cold box, short range: model ICB-14F	E4/86-M	133
Apex Continental Limited	Icepack, 0.3 litre	E5/15	141
Apex Continental Limited	Icepack, 0.4 litre	E5/20	143
Apex Continental Limited	Icepack, 0.6 litre	E5/21	144
Apex Continental Limited	Large blood cold box, long range: model ICBB-13F	B4/72-M	250
Armatherm Gunthel Gmbh	Dial thermometer: model 10 259-04	E6/35	155
Atlas Medical Resources	Autodestruct syringe, 2.0 ml	P8/01	257
Atlas Medical Resources	Safety box for the disposal of used syringes and needles, 5 litre	E12/07	231
Balkan Engineering Limited.	Needle and syringe destroyer - manual	E12/06	230
BD Medical Systems	Autodisable syringe, 0.5 ml Soloshot (TM)	E8/09	187
BD Medical Systems	Autodisable syringe, 0.5 ml Soloshot (TM) FX	E8/17	189
Beijing Light Industrial Prod.	Large vaccine carrier: model IA	E4/34	123
Beijing Light Industrial Prod.	Icepack, 0.4 litre	E5/06	138
Beijing Cold-Chain Co.Ltd	Large vaccine cold box, short range: model LCB-8A	E4/87-M	134
Beijing Cold-Chain Co.Ltd	Icepack, 0.4 litre	E5/22	144
Berlinger & Co. AG	DT & TT shipping indicator	E6/15	151
Berlinger & Co. AG	Vaccine cold chain monitor card	E6/16	152
Berlinger & Co. AG	Freeze watch indicator (0°C): model recorder number:9805	E6/45	159
Berlinger & Co. AG	STOP!WATCH Refrigerator monitor, (0°C)	E6/46	159
BD Medical Systems	Autodisable syringe, 0.5 ml, Soloshot (TM) FX	E8/17	189
Blow Kings	Small vaccine cold box, short range: model 55-CF	E4/57-M	125
Blow Kings	Small vaccine carrier: model VDC-24-CF	E4/69-M	127
Blow Kings	Large vaccine cold box, long range: model CB/20/5U -CF	E4/76-M	129
Blow Kings	Large vaccine carrier: model VC/42/MOD/2/CF	E4/77-M	129
Blow Kings	Small vaccine cold box, long range: model CB/5/2A/CF	E4/78-M	130
Blow Kings	Large vaccine carrier: model BK-VC 1.6 - CF	E4/83-M	132

Manufacturer	Equipment	PIS Code	Page
Blow Kings	Large vaccine carrier: model CB/10-CF	E4/88-M	134
Blow Kings	Icepack, 0.3 litre model BK-V4 H	E5/12	140
Blow Kings	Icepack, 0.4 litre: model BK-4	E5/19	143
Blow Kings	Icepack, 0.4 litre: model BK-6	E5/23	145
Blow Kings	Small blood cold box, short range: model 55-CF	B4/57-M	125
Blow Kings	Large blood cold box, long range: model CB/20/5U-CF	B4/76-M	129
BP Solar Ltd.	Photovoltaic solar refrigerator & icepack freezer: model VR50F	E3/37-M	79
Cameron-Price Medical Div.	Nebulizer pump including spares kit	A2/02	243
Certoclav Sterilizer GmbH	Single rack steam sterilizer: model CertoClav KC 5L, 85.016.05	E9/03	198
Certoclav Sterilizer GmbH	Double rack steam sterilizer: model CertoClav KC 8L, 85.016.08	E9/05	200
CIP Industries	Vaccine carrier for NID: model Frigivac for Kick Polio	E4/84-M	132
CIP Industries	Safety box for the disposal of used syringes and needles, 5& 10 l	E12/03	229
Claude Lyons Limited	Mains voltage compensator for compr. refrig.: model MVC-2W S1775	E7/38	167
Claude Lyons Limited	Mains voltage compensator for absorp. refrig.: model MVC-IN S1776	E7/39	168
CODAN	Sterilizable plastic syringe, 0.05 ml	E8/01	184
CODAN	Sterilizable plastic syringe, 5.0 ml	E8/03	184
CODAN	Sterilizable plastic syringe, 0.5 ml	E8/05	185
Comesse Soudure SA	Solar thermal vaccine refrigerator and icepack freezer	E3/76	88
Dac	Hard water pad: model Sant 0.7	E10/04	214
Danapak Cartons Ltd.	Safety box for the disposal of used syringes and needles, 5 l	E12/04	229
DestroJect GmbH	Autodisable syringe, 0.5 ml: DestroJect	E8/10	188
Dulas Ltd.	Photovoltaic solar refrigerator and icepack freezer: model Dulas VC-150 F	E3/79-M	90
Electrolux (Luxembourg)	Small refrigerator, absorption RCW 42 EG/CF (blue) (P) (920 51 38 01)	E3/21-M	74
Electrolux (Luxembourg)	Small refrigerator, absorption: model RCW 42 EK/CF (blue) (P)	E3/22-M	75
Electrolux (Luxembourg)	Icelined refrigerator, compression: model TCW 1152/CF (920 4251 07)	E3/24-M	76
Electrolux (Luxembourg)	Refrigerator & icepack freezer, electric, compression: RCW 42AC/CF(blue)	E3/30-M	77
Electrolux (Luxembourg)	Photovoltaic solar refrigerator & icepack freezer, compression RCW 42DC/CF(blue)	E3/31-M	78
Electrolux (Luxembourg)	Icelined refrigerator & icepack freezer, compression type: model TCW 1990	E3/62-M	81
Electrolux (Luxembourg)	Icepack freezer, absorption type: FCW 20 EG/CF (blue), electric and gas	E3/72-M	85
Electrolux (Luxembourg)	Icepack freezer, absorption type: FCW 20 EK/CF (blue), electric & Kerosene	E3/73-M	86
Electrolux (Luxembourg)	Icepack freezer, compression:TFW 800 (958.4575.10)	E3/80-M	91
Electrolux (Luxembourg)	Refrigerator and icepack freezer, absorption: RCW 50 EG/CF (blue)	E3/88-M	99
Electrolux (Luxembourg)	Refrigerator and icepack freezer, absorption: RCW 50 EK (blue)	E3/91-M	102
Electrolux (Luxembourg)	Photovoltaic solar refrigerator & icepack freezer, compression RCW 50DC/CF(blue)	E3/93-M	104
Electrolux (Luxembourg)	Refrigerator & icepack freezer, compression type: model RCW 50 AC	E3/94-M	105
Electrolux (Luxembourg)	Vaccine/icepack chest freezer, compression type: model FCW 200	E3/99-M	110

Manufacturer	Equipment	PIS Code	Page
Electrolux (Luxembourg)	Vaccine/icepack chest freezer, compression type: model FCW 300	E3/100-M	111
Electrolux (Luxembourg)	Large vaccine cold box, long range: model RCW 25/CF (blue) (991.1537.01)	E4/05-M	120
Electrolux (Luxembourg)	Small vaccine carrier: model RCW 2/CF (991.5903.01)	E4/53-M	124
Electrolux (Luxembourg)	Small vaccine cold box, long range: model RCW 12/CF (991 7701 01)	E4/62-M	126
Electrolux (Luxembourg)	Small vaccine cold box, short range: model RCW 8/CF (958.4802.01)	E4/85-M	133
Electrolux (Luxembourg)	Icepack, 0.3 litre	E5/08	139
Electrolux (Luxembourg)	Icepack, 0.6 litre	E5/09	139
Electrolux (Luxembourg)	Tool kit for RCW 42 range of refrigerators	E7/37	167
Electrolux (Luxembourg)	gas conversion kit for RCW 42 EK/CF refrigerator & freezer: model no. 991.1861.01/2	E7/42	168
Electrolux (Luxembourg)	Upgrade kit for RCW 42 EK/CF refrigerator & freezer: model no. 991.1860.01	E7/44	169
Electrolux (Luxembourg)	Large blood cold box, long range: model RCW 25/CF (blue) (991.1510.2)	B4/05-M	248
Electrolux (Luxembourg)	Small blood cold box, short range: model RCW 12/CF (991 7701 01)	B4/62-M	249
Englass Disp. & Packaging	Pump dispenser for micronutrients: model Englass Swift "OR"	E8/11	188
Fortum AES Norway AS	Photovoltaic solar refrigerator and icepack freezer: model: CFS49 ISI	E3/70-M	84
Foundrometers Instr. Ltd.	Recording thermometer: model EPI/RFBD	E6/39	157
Galeno A.M.S S.r.l.	Sterilizer drum	E10/09	216
Garnia / Lameplast	Icepack, 0.4 litre	E5/17	142
Gio Style SPA	Icepack, 0.4 litre model 400 CC	E5/10	140
Gio Style SPA	Icepack 0.6 litre	E5/16	142
Gio StyleSpa	Large vaccine carrier	E4/52-M	124
GOK	Manual gas changeover valve: model 02 060-00 (prop. & butane gas)	E7/43	169
H. Jessen Jürgensen A/S	Refrigerator/freezer universal spare parts kits for RCFC-12 or R134A	E7/26	166
H. Jessen Jürgensen A/S	Basic tool kit for refrigerator technician for CFC-12 and HFC-134A systems, 220V**	E7/58	175
H. Jessen Jürgensen A/S	Supplementary refrigerator toolkit for CFC-12 systems only	E7/59	176
H. Jessen Jürgensen A/S	Supplementary refrigerator toolkit for HFC-134A systems only	E7/60	177
H. Jessen Jürgensen A/S	Complete refrigerator Lokring kit AKK110	E7/61	178
Hallcrest Inc.	Waterproof liquid crystal thermometer: model 2290	E6/11	151
Healthcare Products Plus, Inc.	Needle destroyer - electric: model ND2	E12/05	230
Honda Trading Corporation	Medium-light on/off-road motorcycle: model Honda CT110P/DK	E2/09	43
Hyoda Instruments Corporation	Recording thermometer: model AR10-GT-S	E6/28	153
Ina ColdMed	Large vaccine cold box, short range: model CB/INO/B3/90	E4/09	120
Ina ColdMed	Small vaccine cold box, short range: model CB/INO/C2/90	E4/10	121
Ina ColdMed	Small vaccine cold box, short range: model CB/INO/D1/90	E4/20	122
J. Gerber & Company (Japan) Ltd.	Light on-road commuter type motorcycle: model Yamaha V80 (4GC2)	E2/07	41
J. Gerber & Company (Japan) Ltd.	Light on/off-road motorcycle: model Yamaha AG100 (5HS1)	E2/08	42
J. Gerber & Company (Japan) Ltd.	Basic on-road commuter type motorcycle: Yamaha YB100 (3XN1)	E2/12	46

Manufacturer	Equipment	PIS Code	Page
J. Gerber & Company (Japan) Ltd.	Light-Medium on/off road motorcycle: model Yamaha DT 125 (3TT4)	E2/13	47
J. Gerber & Company (Japan) Ltd.	Medium on/off road motorcycle: model Yamaha DT 175 (3TS4)	E2/14	48
J. Gerber & Company (Japan) Ltd.	Medium on/off road motorcycle: model Yamaha AG 200 (3GXE)	E2/15	49
Johnson Level & Tool Manuf.	Surface level: model SM100	E7/08	164
Jules Richard Instruments	Temperature recorder: model 13021.12	E6/38	156
K. Arano & Co. Ltd. (Suzuki)	Light on-road motorcycle: model Suzuki A100 S	E2/10	44
K. Arano & Co. Ltd. (Suzuki)	Light on-road motorcycle: model Suzuki TF125W	E2/11	45
LEC Refrigeration PLC	Ice-lined refrigerator and icepack freezer, compression type: model VC 139 F	E3/64-M	82
Mallinckrodt UK Ltd	Oxygen Concentrator: Companion Aeris 590 Concentrator with OCl: model C-495011	A1/02	240
MSF Logistique	Sterilization Module: 15 l	E9/15	206
MSF Logistique	IMMUNIZATION KIT: 10 000 INJECTIONS	EC1/01	254
Medical Export Group	Polio specimen collection kit	E11/02	223
Möeller-Therm GmbH	Bimetal vaccine thermometer: model 102475	E6/26	152
Möeller-Therm GmbH	Alcohol stem thermometer: model 104614	E6/27	153
Norcoast Refrigeration Co.	Photovoltaic solar refrigerator and icepack freezer: model NRC 30-10	E3/65-M	83
Norcoast Refrigeration Co.	Photovoltaic solar refrigerator and icepack freezer: model 120-30	E3/92-M	103
Nylex Packaging PTY Ltd.	Large vaccine carrier (blue): model: CFC free	E4/81-M	131
Nylex Packaging PTY Ltd.	Specimen carrier (yellow): model: CFC free	E11/05-M	223
OCEASOFT	Temperature data logger: Thermo-tracer	E6/48	160
Oyster Industries (Pvt.) Ltd.	Small vaccine cold box, long range	E4/22	122
Pacific Transducer Corp.	Recording thermometer: model 615.WHO*, 7 day, -40 to +70°C	E6/09	150
Pa-Hu OY	Safety box for the disposal of used syringes and needles, 5 l	E12/01	228
Papeteries Mertens Sprl.	Vaccine packaging tape	E7/10	164
Polyfoam Packers Corp.	Small vaccine cold box, short range: model 390	E4/80-M	131
POLYNOR	Safety box & incineration container for disposal of syringes and needles, 5 l	E12/02	228
POLYNOR	Safety box for the disposal of used syringes and needles, 10 l	E12/08	231
POLYNOR	Safety box for the disposal of used syringes and needles, 20 l	E12/09	232
Prestige Medical Ltd.	Single rack steam sterilizer: model 750900	E9/01	196
Prestige Medical Ltd.	Double rack steam sterilizer: model 750600	E9/02	197
Prestige Medical Ltd.	Triple rack steam sterilizer: model 750500	E9/04	199
Prestige Medical Ltd.	Double rack electric steam sterilizer: model 210005(220/240V)	E9/07	201
Prestige Medical Ltd.	Multi-purpose double rack sterilizer: model 750300	E9/13	204
Prestige Medical Ltd.	Hard water pad: model 751300	E10/03	214
Promociones LISA S.A.	Small vaccine carrier	E4/79	130
Remonsys Ltd.	Temperature data logger: model Tiny TTMTtype G	E6/43	158
Remonsys Ltd.	Temperature data logger: model Tiny TTMG IP68	E6/44	158
Remonsys Ltd.	Temperature data logger: model AUTOLOG 2000	E6/47	160
Respironics International	Oxygen Concentrator: Millennium	A1/03	241
Rueger S.A.	Dial thermometer: model TFH 100 iF 1 + K1.21 + ma	E6/29	154
Rueger S.A.	Vaccine thermometer: model TSH 065 F	E6/30	154
Runsvan AB	Icepack, 0.6 litre (Reference 38095): model 600, Isa Polar Maxi	E5/04	138
Runsvan AB	Icepack, 0.4 litre model reference: 38197	E5/14	141
S. Brannan & Sons Ltd.	Vertical hanging vaccine thermometer: model 66/381/0	E6/08	150

Manufacturer	Equipment	PIS Code	Page
Savopak Oy	Large vaccine cold box, long range: model KR 48	E4/37-M	123
Sedat S.A.	Sterilizable plastic syringe, 0.05 ml	E8/04	185
Sedat S.A.	Sterilizable plastic syringe, 0.5 ml	E8/06	186
Sibir International AB	Refrigerator & freezer, absorption type: model V 170 GE gas and electric	E3/84-M	95
Sibir International AB	Refrigerator & freezer, absorption type: model V 170 KE Kerosene and electric	E3/85-M	96
Sibir International AB	Refrigerator & freezer, absorption type: model V 110 GE gas and electric	E3/86-M	97
Sibir International AB	Refrigerator, absorption type: model V 110 KE Kerosene and electric	E3/87-M	98
Silver Trading Company Ltd.	Fibreglass wick for kerosene burner	E7/13	166
Solamatics	Photovoltaic solar refrigerator & icepack freezer, compression PVR 150	E3/101-M	112
Star Syringe Limited	Autodisable syringe, 0.5 ml	E8/19	190
Star Syringe Limited	Autodisable syringe, 0.05 ml	E8/20	191
Sun Frost	Solar photovoltaic refrigerator / icepack freezer, compression type: RFVB-134a	E3/77-M	89
Sunrise Medical Ltd.	Oxygen Concentrator: DeVibiss model 515 KS	A1/01	239
TATA BP Solar India Ltd.	Photovoltaic solar refrigerator & icepack freezer: model TBP VR 50	E3/83	94
Teck Instruments.	Dial thermometer: model 704 KG 100	E6/36	156
Tempcontrol I.E.P. B.V.	Digital thermometer: model MT 160C	E6/32	155
The Thermos Company	Large vaccine carrier: model 3504 UN/CF	E4/18-M	121
The Thermos Company	Large blood carrier: model 3504/38/CF	B4/18-M	248
TriSolar Foundation Trust	Thermal solar steam sterilizer	E9/14	205
TriSolar Foundation Trust	Sterilizer drum, single rack: model TD	E10/10	216
TriSolar Foundation Trust	Sterilizer drum, single rack: model ED	E10/11	217
TriSolar Foundation Trust	Sterilizer drum, double rack: model TDR	E10/12	217
True Pack Ltd.	Small Vaccine Carrier: model T.P.001	E4/55-M	125
TSS AB	Temperature data logger — TempTale	E6/42	157
UNICEF (Denmark)	Sterilizable syringe Kit A	E8/07	186
UNICEF (Denmark)	Sterilizable syringe Kit B	E8/08	187
UNICEF (Denmark)	Sterilizer Kit A	E9/08	202
UNICEF (Denmark)	Sterilizer Kit B	E9/09	203
UNICEF (Denmark)	Respiratory rate timer (ARI Timer)	A2/01	242
UNICEF (Denmark)	Electronic mother/child care scale: model UNIscale	P7/01	257
UNIVÉC	Autodisable syringe, 0.5 ml	E8/12	189
UNIVÉC	Autodisable syringe, 0.05 ml	E8/18	190
Universidad del Valle	Modification kit to upgrade domestic refrigerators for vaccine storage	E7/51	170
Vestfrost A/S	Icelined refrigerator, compression type: model MK 144 (New Generation)	E3/57-M	80
Vestfrost A/S	Icelined refrigerator, compression type: model MK 074	E3/75-M	87
Vestfrost A/S	Icelined refrigerator, compression type: model MK 204 (New Generation)	E3/81-M	92
Vestfrost A/S	Icelined refrigerator, compression type: model MK 304 (New Generation)	E3/82-M	93
Vestfrost A/S	Vaccine/icepack chest freezer, compression type: model MF 114 (New Generation)	E3/96-M	107

Manufacturer	Equipment	PIS Code	Page
Vestfrost A/S	Vaccine/icepack chest freezer, compression type: model MF 214 (New Generation)	E3/97-M	108
Vestfrost A/S	Vaccine/icepack chest freezer, compression type: model MF 314 (New Generation)	E3/98-M	109
Vestfrost A/S	Basic tool kit for refrigerator technician for CFC-12 and HFC-134A systems, 220V**	E7/54	171
Vestfrost A/S	Supplementary refrigerator toolkit for CFC-12 systems only	E7/55	172
Vestfrost A/S	Supplementary refrigerator toolkit for HFC-134A systems only	E7/56	173
Vestfrost A/S	Complete refrigerator Lokring kit AKK110	E7/57	174
Zero Appliances	Refrigerator & freezer, absorption type: model PR 245 K/E Kerosene and electric	E3/89-M	100
Zero Appliances	Refrigerator & freezer, absorption type: model GR 245 G/E gas and electric	E3/90-M	101
Zero Appliances	Ice pack freezer, absorption type: model PF 230 IP Kerosene and electric	E3/95-M	106
Zero Appliances	Refrigerator & icepack freezer, absorption type: model GR265D	E3/102-M	113
Zhejiang Supor Co. Ltd.	Single rack steam sterilizer: model XS22 and XS22A	E9/19	208
Zhejiang Supor Co. Ltd.	Double rack steam sterilizer: model XD22 and XD22A	E9/20	209
Zhejiang Supor Co. Ltd.	Double rack electric steam sterilizer: model XKD22-110A	E9/21	210