



**White Paper
Blu-ray Disc
Rewritable Format**

**Audio Visual Application Format
Specifications
for BD-RE Version 2.1**

March 2008

Table of Contents

1. Overview	3
2. Recording of Digital Broadcasts	4
2.1. Recording MPEG-2 transport stream of digital broadcast.....	4
2.2. Support of Advanced video codec (MPEG-4 AVC).....	11
2.2.1. AVC Transcode mode	11
2.2.2. HDMV compatible TS mode	11
2.2.3. Interoperability between BDAV and BDMV	12
3. Recording of Analog Broadcasts	13
3.1. Self-Encoded Stream Format (SESF)	13
3.2. Constrained Self-Encoded Stream Format (C-SESF).....	14
4. Direct Recording of DV Input.....	15
4.1. Overview	15
4.2. DV Stream Recording Format	15
4.3. Random Access Method	17
4.4. Minimum Extent Size.....	17
5. User Interface.....	18
6. Editing	23
6.1. Seamless Connection Editing.....	23
6.2. Audio Dubbing	26

BD-RE Part3 "Audio Visual Basic Specifications" Version 2.1

1. Overview

The Blu-ray Disc Rewritable (BD-RE) Application Format consists of: Part-2:File System Standard which defines the format for recording data to disc and the file management system; Part-3:Application Standard which defines the data structure of the file and the mechanism for stream management and user presentation.

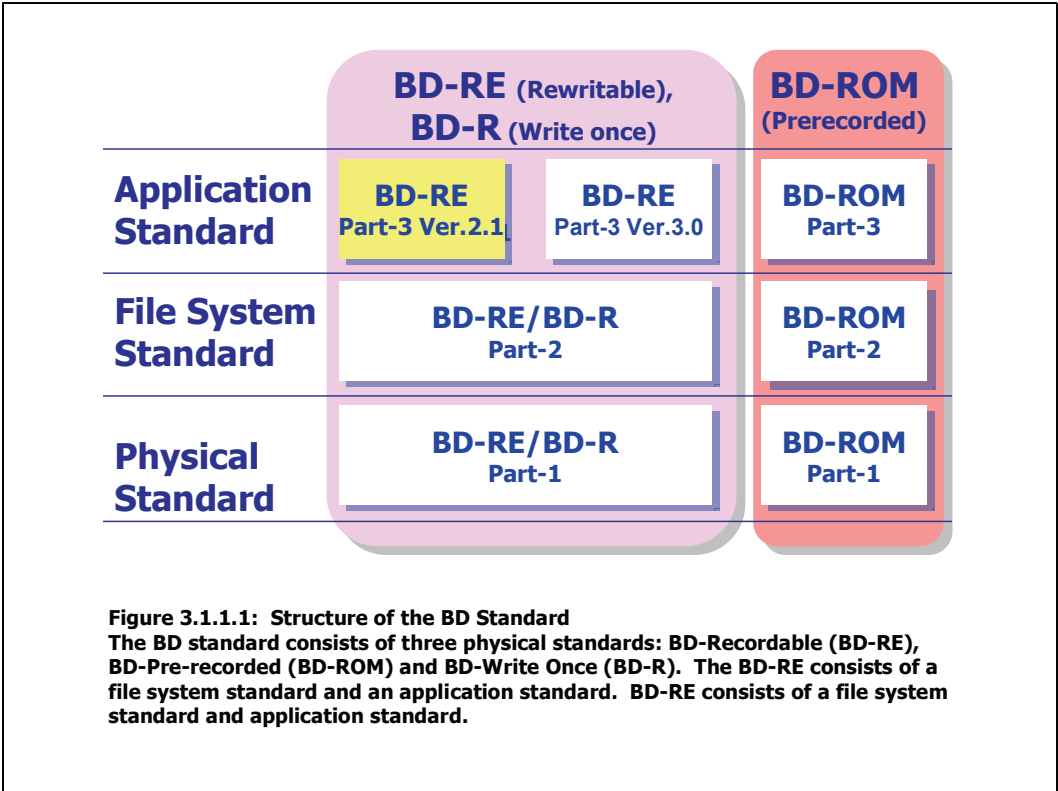

Since the commencement of BS digital broadcasting and digital terrestrial broadcasting in Japan, digital Hi-Vision programs can be enjoyed on several channels and spread to homes in Japan. The BD-RE Part3 "Audio Visual Basic Specifications" Version 2.1 takes advantage of characteristic disc features such as ease-of-use and ease-of-editing and enables BS digital and digital terrestrial broadcasts to be recorded and stored while maintaining the original picture quality. Making full use of the large capacity and high transfer rate of the BD-RE disc, the BD-RE Part3 Version 2.1 has been designed to achieve the following:

- Recording of digital broadcasts including high-vision programming while maintaining the original picture quality—up to 2 hours on a single-layer disc and 4 hours on a dual-layer disc
- Supporting Advanced Video Coding (AVC) for trans-coding of video (MPEG-2 HD video to AVC HD video) and a long time recording mode of digital broadcasting
- Long time recording of analog broadcasts such as standard definition (SD) programs (With a picture quality that is equivalent to that of VHS standard mode, approximately 12 hours can be recorded on a single-layer disc or approximately 24 hours on a dual-layer disc.)
- Seamless, non-destructive editing which takes advantage of disc features

- Direct recording of DV contents from the DV terminal of the camcorder with no picture deterioration (option)
- User interface that supports recorded content management in a visual manner

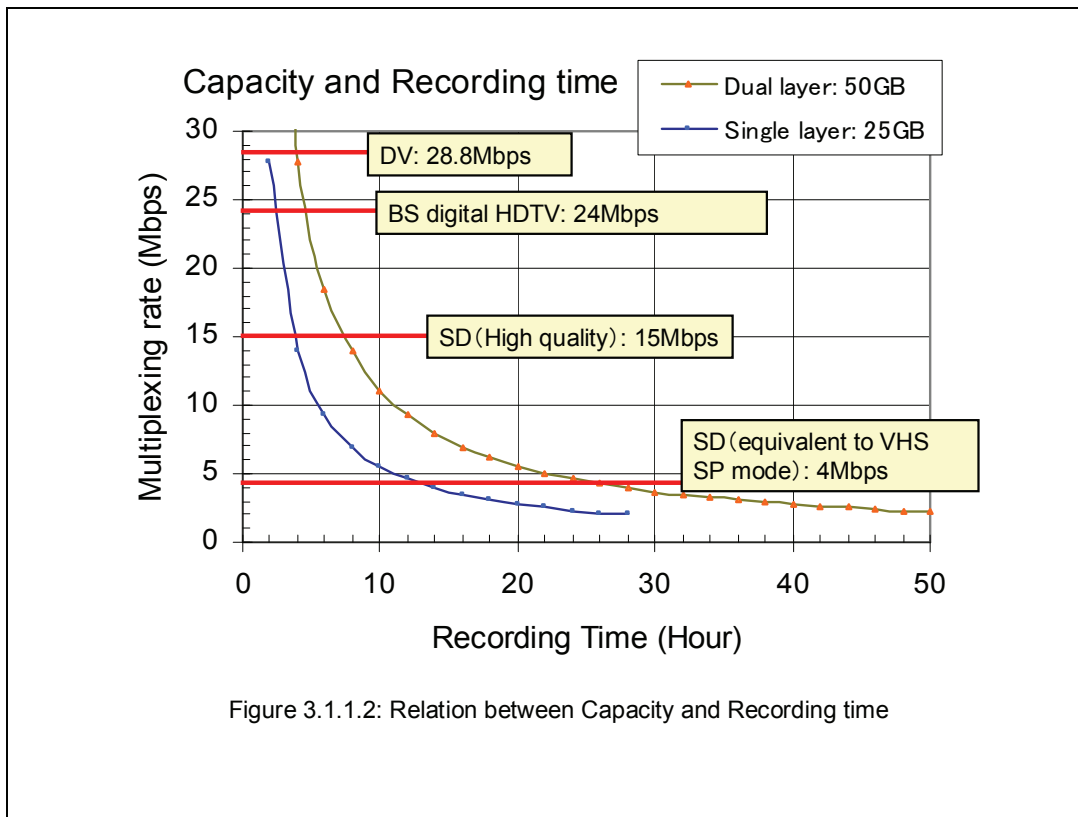

2. Recording of Digital Broadcasts

2.1. Recording MPEG-2 transport stream of digital broadcast

The main characteristic of the recording format under the BD-RE Application Format is its adoption of MPEG-2 TS (Transport Stream) for stream multiplexing.

DVD Video, on the other hand, employs MPEG-2 PS (Program Stream) as its multiplexing format. In comparison with MPEG-2 PS, MPEG-2 TS has a small packet size fixed at 188 bytes; it can multiplex multiple channels and EPG (Electronic Program Guide) information and is altogether more suited to broadcasting. The BD-RE Application Format enables transport streams of digital broadcasts to be recorded as they are without altering the format.

In current BS digital broadcasting systems, a single transponder is occupied by two or four transport streams and multiple programs (that is channels) are multiplexed in a single transport stream. A transport stream like this that is used for broadcasting and contains multiple programs is called a full transport stream (Fig. 3.1.2.1). On the other hand, a partial transport stream is made from the full transport stream by extracting the video/audio/data components of a particular program and reconfiguring the PSI/SI (Program Specific Information/Service Information), information which describes the programs.

(A) ES (Elementary stream) outputted from Encoder

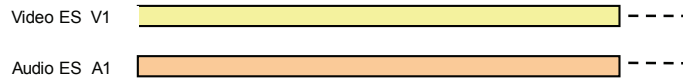

(B) PES (Packetized elementary stream)

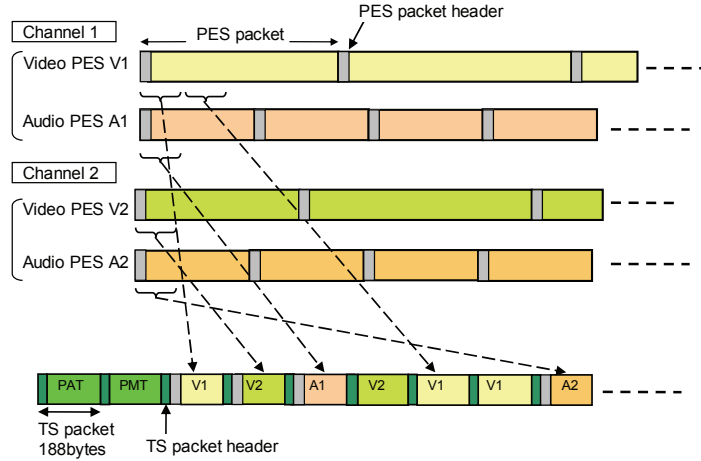

(C) Example of MPEG-2 TS into which Channel 1 and Channel 2 are multiplexed

Figure 3.1.2.1: MPEG-2 Transport Stream that multiple channels are multiplexed

If a digital broadcast recorder were to record a full transport stream in its original form, the video/audio/data components of unwanted channels would also be recorded and use up the recording area. The conversion from full to partial transport stream is an important process for the recorder, as this process lowers the recording rate and allows the recording area to be used efficiently (Fig. 3.1.2.2).

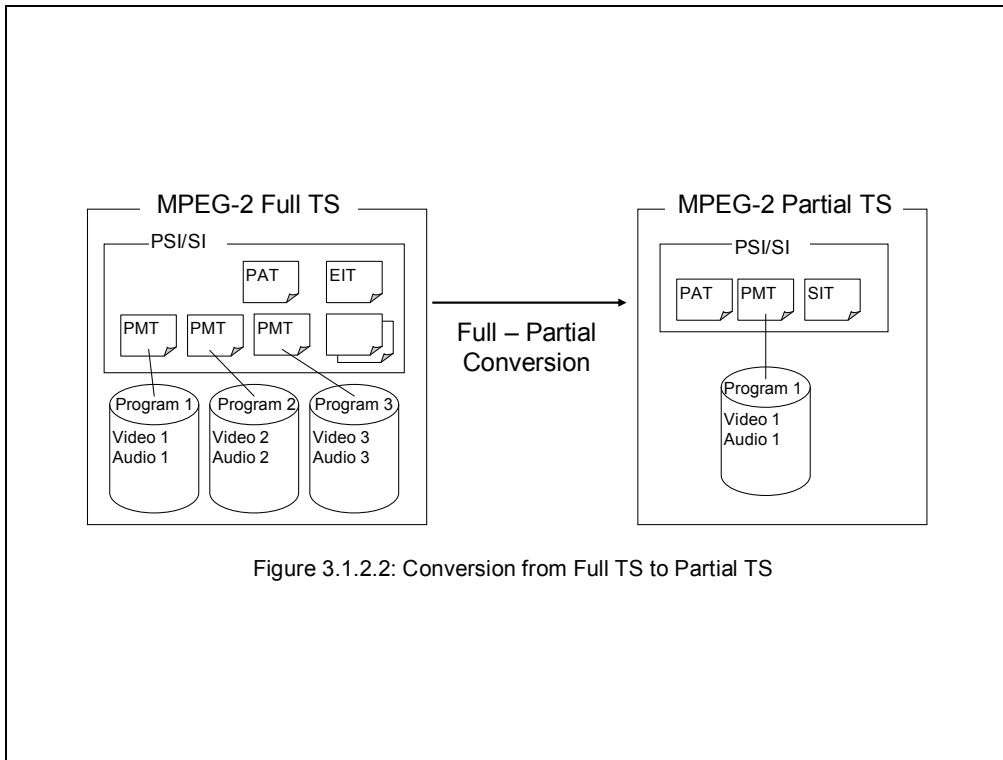

Figure 3.1.2.2: Conversion from Full TS to Partial TS

As shown in Fig. 3.1.2.3, in a partial transport stream which is reconstructed from the necessary packets extracted from the full transport stream, the time intervals between packets are not always the same. These packet intervals are determined by the buffer model and they must be observed when the packets are input to the demultiplexer/decoder or else the buffer will overflow or underflow and data will not be decoded correctly. For this reason, a header is added to each TS packet during recording to indicate the time that the TS packet arrived at the T-STD (Transport stream-System Target Decoder). Under the BD-RE Application Format, a TS packet attached with its packet arrival time is called a source packet. During playback, the packet intervals before recording are reproduced accurately based on the packet arrival times recorded in the source packet headers and the packets are then output to the T-STD or to outside the device (Fig. 3.1.2.4 and Fig. 3.1.2.5).

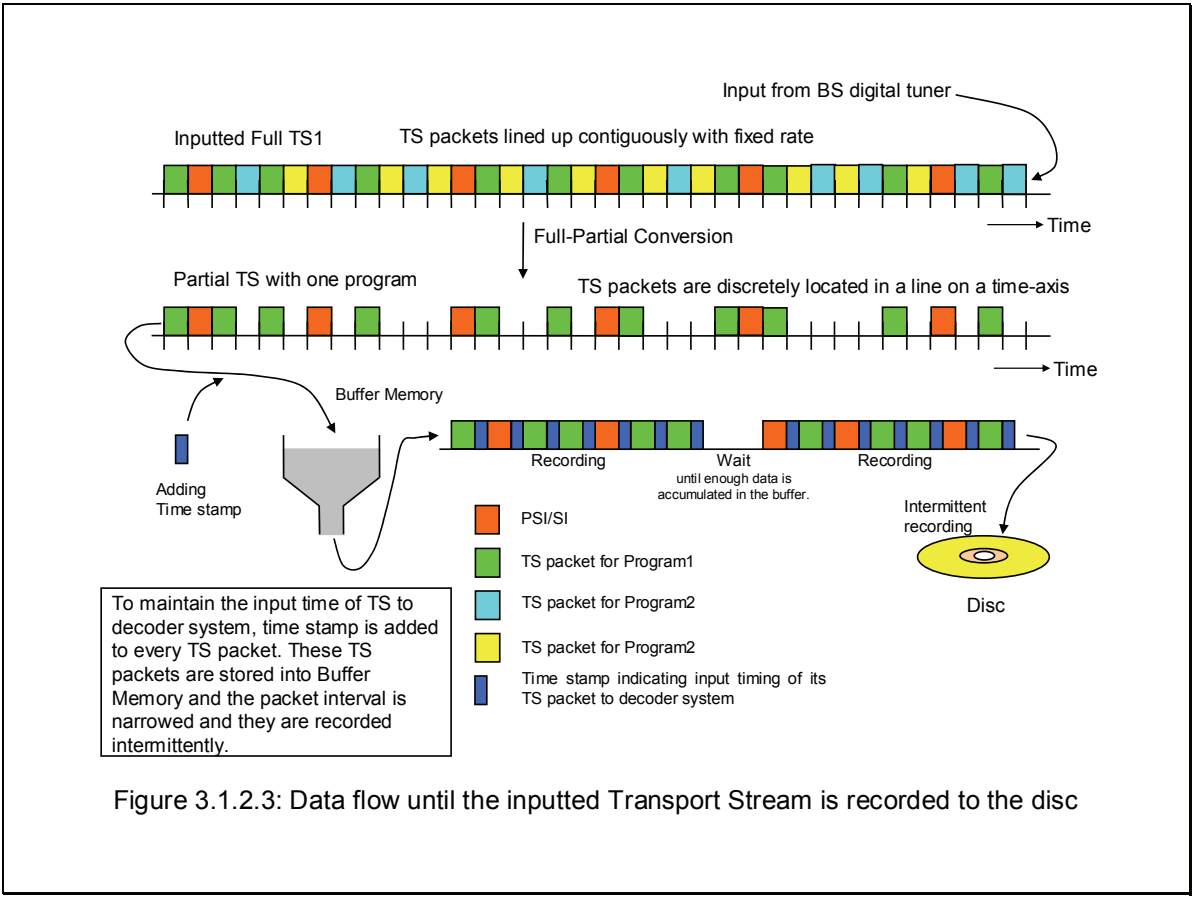
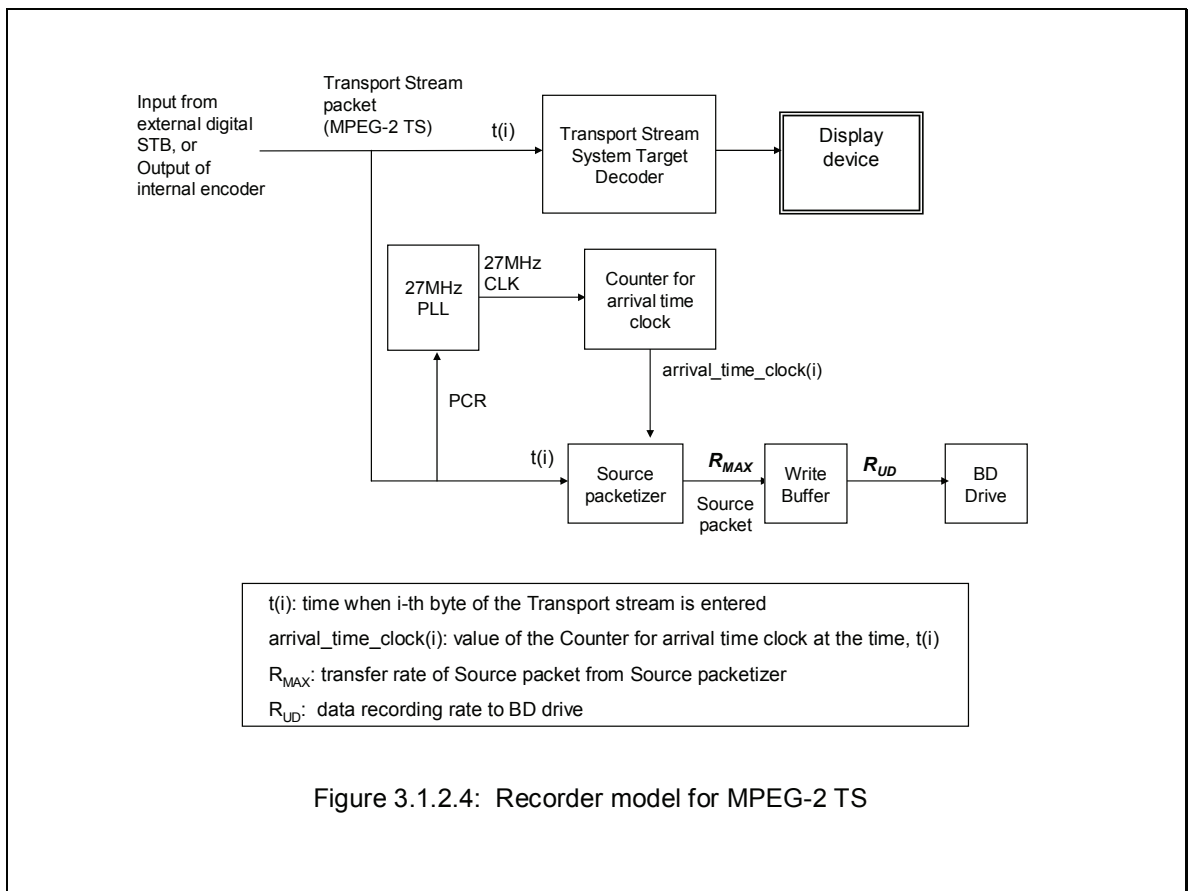

Figure 3.1.2.3: Data flow until the inputted Transport Stream is recorded to the disc



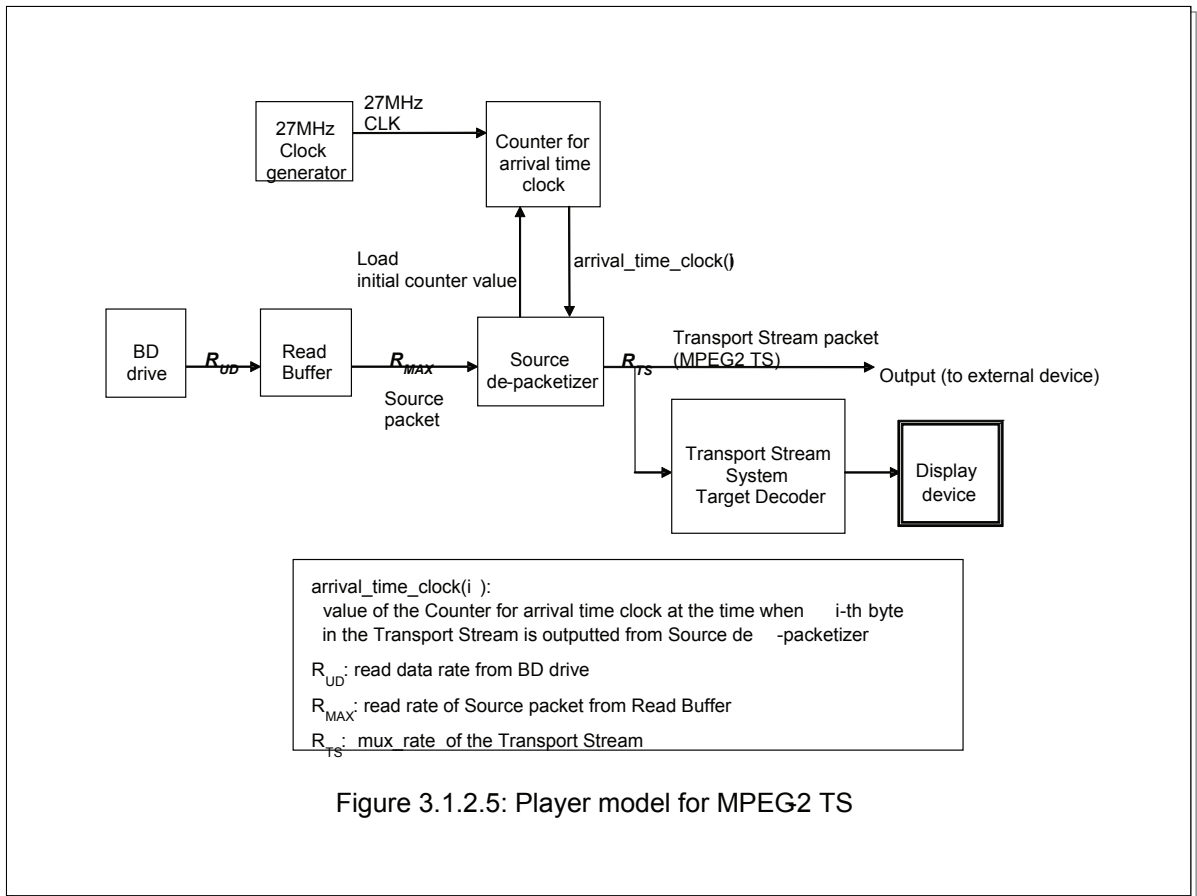

Figure 3.1.2.5: Player model for MPEG2 TS

When recording a transport stream to disc, the information of other programs and other unwanted information are deleted from the PSI/SI and the information reconfigured and the recording is processed in accordance with copy control information; however, no changes are necessary at the coded data level (elementary stream) such as down-converting or re-encoding which affect picture and sound quality. This is how the BD-RE Application Format enables recording of Hi-Vision video, which can have a maximum bit rate of 24Mbps as shown in Fig. 3.1.2.6, and multi-channel audio while keeping the original broadcast quality.

	Profile and Level	Effective number of scanning lines	Horizontal pixel number	aspect ratio	bitrate
Video	MP@HL	1080i	1920, 1440	16:9	24Mbps max
	MP@HL	720p	1280	16:9	24Mbps max
	MP@H14L	480p	720	16:9	24Mbps max
	MP@ML	480i	720, 544, 480	16:9 or 4:3	15Mbps max
Audio	Coding	MPEG-2 AAC LC profile			
	Channel	5.1channel max			
	bitrate	Stereo		144kbps max	
		HiFi stereo (Compression mode B)		192kbps~256kbps	
		Multi-channel		384kbps max	
fs	48kHz, (32kHz is possible for Digital Radio service)				

Figure 3.1.2.6: Video/Audio format of Japanese BS Digital Broadcast

The BD-RE Application Format also supports the recording of BS digital data broadcasts written in BML, a language that is based on XML. A data broadcast is made up of several files and consists of video/audio elements and a program that controls these elements. The files are segmented into sections, a format defined by MPEG-2 TS, and are transmitted repeatedly by the broadcast station in predetermined cycles (data carousel transmission). The receiver obtains one cycle of data beginning from a certain time and extracts the data in its internal memory to restore the files and execute the program. Because the timing of data multiplexing at the time of broadcast is retained under the BD-RE Application Format, the data broadcast is recorded in MPEG-2 TS format without being separated into files.

A convenient feature of digital broadcasting is EPG. The EPG is reconstructed from the PSI/SI multiplexed in the full transport stream: when recording to disc, the necessary information of recorded program is extracted from the PSI/SI and program information is reconstructed in a table called SIT and recorded. This makes it possible to view detailed program information even during playback.

The partial transport stream is also used as the multiplexing format for MPEG-2 streams that pass through i.LINK. Transport streams that are input to the BD-RE recorder from an external digital broadcast receiver via i.LINK can also be recorded without picture/audio deterioration.

In addition to digital broadcasting in Japan, there is DTV in America and DVB in Europe; partial transport stream recording is a highly adaptable recording format which can also be applied to these broadcasting systems.

2.2. Support of Advanced video codec (MPEG-4 AVC)

BD-RE Part 3 version2.1 supports Advanced Video Coding (AVC) for trans-coding of video (MPEG-2 HD video to AVC HD video) and a long time recording mode of digital broadcasting.

BD-RE Part 3 version2.1 has the following two extensions:

- AVC Transcode mode
- HDMV compatible TS mode

2.2.1. AVC Transcode mode

Video elementary stream from the digital broadcast TS is re-encoded to an MPEG-4 AVC video stream, while the other elementary streams (audio streams etc) in the TS keep the original. The re-encoded video stream and the other original streams are remultiplexed. MPEG-4 AVC streams of HDMV compatible TS mode have the same constraint as RREF (Realtime recording and Editing Format) ^(Note1) stated in BD-RE Part3 Version 3.0.

(Note1): The overview of RREF is stated in the “White Paper Blu-ray Disc Rewritable Format Audio Visual Application Format Specifications for BD-RE Version 3.0”.

2.2.2. HDMV compatible TS mode

TS and elementary streams of HDMV compatible TS mode have the same constraint as RREF (Realtime recording and Editing Format) ^(Note1) stated in BD-RE Part3 Version 3.0. In HDMV compatible TS mode, the video elementary stream is re-encoded to MPEG-4 AVC video stream and the audio elementary stream is re-encoded to Dolby AC3 audio or Linear PCM audio.

Elementary streams of HDMV compatible mode

Name of elementary stream	Coding method of elementary stream
Video stream	MPEG-4 AVC video
Audio stream	Linear PCM audio
	Dolby AC-3 audio
Graphics stream	Presentation graphics stream

➤ **AVC Transcode mode of Digital broadcast TS**

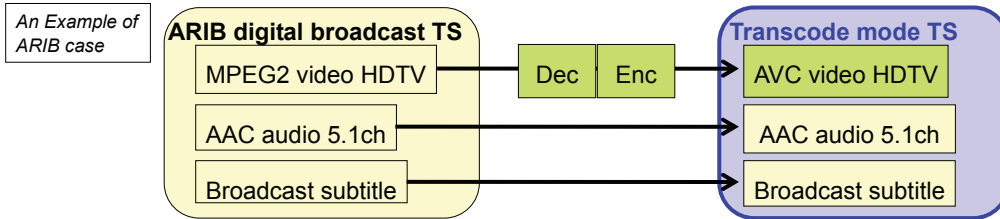

➤ **HDMV compatible TS mode**

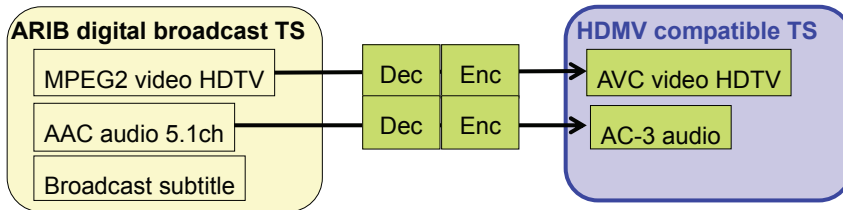

2.2.3. Interoperability between BDAV and BDMV

The HDMV compatible TS mode can realize transforming the BDAV format (BD-RE Part3 Version 2.1) to the BDMV format (BD-RE Part3 Version 3.0) easily. For transforming the HDMV compatible TS of BDAV to the BDMV format, the HDMV compatible TS can be re-used as is, and the BDAV Clip Information file and PlayList files are transformed to the BDMV Clip Information file and PlayList file format.

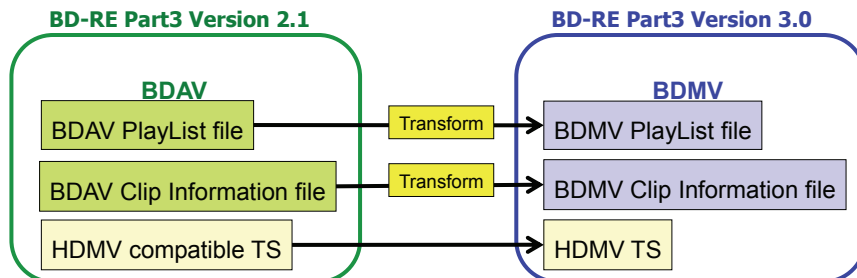

3. Recording of Analog Broadcasts

Although the BD-RE Application Format was designed for recording and playing back high-definition (HD) digital broadcasts, the format is also capable of recording/playing analog SDTV broadcasts, by using the HDMV compatible TS or SESF stated below.

3.1. Self-Encoded Stream Format (SESF)

SESF makes it possible to record/play current analog broadcasts efficiently in addition to HD digital broadcasts, and also guarantees compatibility between BD devices.

SESF conforms to the MPEG-2 TS systems standard (ISO/IEC 13818-1) and is limited to the streams that are required for encoding NTSC (or PAL) video input signals. Thus, the video stream of SESF can be decoded by standard MPEG decoders such as BS digital receivers.

As shown in Fig. 3.1.3.1.1, SESF recorded streams are defined as video, audio and teletext streams.

Video	MPEG-2 video
Audio	MPEG-1 audio Dolby AC-3 audio Linear PCM audio
Teletext	supported for PAL
Tip data	Tip TS

Figure 3.1.3.1.1: Elementary data of SESF

Video streams are encoded in MPEG-2 MP@ML format and recorded on a BD disc.

Video signals with the resolutions shown in Fig. 3.1.3.1.2 and Fig. 3.1.3.1.3 can be used and NTSC and PAL video signals are guaranteed to be recorded at sufficient resolutions. NTSC signals can be recorded at a maximum resolution of 720x480 pixels, which is equivalent to that of DVD packaged media.

720 x 480
704 x 480
544 x 480
480 x 480
352 x 480
352 x 240

Figure 3.1.3.1.2: Resolution under 525/60

720 x 576
704 x 576
544 x 576
480 x 576
352 x 576
352 x 288

Figure 3.1.3.1.3: Resolution under 625/50

SESF provides three types of recording formats for audio streams ranging from a low bit rate to high audio quality, as shown in Fig. 3.1.3.1.4.

CODEC	fs	bits per sample	channel	bitrate
MPEG-1 Layer 2	48 kHz		2 ch	32 kbps – 384 kbps
Dolby Digital	48 kHz		5.1 ch max	64 kbps – 448 kbps
LPCM	48 kHz	16, 20, 24 bits	2 ch	1.536 Mbps – 2.304 Mbps

Figure 3.1.3.1.4: Audio CODEC for SESF

The first audio format is MPEG-1 Layer-2, which is widely used in general consumer equipment (e.g. DTV STB) and is suited to recording at comparatively low bit rates. The Dolby Digital (AC-3) format is the standard used in US satellite broadcasts and DVDs and allows relatively high-quality audio recording. In addition to these two formats, SESF provides a linear PCM format (optional) that supports 2-channel linear PCM recording of up to 48kHz, 24 bits for audio recording of even higher quality than that of existing CD and DVD recorders.

3.2. Constrained Self-Encoded Stream Format (C-SESF)

BD-RE Application Format also allows SESF recording which can be converted to MPEG-2 PS with predetermined simple method and the stream format is called Constrained Self-Encoded Stream Format (C-SESF).

The Constrained SESF handles 11 TS packets as a single unit called a multiplexing unit, shown in Fig. 3.1.3.2.1. A multiplexing unit holds up to 2048 bytes of valid data and can be converted to a program stream and recorded in a 2048-byte sector.

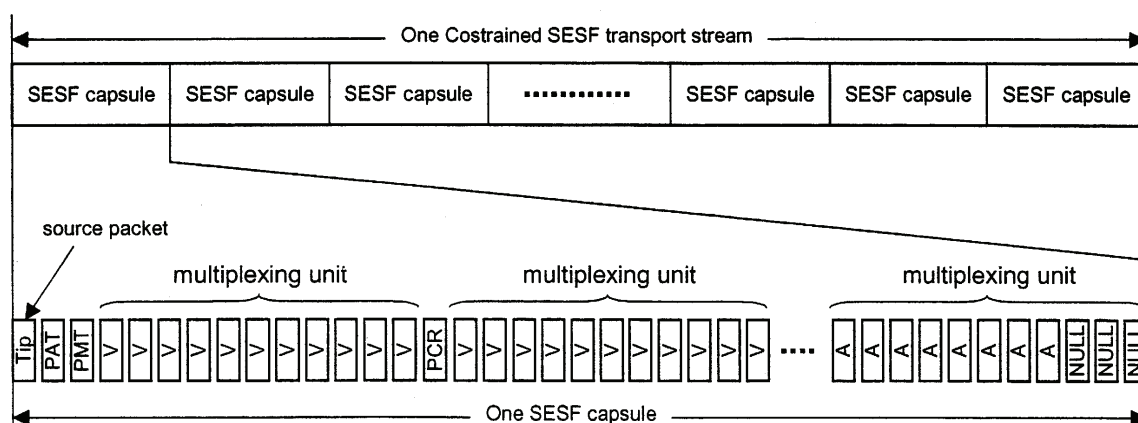

Figure 3.1.3.2.1: Stream of Constrained SESF

An SESF capsule is a grouping of video and audio data that consist of one or more GOPs (Group Of Pictures) and has been designed to enable playback and editing in units of SESF capsules. A Tip packet and PAT, PMT are inserted at the beginning of the SESF capsule.

The Tip packet contains display information such as the aspect ratio of the video data in the stream, CGMS such as the copy control information, and coding information such as the video resolution, and so on. All of this information makes it possible to quickly identify the decoding method before decoding the data.

During skip or high-speed playback, video data can be easily decoded by starting playback from the beginning of the SESF capsule.

4. Direct Recording of DV Input

4.1. Overview

Taking advantage of the BD-RE drive's high user transfer rate (36Mbps), the BD-RE Application Format provides an optional functionality of recording DV streams (28.8Mbps) to BD-RE disc via the i.LINK.

BD recorders that support this functionality enable users to record video material taken with a DV camcorder on BD-RE disc and take advantage of non-linear editing and other functions characteristic of disc media.

4.2. DV Stream Recording Format

The recording format for the DV stream conforms to the DVCR digital interface standard (IEC 61883-2) (Fig. 3.1.4.2.1). The DV stream received through i.LINK is not re-encoded but recorded directly to disc, with aligning the beginning of the DV stream with the logical sector boundary, as shown in Fig. 3.1.4.2.2(a).

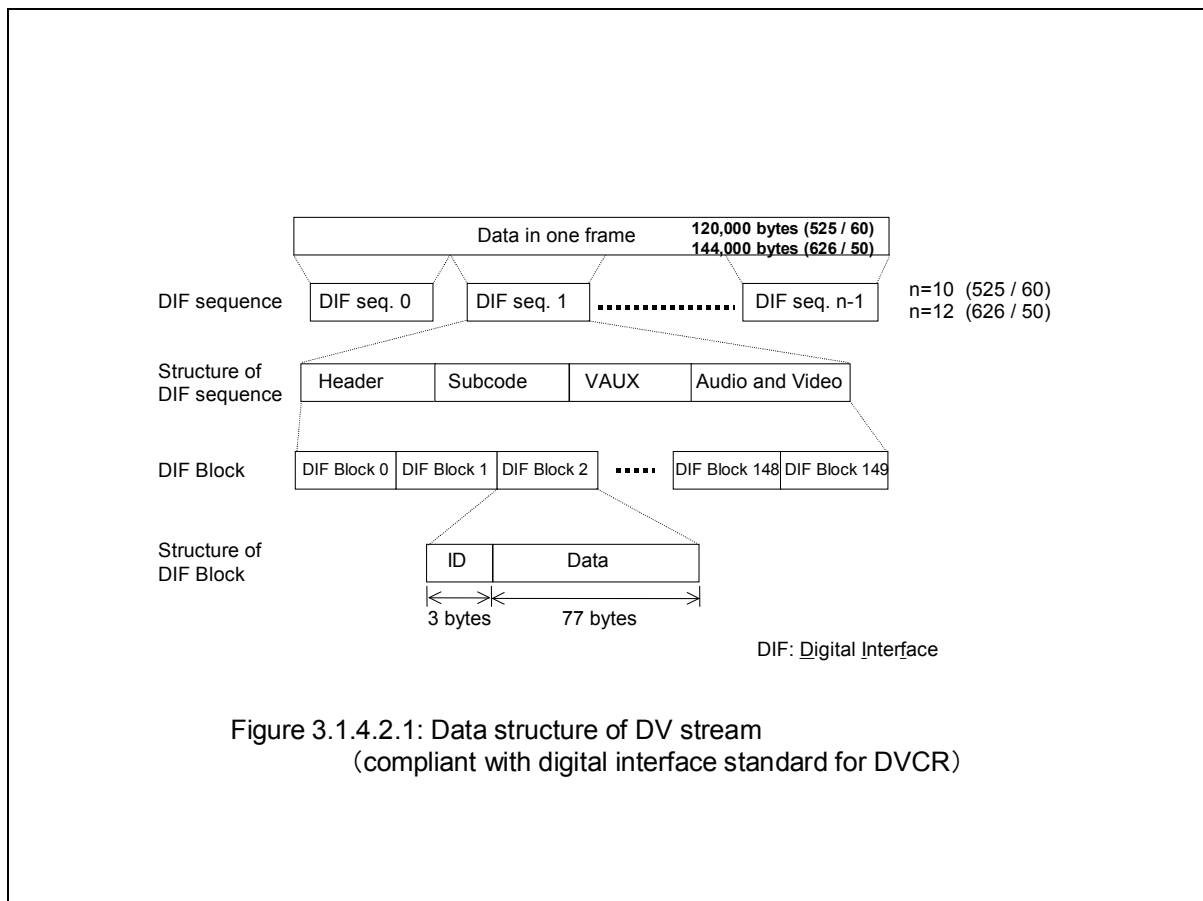

Figure 3.1.4.2.1: Data structure of DV stream
(compliant with digital interface standard for DVCR)

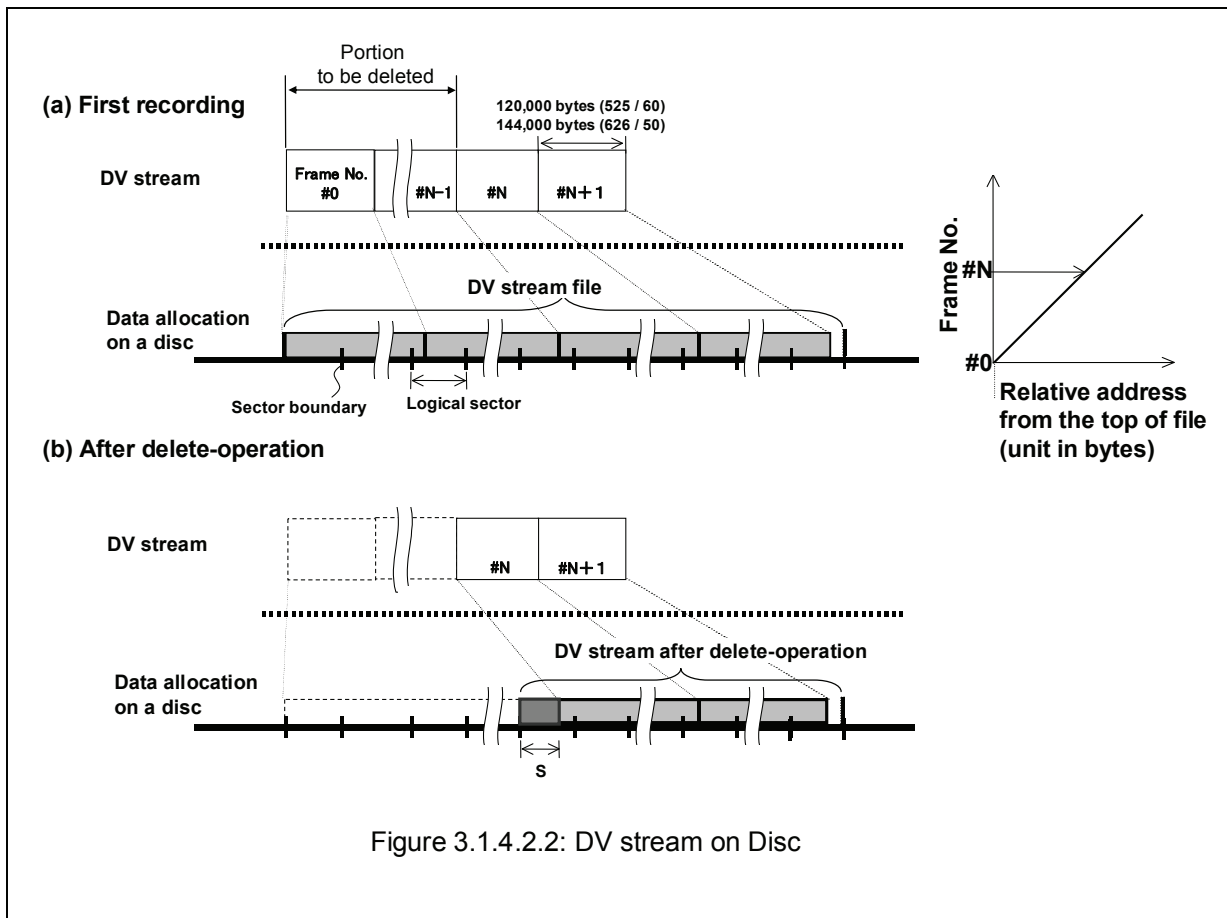

Figure 3.1.4.2.2: DV stream on Disc

Also, as well as MPEG-2 TS recording, a Clip information file in which DV stream property information is stored is created for each stream file. Since the DV stream and MPEG-2 transport stream have different structures, a Clip information file that provides basic information for random access is defined for DV stream. In this way, differences in stream structure are absorbed by the Clip information file so that the PlayList as a top-layer of DV and MPEG-2 TS uses the same data structure.

Fig. 3.1.4.2.3 shows the directory and file structures. DV stream files are stored in the /BDAV/STREAM directory as are TS files. DV stream files have the extension “dvsd” and are accordingly distinguished from TS files. Clip information files and PlayLists are stored in the same directories as for TS files, BDAV/CLIPINF and /BDAV/PLAYLIST respectively.

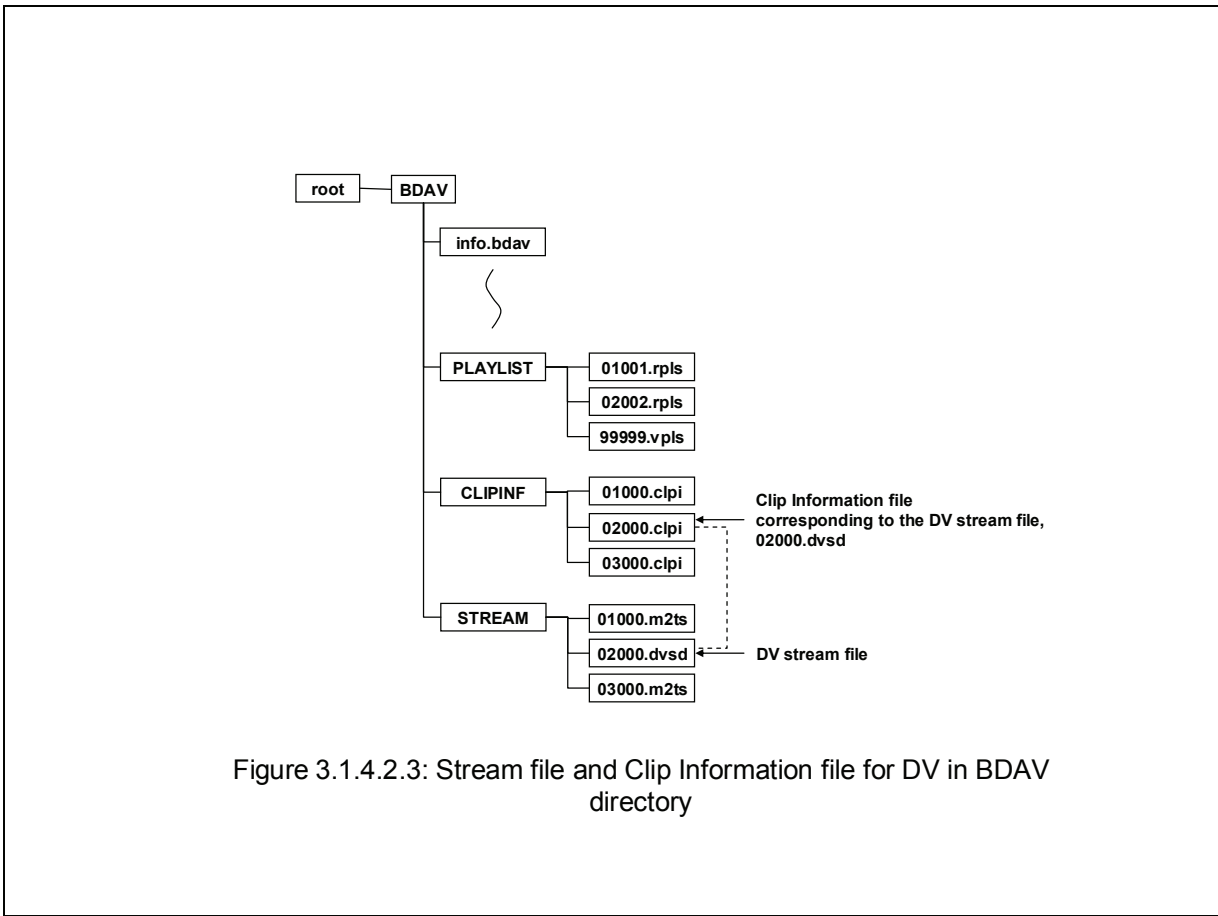

Figure 3.1.4.2.3: Stream file and Clip Information file for DV in BDAV directory

4.3. Random Access Method

Since the video compression method adopted by the DV format is intraframe coding, each frame in the DV stream has a fixed number of bytes (525/60:120,000byte, 625/50:144,000byte). Therefore, the addresses of the frame data corresponding to the playback start and end times specified in the Playlist can be obtained using a simple calculation.

As shown in Fig. 3.1.4.2.2(a), the frame numbers counted from the beginning of the file and their relative addresses are proportional to each other and this relationship can be used to easily obtain the relative address of a random access point.

This is why with the Clip information file for a DV stream there is no need to create a table (CPI) for random access such as EP_map or TU_map (see 3.1.5), which are required for MPEG-2 TS recording.

With linear editing, there may be cases where part of the DV stream file is removed (for instance, frames #0 to #N-1 in Fig. 3.1.4.2.2(a)). Because files are managed in logical sector units by the file system, after part of the file is removed, the beginning of the first frame will be offset from the beginning of new file, as indicated by the dark shade in Fig. 3.1.4.2.2(b). In this case, offset information S and the new top frame number #N are recorded in the Clip information file so that there is no need to shift stream data or add changes to the Playlist.

4.4. Minimum Extent Size

In general, the minimum extent size for recording needs to be defined in order to achieve seamless recording and playback. Because the DV stream has a comparatively high transfer rate of 28.8Mbps,

the minimum extent size must be sufficiently large. The BD-RE Application Format provides for two minimum extent sizes according to stream rate so that streams with a lower transfer rate than the DV stream can be recorded in an efficient manner. Defining the minimum extent size in this way makes seamless playback possible.

If part of a stream is removed, as described above, the stream may end up with sections that do not meet the conditions for contiguous recording required for seamless playback. However, even in this case, seamless playback can be achieved after part of the DV stream is removed by using the bridge sequence described later.

5. User Interface

Fig. 3.1.5.1 shows a conceptual diagram of stream management under the BD-RE Application Format. Stream management consists of two main layers, the PlayList layer and the Clip layer. The PlayList is a unit that represents a grouping of video/audio data to the user. For instance, a sequence of video/audio data from recording start to end constitutes a single PlayList and PlayList construction information is recorded as a single PlayList file. Only the PlayList layer can be seen from the user.

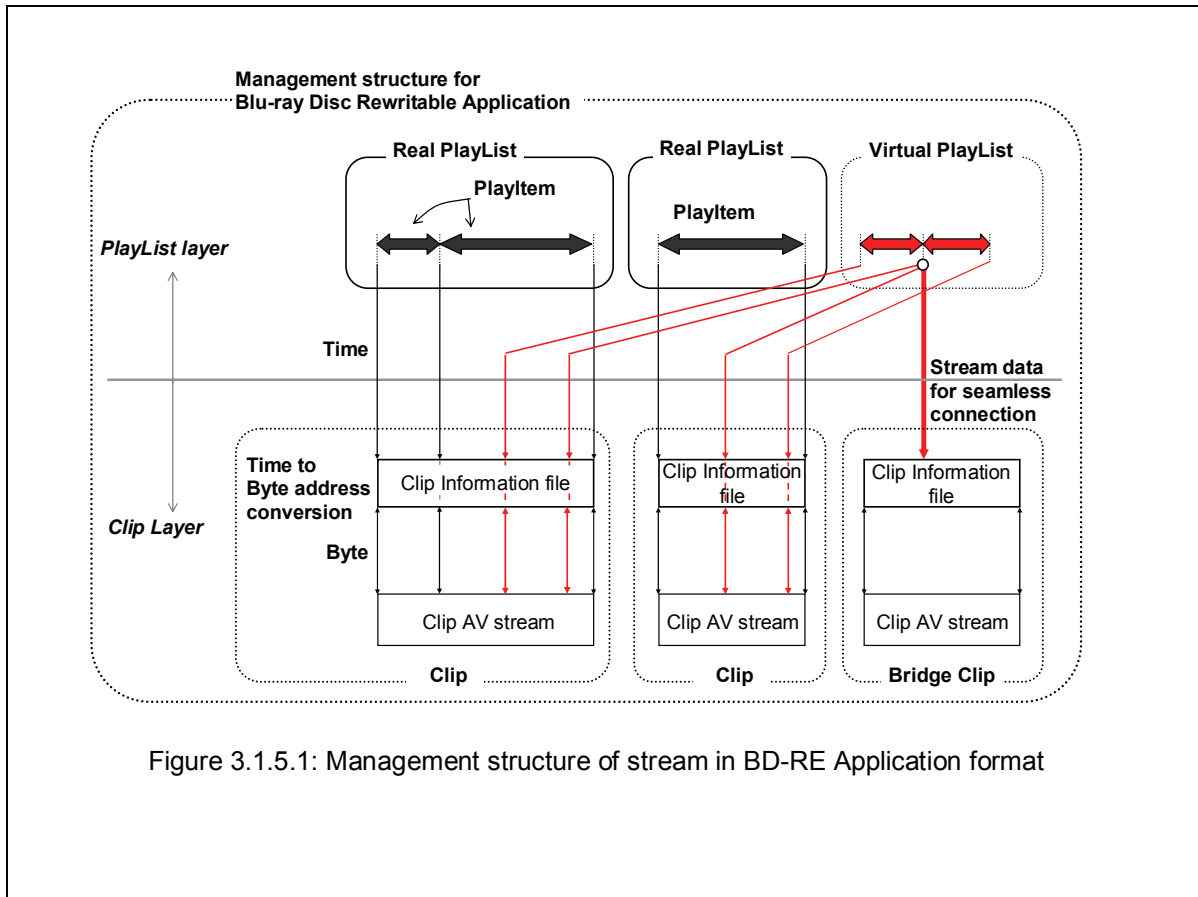

Figure 3.1.5.1: Management structure of stream in BD-RE Application format

The layer below the PlayList layer is the Clip layer which manages AV stream files. The Clip layer consists of AV stream files which store actual video/audio stream data and Clip information files that correspond one to one with Clip AV streams.

The Clip information file is composed of database which contains the information of non-contiguous STC points and program information regarding MPEG-2 TS, and stream's characteristic point

information (CPI), and so on. The CPI is entry point information and is used to achieve high-speed random access and variable-speed playback.

First, the BD-RE Application Format assumed streams to be variable bit-rate MPEG video and defined an EP_map (Fig. 3.1.5.2) to store the byte positions in the file from which decoding can be started, such as the beginning of a GOP. From this table, which defines the relationship between pts and the source packet numbers representing byte positions in the file, the address within the file for a specific time can be known immediately even for VBR (Variable Bit Rate) encoded streams. The BD-RE Application Format also defined a TU_map (Fig. 3.1.5.3) for recording transport streams other than MPEG video.

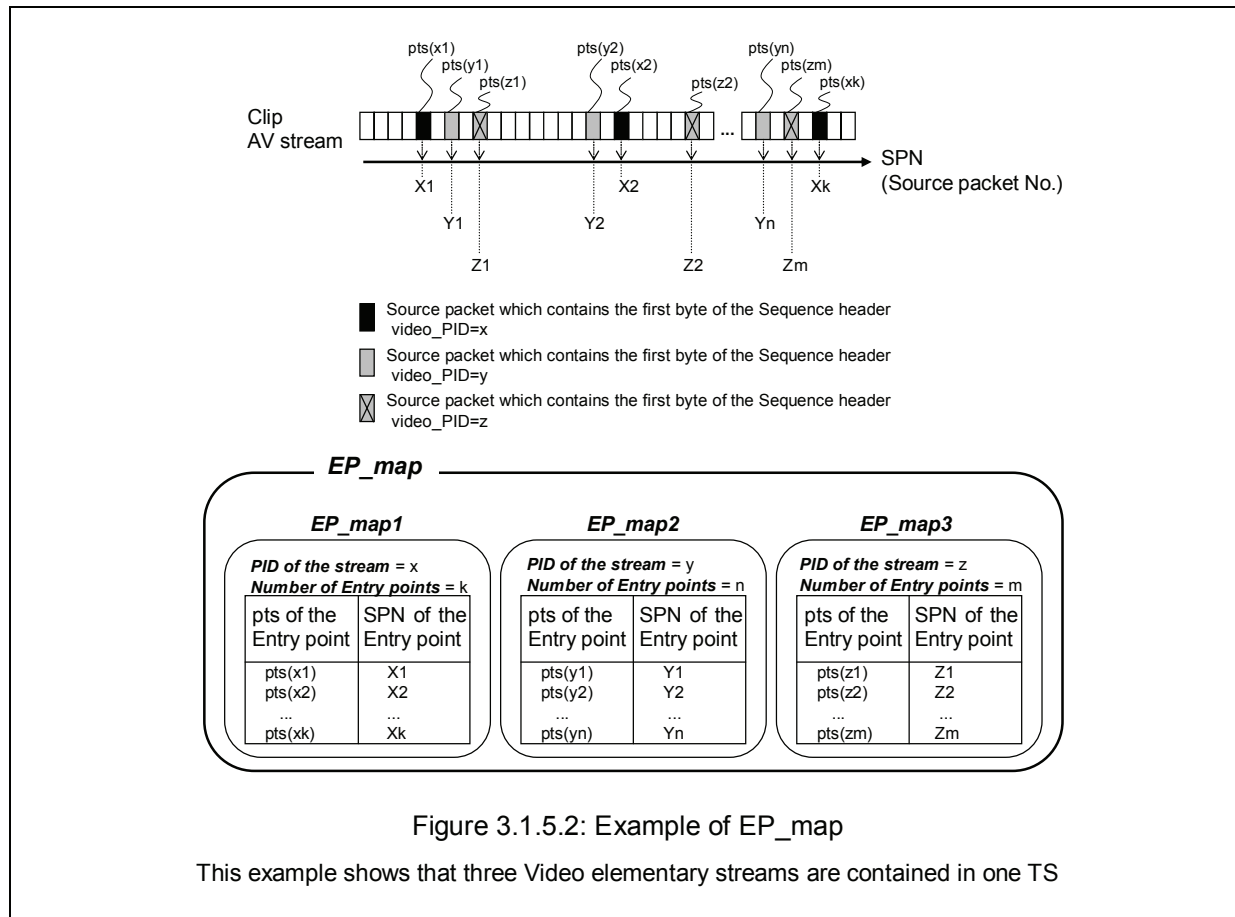

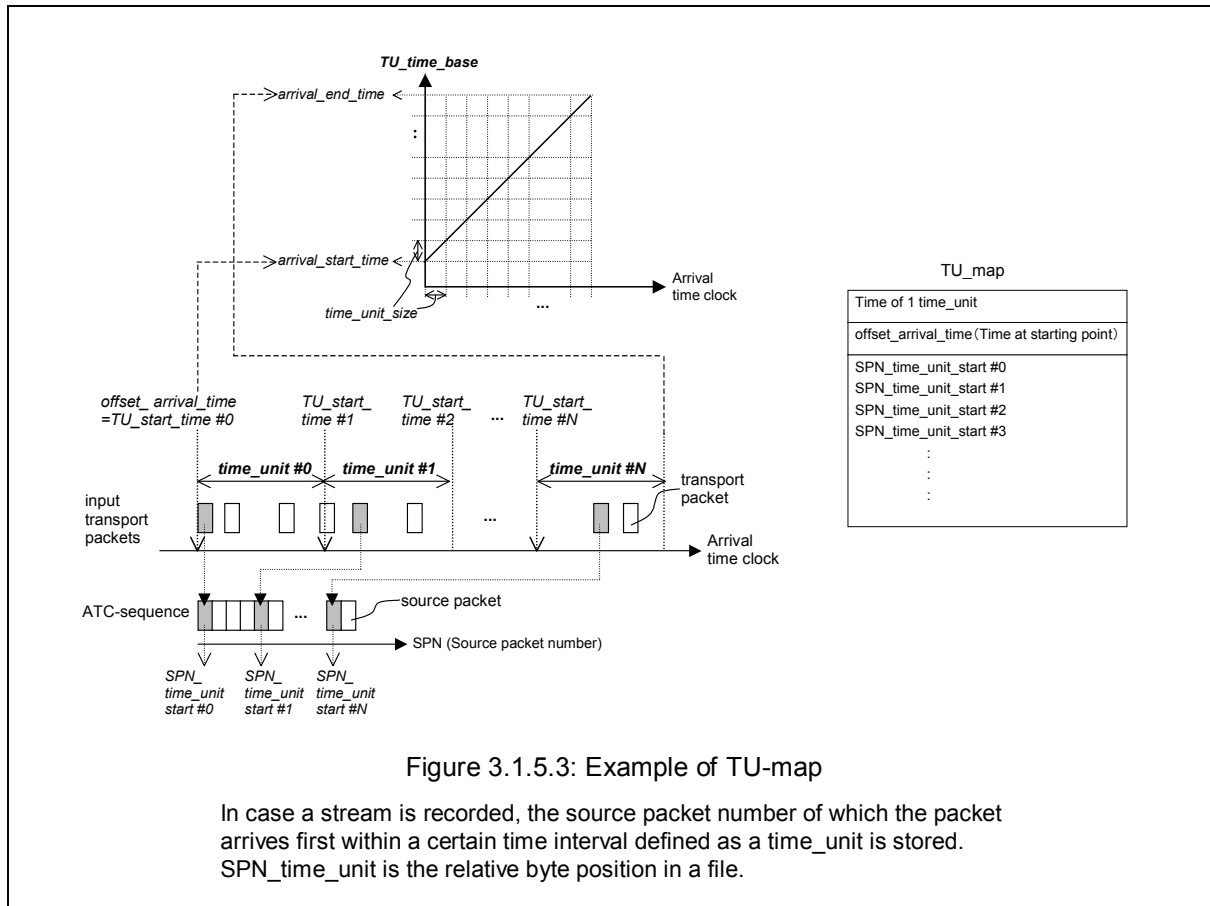

When the TU_map is used, time access is performed in units of time_unit and becomes less precise; however, random access operation of arbitrary transport streams becomes possible. The EP_map together with the TU_map are called CPI. These databases are created by the recorder when it records the stream.

The Playlist is a sequence of play-items. A play-item is a set of IN, OUT points that represent the playback time range within a Clip. PlayLists are created automatically whenever a new recording is made; these PlayLists are called real PlayLists. "Real" indicates that the Playlist is created one to one with a Clip at the same time as the Clip is recorded.

PlayLists can be generated by editing operations in addition to when new recordings are made. One method of editing is to add a change such as divide, combine, or delete (Fig. 3.1.5.4) to an existing Playlist. Editing may result in many-to-many relations between real PlayLists and Clips but the valid part of the clip is always referenced by a real Playlist. Deleting a real Playlist means the Clips which the Playlist refers to are also erased from the disc.

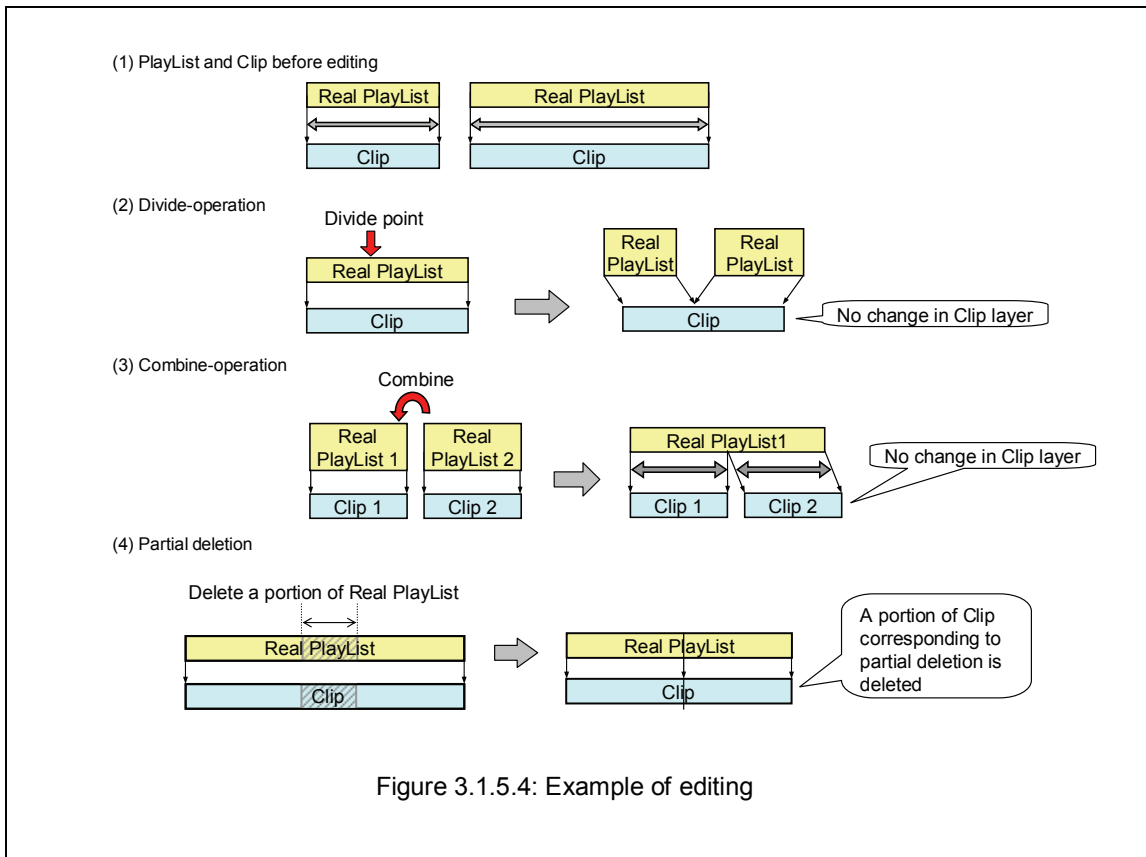

There is also the option of creating a new PlayList without altering an existing PlayList. Under the BD-RE Application Format, this is referred to as creating a virtual PlayList (Fig. 3.1.5.5).

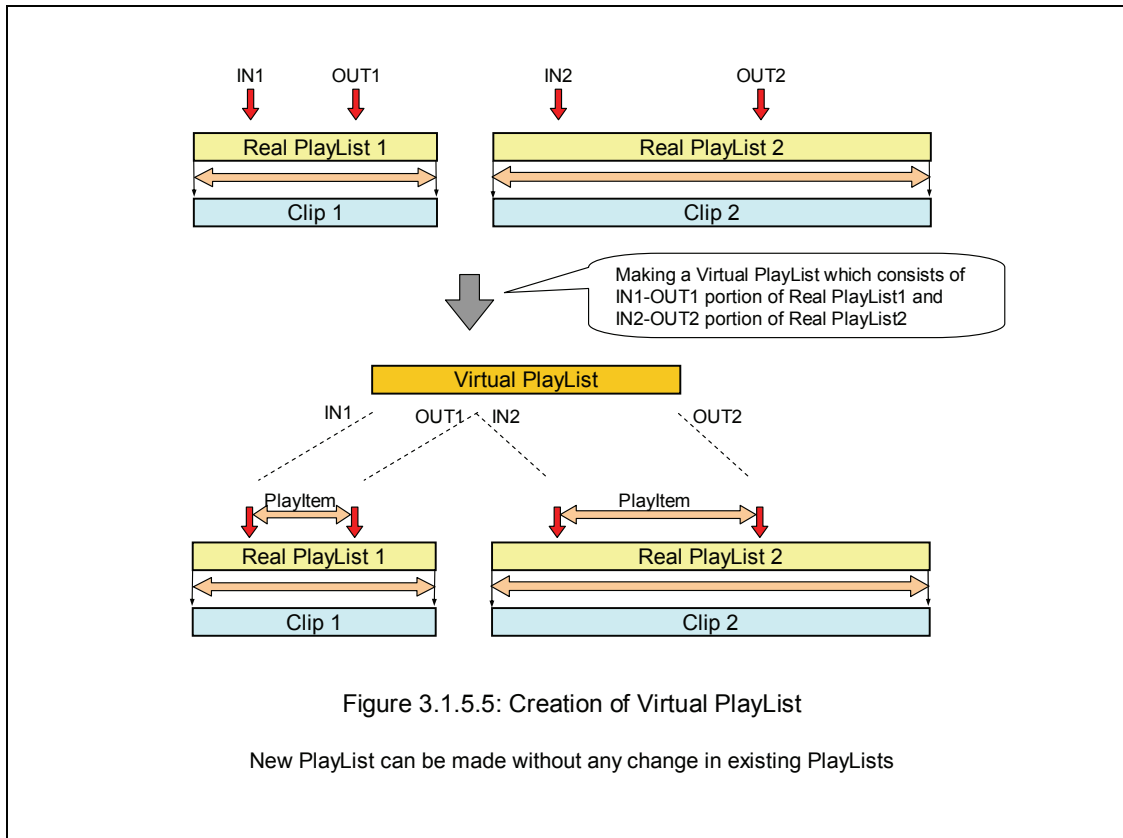

The virtual Playlist is a sequence of play-items that reference parts of other PlayLists; bridge sequences, described later, are used to achieve seamless playback even with non-destructive editing.

The BD-RE Application Format provides many other functions to improve ease-of-operation, such as thumbnails, marks, write protection, and playback-lock of individual discs using passwords.

Thumbnails are small still images and represent directory and Playlist contents in a visual manner. Under the BD-RE Application Format, thumbnails can be set to represent the entire recorded contents under the BDAV directory and also individual PlayLists.

A mark is the generic term for an index point that the user sets on the playback timeline to enhance ease-of-operation. Standard marks provided are bookmarks used for locating specific scenes, skip marks for skipping certain intervals during playback and resume marks for resuming playback from the scene where playback was previously stopped. Manufacturers can also add their own mark functions.

Fig. 3.1.5.6 shows the directory/file structure of the BD-RE Application Format where AV streams and databases are stored.

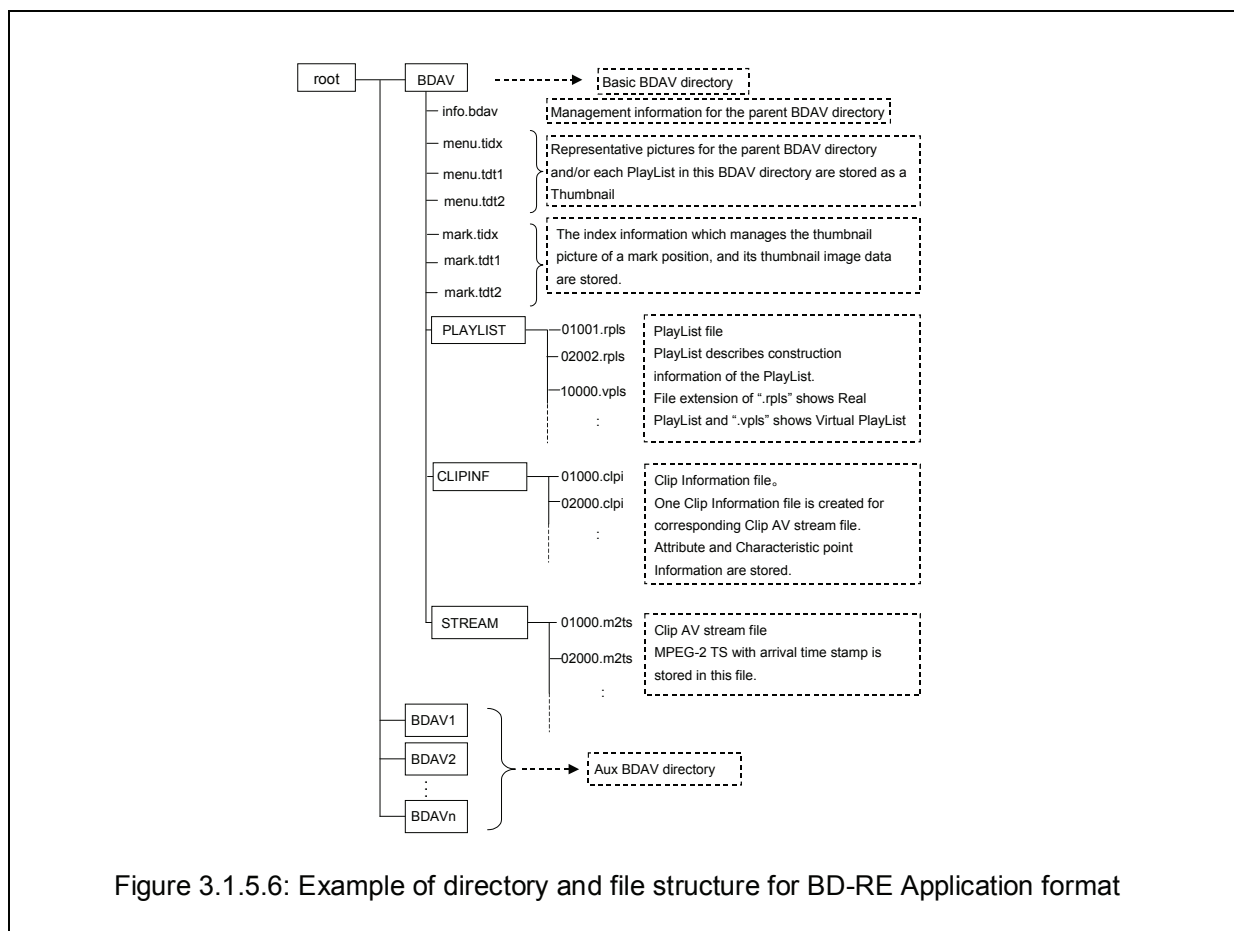

Figure 3.1.5.6: Example of directory and file structure for BD-RE Application format

6. Editing

6.1. Seamless Connection Editing

It is very important for a recording system to have easy-to-use editing functions that enable users to save wanted sections and cut out unwanted scenes from recorded contents (titles). The BD-RE Application Format realizes such editing functions through the virtual PlayList. For instance, by using the virtual PlayList, the user can select highlight scenes from different titles recorded on disc to create (edit) a new title of highlight scenes and organize/save the new title on disc (Fig. 3.1.5.1, Fig. 3.1.5.5).

As previously described, the BD-RE Application Format adopts MPEG2 and DV formats as its video recording format (recording codec). When MPEG2 is used for recording, each frame image of the content is coded into either of three types—I-picture, P-picture, or B-picture—and compressed and recorded. To give a brief description of the characteristics of the three compressed image types: I-picture is an image that is coded using only its own data information (intraframe coded picture), P-picture is an image that is coded based on a prediction of the preceding I-picture or P-picture (interframe forward-direction predictive coded picture) and B-picture is an image that is coded by processing the I-picture and P-picture first and then being inserted in between (bi-directional predictive coded picture). If, as shown in the figure, two scenes are selected from different titles (that is, separate contents that were recorded at different times) and connected or two scenes separated in time are selected from the same single recording and connected to create a new title, simply gathering the Clip AV streams and decoding the streams in succession will cause a break in the MPEG2 compression

pattern at the connection point (editing point) and, as a result, image frames will not be displayed contiguously. In other words, to display images contiguously even across the point where edited scenes are connected, the data needs to be restructured. The BD-RE Application Format specifies a structure (mechanism) called a bridge sequence to secure physical contiguity and ensure contiguous playback across the editing point. Bridge sequences are managed by the virtual Playlist which is a logical mechanism. A brief description is provided below of the concept of the bridge sequence based on Fig. 3.1.6.1.1.

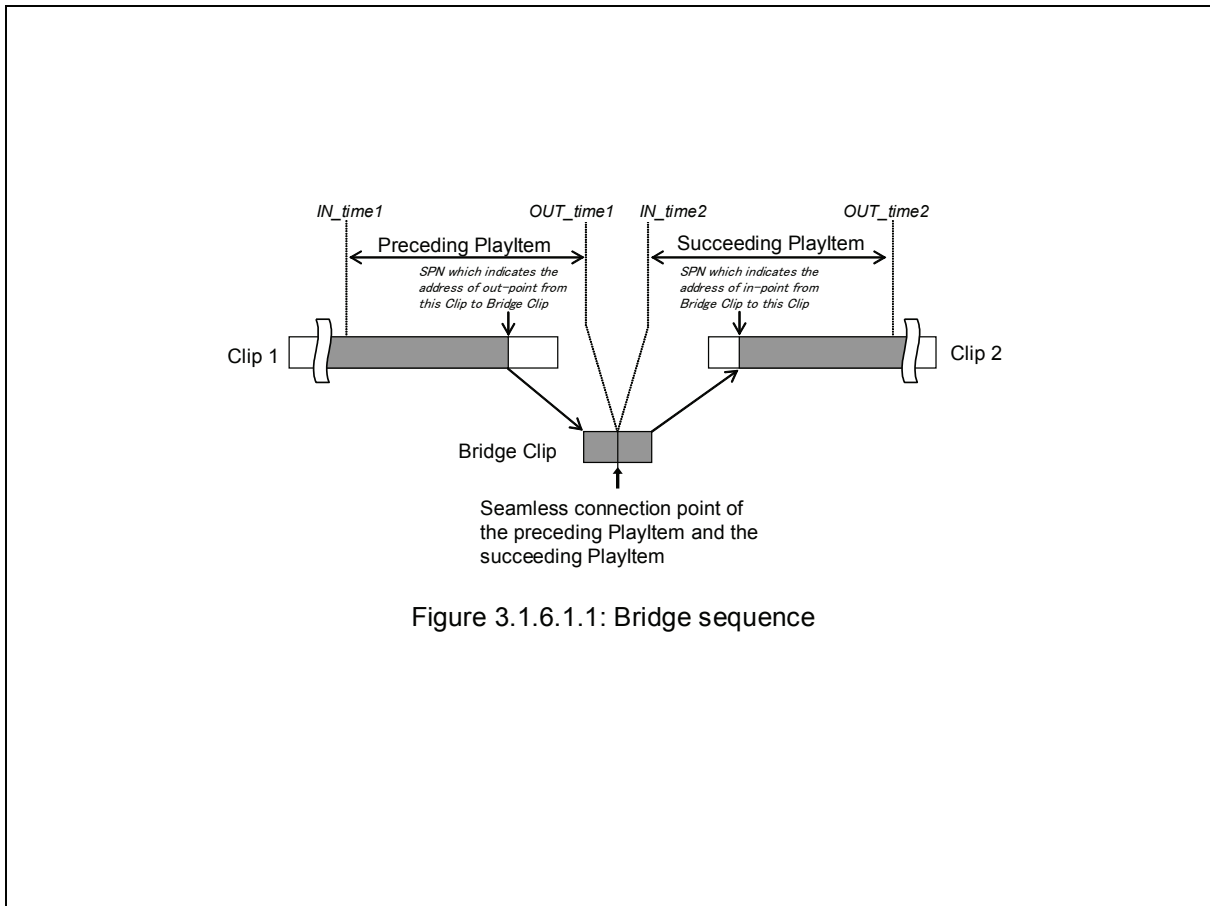

Figure 3.1.6.1.1: Bridge sequence

The bridge sequence reconstructs only the required parts as shown in Fig. 3.1.6.1.2 and is designed to keep data processing of editing points by the recorder to a minimum.

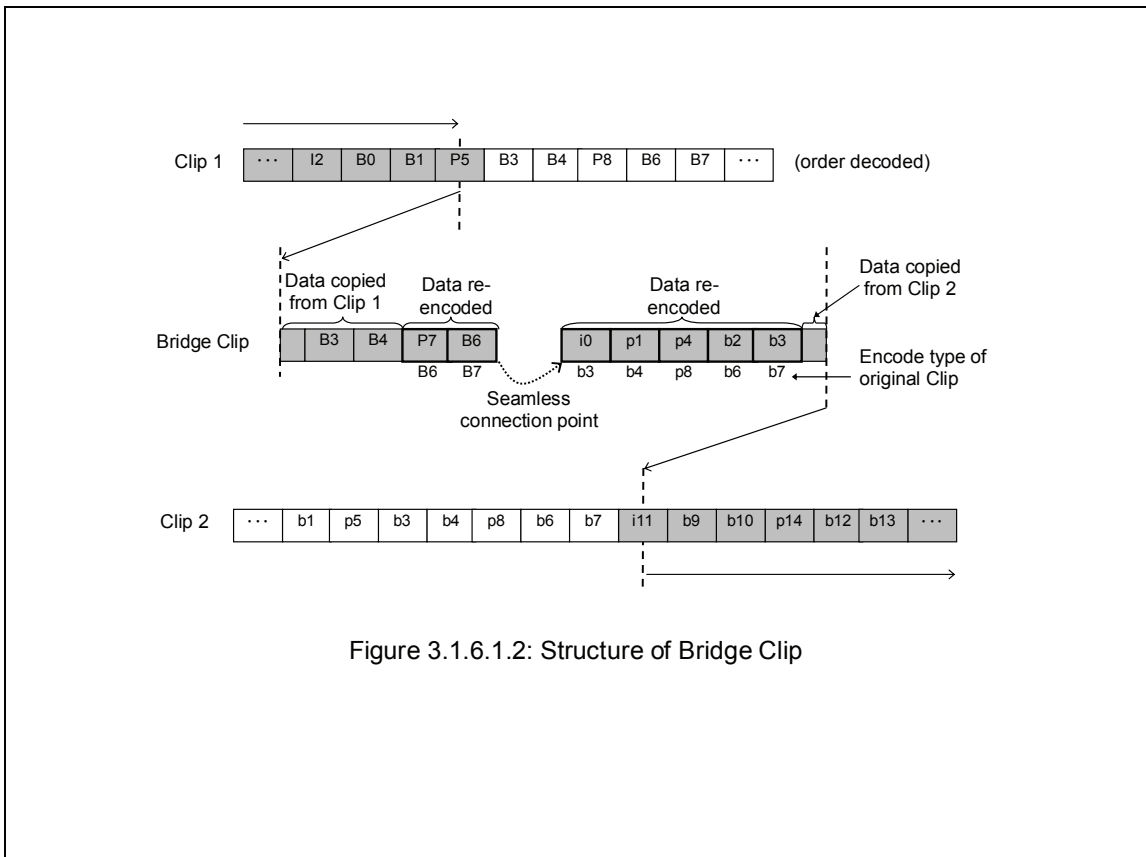
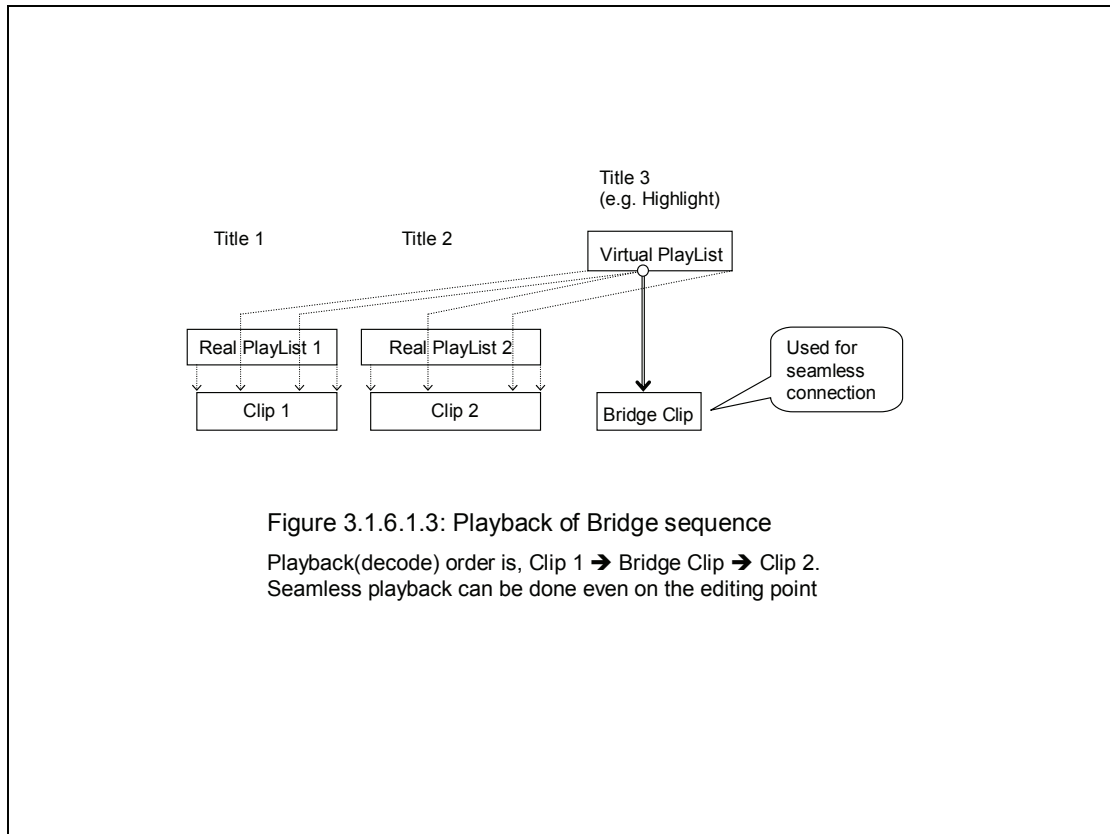

Figure 3.1.6.1.2: Structure of Bridge Clip

During playback, data is decoded in order of Clip 1→Bridge Clip→Clip 2 as shown in Fig. 3.1.6.1.3 to ensure contiguous playback across the editing point.



6.2. Audio Dubbing

In general, when recording contents under the BD-RE Application Format, a set of video and audio data is multiplexed in the transport stream and is recorded as a single Clip. (This transport stream is called the main-path.) For instance, this mechanism is used for time-shift recording of broadcast programs.

An important editing function that enhances the recording system is audio dubbing, which allows the user to easily add other audio data to content after it is recorded. The BD-RE Application Format realizes an audio dubbing function by providing a mechanism called the sub-path. The sub-path is a structure that enables the user to select a separate stream during playback of a Clip on the main-path and play back the stream simultaneously with data on the main-path or by itself. For instance, this functionality can be used with content on which audio dubbing was performed to play back the audio data on the main-path and the audio data of a separate Clip on the sub-path at the same time or singly. Fig. 3.1.6.2.1 shows the relation between the main-path and the sub-path. The playback function of dubbed audio is optional.

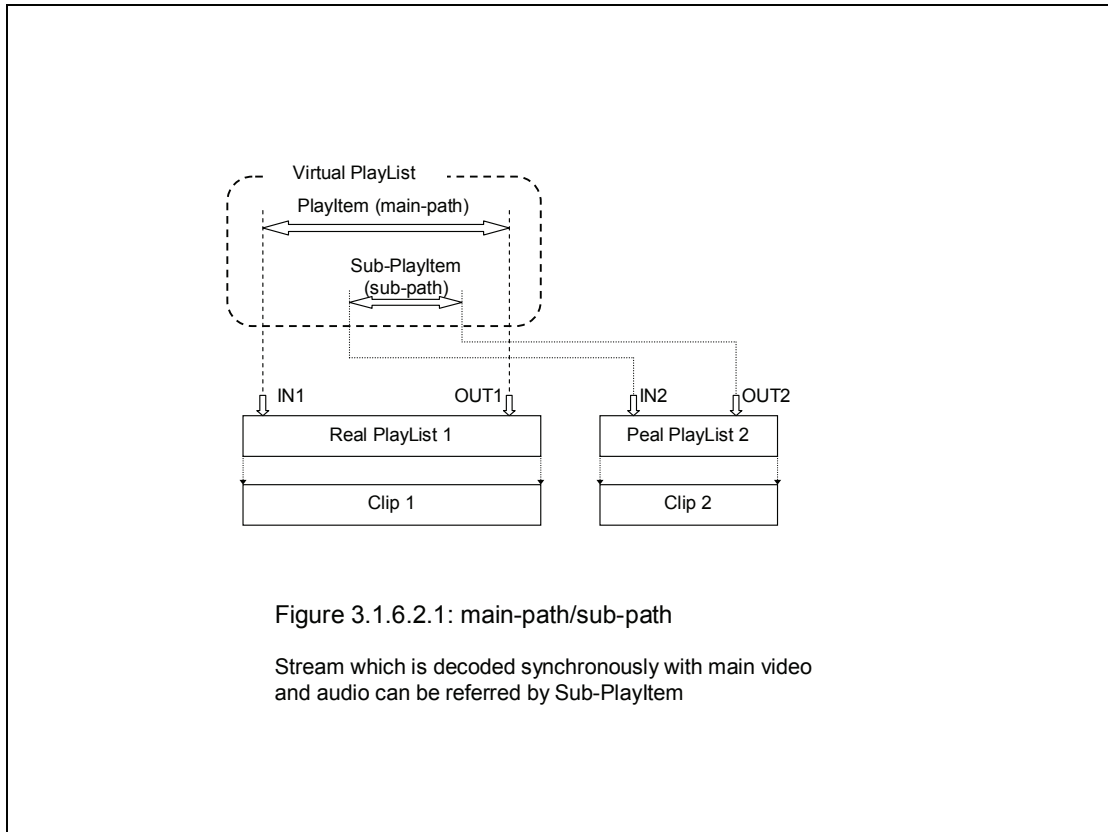

As shown in the figure, a sub-play-item is logically added to the play-item in the virtual Playlist to associate a separate Clip (sub-path) to the play-item on the main-path. The playback start time of the sub-play-item can be associated with the playback time (pts) of the play-item on the main-path. The recorder determines differences (such as the PCR value) in the timelines of the Clips on the main-path and the sub-path during playback and commences decoding.