

ARTIST ROSTER

GUITARS

Carl A. Tidemann
Keith Aazami
Tosin Abasi
Ae Aekachai Krai-arnon
Edouard Algailon
Richie Allan
Simon Andersson
Cory Arford
Yann Armellino
Chris Arp
Ond Arzapong Boonsermsup
Matt Aub
Paul Baayens
Daniel Bage
Bago
Rob Balducci
Ball
Terry Balsamo
Way Barrier
Billy the Bat
Honza Kirk Behunek
Steve Bello
Ricky Belloni
Justin Bender
Beng Beng
Jackson Benige
George Benson
Sammy Black
Alex Bois
Stijn Borgers
Jake Bowen
Alec Brentini
Chris Broderick
Geoff Brouillette
Steve Brown
Norman Brown
JB Brubaker
Tobias Buck
Adam Burman
Thomas "BUSCHY" Buschhausen
Gizz Butt
Rudi Buttas
Martin Butus
Chris Camozzi
Noah Carpenter
Dan Carter
Frank Caruso
AJ Castillo
Gianna Nannini, Solo Artist
Dino Cazares
Cesareo
Curtis Chambers
Andy Chandler
Sergo Chantury
Sebastien Chaput
Pascal Cheseaux
Josh Childers
Audley Chisholm
Choko
Alex Colin-Tocpaine
Claudio Cordero
Chad Crawford
Rob Daniels
Biom Dammy
Scott Danough
James Davies
Jim Davies
Benjamin Davis
Juan De Ferrari
L'Edo Leon
Deehellix
Isaac Delahaye
Sean Delander
Koen Delanghe
Douglas Doppel
Simona Dow
Fletcher Dragge
Kenneth Iain Duncan
Torben Enevoldsen
Niclas Engelin
Martyn Evans
Ryan Felton
Rui Fingers
Jon Finn
Georges Floride
Max Frunik
Justin Furstenfeld
Robbie Furze
Fuzz
Per Gade
Fabien Galland
Adriel Garcia
Pablo Garcia
Roland Gebhardt
Wes Geer
Rocky George
Andreas Gehhard
Susan Gerl
Paul Gilbert
John Paul Glover
Peter Goemaere
Matt Good
Marc Götz
Cristi Gram
Gravy
Calin Grigoriu
Karl Groom
Ryan Gudmunds
Noam Guedalia
Brandon Hackenson
Trent Hafdah
Mårten Hagström
Joel Haines
Paul Hanson
AJ Harvey
Mats Haugen
Simon Hawemann
Kasper Heikkinen
Ryan Helm
Oli Herbert
Dragomir Herendić Dragianni
Tony Hermando
Gabriel Hidalgo
Nick Hira
Hiro
Pontus Hjelm
Sander Hoek
Nitzan Hoffmann
Wojciech Hoffmann
Dexter Holland
Steve Holt
Trond "Teeny" Holter
Bernhard Horn
Luke Hoskin
Bill Hudson
Scott Hull
Ihsahn
Nightmare Industries

Andy Jackson
Brandon Jacobs
Mark Jansen
Jonas Jarsby
Peung Jatutapong Rumaklom
Bane Jelc
Star Academy
The Heavy Metal Nijas
Avatar
Camifex
Bad Acid Trip
Animals As Leaders
Ae Wizard
The Heavy Metal Nijas
Avatar
Camifex
Pyopus, Hank Williams, III
Street Funk Rollers
Timelord
Hall of Bullets
Shadows Fall
Mufin Within
Netal
Bangkaew
Evanescence
Destroy Destroy Destroy
Rity in a Casket
Krona Kirk Behunek
Steve Bello Band
Il Mito New Trolls
Into Eternity
Pas
(HED) p.e.
LOVEFX
Periphery
Poison My Blood
Periphery
Alec Brentini Band
Megadeth
Sleeping Giant
The Souless
August Burns Red
Nera
Spiritus
Ryuan Leitru
Gary Lenaire
Brian Leppke
Mike Lerner
Eyal Levi
Eugeniy Levin
Herman Li
Christian Lidsba
Holger Lieberenz
Jani Lillmanen
Chen-Yi Lin
Petri Lindroos
Manu Livertout
Juan Pablo Lobos
Legan
Loki
Alejandro Londoño
Juan Carlos Martin Lopez
Justin Lowe
Flemming Lund
Antoine Lusier
Tony MacAlpine
Mark MacDonald
Andrea Maddalone
Jari Mäenpää
Benjamin Malin
Christofer Malmström
Patrick Mamelí
David Manley
Teemu Mäntysaari
Khan Marue
Gary Markowski
Cazz Marlow
Andy Martin
Orazio Martino
Andreas Mäser
James Mclroy
Patrick Meadows
Sander van der Meer
Demian Mejicano
Champ Tanat Metanayon
Pat Metheny
Krzysztof Mielak
Mark Mitchell
Larry Mitchell
Atsushi Miyamoto
Alexander Mogilevsky
Liliasyter
Oskar Montelius
Munky
Christian Münzner
Yasushi Muratori
Stephen Murphy
Kamal Musallam
Marcel Neumann
Joseph Nicholson
Johan Niemann
Kristian Niemann
Per Nilsson
Taro Noda
Noodles
Daniel Oberländer
Marc Okubo
Pekka Oikarinen
Magnus Olsson
Ben Orum
All Shall Perish
Solo Artist
Jack Owen
Marek Pajak
David Patiau
Rob Patterson
Pat Pattison
Greely Estates
After the Burial
Meshuggah
Independent
Last Chance To Reason
Circus Maximus
War From A Harlots Mouth
Amberian Dawn, Guardians of Mankind
Demon Hunter
All That Remains
Saratoga
Gabriel Hidalgo Band, Six Magics
At Lay Dying
Head Phones President
Dead by April
Independent
Drive Like Maria
Turbo
The Offspring
36 Crazyfists
Wig Wam
Caljejon
Protest the Hero
Witten in Blood, Circle II Circle
Pig Destroyer
Ihsahn, Emperor
Deathstars

Terrible Things
Mufin Within
Epica, MaYaN
Avatar
Armchair
MALU
Magnitude 9
Session
The Faceless
Bonded By Blood
Spiritus
Damn of Ashes
Eye of the Enemy
ONMYO-ZA
Samsas Traum
Nraera
SERAPHIM
Emmure
Butch
Fields of the Nephilim
Kin'y
Drawn
Course of Nature
Nevio
Diecast
The Black Dahlia Murder
Evanescence
Diecast
Soulive
Hateform, Mors Principium Est
Candita, A Family Plot
Delta
Bonded By Blood
For Today
Soulive
Tomy Laisto
John Lamacchia
Lanyall
Igor Lapuhin
Jimmy Lardner-Brown
Terry Lauderdale
Parker Lauzon
Benjamin Lechuga
Alex Lee
Ryan Leitru
Gary Lenaire
Brian Leppke
Mike Lerner
Eyal Levi
Eugeniy Levin
Herman Li
Christian Lidsba
Holger Lieberenz
Jani Lillmanen
Chen-Yi Lin
Petri Lindroos
Manu Livertout
Juan Pablo Lobos
Legan
Loki
Alejandro Londoño
Juan Carlos Martin Lopez
Justin Lowe
Flemming Lund
Antoine Lusier
Tony MacAlpine
Mark MacDonald
Andrea Maddalone
Jari Mäenpää
Benjamin Malin
Christofer Malmström
Patrick Mamelí
David Manley
Teemu Mäntysaari
Khan Marue
Gary Markowski
Cazz Marlow
Andy Martin
Orazio Martino
Andreas Mäser
James Mclroy
Patrick Meadows
Sander van der Meer
Demian Mejicano
Champ Tanat Metanayon
Pat Metheny
Krzysztof Mielak
Mark Mitchell
Larry Mitchell
Atsushi Miyamoto
Alexander Mogilevsky
Liliasyter
Oskar Montelius
Munky
Christian Münzner
Yasushi Muratori
Stephen Murphy
Kamal Musallam
Marcel Neumann
Joseph Nicholson
Johan Niemann
Kristian Niemann
Per Nilsson
Taro Noda
Noodles
Daniel Oberländer
Marc Okubo
Pekka Oikarinen
Magnus Olsson
Ben Orum
All Shall Perish
Solo Artist
Jack Owen
Marek Pajak
David Patiau
Rob Patterson
Pat Pattison
Greely Estates
After the Burial
Meshuggah
Independent
Last Chance To Reason
Circus Maximus
War From A Harlots Mouth
Amberian Dawn, Guardians of Mankind
Demon Hunter
All That Remains
Saratoga
Gabriel Hidalgo Band, Six Magics
At Lay Dying
Head Phones President
Dead by April
Independent
Drive Like Maria
Turbo
The Offspring
36 Crazyfists
Wig Wam
Caljejon
Protest the Hero
Witten in Blood, Circle II Circle
Pig Destroyer
Ihsahn, Emperor
Deathstars

Animals as Leaders
For Today
Timelord
ReYamp
RIME
Deja Voodoo Spells
Metalasia
Roch Violine, Wazimba
Yannick Robert
Matt Roberts
Chad Robles
Robby Rockbag
Alexis Rodriguez
Omar Rodriguez-Lopez
Gianni Rojatti
Igor Romanov
Patrick Rondat
Tim Roth
Carlos Rufo
Jack Rufo
Noves Luna, Neo Colours, Kitchie Nadal Band
Gert Rymen
Vladimir Khoryjii
Simoen Salvatore
Eric Sands
Joe Saltriani
Henri Sattler
Denis Schmidt
Oliver Schmidt
Simson Koch
Kirk Kolaits
John Scofield
Jake Scott
Jeremiah Scott
Arthur Seay
Dominyk Sebastian
Eran Seegal
Roni Seppänen
King Shah
Justin Shekoski
Devin Shidaker
David Shoaf
Shore
Christoph Siemons
Franky Shombing
Dwight Sills
Alejandro Silva
Roger Sunnesson
Terji Skibenas
Michael Soiminen
Ralf Sommerfeld
Sony
Ken Sorceror
Waldemar Sorychta
Felipe Souza
Chris Stalder
Matt Steane
Legan
Barry Stock
Nita Strauss
Vince Stropki
Jason Suecof
Muhammad Sul'cmz
Antoine Lusier
Marcus Sunnesson
Ken Susi
Tommy Svela
Jon Symons
Brian Tabb
Daniel Telle Project
Bobby Thompson
Mick Thomson
Fredrik Thordendal
Olaf Thorsen
Frank Tjink
Andy Timmons
Tobias
Markus Toivonen
Tora
Ulmut, Tere
Alex Turner
Gisle Torvik
Sam Totman
Rares Totu
Josh Travis
Koji Tsunoto
Olli Tuikainen
Sebastien Tuvi
Dave Uhrich
U-Nam
Monte Money
Ludovico Vagnone
Steve Vai
Javi Valero
Sander van der Meer
Chema Vazquez
Elias Vilijanen
Harj Virdee
Angel Vivaldi
Scott Von Heldt
Tommy Vucur
Everton Waldman
Pop Waravi
Rich Ward
Tom G. Warrior
Yu Watanabe
Bob West
Brian "Head" Welch
Jussi Wickström
Nathan Wood
Stefano "Sebo" Xotta
Lucas Yaksic
Lucas Yaksic Band
ex. derZbeZ, PUGS
Solo Artist
My New Zoo
Hämatom
Pestilence
Independent
O'Funk'illo
Cypher
Cypher
Sonata Arctica
Panic Cell
Head
Vanishing Point
RT
Rancorous
Fozzy, Stuck Mojo
Triptykon
DAZZLE VISION
RatDog, The Dead
Turisas
Panic Cell
UTEZ, Strings 24
Lucas Yaksic Band
ex. derZbeZ, PUGS
Solo Artist
My New Zoo
Hämatom
Pestilence
Independent
O'Funk'illo
Cypher
Sonata Arctica
Panic Cell
Head
Vanishing Point
RT
Rancorous
Fozzy, Stuck Mojo
Triptykon
DAZZLE VISION
RatDog, The Dead
Turisas
Panic Cell
UTEZ, Strings 24
Lucas Yaksic Band
ex. derZbeZ, PUGS
Solo Artist
My New Zoo
Hämatom
Pestilence
Independent
O'Funk'illo
Cypher
Sonata Arctica
Panic Cell
Head
Vanishing Point
RT
Rancorous
Fozzy, Stuck Mojo
Triptykon
DAZZLE VISION
RatDog, The Dead
Turisas
Panic Cell
UTEZ, Strings 24
Lucas Yaksic Band
ex. derZbeZ, PUGS
Solo Artist
My New Zoo
Hämatom
Pestilence
Independent
O'Funk'illo
Cypher
Sonata Arctica
Panic Cell
Head
Vanishing Point
RT
Rancorous
Fozzy, Stuck Mojo
Triptykon
DAZZLE VISION
RatDog, The Dead
Turisas
Panic Cell
UTEZ, Strings 24
Lucas Yaksic Band
ex. derZbeZ, PUGS
Solo Artist
My New Zoo
Hämatom
Pestilence
Independent
O'Funk'illo
Cypher
Sonata Arctica
Panic Cell
Head
Vanishing Point
RT
Rancorous
Fozzy, Stuck Mojo
Triptykon
DAZZLE VISION
RatDog, The Dead
Turisas
Panic Cell
UTEZ, Strings 24
Lucas Yaksic Band
ex. derZbeZ, PUGS
Solo Artist
My New Zoo
Hämatom
Pestilence
Independent
O'Funk'illo
Cypher
Sonata Arctica
Panic Cell
Head
Vanishing Point
RT
Rancorous
Fozzy, Stuck Mojo
Triptykon
DAZZLE VISION
RatDog, The Dead
Turisas
Panic Cell
UTEZ, Strings 24
Lucas Yaksic Band
ex. derZbeZ, PUGS
Solo Artist
My New Zoo
Hämatom
Pestilence
Independent
O'Funk'illo
Cypher
Sonata Arctica
Panic Cell
Head
Vanishing Point
RT
Rancorous
Fozzy, Stuck Mojo
Triptykon
DAZZLE VISION
RatDog, The Dead
Turisas
Panic Cell
UTEZ, Strings 24
Lucas Yaksic Band
ex. derZbeZ, PUGS
Solo Artist
My New Zoo
Hämatom
Pestilence
Independent
O'Funk'illo
Cypher
Sonata Arctica
Panic Cell
Head
Vanishing Point
RT
Rancorous
Fozzy, Stuck Mojo
Triptykon
DAZZLE VISION
RatDog, The Dead
Turisas
Panic Cell
UTEZ, Strings 24
Lucas Yaksic Band
ex. derZbeZ, PUGS
Solo Artist
My New Zoo
Hämatom
Pestilence
Independent
O'Funk'illo
Cypher
Sonata Arctica
Panic Cell
Head
Vanishing Point
RT
Rancorous
Fozzy, Stuck Mojo
Triptykon
DAZZLE VISION
RatDog, The Dead
Turisas
Panic Cell
UTEZ, Strings 24
Lucas Yaksic Band
ex. derZbeZ, PUGS
Solo Artist
My New Zoo
Hämatom
Pestilence
Independent
O'Funk'illo
Cypher
Sonata Arctica
Panic Cell
Head
Vanishing Point
RT
Rancorous
Fozzy, Stuck Mojo
Triptykon
DAZZLE VISION
RatDog, The Dead
Turisas
Panic Cell
UTEZ, Strings 24
Lucas Yaksic Band
ex. derZbeZ, PUGS
Solo Artist
My New Zoo
Hämatom
Pestilence
Independent
O'Funk'illo
Cypher
Sonata Arctica
Panic Cell
Head
Vanishing Point
RT
Rancorous
Fozzy, Stuck Mojo
Triptykon
DAZZLE VISION
RatDog, The Dead
Turisas
Panic Cell
UTEZ, Strings 24
Lucas Yaksic Band
ex. derZbeZ, PUGS
Solo Artist
My New Zoo
Hämatom
Pestilence
Independent
O'Funk'illo
Cypher
Sonata Arctica
Panic Cell
Head
Vanishing Point
RT
Rancorous
Fozzy, Stuck Mojo
Triptykon
DAZZLE VISION
RatDog, The Dead
Turisas
Panic Cell
UTEZ, Strings 24
Lucas Yaksic Band
ex. derZbeZ, PUGS
Solo Artist
My New Zoo
Hämatom
Pestilence
Independent
O'Funk'illo
Cypher
Sonata Arctica
Panic Cell
Head
Vanishing Point
RT
Rancorous
Fozzy, Stuck Mojo
Triptykon
DAZZLE VISION
RatDog, The Dead
Turisas
Panic Cell
UTEZ, Strings 24
Lucas Yaksic Band
ex. derZbeZ, PUGS
Solo Artist
My New Zoo
Hämatom
Pestilence
Independent
O'Funk'illo
Cypher
Sonata Arctica
Panic Cell
Head
Vanishing Point
RT
Rancorous
Fozzy, Stuck Mojo
Triptykon
DAZZLE VISION
RatDog, The Dead
Turisas
Panic Cell
UTEZ, Strings 24
Lucas Yaksic Band
ex. derZbeZ, PUGS
Solo Artist
My New Zoo
Hämatom
Pestilence
Independent
O'Funk'illo
Cypher
Sonata Arctica
Panic Cell
Head
Vanishing Point
RT
Rancorous
Fozzy, Stuck Mojo
Triptykon
DAZZLE VISION
RatDog, The Dead
Turisas
Panic Cell
UTEZ, Strings 24
Lucas Yaksic Band
ex. derZbeZ, PUGS
Solo Artist
My New Zoo
Hämatom
Pestilence
Independent
O'Funk'illo
Cypher
Sonata Arctica
Panic Cell
Head
Vanishing Point
RT
Rancorous
Fozzy, Stuck Mojo
Triptykon
DAZZLE VISION
RatDog, The Dead
Turisas
Panic Cell
UTEZ, Strings 24
Lucas Yaksic Band
ex. derZbeZ, PUGS
Solo Artist
My New Zoo
Hämatom
Pestilence
Independent
O'Funk'illo
Cypher
Sonata Arctica
Panic Cell
Head
Vanishing Point
RT
Rancorous
Fozzy, Stuck Mojo
Triptykon
DAZZLE VISION
RatDog, The Dead
Turisas
Panic Cell
UTEZ, Strings 24
Lucas Yaksic Band
ex. derZbeZ, PUGS
Solo Artist
My New Zoo
Hämatom
Pestilence
Independent
O'Funk'illo
Cypher
Sonata Arctica
Panic Cell
Head
Vanishing Point
RT
Rancorous
Fozzy, Stuck Mojo
Triptykon
DAZZLE VISION
RatDog, The Dead
Turisas
Panic Cell
UTEZ, Strings 24
Lucas Yaksic Band
ex. derZbeZ, PUGS
Solo Artist
My New Zoo
Hämatom
Pestilence
Independent
O'Funk'illo
Cypher
Sonata Arctica
Panic Cell
Head
Vanishing Point
RT
Rancorous
Fozzy, Stuck Mojo
Triptykon
DAZZLE VISION
RatDog, The Dead
Turisas
Panic Cell
UTEZ, Strings 24
Lucas Yaksic Band
ex. derZbeZ, PUGS
Solo Artist
My New Zoo
Hämatom
Pestilence
Independent
O'Funk'illo
Cypher
Sonata Arctica
Panic Cell
Head
Vanishing Point
RT
Rancorous
Fozzy, Stuck Mojo
Triptykon
DAZZLE VISION
RatDog, The Dead
Turisas
Panic Cell
UTEZ, Strings 24
Lucas Yaksic Band
ex. derZbeZ, PUGS
Solo Artist
My New Zoo
Hämatom
Pestilence
Independent
O'Funk'illo
Cypher
Sonata Arctica
Panic Cell
Head
Vanishing Point
RT
Rancorous
Fozzy, Stuck Mojo
Triptykon
DAZZLE VISION
RatDog, The Dead
Turisas
Panic Cell
UTEZ, Strings 24
Lucas Yaksic Band
ex. derZbeZ, PUGS
Solo Artist
My New Zoo
Hämatom
Pestilence
Independent
O'Funk'illo
Cypher
Sonata Arctica
Panic Cell
Head
Vanishing Point
RT
Rancorous
Fozzy, Stuck Mojo
Triptykon
DAZZLE VISION
RatDog, The Dead
Turisas
Panic Cell
UTEZ, Strings 24
Lucas Yaksic Band
ex. derZbeZ, PUGS
Solo Artist
My New Zoo
Hämatom
Pestilence
Independent
O'Funk'illo
Cypher
Sonata Arctica
Panic Cell
Head
Vanishing Point
RT
Rancorous
Fozzy, Stuck Mojo
Triptykon
DAZZLE VISION
RatDog, The Dead
Turisas
Panic Cell
UTEZ, Strings 24
Lucas Yaksic Band
ex. derZbeZ, PUGS
Solo Artist
My New Zoo
Hämatom
Pestilence
Independent
O'Funk'illo
Cypher
Sonata Arctica
Panic Cell
Head
Vanishing Point
RT
Rancorous
Fozzy, Stuck Mojo
Triptykon
DAZZLE VISION
RatDog, The Dead
Turisas
Panic Cell
UTEZ, Strings 24
Lucas Yaksic Band
ex. derZbeZ, PUGS
Solo Artist
My New Zoo
Hämatom
Pestilence
Independent
O'Funk'illo
Cypher
Sonata Arctica
Panic Cell
Head
Vanishing Point
RT
Rancorous
Fozzy, Stuck Mojo
Triptykon
DAZZLE VISION
RatDog, The Dead
Turisas
Panic Cell
UTEZ, Strings 24
Lucas Yaksic Band
ex. derZbeZ, PUGS
Solo Artist
My New Zoo
Hämatom
Pestilence
Independent
O'Funk'illo
Cypher
Sonata Arctica
Panic Cell
Head
Vanishing Point
RT
Rancorous
Fozzy, Stuck Mojo
Triptykon
DAZZLE VISION
RatDog, The Dead
Turisas
Panic Cell
UTEZ, Strings 24
Lucas Yaksic Band
ex. derZbeZ, PUGS
Solo Artist
My New Zoo
Hämatom
Pestilence
Independent
O'Funk'illo
Cypher
Sonata Arctica
Panic Cell
Head
Vanishing Point
RT
Rancorous
Fozzy, Stuck Mojo
Triptykon
DAZZLE VISION
RatDog, The Dead
Turisas
Panic Cell
UTEZ, Strings 24
Lucas Yaksic Band
ex. derZbeZ, PUGS
Solo Artist
My New Zoo
Hämatom
Pestilence
Independent
O'Funk'illo
Cypher
Sonata Arctica
Panic Cell
Head
Vanishing Point
RT
Rancorous
Fozzy, Stuck Mojo
Triptykon
DAZZLE VISION
RatDog, The Dead
Turisas
Panic Cell
UTEZ, Strings 24
Lucas Yaksic Band
ex. derZbeZ, PUGS
Solo Artist
My New Zoo
Hämatom
Pestilence
Independent
O'Funk'illo
Cypher
Sonata Arctica
Panic Cell
Head
Vanishing Point
RT
Rancorous
Fozzy, Stuck Mojo
Triptykon
DAZZLE VISION
RatDog, The Dead
Turisas
Panic Cell
UTEZ, Strings 24
Lucas Yaksic Band
ex. derZbeZ, PUGS
Solo Artist
My New Zoo
Hämatom
Pestilence
Independent
O'Funk'illo
Cypher
Sonata Arctica
Panic Cell
Head
Vanishing Point
RT
Rancorous
Fozzy, Stuck Mojo
Triptykon
DAZZLE VISION
RatDog, The Dead
Turisas
Panic Cell
UTEZ, Strings 24
Lucas Yaksic Band
ex. derZbeZ, PUGS
Solo Artist
My New Zoo
Hämatom
Pestilence
Independent
O'Funk'illo
Cypher
Sonata Arctica
Panic Cell
Head
Vanishing Point
RT
Rancorous
Fozzy, Stuck Mojo
Triptykon
DAZZLE VISION
RatDog, The Dead
Turisas
Panic Cell
UTEZ, Strings 24
Lucas Yaksic Band
ex. derZbeZ, PUGS
Solo Artist
My New Zoo
Hämatom
Pestilence
Independent
O'Funk'illo
Cypher
Sonata Arctica
Panic Cell
Head
Vanishing Point
RT
Rancorous
Fozzy, Stuck Mojo
Triptykon
DAZZLE VISION
RatDog, The Dead
Turisas
Panic Cell
UTEZ, Strings 24
Lucas Yaksic Band
ex. derZbeZ, PUGS
Solo Artist
My New Zoo
Hämatom
Pestilence
Independent
O'Funk'illo
Cypher
Sonata Arctica
Panic Cell
Head
Vanishing Point
RT
Rancorous
Fozzy, Stuck Mojo
Triptykon
DAZZLE VISION
RatDog, The Dead
Turisas
Panic Cell
UTEZ, Strings 24
Lucas Yaksic Band
ex. derZbeZ, PUGS
Solo Artist
My New Zoo
Hämatom
Pestilence
Independent
O'Funk'illo
Cypher
Sonata Arctica
Panic Cell
Head
Vanishing Point
RT
Rancorous
Fozzy, Stuck Mojo
Triptykon
DAZZLE VISION
RatDog, The Dead
Turisas
Panic Cell
UTEZ, Strings 24
Lucas Yaksic Band
ex. derZbeZ, PUGS
Solo Artist
My New Zoo
Hämatom
Pestilence
Independent
O'Funk'illo
Cypher
Sonata Arctica
Panic Cell
Head
Vanishing Point
RT
Rancorous
Fozzy, Stuck Mojo
Triptykon
DAZZLE VISION
RatDog, The Dead
Turisas
Panic Cell
UTEZ, Strings 24
Lucas Yaksic Band
ex. derZbeZ, PUGS
Solo Artist
My New Zoo
Hämatom
Pestilence
Independent
O'Funk'illo
Cypher
Sonata Arctica
Panic Cell
Head
Vanishing Point
RT
Rancorous
Fozzy, Stuck Mojo
Triptykon
DAZZLE VISION
RatDog, The Dead
Turisas
Panic Cell
UTEZ, Strings 24
Lucas Yaksic Band
ex. derZbeZ, PUGS
Solo Artist
My New Zoo
Hämatom
Pestilence
Independent
O'Funk'illo
Cypher
Sonata Arctica
Panic Cell
Head
Vanishing Point
RT
Rancorous
Fozzy, Stuck Mojo
Triptykon
DAZZLE VISION
RatDog, The Dead
Turisas
Panic Cell
UTEZ, Strings 24
Lucas Yaksic Band
ex. derZbeZ, PUGS
Solo Artist
My New Zoo
Hämatom
Pestilence
Independent
O'Funk'illo
Cypher
Sonata Arctica
Panic Cell
Head
Vanishing Point
RT
Rancorous
Fozzy, Stuck Mojo
Triptykon
DAZZLE VISION
RatDog, The Dead
Turisas
Panic Cell
UTEZ, Strings 24
Lucas Yaksic Band
ex. derZbeZ, PUGS
Solo Artist
My New Zoo
Hämatom
Pestilence
Independent
O'Funk'illo
Cypher
Sonata Arctica
Panic Cell
Head
Vanishing Point
RT
Rancorous
Fozzy, Stuck Mojo
Triptykon
DAZZLE VISION
RatDog, The Dead
Turisas
Panic Cell
UTEZ, Strings 24
Lucas Yaksic Band
ex. derZbeZ, PUGS
Solo Artist
My New Zoo
Hämatom
Pestilence
Independent
O'Funk'illo
Cypher
Sonata Arctica
Panic Cell
Head
Vanishing Point
RT
Rancorous
Fozzy, Stuck Mojo
Triptykon
DAZZLE VISION
RatDog, The Dead
Turisas
Panic Cell
UTEZ, Strings 24
Lucas Yaksic Band
ex. derZbeZ, PUGS
Solo Artist
My New Zoo
Hämatom
Pestilence
Independent
O'Funk'illo
Cypher
Sonata Arctica
Panic Cell
Head
Vanishing Point
RT
Rancorous
Fozzy, Stuck Mojo
Triptykon
DAZZLE VISION
RatDog, The Dead
Turisas
Panic Cell
UTEZ, Strings 24
Lucas Yaksic Band
ex. derZbeZ, PUGS
Solo Artist
My New Zoo
Hämatom
Pestilence
Independent
O'Funk'illo
Cypher
Sonata Arctica
Panic Cell
Head
Vanishing Point
RT
Rancorous
Fozzy, Stuck Mojo
Triptykon
DAZZLE VISION
RatDog, The Dead
Turisas
Panic Cell
UTEZ, Strings 24
Lucas Yaksic Band
ex. derZbeZ, PUGS
Solo Artist
My New Zoo
Hämatom
Pestilence
Independent
O'Funk'illo
Cypher
Sonata Arctica
Panic Cell
Head
Vanishing Point
RT
Rancorous
Fozzy, Stuck Mojo
Triptykon
DAZZLE VISION
RatDog, The Dead
Turisas
Panic Cell
UTEZ, Strings 24
Lucas Yaksic Band
ex. derZbeZ, PUGS
Solo Artist
My New Zoo
Hämatom
Pestilence
Independent
O'Funk'illo
Cypher
Sonata Arctica
Panic Cell
Head
Vanishing Point
RT
Rancorous
Fozzy, Stuck Mojo
Triptykon
DAZZLE VISION
RatDog, The Dead
Turisas
Panic Cell
UTEZ, Strings 24
Lucas Yaksic Band
ex. derZbeZ, PUGS
Solo Artist
My New Zoo
Hämatom
Pestilence
Independent
O'Funk'illo
Cypher
Sonata Arctica
Panic Cell
Head
Vanishing Point
RT
Rancorous
Fozzy, Stuck Mojo
Triptykon
DAZZLE VISION
RatDog, The Dead
Turisas
Panic Cell
UTEZ, Strings 24
Lucas Yaksic Band
ex. derZbeZ, PUGS
Solo Artist
My New Zoo
Hämatom
Pestilence
Independent
O'Funk'illo
Cypher
Sonata Arctica
Panic Cell
Head
Vanishing Point
RT
Rancorous
Fozzy, Stuck Mojo
Triptykon
DAZZLE VISION
RatDog, The Dead
Turisas
Panic Cell
UTEZ, Strings 24
Lucas Yaksic Band
ex. derZbeZ, PUGS
Solo Artist
My New Zoo
Hämatom
Pestilence
Independent
O'Funk'illo
Cypher
Sonata Arctica
Panic Cell
Head
Vanishing Point
RT
Rancorous
Fozzy, Stuck Mojo
Triptykon
DAZZLE VISION
RatDog, The Dead
Turisas
Panic Cell
UTEZ, Strings 24
Lucas Yaksic Band
ex. derZbeZ, PUGS
Solo Artist
My New Zoo
Hämatom
Pestilence
Independent
O'Funk'illo
Cypher
Sonata Arctica
Panic Cell
Head
Vanishing Point
RT
Rancorous
Fozzy, Stuck Mojo
Triptykon
DAZZLE VISION
RatDog, The Dead
Turisas
Panic Cell
UTEZ, Strings 24
Lucas Yaksic Band
ex. derZbeZ, PUGS
Solo Artist
My New Zoo
Hämatom
Pestilence
Independent
O'Funk'illo
Cypher
Sonata Arctica
Panic Cell
Head
Vanishing Point
RT
Rancorous
Fozzy, Stuck Mojo
Triptykon
DAZZLE VISION
RatDog, The Dead
Turisas
Panic Cell
UTEZ, Strings 24
Lucas Yaksic Band
ex. derZbeZ, PUGS
Solo Artist
My New Zoo
Hämatom
Pestilence
Independent
O'Funk'illo
Cypher
Sonata Arctica
Panic Cell
Head
Vanishing Point
RT
Rancorous
Fozzy, Stuck Mojo
Triptykon
DAZZLE VISION
RatDog, The Dead
Turisas
Panic Cell
UTEZ, Strings 24
Lucas Yaksic Band
ex. derZbeZ, PUGS
Solo Artist
My New Zoo
Hämatom
Pestilence
Independent
O'Funk'illo
Cypher
Sonata Arctica
Panic Cell
Head
Vanishing Point
RT
Rancorous
Fozzy, Stuck Mojo
Triptykon
DAZZLE VISION
RatDog, The Dead
Turisas
Panic Cell
UTEZ, Strings 24
Lucas Yaksic Band
ex. derZbeZ, PUGS
Solo Artist
My New Zoo
Hämatom
Pestilence
Independent
O'Funk'illo
Cypher
Sonata Arctica
Panic Cell
Head
Vanishing Point
RT
Rancorous
Fozzy, Stuck Mojo
Triptykon
DAZZLE VISION
RatDog, The Dead
Turisas
Panic Cell
UTEZ, Strings 24
Lucas Yaksic Band
ex. derZbeZ, PUGS
Solo Artist
My New Zoo
Hämatom
Pestilence
Independent
O'Funk'illo
Cypher
Sonata Arctica
Panic Cell
Head
Vanishing Point
RT
Rancorous
Fozzy, Stuck Mojo
Triptykon
DAZZLE VISION
RatDog, The Dead
Turisas
Panic Cell
UTEZ, Strings 24
Lucas Yaksic Band
ex. derZbeZ, PUGS
Solo Artist
My New Zoo
Hämatom
Pestilence
Independent
O'Funk'illo
Cypher
Sonata Arctica
Panic Cell
Head
Vanishing Point
RT
Rancorous
Fozzy, Stuck Mojo
Triptykon
DAZZLE VISION
RatDog, The Dead
Turisas
Panic Cell
UTEZ, Strings 24
Lucas Yaksic Band
ex. derZbeZ, PUGS
Solo Artist
My New Zoo
Hämatom
Pestilence
Independent
O'Funk'illo
Cypher
Sonata Arctica
Panic Cell
Head
Vanishing Point
RT
Rancorous
Fozzy, Stuck Mojo
Triptykon
DAZZLE VISION
RatDog, The Dead
Turisas
Panic Cell
UTEZ, Strings 24
Lucas Yaksic Band
ex. derZbeZ, PUGS
Solo Artist
My New Zoo
Hämatom
Pestilence
Independent
O'Funk'illo
Cypher
Sonata Arctica
Panic Cell
Head
Vanishing Point
RT
Rancorous
Fozzy, Stuck Mojo
Triptykon
DAZZLE VISION
RatDog, The Dead
Turisas
Panic Cell
UTEZ, Strings 24
Lucas Yaksic Band
ex. derZbeZ, PUGS
Solo Artist
My New Zoo
Hämatom
Pestilence
Independent
O'Funk'illo
Cypher
Sonata Arctica
Panic Cell
Head
Vanishing Point
RT
Rancorous
Fozzy, Stuck Mojo
Triptykon
DAZZLE VISION
RatDog, The Dead
Turisas
Panic Cell
UTEZ, Strings 24
Lucas Yaksic Band
ex. derZbeZ, PUGS
Solo Artist
My New Zoo
Hämatom
Pestilence
Independent
O'Funk'illo
Cypher
Sonata Arctica
Panic Cell
Head
Vanishing Point
RT
Rancorous
Fozzy, Stuck Mojo
Triptykon
DAZZLE VISION
RatDog, The Dead
Turisas
Panic Cell
UTEZ, Strings 24
Lucas Yaksic Band
ex. derZbeZ, PUGS
Solo Artist
My New Zoo
Hämatom
Pestilence
Independent
O'Funk'illo
Cypher
Sonata Arctica
Panic Cell
Head
Vanishing Point
RT
Rancorous
Fozzy, Stuck Mojo
Triptykon
DAZZLE VISION
RatDog, The Dead
Turisas
Panic Cell
UTEZ, Strings 24
Lucas Yaksic Band
ex. derZbeZ, PUGS
Solo Artist
My New Zoo
Hämatom
Pestilence
Independent
O'Funk'illo
Cypher
Sonata Arctica
Panic Cell
Head
Vanishing Point
RT
Rancorous
Fozzy, Stuck Mojo
Triptykon
DAZZLE VISION
RatDog, The Dead
Turisas
Panic Cell
UTEZ, Strings 24
Lucas Yaksic Band
ex. derZbeZ, PUGS
Solo Artist
My New Zoo
Hämatom
Pestilence
Independent
O'Funk'illo
Cypher
Sonata Arctica
Panic Cell
Head
Vanishing Point
RT
Rancorous
Fozzy, Stuck Mojo
Triptykon
DAZZLE VISION
RatDog, The Dead
Turisas
Panic Cell
UTEZ, Strings 24
Lucas Yaksic Band
ex. derZbeZ, PUGS
Solo Artist
My New Zoo
Hämatom
Pestilence
Independent
O'Funk'illo
Cypher
Sonata Arctica
Panic Cell
Head
Vanishing Point
RT
Rancorous
Fozzy, Stuck Mojo
Triptykon
DAZZLE VISION
RatDog, The Dead
Turisas
Panic Cell
UTEZ, Strings 24
Lucas Yaksic Band
ex. derZbeZ, PUGS
Solo Artist
My New Zoo
Hämatom
Pestilence
Independent
O'Funk'illo
Cypher
Sonata Arctica
Panic Cell
Head
Vanishing Point
RT
Rancorous
Fozzy, Stuck Mojo
Triptykon
DAZZLE VISION
RatDog, The Dead
Turisas
Panic Cell
UTEZ, Strings 24
Lucas Yaksic Band
ex. derZbeZ, PUGS
Solo Artist
My New Zoo
Hämatom
Pestilence
Independent
O'Funk'illo
Cypher
Sonata Arctica
Panic Cell
Head
Vanishing Point
RT
Rancorous
Fozzy, Stuck Mojo
Triptykon
DAZZLE VISION
RatDog, The Dead
Turisas
Panic Cell
UTEZ, Strings 24
Lucas Yaksic Band
ex. derZbeZ, PUGS
Solo Artist
My New Zoo
Hämatom
Pestilence
Independent
O'Funk'illo
Cypher
Sonata Arctica
Panic Cell
Head
Vanishing Point
RT
Rancorous
Fozzy, Stuck Mojo
Triptykon
DAZZLE VISION
RatDog, The Dead
Turisas
Panic Cell
UTEZ, Strings 24
Lucas Yaksic Band
ex. derZbeZ, PUGS
Solo Artist
My New Zoo
Hämatom
Pestilence
Independent
O'Funk'illo
Cypher
Sonata Arctica
Panic Cell
Head
Vanishing Point
RT
Rancorous
Fozzy, Stuck Mojo
Triptykon
DAZZLE VISION
RatDog, The Dead
Turisas
Panic Cell
UTEZ, Strings 24
Lucas Yaksic Band
ex. derZbeZ, PUGS
Solo Artist
My New Zoo
Hämatom
Pestilence
Independent
O'Funk'illo
Cypher
Sonata Arctica
Panic Cell
Head
Vanishing Point
RT
Rancorous
Fozzy, Stuck Mojo
Triptykon
DAZZLE VISION
RatDog, The Dead
Turisas
Panic Cell
UTEZ, Strings 24
Lucas Yaksic Band
ex. derZbeZ, PUGS
Solo Artist
My New Zoo
Hämatom
Pestilence
Independent
O'Funk'illo
Cypher
Sonata Arctica
Panic Cell
Head
Vanishing Point
RT
Rancorous
Fozzy, Stuck Mojo
Triptykon
DAZZLE VISION
RatDog, The Dead
Turisas
Panic Cell
UTEZ, Strings 24
Lucas Yaksic Band
ex. derZbeZ, PUGS
Solo Artist
My New Zoo
Hämatom
Pestilence
Independent
O'Funk'illo
Cypher
Sonata Arctica
Panic Cell
Head
Vanishing Point
RT
Rancorous
Fozzy, Stuck Mojo
Triptykon
DAZZLE VISION
RatDog, The Dead
Turisas
Panic Cell
UTEZ, Strings 24
Lucas Yaksic Band
ex. derZbeZ, PUGS
Solo Artist
My New Zoo
Hämatom
Pestilence
Independent
O'Funk'illo
Cypher
Sonata Arctica
Panic Cell
Head
Vanishing Point
RT
Rancorous
Fozzy, Stuck Mojo
Triptykon
DAZZLE VISION
RatDog, The Dead
Turisas
Panic Cell
UTEZ, Strings 24
Lucas Yaksic Band
ex. derZbe

TABLE OF CONTENTS

	SOLID BODY ELECTRIC GUITARS
2 - 3	Intro
4 - 5	JEM/UV
6 - 11	RG Prestige
12 - 13	RG Premium
14	APEX
15	MTM
16 - 18	RG Tremolo
19	PGM
20 - 21	RG Fixed
22	GRC/GRX
23	MIKRO
24	AT
26 - 28	RGA
29 - 30	GRGA
31	DTT/DN
32 - 33	Xihpos/Iceman
34 - 35	RGD
36 - 37	JS
38	EGEN/STM
39	S Prestige
40 - 41	S
42 - 43	ARZ
44 - 46	ART/ARX
47	GART
48 - 49	SV Prestige/SA/GSA
50	FR
51	ORM/NDM
52 - 53	Guitar Jump Start HOLLOW BODY GUITARS
56	GB
57	PM/JSM
58	Artcore Custom
59	AK
60 - 61	AF/AFS
62 - 63	AG/AGR
64 - 65	AS
66	AM/AMF
	ELECTRIC BASSES
68 - 69	SR Premium
70 - 79	SR
80	K5/PIB
81	SRT
82 - 83	SRA
84	ATK
85	PGB
86	SRX
87	MDB/SDB
88	BTB
89	Artcore Bass
90 - 93	GSR/GSRM
94	GATK/GARTB
95	Bass Jump Start
96	GVB
97	GWB
98 - 99	Grooveline
100	ATK Prestige
101 - 102	SR Sprestige
	ELECTRONICS/ACCESSORIES
104	TSA
105	Tone Blaster X
106	Wholetone/IBZ amps
107	Sound Wave
108 - 109	Promethean
110 - 112	Effect Pedals
113	Tuners/Cases
114 - 115	Bags/Cases/Straps/Picks
	OTHERS
116 - 117	Pickup Specifications/Bass EQ Diagrams
118 - 119	Pickup Switching Systems/Neck Dimensions

As the world changes, musical trends change, and the Ibanez lineup continually evolves along with these shifts. However, one constant remains: the passion and effort Ibanez puts forth to offer the best in musical instruments, suited to YOUR style and suited to where YOU are in your musical development. That's why you'll see a wide range of instruments listed in these pages. Ibanez knows that every musician is different and wants the instrument that is right for them.

If you are into the heaviest of metal, Ibanez has the downtuned RGD series. If you prefer a single-cutaway but still need to shred, we have the 24-fret ARZ. We can also take you to even further extremes, or to the completely opposite side, like with Ibanez's huge variety of Artcore hollow body guitars.

For the more experienced player, we have the Prestige models, which offer the ultimate in Ibanez craftsmanship down to the last detail. And for those about to make a first step into this great world of music, we have a wide selection of GIO models, each of which we are proud to say offers true Ibanez quality. For 2011, we now offer the new Premium series of guitars designed for hardworking musicians. These guitars are for players who push their guitars to the fullest every night on stage and who demand real professional quality instruments both functionally and visually.

HERE ARE YOUR CHOICES ENJOY

YOUR SEARCH YOU'RE SURE TO FIND YOUR IBANEZ

Ibanez





STEVE VAI SIGNATURE MODELS

Steve Vai is one of the few guitarists universally acknowledged as one who has changed the way musicians think about what a guitar can really do. His signature Ibanez guitars are no different: Iconic, Sublime, Awe-Inspiring, Outrageous. The Ibanez JEM Series models are trailblazers in a world of imitators – there's nothing like them.

Photo by Meeno Peluce



JEM77 FP2

- 5pc JEM Maple/Walnut neck *Prestige*
- Basswood body
- W/6105 frets
- Edge bridge
- DiMarzio® Evolution® (H) neck pu
- DiMarzio® Evolution® (S) mid pu
- DiMarzio® Evo2™ (H) bridge pu
- Hardware color: Chrome
- Scale: 648mm/25.5"
- Color: FP2 (Floral Pattern 2)



JEM7V WH

- 5pc JEM Maple/Walnut neck *Prestige*
- Alder body
- W/6105 frets
- Edge bridge
- DiMarzio® Evolution® (H) neck pu
- DiMarzio® Evolution® (S) mid pu
- DiMarzio® Evolution® (H) bridge pu
- Hardware color: Gold
- Scale: 648mm/25.5"
- Color: WH (White)



JEM77V BK

- 5pc JEM Maple/Walnut neck *Prestige*
- Basswood body
- W/6105 frets
- Edge bridge
- DiMarzio® Breed™ (H) neck pu
- DiMarzio® Breed™ (S) mid pu
- DiMarzio® Breed™ (H) bridge pu
- Hardware color: Chrome
- Scale: 648mm/25.5"
- Color: BK (Black)



JEM505 BK
BK (Black)

JEM505

- 5pc JEM Maple/Walnut neck *Prestige*
- Basswood body
- W/6105 frets
- Edge bridge
- V7 (H) neck pu
- S1 (S) mid pu
- V8 (H) bridge pu
- Hardware color: Cosmo Black
- Scale: 648mm/25.5"
- Colors: WH (White) BK (Black)



JEM505 WH
WH (White)



UV777 BK

- 5pc UV Maple/Wenge neck *Prestige*
- Basswood body
- Jumbo frets
- Lo-Pro Edge 7 bridge
- DiMarzio® Blaze™ (H) neck pu
- DiMarzio® Blaze™ (S) mid pu
- DiMarzio® Blaze™ (H) bridge pu
- Hardware color: Chrome
- Scale: 648mm/25.5"
- Color: BK (Black)

RG *Prestige*

The RG is the most recognizable and distinctive guitar in the Ibanez line. Forged in the fires of 80's metal, this high-performance machine was built with speed and strength in mind. Whether using a locking tremolo with a sharp action knife edge or a hardtail bridge, the RG is a precision instrument.



Dexter Holland
—The Offspring



SPLIT-5 PICKUP SWITCHING SYSTEM H-S-H (5WAY)

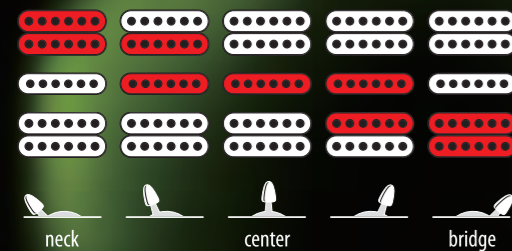

RG3570Z CA
CA (Candy Apple)

RG3570Z LB
LB (Laser Blue)

RG3250MZ FOB
FOB (Frozen Ocean Blue)

RG3250MZ DY
DY (Desert Sun Yellow)

RG3570Z

- 5pc Super Wizard HP Maple/Walnut neck *Prestige* w/KTS™ TITANIUM Reinforcement
- Basswood body • Jumbo frets
- Edge-Zero bridge w/ZPS3
- DiMarzio® Air Norton™ (H) neck pu
- DiMarzio® True Velvet™ (S) mid pu
- DiMarzio® Tone Zone® (H) bridge pu
- Hardware color : Cosmo Black
- Scale : 648mm/25.5"
- Colors : CA (Candy Apple) LB (Laser Blue)

RG3250MZ

- 5pc Super Wizard HP Maple/Walnut neck *Prestige* w/KTS™ TITANIUM Reinforcement
- Basswood body • Jumbo frets
- Edge-Zero bridge w/ZPS3
- DiMarzio® Air Norton™ (H) neck pu
- DiMarzio® True Velvet™ (S) mid pu
- DiMarzio® Tone Zone® (H) bridge pu
- Hardware color : Cosmo Black
- Scale : 648mm/25.5"
- Colors : FOB (Frozen Ocean Blue) DY (Desert Sun Yellow)



SUPER WIZARD HP NECK (HP=HIGH PERFORMANCE)

More comfortable neck feel, smoother neck shape, while retaining same thin profile as before — 17.0mm (at 1st fret).

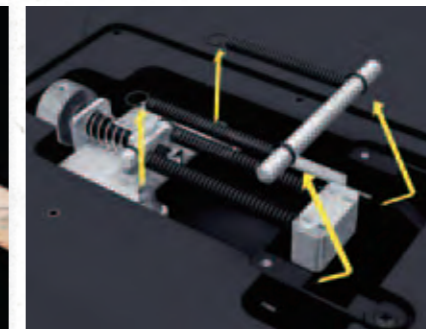

ZPS3 Zero Point System

The ZPS3 is the next stage of Zero Point Systems. Made of lightweight Duralumin, the addition of two outer springs makes the guitar easier to tune and provides much greater tuning stability. If you prefer a full floating tremolo setup, simply remove the stop bar.



Edge-Zero Tremolo

The Edge-Zero has a sharp knife-edge for extremely accurate tremolo playing. This tremolo also uses Ibanez innovations to keep string action constant and the bridge surface smooth. The specially designed arm socket prevents unnecessary wobble from the arm while providing full control over the arm's torque.



Mårten Hagström
—Meshuggah



Fredrik Thordendal
—Meshuggah



RG Prestige

RG3550MZ GK
GK (Galaxy Black)

RG3550MZ GW
GW (Galaxy White)

RG3770Z CAB

- 5pc Super Wizard HP Maple/Walnut neck *Prestige* w/KTS™ TITANIUM Reinforcement
- Basswood body
- Jumbo frets
- Edge-Zero bridge w/ZPS3
- DiMarzio® Air Norton™ (H) neck pu
- DiMarzio® True Velvet™ (S) mid pu
- DiMarzio® Tone Zone® (H) bridge pu
- Hardware color : Cosmo Black
- Scale : 648mm/25.5"
- Color : CAB (Caribbean Blue Lagoon)

RG3550MZ

- 5pc Super Wizard HP Maple/Walnut neck *Prestige* w/KTS™ TITANIUM Reinforcement
- Basswood body
- Jumbo frets
- Edge-Zero bridge w/ZPS3
- DiMarzio® Air Norton™ (H) neck pu
- DiMarzio® True Velvet™ (S) mid pu
- DiMarzio® Tone Zone® (H) bridge pu
- Hardware color : Cosmo Black
- Scale : 648mm/25.5"
- Colors : GK (Galaxy Black) GW (Galaxy White)



DIMARZIO® AIR NORTON™ PICKUP
The tone is deep and warm, but not muddy. Hot, but not distorted. It's even got cool harmonics, which are really unusual for a neck humbucker.

DIMARZIO® TRUE VELVET™ PICKUP
A vintage-style single-coil pickup that's clean and bright, but designed to still sound sweet when picking above the 12th fret. Coil is tuned to a frequency range that's bright but not thin.

DIMARZIO® TONE ZONE® PICKUP
Hot enough to qualify as a high-output pickup, but has a wider dynamic range – hard picking will produce a lot of power, and softer picking will be much cleaner and quieter.



RG1570 BK
BK (Black)

RG1570 CA
CA (Candy Apple)

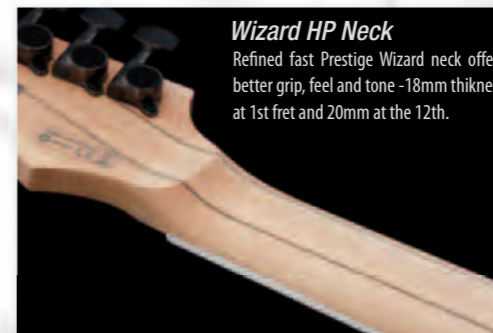

Wizard HP Neck

Refined fast Prestige Wizard neck offers better grip, feel and tone -18mm thickness at 1st fret and 20mm at the 12th.



RG1550M PBL
PBL (Phantom Blue)



RG1550M PPN
PPN (Poisoned Pumpkin)



RG1550M
WHP (White Plaster)



RG1570

- 5pc Wizard HP Maple/Walnut neck *Prestige*
- Basswood body
- Jumbo frets
- Edge-Zero bridge w/ZPS3
- V7 (H) neck pu
- S1 (S) mid pu
- V8 (H) bridge pu
- Hardware color : Cosmo Black
- Scale : 648mm/25.5"
- Colors : BK (Black) CA (Candy Apple)

VINTAGE 7 PICKUP

Tight, but bright. Very dynamic for chording and rhythm.

SINGLE 1 PICKUP

Traditional-sounding yet high output single coil with Alnico-5 polepieces for even string output. Designed to work with humbuckers in the split position.

VINTAGE 8 PICKUP

Warm yet articulate lead pickup with enhanced overtones. Good harmonics without excessive brightness.

RG1550M

- 5pc Wizard HP Maple/Walnut neck *Prestige*
- Basswood body
- Jumbo frets
- Edge-Zero bridge w/ZPS3
- V7 (H) neck pu
- S1 (S) mid pu
- V8 (H) bridge pu
- Hardware color : Cosmo Black
- Scale : 648mm/25.5"
- Colors : PBL (Phantom Blue)
PPN (Poisoned Pumpkin)
WHP (White Plaster)

RG1550M BKL

- Left-Handed
- 5pc Wizard HP Maple/Walnut neck *Prestige*
- Basswood body
- Jumbo frets
- Edge-Zero bridge w/ZPS3
- V7 (H) neck pu
- S1 (S) mid pu
- V8 (H) bridge pu
- Hardware color : Cosmo Black
- Scale : 648mm/25.5"
- Colors : BK (Black)





RG1451 AG
AG (Aluminum Gray)

RG1451 NC
NC (Night Crow)

RG1451

- 5pc Wizard HP Maple/Walnut neck *Prestige*
- Basswood body
- Jumbo frets
- Tight-End bridge
- V6F (H) neck pu
- RTS (S) mid pu
- V6F2 (H) bridge pu
- Hardware color : Cosmo Black
- Scale : 648mm/25.5"
- Colors : AG (Aluminum Gray) NC (Night Crow)

RG
Prestige

Tight-End bridge

The Tight-End bridge integrates every aspect of the bridge design in rigidity and accuracy. Saddles are firmly locked onto the base plate for maximum string vibration, and remain perfectly linear during intonation adjustment for the most accurate set up. The saddle height can be adjusted individually by one screw. Also, the top side of the bridge is smooth finished. So if you play hard, the Tight-End bridge will forgive you and your hands.



**RG(H-H) pickup switching system
H-H (5WAY)**

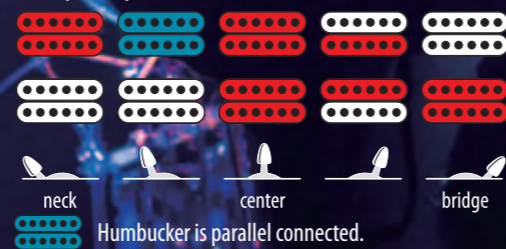

Elias Viljanen
-Sonata Arctica



FX EDGE III-8 Bridge
RG2228's Fixed Edge III-8 bridge combines fixed bridge sustain and double-locking stability.



Tony MacAlpine



RG1527 BK

- 5pc Wizard-7 Maple/Wenge neck *Prestige*
- Basswood body
- Jumbo frets
- Edge-Zero 7 bridge w/ZPS3
- V77 (H) neck pu
- V87 (H) bridge pu
- Hardware color : Cosmo Black
- Scale : 648mm/25.5"
- Color : BK (Black)



RG1527M GW

- 5pc Wizard-7 Maple/Wenge neck *Prestige*
- Basswood body
- Jumbo frets
- Edge-Zero 7 bridge w/ZPS3
- V77 (H) neck pu
- V87 (H) bridge pu
- Hardware color : Cosmo Black
- Scale : 648mm/25.5"
- Color : GW (Galaxy White)



RG2228 GK

- 5pc Ultra-8 Maple/Wenge neck *Prestige* w/KTS™ TITANIUM Reinforcement
- Basswood body
- Jumbo frets
- FX Edge III-8 bridge
- EMG® 808 (H) neck pu
- EMG® 808 (H) bridge pu
- Hardware color : Black
- Scale : 685.8mm/27"
- Factory Tuning: 1D#, 2A#, 3F#, 4C#, 5G#, 6D#, 7A#, 8F
- String Gauge: .009/ .011/ .016/ .024/ .032/ .042/ .054/ .065
- Color : GK (Galaxy Black)

RG PREMIUM

RG models are made to be played, and played a lot. Among our various lines, the RG Premium can be recognized as the ultimate workhorse guitar for today's hardworking musician.

The combination of brand new Ibanez Edge-Zero II tremolo with ZPS, and elaborated craft processes, promises you perfect tuning stability and playing comfort. Also the DiMarzio® ibz pickups maximize the potential of the gear to produce the tone you desire.

Terry Balsamo
— *Evanescence*



RG920QM BI
BI (Black Ice)

RG920QM LI
LI (Liquid Inferno)

RG920QM CBE
CBE (Cobalt Blue Surge)

RG920QM RDT
RDT (Red Desert)

RG920QM HVV
HVV (High Voltage Violet)

RG870 BK

- 5pc Wizard Maple/Walnut neck
- American Basswood body
- Jumbo frets
- Edge-Zero II bridge w/ZPS3Fe
- CAP-VM1 (H) neck pu
- CAP-VM1S (S) mid pu
- CAP-VM2 (H) bridge pu
- Hardware color: Cosmo Black
- Scale: 648mm/25.5"
- Color: BK(Black)

RG920QM

- 5pc Wizard Maple/Walnut neck
- Quilted Maple top / American Basswood body
- Jumbo frets
- Edge-Zero II bridge w/ZPS3Fe
- DiMarzio® ibz (H) neck pu
- DiMarzio® ibz (H) bridge pu
- Hardware color: Cosmo Black
- Scale: 648mm/25.5"
- Colors: BI (Black Ice) LI (Liquid Inferno)
CBE (Cobalt Blue Surge) RDT (Red Desert)
HVV (High Voltage Violet)

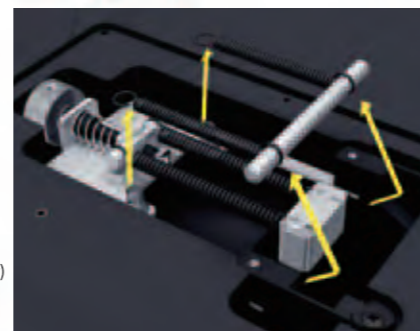

ZPS3 Zero Point System

The ZPS3 is the next stage of Zero Point Systems. The addition of two outer springs makes the guitar easier to tune and provides much greater tuning stability. If you prefer a full floating tremolo setup, simply remove the stop bar.

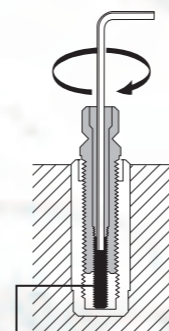

Stud Lock bolt Stud Lock Screws

Lock the stud bolts for maximum string vibration to the body.



Edge Zero II

Installation of the Zero Point System in the Edge Zero II makes tuning easier and faster as well as providing stable tuning for long performances, all while maintaining smooth tremolo playing. Loss of tuning is kept to a minimum even when a string breaks. For players that prefer a full floating system, simply remove the stop bar.



DiMarzio® Ibz Pickups

DiMarzio® ibz pickups were made by DiMarzio® specially for Ibanez. The tone is vivid but easy to control to your sonic requirement.



Wizard Premium Neck

The Wizard neck on RG Premium models is following the same playability and comfort on its Prestige counterpart. 18mm thickness at 1st fret and 20mm at the 12th.

RG(H-H) pickup switching system H-H (5WAY)

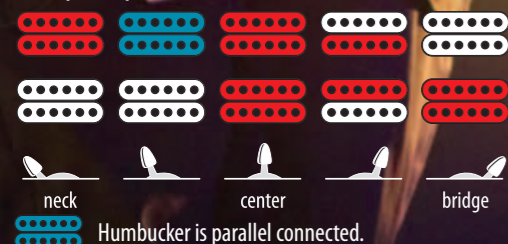



Photo by Sebastien Paquet

Photo by Scott Uchida

Slipknot

MICK THOMSON SIGNATURE MODELS

That tightness around your throat. Getting harder to breathe. Slipknot guitarist Mick Thomson's signature models have a way of doing that. With their high-output Seymour Duncan Blackouts™ EMTY™ active pickups and Edge FX bridges, these low-tuned axes churn out demonic metal so unholy, it might make some people uncomfortable. In a good way.



APEX100 TFB

- 5pc APEX Maple/Wenge neck *Prestige*
- Alder body
- Jumbo frets
- Lo-Pro Edge 7 bridge w/U-bar
- DiMarzio® Blazex™ (S) neck pu
- DiMarzio® Blazex™ (H) bridge pu
- Hardware color : Powdered Cosmo Black
- Scale : 648mm/25.5"
- Factory tuning : 1D, 2A, 3F, 4C, 5G, 6D, 7A
- String gauge: .010/.013/.017/.030/.042/.052/.060
- Color : TFB (Tri Fade Burst)

MUNKY Korn SIGNATURE MODELS

With Korn, Munky took a 7-seven string shred machine and turned it into a lowend bone crusher. His signature beast, The APEX, enters 2011 with a new look featuring a stunning sunburst finish and classic white pickguard.

APEX2 GSF

- 5pc APEX2 Maple/Walnut neck
- Mahogany body
- Jumbo frets
- Tone Pros® 7 bridge
- DiMarzio® Paf 7™ (H) neck pu
- DiMarzio® Paf 7™ (H) bridge pu
- Hardware color : Powdered Cosmo Black
- Scale : 648mm/25.5"
- Factory tuning : 1D, 2A, 3F, 4C, 5G, 6D, 7A
- String gauge: .010/.013/.017/.026/.036/.046/.054
- Color : GSF (Green Shadow Flat)

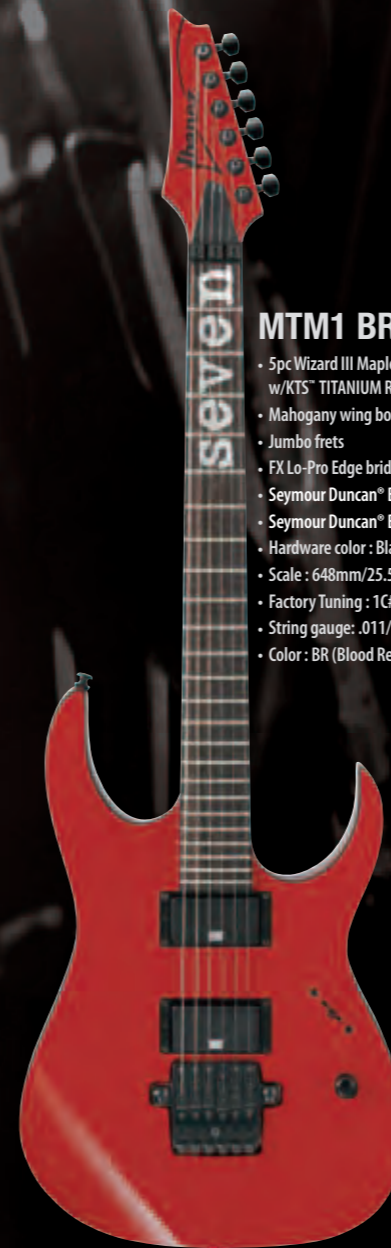

MTM1 BR

- 5pc Wizard III Maple/Walnut neck-thru w/KTS™ TITANIUM Reinforcement
- Mahogany wing body
- Jumbo frets
- FX Lo-Pro Edge bridge
- Seymour Duncan® Blackouts™ EMTY™ (H) neck pu
- Seymour Duncan® Blackouts™ EMTY™ (H) bridge pu
- Hardware color : Black
- Scale : 648mm/25.5"
- Factory Tuning : 1C#, 2G#, 3E, 4B, 5F#, 6B
- String gauge: .011/.014/.018/.028/.038/.049
- Color : BR (Blood Red)



MTM2

- 5pc Wizard III Maple/Walnut neck
- Mahogany body
- Jumbo frets
- FX Edge III bridge
- Duncan® HB-105MT (H) neck pu
- Duncan® HB-105MT (H) bridge pu
- Hardware color : Black
- Scale : 648mm/25.5"
- Factory Tuning : 1C#, 2G#, 3E, 4B, 5F#, 6B
- String gauge: .011/.014/.018/.028/.038/.049
- Colors : WH (White) BK (Black)

MTM2 WH

WH (White)

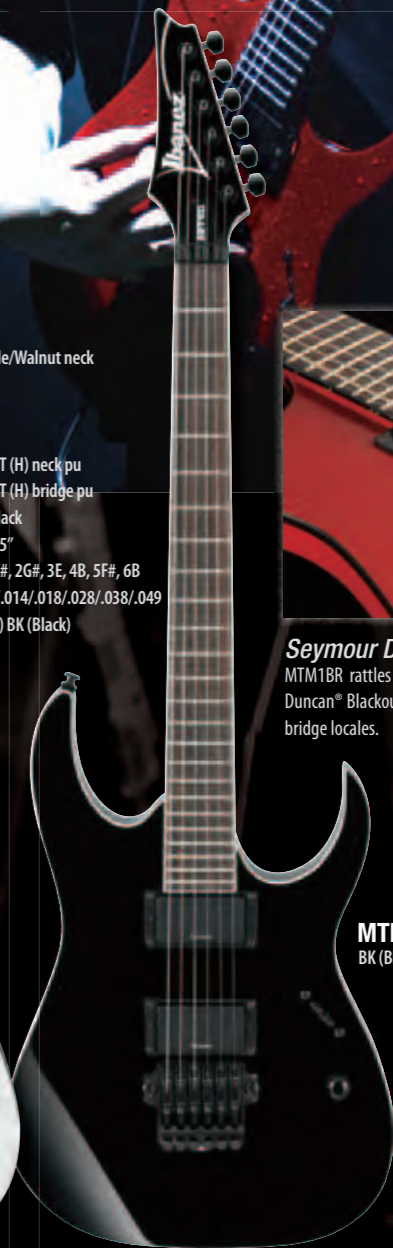

MTM2 BK

BK (Black)

Seymour Duncan® Blackouts™ Pickups

MTM1BR rattles the walls with high-output Seymour Duncan® Blackouts™ EMTY™ active pickups, at neck and bridge locales.

RG TREMOLO

RG Tremolo models stand up to the most abusive whammy bar users around. Now featuring the Edge Zero II tremolo with the Zero Point System, tuning stability is maximized. Lightning fast fretboard work is no problem with the Wizard neck, flat fingerboard, and jumbo frets.



RG470AH NTF

- 3pc Wizard III Maple neck
- Ash body
- Jumbo frets
- Edge-Zero II bridge w/ZPS3Fe
- INF1 (H) neck pu
- INF51 (S) mid pu
- INF2 (H) bridge pu
- Hardware color : Cosmo Black
- Scale : 648mm/25.5"
- Color : NTF (Natural Flat)

RG470MH MOL

MOL (Mahogany Oil)

RG470MH

- 3pc Wizard III Maple neck
- Mahogany body
- Jumbo frets
- Edge-Zero II bridge w/ZPS3Fe
- INF1 (H) neck pu
- INF51 (S) mid pu
- INF2 (H) bridge pu
- Hardware color : Cosmo Black
- Scale : 648mm/25.5"
- Colors : MOL (Mahogany Oil)
- BB (Blackberry)

RG470MH BB

BB (Blackberry)



Bobby Thompson
—Job For A Cowboy



Tosin Abasi
—Animals as Leaders
Photo by Priscilla Lima

SPLIT-5 PICKUP SWITCHING SYSTEM H-S-H (5WAY)

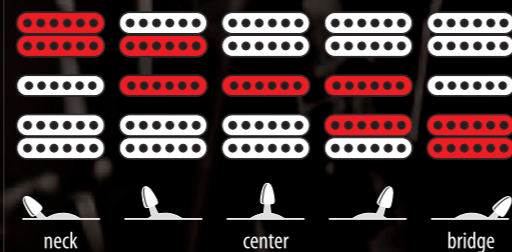

Wizard III neck

Fast, Flat and thin Wizard III necks for speed and comfort.



RG350MP WH

- 3pc Wizard III Maple neck
- Basswood body
- Jumbo frets
- Edge-Zero II bridge w/ZPS3Fe
- INF3 (H) neck pu
- INF53 (S) mid pu
- INF4 (H) bridge pu
- Hardware color : Black
- Scale : 648mm/25.5"
- Color : WH (White)



RG350M RGM

RGM (Roadster Green Metallic)

RG350M

- 3pc Wizard III Maple neck
- Basswood body
- Jumbo frets
- Edge-Zero II bridge w/ZPS3Fe
- INF3 (H) neck pu
- INF53 (S) mid pu
- INF4 (H) bridge pu
- Hardware color : Black
- Scale : 648mm/25.5"
- Colors : RGM (Roadster Green Metallic)
- YE (Yellow)
- SLB (Starlight Blue)



RG350M YE

YE (Yellow)



RG350M SLB

SLB (Starlight Blue)



RG350DX WH

- 3pc Wizard III Maple neck
- Basswood body
- Jumbo frets
- Edge-Zero II bridge w/ZPS3Fe
- INF3 (H) neck pu
- INF53 (S) mid pu
- INF4 (H) bridge pu
- Hardware color : Black
- Scale : 648mm/25.5"
- Color : WH (White)



RG350EX BK

- 3pc Wizard III Maple neck
- Basswood body
- Jumbo frets
- Edge-Zero II bridge w/ZPS3Fe
- INF3 (H) neck pu
- INF53 (S) mid pu
- INF4 (H) bridge pu
- Hardware color : Cosmo Black
- Scale : 648mm/25.5"
- Color : BK (Black)

Stud Lock Screws

Lock the stud bolts for maximum string vibration to the body.

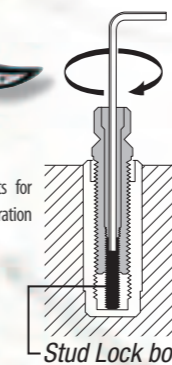

Edge Zero II

Installation of the Zero Point System in the Edge Zero II makes tuning easier and faster as well as providing stable tuning for long performances, all while maintaining smooth tremolo playing. Loss of tuning is kept to a minimum even when a string breaks. For players that prefer a full floating system, simply remove the stop bar.

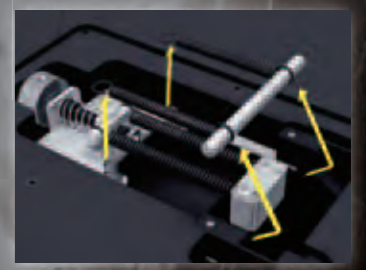

ZPS3 Zero Point System

The ZPS3 is the next stage of Zero Point Systems. The addition of two outer springs makes the guitar easier to tune and provides much greater tuning stability. If you prefer a full floating tremolo setup, simply remove the stop bar.



RG370DX BK
BK (Black)

- RG370DX**
- 3pc Wizard III Maple neck
 - Basswood body
 - Jumbo frets
 - Edge-Zero II bridge w/ZPS3Fe
 - INF3 (H) neck pu • INF53 (S) mid pu • INF4 (H) bridge pu
 - Hardware color : Black
 - Scale : 648mm/25.5"
 - Colors : BK (Black) / WH (White) / ROM (Roadster Orange Metallic)



RG370DX WH
WH (White)



RG370DX ROM
ROM (Roadster Orange Metallic)

RG(H-S-H) pickup switching system
H-S-H (5WAY)

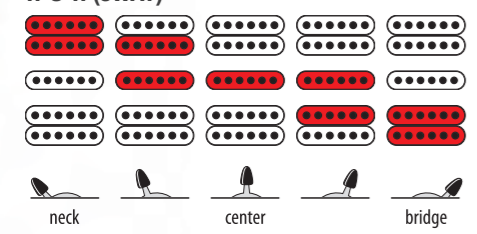

RG TREMOLO



- RG370DX BKL**
- Left-Handed
 - 3pc Wizard III Maple neck
 - Basswood body
 - Jumbo frets
 - Edge-Zero II bridge w/ZPS3Fe
 - INF3 (H) neck pu • INF53 (S) mid pu • INF4 (H) bridge pu
 - Hardware color : Black • Scale : 648mm/25.5"
 - Color : BK (Black)



- RG7320 BK**
- 5pc Wizard II-7 Maple/Walnut neck
 - Basswood body
 - Jumbo frets
 - Edge-Zero II-7 bridge w/ZPS3Fe
 - AH1-7 (H) neck pu • AH2-7 (H) bridge pu
 - Hardware color : Black • Scale : 648mm/25.5"
 - Color : BK (Black)



PAUL GILBERT
SIGNATURE MODEL

Paul Gilbert thrashes and rolls only with the best of instruments, namely his own. His signature PGM401 delivers with a rough and tumble combination of shred playability and warm tone just where you want it.

MR. BIG



Tilt Neck Joint
The traditional neck joint has a metal plate with 4 screws, yet the tilt joint still offers easy upper fret access. Paul likes this original neck joint for its tonal characteristics.

Photo by Larry DiMarzio



- PGM401 TFB**
- 5pc PGM Maple/Walnut neck *Prestige*
 - Ash body
 - Medium frets
 - Fixed bridge
 - DiMarzio® Air Classic™ (H) neck pu
 - DiMarzio® Air Classic™ (H) bridge pu
 - Hardware color : Cosmo Black
 - Scale : 648mm/25.5"
 - Color : TFB (Tri Fade Burst)



Ryan Leitrü
 -For Today

RG FIXED

Sometimes keeping things simple is the way to go. The RG Fixed series is for players who prefer a straightforward fixed bridge setup.



RG471AH NTF

- 3pc Wizard III Maple neck
- Ash body
- Jumbo frets
- Gibraltar Standard bridge
- INF1 (H) neck pu
- INFS1 (S) mid pu
- INF2 (H) bridge pu
- Hardware color : Cosmo Black
- Scale : 648mm/25.5"
- Color : NTF (Natural Flat)



RG321MH

- 3pc Wizard III Maple neck
- Mahogany body
- Jumbo frets
- Gibraltar Standard bridge
- INF3 (H) neck pu
- INF4 (H) bridge pu
- Hardware color : Cosmo Black
- Scale : 648mm/25.5"
- Colors : BBS (Blackberry Sunburst)
 BK (Black) MOL (Mahogany Oil Finish)

RG321MH BBS

BBS (Blackberry Sunburst)



RG321MH BK

BK (Black)



RG321MH MOL

MOL (Mahogany Oil)



RG7321FM BBS

- 5pc Wizard II-7 Maple/Walnut neck
- Basswood body
- Jumbo frets
- Gibraltar Standard 7 bridge
- AH1-7 (H) neck pu
- AH2-7 (H) bridge pu
- Hardware color : Cosmo Black • Scale : 648mm/25.5"
- Color : BBS (Blackberry Sunburst)



RG7321 BK

- 5pc Wizard II-7 Maple/Walnut neck
- Basswood body
- Jumbo frets
- Gibraltar Standard 7 bridge
- AH1-7 (H) neck pu
- AH2-7 (H) bridge pu
- Hardware color : Black • Scale : 648mm/25.5"
- Color : BK (Black)

Gibraltar Standard Bridge

RG Fixed Series feature the Gibraltar Standard Bridge. Ready and able for wide intonation adjustment, but rock solid in standing up to the most aggressive playing. A bridge made for crossing the great divide over to heavier rock.



Thru-Body Stringing

All RG fixed models through-body stringing increases sustain.



GIO

Whether you're a beginner looking for your first electric, or a working pro looking for a good backup for your main axe, the Ibanez GIO series delivers. GRG and GRX guitars feature the same playability, warranty and set-up as our most expensive instruments, but at rock bottom affordable prices.



GRG150DX BKN
BKN (Black Night)

GRG150DX PW
PW (Pearl White)

GRG150DX

- GRG1 Maple neck
- Basswood body
- Medium frets
- Fat 10 bridge
- PSND1 (H) neck pu
- PSNDS (S) mid pu
- PSND2 (H) bridge pu
- Hardware color : Chrome • Scale : 648mm/25.5"
- Colors : BKN (Black Night) PW (Pearl White)



GRG170DX BKN
BKN (Black Night)

GRG170DX CA
CA (Candy Apple)

GRG170DX

- GRG1 Maple neck
- Basswood body
- Medium frets
- Fat 10 bridge
- PSND1 (H) neck pu
- PSNDS (S) mid pu
- PSND2 (H) bridge pu
- Hardware color : Chrome • Scale : 648mm/25.5"
- Colors : BKN (Black Night) CA (Candy Apple)



GRX20Z BKN
BKN (Black Night) -Also available Left-Handed in BKN finish

GRX20Z JB
JB (Jewel Blue)

GRX20Z RD
RD (Red)

GRX20Z

- GRX Maple neck
- Basswood body
- Medium frets
- FAT6 bridge
- PSND1 (H) neck pu
- PSND2 (H) bridge pu
- Hardware color : Chrome
- Scale : 648mm/25.5"
- Colors : BKN (Black Night) JB (Jewel Blue) RD (Red)
- Also available left-handed in BKN finish

MIKRO

The little Mikro puts out sound way beyond its size – which is why, in just a few short years, it's become one of the most popular guitars in the history of Ibanez. Perfect for young rockers on the way up or seasoned road warriors on the tour bus. The mighty Mikro series includes left-handed models, vibrant colors and maple fretboards inspired by the classic 1987 "Ibanez Rebirth" RGs



GRGM21 BKN
BKN (Black Night)

GRGM21 BKNL
WH (White)

GRGM21

- GRGM Maple neck
- Basswood body • Medium frets
- Fixed bridge
- PSND1 (H) neck pu
- PSND2 (H) bridge pu
- Hardware color : Chrome
- Scale : 560mm/22"
- Colors : BKN (Black Night) WH (White)



MIKRO ROSEWOOD FRETBOARD W/SHARKTOOTH
GRGM21 guitars feature sharktooth inlays for big metal looks on a compact axe.



GRGM21M RD
RD (Red)

GRGM21M JB
JB (Jewel Blue)

GRGM21M YL
YL (Yellow)

GRGM21 BKNL

- Left-Handed
- GRGM Maple neck
- Basswood body • Medium frets
- Fixed bridge
- PSND1 (H) neck pu
- PSND2 (H) bridge pu
- Hardware color : Chrome
- Scale : 560mm/22"
- Color : BKN (Black Night)

GRGM21M

- GRGM Maple neck
- Basswood body
- Medium frets • Fixed bridge
- PSND1 (H) neck pu
- PSND2 (H) bridge pu
- Hardware color : Chrome
- Scale : 560mm/22"
- Colors : RD (Red) JB (Jewel Blue) YL (Yellow)



MIKRO MAPLE FRETBOARD
GRGM21M's classic maple fretboard.



ANDY TIMMONS SIGNATURE MODEL

This multi-purpose axe has tone to spare, clean looks, and a configuration of DiMarzio® pickups bound to make any guitarist's playing sparkle.



AT100CL SB

- 1pc AT Maple neck *Prestige*
- Alder body
- Jumbo frets
- Wilkinson® Gotoh® VSVG bridge
- DiMarzio® Cruiser™ (H) neck pu
- DiMarzio® Cruiser™ (H) mid pu
- DiMarzio® AT1™ (H) bridge pu
- Hardware color: Chrome
- Scale: 648mm/25.5"
- Color: SB (Sunburst)

AT100CL / DiMarzio® AT-1™ Pickup
The AT-1™ bridge pickup was specially designed and wound by DiMarzio® for Andy Timmons



 Keith Aazami Bad Acid Trip	 Sean Andrews Redemption	 Cory Arford Carnifex	 Chris Arp Psypopus, Hank Williams III	 Matt Aub Timelord	 Karin Axelsson Sonic Syndicate	 Paul Baayens Hail of Bullets
 Daniel Bage Mutiny Within	 Rob Balducci	 Way Barrier Destroy Destroy Destroy	 Justin Bender Into Eternity	 Glen Benton Deicide	 Jett Beres Sister Hazel	 Troy Bleich Into Eternity
 Alex Bois Periphery	 Jake Bowen Periphery	 Dennis Bradley Beneath the Massacre	 Norman Brown	 Steve Brown The Soulless	 Fred Calderon Carnifex	 Noah Carpenter Skinless
 Cat Casino Deathstars	 Curtis Chambers Franklin Bridge	 Sebastien Chaput Ion Dissonance	 Audley Chisholm The Wailers	 Tony Choy Atheist, Area 305	 James Davies The Blackout	 Jim Davies Hyper, Victory Pill
 Mark Davis Emmure	 Skinny Disco Deathstars	 Ross Dolan Immolation	 Doug Doppler	 Fletcher Dragge Pennywise	 Nidas Engelin Engel	 Jon Finn Jon Finn Group
 Fuzz Rolla, Deep Banana Blackout	 Adriel Garcia City Sleeps	 Wes Geer	 Rocky George Fishbone	 Andreas Gerhard Aloha from Hell	 Josh Gilbert As I Lay Dying	 Matt Good From First to Last, D.R.U.G.S.
 Gravy Mushroomhead	 Ryan Gudmunds Carnifex	 Brandon Hackenson Greeley Estates	 Trent Hafdahl After The Burial	 Filip Hantusch War From a Harlot's Mouth	 AJ Harvey Last Chance to Reason	 Simon Hawemann War From A Harlot's Mouth
 Kasper Heikkinen Amberian Dawn, Guardians of Mankind	 Alex Hernandez	 Frank Hermann Adagio	 Sami Hinkka Ensiferum	 Pontus Hjelm Dead by April	 Steve Holt 36 Crazyfists	 Trond "Teen" Holter Wig Wam
 Bernhard Horn Callejon	 Bill Hudson Written in Blood, Circle II Circle	 Scott Hull Pig Destroyer	 Kenneth Iain Duncan We Butter the Bread with Butter	 Nightmare Industries Deathstars	 Anders Iwers Tiamat	 Trú James Stone Mecca
 Bernt "Flash" Jansen Wig Wam	 Percy Jones	 Juan Juarez Bonded by Blood	 Jari Kainulainen Symfonia	 Joe Keyser Skinless	 Jon Kita Diecast	 Ryan Knight The Black Dahlia Murder

RGA

The RGA archtop guitar not only has curves but playability. And for live performance, its lightweight body gives players more freedom to move on stage. The arched top also allows players to knock down heavy riffs and power chords without hitting the guitar body. Curved beauty and great performance combine gracefully in the RGA.

RGA420Z DSH

- 5pc Wizard HP Maple/Walnut neck *Prestige*
- Flamed Maple top/Mahogany body
- Jumbo frets
- Edge-Zero bridge w/ZPS3
- CAP-LZ10 (H) neck pu
- CAP-LZ20 (H) bridge pu
- Hardware color : Cosmo Black
- Scale : 648mm/25.5"
- Color : DSH (Devil's Shadow)

RGA72TQME

- 3pc Wizard III Maple set-in neck w/KTS™ TITANIUM Reinforcement
- Quilted Maple top/Mahogany body
- Jumbo frets
- Edge-Zero II bridge w/ZPS3Fe
- EMG® 85 (H) neck pu
- EMG® 81 (H) bridge pu
- Hardware color : Cosmo Black
- Scale : 648mm/25.5"
- Colors : TGB (Transparent Gray Burst) BBS (Blackberry Sunburst)

RGA72QME TGB

- 3pc Wizard III Maple set-in neck w/KTS™ TITANIUM Reinforcement
- Quilted Maple top/Mahogany body
- Jumbo frets
- Gibraltar Standard bridge
- EMG® 85 (H) neck pu
- EMG® 81 (H) bridge pu
- Hardware color : Cosmo Black
- Scale : 648mm/25.5"
- Color : TGB (Transparent Gray Burst)

RGA72TQME TGB
TGB (Transparent Gray Burst)

RGA72QME BBS
BBS (Blackberry Sunburst)

EMG® Active Pickups

RGA72TQME/RGA72QME come equipped with EMG85/81 pickups. The bridge position creates razor sharp attack and incredible sustain while the neck position kicks out beefy lows and fattened highs.

CAP-LZ10/20

CAP-LZ10/20 are newly developed active pickups. They deliver high-power yet cut-through sound, and also minimize the noise even played with high gain setting. The CAP-LZ pickups cover very wide range, and offer strong but rich middle tone for fast and heavy riff and shred solo playing.



Dino Cazares
-Fear Factory

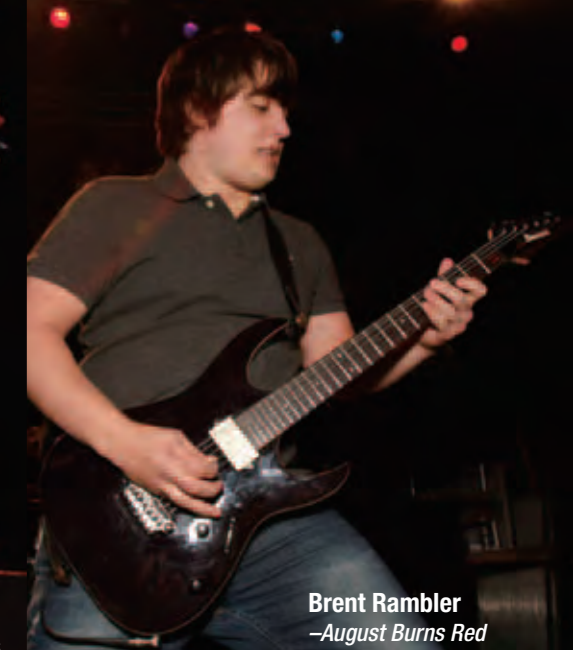

Brent Rambler
-August Burns Red



Matt Bachand
-Shadows Fall



Mark Jansen
-Epica, MaYaN



JB Brubaker
-August Burns Red



Brian Leppke
-Bleeding Through



Javier Reyes
-Animals as Leaders



Josh Travis
-The Tony Danza Tapdance Extravaganza
Photo by Chris Fulcher





RGA42FM BBB
BBB (Bright Blue Burst)



RGA42FM TRB
TRB (Transparent Red Burst)



RGA42FM TGB
TGB (Transparent Gray Burst)



RGA42FM

- 3pc Wizard III Maple neck
- Flamed Maple top/Mahogany body
- Jumbo frets
- Gibraltar Standard bridge
- CAP-LZ10 (H) neck pu
- CAP-LZ20 (H) bridge pu
- Hardware color : Cosmo Black
- Scale : 648mm/25.5"
- Colors : BBB (Bright Blue Burst)
TRB (Transparent Red Burst)
TGB (Transparent Gray Burst)

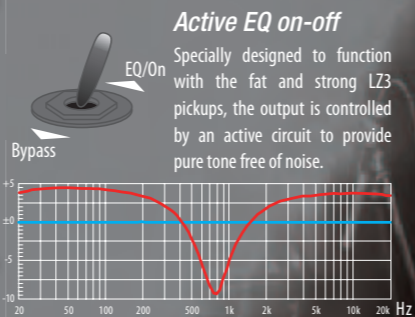

RGA7 BK

- 5pc Wizard II-7 Maple/Walnut neck
- Mahogany body • Jumbo frets
- Gibraltar Standard-7 bridge
- LZ7-N (H) neck pu
- LZ7-B (H) bridge pu
- Hardware color : Cosmo Black
- Scale : 648mm/25.5"
- Color : BK (Black)

RGA8 BK

- 5pc Wizard II-8 Maple/Walnut neck w/KTS™ TITANIUM Reinforcement
- Mahogany body • Jumbo frets
- FX Edge III-8 bridge
- LZ8-N (H) neck pu
- LZ8-B (H) bridge pu
- Hardware color : Black
- Factory tuning : 1D#, 2A#, 3F#, 4C#, 5G#, 6D#, 7A#, 8F
- String Gauge : .009/.011/.016/.024/.032/.042/.054/.065
- Scale : 685.8mm/27"
- Color : BK (Black)

Gibraltar Standard 7 bridge

The Gibraltar Standard is a simple fixed bridge that was designed to adhere firmly to the guitar body and make good transfer of the string vibrations. It is also incredibly smooth for maximum playing comfort.



FX EDGE III-8 Bridge

Ibanez FX EDGE III-8 double-locking fixed bridge was made specifically to handle and augment the awesome extended range of the RGA8 8-string.

GRGA

A guitar doesn't have to cost a bundle to sound good. The GIO series was developed for players who want Ibanez quality in a more affordable package. The newest addition is the GRGA42. With beautiful quilted maple art grain top and EMG-HZ pickups, it has everything you need for in a real metal guitar.



GRGA42TQA TBB
TBB (Transparent Blue Burst)



GRGA42TQA TKS
TKS (Transparent Black Sunburst)



GRGA42TQA TRB
TRB (Transparent Red Burst)



GRGA32T BKN
BKN (Black Night)



GRGA32T MGS
MGS (Metallic Gray Sunburst)



GRGA32T WH
WH (White)

GRGA42TQA

- GRGA maple neck
- Quilted Maple Art Grain top/Basswood body
- Medium frets
- Edge III bridge
- EMG® H4A neck pu
- EMG® H4 bridge pu
- Hardware color : Black
- Scale : 648mm/25.5"
- Colors : TBB (Transparent Blue Burst)
TKS (Transparent Black Sunburst)
TRB (Transparent Red Burst)



EMG®-HZ Pickups

The GRGA42TQA is equipped with EMG® HZ pickups.

GRGA32T

- GRGA1 Maple neck
- Mahogany body
- Medium frets
- Edge III bridge
- PSND1 (H) neck pu
- PSND2 (H) bridge pu
- Hardware color : Black
- Scale : 648mm/25.5"
- Colors : BKN (Black Night)
MGS (Metallic Gray Sunburst)
WH (White)



Edge III Tremolo

Ibanez has long been admired for the Edge tremolo, and the Edge III embodies all of the classic function of the original Edge with some modern updates. It features lower profile fine-tuners, much like the Lo-Pro Edge. There are also two screws in the arm pocket for easy adjustment of the arm height and torque.

GRGA



GRGA420A

- GRGA maple neck
- Quilted Maple Art Grain top / Basswood body
- Medium frets
- Fixed bridge
- EMG® H4A neck pu
- EMG® H4 bridge pu
- Hardware color : Black
- Scale : 648mm/25.5"
- Colors : TRB (Transparent Red Burst)
TKS (Transparent Black Sunburst)

GRGA420A TRB
TRB (Transparent Red Burst)

GRGA420A TKS
TKS (Transparent Black Sunburst)



GRGA32 MRS
MRS (Metallic Red Sunburst)

GRGA32

- GRGA1 Maple neck
- Mahogany body
- Medium frets
- Fixed bridge
- PSND1 (H) neck pu
- PSND2 (H) bridge pu
- Hardware color : Black
- Scale : 648mm/25.5"
- Colors : MRS (Metallic Red Sunburst) BKN (Black Night)



GRGA32 BKN
BKN (Black Night)



Barry Stock
–Three Days Grace



Isaac Delahaye
–Epica ,MaYaN

Photo by Audrey Dujardin / Shutterstock.net



Rikard Sundén
–Sabaton

Photo by davidsfoto.se

DARKSTONE

The DN is the new standard in heavy metal and heavy rock guitar. As its “Darkstone” series name suggests, strong construction and smart body style combine for a powerful, clean sound. The Tight-Tune Bridge is sturdy and resonant, and the tailpiece comes equipped with the Ball-End Stopper for more lock-in on strings – both are features originally designed by Ibanez.



DN500K BK
BK (Black)

DN500K

- DN Sapele set-in neck
- Sapele body • Medium frets
- Tight-Tune bridge • Tight-Tune tailpiece
- CAP-PP1-N (H) neck pu • CAP-PP1-B (H) bridge pu
- Hardware color : Cosmo Black
- Scale : 628mm/24.75"
- Colors : BK (Black) WH (White)

DN500K WH
WH (White)



Tight-Tune bridge & Tail piece

Solid as a rock, the Tight-Tune bridge and tailpiece were designed to lock down securely and prevent any kind of wobble or movement. Each saddle is locked into the base plate, and the bridge is anchored by stud bolts into the body of the guitar. Furthermore, the studs are also locked onto the base plate so that the maximum vibration from the string is transferred to the body.

DESTROYER

The Destroyer, a dark spectre from Ibanez's past – updated neck-thru construction and DiMarzio® D Activator-X™ pickups. You wanna rock hard?



DTT700 MGS

- 5pc Wizard III Maple/Walnut neck-thru w/KTS™ TITANIUM Reinforcement
- Mahogany wing body • Jumbo frets • Gibraltar Custom bridge
- DiMarzio® D Activator-X™ (H) neck pu • DiMarzio® D Activator-X™ (H) bridge pu
- Hardware color : Chrome • Scale : 648mm/25.5"
- Color : MGS (Metallic Gray Sunburst)



Neck Thru construction

Back view of the DTT700MGS' 5pc Maple/ Walnut Wizard III thru-neck which increases playability, tone and sustain.



Eyal Levi
-Daáth



Jason Hook
-Five Finger Death Punch



Oli Herbert
-All That Remains



Tom G. Warrior
-Triptykon



Jack Owen
-Deicide



Muhammed Suicmez
-Necrophagist

XIPHOS

The off-the-wall shapes of the X series stand out in a crowd, but they are also excellent examples of form meeting function. With its fast neck and tremolo system, the XPT Xiphos was made for the extreme shred player. The ICT Iceman is great for hard rock, where thick tones are literally beaten out of the guitar. The DTT Destroyer is a high gain animal, cutting through the densest forests of fuzz and distortion.



XPT700XH GSF

- 5pc Wizard III Maple/Walnut neck-thru w/KTS™ TITANIUM Reinforcement
- Mahogany wing body
- Jumbo frets
- Edge III bridge
- DiMarzio® Air Norton 5™ (H) neck pu
- DiMarzio® D Activator™ (H) bridge pu
- Hardware color : Black
- Scale : 648mm/25.5"
- Color : GSF (Green Shadow Flat)



XPT700 RCM

- 5pc Wizard III Maple/Walnut neck-thru w/KTS™ TITANIUM Reinforcement
- Mahogany wing body
- Jumbo frets
- Edge III bridge
- DiMarzio® D Activator™ (H) neck pu
- DiMarzio® D Activator™ (H) bridge pu
- Hardware color : Cosmo Black
- Scale : 648mm/25.5"
- Colors : RCM (Red Chameleon)



XPT707FX GCM

- 5pc Wizard II-7 Maple/Walnut neck-thru w/KTS™ TITANIUM Reinforcement
- Mahogany wing body
- Jumbo frets
- Gibraltar Custom-7 bridge
- DiMarzio® D Activator 7™ (H) neck pu
- DiMarzio® D Activator 7™ (H) bridge pu
- Hardware color : Cosmo Black
- Scale : 648mm/25.5"
- Color : GCM (Gray Chameleon)



27 frets

The wicked XPT700XHGSF features a 27-fret 5-piece maple/walnut Wizard III thru-neck.



Gibraltar Custom Bridge

The XPT707FX features a 7-string version of the Gibraltar Custom bridge.



ICEMAN

Ibanez smashed through conventional guitar looks with the Iceman guitar, in one of rock's most unforgettable shapes. 24-fret mahogany monsters for those who want to let loose an avalanche of rock.

ICT700 BK
BK (Black)

ICT700 WH
WH (White)

XP300 IPT

- 3pc Wizard III Maple neck
- Mahogany body
- Jumbo frets
- Edge III bridge
- INF3 (H) neck pu
- INF4 (H) bridge pu
- Hardware color : Cosmo Black
- Scale : 648mm/25.5"
- Color : IPT (Iron Pewter)

XP300FX BK

- 3pc Wizard III Maple neck
- Mahogany body
- Jumbo frets
- Fixed bridge
- INF3 (H) neck pu
- INF4 (H) bridge pu
- Hardware color : Cosmo Black
- Scale : 648mm/25.5"
- Color : BK (Black)

ICT700

- 5pc Wizard III Maple/Walnut neck-thru w/KTS™ TITANIUM Reinforcement
- Mahogany wing body
- Jumbo frets
- Gibraltar Custom bridge
- DiMarzio® D Activator™ (H) neck pu
- DiMarzio® D Activator™ (H) bridge pu
- Hardware color : Black
- Scale : 648mm/25.5"
- Colors : BK (Black) WH (White)



Ihsahn



Brandon Jacobs
—Mutiny Within



Monte Money
—Escape The Fate



Ben Orum
—All Shall Perish



Devin Shidaker
—Oceano



Jesse Ketive
—Emmure



26.5 inch extra long scale
w/ whole step down tuning at factory

RGD has a 26.5" neck scale length that emits a tight sound all the way down to the lowest note without ever losing playability.

RGD

As a pioneer of heavy metal guitars, Ibanez has released 7- and 8-string models in the past, and the RGD is Ibanez's ultimate heavy metal machine. Heavy metal guitars are required to output clear sound down to the lowest note without losing playability. So we minimized extension of the neck scale to 1-inch, and original tuned pickups are mounted. Also, RGD features the special cuts on horn and body offering ultimate playability for upper fret access.



RGD2120Z ISH

- 5pc Wizard HP Maple/Walnut neck *Prestige* w/KTS™ TITANIUM Reinforcement
- Basswood body
- Jumbo frets
- Edge-Zero bridge w/ZPS3
- V7 Custom (H) neck pu
- V8 Custom (H) bridge pu
- Hardware color: Cosmo Black
- Scale: 672mm/26.5"
- Factory Tuning: 1D, 2A, 3F, 4C, 5G, 6D
- String gauge: .010/.013/.017/.026/.036/.046
- Color: ISH (Invisible Shadow)

RGD2127Z ISH

- 5pc Wizard-7 Maple/Wenge neck *Prestige* w/KTS™ TITANIUM Reinforcement
- Basswood body
- Jumbo frets
- Edge-Zero 7 bridge w/ZPS3
- V77 Custom (H) neck pu
- V87 Custom (H) bridge pu
- Hardware color: Cosmo Black
- Scale: 672mm/26.5"
- Factory Tuning: 1D, 2A, 3F, 4C, 5G, 6D, 7A
- String gauge: .010/.013/.017/.026/.036/.046/.059
- Color: ISH (Invisible Shadow)



RGD320 BK
BK (Black)



RGD320 MGS
MGS (Metallic Gray Sunburst)



RGD320 WH
WH (White)



Marc Okubo
—Veil of Maya

RGD321 BKF

- 3pc Wizard III Maple neck
- Basswood body • Jumbo frets • Gibraltar Standard bridge
- CAP-VK1 (H) neck pu
- CAP-VK2 (H) bridge pu
- Hardware color: Black • Scale: 672mm/26.5"
- Factory Tuning: 1D, 2A, 3F, 4C, 5G, 6D
- String gauge: .010/.013/.017/.026/.036/.046
- Color: BKF (Black Flat)



Gibraltar Standard Bridge

RGD Fixed Series feature the Gibraltar Standard Bridge. Ready and able for wide intonation adjustment, but rock solid in standing up to the most aggressive playing. A bridge made for crossing the great divide over to heavier rock.



RGD7321 BKF

- 3pc Wizard III Maple neck
- Basswood body • Jumbo frets • Gibraltar Standard-7 bridge
- CAP-VK17 (H) neck pu
- CAP-VK27 (H) bridge pu
- Hardware color: Black • Scale: 672mm/26.5"
- Factory Tuning: 1D, 2A, 3F, 4C, 5G, 6D, 7A
- String gauge: .010/.013/.017/.026/.036/.046/.059
- Color: BKF (Black Flat)

ZPS3 Zero Point System

The ZPS3 is the next stage of Zero Point Systems. The addition of two outer springs makes the guitar easier to tune and provides much greater tuning stability. If you prefer a full floating tremolo setup, simply remove the stop bar.

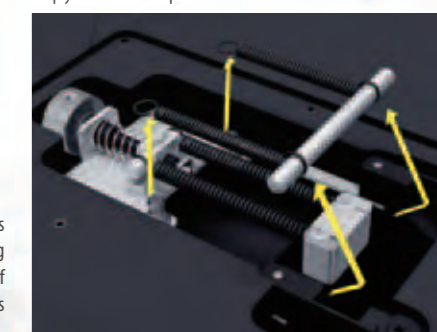

CAP VK1/VK2 custom designed pickups for down tuning

By employing the pickup magnet strength in various ways, output at the neck is perfectly balanced with high output at the bridge. These pickups are designed to increase reverberation of lower tones, making them excellent for down tuning.

Edge Zero II

Installation of the Zero Point System in the Edge Zero II makes tuning easier and faster as well as providing stable tuning for long performances, all while maintaining smooth tremolo playing. Loss of tuning is kept to a minimum even when a string breaks. For players that prefer a full floating system, simply remove the stop bar.



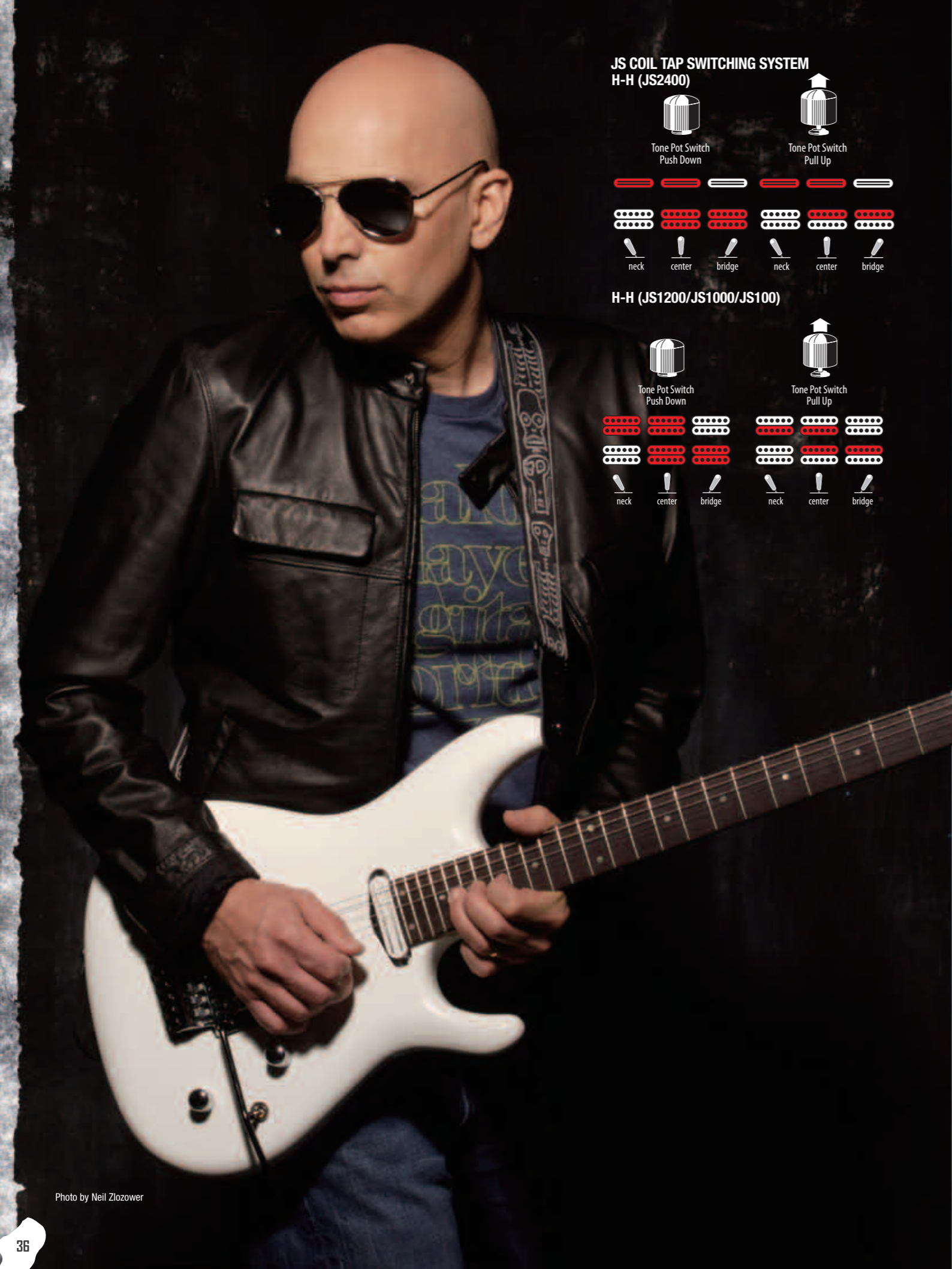

**JS COIL TAP SWITCHING SYSTEM
H-H (JS2400)**

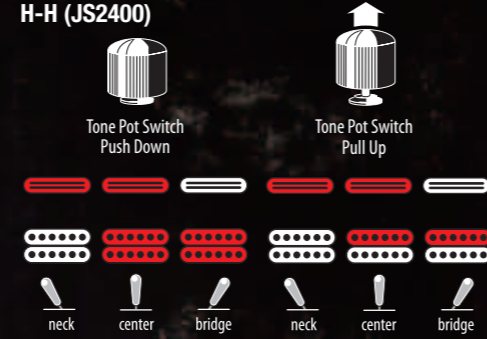

H-H (JS1200/JS1000/JS100)

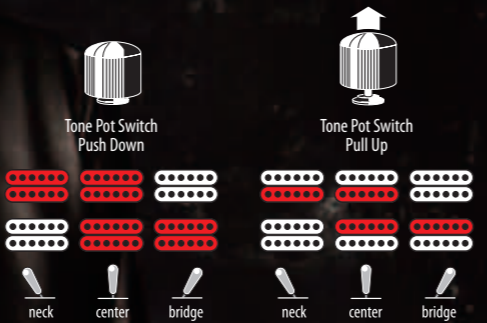

JS2400 WH

- 1pc JS Maple neck *Prestige*
- Basswood body • W/6105 frets
- Edge bridge
- DiMarzio® Pro Track™ (H) neck pu
- DiMarzio® Mo' Joe™ (H) bridge pu
- Hardware color : Chrome • Scale : 648mm/25.5"
- Color : WH (White)



JS1200 CA

- 1pc JS Maple neck *Prestige*
- Basswood body • W/6105 frets
- Edge bridge
- DiMarzio® Paf Joe™ (H) neck pu
- DiMarzio® Fred® (H) bridge pu
- Hardware color : Chrome • Scale : 648mm/25.5"
- Color : CA (Candy Apple)



JS1000 BP

- 1pc JS Maple neck *Prestige*
- Basswood body • W/6105 frets
- Edge bridge
- DiMarzio® Paf Pro® (H) neck pu
- DiMarzio® Fred® (H) bridge pu
- Hardware color : Cosmo Black • Scale : 648mm/25.5"
- Color : BP (Black Pearl)

JOE SATRIANI SIGNATURE MODELS

Maestro Joe Satriani's jaw-dropping skill on the guitar is only matched by the sheer beauty and artistry of his Signature instruments. Created in collaboration with Satch himself, these models are indeed an extension of his playing: finely nuanced yet capable of staggering heights of musicality.



JS100 BK
BK (Black)

JS100

- 1pc JS Maple neck
- Basswood body • Large frets
- Edge III bridge
- AH1 (H) neck pu
- AH2 (H) bridge pu
- Hardware color : Chrome • Scale : 648mm/25.5"
- Colors : BK (Black) TR (Transparent Red)



JS100 TR
TR (Transparent Red)

JS2400/24 Frets

The first 24-fret fingerboard JS model is Joe Satriani's newest adventure in guitars.



HERMAN LI SIGNATURE MODELS

When DragonForce guitarist Herman Li wanted a guitar that could handle his otherworldly technique and musicality, both he and Ibanez knew it would take time to get everything just right. It took three years, but they did get it right. The Ibanez E-Gen is played by Li exactly as it is, live on stage, in the studio, right off the shelf, without any modifications.



Photo by Alex Solca



EGEN18 TVF

- 5pc EGEN Maple/Walnut neck *Prestige*
- Flamed Maple top/Mahogany body
- Jumbo frets
- Edge-Zero bridge w/ZPS3
- DiMarzio® HLM (H) neck pu
- DiMarzio® HLM (S) mid pu
- DiMarzio® HLM (H) bridge pu
- Hardware color : Gold
- Scale : 648mm/25.5"
- Color : TVF (Transparent Violet Flat)



EGEN8 PLB

- 3pc Wizard III Maple neck
- Flamed Maple top/Mahogany body
- Jumbo frets
- Edge III bridge (Herman Li Special)
- V7 (H) neck pu
- S1 (S) mid pu
- V8 (H) bridge pu
- Hardware color : Gold
- Scale : 648mm/25.5"
- Color : PLB (Platinum Blonde)

SAM TOTMAN SIGNATURE MODEL

Few guitarists have the shred skills and unshakable nerve like DragonForce's Sam Totman. Sam's Signature Iceman-shaped STM2SPB is a 24-fret mahogany monster made for only the strongest of metal warriors.



STM2 SPB

- 5pc Wizard III Maple/Walnut neck-thru w/KTS™ TITANIUM Reinforcement
- Flame Maple top / Mahogany wing body
- Jumbo frets
- Edge III bridge
- DiMarzio® Evolution® (H) neck pu
- DiMarzio® Evolution® (H) bridge pu
- Hardware color : Chrome
- Scale : 648mm/25.5"
- Color : SPB (Sapphire Blue)



Photo by Paul Harries

S *Prestige*

The S Prestige is "Made in Japan" by the finest Ibanez craftsmen and from top-of-the-line components. This beautifully contoured shape, combined with the ZR-2 tremolo system, produces warm, resonant tones from a super thin mahogany body.



S5470Q WCB

- 5pc Super Wizard HP Maple/Walnut neck *Prestige* w/KTS™ TITANIUM Reinforcement
- Quilted Maple top/Mahogany body
- Jumbo frets
- ZR-2 bridge w/ZPS3
- HGD1 (H) neck pu
- ST2 (S) mid pu
- HGD2 (H) bridge pu
- Hardware color : Cosmo Black
- Scale : 648mm/25.5"
- Color : WBC (Wild Cherry Blossom)

S5470F

- 5pc Super Wizard HP Maple/Walnut neck *Prestige* w/KTS™ TITANIUM Reinforcement
- Flamed Maple top/Mahogany body
- Jumbo frets
- ZR-2 bridge w/ZPS3
- HGD1 (H) neck pu
- ST2 (S) mid pu
- HGD2 (H) bridge pu
- Hardware color : Cosmo Black
- Scale : 648mm/25.5"
- Colors : RVK (Red Viking) SPB (Sapphire Blue)

S5470 TKS

- 5pc Super Wizard HP Maple/Walnut neck *Prestige* w/KTS™ TITANIUM Reinforcement
- Mahogany body
- Jumbo frets
- ZR-2 bridge w/ZPS3
- HGD1 (H) neck pu
- ST2 (S) mid pu
- HGD2 (H) bridge pu
- Hardware color : Cosmo Black
- Scale : 648mm/25.5"
- Color : TKS (Transparent Black Sunburst)

S5470F SPB

SPB (Sapphire Blue)

S5470F RVK

RVK (Red Viking)



SUPER WIZARD HP NECK (HP=HIGH PERFORMANCE)

More comfortable neck feel, smoother neck shape, while retaining same thin profile as before – 17.0mm (at 1st fret).



ZR-2 tremolo

The ZR-2 is a revolutionary tremolo system. It plays incredibly smooth through the use of its ball bearing mechanism. This also keeps the string action constant, even during the most rigorous tremolo use. The top side features a smooth finish for total hand comfort, and the tremolo arm snaps in for quick setup.

ZPS3 Zero Point System

The ZPS3 is the next stage of Zero Point Systems. Made of lightweight Duralumin, the addition of two outer springs makes the guitar easier to tune and provides much greater tuning stability. If you prefer a full floating tremolo setup, simply remove the stop bar.

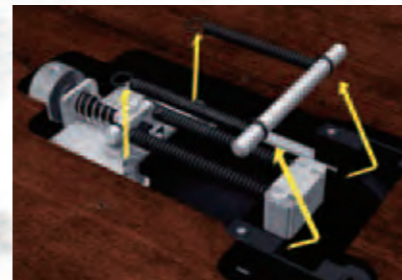

Ken Susi
–Unearth



Steve Jones
–The Faceless



The Ibanez S series first appeared in 1987. Ever since, it has changed in appearance and function to represent the cutting edge of Ibanez design. Famous for its lightweight carved mahogany body, the S can take a beating while still providing the resonance of guitars twice its size. The S series comes equipped with the ZR tremolo system, featuring a smooth ball bearing pivot for ultra-smooth arm control—same as ZR-2 tremolo system.



S770PB NTF

- 3pc Wizard III Maple neck
- Poplar Burl top/Mahogany body
- Jumbo frets
- ZR bridge w/ZPS2
- INF1 (H) neck pu
- INF51 (S) mid pu
- INF2 (H) bridge pu
- Hardware color : Cosmo Black
- Scale : 648mm/25.5"
- Color : NTF (Natural Flat)



S570DXQM TGB
TGB (Transparent Gray Burst)



S570DXQM BBB
BBB (Bright Blue Burst)



S570MQM TRB

- 3pc Wizard III Maple neck
- Quilted Maple top/Mahogany body
- Jumbo frets
- ZR bridge w/ZPS2
- INF1 (H) neck pu
- INF51 (S) mid pu
- INF2 (H) bridge pu
- Hardware color : Cosmo Black
- Scale : 648mm/25.5"
- Color : TRB (Transparent Red Burst)



S570B MG
MG (Metallic Gray)



S570B RD
RD (Red)

S570B

- 3pc Wizard III Maple neck
- Mahogany body
- Jumbo frets
- ZR bridge w/ZPS2
- INF1 (H) neck pu
- INF51 (S) mid pu
- INF2 (H) bridge pu
- Hardware color : Black
- Scale : 648mm/25.5"
- Colors : MG (Metallic Gray)
RD (Red)



S420 BBS
BBS (Blackberry Sunburst)

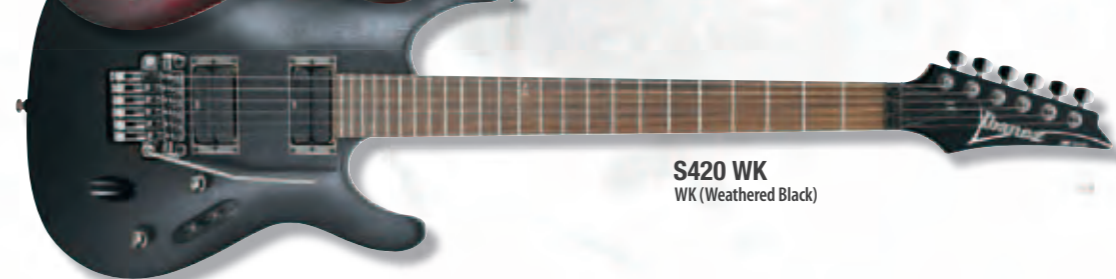

S420 WK
WK (Weathered Black)

S420

- 3pc Wizard III Maple neck
- Mahogany body
- Jumbo frets
- ZR bridge w/ZPS2
- INF1 (H) neck pu
- INF2 (H) bridge pu
- Hardware color : Cosmo Black
- Scale : 648mm/25.5"
- Colors : BBS (Blackberry Sunburst)
WK (Weathered Black)



S7420 BK

- 3pc Wizard II-7 Maple neck
- Mahogany body
- Jumbo frets
- ZR-7 bridge w/ZPS2
- AH1-7 (H) neck pu
- AH2-7 (H) bridge pu
- Hardware color : Cosmo Black
- Scale : 648mm/25.5"
- Color : BK (Black)

Luke Hoskin
—Protest The Hero

Oskar Montelius
—Sabaton
Photo by davidsfoto.se

ZPS2 Zero Point System

No friction points make the ZPS the smoothest Ibanez Back Stop ever. An additional outer pair of springs provides easier tuning and better tuning stability than the traditional floating tremolo—plus the other strings will remain in tune if a string breaks.

ZR Tremolo

The ZR tremolo with the ZPS successfully addresses the inherent drawbacks in traditional locking trem systems. Thanks to the unique ball-bearing mechanism, action and feel are incredibly smooth. The Zero Point System consistently returns the tremolo to the center position (zero point). This system offers ease of tuning, tuning stability and the ability to keep playing even after a string is broken.

S(H-H) pickup switching system H-H (5WAY)

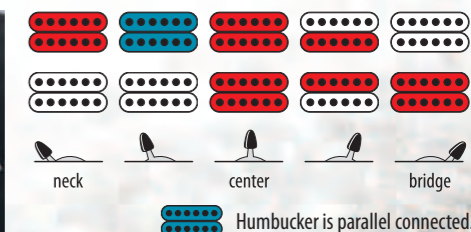



Nick Hipa
—As I Lay Dying



ARTIST ARZ

The 24-fret, two-octave fretboard of the ARZ takes it beyond the boundaries of traditional single-cutaway guitars. The smooth neck heel provides unrivaled playability, while the rigid Tight-Tune bridge and EMG® pickups make the ARZ ideal for today's heavy rockers, who demand both heavy riffing and shredding solos.

Tight-Tune Bridge/Tailpiece

Solid as a rock, the Tight-Tune bridge and tailpiece were designed to lock down securely and prevent any kind of wobble or movement. Each saddle is locked into the base plate, and the bridge is anchored by stud bolts into the body of the guitar. Furthermore, the studs are also locked onto the base plate so that the maximum vibration from the string is transferred to the body.



EMG® Pickups
The ARZ is equipped with an EMG® 60/81 pickup combination.



ARZ800 TDR
TDR (Transparent Deep Red)



ARZ800 TDB
TDB (Transparent Deep Black)



ARZ800 TDV
TDV (Transparent Deep Violet)



ARZ400 BK
BK (Black)



ARZ400 WH
WH (White)



ARZ800

- 3pc ARZ Mahogany/Maple set-in neck
- Quilted Maple top/Mahogany body
- Medium frets
- Tight-Tune bridge
- Tight-Tune tailpiece
- EMG® 60 (H) neck pu
- EMG® 81 (H) bridge pu
- Hardware color : Cosmo Black
- Scale : 635mm/25"
- Colors : TDR (Transparent Deep Red)
TDB (Transparent Deep Black)
TDV (Transparent Deep Violet)



Deep Cutaway at horn
The scoop cut on the back of the neck allows for smooth playing at higher frets.



24 Frets
The ARZ is designed with 24 frets for more freedom in performance.

ARZ400

- ARZ Mahogany set-in neck
- Maple top/Mahogany body
- Medium frets
- Gibraltar III bridge
- Quik Change III tailpiece
- EMG® H4A (H) neck pu
- EMG® H4 (H) bridge pu
- Hardware color : Chrome
- Scale : 635mm/25"
- Colors : BK (Black) WH (White)

ARZ307 BK

- 3pc ARZ Mahogany/Maple set-in neck
- Maple top/Mahogany body
- Medium frets
- Full Tune III-7 bridge
- AH3-7 (H) neck pu
- AH4-7 (H) bridge pu
- Hardware color : Chrome
- Scale : 635mm/25"
- Color : BK (Black)



Sean Kipe
—Course of Nature



Matt Roberts
—3 Doors Down

ART ARTIST

Simple and effective, the ART is a classic single-cutaway guitar that was built for modern metal. The mahogany body is capable of producing the warm tones of yesterday, while the active low-impedance pickups can handle massive volume levels with very little noise.



ART700EQM BB
BB (Blackberry)



ART700EQM TK
TK (Transparent Black)

ART700EQM

- ART Mahogany set-in neck
- Quilted Maple top/Mahogany body
- Medium frets
- Tight-Tune Bridge
- Tight-Tune tailpiece
- EMG® 60 (H) neck pu
- EMG® 81 (H) bridge pu
- Hardware color : Cosmo Black
- Scale : 628mm/24.75"
- Colors : BB (Blackberry) TK (Transparent Black)



ART500E WH
WH (White)

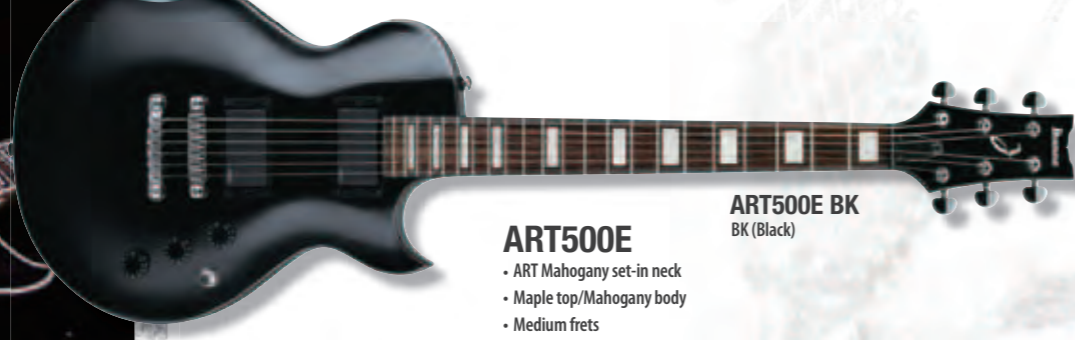

ART500E BK
BK (Black)

ART500E

- ART Mahogany set-in neck
- Maple top/Mahogany body
- Medium frets
- Gibraltar III bridge
- Quik Change III tailpiece
- EMG® 60 (H) neck pu
- EMG® 81 (H) bridge pu
- Hardware color : Cosmo Black
- Scale : 628mm/24.75"
- Colors : BK (Black) WH (White)



ART320 BB
BB (Blackberry)



ART320 BLS
BLS (Blue Sunburst)



ARX320 TCR
TCR (Transparent Cherry)



ARX320 TKS
TKS (Transparent Black Sunburst)

ART320

- ART Mahogany set-in neck
- Flamed Maple top/Mahogany body
- Medium frets
- Gibraltar III bridge
- Quik Change III tailpiece
- LZ1-N (H) neck pu
- LZ1-B (H) bridge pu
- Hardware color : Cosmo Black
- Scale : 628mm/24.75"
- Colors : BB (Blackberry) BLS (Blue Sunburst)

ARX320

- ARX Mahogany set-in neck
- Quilted Maple top/Mahogany body
- Medium frets
- Gibraltar III bridge
- Quik Change III tailpiece
- ACH1-S (H) neck pu
- ACH2-S (H) bridge pu
- Hardware color : Chrome
- Scale : 628mm/24.75"
- Colors : TCR (Transparent Cherry) TKS (Transparent Black Sunburst)



**Gibraltar III Bridge/
Quik Change III Tailpiece**
With the addition of the Quik Change III tailpiece, string changes are a snap on the Gibraltar III bridge. Its simple rigid design is perfect for harder playing styles.

ARTIST ART



ART100 BK
BK (Black)



ART100 GD
GD (Gold)



ART100 VLS
VLS (Violin Sunburst)



ART100 WH
WH (White)



ART100 TCR
TCR (Transparent Cherry)



ART100

- ART Mahogany set-in neck
- Maple top/Mahogany body
- Medium frets
- Gibraltar III bridge
- Quik Change III tailpiece
- ACH1-S (H) neck pu
- ACH2-S (H) bridge pu
- Hardware color : Chrome
- Scale : 628mm/24.75"
- Colors : BK (Black) GD (Gold) VLS (Violin Sunburst) WH (White) TCR (Transparent Cherry)



Gibraltar III Bridge/ Quik Change III Tailpiece

With the addition of the Quik Change III tailpiece, string changes are a snap on the Gibraltar III bridge. Its simple rigid design is perfect for harder playing styles.

ART100 BKL

- Left-Handed
- ART Mahogany set-in neck
- Maple top/Mahogany body
- Medium frets
- Gibraltar III bridge
- Quik Change III tailpiece
- ACH1-S (H) neck pu
- ACH2-S (H) bridge pu
- Hardware color : Chrome
- Scale : 628mm/24.75"
- Color : BK (Black)

GART



GART50FA TRB
TRB (Transparent Red Burst)



GART50FA TKS
TKS (Transparent Black Sunburst)



GART50QA TBB
TBB (Transparent Blue Burst)



GART50QA TRB
TRB (Transparent Red Burst)



GART50QA TKS
TKS (Transparent Black Sunburst)



GART50FA

- GART Maple neck
- Flame Maple Art Grain top/Basswood body
- Medium frets
- Fixed bridge
- PSND1 (H) neck pu
- PSND2 (H) bridge pu
- Hardware color : Chrome
- Scale : 628mm/24.75"
- Colors : TRB (Transparent Red Burst) TKS (Transparent Black Sunburst)

GART50QA

- GART Maple neck
- Quilted Maple Art Grain top/Basswood body
- Medium frets
- Fixed bridge
- PSND1 (H) neck pu
- PSND2 (H) bridge pu
- Hardware color : Chrome
- Scale : 628mm/24.75"
- Colors : TBB (Transparent Blue Burst) TRB (Transparent Red Burst) TKS (Transparent Black Sunburst)

GART50QA TRBL

- Left-Handed
- GART Maple neck
- Quilted Maple Art Grain top/Basswood body
- Medium frets
- Fixed bridge
- PSND1 (H) neck pu
- PSND2 (H) bridge pu
- Hardware color : Chrome
- Scale : 628mm/24.75"
- Color : TRB (Transparent Red Burst)

SV *Prestige*

The S series has long been admired for its design, but some players prefer the simplicity of a non-locking tremolo. The SV was created to satisfy the professional player who wants a more versatile solution. The SynchroniZR non-locking tremolo uses the same smooth ball bearing mechanisms that have made the ZR bridge so popular. The SV also comes equipped with the True-Duo pickup system for superior tonal variety from the single coil and humbucker universe.

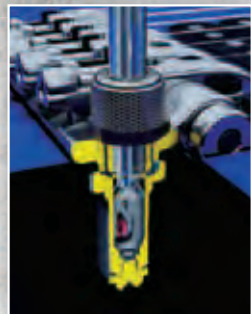

SynchroniZR Tremolo

The SynchroniZR provides all the innovations of the ZR tremolo in a non-locking design. The one-piece saddle construction minimizes unnecessary wobble and loss of string vibration, and the ultra-light Duralumin tremolo arm keeps the bridge stable while playing. The same intonation and adjustment features of the ZR-2 make this a topnotch choice for any kind of player.

H-S-H (w/True-Duo Blast)

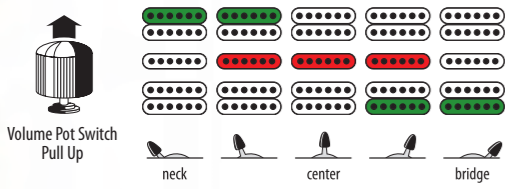
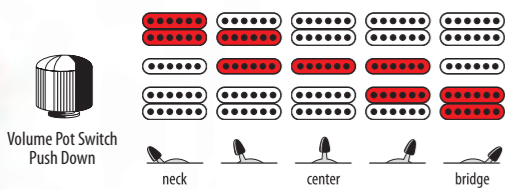

Stacked Single Coil

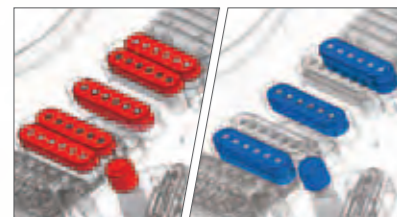

TRUE-DUO™ SINGLE COIL/HUMBUCKER SWITCHING SYSTEM

There have been lots of attempts and claims, but the new True-Duo™ is the genuine article – the first system that really provides both genuine glassy single-coil tones and rich, beefy humbucking tones in one pickup. After a lot of research and experimentation, Ibanez's musician/engineers came up with an ingenious triple coil pickup that finally does the job.

True-Duo™ pickup switching system

The SA260FM features two single coil AXIS pickups in neck and middle positions and a True Duo Bucker in the bridge for an amazing tonal range.



Josh Rand
–Stone Sour

Photo by Michael Johansson



Larry Mitchell



Rob Daniels

Photo by Roland Woodworth



SV5470F NBL
NBL (Natural Blue)



SV5470F DSB
DSB (Dark Sunset Burst)

SV5470F

- 5pc Wizard HP Maple/Walnut neck *Prestige*
- Flamed Maple top/Mahogany body
- Jumbo frets
- SynchroniZR bridge w/ZPS-FX
- TDB2 (H) neck pu
- ST2 (S) mid pu
- TDB3 (H) bridge pu
- Hardware Color : Cosmo Black
- Scale : 648mm/25.5"
- Colors : NBL (Natural Blue)
DSB (Dark Sunset Burst)

SA

You want versatility? The SA adapts to any genre of music for clean rhythm, crunchy blues or even hard-driving riffs and solos. It also offers a variety of looks, such as metal-like solid color or traditional wooden finishes. The SA also makes use of the same True-Duo pickup system available on the SV models and the abundant resonance of the SAT-Pro tremolo.



SA260FM BBS

- 3pc SA Maple neck
- Flamed Maple top/Mahogany body
- Medium frets
- SAT Pro II bridge
- AHS1 (S) neck pu
- AHS2 (S) mid pu
- True Duo Bucker (H) bridge pu
- Hardware color : Chrome
- Scale : 648mm/25.5"
- Color : BBS (Blackberry Sunburst)

GSA



GSA60 BKN
BKN (Black Night)

GSA60

- GSA Maple neck
- Basswood body
- Medium frets
- SAT10 bridge
- PSNDS (S) neck pu
- PSNDS (S) mid pu
- PSND2 (H) bridge pu
- Hardware color : Chrome
- Scale : 648mm/25.5"
- Colors : BKN (Black Night)
JB (Jewel Blue)



GSA60 JB
JB (Jewel Blue)



Gizz Butt
—The More I See



Mike Reynolds
—For Today
Photo by Shane Monahan

FR

With a simple and uncompromising design, the FR is a chameleon when it comes to musical genres. The ash body brings more punch to the midrange tones, while the Tight-End bridge provides maximum string vibration and playing comfort.



FR1620 BK
BK (Black)

FR1620 RDO
RDO (Red Optimus)

- FR1620**
- 5pc Wizard HP Maple/Walnut neck *Prestige*
 - Ash body
 - Jumbo frets
 - Tight-End bridge
 - CAP-CCR1 (H) neck pu
 - CAP-CCR2 (H) bridge pu
 - Hardware color : Chrome
 - Scale : 648mm/25.5"
 - Colors : BK (Black)
RDO (Red Optimus)



Tight-End Bridge
The Tight-End bridge integrates every aspect of the bridge design in rigidity and accuracy. Saddles are firmly locked onto the base plate for maximum string vibration, and remain perfectly linear during intonation adjustment for the most accurate set up. The saddle height can be adjusted individually by one screw. Also, the top side of the bridge is smooth finished. So if you play hard, the Tight-End bridge will forgive you and your hands.

THE MARS VOLTA

OMAR RODRIGUEZ LOPEZ SIGNATURE MODEL

Created with traditional looks in mind, this guitar had to excel in just about any situation to work in The Mars Volta. If anyone knows how to push a guitar to its limits, it's Omar Rodriguez-Lopez. The white finish ORM1WH passes every test.

- ORM1 WH**
- 3pc ORM Mahogany neck
 - Mahogany body
 - Medium frets
 - Gibraltar III bridge
 - ACH-BL (H) bridge pu
 - Hardware color : Chrome
 - Scale : 610mm/24.0"
 - Color : WH (White)



NDM2 BK

- 3pc NDM Maple neck
- Basswood body
- Large frets
- Fixed bridge
- INF1 (H) neck pu
- INF51 (S) mid pu
- INF2 (H) bridge pu
- Hardware color : Chrome
- Scale : 648mm/25.5"
- Color : BK (Black)

THE OFFSPRING NOODLES SIGNATURE MODEL

Born from punk rock attitude but built for all things aggressive. The NDM's mirrored skull Offspring emblem says it all – Flaming Death or Glory! Noodles' Signature NDM2BK is an all-purpose rock axe that can fit into any mix.

JUMPSTART

When we say "Everything you need to get out and gig," we mean everything — amp, axe, accessories. All it takes is you and your desire to make your dreams real to get out of the audience and up on stage where you belong.



GART30B BKN

IJX25-JumpStart-

- Maple GART neck
- Basswood body
- Medium frets
- Fixed bridge
- PSND1 neck pu
- PSND2 bridge pu
- BKN (Black Night)



IJX20-JumpStart-



IJX20 -JumpStart-

- Maple GRX neck
- Basswood body
- Medium frets
- FAT 6 bridge
- PSND1 neck pu
- PSND2 bridge pu
- BKN (Black Night)
- RD (Red)

GRX20Z RD

GRX20Z BKN

IJX20 & IJX25 ACCESSORIES

- 10 Watt amp
- Electronic Tuner
- Gig Bag
- Guitar Strap
- Picks and Cable



IJX20 & IJX40 ACCESSORIES

- 15 Watt amp
- Head phones
- Electronic Tuner
- Gig Bag
- Guitar Strap
- Picks and Cable
- Chord Chart Poster
- Accessory Pouch



GRG121EX BKN

IJX121 -JumpStart-

- Maple GRG neck
- Basswood body
- Medium frets
- Fixed bridge
- STDH1 neck pu
- STDH2 bridge pu
- BKN (Black Night)

IJX40 -JumpStart-

- Maple GRX neck
- Basswood body
- Medium frets
- FAT 6 bridge
- PSND-S neck pu
- PSND-S mid pu
- PSND2 bridge pu
- MR (Metallic Red)
- BKN (Black Night)
- JB (Jewel Blue)



GRX40Z MR

GRX40Z JB

GRX40Z BKN



*Contents of packages are subject to change without notice.

 Siméon Koch Eluveitie	 Kirk Kolaïtis Diecast	 Jukka Koskinen Wintersun, Norther, Amberian Dawn	 Steinar Krokmo Pagan's Mind	 Tomy Laisto Hateform, Mors Principium Est	 John Lamacchia Candiria, A Family Plot	 Lanvall Edenbridge
 Fredrik Larsson Hammerfall	 Parker Lauzon Evans Blue	 Alex Lee Bonded by Blood	 Mike Lerner Behold... The Arctopus	 Petri Lindroos Ensiferum	 Justin Lowe After The Burial	 Antoine Lussier Ion Dissonance
 Jari Mäenpää Wintersun	 Christofer Malmström Darkane	 David Manley Jill Scott, Philosophik., Alo Brasil	 Teemu Mäntysaari Wintersun	 Andreas Mäser The Sorrow	 James Mclroy Cradle Of Filth, Order Of Apollyon	 Patrick Meadows Gwen Stacy
 Mark Mitchell Throwdown	 Atsushi Miyamoto Opus Dai	 Christian Münzner Obscura, Spawn of Possession	 Mike Murphy Haste The Day	 Marcel Neumann We Butter the Bread with Butter	 Joe Nicholson Rolo Tomassi	 Kristian Niemann Demonoid
 Johan Niemann Tiamat, Evergrey, Demonoid	 Per Nilsson Scar Symmetry	 Daniel Oberländer War from a Harlot's Mouth	 OX Lordi	 Marko Paasikoski Sonata Arctica	 Rob Patterson Filter	 Maximilian Pauly We Butter the Bread with Butter
 Joe Payne Divine Heresy	 Joe Pitter Evans Blue	 Matthew Pugh The Eyes of a Traitor	 Aaron Richert Timelord	 Patrick Rondat Patrick Rondat, Elegy	 Scott Root Dirtfëdd	 Tim Roth Into Eternity
 Henri Sattler God Dethroned	 Oliver Schmidt Letzte Instanz	 Caleb Schneider Bad Acid Trip	 Jake Scott Salt the Wound	 Arthur Seay House of Broken Promises	 Dominik Sebastian Edenbridge	 Roni Seppänen Tracedawn
 Justin Shekoski Saosin	 David Shoaf Killwhiteydead, The Demonstration	 Christoph Siemons Krypteria	 Roger Sjunnesson Sonic Syndicate	 Terji Skibenaes Týr	 Ken Sorceron Aborted, Abigail Williams	 Waldemar Sorychta Enemy of the Sun
 Nita Strauss Kill Slowly	 Vince Stropki Salt the Wound	 Frank Stumvoll Krypteria	 Jason Suecof	 Marcus Sunesson Engel	 Gunnar H. Thomsen Týr	 Markus Toivonen Ensiferum
 Alex Torres Alesana	 Theo van Eckelen Hail of Bullets	 Angel Vivaldi	 Paul Waudby The Eyes of a Traitor	 Brian "Head" Welch	 Jussi Wickström Turisas	 Henke Zinger God Dethroned



FULL AND SEMI ACOUSTIC ELECTRIC GUITARS



GEORGE BENSON SIGNATURE MODELS

George Benson's taste, tone, bluesy phrasing, and incomparable sense of swing has ensured his place in the history of jazz guitar. Ibanez is extremely proud of our long and fruitful relationship, now celebrating over 30 years of collaboration. The GB models are some of the finest jazz guitars on the market today.



GB10 BS
BS (Brown Sunburst)

GB10

- 3pc GB Maple set-in neck *Prestige*
- Spruce top/Maple back & sides
- Medium frets
- Ebony bridge • GB10 tailpiece
- GB special (H) neck pu
- GB special (H) bridge pu
- Hardware color : Gold
- Scale : 628mm/24.75"
- Depth : 65mm at tail
- Colors : BS (Brown Sunburst) NT (Natural)



GB10 NT
NT (Natural)



GB200 BS

- 3pc GB Mahogany/Maple set-in neck *Prestige*
- Spruce top/Flamed Maple back & sides
- Medium frets
- Ebony bridge
- GB200 tailpiece
- Super 58 (H) neck pu
- Super 58 (H) bridge pu
- Hardware color : Gold
- Scale : 628mm/24.75"
- Depth : 80mm at tail
- Color : BS (Brown Sunburst)



PAT METHENY SIGNATURE MODELS

An Ibanez Signature artist since 1996, Pat's adventurous forays into jazz, pop, folk, and Latin music have enthralled audiences all over the world. At the core of these journeys are, of course, Pat's sumptuous guitar playing and his Ibanez Signature instruments.



PM120 NT
NT (Natural)

PM120

- PM Mahogany set-in neck *Prestige*
- Maple top/back/sides • Medium frets
- Gotoh® 103B bridge • PM tailpiece
- Silent 58 (H) neck pu • Silent 58 (H) bridge pu
- Hardware color : Gold • Scale : 628mm/24.75" • Depth : 50mm at tail
- Colors : BK (Black) NT (Natural)



PM120 BK
BK (Black)



PM35 NT

- 5pc PM Maple/Walnut set-in neck
- Maple top/back/sides • Medium frets
- ART-1 bridge • KT30 tailpiece
- Super 58 Custom (H) neck pu
- Hardware color : Gold • Scale : 628mm/24.75" • Depth : 70mm at tail
- Color : NT (Natural)



JOHN SCOFIELD SIGNATURE MODEL

Guitarist John Scofield has blazed a fearless trail, moving effortlessly in and out of bop, fusion, rock, funk, blues, and soul. Since becoming an Ibanez Signature artist in 2001, John's trusted JSM100 has been at the ready, waiting for the next adventurous musical turn in the road.



JSM100 VT

- JSM Mahogany set-in neck *Prestige*
- Flamed Maple top/back/sides • Jumbo frets
- Gotoh® 510BN bridge
- Gotoh® GE101A tailpiece
- Super 58 (H) neck pu
- Super 58 (H) bridge pu
- Hardware color : Gold • Scale : 628mm/24.75" • Depth : 43mm at tail
- Color : VT (Vintage Sunburst)

Photo by Nick Suttie

ARTCORE CUSTOM

The Artcore Custom is the flagship of the Artcore series, featuring beautiful maple bodies and maple/walnut set-in neck construction, producing warm yet punchy tone. Wood control knobs and matching pickguard enhance the exquisite appearance of the Artcore Custom.



Custom Fret Edge Treatment



AF125 AMB

- 5pc Artcore Maple/Walnut set-in neck
- Quilted Maple top/back/sides
- Medium frets
- ART-1 bridge
- VT04 Custom tailpiece
- Super 58 Custom (H) neck pu
- Super 58 Custom (H) bridge pu
- Hardware color : Gold
- Scale : 628mm/24.75"
- Depth : 70mm at tail
- Color : AMB (Amber Burst)



AF105 NT

- 5pc Artcore Maple/Walnut set-in neck
- Flamed Maple top/back/sides
- Medium frets
- ART-1 bridge
- VT04 Custom tailpiece
- Super 58 Custom (H) neck pu
- Super 58 Custom (H) bridge pu
- Hardware color : Gold
- Scale : 628mm/24.75"
- Depth : 70mm at tail
- Color : NT (Natural)



AS103 VB

- 5pc Artcore Maple/Walnut set-in neck
- Flamed Maple top/back/sides
- Medium frets
- ART-1 bridge
- Quik Change III tailpiece
- Super 58 Custom (H) neck pu
- Super 58 Custom (H) bridge pu
- Hardware color : Gold
- Scale : 628mm/24.75"
- Depth : 43mm at tail
- Color : VB (Vintage Burst)

AK

Jazz and blues history is filled with the warm tones of large hollow body guitars. The AK escapes from the bright sound of maple tops and metal bridges, replacing them with a spruce top and an all-wood bridge.



AK95 DVS

- 3pc Artcore Mahogany/Maple set-in neck
- Spruce top / Flamed maple back & sides
- Medium frets
- ART-W wooden bridge
- VT100DX tailpiece
- ACH1 (H) neck pu
- ACH2 (H) bridge pu
- Hardware color : Gold
- Scale : 628mm/24.75"
- Depth : 70mm at tail
- Color : DVS (Dark Violin Sunburst)



AK80 BS

- 3pc Artcore Mahogany/Maple set-in neck
- Spruce top / Flamed maple back & sides
- Medium frets
- ART-W wooden bridge
- VT60 tailpiece
- ACH1 (H) neck pu
- ACH2 (H) bridge pu
- Hardware color : Chrome
- Scale : 628mm/24.75"
- Depth : 70mm at tail
- Color : BS (Brown Sunburst)

20 frets and warmer neck pickup tone

The traditional 20-fret fingerboard offers just the right placement of the neck pickup, for warmer tone.



U-Nam



Ryan Helm
—Demon Hunter

Photo by Evan Duly

AF/AFS

The AF is the most traditional of the Artcore series. The traditional full-hollow construction means there are no sound blocks in the body. Producing rich and complex tones, the AF is the guitar for the purist in all of us. Pushing traditional concepts one step further, the Ibanez AFS has the same shape and full-hollow body of the AF. For increased comfort and more midrange punch, the body depth is one inch thinner. An Ibanez Vintage Vibrato is also mounted on the body with roller saddles, eliminating the tuning problems of traditional systems.



AF95 VLS

- 3pc Artcore Mahogany/Maple set-in neck
- Flamed Maple top/back/sides
- Medium frets
- ART-1 bridge • VT100DX tailpiece
- ACH1 (H) neck pu
- ACH2 (H) bridge pu
- Hardware color : Gold
- Scale : 628mm/24.75"
- Depth : 70mm at tail
- Color : VLS (Violin Sunburst)

AF75

- Artcore Mahogany set-in neck
- Maple top/back/sides • Medium frets
- ART-1 bridge • VT60 tailpiece
- ACH1 (H) neck pu
- ACH2 (H) bridge pu
- Hardware color : Chrome
- Scale : 628mm/24.75"
- Depth : 70mm at tail
- Colors : BS (Brown Sunburst)
TRS (Transparent Red Sunburst)

AF75D TOR

- Artcore Mahogany set-in neck
- Maple top/back/sides
- Medium frets
- ART-1 bridge • VT60 tailpiece
- ACH1 (H) neck pu
- ACH2 (H) bridge pu
- Hardware color : Chrome
- Scale : 628mm/24.75"
- Depth : 70mm at tail
- Color : TOR (Transparent Orange)

VBF70 Vintage Vibrato*

This old school vibrato adds country and rockabilly nuances to the rich tone of a full-hollow guitar, but the included roller saddles eliminate "old school" tuning problems.
*VBF70 Vintage Vibrato design licensed by Fred W. Gretsch Enterprises, Ltd. in the U.S.



AFS body thickness

The AFS body also features full-hollow construction, offering more midrange punch. Smoky jazz, retro twang, rocking blues and swinging country are all within the world of AFS.



AF75TDG BK
BK (Black)



AF75TDG IV
IV (Ivory)

AF75TDG

- Artcore Mahogany set-in neck
- Maple top/back/sides
- Medium frets
- ART-2 Roller bridge
- VBF70 vibrato
- ACH1 (H) neck pu
- ACH2 (H) bridge pu
- Hardware color : Gold
- Scale : 628mm/24.75"
- Depth : 70mm at tail
- Colors : BK (Black) IV (Ivory)



AFS80T RGM
RGM (Roadster Green Metallic)



AFS80T ROM
ROM (Roadster Orange Metallic)

AFS80T

- 3pc Artcore Mahogany/Maple set-in neck
- Maple top/back/sides
- Medium frets
- ART-2 Roller bridge
- VBF70 vibrato
- ACH1 (H) neck pu
- ACH2 (H) bridge pu
- Hardware color : Chrome
- Scale : 628mm/24.75"
- Depth : 43mm at tail
- Colors : RGM (Roadster Green Metallic)
ROM (Roadster Orange Metallic)



AFS75T TRD

- Artcore Mahogany set-in neck
- Maple top/back/sides
- Medium frets
- ART-2 Roller bridge
- VBF70 vibrato
- ACH1 (H) neck pu
- ACH2 (H) bridge pu
- Hardware color : Chrome
- Scale : 628mm/24.75"
- Depth : 43mm at tail
- Color : TRD (Transparent Red)

AG

The AG has a slightly smaller body width than the more traditional AF dimensions. However, the same depth and true full-hollow body construction make for a big standout sound.



Artcore Mini Humbucking Pickups

Matching the AGR's compact body, the Artcore Mini Humbucking pickups output full, yet warm and tight sound for various occasions.

Sure Grip Knobs

Designed for precise control of knobs with nonslip functionality, along with smooth and classic looks.



AG95 DBS

- 3pc Artcore Mahogany/Maple set-in neck
- Figured Bubinga top/back/sides
- Medium frets
- ART-1 bridge
- VT100DX tailpiece
- ACH1 (H) neck pu
- ACH2 (H) bridge pu
- Hardware color: Gold
- Scale: 628mm/24.75"
- Depth: 70mm at tail
- Color: DBS (Dark Brown Sunburst)



AG75 BS
BS (Brown Sunburst)

AG75

- Artcore Mahogany set-in neck
- Maple top/back/sides
- Medium frets
- ART-1 bridge
- VT60 tailpiece
- ACH1 (H) neck pu
- ACH2 (H) bridge pu
- Hardware color: Chrome
- Scale: 628mm/24.75"
- Depth: 70mm at tail
- Colors: BS (Brown Sunburst)
TBR (Transparent Brown)



AG75 TBR
TBR (Transparent Brown)

AGR

The newest addition to the Artcore series, the AGR has a shallower body than the AG series, but still retains the big-sounding full-hollow body. The shiny look of the body makes the AGR perfect for dynamic stage performance.



AGR73T TSW

- Artcore Mahogany set-in neck
- Maple top/back/sides • Medium frets
- ART-1 bridge • VBF70 vibrato
- ACH3-M (H) neck pu
- ACH4-M (H) bridge pu
- Hardware color: Gold
- Scale: 628mm/24.75"
- Depth: 50mm at tail
- Color: TSW (Twinkle Snow)

AGR70 BK

- Artcore Mahogany set-in neck
- Maple top/back/sides • Medium frets
- ART-1 bridge • VT60 tailpiece
- ACH1-M (H) neck pu
- ACH2-M (H) bridge pu
- Hardware color: Chrome
- Scale: 628mm/24.75"
- Depth: 50mm at tail
- Color: BK (Black)



Eric Krasno
-Soulive



Chris Camozzi
-Michael Bolton

Justin Furstenfeld
—Blue October



Andy Jackson
—Terrible Things



AS93 BLS

- 3pc Artcore Mahogany/Maple set-in neck
- Flamed Maple top/back/sides
- Medium frets
- ART-1 bridge
- Quik Change III tailpiece
- ACH1 (H) neck pu
- ACH2 (H) bridge pu
- Hardware color : Gold
- Scale : 628mm/24.75"
- Depth : 43mm at tail
- Color : BLS (Blue Sunburst)



AS73 IV
IV (Ivory)



AS73 BS
BS (Brown Sunburst)



AS73 TCR
TCR (Transparent Cherry)



AS73B BKF

- Artcore Mahogany set-in neck
- Maple top/back/sides
- Medium frets
- ART-1 bridge
- Quik Change III tailpiece
- ACH1-S (H) neck pu
- ACH2-S (H) bridge pu
- Hardware color : Chrome
- Scale : 628mm/24.75"
- Depth : 43mm at tail
- Color : BKF (Black Flat)



AS73 TCRL

- Left-Handed
- Artcore Mahogany set-in neck
- Maple top/back/sides
- Medium frets
- ART-1 bridge
- Quik Change III tailpiece
- ACH1 (H) neck pu
- ACH2 (H) bridge pu
- Hardware color : Chrome
- Scale : 628mm/24.75"
- Depth : 43mm at tail
- Color : TCR (Transparent Cherry)

AS73

- Artcore Mahogany set-in neck
- Maple top/back/sides
- Medium frets
- ART-1 bridge
- Quik Change III tailpiece
- ACH1 (H) neck pu
- ACH2 (H) bridge pu
- Hardware color : Chrome
- Scale : 628mm/24.75"
- Depth : 43mm at tail
- Colors : IV (Ivory) BS (Brown Sunburst) TCR (Transparent Cherry)

AM

Don't be fooled by its smaller size – the AM model has all the power, presence and features of its larger cousins. It's perfect for smaller players or anyone else who wants the traditional semi-acoustic elements but not the traditional size.

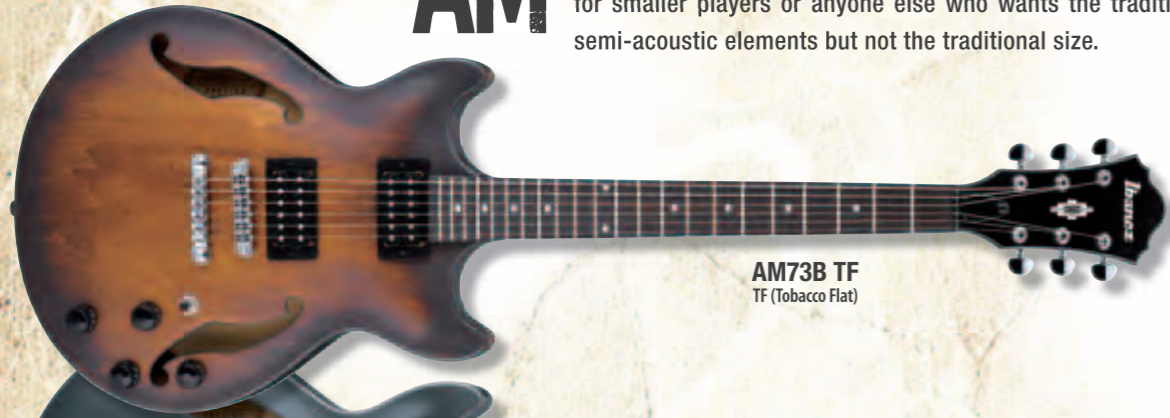

AM73B TF
TF (Tobacco Flat)



AM73B BKF
BKF (Black Flat)

AM73B

- Artcore Mahogany set-in neck
- Maple top/back/sides • Medium frets
- ART-1 bridge • Quik Change III tailpiece
- ACH1-S (H) neck pu
- ACH2-S (H) bridge pu
- Hardware color : Chrome
- Scale : 628mm/24.75" • Depth : 43mm at tail
- Colors : TF (Tobacco Flat) BKF (Black Flat)

AMF

With semi-hollow, flat-top bodies and even chicken head knobs, AMF models have a quintessential 60's look and feel. Ibanez designed the AMF with the aim of bringing the traditional tone and look of hollow body guitars into more modern musical realms.



AMF73 TF
TF (Tobacco Flat)



AMF73 BK
BK (Black)

AMF73

- Artcore Mahogany set-in neck
- Maple top/back/sides
- Medium frets • ART-1 bridge
- ACH1-S (H) neck pu
- ACH2-S (H) bridge pu
- Hardware color : Chrome
- Scale : 628mm/24.75" • Depth : 43mm at tail
- Colors : TF (Tobacco Flat) BK (Black)



Flat-top compact semi-hollow body

AMF73 BK and AMF73 TF models shout a 60's look and feel, with semi-hollow, flat-top bodies and even chicken head knobs!

ELECTRIC BASSES

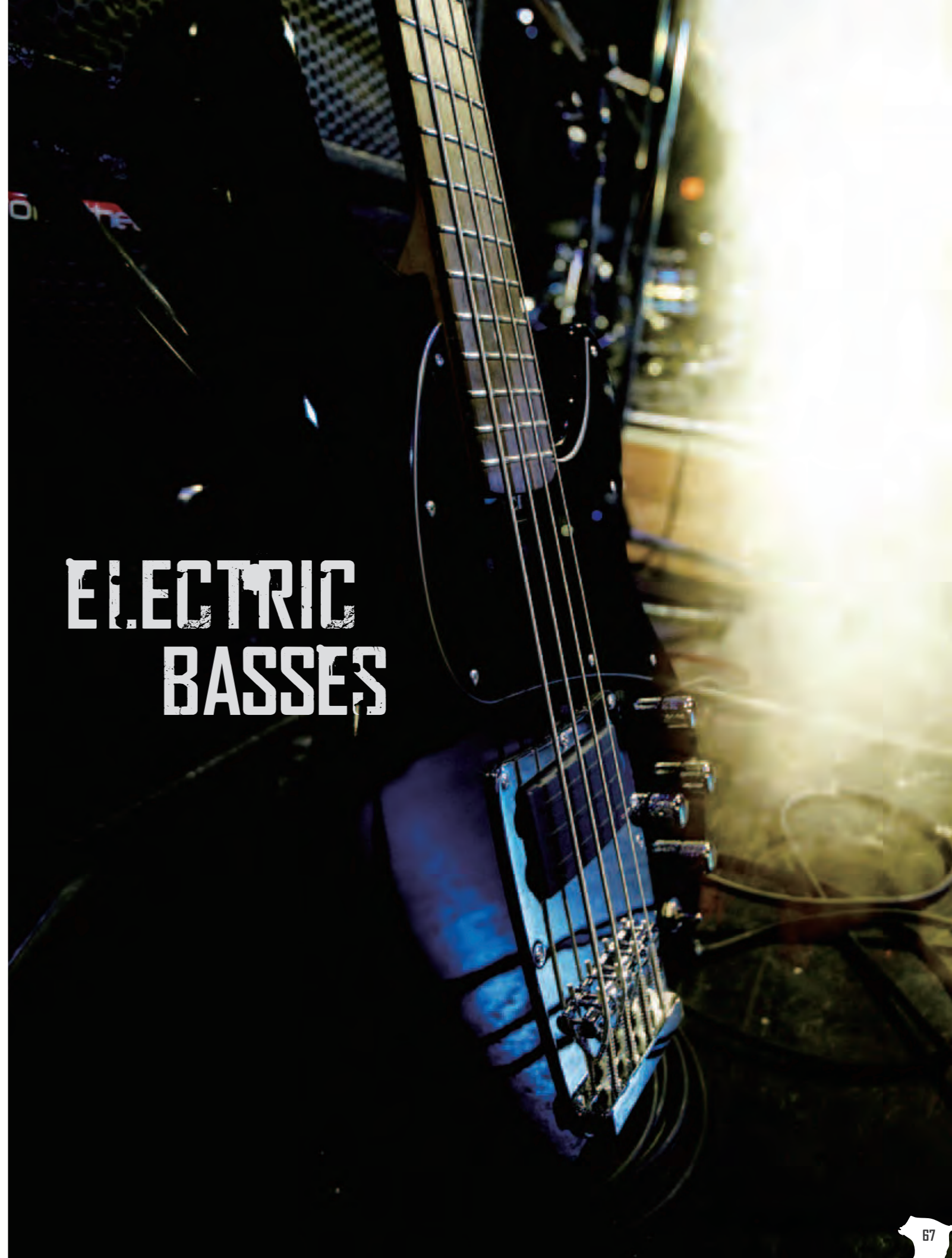



SR PREMIUM

The Ibanez SR bass is well known for its playing comfort and flexibility like no others. The SR Premium has the classic slim neck and comes equipped with the high profile MR4 Mono-Rail bridge. In addition to those traditional features of SR, its select wood materials and the combination of Nordstrand™ pickups and EQB-IIISC—specially customized EQ for the SR Premium—deliver you top performance.



EQB-IIISC

The EQB-IIISC is a customized 3-band EQ made especially for Nordstrand™ pickups. The EQ bypass switch makes it possible to use Nordstrand™ pickups as passive pickups. This gives players a wide variety of sound possibilities through mixing the direct sound of passive pickups with the characteristic sound of active pickups.



Nordstrand™ Pickups

Nordstrand™ pickups provide the clear sound characteristic of single coil pickups, while the large body gives players a powerful and aggressive tone.

MR4 Mono-Rail Bridge

The Mono-Rail Bridge is the ultimate in string isolation for bass. Each saddle is independently and securely locked down to the body for maximum vibration transfer and no interference. One screw controls the height of each saddle for easy adjustment.



Premium Fret Edge Treatment

The premium fret edges are processed to be specially rounded for smooth play and comfortable neck grip.



SR1400E VNF

- 5pc Atlas-4 Wenge/Bubinga neck w/KTS™ TITANIUM Reinforcement
- BLACK TUSQ XL® NUT
- Figured Maple Top/Mahogany Body
- Medium frets
- MR-4 bridge (19.0mm string spacing)
- Nordstrand™ Big Single 4 neck pu
- Nordstrand™ Big Single 4 bridge pu
- EQB-IIISC 3-band eq
- Elixir® strings
- Hardware color : Gold
- Scale : 864mm/34"
- Colors : VNF (Vintage Natural Flat)

SR1405E VNF

- 5pc Atlas-5 Wenge/Bubinga neck w/KTS™ TITANIUM Reinforcement
- BLACK TUSQ XL® NUT
- Figured Maple Top/Mahogany Body
- Medium frets
- MR-4 bridge (16.5mm string spacing)
- Nordstrand™ Big Single 5 neck pu
- Nordstrand™ Big Single 5 bridge pu
- EQB-IIISC 3-band eq
- Elixir® strings
- Hardware color : Gold
- Scale : 864mm/34"
- Colors : VNF (Vintage Natural Flat)

SR1200E VNF

- 5pc Atlas-4 Wenge/Bubinga neck w/KTS™ TITANIUM Reinforcement
- BLACK TUSQ XL® NUT
- Ovankol Top/Mahogany Body
- Medium frets
- MR-4 bridge (19.0mm string spacing)
- Nordstrand™ Big Single 4 neck pu
- Nordstrand™ Big Single 4 bridge pu
- EQB-IIISC 3-band eq
- Elixir® strings
- Hardware color : Gold
- Scale : 864mm/34"
- Colors : VNF (Vintage Natural Flat)

SR1205E VNF

- 5pc Atlas-5 Wenge/Bubinga neck w/KTS™ TITANIUM Reinforcement
- BLACK TUSQ XL® NUT
- Ovankol Top/Mahogany Body
- Medium frets
- MR-4 bridge (16.5mm string spacing)
- Nordstrand™ Big Single 5 neck pu
- Nordstrand™ Big Single 5 bridge pu
- EQB-IIISC 3-band eq
- Elixir® strings
- Hardware color : Gold
- Scale : 864mm/34"
- Colors : VNF (Vintage Natural Flat)

SR

Since 1987, musicians all over the world have come to know the playing comfort and unique sound of the SR bass. This year's lineup includes a wide array of options sure to fit just about any style of music. With 3-band EQ and its Mid-Frequency Select switch, or the Style Sweeper 3-band EQ controls, the SR basses can produce any sound you require.



SR750 BSF

- 5pc SR4 Jatoba/Bubinga neck
- Walnut/Mahogany wing body w/Maple center block
- Medium frets
- Accu-Cast B20 bridge (19mm string spacing)
- Bartolini® MK1 neck pu
- Bartolini® MK1 bridge pu
- EQB-IIIS 3-band eq
- Elixir® strings
- Hardware color : Gold
- Scale : 864mm/34"
- Color : BSF (Brown Sunburst Flat)

SR755 BSF

- 5pc SR5 Jatoba/Bubinga neck
- Walnut/Mahogany wing body w/Maple center block
- Medium frets
- Accu-Cast B25 bridge (16.5mm string spacing)
- Bartolini® MK1 neck pu
- Bartolini® MK1 bridge pu
- EQB-IIIS 3-band eq
- Elixir® strings
- Hardware color : Gold
- Scale : 864mm/34"
- Color : BSF (Brown Sunburst Flat)



Dustin Davidson
—August Burns Red



SR700 CN
CN (Charcoal Brown)

SR700

- 5pc SR4 Jatoba/Bubinga neck
- Figured Maple/Mahogany wing body w/Maple center block
- Medium frets
- Accu-Cast B20 bridge (19mm string spacing)
- Bartolini® MK1 neck pu
- Bartolini® MK1 bridge pu
- EQB-IIIS 3-band eq
- Elixir® strings
- Hardware color : Cosmo Black
- Scale : 864mm/34"
- Colors : CN (Charcoal Brown) AM (Amber)



SR700 AM
AM (Amber)



SR705 TK
TK (Transparent Black)

SR705

- 5pc SR5 Jatoba/Bubinga neck
- Figured Maple/Mahogany wing body w/Maple center block
- Medium frets
- Accu-Cast B25 bridge (16.5mm string spacing)
- Bartolini® MK1 neck pu
- Bartolini® MK1 bridge pu
- EQB-IIIS 3-band eq
- Elixir® strings
- Hardware color : Cosmo Black
- Scale : 864mm/34"
- Colors : TK (Transparent Black) NT (Natural)



SR705 NT
NT (Natural)



SR706 TK

- 5pc SR6 Jatoba/Bubinga neck
- Figured Maple/Mahogany wing body w/Maple center block
- Medium frets
- B106 bridge (16.5mm string spacing)
- Bartolini® MK1 neck pu
- Bartolini® MK1 bridge pu
- EQB-IIIS 3-band eq
- Elixir® strings
- Hardware color : Cosmo Black
- Scale : 864mm/34"
- Color : TK (Transparent Black)



SR600 WNF
WNF (Walnut Flat)

SR600

- 5pc SR4 Jatoba/Bubinga neck
- Ash body
- Medium frets
- Accu-Cast B20 bridge (19mm string spacing)
- Bartolini® MK1 neck pu
- Bartolini® MK1 bridge pu
- EQB-IIIS 3-band eq
- Elixir® strings
- Hardware color : Black Matte
- Scale : 864mm/34"
- Colors : WNF (Walnut Flat)
NTF (Natural Flat)

SR600 NTF
NTF (Natural Flat)

SR605 NTF
NTF (Natural Flat)

SR605

- 5pc SR5 Jatoba/Bubinga neck
- Ash body
- Medium frets
- Accu-Cast B25 bridge (16.5mm string spacing)
- Bartolini® MK1 neck pu
- Bartolini® MK1 bridge pu
- EQB-IIIS 3-band eq
- Elixir® strings
- Hardware color : Black Matte
- Scale : 864mm/34"
- Colors : WNF (Walnut Flat)
NTF (Natural Flat)

SR605 WNF
WNF (Walnut Flat)



Jatoba/Bubinga Slim Neck
Coupling Jatoba with Bubinga has made the neck strong and stable despite its thinness.



Bartolini® MK1 Pickups

The MK1 pickups are split coil designs that provides a very wide frequency range and enhanced definition for maximum accuracy. The Neck and Bridge pickups have equal response, like traditional single coils, but without the hum and noise.



SR500 BM

- 5pc SR4 Jatoba/Bubinga neck
- Mahogany body
- Medium frets
- Accu-Cast B20 bridge (19mm string spacing)
- Bartolini® MK1 neck pu
- Bartolini® MK1 bridge pu
- EQB-IIIS 3-band eq
- Elixir® strings
- Hardware color : Cosmo Black
- Scale : 864mm/34"
- Color : BM (Brown Mahogany)



SR505 BM

- 5pc SR5 Jatoba/Bubinga neck
- Mahogany body
- Medium frets
- Accu-Cast B25 bridge (16.5mm string spacing)
- Bartolini® MK1 neck pu
- Bartolini® MK1 bridge pu
- EQB-IIIS 3-band eq
- Elixir® strings
- Hardware color : Cosmo Black
- Scale : 864mm/34"
- Color : BM (Brown Mahogany)



SR506 BM

- 5pc SR6 Jatoba/Bubinga neck
- Mahogany body
- Medium frets
- B106 bridge (16.5mm string spacing)
- Bartolini® MK1 neck pu
- Bartolini® MK1 bridge pu
- EQB-IIIS 3-band eq
- Elixir® strings
- Hardware color : Cosmo Black
- Scale : 864mm/34"
- Color : BM (Brown Mahogany)



SR500M BM

- 5pc SR4 Maple/Rosewood neck
- Mahogany body
- Medium frets
- Accu-Cast B20 bridge (19mm string spacing)
- Bartolini® MK1 neck pu
- Bartolini® MK1 bridge pu
- EQB-IIIS 3-band eq
- Elixir® strings
- Hardware color : Cosmo Black
- Scale : 864mm/34"
- Color : BM (Brown Mahogany)



SR505M BM

- 5pc SR5 Maple/Rosewood neck
- Mahogany body
- Medium frets
- Accu-Cast B25 bridge (16.5mm string spacing)
- Bartolini® MK1 neck pu
- Bartolini® MK1 bridge pu
- EQB-IIIS 3-band eq
- Elixir® strings
- Hardware color : Cosmo Black
- Scale : 864mm/34"
- Color : BM (Brown Mahogany)



SR506M BM

- 5pc SR6 Maple/Rosewood neck
- Mahogany body
- Medium frets
- B106 bridge (16.5mm string spacing)
- Bartolini® MK1 neck pu
- Bartolini® MK1 bridge pu
- EQB-IIIS 3-band eq
- Elixir® strings
- Hardware color : Cosmo Black
- Scale : 864mm/34"
- Color : BM (Brown Mahogany)



SR400QM CNB
CNB (Charcoal Brown Burst)

SR400QM TLB
TLB (Transparent Lavender Burst)

SR405QM CNB
CNB (Charcoal Brown Burst)

SR405QM TGB
TGB (Transparent Gray Burst)

SR400QM

- 5pc SR4 Maple/Rosewood neck
- Quilted Maple top/Mahogany body
- Medium frets
- Accu-Cast B20 bridge (19mm string spacing)
- CAP EXF-N2 neck pu
- CAP EXF-N2 bridge pu
- EQB-IIID 3-band eq
- Elixir® strings
- Hardware color : Cosmo Black
- Scale : 864mm/34"
- Colors : CNB (Charcoal Brown Burst)
TLB (Transparent Lavender Burst)

SR405QM

- 5pc SR5 Maple/Rosewood neck
- Quilted Maple top/Mahogany body
- Medium frets
- Accu-Cast B25 bridge (16.5mm string spacing)
- CAP EXF-N2 neck pu
- CAP EXF-N2 bridge pu
- EQB-IIID 3-band eq
- Elixir® strings
- Hardware color : Cosmo Black
- Scale : 864mm/34"
- Colors : CNB (Charcoal Brown Burst)
TGB (Transparent Gray Burst)



Rufus Philpot



Marco Coti Zelati
-Lacuna Coil



SR370M BBT

- 5pc SR4 Maple/Rosewood neck
- Maple body
- Medium frets
- B100 bridge (19mm string spacing)
- EXF-4F neck pu
- EXF-4R bridge pu
- EQB-IIIB Style Sweeper 3-band eq
- Hardware color : Cosmo Black
- Scale : 864mm/34"
- Color : BBT (Brown Burst)

SR375M BBT

- 5pc SR5 Maple/Rosewood neck
- Maple body
- Medium frets
- B105 bridge (16.5mm string spacing)
- EXF-SF neck pu
- EXF-SR bridge pu
- EQB-IIIB Style Sweeper 3-band eq
- Hardware color : Cosmo Black
- Scale : 864mm/34"
- Color : BBT (Brown Burst)

SR



SR300 IPT
IPT (Iron Pewter)



SR300 ROM
ROM (Roadster Orange Metallic)



SR300 CA
CA (Candy Apple)



SR300 NM
NM (Navy Metallic)



SR300 PW
PW (Pearl White)

SR300

- 5pc SR4 Maple/Rosewood neck
- Agathis body
- Medium frets
- B100 bridge (19mm string spacing)
- EXF-4F neck pu
- EXF-4R bridge pu
- EQB-IIIB Style Sweeper 3-band eq
- Hardware color : Cosmo Black
- Scale : 864mm/34"
- Colors : IPT (Iron Pewter)
ROM (Roadster Orange Metallic)
CA (Candy Apple)
NM (Navy Metallic)
PW (Pearl White)
- Also available left-handed in IPT finish



SR305 IPT
IPT (Iron Pewter)

SR305 CA
CA (Candy Apple)

SR305

- 5pc SR5 Maple/Rosewood neck
- Agathis body
- Medium frets
- B105 bridge (16.5mm string spacing)
- EXF-5F neck pu
- EXF-5R bridge pu
- EQB-IIIB Style Sweeper 3-band eq
- Hardware color : Cosmo Black
- Scale : 864mm/34"
- Colors : IPT (Iron Pewter)
CA (Candy Apple)

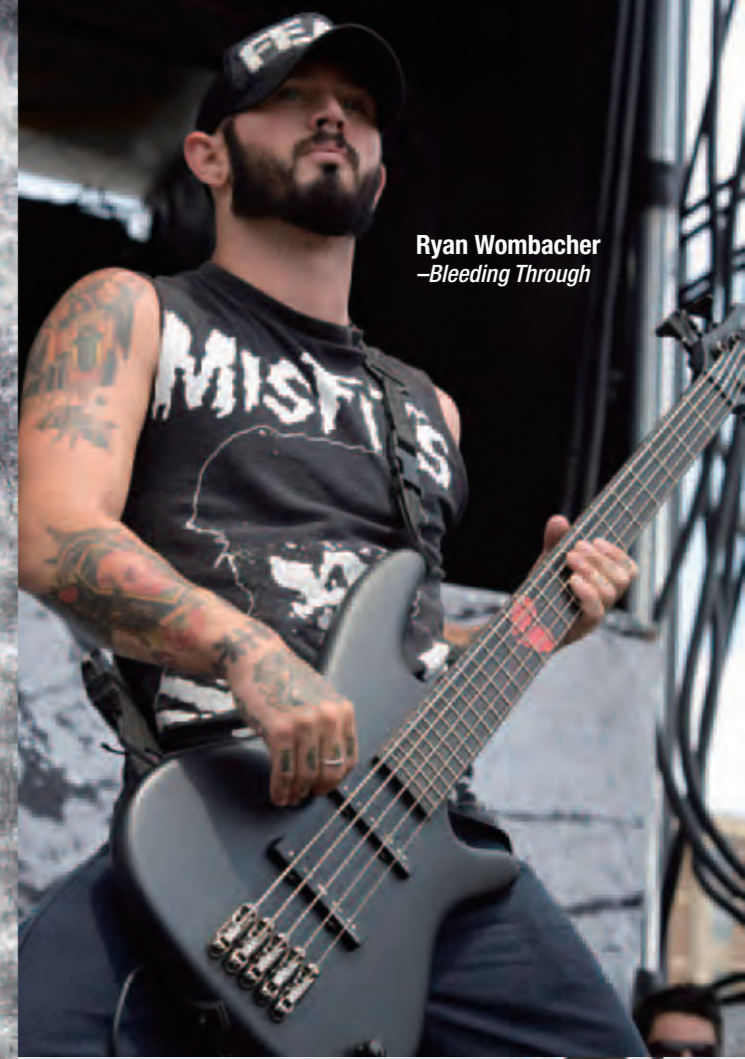

Ryan Wombacher
-Bleeding Through



Stephane Barbe
-Kataklysm

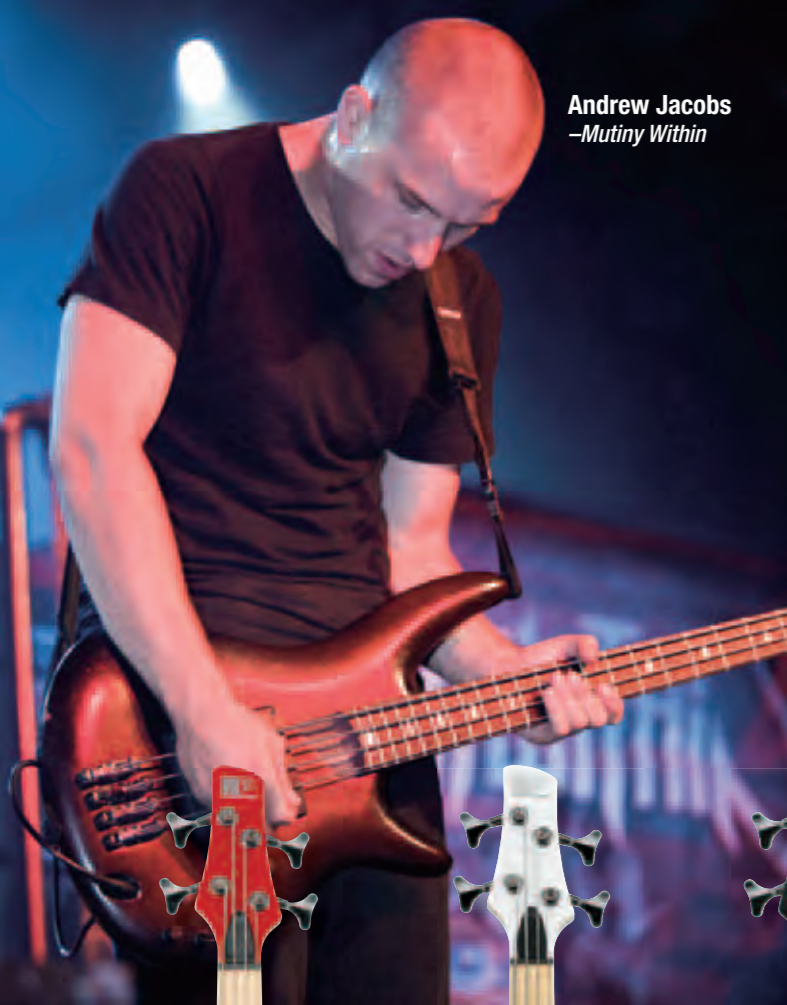

Andrew Jacobs
—Mutiny Within



Buzzard
—36 Crazyfists



Jon "Slo" Maggard
—Unearth



Adam Nitti



SR300M CA
CA (Candy Apple)



SR300M PW
PW (Pearl White)



SR300M IPT
IPT (Iron Pewter)

SR300M

- 5pc SR4 Maple/Rosewood neck
- Agathis body
- Medium frets
- B100 bridge (19mm string spacing)
- EXF-4F neck pu
- EXF-4R bridge pu
- EQB-IIIB Style Sweeper 3-band eq
- Hardware color : Cosmo Black
- Scale : 864mm/34"
- Colors : CA (Candy Apple)
PW (Pearl White)
IPT (Iron Pewter)

SR300PWF

- 5pc SR4 Maple/Rosewood neck
- Agathis body
- Fretless
- B100 bridge (19mm string spacing)
- EXF-4F neck pu
- EXF-4R bridge pu
- EQB-IIIB Style Sweeper 3-band eq
- Hardware color : Cosmo Black
- Scale : 864mm/34"
- Color : PW (Pearl White)



SR305M PW
PW (Pearl White)



SR



SR305M

- 5pc SR5 Maple/Rosewood neck
- Agathis body
- Medium frets
- B105 bridge (16.5mm string spacing)
- EXF-5F neck pu
- EXF-5R bridge pu
- EQB-IIIB Style Sweeper 3-band eq
- Hardware color : Cosmo Black
- Scale : 864mm/34"
- Colors : PW (Pearl White)
SLB (Starlight Blue)

SR305M SLB
SLB (Starlight Blue)



Photo by Sebastien Paquet



Photo by Oskar Allerby

SRT

Neck-thru construction for longer sustain and US-made EMG® pickups push these animals into the realm of modern, hi-tech sound. The EMG® 40DC pickups reproduce just about anything from the cleanest highs right down to the dirtiest growling lows. Add perfect 3D-contoured ergonomics, arched top and scooped back body and you have “The Modern Bass” – ultimate gear for today’s bass race.

KoRN FIELDY SIGNATURE MODEL

A lightweight bass but with some seriously heavy tone. With active pickups and the 3-band eq, any sound is possible. Korn’s sound. Your sound.

K5 BKF

- 5pc K5 Maple/Bubinga neck
- Mahogany body
- Medium frets
- Die-Cast EB-7 bridge (16.5mm string spacing)
- ADX5N neck pu
- ADX5B bridge pu
- Vari-Mid III 3-band eq
- Elixir® strings
- Hardware color : Black
- Scale : 864mm/34"
- Color : BKF (Black Flat)



IN FLAMES PETER IWERS SIGNATURE MODEL

Iwers’ bass playing in the band In Flames is as aggressive and ruthless as you can get, and this rock bass is built to take anything that comes its way. Just one look at its 5pc Maple/Bubinga neck, Maple body, and dramatic inlay over a Pearl White finish is all it takes to realize that this bass is a true battle axe.

PIB2 PW

- 5pc PIB Maple/Bubinga neck
- Maple body
- Medium frets
- MR-4 bridge (16.5mm string spacing)
- USA Bartolini® Custom neck pu
- USA Bartolini® Custom bridge pu
- 1-volume control w/PIB Active circuit
- D’Addario® strings
- Hardware color : Gold
- Scale : 864mm/34"
- Factory Tuning : 1D#, 2A#, 3F, 4C, 5A#
- String Gauge : .045/ .065/ .085/ .105/ .120
- Color : PW (Pearl White)



SRT800DX AM
AM (Amber)



SRT800DX TG
TG (Transparent Gray)



SRT800DX

- 5pc SR4 Maple/Bubinga neck-thru
- Figured Maple/Mahogany wing body
- Medium frets
- Accu-Cast B20 bridge (19mm string spacing)
- EMG®40DC neck pu
- EMG®40DC bridge pu
- Vari-Mid III 3-band eq
- Elixir® strings
- Hardware color : Cosmo Black
- Scale : 864mm/34"
- Colors : AM (Amber) TG (Transparent Gray)

SRT805DX CN

- 5pc SR5 Maple/Bubinga neck-thru
- Figured Maple/Mahogany wing body
- Medium frets
- Accu-Cast B25 bridge (16.5mm string spacing)
- EMG®40DC neck pu
- EMG®40DC bridge pu
- Vari-Mid III 3-band eq
- Elixir® strings
- Hardware color : Cosmo Black
- Scale : 864mm/34"
- Color : CN (Charcoal Brown)

SRT/ EMG® Pickups

The EMG DC pickups on the SRT models offer plenty of output with balanced tonality.



Thru-neck

SRT’s neck-thru construction supplies longer sustain and brighter sound than traditional bolt-on necks.

SRA

We forged the "Slim & Fast" of the SR with the "Heavy Bottom" of the SRX and got a new monster: the SRA. The EMG® HZ pickups are onboard, for smoother attack and a flatter high end. From classic rock to heavy metal, these pickups perform. The 500 series features beautiful quilted maple tops, with EQB-IIIC 3-band eq. SRAs are the perfect answer for players who want heavy sound without the heavy price.



Brandon Leitru
-For Today
 Photo by Steadfast Media



SRA500

- 3pc SRA4 Maple neck
- Quilted Maple top/Mahogany body
- Medium frets
- Accu-Cast B20 bridge (19mm string spacing)
- EMG®35HZ neck pu
- EMG®35HZ bridge pu
- EQB-IIIC 3-band eq
- Elixir® strings
- Hardware color : Cosmo Black
- Scale : 864mm/34"
- Colors : AM (Amber)
 TK (Transparent Black)
 TGR (Transparent Green)

SRA500 AM
 AM (Amber)

SRA500 TK
 TK (Transparent Black)

SRA500 TGR
 TGR (Transparent Green)



SRA505 BB

- 3pc SRA5 Maple neck
- Quilted Maple top/Mahogany body
- Medium frets
- Accu-Cast B25 bridge (16.5mm string spacing)
- EMG®40HZ neck pu
- EMG®40HZ bridge pu
- EQB-IIIC 3-band eq
- Elixir® strings
- Hardware color : Cosmo Black
- Scale : 864mm/34"
- Color : BB (Blackberry)



SRA300 IPT
 IPT (Iron Pewter)

SRA300

- 3pc SRA4 Maple neck
- Mahogany body
- Medium frets
- B10 bridge (19mm string spacing)
- EMG®35HZ neck pu
- EMG®35HZ bridge pu
- Phat II eq
- Elixir® strings
- Hardware color : Black
- Scale : 864mm/34"
- Colors : IPT (Iron Pewter)
 PW (Pearl White)
 MRS (Metallic Red Sunburst)



SRA300 PW
 PW (Pearl White)



SRA300 MRS
 MRS (Metallic Red Sunburst)



SRA305 IPT

- 3pc SRA5 Maple neck
- Mahogany body
- Medium frets
- B15 bridge (16.5mm string spacing)
- EMG®40HZ neck pu
- EMG®40HZ bridge pu
- Phat II eq
- Elixir® strings
- Hardware color : Black
- Scale : 864mm/34"
- Color : IPT (Iron Pewter)

Arched Top

SRA basses feature contoured arched tops with flat-back bodies.

SRA/EMG® Pickups

The EMG® HZ pickups on the SRA models offer plenty of output with balanced tonality.



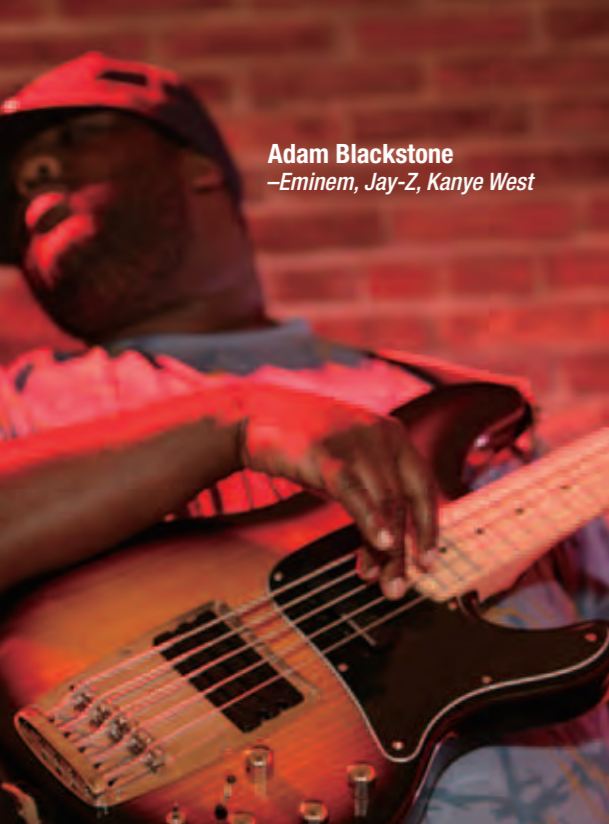

Adam Blackstone
—Eminem, Jay-Z, Kanye West



Mark Young
—(HED)p.e.

ATK

The ATK may be the most straightforward bass in the entire Ibanez line. With its iconic Double Humbucker pickup, however, players can get three distinctive bass sounds to fit any genre or playing style instantly with a flick of a switch.



ATK200 BK
BK (Black)

ATK200

- 3pc ATK4 Maple neck
- Ash body
- Medium frets
- ATK4 bridge (19mm string spacing)
- CAP Double Humbucker bridge pu
- ATK N2 3-band eq
- Elixir® strings
- Hardware color : Chrome
- Scale : 864mm/34"
- Colors : BK (Black) NT (Natural)

ATK200 NT
NT (Natural)

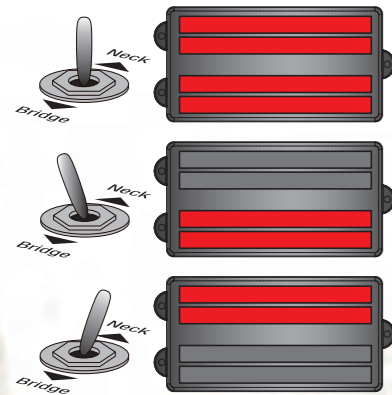

CAP Double Humbucker

ATK200 features the original Ibanez Double Humbucker pickup, which offers three distinct sounds for all styles of playing. There are two humbucking coils inside one pickup, which can minimize noise by hum cancelling in each pickup position (neck, bridge and combined.) With each position, you will get a different tonal character of the ATK200.

String-thru body

Thru-body stringing offers enhanced articulation with increased sustain.



PAUL GRAY

Slipknot

1972-2010
REST IN PEACE



PGB2T

- PGBT4 Maple neck
- Mahogany body
- Medium frets
- B10 bridge
- STD-M bridge pu
- Hardware color : Cosmo Black
- Scale : 864mm/34"

PAUL GRAY

TRIBUTE MODEL

Paul Gray was a long time Ibanez endorser and we are deeply honored to have partnered with him over his career, including the opportunity to work with him on his signature ATK bass. We are pleased to offer the Paul Gray Tribute model to commemorate his significant impact on the world of music and his legacy with Slipknot. He will be greatly missed by us all.



Paul Romanko
—Shadows Fall



Carol Kaye



Nelson Braxton
—Braxton Bros, Michael Bolton

SRX

The SRX is the muscular big brother of the SR series. This is a bass that was designed for heavier playing styles, and it meets that demand in a no-nonsense layout. The EQB-II DX 2-band EQ makes it easy to find various sounds, and the now-famous stock Ibanez PFR pickups, which major artists rave about, are right there to give you that extra punch.



SRX350 NT

- 3pc SRX4 Maple neck
- Ash body
- Medium frets
- Accu-Cast B200 bridge (19mm string spacing)
- PFR-N4 neck pu
- PFR-B4 bridge pu
- EQB-II DX 2-band eq
- Hardware color: Chrome
- Scale: 864mm/34"
- Color: NT (Natural)

SRX355 NT

- 3pc SRX5 Maple neck
- Ash body
- Medium frets
- Accu-Cast B205 bridge (18mm string spacing)
- PFR-N5 neck pu
- PFR-B5 bridge pu
- EQB-II DX 2-band eq
- Hardware color: Chrome
- Scale: 864mm/34"
- Color: NT (Natural)



MIKE KILLSWITCH ENGAGE D'ANTONIO SIGNATURE MODEL

Sometimes straightforward brute force is the only answer. Killswitch Engage's Mike D'Antonio would agree. His signature MDB2, modeled after the SRX700, has a simplified layout of only one volume control and two PFR high-output pickups. Mike's striking laser-engraved graphic will ensure you get noticed while you're raging on this beast.

MDB2 BM

- 5pc MDB Maple/Walnut neck-thru
- Mahogany wing body
- Medium frets
- Accu-Cast B200 bridge (19mm string spacing)
- PFR-ALN4 neck pu • PFR-ALB4 bridge pu
- 1-volume control w/MDB Active circuit
- D'Addario® strings
- Hardware color: Cosmo Black
- Scale: 864mm/34"
- Factory Tuning: 1F, 2C, 3G, 4C
- String Gauge: .055/.075/.095/.120
- Color: BM (Brown Mahogany)



ARCH ENEMY SHARLEE D'ANGELO SIGNATURE MODEL

Any bass that takes the stage night after night with Arch Enemy has to take a brutal pounding without sacrificing tone. Made to Sharlee's custom specs with powerful PFR pickups and Iron Cross neck inlays, the Iceman-inspired SDB1 looks as sinister as it sounds.

SDB1 BKF

- 5pc SDB Maple/Bubinga neck-thru
- Mahogany wing body
- Medium frets
- MR-4 bridge (19mm string spacing)
- PFR-N4 neck pu (black pole piece)
- PFR-B4 bridge pu (black pole piece)
- EQB-II DX 2-band eq
- D'Addario® strings
- Hardware color: Cosmo Black
- Scale: 864mm/34"
- Factory Tuning: 1D#, 2A#, 3F, 4C
- String Gauge: .060/.080/.100/.120
- Color: BKF (Black Flat)





Roland Guerin
– *Allen Toussaint*

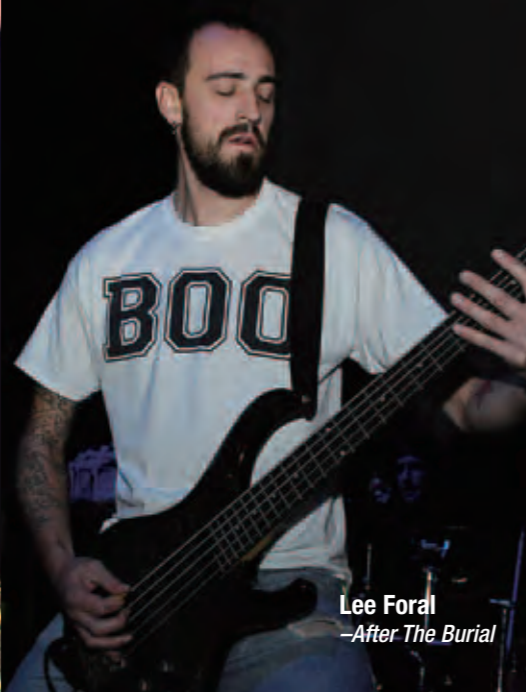

Lee Foral
– *After The Burial*



Jason White
– *Straight Line Stitch*
Photo by Das Buddha



Matt Snell
– *Five Finger Death Punch*

ARTCORE

The Artcore Bass series was designed for players that are used to solid body basses but want the acoustic tone of a hollow body. The 30" scale neck increases playing comfort, and the acoustic body widens the palette of sounds at your disposal.

BTB

The concepts behind boutique basses are often the justification for making them extremely expensive. With the BTB, however, Ibanez decided that these same concepts of well-selected body materials, a 35" neck scale, and deep cutaways could be applied to an instrument that anyone could afford. All BTB basses feature neck-thru construction and deeper cutaways for enhanced playability and balance.



Stephen Bruner
– *Suicidal Tendencies*



BTB775PB CN

- 5pc BTB5 Maple/Bubinga neck-thru
- Poplar Burl top/Mahogany wing body
- Medium frets
- MR-2 bridge (19mm string spacing)
- Bartolini® MK2 neck pu
- Bartolini® MK2 bridge pu
- Bartolini® MK2 3-band eq
- Elixir® strings
- Hardware color : Cosmo Black
- Scale : 889mm/35"
- Color : CN (Charcoal Brown)



BTB776PB AM

- 5pc BTB6 Maple/Bubinga neck-thru
- Poplar Burl top/Mahogany wing body
- Medium frets
- MR-2 bridge (17mm string spacing)
- Bartolini® MK2 neck pu
- Bartolini® MK2 bridge pu
- Bartolini® MK2 3-band eq
- Elixir® strings
- Hardware color : Cosmo Black
- Scale : 889mm/35"
- Color : AM (Amber)



BTB675 NTF

- 5pc BTB5 Maple/Bubinga neck-thru
- Walnut/Ash wing body
- Medium frets
- MR-2 bridge (19mm string spacing)
- Bartolini® MK2 neck pu
- Bartolini® MK2 bridge pu
- Bartolini® MK2 3-band eq
- Elixir® strings
- Hardware color : Cosmo Black
- Scale : 889mm/35"
- Color : NTF (Natural Flat)



BTB676 NTF

- 5pc BTB6 Maple/Bubinga neck-thru
- Walnut/Ash wing body
- Medium frets
- MR-2 bridge (17mm string spacing)
- Bartolini® MK2 neck pu
- Bartolini® MK2 bridge pu
- Bartolini® MK2 3-band eq
- Elixir® strings
- Hardware color : Cosmo Black
- Scale : 889mm/35"
- Color : NTF (Natural Flat)



AGB200 TBR

- 3pc Artcore Bass Mahogany/Maple set-in neck
- Maple top/back/sides
- Medium frets
- Gibraltar III bass bridge (19mm string spacing)
- Quik Change III bass tailpiece
- ACHB-2 neck pu
- ACHB-2 bridge pu
- D'Addario® Strings
- Hardware color : Gold
- Scale : 770mm/30.3"
- Depth: 43mm at tail
- String Gauge: .050/.070/.085/.105
- Color : TBR (Transparent Brown)

AFB200 BS

- 3pc Artcore Bass Mahogany/Maple set-in neck
- Maple top/back/sides
- Medium frets
- Wooden bridge (19mm string spacing)
- FBT40 tailpiece
- ACHB-2 neck pu
- ACHB-2 bridge pu
- D'Addario® Strings
- Hardware color : Gold
- Scale : 770mm/30.3"
- Depth: 70mm at tail
- String Gauge: .050/.070/.085/.105
- Color : BS (Brown Sunburst)



Jeanne Sagan
– *All That Remains*

GSR

GSRs offer famous Soundgear sleekness, comfort, tone, and playability, and the GSR Mikro basses are for anyone who needs a compact axe or the comfort of a smaller neck (especially young rockers). The GARTB brings classic single-cutaway style into play, for a more distinctive look along with affordability. The GATK20—the most basic version of the ATK—gives you a huge rock sound straightaway from the same big ATK body.



GSR200FM TRB
TRB (Transparent Red Burst)



GSR200FM TBB
TBB (Transparent Blue Burst)



GSR200FM AMB
AMB (Amber Burst)



GSR205FM TK

- GSR5 Maple neck
- Flamed Maple top/Nato body
- Medium frets
- B15 bridge (16.5mm string spacing)
- DXH-5N neck pu
- DXH-5B bridge pu
- Phat II eq
- Hardware color : Chrome
- Scale : 864mm/34"
- Color : TK (Transparent Black)



GSR206 BK
BK (Black)

GSR206 BK

- GSR6 Maple neck
- Agathis body
- Medium frets
- B16 bridge (16.5mm string spacing)
- DXH-6N neck pu
- DXH-6B bridge pu
- Phat II eq
- Hardware color : Chrome
- Scale : 864mm/34"
- Color : BK (Black)
- Also available left-handed in BK finish



GSR206 BKL
BK (Black)

GSR



GSR200 BK
BK (Black)

GSR200

- GSR4 Maple neck
- Agathis body
- Medium frets
- B10 bridge (19mm string spacing)
- PSNDP neck pu
- PSNDJ bridge pu
- Phat II eq
- Hardware color : Chrome
- Scale : 864mm/34"
- Colors : BK (Black)
- JB (Jewel Blue)
- TR (Transparent Red)
- PW (Pearl White)
- ROM (Roadster Orange Metallic)
- Also available left-handed in BK finish



GSR200 JB
JB (Jewel Blue)



GSR200 TR
TR (Transparent Red)



GSR200 PW
PW (Pearl White)



GSR205 BK
BK (Black)

GSR205

- GSR5 Maple neck
- Agathis body
- Medium frets
- B15 bridge (16.5mm string spacing)
- DXH-5N neck pu
- DXH-5B bridge pu
- Phat II eq
- Hardware color : Chrome
- Scale : 864mm/34"
- Colors : BK (Black)
- ROM (Roadster Orange Metallic)
- Also available left-handed in BK finish



GSR205 ROM
ROM (Roadster Orange Metallic)



GSR205 BKL
BK (Black)

GSR AND GSRM



GSR250M BK
BK (Black)



GSR250M LSB
LSB (Light Sky Blue)



GSR250M WH
WH (White)



GSR100EX

- GSR4 Maple neck
- Mahogany body
- Medium frets
- B10 bridge (19mm string spacing)
- PPD4 pu
- Hardware color : Chrome
- Scale : 864mm/34"
- Colors : TMM (Traditional Matte Mahogany)
- BK (Black)



GSR105EX BK

- GSR5 Maple neck
- Basswood body
- Medium frets
- B15 bridge (16.5mm string spacing)
- PPD5 pu
- Hardware color : Chrome
- Scale : 864mm/34"
- Color : BK (Black)



GSRM20 BK
BK (Black)



GSRM20 PW
PW (Pearl White)



GSRM20 SLB
SLB (Starlight Blue)



GSRM20 MPL
MPL (Metallic Purple)



GSRM20 BKL

- Left-Handed
- GSRM Maple neck
- Basswood body
- Medium frets
- B10 bridge (19mm string spacing)
- STD-P neck pu
- STD-J bridge pu
- Hardware color : Chrome
- Scale : 726.2mm/28.6"
- Color : BK (Black)

GSRM20

- GSRM Maple neck
- Basswood body
- Medium frets
- B10 bridge (19mm string spacing)
- STD-P neck pu
- STD-J bridge pu
- Hardware color : Chrome
- Scale : 726.2mm/28.6"
- Colors : BK (Black)
- PW (Pearl White)
- SLB (Starlight Blue)
- MPL (Metallic Purple)

GATK AND GARTB



GATK20 CA
CA (Candy Apple)



GATK20

- GATK4 Maple neck
- Basswood body
- Medium frets
- B10 bridge (19mm string spacing)
- STD-M bridge pu
- Hardware color : Chrome
- Scale : 864mm/34"
- Colors : CA (Candy Apple) BK (Black)

GATK20 BK
BK (Black)



GARTB20 BK
BK (Black)



GARTB20 TR
TR (Transparent Red)



GARTB20

- GARTB Maple neck
- Basswood body
- Medium frets
- B10 bridge (19mm string spacing)
- DXH-4N neck pu
- DXH-4B bridge pu
- Hardware color : Chrome
- Scale : 770mm/30.3"
- Colors : BK (Black) TR (Transparent Red) MSS (Metallic Silver Sunburst)

GATK20 MSS
MSS (Metallic Silver Sunburst)

JUMPSTART

When we say "Everything you need to get out and gig," we mean everything—amp, axe, accessories. All it takes is you and your desire to make your dreams real—to get out of the audience and up on stage where you belong.



IJSB90

- Maple GSR4 neck
- Basswood body
- Medium frets
- B10 bridge
- STD P neck pu
- BK (Black)



IJXB190

- Maple GSR4 neck
- Basswood body
- Medium frets
- B10 bridge
- STD P neck pu
- STD J bridge pu
- BK (Black) / TR (Transparent Red) / JB (Jewel Blue)



IJXB190 ACCESSORIES

- IBZ15B 15W Amp
- Electronic Tuner
- Headphones
- Gig Bag
- Bass Guitar Strap
- Picks & Cable
- Accessory Pouch
- Free on-line bass lessons

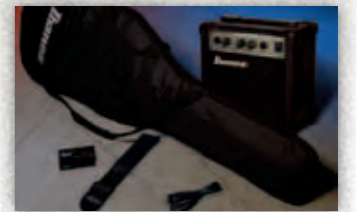

IJSB90BK & IJMB15BK ACCESSORIES

- IBZ1B 10 Watt Amp
- Electronic Tuner
- Gig Bag
- Bass Guitar Strap
- Cable
- Free on-line bass lessons

IJMB15

- Maple 28.6" scale GSRM4 neck
- Basswood body
- Medium frets
- B10 bridge
- STD P neck pu
- BK (Black)





GERALD VEASLEY SIGNATURE MODEL

Smooth, rapturous, fluid – some of the ways to describe the sounds that world renowned Jazz bassist Gerald Veasley coaxes from his signature Ibanez bass. Gerald's six-string bass features an Alder body and gorgeous Figured Maple top. It has a special string spacing of 14mm at its Mono-Rail bridge, compared to our usual 16.5mm spacing, allowing Gerald to play chords with ease according to his playing style. Add in the Bartolini® pickups and you have THE Veasley Bass.



Aguilar® OBP-3 preamp
GVB1006 features the Aguilar® OBP-3 3-band eq, with ultra flexibility. It provides ± 18 dB of cut/boost at 40Hz, ± 16 dB of cut/boost at either 400Hz or 800Hz and ± 16 dB of treble cut/boost at 6.5 kHz. The mid frequency can be set to 400Hz or 800Hz by push/pull switch, both considered very important and useful frequencies for the bass.

GVB1006 AM

- 3pc GVB Maple/Wenge neck
- Figured Maple top/Alder body
- Medium frets
- MR-4 bridge (14mm string spacing)
- Bartolini® P45C-B neck pu
- Bartolini® P45C-T bridge pu
- Aguilar® OBP-3
- Hardware color : Cosmo Black
- Scale : 864mm/34"
- String Gauge : .030/ .040/ .060/ .080/ .100/ .120
- Color : AM (Amber)



Finger Ramp

The detachable finger ramp, designed by Gary Willis, encourages players to not "dig in too deep" and allows a more consistent attack with quick recovery time.



GARY WILLIS SIGNATURE MODELS

From Triphasic bassist Gary Willis, the acclaimed master of the five-string fretless, comes the design of the GWB, a no-frits, finely tuned instrument made for the player who desires total dynamic and tonal control.



GWB1005 NTF

- 3pc GWB1005 Maple neck • Fretless
- Swamp Ash body
- STD-5 bridge (16.5mm string spacing)
- Bartolini® GWB pu
- Bartolini® NT BT 2-band eq
- D'Addario® strings • Hardware color : Black
- Scale : 864mm/34"
- Color : NTF (Natural Flat)



GWB35 BKF

- 3pc GWB35 Maple neck • Fretless
- Basswood body
- B105 bridge (16.5mm string spacing)
- SFR-GWB custom wound pu
- EQB-GWII 2-band eq
- D'Addario® strings • Hardware color : Black
- Scale : 864mm/34"
- Color : BKF (Black Flat)



Grooveline



G104 NT
NT(Natural)

G104 DE
DE(Deep Espresso)

G105 NT
NT(Natural)

G105 TOR
TOR(Transparent Orange)

G104

- 5pc Grooveline-4 Wenge/Bubinga neck w/KTS™ TITANIUM Reinforcement
- BLACK TUSQ XL® NUT
- Ash/Alder/Ash body
- Medium frets
- Tight End Bass 4 bridge (19.0mm string spacing)
- CAP Sonic Arch 4 neck pu
- CAP Sonic Arch 4 bridge pu
- E4 3-band eq
- Daddario® Strings
- Hardware color : Cosmo Black
- Scale : 864mm/34"
- Color : NT(Natural)
DE(Deep Espresso)

G105

- 5pc Grooveline-5 Wenge/Bubinga neck w/KTS™ TITANIUM Reinforcement
- BLACK TUSQ XL® NUT
- Ash/Alder/Ash body
- Medium frets
- Tight End Bass 5 bridge (18.0mm string spacing)
- CAP Sonic Arch 5 neck pu
- CAP Sonic Arch 5 bridge pu
- E5 3-band eq
- Daddario® Strings
- Hardware color : Cosmo Black
- Scale : 864mm/34"
- Color : NT(Natural)
DE(Deep Espresso)
TOR(Transparent Orange)

ATK *Prestige*

Although the ATK stands apart from most Ibanez basses in terms of its appearance and size, nothing is inferior in its response to players' demands for variety of sound and for playing comfort. The newly developed CAP Double Humbucker pickup allows you to get three distinct bass sounds with the flick of a switch. With the additional CAP Sonic Arch front pickup, you'll have a world of possibilities of sound and tone. Crafted in Japan by Ibanez's finest luthiers, the ATK Prestige is definitely the pro's choice in basses.

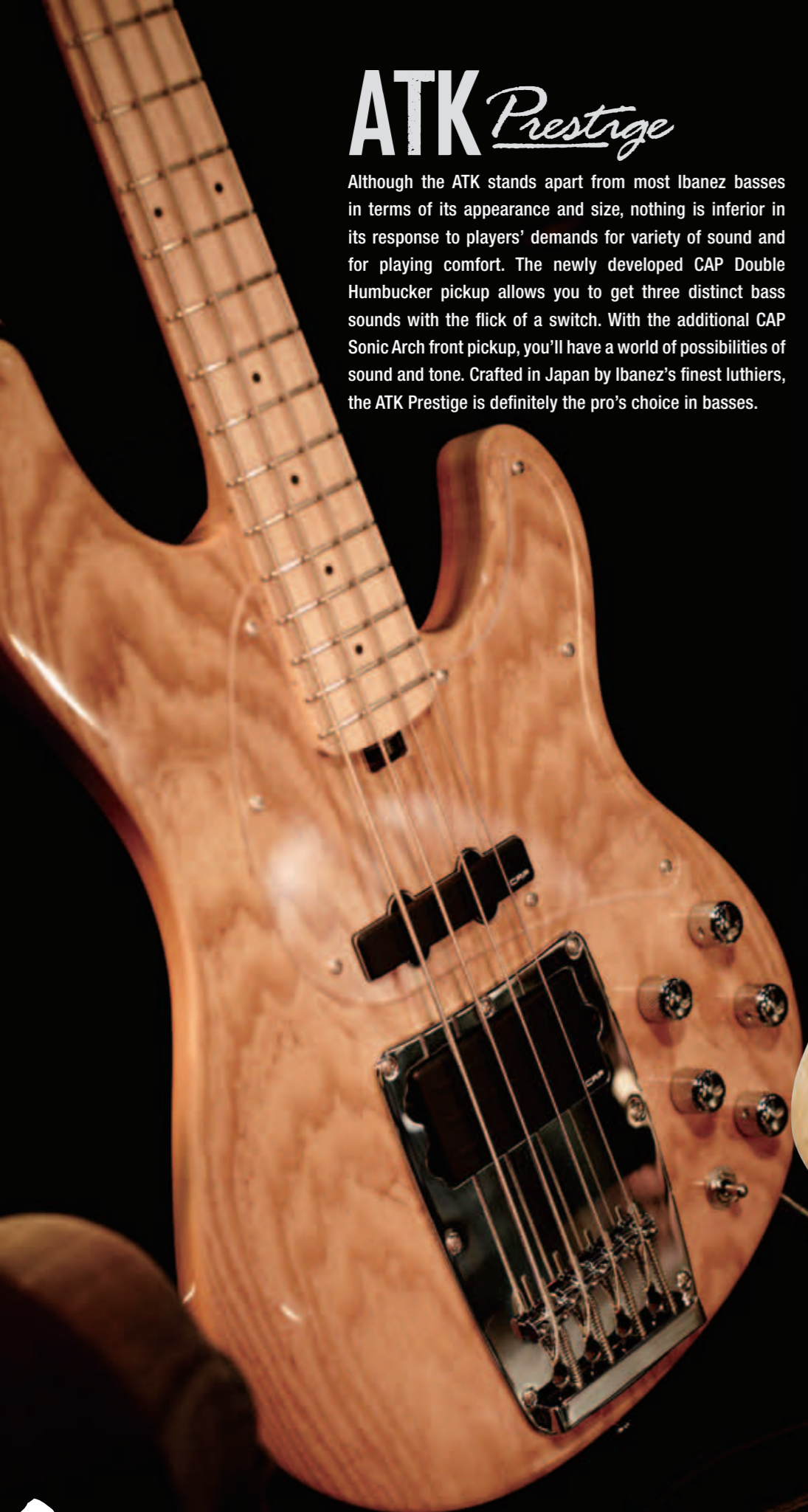

ATK1200 NT

- 3pc ATK4-HP Maple neck *Prestige*
- Ash body
- Medium frets
- ATK4 bridge (19mm string spacing)
- CAP Sonic Arch neck pu
- CAP Double Humbucker bridge pu
- ATK N3 3-band eq
- D'Addario® Strings
- Hardware color: Chrome
- Scale: 864mm/34"
- Color: NT (Natural)

SR *Prestige*

The SR Prestige is the pinnacle of playing comfort, smart design, and Japanese craftsmanship. All SR Prestige models are "Made in Japan" by the finest Ibanez craftsmen and from top-of-the-line components. They feature the Mono-Rail bridge design, with complete string-to-string isolation so that each string vibrates without interference from other strings, the newly developed Power Curve III EQ for vitalizing the low-end and midrange tones, and the same classic slim neck that has become an industry standard over the past 20 years.

USA Bartolini® pickup

The US made pickups are hand made at our factory in California exclusively for Ibanez. Ibanez was the first to ask for much deeper tone from the neck pickup while retaining a bright tone for the bridge, unlike traditional designs that used approximately equal pickup tone. The pickups are dual coil designs in several soapbar shapes, some rounded top and some flat top. In all cases, the Neck pickup tone is very deep and the Bridge pickup tone is bright. This allows the widest tonal sweep from the Blend control. Enjoy the wide tonal range! -Bill Bartolini-

MR4 Mono-Rail Bridge

The Mono-Rail Bridge is the ultimate in string isolation for bass. Each saddle is independently and securely locked down to the body for maximum vibration transfer and no interference. One screw controls the height of each saddle for easy adjustment.



SR5000E OL

- 5pc Atlas-4 HP Wenge/Bubinga neck *Prestige* w/KTS™ TITANIUM Reinforcement
- BLACK TUSQ XL® NUT
- Wenge/Mahogany/Wenge body
- Medium frets
- MR-4 bridge (19mm string spacing)
- USA Bartolini® Custom neck pu
- USA Bartolini® Custom bridge pu
- PWC III 3-band eq • Elixir® strings
- Hardware color: Gold
- Scale: 864mm/34"
- Color: OL(Oil)



SR5005E OL

- 5pc Atlas-5 HP Wenge/Bubinga neck *Prestige* w/KTS™ TITANIUM Reinforcement
- BLACK TUSQ XL® NUT
- Wenge/Mahogany/Wenge body
- Medium frets
- MR-4 bridge (16.5mm string spacing)
- USA Bartolini® Custom neck pu
- USA Bartolini® Custom bridge pu
- PWC III 3-band eq • Elixir® strings
- Hardware color: Gold
- Scale: 864mm/34"
- Color: OL(Oil)



SR5006E OL

- 5pc Atlas-6 HP Wenge/Bubinga neck *Prestige* w/KTS™ TITANIUM Reinforcement
- BLACK TUSQ XL® NUT
- Wenge/Mahogany/Wenge body
- Medium frets
- MR-4 bridge (16.5mm string spacing)
- USA Bartolini® Custom neck pu
- USA Bartolini® Custom bridge pu
- PWC III 3-band eq • Elixir® strings
- Hardware color: Gold
- Scale: 864mm/34"
- Color: OL(Oil)



SR4500E DE

- 5pc Atlas-4 HP Maple/Bubinga neck *Prestige* w/KTS™ TITANIUM Reinforcement
- BLACK TUSQ XL™ NUT
- Ash body
- Medium frets
- MR-4 bridge (19.0mm string spacing)
- USA Bartolini® Custom neck pu
- USA Bartolini® Custom bridge pu
- PWC III 3-band eq
- Elixir® strings
- Hardware color : Cosmo Black
- Scale : 864mm/34"
- Colors : NT (Natural)
DE (Deep Espresso)

SR4505E NT

- 5pc Atlas-5 HP Maple/Bubinga neck *Prestige* w/KTS™ TITANIUM Reinforcement
- BLACK TUSQ XL™ NUT
- Ash body
- Medium frets
- MR-4 bridge (16.5mm string spacing)
- USA Bartolini® Custom neck pu
- USA Bartolini® Custom bridge pu
- PWC III 3-band eq Elixir® strings
- Hardware color : Cosmo Black
- Scale : 864mm/34"
- Colors : DE (Deep Espresso) NT (Natural)

SR4000E SDR

- 5pc Atlas-4 HP Wenge/Bubinga neck *Prestige* w/KTS™ TITANIUM Reinforcement
- BLACK TUSQ XL™ NUT
- Mahogany body
- Medium frets
- MR-4 bridge (19.0mm string spacing)
- USA Bartolini® Custom neck pu
- USA Bartolini® Custom bridge pu
- PWC III 3-band eq
- Elixir® strings
- Hardware color : Cosmo Black
- Scale : 864mm/34"
- Colors : SDR (Stained Red)
TKF (Transparent Black Flat)

SR4005E TKF

- 5pc Atlas-5 HP Wenge/Bubinga neck *Prestige* w/KTS™ TITANIUM Reinforcement
- BLACK TUSQ XL™ NUT
- Mahogany body
- Medium frets
- MR-4 bridge (16.5mm string spacing)
- USA Bartolini® Custom neck pu
- USA Bartolini® Custom bridge pu
- PWC III 3-band eq • Elixir® strings
- Hardware color : Cosmo Black
- Scale : 864mm/34"
- Colors : SDR (Stained Red)
TKF (Transparent Black Flat)

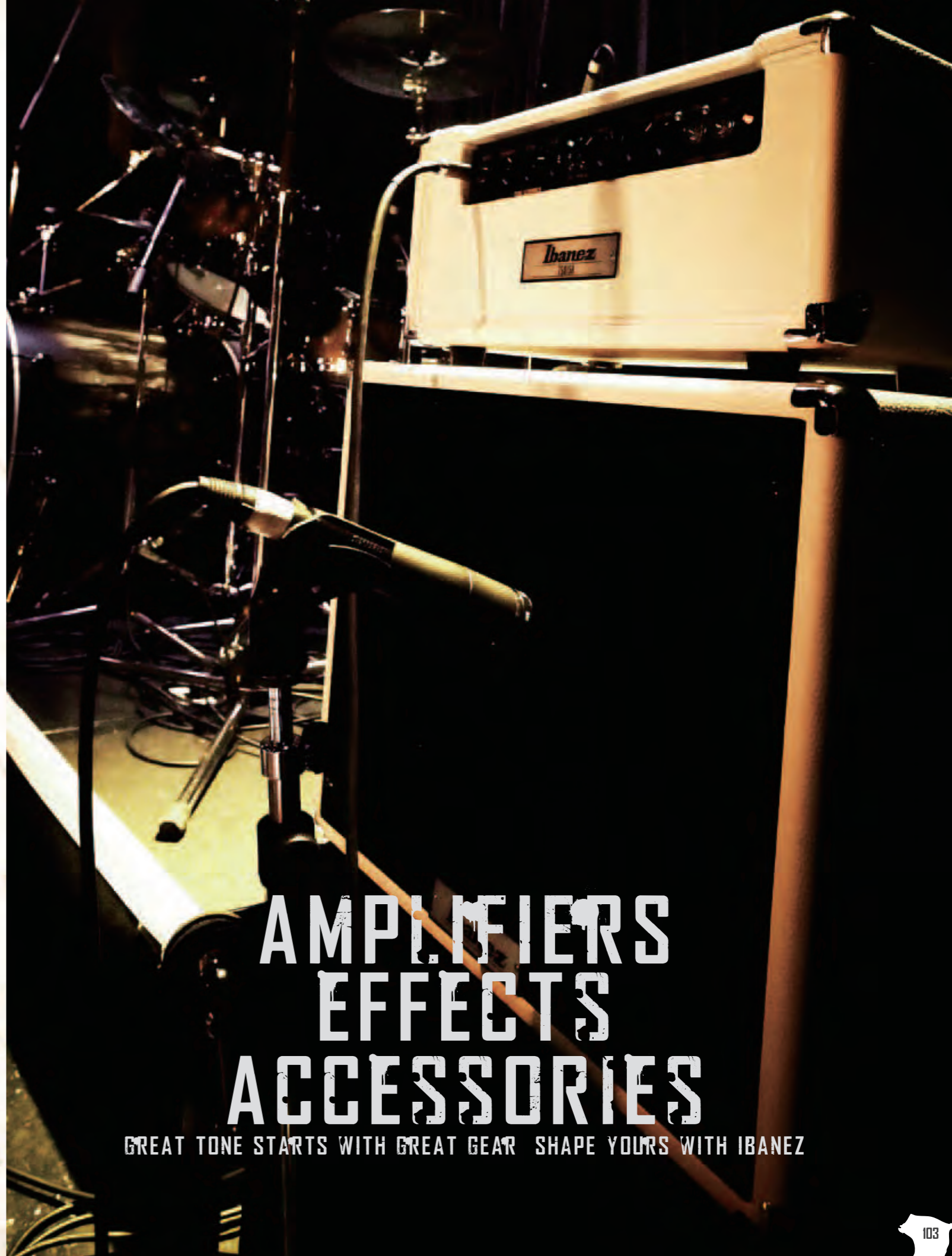

AMPLIFIERS EFFECTS ACCESSORIES

GREAT TONE STARTS WITH GREAT GEAR SHAPE YOURS WITH IBANEZ



Boost Switch

Turning the boost switch on increases gain by 6dB. This function gives players a thicker Tubescreamer sound.



Tone Control

The tone control gives players access to the natural clean sound and biting crunch only possible with tube amps. A simple 2-band control is provided.



Wattage Selection

Switching between 15W and 5W mode is possible using the output mode switch located on the back of the amp. Running the amp at 5W will allow you run the amp hotter while maintaining a reasonable volume.

TUBE SCREAMER AMPLIFIER

For all the warm tube overdrive punch and crunch you'll ever need!

The Ibanez TUBESCREAMER is one of the best overdrive pedals ever produced. The TSA15H tube amp features a true TUBESCREAMER circuit, and while the TSA112C speaker cabinet is designed to match the TSA15H, featuring the popular CELESTION Seventy 80 speaker. Ibanez TUBESCREAMER amps can create natural clean sounds, fat crunch tones, and even warm smooth overdrive tones with the modified TS9 circuit built right into the amp.

TSA15H

Guitar Amplifier Head

- output power 15W/5W
- controls Boost/Normal Switch, Tubescreamer On/Off Switch, Master Volume, Bass, Treble
- i/o's Tube Screamer Section: Overdrive, Tone, Level; Guitar Input, Foot Switch Jack, Effect Loop (Send/Return); Speaker Output (2x4ohm, 2x8ohm, 1x16ohm)
- size 14.5"(W) x 6.8"(D) x 7.9"(H)
- weight 16.8 lbs

TSA112C

Speaker Cabinet

- power handling 80W
- speaker 12" Celestion Seventy80
- i/o's Input 8Ω
- size 18.1"(W) x 12.0"(D) x 16.1"(H)
- weight 28.7 lbs



IFS2G

Footswitch

This latching footswitch with green housing is made especially for the TSA15H.



The Ibanez Tube Screamer has long been the name people think of first when it comes to overdrive. The TSA15H comes equipped with this legendary circuit built right into the front end so players can enjoy this warm, smooth overdrive anytime they want.



Tone Blaster

The new generation Tone Blaster X series amps were designed and created to answer the needs of today's guitarist. The parametric mid EQ allows you to dial in any tone you're looking for in an instant. The exclusive X mode allows you to get monstrously heavy and lets you cut through the din of the loudest rhythm section. The gain control in the normal channel can be dialed down to give you anything from a clean jazz tone to a crunchy, slightly overdriven rock'n roll tone. Plug in and express yourself with TBX.



TBX150H

150W Guitar Amplifier

- output power 150W@4Ω
- controls Normal Channel - Overdrive Switch, Gain, Bass, Middle, Treble, Volume, Reverb Level; Hot Channel - X Mode Switch, Gain, Bass, Middle Frequency, Middle Level, Treble, Volume, Reverb Level, Channel Switch, Hue
- i/o's Input, Send, Return, 2 x Speaker Output, Footswitch 1 & 2
- cabinet W/Accessory Box
- size 25.0"(W) x 9.9"(D) x 10.2"(H)
- weight 31.1 lbs

IS412CS

Speaker Cabinet

- speaker unit 4 x 12" Ibanez IS1216G
- power handling 320Wrms/640Wmax
- i/o's 2 x Input (4Ω&16Ω)
- cabinet IS412CA: Traditional Angled; IS412CS: Straight Front Angled
- size 27.8"(W) x 13.1"(D) x 29.7"(H)
- weight 75.1 lbs

*Also Available IS412CA w/Angled Front



X MODE/CHANNEL

The X mode/channel emphasizes tighter low end and a unique tonality in the midrange, which increases sustain and harmonics.



TBX30R

30W Guitar Amplifier

- output power 30W@8Ω
- speaker unit 10" Ibanez IS1008G
- controls Normal Channel - Gain, Volume, Channel Switch; X Channel - Gain, Volume; EQ - Bass, Middle Frequency; Middle Level, Treble, Reverb Level
- i/o's Input, CD/MP3 In, Footswitch, Headphones
- cabinet Open Back Cabinet
- size 17.3"(W) x 8.7"(D) x 16.3"(H)
- weight 18.3 lbs



TBX65R

65W Guitar Amplifier

- output power 65W@4Ω
- speaker unit 12" Ibanez IS1204G
- controls Normal Channel - Overdrive Switch, Gain, Bass, Middle, Treble, Volume, Channel Switch; Hot Channel - X Mode Switch, Gain, Bass, Middle Frequency, Middle Level, Treble, Volume, Reverb Level
- i/o's Input, CD/MP3 In, Footswitch, Headphones
- cabinet Closed Back Cabinet
- size 19.3"(W) x 10.0"(D) x 17.8"(H)
- weight 39.1 lbs



TBX150R

150W Guitar Amplifier

- output power 150W@4Ω
- speaker unit 2 x 12" Ibanez IS1208G
- controls Normal Channel - Overdrive Switch, Gain, Bass, Middle, Treble, Volume, Reverb Level; Hot Channel - X Mode Switch, Gain, Bass, Middle Frequency, Middle Level, Treble, Volume, Reverb Level, Channel Switch, Hue
- i/o's Input, Send, Return, Speaker Output, Footswitch 1 & 2
- cabinet Closed Back Cabinet
- size 26.3"(W) x 10.8"(D) x 19.7"(H)
- weight 54.1 lbs

wholetone

The Ibanez WT80 was made to provide clean tone at a loud level. With a 15" speaker pumping 80W of power this amp does just that. A DSP-based precision limiter ensures your sound will stay clean even at a high volume.



WT80

Guitar Amplifier

- output power 80W@4Ω
- speaker unit Special Tuned 15" Speaker
- controls Gain, Bass, Mid, Treble, Tone, Master-Volume, Aux-Volume, Chorus, Reverb
- i/o's Input, Aux Input, Headphones Out with Stereo FX
- cabinet Ported Cabinet
- size 17.3"(W) x 14.4"(D) x 19.7"(H)
- weight 38.8 lbs



Chorus and Reverb Effects

Chorus and reverb controls allow you to add depth and space to your sound. The Aux inputs separate volume control allows you to blend just the right amount of backing tracks with ease.



3 band EQ

Aside from its 3 band EQ, an additional tone control allows you to adjust the overall tonal character of the amp.

Sound Wave

No matter what wattage is called for, the new line of Ibanez Soundwave Bass Amps has it covered. A tilt-back design puts the amp at just the right angle and is perfect for practicing, whether your sitting or standing you will have no problem hearing yourself. A built in limiter provides precise control to prevent unfavorable distortion. Whether its power, portability, or both, the new line of Soundwave Bass Amps has every bass player covered.

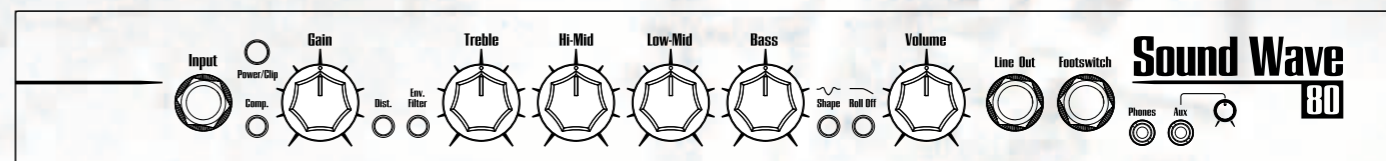

Effects

SW amps feature an envelope filter for creating unique sounds, analog distortion that has been optimized for use with basses, and a compressor. Both the envelope filter and distortion can be controlled using a footswitch. Both mid-shape and roll-off controls are included with SW amps.



IBZ

These Ibanez practice amps provide players with full-on guitar and bass sound.



IBZ15GR

15W Guitar Amplifier

- output power 15W @ 4Ω
- speaker unit 8" Speaker
- controls Normal Channel - Volume, Channel Switch, Distortion Channel - Gain, Volume, Bass, Middle, Treble, Reverb
- i/o's Input, Aux Input, Headphones Out
- cabinet Closed back
- size 14.0"(W) x 8.3"(D) x 13.4"(H)
- weight 13.5 lbs

With a high output of 15W and an 8" specialized speaker, the IBZ15GR provides an intense sound. In addition to full-fledged distortion, a control for reverb has also been added.



IBZ10G

Guitar Amplifier

- output power 10W@8Ω
- speaker unit 6.5" speaker
- controls Overdrive On/Off Switch, Gain, Bass, Treble, Volume
- i/o's Guitar Input, Headphone, CD Input
- cabinet Closed Back
- size 10.8"(W) x 7.9"(D) x 12.3"(H)
- weight 11.7 lbs

This amp reproduces a heavy sound using a closed-back cabinet and a 6.5" Power Jam speaker. It comes with simple Bass / Treble control for producing various tones as well as a CD input.



IBZ10B

Bass Amplifier

- output power 10W@8Ω
- speaker unit 6.5" speaker
- controls Bass, Middle, Treble, Volume
- i/o's Bass Input, Headphone
- cabinet Closed Back
- size 10.8"(W) x 8.1"(D) x 12.3"(H)
- weight 11.3 lbs

The IBZ10B features a closed-back cabinet and 6.5" Power Jam speaker for producing real bass sound. The 3-band EQ allows players access to a variety of sounds, and the amp also comes with a CD input.

SW35

Bass Combo Amplifier

- output power 35W @ 8Ω
- speaker unit 10" Coaxial Speaker
- controls Gain, Bass, Low-Middle, High-Middle, Bass, Middle, Treble, Volume, Compression Switch, Shape Switch, Roll Off Switch, Distortion Switch (Footswitchable), Envelope Filter Switch (Footswitchable)
- i/o's Input, Aux Input, Line Out, Headphones Out, Footswitch Jack
- cabinet Tilt-back, Closed
- size 17.5"(W) x 13.8"(D) x 17.3"(H)
- weight 30.7 lbs

SW15

Bass Combo Amplifier

- output power 15W @ 8Ω
- speaker unit Special Tuned 10" speaker
- controls Bass, Middle, Treble, Volume
- i/o's Input, Aux Input, Headphones Out
- cabinet Tilt-back, Closed
- size 13.4"(W) x 11.0"(D) x 14.6"(H)
- weight 15.2 lbs

SW80

Bass Combo Amplifier

- output power 80W @ 4Ω
- speaker unit 15" Speaker with Piezo Tweeter
- controls Gain, Bass, Low-Middle, High-Middle, Treble, Volume, Compression Switch, Shape Switch, Roll Off Switch, Distortion Switch (Footswitchable), Envelope Filter Switch (Footswitchable)
- i/o's Input, Aux Input, Line Out, Headphones Out, Footswitch Jack
- cabinet Tilt-back, Ported
- size 21.3"(W) x 15.7"(D) x 21.7"(H)
- weight 44.6 lbs

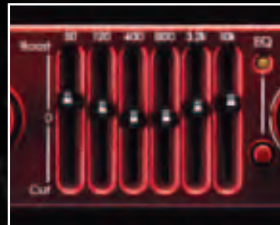

6 Band Graphic EQ

Promethean series amps feature 6-band Graphic EQ that allows you to make precise tonal adjustment in any type of environment. Each frequency is carefully selected to be the most demanded by bass players. The 6-band EQ can be bypassed by a selected switch.



Vibe Control

Control tonal character from creamy vintage sounds to modern sounds. Also, the On/Off push switch allows you to change playing character, from walking to picking and/or slapping, instantly. (On/Off can be controlled by optional IFS2X footswitch.)

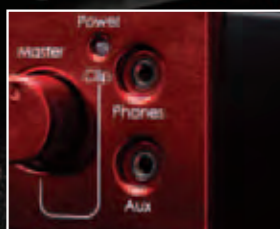

Aux/Phones

The included aux input allows you to play along with a connected MP3 or CD player. With headphone out, it's great for bedroom jam sessions or sound check at rehearsal.



Line Out

The balanced XLR output sends a balanced signal to the mixing console and/or main PA system in any live or studio situation. Pre- or Post EQ switchable and GND Lift switch-equipped along with switchable level control to avoid ground loops with other connected equipment.

SPEAK LOUD AND CARRY A SMALL AMP

promethean

IBANEZ BASS AMPLIFIERS

One might never imagine that a small amp could produce big sound, but in terms of the Ibanez Promethean Bass amp series, that is not the case. The Promethean series amp is designed for busy working musicians who travel around from one venue to the next. Within its compact body, the Promethean features CRITICAL functions in order to deal with various situations and requirements in a live environment. It also gets LOUD!!! The working musician has it easy with the Promethean amp, a dependable workhorse of an amp.



Detachable Amp Head (P5110/P5115K/P5210)

The amp head can be easily detached without any tools. Due to its compact size, it's efficient to take it out anywhere you need to go.

P5110

Bass Combo Amplifier

- output power 250W@8Ω/500W@4Ω
- speaker unit 10" Ceramic Speaker, Dome Tweeter
- controls Mute Switch, Gain, Low/High Control, 6 Band Graphic EQ, Vibe Control, Master Volume
- i/o's Input, Aux Input, Phones Out, Tuner Out, Balanced Line Out (XLR), Footswitch Jack (Mute/Vibe)
- cabinet Ported cabinet w/Tilt-up bar
- size 12.8"(W) x 13.1"(D) x 14.2"(H)
- weight 27.6 lbs

The P5110 delivers 250W@8Ω while using individually. Along with the P110C speaker cabinet, it delivers 500W@4Ω in total.



P5210

Bass Combo Amplifier

- output power 500W@4Ω
- speaker unit 2 x 10" Ceramic Speaker, 2 x Dome Tweeter
- controls Mute Switch, Gain, Low/High Control, 6 Band Graphic EQ, Vibe Control, Master Volume
- i/o's Input, Aux Input, Phones Out, Tuner Out, Balanced Line Out (XLR), Footswitch Jack (Mute/Vibe)
- cabinet Ported
- size 13.1"(W) x 14.2"(D) x 30.3"(H)
- weight 54.7 lbs

A bass combo amplifier with 2 x 10" speakers and 500W. It performs perfectly in any situation regardless of the venue, from a small pub to a larger club situation. The head is detachable from cabinet, so you can carry it around and use just the head.



IFS2X

Footswitch

Latching footswitch with metal housing for use with the P500H and P5110. (The IFS2X is not included and is sold separately.)



P500H

Bass Amplifier Head

- output power 250W@8Ω/500W@4Ω
- controls Mute Switch, Gain, Low/High Control, 6 Band Graphic EQ, Vibe Control, Master Volume
- i/o's Input, Aux Input, Phones Out, Tuner Out, Balanced Line Out (XLR), Footswitch Jack (Mute/Vibe)
- size 11.0"(W) x 10.4"(D) x 2.2"(H)
- weight 6.4 lbs

BGP500

Carry Bag

Bag for P500H. (The BGP500 is not included and is sold separately.)



P5115K

Bass Combo Amplifier

- output power 500W @ 4Ω
- speaker unit 15" Speaker w/Horn Tweeter
- controls Same as P500H
- i/o's Same as P500H
- Cabinet Tilt-back, Ported
- size 18.7"(W) x 15.7"(D) x 20.5"(H)
- weight 39.9 lbs

This 500W combo bass amp comes equipped with a specially tuned 15" speaker and a horn tweeter. A tilt-back style cabinet allows you to monitor your sound with ease.



P115CC

Speaker Cabinet

- 250W
- 15" Speaker
- Horn Tweeter
- 1/4" jack x2
- Ported cabinet
- 24.4"(W) x 15.7"(D) x 18.5"(H)
- 54.0 lbs



P410CC

Speaker Cabinet

- 250W
- 4x10" Speaker
- Horn Tweeter
- 1/4" jack x2
- Ported cabinet
- 25.6"(W) x 15.7"(D) x 25.6"(H)
- 73.2 lbs



P110C

Speaker Cabinet

- 250W
- 10" Neodymium Speaker
- Dome Tweeter
- SPEAKON® Combo Jack
- Ported cabinet w/Tilt-up bar
- 12.8"(W) x 12.8"(D) x 18.1"(H)
- 21.0 lbs



P210KC

Speaker Cabinet

- 250W
- 2 x 10" Speaker
- Horn Tweeter
- 1/4" jack x2
- Tilt-back, Ported cabinet
- 24.4"(W) x 15.0"(D) x 18.3"(H)
- 49.2 lbs

*SPEAKON® is a registered trademark of Neutrik AG

9series

Sometimes it's best to keep it simple. Which is why, in a world of dizzying often over-complex technology, the durable, dependable and simple stompbox continues to be the most widely used and effective means to expand, color, distort, mutate, sustain and twist tone.



BB9 Booster

The Ibanez BB9 is a booster that provides a fat bottom end and a powerful sound. This pedal is designed to help clean tones reverberate even more and bring more intensity to a player's sound. Combination with a distortion pedal allows for creation of a wide variety of tone colors, and the pedal is also equipped with True Bypass.



JD9 Distortion

The Ibanez JD9 produces a unique sound reminiscent of a high-grade handcrafted effects pedal. From piercing distortion to the warm crunch of a tube amp, this pedal features a wide variety of drive control options. The mid control is capable of producing a vast range of sounds from American hard rock to British heavy metal. The pedal is also designed with True Bypass to keep changes in sound when the pedal is off to a minimum.



TS9B Bass Tubescreamer

The TS9B is equipped with controls to allow bassists to produce the sound they want while still maintaining the feel of the Tubescreamer. Experimenting with the mix and tone controls allows for creation of a limitless number of sounds. Players can get a tight, fuzzy sound with mix control or a mid-scooped, funky sound with 2-band control.



TS808HW Hand-Wired Tubescreamer

Encased in a special, heavy duty metal box, the TS808HW is Hand-Wired with select JRC4558D chips (same as the revered and often imitated TS808). Equipped with True Bypass, this Tubescreamer sends pure guitar excitement to your amplifier with no tonal loss whatsoever. This is, by far, the most evolved Tubescreamer ever created.



TS808 The Original Tubescreamer

Modeling and boutique pedal makers have copied the smooth and full tone of this pedal countless times. Now you can have Ibanez's faithful reissue at a price that doesn't break the bank. The reissue features the same JRC4558D IC chip and analog circuitry as the original. Controls include overdrive, level, and tone controls.



TS9DX Turbo Tubescreamer

The Ibanez TS9DX Turbo Tubescreamer Effects Pedal features the same circuit as a TS9 Tubescreamer and also offers 3 new settings for increased low end crunch: +, Hot, and Turbo.



TS9 Tubescreamer

The Ibanez TS9 Tubescreamer is a reissue that's just like the original in so many ways. Same factory, same components, same housing, same famous seasick-green paint, and the same crankin' overdrive that made the original one of the all-time classic pedals. Guitar Player called it the best. Plug it in. Crank it up. You'll hear what all the fuss is about. Tone, drive, and level controls.

TUBE KING

While the tube in many 9-volt tube-overdrive pedals merely functions like a filter, the TK999 Tube King and its crown jewel 12AX7 tube get genuine high voltage, just like a tube preamp. The result? The Tube King can make any solid-state amp sound just like a tube amp, with massive, tight overdrive/distortion.

TK9990D Tube King Overdrive

Genuine High Voltage Tube Overdrive
3 band EQ with presence
Gain and level controls
Hi/Lo input switch
AC Adapter included



TK999HT Tube King Distortion

Genuine High Voltage Distortion Pedal
Actual 12AX7 Tube
Active EQ plus Presence Switch
VOID Control
AC Adapter included



Range switch : Guitar 350Hz - 2.2kHz
Bass 175Hz - 1.1kHz
Depth control : +6 - +12dB

WEeping Demon

WD7JR Weeping Demon Junior

A more affordable version of our WD7 pedal, the WD7JR presents a high quality wah-wah pedal at a great price. Activates with minimal pedal pressure. Auto Off Delay control allows you to delay the end of wah-wah effect after your foot leaves the pedal, for smooth transition and phrasing. Features a maintenance-free optical sensor - no need to worry about producing unwanted noise from the volume pot. Also includes Level control for volume adjustment.



WD7JR/Auto-Off Delay



Adjusts the time delay from when the pedal is returned until the effect switches off. Turning this clockwise will increase the time delay, preventing the effect from turning off while you are operating the pedal. Turning this counterclockwise will make the effect turn off more quickly, so that it will turn off immediately when you return the pedal.

WD7 Weeping Demon

The Ibanez WD7 Weeping Demon Wah Pedal will have your audience screaming for more with its shrieks, cries, wails, and seductive siren songs. Among its features are spring and normal footboard action, selectable wah range, and fine tuning controls.



WD7/Auto-Off Delay

In the AUTO SWITCH mode, you can set the effect-off either on standard instant off when the pedal is returned to the full upright position or a delayed-off by turning the control clockwise.



WH10V2

WH10V2 Classic Wah Pedal

The upgrade you will notice is the die-cast metal construction, replacing the original plastic case. Feel free to dance on this sucker now—it can take anything you dish out.

The WH10V2 features the same multiple feedback opamp circuit as the original, a feature rarely found in today's wah pedals. It also has a depth knob to control to level of the wah effect and a dry out for mixing a dry signal with the wah sound. The WH10V2 has a unique tone character setting it apart from all traditional wah pedals, as well as some modern tweaks so your sound keeps changing with the times.



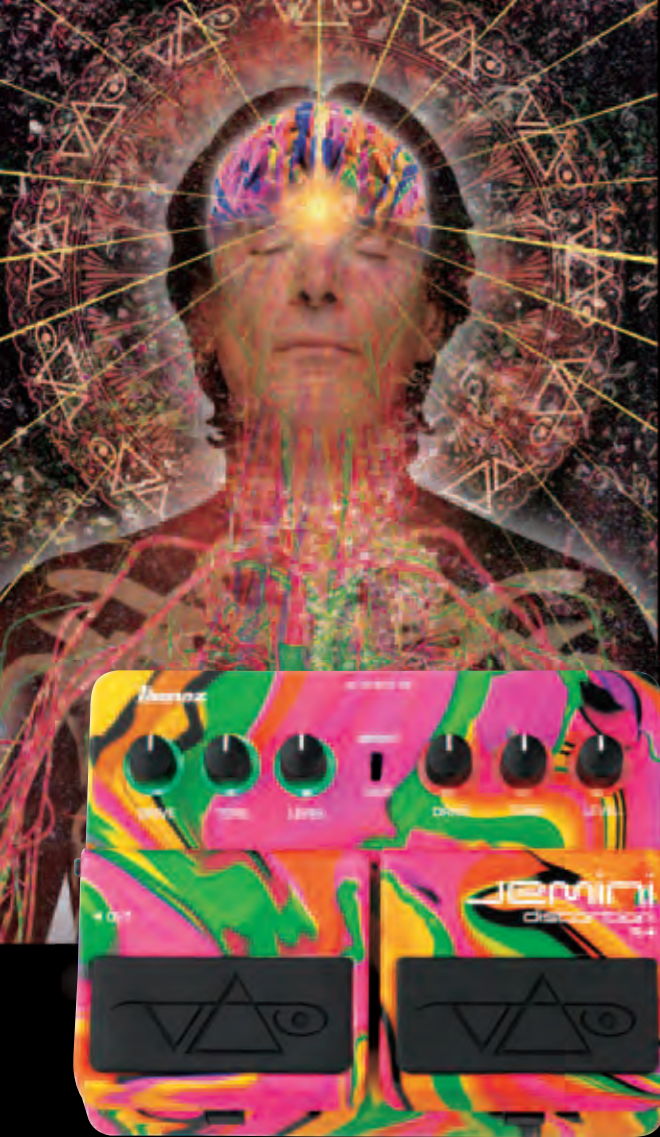

Jemini

dual distortion reality

Steve Vai's Signature Distortion Pedal with overdrive and distortion in one package. Featuring a rigid aluminum case, magnificent LED lights around the knobs, and a unique multicolor case with Vai logo rubber foot pedals. The JEMINI's meant to be seen and heard.

- JEMINI** - Steve Vai Signature Distortion "JEMINI" -
- controls Distortion A / B, DRIVE, TONE, LEVEL
 - switch LED BRIGHT/SAVE
 - i/o's INPUT / OUTPUT
 - power source Operates with a DC 9V AC Adapter or 9V Battery

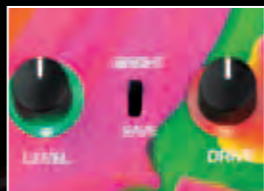

LED Lit Controls
Each side includes drive, tone and level controls with LED indicators around each control and a LED bright/save control switch for daytime use or saving the battery.



Steve Vai Signature Foot Pedals
Steve's trademark logo is imprinted on the Jemini's foot switches.

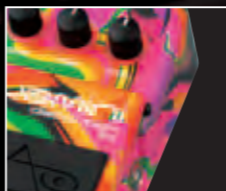

Heavy Duty Aluminum Housing
The housing is finished off with Steve's infamous trademark swirl paint job.

AIRPLANE FLANGER

Paul Gilbert Signature Pedal Effect Flanger

The Paul Gilbert Signature AF2 AIRPLANE Flanger is two pedals in one package. One section is a traditional chorus flange (TAXI); the other is an insane (TAKEOFF) flange (hence the "AIRPLANE" moniker), which provides virtuoso guitarist Paul Gilbert's own "Crazy Flange" sound. Time to buckle up. The AF2 features Manual (delay time), Speed (modulation speed), Range (depth of modulation), and Enhance (feedback) controls.

- AF2** - Paul Gilbert Signature Flanger "AIRPLANE FLANGER" -
- controls TAXI : Flange/Chorus Type Modulation Effect
TAKEOFF : Jet Sound (shifting pitch up and down)
MANUAL : Delay Time,
SPEED : Modulation Speed,
RANGE : Depth of Modulation
ENHANCE : Feedback,
EFFECT ON/OFF Switch,
TAXI/TAKEOFF Switch
INPUT/OUTPUT (Mono)
Operates with a DC 9V AC Adapter
 - i/o's
 - power source



TUNERS

When you make 6-string, 7-string and 8-string guitars for players who use all kinds of alternate tunings, you'd better be very serious about tuning. We are. Our wide variety of compact tuners offer strict accuracy, easy operation and our famous Ibanez reliability.

CABLES

Series DS Low Noise Cable

- 10-year replacement warranty.
- "Basic" in price only.
- DS cable offers pro-quality and durability at standard cable prices.
- Double-shielded construction.



Series STC Standard Cable

- 10-year replacement warranty.
- "Basic" in price only.
- Low Noise.



# Item	Specifications	
DSC10BK	10' Woven Cable	10'/2 Straight Plugs
DSC10RD	10' Woven Cable	10'/2 Straight Plugs
DSC10BL	10' Woven Cable	10'/2 Straight Plugs
DSC20BK	20' Woven Cable	20'/2 Straight Plugs
DSC20RD	20' Woven Cable	20'/2 Straight Plugs
DSC20BL	20' Woven Cable	20'/2 Straight Plugs
SPCPP6	6' Speaker Cable	6'/2 Straight Plugs
SPCPP10	10' Speaker Cable	10'/2 Straight Plugs
SPCPP25	25' Speaker Cable	25'/2 Straight Plugs
SPCPP50	50' Speaker Cable	50'/2 Straight Plugs
MCCC10	10' Microphone Cable	10'/2 XLR Plugs
MCCC20	20' Microphone Cable	20'/2 XLR Plugs
MCCC50	50' Microphone Cable	50'/2 XLR Plugs
STC05LL	0.5' Cable	0.5'/2 Right Angle Plugs
STC08LL	0.8' Cable	0.8'/2 Right Angle Plugs
STC6	6' Cable	6'/2 Straight Plugs
STC10	10' Cable	10'/2 Straight Plugs
STC10L	10' Cable	10'/Straight & Right Angle Plugs
STC15	15' Cable	15'/2 Straight Plugs
STC15L	15' Cable	15'/Straight & Right Angle Plugs
STC20	20' Cable	20'/2 Straight Plugs
STC20L	20' Cable	20'/Straight & Right Angle Plugs
STC25	25' Cable	25'/2 Straight Plugs
STC25L	25' Cable	25'/Straight & Right Angle Plugs

LU30

Pedal Tuner

This tuner features aluminum die-cast housing as well as an easily visible LED display. We put a high priority on creating an easy to see display in a compact size tuner. It fits perfectly even in the limited space available on effects boards. One output of the LU30 is muted when it is turned on.

CU1

Chromatic Tuner

The GU1 is the first guitar / bass auto tuner with strobe displaying mode. In needle displaying mode, the meter moves the same as the tuner ever. In strobe displaying mode, the meter goes round and tune. The operation is very simple even for beginners. CU1 also has manual tuner mode. The operation is very simple even for beginners.

GU40 BL

GU40 RD

GU40 SL



GU40

Automatic Tuner

The colorful GU40 guitar tuner from Ibanez features hands-free tuning. This no hassles auto tuner is fast and accurate and works with guitar, bass or almost anything that shares the same tuning. It even has seven tuning notes for 7-string guitars. The GU40 guitar tuner has a built-in mic for fast and accurate metering.

PU20

Clip Tuner

PU10

Both Ibanez clip tuners, PU20 and PU10, are designed to tune electric and acoustic guitars, basses, violins, banjos, mandolins, and more without interference from ambient room noise. It does it all without the use of wires, microphones or pickups. Tuning in noisy environments is a snap because the unique, flexible clamp actually feels the instrument's vibration instead of relying on sound. PU20 features backlit large LCD display for maximum visibility even in the dark stage. PU10 features the 4 hinges that allow a perfect view of the tuner's LED display from nearly any angle. * Black and Silver colors are available in PU10.



LU10

Chromatic Tuner

This tuner is designed for electric guitars and basses, as well as acoustic guitars. The clever LU10 is an easy-to-use tuner with an LED display including a large, bright note display. It's very easy to work with.

GU1 SL

GU1

GU1

Automatic Tuner

CU40

Chromatic Tuner

The CU40 chromatic guitar tuner from Ibanez is fast and accurate and works with guitar, bass or almost anything else. The CU40 has a large LCD display, LED 'flat' and 'sharp' guide lights and a built-in mic for fast and accurate metering.

MU40

Metronome Tuner

The dual purpose Ibanez MU40 Tuner/Metronome indicates pitch with both an LCD needle display plus red flat and sharp LEDs plus a green in-tune LED. Designed for electric guitars, basses and acoustic instruments. Built-in metronome with speaker, mute switch, and headphone input. Ideal for teachers and students.

PU10SL

PU10

PU20

CASES AND GIG BAGS

Only Ibanez cases and bags are made to fit the unique shapes of Ibanez guitars and basses. If it doesn't say Ibanez on the case or bag, it's not an Ibanez.



UV1000C

M100C

RG140C



ATK1000C

EXB1000C

MB100C

Guitar Case Item #	Models
UV1000C	for RG, RGA, RGD 6-strings, GRG, GRGA
M100C	for RG, RGA, RGD 6-strings, GRG, GRGA, S, SA, GSA, JS
RG550LC	for RG, RGA, RGD 6-strings, GRG, GRGA, S, RG left handed
RG140C	for RG, RGA, RGD, GRG, GRGA, GRX, GSA
XP100C	for XP
AR100C	for ARZ, ARX, ART, GART, GART left-handed
ICT100C	for ICT
NDM1000C	for NDM2
W50DNT	for DN
DTT100C	for DTT

Box Guitar Case Item #	Models
AF100C	for AF, AK
AF200C	for AF, AK
AG100C	for AG, AGR
AFS100C	for AGS
AM100C	for AM, AMF
AS100C	for AS, AFS
AS200C	for AS, AFS
GB10SC	for AG, GB

Bass Case Item #	Models
MB100C	for SR, SRX, SRT, SRA, MDB
EXB1000C	for SR, SRX, SRT, SRA, MDB, GSR
ATK1000C	for ATK, BTB, PGB
ICB100C	for SDB
JTKB100C	for GARTB
AGB100C	for AGB
AFB100C	for AFB



AGB100C



PT32 Guitar/Bass Stand

PICKS



PAUL GILBERT

SAND GRIP WIZARD

STEVE VAI

RUBBER GRIP WIZARD

STANDARD ART PICKS

STANDARD CELLULOID

Ibanez picks feature traditional styles, artist signature models and special no-slip "Grip Wizard" picks.

Signature Picks	Item #	Color	Thickness	Material
Steve Vai	B1000SV	Brown/Green/Pink	HEAVY	POLYACETAL
Steve Vai	B1000SVR	White	HEAVY	POLYACETAL
Paul Gilbert	B1000PG	Black/Candy Apple*/Jewel Blue/Pearl White	HEAVY	CELLULOID *PVC

Series	Item #	Color	Thickness	Material
Sand Grip Wizard	BPA16HS	Black/Blue/Red/White	HEAVY	POLYACETAL
	BPA16MS		MEDIUM	
Rubber Grip Wizard	BPA16HR	Black/Blue/Red/White	HEAVY	POLYACETAL
	BPA16MR		MEDIUM	
Standard ART Picks	BTL16H	Black/Orange or Red*/Clear/Green/Blue/White	HEAVY	CELLULOID *PVC
	BTL16M		MEDIUM	
	BIB16H		HEAVY	
	BIB16M		MEDIUM	
	BCI16H		HEAVY	
	BCI16M		MEDIUM	
Standard Celluloid	BCE16H	Black/Hair-lined Gold/Tortoiseshell/White	HEAVY	CELLULOID
	BCE16M		MEDIUM	
	BCE4T	Pearl/Tortoiseshell	THIN	

Standard Bags

Comfortable strap angle, thick shoulder pad and waist belt all combine to make your gear feel lighter than ever.

ISGB501	Bag for El. guitar
ISBB501	Bag for El. bass



IDGB5/Double Gig Bag

- Carries two axes
- Includes wheels
- Able to stand independently



IDBB5/Double Gig Bag

- Carries two basses
- Includes wheels
- Able to stand independently



BBP Bass Gig bag
Combination bag features a separable backpack and heavy-padded gig bag.



GBP Guitar Gig bag



IBB7 Deluxe Bass Gig Bag
• Includes slide-out laptop bag



GBMIKRO
Mikro Guitar Bag



BGBMIKRO
Mikro Bass Bag



IGB7 Deluxe Guitar Gig Bag
• Includes slide-out laptop bag

STRAPS

Heavy duty combination cloth/leather Ibanez straps offer a 70" maximum length.



GS60CIBR
GS60CISL
GS60STGY
GS60STRD

GS61L WH
GS61L BR
GS61L GY
GS61L BK



IS5BK

LS65TLBKS

LS65TLBRE

LS65TLWHD

PICKUP SPECIFICATIONS

MODEL NO.	NAME	RECOMM. POSITION	CONSTRUCTION	MAGNET	DESCRIPTION KEY
					RECOMMENDED POSITION B : BRIDGE, M : MIDDLE, N : NECK
					CONSTRUCTION H : HUMBUCKING, S : SINGLE COIL BASS ONLY/A : ACTIVE, P : PASSIVE
					MAGNET AL : ALNICO, C : CERAMIC
IBANEZ GUITAR PICKUPS					
ACH-BL	ACH-BL	B	H	C	Single coil sized blade humbucking pickup. Sound in-between humbucking and single coil.
ACH1	ARTCORE 1	N	H	C	Clean sounding with a slight overdrive
ACH2	ARTCORE 2	B	H	C	Bridge version of ACH1.
ACH1-M	ARTCORE 1 Mini	N	H	C	Warm, bright and dry sound
ACH2-M	ARTCORE 2 Mini	B	H	C	Warm, bright and dry sound
ACH3-M	ARTCORE 3 Mini	N	H	C	Warm, versatile and crunchy sound.
ACH4-M	ARTCORE 4 Mini	B	H	C	Warm, versatile and crunchy sound.
ACH1-S	ACH1-S	N	H	C	Tight tone with added treble.
ACH2-S	ACH2-S	B	H	C	Bridge version of ACH1-S.
AH1	AXIS HUMBUCKER	N	H	C	Very responsive and full sounding; medium output with lots of character. Excellent for chording.
AH2	AXIS HUMBUCKER 2	B	H	AL	Full bass sound. Alnico-5 magnet provide excellent clarity in harmonics and individual notes.
AH1-7	AXIS HUMBUCKER 1-7	N	H	C	Seven-string version of AH1 pickup.
AH2-7	AXIS HUMBUCKER 2-7	B	H	C	Seven-string version of AH2 pickup.
AH3-7	AXIS HUMBUCKER 3-7	N	H	C	For 7 strings, responsive, maintains clarity.
AH4-7	AXIS HUMBUCKER 4-7	B	H	C	Balanced tone with enough power for 7 strings
AHS1	AXIS SINGLE 1	N	S	AL	Traditional sounding single coil pickup with increased output for neck position.
AHS2	AXIS SINGLE 2	M	S	AL	Traditional sounding single coil pickup with increased output for center position.
CAP-LZ10	CAP-LoZ	N	H	AL	Active Pickup. High-output yet low noise, with rich tone in mid range.
CAP-LZ20	CAP-LoZ	B	H	C	Active Pickup. High-output yet low noise. The tone was designed with detailed intensity, incredible amounts of middle range with rich tone and fluid sustain.
CAP-VK1	CAP-VK1	N	H	C	Neck version of CAP-VK2.
CAP-VK2	CAP-VK2	B	H	C	High output. Specially designed for down-picking. Having a clarity not only in clean sound but also with distortion, for extended low end and serious treble response for single-note solos.
CAP-VK17	CAP-VK17	N	H	C	Neck version of CAP-VK27.
CAP-VK27	CAP-VK27	B	H	C	CAP-VK2 adjusted for 7 strings.
CAP-VM1	CAP-VM1	N	H	AL	Minimum sound loss by adopting OFC coil. Clean and warm, but never restrained. Also offers rich harmonics without distorted.
CAP-VM1S	CAP-VM1S	M	S	AL	Minimum sound loss by adopting OFC coil. Bright and clear single coil tone, yet not thin.
CAP-VM2	CAP-VM2	B	H	AL	Minimum sound loss by adopting OFC coil. High output, yet offers dynamic range for great response maximizing the nuance of picking. Retired low-end making the total sound bigger.
CAP-CCR1	CAP-CCR1	N	H	AL	Moderate output. Alnico 8 magnet contributes crispy edge with bright high.
CAP-CCR2	CAP-CCR2	B	H	AL	Moderate output. Alnico 8 magnet contributes crispy edge with bright high.
CAP-PP1-N	CAP-PP1-N	N	H	AL	Tube construction of the pole-piece provides quick response, clarity and added harmonics.
CAP-PP1-B	CAP-PP1-B	B	H	C	Tube construction of the pole-piece provides quick response, clarity and added harmonics.
GB SPECIAL	GB SPECIAL	B	H	AL	Floating pickup co-designed by George Benson for hollow bodies or higher volumes. Warm, well rounded output with less feedback.
GB SPECIAL	GB SPECIAL	N	H	AL	Neck version of above.
HGD1	Hot Grinder 1	N	H	AL	Hot, but sharp enough to hear pick bites the strings.
HGD2	Hot Grinder 2	B	H	AL	Hot, but sharp enough to hear pick bites the strings.
INF1	INFINITY 1	N	H	C	Versatile and responsive with warm classic tone and added output.
INF2	INFINITY 2	B	H	AL	Enhanced midrange output. Alnico-5 magnet for individual string clarity. Excellent dynamics.
INF3	INFINITY 3	N	H	C	Provides the dynamic sound for chording and rhythm.
INF4	INFINITY 4	B	H	C	Brilliant lead pickup. Warm sounding with good harmonics.
INFS1	INFINITY SINGLE 1	M	S	AL	Warm single coil tone with added output.
INFS3	INFINITY SINGLE 3	M	S	C	Traditional sounding yet high output. Designed to work with humbuckers in the split position.
LZ1-N	LoZ-N	N	H	C	Traditional sounding yet high output. Designed to work with humbuckers in the split position.
LZ1-B	LoZ-B	B	H	C	High output yet low noise, active pickup operated by AA Batteries (3 volts)

LZ7-N	LoZ-N	N	H	C	Seven-string version of LZ3 pickup.
LZ7-B	LoZ-B	B	H	C	Seven-string version of LZ3 pickup.
LZ8-N	LoZ-N	N	H	C	Eight-string version of LZ3 pickup.
LZ8-B	LoZ-B	B	H	C	Eight-string version of LZ3 pickup.
PSNDS	PSNDS	M/N	S	AL	High output with complete clarity.
PSND1	PSND1	N	H	C	High output in the neck position with no "muddiness."
PSND2	PSND2	B	H	C	High output with enhanced harmonics.
S1	SINGLE 1	M/N	S	AL	Traditional sounding, but high output single coil with Alnico-5 polepieces for even string output. Designed to work with humbuckers in the split position.
S58	SUPER 58	all	H	AL	Classic, warm and versatile. Handles both jazz and rock without feedback.
S58C	SUPER 58 Custom	all	H	AL	Classic, warm and versatile.
SL58	SILENT 58	all	H	AL	Classic, warm and versatile. Handles both jazz and rock without feedback.
ST2	Short Tracer	M	S	AL	Alnico magnet provides full output in low profile setting.
STDH1	STANDARD 1	N	H	C	Clear sound with smooth midrange.
STDH2	STANDARD 2	B	H	C	Bridge version of STDH1.
TDB1	True-Duo Buckler	B/N	H	C/AL	Designed for switching between genuine double and single-coil sound in one pickup.
TDB2	True-Duo Blast 1	N	H	C/AL	Some True-Duo constructions as True-Duo Buckler, but the wiring enables True-Duo function as a pair, Bridge and Neck.
TDB3	True-Duo Blast 2	B	H	C/AL	Some True-Duo constructions as True-Duo Buckler, but the wiring enables True-Duo function as a pair, Bridge and Neck.
V7	V7	N	H	C	Tight, but bright. Very dynamic for chording and rhythm.
V7C	V7 Custom	N	H	AL	Smooth and dynamic tone with warm mid-range.
V8	V8	B	H	AL	Warm yet articulate lead pickup with enhanced overtones. Good harmonics without excessive brightness.
V8C	V8 Custom	B	H	C	Rich, harmonic tone with clarity in low-end.
V77	V77	N	H	C	Seven-string version of V7 pickup.
V77C	V77 Custom	N	H	C	Seven-string version of V7C.
V87	V87	B	H	C	Seven-string version of V8 pickup.
V87C	V87 Custom	B	H	C	Seven-string version of V8C.

IBANEZ BASS PICKUPS

ACHB-2	ACHB-2	B/N	H/P	C	High output humbucking pickup.
ADX5	ACTIVE DYNAMIX 5	B/N	H/A	C	Quiet, dynamic, punchy sound on all 5 strings. Two different sized bobbins provide even string output. Individually calibrated for neck and bridge positions.
CAP-DH	CAP Double Humbucker	B	H/P	C	3 varieties of different tones by combination of two humbuckers.
CAP-SA4	CAP Sonic Arch 4	B/N	H/P	C	Single-sized humbucker with blade polepiece. Well balanced traditional tone for any music and any style.
CAP-SA5	CAP Sonic Arch 5	B/N	H/P	C	Single-sized humbucker with blade polepiece for 5 strings. Well balanced traditional tone for any music and any style.
CAP-EXFN2	CAP EX FULL RANGE4 N2	B/N	H/P	C	Balanced tone and sound among each string.
DXH-4	DYNAMIX-4	B/N	H/P	C	Powerful with good midrange punch.
DXH-5	DYNAMIX-5	B/N	H/P	C	5-string version of DXH-4
DXH-6	DYNAMIX-6	B/N	H/P	C	6-string version of DXH-4
EXF-4	EX FULL RANGE 4	B/N	H/P	C	Balanced tone and sound among each string.
EXF-5	EX FULL RANGE 5	B/N	H/P	C	5-string version of EXF-4.
PFR-4	PASSIVE FULL RANGE	B/N	H/P	C	Powerful full range pickup with added low mids.
PFR-5	PASSIVE FULL RANGE	B/N	H/P	C	Powerful full range pickup with added low mids.
PFR-AL4	PASSIVE FULL RANGE	B/N	H/P	AL	Powerful Alnico magnet pickup with exceptional clarity and very even response.
PSJ	POWER SINGLE J	B/N	S/P	C	Powerful single sound with sharpness.
PPD4	POWERPOLE DUAL COIL	B/N	H/P	C	Passive bass sound with plenty of punch.
PSNDJ	PSNDJ	B/N	H/P	C	High output with added highs.
PSNDP	PSNDP	B/N	H/P	C	High output with plenty of punch.
SFR-GWB	SONIC FULL RANGE	B/N	H/P	C	Custom wound for GWB35. Quick attack, superior dynamics and added highs.
STD-P	STANDARD P	B/N	H/P	C	High output with plenty of punch.
STD-J	STANDARD J	B/N	S/P	C	High output with added highs.
STD-P2	STANDARD P2	B/N	H/P	C	Powerful sound with plenty of punch.
STD-J2	STANDARD J2	B/N	S/P	C	Powerful sound with added highs.
STD-M	STANDARD M	B	H/P	C	Powerful humbucker sound with dynamics.

BASS EQ DIAGRAM

PWC III 3-Band EQ (SR Prestige)
Volume, Bass Boost/Cut, Mid Boost/Cut, Mid Q, Treble Boost/Cut, EQ On/Off SW.

EQB-III 3-Band EQ (SR Premium)
Volume, Bass Boost/Cut, Mid Boost/Cut, Balancer, Treble Boost/Cut, EQ On/Off SW, Mid Frequency Select 250Hz / 600Hz.

Vari-Mid III 3-Band EQ (SRT, KS)
Volume, Top: Treble Boost/Cut, Bottom: Bass Boost/Cut, Balancer.

EQB-III 3-Band EQ (SR70x, SR60x, SR50x)
Volume, Bass Boost/Cut, Balancer, Mid Boost/Cut, Mid Frequency Select 250Hz/600Hz, Treble Boost/Cut.

EQB-IIID 3-Band EQ (SR40x)
Volume, Bass Boost/Cut, Balancer, Mid Boost/Cut, Treble Boost/Cut.

EQB-IIIB Style Sweeper 3-Band EQ (SR30x)
Volume, Style Sweeper Finger/Slap, Balancer, Top: Treble Boost/Cut, Bottom: Bass Boost/Cut.

Phat II EQ (GSR20x)
PHAT II EQ, Volume (Neck PU), Tone, Volume (Bridge PU).

EQB-IIDX 2-Band EQ (SRX)
Volume, Balancer, Bass Boost/Cut, Treble Boost/Cut.

EQB-IIIC 3-Band EQ (SRA)
Volume, Bass Boost/Cut, Balancer, Mid Boost/Cut, Treble Boost/Cut.

E4/E5 3-Band EQ (Grooveline)
Volume, EQ On/Off SW, Bass Boost/Cut, Mid Boost/Cut, Treble Boost/Cut.

Bartolini® MK2 3-Band EQ (BTB67x, BTB77)
Volume, Bass Boost/Cut, Balancer, Mid Boost/Cut, Treble Boost/Cut.

ATK N3 3-Band EQ (ATK1200)
Bass Boost/Cut, Volume, Mid Boost/Cut, Balancer, Treble Boost/Cut, PU Character Select SW.

ATK N2 3-Band EQ (ATK200)
Volume, Bass Boost/Cut, Mid Boost/Cut, Treble Boost/Cut, PU Coil Selector.

Aguilar® OBP-3 EQ (GVB1006)
Volume, Treble Boost/Cut, Balance, Mid Boost/Cut w/ Push-Pull Mid Frequency SW. (Push: 400Hz, Pull: 800Hz), Bass Boost/Cut.

Bartolini® NTBT 2-Band EQ (GWB1005)
Volume w/ EQ On/Off SW.. Pull: Bypass, Top: Treble Boost/Cut, Bottom: Bass Boost/Cut.

EQB-GWII 2-Band EQ (GWB35)
Volume, Top: Treble Boost/Cut, Bottom: Bass Boost/Cut.

1 Volume w/ PIB Active Circuit (PIB2)
Volume w/ PIB Active Circuit.

1 Volume w/ MDB Active Circuit (MDB2)
Volume w/ MDB Active Circuit.

SWITCHING SYSTEMS

H-S-H (5WAY) RG (HSH), JEM, UV, NDM, S (HSH), GRG (HSH)

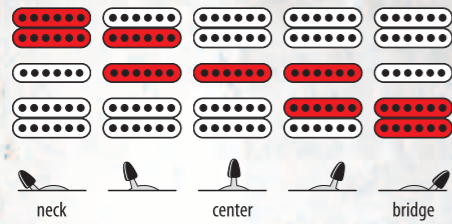

S-S-H (5WAY) GSA

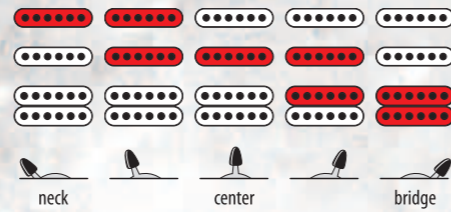

H-S-H (w/True-Duo Blast) SV

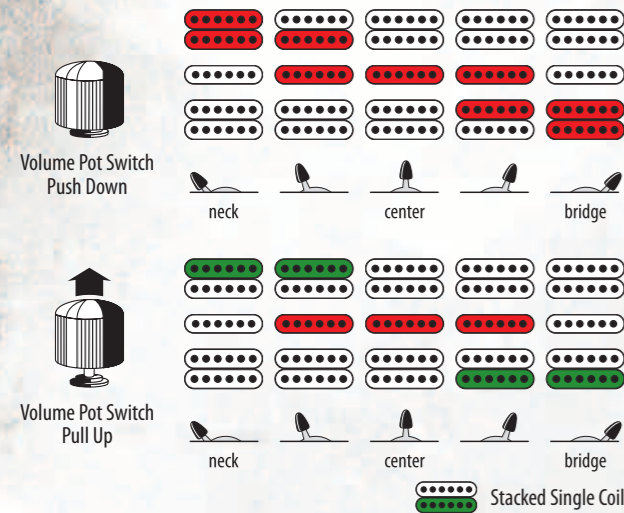

S-S-H (w/True-Duo Bucker) SA (SSH)

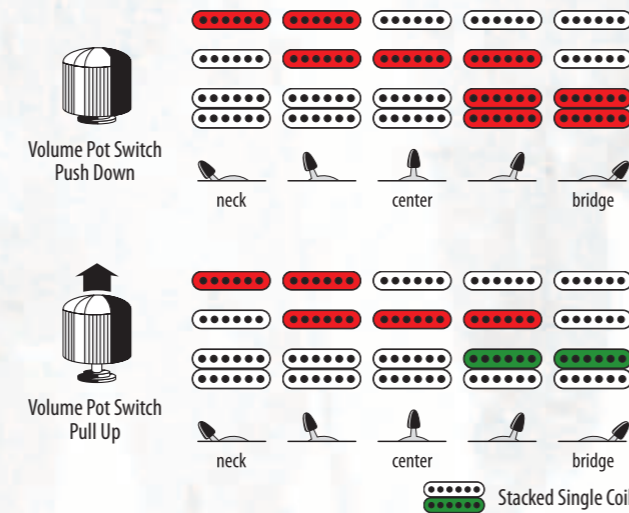

H-S-H (5WAY) EGEN18, EGEN8

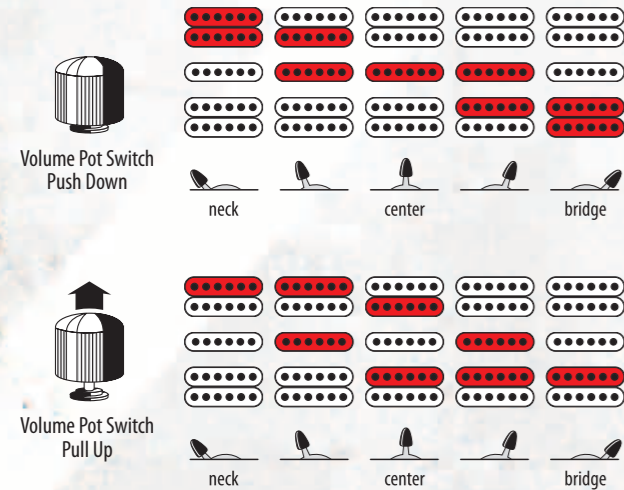

H-H (3WAY) JS2400

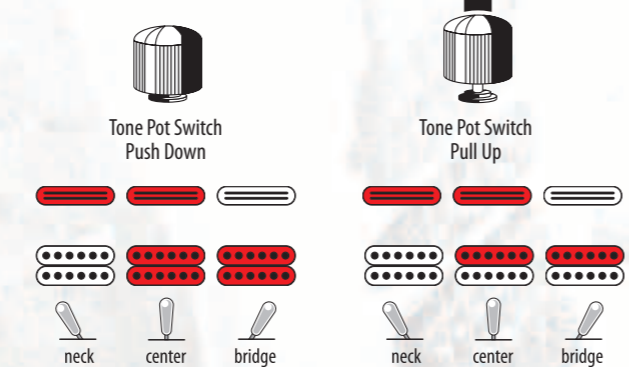

H-H (3WAY) DN, JS1200, JS1000, JS100

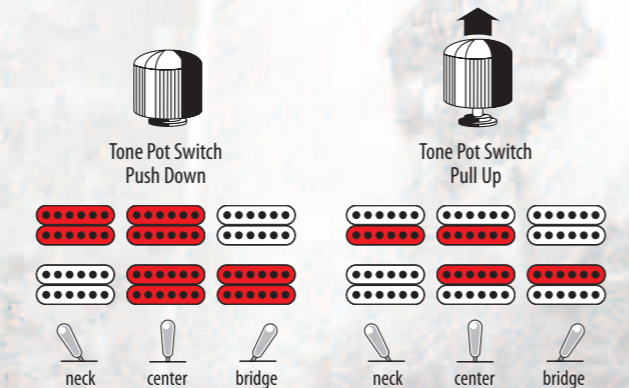

H-H-H (5WAY) AT100CL

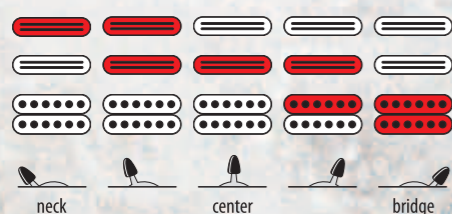

H-H (5WAY) RG (HH), S (HH), RGD Standard

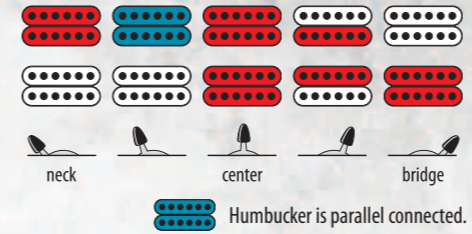

H-H (5WAY) FR

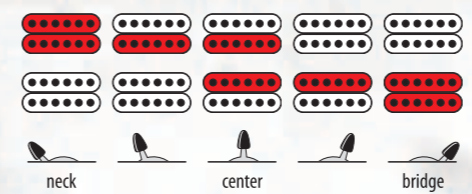

H-H (5WAY) PGM

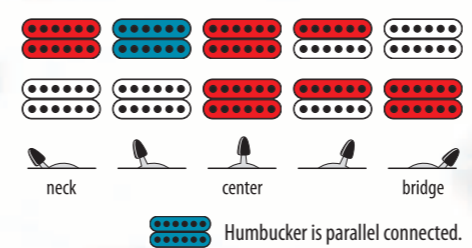

H-H (3WAY)

ART, ARTCORE, GRGA, DTT, APEX2, GB, GRGM, JSM, ARZ,
GART, MTM, PM, RGA, RGD Prestige, XPT (HH), ICT, STM,

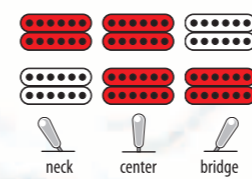

H-H (3WAY) XPT700XH

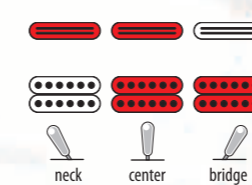

S-H (3WAY) APEX 100

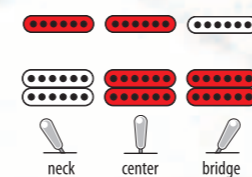

NECK MODEL	SCALE LENGTH	WIDTH AT NUT	WIDTH AT LAST FRET	THICKNESS AT 1ST FRET	THICKNESS AT 12TH FRET	RADIUS
GUITAR NECK DIMENSIONS						
APEX	648mm/25.5"	48mm	68mm	19mm	21mm	430mmR
APEX2	648mm/25.5"	48mm	68mm	19mm	21mm	305mmR
ARTCORE	628mm/24.75"	43mm	57mm	20mm	22mm (at 9F)	305mmR
ARX/ART	628mm/24.75"	43mm	57mm	20mm	22mm (at 9F)	305mmR
ARZ	635mm/25"	43mm	57mm	20mm	22mm	305mmR
ARZ7	635mm/25"	48mm	67mm	20mm	22mm	305mmR
AT	648mm/25.5"	40.5mm	57mm	21mm	23mm	305mmR
DN	628mm/24.75"	43mm	57mm	20mm	22mm (at 9F)	305mmR
EGEN	648mm/25.5"	43mm	58mm	18mm	20mm	430mmR
GART	628mm/24.75"	43mm	57mm	20mm	22mm	350mmR
GB	628mm/24.75"	43mm	57mm	20mm	23mm	305mmR
GRX	648mm/25.5"	42mm	56mm (at 21F)	20mm	22mm	350mmR
GRG1	648mm/25.5"	43mm	58mm	19.5mm	21.5mm	400mmR
GRGA	648mm/25.5"	42mm	56mm (at 21F)	20.5mm	23mm	400mmR
GRGM	560mm/22"	42mm	56mm	20.5mm	23mm	400mmR
GSA	648mm/25.5"	43mm	57mm	19.5mm	21.5mm	400mmR
JEM	648mm/25.5"	43mm	58mm	18mm	20mm	430mmR
JS	648mm/25.5"	42mm	58mm	20mm	22.3mm	250mmR
JS100	648mm/25.5"	42mm	57mm	20mm	22mm	250mmR
JSM	628mm/24.75"	43.5mm	57mm	20.2mm	23.3mm	COMPOUND
NDM	648mm/25.5"	42mm	57mm	20mm	22mm	240mmR
ORM	610mm/24.0"	43mm	57mm	20.5mm	23mm	320mmR
PGM	648mm/25.5"	43mm	58mm	18mm	20mm	430mmR
PM	628mm/24.75"	43mm	57mm	21mm	23mm	305mmR
PM35	628mm/24.75"	43mm	57mm	20mm	22mm (at 9F)	305mmR
SA	648mm/25.5"	43mm	56mm (at 21F)	20mm	23mm	400mmR
SUPER WIZARD HP	648mm/25.5"	43mm	58mm	17mm	19mm	430mmR
ULTRA-8	685.8mm/27"	54mm	80mm	20mm	21.5mm	430mmR
UV	648mm/25.5"	48mm	68mm	19mm	21mm	430mmR
WIZARD	648mm/25.5"	43mm	58mm	18mm	20mm	400mmR
WIZARD HP	648mm/25.5"	43mm	58mm	18mm	20mm	430mmR
WIZARD HP (RGD2120Z)	672mm/26.5"	43mm	58mm	18mm	20mm	430mmR
WIZARD II-7	648mm/25.5"	48mm	68mm	19mm	21mm	400mmR
WIZARD II-7 (RGD)	672mm/26.5"	48mm	68mm	19mm	21mm	400mmR
WIZARD II-8	685.8mm/27"	55mm	80mm	20mm	21.5mm	400mmR
WIZARD III	648mm/25.5"	43mm	58mm	19mm	21mm	400mmR
WIZARD III (DTI)	648mm/25.5"	43mm	57mm	19mm	21mm	400mmR
WIZARD III (RGD)	672mm/26.5"	43mm	58mm	19mm	21mm	400mmR
WIZARD-7	648mm/25.5"	48mm	68mm	19mm	21mm	430mmR
WIZARD-7 (RGD2127Z)	672mm/26.5"	48mm	68mm	19mm	21mm	400mmR
BASS NECK DIMENSIONS						
ARTCORE	770mm/30.3"	42mm	63mm	21.5mm	24.5mm	305mmR
ATK4	864mm/34"	42.5mm	63mm	21mm	24mm	305mmR
ATLAS-4	864mm/34"	38mm	62mm	19.5mm	21.5mm	305mmR
ATLAS-5	864mm/34"	45mm	67mm	19.5mm	21.5mm	305mmR
ATLAS-4 HP	864mm/34"	38mm	60mm	19.5mm	22.5mm	305mmR
ATLAS-5 HP	864mm/34"	45mm	67mm	19.5mm	23mm	305mmR
ATLAS-6 HP	864mm/34"	54mm	83mm	19.5mm	23mm	500mmR
BTB5	889mm/35"	47mm	76mm	20mm	22mm	400mmR
BTB6	889mm/35"	54mm	88mm	20mm	22mm	400mmR
Grooveline 4	864mm/34"	38mm	60mm	21mm	24mm	305mmR
Grooveline 5	864mm/34"	43mm	74mm	21mm	24mm	305mmR
GARTB	770mm/30.3"	41mm	60mm	20mm	21mm	305mmR
GATK	864mm/34"	42.5mm	63mm	21mm	24mm	305mmR
GSR4	864mm/34"	41mm	62mm	21mm	22mm	305mmR
GSR5	864mm/34"	45mm	67mm	21mm	22mm	305mmR
GSR6	864mm/34"	54mm	84mm	21mm	22mm	400mmR
GSRM	726.2mm/28.6"	38mm	58.5mm	21mm	22mm (at 12F)	305mmR
GVB	864mm/34"	53mm	72.3mm	19mm	19.5mm	305mmR
GWBI005	864mm/34"	45mm	67mm	19mm	21mm	305mmR
GWB35	864mm/34"	45mm	67mm	19mm	21mm	305mmR
K5	864mm/34"	45mm	67mm	19.5mm	21.5mm	305mmR
MDB4	864mm/34"	38mm	62mm	21mm	23mm	305mmR
PGBT4	864mm/34"	42.5mm	63mm	21mm	24mm	305mmR
SDB4	864mm/34"	43mm	60mm	22.5mm	22.5mm	305mmR
SR4	864mm/34"	38mm	62mm	19.5mm	21.5mm	305mmR
SR5	864mm/34"	45mm	67mm	19.5mm	21.5mm	305mmR
SR6	864mm/34"	54mm	83mm	19.5mm	21.5mm	400mmR
SRA4	864mm/34"	38mm	62mm	21mm	23mm	400mmR
SRA5	864mm/34"	45mm	67mm	21mm	23mm	400mmR
SRX4	864mm/34"	38mm	62mm	21mm	23mm	305mmR
SRX5	864mm/34"	45mm	73mm	21mm	23mm	400mmR