

OLYMPIC VILLAGE

Olympic Village Preparations

The purpose of the Olympic Villages Olympic Villages provide athletes and officials participating in the Olympic Games with facilities and services to enable them to lead an international and collective life before, during and after the Games. Article 46 of the Olympic Charter refers to this as follows:

"The Organizing Committee shall provide an Olympic Village for men and one for women so that competitors and team officials can be housed together and fed at a reasonable price".

In accordance with this provision, the operation of the Olympic Villages at the time of the Tokyo Games was aimed at providing as comfortable a living environment as possible, allowing both athletes and officials the opportunity for ample rest, physically and spiritually, to enable their participation in the Games under optimum conditions.

The Main Olympic Village at Yoyogi and the four Detached Olympic Villages Four Detached Olympic Villages were established in addition to the Main Olympic Village at Yoyogi. Viz.: the Hachioji Detached Village for cyclists; the Lake Sagami Detached Village for canoeing; the Oiso Detached Village for yachting participants; and the Karuizawa Detached Village for the three-day equestrian events. Article 46 of the Olympic Rules provides that: "The Villages shall be located as close as possible to the main facilities, practice fields and other facilities". Each of these Detached Villages was located as close as practicable not only to the site for the particular games for that Village but also to the training facilities. In addition, an equestrian park and billets were provided for grooms in charge of the horses which took part in the grand prix dressage and jumping events. These facilities were annexed to the Main Olympic Village at Yoyogi.

The sites of the Main and Detached Villages were selected with particular regard to their quiet natural environments, and this contributed materially to the physical and spiritual well-being of all athletes and officials.

Selection of the Main Olympic Village In the selection of the site for the Main Olympic Village for the Games of the 18th Olympiad in Tokyo, particular consideration was given to the following:—

(1) The number of participants in Olympic

Games had been steadily increasing. Adequate facilities therefore, including living quarters and dining halls, and an ample area of land on which to construct these facilities had to be found.

(2) Actual venues of the games and training facilities are of necessity scattered over a considerable area. The Main Olympic Village therefore, must be so placed that it is both close to these facilities and at the same time conveniently accessible by normal means of transportation.

(3) It must also be near the Tokyo International Airport, the arrival point of most Olympic teams.

(4) Environment at the site must be comfortable and sanitary so that athletes can relax from the stress and strain of their games, while keeping themselves physically fit in a refreshing atmosphere.

In previous Olympic Games, billets for military personnel, or schools have sometimes been used to accommodate Olympic athletes. In other cases, housing estates have been constructed in a manner to allow their later adaptation for public use.

With the decision that the Games of the 18th Olympiad would be held in Tokyo, the area known as Washington Heights in Yoyogi, Shibuya Ward, Tokyo was considered as the most likely site for the Olympic Village. Until the end of World War II this area had been a drilling ground for the now disbanded Japanese Imperial Army. This area was later converted to a dependent housing area for personnel of the US Army stationed in the Tokyo area. Washington Heights, unique in the centre of the capital, is surrounded by greenery and covers a wide expanse of land. It was thought that the large number of modern houses already built there would provide most suitable living accommodations for Olympic teams. This site was as well, within easy reach of most of the stadiums and sites of games, training fields and other facilities.

There seemed, however, to be but little prospect that Washington Heights would be released to the Japanese, and it was thought essential to acquire some other suitable site. The one chosen was the south zone of Camp Drake, a housing area of the US Army in Asaka, Saitama Prefecture, and it was suggested that the Japanese Government would negotiate with the US Army for its release so that the Olympic Organizing Committee could lease it from the Japanese Government to construct an Olympic Village. There was ample space at Camp Drake to build an Olympic Village, and the general environment was acceptable, though it was a dis-

tance of some twenty kilometres from Meiji Park where the main stadium was located. From the standpoint of transportation, therefore, Camp Drake was not regarded as an ideal site. However, by the planned construction of a highway network to be completed before the Games it was expected that this problem could be overcome in time for the Tokyo Games. It was initially decided then, that an Olympic Village would be built in Asaka and preparations were commenced to implement this plan.

In May of 1961, however, when the Japanese Government formally requested the return of Camp Drake, the US authorities replied that though they would permit a temporary use of this area during the Olympic Games they could not agree to its complete release. On the other hand, it was intimated by the US authorities that while it was impossible to release a part only of Washington Heights, they would be prepared to return the whole area to the Japanese Government if alternative suitable dependent housing was provided in another acceptable area.

The Organizing Committee not satisfied with that proposal, decided to negotiate once again for a release of the proposed site of an Olympic Village in Asaka, according to its initially approved plan. By this time, preparations for the Olympic Games, including the construction of roads had been started by both National and Local authorities, on the assumption that an Olympic Village would be built in Asaka, and it was thus considered that at this stage a change of site from Asaka to Washington Heights would present difficulties, even though there was no question that Washington Heights would be the more suitable site.

The Organizing Committee set up a special committee to deliberate on this problem, and the various difficulties were resolved by the National and local Government authorities concerned. Finally in October of 1961, a decision was reached that Washington Heights would be used, after all, as the site of the Main Olympic Village, and this was thereafter referred to as the Yoyogi Olympic Village. It was at the same time decided that a part of Washington Heights would be used for the construction of a National Gymnasium.

Later, in the beginning of 1962, there arose the question of making available a part of the Washington Heights area to NHK (Japan Broadcasting Corporation) for construction of its telecasting facilities. NHK proposed to build such a television broadcasting centre at Washington Heights, because the other site which it had selected earlier for this purpose had proved to be inadequate. This transfer of a part of Washington Heights to NHK had an important bearing on the scale of the Yoyogi

Olympic Village, for the area NHK sought to use was occupied by buildings that could have been utilized as billets for Olympic athletes and officials. As compared with Asaka which had ample space for training grounds as well as for buildings, Yoyogi Olympic Village was not on a scale large enough to provide adequate space for practice fields. Fear was expressed therefore, that the construction of an NHK TV station at Washington Heights would limit the space of practice grounds still further. In view, however, of the importance of televising the Olympic Games in Tokyo, it was agreed in March of 1963 that this part of Washington Heights would in fact be made available to NHK. Among the reasons advanced for this decision were that Washington Heights was an ideal site of a TV station; construction of such a TV station would not seriously interfere with the actual operation of Yoyogi Olympic Village; and NHK would provide new facilities in substitution for the buildings then existing at the site of the proposed TV station. The space of land to be made available to the NHK was to be 8.25 hectares before the Olympic Games and an additional 2.31 hectares after the Games. This reduced the actual total area of Yoyogi Olympic Village to approximately 66 hectares.

Selection of Detached Olympic Villages Oiso Detached Olympic Village and the three other Detached Olympic Villages were selected in the following manner:—

It was decided in August of 1962 that Hotel Oiso would be expanded in cooperation with Kanagawa Prefecture to provide living accommodations for participants in the Olympic yachting events. For the Karuizawa Detached Olympic Village, Hotel Seizan was selected in December of 1962. The sites of these Detached Villages were chosen after due deliberation of all factors concerning the available facilities near the sites of the Games.

It was recognized that it was not desirable to have the Olympic Villages widely separated, and accordingly it was planned initially that only two Detached Villages would be set up, one in Oiso and the other in Karuizawa. The site of the canoeing events to be held on the Lake Sagami, Kanagawa Prefecture, and the site of the cycling races to be held in Hachioji, Tokyo being located at a considerable distance from the Main Olympic Village at Yoyogi, raised some apprehension that transportation of athletes from the Main Village to these sites would involve a considerable time, but it was believed that the actual time required for transportation could be shortened during the Olympic Games by improvements to the roads and traffic facilities available.

When, in 1963, the International Sports Week

was held in Tokyo to stage a rehearsal of the Tokyo Olympic Games, it was found that transportation of competitors in these two events in fact, took a very long time. This raised the question of setting up additional Villages, and requests from the respective International Federations for Detached Villages to be provided close to the respective sites of these events were received. Because of the limited time left to furnish such additional Villages and the lack of adequate sites in the vicinity of the areas where these games were to be held, the task of establishing additional Villages in Kanagawa and Hachioji was one of considerable magnitude. In April of 1964, an official decision was reached to open two additional Detached Villages, inasmuch as no adequate means had been found to sufficiently alleviate the problem of transportation.

Operation policy and organization Establishment of operation policy:

In order to effectively operate the organization responsible for the administration of the Olympic Villages, the following preparations were deemed necessary.

- The determination of basic conditions necessary to the operation of the Olympic Villages, such as locations of Village facilities, the specific time during which the Villages would be open, the numbers of personnel to be accommodated.
- The setting up of an organization which would be responsible for making preparations in accordance with the conditions as determined above, this later to be developed into a nucleus of operating organizations in charge of the Olympic Villages.
- The study of various problems which would or might be encountered in the operation of the Olympic Villages, the formulation of concrete operating policies based on the results of this study, and finally to translate such policies into general rules and regulations.
- The hiring of personnel required for the effective running of these operating organizations.
- The provision of facilities necessary for the operation of the Olympic Villages; and the procurement and furnishing of necessary equipment and supplies as required.

Basic assumptions on which preparations were made: Preparations for the Olympic Villages at the Tokyo Olympics were to be made on the following assumptions:—

- Washington Heights in Shibuya, Tokyo would be the site of the Main Olympic Village. Maximum use would be made of all existing buildings and other structures.
- The period of operation of the Main Olympic Village would be from 15th September 1964 to 5th

November 1964 (52 days). This duration was determined with reference to the Olympics in Rome, on one hand, and after consideration of the actual period of the Tokyo Games. Allowances were made for the distances between the participating countries and Japan, arrival and departure schedules of chartered airplanes arriving at Tokyo International Airport, and other relevant factors. Accordingly, the Main Olympic Village at Yoyogi was required to be in a state of complete readiness on 15th September. Hachioji Detached Village and the Lake Sagami Detached Village were open for 52 days, from 15th September to 5th November. Oiso Detached Village was operated for 43 days, from 15th September to 27th October and Karuizawa Detached Village for 37 days, from 15th September to 21st October.

- The number of personnel to be housed at the Olympic Villages was estimated at 7,500. The actual calculation of this figure can be found in later paragraphs under the heading: "Facilities and billet assignment."

Organization responsible for making preparations

At the outset of the Organizing Committee, The Administration Division of the Organizing Committee was responsible for initial preparations for the Olympic Villages. Later, in April of 1962, an Olympic Village Division was created and this was later to take full charge of the operation of the Olympic Villages. The Olympic Village Division was initially composed of two sections: General Affairs and Facilities.

In April of 1964, however, the Olympic Village Division was reorganized by an expansion that brought a total of four branches under its control: Supply Section, Operation Section, Village Administration Section and Detached Village Section.

The Olympic Village Division moved its offices to the Main Yoyogi Village in August of 1964, but it was not until the early part of September that all the necessary personnel were given their respective assignments at the Olympic Villages.

Operation policy The operation policy for the Olympic Villages was formed through the following stages:—

- a. The stage where various problem areas were studied to clarify how the Villages should be operated:

The experiences in the operation of the Olympic Villages at the past Olympic Games and of the similar facilities at the Asian Sports Meets proved invaluable material in this connection. Specifically, the 3rd Asian Games held in 1958 in Tokyo, the 1960 Olympic Games in Rome, the 4th Asian Games held in 1962 in Djakarta (Indonesia) and the 1964

Winter Olympic Games in Innsbruck (Austria) were studied in detail with respect to village operation.

At the International Sports Week held in 1963 in Tokyo by way of rehearsal for the Tokyo Olympics, the Olympic Village Division participated directly in the various activities and studied in detail any problems that occurred at that time. These studies provided valuable guidelines for the specific establishment of our operation policy.

b. The stage where an operation policy was outlined with respect to each area of activity and a budget was made of necessary expenses:

The compilation of a budget was an important task at this stage. In 1962, budgets for all the years involved, including the year of the Olympics, and in 1963, a budget for the Olympics of the following year, were studied respectively. In December of 1963, a budget for the Olympic Games was officially fixed. This budget was supplemented when in April of 1964 the opening of two additional Olympic Villages, the Lake Sagami Village and Hachioji Village, was approved. To effectively study these draft budgets it was necessary to formulate general operation policy and ascertain the personnel and equipment required. Construction of facilities required for the operation of the Olympic Villages was entrusted to the Facilities Division which was responsible for all major construction.

c. The stage where certain outside organizations were delegated to handle specific services at the Olympic Villages:

In view of the fact that some of the services to be performed at the Olympic Villages were of a special character, opinions were expressed as to the advisability of entrusting such services to well-experienced and more qualified organizations. It was agreed that certain special services could be more efficiently performed by such organizations and that therefore these should be so delegated as soon as possible. In April of 1963, the Japan Hotel Association was entrusted with the catering service. Arrangements were also made with the Self-Defense Force for the supply of security guards to be stationed at the Olympic Villages. A number of other incidental services were sub-contracted through agreements between the Organizing Committee and the individual organizations concerned.

d. The stage where operation procedures were standardized with respect to each area of activity:

Detailed courses of action required for the implementation of the operation policy were laid down with respect to the construction of facilities, the procurement of equipment and supplies, etc. At the same time, operating procedures for general work were also defined and standardized in the form of simple rules or regulations.

The Main Olympic Village at Yoyogi, seen from the air



Systematic Chart of Village Operation

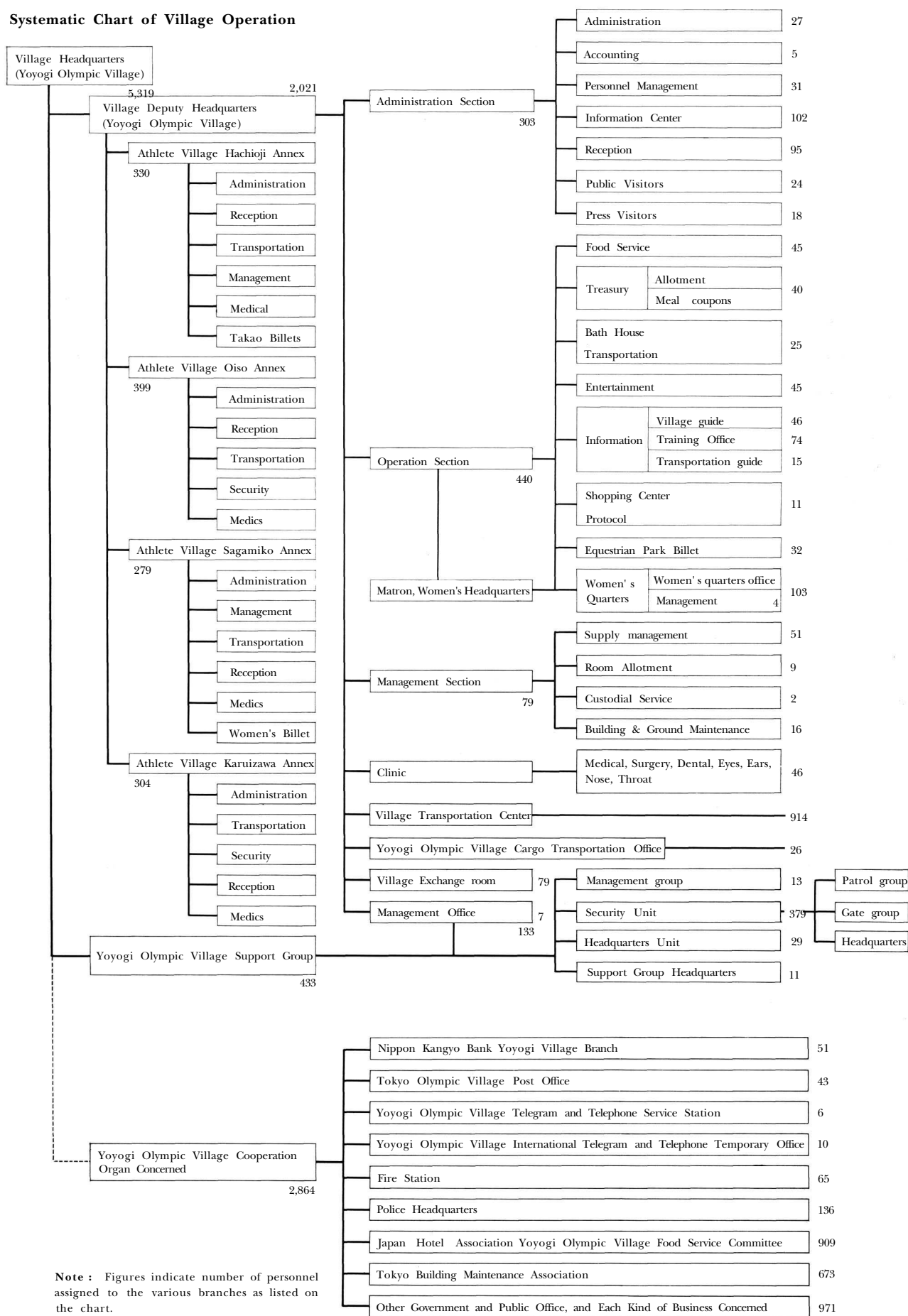

Facilities and billet assignment :

Preparation of facilities It was the responsibility of the Olympic Village Division to determine the requirements of each individual facility in accordance with the general operation policy, but it was the Facilities Division that actually prepared the plans for and constructed these facilities on the basis of such requirements. Facilities were to be prepared in conformity to the policy that the optimum use should be made of the existing facilities. Actual preparations were made in the following stages:—

a. Surveys were made of the existing facilities, and plans were made for their utilization, involving any changes or modifications required, and construction of new facilities (period up till March of 1964).

b. The existing facilities were altered or modified and new facilities were constructed (from April to August of 1964).

c. Any necessary modifications to the work done in the preceding stage were effected (from 1st September to 14th).

The above-mentioned stages was completed within the short period of time from 10th December 1963 when the area known as Washington Heights was returned to the Japanese Government.

Preparations for billet assignment One of the most important problems in the utilization of facilities was that of billet assignment.

This assignment of billets involved the question of how to best allocate living quarters for qualified athletes and officials. Assignments were made on the following premises:—

a. That Olympic teams would be assigned each a certain number of housing units where the existing wooden houses were utilized, and that athletes and officials of different nationalities would not be required to live in the same billet.

b. That billets for men would be assigned in one area and those for women would be provided in another area.

It therefore became imperative to have some indication of the total number of athletes and officials to be housed at the Olympic Villages, and as well an estimation of the actual composition of each nation's delegation. It was not possible to early obtain accurate statements of these participants as classified by nationality, sex and Village. Under these circumstances, billets were made available on the assumption that a total of 7,500 athletes and officials would be housed at the Olympic Villages. In the actual assignment of billets, every possible effort was made to obtain as reliable figures as possible, and to this end a number of sources of information were made use of, in particular, the answers to the

first and second preliminary questionnaires sent to all National Olympic Committees, and the answers to the final enquiries (National Entries).

The original estimate of 7,500 was in this way revised finally to 8,200, and billet assignments were made on this basis. Records of the method of billet assignments at past Olympics and expressed desires of the participating countries were also taken into account.

House grouping system The Main Olympic Village at Yoyogi was divided into seven blocks and a Service Office was set up in each of the blocks. It was thought that the optimum size of one block in terms of numbers of athletes and officials would be about 1,000. In fact, however, the Village consisted of different sized blocks, in that teams speaking the same language or belonging to the same area were housed in the same block, and because most of the blocks had certain physical limitations. Blocks were defined by roads as far as possible, but where this was not possible by nature of the lay-out, some of the blocks had to be defined by artificial boundaries.

The billets in each of the blocks were distinguished by different coloured paint, though in practice it was found that the paints used were not conspicuous enough to give the desired effect.

Calculation of numbers of persons or billeting capacities At the Main Olympic Village at Yoyogi there were both cottage type wooden houses and reinforced-concrete buildings, and these facilities were designated as billets for athletes and officials. The reinforced-concrete buildings consisted of both large and small rooms, while the wooden houses were variations of twelve different sizes of room. Capacity per housing unit was of necessity increased beyond the original estimates of 7,500 persons, and as a result it would not have been practical to accommodate any significant number of additional personnel.

The breakdown of billeting capacity was 5,920 persons for the wooden houses, 1,940 men for some of the ferro-concrete buildings and 1,008 women for the other reinforced-concrete buildings, in all a total of 8,868.

In order to calculate a net total capacity, however, certain space losses resulting from special billet assignments had to be deducted from the above-mentioned capacities. Specifically, allowances had to be made for the following losses:—

a. Some of the billets had to be left short of capacity because athletes of different nationalities were not housed in the same billet.

b. Private rooms, each having a capacity for more than two persons, were assigned to chiefs of

mission.

c. Additional space had to be provided for office use for each team.

d. Medical rooms had to be provided where teams brought their own doctors.

e. Space had to be made available for service offices.

These requirements were estimated to have taken space equivalent to the housing facilities for 1,100 persons (men only). This brought the net capacity down to 6,760 men, and final billet assignments were made on the basis of this net capacity.

Changes in estimated total number of Olympic participants The estimated total number of athletes and officials to participate in the Tokyo Olympics was an important figure. It affected the assignment of billets, the preparation of transportation facilities, the arrangement of the actual games and many other considerations. In February of 1964, the Organizing Committee requested each National Olympic Committee to submit preliminary statements of the likely number of their entries, and again, in June of the same year, they were requested to submit a second preliminary statement. However, only some 60% of the first questionnaires had been answered by May of 1964. These, plus the answers made to the second questionnaire, accounted for about 80% of the total replies. It was therefore, most difficult to make reliable calculations of expected numbers of competitors and numbers of officials of each team, for those countries who did not cooperate in these enquiries. Numbers of team officials were, however, calculated from general estimates of competitors. Special officials, such as doctors and nurses, were also included among these team officials.

Many of the answers to these questionnaires included only the allowable number of officials for the participants involved, while others appeared to be overstated, or included more than the permissible number of officials. Some answers thus showed such differences that they had to be modified to within reasonable limits before being incorporated in general estimates for preparation purposes. In the early

part of August of 1964, however, more reliable information was furnished by major participating countries, and it became necessary to make additional adjustments. It was not until the latter part of August of 1964 that the total number of Olympic participants was estimated finally at 8,138.

Procurement of equipment and supplies :

Basic policy of procurement The total value of equipment and supplies made available for use in the billets for athletes and officials, in the various related facilities and also in the administrative departments of the Olympic Villages amounted to about 350 million yen (US\$972,222) and comprised some 240 different items. Major items, as shown on Page 288, covered a wide range—from bedding and furniture to office supplies and daily necessities. Several of these items were required in such large numbers that considerable time was necessary to have them manufactured and delivered.

The basic policy of procurement and the progress of procurement activities were as follows:—

a. Equipment to be used in the billets was selected with particular regard to durability, simplicity and functional ability so that athletes could rest under the most comfortable of conditions.

Specifications of this equipment were prepared with due consideration of its serviceability at the Olympic Villages. In all cases, including that equipment which was leased, only entirely new equipment was procured.

b. The fiscal year of the Organizing Committee was from April to March of the following year, but some of the equipment requiring longer periods of manufacture had to be ordered prior to April of 1964. It was feared that if orders for such equipment were placed after April, it might not in fact be available in time for the opening of the Olympic Villages. Accordingly, an expenditure amounting to a maximum of 150 million yen (US\$416,667) was incorporated in the 1963 budget, and procurement orders for this portion were placed in the latter half of 1963.

Commodities placed in each Room

Item	Distributing standard	Item	Distributing standard	Item	Distributing standard
Writing desk	1/room	Cup	1/person	Clothesline	1/room
Bed	1/person	Tea set	1/person	Ashtray	1/room
Mattress	1/person	(saucer, spoon)		Kettle (coffee pot)	1/door
Filing cabinet	1/person	Washing pin	5/person	Kettle (Yakan)	1/door
Folding chair	1/person	Washing line	1/3—4 persons	Washing tub	1/door
Blanket	3/person	Foliage plant	1/room	Tray	1/door
Sheet	3/person	Waste basket	1/room	Door mat	1/door
Pillow	1/person	Locker	for room	Electric stove	As requested by those assigned to
Stand light	1/person		without drawer		Wooden-house
Bed-side rung	1/person	Japanese umbrella	1/3 persons		Billets
Hanger	3/person	umbrella stand	1/door		

List of Main Supplies (supplied with compensation)

Item	Quantity	Item	Quantity	Item	Quantity
Beds	7,909	Sofas	rooms 40	Gas stands	619
Bunk-beds	96	Benches	294	Projectors	1
Spare beds	1,000	Stand lights for typewriters	9	Vacuum bottles	3,236
Blankets	34,114	Stand lights	7,723	National flag filing boxes	22
Pillows	8,995	Loudspeaker apparatus	4	Cups	8,377
Night tables	7,943	Electric stoves	1,086	Tea sets	8,028
Steel lockers	1,380	Electric heaters	140	Coffee pots	960
Knee-hole desks	6	Screens	117	Kettles	940
One-side desks	564	Bulletin boards	44	Toilet rolls	21,800
Side desks	100	Black boards	47	Flowerpots	3,636
Writing desks	3,686	Medicine closets	77	Sponges	718
Long desks	241	Tea boards	13	Washing lines	2,660
Tables for Conference	96	Counter boards	3	Washing pins	44,200
Table for reception rooms	118	Liaison filing cabinets	12	Door mats	711
Side-tables	48	Key boxes	32	Bath mats	1,000
Athletes' cafeteria tables	425	Steel stack rooms	20	Bed side rugs	8,027
Employees' cafeteria tables	102	Portable safes	7	Curtains	34,600 m ²
Sitting tables	12	Filing cabinets	45	Vinyl curtains	4,000 m ²
Massage stands	220	Steel trays	73	Hangers	26,500
Ping-pong tables	2	Wagons	85	Carpets	3,940 m ²
Type stands	16	Bookshelves	9	Meal coupon holders	8,500
Flower stands	46	Clotheslines	3,306	Pails	100
Easy chairs	110	Movable drying stands	80	Waste baskets	4,733
Pivot chairs	466	Weighing-machines	2	Fire extinguishers	1,300
Folding chairs	11,224	Balances for linen storage	7	Heavy oil for fuel	200,000 gallon
Athletes' cafeteria chairs	2,550	Arm chairs	124	Sheets	about 172,000 in total
Employees' cafeteria chairs	408	Umbrellas	3,700	Pillow cases	about 60,000 in total
Table 6 set for reception rooms	12	Umbrella stands	1,050		
Table 3-set for reception	227	Mirrors	860		

c. Although considerable difficulty was experienced in obtaining reliable estimates of participants twelve to eight months before the actual Games, orders had in fact to be placed for those goods, such as beds and blankets, which would take a long time to manufacture. Thus, initial orders were for sufficient items for 5,500 persons. Additional orders were placed as later needs became apparent.

d. Inasmuch as all of the equipment procured was to be disposed of after the Olympic Games were over, a study was made of the feasibility of making prior arrangements for such disposition. Each item to be procured was examined as to the method by which it would be best disposed of. Some items were to be leased; some items were to be purchased on condition that they would be repurchased by the seller. Beds, blankets, pillows, linen (sheets and pillow covers), dining tables, theatre curtains, bed-side rugs, lockers, etc. were procured on a lease basis.

e. Preparations after national entries were submitted.

After the national entries had been received by the Organizing Committee, the initially estimated

number of Olympic participants was increased from the 7,500 to 8,138, and accordingly additional equipment and supplies were ordered on 29th August 1964. Orders for such additional equipment and supplies covered thirteen items, totalling about 59,-600 articles which cost about 24.7 million yen (US \$68,611). Delivery of these items of equipment and supplies had been completed before the opening of the Games.

Delivery of equipment All equipment was delivered during the 26 day period from 16th August 1964 in order that it would not interfere with the construction work at the Olympic Villages. Beds and lockers were delivered directly into the bed rooms. Other items of equipment and supplies were delivered by contractors to the collecting points which were set up temporarily at thirty locations throughout the Main Olympic Village. Goods were then carried from these collecting points to individual rooms by the billet maintenance personnel who were responsible for the cleaning operation. A total of 1,000 men, and 120 6-ton trucks were employed in the delivery of these goods.

List of commodities & Services received Gratis in Olympic Village

Item	Quantity	Place to be used	Remarks
Coca cola	450,428	Village cafeteria	contribution
Ovaltine	as required	Village club, each village annex	"
Shoyu, sauce	156 l./58 boxes table size 374 boxes	cafeteria	"
Matches	50,000 boxes	all villages	"
Indian tea	0.8 t.	cafeteria, athletes and officials	"
Ceylon tea	1.2 t.	cafeteria (including village annex)	"
Vinegar	215 boxes	"	"
Cosmetics	8,500 sets	Athletes and officials	"
Cleaner	8,000 "	cafeteria and others	"
Cleanser	8,000 "	"	"
Super Teepol	50 cans (18 l.)	cafeteria (including village annex)	"
Colour slides	9,000 sets	athletes and officials	"
Calendars	4,000 sheets	quarters and facilities	"
Milk, ice cream	as required	club	"
Table ashtray	6,300 pcs.	quarters and others	"
Kagome Tomato Juice	232 boxes (1,400 g./1 doz.)	cafeteria	"
Pokka Lemon	1,160 bottles (7,200 cc.)	"	"
Rice crackers	750 kg.	All villages	"
Aji-no-moto	Table size 11,840 pcs.	cafeteria	"
Razors	8,000 pcs.	Athletes and officials	"
V colour tape	5 colours 10 rolls each	Office	"
Tapestry	8,000 pcs.	quarters	"
Eggs	50,000 pcs.	cafeteria	"
Washing machines	19 sets	Women's Quarter and each Annex	"
Flashlights	24 pcs.	for guard	"
Shoyu sauce	2 l./37 boxes table size/115 boxes	Employees' cafeteria	"
Calpis drink	as required	Club and others	"
Corrugated cardboard	1,500 boxes	for packing	"
Drop curtain	1 set	for theatre	"
Photographs of Opening Ceremony			"
Photograph Album	8,500 sets	athletes and officials	"
Flower arrangement		common facilities	"
Coffee	4,200 kg.	Athletes' cafeteria	"
Album	8,000 copies	Athletes and officials	"
Towel	8,000 pcs.	"	"
Hand towel	2,000 pcs.	necessary places	"
Frame for photograph	small size about 3,800 large size about 200	quarters and common facilities	lent without compensation
Gestetner Printer	Hand type 100 sets	Delegation office and others	"
Typewriter	Electric 10 sets Portable 150 sets Standard 19 sets	"	"
Clock	Time tower 13 sets Others 850 pcs.	"	"
Chair and bench	480	Common facilities	"
Sewing machine	21 sets	Management office	"
Music instruments such as piano	piano 3 sets others	Theatre, club and tec.	"
Colour Television	7 sets	Club, office	"
Television set	132 sets	Delegation office and others	"
Radio set	30 sets	Club, office	"
Water cooler	42 sets	Athletes' cafeteria	"
Washing machine	14 sets	Women management office	"
Iron	52 sets	Management office and others	"
Stove	244 sets	athletes' quarters	"
Refrigerator	100 sets	Delegation office	"
Electric stand lamp	2,790 sets	athletes' quarters	"
Stereo	2 sets	Club	"
Japanese typewriter	5 sets	office	"
Bicycle	760 sets	in village	lent without compensation
Projector	2 sets	Theatre	"
Waste basket	1,200 pcs.	quarters, each place at outside	"
Printer	1 set	Printing room	"
Juice	118,000 bottles	athletes' cafeteria and others	contribution
Mutton	2 t.	athletes' cafeteria	contribution from New Zealand delegation
Apples	16 kg/300 cases	athletes' cafeteria and others	contribution of Nagano and Aomori
Grapes	6 kg/400 cases	"	contribution of Yamanashi
Tangerines	20 kg/50 cases	"	contribution of Shizuoka
Lemon	40,000 pcs.	Athletes' cafeteria	contribution of Sunkist lemon

Donations in kind As the Games approached, various donations in kind were offered both at home and from abroad. The Organizing Committee decided to accept only those which were of immediate use, with the exception of souvenirs. The items already listed in the budget of the Organizing Committee took precedence over some of these donations, depending on their relative importance in the operation of the Olympic Villages. (See Page 299)

Assignment of personnel

a. Planning

The manning of the operating organizations was equally important to the operation of the Olympic Villages as was the preparation of facilities and procurement of goods. In order to have all the necessary personnel prepared and available at the time of the Games, special efforts were made to recruit, train and assign the personnel during the preparatory stages which preceded the opening of the Olympic Villages.

Personnel assigned to the Olympic Villages were divided into two groups: 1) those who came under the direct control of the Olympic Village administration and 2) those who were dispatched to the Olympic Village Administration from other Divisions of the Organizing Committee, Government agencies and private organizations. Accordingly, different plans were made for these two groups of personnel. In the case of the latter group, each of the Government agencies or private organizations concerned, selected Village personnel from among its own members and took charge of both the training and the management of these personnel. Some organizations hired additional personnel to supplement their own staff.

Personnel under the direct control of the Olympic Village Administration were recruited, trained and assigned by the Administration itself. To facilitate the personnel management of the Administration, a Labour Section was set up and was held responsible for all problems relating to these personnel and it acted as a central organ to control all personnel affairs involving these employees.

b. Recruiting of personnel

Olympic Village personnel were recruited in consideration of: 1) economising of personnel expenses, 2) special status of personnel, namely, their expressed desire to cooperate in this work (although work itself was on a temporary basis) and the technical ability required of certain types of work, and 3) the efficiency of the labour. A first requirement for Olympic Village personnel was that they be able to work for sixty consecutive days including the period of training. It was feared at first that difficulties would be encountered in recruiting the de-

sired number of qualified personnel because of the temporary nature of their work. As the nation, however, became more concerned with the Tokyo Games, a number of persons applied for work directly to the Labour Section. Applications for positions, however, were not processed through the Olympic Village Administration but were handled instead by the Public Employment Security Offices in the Metropolitan area. Applicants recommended by these Offices received a final screening by the Administration.

In order to ensure effective utilization of personnel in conformity with the cost-saving policy, Olympic Village personnel were recruited, not at one time, but as the work load in each area of activity increased.

c. Training of personnel

Practical training was given to the Village personnel so hired, to enable them to perform their respective jobs efficiently. Particular consideration was given to the subjects and methods of training to achieve maximum results within the shortest possible time.

Major subjects of training were 1) the duties of all Olympic Village personnel, 2) an outline of the Olympic Villages, and 3) specific job training.

Training methods were adopted to give effective training to the incoming personnel, viz.—emphasis was placed on the training of a small number of personnel in each type of job, it being found more effective to handle this way than to train a large number of personnel at one time; practical training, rather than lectures or oral orientations, was given by means of audio-visual aids. Orientation of the Olympic Villages and duties of Village personnel were explained through picture slides; training was given "on the job" to enable each person to be fully appraised of which would be required of him in the respective assignments. Simulated Olympic teams were organized to stage two actual rehearsals under the hypothetical conditions of the opening of the Olympic Village so that the Village personnel would recognize their specific roles in the overall organization.

The greatest effort was expended on the training of interpreters. Interpreters required by the Village were first trained by the Foreign Affairs Division of the Organizing Committee and later received further specific training at the Olympic Village Administration. The latter phase of training was arranged to meet specific requirements at the Olympic Villages. The training of interpreters thus required more time than for any of the other positions.

d. Assignment of personnel

Olympic Village personnel were assigned to their

respective positions, according to the requirements of the various branches. The number of interpreters proficient in languages other than English was less than required, and to cover this deficiency, an Interpreters' Centre was set up to provide a pool of

interpreters of five languages (English, French, German, Spanish and Russian). Special interpreters (foreign nationals speaking more than two languages) were assigned to the facilities most frequently used by athletes and officials, such as the

Description of Olympic Village Buildings

Wooden Structures

Spec. Type	Sq. Met.	No. of per- sons accom.	No. of rooms	Area of rooms	Area per person	Av. area each room	Win- dow space	Toilet faci- lities	Bath rooms	Total of such facilities							
										No.	Area	Persons accom.	Rooms	Total room area	Window space	Toilet faci- lities	Bath rooms
A1	90.55	8	4	56.15	7.02	15.90~12.27	16.20	1	1	15	135.82	120	60	842.25	243.00	14	15
A2	97.29	9	4	61.27	6.80	25.09~ 9.45	16.20	1	1	4	389.16	36	16	245.08	64.80	4	4
B1	111.85	11	3	68.09	6.19	38.30~11.65	16.20	2	1	79	8,836.15	869	237	5,379.11	1,279.80	158	79
B2	124.32	10	4	66.52	6.65	26.35~ 9.75	17.82	2	1	40	4,972.80	400	160	2,660.80	721.80	80	40
C1	142.29	10	5	83.38	8.34	34.37~10.27	19.44	2	1	3	426.87	30	15	250.14	58.30	6	6
C2a	147.79	8	5	80.78	10.09	33.21~ 8.22	17.82	3	2	1	147.79	8	5	80.78	17.82	3	2
C2b	159.27	11	5	99.54	9.51	40.89~ 9.14	22.68	3	3	3	477.81	33	15	298.62	68.00	9	9
C2c	157.74	10	5	91.21	9.12	30.33~ 9.79	22.68	3	2	4	630.96	40	20	364.84	90.07	12	8
A1a	83.52	7	3	48.99	7.00	21.55~ 8.73	13.77	1	1	91	7,600.32	637	273	4,458.09	1,253.10	91	91
A2a	110.36	8	4	60.57	7.57	21.20~ 8.61	19.44	2	1	6	662.16	48	24	363.42	116.60	12	6
B1a	127.44	12	4	67.92	5.66	25.57~10.55	22.68	2	1	162	20,645.28	1,944	648	11,003.04	3,674.16	324	164
B2a	155.64	13	5	85.44	6.57	26.13~11.38	24.30	2	1	135	21,011.14	1,755	575	11,534.40	3,280.50	270	135
Total										543	65,936.26	5,920	2,148	37,489.57	10,859.67	984	554

Ferro-Concrete Building

Men or Women	Spec. Floor	Sq. Met.	No. of persons accom.	No. of rooms	Area of rooms	No. of accom each room & area each	Win- dow space	Toilet faci- lities	Baths & showers	Total								
										No.	Area	Ac- com.	Rooms	Room area	Area each person	Win- dow space	Toilet faci- lities	Baths & showers
Men	1	749.48	44	16	401.30	3 14 9m ² 1 2 13m ²	83.6	12	4 3									
	2	743.08	50	18	454.86	3 16 9m ² 1 2 13m ²	85.8	10	4 5									
	3, 4	"	"	"	"	"	"	"	"									
	Total	2,978.72	194	70	1,765.88	3 62 1 8	341.0	42	16 18	10	29,787.20	1,940	700	17,658.80	3 620 1 80	3,410	420	160 180
Women	1	749.48	54	15	376.57	4 13 6.7m ² 1 2 13m ²	83.6	9	3 3									
	2	743.08	66	18	454.86	4 16 6.7m ² 1 2 13m ²	85.8	10	4 5									
	3, 4	"	"	"	"	"	"	"	"									
	Total	2,978.72	252	69	1,741.15	4 61 1 8	341	39	15 18	4	11,914.88	1,008	276	6,964.60	4 244 1 32	1,364	156	60 72

Registration Office, Visitors' Lounge, Village Information Office, Dining Halls, etc.

A total of 5,319 persons was assigned to the Olympic Village Administration. These personnel worked in two or three shifts, as the circumstances required.

General Condition and Operation of Yoyogi Olympic Village

Yoyogi Olympic Village: This Main Olympic Village at Yoyogi covered a total area of 66 hectares, and was situated in an area surrounded by many of the main stadia and Games sites. The Village was close to a station on the local electric railway loop line which runs through the centre of Tokyo, and also could be easily reached from one of the private railway lines. The main gate of the Village faced a Bypass Highway with access to the Tokyo International Airport via the Metropolitan Expressway. All the roads connecting the Village and the training field as well as the sites of the games are well paved and conveniently accessible by common means of transportation.

Billets and related facilities: The Main Olympic Village at Yoyogi was entirely enclosed and comprised modern two-storey wooden cottages and ferro-concrete buildings built on a wide expanse of green ground. These facilities had been constructed to accommodate US military dependent personnel. The geographical and other natural conditions of this Olympic Village were as follows:—

Area of land:	approximately 66 hectares
Distance from east to west:	approximately 800 metres
Distance from south to north:	approximately 1,400 metres
Circumference:	approximately 4,200 metres
Difference in elevation:	approximately 9 metres

The main avenues and streets at the Village were given the names of Athens, London, Helsinki, Melbourne, Rome and Mexico City, being the cities where the Olympics have been held since the end of World War II and the city which will host the next Olympic Games. The total length of the Olympic Village avenues and streets at Yoyogi was about 6,500 metres.

The billets, divided for men and for women, were surrounded by lawns and trees. The men's billets consisted of 249 wooden houses and 10 four-storey reinforced-concrete buildings, with a total of 2,848 rooms. These facilities had accommodation for about 5,900 men. The women's billets consisted of

4 four-storey reinforced-concrete buildings, with a total of 276 rooms, sufficient to accommodate 1,008 women. Most of these facilities were modified somewhat to meet the requirements of athletes and officials. Details of these billets and their related facilities are given below:

Billets

a. Reinforced-concrete buildings

There were 700 rooms in the 10 four-storey buildings for men and 276 rooms in the 4 four-storey buildings for women. Hot water was supplied centrally from a central boiler system, and a separate kitchen was provided on each storey.

b. Wooden houses (for men)

Under this heading were 249 units, consisting of 543 houses, either one or two stories. A convenient water heating apparatus (heated by gas) was installed in each house. Each house had also its own kitchen facilities.

Related facilities: Two gas supply systems of a total capacity of 4,600m³/H (max.) were provided. Two water supply systems, each having a capacity of 1,600 tons/day, were installed. 200 tons of water could be pumped up at a time from the underground reservoir to the supply tower. A single power supply system was provided, and consisted of four transformers, each having a capacity of 2,500 KWH. Two boiler systems were installed. One consisted of two boilers with an effective heating surface of 660m² each and one boiler with an effective heating surface of 220m², at pressure limit of 8kg/cm². The second system consisted of one boiler with 151.24m² and another boiler with 75.62m², at pressure limit of 4kg/cm².

The related facilities included the office of the Olympic Village Administration, Women's Quarters Centre, Service Office, Fire Station, Clinic, Theatre, Clubs and Shops. These facilities were provided by modifying some of the existing buildings. Facilities for the Service Centre, Dining Halls, Sauna, Baths and Training Ground were newly constructed. The Service Centre was housed in a two-storey building and on the ground floor of this Centre were the Registration Office and Visitors' Lounge. On the second floor were provided the Information Office, the Bank, the Post Office, the Telephone and Telegraph Office, the Cashier's Branch, etc. The main facilities at the Village can be summarized as follows:

Dining halls	3 (one of them was at the Women's Quarters Centre)
Service Centre	1 (Registration Office, Visitors' Lounge, Information Office, Bank, Post Office, Telephone & Telegraph)

	Office, etc.)
Telephone Exchange	1
Shopping Centre	1
Theatre	1
Clubs	2 (one at the Women's Quarters Centre)
Bath houses	4 (one of these was a Japanese-type bath house and was located at the Women's Quarters Centre.)
Steam baths	2 (one at the Women's Quarters Centre)
400-metre track	1
25-metre heated swimming pool	2
Weight-lifting training site	1
Fire Station	1
Medical Clinic	1
Women's Quarters Centre	1

Control of billets: The men's billets were scattered over such a wide area and were divided into seven sections, from Area A to Area G. A Service Office was set up in each area. The women's billets were separately fenced off to afford effective control. Each of the four buildings used as women's quarters was numerically designated, from 1 to 4, and a Service Room was provided in each building. These Service Offices and Rooms provided the following services:— 1) supply and control of goods, 2) maintenance complaints, 3) general information, 4) processing of requirements of resident athletes, 5) transmittal and delivery of documents and other materials, 6) sewing and ironing services, and 7) services required at the time of entry to and withdrawal from the Village.

The control of the billets and the furnishing of services to the Olympic teams by the Service Offices was accomplished very effectively for the large Main Olympic Village at Yoyogi.

Operating principles of organizations: The organizations responsible for the operation of the Olympic Villages were set up in due consideration of the requirements of Village residents, the number of residents, the operation period of the Villages, etc. Such operating organs were organized on the following principles.

Organization of the Olympic Village Division:

The Olympic Village Division was responsible for the operation of the Olympic Villages. The Division consisted of the Village Administration Section, the Operation Section, the Supply Section and the Detached Village Section, each Section having subsections under its direct control. The Equestrian Park Annex came under the control of the Opera-

tion Section and was treated as part of the Administration organization. All orders and other instructions concerning the Village operation were transmitted from the Director through the vice-director to various section heads to the foreman and to the employees.

At the Main Olympic Village at Yoyogi, the Ground Self Defense Force provided support for the operation of the Village, and the Commander of this support group assisted the Director.

Services performed by other Divisions of Secretariat of the Organizing Committee: Personnel were despatched from other Divisions of the Secretariat of the Organizing Committee, inasmuch as the operation of the Olympic Villages involved certain specialized fields of activity and because these Divisions had functions similar to some of those to be performed by the Division. The services performed by these Divisions were as follows:—

The Interview Room was operated by the Press and Public Information Division; the Transportation Centre and the Telephone Exchange by the Transportation and Communication Division; the Training Office and the Village Training Sites (training facilities for athletic sports, swimming and weight-lifting), by the Sports Technique Division; the Medical Clinic, by the Stadium and Ticket Division; and the Maintenance and Repair Service, by the Facilities Division.

Services entrusted to outside organization: Additional services, such as bank, postal, telephone and telegraph services; freight transportation; security guards; fire fighting service; catering; and cleaning operations, were entrusted either to government agencies or specialist private organizations.

A Detached Village Director was appointed for each of the four Detached Olympic Villages, and came under the control of the Director of the Olympic Village Division. The operating body at each Detached Village was organized correspondingly to the Main Olympic Village, except in the cases where special consideration was needed to meet specific particular requirements of the Detached Village.

Functions of the Olympic Village Administration: The Olympic Village Administration performed the following major functions during the operation of the Olympic Villages:

Performance of direct services for the operation of the Olympic Villages;

The Village Administration Section, the Operation Section and the Supply Section were responsible for the services of this group;

Control of indirect services for the Operation of the Olympic services;

Procurement of goods and services (Village Administration Section)

A unit was created and made a part of the Administration Section to perform overall administrative control and inter-division liaison in the Village Division. Specifically, the Village Administration Section performed the following duties: general services (Village Administration Officer), control and transmittal of information (Information Officer), personnel management (Labour Office) and control of financial matters (Finance Branch).

General coordination of services: The Village Administration Officer was responsible for general coordination of services, and at the same time for the performance of general services, and he was required to coordinate the diverse activities conducted throughout the Main Olympic Village. A number of other organizations took charge of some of the

Village operation activities. For example, the Shibuya Fire Station was responsible for fire fighting service, and security guards of the Metropolitan Police Department provided security service in the area around the Main Olympic Village. Other services, such as the Medical Clinic and Freight Handling Office, were performed by other Divisions of the Organizing Committee. It was therefore, a most important function of the Village Administration Officer to see that the activities of these outside organizations were well coordinated in the overall setup of Village operation.

Performance of general services: General services performed by the Village Administration Officer included control of office equipment and supplies, processing of visits to Village employees, maintenance of the division offices, information service at the division office and control of vehicles.

Control of information and public relations: An Information Centre was established for the purpose of centrally processing all information necessary for

Chart of Village Information Route

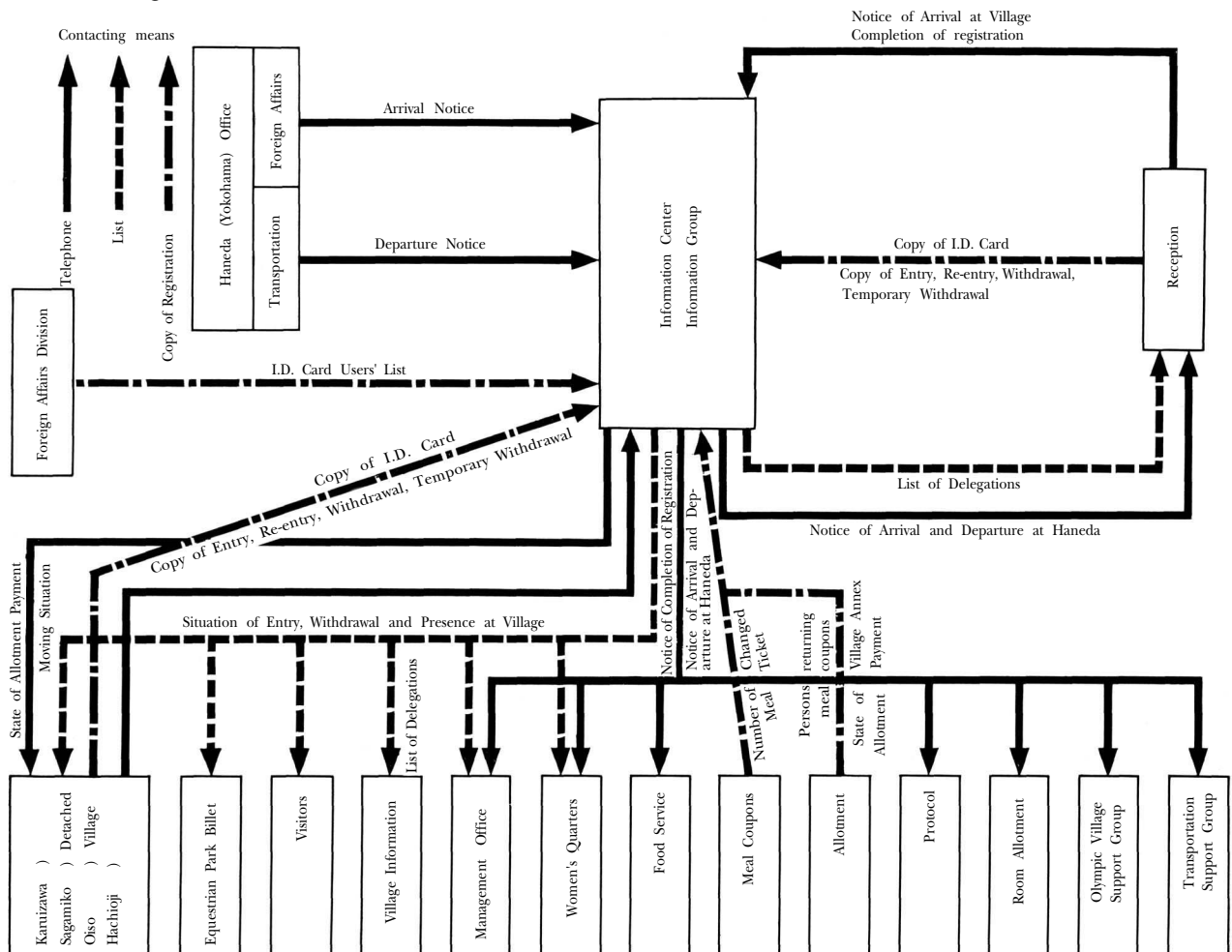
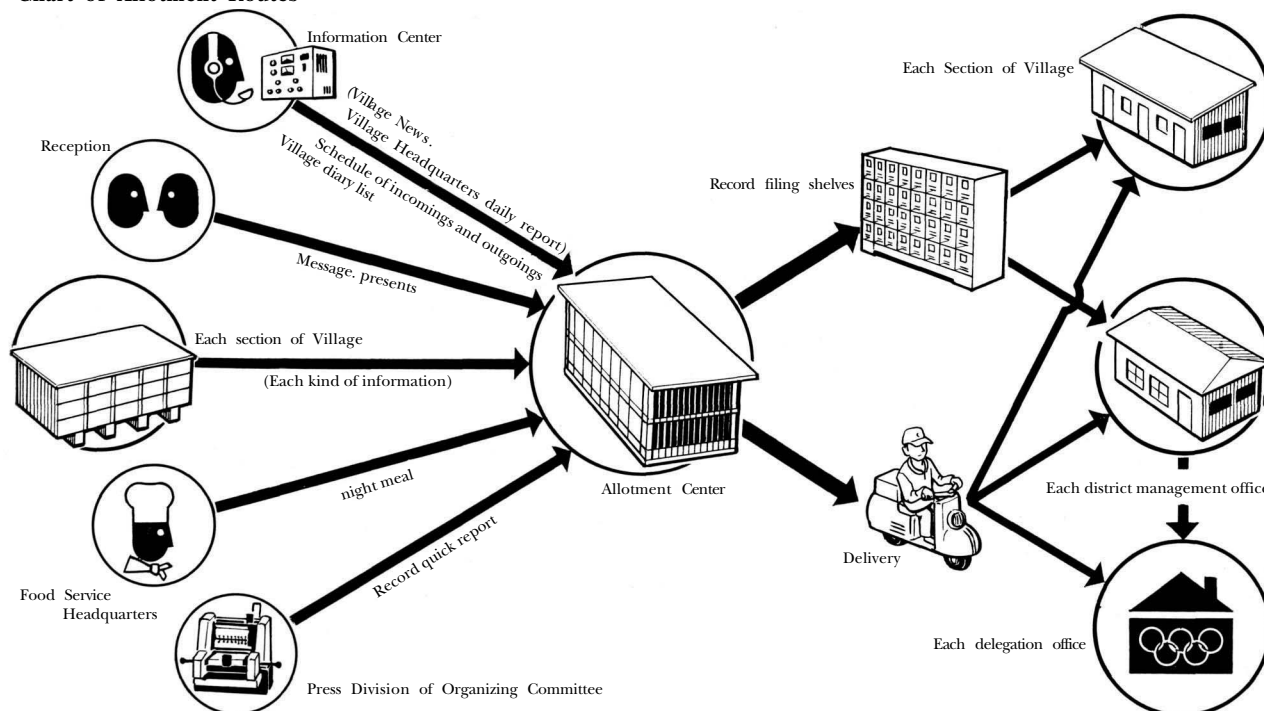

Chart of Allotment Routes



the smooth and effective operation of the Olympic Villages. For this purpose, close contact was maintained, not only with the Village Division and other Divisions of the Organizing Committee but also with the participating outside organizations. This was handled as follows:

a. Information Group

The primary duties of the Information Group were to obtain information pertaining to the expected date and time of registration and clearing of Olympic teams and their numbers at the earliest practicable time and transmit such information to the various Village operating organizations and to keep them informed on the accurate numbers of Village residents in all of the housing areas.

Types of information handled by the Information Group and the methods used for collecting the necessary information are indicated in the Table. Routes of collection and distribution of information centering around the Information Group are illustrated in this section.

Tables and rosters prepared by the Information Group on the basis of the information and data which it collected or received are shown in Table 16. These tables and rosters were classified by the Information Group according to their respective blocks, printed by the Documentation Group and distributed to all the departments concerned through the Distribution Group. The Information Group worked around the clock and played a very important role in the conduct of Village registering and clearing.

b. Distribution Group

It was the primary duty of the Distribution Group to deliver promptly the large volume of printed matter to all the offices of the Olympic teams as well as to the various departments of the Olympic Village Division. Types of printed matter handled by this Group and routes of daily distribution are shown in Figure 8. Letters and other papers as well as gifts to individual athletes and officials were all processed through this Group and distributed through the offices of the Olympic teams.

c. Documentation Group

The Documentation Group received and examined all documents of the Olympic Village Division in accordance with its standard procedures. Translators to English and French, and typists of Japanese, English and French were assigned to this Group. These translators translated circulars, bulletins and other written materials. A large volume of printed matter was produced daily by the offset printing machine.

d. Village Newspaper Group

The Press Group was responsible for publishing the Olympic Village Newspaper and the Olympic Village Division Bulletin.

The Olympic Village Newspaper was published with a view to providing items of interest to the Village residents. It was hoped that this publication would contribute towards the convenience and enjoyment of the Olympic Village and to afford closer relations among the participating athletes and officials. News and other articles carried in this publication covered a broad range of subjects, such as impressions of the Olympic Villages, items of

topical interest, history of the Villages, arrivals and departures of participants, guides to theatres and clubs, radio and TV programmes, lost and found articles, weather forecasts, stories of participating countries. The Olympic Village Newspaper was 17"X22" and consisted of four or five pages. The first of ten issues appeared on 15th September and the last number on 23rd October, being published every four days. The number of copies circulated per issue was 1,000 in Japanese, 3,000 in English and 1,000 in French. News coverage was limited within the compounds of the Olympic Villages.

The Olympic Village Division Bulletin was intended to provide information within the Division itself, covering items of communication, schedules of games and other events, etc. A total of sixty issues was made during the period from 2nd September to 4th November. The Bulletin played a significant role in maintaining close contact with and among the various departments of the Administration which were located in many different parts of the Olympic Village.

Personnel management: The Labour Office was responsible for the management of all personnel assigned to the Olympic Village Administration and performed such major functions as coordination of personnel assignments, payment of wages, and welfare service. Coordination of personnel assignments concerned primarily the work of increasing or decreasing the number of personnel or making reassignments of personnel according as work loads increased or decreased. This coordination was 24-hour work system, while other sections operated made through the chiefs of the respective offices. The working hours of some sections required a for 14 hours or less every day, and accordingly work schedules of personnel were arranged in shifts. In principle, each employee was required to work 8 hours a day, lest overwork should impair his health and result in poor work efficiency. A medical clinic,

billets, dining halls, recreation rooms, etc. were provided for the exclusive use of employees.

"The Village Plaza" was published to introduce the activities of the labour office and promote mutual understanding among the Village personnel.

Control of disbursements: The Finance Officer controlled all disbursements required for the operation of the Olympic Villages. It was responsible for estimations of expenditures, processing of disbursements and keeping within the approved budget.

The Olympic Village Division prepared the original budgets, which were then coordinated with the Budget Section of the Finance Division. Any budget involving contractual arrangements was referred further to the Contract Section. All payments were to be made through the Disbursement Division. During the operation of the Olympic Villages, the Finance Officer received advance funds for the Main Olympic Village and for each of the Detached Villages, and made direct payments.

Status of Village registering and clearing and Village residence of athletes: Registering of athletes at the Main Olympic Village reached a peak on and about 1st October 1964, as had been expected. Registerings increased somewhat around 20th October and 30th October. Registerings around 20th October were of the athletes which had left the Village for sightseeing tours of Nikko, Fuji, etc. and afterward returned to the Village. Registrations around 30th October were attributed to the teams which had likewise left the Village to attend local tournaments in volley-ball, athletic sports, etc.

Status of registrations as classified by time: Many of the early arrivals at the Village came late in the evening and these initial registrations necessitated the office working from 6 p.m. to 1 a.m. the following morning. The athletes of Germany and

Chart Showing times of arrival of Teams at Olympic Villages

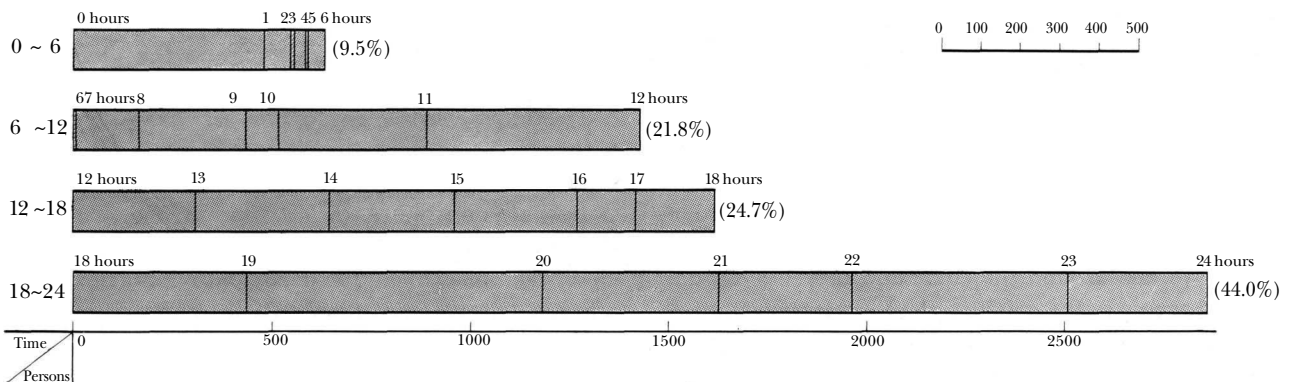

Order of Admission to Olympic Village of Teams

Date	Countries
26 Sept.	Australia, Congo, Korea, Rumania (4 countries)
30 "	Austria, Chad, Mongolia, New Zealand, Niger (5 countries)
1 Oct.	Bulgaria, Great Britain, Philippines, Yugoslavia (4 countries)
2 "	Finland, Germany, Italy, Japan, Monaco, Netherlands, Sweden, Tanganyika (8 countries)
3 "	U.S.S.R., Mali, Tunisia, India, Madagascar, Liberia (6 countries)
4 "	Brazil, Burma, Czechoslovakia, Ethiopia, France, Ivory Coast, Jamaica, Liechtenstein, U.A.R., Uganda (10 countries)
5 "	Afghanistan, Canada, Ghana, Hong Kong, Iran, Nigeria, Norway, Poland, Switzerland, Trinidad & Tobago, Turkey, U.S.A. (12 countries)
6 "	Belgium, Cambodia, Cuba, Denmark, Hungary, Kenya, Morocco, North Rhodesia, Pakistan, Rhodesia, Senegal, Spain (12 countries)
7 "	Argentine, Bahamas, Chile, Panama, Uruguay, Venezuela (6 countries)
9 "	1st time: Bolivia, Cameroons, Ceylon, Iceland, Ireland, Israel, Libya, Malaysia, Mexico, Nepal (10 countries)
"	2nd time: Algeria, British Guiana, Colombia, Costa Rica, Dominican Republic, Greece, Iraq, Lebanon, Luxemburg, Netherlands Antilles, Peru, Portugal, Puerto Rico, Taiwan, Thailand, Viet Nam (16 countries)

Note: 94 countries participated in the Games. Countries which participated in the Olympic Village Admission Ceremonies (including Libya which stayed outside Village) numbered 93.

U.S.S.R. (which came from their respective training camps) and the Japanese teams, were registered during the daytime. If the German and Russian teams had come directly to the Village from the Tokyo International Airport, the percentages of registrations at night would have been higher than indicated in this section.

Status of Village clearing: The peak in the number of athletes leaving the Village was reached on 25th October, the day following the Closing Ceremony. This peak showed a sharper curve than it did on the arrivals. A number of clearances issued around 1st October were mostly temporary withdrawals of teams for various reasons which would take them out of the Village.

Status of villagers: Athletes from a total of 94 countries participated in the Tokyo Olympic Games. The cumulative total number of athletes and officials who stayed at the Olympic Village was 172,610. The peak number of villagers was counted 7,250 on 14th October. A few of these athletes were not registered at the Village by reason of the distance from the sites of the games in which they were participating. (See Page 304)

Events at the Village: The main events at the Main Olympic Village at Yoyogi were the Opening

and the Registering Ceremonies. The Opening Ceremony was held at the central area known as Tokyo Plaza on 15th September and was attended by about 1,200 persons including the diplomatic corps of various countries as well as officials of the Organizing Committee.

The national flags of 98 countries including those which had been expected to participate in the Olympics, the flag of Tokyo and the Olympic flag were hoisted at the Tokyo Plaza, and the colourful Ceremony was conducted impressively.

Registration Ceremonies were held at suitable intervals as the Olympic delegations arrived. The Ceremony was held collectively for a number of teams at a time, and their respective flags were hoisted. As the number of delegations increased more flags were to be seen hoisted at the Village, as the Village gradually assumed its busy activity and international mood. From 26th September to 9th October except for those days when it rained, registration ceremonies were held for the delegations representing 93 countries.

(Note: The Olympic team of Bermuda attended the Registration Ceremony at Oiso Detached Village inasmuch as they were not registered at the Main Olympic Village, its members participating only in Yachting.)

Transportation of athletes and freight: The majority of the Olympic teams entered Japan via the Tokyo International Airport, but some teams arrived at the Village from the port of Yokohama.

Special arrangements were provided to facilitate and simplify their entry procedures, they were transported without delay directly to the Village, either by bus or limousine. From the airport, this involved a ride of some thirty minutes, and from Yokohama some ten minutes longer.

To expedite the transportation of both personnel and freight, a Freight Handling Office and a Transportation Centre (for athletes and officials only) was provided at the Village, to perform the following facilities.

Freight Handling Office: Assigned to this Office were personnel of the Nippon Express, Customs officials, veterinary and agricultural quarantine inspectors, who performed the following services at the time of arrival and departure of Olympic teams.

- Consulting and information service concerning the transportation of baggage and freight in and out of Japan;
- Handling and custody of freight;
- Customs clearance and quarantine of unaccompanied baggage;
- Procedures for delivery of firearms and ammunition;
- Other procedures concerning freight transportation.

Transportation Centre: The Transportation Centre controlled the despatch and scheduling of buses between the Village and the training venues, the Game sites and the Detached Villages. The training venues and Game sites involved some 73 different locations and, to provide adequate transportation facilities, some of the buses were operated from the Village direct to certain of these locations, while shuttle buses were run to make the short, regular trips to others. Shuttle buses were operated between the Meiji Olympic Park and the Komazawa Sports Park at intervals of three to five minutes. Direct buses were operated to the training venues and other Game sites at intervals of ten to thirty minutes. Buses were scheduled from the Village to port of departure as required.

An Information Section was provided at the Service Centre to answer any inquiries concerning Transportation, and a Bus Terminal was operated to centralize the operation of buses. The aggregate number of buses used for transportation of Olympic team members totalled 3,655.

Village transportation: The convenience of transportation within the compounds of the Village itself shuttle buses and bicycles were made available for free use by the Village residents.

Village Shuttle Bus

Village shuttle buses were operated according to the varying number of residents. Shuttle bus runs were made frequently and an average of about 25 persons per vehicle utilized these shuttle buses on each run.

Bicycles

760 bicycles were made available for use by the Village residents and these proved to be most popular in individual movements within the Village.

Traffic regulations within the Village

To maintain order and quiet within the Village and to prevent traffic accidents, the following regulations were enforced:—

- Speed limit 30km/hr.
- Sounding horns not permitted.
- Only those vehicles with official stickers permitted to enter the Village.
- Parking permitted in designated areas only.
- Pedestrians to keep to the right and vehicles to the left.
- Traffic signs were as used on the public streets.

The Service Centre: The Service Centre, located at the main entrance to the Village, provided all the major service facilities and included the Registration Office; Visitor's Lounge; Information Office; Cashier's Window; Bank; Post Office and Telephone and Telegraph facilities. This Centre was strategically placed at the entrance of the Village so that it could service both Village residents and transient personnel including visitors. The ground floor of the Service Centre building was for visiting and press personnel, and the second floor for the Village residents. In front of the Service Centre was the Bus Terminal which provided transportation to and from all game sites and training venues.

Registration Office: Procedures for registering and clearing of each delegation and entry to the Village of visitors and other transient personnel were handled at the Registration Office. Because of the nature of the work involved, this Office remained open 24 hours a day.

Procedures for registering and clearing: The work involving the registration and clearance of athletes was specifically assigned to the following sections:—

- Processing of registrations and clearance. . .
Registration Section
- Gathering and transmittal of information relating to registrations and clearances; Information Centre
- Guiding and information service to incoming Village residents; Service Offices; Women's Quarters

- Change of billet assignments; Billet Assignment Section
- Handling of baggage and freight; Freight Handling Office

Procedures for Village registering and clearing were required in the following cases:—

- a. Procedures for registering were required
 - When an Olympic team initially entered the Village.
 - When Olympic teams or their members who had temporarily left the Village re-entered the Village.
 - When members of Olympic teams who had been staying at the Detached Villages in Oiso, Lake Sagami, Hachioji and Karuizawa entered the Village for a night's stay immediately before their departure.
- b. Procedures for clearing were required
 - When Olympic teams left the Village to return home.
 - When Olympic teams or their members left the Village temporarily.
 - When members of Olympic teams departed for the Detached Villages in Hachioji, Oiso, Lake Sagami and Karuizawa.
 - When members of Olympic teams scheduled to stay at the Detached Villages in Hachioji and the Lake Sagami area stayed overnight at the Main Village at Yoyogi and left the following morning for their respective Detached Villages.

Processing of Village registrations Registrations at the Village were processed efficiently to enable the athletes and officials who had travelled long distances to be taken to their billets and relax without any undue delays. The actual procedures of registration are shown in the figure in this section.

Processing of Village clearances Much of the work involved in the processing of clearances was the actual receiving of notice of clearance from departing Olympic teams. At the peak period of these clearances, Government officials were despatched to the Registration Office to complete the official emigration procedures. This work, however, was independent of the actual clearance from the Village.

Control of Village gates Only authorized personnel were permitted passage through the gates of the Village. Personnel authorized to use the gates were athletes and officials of each delegation, Village employees, persons officially hired by the various Olympic delegations, and approved transient personnel including visitors and press personnel. In principle, transient personnel were required to

check in at the Registration Office. In practice, however, permission was arranged at the Public Reception Room for visitors, athletes and officials, and at the Interview Room for press personnel. The types of passes issued to these personnel and standards applied to the issuance of permits are shown in this section.

Public Reception Room: A Public Reception Room was provided for persons visiting athletes and officials. This served the dual purpose of restricting unwarranted entrance by transient personnel and of giving equal benefit to both the visitor and to the athlete or official. The procedures required for interview are shown below.

The visiting hours were from 10 a.m. to 12 noon and from 2 p.m. to 7p.m. In principle, interviews were arranged in the lobby provided exclusively for this purpose. However, in the case where the chief of mission desired that his visitor be allowed inside the Village, it was arranged that he sign the permit stating that he approved the entry of that visitor, and a special permit was then issued at the Visitor's Lounge. The lobby was in fact more congested than had been expected. Many of the visitors brought gifts and presents for the athletes and officials. In principle, gifts and messages were not accepted at the interview office, but under certain circumstances, however, these were accepted and delivered to the office of each delegation through the Distribution Centre.

Press Interview Room: It was expected naturally that on the days immediately before and after the opening of the Olympic Games, particularly on the day of the opening of the Village (15th September), a large number of radio and television and other news media personnel would come to the Village to cover the Olympic events. From the fact that there were some 4,500 news media personnel from Japan and about 2,000 from abroad, it was to be expected that the Village would be considerably congested both with people and with traffic. The Olympic Organizing Committee, therefore, concluded that its Press and Public Information Division would have to intervene between these reporting personnel and the Olympic athletes and officials at the Village to coordinate their reporting activities. Such action was considered necessary so as not to allow undue interference with the life in the Village.

It developed that in fact there was significantly greater interest shown in the Tokyo Olympic Games by overseas news media than had been observed at previous Olympic Games. It had been anticipated that the number of photographers or press personnel from overseas using these facilities would reach 150

on peak days, but in fact this number exceeded 250. Employees at this Press Interview Room (10 interpreters and 6 staff) were kept most busy by a fairly constant stream of enquiries. Despite the heavy pressure under which they were required to work, the whole information service at the Village was conducted efficiently and without incident.

The success of the information activities at the Village are attributed to a number of reasons. The "Press Interview Room Operating Procedures", were established through careful coordination made in advance between the Organizing Committee and interested information media. All reporters and the personnel assigned to the Village cooperated without reserve with the Organizing Committee in faithful compliance with the formulated procedures. The thoughtful consideration given by the Village authorities to enable the smooth and effective operation of the Village was also a significant factor.

Press Interview Room operating procedures
The Press Interview Room was operated for the purpose of arranging interviews, providing a place for interviews and giving permission of Village entrance to members of press personnel desirous of meeting athletes and officials residing at the main Olympic Village at Yoyogi or who desired to enter the Village for the purpose of gathering news or taking pictures.

The visiting hours at the Press Interview Room and the hours during which news gathering and photo-taking activities were authorized from 8:30 a.m. to 12 noon and from 1 p.m. to 7p.m. each day. All reporters and other personnel of information media within the compounds of the Village were required to leave the Village not later than 8 p.m. No exception to this rule was allowed.

Members of foreign press corps were required to be in possession of their ID cards, and members of the Japanese press corps the Village entrance permits issued by the Olympic Organizing Committee.

Press personnel desiring to interview athletes or officials residing at the Village or to enter the Village for the purpose of gathering news or taking pictures were required to apply for permission to do so by showing their ID cards or Village entrance permits, to the responsible persons of the Press Interview Room and making necessary entries in the Interview Register.

ID cards or Village entrance permits of press personnel were exchanged at the entrance for a Press Badge for exclusive use at the Village. This Badge was returned at the time of leaving the Village in exchange for their ID cards or Village entrance permits.

The Press Interview Room checked the entries made in the Interview Register by visiting members of press corps, notified the office of each delegation

concerned by telephone and kept records of time of their entrance and departure from the Village. Control measures were enforced to prevent too great a number of persons entering at one time.

Upon receiving a telephone call from the Press Interview Room, the responsible official of the delegation concerned (chief of the mission or his representative) informed the Press Interview Room immediately of whether or not he wished to accept the interview.

Coverage of news including the taking of pictures within the compounds of the Women's Quarters was authorized only to woman reporters on certain specified dates and then only during certain specified hours.

No reporting activity was authorized inside of any of the billets or quarters of the athletes and/or officials residing at the Village.

No reporting was authorized within any dining hall during meal times, except on certain specified dates and times.

The Village Club and other facilities at the Village were not to be used for the purpose of holding panel discussions and other gatherings for news reporting.

Village Guide Office: The Information Office was provided for the purpose of offering information and other services to the athletes and officials. The Office operated from 8 a.m. to 8 p.m. The Information Office was divided into three sections: the Village Information Section which provided general information on Village affairs and accepted enquiries and questions concerning the use of various Village facilities; the Training Information Section which was responsible for assignment of training venues; and the Transportation Information Section which provided information on transportation facilities and made arrangements for transportation. Personnel were dispatched from the Olympic Village Division, Sport Technique Division and Transportation and Communication Division. These three Divisions acted together to make the efficient operation of the Village possible.

Village Guide

Numerous inquiries and questions were accepted at the Information Counter and answered on the basis of information and data which had been collected in advance for this purpose. Many questions were seeking directions or regarding communication. Frequent questions were asked as to the Village life, telephone numbers, etc. Inquiries on religions customs in different countries were answered on the basis of the information gathered previously from local shrines and churches. The General Information Section also serviced inquiries involving various aspects of Village life. Applications for sauna baths

and reporting of articles lost and found were also accepted here. Lost articles were processed by personnel despatched from the Metropolitan Police Department. As part of its services to the athletes and officials at the Village, the General Information Section also handled the distribution of admission tickets, Olympic commemorative coins, memorial postage stamps and exchange tickets for Olympic commemorative medals. The services provided by the General Information Section and the numbers of persons handled are shown below.

Training Venues

The Training Information Section was operated by personnel despatched from the Sports Technique Division and from some of the sports organizations concerned. The main service consisted of providing information on training venues and their assignment. Information service concerning the games in general was provided by the Sports Division of the Organizing Committee located in the Kishi Memorial Hall.

Transportation

The Transportation Information Section was staffed by personnel from the Transportation and Communication Division. Applications for transportation of athletes and officials from the Village to the Games sites, training venues and Detached Villages and for transportation at the time of their departure were accepted by this Section. This Section also furnished information on the transportation service.

Cashier's Office:

Cashier services were provided for the benefit of the athletes and officials residing at the Village. The Office, adjacent to the Bank for the convenience of the Village residents, operated from 8 a.m. to 8 p.m. Meal coupons for athletes and officials were issued in exchange for the payment of expenses of each delegation.

Payment of Village expenses

Village expenses of each delegation, including accommodation charges, meal expenses, and for some teams, expenses of grooms and horses, were received collectively by the Cashier's Office.

These expenses were computed on the following basis: ¥2,160 (US\$6.00) per day for each athlete and official, ¥1,800 (US\$5.00) for each groom and ¥1,080 (US\$3.00) for each horse. Village expenses were paid on the basis of the numbers of each delegation residing at one or more of the Olympic Villages as of eleven o'clock a.m. each day. Payment of these expenses were made in advance by the Chief of Mission of each delegation, except at the time of registration at the Village.

The daily number of members of each delegation, on the basis of which its expenses were calculated, was the "Daily Tabulations of Village Residents"

furnished from the Information Centre as well as in the notices of registration or clearance received at the Information Office.

Issuance of meal coupons

Issuance of meal coupons to athletes and officials and all other services related thereto were handled by the Cashier's Office. These meal coupons, as mentioned above, were issued in exchange for the payment of Village expenses. The number of coupons issued was exactly the number of persons and days for which a payment of expenses was paid. The Cashier's Office issued meal coupons only to the residents at the main Olympic Village, and for those residing at the Detached Villages, similar coupons were issued at each of these Detached Villages, based on directions from the Cashier's Office.

The Cashier's Office also handled exchange of meal coupons, (when for instance residents at the main Village took their meals at one of the Detached Villages); the reissuance of coupons when coupons were lost; or issuance of individual special meal coupons for guests or persons other than athletes and officials. At the time of registration, provisional meal coupons enough for at least two days were issued immediately to each member of an incoming delegation to cover the period until the Chief of Mission had procured the coupons on the payment of accruing expenses.

Payment of telegram and telephone charges

Telephone charges were collected for all calls outside the city limits, for long-distance calls and overseas calls. Telephone calls within the compounds of the Village, calls within the city limits and calls between the Olympic facilities or Games sites, or the Detached Villages, were free of charge. Telegrams sent by telephone were also charged.

Bank:

Banking services were available from 8 a.m. to 8 p.m. each day and these were provided by the Nippon Kangyo Bank on the following services:—

Handling of accounts for the delegations and receipt of their payments on behalf of the Organizing Committee

- Receipt of payments of Village expenses
- Receipt of payments of telegram and telephone charges

Money exchange

- Cashing of travellers checks and letters of credit, or exchange of foreign currency brought by members of Olympic teams
- Exchange of Japanese yen for foreign currencies
- Exchange of one foreign currency for another foreign currency

Cash deposits

Money orders

- Foreign money orders
- Japanese money orders

Custody of Valuables

Valuables could be left in the custody of the Bank.

Post Office:

An Olympic Village Post Office was set up to provide postal service for all Village residents from 8 a.m. to 8 p.m. The following specific services were provided.

Mail

All incoming mail was sorted and put in the boxes provided at the Post Office. Direct delivery of mail was not made. Surface mail and air mail (letters) were put in the boxes, but parcels, registered mail, special delivery mail and other special mail were obtainable from the Post Office in exchange for receipts.

Collection of outgoing mail

To facilitate the posting of letters, mail boxes were installed at 17 places within the compounds of the Village.

Sale of postage stamps

Olympic commemorative postage stamps as well as regular postage stamps were sold at the Post Office. Special rubber impression stamps commemorating twenty different Olympic Games were made available for affixing to any outgoing mail.

Local and International Telephone and Telegraph Offices:

A Telephone and Telegraph Office was set up at the main Olympic Village to handle domestic telephone calls and telegrams and an International Telephone and Telegraph Office to service overseas telephone calls and telegrams. These services were available from 8 a.m. to 8 p.m., and for the convenience of athletes, six international telephone lines, five long-distance domestic telephone lines and five public telephone lines were made available.

Telephone and Telegraph Office

The Japan Telephone and Telecommunication Corporation provided domestic telephone and telegraph service at the Village, involving calls by public telephone within the city limits, calls outside the city limits and domestic telegrams. Domestic telegrams were delivered directly to Olympic team offices by the telegraph employees.

International Telephone and Telegraph Office

International telephone calls and telegrams were handled by the International Telephone and Telegraph Corporation (K.D.D.) International telegrams were also delivered directly to Olympic team offices.

Services to each Delegation An Office for each Delegation was provided adjacent to their men's billets. Necessary office equipment and supplies

List of Fixtures in each Delegation Office

Item	Distributed quantity	Distribution standard
Desk with one drawer	2	Cheif de Mission 1 Office 1
Folding chairs	20	Delegation
Portable typewriters	1	"
Multigraphs	1	"
Ashtrays	3	"
Waste baskets	1	"
Stationary	supply	"
Massage stands	1	"
Closet for medicines	1	"
Refrigerator	1	"
Television set	1	"
Radio	1	"

This list is a standard per delegation, and the quantity actually supplied was increased or decreased according to the number of persons in the delegation.

were made available at each of these offices.

Extension telephone lines, from one to a maximum of five depending on the number of members of each delegation, were installed. (One line for every 35 members or less). In the women's quarters, a telephone was provided for each delegation and was installed in the rooms of the chaperone or the chief of mission. One jeep was made available for each of the delegations, regardless of the number of its members, and a total of 180 sedans were also pooled for use by delegations, and these were assigned on the basis of the size of each delegation.

Control and operation of accommodations

Athletes and officials were housed in the existing 4-story concrete billet buildings and the wooden family houses which had been modified to meet the particular requirements for the Olympic Village and these were assigned specifically to each delegation by the Organizing Committee. No complaints were received from any of the delegations with regard to the billet assignments.

Facilities in the billets: On the door of each room, a paper flag signified the delegation to which the occupants belonged. Curtains were furnished in each room to serve also as blinds to enable the occupants to sleep in the daytime if desired. Furnishings and supplies as shown in the Table were provided in each of the rooms.

A bathroom and a kitchen were to be found on each story of the concrete building blocks and in each of the wooden houses. Hot water was supplied in the concrete buildings from the boiler system and in each of the wooden houses by an automatic water heater. In the concrete buildings in the men's housing area, three public bath houses

were newly constructed inasmuch as the existing facilities were not adequate. The number of residents who used these facilities was less than had been expected, but the bath rooms in the wooden houses were used by many and frequently.

Cleaning of Billets and Bed Making: The cleaning of billets and quarters and the making of beds, in addition to environmental maintenance jobs, were entrusted to the Tokyo Building Maintenance Association, which consists of some 56 cleaning and maintenance companies in the Tokyo area, and billets were cleaned each day. Beds for athletes and officials were made daily, and linens (bed sheets, pillow covers) were changed every three days.

Qualifications of cleaning personnel

In view of the fact that cleaning personnel were required to work mostly within the billets, the personal qualifications of these personnel were carefully checked. All these employees were required to have worked for their present employer for at least two consecutive years.

Service Offices:

Because of the difficulty of centralizing the control and operation of the many billets that were scattered over the wide area, the Main Village was divided into seven smaller housing groups, in each of which were accommodated a number of delegations representing countries of the same or similar language and customs. A Service Office was set up in each of these areas, and staffed by some 25 men (19 from the Ground Self-Defense Force, 4 interpreters and 2 service women) and these personnel worked on two or three shifts. Before being assigned to their respective jobs, these personnel received training in the language, national affairs, life, customs and other aspects of the country or countries of the residents in the area of their assignment.

Receiving of the delegations

Some Service Office personnel were each time sent to the Registration Office to meet the newly arrived athletes at the Village, to take them to their delegation office. Assignments of rooms among the newly arrived athletes and officials were left to the discretion of the delegation to which they belonged. Many of the Village registrations were made very late at night or past midnight, and Service Office personnel on these occasion served them night snacks. The period from 25th September to 10th October, was particularly busy, handling the arrivals of delegations.

Distribution of printed matter

A total of 8,222 items of printed matter was distributed to the delegations. These included guides to the Games, information on transportation facilities, invitation cards, flashes on game results, Village newspapers. Service Offices in charge of the

areas that housed many delegations of different nationalities handling this unexpectedly large volumes of printed matter, required additional personnel to be assigned to these Offices from 10th October onward.

Sewing and ironing service

Assigned to each Service Office were two or three service women who perform duties of ironing, sewing and other minor mending work. All of these were experienced housewives, and their very satisfactory service won highly favourable acceptance among the athletes and officials. The total number of assignments for sewing and other mending work was 1,543 (596 for the Women's Quarters), that for pressing 2,076 (760 for the Women's Quarters), and some 3,000 for attaching identifying numbers to sports clothing, etc.

Supervision of cleaning and bed making

The personnel engaged in billet cleaning and bed making were supervised to ensure satisfactory results of operation.

Delivery and supply of goods

Responsible personnel were always present at the time of delivery of furnishings and expendable articles leased or supplied to the delegations. Service Offices were also responsible for supply service.

Maintenance of billets and other facilities

All requests made by the delegations for repair and maintenance work in the billets and other facilities were promptly referred to the responsible sections for immediate action. The total number of orders accepted for such repair and maintenance was 1,737.

Custody of keys

Three identical keys were provided for each room. One was for personal use, and the other two were put in custody at a Service Office for use by cleaning personnel, etc.

Admissions to athletes villages by country

NOC	Athletes, officials						Grooms			Horses		
	Yoyogi	Hachioji	Oiso	Lake Sagami	Karui-zawa	All Villages	Equestrian Park	Karui-zawa	All Villages	Equestrian Park	Karui-zawa	All vil-lages
Afghanistan	11					11						
Algeria	1					1						
Argentina	(8) 128					(8) 150	6	3	6	10	5	10
Australia	(43) 248	13	4			(46) 298	(3) 6	(3) 4	(3) 6	11	6	11
Austria	(11) 64	16	15	(3) 12		(12) 76						
Bahamas	4		5	(1) 7		4						
Belgium	(1) 61					(1) 78						
Bermuda		13	2	2		(2) 8						
Bolivia	1		(2) 8			1						
Brazil	(1) 75					(1) 80	1		1	2		2
British Guiana	3		5			3						
Bulgaria	(7) 83	1				(7) 88						
Burma	16			(1) 4		16						
Cambodia	10	11				27						
Cameroons	1		6			1						
Canada	(21) 121			8		(2) 141	(1) 2		(1) 2	2		2
Ceylon	7		12			7						
Chad	3					3						
Chile	21					21	1		1	1		1
Colombia	(3) 23	10				(3) 33						
Congo	3					3						
Costa Rica	2					2						
Cuba	(3) 45					(3) 45						
Czechoslovakia	(10) 123	10	1	(1) 5		(10) 139						
Denmark	(5) 45	17	(1) 15	(2) 9		(5) 86						
Dominican Republic	2					2						
Ethiopia	11	5				16						
Finland	(7) 113		5	4		(7) 122						
France	(22) 155	23	5	3	(1) 8	(22) 194	(1) 4	(1) 4	(1) 7	8	5	8
Germany	(80) 438	21	21	(5) 19	6	(85) 505	(1) 10	4	(1) 11	17	6	17
Ghana	(4) 45					(4) 45						
Great Britain	(49) 220	16	14	(1) 7	8	(50) 265	(3) 6	(1) 3	(3) 7	10	5	10
Greece	20		6			26						
Hong Kong	(1) 38	4	6			(1) 48						
Hungary	(35) 226	9	2	(3) 19		(38) 256						
Iceland	(1) 5					(1) 5						
India	(1) 68	6				(1) 74						
Iran	(6) 78	5				(6) 83						
Iraq	27		5			27						
Ireland	(1) 28				(1) 7	(2) 40	(1) 4	(1) 4	(1) 4	5	5	5
Israel	(2) 15		12			(2) 15						
Italy	(13) 191			7	5	(13) 215	8	4	8	11	5	11
Ivory Coast	12		3			12						
Jamaica	(6) 23		14			(6) 26						
Japan	(62) 369	18	2	(2) 14	4	(64) 419	9	4	9	17	5	17
Kenya	47					49						
Korea	(28) 210	8			6	(27) 224	1		1	8	4	8
Lebanon	7					7						
Liberia	6					6						
Liechtenstein	3					3						
Luxemburg	(2) 15					(2) 15						
Madagascar	4					4						

Admissions to athletes villages by country (Cont.)

NOC	Athletes, officials							Grooms			Horses									
	Yoyogi	Ha-chioji	Oiso	Lake Sagami	Karui-zawa	All Villages	Equestrian Park	Karui-zawa	All Villages	Equestrian Park	Karui-zawa	All Villages								
Malaysia	(6)	83	10			(6)	93													
Mali		4					4													
Mexico	(6)	114	12	10		9	(6)	145	6	3	6	10	5	10						
Monaco		2					2													
Mongolia	(5)	27	6				(5)	33												
Morocco		36					36													
Nepal		10					10													
Netherlands	(24)	134	20	10	8		(24)	172												
Neth. Antilles		7					7													
New Zealand	(10)	75	6	6			(10)	87	2		2	4		4						
Niger		3					3													
Nigeria	(3)	25					(3)	25												
North Rhodesia	(1)	15					(1)	15												
Norway	(2)	25		13			(2)	38												
Pakistan		55	6				61													
Panama	(4)	17					(4)	17												
Peru	(1)	40	1				(1)	41												
Philippines	(10)	61	5	6			(10)	72												
Poland	(27)	170	10		(3)	13	(30)	193												
Portugal	(3)	25		6			(3)	31	2		2	2	2	2						
Puerto Rico	(3)	45		1			(3)	46												
Rhodesia	(4)	32		(1)	5		(5)	37												
Rumania	(34)	178	8		(4)	19	(38)	205												
Senegal		16					16													
Spain	(3)	78	12	2			(3)	92	4		4	4		4						
Sweden	(18)	101	7	15	(2)	12	(20)	135	2		2	3		3						
Switzerland	(1)	75	6	11			(1)	92	5		5	8		8						
Taiwan	(5)	55	7				(5)	62												
Tanganyika		6					6													
Thailand	(8)	64	14	(4)	8		(12)	86												
Trinidad & Tobago		12	5	3			20													
Tunisia		17					17													
Turkey		31		4			35													
U. A. R.		99					99													
Uganda	(2)	20					(2)	20												
Uruguay		24	11				35													
U. S. A.	(91)	407	18		(3)	13	(1)	7	(95)	445	(2)	9	(2)	4	(2)	11	14	5	14	
U.S.S.R.	(72)	421	23	17	(5)	21		6	(77)	488	6	2		6	14	6	6	14		
Venezuela	(1)	20		3			(1)	23												
Viet Nam		21	9				30													
Yugoslavia	(3)	91				5	(3)	96												
All villages (93 countries)	(780)	6,184	404	(8)	286	(36)	218	(3)	78	(826)	7,152	(13)	74	(8)	39	(13)	100	157	63	161

Figures in parenthesis are those for the women's village. The total village entries do not necessarily coincide with the total participants from each country. These figures have been compiled from the maximum entries in any village.

**Graph showing numbers of persons admitted to villages
(Athletes, Officials, Grooms)**

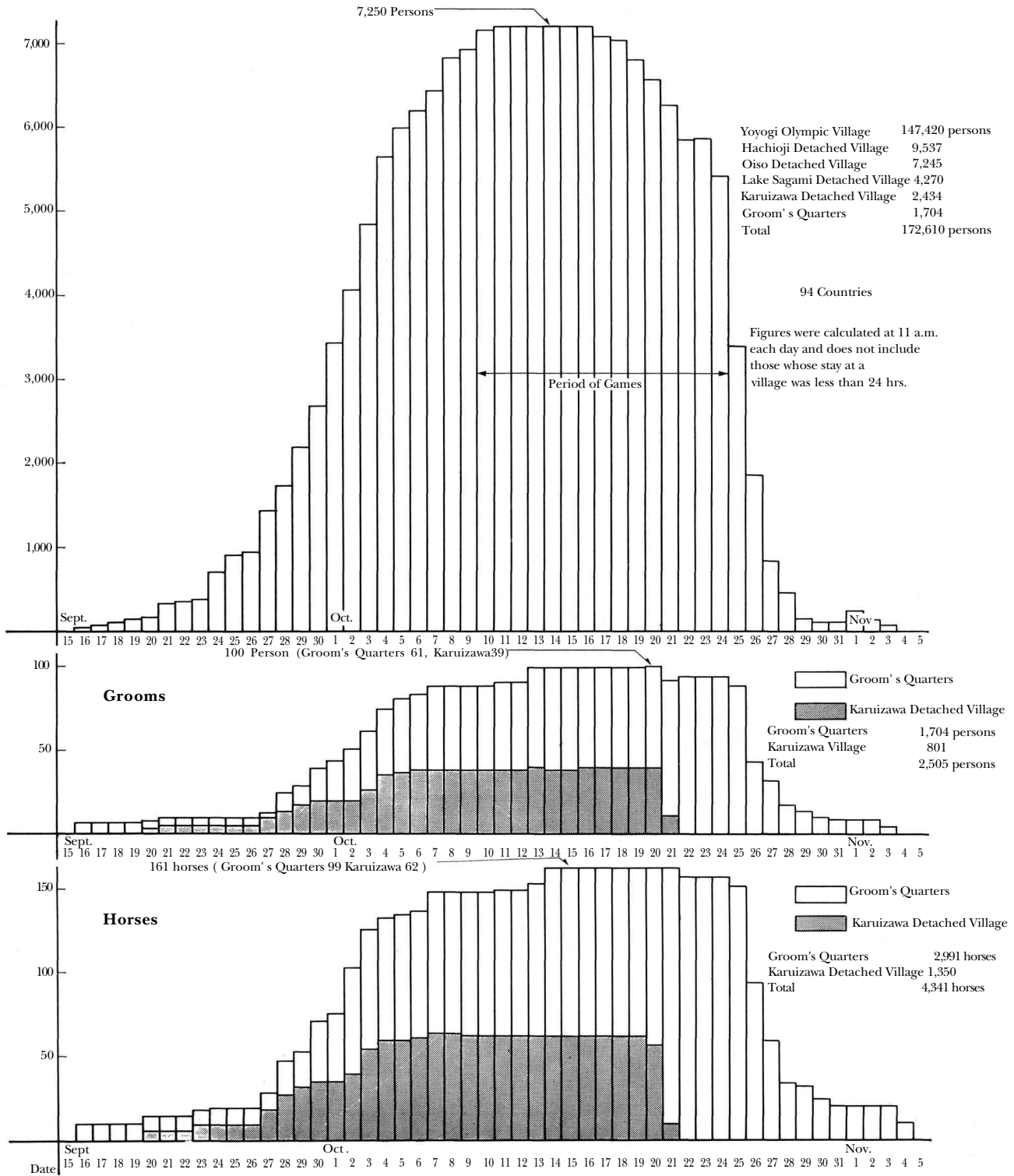

Women's Quarters

The Women's Quarters were conducted by a Women's Quarters Service Office, a branch of the Olympic Village Division, and staffed entirely by female employees. The services provided by this office may be divided roughly into the service performed by the Service Offices and the service characteristic of the operation of a Women's Quarters. A Service Office was provided for each of the buildings in the Women's Quarters, and this functioned under the direction of the Women's Quarters Service Office.

Major services provided for the operation of the Women's Quarters were as follows:—

Control of entrance: For the purpose of ensuring privacy in the Women's Quarters, no personnel, other than the female employees assigned thereto, were permitted to enter. Gates to the Women's Quarters were established at three points, and Ground Self-Defense Force personnel were assigned to each to ensure that only authorized personnel

were admitted. A special entry permit was issued when any man was required to enter the Women's Quarters in line of duty, and when authorized, any transient visitor to this area was always accompanied by a police woman.

Control and operation of Women's Quarters Centre: Facilities at the Women's Quarters Centre included a dining hall, lounges, shops, information office, beauty parlour, and laundry and dry cleaning service. These facilities were controlled and operated by the Centre.

Lounge

Two lounges were provided in the Women's Quarters Centre. Newspapers, magazines, records and players, a piano, coffee stands, etc. were furnished in the lounge to provide comfort and enjoyment for the women athletes and officials. Special programmes were given two or three times a week in certain areas of particular interest. Most popular of these programmes was the demonstration of how to wear a 'kimono', which was held three times during the Olympics at the request of women athletes and officials.

List of Persons admitted to enter Women's Quarters

Certificate issued	Standard	Object	Remarks
Gate Pass	Person who carried on work in Women's Quarter and required to enter the village every day.	Beautician, shop girl, waitress, female clerk for delegation, cleaning concerned, restaurant concerned, linen supply concerned, utensils and commodities supplier, sanitary inspector, flower arrangement concerned.	
Women's Quarters (Temporary admission badge, Temporary admission pass)	<p>Person who required to enter the village temporary for the work</p> <p>Visitors to athletes or official, with special permission of the leader</p> <p>Persons especially permitted by Director of Yoyogi Village</p> <p>Persons who entered at a special interview day for collecting news of Women's quarters</p> <p>Person who wished to interview to female athletes and officials for collecting news in Women's Quarters, and in possession of special interview permission</p>	<p>Headquarters' staff, fire inspector, construction engineer, team doctor, clinic's doctor, head nutritionist of delegation.</p> <p>Visitors</p> <p>Leader of delegation, guests</p> <p>Japanese woman press concerned</p> <p>Japanese woman press concerned Foreign woman press concerned</p>	<p>Policewoman or staff was also present</p> <p>Staff member also present</p> <p>Staff member conducted visitors</p> <p>Admittance of press concerned to quarters was strictly prohibited.</p> <p>Policewoman or staff member was present.</p>

Note: This list indicates persons who were permitted to enter the village, in addition to the assigned personnel (103 females) in Women's Village.

There was a General Information Counter in the lounge, but the number of people who used this facility was less than had been expected, and enquiries only averaged some ten a day.

Shops, Beauty Parlour and Laundry and Dry Cleaning Service

Various women's articles were sold at small shops set up at the Women's Quarters Center. A total of 2,393 residents or an average of 46 women a day utilized the beauty parlour.

Laundry was accepted at a window provided at the Women's Quarters Centre, but actual laundry service was given by a laundry and dry cleaning service in the men's quarters.

Women's dining hall

Not many actually used this dining hall, inasmuch as the women athletes and officials were permitted to use the dining halls in the men's quarters.

Quarters for women employees

Sleeping quarters were provided for the benefit of all women employees working at the Village, so that those whose assignments were in the men's housing area could also use these facilities.

Control of bath houses and steam baths:

In addition to the bath rooms, shower rooms and laundry facilities provided in individual quarters, public bath houses and steam baths were newly constructed for the Games.

Women athletes and officials were able to use not only these facilities but also some of the facilities in the men's housing area. This accounts for the fact that some of the facilities in the Women's Quarters were not used as frequently as had been originally expected.

Security guards:

Ten police women were always on duty in the Women's Quarters.

Equestrian Park annex

During the peak of the equestrian games, 94 grooms representing 20 countries were housed at the billets at the Equestrian Park. Two wings of billets, one for men and the other for women, were constructed adjacent to the Park stables, and a dining hall, a registration office, an administrative office and several other related facilities were annexed to the billets.

The Equestrian Park annex was controlled and operated in much the same way as was the main Olympic Village at Yoyogi. The services provided at this site were divided, as was the case with the Women's Quarters, into those performed by the Service Office and those which were specially required for the operation of the Equestrian Park annex.

First Floor Plan of Women's Village Centre

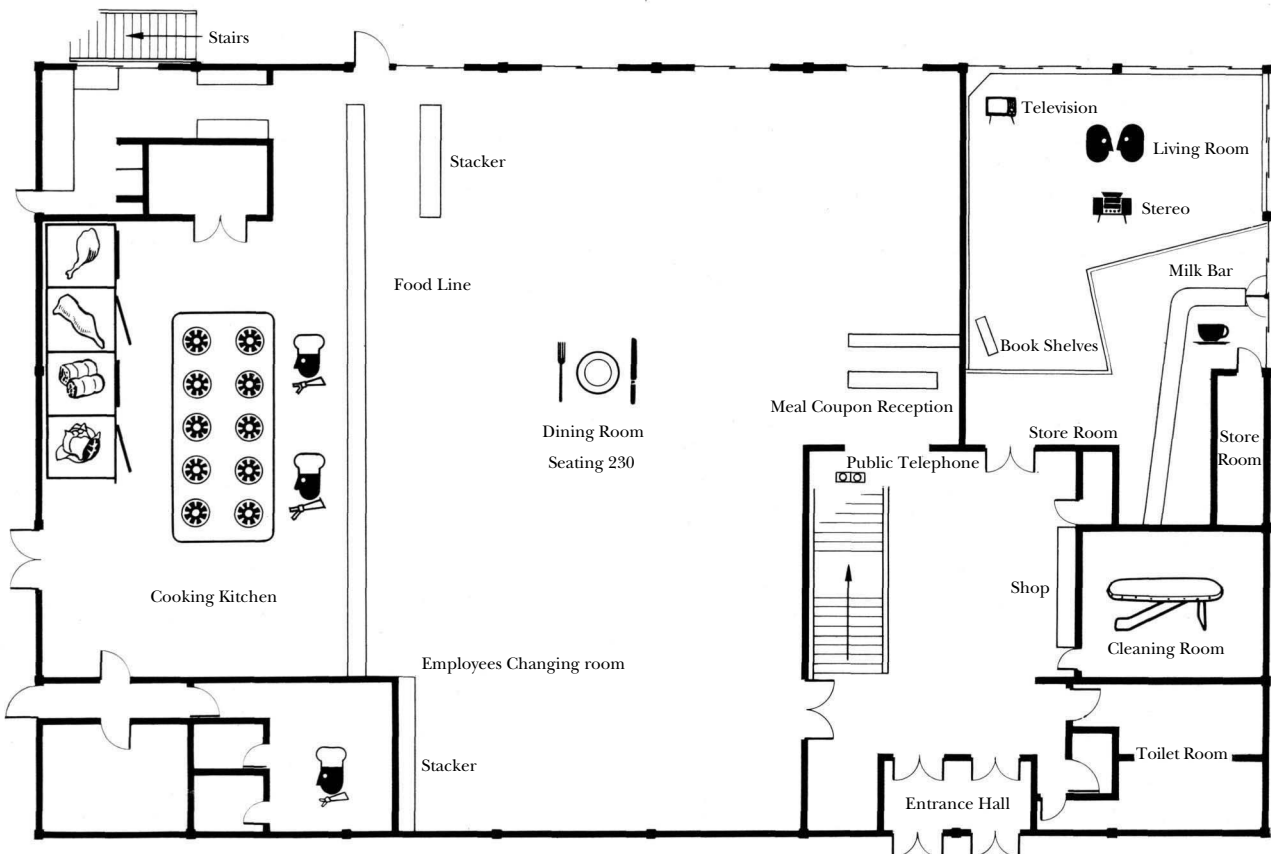

Registration Office and Information Office:

A Registration Office and an Information Office were annexed to the equestrian billets and operated in much the same way as was the main Olympic Village at Yoyogi.

Dining Hall:

A dining hall with a capacity for 36 persons was provided in the men's billets. Semi-cooked food was transported from the women's dining hall at Yoyogi; and was heated or prepared at this dining hall.

Bank and Postal service:

Personnel of the Nippon Kangyo Bank and the Tamagawa Post Office were on duty daily at this site to provide banking (mainly money exchange) and postal services.

Clinic:

Although the clinic at the Olympic Village was available, special arrangements were made with some of the hospitals in the neighbourhood (Tamagawa Hospital and Okura Hospital) to provide efficient medical service where required.

Stables:

Four wings of stables, each having a capacity for 40 horses (a total of 160 horses), were newly constructed. A total of 157 horses—133 for the equestrian games in Tokyo area and 58 transferred from Karuizawa after the 3-day events—were fed and

housed in these stables. Veterinary, shoeing and quarantine inspection facilities were also provided in the stables.

Fodder and certain horse equipment were supplied to the participating delegations. Also provided were such services as treatment of sick horses, shoeing and quarantine inspection. All horses were transported by special trucks from the port of entry directly to the equestrian park annex. Operation and control of stables was the responsibility of the Equestrian Sports Operation Office.

Maintenance of village facilities and security service

The efficient maintenance and repair of Village facilities, supply of goods, maintenance of telephones, cleaning and medical service were essential to the comfortable Village life of Olympic athletes and officials.

Security services within and outside the compounds of the Olympic Villages was important, though inconspicuous, in providing security and preventing any possible incidents in the Village.

Maintenance and repair service:

Most of the existing buildings and other structures at the main Olympic Village at Yoyogi had been well used. In order therefore to make the best use

Second Floor of Women's Village Centre

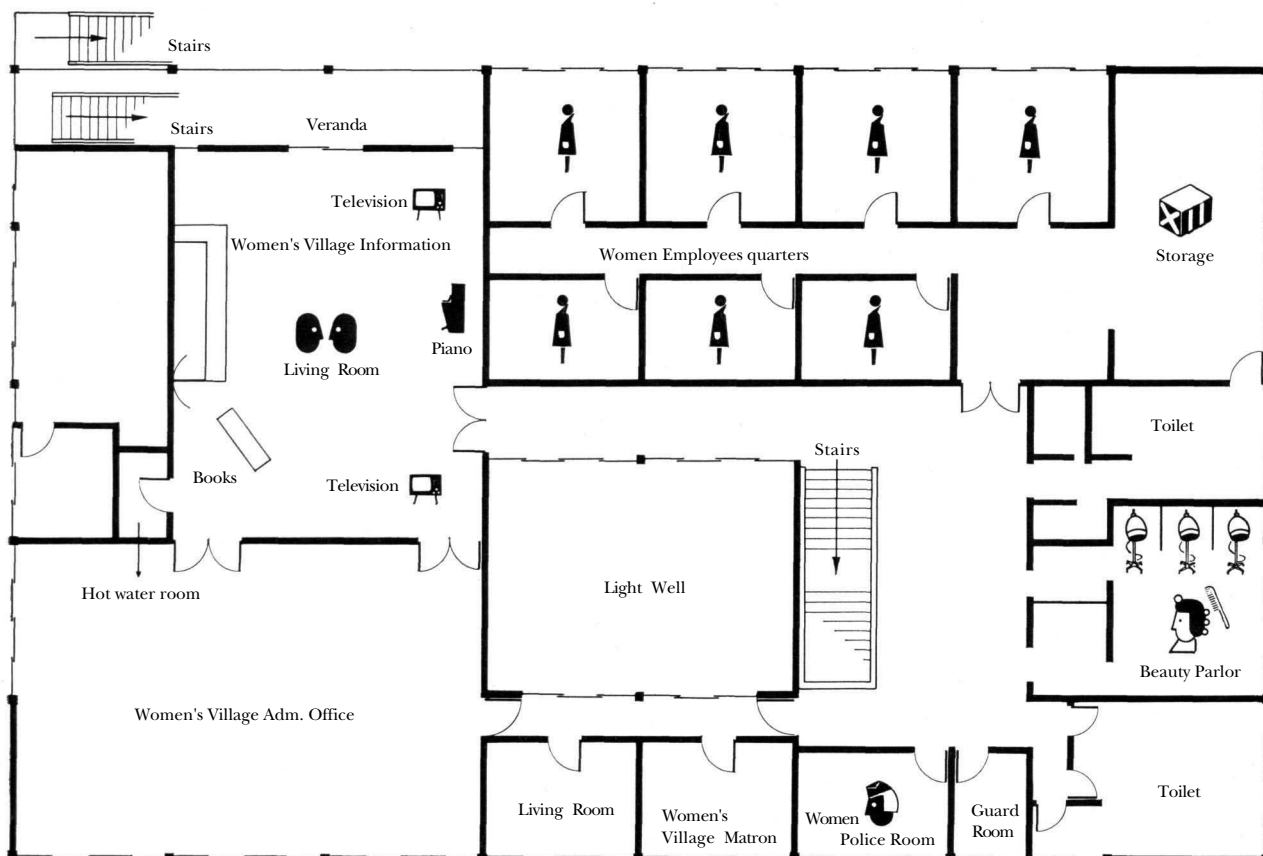

of these structures, special consideration was given to the matter of maintenance and repair.

Major facilities that required maintenance and repair are shown in Table. Technically qualified personnel were mobilized to repair and maintain these structures, and maintenance and repair service was entrusted to outside organizations. Repairs executed and personnel employed are shown in Table. Orders for repairs were processed and repair work was carried out in accordance with the procedures shown in Figure.

Numbers of cases of repair and types of repairs are indicated below. Numbers of cases of repairs per day is as shown in Figure. Water pipes and roofs were the areas most involved.

Repairs to buildings and structures	568	
Electrical repair	85	
Water supply and drainage	562	
Others	44	
Total	1,259	cases

On 25th September a typhoon hit the Tokyo area and some damage occurred in some of the Village facilities. Repair of the damage facilities was accomplished effectively by the Ground Self-Defense Force personnel assigned to the Village.

Control and supply of goods:

Supply and control of goods during the operation of the Village was the responsibility of the Property Control Branch of the General Affairs Section of the Olympic Village Administration Office.

Goods leased to Olympic officials were supplied, additionally repaired or newly leased upon request through the Service Offices in the men's quarters and through the Women's Quarters Service Office. Additional requests for supply or repair were then referred to a supply office warehouse where four trucks and ten personnel were maintained on duty.

Cleaning service:

Disposal of rubbish at the Village including waste packages, waste paper, used tea leaves, fallen leaves and waste paper in the open area, and garbage from dining halls, was contracted for by an outside organization.

Cleaning in and outside the annex

Cleaning both in and outside the annex and other facilities, together with bed making, was entrusted to the Tokyo Building Maintenance Association.

The cleaning work involved cleaning the annex and joint-use facilities (including cleaning of corridors, stairways, toilets and window panes) and cleaning the Village grounds (such as removal of fallen leaves). The rubbish collected as the result of this cleaning operation was placed for disposal in the large plastic buckets placed at intervals of 100 metres along the streets.

A total of 673 cleaning personnel (including four

at the Equestrian Park Annex), in addition to a certain number of replacement personnel, were assigned to the main Olympic Village. The aggregate of personnel despatched from the Tokyo Building Maintenance Association totalled 38,636 for a period of 54 days or an average of 715 per day. Of this number, 15,450 were men and 23,186 were women.

Methods and frequency of cleaning are shown in the Table.

Disposal of rubbish

The rubbish collected in the plastic buckets were carried out of the Village compounds by trucks of the Metropolitan Sanitation Bureau. During the peak of the cleaning operation six trucks daily were used, and during the periods before and after this, 2 to 4 trucks were required daily.

Garbage disposal

Garbage from the dining halls during the peak period from 26th September to 20th October was as much as to fill 16 to 20 drums (each having a capacity of 200 litres). During the rest of the period some five drums of garbage daily were produced. These drums were collected in a garbage shed near the dining hall, from which they were carried outside of the Village three times a day during the peak period and once a day during the rest of the period.

Others

The lawns were mowed three times in June, two times each in July and August and once each in September and October. The mowing was entrusted to a contractor.

Telephones:

A Telephone Exchange Office was set up at the Village to provide around-the-clock telephone exchange service for the Delegations. The Village telephone system consisted of 100 exchange lines and 650 extension lines. Installed in addition to these lines were special lines for the Organizing Committee, direct dial line telephones, and special exchange lines which were paid for by the various contractors at the Village. An interphone system was installed to connect the Olympic Village Administration Office and the Service Centre to enable rapid and effective communication between these Offices. In addition, public telephones were installed for the convenience of general visitors. Ten switchboards were installed at the Telephone Exchange Office, and all operators were able to speak both Japanese and English. When there was a call in a language other than these, the operator connected the call to the interpreters at the Registration Office.

Calls outside the city limits, domestic telegrams and overseas calls from the office of each delegation via extension lines were all handled through the Exchange. The total number of calls handled.

through the Exchange was about 10,000 daily (of which some $\frac{1}{4}$ were in English) during the period from 16th to 25th October. The highest number recorded in a day during this period was 12,853.

Environmental sanitation:

Particular attention was paid to the matter of environmental sanitation to ensure the health of athletes and officials. This was carried out, not only at the Village itself but also in the area around the Village, under the general control of the Medical and Sanitary Section of the Stadium and Ticket Division of the Organizing Committee. Prior to the opening of the Village, the entire compounds of the Village and its facilities were disinfected and insects and rodents were exterminated with the cooperation of the Metropolitan Sanitation Bureau. During the operation of the Village, chemicals were sprayed throughout the Village to maintain insect control.

Security service:

A total of 379 Ground Self-Defense Force personnel were assigned to the Village to handle the security service in and around the Village. Their primary duties consisted of guarding the Village gates and patrolling the Village compounds.

Guard duty at the Village gates

There was one main gate on the border of the Village and three smaller gates leading to the women's quarters.

Guards of the GSDF checked each person or vehicle passing through the gates to ensure that each had a permit or that no property was carried illegally out of the Village compounds.

Patrolmen performed patrol duty within the village compound to apprehend any intruders or to prevent any possible theft or fire.

Security in the village area:

Security service in the area surrounding the Village itself was provided by a total of 132 security guards despatched from the Metropolitan Police Department. In case of emergency, these security personnel could be mobilized at the order of the Village Director. No such occasion arose, however, and these personnel were occupied primarily with traffic control, and patrolling outside the Village.

Fire service:

A fire station was set up by the Shibuya Fire Department, and two fire trucks and 64 firemen were made available. In addition, a voluntary fire defense group was organized from village personnel and fire alarms and extinguishers were installed at all the potentially dangerous spots. There was fortunately, however, no outbreaks of fire at the Village.

Food service

Dining halls were operated on the principle of serving the athletes and officials with the kind of food that best suited their dietary customs and yet contained sufficient calories and nutrition to adequately maintain their health and physical fitness. Pleasant and comfortable environments were provided in the dining halls.

Basic policy of operation of dining halls:

Dining halls were operated in accordance with the following basic policy.

In order to operate international and sufficiently large scale dining halls, extensive experience, knowledge and ability concerning food service were essential requirements. It was thus decided that the most practical way to operate these dining halls would be to request the service of the Japan Hotel Association of which the leading Japanese hotels in Japan are members. The work entrusted to this Association consisted of the following:—

- Preparation and serving of food and beverages
- Procurement and storage of supplies
- All matters concerning dining hall employees, including hiring, training and payment of wages
- Procurement of cooking utensils and tableware (excluding large cooking equipment)

Dining halls were operated at two different points to reduce costs, one in the men's quarters where two dining halls (Fuji and Sakura Dining Halls) with a capacity for about 1,000 persons were newly constructed, and the other in the women's quarters where the existing building with a capacity for 230 persons were modified to meet the requirements of the delegations. At each of these dining halls the furnishings listed in the Table were provided.

Each of the dining halls in the men's quarters were subdivided into six rooms with a capacity for 168 persons each. Thus, a total of 12 dining rooms were available. The delegations were divided also into 21 groups according to their dietary customs or preferences and one dining room was specifically designated for each group. In addition, for the convenience of those athletes and officials who could not take meals during the regular meal times on account of their particular game or training arrangements, an International Dining Room was provided.

For the purpose of storing and pre-cooking raw food, one food supply centre equipped with refrigerators was constructed. The refrigerators had a capacity to store a 2-3 days' supply of food.

To ensure effective operation of dining halls, a meal coupon system was adopted. Standard menus contained at least 6,000 calories and the cafeteria

system allowed a free choice of food. Regular menus including a wide range of internationally accepted dishes and special menus containing dishes characteristic of each country were prepared.

Preparation of dining halls:

Planning for the operation of dining halls started in April of 1963 and by 15th September, the day of the Opening Ceremony, all the dining halls were in complete readiness.

Organization of dining halls:

The dining halls were organized as shown in Figure.

General status of operation:

In view of the fact that as many as 7,000 athletes and officials representing 94 countries each with different dietary customs and preferences were required to be fed, it was expected naturally that there would be some complaints regarding some of the menus. Actually, however, there was no com-

Dining Room Allocation List

Fuji Dining Hall

1	2	3	4	5	6
Pakistan 55	Philippines 61	Mexico 114	Japan 369	Finland 113	New Zealand 75
Burma 16	Korea 211	Brazil 75	Taiwan 55	Iceland 5	Australia 248
Iran 78	Hong Kong 38	Chile 21	Malaysia 83	Ireland 24	Canada 121
Iraq 27	Ceylon 7	Panama 17		Norway 25	Spain 78
Turkey 31	Jamaica 23	Venezuela 20		Sweden 101	Portugal 25
Nepal 10	Bahamas 4	Costa Rica 2		Netherlands 134	
Lebanon 7	British Guiana 3	Uruguay 24		Netherlands	
Viet Nam 21	Trinidad & Tobago 12	Bolivia 1		Antilles 7	
Cambodia 10	Algeria 1	Peru 40		Yugoslavia 91	
Taiwan 61	Chad 3	Cuba 45		Switzerland 75	
India 68	Niger 3	Dominican Republic 2		Greece 20	
Ethiopia 11	Ivory Coast 12	Puerto Rico 45			
Israel 15	Cameroons 1	Argentina 129			
	Mali 4				
	Senegal 16				
	Tunisia 17				
	Morocco 36				
Total: 410	Total: 452	Total: 535	Total: 507	Total: 595	Total: 547

Note: In addition to the Fuji Dining Hall, the International Dining Hall could be used after normal Dining Hours. Above figures include Male & Female totals.

Sakura Dining Hall

1	2	3	4	5	6
U.S.S.R. 421	Hungary 227	Germany 438	U.A.R. 99	U.S.A. 408	France 156
Czechoslovakia 123	Poland 170	Denmark 45	Uganda 20	Great Britain 220	Belgium 61
Bulgaria 83	Rumania 178	Austria 64	Ghana 45	Colombia 23	Monaco 2
Mongolia 27		Liechtenstein 3	Tanganyika 6		Luxemburg 15
			North Rhodesia 15		Italy 191
			Kenya 47		
			Rhodesia 32		
			Nigeria 25		
			Liberia 6		
			Afghanistan 11		
			Madagascar 4		
			Congo 3		
Total: 654	Total: 575	Total: 550	Total: 313	Total: 651	Total: 425

Note: During the actual Games period, the International Dining Hall could also be used. Figures include total Male & Female usage.

plaints and the food served appeared to be generally favorably accepted among the athletes and officials.

Assignment of dining halls

Fuji Dining Hall

- Breakfast (Fuji Dining Room No. 2)
- Lunch (Fuji Dining Room No. 4)
- Supper (Fuji Dining Room No. 6)

The basic policy in operating the dining halls was to divide the delegations according to their dietary customs and assign them then to the nearest dining hall.

The International Dining Room which was operated during the non-regular meal time was arranged as follows.

An International Dining Room was also provided in Sakura Dining Hall to provide meal at irregular hours during the games:

Sakura Dining Hall

- Breakfast (Sakura Dining Room No. 3)
- Lunch (Sakura Dining Room No. 4)
- Supper (Sakura Dining Room No. 1)

Period of food service

Food service was provided from 15th September to 5th November. Nobody was present at any of the dining halls for breakfast on the morning of 15th September and for supper in the evening of 5th November.

Meal time

Time schedules for meals were made, as shown in the Table, in due consideration of the game and

training schedules.

Service at the dining halls

The dining halls were operated in cafeteria style. Salads, cold dishes, hot dishes, fruit, tea, coffee, juice, etc. were served at the counter. Milk, ice-cream, water, etc. were kept for free service in the various coolers in front of the counter. Tableware such as saucers, plates, spoons, forks and knives were arranged also on the counter. Most of the dining hall service personnel did the clearing and washing of dishes, and the cleaning of dining tables. This routine work was done by students selected from among the Travel or Hotel Clubs at the various universities.

Each athlete or official entering the dining halls was required to submit his or her meal coupon at the front desk. However, in certain special cases, such as where coupons had been lost, the athlete or official concerned was permitted to take his meal after completing certain necessary entries in the prescribed form available at the front desk.

Personnel other than athletes or officials, who had been authorized by the Village Director, were also permitted to take meals at the dining halls. The cumulative total number of such personnel was 9,275. No alcoholic beverage was served at any of the dining halls, except when such drinks were brought in by the individuals themselves.

Special food

• Box lunches

Box lunches were prepared for those who could not eat at their dining hall by reason of their travel to distant Games sites or training venues. Two menus were always available for box lunches, and anybody could take with him a thermos bottle of soup, coffee or tea together with his lunch box. The total number of box lunches served was 6,318.

• Diets for patients

Special diets were served to patients hospitalized at the Village Clinic under the direction of doctors. A total of 259 special meals were served to such patients.

Menus

A complete list of menus was prepared for the whole period of the Olympics. These menus consisted of regular and special menus prepared to supplement the regular menu. The regular menu shown in Table were common to all dining halls, but special menus varied from one dining hall to another, depending on the dietary customs of the delegations. When there was any particular request regarding menu, it was discussed in detail with the person making the request so that as far as possible his desire could be met.

Cooking

Semi-cooked food from the food supply centre was prepared in the kitchens of the dining halls.

Table showing Meal-hours at Dining Hall

Dining Hall	Meal	Before & After Games		During Games		
		Hours	Table time	Hours	Table time	
Fuji, Sakura and Women's Dining Hall	Breakfast	7.00~9.30	2.30	7.00~9.30	2.30	
	Lunch	11.30~14.00	2.30	10.30~14.30	4.00	
	Evening	17.30~21.00	3.30	17.30~21.00	3.30	
					8.30	10.00
	Day of Opening Ceremony				7.30~9.30	2.30
					10.30~13.30	3.00
					16.30~21.00	4.30
						10.00
	International Club	Breakfast	{ 6.00~7.00 9.30~11.00		{ 6.00~7.00 9.30~10.30	
		Lunch	{ 11.00~11.30 14.00~17.00		14.30~17.00	
Evening		{ 17.00~17.30 21.00~24.00		{ 17.00~17.30 21.00~24.00		
				Day of Closing Ceremony		
					{ 6.00~7.00 9.00~13.00	
					{ 13.30~16.30 21.00~24.00	

Supply of raw food
 Raw food was delivered from outside the Village to the food supply centre where several days' supply of raw food was put in storage. After preliminary cooking, the food was loaded on five trucks for delivery to each of the dining hall.

However, supplies such as milk, ice cream, soft drinks or uniforms, which had to be supplied daily

from outside the Village, were delivered directly to each of the dining halls. During the peak activity, the food supply centre was filled to capacity making it difficult to operate in accordance with the established procedures. Items, therefore, which did not require preliminary cooking at the supply centre, such as fruit and dried food, were delivered directly to each of the dining halls.

Menus used at Olympic Village

	Table d'hote	Standard list
Breakfast	Orange juice, Pineapple juice, Tomato juice, Grape juice, Oatmeal, Corn flakes, Fried eggs, Boiled eggs, Omelet, Scrambled eggs, Poached eggs, Ham, Bacon, Sausage, Toast, Breakfast rolls, Jam, Butter, Marmalade, Tea, Milk, Cocoa, Coffee	Orange juice, Tomato juice, Pineapple juice, Grape juice, Grapefruits juice, Milk, Cocoa, Coffee, Tea, Sanka coffee, Oatmeal, Corn flakes, Toast, Breakfast rolls, Jam, Butter, Marmalade, Eggs, Bacon, Ham, Sausage, Cheese, Cold meat
Luncheon and Dinner	<p>(Typical example-1)</p> <p>Hors d'oeuvres and cold buffet, Consomee or veloute, Supreme of salmon anglaise, Grilled chicken, Maitre d'hotel, Buttered strig beans, French fried potatoes, Mushroom saute, Desserts, Cheeses, Fruits, Coffee, Tea, Sanka coffee, Milk, Bread, Rice</p> <p>(Typical example-2)</p> <p>Hors d'oeuvres and cold buffet, Cream of chicken soup, Consomme, Fillet of halibut au gratin, Fried prawn with lemon, Veal schnitzl viennoise, Roast chicken with liver dressing, Lyonnaise potatoes, Baked potatoes, Celery au jus, Buttered spinach, Coffee, Tea, Sanka coffee, Milk, Bread, Rice</p>	<p>"Hors d'Oeuvres and Cold Buffet"</p> <p>Ham, Sausage, Corned tongue, Stuffed eggs, Tuna fish, Oil sardine, Fish salad, Combination salad, Chicken salad, Roast beef, Roast chicken, Roast veal, Roast lamb, Roast pork, Tomatoes, String beans, etc.</p> <p>"Potages"</p> <p>Consomme, Veloute, Creme, Vegetables, etc.</p> <p>"Fish"</p> <p>Prawns, Salmon, Halibut, etc.</p> <p>"Meats"</p> <p>Beef, Mutton and Lamb, Chicken, Pork</p> <p>"Vegetables".</p> <p>Potatoes, Tomatoes, Cabbage, String beans, Green peas, Spinach, Celery, Beetroots, Carrots, Mushrooms, Cucumber, Onions, etc.</p> <p>"Fruits"</p> <p>Mandarine, Apple, Banana, Pear, Grapes, Lemon, etc.</p> <p>"Desserts"</p> <p>Fruits pie, Ice cream, French pastries</p> <p>"Cheeses"</p> <p>Gruyere cheese, Process cheese, Efram, Edam, etc.</p> <p>"Drinks"</p> <p>Coffee, Tea, Sanka coffee, Milk</p> <p>"Breads"</p> <p>Hard roll (French roll), White bread, Rye bread, Rice</p>

Cooks who accompanied delegations

With a view to preparing food most agreeable to their particular tastes, some of the delegations brought their own cooks. The numbers of these cooks were as follows:

Italy	1
France	3 (one assigned to Hachioji Detached Village)
Germany	1
India	2
Hungary	1
Poland	1 (Dietician)

These cooks either did the actual cooking or supervised the cooking service in the kitchens of the respective dining halls assigned to their delegations. The dishes prepared by these cooks were served not only to their own team members but also to other members who shared the same dining hall or room.

Night snacks

Night snacks were served to the members of delegations who arrived at the Village later than 9 p.m. Snacks were prepared in advance on the basis of information pertaining to Village registrations and served at the offices of each delegation. From 12th October onward, however, there was no requirement for night snacks. A total of 2,596 snacks was served.

Birthday cakes

Birthday cakes were presented to athletes and officials whose birthdays occurred during their stay at the Village. These cakes were highly appreciated by all such members. A total of 420 athletes and officials received birthday cakes.

Cleaning and sanitation:

Cleaning of the dining halls and the food supply centre was carried out frequently by the dining hall employees to maintain a sanitary environment. Sanitation regulations and sanitation standards for shops were strictly complied with. Full consideration was given to the problem of sanitation and in so doing cooperation was obtained from the Sanitation Inspection Room set up at the Village. As a result of this strict control, no problems of sanitation were encountered.

Food service for Village employees:

Two dining halls were newly constructed for the personnel working at the Village. One dining hall was capable of serving 168 persons and the other, 240 persons at a sitting. In consideration of both quality and price, it was arranged that the dining hall "A" served two or three dishes, while the dining hall "B" offered about 10 different choices of menu.

List of raw materials used

(1 U. S. \$ = 360 Japanese Yen)

Item	Unit	Q'ty	Amount (Yen)
Imported food			
Spice & Condiments			
All spice	1¼ oz	72	8,640
Ginger powder	1⅛ "	72	5,760
Garlic powder	1¼ "	144	17,280
Paprika	1¼ "	720	72,000
Black pepper	8 "	600	192,000
White pepper	1¼ "	2,880	374,400
Chilli powder	1½ "	72	7,200
Curry powder	1 lb	600	204,000
French mustard	6 oz	4,800	384,000
Dry mustard	1 lb	1,200	552,000
Total			1,817,280
Sauce			
Chilli	12 oz	1,200	141,600
Anchovy	6 "	72	9,000
Lea & perrins	10 "	2,400	432,000
A-I	8 "	2,400	288,000
Tabasco	2 "	720	111,600
Tomato catsup	390 g	4,320	410,400
Total			1,392,600
Cheese			
Edam	1 kg	900	405,000
Australian	48/225 g	576	77,760
Esrone	1 kg	600	330,000
Gruyer	"	500	550,000
Q.B.B.	1.65 kg	240	196,800
Total			1,559,560
Vegetable			
Lima beans	# 303	1,920	211,200
Tomato paste	3,170 g	1,200	960,000
Stuffed olive	14½ oz	1,200	576,000
Ripe olive	7½ "	960	172,800
Lemon	140 pcs	2,000	8,000,000
Total			9,920,000
Dry cereals			
Soda craker	450 g	1,800	486,000
Macaroni	450 "	9,600	1,200,000
Spaghetti	450 "	19,200	2,400,000
Oatmeal	40 oz	3,600	1,044,000
Pate de italia	1 lb	48	5,760
Corn starch	1 "	240	16,800
Total			5,152,560
Beverages			
Black tea	1 lb	4,000	2,800,000
Cocoa	1 "	360	162,000
Sanka coffee	5 oz	120	67,000
Total			3,029,200

Item	Unit	Q'ty	Amount
Butter & Bacon			
Fresh butter	1 lb	16,800	3,612,000
Bacon	1 kg	7,000	1,855,000
Total			5,467,000
Fruits			
Pineapple	850 g	960	192,000
Peach	2½ oz	480	64,800
Pear	2½ "	480	100,800
Apricot	2½ "	480	115,200
Fruits cocktail	2½ "	480	91,200
Orange marmalade	1 lb	2,400	336,000
Total			900,000
Fish			
Oil sardine	3½ oz	10,000	600,000
Anchovy fillet	2 "	2,000	140,000
Total			740,000
Oil			
Salad oil	1,731 g	100	4,200,000
Total			4,200,000
Juice			
Grapefruits	1,288 g	4,800	1,104,000
Orange	1,288 "	19,200	6,528,000
Tomato	1,288 "	14,400	2,376,000
Pineapple	1,288 "	4,800	672,000
Grape	645 "	4,800	1,248,000
Total			11,928,000
Domestic foods			
Condiments			
Ajinomoto	1 kg	240	216,000
Ajinomoto soup	5 g	23,800	595,000
Mirin	1.8 l	20	9,180
Sauce	1.8 "	24	2,160
Shoyu	1.8"	300	52,500
Togarashi	1 kg	5	1,500
Wine vinegar	900 ml	10,000	580,000
Table salt	500g	200	14,000
Sugar moist	30 kg	20	80,000
Handy sugar	10 g	360,000	810,000
Miso	10 kg	30	36,000
Cooking salt	25 "	40	33,520
Total			2,429,860
Preserves & Dry fruit			
Strawberry jam	# 5	6,240	655,200
Dry prune	30 lb	4	10,800
Total			666,000

Item	Unit	Q'ty	Amount
Fish			
Crabmeat	C 1	8,640	3,853,440
Tuna fish	T 2	12,960	933,120
Oiled oyster	3 B	15,000	825,000
Nori	10 pcs	300	45,000
Total			5,656,560
Vegetable			
Cream corn	# 303	33,600	1,848,000
Asparagus	# 1	8,400	2,352,000
Green peas	# 10	4,200	1,596,000
Bamboo shoot	# 10	360	180,000
Red pimienta	# 6	2,880	216,000
Dry cepe	1 kg	200	340,000
Dry white beans	10 l	20	40,000
Dry green peas	10 "	40	112,000
Total			6,684,000
Frozen vegetable			
String beans	1 kg	1,200	240,000
Mushroom	1 "	500	215,000
Spinach	1 "	16,000	1,280,000
Total			1,735,000
Dry cereals			
Corn Flakes	170 g	18,000	1,368,000
Flour super camelia	22 kg	120	170,400
Egg noodle	450 g	9,600	998,400
Total			2,536,800
Coffee			
Coffee	25 kg	300	4,725,000
Total			4,725,000
Pickles & Mise			
Pickles	4 T	10	65,000
Beni-shoga	1 "	3	3,000
Hanarakkyo	450 g	72	8,280
Fukujin zuke	1 T	3	4,200
Umeboshi	2 "	3	13,500
Takuwan	2 "	20	44,000
Hakusai zuke	4 "	20	30,000
Kyuri zuke	4 "	20	32,000
Shio zyake	80 g	35,000	1,750,000
Wakame	20 "	5,000	40,000
Aburage	1 pcs	15,000	75,000
Mango chutney	17 oz	48	12,480
Mint	500 g	8	1,600
Estragon	1 kg	1	5,000
Olive oil	1 gal	3	5,625
Mineral water	360 ml	30,000	630,000
Total			2,719,685

Item	Unit	Q'ty	Amount
Spice			
Nutmeg	1 kg	3	3,600
Bayleaf	1 "	3	1,050
Thyme	1 "	3	1,200
Sage	1 "	3	1,050
Caraway seeds	1 "	3	1,800
Oregano	1 "	3	2,100
Saffron	25 g	10	12,500
Barley pearl	900 "	3	600
Total			23,900
Green tea			
Sen-cha	1 kg	800	480,000
Total			480,000
Cooking wine			
White wine	720 ml	200	720,000
Red wine	720 "	100	360,000
Cooking sherry	550 "	70	361,200
Cooking brandy	720 "	100	648,000
Total			2,089,200
Rice			
Rice	1 kg	72,000	7,740,000
Total			7,740,000
Bread			
Slice bread	2 lb	10,000	600,000
Slice bread	3 "	1,000	90,000
Raisin bread	455 g	13,000	546,000
French roll	50 "	190,000	760,000
Butter roll	40 "	225,000	1,080,000
Rye bread	455 "	6,000	252,000
Hot roll	50 "	20,000	86,000
Total			3,414,000
Dessert			
Pie	1 pcs	80,000	1,600,000
Pastry	1 "	80,000	1,600,000
Total			3,200,000
Fruits			
Banana	1 kg	6,000	1,200,000
Apple	100 pcs	3,000	3,600,000
Mandarine	60 "	1,000	1,800,000
Percimmon	60 "	800	1,280,000
Pear	60 "	800	1,040,000
Total			8,920,000
Vegetable			
Onion	20 kg	6,000	10,800,000
Carrot	20 "	4,800	6,720,000
Potato	20 "	12,000	8,400,000
Lettuce	10 "	3,000	5,400,000
Tomato	4 "	20,000	16,000,000

Item	Unit	Q'ty	Amount
Celery	10 kg	1,500	3,000,000
Cucumber	4 "	6,000	4,200,000
Beetroot	1 "	500	50,000
Persely	40 pcs	300	600,000
Cauliflower	8 "	600	420,000
Cabbage	20 kg	1,000	600,000
Leek	1 pcs	1,000	150,000
Red cabbage	10 kg	300	750,000
Norseradish	1 "	1,200	600,000
Turnip	1 pcs	8,000	320,000
Ginger	4 kg	50	40,000
Garlic	4 "	50	35,000
Pimiento	10 "	1,000	2,000,000
Sweet potato	20 "	500	400,000
Radish	20 pcs	500	200,000
Dai-kon	1 "	2,000	60,000
Stone Leek	1 "	1,200	420,000
Eggplant	10 kg	100	80,000
Pumpkin	20 "	50	40,000
Brussle sprout	4 "	100	100,000
Hakusai	20 "	300	135,000
Total			61,520,000
Beef & Pork			
Beef roast	1 kg	11,000	12,100,000
Rump aitchbone	1 "	17,500	14,875,000
Round	1 "	7,200	5,040,000
Spare ribs	1 "	8,400	5,040,000
Hamburg meat	1 "	8,544	5,126,000
Veal	1 "	14,000	10,500,000
Pork	1 "	9,180	6,609,000
Total			59,291,000
Mutton			
Mutton	1 kg	1,530	4,212,000
Total			4,212,000
Chicken			
Chicken	1 kg	43,200	15,120,000
Total			15,120,000
Egg			
Egg	10 kg	^{c/s} 4,000	9,600,000
Total			9,600,000
Frozen fish			
Salmon	1 kg	18,000	6,840,000
Prawn	2.25 "	^{c/s} 6,000	15,000,000
Halibut	100 g	40,000	1,600,000
Kisu	50 "	5,000	60,000
Anago	50 "	5,000	80,000
Haze	50 "	5,000	45,000
Total			23,625,000

Item	Unit	Q'ty	Amount
Meat products			
Boneless ham	1 kg	8,000	6,400,000
Veinna sausage	1 "	2,000	1,100,000
Frankfurt sausage	1 "	2,000	1,000,000
Boiled salami	1 "	1,000	750,000
Bologna sausage	1 "	1,000	500,000
Mortadella	1 "	1,000	700,000
Corn beef	1 "	600	378,000
Corn tongue	1 "	1,300	1,040,000
Kasler	1 "	500	450,000
Total			12,318,000
Dairy products			
Fresh cream	900 cc	24,000	4,320,000
Fresh milk	900 "	80,000	4,400,000
Ice cream (Vanilla)	200 "	200,000	8,000,000
(Chocolate)	80 "	60,000	1,320,000
(Strawberry)	80 "	60,000	1,320,000
Table butter	5 g	600,000	1,440,000
Cooking butter	1 lb	12,000	2,460,000
Total			23,260,000
Grand Total			308,072,205

Dining Room Utensils used

	Numbers		
Table Knives	8,000	Soup Bowls	7,000
Table Forks	8,000	Coffee Cups	10,000
Dessert Spoons	8,000	Polishers	6
Teaspoon	10,000	Service Trays	5,000
Meat Plates	8,000	Toast Boxes	160
Dessert Plates	10,000		

Kitchen utensils used in Olympic Village

Article	No.	Article	No.
Wooden spoon (V. large)	28	Paring knife	259
Wooden spoon (large)	217	Chopper	19
Wooden spoon (medium)	217	Meat baister	32
Wooden spoon (small)	217	Knife steel	38
Bamboo spoon	277	Bone saw	3
Wooden scoop	82	Meat chopper	34
Egg splicer	41	Scaling knife	15
Cheese cutter	15	Roast meat fork	69
Wire strainer	33	Weighing balance (large)	3
Colander	36	Weighing balance (small)	23
Fried food strainer	60	Cooking board (large)	88
Wire fryer	25	Cooking board (medium)	44
Roasting pan (steel)	38	Cooking board (small)	65
Stainless pot-a	170	Aluminum roasting pan	257
b	147	Aluminum grilling pan	257
c	147	Iron pan	142
d	147	Aluminum deep fry pan-a	88
Stainless bowl-a	78	b	89
b	78	c	89
Stainless wire beater	31	d	89
Iron fry pan-a	267	Aluminum butchers tray-a	360
b	137	b	240
c	137	c	190
d	137	Aluminum saute pan-a	68
e	198	b	68
Wire masher sieve	78	c	70
Wire masher sieve (1-go measure)	225	d	70
Wire scoop (A)	82	Saute pan-a	70
Wire scoop (vertical)	78	b	70
Wire scoop (horizontal)	80	c	69
Wire scoop (B)	75	d	69
Wire scoop (5-go measure)	80	Aluminum baking pan	177
Butchers knife	176	Stainless oval-a	205
Butchers sinew knife	83	b	70
Fish knife (Western type)	73	Salad bowl	53
Fish knife (Japanese type)	15	Sauce ladle	138
Roast carving knife	63	Sauce bowl	138
Meat bone cutting knife	58	Wooden trays	53
Game carving knife	58	Stainless trays	207

Other facilities

Various facilities were opened at three different places, viz:—the Shopping Centre, the International Club and the Women's Quarters Centre, where choice articles were sold at low prices. Barber shops, a beauty parlour and a laundry and dry cleaning shop also provided efficient and competent service.

Olympic Theatre: The Olympic Theatre with a seating capacity of 700 presented various programmes daily from 7 p.m. to 9 p.m. Included among such programmes were presentations of Japanese traditional arts with particular emphasis placed on comprehensibility and enjoyability. These included Japanese movies, Japanese dances, folk songs and dances, musical shows, orchestra and band performances. These assortments of programmes provided pleasure and enjoyment to the audience and no doubt added one more enjoyable experience to their village life. The attendance was about 400 daily. Most popular among the Village residents were the musical programmes which always drew capacity audiences.

International Club: The International Club was a place where the members of delegations could relax themselves after their strenuous games. Facilities at the Club included a hall, a Japanese room, a reading room, a lounge, a tea room, a table tennis room and a conference room. Each of the rooms was furnished with a TV set, a radio, a hi-fi set, newspapers and magazines, and some popular musical instruments. Athletes and officials made good use of these facilities and appeared to enjoy the opportunity to meet in this informal manner each evening.

In the spacious hall of the Club, various programmes including tea ceremony, Chinese calligraphy, Japanese painting and band performances, were held each evening from 6 p.m. to 9 p.m.

In addition to these, free vitamin enriched beverages, milk, ice-cream, etc. were available at special stands.

An average of about 1,000 persons used the Club daily. Most popular entertainments were band performances, TV programmes and table-tennis games.

The International Club was not merely a place for relaxation and entertainment, but also proved

Miscellaneous articles and utensils used in Olympic Village

Article	No.	Article	No.
Fire extinguishers	29	Cooking chopsticks	261
Wash cloths	3,000	Knife honing stone (course)	39
Dust pans	28	(fine)	10
Bowls (with stands)	18	(V. fine)	10
Paper baskets	16	Frying basket	75
Mops	25	Steel wool	200
Mops (self wringing)	5	Disinfectant	400
Athletic shoes	340	Filters	8
Rubber leggings	50	Sea-food baskets	300
Scrubbing brushes	121	Cotton waste	200
Cleanser	750	Brooms (long handled)	100
Buckles	68	Working gloves	455
Deck brushes	47	Nail brushes	25
Rubber hose	250	Brooms	100
Toothpicks (round)	1,000	Square brushes	100
Matches	75	Floor scrub brushes	100
Vinyl	6	Cotton thread	100
Cellophane paper	1	Slippers	60
Paraffinpaper—a	20,000	Can openers with stand	13
b	10,000	Corner baskets	200
Torches	13	Shovels	3
Brown paper	30,000	Stationery	—
Detergent	400	Note books	—
Skewers	500	Garbage boxes	50
Tumblers	40,000	Toothpick holders	360
Water glasses	700	Buckets	30
Milk pots	45	Rubbish baskets	20
Toothpicks	240	Detergent liquid	80
Paper napkins	1,000,000	Insect repellent	80
Chopsticks	50,000	Gauze	100
Brooms	140	First aid kits	10
Dust pans	30	Toilet paper—a	10,000
Garbage boxes	85	b	10,000
Sandwich boxes	10,000	Paper towels	50,000
Paper towels	50,000	Paper cases	22
Chair brushes	15	Soap	6,000
Table dusters	3,000	Door mats	30
Paper bags	20,000		

to be a congenial meeting place for promoting international friendship and understanding among the Village residents.

Travel Information Office: A Travel Information Office of the Japan Travel Bureau was set up at the International Club to arrange trips both at home and abroad, handle tickets for these, and sell admission tickets for the delegations.

Sauna bath and steam baths: A sauna bath was constructed for weight adjustment prior to the weight-lifting games. Also, two steam baths, one for men and the other for women, were prepared and provided around-the-clock service. The sauna bath and steam baths, elevated two metres from the floor level, were maintained at temperatures of between 75° to 80°F. The capacity of the sauna bath was enough to take care of ten persons at a time, while

the steam bath for men had a capacity for fifty persons and the one for women for five persons.

The sauna bath and the steam bath for men

Entertainment provided at the Women's Village

Date	Programme
2 Oct.	Japanese "Koto" (Harp) evening (played in concert)
6 "	Flower arrangement
7 "	Folding coloured paper (Origami)
12 "	Impromptu drawing demonstration (shirts and blouses)
14 "	Demonstration of wearing Japanese "Kimono"
17 "	Japanese song evening
19 "	Demonstration of wearing Japanese "Kimono"
20 "	Japanese painting display
21 "	Demonstration of wearing Japanese "Kimono" and Japanese calligraphy
23 "	Impromptu drawing demonstration

List of Various Entertainment provided

Date	Olympic Theatre		Show at International Club
		Programme	
Sept. 24	Cultural Film	"Invitation to Korea" "Two Weeks in Japan"	
25	Cultural Film	"Japanese Gardens" "Judo"	
26	Cultural Film	"Japanese Gymnastics" "Rakutoko" "Hokkaido"	
27	Cultural Film	"Japanese Ancient Cities" "Home Life in Japan"	
28	Cultural Film	"Fuji and Izu" "The Seasonal Changes in Japan" "Education in Japan"	
29	Cultural Film	"Four Seasons of Mt. Fuji"	
30	Cultural Film	"Miyazaki"	
Oct. 1	Feature Film	"Hamlet"	
2	Feature Film	"I am a gull" "Swindler's Tale in World"	
3	Harmonica	Harmonica Concert	
4	Band Concert. Song. Aikido	Golden Pops Concert, Aikido	Band Concert
5	Band Concert. Song	Enjoy with the Music	Tea Ceremony
6	Band Concert. Song	Enjoy with the Music	Tea Ceremony
7	Japanese Old Dance	Japanese Dance	Tea Ceremony
8	Japanese Old Dance	Japanese Dance	Tea Ceremony, Origami Stage Show
9	Japanese Old Dance	Japanese Dance	Band Concert
10	Feature Film	"Sen-Hime"	Band Concert
	Cultural Film	New Zealand movie	
11	Feature Film	"Mother"	Band Concert
	Cultural Film	Rumanian movie	
12	Feature Film	"Phantom Horse"	Band Concert
	Cultural Film	"Ballerina"	
13	Feature Film	"I am two years old"	Tea Ceremony
14	Cultural Film	"Japanese National Parks"	Tea Ceremony
15	Finger Music Song	Finger Music, Italian Opera	Tea Ceremony
16	Folk Song	Evening for Folk Songs	Dressing Service of Japanese Dress
17	Folk Song	Evening for Folk Songs	Band Concert
18	Song, Folk Dance	Soprano Solo, Evening for Folk Dance	Band Concert
19	Cultural Film	"Japanese National Parks"	Japanese Painting
20	Folk Dance, Feature Film	"Sado-Okesa" "Hara-kiri"	Japanese Calligraphy
21	Jazz	Jazz Concert	Band Concert
22	Feature Film	"Ancient City"	Band Concert
23	Dance	Children's Dance	Band Concert, Magic Show
24			
25	Feature Film	"Tsubaki Sanjuro"	Band Concert
26	Feature Film	"Blue mountains"	

First Floor Service Centre

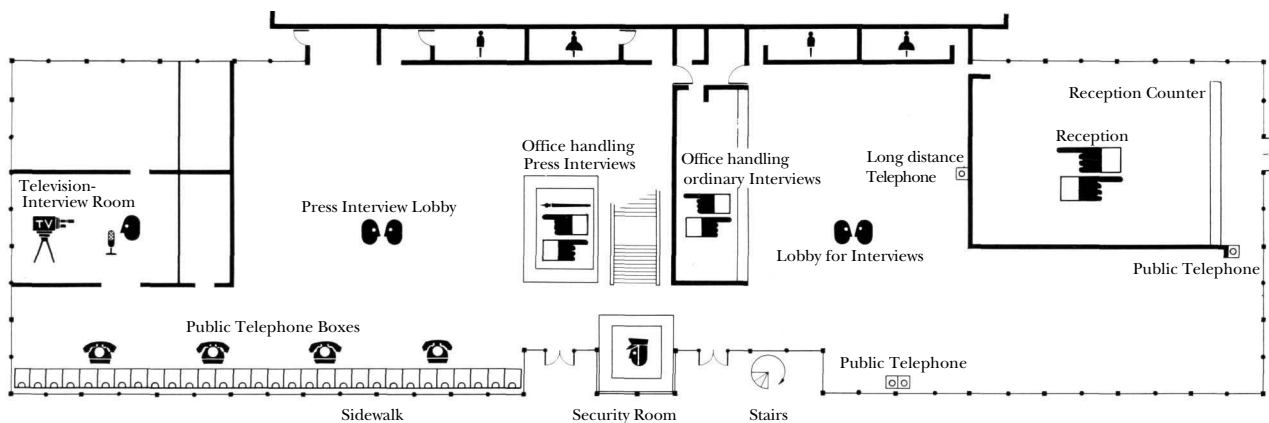

Second floor Service Centre

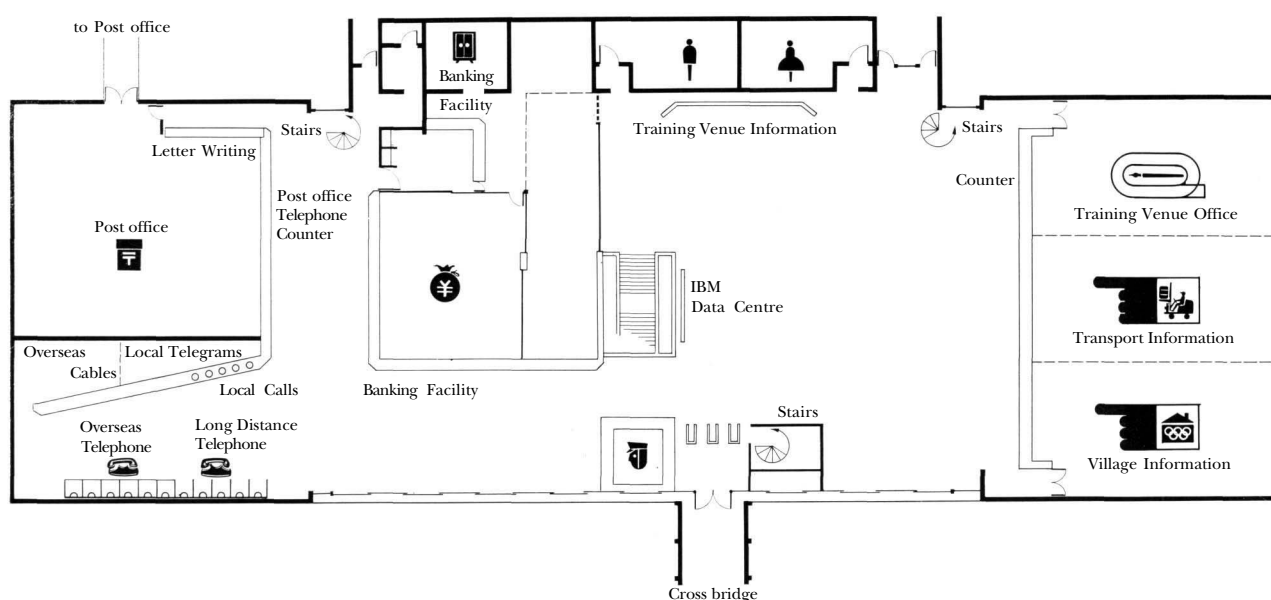

were open with priority on the weight-lifting athletes during the period from 6th October to 15th October when these athletes used them most often. In order to avoid unnecessary confusion, bath tickets were issued to those who desired to use the baths. The women's steam bath was available to women without such restrictions.

In the case of the sauna bath and the men's steam bath, an average of 211 persons daily used these facilities during the period from 25th September to 20th October.

Village training facilities: Applications for use of the track field at the Village (Oda Field), the weight lifting training room and the training pool were required, in principle, to be made to the Training Sites Office on the second floor of the Service Centre. A considerable number of athletes were in practice allowed to make free use of these training facilities.

Bus Terminal: At the plaza in front of the Serv-

ice Centre, a Bus Terminal was set up, from which buses were despatched to various Games sites, training venues and Detached Villages.

Sign Boards, etc.: In order to indicate the locations and directions of the various Village facilities, various signs and marks were put up at conspicuous points throughout the Village.

Clinic: (For details, see chapter on medical service.)

One four-story building was used as a Village Clinic, which was operated by the Medical and Sanitary Section of the Stadium and Ticket Division of the Organizing Committee. The clinical service included the following:—

Internal medicine and surgery (including plastic surgery), X-ray treatment, dental service, ear, eye, nose and throat, physical therapy (massage, plaster application, bath treatment, wave and frequency treatment, pharmacy)

Seven wards were provided, with a total of 19 beds.
 Medical service

Hospitalization, surgical operation, supply of pharmaceutical and medical equipment, treatment, outpatient service, nursing, etc.

Hours

8:50 to 21:00 for internal medicine, surgery, physical therapy, pharmacy, X-ray
 8:00 to 17:00 for ear, eye, nose and throat and dental service

Diagram of Shopping Centre

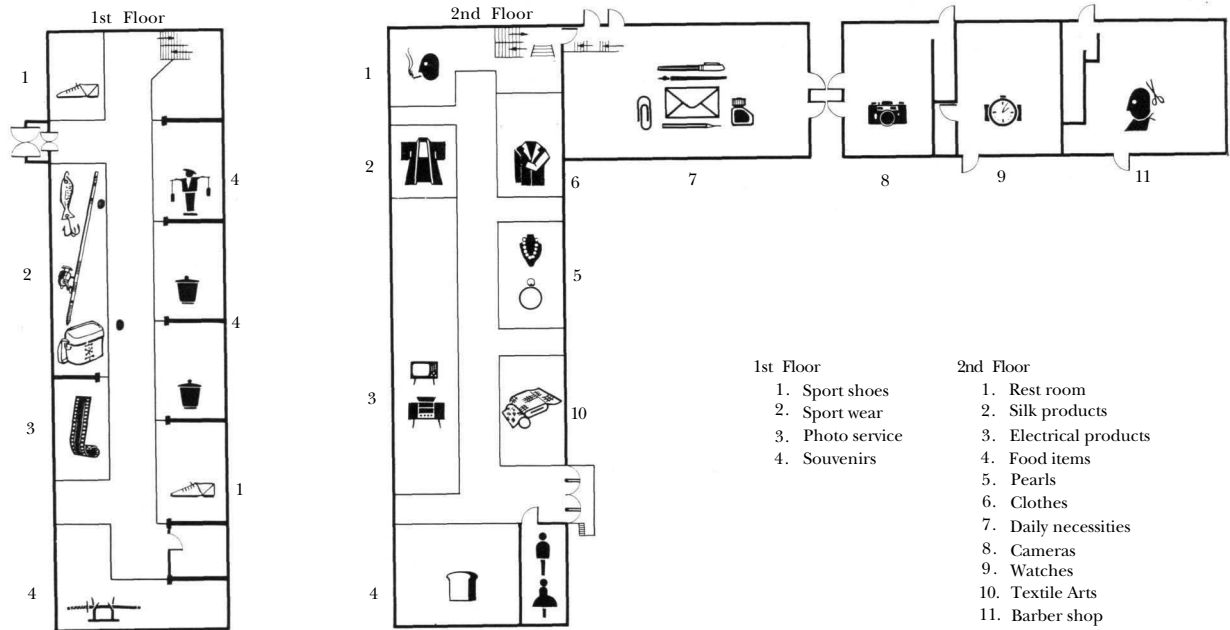

Cleaners

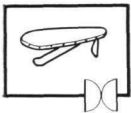

Layout of International Club

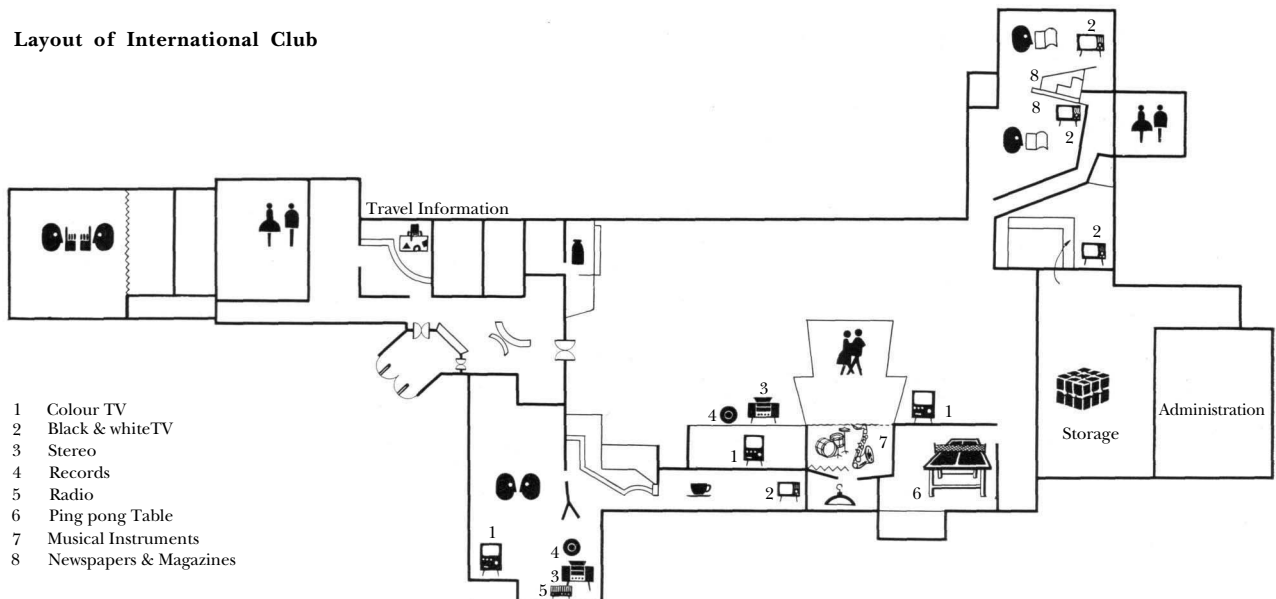

Operation of Detached Villages

Environment and Facilities: Hachioji Detached Village was set up in Hachioji City in the outskirts of Tokyo. The billets were provided at two locations, the one (Ryonan Billets) adjacent to the site of the cycling games and the other (Takao Billets) at the Takao Youth Hostel which had been rented temporarily to accommodate members of each delegation concerned.

These billets were some 4.7 kilometers apart.

The Ryonan Billets consisted of four 2-story light-concrete buildings with 129 rooms and were capable of accommodating 384 persons.

The Takao Billets consisted of one 4-story concrete building with 26 rooms and were capable of accommodating 100 persons.

Lake Sagami Detached Village, about 17 kilometers from Hachioji Detached Village, was set up



The Takao Youth Hostel which served as the Hachioji Detached Village

Hachioji Detached Village

- ① Electronic indication board
- ② Administration office
- ③ Prize receiving room
- ④ Locker room
- ⑤ Telephone room
- ⑥ Clinic
- ⑦ Information office
- ⑧ Interviews room
- ⑨ Dining hall
- ⑩ Kitchen
- ⑪ Tandem room
- ⑫ Massage room
- ⑬ Shower room
- ⑭ Wash room
- ⑮ WC

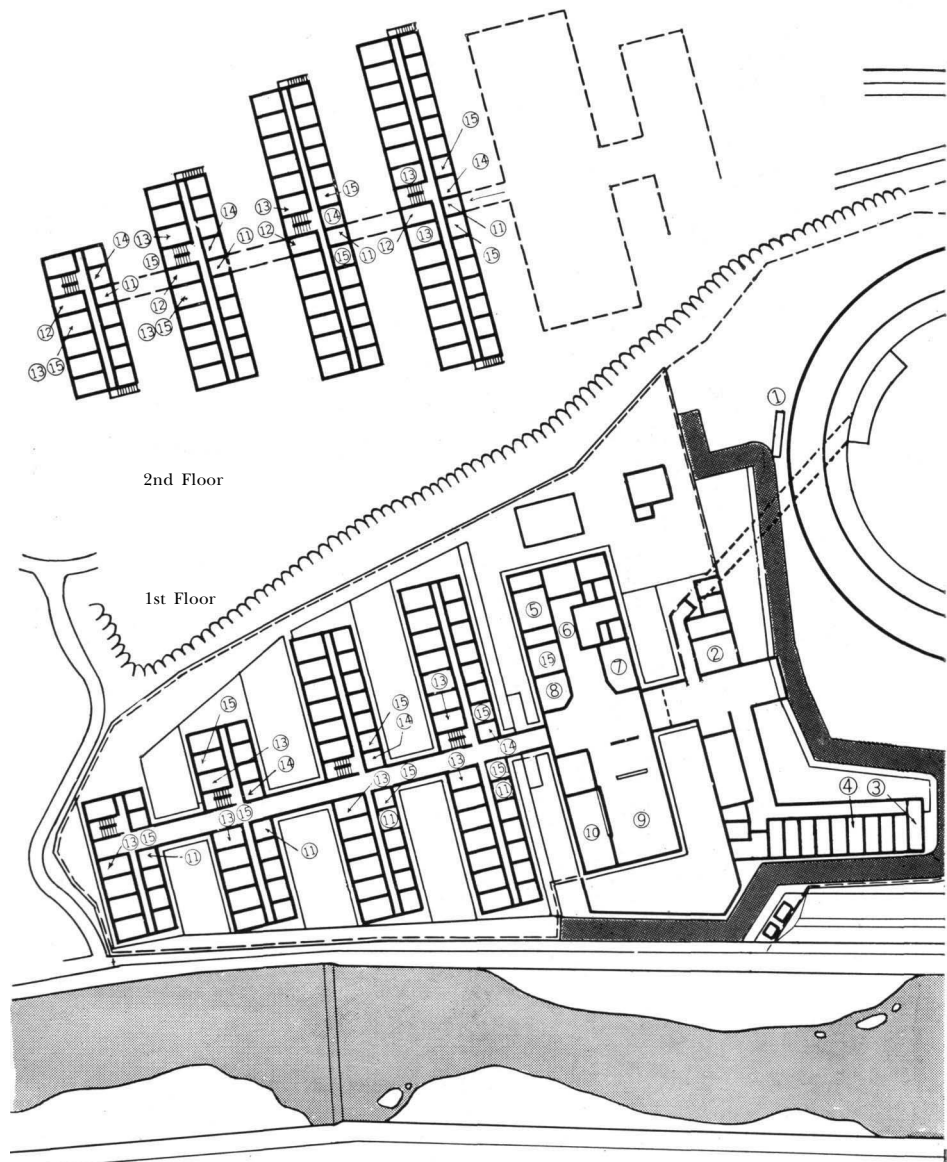



Hachioji velodrome (left) and Hachioji Detached Village (white roofed buildings at right)

near Lake Sagami, Kanagawa Prefecture, where the canoeing events were held. The men's billets consisted of three 2-story light-concrete buildings with 84 rooms which were capable of accommodating 252 persons. The women's billets were provided at Sagami Lake Youth Hostel which was rented for this purpose. This Hostel was a 4-story concrete building with 20 rooms capable of accommodating 64 persons. Certain women's facilities were annexed to this building.

Oiso Detached Village was provided at the Oiso Hotel which was assigned exclusively for the members of the delegations during the events. This Hotel was located adjacent to the Oiso beach in the scenic Shonan area. In addition to this Hotel, an adjacent 5-story concrete building was newly constructed for this occasion. The yacht harbour in Enoshima is some 20 kilometers east of the Hotel. The Hotel consisted of a 5-story concrete building with 83 rooms with a capacity for 305 persons, and a 2-story wooden building with 17 rooms to house 42 persons.

Karuzawa Detached Village was located at Hotel Seizan in Karuzawa, Nagano Prefecture. Karuzawa, 950 metres above sea level, has natural conditions most suitable as a site of equestrian games,

Lake Sagami Detached Village Women's Quarters

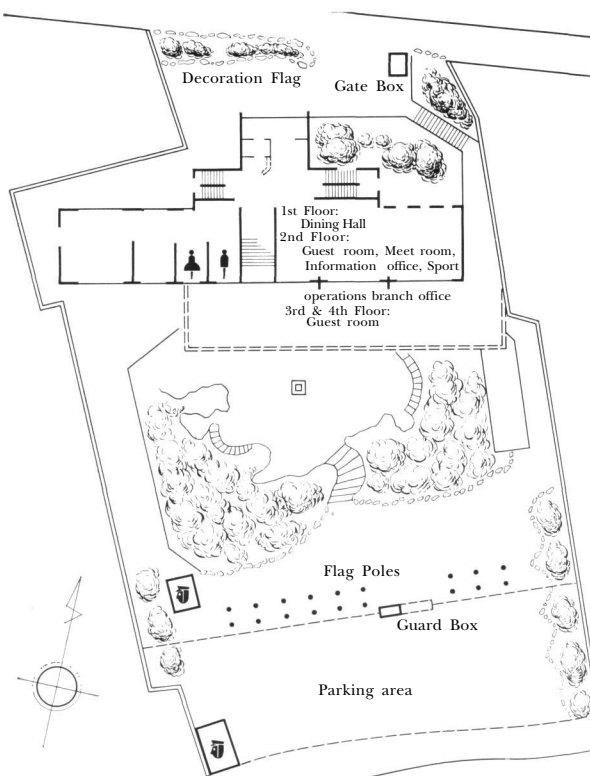

and it is also well known as a summer resort area. The billets consisted of two 2-story wooden buildings with 67 rooms capable of accommodating 138 persons and grooms' quarters with a capacity for 64 persons. The grooms' quarters were provided by

remodelling the hall of the Hotel.

Stables for 108 horses, and stables for horses while undergoing quarantine inspection, and stables for horses which needed to be isolated were provided. Horse treatment and shoeing facilities were also

Floor Plan of Men's Quarters of Lake Sagami Detached Village

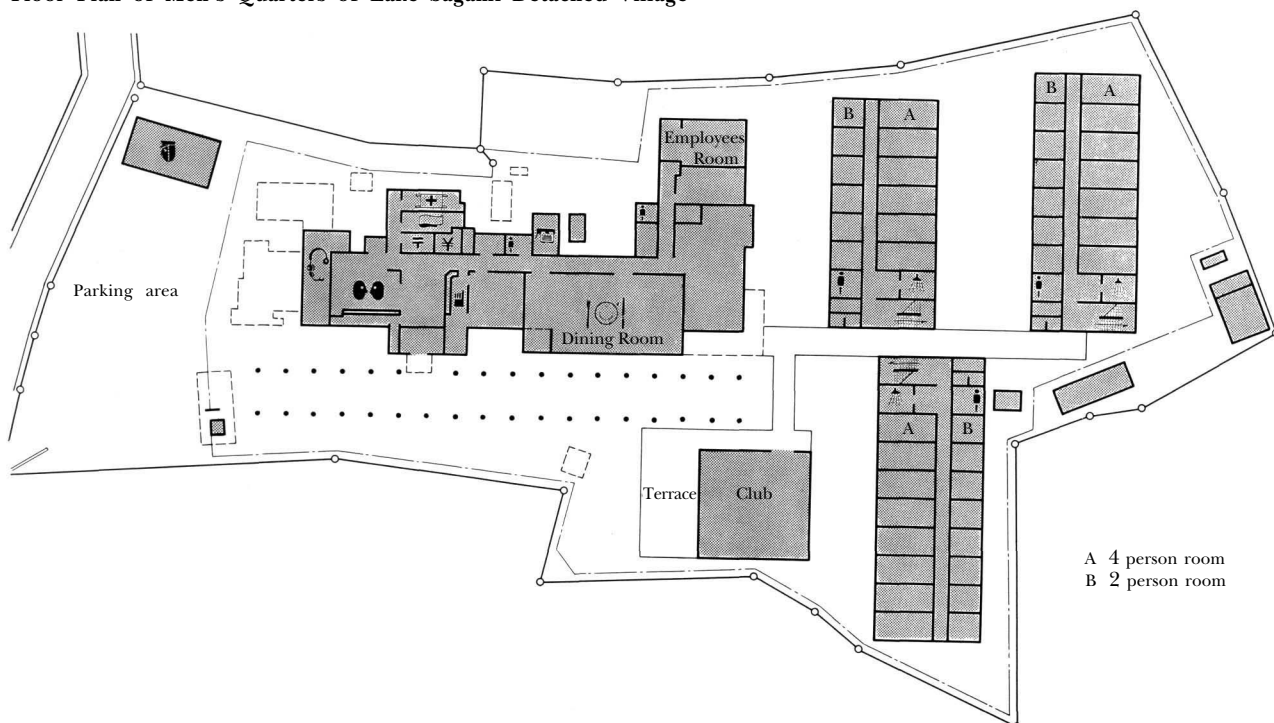

A view of the Women's Quarters at Lake Sagami Detached Village

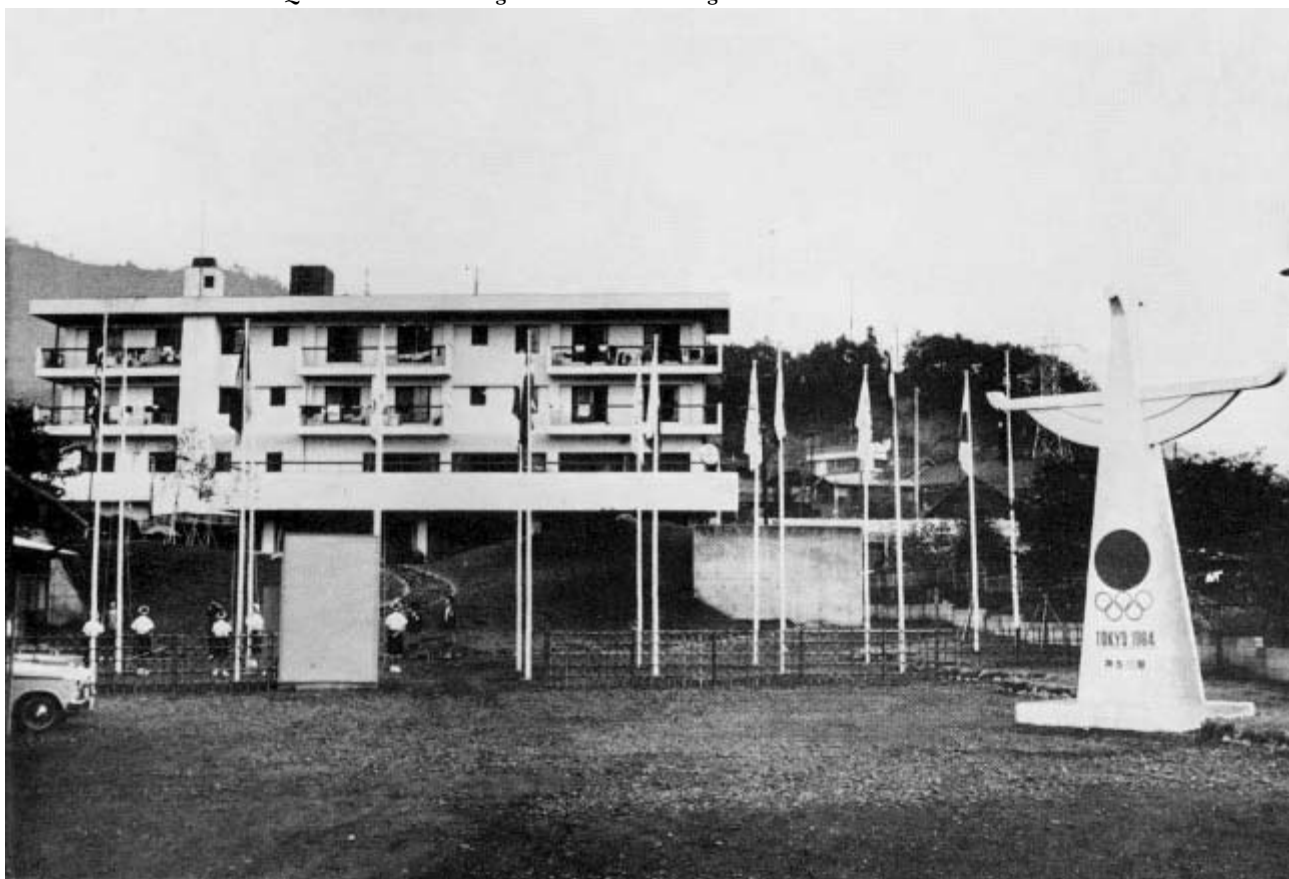

Oiso Detached Village

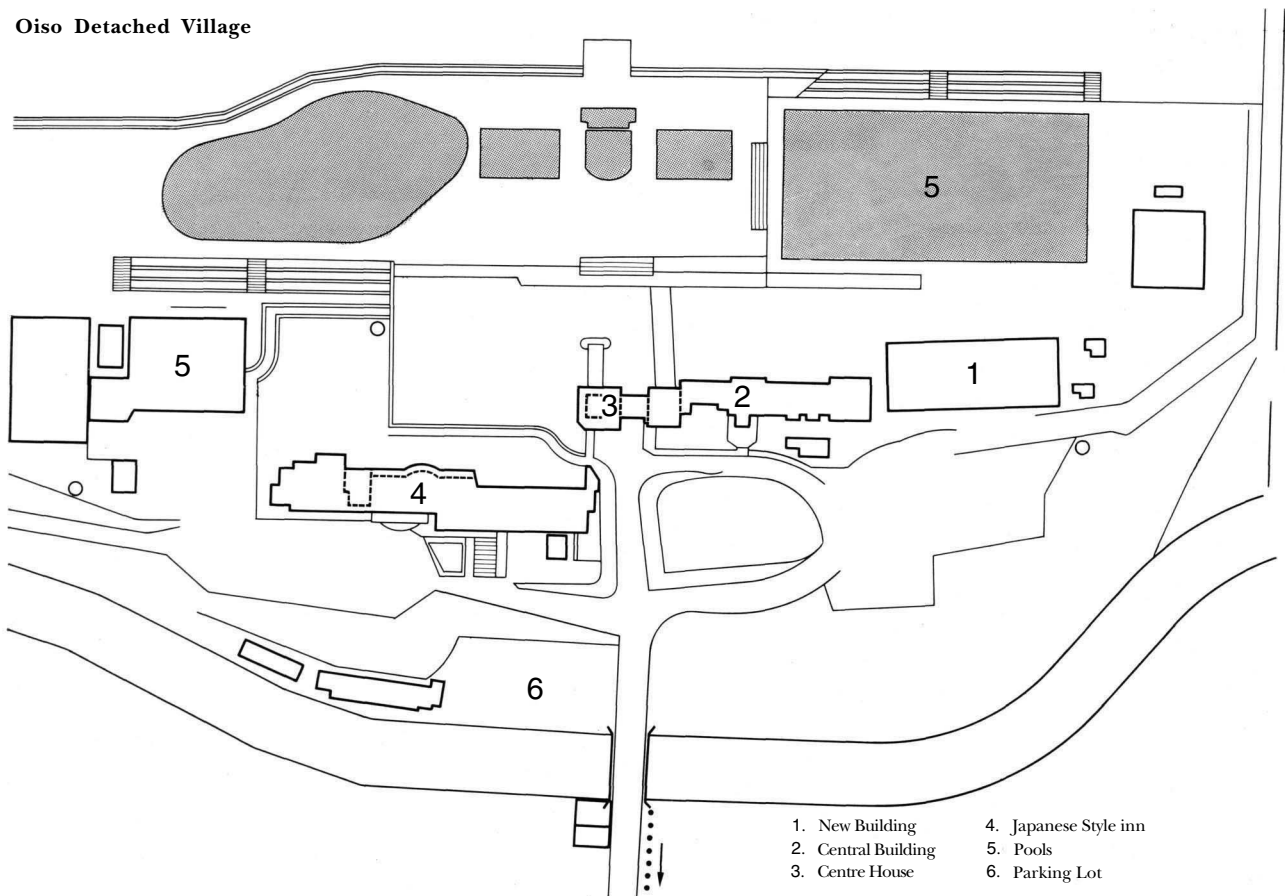

provided. 65 horses were housed in these stables, which were operated much in the same way as was the Equestrian Park Annex.

ties of registration office, interview room, information office, post office, bank, shops, barber shop, lounge and dining hall, were constructed.

At each of the Detached Villages, the usual facili-

Karuzawa Detached Village

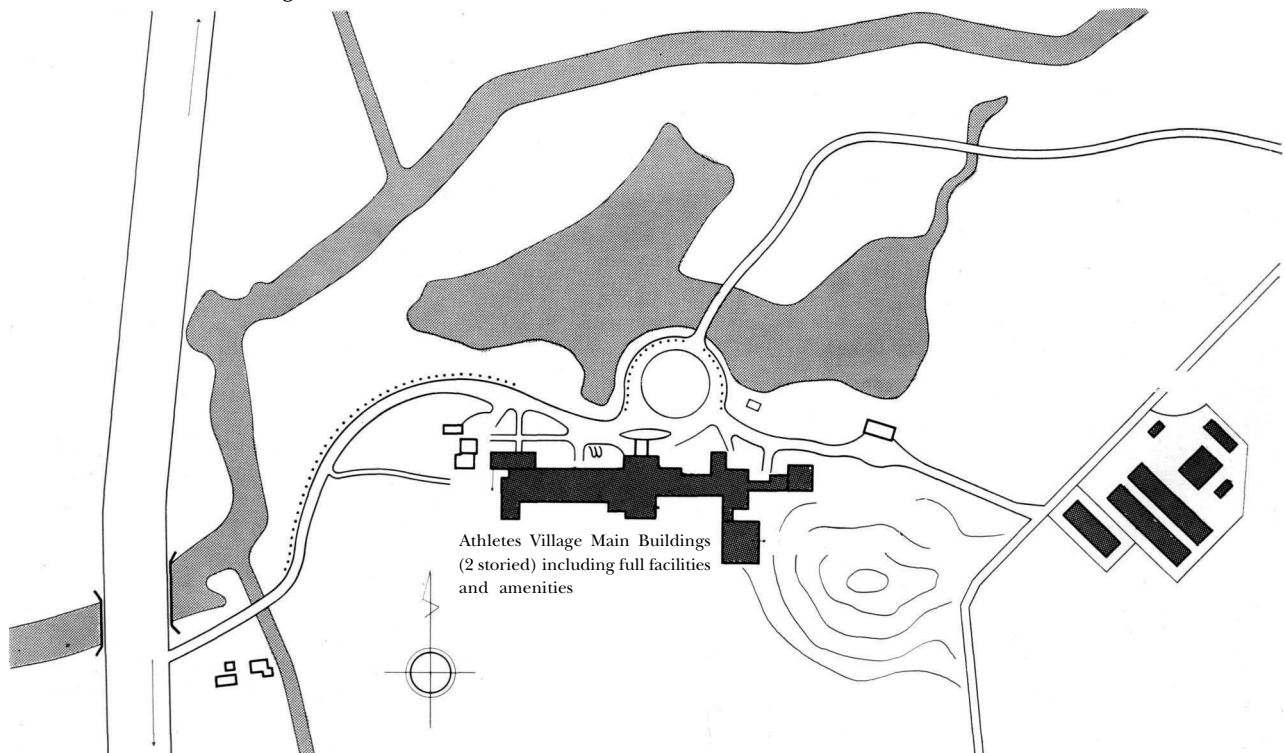



Japanese Tea is made while athletes relax in front of their quarters at Lake Sagami

Transportation to and from the Yoyogi Olympic Village: Regular bus services were scheduled between the Main Olympic Village and each of the four Detached Villages. The time required for transportation and distances involved are shown in the Figure on the following page.

Operation policy and organization of Detached Villages The Detached Villages were operated in much the same way as was the Yoyogi Olympic Village. Particular attention was paid to maintaining equal food and other services at all of the Detached Villages. The Detached Village Section

Travelling time between Yoyogi Main Village and the Detached Villages

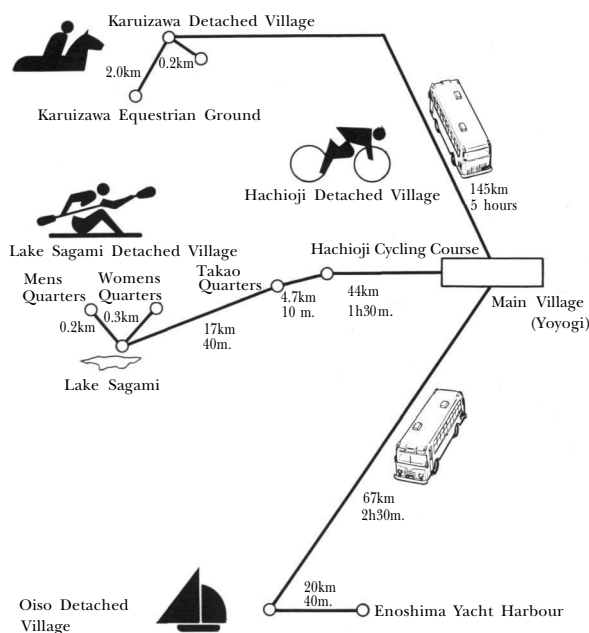

was created within the Olympic Village Administration to effectively handle these Detached Villages. Responsible persons were appointed to take charge of each of the Detached Villages and of the planning of its organization.

As was the case with the Olympic Village at Yoyogi, some of the services were entrusted to other Divisions of the Organizing Committee, government agencies and private organizations. Each of the sections of these Villages maintained close contact with its counterpart at the main Village.

The number of personnel assigned to each of the Detached Villages was 330 at Hachioji, 399 at Oiso, 279 at Lake Sagami and 304 at Karuizawa.

Operation of the Detached Villages The Detached Villages were operated in general in a way similar to the Main Village.

Procedures for registering and clearing: The teams entered and left Oiso Detached Village without staying at the Yoyogi Village. In the case of other Detached Villages, however, the delegations concerned stayed at Yoyogi overnight before they were registered at their respective Detached Villages. Any baggage and equipment that could not be loaded on the buses were transported by truck.

General resident status at the Detached Villages: The cumulative total number of residents at Hachioji Village was 9,537, and the highest number of residents recorded in a day was 404, representing

38 countries. At Oiso Village, the cumulative total number was 7,245 and the highest daily record stood at 286, representing 38 countries. At Lake Sagami Village, a cumulative total of 4,270 or 213 persons a day, representing 21 countries, were registered. The number of residents at Karuizawa Detached Village stood at a cumulative total of 2,434 or 117 a day, representing 12 countries.

In addition to the regular residents, some athletes and officials of the Main Village entered the Detached Villages temporarily during the games. Especially at Karuizawa, the number of such transient residents reached as many as 50, inasmuch as the equestrian sports were held both in Karuizawa and Tokyo. By reason of these additional residents, the billets at Karuizawa Detached Village were somewhat crowded.

Billet assignment: In principle, billets were assigned on a "first come first served" basis. Although women's billets were provided at Sagami Bay Village where some women competitors participated in the canoeing events, no women's billets as such were provided at Oiso and Karuizawa because it was thought that few women competitors would take part in the yachting and equestrian sports. When necessary, women's billets were assigned from among the men's billets already assigned to the delegations concerned. Billets for grooms at Karuizawa Village were assigned on the basis of one room for every 1-2 teams, as was the case with the Equestrian Park Annex.

Catering: Catering service was entrusted to contractors (to the Hotels concerned at Oiso and Karuizawa and to Fuji Ice Co. at Hachioji and Sagami Bay).

Each of the contractors prepared menus and procured food in coordination with the Japan Hotel Association.

One dining hall was set up at Oiso and Karuizawa, and two dining halls were provided at Hachioji and at Lake Sagami inasmuch as the billets for each of this two Villages were located at two different sites.

Bank, Post Office, and International Telegraph and Telephone:

At each of the Detached Villages, banking, postal and telegraph and telephone services were provided.

Main events at the Detached Villages: An Opening Ceremony and Registration Ceremonies were held at each of the Detached Villages in much the same way as at the Main Village.

Use of Yoyogi Village facilities: Residents at the Detached Villages were permitted to freely utilize the various facilities at the Main Olympic Village at Yoyogi.

The popular International Club





Men's Quarters and bedrooms



Women's Quarters & beds





Women's Beauty Parlor



Bath house located at the center of the Men's Quarters

Barber Shop





Looking down at the Fuji Dining Hall (above) and its Kitchen (right)



Athletes Service Centre





The Olympic Theatre in the Main Village with a scene from one of the Japanese evenings presented



The busy Press Interview rooms





Entrance to the Women's Quarters where women check officials were on duty

A wedding performed by traditional Japanese Shinto Rites took place inside the Village between two athlete participants to the Tokyo Games





Morning Devotions are held outside the Italian Quarters

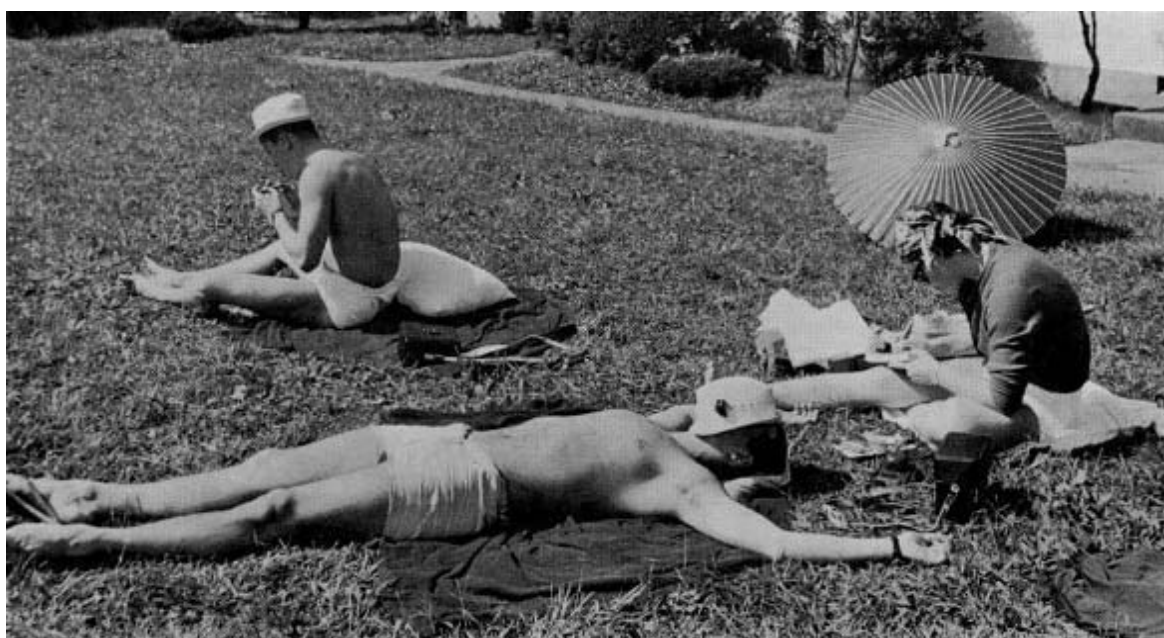

The lawn was a popular place for sunbathers



Some of the ladies tried on Japanese Kimono



The Team from Sweden preparing to depart



Women Athletes from USA bid "Sayonara"



One by one the teams left the Village and by 5th November only the Japanese workmen and administrative staff were left for the final Village Closing Ceremony



The dining halls in the village were a meeting place for all the athletes (at left are the meal coupons)

Brilliant displays of chrysanthemum in the village took the attention of all passers by





Bicycles were an ideal way of getting round inside the village

Even waiting for a bus in the rain was fun





Shopping or even window-shopping was also interesting

Cameras proved the most sought after item for purchase





"Not as easy as it looks"—the Japanese melodious "Koto"



Music and dancing was a good "ice-breaker" even between strangers





The 'service centre' at the main entrance performed a most valuable function



The detached village at Karuizawa held its own opening ceremony



At the Lake Sagami detached village

A view of the Oiso detached village from the air





The lobby of the Hachioji detached village





This was a typical scene around the Shibuya gate to the main village
From the air the main entrance to the village looked like this



The village of friends-

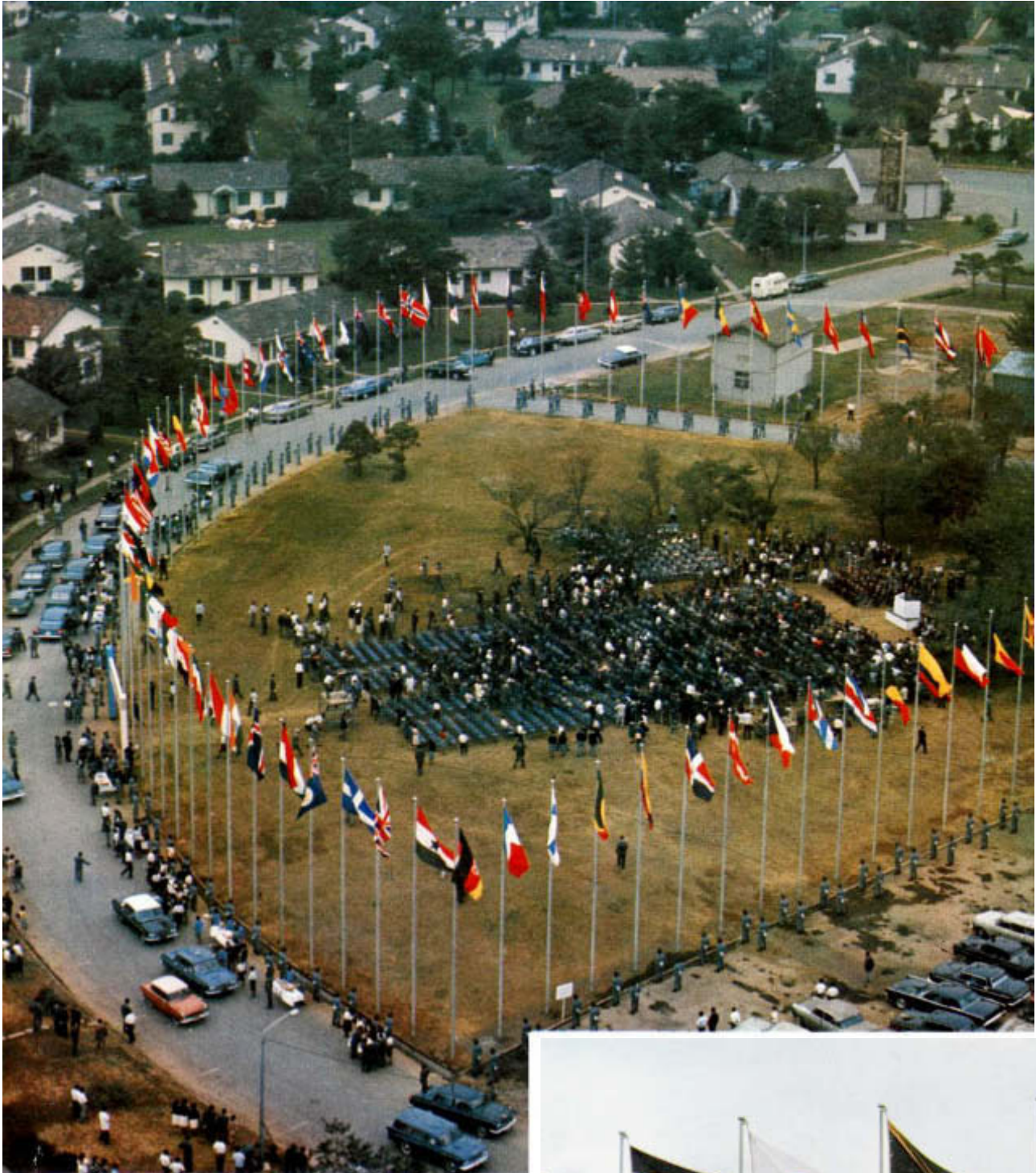

The Olympic Village was opened from the 15th September (upper), (lower) at the opening ceremony at the central field in the Olympic Village







An aerial view of the Main Olympic Village at Yoyogi



New arrivals get directions from the Village plan

Table showing numbers of male personnel billeted according to blocks

A		B		C		D	
Name of Team	No. of Persons	Name of Team	No. of Persons	Name of Team	No. of Persons	Name of Team	No. of Persons
Germany	329	USSR	349	UAR	99	Spain	75
USA	317	Hungary	192	Uganda	18	Argentina	121
Congo	3	Rumania	144	Ghana	41	Brazil	74
Colombia	20	Mongolia	22	Tanganyika	6	Mexico	108
				North Rhodesia	14	Chile	21
				Rhodesia	28	Panama	13
				Kenya	47	Peru	39
				Nigeria	22	Venezuela	19
				Liberia	6	Portugal	22
				Czechoslovakia	113	Costa Rica	2
				Poland	133	Cuba	42
				Bulgaria	76	Uruguay	24
				Germany	29	Dominicax	2
				Austria	53	Bolivia	1
				Denmark	40	Israel	13
				Liechtenstein	3	Cameroons	1
				Afghanistan	11	Ivory Coast	12
						Mali	4
						Morocco	36
						Senegal	16
						Tunisia	17
Total	669		707		739		662

E		F		G	
Name of Team	No. of Persons	Name of Team	No. of Persons	Name of Team	No. of Persons
Great Britain	171	Finland	106	Japan	307
India	67	Iceland	4	New Zealand	65
Italy	178	Ireland	23	Australia	205
France	134	Norway	23	Malaysia	77
Switzerland	74	Sweden	83	Chad	3
Greece	20	Turkey	31	Niger	3
Lebanon	7	Nepal	10	Algeria	1
Viet Nam	21	Pakistan	55		
Belgium	60	Philippines	51		
Luxemburg	13	Jamaica	17		
Monaco	2	Ceylon	7		
Madagascar	4	Thai	53		
Cambodia	10	Taiwan	50		
		Korea	184		
		Yugoslavia	88		
		Burma	16		
		Bahama	4		
		British Guiana	3		
		Iran	72		
		Iraq	27		
		Netherlands	110		
		Ethiopia	11		
		Neth. Antilles	7		
		Canada	100		
		Puerto Rico	42		
		Trinidad & Tobago	12		
		Hong Kong	37		
Total	761		1,226		661



- 1 Service Centre
 - 2 Village Headquarters
 - 3 Village Headquarters Annex
 - 4 Women's Village Centre
 - 5 Fuji Dining Hall
 - 6 Sakura Dining Hall
 - 7 International Club
 - 8 Olympic Theatre
 - 9 Clinic
 - 10 Shopping Centre
 - 11 Bath House
 - 12 Sauna
 - 13 Bath House (women's)
 - 14 Luggage Handling Office
 - 15 Oda Field
 - 16 Women's Village Plaza
 - 17 Village Pool
 - 18 Fire Station
 - 19 Bus Terminal
 - 20 Interview Room
 - 21 Yoyogi Parking Area
 - 22 Car Parking
 - 23 Gasoline Stand
 - 24 Yoyogi Slopes
 - 25 Tokyo Plaza
 - 26 National Gymnasium
 - 27 Shibuya Public Hall
 - 28 Telephone Exchange
 - 29 Storage
 - 30 Food Storage
 - 31 Weightlifting Training Area
 - 32 Weighing-in Room
 - 33 Staff Dormitories
- ① Main Gate
 - ② Sangubashi Gate
 - ③ Harajuku Gate
 - ④ Shibuya Gate
 - ⑤ Traffic Gate
 - ⑥ Entrance to Headquarters
 - ⑦ Women's Village Dining Hall
 - ⑧ Main Gate to Women's Village
 - ⑨ Traffic Gate to Women's Village

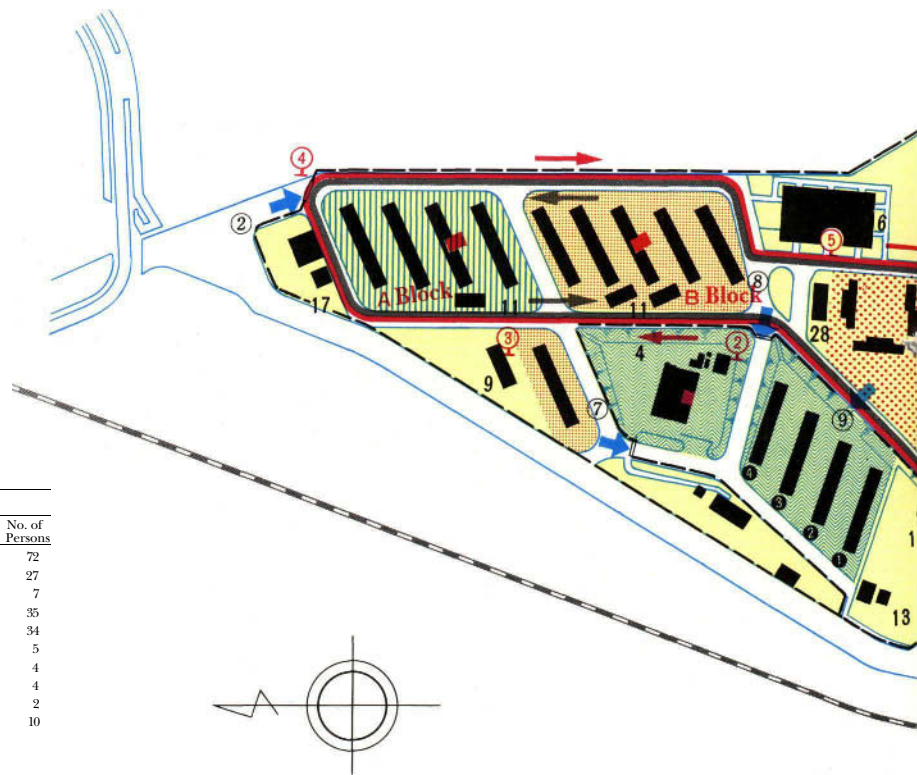

Layout Plan of the Main Olympic Village at Yoyogi



Women's village personnel listing

①		②		③		④	
Name of Team	No. of Persons	Name of Team	No. of Persons	Name of Team	No. of Persons	Name of Team	No. of Persons
USA	91	Colombia	3	Germany	80	USSR	72
Ireland	1	Korea	12	Denmark	5	Poland	27
Iran	6	North Rhodesia	1	Austria	11	Bulgaria	7
Israel	2	Cuba	3	Netherlands	24	Hungary	35
Korea	15	Great Britain	49	Luxemburg	2	Rumania	34
Thai	8	Finland	7	Switzerland	1	Mongolia	5
Taiwan	5	Philippines	10	Australia	43	Ghana	4
Japan	62	Brazil	1	France	22	Rhodesia	4
New Zealand	10	Sweden	18	Nigeria	3	Uganda	2
Jamaica	6	Portugal	3	Italy	13	Czechoslovakia	10
Malaysia	6	Canada	21				
Yugoslavia	3	Venezuela	1				
Peru	1	Panama	4				
		Spain	3				
		Mexico	6				
		Argentina	8				
		India	1				
		Hong Kong	1				
		Belgium	1				
		Norway	2				
		Iceland	1				
		Puerto Rico	3				
Total	216	Total	159	Total	204	Total	200

 Right Shuttle Bus Route
 Left Shuttle Bus Route

 Traffic Gate
 Area Administrative Office

Bus Operated	7:30 am—8 pm
Bus Circuit	Approximately 15 minutes
Bus Route	15 Sept.—30 Sept. Anticlockwise Route Stopping at 15 points 1 Oct.—5 Nov. Both Clockwise & Anticlockwise Stopping at 30 points
Number of Buses	15 Sept.—24 Sept.—(3) 25 Sept.—30 Sept.—(4) 1 Oct.—31. Oct.—(6) 1 Nov.—5 Nov.—(4)



- Bus Stops**
- ① Main Entrance Gate
 - ② Women's Village Entrance Gate
 - ③ Clinic
 - ④ Sangubashi Entrance
 - ⑤ Sakura Dining Hall
 - ⑥ E Block Administrative office
 - ⑦ F Block Administrative office
 - ⑧ Harajuku Entrance
 - ⑨ Gasoline Stand
 - ⑩ Shibuya Entrance
 - ⑪ Japanese Team Office
 - ⑫ Oda Field
 - ⑬ Fuji Dining Hall
 - ⑭ Olympic Theatre
 - ⑮ Tokyo Plaza



Welcome ceremonies for the newly arrived delegations were held almost daily at the beginning (upper)

(lower) 'The Village News' newspaper published in English and French at frequent intervals during the time the village was open

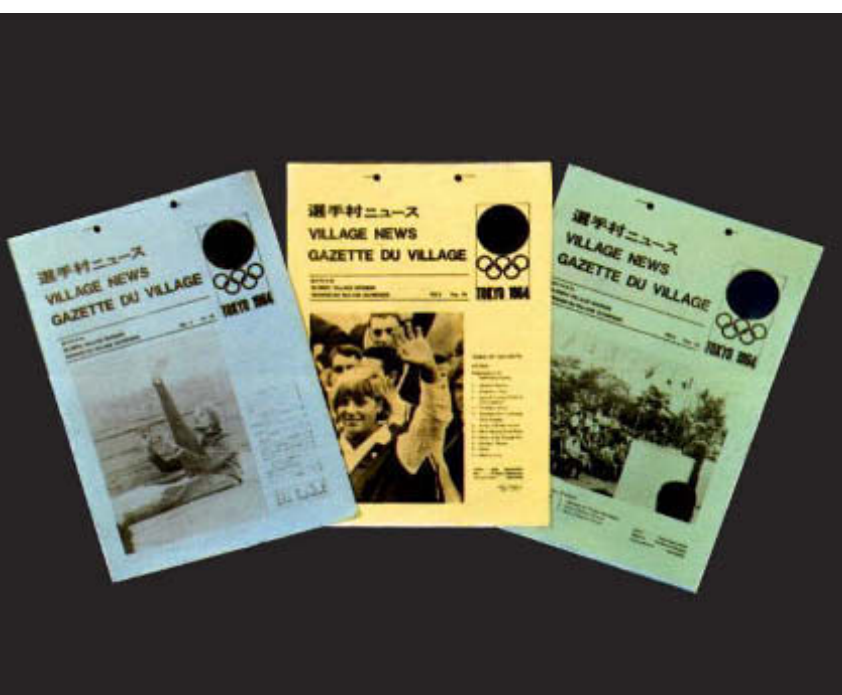

On the central recreation ground known as 'Oda Field' could always be seen busy and happy scenes of athletes training, playing or just enjoying meeting each other





Wrestlers found the lawns were good places for "warming-up" for their events

The swimming pool inside the village was popular for fun and for conditioning

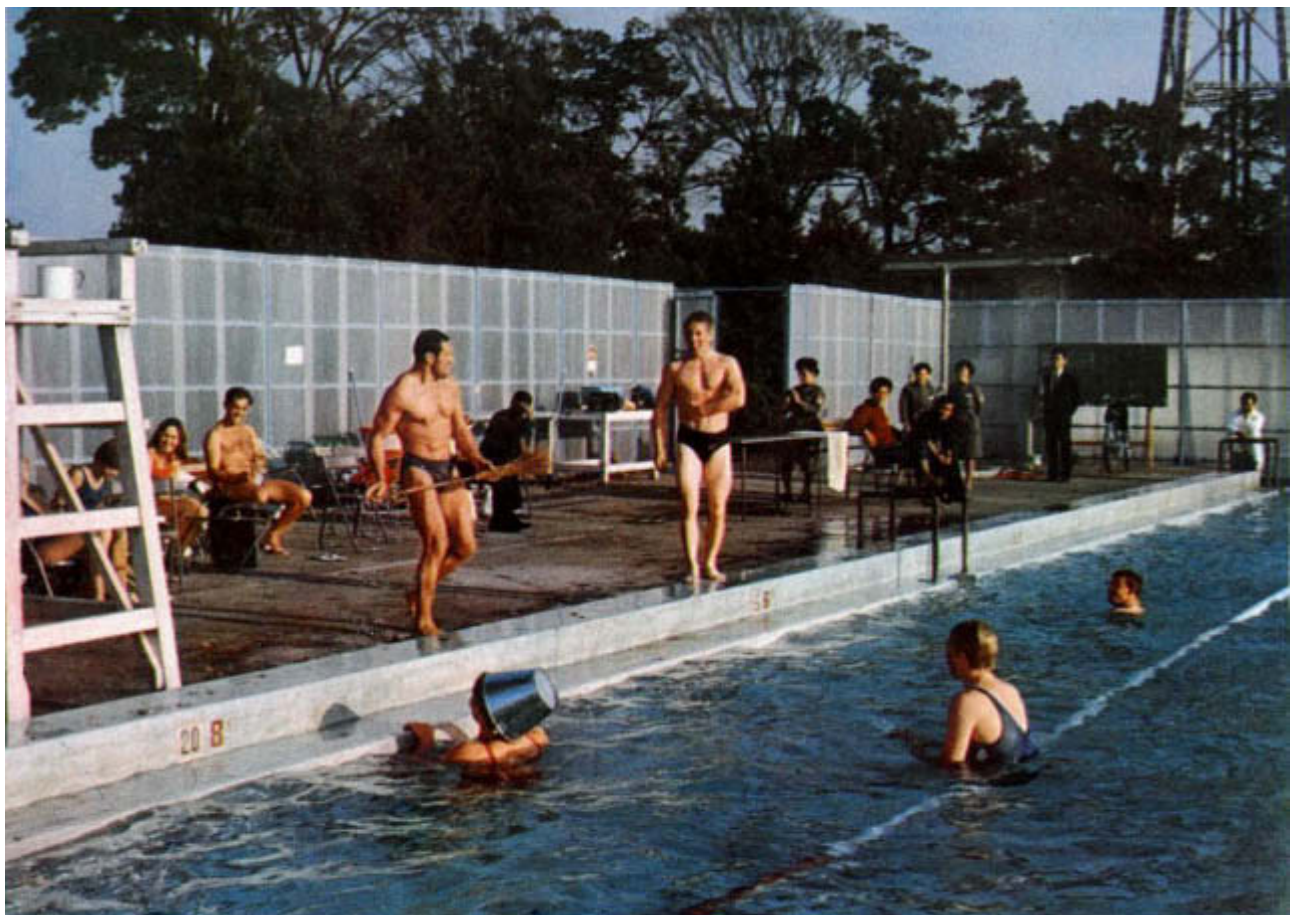

PUBLICITY

Significant credit for the public relations activities for the Tokyo Olympic Games should be given to the press, radio, television and other mass communication media. The many special Olympic supplements or Olympic programmes which this media featured, resulted in a wide dissemination of information and a general focussing of interest on this great athletic festival. That the Organizing Committee did not in fact sponsor any television programmes until the final days of preparations cannot only, then, be attributed to considerations of a financial nature, but to some degree was directly due to the voluntary role of the mass communication media who assumed much of this responsibility.

The publicity activities actually carried out by the Organizing Committee, from its inception in 1959, were more particularly confined to the publication field, or specifically, to the posters and explanatory pamphlets both in Japanese and foreign languages, and to the periodical publication of bulletins. Slides and film shorts were also prepared and used to advantage where considered necessary. Other activities included exhibits and lectures carefully arranged to achieve as wide an audience as possible, by taking advantage of the occasions of national sports festivals and international trade fairs.

Publication and Distribution of Official Posters

In February 1961, the first official poster was published—the first of a series of four. These four official posters which were to be seen widely throughout the world were:—No. 1—"The Rising Sun and the Olympic Emblem"; No. 2—"The Start of Sprinters Dash"; No. 3—"A Butterfly-Swimmer" and No. 4—"An Olympic Torch Runner." All four were designed by Mr. Yusaku Kamekura, and for No.'s 2 onwards, he had the cooperation of Messrs. Osamu Hayasaki and Jo Murakoshi as staff photographers.

All these posters were in multi-colored photogravure, a distinct technical accomplishment for Japan's printing industry, the quality of printing was the subject of favourable comments both at home and abroad, and the posters themselves received a number of prizes for their excellence, including the Milan Poster Design Award.

The first poster with its striking design from Japan's National flag, to some extent served to

renew the appreciation of the Rising Sun's dynamic simplicity. Some 100,000 copies of this poster were printed and distributed before the Games.

The second official poster was modeled with the cooperation both of athletes of the American Forces stationed at the Tachikawa Air Base in Japan and of Japanese amateur athletes. The photo was taken on one wintry night in February, 1962, at the National Stadium. Ninety thousand copies of this poster were distributed.

The first photos for the third official poster were taken at the Tokyo Metropolitan Indoor Swimming Pool in February, 1962, with swimmer Furukawa and other Japanese free-style, backstroke and butterfly swimmers, and also Mr. W. Yorzyk (USA) who was 1956 Butterfly Gold Medalist at Melbourne, acting as models. None of these photos, however, were accepted, and later a butterfly trio of Waseda University, Izutsu, Yoshimuta and Iwamoto were called in to cooperate, and a picture modeled by Koji Iwamoto was selected for the poster. Some 70,000 of these posters had been distributed by the opening of the Games.

The final official poster was made at the beginning of 1964 and 50,000 copies were distributed. The Olympic Torch Runner selected to adorn this last of the poster series was athlete Tanaka of the Juntendo University track and field team.

In Japan, these posters were distributed to all local government offices, Amateur Sports Associations, public buildings, news media, airlines, prominent trading companies, tourist agencies, business firms and banks, etc. The overseas distribution included the International Olympic Committee, National Olympic Committees, International Sports Federations, and Japan's Embassies and Legations in the various countries. These posters were responsible for accentuating the Olympic mood which prevailed both at home and abroad.

Printed Matters and Periodicals

The Organizing Committee Official Bulletins (Japanese Edition) The first Japanese edition bulletin was issued in March 1960, and altogether thirty of these Japanese edition bulletins were published, the last one in December 1964, after the Tokyo Games were completed. Each issue of 20,000 copies was distributed to interested persons in the various Prefectural offices, Tokyo Metropolitan Government, Amateur Sports Associations, public libraries,

mass communication media, banks and business companies, the National Diet and Central Government offices.

In the earlier issues of the bulletins, emphasis was placed on informative articles on the history and development of the ancient as well as the modern Olympics. Later, as the schedule of events for the Tokyo Olympics, as well as the sites and facilities, became more definitely planned, the pages of these bulletins were treated in a more analytical manner and contained reminiscences of medalists of former Olympics and outlines of each of the twenty events to be included.

From the beginning of 1964, the Olympic Year, the articles gave greater reference as to how the various organizations in charge of strengthening the Japanese entries were progressing with that task, forecasts of Japanese athletes' success, as well as general forecasts of the scheduled events. Bulletin No. 29 published in September, just before the opening of the Tokyo Games, contained the coordinated programme of all events, full lists of the participating nations, guide maps for localities, and venues where the events would be held and a number of photos of completed constructions. It was edited to be a manual for the Tokyo Olympic Games.

The final issue—No. 30—included photos of the opening and closing ceremonies as well as of the Games' highlights. It also contained summarized results of the Tokyo Olympic Games and a complete list of the medalists.

Foreign Language Bulletin English and French formed the language of the foreign language bulletins for overseas publicity. As the "Official Bulletin", its first issue was published in May, 1961, and by the opening of the Tokyo Games, 21 issues of 20,000 had been printed and distributed.

The object of the foreign language bulletins was to inform the various foreign countries on how Tokyo was preparing for the Olympics. An attempt was made to introduce the host city of Tokyo—its plans and projects on the various venues to be constructed or improved for the scheduled events. Articles were included to acquaint overseas visitors with the method of obtaining admission tickets, with the organized preparedness to receive foreign visitors, how foreign teams should prepare their entries, and informative details of the Olympic Village in Tokyo. Great care was exercised in editing this bulletin to make it as useful and informative as possible for visitors from abroad. Up until the end of 1963, it was published every other month, but from April of the Olympic Year, it was published monthly as more detail was required to be disseminated.

The foreign language bulletin was distributed by both air and sea mail to the IOC, NOC's, IF's, news media, press services, and tourist agencies. As the opening of the Tokyo Games drew near, the supply to meet the demand from sources within Japan was partly checked; and from the 17th to the 21st issue, part of the issue was withheld in reserve to be

Pamphlets and Publicity Material issued

Name	Issued	Type and pages	No. issued	Contents and/or usage
Olympic Day draws near	8 June 1960	A5. 20 pages	20,000	Olympic Day
Report to the 57th IOC General Session	11 Aug. 1960	B5. 80 pages	1,000	IOC General Session
The Glorious Tokyo Olympics	14 Dec. 1960	B6. 130 pages	1,000	Kanto area schools
Leaflet No. 1	6 Mar. 1960	10x20 2 pages	2,000	For general distribution
"Tokyo Invites ..."	10 Apr. 1961	4·6. 24 pages	10,000	Rotary Int'l Congress
Olympic Facts & Figures for teachers' use	10 Aug. 1961	B4. 36 pages	1,000	For school teachers
Olympic background	12 Sept. 1961	B5. 34 pages	20,000	Akita National Athletic Meet
Picture postcards	8 Mar. 1961	11.25X15.6	3,000	Osaka Int'l Trade Fair
Tokyo 1964	11 July 1962	A4. 48 pages	5,000	Asian Games
Sports Facilities	24 Apr. 1962	A4. 32 pages	3,000	IOC General Session, Moscow
The Window of the Government	1 June 1962	B4.	5,000	Olympic Day
Leaflet No. 2	6 Nov. 1962	10x20 2 pages	2,000	For general distribution
Introduction Tokyo 1964	20 Aug. 1962	B5. 34 pages	6,000	For visitors
The path to the Tokyo Olympic Games	22 Sept. 1962	A6. 16 pages	10,000	Olympic Day
The overall programme	29 Jan. 1963	B5. 52 pages	5,000	Tokyo Int'l Trade Fair
The Window of the Government	7 June 1963	B4.	5,000	Olympic Day
Olympic Guide Book	9 Sept. 1963	A6. 29 pages	11,000	Yamaguchi National Athletic Meet
Tokyo Olympics	10 Mar. 1964	A6. 24 pages	2,000	Niigata National Athletic Meet

distributed to visitors coming to Tokyo during the Olympics. This was done in anticipation of greater demands for Olympic information materials from visiting foreign teams and members of the press. As predicted, a considerable demand for these bulletins came from the Press Centre, just before the Games opened, and this pre-planning made it possible to satisfy these requests.

The graphic design for the foreign language bulletin was by the Japan Design Center (represented by Mr. Hiromu Hara). The layout and lettering on the cover was modernistic and the entire layout carefully planned to give a pleasing impression to the foreign reader.

The Official Guidebook and Handbook A survey of past Olympic Games, disclosed that in a number of cases, too much printed information had been made available to the visiting teams and members of the press, and offered to the general public. So numerous had these publications, in anticipation of profit from the Olympics, been, that when the foreign delegates returned home, considerable quantities were found left behind in the Olympic Village.

Mindful of these past experiences, the Organizing Committee decided to limit publications to an official souvenir book and the handbook. The Handbook accepted was one offered by Dentsu Advertising Ltd. and published by the Organizing Committee; and the Official Souvenir published by Dentsu Advertising Ltd. under the supervision of the Organizing Committee.

The handbook, by its very nature was required to be compact and easy to carry. The information had to be concise, yet embracing all necessary items. Care was taken in editing to fill the needs of all groups of people who both directly and indirectly would be involved in administering and programming the Tokyo Games.

The Souvenir book on the other hand was required to be a more attractive edition. The finished book was an impressive 1,000 page B.4 sized edition and containing the history of the modern Olympics, explanations of the twenty events programmed and an introduction to Tokyo the host city. It also included illustrated literary articles on Japan's industry, culture and tourism. The Organizing Committee received without charge from Messrs. Dentsu Advertising Ltd. 10,000 Souvenir books (Japanese edition) and 10,000 copies altogether of the English and French editions, in all 20,000 copies. These were in turn presented to the contestants, officials, members of the press, the IOC, NOC's, IF's and others involved with the Games.

In spite of the precautions of the Organizing Committee to prevent an overproduction of Olympic publications, by the time the Tokyo Olympics

actually opened, it was found that a considerable volume of printed material was finding its way to the Press Centre and the Olympic Village. These were not, however, excessive in number, and many were well produced as pictorials, literary works and guidebooks.

Other Public Relations

In addition to these official publications, the Organizing Committee printed and distributed from 1960 up to the actual Games a number of supplementary public relations materials. (See table on page 364)

Films

Films, both 16 mm. and 35 mm. were used to enhance the public image of the approaching Tokyo Olympic Games, both within Japan and abroad. In May 1962, a Japanese language narrative-feature short on a historical Olympic theme was released in theatres throughout Japan. In September 1962, an informative film on the Olympic preparations was prepared, both in French and English editions, and shown on television networks overseas.

In April 1964, with the Games preparations in the final phase, a 30 minute film showing the extent of Japan's preparedness was issued in both 16 mm. and 35 mm. editions. Entitled "Start to Glory", this Japanese language film was intended to arouse the interest of the general public in the forthcoming Tokyo Olympic Games.

Olympic Public Relations at Local Gatherings

From 1962, the National Sports Festivals (at Akita, Okayama, Yamaguchi and Niigata) were taken advantage of to distribute pamphlets and sponsor lectures. Publicity booths were set up at the International Trade Fairs both in Tokyo and Osaka. June 23, each year, was named an "Olympic Day" and lectures on relevant topics were sponsored and promoted.

Publication of "Results of the Games of the XVIII Olympiad Tokyo 1964"

The press division assembled the entire results of the 20 Games from the preliminaries to the finals and had these edited and book-bound as the Games proceeded. These were distributed in completed form to all the teams and members of the press, immediately after the Games closed.

This form of compiled records first made its appearance at the Winter Games held at Innsbruck,

Austria, in January of the same year. Inasmuch as the scale of the Summer Games was so much larger, with much greater participation of athletes in a much wider programme of events, the plan to compile and publish the full results in such a short period was an undertaking of considerable magnitude. Of the four volumes involved, the first was finished on 23rd October. The total four volumes, of 3,000 copies each, were completed by 27th October. These were presented to the members of the foreign teams and the press corps as they left for home. Many enquires for the volumes came from leaders of the teams and press members who had already returned, as well as from NOC's, IF's, etc., and copies of the completed sets were forwarded by post to meet these requests.

Brief description of these four volumes:

The text was in Romanized Japanese, English and French, in offset printing on both sides of the paper. 3,000 copies were printed of each of the four volumes.

Contents of each volume;

- First: Rowing, Weight-Lifting, Wrestling, Swimming & Diving, Modern Pentathlon, Water-Polo
- Second: Athletics, Canoeing, Cycling, Shooting, Yachting
- Third: Basket-Ball, Boxing, Football, Hockey, Volley-Ball
- Fourth: Fencing, Gymnastics, Judo, Equestrian Sports

Information Service

The information service for the Tokyo Games was arranged in the following pattern by the Organizing Committee.

Olympic Village The Information Centre, village enquiry office, transportation guidance office and training venues office were set up within the

Olympic Village to handle inquiries of athletes, officials and the general public.

Press Centre Printed schedules for the entire Games and daily programmes were distributed. Transportation was provided to all venues of the Games and training venues, for foreign members of the press. For TV and radio coverage, similar services were made available at the Broadcasting Centre through the Press Centre.

Members of the Japan Junior Chamber of Commerce and Industry were regularly stationed at the Press Centre to provide information to foreign press members on facts pertaining to Japan's industry and to act as guides in making tours to various industrial plants.

At Stadiums and Other Venues At all games venues, Stadium Section provided guidance to general spectators and as well handled any misunderstandings as to seating allotments.

In the neighbourhood of Games Sites The Ticket Section posted guides in the neighbourhood of all venues to assist spectators in getting to the programmed place on time.

OOC Information Centre The Olympic Games Information Centre was established within the former Akasaka Detached Palace to service the telephoned inquiries from the general public during the period of the Games. From October 1 until after the closing ceremony this centre provided a daily service from 8 a.m. to 8 p.m. This was made possible by a staff of 28 persons from the Hakuodo Incorporated Advertising, all of which were fluent in Japanese, English and French. This special service entailed the use of ten newly installed circuits. (This information centre is further described in the 'Communication' section of this report.)

The Information Centre at the Akasaka Detached Palace kept telephone operators fully occupied



Publicity was an important factor—



—Bulletins in Japanese



—and in English and French

The five Olympic Posters



Butterfly swimmer

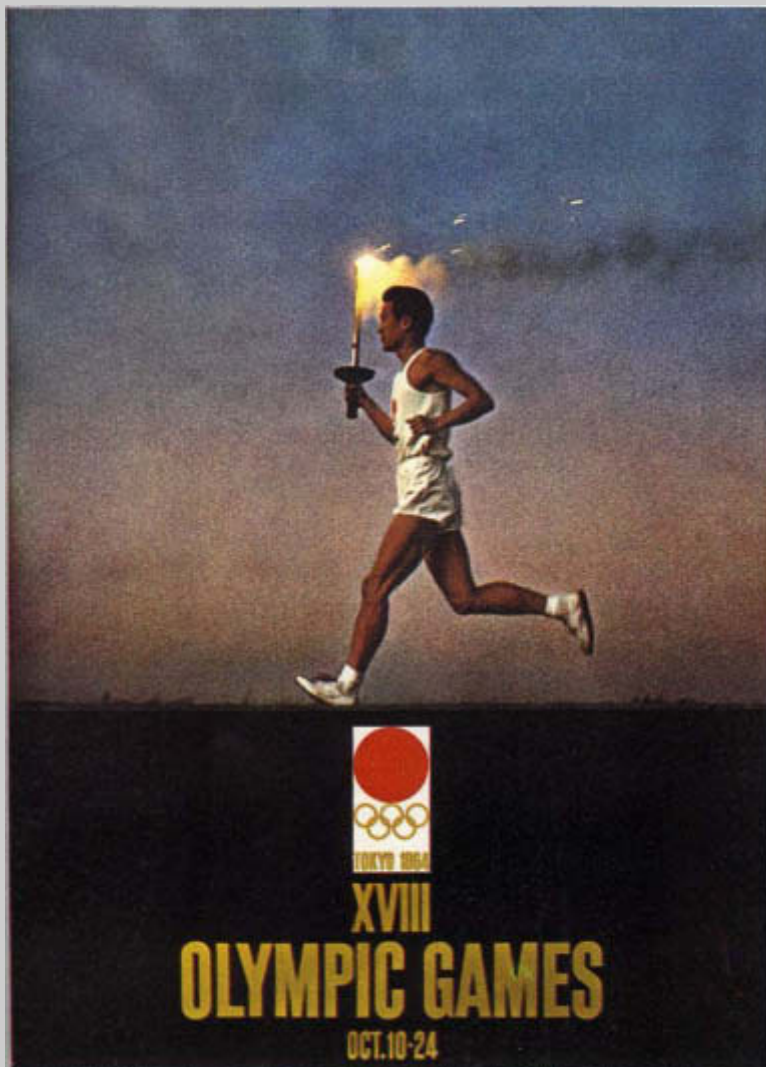

Torch relay

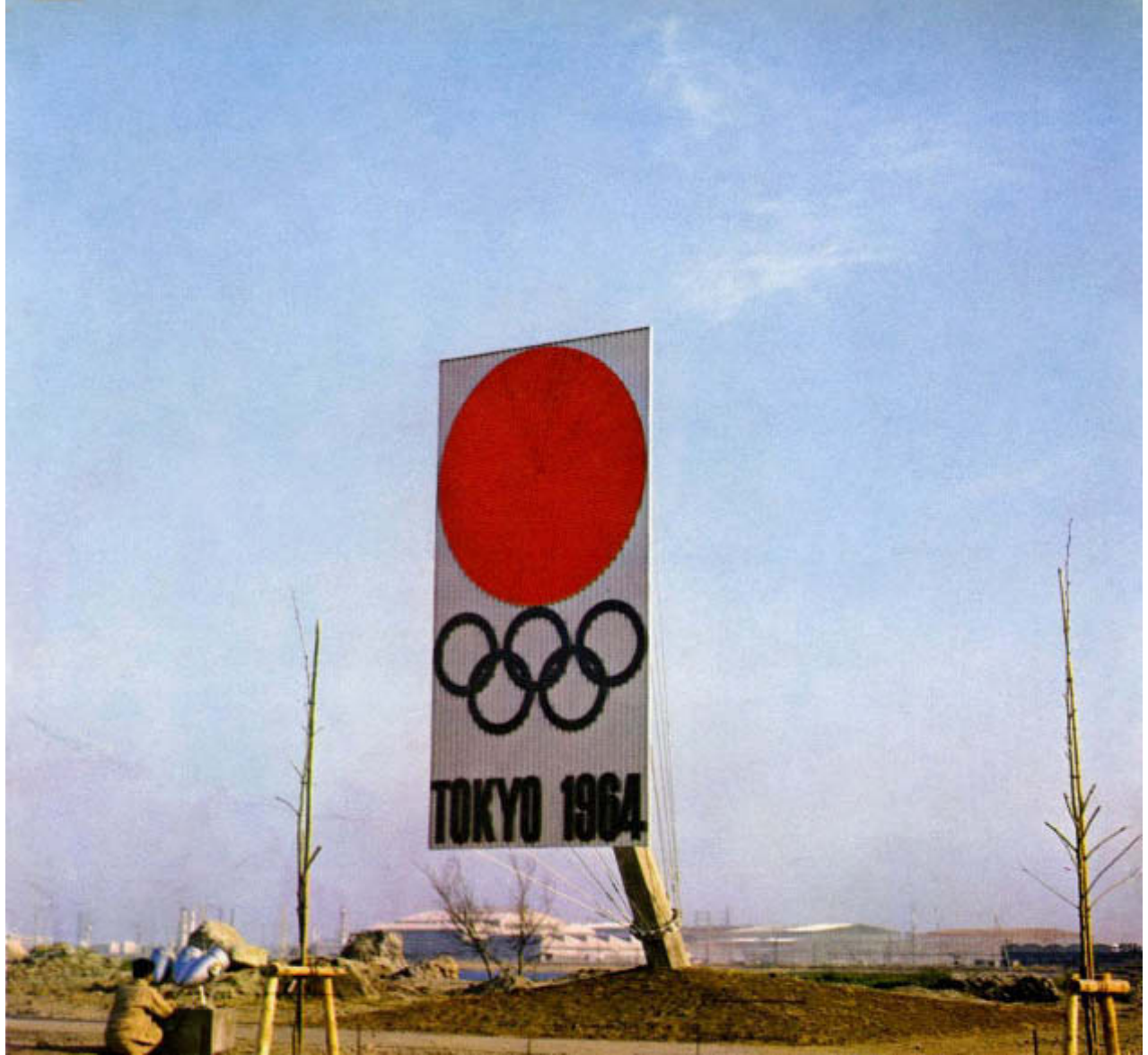

Huge sign-board erected at the Tokyo International Airport

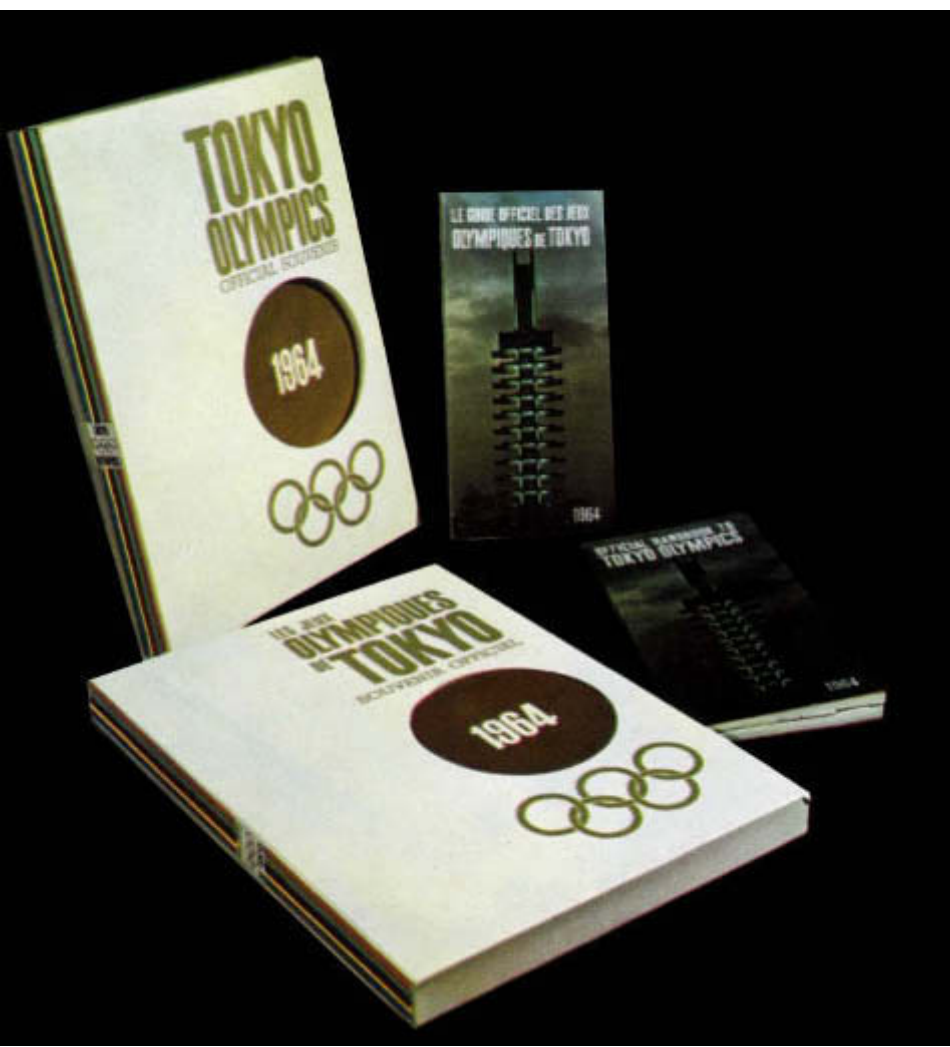

Official souvenir book and pamphlet

PRESS

The responsibilities entrusted to the Press Section of the Organizing Committee covered a wide range of duties ranging from the allocation of "ID" cards to domestic and foreign correspondents, broadcasters, cameramen, to the provision of seats for press personnel, announcers, and cameramen in all the venues of the sports, the management of the Press Centre and the Press House, the organization of the photo pool, the prompt reporting of the games results by the electronic computer, the arrangements for taking of pictures from the air, the utilization of industrial television, and a number of subsidiary tasks involved therewith. Every possible facility was extended to press personnel covering the Games, and with the willing cooperation of those concerned at all levels both in Japan and overseas, this Division was enabled to accomplish the goals it set out to achieve.

Allocation of ID Cards

Identification cards were made available to the following agencies and persons engaged in reporting:

- Foreign news agencies
- Domestic news agencies
- Foreign broadcasting personnel

- Cameramen of foreign newsmedia
- Cameramen of domestic newsmedia
- Pooled cameramen of domestic and foreign newsmedia

The following groups were provided with specific assignment cards:—

- Domestic broadcasting staff
- 16mm news cameramen
- 35mm news cameramen
- Documentary film staff

Specific assignment cards were, in some cases, used together with ID cards, or they were included in the number of the ID cards allotted.

Allocation of cards to foreign journalists The work involving the allocation of ID cards to foreign journalists for the Tokyo Olympic Games was actually begun in the first half of 1963 by the Press Section of the Organizing Committee. The selection of eligible newspapers and news agencies was left to the National Olympic Committees in the various countries. International news agencies were issued cards on the same basis as had prevailed at the previous Olympic Games in Rome, and this allocation was made directly by the Press Section. In making these allocations the number of ID cards issued to each of the countries which took part in

Table showing number of ID cards issued to Press Personnel

Country	Press	Photograph	Country	Press	Photograph	Country	Press	Photograph
Afghanistan	1	0	Israel	4	0	Thailand	9	0
Argentina	12	0	Italy	51	2	Trinidad & Tobago	2	0
Australia	23	5	Jamaica	1	0	Tunisia	0	1
Austria	3	2	Kenya	2	0	Turkey	2	1
Belgium	8	0	Korea	27	4	U.A.R.	6	0
Bolivia	1	1	Lebanon	3	0	Uruguay	2	0
Brazil	15	2	Libya	1	0	U.S.A.	79	27
Bulgaria	2	0	Malaysia	6	0	U.S.S.R.	53	6
Cameroon	0	1	Mexico	16	1	Venezuela	1	0
Canada	10	0	Mongolia	1	0	Viet Nam	4	0
Ceylon	1	0	Morocco	1	0	Yugoslavia	11	0
Chile	1	0	Netherlands	18	1	Sub-Total	803	109
Colombia	2	0	New Zealand	6	1	Japan	350	70
Cuba	2	0	Nigeria	3	0	Total	1,153	179
Czechoslovakia	8	2	North Korea	11	2			
Denmark	18	2	Norway	16	1	AP	25	10
Dominican Republic	1	0	Pakistan	3	0	UPI	20	10
Finland	22	4	Panama	1	1	AFP	20	0
France	43	5	Peru	2	0	Reuters	20	0
Germany (West)	10	2	Philippines	11	1	TASS	12	0
Germany (East)	55	13	Poland	14	1	SID	9	0
Ghana	1	0	Portugal	5	0	DPA	9	2
Great Britain	51	3	Puerto Rico	2	0	Keyston	0	8
Greece	6	0	Rhodesia	1	0	EPU	0	7
Hong Kong	6	3	Rumania	5	0	PANA	0	2
Hungary	11	1	South Africa	2	0	IOPP (AP, UPI, EPU, Keyston)	0	21
India	14	2	Spain	10	0	Total	115	60
Indonesia	9	3	Sweden	32	6			
Iran	4	0	Switzerland	15	0			
Ireland	4	0	Taiwan	10	2			



Busy Press Seats in the National Stadium

the Rome and previous Olympic Games were taken into consideration. In view of the fact that the Tokyo Games would involve a considerable amount of travel from many countries, the number of cards to be allotted was decided during September 1963. For the fourteen countries which were newly recognized by the IOC since the Rome Olympics, a decision was made tentatively to issue one ID card to each country, and each NOC involved was notified to that effect on 1st October by this Committee. A number of requests were subsequently received from some countries to increase the number of cards, and at the end of March 1964 a final ruling was given after careful consideration of all the factors involved in each case.

These allotments were all made under the relevant stipulations of Article 48 of the Olympic Charter. Decisions regarding the most equitable method of allotment proved most difficult as indeed it had been found in previous Games. Even after the Foreign Press Room was set up in the Organizing Committee, requests for additional allocations of ID cards were received continually from foreign NOC's or from individuals directly. In principle the Foreign Press Room declined all the private requests, making only a very small number of exceptions for specific requests from those NOC's which appeared to have extenuating circumstances. Some few of the newly IOC recognized countries

failed to reply to the Organizing Committee's written or telegraphic information on the allotted cards or requests for details of organization to whom it had been allotted. Certain NOC's requested that if no further ID cards could be made available, that they be supplied with cards effective for only one specific sport in which that country was especially interested. A certain number of such ID cards for a single sport, to be delivered at Tokyo, were agreed upon in addition to the cards allotted to the NOC's. These were mainly issued for yachting and equestrian sports. The actual numbers of the cards officially issued from the Foreign Press Room up to 24th October, the day of the Closing Ceremony, will be found listed in the table in this section.

Allocation of ID cards to domestic journalists

The active interest and the considerable size of the staff of Japanese news agencies posed a significant problem in making an equitable allocation of official ID cards, and the situation which prevailed at previous Olympic Games was found not to have a parallel in the conditions in Japan. Seats were limited, and a balance was required to be kept in the facilities afforded to Japanese and foreign journalists. The table herein shows the actual allotments of cards under this heading.

Allocation to foreign broadcasting staffs NHK acted as the agent for the basic allocation of cards for overseas broadcasting personnel and performed a most difficult task with efficiency and to the apparent satisfaction of all concerned. This is dealt with in more detail under the Chapters on Broadcasting.

Specific Assignment Cards

A special specific assignment card system was arranged in order to make the maximum use of the seating capacity reserved for press personnel, and to supplement the ID card issue, thus to ensure the most equitable use of the seats available. The following four kinds of cards under the heading were issued to different categories of people:—

- (1) for press personnel.
- (2) for cameramen of newspapers, 35mm, and 16 mm news films.
- (3) for producers and cameramen of the documentary film produced by the Organizing Committee.
- (4) for broadcasting staffs.

Entrance regulations for assignment and ID cards

After considering carefully all the factors involved, the Organizing Committee divided the events roughly into two groups viz:— Group A being those to which news personnel would be expected to cover thoroughly and Group B for those sports which would not be expected to arouse such universal interest.

For these two groups the ID and the special assignment cards were treated somewhat differently:—

Card		Opening & Closing Ceremonies	Venue of Group A	Venue of Group B
PRESS	Domestic	Specific assignment cards (also ID card)	Specific assignment card for each venue	Specific assignment card for each venue
	Foreign	"	"	ID card
PHOTO FILM	Domestic	"	"	Specific assignment card for each venue
	Foreign	"	"	ID card
OLYMPIC FILM		Specific assignment card	"	Specific assignment card
RADIO & TV	Domestic	"	"	"
	Foreign	Specific assignment card (also ID card)	Specific assignment man's card for each venue	ID card

Note: At the Opening and Closing Ceremonies, the production and showing of both the specific assignment card and the ID card was required to obtain admission.

The Group A and B of venues were as follows:—

Venues of Group A

	Venue	Sport
1	National Stadium	Athletics
2	Metropolitan Tokyo Gymnasium	Gymnastics
3	Komazawa Volley-Ball Court	Volley-Ball
4	Yokohama Cultural Gymnasium	"
5	National Gymnasium, Main Hall	Swimming, Diving
6	National Gymnasium, Annex	Basket-Ball
7	Korakuen Ice Palace	Boxing
8	Shibuya Public Hall	Weight-Lifting
9	Komazawa Gymnasium	Wrestling
10	Nippon Budokan Hall	Judo

Venues of Group B

	Venue	Sport
1	Metropolitan Tokyo Gymnasium, Indoor Swimming Pool	Water-Polo
2	Prince Chichibu Rugby Field	Football
3	National Stadium	Football
4	Mitsuzawa Football Field	"
5	Omiya Football Field	"
6	Komazawa Stadium	"
7	Komazawa 1st Hockey Ground	Hockey
8	Komazawa 2nd Hockey Ground	"
9	Komazawa 3rd Hockey Ground	"
10	Waseda Memorial Hall	Fencing
11	Equestrian Park	Equestrian Sports
12	Playing Grounds of Kemigawa Tokyo University	Modern Pentathlon (Cross Country)
13	Asaka Nezu Park	(Equestrian Sports)
14	Asaka Shooting Range	Shooting (Rifle)
15	Tokorozawa Shooting Range	Shooting (Clay)
16	Hachioji Velodrome	Cycling (Pist)
17	Hachioji Road Race Course	Cycling (Road)
18	Toda Rowing Course	Rowing
19	Enoshima Yacht Harbour	Yachting
20	Lake Sagami	Canoeing
21	Karuizawa Equestrian Park	Equestrian Sports

Provision of Seats for Reporters, Broadcasters, and Cameramen

In arranging equitable allocations, the Press Section sought the opinions of all concerned before making decisions. Particular importance was attached to
Seats for Journalists

the advice of the Special Press Committee of the Organizing Committee. Drafts to be submitted to that Committee had been the subject of repeated discussions, with all branches of the news media, the Japan Newspaper Publishers and Editors Association, the Japan Broadcasting Corporation, the

Venue	Sports	Seats with desks	Seats without desks	Total
National Stadium	Opening & Closing Ceremonies, } Equestrian Sports	699	350	1,049
Toda Rowing Course	Athletics	699	0	699
National Gymnasium Annex	Rowing	118	90	208
Korakuen Ice Palace	Basket-Ball	159	0	159
Lake Sagami	Boxing	110	44	154
Hachioji Velodrome	Canoeing	50	30	80
Hachioji Cycling Road Race Course	Cycling (Pist)	60	80	140
Waseda Memorial Hall	Cycling (Road)	100	24	124
National Stadium	Fencing	72	96	168
Prince Chichibu Memorial Football Field	Football	699	0	699
Komazawa Stadium	Football	107	93	200
Mitsuzawa Football Field	Football	108	97	205
Omiya Football Field	Football	72	80	152
Tokyo Metropolitan Gymnasium	Football	120	56	176
Shibuya Public Hall	Gymnastics	156	152	308
Komazawa 1st Hockey Field	Weight-Lifting	63	51	114
Komazawa 2nd Hockey Field	Hockey	52	48	100
Komazawa 3rd Hockey Field	Hockey	60	73	133
Nippon Budokan Hall	Hockey	40	40	80
Komazawa Gymnasium	Judo	120	170	290
National Gymnasium	Wrestling	160	18	178
Asaka Nezu Park	Swimming & Diving	159	407	566
Tokyo University Kemigawa Playing Ground	Modern Pentathlon (Equestrian)	50	0	50
Karuizawa Equestrian Events Ground	Modern Pentathlon (Cross Country)	50	0	50
Equestrian Park	Equestrian Sports	70	40	110
Asaka Shooting Range	Equestrian Sports	206	0	206
Tokorozawa Clay Shooting Range	Shooting (Rifle) (Modern Pentathlon)	50	0	50
Komazawa Volley-Ball Court	Shooting (Clay)	20	6	26
Yokohama Cultural Gymnasium	Volley-Ball	100	225	325
Tokyo Metropolitan Indoor Swimming Pool	Volley-Ball	84	135	219
Enoshima Yacht Harbour	Water-Polo	65	36	101
	Yachting	1 boat for 30 journalists—6 boats		180

Seats for Press Cameramen

Venue	Sports	Seats
National Stadium	Opening & Closing Ceremonies, } Equestrian Sports	192
National Gymnasium Annex	Athletic	188
Korakuen Ice Palace	Basket-Ball	30
Tokyo Metropolitan Gymnasium	Boxing	40
Shibuya Public Hall	Gymnastics	64
Nippon Budokan Hall	Weight-Lifting	44
Komazawa Gymnasium	Judo	160
National Gymnasium	Wrestling	34
Komazawa Volley-Ball Court	Swimming ,Diving	87
Yokohama Cultural Gymnasium	Volley-Ball	40
Toda Rowing Course	Volley-Ball	29
Lake Sagami	Rowing	14
Hachioji Velodrome	Canoeing	8
Hachioji Cycling Road Race Course	Cycling (Pist)	26
Waseda Memorial Hall	Cycling (Road)	12+standing seat
National Stadium	Fencing	40
Komazawa Stadium	Football	188
Prince Chichibu Memorial Football Field	Football	40
Mitsuzawa Football Field	Football	Field
Omiya Football Field	Football	"
Komazawa 1st Hockey Ground	Hockey	"
Komazawa 2nd Hockey Field	Hockey	"
Komazawa 3rd Hockey Field	Hockey	"
Karuizawa Equestrian Events Ground	Equestrian Sports	8
Equestrian Park	Equestrian Sports	standing seat
Tokorozawa Clay Shooting Range	Shooting (Clay)	6
Asaka Shooting Range	Shooting (Rifle)	standing seat
Tokyo University Kemigawa Playing Grounds	Modern Pentathlon	"
Asaka Nezu Park	Modern Pentathlon	"
Tokyo Metropolitan Indoor Swimming Pool	Water-Polo	10
Enoshima Yacht Harbour	Yachting	Boarding together in 6 boats

National Association of Commercial Broadcasters in Japan, and the Tokyo Olympic Film Association. This work had been carried out for two years from the end of 1962, to ensure that preparations might be as complete as possible.

Demands for news and material in Japan reached a climax, inasmuch as the Olympic Games in Tokyo attracted the greater interest of more Asian countries than previously, and this in turn stimulated other foreign countries to send more correspondents. Under these circumstances, a considerable increase in specific assignment seats was attempted, though the allocation of these on a satisfactory basis presented a number of significant problems.

Journalists' seats (including News Agencies) In consideration of past experience and also to comply with a general desire of those concerned, seats with a desk were prepared to facilitate the writing of reports, typewriting, and for telephone communication.

Broadcasting seats The number of the broadcasting seats was decided by NHK, which organization had been designated as a unified agency for liaison, both domestic and foreign, and had coordinated requests from foreign countries.

In view of the necessity for the broadcasting

equipment and the activity of assistants and technicians, four seats for each broadcasting corporation were in principle allocated. A listing of them will be found on these pages.

Seats for news cameramen Some difficulty was experienced in providing cameramen with effective seats, for technically, camera angles were multifarious. Equitable solutions were in most cases found, and in a number of cases the assistance of the International Sports Federations concerned had to be obtained to allow minor adjustments to the stipulated conditions of numbers and positions.

Seats for 16mm news films If all the persons wishing to take 16mm cameras into the stands had been accommodated, extremely few seats would have been left for general spectators. Accordingly, NHK was made the main body with the right of representation to foreign countries, and in compliance with worldwide demands, a structure was set up for the supply of films at a low cost. To the main body was added a group of cameramen of commercial broadcasting corporations, the management of which was entrusted to NHK.

Seats for 35mm news films In the same way as 16mm news films, the taking of 35mm news films

Seats reserved for News Film Personnel (16mm, 35mm) and Documentary Film Cameramen

Venue	Sports	16mm	35mm	Documentary Film
National Stadium	Opening & Closing Ceremonies, } Equestrian Sports }	92	114	161
National Gymnasium Annex	Athletics	73	84	171
Korakuen Ice Palace	Basket-Ball	8	10	25
Tokyo Metropolitan Gymnasium	Boxing	4	6	6
Shibuya Public Hall	Gymnastics	12	12	26
Nippon Budokan Hall	Weight-Lifting	4	5	16
Komazawa Gymnasium	Judo	8	8	8
National Gymnasium	Wrestling	24	24	24
Komazawa Volley-Ball Court	Swimming & Diving	20	23	20
Yokohama Cultural Gymnasium	Volley-Ball	9	11	24
Toda Rowing Course	Volley-Ball	14	14	17
Lake Sagami	Rowing	4	4	4
Hachioji Cycling Road Race Course	Canoeing	4	4	6
Hachioji Velodrome	Cycling (Road)	60	35	12
Waseda Memorial Hall	Cycling (Pist)	3	3	4
National Stadium	Fencing	8	8	24
Komazawa Stadium	Football	66	86	91
Prince Chichibu Memorial Football Field	Football	38	30	51
Mitsuzawa Football Field	Football	8	9	6
Omiya Football Field	Football	10	10	12
Komazawa 1st Hockey Ground	Football	15	6	12
Komazawa 2nd Hockey Ground	Hockey	10	10	12
Komazawa 3rd Hockey Ground	Hockey	32	32	30
Karuizawa Equestrian Events Ground	Hockey	4	4	standing seat
Equestrian Park	Equestrian Sports	8	4	8
Tokorozawa Clay Shooting Range	Equestrian Sports	12	13	standing seat
Asaka Shooting Range	Shooting (Clay)	standing seat	standing seat	"
Tokyo University Kemigawa Playing Grounds	Shooting (Rifle)	"	"	"
Asaka Nezu Park	Modern Pentathlon	"	"	"
Tokyo Metropolitan Indoor Swimming Pool	Modern Pentathlon	"	"	"
Enoshima Yacht Harbour	Water-Polo	4	4	13
	Yachting	Boarding Film Boat	Boarding Film Boat	Boarding Film Boat

Seats for Special Cameramen (for close-up pictures of certain events)

Sports	Venue	Press	TV	16mm	35mm	Docu- mentary Film
Opening & Closing Ceremonies	National Stadium	6	1	3	2	2
Athletics	National Stadium	6	2	3	1	3
Cycling	Hachioji Velodrome	4	1	1	2	1
	Hachioji Cycling Road Race Course	2	1	1	1	5
Football	National Stadium	12	1	2	2	4
	Prince Chichibu Memorial Football Field	12	1	2	2	4
	Komazawa Stadium	12	1	2	2	4
	Mitsuzawa Football Field	12	1	2	2	2
	Omiya Football Field	12	1	2	2	2
Hockey	Komazawa 1st Hockey Ground	4		2	2	2
	Komazawa 2nd Hockey Ground	4		2		2
	Komazawa 3rd Hockey Ground	4		2		2
Equestrian Sports	Karuizawa Equestrian Events Ground	4		6		4
	Equestrian Park	4	1			4
	National Stadium		1			1
Shooting	Asaka Shooting Range	4		2	1	2
	Tokorozawa Clay Shooting Range	4		2	1	2
Modern Pentathlon	Asaka Shooting Range	4		2	1	2
	Tokyo University Kemigawa Playing Grounds	4		2	3	
	National Gymnasium	6		2	2	1
	Waseda Memorial Hall	4		1	1	4
	Asaka Nezu Park	4		2	3	
Basket-Ball	National Gymnasium Annex	4	2	2	2	2
Boxing	Korakuen Ice Palace	6	1	1	1	1
Fencing	Waseda Memorial Hall	4	2	1	1	4
Gymnastics	Tokyo Metropolitan Gymnasium	6	1	2	2	2
Weight-Lifting	Shibuya Public Hall	4	1	1	1	4
Judo	Nippon Budokan Hall	8	1	3	3	3
Wrestling	Komazawa Gymnasium	4	1	1	1	2
Swimming & Diving	National Gymnasium	6	1	2	2	3
Volley-Ball	Komazawa Volley-Ball Court	4	1	2	2	2
	Yokohama Cultural Gymnasium	4	1	1	1	2
Water-Polo	Tokyo Metropolitan Indoor Swimming Pool	4	1	1	1	1
Rowing	Toda Rowing Course	6	7	5	1	5
Canoeing	Lake Sagami	6		3	1	3
Yachting	Enoshima Yacht Harbour	8	1	3	1	3

Radio and Television Seats

Sports	Seats
Opening & Closing Ceremonies	80
Athletics	80
Football (Prince Chichibu M. F. F.)	14
Gymnastics	25
Water-Polo	14
Swimming & Diving	50
Basket-Ball	20
Weight-Lifting	20
Football	16
Wrestling	21
Volley-Ball (Komazawa)	20
Volley-Ball (Yokohama)	16
Hockey 1.	11
Hockey 2.	13
Hockey 3.	10
Rowing	32
Fencing	22
Boxing	35
Cycling (Road)	25
Cycling (Pist)	25
Modern Pentathlon (Cross Country)	4
Modern Pentathlon (Equestrian Events)	3
Shooting (Rifle)	8
Shooting (Clay)	8
Equestrian Sports (Grand Prix Dressage)	16
(Jumping)	7
(Endurance)	7
Yachting	8
Canoeing	10
Football (Mitsuzawa)	10
Football (Omiya)	9
Judo	25

and their distribution were entrusted to the "Tokyo Olympic News Film Association" formed by seven representative news film companies in Japan. Both 16mm and 35mm films were taken by representative cameramen, so that the matter was greatly simplified.

Seats for TV relay cameras NHK was entrusted by the Organizing Committee to collect material for TV relays, and these were distributed from the Broadcasting Centre. Positions for TV cameras were made the subject of careful study for much space was taken up by the bulky equipment involved.

Seats for cameras to take documentary films The work of Director Kon Ichikawa had commenced in earnest only ten months before the Olympic Games, and it was not found easy to co-ordinate work which had been begun by other cameramen. As positions for cameras were very competitive, a representative Committee was organized and their negotiations were much appreci-

ated. A list seat allocation for 16mm and 35mm news films will be found herein.

Use of the Elevating Camera Stand

For the Opening and Closing Ceremonies, the taking of photographs near the Royal Box had to be properly regulated. For reporting and documentary purposes, it was impossible to place a total ban on the taking of pictures in that vicinity and cameras for documentary films, 16mm and 35mm news films, and for newspaper photographs, were set on four hydraulic elevators in the field facing the Royal Box. In view of the speciality of TV relaying cameras, a crane system was devised and cameras were raised to take pictures when this would not disturb the performance of the Ceremonies. This method worked very satisfactorily and is one which could with advantage be adopted in future Games.

The Press Centre

The centre of activities for preparation of news and transmission of news media was the Press Centre, set up in the Japan Youth Hall. For press personnel the Press Centre, adjacent to the main stadium was ideally situated. The following facilities were provided:—

On the 1st floor: the IBM data centre with its auxiliary installations, facilitating the collection and arrangement of the results of sports coming from the venues, the listing of competitors issued by the Sport Section of the Organizing Committee and the respective International Sports Federations.

On the 2nd floor: the Press Headquarters of the Organizing Committee, office of press information, pigeon holes, post office, air cargo agency, bank,



The oil pressure camera hoist in front of the Royal Box

data printing room, telephone exchange, and room for photo printing service.

On the 3rd floor: the presswork room, stands for flash reports, International Telephone and Telegram facilities, and snack bar.

On the 4th floor: temporary offices of foreign news agencies (Reuter, AAP, NZPA, and TT).

Sub-Press Centres

In addition to the Press Centre, three sub-press centres with presswork rooms, International Telephone and Telegram services, and snack bars were set up at the following places:—

- a. The National Stadium and main venues (for the Opening and Closing Ceremonies, Athletics, and Grand Prix equestrian events).
- b. The National Gymnasium, Main Hall (for Swimming, Diving).
- c. The Komazawa Stadium, Indoor Gymnasium (for Wrestling); Part of the floor under the stands of the main venues was supplied to certain international news agencies.

The building adapted for the Press Centre





A view from the air of the Press House, and (below) the entrance, bar



The Press House

The Press House was established some 150m to the west of the Press Centre. Under arrangements with the Japanese Government, the Japan Housing Corporation constructed an attractive building in a form that could be easily converted later to private dwellings. For the period between September 1 and November 30, the Organizing Committee rented this seven-storied building constructed at an expense of 560 million Yen (US\$1,555,556). This was subsequently converted into 169 apartments.

During the time the Press House was open, the service and dining facilities were entrusted to private organizations. The total number of employees numbered 480, while the total number of press personnel registered in the days during which the Press House operated, totalled 16,889, the highest record for any one day being 789 persons. The accommodation with three meals a day cost ¥1,980 (\$5.50), and of this amount the Organizing Committee contributed ¥720 (\$2.00) a day for each guest.

Activity of Domestic and Foreign Photo Poolers

Necessity for photographing by pools The pooling system of photographs taken by designated cameramen, is usually adopted when it is necessary to restrict numbers. At the Tokyo Games, the maximum number of cameramen for each field, floor, or other venue was fixed, necessitating pooling to



achieve maximum results with minimum personnel.

Formation of pools With due consideration to the lively interest from the public in the photographs, the Organizing Committee entrusted the formation of the domestic pool for sport pictures to a special committee of the Japan Newspaper Publishers and Editors Association. At the same time, the Organizing Committee set up its own committee to define the policy concerning the formation of

pools. This policy in principle was decided as follows:—

- a. The pool cameraman would be permitted as much freedom as possible in taking pictures provided his activities did not interfere with the conducting of the sport.
- b. The number of the cameramen at each venue would be decided by negotiation with each National Sport Federation.
- c. The pool cameraman would carry a special badge or arm band authenticated by the Organizing Committee to distinguish him from other news cameramen. Only those personnel so equipped would be authorized to take pictures near where the actual events were taking place.
- d. The pool cameraman would mainly shoot events at each venue and his photographs would be distributed on an equal basis to all the information media all over the world.
- e. The pool cameraman's photographs would be supplied free of charge to the Organizing Committee if it so requested.

Composition of the pool system:

- a. The special character of the Japanese press media was given careful consideration, as also were the examples of reporting which prevailed at the Melbourne and Rome Olympic Games, and a decision was reached that for the Tokyo Games the most equitable system would be achieved by two pool camera teams, one domestic and the other for international purposes.
- b. Each team was to be composed of twenty cameramen, and would have a few additional authorized personnel for compilation, dark rooms, and liaison, specifically attached to that section.
- c. Pool cameramen belonging to the domestic and international teams would work in co-operation with each other and make each other photographs available from time to time.
- d. Expenses for the personnel working for the pool system and the necessary material, would be borne by the domestic and international teams, while the Organizing Committee would supply the pool system with suitable space and facilities for its activities.

The Organizing Committee for instance, provided space at the swimming pool of the National Stadium of approximately 800 square metres: 138.6 square metres to the domestic poolers and 160.0 square metres to the international poolers.

Space was also provided for four separate organizations for the convenience of their foreign cameramen viz.:— 132 square metres to UPI,

146.88 square metres to AP, 128.18 square metres to EPU, and 95.7 square metres to Keystone.

Activity of the domestic pool After several discussions it was decided in April 1963 to make the Kyodo News Agency the nucleus of the picture pool system of the domestic team, and subsequently it was decided to set up the Tokyo Olympic Picture Association with 67 members and a budget of 9,730 thousand Yen (US\$27,028) which figure was to include the expenses for personnel, material, dark rooms, vehicles, collection of picture material and the expenses during the Torch Relay, etc. More than half of these expenses were borne by the Kyodo News Agency, and the remainder was shared by 11 newspapers, i.e., the Asahi, Mainichi, Yomiuri, Hochi, Nihon Keizai, Chubu Nippon, Sankei, Sports Daily, Sports Nippon, and the Asahi Evening News, and NHK. The management was entrusted to Kyodo.

The desk and the dark rooms were provided under the Stand of the National Stadium. Centred around a space of 130 square metres, five small dark rooms for negatives and a large dark room for enlargement were prepared, and warm running water provided. These were near the middle of the first and second corners of the track, and thus conveniently situated for the movement of camera-

Camera facilities in the stands

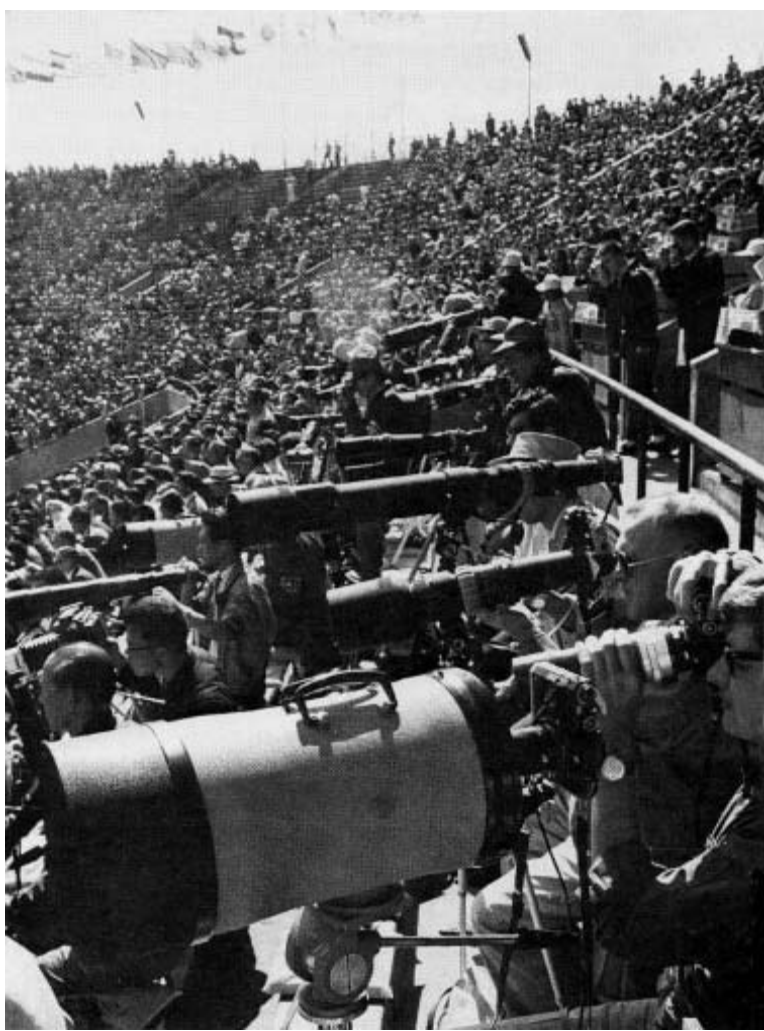

men and transmission of reports to runners and messengers. 35mm Nikon cameras was mainly used, with numbers of auxiliary zoom lenses and single telephoto lenses. For special photographing, the Nikon motor, pan camera, Aimo, Toyoview, and others were made use of. The popular 4X5 speed graphic cameras were not used except for the Opening and Closing Ceremonies. For colour pictures, the 6X6 Mamiya C cameras were selected.

Camera positions for filming sports The main interest and subjects of photographs were the Japanese competitors. In all, 818 pictures were produced, or as many as 54.5 pictures a day on an average. These were distributed by the Press Section of the Organizing Committee free of charge, and were offered in exchange with those taken by the International Olympic Picture Pool (IOPP). The photographs were also distributed serially among Japanese mass communication media including general magazines weeklies, by the Photo Service Co., Ltd. of the Kyodo News Agency.

Number of pictures produced by events during the Olympic Games:

Athletics	254 pictures
Swimming	87
Gymnastics	87
Volley-Ball	41
Wrestling	36
Weight-Lifting	33
Fencing	29
Judo	25
Hockey	23
Opening Ceremony	22
Boxing	22
Closing Ceremony	20
Football	17
Cycling	17
Basket-Ball	16
Rowing	14
Equestrian Sports	13
Water-Polo	12
Yachting	11
Modern Pentathlon	10
Shooting	6
Canoeing	6
Air Photos	10
Miscellaneous Views	7
Total	818
(Daily Average	54.5)

The number of cameras used in the infields are described in Table 4. (The number of the cameramen being the same as the number of camera positions)

Organization of International Photo Pool

In the same way as for the domestic pool, foreign news agencies were informed by the Press Section in April 1963 of the principles to guide the organization of an international photo pool. The Associated Press acted as a central liaison for foreign news agencies and the international pool was organized at the same time as domestic pool.

Activity of international poolers The main object of the international pool was the distribution all over the world through affiliated news agencies of pictures taken in those main venues where cameramen of the pool alone were admitted.

It was, of course, essential that the international pool photographers should take the pictures of competitors of all nationalities. The composition of the international pool, therefore, was intentionally quite international, including 105 members from five corporations: (viz. AP, UPI, Time-Life, Keystone and EPU). These consisted of one coordinator who was in charge, one secretary, 20 cameramen, 10 desk personnel, 8 caption writers, 35 dark-room personnel, 10 liaison men, etc., and this group was provided with 10 motorcycles and 8 motorcars. At previous Olympic Games only three international news agencies at the most have taken part with perhaps half the number of pool photographers.

Necessary expenses were borne equally. Each news agency contributed \$5,500 making a total of \$27,500, to cover the expenses for the 55 cameramen who were temporarily employed in Japan, the cost of films, chemicals and other materials, motorcars, motorcycles, but excluding the travelling expenses to Japan for those members of the pool despatched by the respective news agencies.

The collection of material by the pool was interesting in that colour photographs of almost all the events were taken, and further that, like monochrome photographs, those in colour were developed in the dark rooms in the National Stadium. The volume of work was much larger than had been expected.

The pool's work was begun on 10th October, the day of the Opening Ceremony. It was not surprising that over 100 pictures were produced on that day, followed by a daily average of 150 pictures, to reach 232 at the climax. In addition, on an average more than 300 rolls of films a day were sent in to be treated by the more than 30 persons who were kept fully occupied.

By virtue of its particular composition, being a combined corps of veteran reporters and cameramen from all over the world, the international pool proved a most successful factor to the photographer

recording of the Olympic Games in Tokyo.

Air Photographs

The taking of pictures from the air is a popular medium in Japan. If, however, such photographing had not been strictly controlled, the organization of the Games could have been seriously disturbed by buzzing airplanes, or accidents caused by wind pressure due to low flights or congestion of airplanes. Conferences were held therefore, with people engaged in reporting, aviation, and sports, as well as with the Civil Aviation Bureau of the Transportation Ministry, and control measures for these flights was discussed. It was necessary, however, to photograph and report those scenes worthy of recording for history, and accordingly representative planes to take specific pictures were arranged with the support of the Self-Defense Forces. Throughout the areas of control the hovering of helicopters and slow flights below 35 miles per hour were prohibited.

The control was applied to the Opening and Closing Ceremonies, the Olympic Village, and to all outdoor events, and could be said to be unprecedentedly successful.

Quick Reporting of Records by TV

The Closed Television System was adopted in the athletic venues and swimming pools to provide immediate reporting of results to reporters and sport officials.

As described under other sections of this report, this consisted of an industrial vidicon camera to send pictures and a portable transistor TV to receive them. The camera was set near the seats of the final judges of sport organizations, and the TV receiver (micro "6" TV) was set in the seats of officials and reporters.

System for conveying flash results to the press by closed circuit T.V.

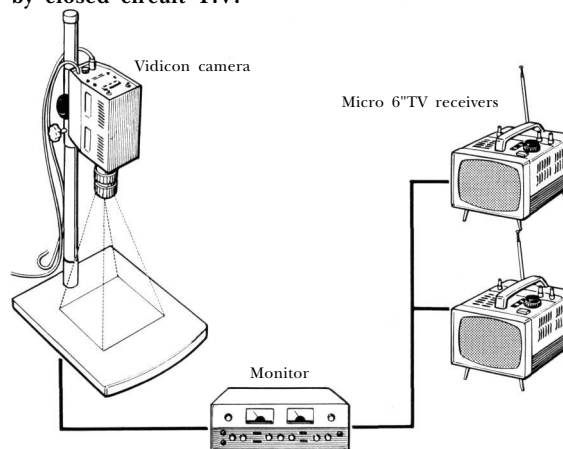

Upon the announcement of the results of a race by the final judges, a copy was sent by the vidicon camera, and the same image appeared on the receivers of the officials and the reporters. As transmission was done quicker than any other medium, this system was very popular with the reporters.

For the athletic events, two cameras and 350 receivers were provided, while an additional two cameras and 100 receivers were installed for swimming and diving.

The main use for the equipment was quick reporting of the records of the events. When it was not being used for this purpose, however, the system was available for on the spot monitoring of events. (as for instance in the covering of the complete relay of the marathon race, which coverage was tried for the first time at the Tokyo Olympic Games.) This system therefore proved to be a very useful and acceptable adjunct to the overall news reporting facilities during the Tokyo Games.

Scenes like this could be found any day in the overseas press section of the stands



The Application of the IBM Electronic Computing System

In an effort to perfect the reporting and recording of the many details of the sports events and the entries (both national and individual), the Press and Public Information Division made use of an electronic computing system in cooperation with IBM.

The responsibility assigned to IBM covered the overall management of the sports recording; the production of national and individual entry statements; the immediate reporting of results; service for the teleprinter network; editing of the Olympic Games records, and other relevant details.

The 20 games entailed the use of 32 venues with the National Stadium as the main venue and the other venues in and around the Tokyo area and with some at a greater distance, (such as Karuizawa 150km from Tokyo, Lake Sagami 50km from Tokyo and Enoshima 50km from Tokyo) The collecting and transmitting of results over such a wide area made the use of a normal electronic computer impractical. It became necessary to provide a data managing device connecting the widely scattered venues to the data-processing centre, and to devise a system for transmitting and receiving the great volume of data at high speed and editing and printing these and where necessary transmitting this to each relevant site.

Tokyo Olympic Teleprocessing System

In order to perfect the requirements demanded for the Tokyo Games, a specific time computer was required. IBM had carried out careful research and designed a system which it named the IBM Tokyo Olympic Tele-processing System. This System was one organically linked by telephone wires, and consisted of large and small 8 sets of electronic computing systems, some 50 sets of recently developed data transmitting devices and 14 sets of high speed printing devices. An electronic data-processing system was situated on the first floor of the Press Centre adjacent to the National Stadium.

Organization of the Electronic Computing System

As a central computer was 2 sets of 140 type electronic computer systems (corememory 160,000 figures) provided with 2 sets of 1301 type magnetic disk memory devices (memory ability 56,000,000 figures per set). As auxiliary computers, 2 sets of 1440 type electronic computer systems (corememory 16,000 figures) was linked to 4 orders of multiplexbuffer computer (1448-1440) respectively, and to the buffer computer was provided 2 sets of 1311 type magnetic disk memory devices.

Some 50 sets of data transmitting devices were placed at the over 30 venues and these were directly

Data Centre Facilities

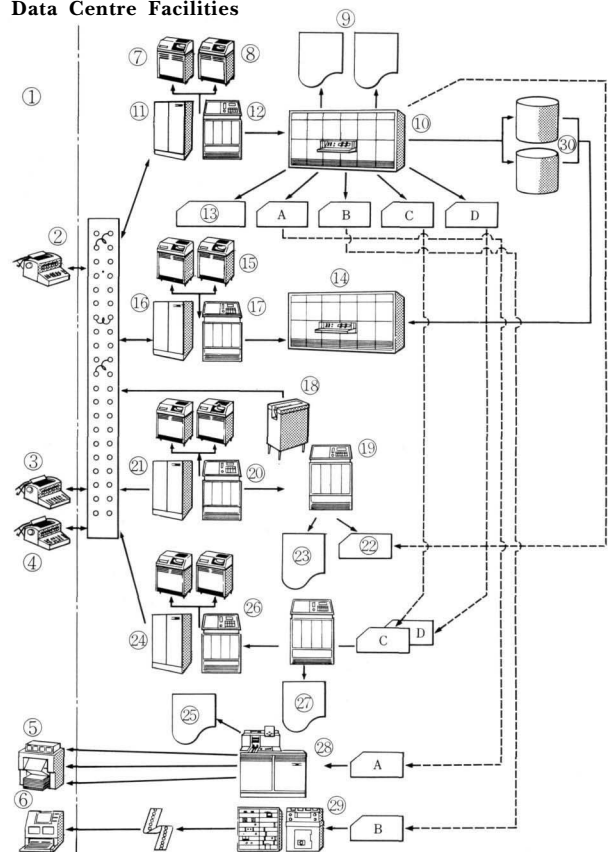

- | | |
|---|--|
| 1. Sports Venue | 16. 1448 type Transmission Controller |
| 2. 1052 type Printer Key Board (10 units) | 17. 1440 type Data-Processing System |
| 3. 1052 type Printer Key Board (29 units) | 18. 1056 type Card Reading System (2 units) |
| 4. 1052 type Printer Key Board (15 units) | 19. 1440 type Data-Processing System |
| 5. 1443 type Printing Machine (12 units) | 20. 1440 type Data-Processing System |
| 6. Teletype | 21. 1448 type Transmission Controller |
| 7,8 1311 Memory Units | 22. Original Card |
| 9. Record Sheets / Reports | 23. Original Memory Unit |
| 10. 1410 type Data-Processing System | 24. 1448 type Transmission Controller |
| 11. 1448 type Transmission Controller | 25. 1443 type Printing Machine |
| 12. 1440 type Data-Processing System | 26. 1440 type Data Processing System |
| 13. Original Card | 27. Report |
| 14. 1410 type Data-Processing System | 28. 1013 type Card Transmission System |
| 15. 1311 type Memory Units | 29. 063 type Card Reading Equipment for Teletype |
| | 30. 1301 type Disk Files |

connected with the electronic computer system at the IBM Data Centre. In addition, 14 sets of 1443 type printing devices were placed at the main venues by connecting with 1013 type card transmitting devices.

Athletics, swimming, rowing, shooting and similar events were restricted in the managing time of data, and there was a need of rewriting and combining course numbers or computing scores and these were then transmitted immediately back to the venues. The 1050 type, data-processing system was first connected to the 1448-144-1410 units. The 1050 type to be used at the other venues were connected to 1448-1440-1410 of the second order. Immediately after each event, the record papers were transmitted from sports operating officials to the 1050 IBM operator, and the operator changed these to the

previously determined code and typed by 1050 type date communication system.

Even when series of different data was transmitted from many 1050 type's to 1448 electronic transmission control system at the same time, these were controlled by programmers connected to the 1440 electronic computer system and systematically transmitted to 1440 and arranged in connect order. The data transmitted into 1440 was first for connection translated to show back number and match codes of names of athletes and events, and the code together with its translation were sent back to 1050 at the venue.

In this manner the operators and officials of the 1050 unit could confirm whether the data was correct. The examination was carried out by putting the names of athletes, country, participating order, course allotment etc. into the 1311 type magnetic disk memory device to check them with the transmitted data.

The examined data were transmitted, in case of the first and second orders, to 1410, and in case of the third order, to the 1440 electronic computer

system, respectively.

The sports records transmitted into 1401 were controlled by various data, i.e. athletes, country, matching, score counting, total score, results of individual or team within 1301 type magnetic disk memory device connected to an electronic computer system, and edited in a prompt report type, then punched into the card. There were four types of these prompt report cards with the following characteristics:—

Type A: This covered the detailed reporting and as the results of a preliminary match, the results of each match and the summary of that day were included. This was transmitted to the 1443 type printing devices installed at National Stadium, the main venues, Olympic Villages and Broadcasting Centre, and then printed by means of the 1013 card transmission device.

Type B: This was for the tele-type report, in which at the same time with A card, though the contents were more simplified, and is formed in

Diagram of Data-Processing System

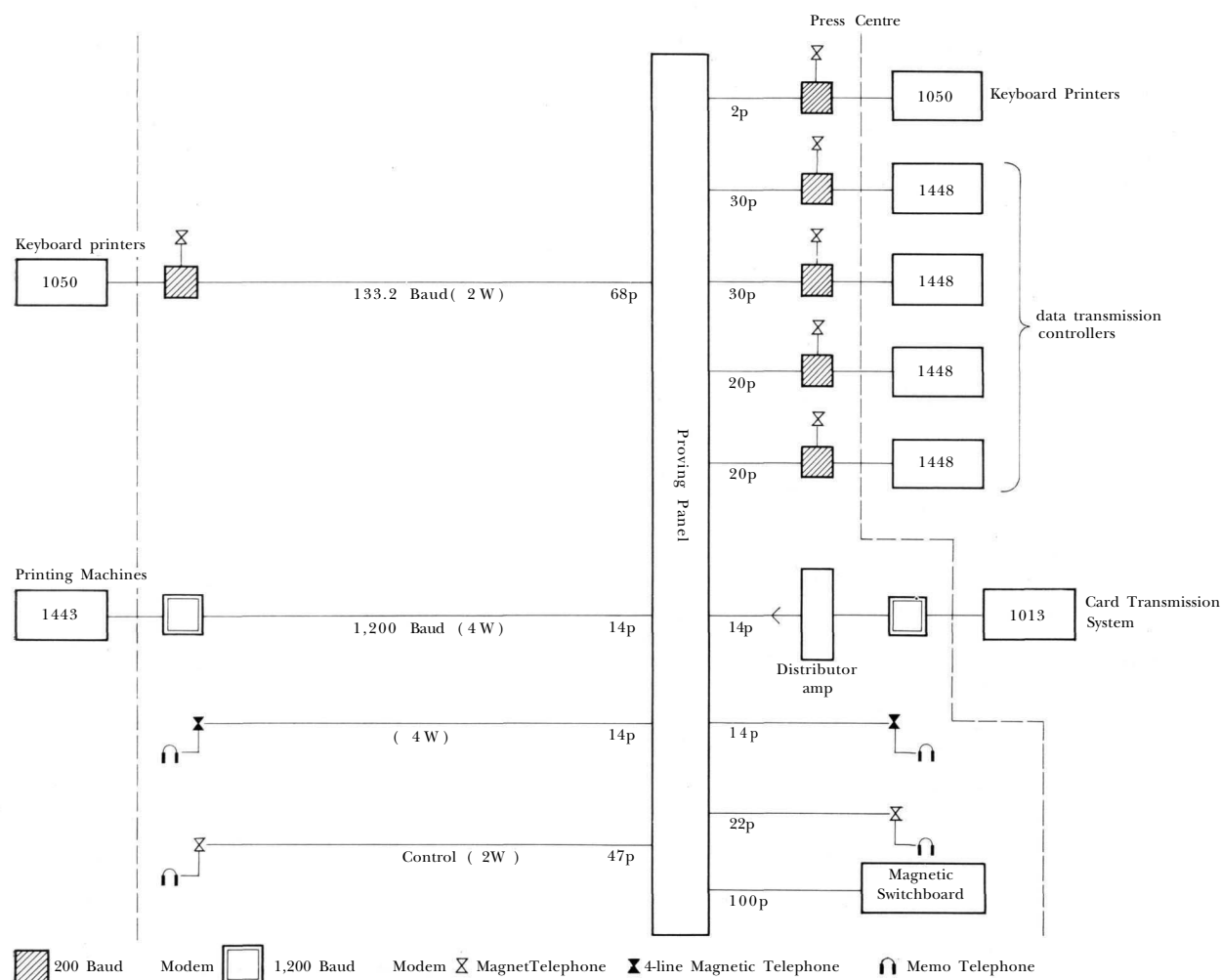

principle of 65 letters per figure to meet a tele-type printing mechanism. The cards were placed in 6 sets of 063 type paper tape punching device and changed to tele-type paper tape of 5 units. With this system, data transmitted from venues were managed by the electronic computer system and immediately transmitted to the International press companies and national major newspaper offices by wire.

Type C: For the venues without 1443 type printing devices, 1052 type printer keyboards were used as printers, by which summary reports were formed for each game, read by a card reading device of the forth order in figures, and transmitted to venues.

Type D: The venues without 1443 machines received detailed reports by similar systems.

Type E: This was prepared for athletics and swimming events, in which as soon as data were sent from venues to the electronic computer system, the report immediately sent back to the venue—what was know as a flash—for this reason 1050 data communication system was used, the electronic computer system was not only score computing in accordance with pre-set rules, and report producing, but also

in case of athletics and rowing, selecting athletes which were eligible to participate in the following races, from the preliminary events results, and in case of wrestling, eliminating the athletes from a line by reason of the number of bad marks, and making a new matching.

Service of Press Workroom

Here were provided 180 sets of typewriters at pressmen's workroom in the press centre, and typewriters were also reserved for the participating newsmen at National Stadium, Indoor Swimming Pool (swimming, diving), Komazawa Gymnasium (wrestling), sub-press centre and workroom in the broadcasting centre, respectively. The total number of typewriters exceeded 800 sets. These were of a number of types and providing 24 kinds of keyboards in English, French, German, Spanish, Russian and other languages. This equipment and necessary personnels was prepared in cooperation with Olivetti Japan, Ltd.

Application of Teletype

The games results arranged and transmitted by the IBM electronic computer system were printed



Data were transferred by data printers like these, to the printers in the Press Centre (right)





A whole view of the Press workroom, prepared in cooperation with Olivetti Japan, Ltd. in the main Press Centre. Here were provided 160 sets of the typewriters with 25 different languages

by offset Ricoh printers and immediately distributed to the press concerned at Press Centre and each game site. In addition the results were transmitted from the IBM Data Centre to each international press represented, the major overseas press Tokyo temporary offices, as well as the editorial offices of the major national press by teleprinters provided by the International Telegraph and Telephone Corporation.

Cooperation of Ricoh Printer

The IBM electronic computer system prepared lists of participants and registration lists by sports in a very short time, and the records at each game site were also arranged simultaneously and transmitted. These lists and records were printed by printers provided in the printing room in Press Centre and at each game site and Olympic Villages, and immediately distributed to newsmen, officials and athletes. The offset printer used for this printing and personnels therefore was carried out with the cooperation of Ricoh Co., Ltd.

Positioning of Teleprinters for receiving records of events

Company	Position	Equipment		Maintainer
		PP	KTRP	
AP	National Stadium AP Room	3		AP
UPI	National Stadium UPI Room	3		Toyo Printing
Reuters	Press Centre Reuters Room	3	1	Tokyo Denshin
AFP	National Stadium AFP Room	3	3	Nihon Tele-service
IOPP	National Stadium next to AP, PIX Room	3		Toyo Printing
TASS	Press Centre TASS Room	3		Tokyo Denshin
SID	National Stadium SID Room	3	3	Shinko Service
DPA	National Stadium DPA Room	3		Shinko Service
NBC	Sanko Daiichi Bldg.	3		Shinko Service
CORA	Press Centre AP Room	3	3	Toyo Printing
Asahi Newspaper	Asahi Newspaper Bldg.	3		Toyo Printing
Mainichi Newspaper	Mainichi Newspaper Bldg.	3		Mainichi
Yomiuri Newspaper	Yomiuri Newspaper Bldg.	3		Shinko Service
Sankei Newspaper	Sankei Newspaper Bldg.	3		Toyo Printing
Jiji Press	Jiji Press Editors Bureau	3		Tokyo Denshin
NHK	NHK Int'l Div.	3		Shinko Service
NET TV	NET	3		Shinko Service
Tokyo Channel 12 TV	Tokyo Channel 12	3		Toyo Printing
Chunichi Newspaper	Chunichi Newspaper Editors Bureau	3		Tokyo Denshin
OOE Equipment Total		57	10	

PP: Page Printer KTRP: Transmission Tape



The reports received from the IBM units reproduced speedily at this Ricoh Data Printing Centre

Equipment used for speed printing of sports events results

Station	No. used	No. reserve	Total	Printer personnel	Assistant	Printing copies
National Stadium	10	1	11	11	4	1,784,090
Tokyo Metropolitan Gymnasium	3	2	5	4	2	155,500
Prince Chichibu Memorial Football Field	1	1	2	1		16,000
National Gymnasium	7	2	9	13	2	1,047,800
Shibuya Public Hall	1	1	2	1	1	16,000
Komazawa Gymnasium	7	2	9	12	2	764,000
Equestrian Park	1	1	2	2		1,500
Karuizawa Equestrian Events Ground	1	1	2	1		13,000
Waseda Memorial Hall	1	1	2	3	3	104,000
Korakuen Ice Palace	1	1	2	3		147,000
Hachioji Velodrome	1	1	2	2		30,000
Asaka Shooting Range	1	1	2	2		20,000
Tokorozawa Clay Shooting Range	1	1	2	2		7,000
Toda Rowing Course	1	1	2	1		36,000
Enoshima Yacht Harbour	1	1	2	2		48,000
Lake Sagami	1	1	2	2		21,000
Mitsuzawa Football Field	1	1	2	1		20,000
Omiya Football Field	1	1	2	1		16,000
Yokohama Cultural Gymnasium	1	1	2	2		30,000
Nippon Budokan Hall	1	1	2	1		25,000
Tokyo Univ. Kemigawa Playing Grounds	1	1	2	1		1,500
Press Centre	13	1	14	23	8	5,688,500
Olympic Village	7	1	8	12	2	2,424,000
Broadcasting Centre	8	2	10	14	2	2,239,000
Total	72	28	100	117	24	14,654,890



The world's press representatives could monitor the fine points of the events by closed circuit television



Identifying arm bands issued by the Press and Publicity Division



The detailed results of all events listed in the four volumes issued at the close of the Games

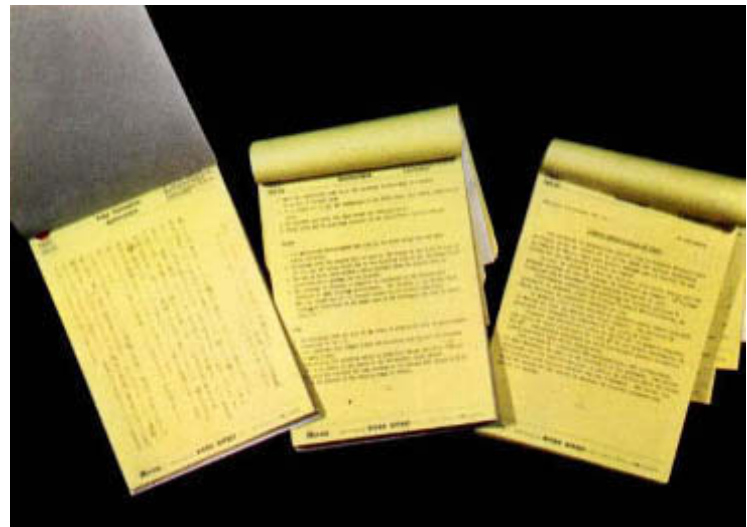

Press Releases



NHK (Japan Broadcasting Corporation)
Broadcasting Centre

Television camera in operation
during the Opening Ceremony



—and during athletic events



Antenna used for contacting SYNCOM III

Relay antenna



SYNCOM III

The direct transmission of television by means of a communication satellite was a mark of progress in Olympic Broadcasts, adopted for the first time during the Tokyo Games. This method enabled viewers in many parts of the world to see the events much sooner than by conventional methods

The receiving antenna in USA (Point Magoo)

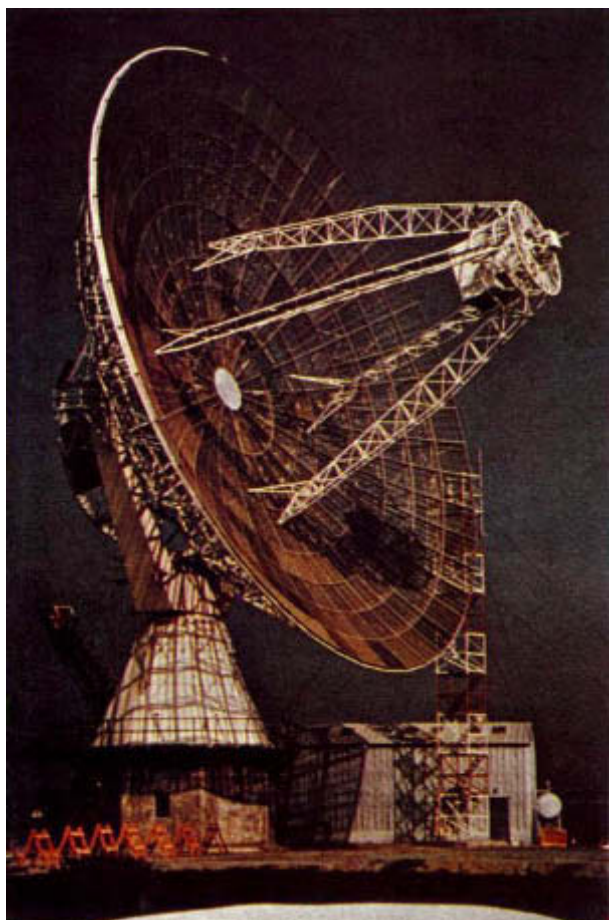



NHK used a television camera mounted in a helicopter (above) to cover the progress of the exciting marathon event, and a companion equipment truck which followed on the ground (below)



RADIO AND TELEVISION BROADCASTING

The radio and television broadcasting of the Tokyo Olympic Games was entrusted to the Japan Broadcasting Corporation (NHK), the public broadcasting system in Japan. This Corporation extended its full facilities to the Organizing Committee, placing not only its installations, but also personnel at the service of the Games organization. This cooperation was extended to all the private commercial broadcasting stations, who in turn formed a joint committee with NHK for this purpose.

With this wide coverage, NHK exerted its efforts to give as complete a coverage as possible to the Japanese public, and at the same time relayed broadcasts of up to eight events a day to broadcasting organizations overseas. A new page in coverage of Olympic Games was made by using a space satellite to relay pictures overseas. It was this simultaneous broadcasting of events in Tokyo which helped to make these Tokyo Games a occasion of even greater participation by the nations of the world.

Preparations

In April 1961, NHK was entrusted with a survey of the desires of broadcasting organizations overseas concerning the facilities at the time of the Olympic Games, and to conduct preliminary negotiations for telecast contracts.

On its part, NHK began its own preparations by setting up a Tokyo Olympic Broadcasting Headquarters and conducting negotiations with foreign countries. In October 1963, one year before the Olympic Games in Japan, the Tokyo International Sports Week was held under the joint auspices of the Organizing Committee for the Tokyo Games, the Japanese Olympic Committee, and NHK. This was in effect a rehearsal of the Tokyo Olympic Games. As one of the sponsors of the Tokyo International Sports Week, NHK mobilized 660 members of its broadcasting staff, and supplied material for radio and television programmes by relaying fifteen events out of the twenty, to some twenty-nine broadcasting organizations in twenty-four countries abroad. In January 1964, NHK set up its General Headquarters for Olympic Broadcasting and began its final preparations for the Tokyo Games. NHK was entrusted by the Organizing Committee with the supply of material for programmes to broadcasting organizations both at home and abroad. Apart from those working in local domestic stations, the staff mobilized for this purpose by NHK for

broadcasting and technical management totalled 1,965, which number included 114 radio newsmen, 90 cameramen, 195 producers, and 42 announcers.

The training of the personnel for broadcasting and technical matters was begun in May 1963. To each group was allotted a specific sport from the twenty involved, and intensive training was conducted to ensure an expert knowledge and ability, by means of on-the-spot training in the stadium concerned, as well as by classes. The practical training was given on twenty-four occasions between May and September 1963, and a further thirty-two times in 1964 between January until immediately before the Games.

Interpreters (in English, French, German and Spanish) were on duty at each stadium to facilitate the work of personnel from foreign broadcasting organizations who wished to gather material. For this purpose, 99 staff-members and 44 temporary employees underwent rigorous language training courses.

Broadcasting Rights and Contracts

Under the Olympic Charter, the rights to report the Games immediately on television are sold by the Organizing Committee. The rights to broadcast by radio are given free of charge to any broadcasting organizations who so state their desire. As was the case with Melbourne and Rome Games, where the necessary measures for broadcasting were entrusted to the Australian and the Italian Broadcasting Corporations respectively, the Organizing Committee entrusted the representative broadcasting corporation in Japan with the broadcasting of the Olympic Games.

The initial survey which NHK carried out in 1961, as did also the later enquiry, disclosed a strong interest in TV broadcasting by foreign organizations.

The Organizing Committee accordingly decided in September 1963 to entrust NHK with the entire responsibility for matters regarding the broadcasting of the Olympic Games, and an agreement to this effect was concluded between the two parties, and included the following conditions:—

- (1) NHK would install and manage the necessary equipment for radio and television broadcasting of all the events (including the Opening and the Closing Ceremonies) of the Tokyo Olympic Games.
- (2) The Organizing Committee would vest NHK with the entire right to live television cover-

age (including broadcasting by transcription), under Article 49 of the Olympic Charter, in consideration of a payment by NHK to the Organizing Committee of 568 million yen (US\$1,577,778).

(3) NHK would be entitled, in consultation with the Organizing Committee, to re-delegate these rights to other broadcasting organizations where this was deemed desirable.

The contracts made between NHK and other broadcasting organizations included clauses embodying the principles that:—

(1) The contracting television organization would be entitled to televise within the country concerned. These rights, however, would not be transferred or disposed of to a third party without the prior permission of NHK.

(2) The total broadcasting hours would be therein defined.

(3) The necessary installations and services would be managed in accordance with the "Television Technical Rules" drawn up by NHK, and any exceptions thereto would be specifically enumerated in the contract.

(4) The contracted price for the broadcasting rights, or programmes to be supplied by NHK would be defined.

No special contracts for radio broadcasting were concluded, and it was decided to afford facilities to broadcasting organizations abroad within the framework of the "Radio Technical Rules" which were drawn up by NHK.

Domestic private broadcasting To enable maximum coverage of the Olympic events with optimum efficiency, a "Tokyo Olympic Broadcasting Committee" was set up, in July 1963, and this comprised eight members from NHK and the domestic private commercial broadcasting companies. It was decided by that Committee that television would be carried out directly by NHK, and the other broadcasting companies would use for their own programmes the pictures which were funneled into the NHK Broadcasting Centre, the nucleus of the Olympic broadcasting. Each broadcasting agency then televised its own selection of images, accompanied by its own announcers' commentary.

For radio broadcasting, a detailed agreement was reached in September 1964 on the method of independent coverage of the Games by NHK and the private broadcasting companies.

Broadcasting organizations in Okinawa In October 1964, contracts were made with the Okinawa

Television, Radio Okinawa, and the Ryukyu Broadcasting Companies to transmit television and radio broadcasts of NHK simultaneously.

Broadcasting organizations abroad Contracts for television broadcasts included those with EBU (the European Broadcasting Union), NBC (the National Broadcasting Company), CBC (the Canadian Broadcasting Corporation), ABC (the Australian Broadcasting Commission), OIRT, and NBC International.

- a. EBU: A contract was concluded in November 1963 with this union of the broadcasting organizations of West European countries, and the rights to broadcast in eighteen West European television organizations, (including Great Britain, France, Germany, Italy, and others), were vested in EBU. The contracted broadcasting hours were twenty-five hours.
- b. NBC: The contract was signed in October 1963 with NBC of the United States, providing for twenty-five hours.
- c. CBC: The contract for the rights to broadcast in Canada was formally signed in January 1964 and provided for eight hours.
- d. ABC: For Australia and New Zealand contracts were signed in September 1963, for a total of twenty hours broadcasting.
- e. OIRT: By a contract made in August 1964 with OIRT, representing the broadcasting organizations of the East European countries. These rights covered the telecasting for twenty-five hours within the Soviet Union, East Germany, and the East European countries.
- f. NBCI: In February 1964, NBCI was entrusted with the negotiating of broadcasting rights to organizations in Latin America and Africa and the distribution of material for programmes, on the condition that images would be supplied by NHK for twenty-five hours to each organization. Thus twelve broadcasting organizations in twelve countries were supplied with images through NBCI.

Film programmes for Asian countries For the television broadcasting organizations in the Asian countries, a film of about thirty minutes duration daily and covering the "Highlights" of the sports was broadcast daily by NHK for home viewers during the Olympic Games, and this film was offered at cost to eight broadcasting organizations covering Asia.

Film summaries In May 1964, the Organizing Committee entrusted NHK with the production and distribution of film summaries as defined in Rule

49 of the Olympic Charter. Cameramen of the private broadcasting organizations also took part in this production, and two film summaries, (for use at home and abroad), were produced and supplied to broadcasting organizations on request.

Programming

National broadcasting programmes were arranged on the principle that, in view of the great domestic interest in the Olympic Games, broadcasting should provide as wide a coverage as possible and while maintaining this detailed coverage of events, the overall image of the Tokyo Olympic Games should be upheld with suitable programmes. Inasmuch as NHK was the only agency officially collecting television material, it made arrangements for cooperation with other broadcasting organizations, both domestic and foreign, to ensure the closest co-ordination in their planning and selection of material. In addition to the Opening and the Closing Ceremonies, sixteen out of the twenty different sports were relayed immediately both by radio and television, viz:— athletics, rowing, basket-ball, boxing, cycling, fencing, football, gymnastics, weight-lifting, field hockey, judo, wrestling, swimming and diving, equestrian sports, volley-ball, and water-polo. The other four sports were recorded by means of films or tape. The centre for the co-ordination of radio

Domestic Television Broadcasting hours during Games

Date	Broadcasting time				Total	
	Actual events		Olympic Highlights			
Oct. 10	2hrs. 50 min.		1 hr. 45 min.		4hrs. 35 min.	
11	11	52	1	00	12	52
12	10	18	1	15	11	33
13	10	25	1	15	11	40
14	10	37	1	15	11	52
15	10	18	1	15	11	33
16	10	13	1	15	11	28
17	10	13	1	00	11	13
18	11	03	1	00	12	03
19	12	03	1	15	13	18
20	10	23	1	15	11	38
21	10	03	1	15	11	18
22	9	58	1	15	11	13
23	11	29	1	15	12	44
24	4	35	1	30	6	05
Total	146	20	18	45	165	05
Average time per day	9	45	1	15	11	00

In addition to the above, 2 hours of Olympic Highlights were broadcast on 25th, October.

Table showing Television Broadcasting by sports

Event	10/10	11	12	13	14	15	16	17	18	19	20	21	22	23	24	
Opening Ceremony	●															
Athletics					○	○	○	○	○	○	○	○	○			
Football		○	○	○		○										
Basket-Ball		○	○	○			○		○		○	○	○	○		
Boxing		○	○	○		○	○	○		○	○	○	○		○	
Cycling							○	○		○			○			
Fencing					○	○	○	○			○		○	○		
Rowing					○	○			○		○					●
Gymnastics										●	●	○	○	●	●	
Weight-Lifting		●	●	○	○				○							
Hockey		○		●		○				○				○	○	
Judo												●	●	○	○	
Wrestling		○	○	○	●		●	●	○	○						
Swimming & Diving		○	○	○	○	○	○	○	○							
Equestrian Sports														○	○	●
Volley-Ball		○	○		○	●		○	○	○				○	○	
Water-Polo			○	○												
Closing Ceremony																○
		1	8	8	8	8	9	8	8	9	8	8	5	8	9	2

○ indicates both events of shift system ○ indicates ordinary TV broadcasting ● indicates colour televising

and television broadcasts set up within the Broadcasting Centre, coordinated with its broadcasting facilities and network throughout the various sports venues to ensure an efficient overall programming.

Television broadcasting During the Olympic Games, some eight sports were shown on television, three times a day (in the morning, afternoon, and at night). "Highlights" and other programmes were also produced. The actual Olympic broadcasting incorporated a number of techniques. Actual sport scenes were broadcast by the relay system in a previously planned order, and in some cases, relays of interesting scenes from any stadia or fields were inserted by means of the multi-synchronous-lock equipment which had recently been developed. Plural broadcasts were used, and other such special effects as video transcription, slow-motion videos, electronic records, etc., were efficiently employed. Slow-motion videos were popular particulars with overseas broadcasting organizations.

For the marathon race, NHK employed its full resources and covered the race by means of a newly designed mobile relay van equipped with a vibration-proof device. Twenty-six television cameras were set up in the National Stadium, while along the route, helicopters, and UHF antenna direction control equipment were used. Thus, for the first time in the history of Olympic broadcasting, a complete live relay of the entire marathon course was realized, making a fitting highlight to the Tokyo Games. The studio of the National Stadium was equipped for the convenience of overseas broadcasting organizations with a video monitor, and guiding announcements were broadcast in English, to enable announcers of other countries to follow the actual action as it occurred.

Colour television was broadcast on the day of the Opening Ceremony, and on most other days one

Radio Broadcasting Times (domestic) during Games

Date	Broadcasting time				Total	
	Actual events		Olympic Highlights			
Oct. 10	2 hrs. 30 min.		1 hr. 45 min.		3hrs. 15 min.	
11	11	37	1	09	12	46
12	10	10	1	09	11	19
13	9	10	1	09	10	19
14	10	10	1	09	11	19
15	9	22	1	09	10	31
16	10	13	1	10	11	23
17	10	02	1	04	11	06
18	9	57	1	09	11	06
19	9	10	1	09	10	19
20	9	39	1	09	10	48
21	8	50	1	09	9	59
22	9	25	1	09	10	34
23	10	45	1	10	11	55
24	2	13	2	04	4	17
Total	133	13	17	43	150	56
Average time per day	8	53	1	11	10	04

In addition, 54 min. of highlights were broadcast on 25th, October.

of the sports was broadcast in colour. Eight sports (gymnastics, judo, weight-lifting, hockey, wrestling, volley-ball, football, and equestrian sports) were televised in colour for over 16 hours in all or an average of more than two hours a day.

Radio As has been outlined, the radio coverage like that of television was carefully worked out and provided on a complete and continuous basis throughout the Games.

In the marathon race, the whole course was relayed with fixed microphones at seven points along the route. In the mobile relaying van were technicians both from NHK and also from private broadcasting companies.

News items contained relays from sports events, instant reporting of the results, impressions, and topics, etc. to supplement the actual line coverage of the events.

Broadcasting of the Exhibition of Fine Arts

NHK covered also the Exhibition of Fine Arts which was held under the provisions of the Olympic Charter concurrent with the Olympic Games. Television broadcasts were also made of the displays as well as the theatrical, musical, and other performances. Actual broadcasting details can be seen from the charts in this section. Much attention was attached to the publicity of this Exhibition inasmuch as this was considered an important function

of the Tokyo Olympic Games.

Domestic Private Broadcasting

Television "The Olympic Broadcasting Committee" was set up in July 1963 by representatives of NHK and the Japan Private Broadcasting Federation for the purpose of achieving the most efficient broadcasting of these Olympic events. In February 1964, it had been arranged that NHK alone would produce television pictures but that these would be made available for all broadcasting organizations for their individual programmes. Images were supplied to the Private Broadcasting Federation on a booking system for seven or eight events a day, or for an overall total of 93 times for 383 hours. The Private Broadcasting Federation broadcast its own announcers' comments on the Opening and the Closing Ceremonies, as well as the eight sports of athletics, boxing, gymnastics, judo, wrestling, swimming, volley-ball, and weight-lifting, and relayed the announcements of NHK for the eight other sports of rowing, basketball, cycling, water-polo, football, field hockey, fencing, and equestrian sports. In cases where the broadcasting hours of NHK did not coincide with those of the Private Broadcasting Federation, NHK extended its cooperation by providing special an-

Domestic Radio Broadcasting Time by events

Events	TV	Radio
	hrs. min.	hrs. min.
Athletics	49 15 (8)	57 40
Rowing	15 30 (4)	18 00
Basket-Ball	9 00 (5)	36 50
Boxing	51 03 (10)	68 40
Cycling	11 45 (4)	27 00
Fencing	25 20 (7)	25 10
Football	8 00 (4)	13 20
Gymnastics	36 15 (6)	51 40
Weight-Lifting	20 00 (5)	56 40
Hockey	6 52 (5)	16 55
Judo	16 30 (4)	18 51
Wrestling	53 45 (8)	44 40
Swimming & Diving	45 35 (8)	29 50
Equestrian Sports	11 30 (3)	—
Volley-Ball	18 30 (9)	50 00
Water-Polo	1 10 (1)	14 30
Modern Pentathlon	—	2 00
Yachting	—	4 00
Shooting	—	4 00
Canoeing	—	2 00

nouncements at the broadcasting hours of the Federation.

Radio For radio, the equipment provided by NHK was used, and the material obtained at each venue was summarized before broadcasting. Broadcasts were relayed from the stadium to the respective companies via the Broadcasting Centre, and further relayed to the nation-wide networks to which those companies were connected. Nineteen events, (all except the equestrian events), were relayed to the Private Broadcasting Federation for a total of 541 hours, excluding the Opening and the Closing Ceremonies.

Foreign Broadcasting Organizations

NHK as holding the worldwide rights to television coverage of the Tokyo Games, was entrusted with the function of arranging and coordinating the radio and television installations.

The Booking Office The Booking Office carried out a variety of functions including the following:—

- a. Allocation of radio and television broadcasting seats, and delivery of admission tickets therefore.
- b. Allocation of radio and television studios.
- c. Supply and allocation of images for video tape and other transcriptions.
- d. Allocation of seats to 16mm cinecamera-men and delivery of admission tickets therefore.
- e. Reception of requests for film interviews.
- f. Allocation of studios in the Olympic Village.
- g. Issuing of relevant admission passes into the Olympic Village.
- h. Allocation of the sound transmission lines between the venues and the Broadcasting Centre.
- i. Allocation of the PTS (the programme transmission service).
- j. Delivery of film summaries.
- k. Delivery of film programmes for Asian broadcasting.
 1. Issuing of shoulder-type sound recorders.
- m. Delivery of stickers, specific assignment arm bands, etc.
- n. Delivery of the relevant Identification Cards.
- o. Service for the purchase of transcription tapes.
- p. Administration and management of the overseas broadcasting equipment in the venues and the Broadcasting Centre.
- q. Distribution of interpreters for the areas under NHK supervision.
- r. Provision of general information.

Activity of overseas broadcasting organizations

A total of 656 cameramen and radio broadcasters were assigned by overseas broadcasting organizations, including nineteen from television organizations and fifty-five for radio from forty countries. Kenya, Pakistan, Monaco, and others dispatched one man each, while EBU sent a large team of 280 persons.

A breakdown of the personnel assigned by foreign broadcasting organizations is given in a separate table in this section.

The overseas broadcasting organizations which concluded contracts for television broadcasting with NHK, and relayed the Tokyo Olympic Games are also listed separately herein.

EBU; NBC; NBCI; CBC; ABC; OIRT

NHK supplied these six overseas broadcasting organizations with direct telecasts for eight events a day (nine events on 15th, 18th and 23rd October). On the days when no events were relayed by NHK from a particular venue, cameramen were allowed to take 16mm films.

These video images were broadcast in forty-five countries of the world. If the supply of film summaries, referred to later, and film programmes for Asian broadcasts, are taken into account, the events of the Tokyo Olympic Games were in fact covered by 104 broadcasting organizations, other than Japan

Overseas Broadcasting Organizations Broadcasting

Country	Organization	TV	Radio	Personnel
Belgium	BRT, RTB	○	○	9
Denmark	DSR	○	○	8
Finland	YLE	○	○	17
France	RTF	○	○	18
Germany (West)	ARD, ZDF	○	○	37
		○		20
Israel	Kol Yisrael		○	1
Italy	RAI	○	○	21
Luxemburg	CLT		○	5
Monaco	RMC		○	1
Netherlands	NRU	○	○	17
Norway	NRK	○	○	12
Sweden	SRT	○	○	17
Switzerland	SSR		○	11
Great Britain	BBC, ITA	○		52
		○		21
France	Europe No. 1, OCORA		○	6
			○	1
U.S.A.	NBC, ABC	○	○	72
			○	13

and Okinawa. This was indeed the greatest coverage in the history of Olympic broadcasting.

Transcription The six broadcasting organizations were enabled, by virtue of their contracts with NHK, freely to select and transcribe any sports relayed by NHK, which, in compliance with requests made by the broadcasting organizations, supplied them with images on 365 occasions for a total of 1,313 hours. Slow motion VTR, a recent development, was broadcast on 135 occasions covering eight events, including athletics and swimming, boxing, judo, and equestrian sports. On 130 occasions images were supplied to the overseas broadcasting organizations and the domestic private broadcasting companies.

EBU: EBU took part in the publicity of the Olympic Games by despatching personnel from twelve broadcasting organizations of ten countries. It was necessary in view of its composition, for EBU to transcribe comments in ten different languages. Except for the Opening and the Closing Ceremonies, Athletics and several of the other events, therefore, EBU used the off-tube method, (this is, by using guiding commentators at the actual venue and listening in to their coverage in the studio, and then aided by the TV monitor, to record a commentary in the respective languages). In the Olympic Broadcasting Centre four to six events a day were recorded, and images were supplied 67 times for 204 hours. From such material EBU produced programmes for air-freighting to Europe, and a one-hour programme for relaying through space.

NBC: NBC covered from seven to nine events a day. NHK supplied it with images 74 times for 320 hours, from which material, NBC produced and broadcast a programme from fifteen to sixty minutes a day. It relayed the Opening Ceremony to the United States through space via Syncom III.

NBCI: From four to five events a day were covered by NBCI, to which NHK supplied images 51 times for 93 hours. Programmes were broadcast mainly to Latin America with commentaries in Spanish and Portuguese.

CBC: From four to five events a day were transcribed with comments in English and French. Two programmes in English and French for thirty minutes a day were produced from the material supplied 54 times for 296 hours, and relayed through space to Canada. Programmes were sent also by air.

ABC: From four to five events a day were supplied on a total of 49 occasions for 164 hours. ABC compiled its own transcriptions and sent the tapes by air.

OIRT: OIRT had a contract which allowed it

to receive in Europe the EBU broadcasts and broadcast the images with a video tape recorder. In Tokyo, therefore, OIRT added guiding comments in German and Russian by the off-tube method to the images transcribed by EBU. In addition, with the kineoscope, OIRT covered the events not recorded by EBU. By these two methods OIRT covered from four to eight events a day, and NHK supplied images 79 times for 233 hours, including 46 times for 102 hours by the kineoscope.

In order to supply the coverage required by all these different outlets, it was necessary for NHK staff to completely televise almost all events from the beginning to the end during the Tokyo Olympic Games, to feed the monitors in the Broadcasting Centre.

Filming by Foreign Broadcasting Organizations

The broadcasting organizations which had contracted with NHK for broadcasting were permitted to take 16mm films at any venue at times when the event was not actually being relayed by NHK. By booking, therefore, thirty cameramen of five broadcasting organizations, not including CBC, covered several sports on 92 occasions. These additional coverages were mainly of field hockey, yachting, football, and equestrian sports events.

Radio The radio broadcasting experts sent to Japan by fifty-five overseas broadcasting organizations, covered from three to five sports events a day. Their methods were as follows:

- a. Live relaying (broadcasting from the venue or the studio direct to the home country)
- b. Recording (recording via the studio, or at the venue)

Live television was relayed from the venue direct to the respective countries by the PTS, such as the Pacific submarine cable, via forty studios in the Broadcasting Centre. Thirty-five broadcasting organizations covered the events mainly by recording live relays, and nineteen others transmitted recorded material to their own countries by the PTS. Four broadcasting organizations from Uruguay, Kenya, Brazil, and Nigeria sent their transcribed tapes by air.

During the Olympic Games a total of 10,422 hours of coverage was provided, including 910 hours for live relays and 7,578 hours for recording (being 1,976 hours for recording relayed to the studios, and 5,611 hours for simultaneous). Much time was given for the live relaying of athletics and swimming, (for which 207 and 179 hours were used respectively), and of boxing, basket-ball, and football. BBC (UK), RAI (Italy), and RTF (France)

and other network broadcasts live relaying consumed 1,372 hours for Athletic broadcasting, and 1,186 hours for swimming. Boxing, cycling, wrestling, and rowing followed in that order. In recording hours, the main organizations involved were ARD (West Germany, 430 hours), BBC (336 hours), and CBC and the National Broadcasting Committee of Soviet Union (331 hours each).

The thorough preparation which NHK had arranged eliminated any trouble in the complex arrangement for domestic and overseas broadcasting. A broken Pacific cable used by foreign broadcasting organizations for transmission to their home countries, however, made a temporary interruption. On the night of 15th October, a cable break occurred east of Guam and this was not repaired until 21st October. As a result, cable transmission to North and South America and Europe except for the Soviet Union became impossible. The KDD Co., Ltd., switched over to microwave services, though these did not prove to be as satisfactory as the cable.

Film summaries By an agreement of May 1964, the Organizing Committee entrusted NHK with the production and distribution of film summaries, as provided for in the Olympic Charter. By co-operation between NHK and the private broadcasting companies, fifty cameramen were mobilized for the collection of material, and two editions, domestic and overseas, including the Opening and the Closing Ceremonies and all the main events of each day, were produced, and distributed, upon request, to broadcasting organizations and news agencies.

The overseas edition was for broadcasting for fifteen minutes each day with a commentary in English, and this was distributed the following morning. Forty-two rolls were sent out to forty-two broadcasting organizations (including four news agencies). The film summary was broadcast to eighty-eight broadcasting organizations in sixty-five countries, including those supplied by news agencies.

In making these film summaries, forty-nine arri-flex cameras were used to take a total of 220,000 feet of film in fifteen days, or on an average 15,000 feet a day. For the parade of the participants at the time of the Opening Ceremony, in particular, additional summaries were provided and distributed. The requests for these were mainly for the coverage of the parade of the participants of that particular country. The address by IOC President Avery Brundage, and His Majesty The Emperor of Japan's declaration of the opening of the Games of the XVIII Olympiad were distributed among the broadcasting organizations by magnetic single films. Similarly distributed were the Olympic "Anthem", the Olympic march, and the fanfare of

trumpets recorded on magnetic tapes.

Film Programmes for Asia

For the reason that the rights to broadcast the television of the Olympic Games were expensive, the broadcasting organizations of the Asian countries were, in some cases, not in a financial position to apply for relay transcriptions. In view of the fact, however, that the Tokyo Olympic Games were the first such occasion to be held in Asia, and that an Asian Broadcasting Federation had been inaugurated, NHK decided to produce a special programme for supply to the broadcasting organizations of the Asian countries. From the "Olympic Highlight" (a summary of the day's events) of the NHK nightly domestic programmes, certain sports were selected for a 30-minute broadcast, and printed for distribution at cost among the Asian broadcasting organizations. These programmes were supplied to the following organizations:—

- Taiwan Television Enterprise
- Singapore National Broadcasting
- Malaysian Television
- Bolino Electronics (the Philippines)
- Radio Mindanao
- Korean Information Bureau
- Cairo National Broadcasting (the United Arab Republic)

Programme for Okinawa

A contract was concluded early October 1964, between NHK and the Okinawa Television, the Radio Okinawa, and the Ryukyu Broadcasting, the three broadcasting organizations in Okinawa, to transmit TV and radio programme of the Olympic Games. For television, the microwave system which had been initiated between the mainland and Okinawa towards the end of August was used, and for the radio the existing sound transmission line was made use of for simultaneous relaying.

During the Olympic Games, TV programmes were supplied for 156 hours 9 minutes to the Okinawa Television and 148 hours 2 minutes to the Ryukyu Broadcasting. Radio programming was sent for 148 hours 36 minutes to the Radio Okinawa and 129 hours 59 minutes to the Ryukyu Broadcasting.

Other Facilities

A number of auxiliary facilities were offered for the benefit of technicians and other personnel concerned with Olympic Games broadcasts, both domestic and overseas. These facilities included an information centre, distribution of IBM flashes, customs clearance facilities for film and tape, and overseas telephone, telex services, etc.

Broadcasting Facilities

The overall fundamental plan for the broadcasting facilities was drawn up after careful consideration of the experiences at the time of the Olympic Games in Melbourne and Rome, and on the basis of the replies to the questionnaires sent to broadcasting organizations abroad, as well as the schedules of the games decided by the Olympic Organizing Committee. For TV in particular, the experience of the Rome Olympic Games was most helpful.

The facilities and services were offered to outside organizations in accordance with the "Radio Technical Rules" and the "TV Technical Rules", which had been drawn up for the Games of the XVIII Olympiad. The Broadcasting Centre at Yoyogi functioned as a unified centre of the radio and TV broadcasting, where all the sounds and images from the venues were collected.

Sound relays between the venues and the Broadcasting Centre, and those between the NHK Hall and the International Telephone and Telegraph Corporation were all carried by wire. Images were however, transmitted by the national microwave system from the venues direct to the Broadcasting Centre, and partly to the transmission centres via the Tokyo Tower and the NHK Hall. Coaxial cables were laid for the National Stadium, in consideration of its being the main sports venue, and for the National Gymnasium, its Annex, and the Shibuya Public Hall, because of their geographical proximity to the Olympic Broadcasting Centre.

The Olympic Broadcasting Centre was a seven-storied building with a floor space of 65,000 square meters situated at Jinnan-cho, Shibuya-ku, Tokyo. It provided not only six TV studios and forty-four radio studios, but also a sound switching centre fed by all the sound transmission lines from the venues, and these were connected at this centre where required. The Broadcasting Centre housed also the TV workrooms which were the heart of the TV broadcasting.

The sound monitoring centre All the sound transmission lines from more than thirty venues and the Olympic Village (approximately 1,600 radio and TV transmission lines) were connected with the respective workrooms via this monitoring centre. Most of the lines were connected with the workrooms after being switched by a giant cross-bar switchboard installed in this centre.

Facilities for domestic radio broadcasting Four radio studios were provided, and the production studio was connected with fifteen venues by transmission lines. Live relays and broadcasting of

transcriptions, including plural broadcasting, were carried out.

Broadcasting facilities for overseas radio broadcasters Forty provisional radio studios were set up and allotted equally to the overseas broadcasting organizations, each studio was connected with the venues by four sound transmission lines, and with the KDD Co., Ltd., by one transmission line. Each was equipped with one sound mixing amplifier, two tape recorders, an auxiliary tape recorder for editing, a telephone set, to facilitate the planning and broadcasting of programmes by live relaying (including plural broadcasting), relaying, sound recording, and processing.

Facilities for domestic TV broadcasting The NHK broadcasting facilities included TV operation rooms, TV editing studios, TV news studios, rooms for VTR film control, special picture effects, VTR, and transcription. Except for the studios and the VTR rooms, all these facilities were used also for services overseas. A special hall was provided for colour telecasts.

TV operation facilities The images and sound received through the cable lines from the venues were distributed, both to the NHK equipment for home use by simultaneously switching both lines, and to overseas and the Private Broadcasting Federation via the film processing control room. For this latter, some eight events daily were directly distributed. Of the five TV studios, one was for news, another for production, and three for VTR film control. The production studio was the largest of its kind, it being required to serve for the production of plural broadcasting relay programmes as well as marathon relays. In addition to the facilities for the outside systems (five systems of marathon and five other venues), input installations for the reproduction of VTR, slow-motion video reproduction, special picture effects, the FSS (flying spot scanner), and the time indicating devices for marathon, and vidicon were provided. As transcription facilities for domestic use, ten VTR's and two kineoscope recorders were set up. Moreover, twenty-three VTR's (including reserves) and six kineoscope recorders were provided to serve for transcription for overseas broadcasting organizations. Considerable weight was given to the slow-motion VTR, which was at that time still a recent development. Two slow-motion VTR's and apparatus to shoot single choice scenes, and electronic recording apparatus were provided, and signals for the special effects were distributed for use on both home and overseas transmission.

TV overseas broadcasting facilities To overseas broadcasting organizations, NHK, under contract, provided control rooms, TV studios, VTR rooms, off-tube rooms, offices, and film editing rooms.

Venues

In the thirty-two venues for twenty sports, broadcasters' seats with name plates were arranged by the Organizing Committee and NHK. Exceptions were the Enoshima Yacht Harbour, the Asaka Shooting Range, the Asaka Nezu Park for modern pentathlon, and the Kemigawa Playing Grounds of Tokyo University. The number of seats for both the radio and TV was approximately 600. In each seat was installed relaying apparatus connected with the Broadcasting Centre via the mixer room. The broadcaster's seats in most of the venues were in the main stand. The standard width of the broadcaster's seat was 1.1m for two persons. The depth was 1.5 times that of the spectator's seat, or from 1.2m to 1.3m. The seat was equipped with microphones necessary for on-the-spot broadcasting, a telephone, and head-phone, etc. A TV monitor was also installed in the TV broadcaster's seat. (In the National Stadium, the TV monitor was installed also in the radio broadcaster's seats, so that the scenes near the goals could be seen as clearly as those actually at that position). In principle, close-talking microphones were used for announcements. Ideally the mixer seat should have been set up together with the broadcaster's seat. To have done this however, would have seriously diminished the number of spectator's seats. As in the Olympic Games in Rome, therefore, the mixer room was arranged in an area where they did not interfere with spectator seating. The distance between the broadcaster's seats and the mixer room was approximately 30m to 80m. In addition, eighteen small rooms behind the broadcaster's seats in the National Stadium were used for tape editing. Studios were set up not only in the venues, but also in the Olympic Village, and each studio was arranged for both radio and TV. For TV relays, fixed cameras were installed in approximately 100 seats at the venues of sixteen sports. During the Games, thirteen TV relay vans necessary for the transmission of eight events a day and videos from the studios of the Olympic Village were stationed at the venues concerned. Together with eight TV relay vans, eight VTR vans were also stationed as microwave reserves to record the scenes. Power supply cars were generally sent to the venues and attached to the relay vans. At the National Stadium, two TV control rooms were arranged on the first floor of the main stand near the goal, and equipment for two black-and-white relay vans (in-

cluding eight cameras) was installed in the rooms. One set of the apparatus was used for track events and the other for field events.

Newly Developed Equipment

In an effort to achieve the greatest possible effect in the Games broadcasting, NHK gave particular emphasis to the development of new apparatus, and thus a number of new devices, viz.:—the "multi-synchronous-lock equipment," the "close-talking microphone," the "slow-motion VTR equipment," the "auto-homing antenna for helicopters," and the "1/2-inch vidicon camera," were used. This equipment gave NHK's broadcasting arrangements wider scope and mutually helped in achieving the excellent coverage effected.

Space Relaying

For the first time in Olympic history space relaying was successfully utilized in telecasting. This success was largely due to the close cooperation between the U.S.A. and Japanese technical experts, and proved to be a significant factor in the brilliant achievements of broadcasting facilities on that occasion. The space relaying was agreed upon on 23rd July 1964 by a contract concluded between NHK and COMSAT (the Communication Satellite Corporation) of the United States and involved the use of Syncom III, the stationary satellite.

Syncom III Space Relay Network

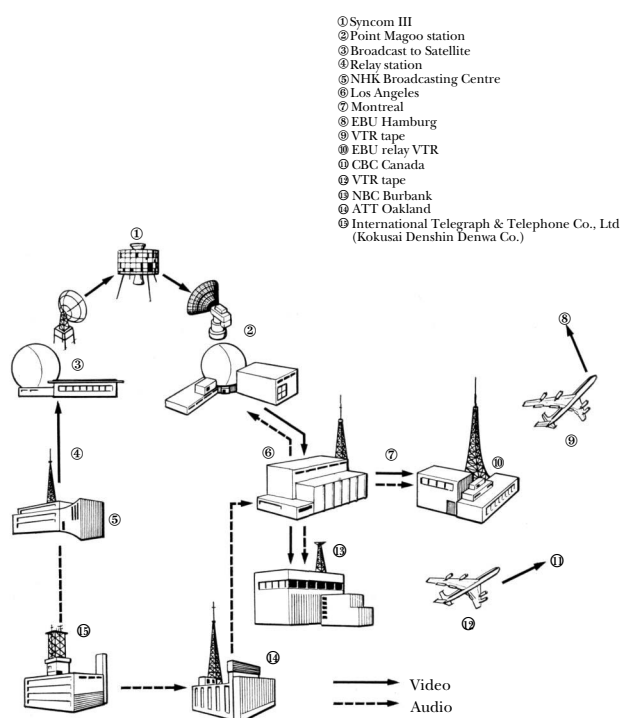

Similar contracts were concluded by COMSAT with RCA (the Radio Corporation of America), and also with EBU. As a result, the actual scenes of the Tokyo Games were televised via Syncom III to more than twenty countries of the United States, Canada, and Europe.

Broadcasting during the Games to the United States by this method totalled 5 hours 41 minutes 11 seconds, 12 hours 27 minutes 4 seconds, or 30 to 60 minutes a day between 9 p.m. to EBU, and 14 hours 18 minutes 30 seconds between 9 p.m. and 11 p.m. each day to CBC. The East European countries received images from EBU.

Pictures were received by space relaying in the United States, Canada, and in the following twenty-one countries in Europe:

France, Great Britain, Belgium, Netherlands, Luxemburg, West Germany, Italy, Switzerland, Sweden, Norway, Denmark, Finland, Spain, Portugal, Austria, Eire, Poland, Yugoslavia, East Germany, Czechoslovakia, and Hungary.

The lengths of the broadcasting time to the three main broadcasting organizations during the Olympic Games are given in the following table.

Broadcasting time via relay Satellite

Date	EBU		CBC		USA Network		
	min.	sec.	min.	sec.	hrs.	min.	sec.
Oct. 10	57	00	59	00	1	54	10
11	28	40	57	33			
12	25	28	57	40	14		(Test)
13	27	49	57	50	15		(Test)
14	32	50	57	38	15		
15	37	04	54	23	16		
16	58	35	53	06	15		
17	59	27	58	06	24		
18	62	30	58	08	15		27
19	59	56	58	12	17		
20	63	40	58	10	16		10
21	60	11	58	59	16		37
22	60	16	58	13	15		49
23	59	05	53	20	15		20
34	54	33	58	12	16		55
25							14 43
Total	12. 27. 04.	14. 18. 30.	5. 41. 11.				
	hrs. min. sec.	hrs. min. sec.	hrs. min. sec.				
Overall total		32 hrs. 26 min. 45 sec.					

Monitoring broadcasts at NHK



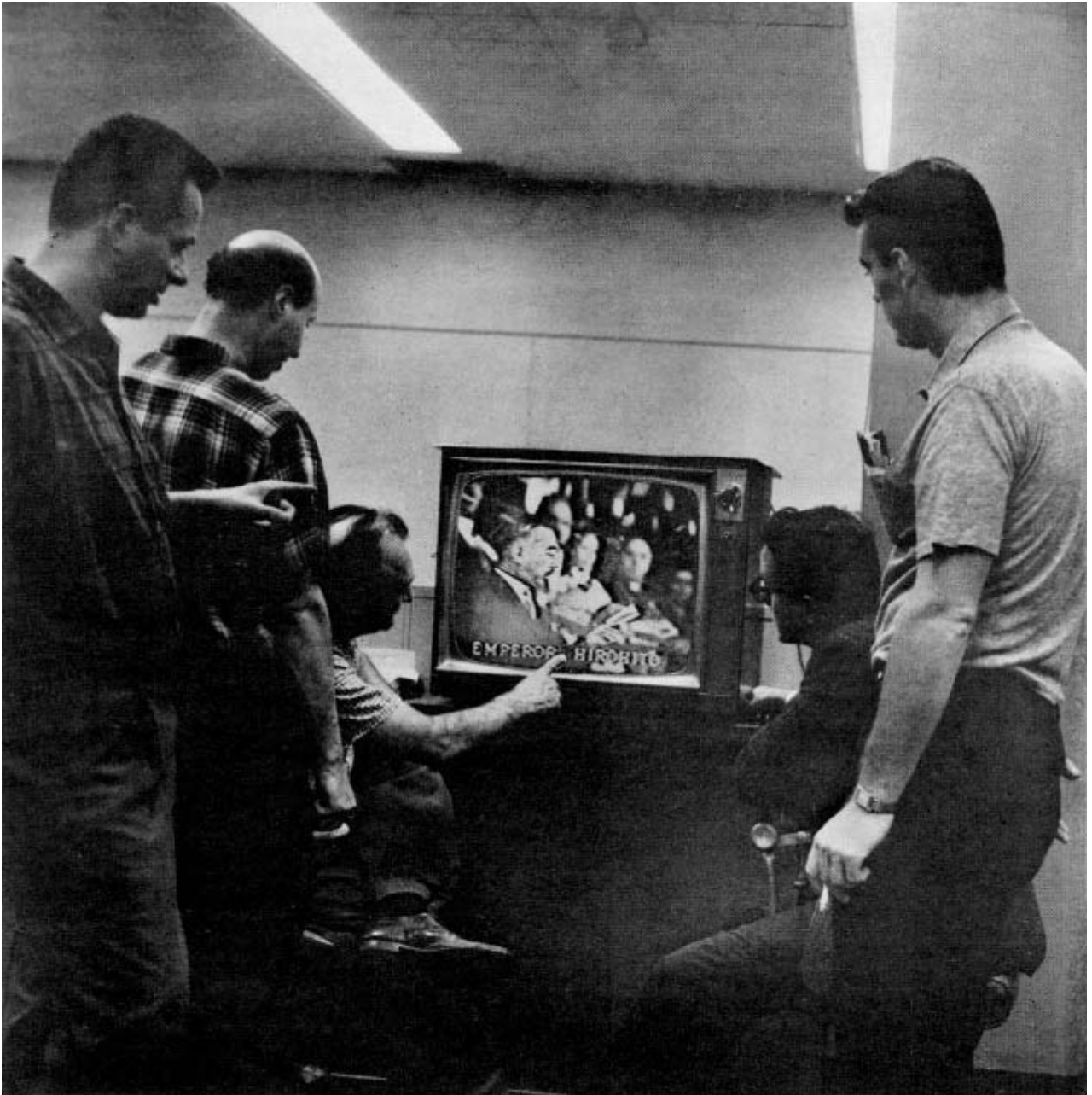

H.M. The Emperor declaring open the Games as viewed on the TV Screen in New York after being relayed by Space Satellite

The experience of broadcasting of the Games has shown how important is the pre-planning and envisaging of all problems likely to arise. It was this careful planning that enabled this most complex system of broadcasting to be so harmoniously achieved, allowing a great number of persons throughout the world to see and hear almost immediately the events of this first Olympic Games to be held in Asia.

Antenna for relaying signals to and from the Space Satellite

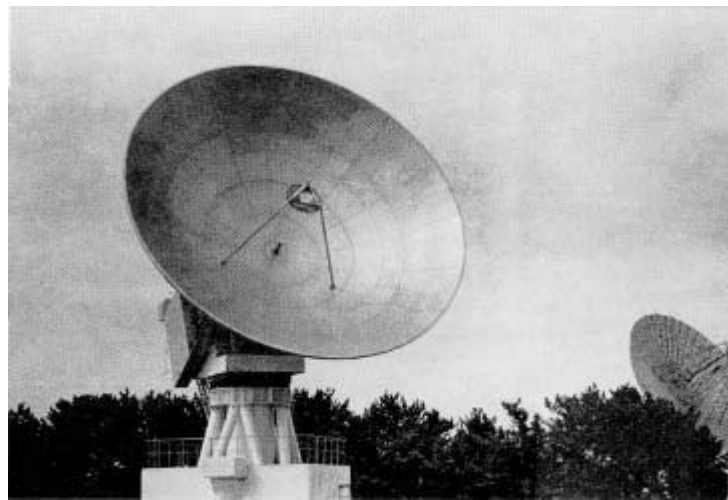

COMMUNICATIONS

Communication Service in Tokyo

The efficient management of the Olympic Games required the ability to maintain easy communication between the various Olympic facilities and organizations, and adequate means for news agencies and other news media of the various countries to promptly transmit their Olympic reports and sports records to their overseas headquarters. Fully mindful of these needs, preparations were undertaken by the relevant organizations well in advance of the Games.

All the domestic telegraph and telephone services in Japan are under the control of the Nippon Telegraph and Telephone Public Corporation (NTT). As of October 1964, the number of telephone subscribers in Tokyo was 1,300,000 and the actual number of telephones totalled 1,980,000. Domestic demands for telephones continue to increase and it has now become necessary to make plans for the installation locally of some 200,000 additional telephones each year. It was no easy task, therefore, to adequately meet the communica-

Route of Pacific Cable

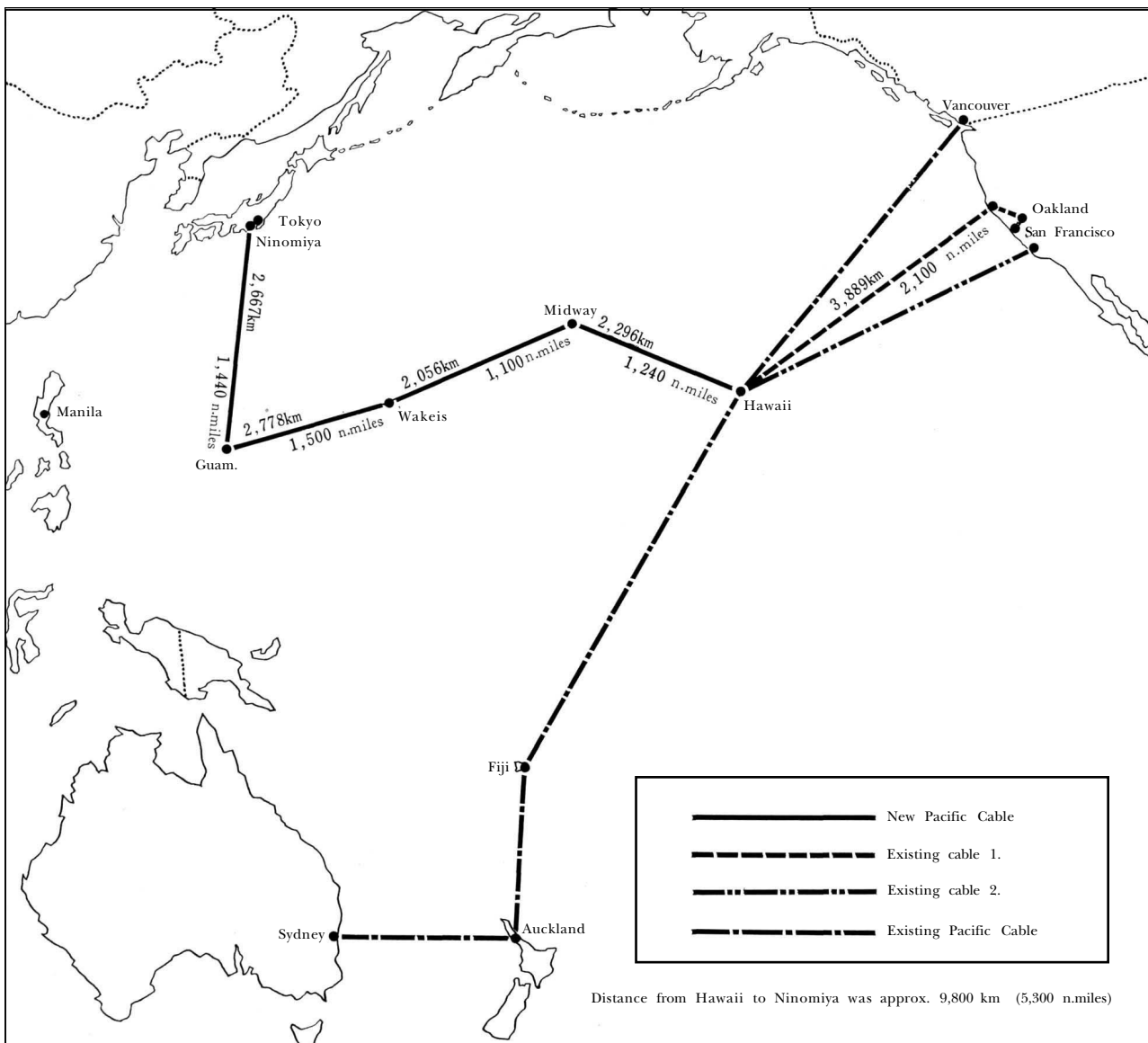

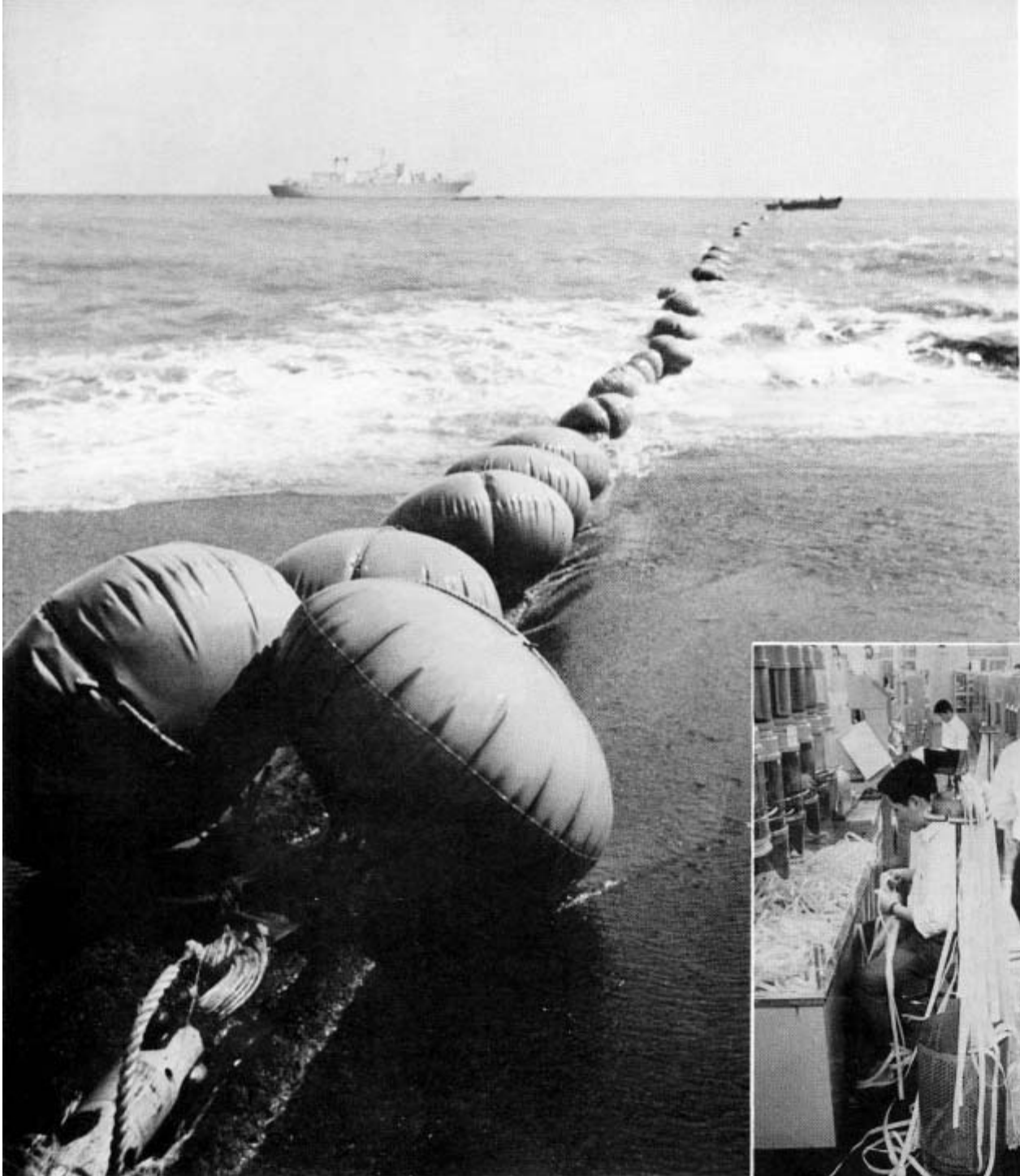

The laying of the new pacific cable which materially assisted communications during the Tokyo Games

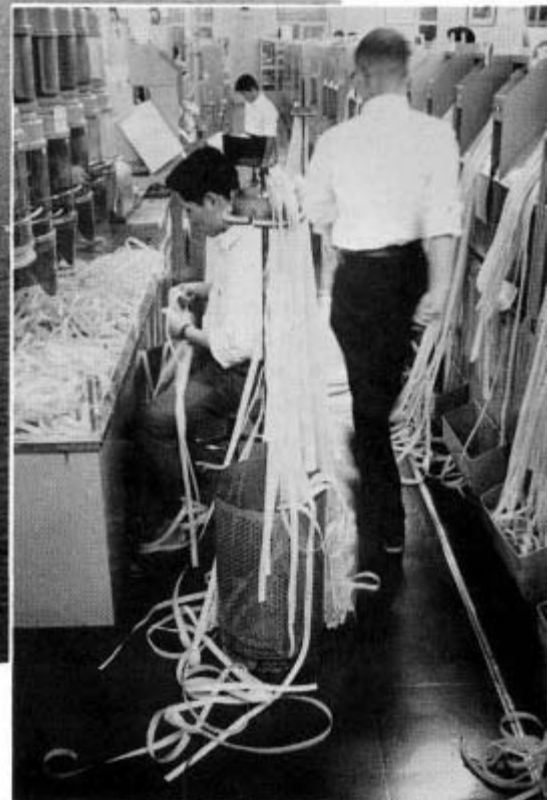

tions requirements of the Tokyo Olympic Games which by their nature, called for concentrated functions of telecommunications in certain areas over a short period of time. The NTT conducted a demand survey twice, first in September 1962 and later in June 1963. On the basis of their findings they proceeded with the construction of the required telephone exchanges and the expansion of communication facilities and cable relays to connect the Olympic Villages and Games sites. Dial systems connecting Tokyo with the other areas where Games were held were installed to permit direct dialing. This work proceeded in order of this pre-planning, and by September 1963 the network was ready to cope with the pressure that

would be required of it.

Overseas telegraph and telephone services in Japan are the monopoly of the Japan Overseas Radio and Cable System (KDD), and until recently most of the communications between Japan and foreign countries were conducted by shortwave for reasons of Japan's geographical situation. Short-wave communications however, have only a limited circuit capacity and suffer from quality defects. To alleviate these conditions, the US Telephone and Telegraph Corporation, the Hawaii Telephone Co., the Japanese Ministry of Postal Services and the KDD had several years before the Games, embarked on the project of laying a transpacific coaxial cable between Japan and the United States,

and this cable was completed in June 1964. This connection resulted in greatly improved quality and capacity of communications not only between Japan and the United States, but also between Japan and the countries of Europe, by connecting that cable to the existing cable between the United States and Europe. The completion of this transpacific cable in time for the Games proved to be an important factor in the international news coverage of the Tokyo Olympic Games.

Preparation of Communication Services

In view of the important role which communications assumed in the management of the Olympic Games, the Organizing Committee set up, within the Special Facility Committee, a Telecommunication Subcommittee made up of representatives of the Ministry of Postal Services, the NTT, KDD, the Japan Broadcasting Corporation and other related organizations, thus enabling the Organizing Committee to have the benefit of expert advice and coordination in proceeding with its preparations. Inasmuch as the various communication plans required specialized technical knowledge, the Facility Division of the Secretariat was assisted by two employees of the NTT in their basic communications facilities planning. The work of this section expanded as the Games drew near, necessitating the attachment of six additional specialists from NTT and one from KDD.

In January 1964, a Communication Section was set up within the Transportation and Communication Division of the Secretariat to take charge of the operation of communications facilities and other related work.

Actual Communication Facilities Used

Communication facilities made use of for the Olympic Games were installed in coordination with the overall planning of the Games, and in consideration of the estimated requirements for transportation of athletes and officials, administration of Games sites, traffic control and reporting activities, as well as the services for visitors and spectators. The overall communication network, which systematically connected the various Olympic facilities to the Headquarters, the Olympic Villages and Games sites, was planned and private branch-exchange telephones, direct dial telephones, leased lines and interphones were installed at points where they were considered to be most useful. Mobile communication equipment of the Self Defense Forces was made use of in providing communica-

tion services for some of the events.

Private branch exchange facilities Private branch-exchange telephones were used at 26 Olympic facilities. At 10 of these locations the Olympic Organizing Committee undertook expansion work of the existing equipment to provide for the additional requirements of the Olympics. At the remaining 16 places, the NTT newly installed temporary private branch-exchange telephones. Extension telephones were arranged in such a manner that a telephone was available for every three persons in each office, and that each room used for purposes other than as an office had at least one telephone. This arrangement was intended to ensure prompt and easy liaison between Olympic officials.

Also, to meet the expected increase in the volume of calls to and from outside organizations, switchboards capable of handling double the usual number of telephones were installed to achieve greater efficiency in telephone communications. These PBX telephones were operated by an automatic exchange where the number of extension sets exceeded 80, and by a Common Battery switchboard where that number was below 80.

In addition to this PBX equipment, leased-line exchanges were installed at 18 places to operate leased lines for use in conducting yacht races, in establishing liaison contracts for the transmission of sports records, in the management of Games sites, and for use in traffic control.

Direct dial telephones Direct dial telephones were made use of instead of installing PBX telephones, at those outdoor Games sites such as Asaka Nezu Park, Kemigawa Playing Grounds and Karuizawa Equestrian Park. With the direct dial telephones installed at the offices, training gymnasiums, parking lots, Olympic officials' quarters and Haneda Airport where the volume of calls was greater than at other places, the number of direct dial telephone circuits totalled 840. The installation of 71 direct dial telephone circuits at the Olympic Headquarters, in addition to the PBX extension telephones ensured efficient liaison even if the exchanges themselves were to become overloaded.

Leased lines Leased lines were installed to provide communication for emergency contacts or liaison between those Games sites requiring frequent use of telephones. Liaison was further facilitated by incorporating three systems of leased-line network, viz; one between Kishi Memorial Hall and each Games site, and second between the Olympic Villages and each Games site, and a third between transportation terminals such as the Transportation

Headquarters, Haneda Airport and officials' quarters. Besides these networks, a number of leased lines were installed to serve the additional pressure of calls expected during the opening and closing ceremonies, and to service the traffic police activities and to ensure effective control at Games sites. These leased lines were used extensively and were responsible for much of the efficiency in communication between widely separated points.

Interphones Interphones were used mainly for liaison between officials within the Games sites, in transmitting sports results and for assembling athletes. Four types of interphones were used according to their application, viz; two-way, master-slave, through-line and general-calling types. With the exception of the National Stadium and Yokohama Cultural Gymnasium where existing interphones were available, a total of 170 interphone sets were installed temporarily at all the other Games sites (See Table). These interphones actually proved most useful in providing easy contact between officials not only at the Games sites, but also between officials when similar events were being held simultaneously at different grounds as in the case of hockey played at the Komazawa Sports Park. Interphones were also made use of to advantage in transportation liaison (dispatching of vehicles, etc.) at the officials' quarters and Olympic Villages.

Public telephones The NTT installed a total of 595 public telephones in and around Olympic facilities for the benefit of spectators, athletes, officials and reporters. Eight telegraph and telephone service stations were set up to handle domestic and telephone services for spectators and reporters, and also station to service athletes and officials.

Operation and Use of Communications

Operation of PBX telephones More than 220 foreign language speaking telephone operators were required to man the telephone exchanges. The recruiting and training of this number of operators with language qualification was a problem of some magnitude. The Committee accordingly entrusted the Tokyo PBX Federation, a special organization designed to train telephone operators, with the task of selecting and training the operators as well as with the operation of telephone exchanges during the Olympic Games.

The Federation commenced its preparations in January 1964 under the guidance and cooperation

of the NTT, some 223 operators at that time being selected from 3,000 applicants for their fluency in English and general intellectual and cultural backgrounds, and were trained in exchange techniques and English conversation for four months from April and received actual practical experience for two months (August and September) at telephone exchanges of commercial companies in Tokyo. In this way, the training of telephone operators for the Olympic Games proceeded steadily and adequate preparations for handling telephone calls in English were completed. Telephone operators versed in French, Spanish and other foreign languages were assigned to the Olympic Villages and the Press House where calls in foreign languages other than English were expected in greater numbers, and as a result no inconvenience appeared to be felt by the athletes, officials and reporters, and the entire telephone exchanges operation during the Games proceeded in a most efficient manner.

Calls handled in foreign languages throughout the Games sites averaged some 12 percent of the total, and at the Press House, where more calls

Use of Telephones at Olympic Installations
(for the 15 day period of the Games)

Site	Tele-phones	Calls	Av. per day	Av. per day per telephone
National Stadium	310	149,072	9,938	32
Prince Chichibu Memorial Football Field	40	5,378	359	9
Tokyo Metropolitan Gymnasium	84	31,889	2,126	25
Tokyo Metropolitan Indoor Swimming Pool	46	14,124	942	20
Meiji Jingu Baseball Field Stadium	54	4,829	322	6
Press Centre	174	69,265	4,618	27
Press House	63	34,383	2,292	36
NHK Broadcasting Centre	132	128,295	8,553	65
National Gymnasium and Annex	133	76,441	5,096	38
Shibuya Public Hall	49	20,397	1,360	28
Main Olympic Village	239	215,759	14,384	60
IOC Headquarters	156	101,509	6,767	43
Transportation Centre	31	12,269	818	26
Komazawa Sports Park	243	79,466	5,298	22
Equestrian Park	59	18,761	1,251	21
Yokohama Cultural Gymnasium	55	14,703	980	19
Mitsuzawa Football Field	37	5,232	349	9
Enoshima Yacht Harbour	85	79,697	11,385	134
Oiso Detached Village	26	34,654	2,310	89
Hachioji Detached Village	221	107,634	7,176	32
Toda Rowing Course	85	24,989	2,272	27
Asaka Shooting Range	73	18,754	1,562	21
Tokorozawa Clay Shooting Range	42	11,544	770	18
Omiya Football Field	55	8,745	583	11
Tokyo University Kemi-gawa Playing Grounds	38	3,027	3,027	79
Karuizawa Equestrian Events Ground	141	74,520	6,775	48
Total	2,671	1,345,336	—	—



Special Telephone Directories issued for Olympic Games numbers

were handled in foreign languages, this percentage was nearer 48 percent. Telephone exchanges were operated for 24 hours a day at Olympic Villages, the Press Centre, Press House and Kishi Memorial Hall, while exchanges at the Games sites were operated from several hours before the Games and until one or two hours after the Games for that day had been completed.

Domestic telegrams The number of domestic telegrams to and from Olympic facilities totalled 32,000, some 5,000 of these being outgoing and 27,000 incoming. Almost one half of this total were concentrated at the Olympic Village. Telegrams addressed to athletes and officials were delivered to Olympic Villages as were congratulatory telegrams and those received after the close of the Games, even when they were addressed to Games sites, and in this way the message was delivered to the addressee without undue delay.

Use of overseas communications Overseas com-

munications were used mostly by foreign news agencies and other news media. The Japan Overseas Radio and Cable System (KDD) set up 26 temporary overseas telegraph and telephone service stations to handle the additional Olympic volume. These were in addition to the existing Tokyo, Nihonbashi, Shinbashi, Kyobashi and Yokohama overseas telegraph and telephone central stations. A Table shows the number of overseas cables and telephone calls handled during the Tokyo Games. This greatly exceeds the normal overseas communications volume by the following percentage: cables, 8%; telephone calls, 4%; telex, 8%; telegraphic broadcasts, 39%; telegraphic photo service, 360%; radiophotos, 250%.

Information centre On the basis of the experience gained during the Tokyo International Sports Week in 1963, it was expected that telephone exchanges would be flooded with enquiries from the general public during the Olympic Games to such an extent as to impede the official communications required for the Games. In fact, as the Games approached, the office of the Olympic Organizing Committee received an ever increasing number of requests for information over the telephone, and this to some extent, did begin to interrupt the office routine. To deal with this situation an information centre designed to provide information over the telephone was established in the former Akasaka Palace, to alleviate the necessity of Olympic officials having to handle calls of this nature.

The information centre initially operated with 10 circuits, but this was later expanded to 15 to cope with an even greater number of calls for information than had been expected. The centre handled approximately 100,000 telephone calls during the one month period from September 25 to October 24. Telephone facilities at Games sites were therefore fully utilized during the Olympic Games without being interrupted by calls for information.

Telephone directory Since telephones for the Olympic Games were temporarily installed and were not therefore listed in a regular directories, the NTT published Olympic telephone directories for the convenience of athletes, officials and foreign visitors. These directories listed in Japanese, English and French not only telephones directly connected with the Olympics themselves but also the numbers of foreign Embassies and Legations in Japan, hospitals, hotels, banks, airlines, shipping firms, taxi companies, department stores, and other useful numbers. 150,000 copies of these directories were printed and of these 20,000 copies were presented to the Olympic Organizing Committee. They were well received by athletes and officials,

who not only used them as telephone directories but also in most cases took them home as mementoes of the Olympics.

Aside from this publication, the Olympic Organizing Committee published special telephone books for the benefit of those actually concerned with the operation of the Games. These telephone books listed extension numbers of each exchange in addition to direct dial telephones. 6,000 copies of this directory were prepared in Japanese and 4,000 in English.

Communications for the press The task of providing the large number of newspaper reporters with sufficient telephone circuits to cover the Games and to also making available adequate overseas communications for foreign reporters was one of considerable magnitude. That facilities were so successfully received was due to the foreseeing planning of the Olympic Organizing Committee, the NTT and the Japan Overseas Radio and Cable System (KDD).

Overseas communications— The Japan Overseas Radio and Cable System (KDD) requested overseas communication agencies, through the Ministry of Postal Services, for firm communication commitments in order to estimate the overseas communication requirements at the time of the Olympic Games. KDD installed overseas communication circuits were installed on the basis of these estimates.

Temporary overseas communication circuits installed for the Games numbered 45 for telegraph and 29 for telephone, all of which were primarily for the use of foreign news agencies, newspaper companies and broadcasting corporations. The domestic circuits temporarily installed for overseas communication numbered 123 for telegraph, 211 for telephone and 30 for other applications.

To facilitate news coverage, the KDD set up temporary overseas telegram and telephone service stations at 19 sites including the Press Centre and sub-Press Centre. At 21:45 on 15th October, the sixth day of the Games, the Japan-US Transpacific coaxial cable was damaged between Guam and Hawaii. While locating the damage, the KDD immediately redirected circuits from that cable to radio, completing the changeover by 10:00 on the 16th. This incident produced no serious confusion in the communications. The damage in the meantime was located some 8 miles from Guam toward Hawaii and a cable-laying vessel was immediately dispatched to that area. The break was completely repaired six days later on 21st October, an exemplary time for an undersea cable repair of this nature.

Domestic communications:— It was extremely difficult to predict in early stages of preparations

International communications used during Tokyo Olympic Games

	Type of communication	Total number of operators handled		Remarks
		No. of time	Words or minutes	
International Telegrams	Newspapers Telegrams (handled by temporary offices)	2,144	590,001	(Planned 10,000)
	Ordinary Telegrams (handle by temporary offices)	17,031	407,168	
	Sub-total	19,175	997,169	
	Other telegraph offices	2,990	324,128	
	Total	22,165	1,321,297	
Telex	Handled by temporary offices	1,371	22,051 min.	(Planned 6,000)
	Others	20	350 min.	
	Total	1,391	22,401 min.	
Int'l communications		647	approx. 8,411 min.	(Planned 13,000 min.)
Int'l photo-telegrams		413		(Planned 600)
PTS	From Oct. 10 To Oct. 25	868	38,293	(Planned 75,000 min.)
Int'l exclusive use telegraph cables		23 cables	for America 3 cables for Europe 19 " for Australia 1 "	(Planned 22 cables)
Int'l exclusive use telephone cables		9	for America 2 cables for Europe 7 "	(Planned 10 cables)
Int'l telegraphic broadcasting		H. I SL AP SL AP MLA Reuters SE AFP SE AAP SY Mirror SY	6 companies, 4 directions, 81 hours in a day (1,944 hours for 24 days)	(Planned 125 hours in a day) (2,500 hours or 20 days)
Int'l photographic broadcasting		AFP SL AP SL AP MLA John Fair SY Mirros SY ANC SY H.W. SY TASS MCW *UPI *SF	8 companies, 5 directions (6 cables with exclusion of SF) 33.5 hours in a day (1,005 hours for 30 days)	(Planned 45 hours in a day) *not temporary cable, but existing cables
Int'l broadcasting NHK temporary schedule		Total number of hours 336		
Connected Equipment	for Exclusive use telegraph terminal	23x3=69		
	for Telegraphic broadcasting terminal	7X2=14		
	for Temporary telex	9X2=18		
	Int'l 5 units printer (OOC special use)	115	OOC use : 70 Other use : 45	
	Total	216		

Total number of communications handled covers period September 15 through October 25, 1964

the number of direct dial telephones and leased lines which would be required by news agencies and other news media for their news coverage, and the NTT installed a number of reserve circuits in the lead-in cable for the Press Centre and Games sites in anticipation of additional requirements of the circuits. Table below shows the number of direct dial telephones and leased lines used by news agencies and newspaper companies during the Tokyo

1. Number of subscribed telephones

Location	No. sub-subscribed	PBX		
		Office wire	Switch board	Ext. Telephone
National Stadium	111	16	3	49
Prince Chichibu Memorial Football Field	7			
Tokyo Metropolitan Gymnasium	26			
Tokyo Metropolitan Indoor Swimming Pool	13			
Meiji Jingu 2nd Baseball Field Stadium	6			
Press Centre	63	8	1	21
National Gymnasium	43			
National Gymnasium Annex	11			
Shibuya Public Hall	20			
Kishi Memorial Hall	4			
Main Olympic Village	22			
Komazawa Stadium	11			
Komazawa Gymnasium	27			
Komazawa 2nd Hockey Ground	9			
Komazawa Volley-Ball Court	24			
Komazawa 1st Hockey Ground	12			
Komazawa 3rd Hockey Ground	9			
Equestrian Park	15			
Nippon Budokan Hall	24			
Waseda Memorial Hall	14			
Korakuen Ice Palace	24			
Yokohama Cultural Gymnasium	22			
Mitsuzawa Football Field	10			
Enoshima Yacht Harbour	19			
Oiso Detached Village	1			
Lake Sagami	20			
Hachioji Velodrome	19			
Hachioji Cycling Road Race Course	19			
Koshu Highway	1			
Tokorozawa Clay Shooting Range	12			
Tokyo Univ. Kemigawa Playing Grounds	9			
Toda Rowing Course	24			
Omiya Football Field	10			
Asaka Shooting Range	16			
Asaka Nezu Park	6			
Karuizawa Equestrian Events Ground	12			
Press & Newspaper	242			
Others	6			
Total	913	24	4	70

Games. The use of these telephones and leased lines was concentrated at the Press Centre and the National Stadium which became the centre of reporting activities.

Inasmuch as the assignment of press seats at some of the Games sites was not completed until shortly before the Games were due to open, the responsible department of the NTT was faced with the task of installing a large number of telephones within a

2. Number of terminals equipped for the leased lines

Location	Unit	City		Outside the city		Total
		Telephone	Others	Telephone	Others	
National Stadium		103	76	17	1	197
Prince Chichibu Memorial Football Field		6				6
Tokyo Metropolitan Gymnasium		17				17
Tokyo Metropolitan Indoor Swimming Pool		6				6
Meiji Jingu 2nd Baseball Field Stadium		4				4
Press Centre		52	70			122
National Gymnasium		34				34
National Gymnasium Annex		6				6
Shibuya Public Hall		8				8
Kishi Memorial Hall		7				7
Main Olympic Village		2				2
Komazawa Stadium		4				4
Komazawa Gymnasium		15				15
Komazawa 2nd Hockey Ground		4				4
Komazawa Volley-Ball Court		10				10
Komazawa 1st Hockey Ground		5				5
Komazawa 3rd Hockey Ground		3				3
Equestrian Park		5				5
Nippon Budokan Hall		8				8
Waseda Memorial Hall		6				6
Korakuen Ice Palace		12				12
NHK Broadcasting Center		2	10			12
Yokohama Cultural Gymnasium		4		7		11
Mitsuzawa Football Field				3		3
Enoshima Yacht Harbour		2		8		10
Lake Sagami		4		10		14
Hachioji Velodrome				5		5
Hachioji Cycling Road Race Course				8		8
Koshu Highway				6		6
Tokorozawa Clay Shooting Range				7		7
Tokyo Univ. Kemigawa Playing Grounds				3		3
Toda Rowing Course		2		7		9
Omiya Football Field		2		5		7
Asaka Shooting Range				6		6
Asaka Nezu Park				3		3
Karuizawa Equestrian Events Ground		1		9		10
OOO concerned		2				2
Press & Newspaper		400	195	184	115	894
Police concerned		2				2
KDD		2	2			4
Others		1				1
Total		741	353	288	116	1,498

very short period of time, and this was completed only with the diligent efforts of all involved with this responsibility.

The NTT set up telegraph and telephone service stations for the exclusive use of reporters at the Press Centre and Komazawa Sports Park, and installed public or direct telephones near press seats at each Game site to assist in the speedy reporting of news.

Transmission of sports data The collection, processing and prompt reporting of records was greatly facilitated by the employment of an IDP data-processing system using IBM electronic computers at the Data Centre within the Press Centre. Fourteen 1200-baud and sixtyeight 200-baud circuits were used for transmission of data from input-output equipment at each Games site to the electronic computer system at the Data Centre. Fifteen

Location of telephones provided at Games sites

Location	Unit	Telephones at the Games Sites				Telephones for the Press				Public telephone	International telephone	Inter-phone	Total
		Sub-scribed	Leased lines	Ex-tension	Total	Sub-scribed	Leased lines	Ex-tension	Total				
National Stadium		35	223	192	450	93	404	49	546	70	49	—	1,115
Prince Chichibu Memorial Football Field		4	12	47	63	9	40	—	49	11	—	8	131
Tokyo Metropolitan Gymnasium		10	32	68	110	28	76	—	104	11	—	4	229
Tokyo Metropolitan Indoor Swimming Pool		5	5	35	45	15	45	—	60	7	—	2	114
Meiji Jingu Baseball Field Stadium		21	12	—	33	—	—	—	—	—	—	—	33
Meiji Jingu 2nd Baseball Field Stadium		2	4	—	6	6	5	—	11	—	18	—	35
Press Centre		28	150	87	265	64	146	21	231	10	49	—	555
Press House		4	—	468	472	—	—	—	—	5	2	—	479
National Gymnasium		16	55	103	174	45	143	—	188	26	10	3	401
National Gymnasium Annex		3	2	—	5	13	50	—	63	10	—	—	78
Shibuya Public Hall		7	18	54	79	22	54	—	76	5	—	15	175
Kishi Memorial Hall		62	15	286	363	5	11	—	16	1	—	—	380
Main Olympic Village		11	71	720	802	26	22	—	48	57	9	19	935
Komazawa Sports Park		54	127	184	365	102	235	—	337	79	9	39	829
Equestrian Park		11	27	74	112	16	36	—	52	7	2	5	178
Nippon Budokan Hall		7	22	65	94	26	63	—	89	23	—	20	226
Waseda Memorial Hall		8	24	70	102	16	51	—	67	6	1	10	186
Korakuen Ice Palace		5	20	44	69	26	87	—	113	6	3	20	211
Yokohama Cultural Gymnasium		21	12	55	88	24	55	—	79	10	2	—	179
Mitsuzawa Football Field		11	11	57	79	12	37	—	49	15	2	6	151
Enoshima Yacht Harbour		17	13	44	74	20	17	—	37	17	5	—	133
Oiso Detached Village		5	6	—	11	1	—	—	1	7	4	4	27
Lake Sagami Detached Village		10	115	60	185	—	—	—	—	2	3	4	194
Lake Sagami		4	70	—	74	21	28	—	49	15	2	—	140
Hachioji Detached Village		1	32	129	162	—	—	—	—	4	4	4	174
Hachioji Velodrome		15	18	—	33	21	116	—	137	13	—	—	183
Hachioji Cycling Road Race Course		47	173	—	220	21	64	—	85	25	4	3	337
Koshu Highway		2	61	—	63	1	32	—	33	26	—	—	122
Tokorozawa Clay Shooting Range		12	14	51	77	13	14	—	27	4	2	—	110
Tokyo Univ. Kemigawa Playing Grounds		20	11	—	31	9	10	—	19	5	—	—	55
Toda Rowing Course		24	35	79	138	27	65	—	92	14	4	—	248
Omiya Football Field		15	26	51	92	12	40	—	52	14	2	4	164
Asaka Shooting Range		11	24	40	75	17	13	—	30	5	2	—	112
Asaka Nezu Park		19	8	—	27	6	7	—	13	1	—	—	41
Karuizawa Detached Village		8	1	89	98	—	—	—	—	5	3	—	106
Karuizawa Equestrian Events Ground		25	12	—	37	12	10	—	22	6	3	—	68
Others		195	43	60	298	—	—	—	—	74	—	—	372
Total		755	1,504	3,212	5,471	729	1,976	70	2,775	596	194	170	9,206

1200-baud and one-hundred and seventyfive 200-baud demodulators were used, all of which were designed and manufactured under the direction of the NTT. Fortyseven two-wire voice circuits were used for liaison between the Data Centre and the Games sites, and fourteen four-wire voice circuits were used for rapid reporting (See Table).

The data transmitting circuits demanded a very high degree of accuracy, and to this end careful study and tests were conducted in preparing the circuits by NTT, IBM Japan, Ltd. and the Organizing Committee personnel. Comprehensive tests were conducted by the NTT on all the circuits over a period of three months from July, and resulted in perfect circuit function of data transmission during

the Tokyo Games.

Teletype was used to transmit sports records processed at the Data Centre to news agencies and other news media. The actual method used was to feed IBM cards of sports records, converted to 5-unit punched cards, into teletype machines for transmission through distributors to approximately 20 news agencies and newspaper companies. The speed of transmission was 50-baud. This special teletype system and its related equipment was planned, designed and manufactured under the direction of the KDD, since ordinary teletype equipment used for domestic communication in Japan is the 6-unit system.

Number of cables for the leased lines used for Data-processing system

Location	133.2 Baud			1200 Baud (4W) Output	Control	Flash (4W)	Total
	Input	Output	Total				
National Stadium	4	2	6	2	4	2	14
Prince Chichibu Memorial Football Field	1	1	2		1		3
Tokyo Metropolitan Gymnasium	2	1	3	1	2	1	7
Tokyo Metropolitan Indoor Swimming Pool	1	1	2		1		3
National Gymnasium	2	1	3	1	2	1	7
National Gymnasium Annex	1	1	2		1		3
Komazawa Stadium	1	1	2		1		3
Komazawa Gymnasium	2	1	3	1	2	1	7
Komazawa 1st Hockey Ground	1	1	2		1		3
Komazawa 2nd Hockey Ground	1	1	2		1		3
Komazawa 3rd Hockey Ground	1	1	2		1		3
Komazawa Volley-Ball Court	1	1	2		1		3
Korakuen Ice Palace	1	1	2	1	2	1	6
Waseda Memorial Hall	2	1	3	1	2	1	7
Shibuya Public Hall	1	1	2		2		4
Equestrian Park	1	1	2		1		3
Nippon Budokan Hall	2	1	3		1		4
Main Olympic Village				1	1	1	3
NHK Broadcasting Centre		5	5	2	5	2	14
Tokyo Univ. Kemigawa Playing Grounds	1	1	2		1		3
Asaka Nezu Park	1	1	2		1		3
Toda Rowing Course	2	2	4	1	2	1	6
Lake Sagami	2	2	4	1	2	1	6
Asaka Shooting Range	2	1	3		1		4
Tokorozawa Clay Shooting Range	1	1	2		1		3
Hachioji Velodrome	2	2	4	1	1	1	5
Hachioji Cycling Road Race Course	2	2	4		1		3
Enoshima Yacht Harbour	1	1	2	1	1	1	5
Karuzawa Equestrian Events Ground	1	1	2		1		3
Yokohama Cultural Gymnasium	1	1	2		1		3
Mitsuzawa Football Field	1	1	2		1		3
Omiya Football Field	1	1	2		1		3
Total	43	25	68	14	47	14	143

Terminal equipment used for Data-processing system

Location	Modulator		Magnetic telephones		No. 50 type S 100 cable lines magne- tic switch board	Proving panel for 120 cable lines	Distribution for 14 cable lines
	200 Baud	1200 Baud	2 lines system	4 lines system			
National Stadium	6	2	4	2			
Prince Chichibu Memorial Football Field	2		1				
Tokyo Metropolitan Gymnasium	3	1	2	1			
Tokyo Metropolitan Indoor Swimming Pool	1		1				
National Gymnasium	3	1	2	1			
National Gymnasium Annex	1		1				
Komazawa Stadium	1		1				
Komazawa Gymnasium	3	1	2	1			
Komazawa 1st Hockey Ground	1		1				
Komazawa 2nd Hockey Ground	1		1				
Komazawa 3rd Hockey Ground	1		1				
Komazawa Volley-Ball Court	1		1				
Korakuen Ice Palace	2	1	2	1			
Waseda Memorial Hall	3	1	2	1			
Shibuya Public Hall	2		2				
Equestrian Park	2		1				
Nippon Budokan Hall	3		1				
Main Olympic Village		1	1	1			
NHK Broadcasting Centre	5	2	6	2			
Tokyo Univ. Kemigawa Playing Grounds	1		1				
Asaka Nezu Park	1		1				
Toda Rowing Course	2	1	2	1			
Lake Sagami	2		2				
Asaka Shooting Range	2		1				
Tokorozawa Clay Shooting Range	2		1				
Hachioji Velodrome	2	1	1	1			
Hachioji Cycling Road Race Course	2		1				
Enoshima Yacht Harbour	1	1	1	1			
Karuzawa Equestrian Events Ground	1		1				
Yokohama Cultural Gymnasium	1		1				
Mitsuzawa Football Field	1		1				
Omiya Football Field	1		1				
Press Centre	10	1	22	14	1	2	1
Total	175	15	70	28	1	2	1

Pamphlets and instruction booklets regarding the purchase and distribution of Games admission tickets



Admission tickets for each event

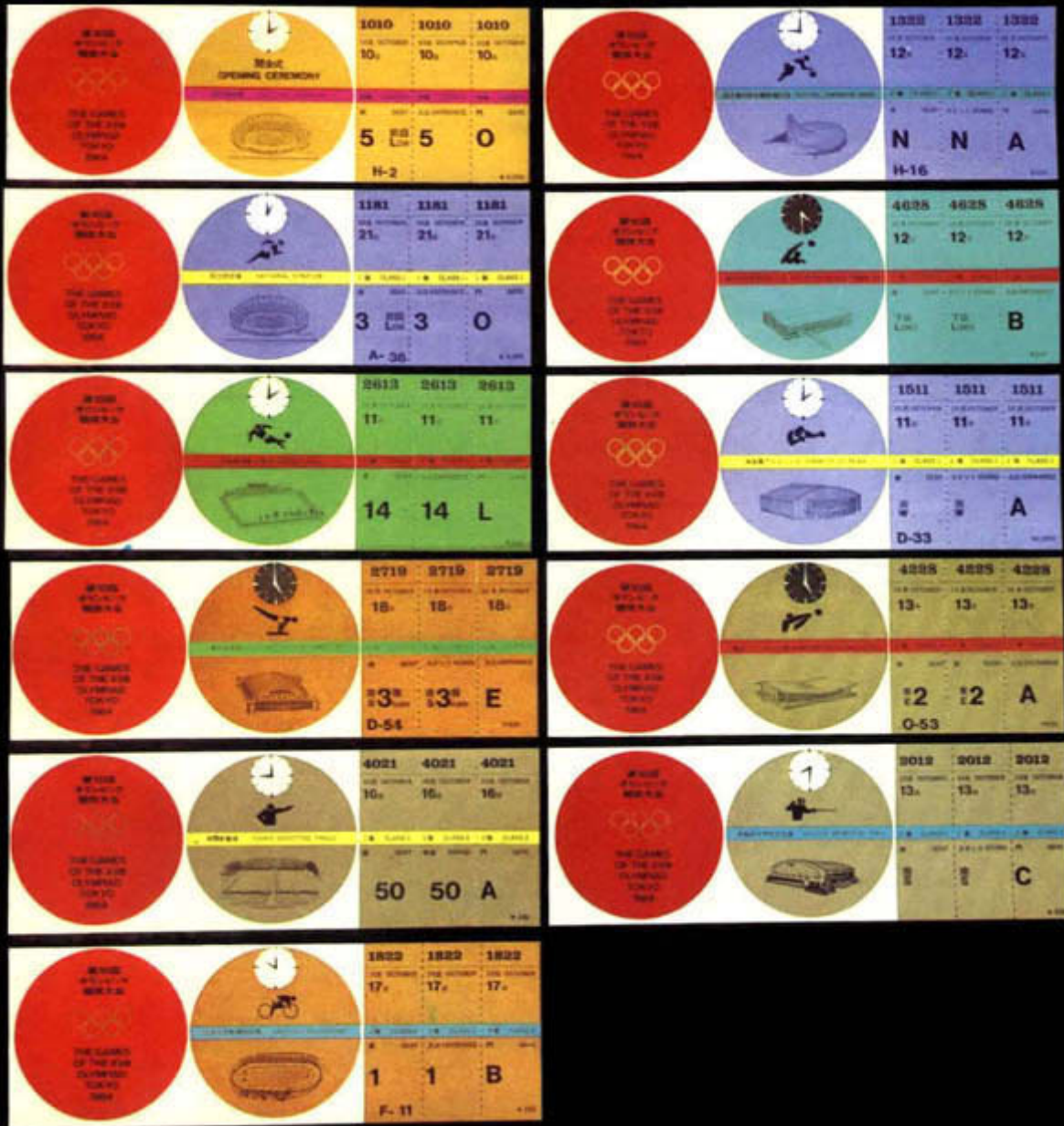



Tickets distinguishing the different sites



Plans and seating diagram of each games venue

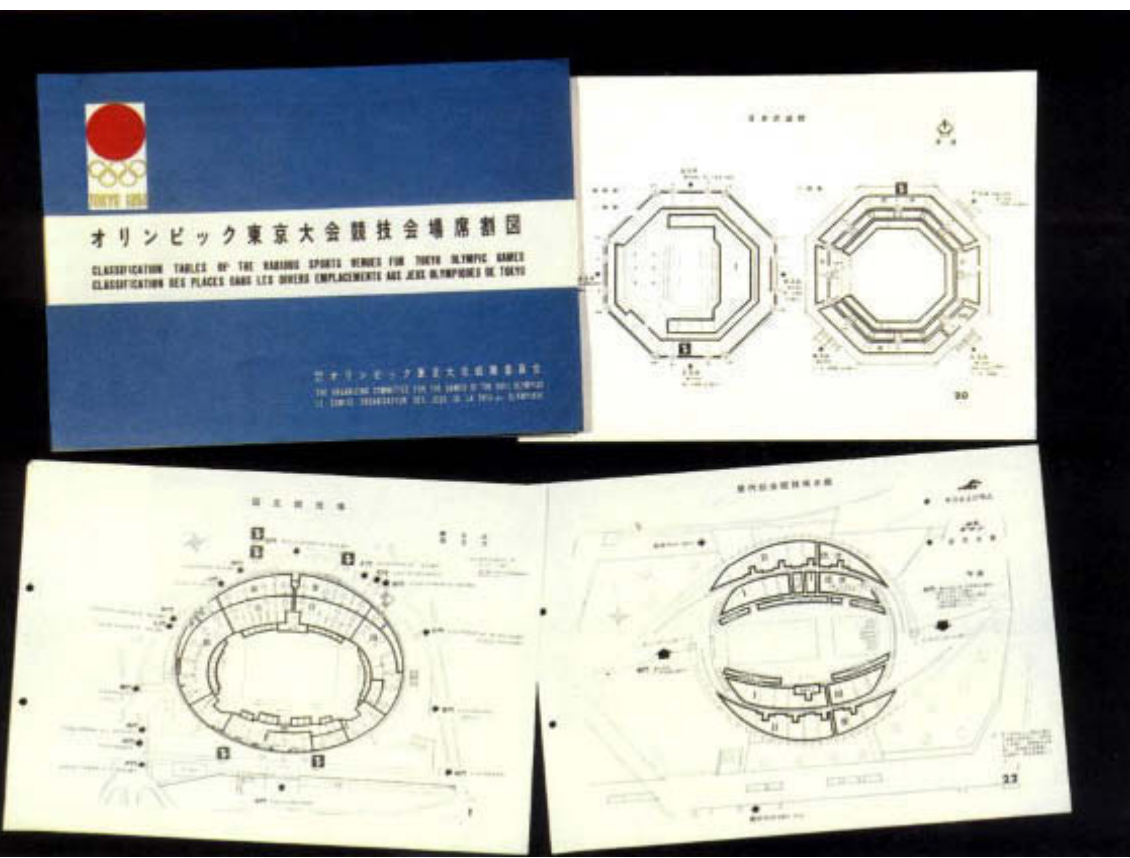

TICKETS

It was originally envisaged that the preparation and sale of tickets, provision of seats for officials and guests as stipulated in Article 48 of the Olympic Charter, the seats for general spectators, ushering, general assistance and directing to entrances of general ticket holders, would be the duty of a ticket section under the "Finance Division". However, in April 1962 as the result of a reorganization of the Secretariat, the "Ticket Division" composed of a "Sales Section" in charge of preparation and sales of tickets and a "Stadium Section" in charge of allocation of seats, ushering, directing and checking of tickets for the spectators was established. In April 1964, this was replaced by a "Stadium and Ticket Division" to include all services for the spectators, based on the experience in handling the Tokyo International Sports Week held in October of the preceding year, and also specifically for the purpose of consolidating the operation of the Games. The responsibility of checking admission tickets was transferred from the "Ticket Division" to the "Stadium Section", and the "Ticket Division" was renamed "Ticket Section". Under this new arrangement the "Stadium and Ticket Division" had a "Stadium Section", "Ticket Section" and "Medical and Sanitary Section".

Preparation

Basic principles regarding the sale of admission tickets, selection of agencies and actual prices of tickets, were established as early as 1961 after a number of diligent enquiries from agencies and organizations concerned and upon studies of the conditions which prevailed at previous Olympic Games. Several pamphlets were produced setting out those principles under which preliminary reservation applications were commenced, some 12-18 months before the date of the Games, and these times were gradually advanced to the actual sales admission tickets, first abroad and then domestically in Japan.

Important matters arising of a policy nature in connection with allocation or sale of tickets were referred to a Ticket Sub-Committee composed of ten members.

Outline of "Basic principles for admission tickets"

Admission price: The scale of admission prices was decided after consultation with economic re-

search and other related organizations and taking into consideration the admission prices prevailing at past Olympic Games and large scale sports events held in Japan.

Ticket designing: The design consultation group of the Organizing Committee was entrusted with the selection of suitable designers for the admission tickets. In this designing, care was taken to prepare a ticket which not only was an admission ticket for the Tokyo Games as such, but one which would by its design eliminate confusion of the holder as to sites or times of Games.

Sale of admission tickets:

(1) Organizations entrusted with the actual sales

Domestic Domestic general sales were entrusted to the Japan Travel Bureau. Actual outlets were selected from the J.T.B. nationwide network of offices and also playguides etc. and through Local Amateur Sports Associations. Tickets for persons in the field of physical education were allocated through the relevant Amateur Sports Association throughout Japan. Tickets for primary and junior and senior high school student groups were entrusted to the All Japan Prefectural Board of Education, the Japan National Federation of Private Senior and Junior High School Associations and the Association of National Universities of Japan. In addition, the Organizing Committee made direct allocations to certain particular organizations.

Overseas Each National Olympic Committee was asked to recommend reliable agencies competent to sell the actual tickets and at the same time to assist where required in travel arrangements. In principle one agency was established for each country.

(2) Outline of sales

Admission tickets for the Games were sold at the face value of the tickets through the agencies designated by the Organizing Committee. Exchange rates for foreign currency conversion was fixed for commercial at ¥1,000=\$2.80=£1.00.

Sales were conducted in two parts. First the "advance booking" or "Application for ticket reservation" and the "actual exchange of the advance booking voucher for the ticket". Under this sales system, the agencies accepted applications in advance accompanied by the price in full from applicants, within the limits of the classes and number of admission tickets specifically allocated to these agents by the Organizing Committee. Advance booking vouchers were issued and these were later exchanged for the vehicle tickets at a later date.

"The direct sales of tickets" were the later sales of any remaining admission tickets. These were issued directly on receipt at the agencies of the

amounts involved.

The Organizing Committee paid a commission of 5% of the face value of the admission tickets sold by the entrusted agencies. The agencies then remitted to the banking organization designated by the Organizing Committee, the balance of the sales receipts after deducting the amount of their commission at the agreed rate of 5%.

Domestic sales Here again both systems of sale were adopted, the cash sale system being used as the time for the Games drew near. However, admission tickets for persons connected with physical education, and primary and high school student groups, were handled only by the exchange voucher system.

Overseas sales Advance booking was accepted only for those who had secured accommodation reservations in Tokyo or its environs. The acceptable currencies by which the handling agencies could transmit the proceeds of ticket sales to the banking organization designated by the Organizing Committee were limited to free yen, American dollars or sterling pounds.

Day tickets sale In any cases where tickets remained unsold or any changes occurred in the Games programme, tickets were sold at the ticket offices on the actual days of the events. In these cases ticket sales outlets were established near the particular Games venue or at the actual site.

Allocation of admission tickets:

(1) **Allocations** The Organizing Committee allocated specific groups of tickets (including designation of the classification and price category) to each appointed sales agent. The agencies were then free to accept reservation application within that allocation on the prescribed forms. The actual tickets however were not issued until later.

The handling agencies in accepting applications, were required to receive the full amount involved, limiting their sales of course, only to the specifically defined tickets in their particular allocation.

Where the allocation was exhausted before the date specified for that allocation period, the Organizing Committee made additional allocations either on the basis of a general estimation of potential sales or by a specific request from the sales agent.

In cases where the Organizing Committee considered that the handling agency would not be able to complete the sale of the allocation before the date specified, the whole or part of the allocated number was reduced.

The unconsumed portions of the allocation was automatically cancelled by the Organizing Committee at prearranged dates for each allocation, and these portions were used again by the Organizing Committee in making future overall allocations.

(2) **Allocations for direct sale tickets** The allocation of actual direct sale tickets to domestic Japanese agencies was calculated after taking into consideration the relative allocation for advanced reservation applications and the actual number of applications already received.

(3) **Group admission of primary and high school students:** In order to enhance their understanding of the Olympic movement, it was decided to offer as many spectators' seats as possible to primary and high school students (including local schools for foreign residents).

Group admission was arranged as a part of the school itinerary, and this was implemented after consultation with the Ministry of Education, the All Japan Federation of Prefectural Boards of Education, the Japan National Federation of Private High School Associations and other related organizations.

Preparation of Admission Charge Table

The scale of admission charges was prepared in March 1963 based on the following principles and the procedures for operation.

Principles The International Olympic Committee had ruled that the admission charge shall be low to allow as many spectators as possible to attend these events. For the Tokyo Games the principle was adopted that the admission charges should be such that the charge would be acceptable to the general public in order to secure the maximum number of spectators while at the same time sufficient to return the expected income.

Standard for deciding the charges In deciding the range between the highest and the lowest charges for each event, the opinions of economic research institutions, and experts on matters of this nature were considered, and due regard was given to the conditions which prevailed at past Olympic Games and the various international sport events held in Japan, the purchasing power for these Olympic admission tickets based on consumer research in Japan and the degrees of popularity of the various sports within Japan.

Classification of seats was simplified for easier handling of spectators. On the other hand efforts were made to increase the number of spectators by adopting a two-shift system where it was possible to do this in the programme without interrupting the smooth operation of the Games.

A small series of "through tickets" was prepared for each sport, for the convenience of the people connected with sporting groups. The price of these through tickets was the aggregate of the single

tickets.

The group admission charges for primary, junior and senior high school students was fixed at the same price for all events. This was decided after consultation with educational organizations including the Ministry of Education, and with the intention of offering as many spaces as possible at minimum charges.

Formula used to estimate the number of general spectators In deciding the admission charges, an attempt was made to calculate a rational basis for the relationship between the admission charge and the number of spectators.

By making a statistical analysis of the number of admission tickets sold per event at the Third Asian Games held in Tokyo in 1958, a mathematical formula was selected which might best explain the factors for selling admission tickets.

This mathematical formula was modified using the factors such as (1) the degree of popularity of each of the sports on the programme, (2) factors of the Games the XVIII Olympiad which would be different from those existing at the Third Asian Games, (3) population trends in Japan between both Games, (4) change in economic indexes, (5) difference in popularity between preliminaries and finals, (6) change in the numbers of admitted spectators where the two shift system was adopted.

This mathematical formula made it possible to clarify how many tickets could be expected to be sold if the admission charge per event was fixed at a certain figure.

This formula proved useful in judging whether or not any proposed change for any particular event would be equitable.

$$\log N = A + \log \alpha + \log \varepsilon + B [-\log P + \log \beta]$$

N—accumulated number of tickets sold by event and charge

A—constant

α —increase in population factor

ε —effect of the two-shift system

B—value flexibility according to popularity of preliminaries and finals of each event

P—admission charge

β —economic growth factor

Actual record of tickets sold Calculations based on the formula disclosed that with the estimated number of general spectators it could be expected that with these admission charges the spectators would be about 70% of capacity. The actual result however, was far above this estimate. This was probably due in part to an overestimation of the modifying factors, and in part due to the promotional efforts for sales of admission tickets.

Allocation of Number of Seats of Each Class at Each Site

Factors for seat allocation The allocation of seats was decided after consulting with the organizations concerned based on the following factors, (1) the maximum number of spectators which could be handled without providing an impediment to the smooth operation of the games, (2) classes should be classified based on the characteristics of the event and the position of spectators, (3) preparation should be so made that factors of safety, ushering, control of spectators were given full consideration, (4) free seats as stipulated in the Olympic Charter should be carefully arranged to avoid any possibility of confusion.

Seat allocation operation The actual allocation was carried out in terms of the regulations after considering all the above factors and not before due deliberation on fire prevention regulations, the experience of past Olympics, the structure of the site, surrounding topography, transportation facilities, "human flow", etc. had been made. Then the total number of seats and the necessary free seats were calculated. The free seats were arranged in order of priority around the Royal Box and the remainder were allocated to seats for the general public, and groups seats for school students.

Calculation for seat allocation In calculating the number of seats at the sites, blue-prints were used inasmuch as almost all sites were either in the process of alteration or enlargement. Some seats were reserved for emergency use.

The calculation of the number of free seats was a matter of some difficulty, as estimates only were available of the number of the personnel under Article 48 of the Olympic Charter who would be present at each site after the Opening Ceremony, and as these seats occupied central positions, any change in the numbers of these seats would affect the arrangement of the entire stadium.

The crescent type stand to be additionally installed in the upper part of the backstand of the National Stadium, which was to be the main site of the Games, was originally planned as a standing room. However, in view of the administration of the site, this was changed to provide seating accommodation.

For the Opening Ceremony an additional temporary stand was installed to increase the capacity. The seating allocation having then been finalized for the National Stadium, the arrangement of seating at all other sites was based on these standards. It should be recorded here that the following matters which were encountered in the process of seat-

ing allocation: At the Equestrian Park, a riding ground was required to be changed into a riding hall for rainy days; Road traffic had to be suspended for some time to construct temporary stands for the road race of cycling at Hachioji; The allocation of boats to each course and the number of persons who could view the race from this vantage point presented some difficulties; A modification of the ticket issuing programme was found necessary as a result of the partial change in the site construction plans, etc. (The actual seating arrangements can be seen from the charts and tables.)

Sales Organization of Tickets

Based on the above-mentioned system, the domestic and overseas selling organizations and the procedural routes were decided as follows:

Domestic ticket handling organizations and issuing points were designated as under and the contracts were concluded during May 1962.

- Japan Amateur Sports Association
Member Organizations of the above Association (36 groups)
Prefectural and Amateur Sports Association, including Okinawa (47 Associations) } (to people connected to physical education)
- Prefectural Educational Superintendents Council
Association of National University Schools of Japan
Japan National Federation of Private Senior and Junior High Schools Association } (to primary, junior and senior high school students' groups)
- Offices of the Japan Travel Bureau (162)
Play-guides, etc. (39) } (to general public)

Overseas handling agents are as shown in the "general table showing overseas ticket handling agents". Contracts were concluded with 87 agencies.

(Note) Recommendation of handling agents was requested from each participating NOC as of March 1962 with the exception of Japan. Some of NOC's did not however make any recommendation, and only 87 agencies were appointed. The committee handled directly any applications for tickets from persons in areas when agents had not been appointed.

Ticket Allocation

Admission ticket allocation policies for overseas and domestic public, physical education groups, organizations related to the Games, etc. were decided after deliberation by the Admission Ticket Sub-Committee.

Allocated number of tickets for the Opening and Closing Ceremonies Emphasis was laid on the allocation to the general public and more than half of the issued tickets were used for this purpose. One third of these was reserved for overseas use, and the remainder was allocated to domestic physical education groups, etc. However, in view of the past experiences, the number of the tickets for foreign visitors for the Closing Ceremony was reduced by 5,000 and this number was allocated to the general public, physical education groups, etc.

System of ticket sales handling

(Application for ticket reservations)

- Reservation applications
- - - - - Cash payments
- Tickets distribution

(Actual tickets sales)

"Reservation applications route" will be replaced by "Sales" reporting route.

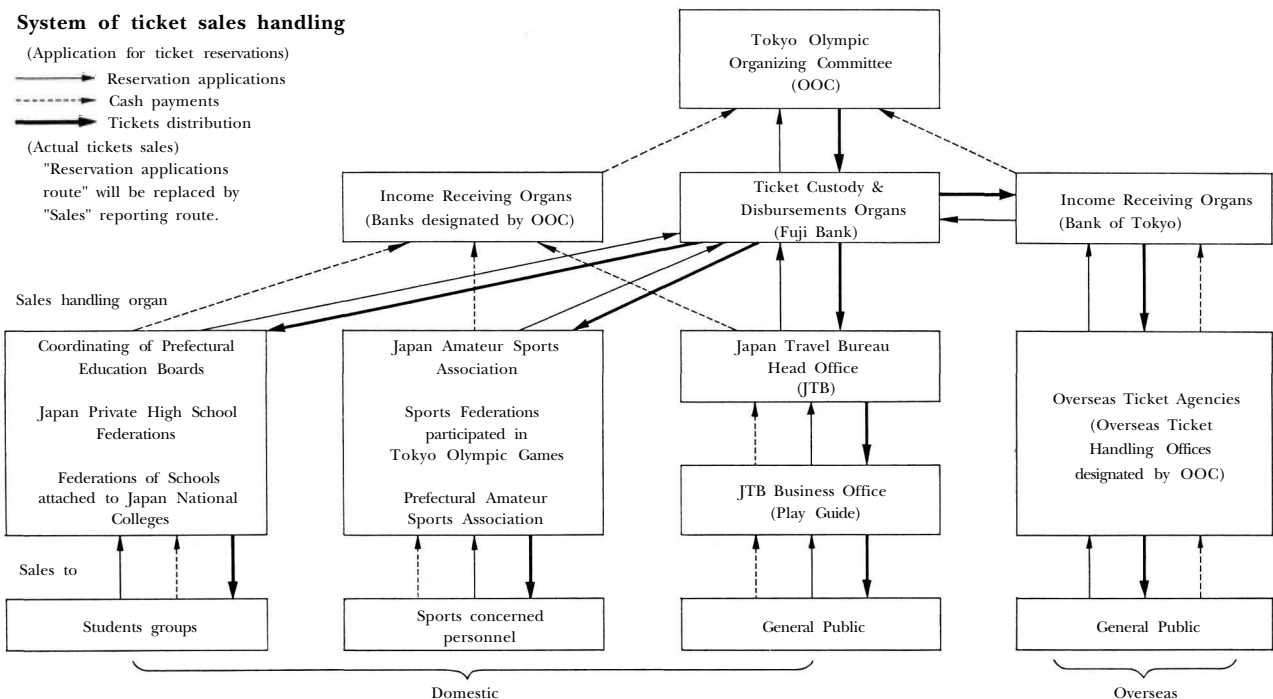

Allocated number of tickets for regular events

As in the case of the Opening and Closing Ceremonies, emphasis was laid on the general public and special consideration was given to persons in the fields of physical education in Japan, children, students, and "the Olympic Fund Raising Association" which was responsible for raising a large section of the funds required for the Tokyo Olympic Games.

The total number of tickets allocated for overseas use was fixed at 200,000 in consideration of the available accommodation capacity in Tokyo, the yearly number of foreign visitors to Japan, and the estimated number of tickets per person, etc.

The allocation frameworks for the admission tickets to be allowed each purchaser was decided on the following basis in order to provide equal opportunity to purchase tickets in each area.

Allocation of tickets for regular events for the general public within Japan:

Tickets for the Opening and Closing Ceremonies were handled on a drawing sales system to ensure fair distribution of the large number of applications for the scarce number available. 500,000 events admission tickets were allocated to domestic agencies as the first allocation. In making allocations the Organizing Committee first calculated an allocation percentage for each prefectural unit and decided the number of tickets

Estimation of likely ticket distribution

(as at June 1963)

Area	Opening Ceremony	Closing Ceremony	Sports events	Total
Total No. issued	60,094	60,094	1,916,331	2,036,519
Distribution to				
Overseas	20,000	15,000	200,000	235,000
Domestic				
General	30,144	32,594	841,825	904,563
Sports Associations	3,850	5,500	180,000	189,350
Student Groups	900	900	561,006	562,806
Fund Raising Association	900	1,800	133,500	136,200
National Diet	735	735		1,470
National Government	600	600		1,200
Metropolitan Government	600	600		1,200
Prefectural Sports Assn's	200	200		400
Press and Publicity	900	900		1,800
Others*	1,265	1,265		2,530

* include IOC, IF's, NOC's and Sport Science Congress delegates, etc.

for each event. The Japan Travel Bureau, which was the central office for domestic sales, decided the specific allocated number of tickets for each handling agency, based on the sales records of railway tickets and the size of the agency involved.

The Organizing Committee used the following calculating allocation percentage for prefectures: (1) distance from Tokyo, (2) participation of prefectures in the national athletic events, (3) winners of the Emperor's Cup at those events, (4) populations of prefectures, (5) prefectural income, (6) amount of budget by prefectures. From an investigation of the correlation coefficient between these factors, it appeared that this economic and social phenomenon could be expected. Taking into consideration the distance from Tokyo, and average family income of each prefecture, and expressing the distance by the cost of the train fare to, and lodging expenses in, Tokyo.

$$\text{Allocation percentage} = \frac{I}{A + B + C}$$

Where A = Train fare from the capital city of prefectures to Tokyo. 1st class or express or extra charge for sleepers was used.

B = Cost of lodging in Tokyo.

C = Average cost of tickets for Tokyo Games plus food expenses expected to be spent at the site.

I = Prefectural income.

This formula then was used to give an indication of the likely demand for admission tickets from each prefecture in Japan.

Persons living in the areas surrounding Tokyo could purchase their tickets in Tokyo. This calculation was arrived at in the following calculation:

$$\frac{I}{A + B + C} = X + Y$$

Where X = Percentage of the cases where tickets are purchased at one's residential area.

Y = Percentage of the cases where tickets are purchased in Tokyo.

The percentage, X was allocated to prefectures, and Y was added to Tokyo.

This supplementary addition was applied also to Osaka and Nagoya.

The allocation percentage based on this calculation formula was applied to the allocation tickets for each event. Later the actual results of the initial sales period for each prefecture were taken into consideration in making the allocation for the

second sales period.

Overseas allocation: Half of 235,000 tickets destined for overseas use were allocated as the first allocation in September 1963, after calculating the allocation percentage per country based on (1) statistics for each country of foreign visitors to Japan in recent years, (2) lodging reservations for overseas visitors in Tokyo and nearby areas as of 15th July 1963, (3) the answers to a questionnaire submitted to handling agents in various countries, regarding their estimated demand, (4) actual sales of tickets by country and event for the Games of the XVII Olympiad (Rome). The second half of this main allocation was later distributed as handling agents made requests for additional allocations. Efforts were made to satisfy the actual demand where possible.

In June 1964, staff personnel were sent to all principal overseas handling agencies and the unsold portions of ticket allocations were withdrawn where it appeared that there was prospect of further sales. These tickets were then reallocated to ticket agencies requesting additional allocations.

Group allocation: The allocation of about 560,000 groups tickets for primary, junior and senior high school students including resident foreigners' schools were discussed in March 1963, at a "Liaison Conference for group admission at the Tokyo Olympic Games" and an allocation programme reflecting the consensus of opinion of the whole educational circles in Japan was prepared.

Early surveys showed that the demand for student group tickets was some four times the number of available tickets, and consequently a system of allocation had to be instituted to ensure fair distribution.

Areas from where it would not be possible to see the Games by a day trip were determined based on

the actual record for annual school trips each year and lodging records in Tokyo. All other areas were regarded as places from which it would be possible to commute to see the Games. The following percentages and weights were used in allocating these student group tickets:

Resident foreigners' schools were handled directly by the Organizing Committee.

Allocation for persons in physical education fields:

Allocations were made to persons related to physical education, through the Japan Amateur Sports Association, its member organizations, and Prefectural Amateur Sports Association. The actual allocation was left to the discretion of the Japan Amateur Sports Association.

Sale of Admission Tickets

Domestic sale After deliberation by the Admission Ticket Sub-Committee, ticket sales and the sales method were arranged under the following considerations:— (1) to offer equal opportunity to purchase, (2) to as far as possible accommodate the wishes of the sport loving public, (3) to avoid confusion at the time of sales. In October 1963, the acceptance of reservation applications for the general public (1st stage sale) was started. At that time a drawing system was adopted for those desiring Opening and Closing Ceremony tickets, and event tickets were sold to the extent to which they were available.

The Organizing Committee disseminated details of these methods of handling to all appointed ticket agents, post offices and railway stations, and arranged ample publicity also through newspapers, television and radios throughout the country.

Tickets for the Opening and Closing Ceremonies:

Sales method Drawing was made from applicants who applied using the stipulated return post

School	Handling agency	Allocation percentage	Note
National schools	Association of government university schools of Japan	1	Percentage per event per day per 1 section or 2 sections was decided by drawing.
Public schools	Prefectural educational superintendents council	81	
Private schools	Japan national federation of private senior and junior high school associations	18	

cards. Those who were successful in drawing could apply for reservations at official ticket agents.

Rules for application The application period was from 16th to 30th October 1963 (postmark date). Applications were limited to one ticket per person for both the Opening and Closing Ceremony. Official return post cards were to be used. Cards were required to be addressed to the Ticket Division of the Organizing Committee. Cards were declared invalid when not completed in the form stipulated or where the contents were ambiguous. Applications were only accepted from individuals and not more than two tickets per person. Applications were required to be handwritten.

The return card was returned with the draw numbering printed. Successful applicants were required to apply for reservations by presenting the card to official ticket agents.

A public drawing was held at the Hibiya Public Hall and the event was televised or broadcast through NHK.

Application period for ticket reservations During the permissible period of application from 25th January 1964 to 5th February, application for drawing for Opening and Closing Ceremony tickets were received as follows:—

	Number of tickets available	Applications received	Ratio to available tickets
Opening Ceremony	30,200	2,628,130 (effective)	87.0 times
Closing Ceremony	30,300	917,014 (effective)	30.3 "
Total	60,500	3,545,144 (effective) 107,384 (invalid) 3,652,528 (Total)	58.6 times 60.4 times

General admission tickets:

The 1st stage sale (acceptance of reservation application) Reservation application were limited to one kind (the same event, site, date and class) per person, and a maximum of two. In the case of football a maximum of five were allowed.

The admission ticket applications not claimed were voided after 7th February in Tokyo and Osaka and these were then released under a first-come-first-served system at the ticket agencies.

The second stage sale Actual tickets were sold in the second release allotment from 2nd to 20th August 1964. The number of handling agencies was decreased to 98 in order to expedite recovery of any remaining tickets.

Applications for tickets were first accepted under the following headings and dates:—

Stage	Date	Event
1	25 Oct.	football, yachting, rowing, budo demonstration
2	8 Nov.	hockey, shooting, modern pentathlon, equestrian sports, canoeing
3	12 Nov.	weight-lifting, water-polo, fencing, cycling, baseball demonstration
4	15 Nov.	wrestling, boxing
5	19 Nov.	volley-ball, judo demonstration
6	26 Nov.	gymnastics, basket-ball
7	29 Nov.	swimming & diving
8	6 Dec.	athletics (However, for Tokyo and Osaka area the first half on 6 Dec. and the latter half on 7 Dec.)

The third stage sale Any remaining tickets (domestic or overseas allocations) were released for actual sale from 18th September. Handling agencies at this stage were reduced in number to 19 in Tokyo one each in Yokohama and Urawa—a total of 21.

Day ticket sale Remaining tickets for four of the events, namely, rowing, yachting, equestrian sports (Equestrian Park), shooting (rifle) were released on the day of the event. However, as it was expected that all tickets for other events would be exhausted by advance sales, sales of these were continued at the handling agencies continuously from the third stage sale.

Sales to those directly related to physical education: Tickets for persons related to physical education were sold through the Japan Amateur Sports Association, various sports groups and Prefectural Amateur Sports Association under the application-for-reservation formula, from January 1964 to 30th June.

Sales to primary, junior and senior high school students groups The application period for tickets under the heading was April 1964 to June. In February the same year allocation notices and application forms for ticket reservations were sent to various group ticket handling agencies.

Admission charges At each site the charge was ¥100 (US\$0.28) per person for primary and junior high school groups and ¥200 (US\$0.56) per person for senior high school groups.

Accompanying teachers were charged the same amount as children or students (¥100 for primary and senior and junior high school student groups in the case of baseball and budo demonstrations).

Handling by areas As for primary schools, areas were limited to places where children could travel to and from the games in one day. Such areas were in fact limited to the Kanto district (7 prefectures).

For the junior and senior high school students, the area where students could come to the Games by day trips included Shizuoka and Yamanashi prefectures in addition to seven prefectures in the Kanto area. The area from which students could make overnight trips to Tokyo were in principle places where students came Tokyo each year on school excursion.

Unit of group admission The group unit was fixed at 20 children or students accompanied by one teacher (two where number was more than 21 and less than 60).

Admission handling per event per day or night—Only high school students were admitted, in principle, to weight-lifting (the whole period) and Grand Prix Dressage (Equestrian Park—the whole period).

Only senior high school students were admitted, in principle, to night basket-ball, boxing, wrestling, gymnastics, swimming and water-polo events.

Group ticket applications "Certificate of group admission" and "group admission tickets" (a single ticket for each group) were issued through the respective handling agencies to the schools for which group admission application was accepted.

The Organizing Committee directly handled group admission for children and students of foreign residents' schools and children of special assistance establishments, etc. under the Ministry of Health and Welfare. Some 8,000 persons connected with foreign residents' schools and 7,000 of the Ministry of Health and Welfare establishments were admitted as groups.

Overseas sales As a preparatory measure to the actual overseas ticket sales, various printed materials was despatched, and the individual desires of the various countries regarding specific ticket allocations were ascertained.

In September 1963, the variety and numbers of tickets for the first stage allocation were announced and advance reservation applications were accepted from 25th October, in the same way as the domestic sales. Additional requests for allocations were accepted from overseas handling agencies for persons who produced evidence that lodging reservations had been secured in Tokyo. It was not always possible however, to meet all varieties and numbers of tickets specifically requested, but as far as possible

the demands of each request were satisfied.

The Japan Travel Bureau handled the tickets to members of diplomatic missions in Japan, the World Youth Camp participants and any foreign visitors who came to Japan without tickets. Tickets were sold to games participants and officials at the JTB offices set up at the Olympic Village, while the Organizing Committee distributed tickets directly to the IOC, each NOC, ISF, and foreign news media personnel, etc.

Actual exchange of tickets: Some apprehension was felt as to the smooth exchange of actual tickets for the exchange vouchers in distant overseas countries. Efforts were thus made to despatch these tickets far in advance to avoid last minute complications. To forestall any possible incidents, the tickets sent out were microfilmed and the actual despatch was started from the end of May 1964. For those applications received toward the end of the final sales period, alternate delivery in Tokyo was in some cases adopted. In all cases applicants were able to receive their tickets in time for the event, and there were no cases where mailed tickets did not reach the addressee.

Link system with lodging reservations: One of the peculiarities of the overseas sales in this occasion was the system linking tickets with lodging reservations. Tickets were sold only to those persons overseas who produced evidence that they had secured lodging reservations in Tokyo or its environs.

This system was not intended in any way to restrict the sales of the tickets but was instigated to avoid confusion that might arise if persons who purchased the tickets were not able to find accommodation upon arrival in Japan.

Persons desirous of purchasing tickets were asked under this system to obtain reservations for lodgings through hotels, inns, travel agents, or the Tokyo Olympic Housing Office, etc. and to obtain a certificate evidencing that reservations for lodgings had been completed.

To fully acquaint Olympic visitors from abroad with this system of linking, the Organizing Committee fully informed each handling agency and NOC concerning lodging facilities in Tokyo and the method of making application both for accommodation and for admission tickets to the Games.

Ticket Design and Printing

Design Mr. Hiromu Hara of the Japan Design Centre, chosen by the design consultation group for the Organizing Committee, was asked to prepare the ticket design and this was completed in March 1963. The general aim of this design was to symbolize the image of the Tokyo Olympics, and also to exemplify the Japanese concept of simplicity, while yet making it practical in the various requirements of tickets for an International Sport event of this nature.

- The red circle on the left hand side of the ticket was used in all tickets as the symbol of the Tokyo Games.
- Name of event, the site and starting time were expressed graphically in the central circle. Different colours were used for each site in this circle. In particular, golden colour was used for the opening ceremony and silver for the closing ceremony.
- Two-thirds of the square on the right hand side was torn off as the ticket holder entered the site. In this square, the ticket classification, number, date, entrance, seat, price, etc. were shown. The horizontal belt in various colours indicated the respective class of the seat.
- In order to prevent forgery, a watermark was inserted at a certain part of the ticket and the drawing of the stadium was printed from copperplates.
- On the back side a plane figure of the site and cautions were printed so that the holder might be fully acquainted with the position of his seat and the entrance to use.
- The size was 80mm by 233mm with the ratio of 1 to 3. When the square part was folded, only the red symbol on the left-hand side was visible thus giving a strong and bold impression.

Paper used "Stereo watermark machine-made Japanese paper for security printing" was used as the paper for all tickets. Here too care was taken to preserve a Japanese impression. This paper was specially developed to give the appearance of a relief watermark, inasmuch as an actual relief watermark is prohibited by law for use other than on currency bank notes.

Printing Printing was handled by two major printing companies in Japan. Actual printing was commenced in October 1963 and 2,100,000 tickets in 1,385 different varieties were completed in May 1964.

Surface: The colour part consisted of four gravures. "Red" for the rising sun and "golden" for the five circles were common in all tickets. The sites were classified into six colours by area and

classes of tickets were shown in seven colours.

Spaces of black were made in relief printing and were printed differently according to the classification number, event, site, date, entrance, and seat number.

Reverse side: This was in offset printing in two colours. A plan of the site, cautions and general area indication of site were printed in different colours.

In addition to the complicated printing methods requiring more than ten changes and different printing machines for gravure, relief and offset, the printing programmes had to be modified due to changes in the actual seat allocations as a result of the final site planning, and alterations in the final number of available seats, seat numbers, and entrance signs after the printing had in fact begun. Some apprehension was expressed that these changes and consequent delays would cause complications, but thanks to the wholehearted cooperation of the printers, and others involved, and of the handling agencies, the first exchange of reservation applications for tickets was completed on schedule.

Holding, Delivering and Receiving of Tickets

The Fuji Bank was asked to be responsible for the storing, delivering and relevant documentation for the 2,100,000 tickets involved.

Holding, delivering and receiving The tickets delivered by the Printers were examined in the presence of inspectors from the Organizing Committee. It was arranged to release the better seats to early applicants in order of application. After deciding the order of delivery for each class, the tickets were stored in a special safes.

Tickets for the general public in Japan were delivered to the JTB and those for overseas visitors to the Bank of Tokyo in bulk after confirming receipt of the proceeds for the tickets. The JTB sent these tickets by means of its special messenger service, and the Bank of Tokyo despatched these by airmail to handling agencies overseas. Tickets were directly delivered to physical education groups in Tokyo by special delivery with advice of receipt requested, while the group tickets for primary, junior and senior high school students were directly handed to handling agencies for national, public and private schools. Great care was thus exercised to ensure correct and efficient delivery.

Materials on management and statistics Preparation of handling materials to the some 400

ticket handling agencies both domestic and overseas, the receipt of sales reports, checking of the remittances and statistics was handled by electronic computers, and the following returns were prepared each month.

- Inclusive table showing ticket sales per handling agency and per kind and class
- Inclusive table showing ticket sales per kind and class and per handling agency
- Table showing total sales per handling agency
- Table showing total sales per kind and class
- Inclusive table showing the remitted money per bank and per handling agency

Overall Ticket Control

In handling operations concerning tickets during the period of the Games, emphasis was laid on the service to spectators and the maintenance of order at the sites.

—Function arrangements

Affiliation:

Admission Ticket Section of the Secretariat

Responsibility:

- (1) Operation sub-section
 - Contact with related agencies.
 - Public relation work concerning admission tickets.
 - Operational programme of information offices.
 - Sales of day tickets.
 - Preparation of operational daily reports.
 - Handling of any complaints.
 - Any refunding of the admission ticket monies involved.
 - Other matters related to tickets and not specifically covered by other sub-sections.
- (2) Administration sub-section
 - Receiving and handling of above-mentioned tickets.
 - Accumulation of the number of day tickets sold (expected number of sold tickets, actual result of sales, etc.).
 - Preparation of various statistical materials (materials for the announcement on the sales result each day at each site).
- (3) Overseas Sales sub-section
 - Handling of any complaints concerning tickets for overseas use.
 - Exchange for tickets for overseas use.
 - Contact with the investigators from abroad.
- (4) General Affairs sub-section
 - Payment of wages.
 - Preparation of lunches, snacks, etc.
 - Receiving and handling fixtures and consumption goods.
 - Arrangement of vehicles.
 - Other general affairs matters.
- (5) Group admission
 - Contact with various group admission or-

ganizations.

Allocation and placing of signs.

Receiving and handling of fixtures and consumption goods.

Payment and supply of transportation expenses, lunches, etc.

Handling of any complaints concerning group admissions.

Contact with policing, communication fire prevention related organizations.

Other matters concerning group admission.

Affiliation:

Ticket offices at the various Games sites

In charge:

- (1) Day ticket sale
 - Guidance and supervision of the business of day ticket sales conducted by the sales handling agencies.
 - Business instructions to sales handling agencies based on the instructions from the chief of office, sections and other related agencies.
 - Preparation of reports on the actual results of day ticket sales.
- (2) Information
 - Distribution of games schedules and programmes.
 - Information on transportation facilities and other facilities inside and outside the sites.
 - Information on day ticket sales.
 - Information on tourism and lodgings.
 - Acceptance and disposal of various grievances.
 - Public relations concerning admission tickets.
- (3) Group admission
 - Contact with headquarters and chapters of group admission organization.
 - Contact with group admission operation sub-section.
- (4) Handling of any complaints
 - Satisfying of grievances transmitted from information offices, etc.
 - Disposal of tickets reserved for emergencies, steps for refunding admission ticket prices.
 - Satisfying of other grievances concerning admission tickets.
- (5) General affairs
 - Payment of wages, etc.
 - Preparation of lunch, snacks, etc.
 - Receiving and handling of fixtures and consumption goods.
 - Arrangement of cars.
 - Preparation of daily operation reports.
 - Disposal of other matters concerning admission tickets.

—Allocation of personnel

Office personnel who had thorough knowledge of the nature and outline of the operations worked under the office-in-charge of each Games site. All had received training including on-the-spot training, from about two months before the opening of the Games.

Conclusions

The difficult problem which those in charge of admission tickets experience in all Olympic Games is the fact that the sale of admission tickets starts some twelve months before the opening of the Games at the latest, and that the tickets operations must therefore, precede preparatory works of other related departments to that extent.

The Tokyo Olympic Games were no exception, and this office was required to early handle the large amount of necessary preliminary arrangements such as collection of data, analysis, comparison, estimate, calculation based on special formulas, etc.

The fact that the tickets were sold quite extensively and that good order in and outside the event sites was maintained, contributed very much to the success of the Games. However, there were still some problem, and these are recorded as follows for reference in the future.

Grievances by foreign visiting spectators concerning the purchase of admission tickets

There were some foreign spectators who came to Japan without purchasing admission tickets through the handling agencies in their countries of residence, under the mistaken idea that they could purchase tickets easily in Tokyo. The fact that almost all of these persons were paying guests in private homes shows that the contact facilities or assistance to them was insufficient and they were travelling without the help of tourist agencies in their own countries.

Since some of the designated handling agencies appeared to have a tendency to give preference to those who used their coupons, tourists handled by other agencies or paying guests at private homes made some complaints of the difficulty of readily obtaining admission tickets through official overseas agencies.

Grievances caused by the change in schedule due to non-participation in the Games

(1) Due to the withdrawal of the Italian football team, and the non-participation of Indonesian and North Korean teams immediately before the start of the Games, a partial suspension of football games, earlier starting and closing hours for hockey games, etc. was found necessary. This news was fully publicized through various news agencies in addition to advertisement in the newspapers throughout the country. However, some holders of tickets for suspended games expressed their wish to exchange them with tickets for some other games, while some of those persons who could not in fact arrange to see the games on the new scheduled time, submitted complaints.

(2) Cycling was postponed repeatedly on account of the rain on the scheduled date and this resulted in holding the events in the morning and in the

afternoon on the same day, though originally scheduled to have been held on two consecutive days. This caused some inconveniences to the spectators.

The cause of complaint was that the change in the games schedule was not quickly decided and it was thus impossible to make adequately wide publicity because of the available time.

It will be advisable in future Olympic Games to establish sufficient reserve days for the games which are influenced by the weather and by deciding a standard of decision whether the game will be held or not, by presuming various cases beforehand, to enable ample preparation and to allow adequate publicity if such a cancellation or postponement should become necessary.

Grievances concerning the use of admission tickets for two section events

At the event sites where a shift system for spectators was adopted, a small number of ticket holders complained that "They thought that they could see the second section with the ticket for the first section." or "They did not know the closing hour of the first section."

This was apparently because in the upper part of the ticket, a clock-dial design was the only indication of the starting time of the game "by a black needle on a white paper for the first section" and "by the white needle on the black paper for the second section." Notices were inserted also in the game programme and game information diagrams. When this inadequacy was brought to the attention of the Organizing Committee, strenuous efforts were made to publicize this adequately by taking such immediate steps as newspaper advertisements, notices posted at the site, broadcasting by television and radio, and increasing the number personnel on duty, etc. As a result no particular hitch occurred in connection with the operation of these Games. However, it was regrettable that some inconvenience was apparently caused even though this fortunately was confined to a small section of the spectators.

Actual result of the group admission of primary, junior and senior high school students

The large scale group admission of primary, junior and senior high school students, which was the first such arrangements in Olympic history, gave a favourable impression to young people and contributing to the understanding of the purpose of the Olympic movement. Thanks to the cooperation of school education people and policing authorities and the careful and detailed preparation made before the events, the groups came and left in an exemplary manner in perfect order without any of the accidents and incidents that had been the subject of concern by many. The only regret in this connection was that due to the cancellation of some six football games many of the young children were greatly disappointed in not being able to fulfil their promised dream of witnessing an event of the Olympic Games in Tokyo.

Progress plan by years for ticket sales

	Concerning Sales	Concerning Venues
1961 (July)	Decision on basic policies concerning preparation and sales of tickets such as entrusted agencies, charges, design, etc.	1. Collection of materials concerning the past Olympics and sites of games and study on seat allocation. 2. Survey of capacity at each site and decision on the number of tickets to be issued, with some estimation of the probable games programme.
1962 (March)		
1962 (April)	1. Decision on actual scale of admission charges. 2. Selection of ticket designers. 3. Request to each NOC and Local Amateur Sports Associations for recommendations of ticket handling agencies. 4. Decision on ticket allocation standard for each handling agency. 5. Decision and printing of forms for admission ticket reservation application and other related business forms.	1. Preparation of seat charts showing the seats for persons so specified in the Olympic Charter, and allocation of areas for general public classified according to category of seats. 2. Decision on whether or not to adopt a two ticket system for those events held in two sections on the same programme.
1963 (March)		
1963 (April)	1. Designation of and making contracts with ticket handling agencies, domestic and abroad. 2. Sending of ticket programmes and other business forms to all agencies. 3. Information to agencies about kind and number of tickets to be allotted and commencement of receipt as actual reservation application. 4. Printing tickets. 5. Decision on receiving reservation application from primary and high school student groups.	1. Amendment of seat chart and preparation of seat tables with the progress of stadium preparations. 2. Decision on allocation of entrances and ticket checking points for persons connected with the games, general public and primary, and high school student groups. 3. Decisions on methods of ushering and directing to stadiums, investigation of overall traffic situation and human flow, and mapping out of various necessary signs and directions. 4. Plans to set up places to sell tickets on day of events.
1964 (March)		

1964 (April)	1. Additional allocation of admission tickets and allocation adjustments. 2. Acceptance of applications from primary, junior and senior high school groups. 3. Sales of actual tickets for general public in Japan. 4. Delivery of tickets to reservation applicants. 5. Decision on day ticket sale and allocation of sales personnel. 6. Publication and dissemination of details to be observed by spectators attending the games. 7. Decision on measures to be taken in connection with the treatment of tickets in case of cancellation or postponement of events, etc. 8. Establishment of actual games operational system for the games.	1. Survey of actual seats required for persons connected with the games and general public and adjustment on the number of admission tickets issued. 2. Completion of personnel allocation for day tickets sales, ushering etc. and instructing and training of these persons. 3. Preparations for acceptance and disposal of complaints or problems arising in connection with admission tickets.
1964 (October)		

Prices of Tokyo Olympic Games Tickets

Sports	Venue	Time of Day	Sec- tions	Ticket						All tickets		
				SPE- CIAL	I	II	III	IV	V	A	B	
OPENING CEREMONY	National Stadium	A	1	8,000	5,000	3,000	2,000	1,000	500			
ATHLETICS		MA	8	4,000	3,000	2,000	1,000	500		32,000	24,000	
ROWING	Toda Rowing Course	Heats	MA	4		1,000	500	300		6,000		
		Finals	A	1		2,000	1,000	500				
※ BASKET-BALL	National Gymnasium Annex	First round	MA	7		1,000	500	300		26,000	13,000	
			AN	7								
		Final round	A	4								
			N	4								
※ BOXING	Korakuen Ice Palace	Eliminations	A	11	2,000	1,000	500	300		47,000	24,000	
			N	11								
		Finals	N	1								3,000
CANOEING	Lake Sagami	MA	3		1,000	300						
CYCLING	Hachioji Velodrome	MA	5		1,000	500	300			5,000		
	Cycling Road Race Course	M	2		1,000	500	300					
FENCING	Waseda Memorial Hall	MAN	11		1,000	300				11,000		
FOOTBALL	National Stadium	League match	A	2		1,000	500	300		5,000	3,000	
		Finals	A	1	3,000	2,000	1,000	500				
	Prince Chichibu Memorial Football Field	League match	A	6		1,000	500	300		6,000	3,000	
	Komazawa Stadium			8					8,000	4,000		
	Mitsuzawa Football Field			7					7,000	3,500		
Omiya Football Field												
※ GYMNASTICS	Tokyo Metropolitan Gymnasium	Compulsory exercises	MA	2	3,000	2,000	1,000	500	300	26,000	16,000	
			N	2								
		Free exercises	MA	2								
			N	2								
Special competition	A	2										
※ WEIGHT-LIFTING	Shibuya Public Hall		MA	7		1,000	500	300		21,000		
			N	7		2,000	1,000	500	300			
HOCKEY	Komazawa First Hockey Ground	Eliminations	MA	11		1,000	500	300		13,000		
		Finals	A	1		2,000	1,000	500				
	Komazawa Second Hockey Ground	Eliminations	MA	10		1,000	500	300		10,000		
	Komazawa Third Hockey Ground	Eliminations	MA	9								
JUDO	Nippon Budokan Hall		A	4	3,000	2,000	1,000	500		12,000	8,000	
※ WRESTLING	Komazawa Gymnasium	Eliminations	A	8		1,000	500	300		26,000		
			N	6		2,000	1,000	500	300			
		Finals	N	2	3,000	2,000	1,000	500				
※ SWIMMING & DIVING	National Gymnasium		MA	8		2,000	1,000	500	300	40,000	24,000	
			N	8	3,000	2,000	1,000	500				
MODERN PENTATHLON	Asaka Nezu Park	Equestrian Sports	MA	1						6,000		
	Waseda Memorial Hall	Fencing	MA	1		1,000	300					
	Asaka Shooting Range	Shooting	MA	1								
	National Gymnasium	Swimming	A	1	(Same admission ticket could be used as for other swimming events)							
	Kemigawa Playing Grounds	Athletics	A	1								
EQUESTRIAN SPORTS	Karuizawa	Three day events	MA	3		1,000	300					
	Equestrian Park	Grand prix Dressage	MA	2		2,000	1,000	300				
	National Stadium	Grand prix Jumping	M	1		2,000	1,000	500	300			
SHOOTING	Asaka Shooting Range	Rifle	MA	5		100						
	Tokorozawa Clay Shooting Range	Clay Pigeon	MA	3		1,000	300					
※ VOLLEY-BALL	Komazawa Volley-ball Court		A	10		2,000	1,000	500	300	38,000	19,000	
			N	9								
	Yokohama Cultural Gymnasium		AN	10								
※ WATER-POLO	Metropolitan Indoor Swimming Pool		M	3		1,000	500	300				
			AN	7								
YACHTING	Sagami Bay	MA	7		1,000					7,000		
CLOSING CEREMONY	National Stadium	A	1	8,000	5,000	3,000	2,000	1,000	500			
DEMONSTRATIONS	BASE-BALL	Meiji Olympic Park Base-Ball Stadium	MA	1		1,000	500	300	200			
	BUDO	Nippon Budokan Hall	MA	1		1,000	300					

NOTE: 1 M...Morning, A...Afternoon, N...Night, 2. ※ mark indicates events which required separate tickets for each section of programme

Sales of Admission Tickets classified by Sports

Sports	No. of tickets	Total (Yen)
Opening Ceremony	63,294	163,761,500
Athletics	519,632	661,398,700
Rowing	25,870	13,539,800
Basket-Ball	66,621	37,707,100
Boxing	72,522	68,166,800
Canoeing	4,028	2,354,100
Cycling	19,399	9,532,100
Fencing	16,558	7,825,500
Football (included Games cancelled)	616,442	259,355,300
Gymnastics	50,642	57,687,600
Weight Lifting	21,350	13,026,600
Hockey	61,675	25,360,100
Judo	47,983	75,633,200
Wrestling	45,120	28,747,200
Swimming & Diving	154,350	218,472,400
Modern Pentathlon	4,438	2,248,400
Equestrian Sports	47,682	25,678,100
Shooting	10,087	2,668,200
Volley-Ball	83,423	54,493,100
Water-Polo	21,968	9,335,900
Yachting	2,581	2,581,000
Closing Ceremony	61,302	157,108,000
Sub-Total	2,016,967	1,896,680,700
Demonstration		
Base-ball	35,275	8,145,100
Budo	8,941	5,654,300
Sub-total	44,216	13,799,400
Total	2,061,183	1,910,480,100

Sales of Admission Tickets classified by Countries

No.	Country	No. of tickets	Total (Yen)
1	Argentina	84	139,600
2	Australia	15,712	30,481,200
3	Austria	100	125,000
4	Barbados	26	90,000
5	Belgium	161	512,500
6	Bolivia	71	127,300
7	Brazil	1,206	2,035,600
8	Cambodia	4	12,000
9	Canada	2,371	4,837,100
10	Ceylon	50	88,500
11	Chile	125	348,000
12	Colombia	250	382,000
13	Denmark	855	1,445,900
14	Netherlands Antilles	63	189,000
15	Ethiopia	18	51,000
16	Fiji	116	260,800
17	Finland	1,328	2,130,600
18	France	9,598	18,801,400

No.	Country	No. of tickets	Total (Yen)
19	Germany (East)	1,266	2,267,600
20	Germany (West)	9,019	19,893,400
21	Great Britain	5,763	11,994,900
22	Greece	130	242,200
23	Hong Kong	4,315	6,537,600
24	Hungary	1,195	1,640,000
25	India	220	522,900
26	Iran	237	512,200
27	Ireland	152	289,800
28	Israel	564	722,700
29	Italy	1,378	2,554,500
30	Jamaica	40	70,000
31	Japan { for Overseas for Domestic	63,226 1,826,270	74,495,400 1,501,008,100
32	Kenya	63	100,000
33	Korea	8,003	8,085,000
34	Lebanon	17	30,500
35	Libya	95	244,500
36	Malaya	288	430,600
37	Mexico	864	1,793,500
38	Netherlands	1,080	2,395,100
39	New Zealand	12,184	20,485,300
40	Nigeria	52	38,000
41	North Rhodesia	14	22,000
42	Norway	310	540,700
43	Pakistan	126	168,000
44	Peru	1,555	3,087,400
45	Philippines	4,889	8,640,300
46	Poland	250	125,000
47	Portugal	399	731,100
48	Rhodesia	169	244,700
49	Rumania	157	201,100
50	Singapore	545	902,100
51	South Africa	750	1,647,200
52	Spain	815	1,660,000
53	Sweden	2,237	4,585,300
54	Switzerland	2,413	5,749,700
55	Taiwan	1,906	3,083,300
56	Thailand	613	1,487,200
57	Uganda	32	32,800
58	U.S.A.	68,070	148,124,300
59	U.S.S.R.	7,048	10,366,000
60	Venezuela	22	53,000
61	Viet Nam	304	617,600
Total		2,061,183	1,910,480,100

(1US\$ = 360 Japanese Yen)

Sales amount classified by each Admission Tickets

	Price	Date	Tickets		Total (Yen)
			issued	sold	
Opening Ceremony	8,000	10 Oct. 14.00	5,127	5,094	40,752,000
	5,000		6,001	6,001	30,005,000
	3,000		12,966	12,942	38,826,000
	2,000		18,763	18,747	37,494,000
	1,000		13,833	13,818	13,818,000
	500		5,267	5,246	2,623,000
	200		989	989	197,800
	100		457	457	45,700
			63,403	63,294	163,761,500
Athletics	4,000	14 Oct. 10.00	3,862	3,680	14,720,000
	3,000		7,100	6,930	20,790,000
	2,000		13,808	13,587	27,174,000
	1,000		10,425	10,331	10,331,000
	500		12,489	12,471	6,235,500
	200		5,114	5,036	1,007,200
	100		12,713	12,638	1,263,800
				65,511	64,673
	4,000	15 Oct. 10.00	3,862	3,621	14,484,000
	3,000		7,100	6,925	20,775,000
	2,000		13,808	13,642	27,284,000
	1,000		10,425	10,359	10,359,000
	500		12,489	12,479	6,239,500
	200		6,728	6,208	1,241,600
	100		11,099	10,946	1,094,600
				65,511	64,180
	4,000	16 Oct. 10.00	3,862	3,638	14,552,000
	3,000		7,100	7,034	21,102,000
	2,000		13,808	13,740	27,480,000
	1,000		10,425	10,405	10,405,000
	500		12,489	12,486	6,243,000
	200		8,244	8,014	1,602,800
	100		9,583	9,521	952,100
				65,511	64,838
4,000	17 Oct. 10.00	3,862	3,762	15,048,000	
3,000		7,100	7,008	21,024,000	
2,000		13,808	13,796	27,592,000	
1,000		10,425	10,423	10,423,000	
500		12,489	12,489	6,244,500	
200		7,270	7,109	1,421,800	
100		10,557	10,557	1,055,700	
			65,511	65,144	82,809,000
4,000	18 Oct. 10.00	3,862	3,845	15,380,000	
3,000		7,100	7,091	21,273,000	
2,000		13,808	13,806	27,612,000	
1,000		10,425	10,420	10,420,000	
500		12,489	12,486	6,243,000	
200		5,909	5,679	1,135,800	
100		11,918	11,856	1,185,600	
			65,511	65,183	83,249,400

	Price	Date	Tickets		Total (Yen)	
			issued	sold		
Athletics	4,000	19 Oct. 10.00	3,862	3,853	15,412,000	
	3,000		7,100	7,053	21,159,000	
	2,000		13,808	13,806	27,612,000	
	1,000		10,425	10,423	10,423,000	
	500		12,489	12,481	6,240,500	
	200		7,800	7,570	1,514,000	
	100		10,027	10,024	1,002,400	
				65,511	65,210	83,362,900
	4,000	20 Oct. 9.00	3,862	3,725	14,900,000	
	3,000		7,100	7,092	21,276,000	
	2,000		13,808	13,806	27,612,000	
	1,000		10,425	10,423	10,423,000	
	500		12,489	12,484	6,242,000	
	200		7,890	7,684	1,536,800	
	100		9,937	9,937	993,700	
				65,511	65,151	82,983,500
	4,000	21 Oct. 13.00	3,862	3,861	15,444,000	
	3,000		7,100	7,099	21,297,000	
	2,000		13,808	13,805	27,610,000	
	1,000		10,425	10,425	10,425,000	
	500		12,489	12,486	6,243,000	
	200		9,029	8,811	1,762,200	
	100		8,798	8,766	876,600	
				65,511	65,253	83,657,800
			524,088	519,632	661,398,700	
Rowing	1,000	11 Oct. 10.00	1,243	1,191	1,191,000	
	500		1,663	1,583	791,500	
	300		2,226	1,702	510,600	
	200		853	600	120,000	
	100		1,783	1,530	153,000	
				7,768	6,606	2,766,100
	1,000		12 Oct. 10.00	1,243	1,200	1,200,000
	500			1,663	1,551	775,500
	300	2,226		1,325	397,500	
	200	1,636		1,403	280,600	
	100	1,000		827	82,700	
				7,768	6,306	2,736,300
	1,000	13 Oct. 10.00		1,243	1,218	1,218,000
	500			1,663	1,594	797,000
	300		2,226	1,287	386,100	
	200		1,386	1,133	226,600	
100	1,250		997	99,700		
			7,768	6,229	2,727,400	
1,000	14 Oct. 10.00		1,243	70	70,000	
500			1,663	73	36,500	
300		2,226	79	23,700		
200		475	50	10,000		
			5,607	272	140,200	

	Price	Date	Tickets		Total (Yen)
			issued	sold	
Rowing	2,000	15 Oct. 14.00	1,243	1,239	2,478,000
	1,000		1,663	1,653	1,653,000
	500		2,226	1,411	705,500
	200		1,432	1,179	235,800
	100		1,204	975	97,500
			7,768	6,457	5,169,800
	36,679	25,870	13,539,800		
Basket-Ball	1,000	11 Oct. 9.00	756	748	748,000
	500		783	755	377,500
	300		777	743	222,900
	200		181	166	33,200
	100		616	616	61,600
			3,113	3,028	1,443,200
	1,000	16.00	756	752	752,000
	500		783	751	375,500
	300		777	718	215,400
	200		631	631	126,200
	100		166	151	15,100
			3,113	3,003	1,484,200
	1,000	12 Oct. 9.00	756	745	745,000
	500		783	732	366,000
	300		777	720	216,000
	200		75	60	12,000
	100		722	722	72,200
			3,113	2,979	1,411,200
	1,000	16.00	756	732	732,000
	500		783	722	361,000
	300		777	725	217,500
	200		772	757	151,400
	100		25	25	2,500
			3,113	2,961	1,464,400
1,000	13 Oct. 9.00	756	747	747,000	
500		783	736	368,000	
300		777	713	213,900	
200		437	420	84,000	
100		354	337	33,700	
		3,107	2,953	1,446,600	
1,000	16.00	756	728	728,000	
500		783	737	368,500	
300		777	730	219,000	
200		782	782	156,400	
100		15	0	0	
		3,113	2,977	1,471,900	
1,000	14 Oct. 9.00	756	700	700,000	
500		783	732	366,000	
300		777	699	209,700	

	Price	Date	Tickets		Total (Yen)	
			issued	sold		
Basket-Ball	200	16.00	255	240	48,000	
	100		542	517	51,700	
			3,113	2,888	1,375,400	
	1,000		756	723	723,000	
	500		783	742	371,000	
	300		777	700	210,000	
	200		718	694	138,800	
	100		78	63	6,300	
			3,112	2,922	1,449,100	
	1,000		16 Oct. 9.00	756	734	734,000
	500			783	735	367,500
	300			777	731	219,300
	200	225		210	42,000	
	100	572		572	57,200	
		3,113		2,982	1,420,000	
	1,000	16.00	756	727	727,000	
	500		783	759	379,500	
	300		777	748	224,400	
	200		732	732	146,400	
	100		65	50	5,000	
			3,113	3,016	1,482,300	
	1,000	17 Oct. 9.00	756	737	737,000	
	500		783	749	374,500	
	300		777	744	223,200	
200	604		589	117,800		
100	193		193	19,300		
	3,113		3,012	1,471,800		
1,000	16.00	756	743	743,000		
500		783	757	378,500		
300		777	747	224,100		
200		655	655	131,000		
100		141	126	12,600		
		3,112	3,028	1,489,200		
1,000	18 Oct. 9.00	756	754	754,000		
500		783	783	391,500		
300		777	770	231,000		
200		412	397	79,400		
100		385	385	38,500		
		3,113	3,089	1,494,400		
1,000	16.00	756	755	755,000		
500		783	783	391,500		
300		777	777	233,100		
200		782	782	156,400		
100		15	0	0		
		3,113	3,097	1,536,000		

	Price	Date	Tickets		Total (Yen)
			issued	sold	
Basket-Ball	1,000	20 Oct. 14.00	756	755	755,000
	500		783	780	390,000
	300		777	769	230,700
	200		415	415	83,000
	100		382	367	36,700
			3,113	3,086	1,495,400
	2,000	18.30	756	751	1,502,000
	1,000		783	782	782,000
	500		777	776	388,000
	200		772	757	151,400
	100		25	25	2,500
			3,113	3,091	2,825,900
	1,000	21 Oct. 14.00	756	753	753,000
	500		783	783	391,500
	300		777	768	230,400
	200		252	252	50,400
	100		545	530	53,000
			3,113	3,086	1,478,300
	2,000	18.30	756	755	1,510,000
	1,000		783	783	783,000
	500		777	777	388,500
	200		772	757	151,400
	100		25	25	2,500
			3,113	3,097	2,835,400
	1,000	22 Oct. 14.00	756	756	756,000
	500		783	781	390,500
	300		777	767	230,100
	200		282	257	51,400
	100		515	500	50,000
			3,113	3,061	1,478,000
	2,000	18.00	756	756	1,512,000
	1,000		783	783	783,000
	500		777	777	388,500
	200		782	757	151,400
	100		15	0	0
			3,113	3,073	2,834,900
	1,000	23 Oct. 14.00	756	753	753,000
	500		783	782	391,000
	300		777	777	233,100
	200		228	228	45,600
100	569		554	55,400	
		3,113	3,094	1,478,100	
2,000	18.30	759	759	1,518,000	
1,000		783	782	782,000	
500		777	775	387,500	
200		772	757	151,400	

	Price	Date	Tickets		Total (Yen)
			issued	sold	
Basket-Ball	100		25	25	2,500
			3,116	3,098	2,841,400
			68,481	66,621	37,707,100
Boxing	2,000	11 Oct. 14.00	808	644	1,288,000
	1,000		1,088	1,025	1,025,000
	500		455	377	188,500
	300		373	358	107,400
	200		340	286	57,200
	100	402	349	34,900	
			3,466	3,039	2,701,000
	2,000	19.00	807	604	1,208,000
	1,000		1,089	1,030	1,030,000
	500		455	406	203,000
	300		383	359	107,700
	200		689	635	127,000
	100	53	0	0	
			3,476	3,034	2,675,700
	2,000	12 Oct. 14.00	806	594	1,188,000
	1,000		1,090	965	965,000
	500		455	388	194,000
	300		378	337	101,100
	200		446	392	78,400
	100	296	243	24,300	
			3,471	2,919	2,550,800
	2,000	19.00	808	599	1,198,000
	1,000		1,088	924	924,000
	500		455	359	179,500
	300		383	285	85,500
	200		589	535	107,000
	100	153	100	10,000	
			3,476	2,802	2,504,000
	2,000	13 Oct. 14.00	803	584	1,168,000
	1,000		1,093	934	934,000
	500		455	408	204,000
	300		373	361	108,300
	200		154	100	20,000
	100	588	535	53,500	
			3,466	2,922	2,487,800
	2,000	19.00	808	537	1,074,000
	1,000		1,088	917	917,000
	500		455	414	207,000
	300		378	353	105,900
	200		689	655	131,000
100	53	0	0		
		3,471	2,876	2,434,900	
2,000	14 Oct. 14.00	808	471	942,000	

	Price	Date	Tickets		Total (Yen)
			issued	sold	
Boxing	1,000	19.00	1,108	1,008	1,008,000
	500		455	395	197,500
	300		373	356	106,800
	200		385	331	66,200
	100		357	304	30,400
			3,486	2,865	2,350,900
	2,000		808	557	1,114,000
	1,000		1,108	1,030	1,030,000
	500		455	403	201,500
	300		383	358	107,400
	200	609	555	111,000	
	100	133	80	8,000	
		3,496	2,983	2,571,900	
	2,000	15 Oct. 14.00	808	574	1,148,000
	1,000	1,108	1,009	1,009,000	
	500	455	390	195,000	
	300	368	351	105,300	
	200	519	465	93,000	
	100	223	170	17,000	
		3,481	2,959	2,567,300	
	2,000	19.00	808	644	1,288,000
	1,000	1,108	1,032	1,032,000	
	500	455	384	192,000	
	300	378	352	105,600	
	200	689	635	127,000	
	100	53	0	0	
		3,491	3,047	2,744,600	
	2,000	16 Oct. 14.00	808	717	1,434,000
	1,000	1,108	1,060	1,060,000	
	500	455	424	212,000	
	300	373	366	109,800	
	200	462	408	81,600	
	100	280	227	22,700	
		3,486	3,202	2,920,100	
	2,000	19.00	808	723	1,446,000
	1,000	1,108	1,083	1,083,000	
500	455	452	226,000		
300	383	363	108,900		
200	689	635	127,000		
100	53	0	0		
	3,496	3,256	2,990,900		
2,000	17 Oct. 14.00	810	745	1,490,000	
1,000	1,106	1,072	1,072,000		
500	455	430	215,000		
300	373	364	109,200		
200	410	356	71,200		
100	332	279	27,900		

	Price	Date	Tickets		Total (Yen)	
			issued	sold		
Boxing		19.00	3,486	3,246	2,985,300	
	2,000		810	744	1,488,000	
	1,000		1,106	1,068	1,068,000	
	500		455	439	219,500	
	300		383	370	111,000	
	200		689	635	127,000	
	100		53	0	0	
			3,496	3,256	3,013,500	
	2,000		18 Oct. 14.00	808	743	1,486,000
	1,000		1,108	1,090	1,090,000	
	500	455	454	227,000		
	300	373	372	111,600		
	200	550	496	99,200		
	100	192	139	13,900		
		3,486	3,294	3,027,700		
	2,000	19.00	810	767	1,534,000	
	1,000	1,106	1,092	1,092,000		
	500	455	455	227,500		
	300	378	378	113,400		
	200	689	635	127,000		
	100	53	0	0		
		3,491	3,327	3,093,900		
	2,000	19 Oct. 14.00	810	754	1,508,000	
	1,000	1,106	1,083	1,083,000		
	500	455	445	222,500		
	300	373	371	111,300		
	200	476	422	84,400		
	100	266	213	21,300		
		3,486	3,288	3,030,500		
	2,000	19.00	808	788	1,576,000	
	1,000	1,108	1,095	1,095,000		
	500	455	453	226,500		
	300	378	378	113,400		
	200	689	635	127,000		
	100	53	0	0		
		3,491	3,349	3,137,900		
2,000	20 Oct. 14.00	808	781	1,562,000		
1,000	1,108	1,095	1,095,000			
500	855	850	425,000			
300	635	623	186,900			
	3,406	3,349	3,268,900			
2,000	19.00	808	792	1,584,000		
1,000	1,108	1,095	1,095,000			
500	455	453	226,500			
300	378	378	113,400			
200	689	635	127,000			
100	53	0	0			

	Price	Date	Tickets		Total (Yen)
			issued	sold	
Boxing			3,491	3,353	3,145,900
	2,000	21 Oct. 14.00	808	795	1,590,000
	1,000		1,108	1,093	1,093,000
	500		855	848	424,000
	300		635	628	188,400
			3,406	3,364	3,295,400
	2,000	19.00	818	805	1,610,000
	1,000		1,098	1,091	1,091,000
	500		455	454	227,000
	300		373	373	111,900
	200		689	635	127,000
	100		53	0	0
			3,486	3,358	3,166,900
	3,000	23 Oct. 19.00	839	832	2,496,000
	2,000		1,113	1,108	2,216,000
	1,000		465	465	465,000
	500		397	394	197,000
	200		689	635	127,000
	100		53	0	0
		3,556	3,434	5,501,000	
	80,043	72,522	68,166,800		
Canoeing	1,000	20 Oct. 10.00	640	602	602,000
	300		440	438	131,400
	200		187	187	37,400
	100		103	103	10,300
		1,370	1,330	781,100	
	1,000	21 Oct. 10.00	640	624	624,000
	300		440	440	132,000
	100		290	290	29,000
		1,370	1,354	785,000	
	1,000	22 Oct. 14.00	640	614	614,000
	300		440	440	132,000
	200		130	130	26,000
	100		160	160	16,000
			1,370	1,344	788,000
	4,110		4,028	2,354,100	
Cycling (Piste)	1,000	16 Oct. 10.00	731	684	684,000
	500		1,083	1,051	525,500
	300		670	646	193,800
	200		93	59	11,800
	100		605	571	57,100
		3,182	3,011	1,472,200	
	1,000	17 Oct. 10.00	731	695	695,000
	500		1,083	1,050	525,000
	300		670	652	195,600

	Price	Date	Tickets		Total (Yen)
			issued	sold	
Cycling (Piste)	200		272	238	47,600
	100		426	392	39,200
			3,182	3,027	1,502,400
	1,000	18 Oct. 10.00	731	696	696,000
	500		1,083	1,054	527,000
	300		670	648	194,400
	200		358	224	44,800
	100		340	306	30,600
		3,182	2,928	1,492,800	
	1,000	19 Oct. 10.00	731	693	693,000
	500		1,083	1,060	530,000
	300		670	653	195,900
	200		573	564	112,800
	100		125	91	9,100
		3,182	3,061	1,540,800	
	1,000	20 Oct. 14.00	731	699	699,000
	500		1,083	1,040	520,000
	300		670	647	194,100
	200		109	75	15,000
	100		589	555	55,500
	3,182	3,016	1,483,600		
	15,910	15,043	7,491,800		
Cycling (Road)	1,000	14 Oct. 10.00	492	442	442,000
	500		598	572	286,000
	300		731	679	203,700
	200		199	188	37,600
	100		345	285	28,500
		2,365	2,166	997,800	
	1,000	22 Oct. 10.00	492	472	472,000
	500		598	595	297,500
	300		731	694	208,200
	200		251	219	43,800
	100		293	210	21,000
		2,365	2,190	1,042,500	
		4,730	4,356	2,040,300	
	Fencing	1,000	13 Oct. 8.30	504	484
300		475		448	134,400
200		30		0	0
100		582		552	55,200
		1,591		1,484	673,600
1,000		14 Oct. 8.30	504	491	491,000
300			475	446	133,800
200			422	392	78,400
100			190	160	16,000
			1,591	1,489	719,200

	Price	Date	Tickets		Total (Yen)
			issued	sold	
Fencing	1,000	15 Oct. 8.30	504	476	476,000
	300		475	457	137,100
	200		486	456	91,200
	100		126	96	9,600
			1,591	1,485	713,900
	1,000	16 Oct. 8.30	504	478	478,000
	300		475	456	136,800
	200		503	473	94,600
	100		112	91	9,100
			1,594	1,498	718,500
	1,000	17 Oct. 8.30	504	494	494,000
	300		475	457	137,100
	200		30	0	0
	100		582	552	55,200
			1,591	1,503	686,300
	1,000	18 Oct. 8.30	504	494	494,000
	300		475	465	139,500
	200		329	299	59,800
	100		283	253	25,300
			1,591	1,511	718,600
	1,000	19 Oct. 8.30	504	494	494,000
	300		475	463	138,900
	200		182	152	30,400
	100		430	400	40,000
			1,591	1,509	703,300
	1,000	20 Oct. 8.30	504	490	490,000
	300		475	475	142,500
	200		431	401	80,200
100	181		151	15,100	
	1,591		1,517	727,800	
1,000	21 Oct. 8.30	504	494	494,000	
300		475	475	142,500	
200		220	190	38,000	
100		392	362	36,200	
		1,591	1,521	710,700	
1,000	22 Oct. 8.30	504	494	494,000	
300		475	473	141,900	
200		386	356	71,200	
100		226	196	19,600	
		1,591	1,519	726,700	
1,000	23 Oct. 8.30	504	499	499,000	
300		475	471	141,300	
200		344	314	62,800	
100		268	238	23,800	
		1,591	1,522	726,900	
			17,504	16,558	7,825,500

	Price	Date	Tickets		Total (Yen)
			issued	sold	
Football (National Stadium)	1,000	11 Oct. 14.00	10,088	9,780	9,780,000
	500		10,305	10,168	5,084,000
	300		14,212	14,139	4,241,700
	200		7,379	7,333	1,466,600
	100		24,419	24,373	2,437,300
		66,403	65,793	23,009,600	
	1,000	12 Oct. 14.00 (Game cancelled)	10,088	9,484	9,484,000
	500		10,305	9,733	4,866,500
	300		14,212	12,535	3,760,500
	200		9,569	9,266	1,853,200
	100		22,406	21,833	2,183,300
		66,580	62,851	22,147,500	
	3,000	23 Oct. 12.00	4,430	4,421	13,263,000
	2,000		7,242	7,228	14,456,000
	1,000		11,205	11,205	11,205,000
	500		14,233	14,233	7,116,500
	200		14,645	14,517	2,903,400
	100	14,133	14,006	1,400,600	
		65,888	65,610	50,344,500	
		198,871	194,254	95,501,600	
	1,000	13 Oct. 14.00	3,759	3,590	3,590,000
	500		2,739	2,625	1,312,500
	300		4,905	4,843	1,452,900
	200		1,753	1,708	341,600
	100		3,237	3,172	317,200
		16,393	15,938	7,014,200	
	1,000	14 Oct. 14.00	3,759	3,547	3,547,000
	500		2,739	2,628	1,314,000
300	4,905		4,848	1,454,400	
200	2,195		2,150	430,000	
100	2,795		2,730	273,000	
	16,393	15,903	7,018,400		
1,000	15 Oct. 14.00 (Game cancelled)	3,759	3,451	3,451,000	
500		2,739	2,520	1,260,000	
300		4,905	4,669	1,400,700	
200		2,347	2,302	460,400	
100		2,643	2,578	257,800	
	16,393	15,520	6,829,900		
1,000	16 Oct. 14.00	3,759	3,684	3,684,000	
500		2,739	2,648	1,324,000	
300		4,905	4,827	1,448,100	
200		1,516	1,471	294,200	
100		3,474	3,409	340,900	
	16,393	16,039	7,091,200		
1,000	18 Oct. 14.00	3,759	3,699	3,699,000	
500		2,739	2,712	1,356,000	

	Price	Date	Tickets		Total (Yen)
			issued	sold	
Football (Prince Chichibu Memorial Football Field)	300		4,921	4,876	1,462,800
	200		1,212	967	193,400
	100		3,758	3,513	351,300
			16,389	15,767	7,062,500
	1,000	20 Oct. 14.00	3,759	3,690	3,690,000
	500		2,739	2,677	1,338,500
	300		4,911	4,882	1,464,600
	200		2,565	2,565	513,000
	100		2,405	2,365	236,500
			16,379	16,179	7,242,600
	98,340		95,346	42,258,800	
Football (Komazawa Stadium)	1,000	11 Oct. 14.00 (Game cancelled)	3,619	3,343	3,343,000
	500		3,948	3,757	1,878,500
	300		5,481	5,320	1,596,000
	200		1,382	1,375	275,000
	100		5,032	5,021	502,100
		19,462	18,816	7,594,600	
	1,000	12 Oct. 14.00	3,619	2,998	2,998,000
	500		3,948	3,294	1,647,000
	300		5,481	3,757	1,127,100
	200		2,311	2,304	460,800
	100		4,103	4,097	409,700
		19,462	16,450	6,642,600	
	1,000	13 Oct. 14.00	3,619	3,422	3,422,000
	500		3,948	3,765	1,882,500
	300		5,481	5,382	1,614,600
	200		3,366	3,359	671,800
	100		3,048	3,042	304,200
		19,462	18,970	7,895,100	
	1,000	14 Oct. 14.00	3,619	3,518	3,518,000
	500		3,948	3,855	1,927,500
	300		5,481	5,475	1,642,500
	200		2,610	2,471	494,200
	100		3,836	3,730	373,000
		19,494	19,049	7,955,200	
1,000	15 Oct. 14.00	3,619	3,600	3,600,000	
500		3,948	3,882	1,941,000	
300		5,481	5,433	1,629,900	
200		1,244	1,237	247,400	
100		5,170	5,164	516,400	
	19,462	19,316	7,934,700		
1,000	16 Oct. 14.00	3,619	3,597	3,597,000	
500		3,948	3,926	1,963,000	
300		5,481	5,430	1,629,000	
200		3,559	3,552	710,400	
100		2,855	2,849	284,900	

	Price	Date	Tickets		Total (Yen)
			issued	sold	
Football (Komazawa Stadium)			19,462	19,354	8,184,300
	1,000	18 Oct. 14.00	3,659	3,641	3,641,000
	500		3,948	3,940	1,970,000
	300		5,551	5,545	1,663,500
	200		1,402	1,005	201,000
	100		5,216	4,809	480,900
		19,776	18,940	7,956,400	
	1,000	20 Oct. 14.00	3,619	3,613	3,613,000
	500		3,948	3,945	1,972,500
	300		5,481	5,476	1,642,800
200	2,622		2,615	523,000	
100	3,792		3,786	378,600	
	19,462	19,435	8,129,900		
			156,042	150,330	62,292,800
Football (Mitsuzawa Football Field)	1,000	11 Oct. 14.00	1,720	1,581	1,581,000
	500		1,846	1,734	867,000
	300		4,450	4,364	1,309,200
	200		2,544	2,514	502,800
	100		2,478	2,478	247,800
		13,038	12,671	4,507,800	
	1,000	12 Oct. 14.00	1,720	1,372	1,372,000
	500		1,846	1,724	862,000
	300		4,450	4,367	1,310,100
	200		1,172	1,172	234,400
	100		3,850	3,817	381,700
		13,038	12,452	4,160,200	
	1,000	13 Oct. 14.00	1,720	1,524	1,524,000
	500		1,846	1,755	877,500
	300		4,450	4,404	1,321,200
	200		597	597	119,400
	100		4,425	4,395	439,500
		13,038	12,675	4,281,600	
	1,000	14 Oct. 14.00	1,720	1,581	1,581,000
	500		1,846	1,742	871,000
	300		4,450	4,397	1,319,100
	200		1,089	1,057	211,400
	100		3,932	3,895	389,500
		13,037	12,672	4,372,000	
1,000	15 Oct. 14.00	1,720	1,652	1,652,000	
500		1,846	1,783	891,500	
300		4,450	4,427	1,328,100	
200		951	918	183,600	
100		4,072	4,034	403,400	
	13,039	12,814	4,458,600		
1,000	16 Oct. 14.00	1,720	1,292	1,292,000	
500		1,846	1,589	794,500	

	Price	Date	Tickets		Total (Yen)
			issued	sold	
Football (Mitsuzawa Football Field)	300	(Game cancelled)	4,450	3,598	1,079,400
	200		2,025	1,995	399,000
	100		2,997	2,997	299,700
			13,038	11,471	3,864,600
	1,000	18 Oct. 14.00	1,720	1,667	1,667,000
	500		1,846	1,805	902,500
	300		4,450	4,417	1,325,100
	200		1,972	1,939	387,800
	100		3,051	3,013	301,300
			13,039	12,841	4,583,700
	91,267		87,596	30,228,500	
Football (Omiya Football Field)	1,000	11 Oct. 14.00	1,267	1,196	1,196,000
	500		2,020	1,826	913,000
	300		4,946	4,914	1,474,200
	200		780	724	144,800
	100		4,378	4,272	427,200
		13,391	12,932	4,155,200	
	1,000	12 Oct. 14.00	1,267	1,195	1,195,000
	500		2,020	1,825	912,500
	300		4,926	4,890	1,467,000
	200		106	87	17,400
	100		5,052	4,946	494,600
		13,371	12,943	4,086,500	
	1,000	13 Oct. 14.00 (Game cancelled)	1,267	1,169	1,169,000
	500		2,020	1,832	916,000
	300		4,931	4,866	1,459,800
	200		1,033	977	195,400
	100		4,125	4,019	401,900
		13,376	12,863	4,142,100	
	1,000	14 Oct. 14.00 (Game cancelled)	1,266	921	921,000
	500		2,020	1,179	589,500
	300		4,930	3,813	1,143,900
	200		1,907	1,853	370,600
	100		3,251	3,145	314,500
		13,374	10,911	3,339,500	
	1,000	15 Oct. 14.00	1,267	1,214	1,214,000
	500		2,020	1,929	964,500
	300		4,948	4,937	1,481,100
	200		1,730	1,624	324,800
100	3,428		3,322	332,200	
	13,393	13,026	4,316,600		
1,000	16 Oct. 14.00	1,267	1,234	1,234,000	
500		2,020	2,012	1,006,000	
300		4,948	4,928	1,478,400	
200		1,805	1,699	339,800	
100		3,353	3,247	324,700	

	Price	Date	Tickets		Total (Yen)
			issued	sold	
Football (Omiya Football Field)			13,393	13,120	4,382,900
	1,000	18 Oct. 14.00	1,267	1,241	1,241,000
	500		2,020	2,012	1,006,000
	300		4,932	4,922	1,476,600
	200		4,432	4,326	865,200
	100		726	620	62,000
			13,377	13,121	4,650,800
		93,675	88,916	29,073,600	
		638,195	616,442	259,355,300	
	Gymnastics	2,000	18 Oct. 8.00	774	770
1,000		1,274		1,272	1,272,000
500		1,414		1,406	703,000
300		467		466	139,800
200		413		341	68,200
100		851	780	78,000	
		5,193	5,035	3,801,000	
2,000		17.00	774	771	1,542,000
1,000			1,274	1,274	1,274,000
500			1,891	1,888	944,000
300			578	578	173,400
200			573	535	107,000
100		53	16	1,600	
		5,143	5,062	4,042,000	
2,000		19 Oct. 8.00	774	768	1,536,000
1,000			1,289	1,274	1,274,000
500			1,427	1,413	706,500
300			473	467	140,100
200			315	259	51,800
100		949	890	89,000	
		5,227	5,071	3,797,400	
2,000		7.00	774	774	1,548,000
1,000			1,289	1,274	1,274,000
500			1,910	1,890	945,000
300			603	573	171,900
200			589	551	110,200
100		37	0	0	
		5,202	5,062	4,049,100	
3,000	20 Oct. 8.00	774	772	2,316,000	
2,000		1,289	1,274	2,548,000	
1,000		1,427	1,413	1,413,000	
500		473	467	233,500	
200		649	577	115,400	
100	615	556	55,600		
	5,227	5,059	6,681,500		
3,000	17.00	774	772	2,316,000	
2,000		1,289	1,273	2,546,000	

	Price	Date	Tickets		Total (Yen)	
			issued	sold		
Gymnastics	1,000		1,910	1,897	1,897,000	
	500		603	584	292,000	
	200		522	484	96,800	
	100		104	67	6,700	
			5,202	5,077	7,154,500	
	3,000		21 Oct. 8.00	774	773	2,319,000
	2,000			1,289	1,275	2,550,000
	1,000			1,427	1,414	1,414,000
	500			473	465	232,500
	200			451	379	75,800
	100	813		737	73,700	
		5,227		5,043	6,665,000	
	3,000	17.00		774	774	2,322,000
	2,000		1,289	1,278	2,556,000	
	1,000		1,910	1,893	1,893,000	
	500		603	586	293,000	
	200		485	447	89,400	
	100		141	114	11,400	
			5,202	5,092	7,164,800	
	3,000		22 Oct. 17.00	774	774	2,322,000
	2,000	1,289		1,275	2,550,000	
	1,000	1,910		1,899	1,899,000	
	500	603		578	289,000	
	200	589		543	108,600	
100	37	0		0		
	5,202	5,069		7,168,600		
3,000	23 Oct. 18.00	774		774	2,322,000	
2,000		1,289	1,274	2,548,000		
1,000		1,910	1,894	1,894,000		
500		603	579	289,500		
200		589	551	110,200		
100		37	0	0		
		5,202	5,072	7,163,700		
		52,027	50,642	57,687,600		
Weight-Lifting	1,000	11 Oct. 10.00	313	278	278,000	
	500		414	382	191,000	
	300		244	225	67,500	
	200		718	655	131,000	
			1,689	1,540	667,500	
	2,000		16.00	313	268	536,000
	1,000	414	389	389,000		
	500	244	227	113,500		
	300	420	398	119,400		
	200	272	229	45,800		
		1,663	1,511	1,203,700		
	1,000	12 Oct. 10.00	313	286	286,000	

	Price	Date	Tickets		Total (Yen)	
			issued	sold		
Weight-Lifting	500		414	377	188,500	
	300		244	233	69,900	
	200		718	655	131,000	
			1,689	1,551	675,400	
	2,000		16.00	313	254	508,000
	1,000			414	387	387,000
	500			244	225	112,500
	300			420	404	121,200
	200			272	229	45,800
				1,663	1,499	1,174,500
	1,000	13 Oct. 10.00		313	266	266,000
	500			414	370	185,000
	300		244	224	67,200	
	200		718	655	131,000	
			1,689	1,515	649,200	
	2,000		16.00	313	254	508,000
	1,000	414		381	381,000	
	500	244		228	114,000	
	300	420		397	119,100	
	200	272		229	45,800	
		1,663		1,489	1,167,900	
	1,000	14 Oct. 10.00		313	270	270,000
	500			414	365	182,500
	300		244	221	66,300	
	200		718	655	131,000	
			1,689	1,511	649,800	
	2,000		16.00	313	260	520,000
	1,000	414		385	385,000	
	500	244		225	112,500	
	300	420		398	119,400	
	200	272		229	45,800	
		1,663		1,497	1,182,700	
1,000	16 Oct. 10.00	313		266	266,000	
500		414		374	187,000	
300		244	225	67,500		
200		718	655	131,000		
		1,689	1,520	651,500		
2,000		16.00	313	264	528,000	
1,000	414		373	373,000		
500	244		230	115,000		
300	420		398	119,400		
200	272		229	45,800		
	1,663		1,494	1,181,200		
1,000	17 Oct. 10.00		313	266	266,000	
500			414	394	197,000	
300		244	220	66,000		

	Price	Date	Tickets		Total (Yen)		
			issued	sold			
Weight-Lifting	200		718	655	131,000		
			1,689	1,535	660,000		
	2,000 1,000 500 300 200	16.00	313	268	536,000		
			414	392	392,000		
			244	226	113,000		
			420	406	121,800		
			272	229	45,800		
			1,663	1,521	1,208,600		
	1,000 500 300 200	18 Oct. 10.00	313	283	283,000		
			414	405	202,500		
			244	244	73,200		
			724	724	144,800		
			1,695	1,656	703,500		
	2,000 1,000 500 300 200	16.00	313	281	562,000		
			414	411	411,000		
			244	242	121,000		
			420	417	125,100		
			272	160	32,000		
					1,663	1,511	1,251,100
					23,470	21,350	13,026,600
Hockey (Komazawa 1st Hockey Ground)			1,000 500 300 200 100	11 Oct. 10.00	232	211	211,000
	420	389			194,500		
	398	354			106,200		
	410	405			81,000		
	166	161			16,100		
			1,626	1,520	608,800		
	1,000 500 300 200 100	12 Oct. 10.00	232	208	208,000		
			420	357	178,500		
			398	326	97,800		
			5	0	0		
			571	566	56,600		
			1,626	1,457	540,900		
	1,000 500 300 200 100	13 Oct. 11.40	232	205	205,000		
			420	333	166,500		
			398	265	79,500		
			309	304	60,800		
			267	262	26,200		
			1,626	1,369	538,000		
	1,000 500 300 200 100	14 Oct. 11.40	232	203	203,000		
			420	321	160,500		
398			276	82,800			
162			157	31,400			
414			409	40,900			
		1,626	1,366	518,600			
1,000 500	15 Oct. 10.00	232	201	201,000			
		420	361	180,500			

	Price	Date	Tickets		Total (Yen)
			issued	sold	
Hockey (Komazawa 1st Hockey Ground)	300 200 100		398	338	101,400
			55	50	10,000
			521	516	51,600
			1,626	1,466	544,500
	1,000 500 300 200 100	16 Oct. 11.40	232	199	199,000
			420	368	184,000
			398	335	100,500
			462	457	91,400
			114	109	10,900
			1,626	1,468	585,800
	1,000 500 300 200 100	17 Oct. 11.40	232	203	203,000
			420	393	196,500
			398	332	99,600
			116	111	22,200
			460	455	45,500
			1,626	1,494	566,800
	1,000 500 300 200 100	18 Oct. 10.00	232	204	204,000
			420	408	204,000
			398	345	103,500
			30	25	5,000
546			541	54,100	
		1,626	1,523	570,600	
1,000 500 300 200 100	19 Oct. 10.00	232	211	211,000	
		420	411	205,500	
		398	347	104,100	
		451	446	89,200	
		125	120	12,000	
		1,626	1,535	621,800	
1,000 500 300 200 100	21 Oct. 12.15	232	226	226,000	
		420	420	210,000	
		398	397	119,100	
		314	309	61,800	
		262	257	25,700	
		1,626	1,609	642,600	
1,000 500 300 200 100	22 Oct. 13.55	235	235	235,000	
		420	413	206,500	
		398	398	119,400	
		5	0	0	
		571	566	56,600	
		1,629	1,612	617,500	
2,000 1,000 500 200 100	23 Oct. 12.15	232	232	464,000	
		420	419	419,000	
		398	398	199,000	
		421	416	83,200	
		155	150	15,000	
		1,626	1,615	1,180,200	

	Price	Date	Tickets		Total (Yen)
			issued	sold	
			19,515	18,034	7,536,100
Hockey (Komazawa 2nd Hockey Ground)	1,000	11 Oct. 10.00	603	516	516,000
	500		604	537	268,500
	300		786	725	217,500
	200		55	50	10,000
	100		869	864	86,400
			2,917	2,692	1,098,400
	1,000	12 Oct. 10.00	603	502	502,000
	500		604	521	260,500
	300		786	682	204,600
	200		255	250	50,000
	100		669	645	64,500
			2,917	2,600	1,081,600
	1,000	13 Oct. 10.00	603	514	514,000
	500		604	536	268,000
	300		786	723	216,900
	200		480	475	95,000
	100		444	439	43,900
			2,917	2,687	1,137,800
	1,000	14 Oct. 10.00	603	501	501,000
	500		604	530	265,000
	300		786	717	215,100
	200		482	477	95,400
	100		442	437	43,700
			2,917	2,662	1,120,200
	1,000	15 Oct. 10.00	603	553	553,000
	500		604	580	290,000
	300		786	767	230,100
	200		91	86	17,200
	100		833	828	82,800
			2,917	2,814	1,173,100
	1,000	16 Oct. 10.00	603	543	543,000
	500		604	574	287,000
	300		786	759	227,700
	200		68	63	12,600
	100		856	851	85,100
			2,917	2,790	1,155,400
1,000	17 Oct. 10.00	603	553	553,000	
500		604	584	292,000	
300		786	765	229,500	
200		419	414	82,800	
100		505	500	50,000	
		2,917	2,816	1,207,300	
1,000	18 Oct. 10.00	603	563	563,000	
500		604	587	293,500	
300		786	763	228,900	

	Price	Date	Tickets		Total (Yen)	
			issued	sold		
Hockey (Komazawa 2nd Hockey Ground)	200		50	45	9,000	
	100		874	869	86,900	
			2,917	2,827	1,181,300	
	1,000	19 Oct. 10.00	603	563	563,000	
	500		604	586	293,000	
	300		786	766	229,800	
	200		445	440	88,000	
	100		479	474	47,400	
			2,917	2,829	1,221,200	
	1,000	21 Oct. 10.00	603	580	580,000	
	500		604	603	301,500	
	300		786	773	231,900	
	200		660	655	131,000	
	100		264	259	25,900	
			2,917	2,870	1,270,300	
			29,170	27,587	11,646,600	
	Hockey (Komazawa 3rd Hockey Ground)	1,000	11 Oct. 10.00	270	238	238,000
		500		540	460	230,000
		300		406	334	100,200
		200		68	63	12,600
		100		632	628	62,800
			1,916	1,723	643,600	
1,000		12 Oct. 10.00	270	228	228,000	
500			540	470	235,000	
300			406	342	102,600	
200			5	0	0	
100			695	691	69,100	
			1,916	1,731	634,700	
1,000		13 Oct. 10.00	270	239	239,000	
500			540	473	236,500	
300			406	353	105,900	
200			217	212	42,400	
100			483	479	47,900	
			1,916	1,756	671,700	
1,000		14 Oct. 10.00	270	211	211,000	
500			540	447	223,500	
300			406	333	99,900	
200	284		279	55,800		
100	416		412	41,200		
		1,916	1,682	631,400		
1,000	15 Oct. 10.00	270	233	233,000		
500		540	508	254,000		
300		406	377	113,100		
200		334	329	65,800		
100		366	362	36,200		
		1,916	1,809	702,100		

	Price	Date	Tickets		Total (Yen)
			issued	sold	
Hockey (Komazawa 3rd Hockey Ground)	1,000	16 Oct. 10.00	270	245	245,000
	500		540	507	253,500
	300		406	377	113,100
	200		303	298	59,600
	100		397	393	39,300
			1,916	1,820	710,500
	1,000	17 Oct. 10.00	270	248	248,000
	500		540	511	255,500
	300		406	385	115,500
	200		77	72	14,400
	100		623	619	61,900
			1,916	1,835	695,300
	1,000	18 Oct. 10.00	270	258	258,000
	500		540	519	259,500
	300		406	389	116,700
	200		524	519	103,800
	100		176	172	17,200
			1,916	1,857	755,200
	1,000	19 Oct. 10.00	270	255	255,000
	500		540	512	256,000
300	406		383	114,900	
200	384		379	75,800	
100	316		312	31,200	
		1,916	1,841	732,900	
		17,244	16,054	6,177,400	
		65,929	61,675	25,360,100	
Judo	3,000	20 Oct. 13.00	2,784	2,776	8,328,000
	2,000		3,615	3,575	7,150,000
	1,000		2,455	2,451	2,451,000
	500		1,235	1,234	617,000
	200		536	336	67,200
	100	1,604	1,476	147,600	
			12,229	11,848	18,760,800
	3,000	21 Oct. 13.00	2,784	2,778	8,334,000
	2,000		3,615	3,601	7,202,000
	1,000		2,456	2,448	2,448,000
	500		1,235	1,235	617,500
	200		1,193	1,043	208,600
	100	947	842	84,200	
			12,230	11,947	18,894,300
	3,000	22 Oct. 13.00	2,784	2,784	8,352,000
	2,000		3,618	3,616	7,232,000
	1,000		2,456	2,454	2,454,000
	500		1,235	1,233	616,500
	200		1,171	1,100	220,000
	100	969	969	96,900	
		12,233	12,156	18,971,400	

	Price	Date	Tickets		Total (Yen)
			issued	sold	
Judo	3,000	23 Oct. 13.00	2,784	2,783	8,349,000
	2,000		3,615	3,612	7,224,000
	1,000		2,456	2,450	2,450,000
	500		1,235	1,235	617,500
	200		1,751	1,710	342,000
100	389	242	24,200		
		12,230	12,032	19,006,700	
		48,922	47,983	75,633,200	
Wrestling	1,000	11 Oct. 11.00	500	474	474,000
	500		1,094	1,072	536,000
	300		600	594	178,200
	200		518	518	103,600
	100		177	152	15,200
			2,889	2,810	1,307,000
	2,000	18.00	500	462	924,000
	1,000		350	332	332,000
	500		734	726	363,000
	300		600	600	180,000
	200		581	568	113,600
	100	114	102	10,200	
			2,879	2,790	1,922,800
	1,000	12 Oct. 11.00	500	461	461,000
	500		1,094	1,078	539,000
	300		600	594	178,200
	200		186	186	37,200
	100		509	484	48,400
			2,889	2,803	1,263,800
	2,000	18.00	500	462	924,000
1,000	350		339	339,000	
500	734		730	365,000	
300	600		595	178,500	
200	683		670	134,000	
100	12	0	0		
		2,879	2,796	1,940,500	
1,000	13 Oct. 11.00	500	468	468,000	
500		1,094	1,073	536,500	
300		600	597	179,100	
200		359	359	71,800	
100		336	311	31,100	
		2,889	2,808	1,286,500	
2,000	18.00	500	472	944,000	
1,000		350	335	335,000	
500		734	731	365,500	
300		600	596	178,800	
200		683	670	134,000	
100	12	0	0		
		2,879	2,804	1,957,300	

Sports	Price	Starting time	Tickets		Total amount (Yen)	
			No. issued	No. sold		
Wrestling	1,000	14 Oct. 11.00	500	474	474,000	
	500		1,094	1,079	539,500	
	300		600	595	178,500	
	200		95	95	19,000	
	100		600	575	57,500	
			2,889	2,818	1,268,500	
	3,000		18.00	500	484	1,452,000
	2,000			350	336	672,000
	1,000			734	734	734,000
	500			601	600	300,000
	200	624		611	122,200	
	100	71		59	5,900	
		2,880		2,824	3,286,100	
	1,000	16 Oct. 11.00		500	466	466,000
	500			1,094	1,075	537,500
	300			600	598	179,400
	200		161	161	32,200	
	100		534	509	50,900	
			2,889	2,809	1,266,000	
	2,000		18.00	500	471	942,000
	1,000			350	345	345,000
	500			734	734	367,000
	300			600	598	179,400
	200	683		670	134,000	
	100	12		0	0	
		2,879		2,818	1,967,400	
	1,000	17 Oct. 11.00		500	484	484,000
	500			1,094	1,085	542,500
	300			599	597	179,100
	200		396	396	79,200	
	100		299	274	27,400	
			2,888	2,836	1,312,200	
	2,000		18.00	500	490	980,000
	1,000			350	345	345,000
	500			734	734	367,000
	300			600	600	180,000
	200	644		631	126,200	
	100	51		39	3,900	
		2,879		2,839	2,002,100	
	1,000	18 Oct. 11.00		500	495	495,000
500	1,094			1,094	547,000	
300	600			599	179,700	
200	353		353	70,600		
100	342		299	29,900		
	2,889		2,840	1,322,200		
2,000	18.00		500	489	978,000	
1,000			350	340	340,000	

Sports	Price	Starting time	Tickets		Total amount (Yen)	
			No. issued	No. sold		
Wrestling	500		734	732	366,000	
	300		600	599	179,700	
	200		683	670	134,000	
	100		12	0	0	
			2,879	2,830	1,997,700	
	1,000		19 Oct. 10.00	500	488	488,000
	500			1,094	1,092	546,000
	300			600	599	179,700
	200			204	204	40,800
	100			491	466	46,600
		2,889		2,849	1,301,100	
	3,000	18.00		500	494	1,482,000
	2,000			350	348	696,000
	1,000			734	734	734,000
	500			600	600	300,000
	200		683	670	134,000	
	100		12	0	0	
			2,879	2,846	3,346,000	
			46,144	45,120	28,747,200	
	Swimming & Diving		2,000	11 Oct. 9.30	2,809	2,779
1,000			3,305		3,298	3,298,000
500		958	955		477,500	
300		869	859		257,700	
200		820	776		155,200	
100		981	966		96,600	
		9,742	9,633		9,843,000	
3,000		16.30	2,808		2,790	8,370,000
2,000			3,305		3,291	6,582,000
1,000			1,867		1,855	1,855,000
500			869	866	433,000	
200			797	780	156,000	
100			61	61	6,100	
			9,707	9,643	17,402,100	
2,000			12 Oct. 10.00	2,808	2,790	5,580,000
1,000				3,305	3,300	3,300,000
500				958	950	475,000
300		869		855	256,500	
200		106		80	16,000	
100		1,695		1,651	165,100	
	9,741	9,626		9,792,600		
3,000	17.30	2,809		2,794	8,382,000	
2,000		3,305		3,303	6,606,000	
1,000		1,867		1,863	1,863,000	
500		869	867	433,500		
200		841	841	168,200		
100		17	0	0		
		9,708	9,668	17,452,700		

Sports	Price	Starting time	Tickets		Total amount (Yen)
			No. issued	No. sold	
Swimming & Diving	2,000	3 Oct. 9.30	2,809	2,786	5,572,000
	1,000		3,305	3,297	3,297,000
	500		958	950	475,000
	300		869	865	259,500
	200		462	418	83,600
	100		1,339	1,295	129,500
			9,742	9,611	9,816,600
	3,000	16.00	2,809	2,798	8,394,000
	2,000		3,305	3,299	6,598,000
	1,000		1,867	1,863	1,863,000
	500		869	865	432,500
	200		703	686	137,200
	100		155	138	13,800
			9,708	9,649	17,438,500
	2,000	14 Oct. 10.00	2,809	2,766	5,532,000
	1,000		3,305	3,289	3,289,000
	500		958	944	472,000
	300		869	859	257,700
	200		272	228	45,600
	100		1,529	1,485	148,500
			9,742	9,571	9,744,800
	3,000	18.30	2,809	2,808	8,424,000
	2,000		3,306	3,306	6,612,000
	1,000		1,867	1,867	1,867,000
	500		869	869	434,500
	200		841	824	164,800
	100		17	0	0
			9,709	9,674	17,502,300
	2,000	15 Oct. 9.30	2,809	2,800	5,600,000
	1,000		3,305	3,293	3,293,000
	500		958	944	472,000
	300		869	850	255,000
	200		431	387	77,400
	100		1,370	1,343	134,300
			9,742	9,617	9,831,700
	3,000	17.00	2,809	2,806	8,418,000
	2,000		3,305	3,304	6,608,000
	1,000		1,867	1,865	1,865,000
	500		869	869	434,500
	200		841	824	164,800
	100		17	17	1,700
			9,708	9,685	17,492,000
	2,000	16 Oct. 10.00	2,809	2,793	5,586,000
	1,000		3,295	3,287	3,287,000
	500		958	946	473,000
	300		869	869	260,700
	200		748	722	144,400
	100		1,053	1,009	100,900

Sports	Price	Starting time	Tickets		Total amount (Yen)	
			No. issued	No. sold		
Swimming & Diving			9,732	9,626	9,852,000	
	3,000	17.30	2,809	2,808	8,424,000	
	2,000		3,305	3,305	6,610,000	
	1,000		1,867	1,866	1,866,000	
	500		869	869	434,500	
	200		801	801	160,200	
	100		57	40	4,000	
			9,708	9,689	17,498,700	
	2,000	17 Oct. 9.30	2,809	2,808	5,616,000	
	1,000		3,305	3,300	3,300,000	
	500		958	953	476,500	
	300		869	865	259,500	
	200		742	698	139,600	
	100		1,059	1,027	102,700	
			9,742	9,651	9,894,300	
	3,000	16.00	2,808	2,808	8,424,000	
	2,000		3,309	3,309	6,618,000	
	1,000		1,867	1,867	1,867,000	
	500		869	869	434,500	
	200		841	824	164,800	
	100		17	0	0	
			9,711	9,677	17,508,300	
	2,000	18 Oct. 10.00	2,809	2,804	5,608,000	
	1,000		3,305	3,304	3,304,000	
	500		960	960	480,000	
	300		869	869	260,700	
	200		937	893	178,600	
	100		864	832	83,200	
			9,744	9,662	9,914,500	
	3,000	16.00	2,809	2,807	8,421,000	
	2,000		3,305	3,304	6,608,000	
	1,000		1,867	1,864	1,864,000	
	500		869	869	434,500	
	200		801	784	156,800	
	100		57	40	4,000	
			9,708	9,668	17,488,300	
		155,594	154,350	218,472,400		
	Modern Pentathlon Shooting, Fencing, Equestrian	1,000	11 Oct. 9.00	290	257	257,000
		300		990	896	268,800
				1,280	1,153	525,800
		1,000	12 Oct. 8.00	504	409	409,000
		300		1,087	1,007	302,100
				1,591	1,416	711,100
	1,000	13 Oct. 9.00	209	209	209,000	
	300		310	309	92,700	
			519	518	301,700	

Sports	Price	Starting time	Tickets		Total amount (Yen)
			No. issued	No. sold	
Athletics, Swimming	1,000 300	14 Oct. 14.30	(Same admission ticket can be used as for other swimming events)		
		15 Oct. 14.00	494	435	435,000
			990	916	274,800
			1,484	1,351	709,800
		4,874	4,438	2,248,400	
Equestrian Sports (Kariuzawa Equestrian Events Ground)	1,000 300	16 Oct. 9.30	708	703	703,000
			432	385	115,500
		17 Oct.	1,140	1,088	818,500
	1,000 300	19 Oct. 13.00	708	697	697,000
			432	426	127,800
			1,140	1,123	824,800
		2,280	2,211	1,643,300	
Equestrian Sports (Equestrian Park)	2,000 1,000 300 200	22 Oct. 10.00	348	348	696,000
			470	467	467,000
			768	768	230,400
			520	516	103,200
			2,106	2,099	1,496,600
	2,000 1,000 300 200	23 Oct. 10.00	348	340	680,000
			470	470	470,000
			768	768	230,400
			520	516	103,200
			2,106	2,094	1,483,600
		4,212	4,193	2,980,200	
Equestrian Sports (National Stadium)	2,000 1,000 500 300 200 100	24 Oct. 8.00	2,508	2,490	4,980,000
			6,940	6,897	6,897,000
			8,898	8,887	4,443,500
			10,032	10,029	3,008,700
			4,804	4,279	855,800
			8,696	8,696	869,600
			41,878	41,278	21,054,600
48,370	47,682	25,678,100			
Fencing (Asaka Shooting Range)	100 100 100 100 100	15 Oct. 9.00	1,190	1,164	116,400
		16 Oct. 9.00	1,190	1,142	114,200
		18 Oct. 9.00	1,190	1,182	118,200
		19 Oct. 9.00	1,224	1,184	118,400
		20 Oct. 9.00	1,237	1,223	122,300
		6,031	5,895	589,500	
Shooting (Tokorozawa Clay Shooting Range)	1,000 300	15 Oct. 9.30	410	392	392,000
			1,060	995	298,500
			1,470	1,387	690,500
	1,000 300	16 Oct. 9.30	410	392	392,000
			1,060	987	296,100
		1,470	1,379	688,100	

Sports	Price	Starting time	Tickets		Total amount (Yen)		
			No. issued	No. sold			
Shooting (Tokorozawa Clay Shooting Range)	1,000 300	17 Oct. 9.30	410	389	389,000		
			1,066	1,037	311,100		
			1,470	1,426	700,100		
			4,410	4,192	2,078,700		
			10,441	10,087	2,668,200		
Volley-Ball (Komazawa Volley-Ball Court)	2,000 1,000 500 300 200 100	11 Oct. 11.00	274	261	522,000		
			613	604	604,000		
			759	737	368,500		
			668	606	181,800		
			150	120	24,000		
			489	459	45,900		
			2,953	2,787	1,746,200		
			2,000 1,000 500 300 200 100	13 Oct. 11.00	274	230	460,000
					613	585	585,000
					759	715	357,500
	669	573			171,900		
	265	235			47,000		
	374	344			34,400		
	2,954	2,682	1,655,800				
	2,000 1,000 500 300 200 100	17 Oct. 17.00	274	236	472,000		
			613	542	542,000		
			759	721	360,500		
			669	577	173,100		
			595	565	113,000		
			44	14	1,400		
			2,954	2,655	1,662,000		
			2,000 1,000 500 300 200 100	14 Oct. 11.00	274	206	412,000
					613	527	527,000
					759	704	352,000
	669	567			170,100		
	80	50			10,000		
559	529	52,900					
2,954	2,583	1,524,000					
2,000 1,000 500 300 200 100	17 Oct. 17.00	274			224	448,000	
		612			553	553,000	
		759			729	364,500	
		669	572	171,600			
		444	414	82,800			
		195	165	16,500			
2,953	2,657	1,636,400					
2,000 1,000 500 300 200 100	15 Oct. 11.00	274	223	446,000			
		613	572	572,000			
		759	735	367,500			
		669	607	182,100			
		155	125	25,000			
		484	454	45,400			

Sports	Price	Starting time	Tickets		Total amount (Yen)
			No. issued	No. sold	
Volley-Ball (Komazawa Volley-Ball Court)	2,000 1,000 500 300 200 100	17.00	2,954	2,716	1,638,000
			274	230	460,000
			613	570	570,000
			759	736	368,000
			667	619	185,700
			609	579	115,800
			30	0	0
	2,952	2,734	1,699,500		
	2,000 1,000 500 300 200 100	17 Oct. 11.00	274	243	486,000
			613	575	575,000
			759	735	367,500
			664	622	186,600
			105	75	15,000
			534	504	50,400
			2,949	2,754	1,680,500
	2,000 1,000 500 300 200 100	17.00	274	258	516,000
			613	601	601,000
			759	744	372,000
			674	637	191,100
			259	229	45,800
			380	350	35,000
			2,959	2,819	1,760,900
	2,000 1,000 500 300 200 100	18 Oct. 11.00	304	304	608,000
			613	613	613,000
			759	759	379,500
			676	676	202,800
			413	383	76,600
			226	196	19,600
			2,991	2,931	1,899,500
	2,000 1,000 500 300 200 100	17.00	289	289	578,000
			613	613	613,000
			759	759	379,500
			674	671	201,300
			483	453	90,600
			156	126	12,600
			2,974	2,911	1,875,000
	2,000 1,000 500 300 200 100	19 Oct. 11.00	274	254	508,000
			613	590	590,000
			759	734	367,000
			675	661	198,300
			107	77	15,400
			532	502	50,200
2,960			2,818	1,728,900	
2,000 1,000 500 300	17.00	293	293	586,000	
		613	613	613,000	
		759	759	379,500	
		674	674	202,200	

Sports	Price	Starting time	Tickets		Total amount (Yen)
			No. issued	No. sold	
Volley-Ball (Komazawa Volley-Ball Court)	200 100		504	474	94,800
			135	105	10,500
			2,978	2,918	1,886,000
	2,000 1,000 500 300 200 100	21 Oct. 11.00	301	301	602,000
			613	613	613,000
			759	758	379,000
			679	674	202,200
			370	340	68,000
			269	239	23,900
			2,991	2,925	1,888,100
	2,000 1,000 500 300 200 100	17.00	303	303	606,000
			613	611	611,000
			759	759	379,500
			679	679	203,700
			609	579	115,800
			30	0	0
			2,993	2,931	1,916,000
	2,000 1,000 500 300 200 100	22 Oct. 11.00	301	301	602,000
			613	613	613,000
			759	759	379,500
			681	681	204,300
			55	25	5,000
			584	554	55,400
			2,993	2,933	1,859,200
	2,000 1,000 500 300 200 100	17.00	303	303	606,000
			613	613	613,000
			759	759	379,500
			679	679	203,700
			171	141	28,200
			468	438	43,800
			2,993	2,933	1,874,200
	2,000 1,000 500 300 200 100	23 Oct. 11.00	301	301	602,000
			613	613	613,000
			759	759	379,500
			679	679	203,700
			30	0	0
			609	579	57,900
			2,991	2,931	1,856,100
	2,000 1,000 500 300 200 100	17.00	297	297	594,000
			619	619	619,000
			763	763	381,500
			683	683	204,900
609			579	115,800	
30			0	0	
3,001			2,941	1,915,200	
		56,447	53,559	33,701,500	

Sports	Price	Starting time	Tickets		Total amount (Yen)
			No. issued	No. sold	
Volley-Ball (Yokohama Cultural Gymnasium)	2,000	12 Oct. 15.00	352	306	612,000
	1,000		804	760	760,000
	500		662	637	318,500
	300		576	558	167,400
	200		136	108	21,600
	100		525	498	49,800
			3,055	2,867	1,929,300
	2,000	13 Oct. 17.00	352	307	614,000
	1,000		804	772	772,000
	500		662	632	316,000
	300		576	542	162,600
	200		364	336	67,200
	100		297	270	27,000
			3,055	2,859	1,958,800
	2,000	14 Oct. 17.00	352	305	610,000
	1,000		804	764	764,000
	500		662	634	317,000
	300		576	565	169,500
	200		470	445	89,000
	100		201	201	20,100
			3,065	2,914	1,969,600
	2,000	15 Oct. 17.00	352	299	598,000
	1,000		804	767	767,000
	500		662	649	324,500
	300		576	548	164,400
	200		117	92	18,400
	100		554	554	55,400
			3,065	2,909	1,927,700
	2,000	17 Oct. 13.00	352	298	596,000
	1,000		804	795	795,000
	500		662	642	321,000
	300		576	565	169,500
	200		490	465	93,000
	100		181	181	18,100
			3,065	2,946	1,992,600
	2,000	18 Oct. 13.00	378	378	756,000
	1,000		834	834	834,000
	500		662	662	331,000
	300		576	576	172,800
	200		556	556	111,200
	100		114	90	9,000
			3,120	3,096	2,214,000
	2,000	19 Oct. 17.00	352	345	690,000
	1,000		829	829	829,000
	500		662	656	328,000
	300		576	573	171,900
	200				
	100		372	344	68,800

Sports	Price	Starting time	Tickets		Total amount (Yen)	
			No. issued	No. sold		
Volley-Ball (Yokohama Cultural Gymnasium)	100		289	262	26,200	
			3,080	3,009	2,113,900	
	2,000	21 Oct. 17.00	386	386	772,000	
	1,000		834	834	834,000	
	500		662	662	331,000	
	300		576	576	172,800	
	200		475	447	89,400	
	100		186	159	15,900	
			3,119	3,064	2,215,100	
	2,000	22 Oct. 17.00	388	388	776,000	
	1,000		834	834	834,000	
	500		662	662	331,000	
	300		576	576	172,800	
	200		598	570	114,000	
	100		63	48	4,800	
			3,121	3,078	2,232,600	
	2,000	23 Oct. 11.00	392	392	784,000	
	1,000		834	834	834,000	
	500		662	662	331,000	
	300		576	576	172,800	
	200		504	504	100,800	
	100		166	154	15,400	
			3,134	3,122	2,238,000	
			30,879	29,864	20,791,600	
			87,326	83,423	54,493,100	
	Water-Polo	1,000	11 Oct. 10.00	440	408	408,000
		500		485	443	221,500
		300		657	568	170,400
		200		184	161	32,200
		100		632	627	62,700
				2,398	2,207	894,800
		1,000	16.30	440	410	410,000
		500		485	437	218,500
		300		657	578	173,400
		200		722	666	133,200
		100		94	39	3,900
				2,398	2,130	939,000
		1,000	12 Oct. 10.00	440	370	370,000
		500		485	454	227,000
		300		657	580	174,000
		200		192	176	35,200
		100		624	624	62,400
				2,398	2,204	868,600
		1,000	16.30	440	397	397,000
		500		485	418	209,000
		300		657	561	168,300

Sports	Price	Starting time	Tickets		Total amount (Yen)
			No. issued	No. sold	
Water-Polo	200		665	609	121,800
	100		151	96	9,600
			2,398	2,081	905,700
	1,000	13 Oct. 10.00	440	382	382,000
	500		485	436	218,000
	300		657	575	172,500
	200		78	62	12,400
	100		738	738	73,800
			2,398	2,193	858,700
	1,000	16.30	440	414	414,000
	500		485	441	220,500
	300		657	555	166,500
	200		761	705	141,000
	100		55	0	0
			2,398	2,115	942,000
	1,000	14 Oct. 13.00	440	417	417,000
	500		485	431	215,500
	300		657	574	172,200
	200		694	688	137,600
	100	122	117	11,700	
		2,398	2,227	954,000	
	1,000	15 Oct. 13.00	440	423	423,000
	500		485	464	232,000
	300		657	569	170,700
	200		674	618	123,600
	100	142	137	13,700	
		2,398	2,211	963,000	
	1,000	17 Oct. 13.00	440	434	434,000
	500		485	484	242,000
	300		657	622	186,600
200	704		648	129,600	
100	112		107	10,700	
	2,398	2,295	1,002,900		
1,000	18 Oct. 13.00	440	434	434,000	
500		487	487	243,500	
300		657	629	188,700	
200		711	655	131,000	
100		105	100	10,000	
	2,400	2,305	1,007,200		
	23,982	21,968	9,335,900		
Yachting	1,000	12 Oct. 11.00	390	358	358,000
	1,000	13 Oct. 11.00	390	337	337,000
	1,000	14 Oct. 11.00	390	288	288,000

Sports	Price	Starting time	Tickets		Total amount (Yen)
			No. issued	No. sold	
Yachting	1,000	15 Oct. 11.00	390	366	366,000
	1,000	19 Oct. 11.00	401	401	401,000
	1,000	20 Oct. 11.00	394	394	394,000
	1,000	21 Oct. 11.00	437	437	437,000
			2,792	2,581	2,581,000
Closing Ceremony	8,000	24 Oct. 13.00	4,641	4,641	37,128,000
	5,000		5,999	5,996	29,980,000
	3,000		13,106	13,106	39,318,000
	2,000		16,964	16,962	33,924,000
	1,000		13,889	13,887	13,887,000
	500		5,267	5,264	2,632,000
	200		944	944	188,800
	100		502	502	50,200
			61,312	61,302	157,108,000
Demonstration Base-ball	1,000	11 Oct. 10.00	2,377	2,176	2,176,000
	500		4,906	3,270	1,635,000
	300		11,605	5,226	1,567,800
	200		8,260	3,060	612,000
	100		21,847	21,543	2,154,300
			48,995	35,275	8,145,100
Demonstration Budo	1,000	15 Oct. 10.00	4,654	4,436	4,436,000
	300		4,192	3,839	1,151,700
	100		1,468	666	66,600
			10,314	8,941	5,654,300
		59,309	44,216	13,799,400	
	Total		2,143,635	2,061,183	1,910,480,100

Tickets and amounts involved in Six scheduled Games events cancelled

Venues	Date	No. of Tickets	Total Amount (Yen)
National Stadium	12	62,851	22,147,500
Prince Chichibu Football Field	15	15,520	6,829,900
Komazawa Stadium	11	18,816	7,594,600
Mitsuzawa Football Field	16	11,471	3,864,600
Omiya Football Field	13 14	23,774	7,481,600
Total		132,432	47,918,200

Number of Admissions to each sports venue

Sports venue	Capacity	10th	11th	12th	13th	14th	15th	16th	17th	18th	19th	20th	21st	22nd	23rd	24th	Total
National Stadium	74,160	74,534	58,724			10,285 54,306	9,537 55,053	5,879 62,778	10,047 63,007	9,718 51,147	9,004 56,490	9,383 60,694	64,856		60,565	36,510 79,383	841,900
Tokyo Metropolitan Gymnasium	6,474									5,564 5,254	6,132 5,557	5,594 6,084	5,477 5,835	6,119	5,987		57,603
Meiji Jingu Baseball Field Stadium	50,680		29,917														29,917
Tokyo Metropolitan Indoor Swimming Pool	3,014		2,160 2,326	2,213 2,126	2,201 2,113	2,089	2,238		2,149	1,984							21,599
Prince Chichibu Memo- rial Football Field	17,569				16,372	14,679		13,510		12,758		14,985					72,304
National Gymnasium	11,317		10,383 11,559	9,363 10,177	9,105 10,045	9,355 10,534	9,309 12,149	9,263 11,680	9,328 9,842	9,464 11,031							162,587
National Gymnasium Annex	3,929		3,650 3,500	2,986 3,174	3,030 3,500	3,259 3,079		3,191 3,861	2,840 3,550	3,283 3,406		3,419 3,274	3,746 4,023	3,534 3,465	3,629 4,100		75,499
Shibuya Public Hall	2,222		1,933 2,150	1,792 2,074	1,737 1,602	1,557 1,693		1,421 1,586	1,353 1,459	1,532 1,918							23,807
Komazawa Stadium	20,784			15,312	18,311	17,613	18,178	18,474		16,001		17,762					121,651
Komazawa Volley-Ball Court	3,908		2,970		2,974 2,514	2,895 2,948	3,671 3,492		3,491 3,454	3,417 3,082	3,332 3,141		3,465 3,061	3,148 3,144	2,932 4,056		61,187
Komazawa Gymnasium	3,875		4,466 3,233	3,475 3,461	3,752 3,522	3,667 4,210		3,948 3,586	4,297 3,877	4,031 3,578	4,198 4,520						61,821
Komazawa 1st Hockey Ground	2,056		1,674	1,425	1,468	1,261	1,515	1,951	1,613	1,327	2,173		2,065	2,096	2,536		21,104
Komazawa 2nd Hockey Ground	3,432		2,999	2,742	2,677	2,388	3,422	2,659	2,986	2,617	3,408		2,991				28,889
Komazawa 3rd Hockey Ground	2,343		2,172	2,036	1,671	1,486	2,174	1,859	1,958	1,815	1,893						17,064
Hachioji Cycling Road Race Course	2,980					1,175								1,901			3,076
Hachioji Velodrome	4,122							3,444	2,966		2,866		2,288				11,564
Equestrian Park	2,617													2,761	1,925		4,686
Nippon Budokan Hall	14,148						8,179					11,413	11,206	10,879	11,541		53,218
Waseda Memorial Hall	2,194			1,042	1,300	1,298	1,360	1,411	1,441	1,320	1,412	1,358	1,368	1,269	1,347		15,926
Korakuen Ice Palace	4,467		3,641 3,116	3,190 2,958	3,160 2,747	2,897 3,080	3,052 3,217	3,428 3,562	3,519 3,182	3,349 3,131	3,218 3,504	3,591 3,461	3,246 3,598		4,388		76,235
Yokohama Cultural Gymnasium	3,784			4,805	3,905	3,864	3,737		3,991	3,802	3,908		3,689	3,747	4,305		39,753
Mitsuzawa Football Field	10,102		12,664	11,986	12,529	10,358	12,194			9,643							69,374
Lake Sagami	1,500											911	946	969			2,826
Sagami Bay	406			365	276	327	397				349	420	446				2,580
Tokyo University Kemi- gawa Play Ground	1,504						3,934										3,934
Karuizawa Equestrian Ground	1,524							546	331		703						1,580
Toda Bowling Course	8,262		6,556	6,910	6,513	552	6,396										26,927
Asaka Shooting Range	1,200				340		584	580		578	571	583					3,236
Tokorozawa Clay Shooting Range	1,284						1,538	1,464	1,524								4,526
Omiya Football Field	14,392		11,974	12,310			12,264	12,391		9,604							58,543
Asaka Nezu Park	1,300		807														807
Total	281,234	74,534	182,574	105,922	117,364	170,855	177,590	172,472	142,205	184,354	116,379	142,932	122,306	43,032	107,311	115,893	1,975,723

Note : Double figures indicate shift system numbers.

Overseas Official Ticket Agencies

Country	Name of Agency	Country	Name of Agency
Afghanistan	National Olympic Federation of Afghanistan, Kabul	Finland	Suomen Matkatoimistoyhdistys r. y. Travel Bureau Association of Finland, Pohj. Espanaadikatu 2, Helsinki
Argentina	Automovil Club Argentino, Avenida Libertador, General San Martin 1850, Buenos Aires	France	L'Agence des Wagons-Lits, 14 Boulevard des Capucines, Paris-9
Australia	Thomas Cook & Son, Pty. Ltd., 159-161 Collins Street, Melbourne, C. 1 The Commercial Bank of Australia Ltd., 337 Collins Street, Melbourne, C. 1	Germany (East)	Deutsches Reisbüro der Deutschen Demokratischen Republik, Friedrichstrasse 110-112, Zentrale Leitung, Berlin N. 4
Austria	Österreichisches Verkehrsbüro, Gesellschaft M. B. H. Friedrichstrasse 7, (Wien 1)	Germany (West)	Deutsches Reisebüro GMBH, Eschersheimer Landstr, 25-27 (Postshliessfach 3621) Frankfurt/Main
Barbados	H. B. Niblock & Co., Broad Street, Bridgetown, Barbados	Great Britain	The Association of British Travel Agents, 10 Mayfair Place, London, W. 1
Belgium	Comité Olympique Belge, 14 Rue Guimard, Bruxelles 4	Greece	Hermes en Greece, Stadiou 4, Athènes
Bermuda	Wm. E. Meyer & Co., Ltd., Ried Street, Hamilton	Hong Kong	Great Eastern Tourist Enterprise, 402 Hing Wai Bldg., 36 Queen's Road Central, Hong Kong
Bolivia	Agencia de Turismo "Exprinter", Casilla No. 2345, La Paz	Hungary	IBUSZ/Hungarian Travel Agency, Felszabadulás tér 5, Budapest V.
Brazil	Banco America do Sul S. A., Rua Senador Feijó, 197/205, São Paulo The American Express S. A., Rua Mexico 74-B, Rio de Janeiro	India	Mercury Travels (India) Private Ltd., Oberoi Grand Hotel, Calcutta 13
Bulgaria	"BALKANTOURISTE", Lenine Palace 16, Sofia	Iran	IRTUC Travel Agency, 71 Ferdowsi Avenue, Teheran
Canada	O. K. Johnson & Co., Ltd., Travel Agents 697 Bay Street, Toronto 2, Canada	Iraq	Universal Travel Bureau, Rashid Street, Sinik, Baghdad (P. O. Box No. 265, Baghdad)
Cambodia	"Société Commerciale Khmère" AIR VOYAGES, No. 61 Preah Bat Norodom, Phnom-Penh	Ireland	The Irish Travel Agency Ltd., 8 D'Olier Street, Dublin
Ceylon	Ceylon Carriers Ltd., 20-A York Street, Colombo 1	Israel	"Peltours" Ltd., 28 Ahad Haam Str. (P. O. Box 394) Tel-Aviv
Chile	Litvak, Bandera 191, Santiago	Italy	Compagnia Italiana Turismo (C. I. T.), Piazza della Repubblica 68, Rome
Colombia	Agencia de Turismo TASA, Avenida Jiménez No. 4-92, (Apartado Aéreo 14514) Bogota	Jamaica	Martin's Travel Service "The House of Travel", Corner Harbour & East Streets, Kingston, Jamaica B. W. I. (P. O. Box 226, Kingston)
Cuba	Comite Olimpico Cubano, Amisted 419, altos, Havana	Jordan	Jordan Olympic Committee, P. O. Box 413, Amman
Czechoslovakia	La Société CEDOK, Příkopy 18, Prague	Kenya	Express Transport Co., Express House, 41 Victoria Street, Nairobi (P. O. Box 433, Nairobi)
Denmark	Danmarks Rejsebureau Förening, "OLYMPIADE KONTORET" Artillerivej 147, Copenhagen S, Denmark	Korea	Korea Tourist Bureau, Bando Hotel, Seoul Global Travel Service, Ltd., 104 Bando Hotel, Seoul "BLUE STAR"
Indonesia	S. E. L. Maduro & Sons, Inc., De Ruyterplein 2, Curacao	Lebanon	Tourism & Travel Agency, Saudi Bank Bldg., Bab Edriss (P. O. Box 1604) Beyrouth
Ecuador	Metropolitan Touring, Benalcázar No. 669, (P. O. Box 2542) Quito	Libya	Libyan Tourist & Hotel Organization, O, T.A.L, Ikbal Street, 10/16, Tripoli
Ethiopia	Ethiopian Tourist Organization, P. O. Box 2183, Addis-Abéba		
Fiji	Hunts Travel Service, Bank of New Zealand Building, Suva (P. O. Box 55, Suva)		

Country	Name of Agency	Country	Name of Agency
Luxemburg	Bureau de Voyages et d'Emigration, Derulle-Wigreux & Fils, 59 Boulevard Royal, Luxembourg	Sweden	The Association of Swedish Travel Agents (Svenska Resebyråföreningen), Postbox 16036, Stockholm 16
Mali	AIR MALI, Bamako	Switzerland	Fédération Suisse des Agences des Voyages, Swiss Federation of Travel Agencies, 15 Rue de Bourg, Lausanne
Malta	Malta Tours Ltd., 53 St. Lucis Street, Valletta	Syria	Orient Express, P. O. Box No. 2457, Fardoss St., Damas
Malaysia	Harper, Gilfillan Ltd., No. 44 Pudu Road, Kuala Lumpur	Taiwan	Taiwan Travel Service, 1786 Chung Cheng Rord, Taipei
Mexico	Mexico Travel Plans, S. A., Plaza de la República No. 43-B, Mexico 1, D. F.	Tanganyika	J. W. Kearsley (E. A.) Ltd., Windsor Street, (P. O. Box 801) Dar es Salaam
Morocco	T. A. M., 4 Avenue Moulay Youssef, Rabat	Thailand	World Travel Service Ltd., 1035 Charoen Krung Road, Bangkok
Nepal	Royal Nepal Airlines Corporation New Road, Kathmandu	Tunisia	Comité de Navigation Tunisienne, Avenue Habib Bourguiba, Tunis
Netherlands	Reisbureau Lissone-Lindeman N. V., Pletterijkade 50, The Hague	U.A.R	Misr Travel & Shipping, 7 Rue Talaat Harb Boite Postal 1000, Le Caire
New Zealand	The Union Steam Ship Co. of New Zealand Ltd., P. O. Box 1799, Wellington	Uganda	Equatorial Agencies Ltd., P. O. Box 2202, Kampala
Nigeria	The West Africa Travel Agency, 9A Martins Street, Lagos	Uruguay	Asociacion Uruguaya de Agentes de Viajes (AUDAVI), Sarandi 700-Montevideo, Uruguay
North Rhodesia	Turnbull, Gibson & Co. (N. R.) Limited, Travel Agents, P. O. Box 62, Chingola	U.S.A.	American Express Co., 65 Broadway, New York 6, N. Y.
Norway	Metro Reisebureau A/S, Kral Johansgt. 31, Oslo	U.S.S.R.	"INTOURIST", 16 Avenue Marx, Moscow, U.S.S.R.
Pakistan	Highland Travels, The Mall, Lahore	Venezuela	Agencia de Viajes "El Conde", Conde a Padre Sierra, Edificio Hotel El Conde, (Apartado No. 3951) Caracas
Panama	"Balboa Express", P. O. Box 4396, Panama City	Viet Nam	Office National du Tourisme du Viet-Nam 25 Ben Bach-Dang, Saigon
Peru	Wagon Lits Cook, Jr. Unión 801, Lima KINJYO Travel Service, Ave. Abancay No. 346, Lima	Yugoslavia	Jugoslovenski Aerotransport/JAT/Bircaninova 1/111, Beograd, (P. O. Box 749)
Philippines	Far Eastern Travel Agency, Inc., 1123-11 25 A. Mabini, Ermita, Manila		
Poland	Sports-Tourist, ul. Marszalkowska 84/92, Warszawa		
Portugal	Casa Atlantica de Viagens, Ltda., Rua Capelo, 4-A, Lisboa-2		
Rhodesia	Thomas Cook & Sons Ltd., P. O. Box 631, Bulawayo, Southern Rhodesia		
Rumania	Comité Olympique Roumain, 16 Str. Vasile Conta, Bucharest		
San Marino	Mme. Tina Gianello, c/o Centro Turistico Sammarinese Repubblica di San Marino		
Senegal	"HAVAS EXPRINTER", 29 Boulevard, Pinet-Laprade à DAKAR		
South Africa	Weightman's Travel Bureau, (Pty) Ltd., Southern Life Building, Harrison Street, (P. O. Box 859) Johannesburg		
Spain	Viajes Universal, S. A., Rue Alcalá Galiano, Madrid 3		



Many waited all night at this stadium to receive order of priority numbers to entitle them to purchase Olympic admission tickets. These priority numbered tickets, (below at right)



Each single admission ticket was carefully registered and kept under rigid control. (At left) tickets are being registered. (Below) a waiting line of ticket purchasers.



ADMINISTRATION OF THE OLYMPIC GAMES VENUES

Planning and Programming for the Administration of the Olympic Games Sites

In order to achieve efficient administrative functions, from the preparatory arrangements up to their actual execution, much consideration was given to the effective organization and to the educational and training programmes for the personnel involved. The following five factors were regarded as essential targets of this administrative function.

(1) Negotiations to lease 30 main games sites on as desirable and complete terms and conditions as could be obtained.

(2) Complete arrangements of seating for spectators and the efficient and accurate execution of ticket handling and ushering.

(3) Systematic and orderly operation of all facilities in the games sites, to provide the most desirable conditions both for the management of the games themselves and for the spectators.

(4) Reasonable regulations of games sites and developing of a desirable audience reaction.

(5) Adequate administration and inspection of factors of cleaning and sanitation, shopping facilities, mail service and money exchange service in games sites.

The Background of the Administrative Activities

Many of the games sites for Games of the 18th Olympiad, Tokyo were located in central Tokyo where the roads were narrow and traffic was extremely congested. Open space for parking and other purposes was extremely limited.

In addition to the traffic difficulties, the numbers of participating nations and domestic and foreign spectators which would attend were thought to exceed those of the previous Olympic Games in Rome. On 1st April 1962, an office was set up in the Transportation and Communication Division in the name of the Stadium Section. On 10th April 1964, this section was transferred to the Stadium and Ticket Division immediately upon its establishment. Just before the opening of the Games, this section was expanded to include 64 regular staff members and a support group of fire brigade personnel and students, making a total man/day strength of 27,707.

Development in Basic Administration Procedure

The full analysis was made of the past historic records of accidents, death and injury in public gatherings, and of the causes and effects of any confusion or congestion which had arisen on those occasions. This investigation made it clear that in past domestic games, the administration of games sites had usually been arranged on temporary basis, and educational and training programme had seldom been prepared for administrative personnel on duty.

To prevent accidents and to control spectators within the limit of seating capacity, it was decided that a full educational and instructional programme would be necessary, so that all personnel involved in any duties whatsoever would be thoroughly acquainted with their specific duties and responsibilities under any and all circumstances.

Fundamental Policy on the Site Administration

The following points were given as the fundamental policy on organizing the administration system for Olympic games sites.

(1) Allocation of spectators in accordance with seat capacity in each games site.

(2) Necessary arrangement for prevention of accidents in games sites and first-aid service, and medical service.

(3) Various auxiliary services to give safety and pleasure to spectators.

Organization of Administration

Field office and site management A field office of the Olympic Organizing Committee was set up at each games site. A manager was appointed to each office with adequate assistants and field clerks.

For the allocation of seats, on-the-spot surveys were conducted at each site and the numbers of spectators to be admitted were determined after careful consultations with the athletic associations concerned.

In order to allow a maximum number of persons the opportunity to view the events, a shift system was adopted in certain of the events after carefully taking into consideration the kind and time of the events. The careful preparation of procedures

Silhouette Symbols ①

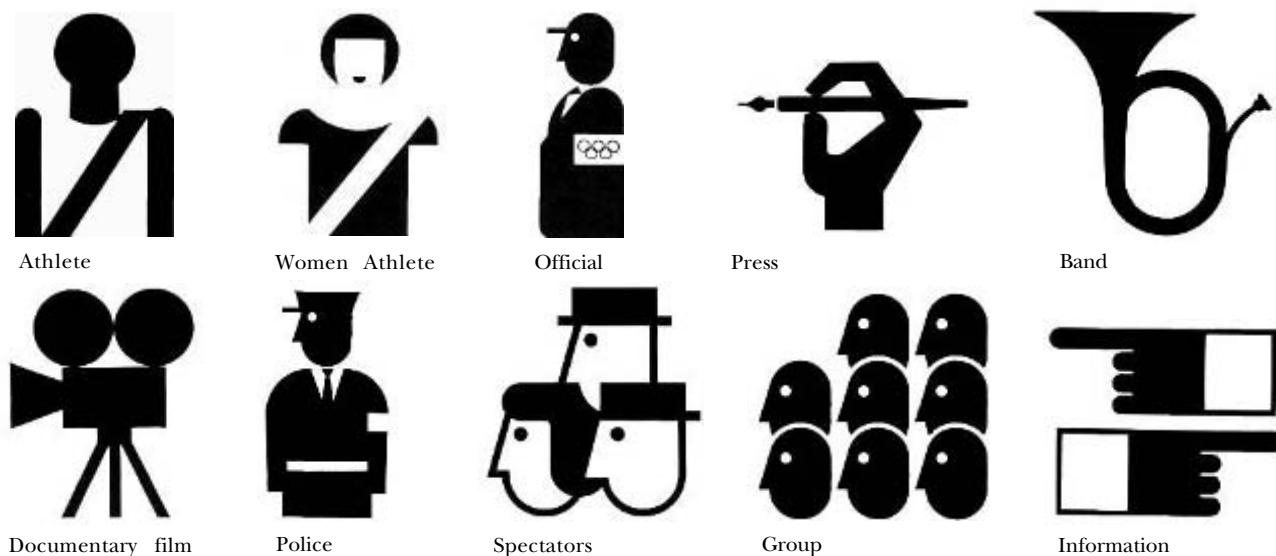

meant that;

- Spectators were able to enter in orderly manner, without confusion;
- Spectators were kept in good order;
- Illegal entrance was prevented.

Cooperation of the fire-fighting organizations

Full cooperation of the fire-fighting organizations was requested in order to carry out efficient administrative functions in all games sites.

Close cooperation was also extended by college students of the athletic clubs in each university, and officials of prefectures, cities, towns, where Olympic games sites were located.

The members of the Olympic Youth Conference were also requested to offer cooperation to act as members of the information offices at the sites within the Metropolis.

Activities by fire-fighting organizations for prevention of accidents

The Fire Board and local fire departments conducted official inspections on games sites and facilities and gave necessary administrative instructions for prevention of accidents. During the Olympic Games, they were on duty to prevent

accidents and casualties with fire-engines and ambulances ready for operation.

First aid and relief services The first-aid services were rendered by the fire-fighting organizations and members of the Self Defence Forces, working in close liaison with medical and sanitary institutes. Careful attention was directed at all times to the spectators, and prudential consideration was given to early discovery and treatment of injured personnel or persons requiring assistance.

Information offices and guide signs Information offices were set up in games sites for the convenience of spectators. Signs were prepared in order to indicate the location of information services and classified seats for spectators.

Sales stands Sales stands were controlled by the medical and sanitary institutions and Fire Departments.

Cleaning Cleaning of the sites was arranged under individual contracts made at the time of leasing the sites.

The Decision on Gate-Opening Time

The timing of the gate-opening before ceremonies and games would materially affect the member of ticket examiners, ushers, other field clerks and guards. Programmes were made through "operations research", and decisions were reached on the basis of data obtained by electronic computer calculations of the optimum time in any given situation.

(1) The gate-opening time for the opening ceremony was fixed at 1000 hours, 3 hours before arrival of the buses of athletes.

(2) The gate-opening time for the games in general was fixed at a time 30 minutes to 2 hours before the games in due consideration of the kinds of games, starting time, seating capacity and other factors involved at the sites.

Silhouette symbols were used like this



Silhouette Symbols ②



First Aid



Men's Toilet



Women's Toilet



Telephone



Bank



Post Office



Cloak Room

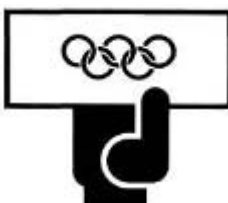

Tickets Sales room

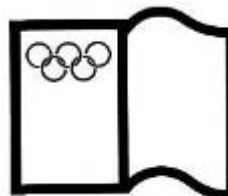

Programme Sales room



Olympic Village

Issuance of Free Passes

Entrance to games sites was limited exclusively to holders of admission tickets and personnel qualified under Article 48 of the Olympic Charter. Free access to the sites was also necessary for officials of government offices concerned and personnel engaging in the management of facilities. For these personnel, passes were issued classified into three categories as shown below:—

- (1) Class No. 1, providing admission to all games sites
- (2) Class No. 2, providing admission to designated site or sites only
- (3) Class No. 3, providing the bearer only the first admission gate at the site designated

Personnel Programme

All personnel detailed to games sites wore uniforms arranged by the Organizing Committee. The personnel assigned for games sites management are as shown in the table in this section.

Work Hours for Ticket Examiners and Field Operators

Hours of work were fixed basically at eight hours a day. Two hours of overtime were however deemed inevitable according to the progress of games. A shift system was applied where 10 or more hours of operation was anticipated, and the personnel programmes were established for each games site on this principle.

Eventually, a two-shift system was adopted in the light of health administration, and also for the purpose of providing smooth operations for a considerable long period, provided that all members were mobilized at peak times or whenever it was deemed necessary. In some cases the actual hours

of work were prolonged beyond the envisaged limits due to changes in programmes or prolonged games. The final event of the Pole Vault which was scheduled to be ended at 17:00, for example required personnel on duty until mid-night.

Communication Facilities

Telephones were installed at headquarters, wickets, information desks, several places on the stand, fire-stations and ambulances or liaison centres of each games site.

The fire-reporting line was used jointly and separate lines were installed to connect sites within the Tokyo Metropolis for exclusive use. The lines were also installed for exclusive use at sites outside the city area where the fire headquarters were stationed.

Operations

Checking admission tickets A double check system was adopted in principle in order to ensure correct checking for admission tickets and smooth entrance of spectators. A half portion of admission ticket was indented in two pieces so that it could

Silhouette symbols were also used like this



Silhouette Symbols ③



Drinking Water

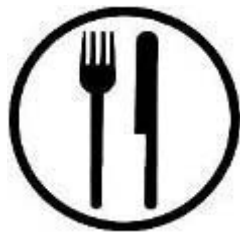

Dining Room



Snack Room



Dressing room

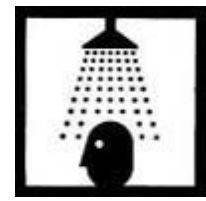

Shower



Interview Room



Meeting Room



Shopping Centre



Theatre



Club

be torn off twice for checking. However, a single checking system was adopted in certain games sites where building structures, or size of the site made this more expedient.

Entrance gates were set up separately each for general spectators, group spectators and personnel related to the games.

The first entrance gate was indicated by alphabetical letters, and second entrance by Arabic digits for the convenience of foreign visitors.

As a general rule, the number of spectators to be handled at each entrance was limited to some 1,000 in the case of the indoor gymnasiums and approximately 1,200 in the case of out-door events.

The first gate for general spectators were posted with five checkers in order to control waiting spectators in line, to check and tear off indented half of tickets, and to usher them to a second gate, etc.

The first gate for group spectators were posted with three checkers to check group certificates and tickets, etc. In these cases, one usher accompanied each group of 200 spectators.

At the entrance gate for the officials concerned to the games, receptionists, ushers and two checker were posted.

Field management Primary requirements were to usher spectators, to maintain order, and to give proper instruction and guidance in case of emergency or accidents. It was essential that this function and service be carried out thoroughly and smoothly to prevent confusion.

To effect this, each site was divided into several control sections. Under a field director of the Organizing Committee, there were a field manager, section heads and group leaders at each site. The field manager and the section heads were also responsible for the tickets admission duties. The following chart shows the organization of the field management:

Reservation system was applied to all seats in the gymnasiums, the National Stadium, the Komazawa Sports Park and Equestrian Park, with partial exception of non-reserved seats at some other sites.

This reservation system was effective to maintain order with the spectators at the entrance and to prevent consequent confusions.

Field clerks were given adequate instructions and training, and each carried charts of seat allocation, and specific seat numbers.

At the second gate, a full-time-service clerk was

Silhouette Symbols ④

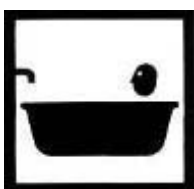

Bathroom



Sauna

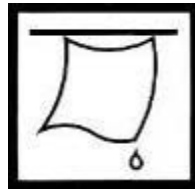

Laundry Room



Bicycles



Buses

posted to check the attendance by use of a counter and reported thereon to the headquarters every half hour.

Attendance was counted at the first gate in certain venues where the second gate was not provided.

Special attention was given to the seats on the arena where no emergency exits were provided and where entrance gates was used both by officers, players and general spectators. Efforts were made at such places to insure smooth progress of programmes.

At the sites where a second gate was not provided, it was noted that many unauthorized persons attempted to go into spectators' stands or arena.

Most of the group spectators were students of primary, junior and senior high schools. They were led by a responsible leader per a group of 20 students and were ushered by an attendant per a group of 200 students.

Information service Information offices were set

up at each games site for the convenience of spectators. There were five such offices at the National Stadium, and one to three each at other sites, or a total of 38 offices. There were however not adequate to provide full satisfaction to spectators, by reason of the huge area covered by the individual sites.

Interpreters were posted at each site to offer linguistic assistance to foreign visitors.

Public telephones were also installed at each venue. The functions of the Information Office were:

- Information on facilities
- Information on programmes
- Disposal of complaints concerning admission tickets
- Liaison tasks in respect to the first aid and relief measures
- Assistance for lost children
- Information on transportation, hotel and tourism services
- Public telephone service

Security and Traffic Division posted personnel to

A scene at Gate B of the Main Stadium as spectators line up for admission



the information office for purposes of lost and found articles and to keep contact with police offices.

Leasing Arrangement for Games Sites

The policy had been established on leasing arrangements that no rentals be paid for public facilities owned by the Government, City of Tokyo, and prefectural government, but rentals would be paid for the privately owned facilities.

The expenses needed in connection with the training of athletes or administration of the games were to be fully borne by the Organizing Committee. Negotiations were made with the competent managers on matters of the period of use, or cost calculation since August 1963 and final agreement had been reached by September 1964.

Prevention of Accidents

Security for the safety of human lives and accident prevention was a priority requirement.

After surveying all the sites, the following measures were taken:—

As a general rule, reservation system was applied to all seats. The number of spectators was limited strictly to the seating capacity.

Preliminary instructions and trainings were given to field clerks so that they could take expeditious measures against accidents and security of human lives.

Guards were placed at each all electric and gas utilities outlets stations to prevent accidents. Especially at night, patrolmen were reinforced for prevention and earlier detection of fire and theft.

An officer was assigned in charge of fire prevention, as provided for by law, to every venue for

Numbers of supervisory personnel attached to each sports venue

Venues	10th	11th	12th	13th	14th	15th	16th	17th	18th	19th	20th	21st	22nd	23rd	24th	
National Stadium	1,413	921			913	913	913	913	913	910	910	910		925	1,391	11,945
Prince Chichibu Memorial Football Field				119	119		119		119		119					595
Tokyo Metropolitan Gymnasium									△204	△204	△204	△204	△204	△204		1,224
Tokyo Metropolitan Indoor Swimming Pool		△100	△100	△100	50	50		50	50							500
National Gymnasium		△310	△310	△310	△310	△310	△310	△310	△310							2,480
National Gymnasium Annex		△150	△150	△150	△150		△150	△150	△150		75	75	75	75		1,350
Shibuya Public Hall		△118	△118	△118	△118		△118	△118	△118							826
Komazawa Stadium			147	147	147	147	147	147	147		147					1,029
Komazawa Gymnasium		△130	△130	△130	△130		△130	△130	130	△130						1,040
Komazawa Volley-Ball Court		92		92	92	92	92	92	92	92		92	92	92		920
Komazawa 1st Hockey Ground		46	46	46	46	46	46	46	46	46		46	46	46		552
Komazawa 2nd Hockey Ground		42	42	42	42	42	42	42	42	42		42				420
Komazawa 3rd Hockey Ground		42	42	42	42	42	42	42	42	42						378
Equestrian Park													52	52		104
Waseda Memorial Hall			△100	△100	△100	△100	△100	△100	△100	△100	△100	△100	△100	△100		1,200
Korakuen Ice Palace		35	35	35	35	35	35	35	35	35	35	35		35		420
Nippon Budokan Hall						197					217	217	217	217		1,065
Hachioji Velodrome							48	48		48		48				192
Hachioji Cycling Road Race Course					120								120			240
Yokohama Cultural Gymnasium			63	63	63	63		63	63	63		63	63	63		630
Mitsuzawa Football Field		110	110	110	110	110			110							660
Sagami Bay			25	25	25	25				25	25	25				175
Lake Sagami											26	26	26			78
Toda Rowing Course		98	98	98	98	98										490
Asaka Shooting Range				28			28	28		28	28	28				168
Asaka Nezu Park		26														26
Tokorozawa Clay Shooting Range						24	24	24								72
Omiya Football Field		118	118			118	118		118							590
Tokyo Univ. Kemigawa Playing Grounds						22										22
Karuizawa Equestrian Events Ground																63
Meiji Jingu Baseball Field Stadium		255					21	21		21						255
Total	1,413	2,593	1,634	1,755	2,710	2,434	2,391	2,212	2,789	1,786	1,886	1,911	995	1,809	1,391	29,709

Note: Figures with △ mark indicate shift system numbers

adequate performance of fire prevention and administration.

Constant checking and inspection were practiced on fire fighting equipment. Fire extinguishers were installed at temporary buildings and structures.

The location and structure of sales stands and other temporary constructions were checked from the viewpoint of fire prevention, especially at places where naked flame or heat was in use.

Establishment of Sales Stands in the Games Sites

Sales stands were established at each games site and restaurants were provided at certain sites where such facilities were accommodated.

Food and beverage dealers were requested to obtain legal licences, on their own responsibility, from the relevant authorities.

The articles approved for sale were as follows:—

- Ice-cream
- Beverages (cider, juice, and cola type drinks, etc.) (Alcoholic drinks and chewing gums were not allowed.)
- Snacks (bread, sandwiches, and box lunch)
- Souvenirs etc.
- Cigarettes

Patrolmen made frequent rounds to check and inspect those stands and restaurants. Special efforts were exerted to prevent, with the help of sanitary inspectors, accidents relating to food.

Cleaning

Cleaning programme The period of cleaning was from 15th September 1964 to 25th October, with a few exceptions according to lease terms of games sites. First to be cleaned were places inside the first gates and special attention was paid to latrines and spectators' stands. Cleaning of each room was left to the duty of the responsible person of the room. The labour management for cleaning workers and disposal of refuse and garbages and night soil was assigned to related offices of prefectural governments, towns and cities.

Cleaning works During the preparatory period, cleaning was limited to the area then in use. Overall cleaning operation was carried out a day before the Opening Ceremony. Overall cleaning operation was however carried out every day after the closing of the days' games. Due precaution was paid to inflammables. Waste paper in spectators' stands, and cigarette ashes in rubbish boxes were collected for disposal during the intervals of shifting spectators, whenever possible.

Disposal of rubbish and night soil was assigned to prefectural governments and municipal and

town offices having jurisdiction over the sites.

The organizations concerned adopted a system of early morning collection so that it would not disturb their normal services. An interim collection was also made at the intervals of spectators' shifting.

Exchange Service

For convenience of foreign delegates, athletes and spectators, the following seven banks were designated respectively at the games sites to handle money exchange:—

- (1) The Mitsubishi Bank (National Stadium)
- (2) The Daiwa Bank (National Gymnasium)
- (3) The Saitama Bank (Tokorozawa Clay Shooting Range)
- (4) The Tokai Bank (Komazawa Volley-ball

Special technical or emergency personnel attached to various sports venues

Venues	Period	A	B	C	D	E
National Stadium	Oct. 7~ Oct. 26	10	26	12	2	
Prince Chichibu Memorial Football Field	Oct. 9~ Oct. 21	2	5	4		
Tokyo Metropolitan Gymnasium	Sept. 15~ Oct. 31	4	4	3		
Tokyo Metropolitan Indoor Swimming Pool	Sept. 15~ Oct. 31	4	2	1		
National Gymnasium	Sept. 15~ Oct. 20	5	16	6	1	2
National Gymnasium Annex	Sept. 15~ Oct. 26	3	7	2		
Shibuya Public Hall	Oct. 1~ Oct. 20	4	10	3	2	
Komazawa Stadium	Sept. 15~ Oct. 31	30	53	23	3	
Komazawa Gymnasium	Sept. 15~ Oct. 31					
Komazawa Volley-Ball Court	Sept. 15~ Oct. 31					
Komazawa 1st Hockey Ground	Sept. 15~ Oct. 31					
Komazawa 2nd Hockey Ground	Sept. 15~ Oct. 31					
Komazawa 3rd Hockey Ground	Sept. 15~ Oct. 31					
Equestrian Park	Sept. 15~ Nov 5	10	3	2		
Waseda Memorial Hall	Oct. 1~ Oct. 25	2	2	1		
Korakuen Ice Palace	Oct. 7~ Oct. 26	4	2	2	1	
Nippon Budokan Hall	Oct. 10~ Oct. 30	5	7	3	7	3
Hachioji Velodrome	Sept. 15~ Oct. 27	3	2	3	1	
Hachioji Cycling Road Race Course		2	5	1		
Yokohama Cultural Gymnasium	Oct. 6~ Oct. 24	4	3	1		1
Mitsuzawa Football Field	Oct. 7~ Oct. 19	4	4	2		1
Sagami Bay	Sept. 15~ Oct. 24	3	2	1		
Lake Sagami	Sept. 15~ Oct. 24	4	4	2		
Toda Rowing Course	Sept. 15~ Oct. 27	6	6	2		1
Asaka Shooting Range	Sept. 15~ Oct. 25	4	2	1		
Asaka Nezu Park	Aug. 5~ Oct. 25	1	4	2		
Tokorozawa Clay Shooting Range	Sept. 15~ Oct. 19	4	4	1	1	
Omiya Football Field	Oct. 7~ Oct. 19	4	4	2	1	
Tokyo Univ. Kemigawa Playing Grounds	Oct. 1~ Oct. 16	4	3			1
Karuizawa Equestrian Events Ground	Oct. 15~ Oct. 20	4	2			

A: guards B: electrical engineers C: water supply personnel D: gas supply personnel E: boiler men

Court)

- (5) The Sanwa Bank (Tokyo Metropolitan Gymnasium)
- (6) The Kobe Bank (Korakuen Ice Palace)
- (7) The Sumitomo Bank (Nihon Budokan Hall)

The thoroughness of the preliminary arrangements and the advance training of personnel involved to enable them to cope with any emergency, was rewarded with a smooth and efficient operation at all games sites and very few incidents or accidents were reported. Some complaints were re-

ceived that certain athletes were attempting to gain admission into the venues or sports for which they did not have authorized passes. This problem became most noticeable in the venues in the area surrounding the Olympic Village when a number of foreign athletes attempted to enter the stadium or gymnasium to see their countrymen compete. In some cases actual entry was forced, and the secretary general of the Organizing Committee issued warning against this practice to the Chef de Mission of the delegations concerned.

Ambulances and emergency equipment vehicles placed at each stadium

Venues	No. of days	10th	11th	12th	13th	14th	15th	16th	17th	18th	19th	20th	21st	22nd	23rd	24th	Total
National Stadium	12	8(2)	6(1)			6(1)	6	6	6(3)	6(2)	6(4)	6(5)	6(2)		6(2)	8(4)	76(26)
Prince Chichibu Memorial Football Field	5				2	2		2		2		2(2)					10(2)
Tokyo Metropolitan Gymnasium	6									1	1(2)	1(2)	1(2)	1	1		6(6)
Tokyo Metropolitan Indoor Swimming Pool	7		1	1	1	1	1		1	1(1)							7(1)
National Gymnasium	8		1(1)	1	1(1)	1(1)	1	1	1(1)	1(1)							8(5)
National Gymnasium Annex	11		1(1)	1	1	1		1(1)	1	1		1(1)	1(1)	1(1)	1		11(5)
Shibuya Public Hall	7		1(1)	1(1)	1(1)	1		1	1(1)	1							7(4)
Komazawa Stadium	7		(1)	1	1(1)	1	1	1(1)		1		1(2)					7(5)
Komazawa Gymnasium	8		1(1)	1	1(1)	1		1(1)	1	1(1)	1						8(4)
Komazawa Volley-Ball Court	10		1		1	1	1		1	1	1		1		1		9
Komazawa 1st Hockey Ground	12				(1)				(1)							(1)	(3)
Komazawa 2nd Hockey Ground	10				(1)				(2)	(1)			(1)				(5)
Komazawa 3rd Hockey Ground	9		1	1	1	1	1	1	1	1	1						9
Equestrian Park	2													1	1		2
Waseda Memorial Hall	12			1	1	1(1)	1	1	1	1	1	1	1	1	1		12(1)
Korakuen Ice Palace	12		1	1	1	1(1)	1	1(1)	1	1	1	1(1)	1	1	1		13(3)
Nippon Budokan Hall	5						1					1(1)	1	1	1(1)		5(2)
Hachioji Velodrome	4							2	1		1		1(1)				5(1)
Hachioji Cycling Road Race Course	2					6								5(3)			11(3)
Yokohama Cultural Gymnasium	10			1	1	1	1		1	1	1		1	1	1		10
Mitsuzawa Football Field	6		2	2	2	2	2(1)			2							12(1)
Sagami Bay	7			1	1	1	1				1	1	1				7
Lake Sagami	3											1	1	1			3
Toda Rowing Course	5		1	1	1	1	1										5
Asaka Shooting Range	6				2		2	2		2	2	2					12
Asaka Nezu Park	1		2														2
Tokorozawa Clay Shooting Range	3						1	1	1								3
Omiya Football Field	5		1	1			1	1		1(1)							5(1)
Tokyo Univ. Kemigawa Playing Grounds	1						1										1
Karuizawa Equestrian Events Ground	3							2	2		2						6
Meiji Jingu Baseball Field Stadium	1		(1)														(1)
Marathon and 50 km Walk Race Course	1									(2)			(7)				(9)
Total		8(2)	20(7)	15(3)	19(4)	29(4)	24(1)	24(5)	20(7)	25(9)	19(6)	18(14)	16(14)	13(4)	14(4)	8(4)	272(88)

1. Figures in parenthesis are persons involved.
2. The Meiji Jingu Baseball field was serviced from the nearby National Stadium emergency facilities. Komazawa facilities were also provided by local area emergency vehicles.

TRANSPORTATION

Special Committee

At the 5th meeting of the Organizing Committee held on 26th September 1960, it was decided to establish as a consultative body, a Special Committee on Transportation. This was considered necessary in that it was felt that expert knowledge would be indispensable to meet the special requirements of transportation, especially in such matters as the procedural entry formalities for foreign athletes and officials arriving in Japan, and the entry and clearance of their equipment, and the complicated task of directing transportation to and from the Games venues under the congested traffic conditions in Tokyo.

The first special committee for transportation was placed under the control of the Transportation Section. The Committee was composed of representatives of governmental organizations (Ministries of Transportation, Finance, International Trade and Industry, Health and Welfare, Agriculture and Forestry, National Defense Agency and the Metropolitan Government of Tokyo), as well as the principal officials of the Japan Amateur Athletic Association, the Japan Yachting Association and the Japan Equestrian Federation.

Later, representatives of the National Police Agency and the Metropolitan Police Board were included in the Committee. Two sub-committee were created within the 5th Special Committee and entrusted with the task of procuring vehicles and attending to matters of customs clearance and quarantine. Technical items were reviewed, and the finalized plan was submitted for consideration by the Special Transportation Committee. The sub-committees met in all on 87 occasions for preliminary discussions. The Special Transportation Committee met 11 times, the sub-committee on the procurement of vehicles 4 times, and the Sub-Committee on customs clearance and quarantine 4 times, aggregating in all 19 meetings. Eventually, the number of members of this Committee reached a total of forty, and the diligent manner of their deliberations was in a large measure responsible for the successful transportation arrangement.

Transportation to Games Facilities

Affairs pertaining to transportation to the various games facilities were under the sole control of the Organizing Committee Secretariat under whose

direction questions relating to athletes, newsmen and correspondents, their personnel effects and equipment, were handled speedily and satisfactorily. This was to a large extent made possible by the careful review and extensive preparatory study of the transportation plan, and a due appreciation of the congested traffic conditions and the problems of providing efficient transport to and from the somewhat scattered Games sites.

The Transportation services functioned for the period during which the Villages were open to athletes (15th September to 5th November). Vehicles and planes made use of for this purpose over the 52-day period, numbered as follows:—

Leased buses	5,411
Buses supplied as auxiliary support	1,323
Motor cars leased	12,523
Cars supplied as auxiliary support	9,493
Leased trucks	1,266
Trucks supplied by the National Defense Agency	113
Jeeps supplied by the above Agency	2,461
Helicopters supplied in support by the same Agency	100

Apart from the jeeps, trucks and helicopters provided by the National Defense Agency, the other vehicles were provided on a lease basis from private organizations such as the Tokyo Motorbus Association (48 participating companies), Tokyo Passenger Car Association (79 participating companies), and Nippon Express Company. In addition certain passenger cars with drivers were supplied by six large automobile manufacturers, (Hino, Isuzu, Nissan, Prince, Mitsubishi and Toyota).

To identify the cars being used for the specific purpose of transportation to and from the Olympic sites, each vehicle was provided with the official mark of the Tokyo Olympics, properly displayed either on the front or on the side of the window pane, and also a designated sticker affixed to the pane in front of the driver's seat. This marking afforded these vehicles special treatment both in traffic and in parking.

Organization All matters of transportation were in principal first referred to the appropriate section in the Organizing Committee. Directly under this Headquarters, and Operational Centre was established as a working unit and assigned with the task of maintaining liaison between various points such

where large groups of people connected with the Games would be concentrated. The primary purpose of the Olympic Village at Yoyogi, the various detached Villages, the Press Centre and hotels was the Transportation Headquarters. The main purpose of this Transportation Headquarters was then, not functionally an operation centre, but rather one of control. However, in view of the fact that there was much exchange of information and arrangements to be made on matters relating to customs clearance, entry into Japan, quarantine, etc., of people arriving either by plane or by ship, a separate staff was organized within the Headquarters to specifically handle these questions. A team having at its disposal 430 vehicles (370 cars and 60 minibuses), supplied by the six motor vehicle companies, was placed under the direct control of this Headquarters. In order to meet any possible and unforeseen emergencies, a considerable number of cars were in addition kept in reserve at the Headquarters.

Transportation Headquarters: Under the direction of the Director-General and his deputy, the Headquarters was divided into six teams, each sharing an allotted portion of the work load. The component members of the Headquarters were the 29 personnel from the Organizing Committee Secretariat, 44 temporary workers dispatched to the Secretariat from the Nippon Express Company as well as from various bus and passenger car companies, 49 college students who were sent in as temporary helpers, and 9 interpreters, totalling 131 in all. This staff was not necessarily placed on duty at a fixed place at all times but was diverted to such places or locations as the situation demanded.

General Affairs Team This team dealt with matters of personnel. (wages, keeping of records, and administration of the budget appropriated), for the 271 employees of the Transportation Headquarters and various operational units under its jurisdiction.

Information Team This team handled the liaison with the Tokyo International airport on matters relating to customs clearance, entry and quarantine, and was given the following terms of reference.

(1) To collate and execute information received from the Foreign Affairs Department of the Organizing Committee Secretariat, Athletes' Village Headquarters, Aviation Bureau of the Transportation Ministry and airline companies, arrival or departure of equipment and particularly of persons connected with the Tokyo Games.

(2) Maintaining a station at all times at the Tokyo International airport at Haneda, to receive incoming athletes and officials, to allocate cars for their convenience, and to contact their places of lodging.

(3) To keep liaison and make necessary arrangements regarding the personal effects of athletes, officials, newsmen and correspondents, for customs clearance and quarantine.

(4) To act on their behalf in completing domestic formalities regarding the necessary entry formalities for guns and ammunition.

Operational section (a)

(1) To give direction and guidance regarding duties at the athletes' transportation centre and points of liaison at various detached Villages.

(2) To coordinate with all the organs and units of the Organizing Committee, and control the execution of a transportation plan for the conveyance of persons on the occasion of main events, (such as the opening and closing ceremonies).

(3) To control the operation of cars held in reserve at Headquarters in meeting emergencies or other unforeseen incidents.

Operational section (b)

To give direction and guidance to transport liaison offices on duties relating to the conveyance of officials of the IOC, NOC and the Sports Federation residing at hotels, and the invited guests.

Operational section (c)

(1) To direct and supervise procedures for customs clearance of yachts, boats, canoes and horses (including quarantine) and other matters relating to transportation being handled by the Nippon Express Company.

(2) To receive requests for the supply of trucks from the Villages or from offices at various games sites and to issue relevant orders as required.

(3) To maintain liaison with the Self Defense Agency regarding matters of truck transportation.

Vehicular sections

(1) To allot cars for dispatch to units which exercised operational duties.

(2) To attend to matters of fuelling, maintenance, and control and surveillance of facilities at parking lots.

Part of the grounds of the former Akasaka Detached Palace (33,000 sq. metres) had been designated as a parking lot, and car washing and fuelling stations were established at this site.

To facilitate this implementation of matters pertaining to transportation, 17 liaison points, including the athletes' transport Centre, were established. One of these, the Transport Liaison Office at Haneda, was assigned also the duty of transporting athletes and officials arriving at the port of Yokohama. Matters concerning the operation of shuttle buses within the Olympic Village at Yoyogi were placed under the jurisdiction of the Yoyogi Village.

Each of these operational units had their own

specific transportation plans, held a number of cars in reserve, and performed the required transportation. In cases of unforeseen incidents requiring immediate attention when no transportation was available at the liaison point concerned, contact could be made to the Transportation Headquarters for appropriate direction.

Persons attached to the Organizing Committee Secretariat by bus and taxi companies were put in charge of operations at each and every unit and constituted the main force. Care was taken to ensure that all specific situation were efficiently dealt with. Night-duty was maintained at strategic points of liaison during important periods.

Support by the Japan Self Defense Ground Force: In accordance with an overall agreement for support, two groups were organized, one in support of ground transportation and the other for air transport. Headquarters were established at the Athletes' Village and at Ichigaya (Tokyo Olympic Supporting Corps) respectively. The organizational setup and duties of these groups were as follows:—

Transportation Supporting Corps

(1) Transportation Battalion at Village

a. Squad of jeeps

Operation and control of jeeps allotted for the use of each chief of mission.

b. Bus Transportation Supporting Corps

Operation of leased buses running to and from the terminal at the athletes' Village in accordance with the plan of the Organizing Committee Secretariat.

(2) Truck Transportation Supporting Corps

This was an auxiliary transportation facility by trucks on lease to the Organizing Committee Secretariat and used for transporting material and equipments between the athletes' Villages and Games sites.

(3) Communications Corps

This corps, as a mobile unit, was assigned to liaison, by wire and wireless equipment, between the Transportation Headquarters and the various working units.

(4) Supervisory Corps

Replenishment of supplies and maintenance of vehicles.

Air Supporting Corps

(1) Transportation by helicopter of officials and news personnel connected with the general operations of the Games.

(2) Transportation of patients in case of emergency.

Personnel composition:—

The total number of staff engaged at the various organizational facilities under these headings numbered 1,201 as follows:—

Personnel at the Organizing Committee Secretariat	35
Temporary employees loaned by Nippon Express Company, bus and taxi companies	106
Student helpers	79
Interpreters	51
JNDS Ground troops in support of transportation	867
Air supporting group	63
Total:	1,201

Transportation of personnel connected with the Games A systematic programme for transporting Games officials and personnel to the various sites of the Games was worked out in accordance with the following classifications.

- Transportation at time of arrival
- Transportation to training and Games sites
- Transportation for participation in official functions, such as the opening and closing ceremonies, international conferences and receptions
- Transportation at time of departure

Special measures were taken for the convenience of foreign athletes using buses or taxicabs in that most would be unfamiliar with the local geography. It was further planned to use helicopters in emergencies.

Allotment of vehicles: The allotment of vehicles was made on the following basis.

Athletes Large buses were mainly used for transportation at the time of arrival, for transportation to and from training sites, for participation in the opening and closing ceremonies, and to the Games sites. Depending on the road condition and the number of persons, minibuses were used in some instances.

Chiefs of Mission A car was provided to each chief of mission.

Officers of Athletes Delegation Cars were provided for exclusive use of each delegation in proportion to the number of athletes, as follows:—

Less than 10	0
From 11 to no more than 50	1
" 51 " 100	2
" 101 " 200	3
" 201 " 300	4
" 301 " 400	5
" 401 " 500	6

News men News men attended all the main events and, therefore, were treated for this purpose in the same manner as athletes. For transportation from the Press Centre to the training sites and to the Games, both bus and passenger cars were used. Applications were required to

be filed in advance for passenger car allotment. During the period 6th to 24th October, one or two cars were in addition provided for the exclusive use of the eleven foreign news agencies.

Specially invited guests Passenger cars were provided for the exclusive use of each guest.

Members of the International Olympic Committee Passenger cars, distinctively marked with the Olympic symbol, were provided for the exclusive use of each IOC member in Tokyo.

President, Secretary General of International Sports Federations There again cars for their exclusive use were placed at the disposal of each sports Federation.

Officials of International Sports Federations Cars were allocated under this heading depending on the number of officials and the type of event.

International Judges and Referees For transportation to the events concerned buses were provided from the place of lodging, (which in most cases was the Daiichi Hotel) to the respective games venues.

National Olympic Committees Regardless of

the number of officials, one passenger car was provided for the exclusive use of each individual member of any National Olympic Committee present in Tokyo.

Allotment of vehicles: Apart from the cars allocated under the above headings, cars were also provided for various other uses as enumerated below:—

- Transportation of pigeons, national emblems and musical bands to the Olympic Stadium.
- Transportation of officials connected with exhibitions of 'Kendo', Archery, 'Sumo' and baseball.
- For use by offices at the various sports venues of the Olympic.
- For the Japan Federation of Sport Sciences.
- Japanese Athletic organizations (restricted however to those organizations included in the Olympic events.
- IBM Centre.
- Departments and sections of the Organizing Committee.
- Olympic Village at Yoyogi (including shuttle buses within the Village).

Buses lined up in the parking area, Yoyogi Olympic Village are ready to transport athletes



- Medical and hygiene clinics within the Village.

Transportation of equipment, apparatus and horses

The Nippon Express Company had been officially appointed by the Organizing Committee on 2nd October 1962 as the sole agent to handle affairs concerning good transportation. This company then formed its own section to study the likely problems involved and selected men of special capability from among its nation-wide branch offices to study matters of customs clearance and quarantine.

At the peak time when the personal effects of athletes and officials, as well as equipment and apparatus were being transported, this company had mobilized approximately 900 men each day, and the work was accomplished under the overall control of the Transportation Headquarters.

Transportation of boats, yachts, canoes and horses

Transportation of boats, yachts, canoes and horses that required special handling had been brought into Japan via sea and air routes. In all 144 horses, 114 boats, 81 yachts and 112 canoes were

included. The majority of the horses had been shipped in by air whereas, boats, yachts and canoes that are of long and bulky measurements were mostly brought in by sea. (See table)

Most of the equipment was landed either at Yokohama (sea) or the Haneda airport (air), though due to shipping schedule in some cases, some of the horses and equipment and games materials were landed at the ports of Kobe, Nagoya and Niigata.

There were several examples of goods which were brought in by other transportation or which arrived at other ports than these (including a boat and a canoe belonging to the North Korean team landed at the port of Osaka; 2 boats of the Italian team, at the port of Nagasaki, being laden aboard a ship of that country).

The equipment, apparatus and games materials generally arriving earlier than athletes coming in by air, and a bonding warehouse at the waterfront of the port of Yokohama was leased, and a building was exclusively used as the point for transshipping those goods. As it was expected that a large volume of requests for return shipment would

Ample jeeps were allotted to the participating teams for transporting bicycles during the Team Road Cycling competition in Hachioji





Equipment such as boats for rowing were transported by truck directly to the Toda Rowing course (above), and unpacked (left)

be made, with the added factor that whatever goods received for shipment would have to be held stored until the time of availability of shipping, a building in the rear was specially leased which was used as a bonding warehouse.

Transportation of various materials Trucks which had been selected for convenience in transporting goods covering short distances, had been in use day and night for various transportation requests (carriage of pigeons and banners required at time of opening and closing of ceremonies; equipment, furnitures and goods of consumption needed in the opening of games; various materials needed for the control and operation of the games such as traffic signs, ropes and others, inclusive of bicycles and gift donations and also the personal effects carried by the athletes).

The number of vehicles and personnel that the Transportation Headquarters had directly allotted and supplied in answer to requests made by the

relative departments and sections totalled 1,258 vehicles and 4,329 persons. In these were included 113 vehicles that had urgently been used for transportation by trucks supplied by Transportation Support Section. In addition some 719 vehicles and 5,466 persons had been employed for transporting materials needed for maintaining order in events such as marathon, walking races, bicycle road races and for opening and closing ceremonies.

Insurance and Accidents All vehicles, regardless of whether leased or supplied, were covered by a compulsory accident liability insurance as required under the Japanese law, so no special or additional vehicle insurance coverage was arranged for the vehicles used during this period. Both the bus and taxi associations, in precaution for any major accident that might occur involving not only the officials and athletes but foreigners in general, had provided for themselves special insurance coverage

Equipment shipments arriving from overseas for delegations

	No.	Country	Port of arrival	Internal handling
Horses	4	New Zealand	Kobe	Road transport
	5	Australia	Nagoya	"
Yacht	1	New Zealand	Kobe	"
	1	Bahamas	Niigata	Railway truck
Rowing Canoe	1	North Korea	"	"
	1	North Korea	"	"

Transportation of boats, yachts, canoes and horses

Sports	Type	by Sea		by Air		Others	Total	
		Arr.	Dep.	Arr.	Dep.		Arr.	Dep.
Rowing	Eight	14	16	2		1	16	17
	Four	33	35	2			35	35
	Pair	29	30	1			30	30
	Double Scull	13	17	4			17	17
	Single Scull	14	16	2			16	16
	Total		103	114	11		1	114
Canoeing	K 1	35	36	6	5		41	41
	K 2	24	25	5	5		29	30
	K 4	11	12	2	1		13	13
	C 1	14	14	1	1		15	15
	C 2	13	13	1	1		14	14
	Total		97	100	15	13		112
Yachting	5.5 m	13	14	1			14	14
	Dragon	20	20	1			21	20
	Star	14	15	1			15	15
	Flying Dutchman	21	21	1			22	21
	Finn	8	9	1			9	9
	Total		76	79	5			81
Equestrian Sports	Horses	40	44	104	98	1	144	143

Discrepancies between arrival and departure figures were brought about by teams disposing of or purchasing equipment either among themselves or with Japanese Sporting Federations.

at their own expense.

No accident's however involving physical injury occurred during the period of the Games, excepting some minor cases of vehicle collision. This safety period can be credited to the efforts exerted by both the personnel placed in charge and the operators of vehicles, and was an extremely good record considering the fact that some 32,000 vehicles had been operated under the congested condition of traffic.

Volume of luggage handled

Arrival (by Air)	16,697 items
Departure (by Air)	14,803 items
Total	31,500 items

Number of aeroplanes involved

Arrival (Sept. 11—Oct. 11)	Scheduled flights:	630
	Charter flights:	53
Departure (Oct. 16—Nov. 5)	Scheduled flights:	420
	Charter flights:	45



Horse arriving from overseas

Customs Clearance and Quarantine

Considerable attention was given to adequate arrangements to afford smooth customs clearance and quarantine facilities, in that this would be the first impression which arriving athletes and officials would have of this Games organization.

As the result of efforts made on the part of the relevant sub-committee and with the very active cooperation by the governmental organizations concerned, a part of the applicable law had been amended for the period of Games and directions were issued to allow the authorities concerned to follow a simplified process in the matter of procedures involving the visitors and their baggage and personal effects.

The Organizing Committee in accordance with this arrangement, had prepared tags or labels to be put on the hand-baggages and separate parcels,



Athletes luggage was all individually weighed

as well as on materials needed for the Games to distinctly indicate that they belonged to the athletes. A simplified declaration form that would be required at time of customs clearance was also prepared and forwarded to the participating nations, respectively. At the same time, handbooks and pamphlets were prepared, indicating the occasion when they would be needed and how they should be filled in. These had been sent out ad-

Athletes completed immigration formalities, simply, before leaving the village



dressed to the respective NOC's and to the ISF's involved and for the newsmen and reporters concerned, through the Japan Broadcasting Corporation and through the press department of the Organizing Committee.

To facilitate clearing and customs formalities for goods and luggages belonging to the athletes, a new building was put up within the Olympic Village at Yoyogi where quarantine of animals and plants was also made.

In order to ensure that the athletes could begin training from the very day of their arrival, customs clearance and quarantine was carried out at the place where the goods would be used (at the Toda Rowing Course, the Boat Racing Course at Lake Sagami, Enoshima Yacht Harbour, the Equestrian Park and Karuizawa).

Executing in proxy the procedural formalities for import of rifles and ammunition

For import of rifles and ammunition, a list on a prescribed form of report was obtained from the groups of athletes of the respective countries participating. The Organizing Committee based on the reports so received, filed applications to the Government offices concerned requesting the necessary permission for import of rifles and ammunitions, and for permission to possess such firearms. As rifles and ammunition are items strictly controlled under Japanese law, the teams of athletes upon their entrance into Japan, were required to agree in writing that the firearms so admitted would be re-exported. However, all procedure in this respect was executed very smoothly, and no inconvenience appears to have been experienced as a result of these strict regulations.

Rifles and ammunition that were admitted for the Games were as follows:—

Number of participating countries in Shooting, Modern Pentathlon	51
Number of athletes involved	295
Pistols brought in	210
Rifles brought in	138
Shot guns brought in	80
Number of countries brought in ammunition	43
Total rounds of ammunition involved	453,790



Members of the USSR Team arriving at Tokyo International Airport

Participants from Canada





Yachts being unloaded at Enoshima

Baggage labels to prevent confusion





Horses which travelled by air

Simplified customs formalities for arriving participants (Here a Jet Hangar is used to assemble baggage of a newly arrived group)





(above) Buses lined up outside the main gate of the Olympic Village (right) Members of the Japanese Team board the bus



Stickers used to distinguish the various bus destinations



SECURITY AND TRAFFIC CONTROL

Outline

Security and traffic control during the Games of the XVIII Olympiad had to be administered under conditions other than ideal. This problem is one of some magnitude even in normal times in Tokyo with its more than 10 million population and the one million registered motor cars which make in total average daily runs of 5,200,000. The organization during the games was complicated by Marathon, Walking Race and Cycling Road Race events which were held on busy highways, and also by the fact that many of the other sports were required to be conducted at venues located at considerable distances from the Olympic Village.

In spite of these difficulties however, it was imperative to provide adequate security and traffic control, for without that, the successful administration of the Games of the XVIII Olympiad would be impossible.

To this end, the Organizing Committee drew up safety and traffic control measures after diligent study and consultations with the relevant authorities of Police, the Ministry of Transportation, the Maritime Safety Agency, Prefectural and other organizations concerned. The overriding principle in all these deliberations was to secure safe and orderly traffic flows of the public in and around the Games sites as well to provide orderly movements to and from the various venues. The measures which were placed under the responsibility of the Police force were as follows:

- (1) Traffic management during the Olympic Torch Relay.
- (2) Policing of the crowds at the National Stadium, both inside and outside, during the Opening and Closing Ceremonies.
- (3) Security at all venues, both inside and outside.
- (4) Police controls on roads used for Marathon, Cycling Road Race and Equestrian Three-Day event.
- (5) Traffic control on the roads in the vicinity of Games sites.
- (6) Management and operation of parking areas.
- (7) To provide safety and punctuality in transportation of athletes and officials.
- (8) An overall planning of public transporting requirements.
- (9) Security measures at the Olympic Village.

The Organizing Committee provided publicity concerning the relevant measures and also installed necessary equipment and facilities. The Organizing

Committee itself assumed responsibility for securing parking areas and for equipping them with necessary facilities. It also issued car stickers to vehicle owners to define their eligibility to the parking lots. Although there had been early apprehension, the various programmes under these headings were conducted satisfactorily and without incident—indeed the efficiency of this control was the subject of favourable comment from visitors. The effective implementation of these measures was due in no little degree to the willing cooperation of the public and the organizations involved.

Organization of Security and Traffic Control

The Organizing Committee had set a Security and Traffic Division, and to this division was assigned the overall management of police and traffic control. This division of the Organizing Committee was required to perform all the preparatory requirements before the Games and conducted consultations and solicited the cooperation of the police force.

The Organizing Committee maintained field offices in all of the Games sites. Its security and traffic control officials assisted the office head in maintaining liaison with the police authorities and other organizations concerned at each venue, in the management of parking lots, administration of security and traffic control equipment, handling of lost articles.

The Organizing Committee, also appointed a special sub-committee (Traffic and Security Committee). This Committee included responsible persons of organizations concerned, scholars and men of experience, and it was charged with the study of matters pertaining to the overall programme. Consultations were held as required, with the organizations concerned, especially the police, and close liaison was assured by holding regular meetings twice a month from the beginning of 1964.

Traffic Control Around the Games Sites

This was one of the most important and difficult problems at the time of the Games. The Metropolitan Police Headquarters had conducted continuous studies and surveys on this matter and had finally prepared a basic plan to adopt. Some examples of the steps involved would include:



The main road leading from the Imperial plaza is cleared of traffic for the passing of the Torch Relay, as spectators

—Around the Meiji Olympic Park where the National Stadium (the main venue for the Tokyo Olympic Games) and other venues are situated, two encircling control routes were set up. All traffic within these areas were subjected to prohibition of parking and one-way traffic. On the inner encircling route, ordinary traffic was completely prohibited and no cars other than those bearing official stickers issued by the Organizing Committee were permitted to enter or park in the areas during the major period of the Games. The outer encircling route was enforced only on the days of the Opening and Closing Ceremonies and no trucks except those official vehicles with stickers were permitted to enter these areas.

—In areas around other venues, one-way traffic control, prohibition of parking or suspension of traffic was enforced according to the requirements at that site. The forward planning and strict control under this heading was rewarded by orderly traffic being maintained throughout the days of the Olympic Games. The Organizing Committee issued stickers to car-owners living in those areas and to those vehicles on official duties for the Games. The number of stickers issued were as follows:

Meiji Olympic Area	2,604
Komazawa Sports Park Area	766
Yoyogi Sports Centre Area	1,041
Toda Rowing Course Area	300
Enoshima Yacht Harbour Area	300
Nippon Budokan Hall Area	316

Police Control on the roads for the Olympic Torch Relay

The Olympic Torch Relay was most enthusiastically received everywhere it appeared, and an estimated total of 28,700,000 spectators lined up on

the various routes it passed. The number of police man-days involved in policing and traffic control for the Torch relay totalled 91,237.

In each Prefecture concerned, a Torch Relay Committee was organized to select the runners, the torch relaying points and the actual course which the relay would take in that area. The police authorities in each Prefecture sent representatives to this Committee, to assist on matters of security and traffic control for the torch relay. The Organizing Committee also despatched officials to strategic points to ensure smooth performance of the Torch relay.

Certain sections of the routes selected for the Torch relay had to be changed because of a typhoon at that time. This change did not cause any delays however and the final runner on 10th of October arrived on schedule to light the Sacred Fire, with the flame carried by relays of torches all the way from Greece, amid the roaring applause of the 75,000 spectators at the Opening Ceremony of the Games of the XVIII Olympiad, Tokyo.

Police and Traffic Control on the Days of Opening and Closing Ceremonies at the National Stadium

It had been estimated that about 75,000 spectators would be in the National Stadium on the days of the Opening and Closing Ceremonies. In addition a further 100,000 interested spectators were expected to assemble in the area around the National Stadium. Their Majesties the Emperor and Empress of Japan and members of the Royal Family, and other dignitaries would also be present, and accordingly ample security and traffic control would be essential. The parading marches of the many athletes and officials of the participating nations,



crowd the footpaths on both sides.

and the passage and entry of the Torch relay into the stadium all had to be carefully planned and executed with precision timing. After the ceremonies, this enormous crowd of people would pour out into the streets around the National Stadium and to the nearby stations on their way home. This could create an unforeseeable congestion around the Meiji Olympic Park unless most detailed preparations had been implemented to deal with this volume of traffic.

Thorough studies were made on the specific actions to take on the day of the Opening Ceremony.

Overall traffic control The two encircling routes (inner and outer) were set up around the Meiji Olympic Park to ensure perfect control. Within the areas encircled by the inner circling route, cars without stickers issued by the Organizing Committee were not permitted to enter during the hours from 10:00 to 16:00. Within the areas of the outer circling route, trucks without stickers were not prohibited to enter from 12:00 to 16:30 hours. It was due to these careful preparations, the pre-Olympic publicity campaign, and the cooperation of the public in general and the car-owners in particular, that traffic on the streets in those areas was efficiently maintained, and the transportation of athletes, officials and spectators was conducted in an exemplary manner without any incidents whatsoever.

Specific routes for entry and exit of vehicles related to the Games Specific routes were selected for the cars of personnel qualified under Article 48 of the Olympic Charter and officially invited guests, taking into consideration the concentration of people around the venues, the transport situation and the various Olympic events. Precision timing was

used in having these official cars move over pre-arranged routes, and by ensuring that those cars arrived after those buses transporting the athletes and officials, congestions of vehicles was averted. The commemoration ceremony for the 70th anniversary of the International Olympic Committee was held in front of the main gate of the National Stadium after the Opening Ceremony on that day. This actually contributed to the smooth and orderly movement of the home-going spectators after the Opening Ceremony, inasmuch as it was not necessary to reserve routes for the official vehicles of the Olympic Committee members, as they remained in the stadium area for the additional ceremony.

Traffic control for transporting athletes and the passages of their parade marches One of the most important matters of policing and traffic control on the occasion of the Opening Ceremony was the task of transporting the athletes from their Olympic Village to the assigned area and also to make sure of their unhindered passage in their parade marches from the assigned place to the National Stadium. Care was taken in planning so that the athletes would be transported in a minimum of time so that there would be no periods of unnecessary waiting or long periods of tiring travel. The control measures under this heading included:—

(1) The athletes would be transported by buses in as short a time as possible from the Yoyogi Olympic Village to the assigned place. Police cars would head their buses to assure uninterrupted passage.

(2) The plaza in the Meiji Olympic Park would be assigned as the assembly place of the athletes.

(3) The parade marches of the athletes would proceed through the route starting from the assem-



Mounted police assisted in traffic control

bly point by a direct route to the Sendagaya Gate of the National Stadium.

The plan was made to transport an estimated 7,500 athletes by 188 buses, taking two separate courses, Course A was 4.1 km and Course B 3.3 km. The athletes were divided into two groups and transported by 94 buses each, taking these two courses mentioned above, and timed exactly so that each bus arrived at regular intervals precisely as the athletes from the previous bus had alighted. The actual number of the athletes participating in the parade was 6,500 on that day, and their transportation was conducted as planned. The transport began at 12:33 hours and ended at 13:06 hours, thus completing the entire movement in only 33 minutes.

Olympic Torch relay course On the day of the Opening Ceremony of the Games, the relay team of the Olympic Torch was directed to take the course from the Imperial Palace plaza (its starting point) to the Aoyama entrance, thence over the same course taken by the parade march of the athletes. This measure was arranged for the benefit of the immense crowd of people who wished to see the Olympic Torch outside the Stadium without moving from the place where they had watched the athletes' parade, and therefore preventing unnecessary congestions.

Returning route of the athletes The athletes were divided into two groups on their way back to the Olympic Village, and in the same manner as their drive to the stadium, their through passages was assured by a police car which preceded them.

Control of spectators after the Opening Ceremony Special measures were taken in order to alleviate as far as possible the sudden exit of 75,000 spectators from inside the National Stadium and the huge crowd of viewers expected outside the National Stadium, and their movement to nearby stations after the Opening Ceremony. These measures included the brass band music at the National Stadium

and the display of fireworks outside the National Stadium to divert the attention of sections of the crowds. These performances proved quite effective in preventing confusion, in that a large number of people both inside and outside the Stadium paused for a short while to enjoy the performances and this slight delay enabled the differentiating in their time of arrival at the stations.

Traffic control on the day of the closing ceremony was conducted in a similar manner The number of athletes participating in the Closing Ceremony was estimated at 4,000, fewer than that on the Opening day. They were all transported by 99 buses in a period of 21 minutes, from the Olympic Village to the National Stadium. It was arranged that after the Closing Ceremony the athletes and officials would go by foot along a reserved route to the nearby Shinjuku Gyoen Park to attend a farewell party. After the party, they were transported by buses back to the Olympic Village. The entire movement was conducted smoothly and without incident.

Police and Traffic Control in and around the Games Sites

Provision was made in the planning for the fact that the spectators would include many persons, including foreigners, who were unfamiliar with Tokyo, and it was recognized that efficient traffic guidance, control and policing inside and outside the site would materially affect the operations of the Games.

Provisions for emergency and incidents It had been arranged that the chief of the Games Administration Office would be first responsible for the handling of any incident on the games venue or arena, and the chief of the field office would be first responsible for the handling of any trouble occurring in the viewers' stand and surrounding area. Only when the trouble was such that it could not expediently be handled in this way, would a request for police assistance be made. Fortunately, however no trouble of a nature that required police action took place during the entire period of the Games.

Guide-Signs and assistance taken for spectators Guide-signs for spectators were installed at each key point around every game site. At the entrance to the areas such as Meiji Olympic Park or Komazawa Olympic Park where many facilities were established, and at the square in front of the nearby railway stations, guide-signs showing the whole facilities of the area were erected. A total of 250 guide-signs were made of triangular-shaped steel

Event	Date	Weather	Nationalities involved	Number of participants	Spectators	Security personnel involved
Marathon	21 Oct.	Cloudy	35	68	1,200,000	12,343
50 km Walk	18 "	Rainy	19	34	160,000	7,472
20 km Walk	15 "	Fine	15	30	5,000	618
Cycling						
Individual Race	22 "	Cloudy	35	132	58,600	1,236
Team Race	14 "	Rainy	33	132	56,000	1,697
Cross Country	18 "	Rainy	12	48	25,500	437

plate painted in a colour assigned to each game site, making it easy to distinguish the site. On the upper part of the sign plate was the symbol of the game, while the name of the site was painted with an arrow sign showing the direction to the particular game site.

Publicity of Police and Traffic Control Publicity campaigns for police and traffic control were conducted on a broad basis. Radio and television broadcasting was used as well as newspapers and leaflets for this purpose so that traffic from persons not directly concerned with the Games was reduced to a minimum on those days. Spectators were advised to go into the games sites early to avoid any congestion, and were urged to as far as possible use public transportation instead of private vehicles. The leaflets issued totaled as follows:

Police and Traffic Control Handbook	55,000
Guide Map to Games Sites	300,000
Posters, Leaflets concerning traffic control	1,200,000
Sign boards	12,000

Handling of lost articles The lost articles handled by the policing and traffic control personnel at all sites during the entire period of the Games were as follows:

Number of cases handled:	1,159
Cash	¥298,430 (US\$ 828.97)
Articles	1,236 items
Recovery to owners:	141 cases
Cash	¥121,231 (US\$ 336.75)
Articles	165 items
Articles turned over to Police Authorities	
Cash	¥177,200 (US\$ 492.22)
Articles	1,071 items

Police and traffic control on Road Games

The games such as Marathon, 20 km and 50 km Walks, both the team individual pursuit Cycling Road Races and events of Equestrian Sports at Karuizawa had to be performed on the public roads. The first problem encountered was the selection of roads from the standpoint of police and traffic control. After careful studies and deliberations, the Koshu Kaido Highway was selected from among six proposed routes for the Marathon course, 42,195 km in total, and the walking course, 50 km in total, both to start from the National Stadium. Security

measures were required to be taken for the athletes, and the spectators on the road sides. Appropriate steps were taken to minimize the possible inconvenience from traffic controls in the area.

To meet these requirements, a special committee was organized by representatives of the Athletic, Cycling, and Equestrian Sports Associations; Metropolitan Police Board; City and town authorities; and organizations and agencies related to road and transportation management. After a series of deliberations and studies, the Committee mapped out practical measures and held some three rehearsals on the problematic police and traffic control for the Marathon race.

On the day of this Marathon race, the spectators exceeded one million along the route. The entire course was kept cleared, and this race ended in a glorious new world record under the most ideal of traffic control conditions.

The 50 km Walk was held without incident, despite the cold rain on that day. The traffic control on Cycling Races had to be conducted for a fairly long period at some places. Thanks however to the pre-publicity campaigns on those measures, and the cheerful cooperation of the public, the races were completed without a single delay. The Equestrian Sports (particularly the three-day events) held at Karuizawa were required to pass over considerable distances of public roads. These were performed most efficiently under perfect traf-

Patrol cars and police escort for the Torch Relay



fic control, again due to cooperation of the local people and the police authorities concerned.

For the Yachting races, cooperation was obtained from the Maritime Safety Agency, and measures were effected for the clearance of boats away from the race area, prevention of accidents, and safety measures for yacht crews, and the public, and in particular in providing special guard services for Royalty. A total of thirteen patrol boats were despatched from the Agency. Thanks to this co-operation, and the fine weather, races were executed smoothly, efficiently and without incident.

Guard and traffic control around the Olympic Village

Emphasis was given to the guard operation around the Olympic Village, and the affairs within the main Village at Yoyogi was managed by the Organizing Committee with cooperation rendered by members detailed from the Ground Self-Defense Force or, in the case of the women's village, police women. Most careful planning of the guard operation of these villages was worked out in every detail.

The guard operation around the Main Olympic Village at Yoyogi was conducted by 136 policemen and 32 policewomen.

Detached villages were also provided with police forces.

During the entire period of the Olympic Games, three officers despatched from the Security and Traffic Division were assigned to the Main Olympic Village at Yoyogi, who under the direction of the Village Director, maintained liaison with the respective police agencies or handled matters of lost or found articles as mentioned below:

Number of cases handled:	327 cases
Cash	¥153,691 (US\$ 426.91)
Articles	296 items
Number of cases of recovery:	44 cases
Cash	¥102,000 (US\$ 283.33)
Articles	44 items

Police and Traffic Control at the training venues

Eighty training venues were provided for the athletes of the Villages. Some of these however were located far from the Main Olympic Village, and provisions had to be made for securing transportation for the athletes and also for parking lots. Preparations were particularly required for the training of Marathon and Walk Race and Cycling Road Race, inasmuch as public roads were involved for comparatively long periods at a time. The police and traffic controls were conducted for those training venues on more or less the same basis as the actual races, as shown below:

- (1) Limitation as to time and date of the training.
- (2) Limitation as to the place and course of training.
- (3) On these roads and places, priority was given to their training performances over all other public traffic.

Police were placed along the roads during the training, and no trouble or incidents whatsoever were recorded under this heading.

Transportation of Athletes, Officials and Others

Personnel connected with the Games Specific routes for the safe and speedy transportation of the athletes, officials and other personnel connected with the Games were designated, after due consideration of the traffic situation and conditions of each road concerned.

The routes thus selected were:

- (1) From the Main Olympic Village at Yoyogi to the Olympic Games Sites
13 routes leading to 23 sites in a total coverage of 336 km.
- (2) From the Main Olympic Village to Training Venues
50 routes leading to 80 training venues, a total coverage of 600 km.
- (3) From Daiichi Hotel (officials accommodation) to each of the Games Sites.

Organizations and agencies concerned were requested to maintain and repair the roads involved. Police authority also provided a special traffic control on the routes to ensure efficient and unhindered transportation.

The guiding and control for their transportation was conducted in respect to public traffic conditions, but emergency traffic control was actuated wherever considered necessary.

The passages of athletes and officials from the Olympic Village to the National Stadium on the days of Opening Ceremony and Closing Ceremony were led by the patrol cars of Police Agency to and from the Stadium. Their passages from detached villages were led only on their way to the Main Village at Yoyogi.

Patrol cars were not in every case supplied for the passages of athletes, during their training periods, except for the volley-ball teams, which had a considerable distance to travel.

Official cars were not escorted by public patrol cars except in emergencies.

The police cars which had led the passages of buses and cars of the athletes and officials from the Olympic Village to each of the Games sites totaled as follows:

Total Runs	578
Number of Cars and Buses	1,286

Number of Athletes

28,934

The transportation of foreign visitors received special consideration. A total of nine bus routes from Harumi Pier, Tokyo Station, Haneda Tokyu Hotel and other hotels to the bus centre, and fourteen bus routes from the bus centre to the various Games venues were organized, in all covering a distance of 95,765 km. The total number of passengers carried amounted to 35,900 during the Games period.

Parking

The most rapid increase in recent years of the number of automobiles in use had accentuated the problems of parking at the time of the Tokyo Olympic Games. The Organizing Committee set up a special sub-committee which defined its basic policies as follows:

(1) Establishment and improvement of Parking Lots

In principle, parking lots with a sufficient capacity to accommodate all cars would be established and maintained at each Games site. If this proved impracticable, parking lots would be established either on a permanent or temporary basis in adjacent areas within a walking distance of 30 minutes. Where it was not possible to accommodate all of the vehicles required in those parking lots, restrictions would then be imposed on the vehicles in the order of priority.

(2) Operation and Management of Parking Lots

An estimation would be made of the number of vehicles to be parked at each of the Games sites. Stickers would be issued indicating the parking lot to which each authorized car had been assigned.

(3) Publicity Campaign

General spectators would be advised to use public transport facilities such as the National Railways, tramcars and public buses inasmuch as the parking capacity would be limited.

Establishment and Improvement The existing parking lots at the Games sites being inadequate, new or enlarged parking facilities were required to be provided. Areas within a 30 minutes walk to the venue were inspected and where possible temporary parking lots were arranged in school grounds, parks, and the open spaces underneath elevated highways. School grounds, of course, could not be used for long periods of time and were accordingly made use of only on the days of the Opening and Closing Ceremonies of the Games.

A total of 106 parking sites were provided with a total parking capacity of 13,563 vehicles at one time. All the temporary parking areas were equipped with the necessary facilities, such as parking

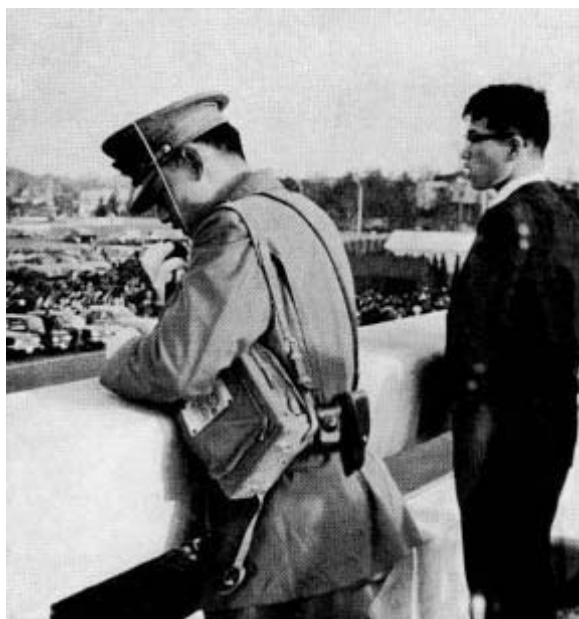

Walkie-Talkie facilities aided police communication

marker lines, signs, control offices, loud speakers, lighting facilities, and lavatories.

Operation and Management Operation and management of parking areas were under the control of the respective field office and under the direction of the Security and Traffic Director. Parking lots not administrated by a field office were placed under the direct management of the Security and Traffic Division.

College student workers were assigned to the operation of parking lots in cooperation with the police authorities, and were distributed on the basis of 1 person for each 30 cars. A total of 8,901 of this temporary help was used throughout the period of the Games.

Period and Scope of the Operation Parking lots at the Games site, Olympic Village, hotels of the officials, Press House, Tokyo International Airport, were operated during the period of 15th September, the Opening Day of the Village, to 5th November, the Closing Day of the Village.

Stickers Parking stickers were issued by the Organizing Committee to officials stipulated in Article 48 of the Olympic Charter, and to officials and personnel related to the operation of the Games and the spectators groups who used chartered buses. The stickers were classified into four classes—the First Class had five divisions A, B, C, D, and E and these stickers defined the parking classification at all parking areas. The Second Class stickers limited parking to a specified games site. The Third Class

permitted parking only on the days of Opening and Closing Ceremonies, while the Fourth Class allowed the vehicle to pass through restricted routes.

- A—Chiefs of state and their suites; members of IOC and their families.
- B—President, Secretary General of IFSs; and their families; members of NOC; Chiefs of Mission; attaches; OOC members; judges; officially invited guests and others approved by the Organizing Committee.
- C—Athletes; Games' officials; and business personnel connected with the operation of the Games.
- D—Buses for student groups or carrying foreign visitor spectators.
- E—Press-personnel; camera men; TV and radio reporters and engineers.

Stickers were easy to remove and made of vinyl sheet without adhesive. Sticker recipients were also supplied with guiding maps of designated parking lots and were given instructions to facilitate their use. The number of stickers issued totalled as follows:

1st Class	2,327
2nd Class	7,944
3rd Class	2,239
4th Class	5,327

Utilization of Parking Lots The strict control of all vehicles near each venue and the efficient ad-

vance planning eliminated any confusion in allocation of the parking spaces available. In fact the available facilities were not used to capacity.

The rate of utilization was 76.3% on the day of Opening Ceremony, 48.3% for the Closing Ceremony and 60% during the period of the Games programme.

Supplies Materials Used

Various kinds of supplies and materials were requested in connection with police and traffic control operations throughout the entire period of the Games, and particularly on the days of Marathon, Walking Races, Cycling Road Race, the Opening and Closing Ceremonies and for the Torch relay. The actual supplies and materials used during the Games under this heading were as follows:

Materials	Quantity
Pipe Barriers	7,772
Rope	(12mm, 16mm) 199,200 metres
Rope Suspender	1,415
Traffic Signs	4,153
Safety Beacons	4,690
Traffic Barriers	502
Traffic Horse indicators	100

Pipe barricades and rope were useful adjuncts to traffic safety





Some of the uniforms used during the Tokyo Olympic Games

Left—Organizing Committee personnel, centre—interpreters, right—sports officials

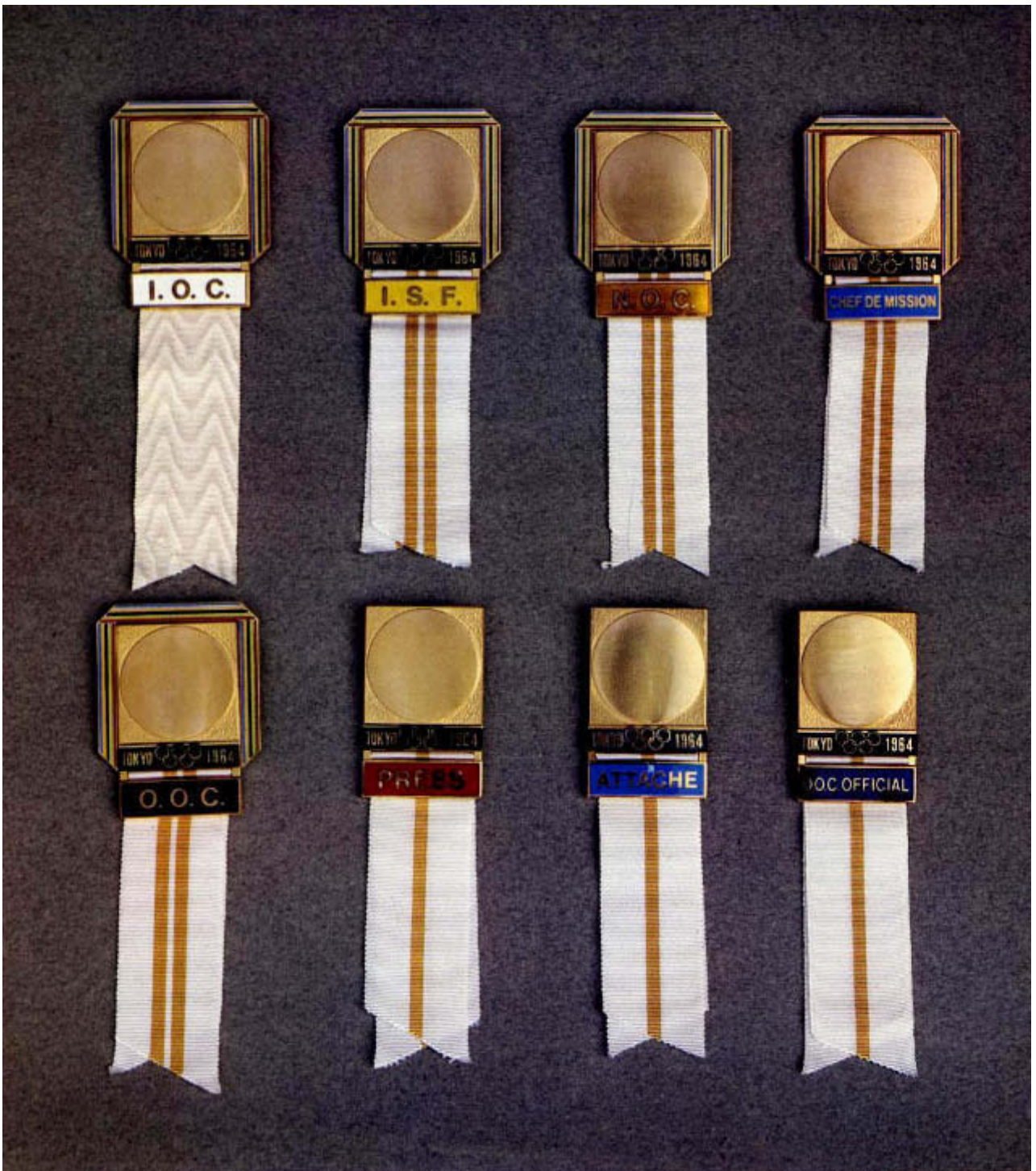

Badges used during Tokyo Olympic Games



The various ribbon colours identifying the various classifications of participants



Sheets of Design Guides showing the correct proportions for the various symbols



The Insurance Policy issued by a group of Japanese insurance companies covering participants in the Tokyo Olympic Games

GENERAL ADMINISTRATIVE AFFAIRS

Designs used for the Games of the XVIII Olympiad, Tokyo.

The policy concerning the designs for use during the Tokyo Olympic Games was to keep them functional as well as decorative. Emphasis was given to the visual communication language of the Olympic events symbols, and the application of colour for both events and areas. This was considered of particular importance in view of the number of nationalities and languages represented in the Tokyo Games.

The first design created for the Tokyo Olympic Games was the official Tokyo Olympic mark. In June 1960; after considering a great number of applications, a design submitted by Yusaku Kamekura was selected and officially accepted as the symbol of the Tokyo Olympic Games, at the 8th meeting of the Organizing Committee. The Design Committee continued to function and in turn considered all aspects of designing including those for the printed matter, admission tickets, posters and medals.

The policy to which the Committee adhered was to as far as possible:—

- Use consistently the Tokyo Olympic mark
- Stress the five colours of the Olympic mark
- Coordinate all forms of printing and presentation

As the construction of sports facilities progressed and as the time approached for the choosing of the varied uniforms to be used during the Games, a re-appraisal of all aspects of designing was undertaken. This included designs and systems of signs, decorations and other details at the sites and surrounding environs.

Badges

—Olympiad mark badges

Tokyo Olympic badges were designed after considering those used during the XVII Olympiad in Rome and other Sports meetings. Badges were designed to be gold-plated and were unified into a single form. The badges for the officials, sports officials, sports teams, Organizing Committee, Press, invited guests etc., were divided into eight different types of "cloisonne colour" (a baked porcelain finish on metal) and 24 separate identifying classifications were added according to the category involved. These were further distinguished by distinctive ribbons in bright colours both plain and in combination. Additional and appropriate badge markings were designed for His Majesty the Emperor, mem-

bers of the Imperial Family, The Prime Minister, President of the IOC, member of the IOC, Secretary-General of NOC and of ISF, members of NOC and chiefs of mission.

The quantity of the badges to be cast was, in the first instance, estimated from the number of entries of the various sports events. Since there was sufficient time before the opening day of the Games, additional orders were placed as revisions to the original estimate become necessary.

—Commemorative medal

The Organizing Committee provided participation badges for the support staff, e.g. interpreters and for ground-helpers who were attached from the supporting Governmental Agencies such as the Self Defense Force, the Police Force, the Fire Defense Board, and various universities and civil organizations. These badges were somewhat smaller in size than the main Olympic badge, but conformed generally to the same design.

—Olympiad mark and badge

As a commemorative badge for distribution to the general cooperators during the Games of the XVIII Olympiad Tokyo, a badge in the form of a facsimile of the Tokyo Olympic mark was made and distributed.

This badge was not an official identification and was used from 1960 not only in Japan but also overseas, and in fact contributed materially to the excellent public relations of the Tokyo Olympic Games.

World Youth Camp

As a correlated function to the Tokyo Games, a World Youth Camp was staged in Tokyo. The Organizing Committee cooperated actively in its preparation and administration.

The Camp was organized by the Tokyo Olympics World Youth Camp Organizing Committee which was a foundational juridical person. This Organizing Committee consisted of 15 members including the representatives of the Tokyo Olympic Organizing Committee, the Japan Athletics Association, the National and Tokyo Metropolitan Governments, as well as various Youth Organizations in Japan. There was an Executive Committee and four separate departments.

The Village was open for 20 days from 6th October to 25th October 1964.

The Camp site selected was at the National Uni-

versity of Arts and Sciences in Tokyo, (Setagaya Branch Facilities).

The major functions of this Youth Camp were:—

- Parades
- Eve celebration
- Camp fires
- Entertainment by National customs of each country
- Seeing of certain events of the Olympic Games.
- Visiting industrial and cultural establishments in Tokyo
- Sight-seeing and short distance hiking trips

Admission tickets to the opening and closing ceremonies of the Games were allocated from the Tokyo Olympic Organizing Committee and donated by the sponsor to all the participants.

The costs of extending and remodelling the Camp facilities was met by the Japanese Government, and the necessary expenses for preparation and administration were covered from grants by the Japanese Government and Tokyo Metropolitan Government, and by other contributions. Each participant bore his own travelling expenses (foreign and domestic), the food costs during his stay (within \$3 a day) and certain other minor payments.

The age qualification of the participating youth, boy or girl, was stipulated at being from 15 to 25 years of age. The participating countries were 28, and the participants numbered 1,018.

Life Insurance for the Participating Teams in the Tokyo Games

At the Games of the XVII Olympiad in Rome participating teams were for the first time covered by life insurance during the Games. In the Games of the XVIII Olympiad Tokyo, life insurance was produced for the participating teams by arrangement with the Japanese Life Insurance Association, a coordinating body of all the life insurance companies, and the final policy accepted was in fact covered by some 20 of the Japanese Insurance Companies.

This insurance contract was made on the following terms:—

(1) The policy holder was the President of the Organizing Committee (foundational juridical person).

(2) The insured party was the participating teams sent by the National Olympic Committees of each country.

(3) The period of insurance coverage was, in case of personnel from overseas, from the time when each person arrived at the port or the air port in Japan until their actual departure, but within the period of Olympic Village from its opening day (15th September 1964) (except the period when the insured was out of the area and control of the



The World Youth Camp was also included in the duties

Organizing Committee).

The maximum insurance coverage was one million yen per person (US\$2,777) payable in Japanese yen, and the total insured amount was ¥8 billion (US\$22,222,222). The insurance premium actually paid was ¥1,658,800 (US\$4,608). That in fact no claims were required to be made under this policy was a matter of great relief, thanks to the careful pre-planning of all aspects of the Games and safety factors involved, and to the whole-hearted cooperations of the many people and participants concerned from all countries.

PERSONNEL

Organization of the Secretariat for the Tokyo Olympic Games and Placement of Personnel

On the initial formation of the Organizing Committee on 30th September 1959, Mr. Juichi Tsushima as President entrusted the post of Secretary-General to Mr. Masaji Tabata, and until September 1962 the secretariat took shape under this direction. In the early stages of preparations, which work included the initial drawing up of the necessary rules and regulations by which the Organizing Committee was to function, the staff was made up of eleven members from the Japan Amateur Sports Association, the Ministry of Education, the Prime Minister's Office and the Tokyo Metropolitan Government Office. No personnel at that stage, were employed on a full-time basis.

On 19th October 1959, the Secretariat was officially established with a staff of seven full-time members. It was obvious that a considerable number of persons would be required to efficiently handle the numerous requirements, such as the preparation of the Games sites, Olympic Villages and Press Centres all of which were quite widely separated, the drafting of plans for the transportation of athletes and officials, etc. From 1960 until the middle of 1962 several personnel were in fact employed to handle the more urgent administrative details of establishing basic policies for the management of the Olympic Games. On the basis of studies made by the Organizing Committee, an organizational plan and some estimates of staff requirements for the Games were determined. According to these early studies it became apparent that a total complement of some 500 full-time staff members would be required by the time the actual Games would take place.

Recruitment and Discharge of Staff

On 2nd November 1962, Mr. Shigeru Yosano was appointed as the new Secretary-General. Mr. Daigoro Yasukawa assumed the office of President on 7th February 1963, and from those dates onwards the preparations for and the management

of the Games were consummated under their leadership.

From the latter part of 1962 the preparations had reached a stage which dictated the urgency of employing a large number of personnel to handle the many problems of Games organization. As had been envisaged, the obtaining of suitable personnel from the general public presented a number of difficulties, more particularly attributable to the temporary nature of the organizing committee's term of employment offers and the technical qualifications which the work would demand. Most careful consideration had to be given to the ability of any personnel so engaged to obtain suitable employment after their term of employment with this organizing committee had terminated. This problem was successfully met however, by arranging for the temporary assignment of competent personnel from the offices of large companies, the Tokyo Metropolitan Government offices, and other local body organizations, banks and other local private enterprises. To implement these decisions, appropriate legislation was enacted, in particular the "Special personnel provision pertaining to the preparation and other activities concerning the Tokyo Olympic Games" which came into force on 1st July 1961. The organizing committee obtained some 475 persons from Government offices, the Tokyo Metropolitan Government office, and private organizations, and the success of this arrangement was in no little way due to the willing cooperation of all those organizations concerned in making available competent staff.

Organizational groups supplying personnel as at 15 Sept. 1964

	Management	General	Total
Governmental employees	8	11	19
Tokyo Metropolitan Gov't	10	109	119
Other prefectural public organizations	1	25	26
Banks	7	49	56
Other civilian & private companies	4	35	39
Sub-total	30	229	259
Other employees	27	189	216
Total	57	418	475

Number of employees by years

	Full time employees		Total	Despatched personnel	Temporary employees	Total
	Management	General				
Nov. 1959		7	7			7
Oct. 1960	7	37	44			44
Oct. 1961	16	75	91			91
Oct. 1962	25	134	159	6	1	166
Oct. 1963	42	254	296	30	3	329
Sept. 1964	57	418	475	92	34	601

Besides these full-time staff members from other organizations, certain assistance was found to be necessary to provide sufficient clerical workers. Government offices, the Tokyo Metropolitan Office and other local public organizations and some private enterprises to this end offered the services of their staff whose status vis-a-vis their respective organizations would not be changed. (an example of this type of assistance was the personnel seconded from the Defense Agency)

The tables in this section show the number of personnel by year, by organizations from which they were detached, and the Division to which they were attached.

Posting of Personnel during the Tokyo Olympic Games

To efficiently handle specific operations of the Games, it became advisable to open detached offices at each Games site, at Haneda Airport, the Olympic Villages and Press Centre. The number of personnel allocated to each Director of the various offices can be seen from table in this section.

Number of Personnel

Those employed in duties connected with the Olympic Games were categorized under the following headings according to their employment status, services rendered and working conditions:

- (1) Secretariat Staff
- (2) Detached Personnel
- (3) Personnel of Prefectural and Municipal Offices whose services were offered only during the Olympic Games to assist in specific assignments.
- (4) Temporary Assistants
- (5) Supporting Staff of the National Self Defense Forces.

Competent persons were employed temporarily from the general public and from students of physical education colleges and universities. The students, with their natural interest in sport, made a most valuable contribution to the successful outcome of the Games organization.

Besides these persons who were directly engaged in operational duties for the Games, there were a great many others who rendered services indirectly. Included in this heading were the field officials whose specific duties were entrusted under the joint arrangement of Sports Federation and the Organizing Committee, Boy Scouts and members of other Youth Organizations who assisted in such services as flag hoisting during a short period in the morning and in the evening, personnel of Police and Fire-stations who though they were not under the direct supervision of the Committee, performed most valu-

able help and worked on close contact with the Organizing Committee. Their function formed an important part of the overall organization.

- A. Personnel serving the Secretariat Headquarters and other Offices (a detailed classification is given in the attached table) 17,979
- B. Field officials and assistants 6,884

Note: Field officials and their assistants were entrusted with specific duties under the joint names of various Sports organizations and the Organizing Committee.

Note: Guidance of spectators and maintenance of order in and around the sites were under the jurisdiction of the Fire Defense Agency (supervisory) as well as the Organizing Committee (direct). Maintenance of order along the roads used for Marathon and other road races was the responsibility of the Police concerned (policing) as well as of the Organizing Committee itself (direct).

The services of these officials contributed greatly to the success of the Games and they performed their duties only after extensive study and training in methods to ensure the prevention of confusion and accidents during the period of the Games.

- D. Personnel engaged in hoisting flags . . . 14,400

Note: This task entailed demanding physical work to daily raise and lower the very large numbers of flags of the participating nations at the various sites.

Boy Scouts and members of Youth Sports Organizations performed these duties adequately. These Olympic Games incidently resulted in a unique opportunity for the younger generation to appreciate the dignity of National Flags and the International Spirit of the Olympics. The deep impressions gained at these Games is likely to remain long in the hearts of the youths who participated.

Discharge of Secretariat Personnel

With the close of the Olympic Games, supporting personnel of the National Defense Force and cooperating personnel of the Fire Defense Agency and the National Police Board returned to their respective organizations. The Games field officials, flag hoisting personnel and temporary employees were automatically released as their specific tasks were eliminated after the close of the Games. By the end of October, 1964 most of the part-time assistants and detached staff had been relieved of their assignments.

It had been arranged that most of the general staff of the Organizing Committee were to be retired by the end of November, since their term of employment would expire with the close of the Games. Those excepted were the few who were responsible for the disposal of the properties, pre-

paration of this report, etc. Priority was given to those who were detached from the Governmental offices, Tokyo Metropolitan Office, Banks, etc. and who would not be faced with the necessity of looking for employment after discharge. An "Employment Assisting Committee" was established in April, 1964 within the Organizing Committee to assist in finding alternate employment without delay, and some 150 persons were placed from this service. These precautions in employment was rewarded by the fact that no serious employment problems developed and the retirement was effected smoothly with the cooperation of all concerned. The following table

shows the retirement time of Secretariat personnel until June, 1965.

Number of Personnel	As of Date
475	September 15, 1964
474	October 1, "
469	November 1, "
278	December 1, "
204	January 1, 1965
178	February 1, "
159	March 1, "
55	April 1, "
52	May 1, "
52	June 1, "

Number of personnel assigned to the headquarters and each venue administration offices at the time of the Games

Offices	Categorized	Secretariat Staff	Detached Personnel	Cooperating Staff	Temporary Assistants	Supporting Staff	Total
Secretariat Headquarters		224	87		1,514	720	2,545
Transportation Head Office		25	7	24	92	930	1,078
Press Head Office		45	5		179		229
National Stadium		15	20	572	1,009	907	2,523
Prince Chichibu Memorial Football Field		4	6	69	135		214
Meiji Jingu Baseball Stadium		4		148	191		343
Metropolitan Gymnasium		9	3	63	112		187
Tokyo Metropolitan-Indoor Swimming Pool		4		27	61		92
National Gymnasium		13	16	98	203		330
National Gymnasium Annex		4	9	34	73		120
Shibuya Public Hall		6	3	30	112		151
Komazawa Sports Park Administration Office		3	33	89	119		244
Komazawa Gymnasium		5	2	36	64		107
Komazawa Stadium		4	14	105	280		403
Komazawa Hockey Ground		4	8	65	151		228
Komazawa Volley-ball Court		2	4	38	89		133
Korakuen Ice Palace		5	9	29	56		99
Waseda Memorial Hall		7	5	40	91		143
Nippon Budokan Hall		6	6	90	211		313
Equestrian Park		5	1	30	103		139
Hachioji Velodrome		1	11	38	186	146	385
Omiya Football Field		1	11	66	178		256
Toda Rowing Course		2	14	49	180	85	330
Asaka Shooting Range		3	8	31	87	770	899
Tokorozawa Clay Shooting Range		1	12	19	62	120	214
Lake Sagami		2	7	26	88	143	266
Enoshima Yacht Harbour		2	9	32	79	2,562	2,684
Yokohama Cultural Gymnasium		1	11	94	36		142
Mitsuzawa Football Field		1	8	140	50		199
Karuizawa Equestrian Ground		1	9	24	82	358	474
Kemigawa Grounds		2	6	23	59	236	326
Haneda Air Port Reception Office		7	2	25	36		70
Information Centre		4	6	12	24		46
Yoyogi Olympic Village		74	15	2	931	565	1,587
Hachioji Village		7	8	21	117		153
Sagami Lake Village		2	13	18	103		136
Oiso Village		2	11	19	91		123
Karuizawa Village		2	17	2	47		68
Grand Total		509	416	2,228	7,281	7,545	17,979

Note: (1) 720 persons from Supporting Staff who were assigned to Secretariat headquarters as listed in the first column were Administrative type personnel.

(2) There are some difference in actual numbers of personnel at any given time, and the figures in above table which were those as at 18th October, 1964.

Number of personnel assigned to each Section and Division of the Secretariat Headquarters

(As at 15th September 1964)

Personnel Sections	Secretariat Staff					Part-time Assistants	Seconded Personnel	Total
	Management	General Staff	Technical Personnel	Others	Total			
Secretary-General, Vice Secretary-General Assistant Secretary	9				9			9
Coordinating Division	1	4			5		4	9
Administration Division								
General Affairs	3	24	24	13	64	4		68
Personnel	2	8			10	1		11
Foreign Affairs Division								
Foreign Affairs	1	24	1		26		1	27
Protocol	1	8			9		2	11
Interpreters	1	5			6	1		7
Finance Division								
Accounting	3	11	1		15		1	16
Contract	1	13			14			14
Disbursement Division								
Cash Disbursements	2	6	1		9			9
Property Control	2	9			11		1	12
Stadium and Ticket Division								
Stadium	1	14	1		16		21	37
Ticket	2	19			21		3	24
Medical & Sanitary	1	6			7		6	13
Security and Traffic Division								
Security	3	5	1		9		11	20
Traffic	1	4			5		1	6
Transportation and Communication Division								
Transportation	2	16	2		20	5	11	36
Communication	1	5	3		9			9
Facilities Division								
Planning	2	7	2		11			11
Installations	2	8	22		32		6	38
Press and Public Information Division								
Press	2	13			15	17	6	36
Public Relations	1	17	3		21			21
Olympic Film	(1)	4			4			4
Foreign Press Division	2	2	1		5		2	7
Sport Technique Division								
Sport First	2	14	1		44		7	51
Sport Second	1	7			8	1		9
Art Exhibition	1	4			5	1		6
Ceremony	1	11			12	2		14
Olympic Village Division								
Village Administration	2	12	1		15		9	24
Operation	2	17			19	2		21
Supply	1	6			7			7
Detached Village	1	11			12			12
Total	50	341	64	13	475	34	92	601

Note: Figures in the parenthesis indicate persons serving in dual positions.

DOCUMENTARY FILM PRODUCTION

The Organizing Committee early turned its attention to preparations for the official documentary film of the Tokyo Olympic Games, realizing that considerable interest was already focussed on productions of Japan's cinema industry, and for this reason more than the usual interest was likely to be stimulated in an Olympic Film made in this country.

As early as June 1960, before the opening of the Rome Olympics, Mr. Masaji Tabata, the then Secretary General, decided after consultation that it would be advisable for a Japanese Director to make a study tour in Rome preparatory to producing a documentary film of the Tokyo Olympics. Mr. Akira Kurosawa was selected as the man most qualified and he was despatched to Rome accompanied by Mr. Matsue, as assistant director.

In the summer of 1961, an estimate for the production of the Tokyo Olympic documentary film was calculated at 550.0 million yen (US\$1,527,778) by Mr. Kurosawa and his staff.

In early 1962, a two-man survey team from the Organizing Committee was sent to Rome to make a study of financial matters relating to the Rome Olympic Games. In its report it was stated that receipts from the distribution of the Rome Olympic film amounted only to 200.0 million yen (US\$555,556) or less, which amount was below the figure anticipated.

It appeared then, especially in view of the wide television coverage anticipated, that large receipts should not be expected from the showing of an Olympic Film, and accordingly it was suggested, that the estimates of expenditure should perhaps be revised. Director Kurosawa recommended that more than one Director be engaged to whom he would be prepared to offer his advice. In the summer of 1962, following the views expressed by Director Kurosawa, the Organizing Committee formulated a reduced budget in an amount of 290.0 million yen (US\$805,556) for the film production, and estimated the income from this at 250.0 million yen (US\$694,444). This plan was submitted to the authorities and subsequent approval was obtained for an even budget amount of 250.0 million yen (US\$694,444) for both income and expenditure.

In the spring of 1963, a proposal was made by the News Reel Companies Association for theatre use for the participation in the production of the documentary film of the Tokyo Games, and Messrs. Toho Co., Ltd., who had been suggested as the

company who would be entrusted with the production, expressed a desire not to be solely responsible for the production. Seven firms engaged in the News Film Production, then established a juridical person - the "Tokyo Olympic Film Association", and this association was commissioned by the Organizing Committee to film the Tokyo Games.

After considerable deliberation, Mr. Kon Ichikawa of Daiei Motion Picture Co., Ltd. was in January 1964 appointed as Director General for the film production.

Tokyo International Sports Week

The Tokyo International Sports which was held in October 1963 offered an excellent opportunity for a test film embracing the twenty different sports of the Olympic Games. This was made in EK colour, in over 10,000 meters, and had a running time of about three hours. Through this undertaking, valuable experience was obtained relating to the technical aspects of equipment, personnel and facilities. From this test film two important problems became apparent: viz. the lighting for the indoor sports events, and the shooting position in infields, arena and ringside. It was believed that the question of illumination could be worked out locally, but the other issue was one within the jurisdiction of each International Olympic Federation.

Increase in Lighting Installation

The conditions for colour wide screen shooting for gymnastics, volley-ball and fencing were found to be far from ideal, and consideration was given to abandoning the attempt to film these in colour. With an additional appropriation of 44.0 million yen (US\$122,222), however, the installation of additional lighting was arranged as listed in the table below.

Games venue	Intensity (lux)	Lighting system
Tokyo Metropolitan Gymnasium	1,000—1,500	High-spot 200 pieces
Komazawa Volley-Ball Court	800—1,200	Sky-light
Yokohama Cultural Gymnasium	400— 900	Sky-light Mercury lamp

In addition, lights of a minimum 900 lux were installed in other indoor venues for swimming, judo and wrestling, thus enabling pictures of beauty to be obtained without the necessity for additional treatment in processing.

Camera Positions for Indoor Events

Camera positions on the stands at all the sites had been assured by the assistance of the Ticket Division which secured seats for the shooting crew in advance of the sale of tickets to the public. Difficulties were encountered in adequate camera positions from the infields and also from the dugout in the athletic field, and in ideal methods of filming the Cycling road race and Marathon race from mobile cars. After several consultations with the International Amateur Athletic Federation, one camera tower was allowed in the infield and three cameramen and a special car were permitted to follow the Marathon race. For the Rowing and Cycling road races, appropriate arrangements were made after consulting with officials of the International Sports Federations concerned.

Scenario

Director Ichikawa after accepting the post of Director General for the production of Olympic film, commenced the script writing. The scenario writers numbered four in all and included the Director-General himself, Natsuto Wada, Yoshio Shirasaka, and Shuntaro Tanigawa. Detailed filming plans were then worked out on the basis of the script.

To further prepare themselves in all matters of technical and practical details of filming athletes in motion, the photographic staff attended local National Sports meets. These preliminary practice filming arrangements helped materially in adjusting the individual photographic crew into a composite team.

Director Ichikawa and his staff made inspections of the National Stadium where the opening and closing ceremonies and athletics were scheduled to take place, and acquainted themselves with the interiors of the sites for swimming, basket-ball and volley-ball during the construction of these facilities, making studies on camera positions, the number and types of cameras and lenses required and other considerations of a technical nature which were likely to confront them in actual filming. These initial arrangements were of necessity subjected to a number of revisions as the plans and construction work progressed. It was however, this detailed and continuous planning which enabled the cameraman to fully interpret the concept of theme in the mind of the Director-General of the film production.

Olympic Documentary Film Committee

The Olympic Documentary Film Committee was formed on 26th May 1964 as a consultative organ

to the Secretary-General of the Organizing Committee. Its purpose was to deliberate on matters relating to the basic policy for the production of the Olympic documentary film, to arrange the budget for the production, provide for film distribution, etc.

Public Subscription for the Title of the Film

In view of the great interest and expectations of the nation in the production of this film, it was proposed that the public select a suitable title. Over 80,000 names had been submitted by the public and the Documentary Film Committee, after thorough deliberation, selected the name "Tokyo Olympiad".

Stereophonic Sound Adopted

The Organizing Committee in studying the submitted scenario decided that the beauty of colour and design in this production should be complemented by a stereophonic sound track on the final print. For filming of the closing ceremony as well as the events and competitions held at night, it was decided to adopt the recently developed Techniscope system from Italy. An additional appropriation was provided to obtain the necessary material for recording and filming to incorporate these additional requirements.

Equipment

The equipment required to film and sound record all 20 sports and the over 160 competitive events to be taken from multiple angles, reached a formidable volume. Although the full cooperation could be anticipated from the cinema production industry, it was acknowledged that their own film production arrangements of these various commercial companies made the actual practical assistance in making equipment available limited. With this realization, the Organizing Committee made an appropriation of about 83.0 million yen (US\$230,556) to purchase equipment which included the following:—

Cameras and Film Equipment	
a. Arriflex 35IIBV Cameras	20 units
b. Ecrafil GV35 High Speed Cameras	2 "
c. Cameralex 35 Cameras	5 "
d. 40mm-1600mm Lens	39 pes.
Sound Recording Equipment	
a. Portable Tape-Recorders (including Stereo)	29 units
b. Microphones	65 "
c. Wireless Receiving Sets	3 sets
d. Microphones Cable	3,500 metres

In addition to the equipment purchased directly by the Organizing Committee, the following equipment was used:—

Cameras

Arriflex 35 Cameras	42 units
Eye-mo Cameras	27 "
Mitchell Cameras (including 2 Highspeed Cameras)	6 "
Ecrail 35 Cameras	3 "
Cameralex 35 Cameras (Highspeed Cameras)	5 "

Total: 83 units

Lenses

Lens for Eye-mo Cameras

35mm	1
50mm	34
75mm	2
85mm	24
100mm	9
105mm	1

Arriflex (for Mitchell, Ecrail Camera)

40mm	3
50mm	12
75mm	5
85mm	4
100mm	7
135mm	1
200mm	8
200mm zoom	7
210mm	1
300mm	1
400mm	3
400mm zoom	9
420mm	2
500mm zoom	9
600mm	9
800mm	3
1000mm	2
1200mm	3
1600mm	2
2000mm	1

Total: 92

In all a total of: 163

Olympic Torch Relay

Olympic torch relay enroute from Greece A most important opening phase in the Olympic film was regarded as the filming of the ceremony at ancient Olympia in Greece and then following the Olympic torch through the countries of south-east Asia which it passed.

Accordingly a four-man photographic team left for Greece on 1st August 1964 in advance of the chartered JAL aircraft which would carry the Olympic torch. In Greece, with the kind coopera-



Kon Ichikawa directing the shooting of the Documentary Film



A snap taken at Olympia, Greece for the Torch Relay



Cameramen stationed at the National stadium for shooting athletic events

tion of the National Olympic Committee of Greece and the assistance of the Japanese Embassies in Greece and the other countries through which the relay passed, adequate arrangements for filming were organized and the crew returned to Tokyo on 10th September.

The equipment the crew carried with them on that occasion included the following:—

Arriflex 35IIBV Camera		1
Lenses for the above	40mm	1
	50mm	1
	75mm	1
	100mm	1
	200mm	1
	600mm	1
	500mm zoom	1
400 F Magazines		2
Tripods (large and small)		1 set
Bell & Howell Imo Camera		1
Lens for the above	50mm	1
Lens	85mm	1
Eastman Colour Film		8000 ft

Olympic torch relay in Japan The film crew covered the four Olympic torch relay routes which spanned the entire country of Japan, to film the required footage in terms of the film script. These shots included:—

Hiroshima (Atomic Dome, Peace Park)
 Osaka (through the city)
 Kyoto (glimpses of old Japan)
 Uwajima (through rural area)
 Tottori (through seashore and sand dunes)
 Oyashirazu (through fishing villages)
 Mt. Fuji
 Tokyo

In completing these filmings and by courtesy of the Self Defense Force, a helicopter H-19 was despatched from Tokyo to enable the crew to film the torch relay in Hiroshima and Uwajima from the air.

List of Film Footage Taken

The actual number of crew members engaged in the work with the documentary film of the Games, increased to several hundreds as the opening of the Games approached. The shooting crew moved its headquarters to the Akasaka Detached Palace where the Transportation Headquarters was located.

The films shot include the following:— changing face of Tokyo; Olympic Torch Relay from Greece to Tokyo; participants and officials arriving in Tokyo from all over the world; the Opening Ceremony on 10th October; and all events during the Games and culminating with the Closing Ceremony on 24th October. The entire footage of films which

reached 322,933 feet or 97,858 meters was made up as follows:—

Subjects	Footage filmed	Footage used for Japanese edition
	ft.	ft.
Tokyo	10,277	214
Haneda, Yokohama (participants arriving)	9,910	(Included in Olympic torch)
Journey of torch, abroad	7,100	221
Journey of torch at home	8,375	499
Opening ceremony	23,920	1,460
Athletics	57,923	4,739
Press centre	1,260	(Included in athletics)
Gymnastics	19,320	586
Episodes of general interest	14,635	842
Swimming & Diving	14,080	650
Weight-Lifting	5,760	299
Wrestling	7,190	151
Boxing	9,320	178
Fencing	3,570	101
Judo	12,640	337
Rifle shooting	5,160	259
Cycling	4,850	395
Football	6,500	139
Equestrian sports	2,480	
Basket-Ball	4,180	
Water-Polo	200	
Hockey	5,720	
Volley-Ball	20,810	600
Canoeing	3,480	55
Rowing	2,350	44
Yachting	2,440	92
Modern pentathlon (cross country)	100	248
Marathon	35,942	2,260
Closing ceremony	14,140	439
Others, Imperial Family	785	
Trailer	440	
For tests	8,065	

Shooting Staff

The actual shooting was completed with the Closing Ceremony on 24th October. The following list shows the actual number of staff directly involved with the filming. The close liaison maintained with the Film Recording Section and the Press Division of the Organizing Committee, and the diligent efforts of all concerned made the successful filming of the "Tokyo Olympiad" a reality.

Producer	1
Assistant Producer	3
Director-General	1
Technical Director	1
Sound Recording Director	1

Music Director	1
Directors Division (Assistant Directors)	28
Shooting Division (Assistant Cameramen included)	93
Sound Recording Division	27
Lighting Division	39
Promotion Division	14
Machine & Film in Charge	2
Machinery Division	8
Chauffeurs	41
Office Clerks	5
Total:	265

In addition to these persons, a number of students from the Cinema Course of the School of Arts, Nippon University cooperated directly and were assigned as trainees to the Director's, Shooting, Sound Recording and Lighting Divisions.

Editing

During the Games themselves, the developing of films was done in the basement of Akasaka Detached Palace and these were screened in a preview room each evening and viewed by the Director-General and others. Plans for the following day were then discussed and instructions issued accordingly.

Actual editing was commenced early in November 1964 when an editorial room with a preview room was established at a different location.

Sixteen members comprising Director-General Ichikawa, members of the Directors Division and Editing Division were divided into eight groups. This staff undertook the demanding task of reducing the 300,000 feet of film, first 100,000 feet and then to the 30,000 feet the length of the film before final editing.

The screening of the entire footage would take some 72 hours. To run the entire sound recorded tape would have consumed over 240 hours. Actually it took two months to reduce this film to 30,000 feet, and this was almost twice the length of the 16,000 feet in the final plan.

Editing staff was divided into groups of sports and events and commenced their work to select sections for the pre-arranged script.

The first 18,000 feet was completed on 20th January 1965. This was followed by deliberations between the Director-General and the Secretariat of the Organizing Committee, and the final editing of the film was carried out. The dubbing of music by the Yomiuri Nippon Symphony Orchestra at the Tokyo Cultural Hall was completed on 28th February 1965, and thus the documentary film of "Tokyo Olympiad" was brought to completion. The first special screening of this film was made on 10th March 1965 in the gracious presence of their

Majesties the Emperor and Empress of Japan, and an impressive gathering of guests. This was later followed by a screening for some 9,000 persons including those who were connected with the Olympic Games. On both of these occasions this film was most favourably accepted.

Several minor alterations to the Japanese edition were considered necessary and the Organizing Committee accordingly requested the Tokyo Olympic Film Association through its Director-General to both add certain super-impositions and make a number of revisions to the scenes included.

With these revisions effected on 15th March 1965 the film was distributed throughout the country by 20th March to the 260 Toho Motion Picture Chain Theatres for showing. The final edition was of 15,226 feet and required 2 hours and 50 minutes to screen.

International Edition

The International edition in English with substantially the same revisions as the Japanese edition was completed in early April 1965. The footage was 11,634 feet, requiring 2 hours and 10 minutes for screening.

Distribution It was hoped that the distribution system chosen for this film would be one which gave optimum coverage to allow as many persons as possible, both at home and abroad, to see the pictorial recording of these, the first Olympic Games ever to be held on Asian soil.

In early September 1963, a request for a distribution plan was made to the Japan Motion Picture Producers' Federation (consisting of five producers: Toho Co., Ltd., Toei Company, Ltd., Nikkatsu Corporation, Daiei Motion Picture Co., Ltd. and Shochiku Co., Ltd.). This Federation was requested to make recommendations concerning the film distribution, its methods, markets, estimates on income and related matters. Subsequently, on 20th August 1964, the Federation recommended that the Toho Co., Ltd. be designated the task of this film's distribution both at home and abroad, with the conditions hereunder mentioned.

- For distribution at home
65 per cent of the net income after all expenses deducted should be paid to the Organizing Committee.
- For distribution abroad
85 per cent of the net income after all expenses deducted would be paid to the Organizing Committee.
- A minimum sum of ¥125.0 million (US\$347,222) should be guaranteed to the Organizing Committee.
- Upon signing of a contract an advance pay-

ment of ¥30.0 million (US\$83,333) should be made to the Organizing Committee.

The Organizing Committee after deliberating on the conditions presented, made certain counter-suggestions on the argument that the minimum guarantee was too small. The matter, however, was settled with the Toho Co., Ltd. agreeing in writing to exert their utmost efforts to achieve the target amount of ¥250.0 million (US\$694,444). The contract was concluded on 8th October 1964 between the Organizing Committee and Toho Co., Ltd. and witnessed by the President of the Movie Producers' Federation.

Distribution in Japan

The successful Tokyo Olympic Games had left deep impressions all over the world, and the expectations for the Olympic film were regarded as good. For publicity purposes a special 80 feet of film sufficient about one minute, and a trailer of about 250 feet for about 3 minutes screening had been shown in the movie theatres throughout the country. The reaction was quite encouraging. The public showing was commenced on 20th March 1965 through the chain theatres of Toho Co., Ltd. and this was greeted most enthusiastically and with great success.

For Educational Institutions

Special emphasis was given to having as many as possible of the younger generation view this film to impress them with the Olympic spirit and the promotion of understanding of the Olympic movement. With this in view the Organizing Committee requested the Ministry of Education to cooperate by conveying the intent of the Committee to all Education Boards in cities and prefectures over the entire country. In complying with this request a notice was issued by the Director of Bureau of

Physical Culture of Ministry of Education.

Special reduced admission fees for school children were agreed as follows:—

Elementary and Middle School Pupils:

40 yen (US\$0.11)

High School Students:

80 yen (US\$0.22)

Statistical records as at the end of Sept. 1965 for the Olympic film showing in Japan appeared as follows:—

(from 20 Mar. to 20 Sept.)

	No. of theatres	Admissions	Paid admissions	Net share to OOC
General showings	2,229	7,742,433	1,898,726,934	1,071,408,407
Special showings	2,210	11,859,598	572,646,471	140,073,052

The earnings from the film showing in Japan from the date of its public screening for two months reached a sum exceeding the entire cost which the Organizing Committee had paid to produce this film.

International Distribution

Outside Japan, Bermuda made the initial contract on 20th October 1964. As at 6th May 1965, 24 contracts for export for 51 countries had been concluded, and including those at that time under negotiation with firms in U.S.A. and Canada, the income amounted to \$356,000 (¥128,160,000).

Upon receipt of an invitation from the Cannes International Film Festival authorities extended through Toho Co., Ltd. to participate the Tokyo Olympiad in the Festival, the Organizing Committee entered its Japanese edition, slightly reduced in footage with a superimposition in French. Director Ichikawa was despatched to attend the Festival. This film has been awarded a number of prizes including:—

- Cannes Festival:

The prize of the international union of film critics

Special prize as the best film for youth

- Cork (Ireland) Festival:

Waterford Glass Award for the best film

- At the International Film Festival in July 1965 in Moscow, the film was submitted by the Committee and received the prize of the Sports Union.

- At the VIII Reseña municipal de los festivales cinematograficos held at Mexico in 1965, the film was awarded the Cabeza de Palenque.

- British Film Academy Awards:—

United Nations Award 1966

Robert Flaherty (documentary) Award 1966

A scene of charging batteries which were motive power for shooting the film

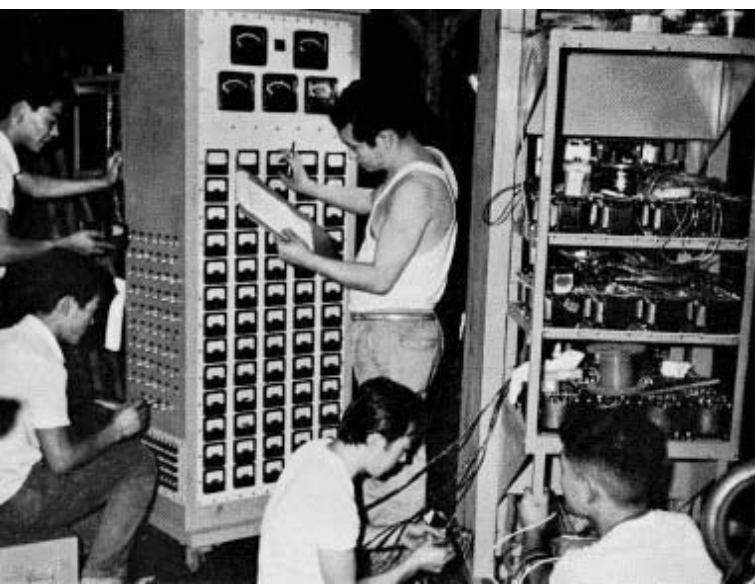

MEDICAL AND SANITATION SERVICES

Summary of Activities

Medical Services Special clinical and medical facilities were established for athletes, officials and spectators of the Olympic Games at the Olympic Villages, Games sites and the training venues in order to treat patients in the event of their illness or injury.

Sanitation Services and Health Precaution To ensure that no infectious disease appeared among the Olympic participants, great care was exercised in sanitation at all the Games and Village facilities, including restaurants, shops and stands, barber and hairdressing shops, recreation halls, theaters, etc., and these functions were severally under the control of the authorities concerned. Exhaustive instructions on food handling; medical examinations of the workers and inoculations were disseminated.

Cooperating Establishments Government and Public university hospitals, the Defense Agency, the Japan Red Cross, etc., pledged their support and cooperation from outside the Olympic Organizing Committee in the event that any emergency presented itself. Matters of food sanitation, environmental sanitation and epidemic prevention were mainly conducted by the relevant Government of

Medical organizations and structures

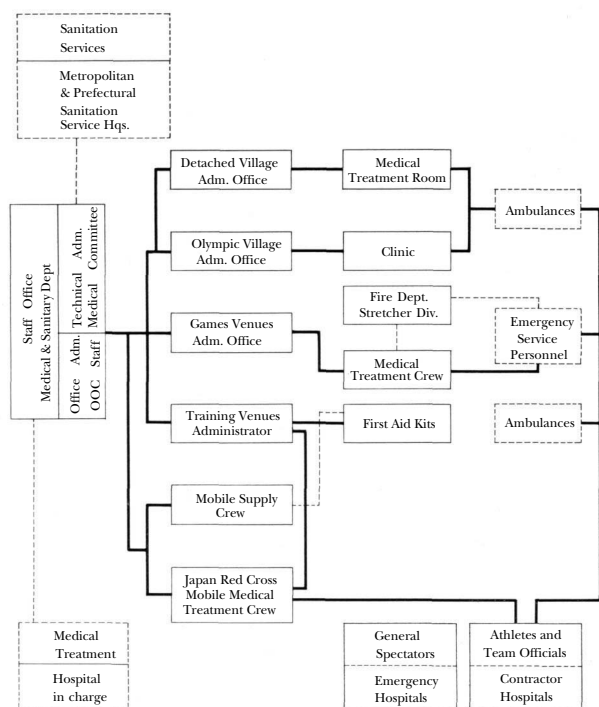

ofices involved and including the Tokyo Metropolitan Government and all local authorities concerned.

Organization of Medical and Sanitation Services

Special Committee A Medical and Hygienic Committee was set up to advise the Organizing Committee, and it was made up of members of sanitation authorities of the Ministry of Health & Welfare, administrative office of Tokyo Metropolitan Government, and others concerned including sports physicians of university hospitals. This Committee held fifteen special meetings from its creation on 28th May 1960 until 26th November 1964. Reports were presented on (1) Administration and Operation of Medical facilities in the Olympic Villages, (2) Medical Services at the Games sites and (3) Technical Services at the Games facilities.

The actual responsibility for medical and sanitation at the time of the Games itself can be seen from the chart on the following page.

Medical Services

Olympic Village at Yoyogi Yoyogi Village Clinic

Service Period: 15th September 1964—5th November 1964

Clinic Branches (Organization of the Clinic)

Hours:

08:00 hrs—21:00 hrs

Medical, Surgical & Physical Therapy Sections

08:00 hrs—17:00 hrs

Ophthalmological, Otolaryngological & Dental Sections

Services Rendered: Hospitalization, Examination, Prescription of Pharmaceutical & Therapeutic materials, Surgery and Nursing

Emergency Service After Hours: Physicians and Surgeons were on emergency service at night.

Facilities: Four-story reinforced concrete building of 1,580 sq. meters with 7 medical wards and 19 beds

Allocation of Personnel:

Medical Doctors

Director in Charge	1
Medical Section	1 (1)
Surgical Section	2 (1)
Otolaryngological Section	1
Ophthalmological Section	1
Dental Section	3

Organization of the Clinics

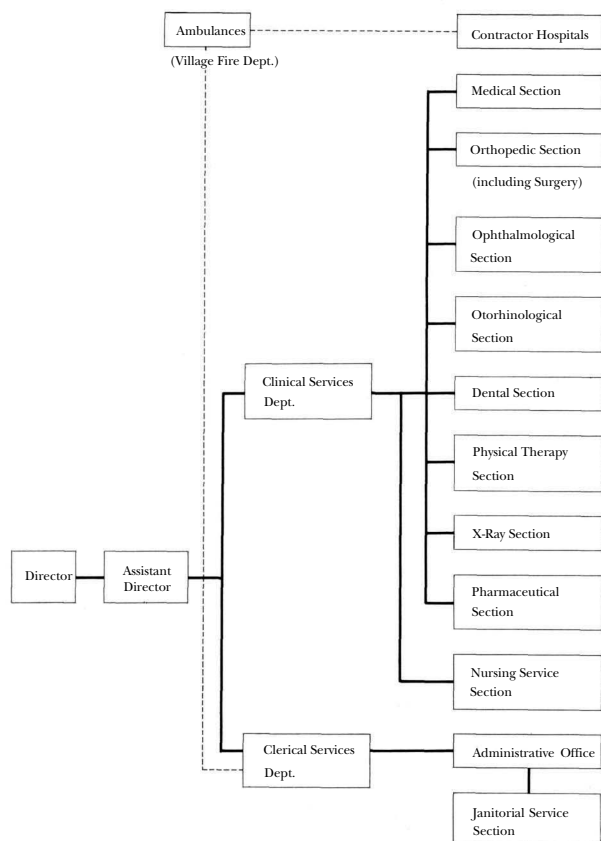

Night Duty	2
Total	13
Nurses	
Medical Section	1 (1)
Surgical Section	2 (2)
Otolaryngological Section	1
Ophthalmological Section	1
Dental Section	3
Treatment & Opr. Section	1
Ward-Daytime	3
—Evening	3
—Night	2
Night Duty	1
Total	21
Assistant Nurses	
Day Duty	2 (2)
Total	4
X-Ray Technician	
Day Duty	1 (1)
Night Duty	1
Total	3
Pharmacists	
Day Duty	1 (1)
Total	2
Masseurs	
Day Duty	8 (8)
Total	16
Clerical Personnel	
Day Duty	6 (3)
Night Duty	2
Total	11
Janitors	
Day Duty	4 (4)
Total	8

Grand Total 78
 Day Shift 72
 Night Shift 6

(Figures in parenthesis are relief personnel)

Medical Equipment and Facilities:

Office	Equipment
Medical	Electrocardiograph (1) Anthropometer (1)
Orthopedic (Surgical)	Surgical Examination Equipment
Ophthalmic	Unit (1) Precision Eyesight Measuring Apparatus (1) Cornea Microscope (1)
Otolaryngological	Unit (1)
Dental	Unit (3) Dental X-Ray Equipment (1)
Treatment and Operation	Operation Table (1) Surgical Equipment (1 Set) Aspral Lamp (1)
X-Ray	KXO-14 High Pressure X-Ray Photograph Equipment (1) Development Equipment (1)
Massage	Massage Bed (14) Ultra-Sonic, Ultra Micro-Wave, Low Frequency, Treatment Equipment (each 1) Stupe (1)
Bathing	Bathing Equipment (2)
Ward	Male Ward (5) Female Ward (2) Carriage Bed (4) Semi-Carriage Bed (4) Bed Extension (4) Bed (7) Side-Cabinet, Side-Table
Other Facilities	Pharmacy, Test Room, Pantry,

Number of inpatients at Yoyogi Olympic Village Clinic

Complaint	No. of cases
Common cold	7
Acute bronchitis	2
Acute tonsillitis	3
Acute gastroenteritis	6
Acute hepatitis	1
Migraine	1
Hypertension	1
Angina pectoris	1
Acute circulatory insufficiency	1
German measles	1
Chicken pox	1
Erythema exsudativa multiforme	1
Fatigue	2
CO-gas intoxication	1
Drunkenness	1
Head injury	2
Laceration	3
Fracture	3
Strain	2
Sprain	1
Arthritis	1
Back pain	1
Excoriation	1
Carbuncle	1
Acute epididymitis	1
Contusion of testicles	1
Urinary stone	2
Acute appendicitis	2
Phlebitis of leg	2
Total cases	53

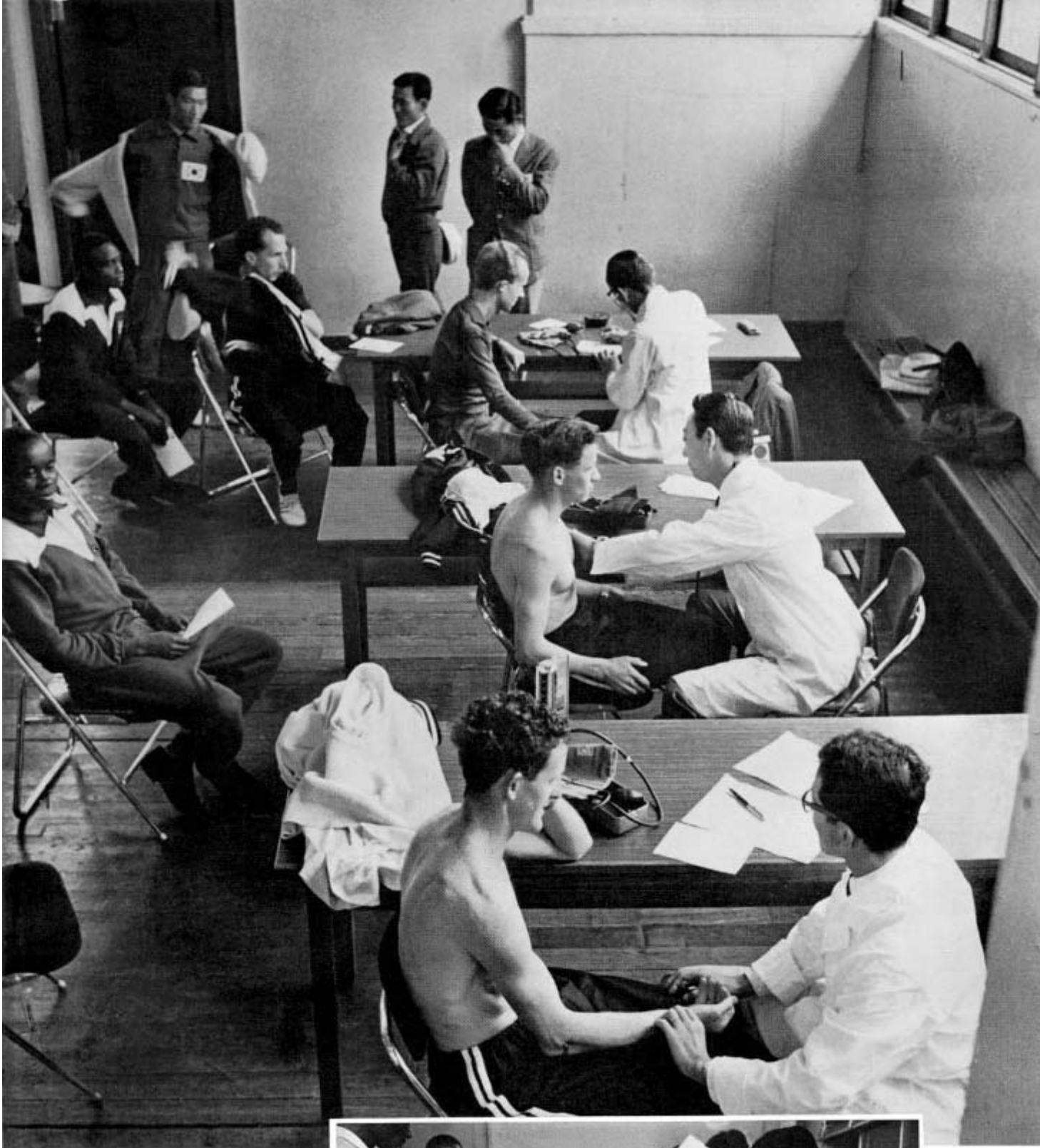

Physical examinations prior to the marathon race



Number of cases treated at Yoyogi Olympic Village Hospital (by sports)

	Surgery and Orthopaedy														
	Head injury	Fracture	Dislocation	Sprain	Contusion	Sprained finger	Laceration	Excoriation	Strain	Myalgia	Back injuries	Arthralgia	Achilles peritendonitis	Traumatic periostitis	Foot pain
Athletics	1			26	9	2	9	7	30	32	15	23	4	5	12
Rowing		1					1				3	1			
Basket-Ball			1	11	6	2	2		2	4	5	4	1	1	
Boxing		4		18	13	3	8			4	2	6			
Canoeing				1								1			
Cycling								1							
Fencing		2		2	3	2		1	6		4	1	1	1	
Football	1	3	1	18	9	1	2	4	3	3	3	2	3		1
Gymnastics		1		15	3	2	2		4	9	9	10			1
Weight-Lifting				3	2	1			3	2	8	1	1	1	
Hockey	2	5		8	19	1	12	5	5	10	8	3			1
Judo		1			3	1	1	2			1				
Wrestling			2	13	11	4	2	2	2	3	6	2			
Swimming & Diving	2	5		12	5	5	3			8	5	3	4		
Modern Pentathlon				1						1	1				
Equestrian Sports			1		1				1						
Shooting		1									1			1	
Volley-Ball		1		6	3	1	2			4		6			
Water-Polo					1		1				2	1			
Yachting							1								1
Others		4		4	3		2	2			2	2	1		
Total	6	28	5	138	91	25	48	24	56	80	75	67	15	9	16

	Ophthalmology												Periodontitis alveolaris purulenta acuta	Periodontitis apicalis purulenta acuta
	Conjunctivitis	Blepharitis	Hordeolum	Chalazion	Keratitis	Foreign body of cornea	Contusion of eyeball	Detachment of retina	Traumatic Cataract	Orbital bleeding	Others	Total		
Athletics	1		1		1						5	8	4	3
Rowing														
Basket-Ball														1
Boxing	1					1	1		1	1	1	6	1	
Canoeing														
Cycling														
Fencing			1								1	2		
Football						1						1		
Gymnastics			2									2		
Weight-Lifting														
Hockey			1		1		1					3	1	1
Judo	1									1		2		
Wrestling							1					1		
Swimming & Diving	2	1						1				4		
Modern Pentathlon														
Equestrian Sports														
Shooting	2			1							1	4		
Volley-Ball														
Water-Polo			1				2				1	4		1
Yachting														
Others	1					1					7	9	1	
Total	8	1	6	1	2	3	5	1	1	1	17	46	7	6

						Internal Medicine						Otorhinolaryngology				
Boils	Blisters and shoe sores	Athlete's foot	Other skin diseases	Others	Total	Common cold	Pharyngitis	Bronchitis	Gastroenteritis	Others	Total	Acute rhinitis	Otitis externa od media	Ceruminous plug	Others	Total
2	7	2	3	16	203	24	17	7	5	34	87	2		2	6	10
				2	10	4	2	1	3	2	12				2	2
				1	40		1	1	1	1	3				1	1
1				1	60	8	4	2	2	6	22	1	1		2	4
				2	2											
				4	4											
1				2	27	3	2		1	4	10	1			1	2
	1	1		2	56	8				4	14	1		1	2	4
				3	60	5	3	2		7	17	1			5	6
	1		2	7	32		2		1	8	11					
1	1	1		3	85	5				6	11				2	2
1	1			1	12	1	2		3	5	11				5	5
1	1		1	5	54	2	2		1	12	17		2		6	8
1			2	8	64	12	12	1	1	9	35	1	11	2	13	27
				2	5					2	2					
				3	6		2			3	5				2	2
				4	4	8		2		8	18			2	3	5
		1	1	2	27	1				2	3					
				1	6	1					1	1			3	4
	3			16	21	2				3	5		1			1
1		3	2		26	13	2		2	22	39	3	4	5	9	21
11	14	8	11	77	804	97	51	18	19	138	323	11	19	12	63	105

Dentistry														Grand Total
Total	Carious decay III-IV	Carious decay I-II	Denture repaired	Detached inlay crown	Fracture of tooth crown	Pericoronitis	Gingivitis	Pyorrhea alveolaris	Stomatitis	Periodontitis apicalis purulenta chronica	Pulpitis gangrenosa	Pulpitis alcerosa chronica	Pulpitis purulenta acuta	
53	1	15	4	5	1	2	3	3	1	3	1	5	2	361
8		4	1			2				1				32
4		2	1											48
19		6	2		3				1		1			111
2														4
3		1		1			1							9
3												2		43
5		1					1					1		80
4		1					1					1		89
7		2					1		1			1		50
9		1		2								1		110
4		1												34
14		3		2								1		94
8		3					1							138
1				1										8
3								1						16
3									1					34
10		8												40
11	1	3		2			1	1				1		26
														27
31		6		1				1				2		126
202	8	60	17	14	14	16	9	6	5	16	2	13	9	1,480

Medical Services at Detached Villages

Oiso Detached
 Village Clinic: One Room of 26 sq.m.
 Karuizawa Detached
 Village Clinic: One Room of 13 sq.m.
 Hachioji Detached
 Village Clinic: One Room of 26 sq.m.
 Lake Sagami Detached
 Village Clinic: One Room of 33.6 sq.m.
 Service Period: Throughout the period of operation of the Detached Village
 Service Branch: Treatment mainly of an emergency nature
 Hours: 08:00 hrs—21:00 hrs
 (Except for emergency cases)
 Service Rendered: Examination, Prescription & Application of Medical Materials, Treatment and Nursing
 Organization of Detached Village Clinics:

Number of patients treated at clinics of Detached Olympic Villages

		Oiso	Karuizawa	Hachioji	Lake Sagami	Total
Surgical and orthopaedic diseases	Excoriation	4	6	31		41
	Contusion	1	1	8		10
	Laceration	5		10	5	20
	Fracture			3		3
	Sprain	2	2	1	1	6
	Head injury				1	1
	Strain		1			1
	Low back pain	2			1	3
	Arthralgia			2		2
	Hemorrhoid	2		3	1	6
	Blister & shoe sore			2	1	3
	Athlete's foot	2				2
	Others	7	4	12		23
	Internal diseases	Headache	2	1	2	
Pharyngitis & tonsillitis		6	3	10	14	33
Common cold		20	9	26	5	60
Gastroenteritis		1	2	9	4	16
Abdominal pain & diarrhoea			2			2
Others		4	2	14	5	25
Disease of eye		5	2	14	1	22
Disease of nose & ear		1	2	2	2	7
Dental disease		1	3	2		6
Other disease			1	15		16
Total		65	41	166	41	313

Number of patients treated at first-aid clinics of sports venues

	Surgical and orthopaedic diseases									
	Head injury	Sprain	Fracture	Laceration	Strain	Myalgia	Low back pain	Arthralgia	Others	Total
Opening Ceremony									1	1
Closing Ceremony					1					1
Athletics	2		6	22	7	1			5	43
Rowing				3	1	2		3	12	21
Basket-Ball	1	1	1	2					5	10
Boxing	1	1		27			1		7	37
Canoeing				2		7				9
Cycling			1	6					1	8
Fencing	1		3	49		2		1	2	58
Football		1		7						8
Gymnastics			2	3	2	1			4	12
Weight-Lifting				2	1	1	1		2	7
Hockey	3	1	1	25		1			15	46
Judo			3						1	4
Wrestling	6	3	11	15		2		1	15	53
Swimming & Diving	1			9					2	12
Modern Pentathlon				2						2
Equestrian Sports										
Fencing										
Volley-Ball			5	5					3	13
Water-Polo	1	1		5					1	8
Yachting			2	16					6	24
Sub-Total	16	8	35	200	12	17	1	6	82	377
Spectators & others	21	3	54	454	2	27	23	20	314	918
Total	37	11	89	654	14	44	24	26	396	1,295

Medical Services at the Olympic Sites

A Medical Treatment and Relief Station was set up at each Games site.

Service Period: During the whole period of the Games
 Hours: From the opening of gates until all spectators had left the area
 Services Rendered: Examination, Prescription and Application of Medical Material, Treatment and Nursing

Standard Personnel Allocation of the Medical Treatment and Relief Team:

Type	Doctor		Nurse	Clerical Personnel
	Physician	Surgeon		
A	1	1	3	1
B	1		2	1
C		1	2	1

Organization of the Medical Treatment & Relief Room:

Typical Arrangement of Medical Treatment & Relief Room :

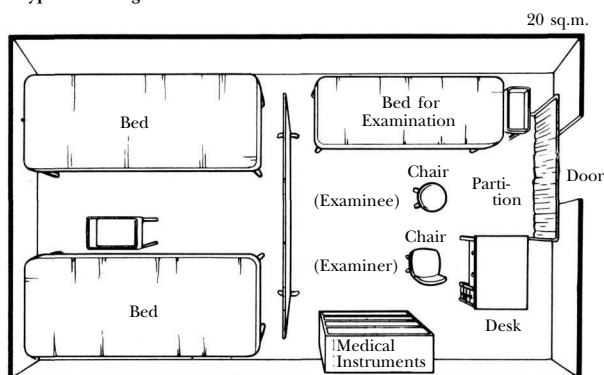

Number of Patients Treated: Services were rendered as shown in attached Tables

Internal diseases													
Headache	Fever	Common cold	Pharyngitis and tonsillitis	Gastritis	Enteritis	Others	Total	Disease of eye	Disease of nose and ear	Dental disease	Other disease	Total	Grand Total
						1	1		1			1	3
4		3		1		7	15					1	1
1		4	1			3	9					2	58
1		1		2		1	5					2	30
						1			2				15
						2	1						37
1		3	2	1		2	9						11
1				1			2						9
2		2		1			4						67
1		1				1	3						10
2		1	1	1			4						16
		1					1						10
		4	1	6	2	1	16	3	7	1	1	12	50
2	1	4	1	1	1	1	12	2				2	5
3		4					2						81
1							1						26
							1						4
				1		1	2	2				2	0
2		1		2			5						4
1							1	1	1			2	18
		6					6	2	7			9	11
		30	6	16	3	20	98	10	18	1	1	30	39
22	1	30	6	16	3	20	98	10	18	1	1	30	505
433	30	1,124	214	461	134	559	2,955	91	39	90	34	254	4,127
455	31	1,154	220	477	137	579	3,053	101	57	91	35	284	4,632

Medical Services at the Sites of Training

First-Aid Kits: Each Administrative Office was furnished with a first-aid kit for immediate treatment of minor injuries.

Services of Detached Medical Treatment and Relief Team:

Medical Teams, consisting of the Defense Agency and the Japan Red Cross personnel, were detached and engaged in patrolling services mainly around training venues where injuries were thought more likely to occur.

Medical Services at Other Facilities

Designation: Clinic for the Yoyogi Village Employees
Service Period: 21st September 1964–24th October 1964
Hours: 10:00 hrs—16:00 hrs
Services Rendered: Same as Detached Villages

Contracted Medical Treatment Treatment at Contractor Hospitals—

For the Olympic athletes and officials, fully equipped hospitals near the Villages and Games sites were entrusted with medical treatment beyond the capacity of the medical facilities prepared by the Organizing Committee. Contracts were made in advance in regard to the treatment and accommodation of the sick and the injured.

Medical Expenses of Contractor Hospitals The contract period was from 15th September 1964 to 5th November 1964 and negotiations on the amount of medical expenses were conducted with the hospitals through the Physicians Association of Tokyo and other organizations. The fees were based on standard charges to patients at private hospitals or on the charges stipulated by the relevant public hospital regulations. Patients accommodated in the hospital beyond the contract period were, in fact, treated as within the contract term.

Emergency Accommodation in Hospitals Serious cases among spectators requiring treatment outside the capacity of the medical facilities at the Games site were accommodated in the nearest hospital as emergency cases.

Sharing the Medical Expenses Costs of medical treatment on the site, of athletes, officials and spectators alike at the medical facilities, were borne by the Organizing Committee. Expenses at the contractor hospitals during the Games period were also borne by the Organizing Committee in the case of athletes and officials and expenses for the period other than that covered by the contract were to be

paid by the patient. Expenses of spectators for emergency hospitalization were charged to the individual concerned.

With the cooperation of hospitals and other medical facilities, a total number of 9,100 persons were in effect engaged in medical services (1,900 doctors, 4,600 nurses and 2,600 other persons, including masseurs).

Inasmuch as these were the first Olympic Games to be held in Asia, some of the participating countries despatched medical research groups to Japan during the year preceding the Games to study climatic conditions, environment, sanitation conditions, etc. Some 120 doctors from 60 countries were in Japan also as officials of the participating team.

No serious illnesses or injuries were reported or any significant number of patients treated except that (1) there was a significant number of cases of bronchial infection such as colds caused by the lower temperature and rain, during the early part of October, (2) Clinics of the Villages were in fact utilized to a greater extent than had been expected because of the superior facilities and medical advice available, and (3) a number of athletes were found to be suffering from physical troubles due to earlier training.

The Central Blood Bank of the Japan Red Cross performed a most important role in securing adequate supplies of uninfected blood and Rh serum to be used in emergency. Fortunately, however, none of this was required.

Cases treated at contracted hospitals

Complaint	Athletes		Officials	
	Male	Female	Male	Female
Internal	18	2	10	1
Surgical	46	2	21	3
Orthopedy	2			
Ophthalmology	3		1	
Dentistry	8		4	
Skin complaints	3	2	2	
Urinary disease			2	
Gynecology		1		
Total	80	7	40	4

Number of patients admitted to contracted hospitals

Complaint	Patients admitted
Appendicitis	4
Fracture	4
Hepatitis	3
Low back pains	1
Achilles heel severed	1
Contusions	1
Head injury	1
Duodenal ulcer	1
Miscarriage	1
Retina detachment	1
Total	18

Activities on Sanitation and Prevention of Epidemics

Activities on Environmental Sanitation Extermination of Rats and Vermin—

To ensure that no noxious insects or vermin were infecting dwellings at Olympic Village at Yoyogi, fumigation was carried out twice during the period.

Some Self Defense Force and Village cleaners complained they had been stung by insects after the disinfection work had been performed, and research was undertaken which revealed some brown larval poisonous moths on camellia and sasanqua trees near the athletes quarters. With the help of the Sanitation Department of the City Authority and the Shibuya Health Centre the moths were completely destroyed, and gardeners were assigned to prune off the affected branches and leaves.

Later, a number of winged ants were discovered near the shopping center of the Village and the Sanitation Department of the City Authority was again requested to destroy the vermin. It is believed that the unusually high temperatures was the reason for the appearance of this pest. (Table is included for reference).

Some of the facilities of the Tokyo Olympic Games were under the application of the 'Environmental Sanitation Law'. They included such places as:

Barber shop	Yoyogi Village
Barber shop	Hachioji Detached Village
Beauty parlor	Yoyogi Village
Laundry	Yoyogi Village

and two swimming pools, three public baths, two special baths (one steam bath for males and one for

females).

With the opening of the Games, surveillance disclosed a number of unsatisfactory sanitation factors, e.g., dirty toilets, shortage of the number of toilets, damages on buildings and incomplete ventilation system at theatres. These were remedied without delay and the overall sanitation standard was regarded as excellent.

Food Sanitation Most of the activities for food sanitation in the Olympic Villages and Games sites were within the responsibilities of the executive sanitation authorities concerned. The Organizing Committee prepared the 'Outlines of Medical and Sanitary Control' and surveillance and guidance were conducted in accordance with the regulations and food sanitation inspectors were dispatched on request.

The Organizing Committee also prepared 'Guides for Restaurants and Sales-stand Operation' to prevent fires and sanitation laxity and to ensure the smooth operations of restaurants and stands. No serious trouble was reported except for a minor incidence of food poisoning among employees at Oiso Detached Village.

Facilities of the Olympic Villages were under the direct control of the Organizing Committee. Full-time food and sanitation inspectors were assigned the main Village in Yoyogi throughout the period of its functioning. Six female inspectors were dispatched to the Women's Village to maintain surveillance on its proper operation and maintenance of environmental sanitation facilities, such as the beauty parlor.

Most of the actual Games sites were in the custody of respective managers of facilities with a few

Inspections maintained at pools and other facilities

Site	CO ₂ gas	Temperature		Water Temperature	Chlorine		Total No. of inspectors
		Indoor	Outdoor		Depth	Shallow	
National Gymnasium	0.04~0.07 ppm	24.5~29.0 °C	18.0~20.0 °C	24.0~26.0 °C	0.20~0.32 ppm	0.15~0.32 ppm	28
Tokyo Metropolitan Indoor Swimming Pool	0.01~0.08	24.0~27.0	20.5~25.5	23.0~26.0	0.10~0.35		17
No. 1 Pool Yoyogi Village			18.0~22.0	24.0~27.5	0.18~0.33	0.15~0.30	130
No. 2 Pool Yoyogi Village			18.0~21.0	24.0~25.5	0.20~0.30	0.20~0.30	130
Waseda Memorial Hall	0.047~0.08	25.0~28.0	24.0~26.0				24
Korakuen Ice Palace	0.0 ~0.04	22.5~24.5	14.5~23.0				
Nippon Budokan Hall	0.1 ~0.13	22.0~23.6	25.7~25.9				18
Tokyo Metropolitan Gymnasium	0.06	23.8~24.2	19.0~24.3				16
Shibuya Public Hall	0.05 ~0.8	15.0~26.0	13.0~21.0				29
Komazawa Gymnasium	0.0 ~0.2						34
Komazawa Volley-Ball Court	0.006~0.04						34
Komazawa Stadium	0.056~0.065						34
National Gymnasium Annex	0.12 ~0.9	24.0~28.0	13.2~23.0				42

exceptional cases which were under the control of the Organizing Committee. Complete advance guidance was provided by the Organizing Committee who worked in close cooperation with managers of establishments of each Games site, and close coordination was maintained with administrative offices concerned during the course of their construction from May 1964. During the period of the Games, offices were set up in the National Stadium and at the Komazawa site where many of these facilities were located and full-time food sanitation inspectors were stationed. Surveillance, guidance and inspections, including bacteria and chemical inspections, were conducted with the aid of food sanitation inspection cars on all sales items at the facilities. The names of the sanitation administrative offices are shown by facility in the Table in this section.

Many other persons were engaged in supplying foodstuff and in activities on busy streets adjacent to the Games sites, at sight-seeing resorts, training sites, along the route of the Marathon and Walking races, and in providing lodgings for sightseers or private accommodation, etc. Surveillance and guidance of these were carried out on the basis of earlier applications to the sanitary authorities concerned.

The food poisoning incident at Oiso Detached Village has already been referred to in an earlier paragraph. Twenty-seven members of a Boy Scout troupe suffered from food poisoning on 16th September shortly after the opening of the Village on 15th September. The box lunches had been prepared by the kitchen of the Oiso Long Beach Hotel Annex. Fortunately, food intended for the athletes and officials was not involved, having been prepared in a different kitchen. One of the members of the Soviet Union fencing team made an adverse report concerning a box lunch prepared by the Village restaurant. An immediate bacteria inspection was undertaken but revealed no dangerous food condition. The athlete concerned and his teammates were assured that all was in order.

There were, therefore, very few instances of trouble. Most of the facilities of the Olympic Games were newly built for the Games or were existing buildings acquired temporarily for the Games periods. Considerable effort, in fact, and careful planning by the staff concerned resulted in the prevention of any serious trouble or accident which would interfere with the Olympic Games and events.

Prevention of Epidemics With the knowledge that in Japan, 70% of the epidemic cases are traceable to dysentery, efforts were centered chiefly on dysentery prevention. The sanitation authorities were requested to instruct workers in businesses

and food and drink handlers to cooperate in the detection of dysentery germs. As a result, there was not a single case of dysentery among the workers in the Olympic facilities. Adequate measures were taken to deal with dysentery cases in other places and no Olympic personnel were affected by the disease during the period.

A number of the Games participants being required to travel to Japan through areas designated as epidemic areas, each National Olympic Committee so involved had been requested in advance to enforce preventive inoculations, and the sanitation authorities were also asked to encourage close observation on health conditions. Persons engaged in the operations and businesses connected with the Olympic events were given compulsory inoculations for cholera and smallpox inoculations. To expedite the isolation of infected patients, epidemic prevention and examination teams were sent to the Villages during the Olympic period. As a result, not even a suspected case was found within the facilities.

However, on 24th August, a cholera death of a Japanese citizen was reported in Narashino City, Chiba Prefecture, and later on 13th October, a second case was reported at Shimoda, Shizuoka Prefecture. This was immediately after the start of the Olympic Games. Since the second case occurred in the course of the Games and the patient lived in Tokyo, special care was taken with regard to food handlers among the commuters from the area. Fortunately, no further cases arose, and with adequate and immediate action by the authorities these two cases had no adverse effect on the Games.

Though the disease is not prevalent in Japan, preventative measures were undertaken to ensure that no cases of rabies occurred during the Olympic period. Unleashed dogs were controlled to prevent unexpected trouble caused by stray dogs. The Olympic Committee requested strict action on the part of administrations in catching stray dogs in and around the area of the Olympic Games during the period after August 1964. Stray dogs were caught by ordinary means and when necessary, with traps and in the early morning. The main Village at Yoyogi spread over a wide area of park land and it was consequently difficult to isolate completely or prevent dogs from entering. A total of 51 stray dogs were captured in this Village alone. A special request was made for the areas in which the outdoor events of Torch Relay, Marathon, Walk and Cycling road races took place in order to prevent accidents caused by stray dogs. There were no instances of trouble under this heading reported throughout the entire Olympic period.

COOPERATION OF THE JAPAN SELF DEFENCE FORCE

The scale to which the Olympic Games have grown has made the efficient administration a matter of some difficulty, and accordingly the Games of each Olympiad have made use of more highly trained personnel and mechanized devices and machinery more advanced than before.

In July 1962 the Defence Agency in Japan, in response to a request for assistance from the Organizing Committee, presented an outline of a programme of support involving the Ground, Maritime, and Air Self Defence personnel, and from that date took practical steps to implement this programme.

The principles under which cooperation would be offered were defined as follows:—

1. The Defence Agency shall, on request from the Organizing Committee for the Games of the XVIII Olympiad, and within the provisions stipulated in the relevant Self Defence Forces Law, render support needed for the administration of the Games.

2. This support shall be rendered to such sections of the Games administration as would be unable to execute their operations satisfactorily without the Agency's furnishing organized personnel and material, and to such other branches where the support of the Agency is deemed proper in the light of international practice during the Games of the Olympiads.

3. The Ground Self Defence Force shall render support where possible except for yachting and in the torch relay outside Japan.

4. The Maritime Self Defence Force shall support for yachting and boating events.

5. The Maritime and Air Self Defence Forces and their subordinate organs shall cooperate with the Ground Self Defence Force.

6. Requests, if any, for assistance for the torch relay outside Japan to be rendered by the Agency's aircraft shall be the subject of separate study and decision for any case so presented.

Within these stated bounds, the Defence Agency working in close contact with the Organizing Committee established the extent and period of support to be rendered, and also the personnel and material to be used. A support command was organized in September 1964, embracing in all some 7,500 personnel, 7 ships, 12 air-planes, 740 vehicles, and approximately 820 units of communications equipment, and three salute-guns.

The Ground Self Defence Force

The Support Command for the Ground Self Defence Force was staffed with 19 officers under a Commanding General. A complete and extensive system of training for the personnel concerned was undertaken, and adequate rehearsals of all aspects of the duties likely to be encountered were provided.

Support groups to be detailed to the Olympic Villages, Transportation and Rifle Marksmanship were organized on 15th August, and other remaining groups on 15th September 1964.

With the task nearing completion late in October, the Command began to relieve its units and groups of their duties, returning them to their original service posts, and on 20th November the Support Command disbanded itself, and reinstated the administration staff members to their former positions in the Agency.

The Tokyo Olympic Support Command Support Command Headquarters: Duties The command was in charge of preparation and execution of all aspects of the plan as defined above, including the employment of all subordinate support groups and units, to assist the operation of all the events of the Games (with the exception of yachting).

Organization The Organization can be seen from the following chart:—

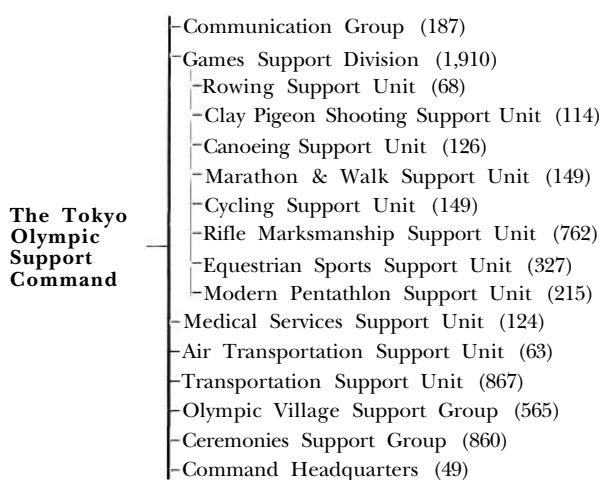

Outline of preparation for and enforcement of the support—

The support plan was virtually completed by the end of March 1964, and it incorporated the experience which had been obtained through the various sports meets to that date. From that date

until the opening of the Games, actual posting of personnel and matters involving practical application of specific details were completed.

Starting with the Opening Ceremonies on 10th October, the Support Command commanded 4,600 men and officers detailed from the Ground, Maritime, and Air Self Defence Forces, and the Defence Academy, and organized them into 13 groups and units, for the period of the Games lasting for two weeks.

On completion of their assigned tasks, the disbanding of the Support Command was undertaken beginning with those units detailed to the Clay Pigeon Shooting and Rowing (19th October). With the disbanding of the groups detailed to the Olympic Villages and Transportation on 5th November, the business pertaining to the dissolution of the groups and units under Command was completed. Finally with the disbanding of the Command Headquarters on 20th November, the Support Command duties were completed.

Ceremonial Support Group:

Opening and Closing Ceremonies—

- Band performance
- Handling of signs and signals
- Hoisting of the Olympic flags and national colours of participating countries
- Gun salute
- Communications

Hoisting of the flags at the medal awarding victory ceremonies, and band performances at the National Stadium, Toda Rowing Course, National Gymnasium, Lake Sagami, Hachioji Velodrome, Waseda Memorial Hall, Komazawa Hockey Ground, Nippon Budokan Hall, Kemigawa Playing Grounds, Equestrian Park, Asaka Shooting Range, Tokorozawa Clay Shooting Range and Sagami Bay were among the services rendered.

Execution and result of Support Official announcement that 94 nations were to participate in the Games was made at a liaison conference held at 9:00 a.m. on the opening day, and this necessitated some changes in the order of national flag displays. At 7:00 a.m. on the closing day, Northern Rhodesia became an independent nation under the name of Zambia, and this necessitated a change in the order of marches and national flags. Assistance for the medal awarding ceremonies were rendered through the hoisting of national flags and performance of national anthems during the period between 11th and 24th of October at some 19 venues, where a total of 156 medal awarding ceremonies were held, involving 535 man-days of signal personnel and 2,263 man-days of band personnel.

The bands of the Ground and Air Self Defence

Forces supported in the opening and commencement ceremonies at Olympic Village, Yoyogi and Hachioji.

Support Group for Olympic Village: The duties under this heading were to maintain a guard at the entrances to each national group, and to patrol the Village, to keep in custody apparatus and appliances, furnishings, and belongings for the use of the athletes, to assist in their distribution and repair when required, to transmit and distribute notices to the athletes of participant countries. To supervise the work of interpreters and helpers attached to the administration section, and of sweepers in the area administered, to handle flags and emblems, and the band performance at the opening and commencement ceremonies of the Village.

The guards were detailed to nine entrance gates of the Village to check the entrance and exit of people and vehicles, and to keep surveillance over the movements of goods. A patrol was maintained around the 600,000 square-metre area of the Village.

The duties of these personnel called for amicable tactful and sincere treatment of the officers and athletes of the participant nations of many different languages customs and manners. The 50 day duties included 8,200 rounds of paper document distribution, 1,500 pieces of needle-work, 2,100 clothes-pressings, and 1,700 repairs.

The flag and emblem duties were in addition to those on the occasion of opening and commencement of the Village, daily hoisting and furling of national flags of the participant nations. To this service, 30 personnel were detailed daily.

Support Group for Transportation: These duties included logistic support in jeep transportation services; transportation of sports goods, tools, implements, and equipment for the athletic events, between the venues, and between venues and the Yoyogi Olympic Village, and other villages; operation control of the motor vehicles loaned to the Committee for the transportation of officials and athletes from the Yoyogi Olympic Village to Games sites; auxiliary communications between the main transportation office and branch offices at the Haneda International Airport; and between the officers' billets and elsewhere.

Communications in relation to operation control of chartered vehicles.

The demands on the transportation units gradually increased as the games drew near. All the transportation to the venues were conducted to a precise time schedule and no delays were recorded. The precise and efficient manner in which the

7,500 participants were transported to the opening ceremony in 30 minutes using some 300 buses travelling over six different routes was evidence of the effectiveness of thorough pre-study and planning.

Helicopter Unit: This unit was entrusted with the transportation of officials in the equestrian events and modern pentathlon cross-country and other events held some distance in the country, and with emergency transportation of any sick and injured in the equestrian sports.

The unit was also available for urgent transportation of officials and athletes whenever such was deemed necessary.

Also included in these responsibilities were the transportation of personnel, equipment and supplies related to film recording, newsfilms, and TV-news, as well as communication services at and between the starting and finishing points, inspection points, hurdles emplacements and the central judging panels.

The operation employed 22 pilots and 10 helicopters and the assignments were carried out all without incident although on a number of days the weather was worse than had been expected.

The record of the units activities includes 68 cases of support to news personnel (TV hookups, record filming, and news movies), involving about 125 hours of flight. Emergency transportations of officials and athletes on 14 occasions, involved 56 persons. Transportation of the officials of equestrian sports, etc. on 12 occasions, involving about 12 flight hours. TV coverage of marathon, involved the flight over 42.195 kilometres over the entire route of the marathon, at an ultra-low speed of about 20 kilometres an hour, which called for highly developed flight technique. An emergency air-lift for hard breathing patients in the rowing was conducted on two occasions in cooperation with the Medical Support and Communication Group. The case was handled within 20 minutes, including transportation between the Games site and Sasaki clinic.

Medical Service: The duties under this heading included relief work carried out in shooting, modern pentathlon (only in cases of outdoor horseback riding and cross-country races), rowing, canoeing, and equestrian sports.

Deployed to the venues of Asaka Shooting Range, Tokorozawa Clay Shooting Range, modern pentathlon at Asaka Nezu Park and Kemigawa Playing Grounds, equestrian sports at Karuizawa, Toda Rowing Course, and canoeing at Lake Sagami, the unit opened field clinics where about 160 cases in training, and some 450 cases in the Games were

treated, involving officers, athletes, and spectators.

Modern Pentathlon: The duty of the unit assigned to the modern pentathlon events was to assist the panel of judges in the maintenance and weight checking of hurdles in cross-country riding.

To place course indicators, and their maintenance, and surveillance over the runners in the cross-country riding events.

To record, operate scoreboard, and to announce the names of participating athletes.

To pitch, maintain, and withdraw the tents at the venue headquarters.

To maintain the courses during the period of the events (limited only to the cross-country riding and running).

Transportation scoreboards, and tents by means of vehicles.

Communications between the hurdle points in the cross-country riding and running and the venue headquarters.

Thirty five tents were pitched up on Asaka Nezu Park on 8th October, completing all the necessary establishments including the venue headquarters. A rehearsal was staged on the opening day of 10th October on the regular course.

On 14th October, some members of the personnel were detailed to the assignment on the swimming venue while the major force was assigned work for the cross-country venue headquarters at Kemigawa. The unit rendered its support to seven events, which were held as follows:—

Venue	No. of personnel detailed
Asaka Nezu Park	All
Waseda Memorial Hall	20 (score display)
Asaka Shooting Range	20 (score display)
National Gymnasium	20 (score display)
Kemigawa Playing Ground	All
Equestrian Park	30 (score display)
National Stadium	All

Brigadier General Thofelt, Chairman of the International Union for Modern Pentathlon, sent a letter of citation for its rendered to the modern pentathlon events. A shield of honour was presented by the modern pentathlon team from Great Britain to the commanding officer of the unit.

In the grand prix jumping of the equestrian sports, the hurdles on the course, numbering some 700 pieces, were withdrawn in 13 minutes and 30 seconds out of a 15-minute break from the finishing of the game and the start of fanfare.

Equestrian Sports: The duties for these events were to supply water and power to all the equestrian sports events; to place, maintain and withdraw all the hurdles for grand prix jumpings which were held on Karuizawa Course and Equestrian Park.

For the three-day event were: assistance in judging; simple repairs of fixed hurdles; leveling and trimming of places of fixed hurdles; keeping in order of testing courses during the performance in D-area; transportation of a course survey team, and of batmen and recording papers during the performance.

Some 40 members of the personnel assisted in the dressage and jumping events held on 16th, 17th and 19th October while on the 18th, about 350 members including those from other branches of the Defence Forces were deployed over the entire course stretching over 30 kilometres, participating in the support of judging panels of 47 jumping events, and in the maintenance of order in the venue. Support was also rendered to the communications in these events, using 90 telephones and 20 wireless devices.

Rifle Events: Under these heading the duties involved supervision on shooting, and recording and surveillance of shooting actions; surveillance over targets; assistance to the judging panel of marksmanship; surveillance over the venue during the event; communications between the firing line and target trench, the venue headquarters and shooting ranges; transportation of officials on the venue.

The personnel assigned performed well a most important function during the events Mr. Kurt Hasler of Switzerland, President of the International Shooting Union highly praised the organization and management of the shooting events, particularly referring to the support rendered by the Defence Force contingent, and awarded the commander and deputy commander of the unit with a gold medal each with their names inscribed, and the commander of all the ranges with letters of citation.

Cycling: Duties of the unit involved the transportation of officials, drop-outs, spare bicycles and broken bicycles, communication between check-points, and between vehicles with officials aboard and the venue headquarters.

The Support rendered in the training covered over 25 days, involving 270 nationalities.

Marathon and Walking Events: Here the assigned duties were to maintain communication between check-points on the road walk and marathon courses, and with the venue headquarters,

communications on the premises of National Stadium, transportation of officers between the marathon and road walk courses.

One communications platoon was deployed at each check-point posted at five-kilometre intervals on Koshu Kaido Highway, and assisted the record relays and urgent message transmissions through employment of three radio carriers, 80 telephones, and some 20 units of wireless apparatus.

Support thus rendered for the duration comprised the following:—

- 15th: 20-kilometre road walk around the Meiji Memorial Gallery; 33 persons were detailed.
- 18th: 50-kilometre road walk on Koshu Kaido Highway; 149 persons were detailed.
- 21st: Marathon on Koshu Kaido Highway; 149 persons were detailed.

Complete assistance was given to the record and message transmissions and transportation of officers on the marathon course.

Canoeing: Duties Assistance on the starting line; surveillance over the venue from boats; communications between the boat with the judging panel aboard, surveillance boats, and starting pontoons; communication between starting pontoons and stick pontoons.

126 personnel were deployed around Lake Sagami. 30 telephones, 29 units of wireless apparatus, and 5 boats were used.

Clay Pigeon (Air Self Defence Force) : Duties of this unit included:—

Handling of pullers and traps on the venue, score-recording, and liaison work; surveillance over the venue during the performance; communication between the surveillance points and the venue headquarters.

For 3 days beginning 15th October, the unit assisted 54 athletes representing 28 nations. Each member of the unit operated nearly 140 rounds of clay pigeon flying and some 700 pullings a day. The score-recordings also were performed with accuracy, fairness, and precision.

Rowing (Air Self Defence Force) : Duties Assistance at the starting line; communications between the venue headquarters and the boat with judging panel aboard, operation vehicles, check-points, and Scoreboard.

In the five days from 11th October, the support operation to the rowing events were carried out in 56 races by using a total of 256 boats. The operation was carried out smoothly under favorable weather except on 15th October, when a strong northeaster delayed the start of the sports for one and a half hours, when the eight-oars with cox

final started at 17:25, well after sundown. On this occasion, the headlights of the unit's vehicles were used to illuminate the scene while five rounds of flare were shot as the competing boats neared the goal.

The Maritime Self Defence Force

The Yokosuka Area Squadron of the Maritime Self Defence Force rendered support for the yachting events, and also cooperated in the flag hoistings and band performances at the opening and closing ceremonies.

The specific duties involved:

Laying, maintenance, and withdrawal of the course-indicator buoys for yachting; communications on sea between the venue headquarters and the ships, and among the ships; support activities in the flag ship, and course guidance; the traffic control and safe-keeping of the participating boats, and assistance in harbour services on the venue sea area during the performance and in the yacht harbour; sea transportation of the officers, athletes, TV and press reporters, and equipment in the venue; sea relief work in the yachting races; handling of flags and emblems in the venue.

The preparations were commenced officially in June 1963.

Early in 1964, the harbour surveys, and testing of communications equipment and apparatus were conducted and at the same time training in the floating maintenance of buoys on the courses of the venue. The map maneuvers of the support operation were carried out in cooperation with the Japan Yachting Association. In the latter part of May, the unit participated in the Japanese elimination contest, and held an overall operational exercise, thus familiarizing the personnel with the practical aspects of their assignment.

In June, trainings were continued in buoy floatation, communications between launches, and gunboat loading. Map maneuvers were also repeated.

For two weeks beginning 1st September, further trainings were carried out in halting the launches and patrol boats near fore and aft of the flag boat, in relieving the yachts in distress, and in yacht operation. During this period 27 buoys indicating the race courses were floated on the venue. The base for inland support operation was readied by 15th September when an inland support unit was stationed.

Beginning 10th September, with the arrivals in succession of the foreign athletes, the support operation was begun and this involved around-the-clock patrol of the yacht harbour, helping the unloading and launching the training craft, sound measuring in the harbour, and clearing the harbour, furling

and unfurling of about 100 flags, and assisting the athletes in readying and safe-keeping of their crew.

With a typhoon approaching, all but one of the 27 buoys were withdrawn on 22nd and 23rd September. These were returned to original positions after the passage of the typhoon. Surveillance over the buoys was carried out by one to three boats and helicopters until the time of withdrawal.

Throughout the events, the Force's ship Yuchidori was placed at the service of the invited guests including The Crown Prince and Princess Akihito of Japan and other distinguished visitors, both domestic and foreign.

Other tasks undertaken by the unit included control over about 2,000 cars of the spectators mostly from Tokyo, safe-keeping of 170 yachts, handling the flags of participating nations, and assistance to the medal awarding ceremonies. All these tasks and assignments were successfully accomplished.

Air Self Defence Force

The First Air Corps began study early in 1962 for exploring the possibilities of staging an Olympic flight, as had been envisaged since 1960, by five F86F jets which were to describe five circles, each with a diameter of about 1,800 metres, at an altitude of about 3,000 metres. The Force and its Technical Research Headquarters undertook research into a practical five-colour tracer. The plan was officially adopted by the Defence Agency and the Organization Committee in July.

This flight called for, in the main, the training in circular flying to describe circles in mid-air and development of coloured tracers, particularly of black and green smoke, and improvement on the smoke discharge device of F86F jets. The flight was to be staged by the First Air Corps' acrobatic team which had to devise ways to link the five circles. Efforts were made to achieve development of continuous discharge of brilliantly coloured smoke and its suspension in mid-air for a fair length of time, and were finally rewarded with discovery of a process of spouting colours into the exhaust gas of a jet. The test flights of describing circles in the air through this process had been repeated several times until the process was developed for practical use in June.

The successful accomplishment of this task was a most gratifying climax to the long period of study, and the event formed an important adjunct to the impression Opening Ceremony programme.

Table showing supporting personnel and equipment

Area of support	No. of personnel	Aircraft	Vessels	Vehicles						Communication				Cannon	Collapsible boats	
				1/4	3/4	2 1/2	Ambulances	Cranes	Water tractors	Wired	Wireless	Switchboards	Generators			
1 Ceremonies	758			8	1	23					40	15			3	
2 Modern Pentathlon	215			12	2	16					25	7	1			
3 Equestrian Sports	327			45	3	8		2	2	100	28		2			
4 Shooting (Rifle)	762			20	1	15				90		2				
5 Shooting (Clay)	114			2	1					8	2					
6 Cycling	149			72	11	1				20	10					
7 Athletics	149			12	16	7				75	24					
8 Canoeing	126			5	2	5				30	20					5
9 Rowing	68			4	2					20	8	1				
10 Yachting	338 (1,888)	HX2	66	6	2	2					56					
11 Yoyogi Olympic Village	565			12	3	11				6	6					
12 Transportation	930	HX10		193	8	70				20	51					
13 Sanitation	124			16		2	9									
Sub-total	4,625 (1,888)	HX12	66	407	52	160	9	2	2	434	227	4	2	3	5	
Self Defence Adm. Personnel	312 (312)	HX12	6	62	22	26				91	21					
Total	5,345 (2,200)	HX12	72	469	74	186	9	2	2	525	248	4	2	3	5	

- Note:**
1. The total for the ceremonies were actually 860, though in the figure 102 were attached to the yacht events.
 2. The figures in parenthesis were handling personnel.
 3. H=Helicopter



Cadets from the Defence academy carry the placards bearing the name of each participating nation



The Self Defence Force Bands assisted at the opening & closing ceremonies and victory ceremonies during the Games

Motor control service performed by members of the Air Self Defence Forces at the Toda Rowing Course



The Maritime Self Defence units performed useful service during the yachting events



Placing bouys in position before the yacht races



IOC President Brundage has time to address members of the Ground Self Defence Forces assisting with the Tokyo Olympic Games







Duties were many and varied for the Defence Force units on duty for the Olympic Games
(upper left) During the modern pentathlon
(upper right) At the canoe events at Lake Sagami
(lower) Duties for the bicycle road races





(above) Members of the Air Self Defence unit before helicopter duty for the Olympic Games

(lower) The distinctive marking of the Tokyo Games on an ambulance helicopter used during the Games

Members of the Ground Self Defence unit assisting with the 300m rifle events





Ground Self Defence Force personnel performed important duties at certain of the victory ceremonies. Here is one such ceremony at the Toda Boat Course

POLICE ASSISTANCE

The Organizing Committee enlisted the assistance of the Police Agency, the Metropolitan Police and local police headquarters to cooperate during the Olympic Torch Relay within Japan, and subsequently in a wider scale during the Games themselves.

Organization of the Police Activities

Organization A Tokyo Olympic Games Police Headquarters was set up within the Police Agency, and this was under the direct central control of the Chief of the Agency. Relevant sections were also set up in those Police Headquarters in the areas adjacent to Olympic Games sites. Offices were established in Local Police Headquarters in those areas through which the Torch passed.

Local Guard Headquarters were also established in Police Stations covering each Games site, along the routes of the Torch Relay and the surrounding areas, and here again the Police Chief in each area was made responsible (District Commanders were nominated as chiefs of the organizations in the areas under the control of the Metropolitan Police Bureau).

An aggregate of 91,237 man days were devoted by the various police activities in connection with the Torch Relay and another 221,059 man days during the Games themselves, with special personnel being mobilized for a total of 98,739 man days.

Policy of police cooperation The following were the basic policies under which police cooperation was enlisted for the Tokyo Olympic Games.

- The police would assist the Olympic Organizing Committee, in close collaboration with the other organizations assisting in the Olympic Games, i.e., the Defense Force, Fire Defense Agency, etc., to ensure the smooth operation of the Games and such special events as the Torch Relay, etc.
- The police would direct the general traffic as well as that of the Olympic games by controlling and regulating the flow of traffic, making use of the Traffic Information Centre, etc.
- Special policemen would be assigned and pipe barriers, ropes and other materials would be provided to control spectators, in this way relieving congestion and preventing accidents.
- Special guards and escorts would be provided for Their Majesties The Emperor and Empress of Japan; The Crown Prince and Princess; other members of the Imperial Family; Foreign

Royalty; and other Dignitaries.

- The police would give protection to the lives and property of Olympic athletes and officials.
- The police would take appropriate action to ensure the safety and order of the general public, and to ensure that both foreign visitors and Japanese nationals alike should not be subjected to unpleasant incidents of any kind.

Police Activities for the Torch Relay within Japan

With due regard for the conditions and the volume of traffic along the routes which the torch would pass, controls and regulation were instituted by means of road blocks, detours, parking restrictions, and prohibition of traffic from proceeding in the same direction as the Torch carrier group or from overtaking the group. Patrolmen and motorcycle policemen were detailed to direct and guide spectators along the route and areas surrounding the actual sites of the various programmed ceremonies.

The Olympic Torch was most enthusiastically received wherever it appeared, and in many sections the streets were more crowded than had been initially expected. An estimated total of 28,700,000 persons in Japan watched the Torch relay, and the orderly directing of this number of spectators consumed 91,237 police man-days.

In congested areas near the relaying points and the sites of the Torch relay ceremonies, crowds of spectators at some points poured out into streets and this resulted in some minor injuries. No serious difficulties were however encountered and the entire relay was successfully conducted in an exemplary manner.

Police Activities during the Tokyo Olympic Games

From 15th September the opening day of the Olympic Village, until 24th October the day of the Closing Ceremony, approximately 4,420,000 man days were involved, directly or indirectly in work connection with the Olympic Games, some 221,059 police man days were concerned with the various activities which were the responsibility of the police.

Traffic control in areas adjacent to the Games Sites On the basis of several integrated studies and surveys, the police were able to plan effective traffic

control to ensure efficient control at the time of the Olympic Games, and at the same time minimizing the interference that this operation would have on the usual daily movements of the citizens.

With the complete orientation of traffic controls through public information activities and a high degree of cooperation on the part of the general public, no untoward incidents occurred during the control period, in the areas adjacent to the Games sites.

For Meiji Park and its surroundings, where many of the main events of the Games were to take place, Inner Circle Traffic Block Lines and Outer Traffic Limit Lines were set up around the National Stadium. For the other Games sites such as Komazawa Park, vehicles not bearing official stickers were not permitted to pass when local traffic conditions were heavy.

Policing activities on the Day of the Opening Ceremony

The Opening Ceremony was held at the National Stadium with 7,495 participants (5,558 athletes and 1,937 officials) from 94 countries and approximately 80,000 spectators in attendance. Their Majesties the Emperor and Empress of Japan and members of the Imperial family, Foreign Royalty, and many high ranking Japanese and Foreign officials were also present. A further approximately 82,000 spectators lined the area around the National Stadium and the Olympic Torch was welcomed by a crowd of some 104,400 persons as it passed along the final section of the Torch Relay.

From 08:30 hrs, the Police went on duty in the areas around the National Stadium and along the route of the Torch Relay respectively, with a police complement of 5,650 to guard and regulate traffic. These personnel were relieved at 17:00 hrs without any serious incident having been reported.

The crowd reached its maximum around 12:00 hrs–13:30 hrs. Some confusion did in fact occur near the National Railway stations servicing this area, some of the spectators arriving were not in possession of admission tickets and were directed in the direction of alternate stations to avoid further congestion.

Some confusion had been regarded as unavoidable after the close of the Opening Ceremony, but there were only a few such cases of short duration around the National Railway Stations and the crowd gradually disappeared in an orderly fashion from around 15:20 hrs. With the advance information announcements and adequate control and guidance of the spectators, no serious congestion occurred even at the time of departure of dignitaries and Games athletes and officials.

With the inner and outer circle traffic lines set up at strategic points, no cars other than those bearing

official stickers were admitted. Trucks without official stickers were not permitted to pass through or stop or park in this area, and the operation of city tramways were suspended temporarily. The extent of this planning and preparation was rewarded by a period of fewer accidents and traffic problems than had been envisaged—not only in the immediate area of the sports venues, but in Tokyo as a whole. There was however some times of congested traffic conditions for short periods of ten to twenty minutes in the areas controlled to allow speedy passage of athletes and officials. No delays were experienced by any of the athletes in reaching their destinations.

Police responsibilities on days the Marathon and other road races were held

Marathon—The Marathon event took place on 21st October on the road leading from the National Stadium to Tobitakyu, Koshu Kaido Highway, and sixty eight runners from thirty five countries participated. The number of spectators, estimated at 1,200,000 along the route, was some twice the number of those at earlier Asahi Marathon and Mainichi Marathon races, and the roads surrounding the railway stations servicing the immediate route became very crowded. The Metropolitan Police, using a force of 12,343, controlled traffic, established traffic lines by using pipe barriers and ropes, and dispatched police reserves to the areas where congestion could be expected. No serious incidents occurred in these areas.

At 11:30 hrs, inner circle block lines were set up around Meiji Park to prohibit the passage of vehicles not bearing official stickers. On the race roads of Koshu Kaido Highway and others, all traffic proceeding in the direction of Tokyo was halted from 12:00 hrs onwards. Vehicles other than those connected with the particular race were not authorized to pass along these roads from a set time before the start of the race until a set time after, except for those periods in which it was judged that it would not present an interference.

Pedestrians and vehicles were permitted to cross the roads at designated sections until five or ten minutes before the actual arrival of the head runner.

Inasmuch as the Marathon was held on a weekday, it had been expected that much greater congestion would occur. Traffic was however not seriously impeded and this was attributed to the willing cooperation of the public and to the fact that adequate information on the restrictions had been widely disseminated beforehand.

The Marathon took place without any mishaps,—one man did try however to join the race and jumped out unexpectedly on to the road. He was

quickly apprehended by policemen without any interference to the race.

50km Walk—The 50km Walk was held on the road leading from the National Stadium, to Fuchu, Koshu Kaido Highway, as turning point, with thirty four participants from nineteen countries taking part. It was raining early on the morning of 18th October and for this reason there were fewer spectators than had been expected. An estimated 160,000 persons lined the road. No serious trouble whatever was reported, and 7,472 police personnel were placed along the route, the same number as on the day of the Marathon race.

Cycling Race The Team and Individual Cycling races were held at the Hachioji Cycling Race Course on 14th October and 22nd October respectively. The team race with one hundred and thirty two competitors from thirty three countries attracted approximately 56,000 spectators, and the individual race with the same number of cyclists from thirty five countries was observed by 58,600 spectators. Police personnel assigned to these races numbered 1,697 and 1,236 respectively, and the events were completed without incident of any kind under this heading.

Three-day Event The Three-day events were held on 18th October at Karuizawa, Nagano Prefecture, and watched by approximately 25,500 spectators. No trouble was reported and 437 police personnel were in attendance for these events.

Police cooperation with other sports events Meanwhile other events were taking place. As many as 147,000 spectators were enjoying the events at the National Stadium (athletics and other games), the Tokyo Metropolitan Indoor Swimming Pool (Water-Polo); the Prince Chichibu Memorial Football Field in Meiji Park. About 35,000 spectators gathered in Komazawa Park where a football field, volley-ball courts, a gymnasium for wrestling and the hockey grounds were located. There were about 39,000 spectators at the National Gymnasium of the Yoyogi Sports Centre with the swimming pools and basket-ball courts, and approximately 15,000 spectators lining the Toda Rowing Course. Other Games sites with popular sports were filled to capacity with spectators for every event. Police personnel were stationed at these respective sites to regulate traffic and to guide spectators. No trouble of a serious nature took place at any of these sites during the entire Olympic period.

Police and the Day of the Closing Ceremony The Closing Ceremony of the Games was held at the National Stadium on 24th October with about

4,000 athletes and officials from 94 countries and 76,000 spectators present in the Stadium. Their Majesties The Emperor and Empress of Japan and many distinguished guests from abroad were also present.

The Grand Prix Jumping Equestrian events were held in the same Stadium immediately prior to the Closing Ceremony. The Metropolitan Police had set up their control headquarters at 08:30 hrs with 3,341 police personnel on hand. The organization of the policing activities was similar to that on the day of the Opening Ceremony and proceeded smoothly and efficiently.

Policing precautions to obviate incidents In some areas of the Olympic games it had been anticipated that incidents might occur in connection with the judging of the events, and precautions were taken to prepare for such on eventuality. Close liaison was maintained with Organizing Committee officials and order was maintained at all times.

Police activities in the Olympic Villages and the surrounding areas The Olympic Village at Yoyogi was opened on 15th September and housed 6,131 persons (5,368 male and 763 female) from 94 countries. A guard force was organized with 136 security personnel (including 32 policewomen) headed by a superintendent. The duties of the Guard Force were to guard the athletes and officials in and around the Village and to regulate traffic at the gates. The guards performed their duties in an exemplary manner and no trouble of a serious nature was reported.

In and around the Detached Villages at Hachioji, Oiso, Lake Sagami and Karuizawa, necessary police control was maintained, again without any incidents.

During the period, (15th September to 5th November), which the Olympic Villages were open, police personnel collectively devoted the following number of man days to their guard duties: 5,406 from the Metropolitan Police Board: 1,581 from the Kanagawa Prefectural Police Headquarters: 785 from the Nagano Prefectural Headquarters.

Police assistance with the transportation of athletes and officials Traffic controls, such as bans on parking, were enforced on designated roads linking the Games sites with the Olympic Villages, thus securing safe and smooth transportation of the athletes, officials and other personnel, and the general public. Police motorcycles and/or patrol cars escorted the vehicles carrying athletes to Games sites. A special Patrol Detachment was despatched by the Metropolitan Police Board to the Main Village at Yoyogi to assist in the transportation of the

athletes and officials.

Motorcycle police escorts assured foreign dignitaries priority on the roads, guided the vehicles of foreign visitors, and persons with important duties connected with the Games.

Car parking Accommodation of cars presented a major difficulty owing to the limited parking space available. The Olympic Organizing Committee set up temporary parking lots, issued stickers to preclude unauthorized parking and, through publicity, encouraged the use of public transport instead of private cars, to minimize the number of persons requiring parking space. As a result, there was no difficulty in accommodating cars and these were within the capacity of the facilities provided. At each parking lot, student part-time workers assisted the police responsible for regulating traffic. Even on the day of the Opening Ceremony when considerable difficulties had been expected, the space occupied by cars was lower than estimated, requiring only 76% of the total space allocated.

Centralized traffic control service with Traffic Information Centre A Traffic Regulation Headquarters was set up within the Traffic Information Centre of the Metropolitan Police, and charged with the responsibility of minimizing the inconvenience of the traffic controls enforced for the Olympic Games. 220 places were designated for the collection of traffic information by appointed officials who fed the Information Centre with appropriate data.

Throughout the entire period of the Games, traffic was orderly and reports of congested conditions, though few, were quickly located and promptly dealt with.

Police communication To facilitate the activities of the police, some 1,500 temporary telephone channels were set up for the Guard Headquarters, and a large number of portable communication and electronic equipment items (some 25,000) were provided at strategic points. A signals corps was organized to set up and maintain these communication facilities. The personnel mobilized under this heading numbered as many as 281 a day.

Opening of the Interpretation Service Centre The Metropolitan Police, from the 15th September, established an Interpreters Service Centre with 118 personnel, 61 of them interpreters. The services were offered in any emergency involving overseas visitors. Another 350 policemen fluent in English and other foreign languages were assigned to the Headquarters and to patrol duty to assist foreign visitors. Up to 5th November 1964, 2,296 requests

for these services had been handled by a work force of 4,309 man days.

Policing activities at Haneda Airport, the Port of Tokyo and Yokohama, etc. The number of interpreters and policemen was increased at Haneda Airport, the Port of Tokyo and the Port of Yokohama, and other points where Olympic athletes, officials and foreign dignitaries, including official guests, would arrive and depart. Reinforcements were also dispatched for guard duty.

During the period 1st September to 16th November, from Haneda Airport alone, 12,369 persons from 99 countries entered and 7,698 from 88 countries departed from Japan. A total of 6,705 policeman days were devoted to this surveillance. Five cruise ships (serving also as floating hotels) were anchored in Tokyo Harbour during the period 8th to 26th October. Another 5 ships anchored at Yokohama from the 9th to 19th October. 509 man days of police work were required for this work in Tokyo Port and some 1,006 policeman days at Yokohama Port.

1,348 policeman days were required at the Niigata Port where athletes from North Korea arrived and departed before the actual games commenced.

Police control of sporting guns and ammunition 314 athletes from 53 countries had permission to bring in 450 guns (220 pistols, 148 rifles and 82 shotguns) into Japan as personnel effects.

Firearms being rigidly controlled in Japan, care was taken to ensure that such weapons once brought into Japan would not be disposed of illegally. This was confirmed by inspections, in cooperation with the Customs officers, either at the time of packing at the Olympic Village (by the Metropolitan Police) where custodian responsibilities were taken, or at the point of departure from Japan.

Arrangements for car driving licences by foreign visitors Japan became a signatory to the relevant International Treaty on Road Communications, on 6th September 1964. This meant that International driving licences would be valid in this country and could, on request, be issued here. The number of requests for licences to drive motor vehicles in Japan was fewer than had been anticipated, even though special facilities to issue these had been arranged by the Organizing Committee.

AUXILIARY ASSISTANCE BY THE FIRE SERVICES

It was in principle the responsibility of the Organizing Committee to provide adequate fire prevention measures, and organize efficient methods of crowd control, making ample provision in case of accidents or emergencies at all sports sites, as well as seeing that fire control measures at all related facilities including the Olympic Villages were adequate. Accordingly, the Committee set up a Stadium Section within its Secretariat to organize these facilities, and arrangements were made with the Tokyo Fire Defense Board and all other fire services concerned to provide full cooperation at the time of the Olympic Games. The Organizing Committee was grateful to receive the full support and cooperation not only of the facilities of the Fire Defense Board in Tokyo but also those in all the

First-aid squads were always alert for call, especially in athletic events and during the marathon



outlying areas where any Olympic installations or sports sites were situated. During the actual Games some 10,475 members of the fire service personnel were involved in duties of controlling the movement of crowds at sports sites, working under the direction of the chief of the Stadium Office of the Organizing Committee. These personnel supervised the students who were used to assist in ushering and guiding duties within the various stadiums and sports sites.

A special station was set up for the purpose of organizing accident prevention and the patrolling of Olympic Villages. Fire engine units and emergency relief units were assigned to strategic points and stretcher units were despatched where deemed expedient.

Liaison and Cooperation between Fire Services

Though the greater part of the sports sites for the Tokyo Games were in the Tokyo Metropolitan area, a number of these sites were actually scattered over the neighbouring prefectures, and fire defense duties in those areas were, under the Japanese regional control system, initially the responsibility of the respective local fire services concerned.

The Tokyo Fire Defense Board, in consultation with the Fire Defense Board of the Ministry of Internal Affairs, set up the "Neighbouring Prefectures Fire Defense Liaison Committee," to assure a unified system of fire fighting measures.

Advice and Guidance on the Construction of Sport Sites and Other Facilities

In the construction, or extensions to existing buildings or during the reconstruction of the National Stadium, the National Gymnasium and all other sports sites, as well as in the construction of the many temporary structures (especially temporary stands), executive officers of the Tokyo Fire Defense Board were included as members of the Facilities Committee of the Organizing Committee and rendered advice on technical safety factors during the basic planning stages.

Fire Prevention

At all sports sites and related facilities, including the Olympic Villages, adequate fire prevention and

safety measures were specifically and minutely defined and all employees were fully instructed in safety measures to prevent accidents.

Prior Inspection of Related Facilities

Detailed inspections of safety factors were carried out upon completion of the construction of all sports sites, Olympic Villages and related facilities, and a number of confirmative inspections were conducted. Inspections were also made of inns, hotels and private dwellings which were to be used to accommodate officials or other persons concerned with the Games, including tourists. The entire Torch relay course and the marathon road course were carefully checked to eliminate any possible fire or safety hazards which might have endangered the participants or spectators.

Guarding Structure

During the actual Games, a total of 26,813 members of the fire service personnel, including prior inspecting officers were placed on duties at the respective sports sites. Elaborate guarding plans were mapped out, by envisaging appropriate control structure and emergency relief and protection structure to meet the scale and nature of each sports site in any emergency. Special and detailed plans of action had also been issued to each sports site from June to the time immediately prior to the opening of the Games.

The composition of the fire patrol units differed somewhat according to the size and sports event involved. In the case of gymnasiums, 1 inspecting officer was allocated roughly for every 250 spectators, while in the case of the stadium, 1 inspecting officer was allocated for every 500 spectators. The officers assigned were either of stationary or fixed, patrol and special units.

In the first aid units, 1 unit was assigned generally to each sports site with the exception of the National Stadium which had special facilities, 1 unit being composed of 4 members.

In the stretcher units, 2 units (each consisting of four) were generally assigned to each sports site other than the National Stadium and other special stadiums where more elaborate precautions were regarded as necessary.

Fire engine units, each unit composing seven members were assigned, in principle, to each sports site. At the National Stadium, 4 fire engines (2 with pump and 2 with extension ladders) were on duty at all times.

The table relevant to this section shows the actual planning of ambulances and fire engines at the vari-

ous sites.

In the Marathon, Walking and Cycling road races, careful consideration had to be given to the possibility of emergencies requiring the fire fighting or first aid units, inasmuch as certain streets and areas would be closed to traffic during these sports activities. To meet these envisaged possible emergencies, arrangements were made to change somewhat the specific areas of responsibility to afford adequate coverage by transferring units from elsewhere without interfering with the roads assigned to these sports events.

In the Olympic Village itself, a special fire station was set up in the compounds, and 2 fire engine units, 1 ambulance unit and 26 inspecting officers were stationed on full time duty. In addition, 1 fire engine unit was stationed at the Village at Hachioji and 1 ambulance unit for the Press Centre.

Along the torch relay course, inspecting officers were stationed at strategic points and cooperation was provided by members of the Municipal fire departments concerned.

Performance of Inspection and Guarding Services

For the duration of the Olympic Games, the fire engine units despatched to sports sites, road race courses and Olympic Village totalled 476 units and guarding officers 3,174 persons.

Emergency relief and protection. Despatch of relief units Assignment was made on either a permanent or temporary basis, according to the nature and position of the facilities involved.

Permanent assignment was adopted for the Olympic Village at Yoyogi and the Press Centre, and one guarding unit was on full time duty at each, while temporary assignment was arranged for all sports sites, as can be seen from the details in the Table herein.

A total of 710 stretcher units composed of 2,212 members were organized and assigned temporarily to stadiums. These units were dispersed within the stands and were responsible for initial first aid and transportation of patients to the nearest medical station.

For the marathon and 50km walking races respectively, 3 relief cars followed the participants to afford relief service where required.

Olympic Village:

During the 52-day period in which the Olympic Village was opened for service, a total of 29 persons were treated by these units (27 of these were overseas participants, and only 4 were of a serious nature).

Sports sites:

During the 15-day period in which the sports events took place, a total of 3,396 persons were treated and of these 2,043 were participating athletes and officials.

The Press Centre:

11 Foreign correspondents received first aid treatment.

At the time of rehearsing for the Opening Ceremony and also during the Torch relay, the emergency relief units and liaison officers were despatched by the respective districts concerned.

Inspection In the coverage of the Opening Ceremony, which was the largest function of the Games, care was given to afford efficient and stringent controls to prevent disorder which could arise if unauthorized persons (even those in possession of ID cards) were allowed to have free access. For this purpose, the Tokyo Fire Defense Board, and the Stadium and Ticket Division of the Organizing Committee, after detailed consultations, agreed upon precise times for the opening of gates and the special events on the opening day (such as the releasing of balloons and fireworks which could by attracting attention affect the smooth flowing of crowds). The Tokyo Fire Defense Board, on its part, allocated a total of 154 officers, consisting of 62 stationarily assigned officers and 42 patrol inspecting officers inside and outside of the stadium as the nucleus and members of the Board's personnel, and these were reinforcement by 800 officers for stadium control to afford maximum and efficient control of all aspects of the stadium.

A late request was made by certain sports organizations for admission of their officials numbering as many as 800. Upon prompt consultation, it was arranged that these persons would be allowed to stand on the uppermost tier of the back stand, at which area they would not materially interfere with the emergency escape system for the rest of the spectators.

Inspection of sports sites:

At each sports site, emphasis was given to the regulation of admission on the one hand, and on the other the control of smoking, elimination of obstacles at emergency escapes, and appropriate operation of emergency escape facilities, fire fighting equipment, fire and electric facilities and appliances. For this purpose, Inspection Headquarters headed by the chief of the local fire station concerned were organized at each site, and in all a total of 9,502 inspecting officers were on duty at these various sites. Some 4,399 cases of smoking control, 3,019 cases of clearing roads etc. of obsta-

cles to emergency escape, 111 cases of maintenance and operation of fire fighting equipment, 90 cases of fire and electric appliances and 6 cases of admission control, that is 8,218 cases in total, were disposed of successfully before any accident happened.

Surveillance of the Marathon, Walking and cycling roads:

On the day of the Marathon race, 291 inspecting officers from the seven local fire stations concerned were on duty. On the 50km road for the Walking race 238 officers from the eight stations; and along the cycling road (team race) 98 officers from the three stations were assigned. Through these careful arrangements, a total of 168 cases of elimination of hazards, (including 71 cases of dangerous acts as inspecting of the races from rooftops) were dealt with.

Inspection of Olympic Villages:

The greater portion of facilities in the Olympic Village at Yoyogi were wooden buildings and accordingly special emphasis was given to fire prevention. While the participating athletes were using the facilities, inspection was made only from the outside. However, while the occupants were out, inspection was made of the interior of all buildings in accompaniment with Olympic officials. This was the established policy of all inspections. 26 inspecting officers were permanently stationed at the fire station in the main Village, and this Village was divided into 8 blocks. Detailed inspections were made of dining halls and theatres thrice a month, and once a month of all accommodational facilities. While the theatre was in use, 2 or 3 officers were on duty on a stationary basis. In the Village at Hachioji similar service was performed by 10 inspecting officers.

From the opening of Villages in September 15 to their closing on November 5, a total of 24,746 building inspections were made. For the 52-day period including the peaks of village population on October 12 and 13, guidance was given in respect of 989 cases, consisting of 594 cases of maintenance, operation and improvement of fire fighting equipment, 211 cases of proper use of appliances, 26 cases of proper use of electric facilities and appliances and 3 cases of control of admission into the theatre.

The overall fire and accident prevention system worked most efficiently, and the detailed organization and control organized in advance was to a large extent to be credited with the smooth functioning of these services.

Allocation of Fire Detachment Personnel to various sports sites

Sports site	Events	Hq. personnel	Inspection personnel	Stretcher personnel	Emergency personnel	Security personnel	Supporting personnel	Days involved	Cumulative total	Fire organization
National Stadium	Opening & Closing Ceremonies ; Equestrian Sports; Athletics; Football	140	150	64(16)	32 (8)	28(4)	601	2	2,029	Tokyo Fire Agency
Prince Chichibu Memorial Football Field	Football	182	146	64(16)	24(6)	28(4)	360	10	8,475	"
Tokyo Metropolitan Gymnasium	Gymnastics	16	34	8(2)	4(1)	7(1)	30	5	510	"
Tokyo Metropolitan Indoor Swimming Pool	Water-Polo	16	62	16(4)	4(1)	7(1)	70	6	890	"
National Gymnasium	Swimming & Diving	11	21	8(2)	4(1)	7(1)	15	7	458	"
National Gymnasium Annex	Basket-Ball	47	68	32 (8)	4(1)	7(1)	108	8	2,180	"
Shibuya Public Hall	Weight-Lifting	2	44	16(4)	4(1)	7(1)	52	11	1,187	"
Komazawa Stadium	Football	9	34	16(4)	4(1)	7(1)	20	7	624	"
Komazawa Gymnasium	Wrestling	21	48	24(6)	4(1)	7(1)	45	7	1,184	"
Komazawa Volley-Ball Court	Volley-Ball	16	42	16(4)	4(1)	7(1)	42	8	1,015	"
Komazawa 1st Hockey Ground	Hockey	12	26	8(2)	4(1)		23	10	730	"
Komazawa 2nd Hockey Ground	Hockey	3	9	8(2)			10	12	380	"
Komazawa 3rd Hockey Ground	Hockey	10	9	8(2)			10	10	370	"
Equestrian Park	Equestrian Sports	1	4	8(2)	4(1)		10	9	243	"
Waseda Memorial Hall	Fencing	8	9	8(2)	4(1)	7(1)	10	2	92	"
Korakuen Ice Palace	Boxing	12	34	16(4)	4(1)	7(1)	30	12	1,178	"
Nippon Budokan Hall	Demonstration ; Judo	17	17	8(2)	4(1)	7(1)	10	12	751	"
Hachioji Velodrome	Cycling (Pist)	17	51	8(2)	4(1)	7(1)	60	5	736	"
Hachioji Cycling Road Race Course	Cycling (Road Race)	18	27	8(2)	8(2)	19(3)	10	4	510	"
Yokohama Cultural Gymnasium	Volley-Ball	47	82	44(11)	24(6)	113(26)	15	2	570	"
Mitsuzawa Football Field	Football	5	15	6(3)	4(1)	7(1)	63	10	980	Yokohama City Fire Dept.
Enoshima Yachting Harbour	Yachting	5	30	4(2)	4(1)	7(1)	110	6	1,020	"
Lake Sagami	Canoeing	4	31		4(1)	5(1)	8	7	364	Fujisawa City Fire Hq.
Toda Rowing Course	Rowing	2	3			7(1)	2	3	72	Lake Sagami Town Fire Detachment
Asaka Shooting Range	Shooting (Rifle)	1	7			14(2)	4	5	130	Toda Town Fire Detachment
Asaka Nezu Park	Modern Pentathlon	2	14			14(2)	4	6	208	Asaka Niiza Town Fire Detachment
Tokorozawa Clay Shooting Range	Shooting (Clay)	2	14			12(2)	4	1	34	"
Omiya Football Field	Football	2	5	4(2)	4(1)	7(1)	22	3	120	Tokorozawa City Fire Hq.
Tokyo Univ. Kemigawa Playing Grounds	Modern Pentathlon	4	14	4(2)	4(1)	7(1)	116	5	920	Omiya City Fire Hq.
Karuizawa Equestrian Events Ground	Equestrian Sports	1	23		4(1)	7(1)	10	1	45	Chiba City Fire Hq.
Meiji Jingu Baseball Field Stadium	Demonstration	2	10			7(1)		4	76	Karuizawa Town Fire Detachment
Marathon & Walk Race Course	Marathon; 50km Walk	10	51			7(1)	100	1	168	Tokyo Fire Agency
Yoyogi Olympic Village		108	517		25(7)	145(24)		1	795	"
Hachioji Detached Village		1	26		5(1)	15(2)		52	2,444	"
			3			7(1)		52	520	"
Total									32,008	

1. The number of personnel allocated varied according to the event.
2. The figures in parenthesis for the emergency services indicate number of ambulances and fire-engines allocated. The figures in parenthesis for the stretcher personnel indicate number of teams.
3. Athletics, Gymnastics, Water-Polo, Swimming & Diving, Basket-Ball, Weight-Lifting, Volley-Ball, Fencing events were subject to a spectators shift system on certain days events.

To farewell the Sacred Olympic Flame



The athletes from all the participating countries move towards the Main Stadium for the Closing Ceremony



Led by Greece, the athletes of all the participating countries make their entrance

The Japanese flag bearer is shouldered by the crowd of athletes that overtook the markers as they burst into the stadium





The new flag of Zambia which officially gained its independence as a nation on the day of the Closing Ceremony is carried into the stadium for the Closing Ceremony



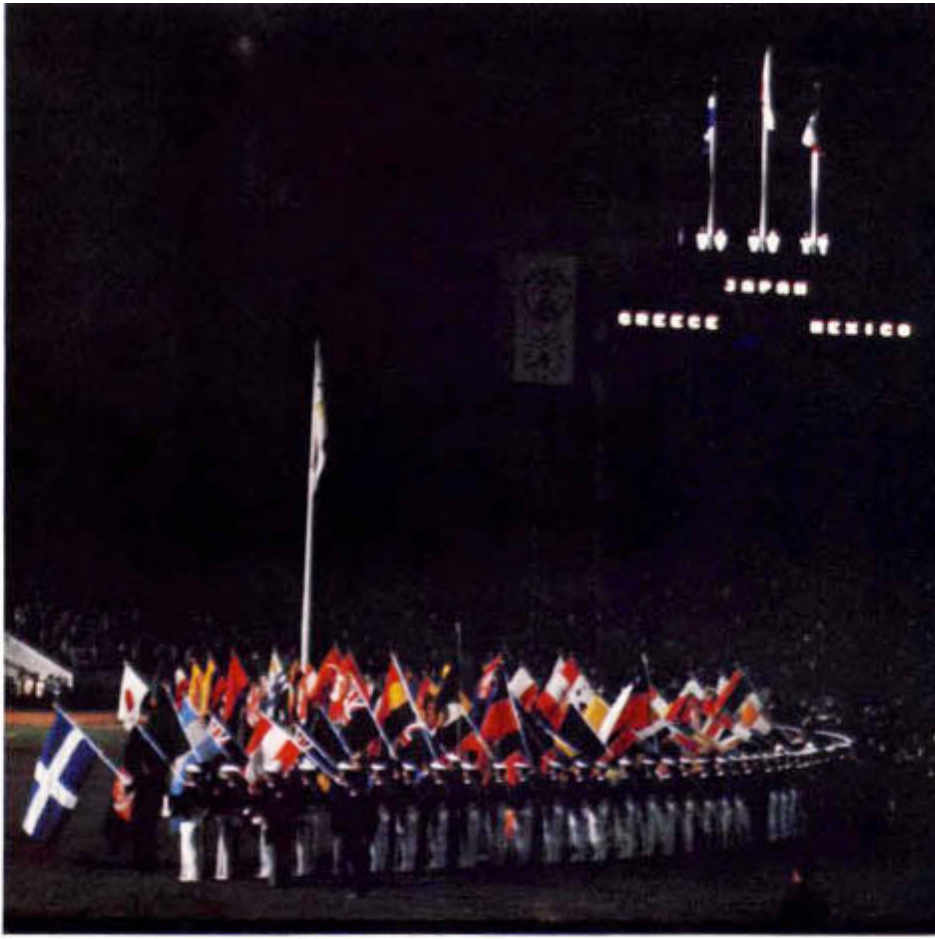

The flags of the 94 participating nation were dipped as the flags of Greece, Japan and Mexico were hoisted over the electronic bulletin board

View of the Main Stadium during the Closing Ceremony





The final fanfare is played to signal the closing of the Games

The Olympic flag which had flown during the entire Games period is majestically lowered





The Olympic flag is proudly borne out of the Main Stadium where it has been since the Opening Ceremony



The exit of participants at the close of the ceremony

Both spectators and departing athletes wave handkerchiefs in the final farewells in the exit parade





The Japanese delegation leaves the stadium as the words "We meet again in Mexico City 1968" appear on the electronic bulletin board



The blaze of fireworks light the sky over the Main Stadium after the Closing Ceremony





To the strains of 'Auld Lang Syne' the torch-bearers round the stadium describe arcs of light in the darkened stadium. The words 'SAYONARA' (farewell) appear on the electronic bulletin board





Japanese folk dances brought participation from guests in the relaxed mood of the Farewell Party held in the Shinjuku Gardens for all Olympic Games participants

A job well done—

From left Daigoro Yasukawa, President of Organizing Committee; Avery Brundage, President of IOC; Shigeru Yosano, Secretary-General of Organizing Committee



LOOKING BACK

We are proud to be able to report that the Games of the XVIIIth Olympiad were brought to a most successful conclusion without any accident or untoward event to mar the detailed preparation extending over the five years. Our efforts were amply supported and materially assisted by all the departments of the Japanese Government concerned, by the Tokyo Metropolitan Government of this host city, and also by the unselfish efforts and physical and moral support of the entire population of Japan. It would be boastful for us to speak of the success in the organization itself, but we are pleased to refer to the great volume of letters which we have received expressing kind words concerning the Games themselves. These unsolicited testimonials were from athletes, officials, from the press both home and abroad, and from also the visitors who came to participate in these celebrations.

The International Olympic Committee in an unprecedented resolution was gracious enough to award the Olympic Cup, the Olympic Diploma of Merit, and the Count Bonacossa Trophy to the agencies and personnel concerned with the organiza-

tion of these Olympic Games. The Olympic Cup was presented to the Tokyo Metropolitan Government for their efforts in the successful preparation of these Games. The Diploma of Merit was awarded to Dr. Kenzo Tange, a professor of Tokyo University for his creative designing of the National Gymnasium, while the Count Bonacossa Trophy was presented to the Japanese Olympic Committee for its endeavours over the five years before the Games commenced.

The Tokyo Trophy, which the Tokyo Metropolitan Government respectfully offered has been approved by the International Olympic Committee as one of the honourable awards to be included with the Olympic Trophies in the future. It was the desire that this Trophy be awarded to those who display the highest qualities of sportsmanship. During the Tokyo Games, this new Trophy was awarded to the Swedish Yachting crew who bravely assisted the crew members of another country who had been thrown into the sea by the rough weather, then continued the race in which they were competing.

With the inclusion of the Tokyo Trophy, the awards which are made by the International Olympic Committee are six, viz.:—

- The Olympic Cup
- The Olympic Diploma of Merit
- The Fearnley Cup
- The Mohammed Taher Trophy
- The Count Bonacossa Trophy
- The Tokyo Trophy



The Olympic Cup relief which was presented by the International Olympic Committee to the host city Tokyo (at left), and a diploma (below)



The Count Bonacossa Trophy which was presented to the Japanese Olympic Committee (at right), and a diploma (below)



For those who were winners in their respective events, these will be remembered permanently, for these names have been carried into the main entrance of the National Stadium, and these names take up a conspicuous area two metres in height and some 54 metres in length along the face of the stadium entrance.

It will never be possible to accurately measure the results of the Games. We can not in tangible figures

calculate the comradeship engendered by the participants to the Games, nor the inspiration which these athletes have given to the countless millions of youth who have seen or heard these Games directly or by radio or television. Many acts of kindness and endearment have been brought to our attention, many more must remain unrecorded but live on in the hearts of those who know.

The Olympic Diploma of merit awarded to Dr. Kenzo Tange



The Tokyo Trophy which is now included with the awards made by the International Olympic Committee



Chronological Table of the Tokyo Olympic Games

1955

Oct. 10: Immediately after the 50th IOC Session in Paris on June of 1955 when the city of Rome was named for the site of the 1960 Games, the Tokyo Metropolitan Government begun its preparation of the second invitation to have Tokyo named the host city for the next Olympic Games this time the Games of the XVIII Olympiad. On this day, the Tokyo Metropolitan Assembly unanimously passed a resolution to invite the Games of the XVIII Olympiad to be held in Tokyo.

1958

Jan. 22: The Tokyo Olympic Preparatory Committee was established, headed by Prime Minister, Mr. Nobusuke KISHI, and soon nation-wide interest was focused on the invitation of the Games to Tokyo.

May 13: At the 54th IOC General Session in Tokyo, Mr. Seiichiro YASUI, then governor of Tokyo officially announced this city's candidature as the host city for the Games of the XVIII Olympiad, and handed a provisional replies to the questionnaire concerning the offer of the city desiring to host an Olympic Games, as stipulated in the Olympic Charter, to Mr. Avery Brundage, the President of IOC.

1959

May 26: At the 55th IOC General Session in Munich where both Dr. Azuma, the newly elected governor of Tokyo, and Mr. Yasui, the former governor, were present, Tokyo was named the city to host the Games of the XVIII Olympiad. Out of 56 votes Tokyo polled 34, leading Detroit, Vienna and Brussels by a wide margin.

Sept 30: The Inaugural Meeting of the Organizing Committee was held and the following business was carried out.

(1) A decision was made that the members of the Organizing Committee will number twenty-five together with three auditors.

(2) Approved the Regulation and Rules for the Organizing Committee. Mr. Tsushima, a member of the Committee and representing the Japanese Olympic Committee announced that all authority and responsibility concerning the hosting of the Tokyo Olympic Games which had been entrusted by the International Olympic Committee to the JOC in accordance with Olympic Charter were now delegated to the Tokyo Olympic Games Organizing Committee, which was later named the Organizing Committee for the Games of the XVIII Olympiad Tokyo 1964.

(3) Mr. Juichi TSUSHIMA was unanimously elected President. The president then nominated Seiichiro YASUI and Tsuneyoshi TAKEDA as vice-presidents, and Masaji TABATA as secretary general and these appointments were unanimously approved.

(4) The location of the office of the Organizing Committee was established at the Kishi Memorial Hall, that address at that time was 4-5, Surugadai, Kanda, Chiyoda-ku, Tokyo.

Nov. 30: At the 3rd Meeting of the Organizing Committee, Sports facilities and fundamental principles were decided and a budget of ¥168,000,000 was approved for the year 1960 (later this was revised to the sum of ¥123,550,000).

1960

Feb. 12-17: The 56th IOC General Session was held at San Francisco, Mr. Tsushima, President of OOC attended to report on the activities and the progress of the preparations of the sports facilities for the Tokyo Olympic Games. At that Session the executive board of the IOC resolved a restriction on the number of sports events for the Tokyo Olympic Games. During this period Mr. Tsushima made an observation tour to the 8th Winter Olympic Games in Squow Valley.

Feb. 26: The Organizing Committee at its 8th meeting decided the following matters.

(1) All sports facilities should be completed by the end of 1963 Japanese fiscal year (March 1964).

(2) Yachting events would be held on Sagami Bay, just off Enoshima Island in Kanagawa prefecture. Rifle and Pistol Shooting would take place at the Asaka Shooting Range.

The Swimming pool being newly constructed would have a seating capacity of 25,000 persons.

(3) Approval was given of the official mark for the Tokyo Olympic Games.

Aug. 13-23: The Organizing Committee sent two delegations to observe the Rome Olympic Games (August 25 to September 11).

Aug. 20-23: At the 57th IOC General Session in Rome, OOC sent four delegations; Mr. Tsushima, President; Mr. Takeda, Vice-president; Mr. Tabata, Secretary-general and Mr. Hirasawa, a member of the General Affairs Sub Committee.

The following subjects were proposed and reported on at the session.

(1) The period of the Games it was suggested would be sixteen days starting on the 23rd of May and ending on the 7th of June.

(2) The Japanese delegation strongly supported the proposal of the International Judo Federation that Judo be added to the sports events of the Games of the XVIII Olympiad.

(3) It was proposed that the demonstration sports would be Kendo and Baseball.

(4) The delegates explained the conditions and programme of the preparations for the Games.

After discussion, the IOC requested the Japanese delegation to submit a further proposal at the next IOC General Session on the precise timing of the Games.

As a result of a vote taken on that proposal, (subject (2) above), Judo was adopted with the overwhelming majority of 39:2 and thus the number of sports to be held at the Tokyo Games was increased to twenty-two.

An amendment of Olympic Charter was made as follows:

The rights to report the Games on Television which has been subjected to the IOC would be transferred to the Organizing Committee at the time of the Games, and the IOC would receive a fixed payment from the Organizing Committee. It was further decided that the amount which Tokyo Olympic Organizing Committee would pay to the IOC on this occasion would be US\$130,000.

At this executive board, the number of sports events to be held at the Tokyo Olympic Games was stipulated as being a maximum of eighteen.

Dec. 22: At the 14th meeting of the Organizing Com-

mittee, Mr. Fujita, a member of Committee and Director General of the Prime Minister's Office reported that the Tokyo Olympic Preparatory Council of the Government had decided to initiate a negotiation with the U.S. Forces Authorities for the return of the required area of the "US Forces' Camp Drake" in Asaka and Washington Heights in compliance with a request from this Organizing Committee. Mr. Takaishi, Chairman of the Sports events sub-committee, reported that the number of sports to be included in the Tokyo Games had been decided as follows and the Committee unanimously approved this resolution.

Athletics, Rowing, Basket-ball, Boxing, Cycling, Fencing, Foot-ball, Gymnastics, Swimming & Diving, Equestrian Sports, Shooting, Volleyball, Water-polo, Yachting, Judo, Weight-Lifting, Hockey and Wrestling.

1961

June 19-21: At the 58th IOC General Session in Athens, Dr. Azuma and Mr. Takaishi attended the session. This Organizing Committee sent Mr. Takeda, Vice-president; Mr. Tabata, Secretary-general; and Mr. Hirasawa, a member of the General Affairs Sub-committee. They proposed as follows:

(1) The number of sports events proposed numbered eighteen sports as decided at the 14th meeting of the Organizing Committee.

(2) That the Olympic Games period be for fifteen days from the 11th to 25th of October.

As to the number of sports events concerning (1), it was decided that a vote would be taken on each of the twenty-two sports events and that only those which had shown a majority would be included. This voting included Canoeing and Modern Pentathlon in the programme, so that twenty sports were to appear in the Tokyo Games. Sports of Archery and Handball were omitted.

A decision was made as to the period of the Games as was proposed by the Japanese delegation. It was decided however that the day following the opening ceremony would have no competitions and Japanese officials requested that they be allowed some latitude in working out a suitable schedule having regard to the increased number of sports events to be programmed and this request was approved.

June 30: At the 22nd meeting of the Organizing Committee, it was decided that twenty events would be held at the Tokyo Games which included Canoeing and Modern Pentathlon, and to devote every effort for the preparation and operation of the Tokyo Olympic Games.

July 1: Reorganization from an unregistered organization with no legal status to a legal entity (a juridical foundation), was approved by the Minister of Education of the Japanese Government.

Oct. 1: The Office of the Organizing Committee was moved to the site of the former Akasaka Detached Palace at 1, 1-chome, Akasaka, Minato-ku, Tokyo.

Oct. 23: At the 25th Meeting of the Organizing Committee, the decision relating to the site for the Olympic Village and the land location for the National Indoor Gymnasium to be constructed, was made as follows:

(1) The site for the Olympic Village would

be the area know as Washington Heights instead of the "U.S. Forces' Camp Drake" in Asaka in view of the various problems which presented themselves.

(2) A portion of the area (about 181,500 square metres) in the Washington Heights would be the land site for the construction of the National Indoor Gymnasium which would include the venues of sports of swimming and basket-ball.

(3) No permanent structures in principle would be built for the Olympic Village and the existing facilities would be utilized whenever possible to the extent that this was feasible.

(4) Request for road maintenance of the area surrounding Washington Heights should be made to the authorities concerned.

(5) The principle for the Toda Rowing Course would not be changed.

1962

Jan. 19: Mr. Seiichiro YASUI, Vice-president of the Organizing Committee, passed away deepest sympathy was expressed by the Committee.

Feb. 27: The construction work to increase the seating capacity of 55,000 to that of 75,000 was started with a budget of ¥1,200,000,000 (US\$3,333,333).

March 28: At the 27th Meeting of the Organizing Committee the following decisions were made.

(1) A total budget of ¥427,290,000 (US\$1,157,594) was approved for the Olympic Games for the Japanese fiscal year 1962.

(2) Structural expansion of the Secretariat was approved on a wider scale. This secretariat consisting of five divisions (Administration, Finance, Public Information, Sports Technique and Facilities), and a Disbursement Section, was reorganized to have nine divisions and two sections, adding a Planning Section, and the Foreign Affairs, Ticket, Transportation and Communications and Olympic Village Division.

(3) A World Youth Camp would take place at the time of the Tokyo Olympic Games.

May 28: At the 29th Meeting of the Organizing Committee, the following decisions were made:

(1) Resolved unanimously to enquire if H.M. Emperor of Japan would be graciously pleased to act as Patron of the Games.

(2) Decided that the Marathon course would start from the National Stadium and run to Tobita-kyu (turning point) by way of Shinjuku 3-chome and Koshu Kaido Highway and return over the same course.

(3) A Tokyo International Sports Meet would be held during the period October 11 through October 16 in 1963.

(4) Decided that a portion of the work function at the time of the Games would be entrusted to the IBM, Inc.

June 5-7: The 59th IOC General Session was held in Moscow, Mr. Tsushima, President, Mr. Tabata, Secretary-general, Mr. Hirasawa, a member of General Affairs Committee and other delegates were sent to this session, during which proposals and reports were presented as follows:

(1) Reported that H.M. Emperor of Japan would be graciously pleased to act as Patron of the Games.

(2) As for the period of the Games, the Organizing Committee proposed a sixteen-day period, that is, to hold the opening ceremony

- on the 9th October, with no games on 10th October, and with the first day of the competition on 11th October, and the closing ceremony on the 24th of October.
- (3) Proposed that within the limit of sixteen teams, both men's and women's volleyball games would be conducted.
- (4) Explained and reported on the progress of the preparations for the rules and regulations, sports facilities, Olympic Village and Press House, etc.
- After deliberation, the resolution which had passed the Athens Session calling for a holiday after the opening ceremonies was rescinded, and it was formally decided that the period of the Tokyo Olympic Games be fifteen days. Concerning the women's Volleyball, the participation of ten men's teams and six women's teams was approved and the decision was to apply only to the Tokyo Olympic Games providing the limit of sixteen teams would not be changed. At the time of the Games, an International Congress of Sport Sciences and a World Youth Camp would be conducted providing it will bring no problem to the Games and under the control of the authorized executive organization.
- June 29:** At the 30th Meeting of the Organizing Committee the followings were decided.
- (1) The final decision on the point of which period (9–23 October or 10–24 October) was reached, and the Games were officially scheduled to take place from the 10th to 24th of October.
- (2) Decided to make a request to the Japanese Defence Agency in which necessary support of the operation and personnel, equipment would be provided.
- The 4th Asian Games were held in Djakarta. The Organizing Committee send a delegation for the purpose of coordinating the overseas torch relay, publicizing the Tokyo Olympic Games and studying the things connected to Olympics.
- Oct. 3:** Mr. Juichi TSUSHIMA and Mr. Masaji TABATA, President and Secretary-general respectively, of the Organizing Committee, resigned but remained as members of the Organizing Committee.
- Oct. 15:** Vice-president TAKEDA assumed the Presidency of the Japanese Olympic Committee.
- Nov. 2:** At the 34th Meeting, the Organizing Committee approved the following motion.
- Mr. Shigeru YOSANO be given a seat on the Organizing Committee. His appointment as Secretary-general was approved unanimously.
- Nov. 22:** An Olympic Fanfare which was selected from submissions from the public.
- 1963**
- Feb. 1:** The construction of the National Indoor Gymnasium was started with a budget of about ¥250,000,000. (US\$694,444).
- Feb. 7:** At the 38th Meeting, the Organizing Committee commissioned Mr. Daigoro YASUKAWA to sit on the Committee, and unanimously elected him President of the Committee.
- Feb. 7–8:** IOC Executive Board was held in Lausanne. Mr. Yosano, Secretary-general of the Organizing Committee attended this Session. In this Session it was decided that the invitation to be sent to Indonesia to participate in the Tokyo Olympic Games be withheld.
- Feb. 13:** Mr. Sukarno, President of Indonesia, declared that Indonesia would withdraw from the IOC in every connection and separately organize a separate Games body.
- May 29:** The 1st Meeting of the Special Committee for the International Congress of the Sport Sciences was held.
- June 5:** IOC Executive Board was held in IOC Headquarters, Dr. Azuma, a member of Executive Board of IOC, and Mr. Yosano, Secretary-general from the Organizing Committee attended.
- At this meeting Dr. Azuma initially conveyed the feeling of Indonesia to the IOC that Indonesia would like to participate in the Tokyo Games. This however must be under the favourable conditions which will be able to satisfy by both Indonesia NOC and IOC.
- June 18:** At the 43rd Meeting, the Organizing Committee commissioned Mr. Shigeki TASHIRO to sit on the Committee and unanimously elected Messrs. Ryotaro AZUMA, Tsuneyoshi TAKEDA and Shigeki TASHIRO as Vice-presidents.
- June 30:** Alternation and modification work of National Stadium completed.
- July 1:** The construction work of the Press House started.
- Oct. 11–16:** The Tokyo International Sports Week took place in Tokyo.
- Oct. 17–20:** The 60th IOC General Session was held in Baden-Baden.
- Messrs. Azuma and Takaishi, IOC members, attended.
- The Organizing Committee sent Mr. Takeda, Vice-president; and Mr. Yosano, Secretary-general; to explain and report on the progress of the preparations for the Tokyo Olympic Games. The following motions were decided.
- (1) Confirmed that West and East Germany will combine their teams to one and will participate to the Tokyo Games.
- (2) Approved that Korea and North Korea will send their own delegations separately to the Games.
- (3) Decided that Taiwan will participate under the placard named Taiwan. However, athletes from Taiwan will be authorized to wear the initials of the Republic of China.
- (4) Regarding Indonesia participation, it was decided that if the National Olympic Committee of Indonesian would express their intention to strictly comply with the Olympic Rules and Regulations, the rescinding of Indonesia's disqualification for the participation to the Tokyo Games would be entrusted to the executive board of IOC, and accordingly to place on record a desire that Indonesia will participate in the Tokyo Games.
- Nov. 10–20:** GANEFO was held in Djakarta, Indonesia.
- 1964**
- Jan. 14:** Tokyo Olympic Eiga Kyokai (Olympic Documentary Film Association) was activated.
- Jan. 25–28** The 61st General Session was held in Innsbruck.
- Dr. Azuma, a member of IOC, attended.
- The Organizing Committee sent Mr. Yosano, Secretary-general, to report on the progress of the preparations for the Tokyo Games. As that time he had made an observation and inspection visit to the 9th Olympic Winter Games which was being held at the same location.

- At this session, it was decided that IOC will send a notice in accordance with the previous resolution of IOC session to the South Africa NOC that invitation letter from this organizing committee for the Tokyo Olympic Games would be invalid.
- Jan. 30:** The Organizing Committee for the Tokyo Olympic World Youth Camp was established.
- June 26–27:** IOC Executive Board was held at IOC Headquarters in Lausanne Dr. Ryotaro AZUMA attended this meeting.
Mr. IWATA, Director of Foreign Affairs Division of the Organizing Committee was sent to this meeting. In this meeting, it was unanimously decided by Board members that disqualification of Indonesia to the Tokyo Olympics has been cleared.
- July 16:** The main part of the Secretariat of the Organizing Committee moved to the newly built Kishi Memorial Hall at Yoyogi, Shibuya-ku, Tokyo.
- July 23:** The construction work of the Komazawa Olympic Park where will be Olympic Games site was completed.
- Aug. 1:** The invitation for the Tokyo Games to the 118 NOC's had been completed.
- Aug. 14:** Depart of Torch Relay Delegation.
- Aug. 21:** Sacred Flame lighting ceremony held at Olympia, Greece. Torch Relay runner started from Olympia.
- Aug. 31:** The construction work of the National Indoor Gymnasium in Yoyogi completed.
- Sept. 7:** Torch Relay arrives at Okinawa.
- Sept. 9:** Torch Relay in Japan started from Kagoshima, Miyazaki and Chitose Air port.
- Sept. 11:** Mr. Yosano, Secretary-general, made a statement on the point of view of the Organizing Committee as to the situation that both International Amateur Athletic Union and International Swimming Federation would not approve the participation to the Tokyo Games of these athletes who participated in GANEFO.
- Sept. 15:** Village Opening Ceremony was held at both main and detached village.
- Sept. 17:** Mr. Yosano departed to London for the further coordination with International Athletic Union to attempt to affect a smooth settlement of the GANEFO problem.
- Sept. 20:** Opening Ceremony of Press House was held.
- Oct. 3–8:** International Congress of Sport Sciences opened.
- Oct. 6–9:** The 62nd IOC General Session was held in Tokyo.
- Oct. 9:** Indonesia and North Korea withdrew their entire teams from Tokyo in expressing their complaint against the decision made by International Amateur Federation and International Swimming Federation concerning those athletes who participated in GANEFO.
- Oct. 10:** The Opening Ceremony of the Tokyo Olympic Games was held and the 70th Anniversary of the IOC was celebrated.
- Oct. 21:** Karuizawa Olympic Village was closed.
- Oct. 24:** Closing Ceremony of the Tokyo Olympic Games was held.
- Oct. 27:** Oiso Olympic Village was closed.
- Nov. 4:** At the 67th Meeting of the Organizing Committee, the following motions were decided.
- (1) The operation of the Tokyo Olympic Games had been successfully concluded. This was attributed to the nation wide cooperation of the Japanese people and of course included the Olympic officials concerned.
 - (2) The names of all winners of the Tokyo Olympic Games would be engraved on the

wall of the main entrance of the National Stadium, in accordance with the stipulation of Olympic Charter.

- Nov. 5:** The Closing Ceremony for the Olympic Village (Yoyogi) was held.

1965

- Jan. 21:** The Olympic Fund Raising Association has resolved its disorganization having attained the purpose of its foundation. ¥800,000,000 (US\$2,222,222) out of ¥1,100,000,000 (US\$ 3,055,556) balance remained was contributed to the Sports Fund Promotion Association which was established for the purpose of promoting the Amateur Sports in Japan.
- March 10:** The Olympic official documentary film entitled as "Tokyo Olympic" was completed and a special premier screening was held in the presence of their majesties The Emperor and Empress and HRH Crown Prince and Princess, and Olympic Personnel and officials.
- March 20:** The public showing of the official Olympic film "Tokyo Olympic" in Japanese version was commenced.
- June 23:** The unveiling ceremony of the engraved names of winners for the Tokyo Olympic Games, and Olympic day Ceremony in 1965 was held.
- June 30:** At the 71st Meeting of the Organizing Committee, the following business took place.
- (1) Dissolution of the Organizing Committee now that it had completed its function.
 - (2) A supplementary budget in fiscal year 1965 was approved.
 - (3) Disposition of remained property.
 - (4) Partial amendment for the Contribution regulation was approved.
 - (5) Nomination, appointment, election, designation and assignment of the liquidator members.

Note: The official Japanese language edition of the Official Report of the Tokyo Olympic Games was published on July 1966, and included full chronological tables of events. The compilation of English and French editions has taken a further half-year period to complete.

Name list of all participating athletes of The Tokyo Olympic Games

Liste des Noms de tous les athlètes participant aux Jeux Olympiques de Tokyo

NAME NOM	NO. NO.	SEX SEXE	HEIGHT HAUTEUR	WEIGHT POIDS	DATE OF BIRTH DATE DE NAISSANCE	EVENT EPREUVE
AFGHANISTAN AFGHANISTAN						
Anwary, Mohammed Daoud		M	.	.		Wrestling Lutte Free S.-Bantam
Askar, Faiz Mohammed		M	.	.		" Free S.-Fly
Djan, Djan Aka		M	.	.		" Free S.-Light
Ebrahimi, Mohammed E.		M	.	.		" Free S.-Feather
Noor, Nourullah		M	.	.		" Greco R.-Bantam
Said, Wahidullah		M	.	.		" Greco R.-Light
Sayed, Nour Aka		M	.	.		" Greco R.-Feather
Shakar, Shakar Khan		M	.	.		" Free S.-Welter
ALGERIA ALGERIE						
Lazhari, Mohamed	191	M	176.0	68.0	'38 • 4 • 28	Gymnastics Gymnastique
ARGENTINA ARGENTINE						
Buongiorno, Marta	1	F	170.0	58.0	'44 • 3 • 29	Athletics Athlétisme 4X100m
Dyrzka, Emilia E.L.	6	F	.	.		" 4X100m
Dyrzka, Juan Carlos Pablo	1	M	180.0	75.0	'41 • 3 • 24	" 400m, 110m, 400m Hurdles
Farina, Evelia Mabel	5	F	175.0	66.0	'41 • 12 • 7	" 4X100m, Long Jump
Formeiro, Maria Margarita	3	F	175.0	67.0	'44 • 12 • 31	" 100m, 4X100m
Kaufmanas, Alicia Adela	4	F	180.0	73.0	'40 • 12 • 20	" 4X100m, Long Jump
Ritchie, Susana Isabel	2	F	170.0	56.0	'44 • 12 • 10	" 200m, 4X100m
Suarez, Osvaldo Roberto	2	M	175.0	70.0	'34 • 3 • 17	" Marathon
Demiddi, Alberto		M	178.0	82.0	'44 • 4 • 11	Rowing Aviron Single Sculls
Duran, Ricardo		M	.	.		" Pair, Without Cox
Ensunza, Atilio		M	186.0	86.0	'37 • 7 • 7	" Four, Without Cox
Gomez, Juan Carlos		M	179.0	80.0	'32 • 5 • 9	" Double Sculls
Iannuzzi, Juan Alberto		M	186.0	85.0	'41 • 7 • 3	" Four, Without Cox
Lier, Juan Pedro		M	180.0	84.0	'38 • 12 • 24	" Pair, With Cox
Meana, Jorge Manuel		M	182.0	82.0	'38 • 12 • 27	" Four, Without Cox
Montaldo, Carlos Rodolfo		M				" Pair, Four, Without Cox
Robert, Mario Artemio		M				" Reserve, Cox
Robledo, Jose Maria		M	180.0	86.0	'39 • 7 • 7	" Double Sculls
Rompani, Oscar Carlos A.		M	158.0	82.0	'04 • 6 • 8	" Pair, With Cox
Rossi, Natalio Pablo		M	178.0	83.0	'34 • 2 • 22	" Pair, With Cox
Zanassi, Juan Francisco		M	185.0	85.0	'47 • 2 • 19	" Four, Without Cox
Aguilar, Juae	8	M	174.0	75.0	'43 • 5 • 15	Boxing Boxe Middle
Almaraz, Abel Cesar	2	M	152.0	54.0	'41 • 11 • 23	" Bantam
Amaya, Roberto Oscar	5	M	182.0	63.5	'43 • 9 • 12	" L. Welter
Chirino, Jose Roberto	7	M	171.0	71.0	'44 • 9 • 2	" L. Middle
Gargiulo, Rafael Luis	9	M	181.0	81.0	'36 • 10 • 24	" L. Heavy
Lovell, Santiago Alberto	10	M	186.0	88.0	'42 • 1 • 19	" Heavy
Martinez, Hugo Omar	3	M	169.0	57.0	'42 • 10 • 22	" Feather
Pace, Hector Jorge	4	M	169.0	60.0	'44 • 7 • 22	" Light
Pereyar, Felipe Mario	6	M	167.0	66.0	'42 • 9 • 22	" Welter
Romo, Luis	1	M	162.0	50.0	'44 • 8 • 19	" Fly
Acosta, Hector	1	M	171.0	74.0	'33 • 9 • 12	Cycling Cyclisme Road Ind., Team T. T.
Alvarez, Carlos	1	M	166.0	66.0	'41 • 7 • 19	" Team Pursuit
Breppe, Roberto Florencio	2	M	168.0	70.0	'41 • 2 • 4	" Road Ind., Team T. T.
Contreras, Ernesto	2	M	180.0	78.0	'37 • 7 • 19	" Ind. Team Pursuit
Delmastro, Delmo	3	M	168.0	70.0	'36 • 8 • 15	" Road Ind., Team T. T.
Garcia, Oscar	6	M	166.0	65.0	'41 • 9 • 13	" Scratch Sprint
Merlos, Juan Alberto	3	M	165.0	66.0	'44 • 12 • 15	" Team Pursuit
Placanica, Ruben	4	M	167.0	70.0	'43 • 7 • 27	" Road Team T. T.
Trillo, Alberto	4	M	167.0	66.0	'39 • 3 • 19	" Team Pursuit
Vazquez, Carlos Alberto	5	M	179.0	78.0	'34 • 2 • 13	" 1000m T. T., Scratch Sprint
Bisellach, Adolfo Gabriel	5	M	176.0	68.0	'42 • 5 • 13	Fencing Escrime Foil Ind., Epee Team
Casco, Zelmar Roberto	8	M	176.0	75.0	'26 • 7 • 30	" Epee Ind., Team
Frecia, Juan Carlos	10	M	174.0	74.0	'30 • 7 • 9	" Sabre Ind., Team
Galimi, Felix Domingo	4	M	180.0	90.0	'21 • 1 • 1	" Sabre Ind., Foil, Epee Team
Gonzalez Aldalur, R.A.	9	M	175.0	80.0	'20 • 4 • 29	" Sabre Ind., Team

NAME NOM	NO. NO.	SEX SEXE	HEIGHT HAUTEUR	WEIGHT POIDS	DATE OF BIRTH DATE DE NAISSANCE	EVENT EPREUVE	
Lanteri, Alberto Raul	6	M	170.0	68.0	'38 • 1 • 11	Fencing Escrime	Sabre Ind., Foil, Sabre Team
Nannini, Oriando Hipolito	2	M	172.0	74.0	'37 • 6 • 12	"	Foil Ind., Team
Romano, Maria Esther H	1	F	160.0	58.0	'31 • 11 • 28	"	Foil Ind.
Serp, Francisco Basilio	7	M	180.0	80.0	'30 • 4 • 19	"	Epee Ind., Team
Taboada, Jesus F.Z.	3	M	190.0	88.0	'40 • 7 • 12	"	Foil, Epee Ind., Team
Velazquez, Julian	11	M	167.0	72.0	'20 • 12 • 7	"	Sabre Ind.
Bertolotti, Andres Arturo	2	M	175.0	75.0	'43 • 9 • 1	Football	
Brandan, Francisco E.	15	M	182.0	78.0	'40 • 5 • 8	"	
Bulla, Carlos Alberto	9	M	182.0	65.0	'43 • 10 • 6	"	
Cabrera, Antonio Roberto	16	M	166.0	70.0	'43 • 10 • 17	"	
Cejas, Agustin Mario	1	M	185.0	80.0	'45 • 3 • 22	"	
Dominguez, Juan Carlos	18	M	169.0	71.0	'43 • 11 • 3	"	
Malleo, Jose	8	M	165.0	57.0	'44 • 1 • 29	"	
Manfredi, Nestor	10	M	168.0	70.0	'42 • 8 • 22	"	
Marin, Jose Miguel	12	M	185.0	78.0	'43 • 5 • 15	"	
Morales, Horacio Oscar	4	M	182.0	77.0	'43 • 6 • 27	"	
Mori, Miguel Angel	5	M	168.0	61.0	'43 • 5 • 17	"	
Ochoa, Hector Osvaldo	11	M	166.0	60.0	'42 • 7 • 5	"	
Pazos, Emilio Antonio	14	M	175.0	72.0	'45 • 7 • 24	"	
Perez, Ricardo Ramon	7	M	170.0	69.0	'44 • 8 • 23	"	
Perfumo, Roberto Alfredo	6	M	180.0	75.0	'42 • 10 • 3	"	
Risso, Juan Nazareno	17	M	168.0	70.0	'42 • 9 • 3	"	
Sconfianza, Juan Carlos	13	M	179.0	72.0	'43 • 7 • 13	"	
Sesana, Otto Norberto	3	M	175.0	76.0	'43 • 7 • 16	"	
Tojo, Miguel Angel	19	M	179.0	70.0	'43 • 7 • 9	"	
Pizzini, Carlos Alberto	195	M	175.0	75.0	'41 • 11 • 25	Gymnastics Gymnastique	
Eguiguren, Martin Jose	99	M	182.0	82.5	'41 • 1 • 15	Weight-Lifting Haltérophilie	L. Heavy
Selvetti, Humberto	144	M	180.0	139.2	'32 • 3 • 31	"	Heavy
Casella Michel Angel		M	.	90.0	'40 • 2 • 15	Judo	Heavy Weight
Karpencopf, Oscar Hugo		M	177.0	67.0	'44 • 5 • 10	"	Light Weight
Perez, Rodolfo		M	174.0	78.0	'45 • 1 • 6	"	Middle Weight
Graffigna, Julio Ricardo		M	171.0	78.0	'31 • 7 • 9	Wrestling Lutte	Free S.-Welter
Leibovich, Ruben		M	157.0	57.0	'34 • 4 • 25	"	Free S.-Bantam
Romero, Raul Alberto		M	169.0	63.0	'35 • 3 • 11	"	Free S.-Feather
Vario, Carlos Alberto		M	168.0	70.0	'47 • 10 • 17	"	Free S.-Light
Bourdillon, Alfredo		M	187.0	89.0	'43 • 3 • 13	Swimming and Diving Natation et Plongeoins	4X100m Medley
Diz Ezepeleta, Pedro		M	178.0	73.0	'43 • 7 • 15	"	200m Back, 4X100m Medley
Morello, Ricardo		M	185.0	85.0	'43 • 7 • 6	"	1500m, Free 4X100m Medley
Navarro, Miguel Angel		M	175.0	73.0	'41 • 10 • 12	"	200m Breast, 4X100m Medley
Nicolao, Luis Alberto		M	186.0	84.0	'44 • 6 • 28	"	100m, 400m Free 200m Butterfly, 4X100m Medley
Peper, Susana Norma		F	183.0	67.0	'46 • 2 • 26	"	200m Breast, 100m Back
Van Der Maath, Carlos		M	187.0	86.0	'46 • 5 • 24	"	100m, 400m Free, 200m Back, 4X100m Medley
Arrambide, Hugo Miguel		M	176.0	72.0	'27 • 9 • 25	Equestrian Sports Sport Equestre	Jumping Grand Prix
Canaves, Jorge Antonio		M	182.0	82.0	'22 • 9 • 6	"	Jumping Grand Prix
D'Alessandri, F. Obdulio		M	172.0	70.0	'30 • 6 • 21	"	Dressage Grand Prix
Delia, Carlos Cesar		M	175.0	70.0	'23 • 1 • 24	"	Jumping Grand Prix
Flores, Elvio Jose		M	173.0	67.0	'39 • 3 • 7	"	Three-Day Event
Gesualdi, Juan Carlos		M	172.0	65.0	'29 • 6 • 30	"	Three-Day Event
Henry, Julio Efrain		M	179.0	80.0	'33 • 3 • 11	"	Three-Day Event
Llambi, Iorce Bartolome		M	175.0	71.0	'39 • 3 • 7	"	Jumping Grand Prix
Moratorio, Carlos Alberto		M	173.0	67.0	'29 • 11 • 10	"	Three-Day Event
Armella, Eduardo F.	100	M	165.0	78.0	'28 • 6 • 20	Shooting Tir	Small Bore-3 P.
Aspitia, Humberto D.V.	103	M	173.0	75.0	'28 • 12 • 12	"	Free Pistol
Fernandez, Manuel Jose	105	M	181.0	105.0	'27 • 6 • 10	"	Rapid Fire Pistol
Lopez, Melchor J.	101	M	170.0	80.0	'13 • 1 • 7	"	Small Bore-Prone
Martini, Juan Angel A.	29	M	182.0	102.0	'15 • 12 • 28	"	Clay Pigeon
Nassiff, Cirilo	102	M	180.0	85.0	'05 • 11 • 4	"	Small Bore-Prone
Oxoby, Juan Carlos	104	M	176.0	82.0	'31 • 12 • 17	"	Rapid Fire Pistol
Passera, Jose	30	M	176.0	76.0	'16 • 2 • 21	"	Clay Pigeon
Boneo, Ricardo Manuel		M	172.0	72.0	'30 • 12 • 17	Yachting	Finn

NAME NOM	NO. NO.	SEX SEXE	HEIGHT HAUTEUR	WEIGHT POIDS	DATE OF BIRTH DATE DE NAISSANCE	EVENT EPREUVE	
Calegaris, Hector		M	173.0	76.0	'15 • 6 • 27	Yachting	Reserve
Del Rio, Jorge Alberto		M	178.0	90.0	'18 • 10 • 26	"	Dragon
Pekelharing, Arnolde		F	183.0	74.0	'36 • 7 • 1	"	Star
Rivademar, Rodolfo R.		M	158.0	54.0	'19 • 10 • 27	"	Dragon
Salas Chaves, Jorge A.		M	174.0	74.0	'14 • 6 • 17	"	Dragon
Sieburger, Roberto G.		M	183.0	80.0	'17 • 2 • 26	"	Star
AUSTRALIA							AUSTRALIE
Allsopp, Edward James	26	M	177.0	66.0	'26 • 8 • 15	Athletics Athlétisme	50km Road Walk
Amoore, Judith Florence	11	F	159.0	56.0	'40 • 6 • 25	"	400m
Bennett, Joyce Elaine	7	F	169.0	64.0	'45 • 5 • 11	"	200m, 4X100m
Bigby, Eric James	6	M	185.0	80.0	'40 • 3 • 6	"	200m, 4X100m
Black, Marilyn Mary	8	F	165.0	55.0	'44 • 5 • 20	"	100m, 200m, 4X100m
Blue, Anthony A.C.	10	M	180.0	65.0	'36 • 2 • 4	"	4X400m, 800m
Boase, Graham	20	M	179.0	75.0	'41 • 10 • 12	"	Triple Jump
Bowering, Dianne Marie	9	F	158.0	49.0	'43 • 10 • 9	"	100m, 4X100m
Brown, Michele Mary	15	F	171.0	55.0	'39 • 7 • 3	"	High Jump
Burvill, Margaret Ann	10	F	166.0	54.0	'41 • 10 • 2	"	100m, 200m, 4X100m
Clarke, Ronald William	12	M	183.0	74.0	'37 • 2 • 21	"	5000m, 10000m, Marathon
Cook, Anthony	13	M	183.0	68.0	'36 • 9 • 18	"	5000 m, 10000 m, Marathon
Crawford, Ronald John	23	M	179.0	80.0	'36 • 3 • 26	"	20km, 50km Road Walk
Cuthbert, Betty	12	F	169.0	57.0	'38 • 4 • 20	"	400m, 4X100m
Earle, William Joheph	3	M	174.0	65.0	'41 • 3 • 4	"	100m, 4X100m
Eddy, Gary John	7	M	183.0	76.0	'45 • 3 • 25	"	400m, 4X400m
Freeman, Noel Frederick	24	M	.	.	'38 • 12 • 24	"	20km Road Walk
Frith, Helen Audrey Ray	17	F	179.0	66.0	'39 • 7 • 12	"	Long Jump, Pentathlon
Gardiner, Robert Charles	25	M	169.0	60.0	'36 • 3 • 22	"	20km, 50km Road Walk
Holdsworth, Gary Alfred	4	M	179.0	77.0	'41 • 8 • 1	"	100m, 200m, 4X100m
Kilborn, Pamela	14	F	159.0	52.0	'39 • 8 • 12	"	80m Hurdles, 4X100m, Long Jump
Knoke, Gary James	14	M	190.0	76.0	'42 • 2 • 5	"	400m Hurdles, 4X400m
Lay, Robert William	5	M	170.0	65.0	'44 • 3 • 20	"	100m, 200m, 4X100m
Pazera, Anna	18	F	161.0	60.0	'36 • 11 • 25	"	Javelin Throw
Peckham, Lawrence William	17	M	190.0	80.0	'44 • 12 • 4	"	High Jump
Roche, Kenneth James	8	M	188.0	84.0	'41 • 10 • 24	"	400m, 400m Hurdles, 4X400m
Ryan, Michael A.B.	15	M	177.0	70.0	'41 • 12 • 19	"	400m Hurdles, 4X400m
Selvey, Warwick Perrins	21	M	196.0	115.0	'39 • 12 • 3	"	Discus throw
Sneazwell, Anthony Howard	18	M	185.0	80.0	'42 • 10 • 4	"	High Jump
Thomas, Albert George	11	M	166.0	57.0	'35 • 2 • 8	"	1500m, 5000m
Tomlinson, Ian Ross	19	M	188.0	70.0	'36 • 2 • 27	"	Long Jump, Triple Jump
Vagg, Robert Andrew	22	M	173.0	62.0	'40 • 2 • 2	"	Marathon
Vassella, Peter Francis	9	M	175.0	69.0	'41 • 1 • 4	"	400m, 4X100m, 4X400m
Vincent, Trevor Anthony	16	M	174.0	64.0	'38 • 4 • 27	"	3000m S. C.
Willis, Dixie Isobel	13	F	168.0	57.0	'41 • 11 • 13	"	800m
Woodhouse, Robyn	16	F	174.0	60.0	'43 • 7 • 26	"	High Jump
Allan, Graeme Keith		M	188.0	85.9	'38 • 6 • 25	Rowing Aviron	Four, With Cox
Boykett, David Hebbert		M	185.4	85.9	'34 • 8 • 19	"	Eight, With Cox
Campbell, John Alexander		M	188.0	90.9	'42 • 9 • 2	"	Four, With Cox
Davies, Terence Rodney		M	182.9	89.1	'33 • 10 • 18	"	Eight, With Cox
Duval, Alfred W.		M	190.5	85.9	'41 • 7 • 1	"	Four, With Cox
Edwards, Peter Frederick		M	188.0	85.9	'39 • 9 • 8	"	Single Sculls
Gammon, Wayne Bruce		M	155.0	38.0	'50 • 7 • 2	"	Pair, With Cox
Garrard, Richard James		M	175.3	80.8	'43 • 7 • 26	"	Four, Without Cox
Gillon, Peter Laidlaw		M	189.2	87.3	'39 • 8 • 11	"	Four, Without Cox
Grover, Alan Geoffrey		M	.	.		"	Four, With Cox
Guest, Paul Marshall		M	191.8	89.1	'39 • 3 • 8	"	Eight, With Cox
Herford, Gary Seymour		M	182.9	85.9	'40 • 8 • 10	"	Four, With Cox
Lachal, Robert Paul		M	188.0	85.9	'43 • 1 • 11	"	Eight, With Cox
Lehman, Charles James		M	188.0	82.3	'41 • 4 • 27	"	Reserve, Oarsmen
Lodding, Neil Walter		M	182.9	82.7	'44 • 10 • 2	"	Pair, With Cox
McCall, Graeme Allstair		M	195.6	95.5	'37 • 12 • 30	"	Eight, With Cox

NAME NOM	NO. NO.	SEX SEXE	HEIGHT HAUTEUR	WEIGHT POIDS	DATE OF BIRTH DATE DE NAISSANCE	EVENT EPREUVE
Newcomb, Simon Harvey		M	188.0	80.8	'38 • 8 • 11	Rowing Aviron
Ninham, Roger Arthur		M	182.9	80.4	'42 • 1 • 17	"
Northam, Rodney Maxwell		M	188.0	89.1	'43 • 5 • 15	"
Pearce, Gary Malcolm		M	182.9	83.6	'44 • 2 • 27	"
Ramage, David Barton		M	182.9	85.9	'39 • 6 • 25	"
Richardson, Bruce Edward		M	177.8	80.4	'42 • 10 • 5	"
Shirlaw, Robert Alan		M	186.7	82.7	'43 • 4 • 9	"
Tomanovits, Martin G.J.F.		M	185.4	87.3	'40 • 10 • 15	"
Vear, Brian John		M	182.8	85.4	'37 • 1 • 15	"
Wade, Barclay John		M	180.3	82.7	'44 • 4 • 5	"
Walker, Anthony Michael		M	172.7	74.6	'39 • 11 • 19	"
Wickham, Kevin John		M	172.0	52.0	'39 • 7 • 21	"
Ahmatt, Michael H.G.		M	188.1	73.0	'42 • 11 • 30	Basket-Ball
Cole, Kenneth Frank	8	M	204.0	88.5	'43 • 10 • 15	"
Dancis, Mikelis Reinis	11	M	200.5	105.2	'39 • 9 • 10	"
Davie, Theodore L.S.	4	M	177.9	69.3	'40 • 2 • 15	"
Gardiner, John Neville	15	M	190.6	89.0	'43 • 3 • 3	"
Gaze, Lindsay John Cassor	14	M	184.2	76.2	'36 • 8 • 16	"
Hackwill, Brendon Alan	5	M	204.0	85.7	'42 • 5 • 9	"
Heard, John Alastair	6	M	198.1	73.0	'39 • 2 • 11	"
Hody, Laszlo	13	M	192.0	84.0	'34 • 7 • 10	"
Linde, Werner Rudolph	12	M	183.0	77.8	'44 • 10 • 13	"
Rodwell, Clifford Carl	10	M	202.6	89.0	'44 • 5 • 12	"
Wyatt, William George	7	M	184.2	82.6	'38 • 7 • 27	"
Barber, Anthony Kenneth	17	M	166.0	63.0	'39 • 11 • 25	Boxing Boxe
Blair, Adrian	14	M	166.0	62.0	'43 • 12 • 21	"
Booth, William Neal	12	M	165.0	52.0	'44 • 9 • 19	"
Bukowski, John Michael	18	M	180.0	75.0	'39 • 1 • 18	"
Casey, Frederick James	19	M	180.0	79.0	'42 • 2 • 10	"
Hope, Randall John	13	M	160.0	56.7	'43 • 4 • 4	"
McQueen, Athol Ferguson	20	M	196.0	82.0	'41 • 11 • 11	"
Norwood, Darryl Michael	11	M	165.1	50.0	'44 • 12 • 4	"
Roberts, Francis Rov	16	M	170.0	65.0	'43 • 3 • 5	"
Rossi, Julian Joe	15	M	170.0	63.5	'42 • 2 • 12	"
Buck, Margaret Elison	1	F	168.0	59.0	'40 • 12 • 10	Canoeing Canotage
Coles, Phillip Walter	2	M	173.0	69.0	'31 • 7 • 20	"
Green, Dennis Allan	3	M	178.0	75.0	'31 • 5 • 26	"
Howard, Norma Joan	4	F	158.0	52.0	'45 • 5 • 24	"
Jeffery, Gordan George	5	M	182.5	83.0	'36 • 5 • 20	"
Jurickskay, Vid.	6	M	173.0	67.0	'34 • 8 • 12	"
Mc Guire, Denis John	7	M	176.0	70.0	'39 • 6 • 6	"
Powell, Adrian Francis	8	M	170.0	67.0	'41 • 4 • 6	"
Stuart, Barry Kenneth	9	M	172.5	70.0	'34 • 4 • 4	"
Wagg, Lynette, Ann	10	F	164.0	54.0	'39 • 6 • 5	"
Wasmer, Fred	11	M	178.0	74.0	'38 • 8 • 7	"
Biard, Robert Alexander	8	M	184.0	78.0	'42 • 11 • 29	Cycling Cyclisme
Bilney, Raymond V.	4	M	173.0	67.0	'45 • 11 • 2	"
Brislin, Kevin Jamea	7	M	188.0	79.0	'42 • 11 • 26	"
Browne, Ian Sterry	11	M	185.0	86.0	'31 • 6 • 22	"
Browne, Victor George	9	M	185.0	79.0	'42 • 1 • 10	"
Harrison, Thomas	14	M	182.0	75.0	'42 • 5 • 13	"
Hine, Richard John	16	M	169.0	59.0	'39 • 12 • 11	"
Hollingsworth, Michael F.	6	M	170.0	67.0	'43 • 10 • 16	"
Humphreys, David Brian	5	M	178.0	74.0	'36 • 12 • 13	"
Johnson, Lewis Gordon	15	M	176.0	76.0	'46 • 8 • 1	"
Mc Creadie, Malcolm R.	7	M	180.0	78.0	'42 • 10 • 3	"
Paris, Richard Ian	13	M	174.0	76.0	'42 • 4 • 8	"
Perkins, Daryl William	12	M	175.0	76.0	'43 • 4 • 20	"
Vogels, Hendrikus A.M.	10	M	182.0	81.0	'42 • 11 • 1	"

NAME NOM	NO. NO.	SEX SEXE	HEIGHT HAUTEUR	WEIGHT POIDS	DATE OF BIRTH DATE DE NAISSANCE	EVENT EPREUVE	
Bowditch, Ian Walter John	24	M	186.0	86.0	'39 • 3 • 9	Fencing Escrime	Epee Team
Douglas, John Alan	20	M	170.0	66.0	'43 • 5 • 7	"	Foil Team
Hobby, Russ Keith	23	M	190.0	80.0	'33 • 1 • 22	"	Epee Ind., Team
Hopner, Janet Dorothea	12	F	157.0	58.0	'36 • 1 • 15	"	Foil Ind., Team
Humphreys, John Douglas	22	M	184.0	90.0	'32 • 3 • 15	"	Epee Men Ind., Team
Lund, Ivan Barnard	19	M	188.0	81.0	'29 • 5 • 13	"	Epee, Foil Ind., Team
Martonffy, Alexander	26	M	169.0	73.0	'19 • 5 • 7	"	Sabre Ind., Team
McCowage, Brian Patric	17	M	181.0	70.0	'34 • 5 • 20	"	Sabre, Foil Ind., Team
McKenzie, David Henry	18	M	179.0	68.0	'36 • 7 • 15	"	Foil Ind., Team
Redman, Jan	13	F	166.0	61.0	'32 • 2 • 21	"	Foil Ind., Team
Rizzuto, Paul Joseph	29	M	176.0	69.0	'36 • 9 • 14	"	Sabre Team
Sommerville, Henry James	28	M	170.0	70.0	"	"	Sabre Team
Terauds, Imants	25	M	174.0	66.0	'36 • 7 • 26	"	Epee Team
Tornallyay, Les	27	M	181.0	75.0	'31 • 8 • 14	"	Sabre Ind., Team
Tubier, Gerard	21	M	180.0	65.0	'38 • 10 • 26	"	Foil Team
Winter, Johanna	14	F	175.0	72.0	'42 • 5 • 21	"	Foil Ladies Ind., Team
Winter, Ulrike	15	F	169.0	71.0	'40 • 11 • 24	"	Foil Team
Winter, Walburga	16	F	171.0	59.0	'43 • 7 • 19	"	Foil Team
Bedford, Janice May	101	F	151.1	50.8	'45 • 5 • 15	Gymnastics Gymnastique	
Bond, Graham Francis	131	M	175.3	73.0	'37 • 5 • 6	"	
Buffham, Valerie Ivy	104	F	151.0	48.5	'43 • 6 • 28	"	
Cage, Barbara Anne	106	F	158.8	50.3	'41 • 9 • 16	"	
Cheales, Barry John	136	M	177.1	68.0	'43 • 2 • 7	"	
De Roo, Benjamin Mielke	135	M	160.0	63.5	'40 • 2 • 11	"	
Faulks, Marcus A.C.	132	M	174.0	63.5	'37 • 8 • 3	"	
Fletcher, Barbara Kay	102	F	158.4	50.8	'43 • 5 • 15	"	
Hancock, Lynnette Beverly	105	F	157.5	48.5	'48 • 1 • 15	"	
Maclennan, Douglas	134	M	172.7	63.5	'39 • 11 • 2	"	
Roberts, Valerie Lois	103	F	158.4	51.7	'38 • 7 • 10	"	
Trainer, Frederick Edward	133	M	182.9	78.0	'41 • 3 • 5	"	
Coffa, Salvatore	1	M	152.0	55.5	'36 • 1 • 15	Weight-Lifting Haltérophilie	Bantam
Hall, Graeme Lansell	125	M	176.0	88.0	'42 • 2 • 9	"	M. Heavy
Hay, Gerald	2	M	157.0	57.0	'46 • 10 • 9	"	Bantam
Haydar, Joseph	78	M	167.0	74.0	'38 • 11 • 18	"	Middle
Marguccio, Antonio	31	M	160.0	59.0	'40 • 5 • 24	"	Feather
Shannos, Arthur	145	M	175.0	118.0	'38 • 3 • 4	"	Heavy
Vakakis, George	100	M	172.0	81.0	'43 • 11 • 9	"	L. Heavy
Crossman, Mervyn	3	M	175.3	90.8	'35 • 4 • 6	Hockey	
Dearing, Paul	4	M	175.3	76.7	'42 • 3 • 2	"	
Evans, Raymond	5	M	175.3	74.8	'39 • 9 • 28	"	
Glencross, Brian	6	M	177.8	79.0	'41 • 5 • 1	"	
Hodder, Robin	7	M	170.2	65.4	'37 • 10 • 1	"	
Martin, Donald	10	M	175.3	73.1	'40 • 2 • 8	"	
McBryde, John	1	M	177.8	72.6	'39 • 3 • 9	"	
McCormack, John	8	M	175.3	73.1	'31 • 2 • 27	"	
McWatters, Donald	9	M	182.9	78.5	'41 • 1 • 23	"	
Morley, Charles	17	M	170.2	79.5	'16 • 5 • 3	"	
Nilan, Patrick	11	M	172.7	65.4	'41 • 6 • 30	"	
Pearce, Eric	12	M	180.3	77.2	'32 • 10 • 29	"	
Pearce, Julian	13	M	180.3	80.8	'37 • 4 • 15	"	
Piper, Desmond	2	M	175.3	69.9	'41 • 10 • 11	"	
Smart, Donald	14	M	173.7	71.7	'42 • 1 • 7	"	
Waters, Antony	16	M	175.3	73.1	'28 • 4 • 10	"	
Wood, Graham	15	M	172.7	70.8	'36 • 6 • 24	"	
Boronovskis, Theodore		M	183.0	104.0	'43 • 7 • 27	Judo	All Weights
Dalton, Brian		M	170.1	66.5	'35 • 7 • 5	"	Light Weight
Ford., Ronald Keith		M	175.3	67.2	'42 • 9 • 7	"	Light Weight
Paige, Peter Ranken		M	175.0	80.2	'39 • 3 • 1	"	Middle Weight
Boyle, John Martin		M	171.0	78.0	'34 • 11 • 1	Wrestling Lutte	Free S.-Welter

NAME NOM	NO. NO.	SEX SEXE	HEIGHT HAUTEUR	WEIGHT POIDS	DATE OF BIRTH DATE DE NAISSANCE	EVENT EPREUVE
Brown, Raymond Geoffrey		M	170.0	63.0	'43 • 2 • 16	Wrestling Lutte
Cacas, Donald		M	162.0	65.0	'30 • 7 • 10	"
Marsh, Sidney Reginald		M	170.0	72.0	'39 • 8 • 31	"
McAlary, Max		M	165.0	52.0	'29 • 12 • 20	"
McGrath, Kevin		M	191.0	57.0	'46 • 3 • 16	"
Raskovy, Istvan		M	182.0	87.0	'36 • 11 • 25	"
Williams, Hugh		M	177.0	94.0	'33 • 9 • 3	"
Alexander, A. Fleming		M	.	.		Swimming and Diving Natation et Plongeurs
Barnetson, Shristine P.		F	.	.		"
Bell, Lynette		F	.	.		"
Berry, Kevin John		M	.	.		"
Bradshaw, Robyn Jean		F	.	.		"
Buck, Terry William		M	.	.		"
Byrom, John Douglas		M	.	.		"
Cortis, Jane		F	.	.		"
Dayman, Marlene Anne		F	.	.		"
De Greenlaw, Gillian C.		F	.	.		"
Dickson, David Gavin		M	.	.		"
Doak, Peter John		M	.	.		"
Duncan, Nanette Mary		F	.	.		"
Fraser, Dawn		F	.	.		"
Herford, Kim		F	.	.		"
Hill, Brett Cecil Graeme		M	.	.		"
Knight, Susan Margaret		F	.	.		"
Konrads, John		M	.	.		"
Ling, Richard		M	.	.		"
McGill, Linda Carol		F	.	.		"
Murphy, Janice		F	.	.		"
Obrien, Ian		M	.	.		"
Oravainen, John V		M	.	.		"
Phegan, Russell		M	.	.		"
Phelps, Peter		M	.	.		"
Reynolds, Peter Askin		M	.	.		"
Ruygrok, Margueritha I.		F	.	.		"
Ryan, John		M	.	.		"
Stark, John		M	.	.		"
Thorn, Robyn		F	.	.		"
Tonkin, Peter James		M	.	.		"
Turner, Jan		F	.	.		"
Windle, Robert George		M	.	.		"
Wood, Allan		M	.	.		"
Woosley, Belinda		F	.	.		"
Macken, Peter Neville	5	M	175.0	70.0	'38 • 11 • 10	Modern Pentathlon Pentathlon Moderne
McMiken, Donald Fraser	6	M	171.0	68.0	'42 • 5 • 20	"
Mitchelson, Lloyd John	7	M	186.0	80.3	'39 • 7 • 23	"
Page, Duncan	8	M	175.0	76.0	'35 • 10 • 29	"
Bacon, Kevin Ashley		M	176.0	70.0	'32 • 3 • 20	Equestrian Sports Sport Equestre
Cobcroft, Brien W.B.		M	181.0	70.0	'34 • 10 • 11	"
Fahey, Thomas John		M	168.0	64.0	'43 • 8 • 27	"
Kelly, John Wilson		M	180.0	74.3	'25 • 7 • 10	"
Lavis, Neale John		M	174.0	67.0	'30 • 6 • 11	"
Macintyre, Bridget Anne		F	169.0	58.0	'33 • 9 • 26	"
Roycroft, Barry Thomas		M	183.0	70.0	'44 • 5 • 2	"
Roycroft, James W.G.		M	188.0	77.0	'15 • 3 • 17	"
Coffey, Leslie Raymond	111	M	171.0	78.0	'36 • 9 • 9	Shooting Tir
Gonczol, Tibor	113	M	183.0	86.0	'33 • 1 • 19	"
Johnson, Rodney	110	M	175.0	83.0	'27 • 8 • 24	"
Kirkwood, James	109	M	183.0	88.9	'30 • 11 • 24	"
Murphy, John	107	M	174.0	73.0	'19 • 4 • 10	"

NAME NOM	NO. NO.	SEX SEXE	HEIGHT HAUTEUR	WEIGHT POIDS	DATE OF BIRTH DATE DE NAISSANCE	EVENT EPREUVE	
Papps, Michael Francis	112	M	165.0	64.0	'32 • 7 • 20	Shooting Tir	Rapid Fire Pistol
Rule, Norman	108	M	170.0	67.0	'28 • 1 • 8	"	Small Bore-Prone
Tolhurst, Donald Cecil	106	M	170.0	67.0	'29 • 6 • 24	"	Small Bore-3 P.
Barnes, Nicol		M	.	.		Water-Polo	
Hammond, Stanley R.A.		M	.	.		"	
Hoad, Thomas Henry		M	.	.		"	
McAtee, William Anthony		M	.	.		"	
Mills, Ian Alexander		M	.	.		"	
Nunn, Leslie Ernest		M	.	.		"	
Peirce, Edward John		M	.	.		"	
Phillips, William J. B.		M	.	.		"	
Samuel, Graeme Leslie		M	.	.		"	
Wiegard, Leon Albert		M	.	.		"	
Withers, Michael Rodney		M	.	.		"	
Coon, John Malcolm		M	177.8	67.6	'29 • 10 • 31	Yachting	Dragon
Dawe, John Gregory		M	174.0	64.4	'28 • 1 • 24	"	F. Dutchman
Drane, Graham Horace		M	180.3	72.6	'16 • 8 • 21	"	Dragon
Hardy, James Gilbert		M	189.2	85.7	'32 • 11 • 20	"	Reserve
Jenyns, Ronald Graeme		M	180.3	83.9	'36 • 2 • 25	"	Reserve
Manford, Frank Anthony		M	181.6	82.6	'31 • 11 • 15	"	Reserve
Northam, William Herbert		M	182.9	80.7	'05 • 9 • 28	"	5.5m
O'Donnell, Peter Joseph		M	182.9	88.9	'43 • 11 • 2	"	5.5m
Owens, Thomas Alfred		M	182.9	110.2	'38 • 7 • 10	"	Star
Quartermain, Ian Myron		M	170.2	81.6	'40 • 12 • 30	"	Dragon
Ryrie, Colin Stirling		M	189.2	84.8	'29 • 12 • 23	"	Finn
Sargeant, James F.R.		M	182.9	76.2	'36 • 3 • 17	"	5.5m
Visser, Martinus Wiendect		M	180.3	88.9	'24 • 12 • 28	"	Star
Winter, Ian Charles		M	186.7	82.6	'41 • 3 • 31	"	F. Dutchman
AUSTRIA							AUTRICHE
Aigner, Inge	19	F	170.0	62.0	'43 • 1 • 30	Athletics Athlétisme	100m, 200m, 80m Hurdles
Flegel, Ulla	20	F	172.0	61.5	'39 • 10 • 22	"	High Jump, Pentathlon
Haid, Helmut	29	M	180.0	70.0	'38 • 11 • 18	"	400m Hurdles
Klaban, Rudolf	27	M	170.0	60.0	'38 • 4 • 5	"	800 m
Soudek, Ernst	30	M	196.0	89.0	'40 • 9 • 30	"	Discus Throw
Sykora, Liesl	21	F	173.0	60.0	'41 • 3 • 27	"	High Jump
Thun, Heinrich	31	M	180.0	97.0	'38 • 9 • 1	"	Hammer Throw
Tulzer, Volker	28	M	177.0	70.0	'40 • 6 • 24	"	1500m
Ebner, Dieter		M	188.0	81.0	'40 • 6 • 26	Rowing Aviron	Four, Without Cox
Kloimstein, Josef		M	180.0	80.0	'29 • 11 • 1	"	Pair, With Cox
Krausbar, Manfred		M	186.0	78.0	'42 • 7 • 24	"	Four, Without Cox
Kuttelwascher, Horst		M	186.0	82.0	'37 • 10 • 6	"	Four, Without Cox
Losert, Dieter		M	184.0	82.0	'40 • 11 • 1	"	Four, Without Cox
Sageder, Alfred		M	181.0	79.0	'33 • 9 • 29	"	Pair, With Cox
Salzbacher, Peter		M	164.0	50.0	'46 • 5 • 29	"	Pair, With Cox
Frauenlob, Franz	23	M	172.0	75.0	'39 • 11 • 8	Boxing Boxe	Middle
Konig, Rupert	22	M	174.0	64.0	'37 • 4 • 3	"	L.-Welter
Weiss, Peter	21	M	169.0	56.5	'38 • 12 • 16	"	Feather
Heubusch, Kurt	12	M	186.0	75.0	'41 • 8 • 4	Canoeing Canotage	Kayak 2, 4
Lindlgruber, Kurt	13	M	175.0	70.0	'34 • 11 • 1	"	Kayak 4
Pfaff, Gunther	14	M	180.0	72.0	'39 • 8 • 12	"	Kayak 1, 2, 4
Severa, Ernst	15	M	167.0	58.0	'34 • 9 • 21	"	Kayak 4
Spitz, Anneliese	16	F	170.0	68.0	'41 • 11 • 24	"	Kayak 1
Becher, Martin	31	M	187.0	75.0	'44 • 10 • 21	Fencing Escrime	Foil, Epee Ind., Team
Birnbaum, Udo	34	M	173.0	76.0	'37 • 2 • 8	"	Epee Team
Leyrer, Marcus	32	M	184.0	71.0	'29 • 4 • 13	"	Epee Ind., Team
Losert, Roland	30	M	185.0	70.0	'45 • 1 • 6	"	Foil, Epee Ind., Team
Polzhuber, Herbert	35	M	183.0	76.0	'38 • 6 • 24	"	Epee Ind., Team
Trost, Rudolf	33	M	187.0	83.0	'40 • 8 • 27	"	Epee Ind., Team
Parzer, Henriette	111	F	160.0	60.0	'43 • 8 • 28	Gymnastics Gymnastique	

NAME NOM	NO. NO.	SEX SEXE	HEIGHT HAUTEUR	WEIGHT POIDS	DATE OF BIRTH DATE DE NAISSANCE	EVENT EPREUVE	
Hastik, Gerhard	101	M	174.0	80.0	'39 • 6 • 1	Weight-Lifting Haltérophilie	L. Heavy
Herbst, Kurt	126	M	182.0	89.0	'40 • 12 • 22	"	M. Heavy
Querch, Udo	146	M	182.0	126.0	'41 • 6 • 16	"	Heavy
Redl, Alfred		M	179.0	79.0	'40 • 8 • 10	Judo	Middle Weight
Reisinger, Karl		M	167.0	68.0	'36 • 4 • 8	"	Light Weight
Zotter, Gerhard		M	169.0	68.0	'41 • 4 • 24	"	Light Weight
Eugen, Wiesberger		M	184.0	97.0	'33 • 12 • 30	Wrestling Lutte	Greco R.-L. Heavy
Franz, Berger		M	174.0	68.0	'40 • 1 • 24	"	Greco R.-Light
Helmut, Langle		M	174.0	78.0	'36 • 9 • 29	"	Greco R.-Welter
Johann, Marte		M	170.0	64.0	'35 • 5 • 28	"	Greco R.-Feather
Deckardt, Volker		M	181.0	81.0	'44 • 3 • 9	Swimming and Diving Natation et Plongeoins	200m Butterfly
Filippovits, Christine		F	165.0	69.0	'44 • 7 • 21	"	200m Breast
Kolli, Gert		M	179.0	75.0	'40 • 5 • 31	"	100m, 400m Free
Mrkwicka, Kurt		M	180.0	76.0	'37 • 7 • 16	"	Springboard, High Diving
Paukerl, Christine		F	172.0	70.0	'46 • 11 • 22	"	100 m Free
Pertmayr, Ingeborg		F	170.0	63.0	'47 • 4 • 7	"	Springboard, High Diving
Seitz, Ursula		F	163.0	55.0	'48 • 4 • 10	"	100m Back
Sindelar-Pachowsky, U.		F	158.0	50.0	'43 • 6 • 25	"	Springboard, High Diving
Suda, Friedel		M	175.0	64.0	'39 • 6 • 11	"	200m Back
Svoboda, Elisabeth		F	172.0	70.0	'42 • 10 • 7	"	Springboard, High Diving
Wieland, Gerhard		M	184.0	80.0	'44 • 8 • 27	"	100m Free, 200m Back
Birnbaum, Udo	9	M	173.0	67.0	'37 • 2 • 8	Modem Pentathlon Pentathlon Moderne	
Polzhuber, Herbert	10	M	183.0	76.0	'38 • 6 • 24	"	
Trost, Rudolf	11	M	187.0	83.0	'40 • 8 • 27	"	
Hammerer, Hubert	114	M	172.0	83.0	'25 • 9 • 10	Shooting Tir	Free Rifle, Small Bore-3 p., Prone
Meixner, Josef	9	M	171.0	90.0	'39 • 12 • 7	"	Clay Pigeon
Szapary, Ladislaus	8	M	190.0	87.0	'10 • 7 • 12	"	Clay Pigeon
Fischer, Werner		M	176.0	76.0	'40 • 11 • 9	Yachting	F. Dutchman
Geiger, Karl		M	168.0	66.0	'41 • 3 • 6	"	F. Dutchman
Raudaschl, Hubert		M	187.0	76.0	'42 • 8 • 26	"	Finn
BRITISH GUIANA		GUYANE-BRITANNIQUE					
Dias, Martin	15	M			'36 • 10 • 17	Weight-Lifting Haltérophilie	Bantam
BAHAMAS		BAHAMAS					
Collie, George Reginald	32	M	173.0	70.0	'41 • 12 • 21	Athletics Athlétisme	100m, 200m
Robinson, Thomas Augustus	33	M	180.0	82.0	'38 • 3 • 16	"	100m, 200m
Saunders, Hartley Cecil	34	M	183.0	80.0	'43 • 11 • 7	"	Triple Jump
Cooke, Cecil George		M	188.0	90.0	'23 • 5 • 31	Yachting	Star
Eardley, Robert Bradford		M	157.5	55.0	'44 • 1 • 12	"	Dragon
Kelly, Basil Trevor		M	182.0	95.0	'30 • 5 • 11	"	Dragon
Kelly, Godfrey Kenneth		M	180.0	55.0	'28 • 12 • 21	"	Dragon
Kelly, Maurice George		M	181.0	76.0	'23 • 10 • 2	"	Reserve
Knowles, Durward Randolph		M	179.0	59.0	'17 • 11 • 2	"	Star
Knowles, Percival Andrew		M	170.0	74.0	'30 • 11 • 8	"	5.5m
Ramsay, Leroy Faria		M	180.0	102.0	'12 • 9 • 28	"	5.5m
Symonette, Robert Hallam		M	190.5	90.0	'25 • 1 • 31	"	5.5m
BELGIUM		BELGIQUE					
Allonsius, Eugene	38	M	175.0	64.0	'37 • 12 • 12	Athletics Athlétisme	1500m, 5000m
Boekaerts, Paul	37	M	175.0	65.0	'39 • 4 • 15	"	800m
Clerckx, Henri	39	M	178.0	68.0	'36 • 8 • 31	"	5000m 10000m
Coppejans, Paul	43	M	183.0	72.0	'33 • 9 • 28	"	Pole Vault
Geerems, Wilfried	42	M	185.0	80.0	'41 • 7 • 14	"	400m Hurdles
Lambrechts, Joseph	36	M	176.0	69.0	'35 • 10 • 5	"	800m
Marien, Leopold	41	M	180.0	78.0	'34 • 3 • 22	"	110m Hurdles
Pennewaert, Jacques	35	M	184.0	76.0	'40 • 3 • 11	"	400m 800m
Roelants, Gaston	40	M	174.0	58.0	'37 • 2 • 5	"	5000m, 10000m, 3000m S. C.
Vandendriessche, Aurele	44	M	173.0	60.0	'32 • 7 • 4	"	Marathon
De Meulemeester, Michel		M	180.0	77.0	'43 • 5 • 21	Rowing Aviron	Double Sculls
Higny, Gerard		M	187.0	88.0	'31 • 8 • 20	"	Double Sculls
Roels, Rene	17	M	173.0	70.0	'37 • 9 • 3	Canoeing Canotage	Kayak 1, 2

NAME NOM	NO. NO.	SEX SEXE	HEIGHT HAUTEUR	WEIGHT POIDS	DATE OF BIRTH DATE DE NAISSANCE	EVENT EPREUVE
Verbrugge, Henri	18	M	175.0	75.0	'29 • 7 • 20	Canoeing Canotage Kayak 2
Boons, Jozef	8	M	.	.	'43 • 2 • 13	Cycling Cyclisme Ind. Road
De Neve, Roland	6	M	180.0	71.7	'44 • 2 • 19	" Road team T. T.
Godefroot, Walter	9	M	171.0	73.0	'43 • 7 • 2	" Ind. Road
Heuvelmans, Leopold	5	M	172.0	71.5	'45 • 3 • 24	" Road Team T. T.
Merckx, Eddy	10	M	182.0	74.0	'45 • 6 • 17	" Ind. Road
Sercu, Patrick	17	M	180.0	76.0	'44 • 6 • 27	" 1000m T. T., Scratch Sprint
Swerts, Roger	11	M	180.0	75.0	'42 • 12 • 28	" Ind. Road
Van De Rijse, Roland	7	M	179.0	71.0	'42 • 8 • 2	" Road Team T. T.
Van Loo, Herman	18	M	187.0	80.0	'45 • 1 • 14	" Ind. Pursuit
Van Vlierberghe, Albert	8	M	160.0	77.5	'42 • 3 • 18	" Road Team T. T.
Brasseur, Yves	37	M	183.0	83.0	'43 • 2 • 26	Fencing Escrime Sabre Ind.
Van Den Driessche, Rene	36	M	175.0	79.0	'28 • 8 • 14	" Epee Ind.
Grymonprez, Veronica	51	F	163.0	59.0	'44 • 1 • 17	Gymnastics Gymnastique
Reding, Serge	147	M	172.0	115.0	'35 • 10 • 29	Weight-Lifting Haltéophilie Heavy
Berger, Michel	1	M	176.0	79.0	'41 • 1 • 10	Hockey
Bernaert, Yves	6	M	184.0	75.0	'37 • 3 • 27	"
Buisset, Jean-marie	12	M	172.0	65.0	'38 • 8 • 21	"
Le Clerc, Jean-Louis	5	M	188.0	82.0	'40 • 1 • 19	"
Lorette, Franz	13	M	178.0	68.0	'35 • 6 • 15	"
Miserque, Guy	7	M	172.0	62.0	'45 • 7 • 16	"
Moussiaux, Daniel	3	M	183.0	73.0	'45 • 9 • 17	"
Muschs, Andre	9	M	175.0	74.0	'34 • 9 • 10	"
Muschs, Michel	14	M	180.0	78.0	'40 • 5 • 30	"
Ravinet, Claude	8	M	174.0	64.0	'43 • 3 • 24	"
Remy, Jacques	4	M	167.0	60.0	'36 • 2 • 5	"
Rens, Eredy	15	M	178.0	76.0	'36 • 12 • 25	"
Roersch, Jean-Louis	11	M	178.0	67.0	'36 • 10 • 8	"
Van Beuren, Eric	16	M	173.0	62.0	'42 • 7 • 5	"
Vanderstappen, Jacques	2	M	173.0	74.0	'30 • 9 • 1	"
Verhoeven, Guy	10	M	170.0	68.0	'38 • 3 • 18	"
Mewis, Joseph		M	163.0	70.0	'31 • 3 • 23	Wrestling Lutte Greco R.-Feather
Mewis, Maurice		M	155.0	53.0	'29 • 9 • 16	" Greco R.-Fly
Michiels, Albert		M	178.0	81.0	'31 • 6 • 29	" Greco R.-Welter
Simons, Francois		M	183.0	75.0	'46 • 10 • 25	Swimming and Diving Natation et Plongeoins 100 m Free
Verbauwen, Herman		M	183.0	75.0	'44 • 5 • 16	" 200m Back
Lafortune, Francois	115	M	174.0	66.0	'32 • 2 • 7	Shooting Tir Small Bore-3 P. Prone
Caufrier, Jacques		M	187.0	88.0	'42 • 2 • 15	Water Polo
D'Oosterlinck, Frank		M	192.0	92.0	'42 • 10 • 30	"
De Hesselle, Bruno		M	188.0	96.0	'41 • 9 • 9	"
De Vis, Karel		M	174.0	73.0	'37 • 12 • 29	"
De Wilde, Roger		M	178.0	92.0	'40 • 4 • 5	"
Dumont, Jose		M	175.0	79.0	'40 • 6 • 6	"
Laurent, Andre		M	181.0	79.0	'31 • 2 • 14	"
Pickers, Leon		M	186.0	85.0	'37 • 7 • 27	"
Stappers, Joseph		M	180.0	82.0	'42 • 6 • 13	"
Van Den Steen, Johan		M	183.0	88.0	'29 • 1 • 8	"
Van Reybroeck, Eric		M	179.0	70.0	'42 • 3 • 19	"
Nelis, Andre		M	195.0	94.0	'35 • 10 • 29	Yachting Finn
BERMUDA		BERMUDES				
Cooper, Edmund Kirkland		M	183.0	78.0	'32 • 7 • 28	Yachting Dragon
Cooper, Reginald Chapman		M	170.0	73.5	'21 • 11 • 13	" Reserve
Hooper, Jay Cameron		M	175.0	68.9	'43 • 12 • 30	" Finn
Leseur, John Clyde		M	173.0	63.5	'37 • 1 • 7	" Reserve
Simmons, Eugene Scott		M	175.0	71.7	'38 • 11 • 11	" Dragon
Soares, Conrad Paul		M	175.0	70.3	'39 • 4 • 22	" Dragon
BOLIVIA		BOLIVIE				
Garabito, Alberto	45	M	160.0	48.0	'36 • 2 • 5	Athletics Athlétisme Marathon
Montano, Alejo	46	M	164.0	59.0	'35 • 2 • 17	" Marathon

NAME NOM	NO. NO.	SEX SEXE	HEIGHT HAUTEUR	WEIGHT POIDS	DATE OF BIRTH DATE DE NAISSANCE	EVENT EPREUVE	
Inchauste, Fernando BRAZIL	19	M	184.0	84.0	'30 • 6 • 18	Canoeing Canotage	Kayak 1
BRESIL							
Dos Santos, Aida	22	F			'37 • 3 • 1	Athletics Athlétisme	High Jump
Bispo Dos Santos, Edson	11	M	195.0	86.0	'35 • 5 • 27	Basket-Ball	
De Souza, Carmo	9	M	189.0	86.0	'40 • 7 • 16	"	
De Toledo Machado, Sergio	14	M	190.0	78.0	'45 • 2 • 24	"	
Domingos Massoni, Carlos	7	M	176.0	75.0	'39 • 1 • 4	"	
Edvar Simoes, Jose	15	M	185.0	80.0	'43 • 4 • 23	"	
Marques, Wlamir	5	M	185.0	79.0	'37 • 7 • 16	"	
Mirshawka, Victor	13	M	189.0	83.0	'41 • 4 • 27	"	
Pasos, Amaury Antonio	4	M	190.0	90.0	'35 • 12 • 11	"	
Pereira Maciel, Ubiratan	6	M	198.0	100.0	'44 • 1 • 18	"	
Salvador Sucar, Antonio	12	M	202.0	98.0	'39 • 6 • 14	"	
Schall, Jatyr Eduardo	10	M	186.0	85.0	'38 • 10 • 18	"	
Wilhem Braun, Friedrich	8	M	193.0	92.0	'41 • 7 • 18	"	
Fabre, Luiz Carlos	25	M	.	.	'48 • 2 • 24	Boxing Boxe	L. Middle
Henrique Da Silva, Joao	24	M	.	.	'46 • 1 • 1	"	L. Welter
Leonidas Cezar, Luiz	26	M	.	.	'38 • 7 • 11	"	Middle
Alves Pereira, Rivadavio	13	M	.	.	'44 • 5 • 4	Football	
Caravetti, Ademar F.	11	M	.	.	'45 • 2 • 4	"	
Dias Oliveira, Helio	12	M	.	.	'43 • 12 • 19	"	
Dos Santos Pereira, Nelio	21	M	.	.	'43 • 12 • 8	"	
Filgueiras Filho, Dimas	14	M	.	.	'44 • 5 • 13	"	
Lopes Miranda, Roberto	7	M	.	.	'43 • 7 • 21	"	
Marques, Jose Roberto	8	M	.	.	'45 • 5 • 31	"	
Mattar Netto Antonio	17	M	.	.	'44 • 11 • 24	"	
Pereira Barros, Mauricio	2	M	.	.	'44 • 2 • 4	"	
Pereira De Souza, Iris	6	M	.	.	'45 • 2 • 12	"	
Pereira, Jose Luiz	3	M	.	.	'43 • 7 • 5	"	
Pinto Junior, Florisvaldo	1	M	.	.	'43 • 5 • 9	"	
Quirino Lemos, Valdez	4	M	.	.	'43 • 2 • 10	"	
Redes Filho, Humberto A.	16	M	.	.	'45 • 6 • 20	"	
Ribeiro Soares, Ivo	10	M	.	.	'38 • 12 • 16	"	
Rosa, Nilton	18	M	.	.	'43 • 3 • 15	"	
Teixeira, Geraldo	9	M	.	.	'37 • 5 • 15	"	
Valentim Filho, Othon	20	M	.	.	'43 • 12 • 18	"	
Vinagre De Godoy, E.A.	19	M	.	.	'45 • 10 • 17	"	
Virgilio Neto, Adevaldo	5	M	.	.	'43 • 8 • 16	"	
Shiozawa, Lhofei		M	165.0	70.0	'41 • 6 • 1	Judo	Middle Weight
De Avila Pires, Alvaro R.		M	.	.	'41 • 8 • 13	Swimming and Diving Natation et Plongeoins	100m Free, 4X100m Medley
De Oliveira Junior, A.P.		M	.	.	'43 • 1 • 3	"	100m Free, 4X100m Medley
Fernandes Fonseca, Mauri		M	.	.	'41 • 9 • 12	"	100m Free, 4X100m Medley
Zablith Filho, Farid		M	.	.	'42 • 8 • 5	"	200m Breast, 4X100m Medley
Pereira, Jose Wilson	12	M	.	.	'35 • 1 • 9	Modern Pentathlon Pentathlon Moderne	
Pessoa Filho, Nelson		M	.	.	'35 • 12 • 16	Equestrian sports Sport Equestre	Jumping Grand Prix
Albano Feitosa, Carlos E.	5	M	180.0	73.0	'41 • 6 • 8	Volley-Ball	
Barcellos Borges, V.M.	10	M	176.0	74.0	'42 • 6 • 26	"	
De Oliveira Ramalho, J.	8	M	182.0	70.0	'37 • 8 • 29	"	
De Victor, Newdon Emanue	4	M	192.0	82.0	'37 • 12 • 25	"	
Franca, Joao Claudio	1	M	185.0	76.0	'43 • 1 • 1	"	
Leao De Oliveira, H.	3	M	175.0	72.0	'34 • 5 • 30	"	
Nuzman, Carlos Arthur	7	M	185.0	78.0	'42 • 3 • 17	"	
Schwartz Da Costa, Josef M.	2	M	185.0	76.0	'41 • 1 • 10	"	
Viotti De Azevedo, Decio	9	M	184.0	73.0	'39 • 10 • 12	"	
Volpi, Marco Antonio	6	M	187.0	84.0	'43 • 7 • 1	"	
Borges Nogueira, Ney		M	.	.	'36 • 7 • 21	Water Polo	
Cochrane Filho, Oswaldo		M	.	.	'33 • 7 • 29	"	
Daniel, Luiz		M	.	.	'36 • 9 • 29	"	
Goncalves Filho, Joao		M	.	.	'34 • 12 • 7	"	

NAME NOM	NO. NO.	SEX SEXE	HEIGHT HAUTEUR	WEIGHT POIDS	DATE OF BIRTH DATE DE NAISSANCE	EVENT EPREUVE
Grijo Filho, Adhemar		M	.	.	'31 • 10 • 18	Water Polo
Kelly Dos Santos, Marvio		M	.	.	'34 • 3 • 17	"
Kesselring Carotini, Ivo		M	.	.	'42 • 2 • 16	"
Kesselring Carotini, P.		M	.	.	'45 • 9 • 10	"
Pincirolí Junior, Pedro		M	.	.	'43 • 12 • 16	"
Stuart Bell, Rodney		M	.	.	'36 • 11 • 6	"
Szabo, Aladar		M	.	.	'33 • 3 • 15	"
Bruder, Joerg		M	.	.	'37 • 11 • 16	Yachting
Hendriksen, Klauss		M	.	.	'34 • 7 • 1	Finn
Herchel Adler, Harry		M	.	.	'28 • 9 • 21	F.Dutchman
Peixoto Lima Ramos, L.C.		M	.	.	'29 • 12 • 24	Star
Roderbourg, Joaquim		M	.	.	'18 • 4 • 8	Star
						F. Dutchman
GREAT BRITAIN GRANDE-BRETAGNE						
Alsop, Frederick John	180	M	185.0	77.5	'38 • 10 • 20	Athletics Athlétisme
Arden, Daphne	49	F	167.0	52.6	'41 • 12 • 29	Long Jump, Triple Jump 100m, 200m, 4X100m
Boulter, John Peter	158	M	185.0	68.0	'40 • 11 • 18	" 800m
Brightwell, Robbie Ian	153	M	188.0	76.0	'39 • 10 • 27	" 400m, 4X400m
Bullivant, Michael John	165	M	183.0	67.5	'34 • 3 • 1	" 10000m
Campbell, Walter Menzies	152	M	188.0	79.5	'41 • 5 • 22	" 200m, 4X100m
Carter, Christopher S.	156	M	184.0	81.0	'42 • 12 • 25	" 800m
Cobb, Violet Madeline	50	F	157.0	50.0	'40 • 7 • 3	" 100m, 4X100m
Cooper, John Hugh	170	M	185.0	82.5	'40 • 12 • 18	" 400m Hurdles, 4X400
Davies, Lynn	149	M	189.0	82.5	'42 • 5 • 20	" 100m, 4X100m, Long Jump
Dean, Graham Alan	157	M	177.0	63.5	'42 • 1 • 26	" 800m
Edgington, John William	188	M	183.0	71.8	'36 • 4 • 5	" 20km Road Walk
Graham, Derek Austin	162	M	188.0	68.0	'41 • 9 • 3	" 5000m
Graham, Timothy J.M.	154	M	178.0	65.0	'39 • 5 • 31	" 400m, 4X400m
Grieveson, Elizabeth Joy	53	F	167.0	58.0	'41 • 10 • 31	" 4000m
Heatley, Benjamin Basil	186	M	172.0	63.0	'33 • 12 • 25	" Marathon
Herring, John Bryan	163	M	180.0	63.0	'35 • 4 • 10	" 5000m
Herriott, Maurice	173	M	178.0	64.0	'39 • 10 • 8	" 3000m S. C.
Hill, Ronald	166	M	168.0	56.0	'38 • 9 • 25	" 10000m, Marathon
Hodson, Mary	57	F	172.0	59.5	'46 • 10 • 28	" 800m
Hogan, John M.W.	171	M	185.0	74.0	'43 • 5 • 9	" 400m Hurdles
Hollingsworth, Roy Anselm	184	M	191.0	97.5	'33 • 12 • 28	" Discus Throw
Hyman, Dorothy	51	F	169.0	57.2	'41 • 5 • 9	" 100m, 200m, 4X100m
Jamieson Louie Alexander	65	F	161.0	58.0	'42 • 4 • 31	" Long Jump
Jones, Ronald	176	M	181.0	78.0	'34 • 8 • 19	" 4X100m
Kilby, Brian Leonard	187	M	170.0	57.0	'38 • 7 • 26	" Marathon
Kippax, Patricia Ann	54	F	170.0	59.0	'41 • 9 • 23	" 400m
Knowles, Linda Yvonne	61	F	177.0	62.5	'46 • 4 • 28	" High Jump
Lindsay, Michael Robert	182	M	185.0	113.0	'38 • 11 • 2	" Shot Put
Lucking, Martyn Taylor	183	M	191.0	102.0	'38 • 3 • 24	" Shot Put
Mathews, Gwenda Mary	62	F	177.0	63.0	'44 • 6 • 6	" High Jump
Mathews, Kenneth Joseph	189	M	185.0	73.5	'34 • 6 • 21	" 20km Road Walk
McKim, William	161	M	183.0	66.5	'41 • 10 • 1	" 1500m
Meakin, Alfred	151	M	176.0	77.0	'38 • 8 • 30	" 100m, 4X100m
Metcalfe, Adrian Peter	155	M	189.0	78.4	'42 • 3 • 2	" 400m, 4X400m
Middleton, Raymond C.	191	M	183.0	74.5	'36 • 8 • 9	" 50km Road Walk
Miller, Gordon Albert	178	M	191.0	85.0	'39 • 12 • 16	" High Jump
Morbey, John Michael	175	M	184.0	77.1	'39 • 8 • 9	" 4X100m, Long Jump
Murray, Alistair Fergus	167	M	179.0	65.7	'42 • 9 • 11	" 10000m
Nihill, Vincent Paul	192	M	176.0	64.0	'39 • 9 • 5	" 50km Road Walk
Packer, Ann Elizabeth	55	F	169.0	56.5	'42 • 3 • 8	" 400m, 800m
Paddick, John Chester	190	M	179.0	65.0	'43 • 8 • 31	" 20km Road Walk
Parker, John Michael	168	M	187.0	80.0	'38 • 5 • 2	" 110m Hurdles
Parkin, Sheila	64	F	168.0	58.5	'45 • 10 • 22	" Long Jump
Payne, Andrew Howard	185	M	184.0	102.0	'31 • 4 • 17	" Hammer Throw
Peters, Mary Elizabeth	66	F	172.0	70.0	'39 • 7 • 6	" Shot put, Pentathlon

NAME NOM	NO. NO.	SEX SEXE	HEIGHT HAUTEUR	WEIGHT POIDS	DATE OF BIRTH DATE DE NAISSANCE	EVENT EPREUVE	
Platt, Susan Mary	67	F	175.0	60.4	'40 • 10 • 4	Athletics Athlétisme	Javelin Throw
Pomfret, Ernest	174	M	174.0	64.0	'41 • 4 • 18	"	3000m S. C.
Pryce, Patricia Anne	58	F	173.0	63.0	'42 • 1 • 4	"	80m Hurdles
Radford, Peter Frank	150	M	187.0	76.0	'39 • 9 • 20	"	100m, 200m, 4X100m
Ralph Michael	181	M	173.0	63.0	'38 • 7 • 4	"	Triple Jump
Rand, Mary Denise	59	F	172.0	59.5	'40 • 2 • 10	"	80m Hurdles, 4X100m, Long Jump, Pentathlon
Sherwood, John	177	M	186.0	79.8	'45 • 6 • 4	"	4X400m
Simpson, Alan	159	M	178.0	67.0	'40 • 5 • 22	"	1500m
Simpson, Janet Mary	52	F	168.0	53.7	'44 • 9 • 2	"	200m, 4X100m
Slaap, Frances Mary	63	F	175.0	61.0	'41 • 6 • 25	"	High Jump
Smith, Anne Rosemary	56	F	169.0	56.5	'41 • 8 • 31	"	800m
Stevenson, David Deas	179	M	178.0	75.0	'41 • 11 • 28	"	Pole Vault
Taitt, Lawrence	169	M	180.0	74.0	'34 • 3 • 28	"	110m Hurdles
Thompson, Donald James	193	M	168.0	55.0	'33 • 1 • 20	"	50km Road Walk
Tranter, Maureen Dorothy	60	F	171.0	63.0	'47 • 5 • 2	"	4X100m
Warden, Peter	172	M	170.0	58.5	'41 • 7 • 7	"	400m Hurdles, 4X400m
Whetton, John	160	M	178.0	68.0	'41 • 9 • 6	"	1500m
Wiggs, Michael Edwin	164	M	185.0	68.0	'38 • 4 • 25	"	5000m
Barry, William Louis		M	188.0	84.8	'40 • 10 • 16	Rowing Aviron	Four, Without Cox
Clay, Michael Charles		M	183.0	75.2	'33 • 8 • 10	"	Reserve, Oarsmen
Cooke, Arnold Vivian		M	184.0	78.5	'41 • 4 • 13	"	Double Sculls
Farquharson, Stewart		M	195.0	87.5	'40 • 4 • 27	"	Pair, Without Cox
James, John Jesse		M	183.0	75.2	'37 • 9 • 21	"	Four, Without Cox
Lee Nicholson, James D.		M	190.0	82.5	'38 • 1 • 31	"	Pair, Without Cox
Russell, John Michael		M	185.0	80.5	'35 • 8 • 3	"	Four, Without Cox
Wardell-Yerburgh, H.A.		M	189.0	83.2	'38 • 1 • 11	"	Four, Without Cox
Webb, Peter James		M	179.0	70.0	'40 • 10 • 2	"	Double Sculls
Dunne, James	30	M	165.0	57.0	'41 • 5 • 14	Boxing Boxe	Light
McCluskey, John	27	M	166.0	51.0	'44 • 1 • 23	"	Fly
McTaggart, Richard	31	M	181.0	63.5	'35 • 10 • 15	"	L. Welter
Packer, Brian	28	M	153.5	54.0	'44 • 3 • 2	"	Bantam
Robinson, William	33	M	186.0	71.0	'36 • 2 • 20	"	L. Middle
Smith, Ronald Anthony	29	M	174.0	.	'44 • 10 • 15	"	Feather
Stack, William Joseph	34	M	177.7	74.8	'36 • 9 • 30	"	Middle
Varley, Michael Andrew	32	M	174.0	67.0	'39 • 11 • 30	"	Welter
Edwards, Alan	20	M	195.0	86.0	'43 • 10 • 21	Canoeing Canotage	Reserve
Lawler, Peter Sidney	21	M	165.0	64.0	'41 • 4 • 25	"	Kayak 4
Lowery, Robert Johnson	22	M	175.0	80.0	'37 • 5 • 22	"	Kayak 4
Palmer, Glenn Ivor	23	M	180.0	72.0	'45 • 3 • 17	"	Kayak 4
Tucker, Marianne	24	F	157.0	54.0	'37 • 10 • 23	"	Kayak 1
Wilson, Alistair C.	25	M	175.0	73.0	'39 • 8 • 20	"	Kayak 1, 4
Addy, Robert Charles	38	M	190.5	76.2	'41 • 1 • 24	Cycling Cyclisme	Road team T. T.
Barton, Karl Edward James	71	M	170.2	68.0	'37 • 7 • 17	"	Scratch, Tandem Sprint
Bull, Trevor Geoffrey	67	M	188.0	79.4	'44 • 12 • 28	"	Team Pursuit
Church, Christopher C.	72	M	170.2	73.2	'40 • 10 • 4	"	Scratch, Tandem Sprint
Cowley, Michael Joseph	45	M	179.1	66.0	'41 • 11 • 8	"	Road Ind., Team T. T.
Harrison, Derek John	46	M	172.7	72.6	'44 • 3 • 5	"	Road Ind., Team T. T.
Jackson, Harry Kenneth	68	M	179.1	74.5	'41 • 5 • 26	"	Team Pursuit
Lewis, Colin	47	M	180.3	69.9	'41 • 7 • 27	"	Ind. Road
McKeown, Brendan Patrick	74	M	161.2	86.2	'44 • 3 • 18	"	Reserve
Porter, Hugh William	69	M	185.4	70.8	'40 • 1 • 27	"	Ind. Team Pursuit
Sandy, Brian	70	M	172.7	66.7	'32 • 11 • 24	"	Team Pursuit
West, Terence Henry	48	M	182.0	69.0	'39 • 9 • 19	"	Road Ind., Team T. T.
Whitfield, Roger Cyril	73	M	172.7	73.0	'43 • 12 • 29	"	1000m Time Trial
Bewley Cathie, Janet C.	38	F	161.0	60.0	'40 • 2 • 15	Fencing Escrime	Foil Ind.
Cawthorne, Derrick	43	M	182.0	72.0	'31 • 4 • 24	"	Foil Team
Cooperman, Arnold Ralph	44	M	174.0	71.0	'27 • 11 • 16	"	Foil, Sabre Team
Durne, Mildred Dorothy	39	F	167.6	62.6	'32 • 2 • 15	"	Foil Team
Hoskyns, Henry William F.	45	M	182.0	71.2	'31 • 3 • 19	"	Foil, Epee Ind., Team, Sabre Team

NAME NOM	NO. NO.	SEX SEXE	HEIGHT HAUTEUR	WEIGHT POIDS	DATE OF BIRTH DATE DE NAISSANCE	EVENT EPREUVE	
Howard, Michael John P.	48	M	170.5	70.0	'28 • 12 • 24	Fencing Escrime	Epee, Sabre Team
Jacobs, Peter	49	M	175.0	65.5	'38 • 9 • 26	"	Epee Ind., Team
Jay, Allan Lomis Neville	46	M	175.0	79.0	'31 • 6 • 30	"	Epee, Foil Ind., Team
Leckie, Alexander Mallace	47	M	180.0	80.0	'38 • 3 • 25	"	Foil, Sabre Ind., Team
Netherway, Shirley	40	F	170.3	63.5	'37 • 5 • 19	"	Foil Team
Offredy, Thoresa Mary	41	F	165.0	60.0	'30 • 5 • 4	"	Foil Team
Oldcorn, Richard	51	M	195.6	89.0	'38 • 2 • 21	"	Sabre Ind., Team
Pelling, John Albert	50	M	179.0	67.0	'36 • 5 • 27	"	Epee team
Watts-Tobin, Mary E.A.B.	42	F	174.0	69.0	'36 • 12 • 21	"	Foil Ind., Team
Goddard, Denise Elizabeth	142	F	160.0	59.4	'45 • 4 • 20	Gymnastics Gymnastique	
Mulhall, John William	93	M	167.6	61.9	'38 • 8 • 18	"	
Pancott, John Edward	92	M	168.0	64.0	'33 • 4 • 1	"	
Rutherford, Monica K.	143	F	160.3	61.2	'44 • 3 • 29	"	
Blackman, Sylvanus T.	102	M	172.3	82.5	'33 • 7 • 1	Weight-Lifting Haltérophilie	L. Heavy
Manners, George Russell	117	M	171.3	83.5	'38 • 1 • 25	"	L. Heavy
Martin, Louis George	137	M	171.3	89.0	'36 • 11 • 11	"	M. Heavy
Newton, George	34	M	162.0	59.3	'36 • 8 • 13	"	Feather
Pearman, Michael Mick	82	M	170.0	75.0	'41 • 5 • 22	"	Middle
Cadman, John Frank	10	M	180.0	75.0	'34 • 3 • 27	Hockey	
Cahill, Harold Alexander	19	M	183.0	77.0	'30 • 6 • 9	"	
Corby, Michael Wells	16	M	182.0	73.0	'40 • 2 • 18	"	
Cutter, Geoffrey Michael	15	M	173.0	64.0	'34 • 10 • 1	"	
Davis, Francis H.V.	7	M	178.0	67.0	'32 • 9 • 24	"	
Deegan, James F.A.	9	M	179.0	71.0	'33 • 11 • 6	"	
Fishwick, Paul Darrell	1	M	174.0	67.0	'36 • 8 • 21	"	
Hindle, John	11	M	165.0	70.0	'46 • 11 • 20	"	
Jones, Charles I.M.	5	M	178.0	72.0	'34 • 10 • 11	"	
Judge, Harold David	3	M	180.0	70.0	'36 • 1 • 19	"	
Land, John James	18	M	170.0	59.0	'38 • 7 • 17	"	
Langhorne, Chris. John	12	M	173.0	66.0	'40 • 9 • 18	"	
Miller, Derek Robert	17	M	177.0	71.0	'36 • 2 • 14	"	
Neill, John Whitley	2	M	188.0	80.0	'34 • 5 • 15	"	
Page, Alan Graham	8	M	172.0	67.0	'37 • 5 • 28	"	
Sutton, Roger Macklin	6	M	178.0	72.0	'36 • 12 • 20	"	
Veit, David Michael	14	M	166.0	66.0	'38 • 10 • 21	"	
Wilman, David	4	M	166.0	68.0	'34 • 12 • 19	"	
Hoare, Sydney Reginald		M	180.0	79.8	'39 • 7 • 18	Judo	Middle Weight
Jacks, Brian Albert T.		M	176.0	67.0	'46 • 10 • 5	"	Light Weight
Petherbridge, David Alan		M	180.0	110.0	'27 • 10 • 9	"	All Weights
Sweeney, Anthony John		M	185.5	86.0	'38 • 5 • 20	"	Heavy Weight
Allen, Leonard John		M	175.0	78.0	'32 • 5 • 22	Wrestling Lutte	Free S.-Welter
Aspen, Albert		M	167.5	63.0	'34 • 3 • 1	"	Free S.-Feather
Buck, Anthony Jude Joseph		M	180.0	97.0	'33 • 12 • 29	"	Free S.-L. Heavy
McNamara, Denis		M	185.0	103.0	'30 • 8 • 27	"	Free S.-Heavy
Pilling, Walter		M	165.0	57.0	'35 • 4 • 18	"	Free S.-Bantam
Stephenson, Kenneth		M	168.0	70.0	'38 • 6 • 12	"	Free S.-Light
Amos, Linda		F	172.5	73.0	'46 • 6 • 22	Swimming and Diving Natation et Plongeoins	100m, 4X100m Free
Candler, John		M	162.5	62.0	'39 • 12 • 13	"	Springboard Diving
Cotterill, Mary Anne		F	167.5	63.0	'45 • 10 • 16	"	100m Butterfly, 4X100m Medley
Cramp, Frances Caroline		F	165.0	59.0	'47 • 6 • 27	"	High Diving
Enfield, Jacqueline Ida		F	162.0	55.0	'47 • 9 • 19	"	200m Breast
Gegan, Judith Ann		F	160.0	62.0	'44 • 11 • 10	"	100m Butterfly
Haller, David Joseph G.		M	184.0	79.0	'45 • 1 • 27	"	100m 4X100m Free
Jenkins, Brian		M	172.5	78.5	'43 • 6 • 20	"	200m Butterfly, 4X100m Medley
Johnson, Pamela		F	161.5	60.5	'48 • 9 • 25	"	400m Ind. Medley
Keen, Sandra		F	170.0	70.0	'47 • 8 • 13	"	100m, 4X100m Free, 4X100m Medley
Kendrew, Peter		M		69.9	'40 • 4 • 25	"	4X100m 4X200m Free
Kitcher, Anthony William		M	175.0	74.0	'41 • 3 • 18	"	High Diving
Lewis, Sylvia Anne		F	173.0	63.0	'41 • 12 • 23	"	100m Back

NAME NOM	NO. NO.	SEX SEXE	HEIGHT HAUTEUR	WEIGHT POIDS	DATE OF BIRTH DATE DE NAISSANCE	EVENT EPREUVE	
Long, Elizabeth Carole		F	162.5	60.0	'46 • 7 • 30	Swimming and Diving	400m, 4X100m Free
Lonsbrough, Anita		F	175.0	68.0	'41 • 8 • 10	Natation et Plongeon	400m Free, 400m Ind. Medley
Lord, Robert Thomas		M	175.0	65.0	'45 • 5 • 6	"	100m, 400m, 4X100m, 4X200m, 4X100m Medley
Ludgrove, Linda Kay		F	155.0	61.0	'47 • 9 • 3	"	100m Back, 4X100m Medley
Martin-Dye, John		M	174.0	83.0	'40 • 5 • 21	"	400m, 4X100m, 4X200m Free
McGregor, Robert Bilslan		M	184.0	79.5	'44 • 4 • 3	"	4X100m, 100m, 4X200m Free, 4X100 Medley
Mitchell, Stella M. M.		F	165.0	58.5	'47 • 7 • 21	"	200m Breast, 4X100m Medley
Newman, Joy		F	161.5	52.0	'45 • 11 • 17	"	High Diving
Nicholson, Neil		M	175.0	75.0	'45 • 1 • 19	"	200m Breast, 4X100m Medley
Norfolk, Jill Rosemary		F	165.0	60.5	'47 • 2 • 15	"	100m Back
Phelps, Brian Eric		M	170.0	72.0	'44 • 4 • 21	"	High Diving
Phillips, Glenda May		F	169.0	70.0	'45 • 5 • 12	"	100m Butterfly
Sillett, Pauline		F	160.0	56.0	'49 • 4 • 22	"	400m, 4X100m Free
Slattery, Jill		F	175.0	68.0	'45 • 5 • 25	"	200m Breast, 4X100m Medley
Thurley, John Philip		M	170.0	66.0	'47 • 12 • 12	"	400m, 1500m Free, 200m Butterfly, 4X100, 4X200m Free, 200m Back, 4X100m Medley
Thwaites, Geoffrey R.		M	167.5	61.0	'47 • 4 • 25	"	100m, 4X100m Free, 4X100m Medley
Wilkinson, Diana E.		F	161.0	64.0	'44 • 3 • 17	"	Medley
Wood, William Ralph		M	160.0	58.0	'46 • 6 • 9	"	High Diving
Finnis, Benjamin F.	18	M	171.0	73.0	'37 • 7 • 8	Modern Pentathlon	
Fox, Jeremy Robert	19	M	188.0	79.0	'41 • 9 • 19	Pentathlon Moderne	
Phelps, Robert Lawson	20	M	171.0	75.0	'39 • 7 • 22	"	
Tuck, Roderick Farndon	21	M	190.0	80.0	'34 • 5 • 28	"	
Barker, David Boston		M	175.0	69.9	'43 • 4 • 12	Equestrian Sports	Jumping Grand Prix
Barker, William John L.		M	177.5	66.7	'46 • 2 • 15	Sport Equestre	Jumping Grand Prix
Broome, David		M	177.5	72.1	'40 • 3 • 1	"	Jumping Grand Prix
Bullen, Michael F.S.		M	189.3	76.2	'37 • 5 • 20	"	Three-Day Event
Hall, Johanna Sybille		F	172.5	57.2	'34 • 5 • 24	"	Dressage Grand Prix
Jones, Reuben Samuel		M	176.8	63.5	'32 • 10 • 19	"	Three-Day Event
Meade, Richard John H.		M	183.0	69.9	'38 • 12 • 4	"	Three-Day Event
Robeson, Peter David		M	178.8	69.9	'29 • 10 • 21	"	Jumping Grand Prix
Templer, James Robert		M	177.5	66.7	'36 • 1 • 8	"	Three-Day Event
Braithwaite, John Robert	13	M	180.3	83.0	'25 • 9 • 28	Shooting	Clay Pigeon
Bray, Alan Herbert	160	M	177.8	65.4	'29 • 6 • 19	Tir	Rapid Fire Pistol
Chivers, Anthony James	157	M	172.7	70.8	'36 • 11 • 30	"	Free Pistol
Clark, Anthony John	159	M	182.9	78.5	'24 • 6 • 17	"	Rapid Fire Pistol
Cullum, Harold	158	M	172.7	78.9	'29 • 8 • 29	"	Free Pistol
Hall, John	156	M	174.0	72.6	'06 • 11 • 12	"	Small Bore-Prone
Morgan, Thomas Peter	155	M	172.7	67.1	'27 • 9 • 21	"	Small Bore-Prone
Wheater, Joseph	12	M	172.7	85.7	'18 • 10 • 6	"	Clay Pigeon
Aisher, Robin Allingham		M	188.0	84.0	'34 • 1 • 24	Yachting	5.5m
Creagh-Osborne, R.P.		M	181.0	76.0	'28 • 4 • 5	"	Reserve
Denham, Eric		M	168.0	83.0	'29 • 9 • 20	"	5.5m
Harris, Jeremy David		M	182.0	70.0	'42 • 12 • 17	"	Dragon
Jardine, Adrian		M	174.0	60.0	'33 • 8 • 23	"	5.5m
Jardine, Stuart		M	174.0	60.0	'33 • 8 • 23	"	Reserve
Mann, Graham Hargrave		M	184.0	92.0	'24 • 6 • 26	"	Reserve
Morgan Arthur William C.		M	176.0	73.0	'31 • 8 • 24	"	F. Dutchman
Musto, Franklyn Keith		M	174.0	72.0	'36 • 1 • 12	"	F. Dutchman
Parry, Edwan Martin		M	170.0	66.0	'35 • 3 • 14	"	Dragon
Reade, Peter John Chorley		M	185.0	70.0	'39 • 1 • 14	"	Dragon
Saffery-Cooper, Brian L.		M	183.0	83.0	'34 • 7 • 9	"	Finn
BULGARIA BULGARIE							
Angelova, Virginia M.	26	F	167.0	78.0	'32 • 1 • 1	Athletics	Discus Throw
Christova, Ivanka M.	25	F	172.0	78.0	'41 • 9 • 19	Athlétisme	Shot Put
Dagorov, Nicola Dimitrov	47	M	183.0	78.0	'35 • 6 • 3	"	400m Hurdles
Gurgushinov, Liuben N.	52	M	172.0	68.0	'31 • 11 • 2	"	Triple Jump
Hlebarov, Dimitre P.	49	M	175.0	66.0	'34 • 9 • 3	"	Pole Vault
Jordanov, Evgeni Yotov	48	M	191.0	83.0	'40 • 5 • 5	"	High Jump
Jorgova, Diana Hristova	24	F	163.0	57.0	'42 • 7 • 9	"	Long Jump

NAME NOM	NO. NO.	SEX SEXE	HEIGHT HAUTEUR	WEIGHT POIDS	DATE OF BIRTH DATE DE NAISSANCE	EVENT EPREUVE	
Kerkova, Snejana Angelova	23	F	168.0	61.0	'38 • 1 • 30	Athletics Athlétisme	100m, 200m, 80m Hurdles
Kostov, Valko Kostov	53	M	176.0	95.0	'36 • 2 • 14	"	Discus Throw
Stoykovski, Georgi Ivanov	51	M	172.0	72.0	'41 • 5 • 10	"	Triple Jump
Stoytchev, Raitcho Zonev	50	M	178.0	71.0	'36 • 2 • 24	"	Long Jump
Mandadjiev, Atanass P.		M	184.0	78.0	'36 • 7 • 19	Rowing Aviron	Pair, Without Cox
Nicolov, Georgi Nicolov		M	191.0	89.0	'38 • 2 • 12	"	Pair, Without Cox
Daraktchiev, Petar Ivanov	38	M	175.0	.	'43 • 3 • 11	Boxing Boxe	L. Welter
Giurov, Giuro Dimitrov	40	M	166.0	.	'42 • 12 • 8	"	Middle
Mitzev, Michail Dimitrov	36	M	160.0	.	'40 • 12 • 6	"	Bantam
Nicolov, Alexander D.	41	M	182.0	.	'40 • 3 • 4	"	L. Heavy
Panayotov, Stefan A.	35	M	158.0	.	'41 • 7 • 26	"	Fly
Pandov, Kiril Borissov	42	M	196.0	.	'43 • 5 • 3	"	Heavy
Petrov, Petar Krumov	39	M	176.0	.	'41 • 9 • 18	"	L. Middle
Pilitchev, Stoyan Angelov	37	M	177.0	.	'38 • 11 • 20	"	Light
Mushev, Bogdan Antonov	26	M	182.0	84.0	'37 • 7 • 22	Canoeing Canotage	Canadian 1
Russeva, Nicolina G.	27	F	160.0	64.0	'43 • 5 • 12	"	Kayak 1
Todorov, Georgi Dimitrov	28	M	173.0	72.0	'27 • 12 • 6	"	Kayak 1
Stefanov, Stefan Kirev	19	M	178.0	75.0	'42 • 10 • 14	Cycling Cyclisme	1000m Time Trial
Alexandrova, Liliana L.	132	F	167.0	67.0	'43 • 2 • 26	Gymnastics Gymnastique	
Batchvarov, Todor G.	236	M	166.0	61.0	'36 • 1 • 8	"	
Christov, Liuben M.	233	M	172.0	66.0	'35 • 7 • 15	"	
Grigorova, Raina Ivanova	131	F	163.0	56.0	'31 • 7 • 25	"	
Kantchev, Marine Nicolov	237	M	163.0	65.0	'37 • 10 • 30	"	
Kapsazov, Velik Nikolov	231	M	166.0	68.0	'35 • 4 • 15	"	
Kondev, Todor Nicolov	235	M	169.0	66.0	'38 • 11 • 16	"	
Mirtchev, Georgi Adamov	234	M	172.0	65.0	'39 • 6 • 3	"	
Prodanov, Nicola Dimitrov	232	M	172.0	68.0	'40 • 5 • 26	"	
Konarov, Veliko K.	90	M	168.0	.	'40 • 1 • 22	Weight-Lifting Haltérophilie	Middle
Penchev, Stantcho Tomov	112	M	173.0	82.0	'40 • 10 • 20	"	L. Heavy
Petrov, Bogomil Tsvetanov	63	M	165.0	.	'40 • 11 • 21	"	Light
Tachev, Petar Vitanov	133	M	172.0	90.0	'38 • 7 • 23	"	M. Heavy
Veselinov, Ivan Todorov	155	M	174.0	.	'20 • 11 • 16	"	Heavy
Alexandrov, Boyan Radev		M	173.0	.	'42 • 2 • 25	Wrestling Lutte	Greco R.-L. Heavy
Bimbalov, Krali Peitchev		M	174.0	.	'34 • 11 • 1	"	Greco R.-Middle
Dermendjiev, Petko A.		M	175.0	.	'36 • 2 • 13	"	Free S.-Welter
Dimov, Enio Valtchev		M	170.0	.	'36 • 1 • 4	"	Free S.-Light
Djiber, Liutvi Ahmedov		M	180.0	.	'30 • 4 • 10	"	Free S.-Heavy
Gardjev, Prodan Stoyanov		M	175.0	.	'36 • 4 • 8	"	Free S.-Middle
Georgiev, Mladen Georgiev		M	160.0	.	'40 • 10 • 16	"	Free S.-Bantam
Georgiev, Stoytcho Malov		M	161.0	.	'43 • 6 • 6	"	Free S.-Fly
Ivanov, Ivan Ivanov		M	166.0	.	'37 • 4 • 24	"	Greco R.-Light
Ivanov, Stantcho Kolev		M	168.0	.	'36 • 4 • 17	"	Free S.-Feather
Kassabov, Radoslav Petrov		M	180.0	.	'38 • 1 • 30	"	Greco R.-Heavy
Kerezov, Angel Stoyanov		M	152.0	.	'39 • 7 • 24	"	Greco R.-Fly
Pashkulev, Zviatko S.		M	162.0	.	'45 • 2 • 4	"	Greco R.-Bantam
Sherifov, Said Mustafafov		M	170.0	.	'33 • 3 • 13	"	Free S.-L. Heavy
Stoykov, Dinko Petrov		M	167.0	.	'35 • 3 • 10	"	Greco R.-Feather
Todorov, Cyril Petkov		M	170.0	.	'33 • 6 • 8	"	Greco R.-Welter
Denev, Dentcho Todorov	118	M	162.0	62.0	'26 • 7 • 22	Shooting Tir	Free, Rapid Fire Pistol
Hristov, Velitchko V.	116	M	173.0	73.0	'34 • 4 • 10	"	Small Bore-3 P., Prone
Koen, Marcel Jussif	117	M	170.0	78.0	'33 • 8 • 3	"	Small Bore-3 P., Prone
Kozlovski, Todor Gavrilov	119	M	174.0	81.0	'33 • 6 • 28	"	Free Pistol
Popov, Stoyan Philipov	120	M	172.0	68.0	'17 • 7 • 25	"	Rapid Fire Pistol
Boyardjiev, Georgi Spassov	11	M	177.0	76.0	'43 • 3 • 18	Volley-Ball	
Christov, Petko Panteleev	4	M	186.0	84.0	'39 • 3 • 6	"	
Giudarov, Boris Vassilev	8	M	189.0	75.0	'27 • 2 • 12	"	
Ivanov, Kiril Metodiev	9	M	190.0	83.0	'43 • 5 • 27	"	
Karov, Dimitre Lukov	1	M	173.0	68.0	'43 • 11 • 27	"	
Konstantinov, Georgi A.	3	M	196.0	99.0	'36 • 10 • 4	"	

NAME NOM	NO. NO.	SEX SEXE	HEIGHT HAUTEUR	WEIGHT POIDS	DATE OF BIRTH DATE DE NAISSANCE	EVENT EPREUVE
Koritarov, Angel B.	12	M	181.0	66.0	'43 • 11 • 27	Volley-Ball
Kotchev, Ivan Petrov	2	M	183.0	78.0	'39 • 7 • 8	"
Kratchmarov, Petar S	5	M	186.0	78.0	'38 • 1 • 31	"
Slavov, Slavtcho Stoyanov	10	M	184.0	78.0	'37 • 2 • 26	"
Srandev, Simeon M.	6	M	194.0	89.0	'39 • 2 • 10	"
Stoyanov, Klatchezar M.	7	M	189.0	84.0	'43 • 1 • 4	"
BURMA BIRMANIE						
Rajan	55	M	172.0	61.0	'35 • 3 • 5	Athletics Athlétisme
Sumbwegam	54	M	167.0	59.0	'30 • 3 • 12	"
Bawa	43	M	167.0	50.5	'44 • 5 • 8	Boxing Boxe
Thein Myint	44	M	165.0	53.5	'37 • 11 • 4	"
Tin Tun	45	M	170.0	56.0	'44 • 11 • 20	"
Chit Mya	16	M	162.0	56.0	'39 • 11 • 17	Weight-Lifting Halterophilie
Mya Thein	64	M	167.0	67.5	'36 • 3 • 10	"
Pe Aye	79	M	166.0	74.0	'36 • 10 • 10	"
Tin Maung Ni		M	172.0	69.0	'38 • 5 • 5	Swimming and Diving Natation et Plongeon
Kyaw Aye	122	M	176.0	67.0	'39 • 2 • 28	Shooting
Kyaw Shein	121	M	165.0	71.0	'38 • 3 • 8	"
CAMBODIA CAMBODGE						
Ek, Sam An	46	M	163.0	54.0	'44 • 1 • 16	Boxing Boxe
Khiru, Soeun	47	M	167.0	57.0	'43 • 9 • 7	"
Touch, Nol	49	M	171.0	63.5	'41 • 1 • 3	"
You, Chin Hong	48	M	168.0	60.0	'41 • 6 • 4	"
Hok Phloy	14	M	170.0	61.0	'37 • 4 • 5	Cycling Cyclisme
Khem Son	22	M	163.0	52.0	'41 •	"
Mak Kham An	13	M	164.0	63.0	'36 • 8 • 1	"
Ret Chhon	12	M	163.0	55.0	'40 •	"
Tan Thol	20	M	161.0	54.0	'41 • 4 • 2	"
Tim Phivana	21	M	165.0	60.0	'40 • 6 • 3	"
Van Hiep	23	M	158.0	48.0	'43 •	"
Van Son	14	M	164.0	48.0	'34 • 4 • 4	"
Yi Yuong	15	M	170.0	62.0	'37 •	"
An, Dandara		M	.	.	'40 • 4 • 8	Yachting
Kim, Nal		M	.	.	'40 • 10 • 21	"
Kim, Tal		M	.	.	'44 • 7 • 13	"
Touch, Kim Sy		M	.	.	'40 • 8 • 13	"
CAMEROONS CAMEROUN						
Njitock, David	75	M	175.0	71.0	'41 • 6 • 17	Athletics Athlétisme
CANADA CANADA						
Bertoia, Donald Richard	58	M	173.0	70.5	'40 • 2 • 16	Athletics Athlétisme
Crothers, William F.	57	M	.	.	'40 • 12 • 24	"
Gairdner, William Douglas	61	M	180.3	81.9	'40 • 10 • 19	"
Gerace, Dianne Roberta	31	F	179.0	68.0	'43 • 10 • 26	"
Hoffman, Abigail	28	F	170.0	59.0	'47 • 2 • 11	"
Jerome, Harry	56	M	180.0	80.0	'40 • 9 • 30	"
Kidd, Bruce	60	M	171.0	65.0	'43 • 7 • 26	"
Leps, Ercas	59	M	182.0	73.0	'39 • 8 • 25	"
McCredie, Nancy Cranwell	32	F	176.5	78.0	'45 • 2 • 5	"
Moro, Guerrino	63	M	163.0	81.8	'43 • 4 • 17	"
Nuttall, Clifford Ross	62	M	184.0	83.0	'40 • 12 • 31	"
Oakley, Alex Harold	64	M	176.5	85.3	'29 • 4 • 26	"
Piotrowski, Irena Maria	27	F	164.0	62.0	'41 • 7 • 9	"
Snider, Amy Marion	29	F	166.0	56.7	'42 • 5 • 26	"
Wingerson, Jennife R. Anne	30	F	177.8	68.0	'43 • 4 • 12	"
Bordewick, Richard Johan		M	195.0	91.0	'39 • 4 • 18	Rowing Aviron
Brookson, Robert Sidney		M	186.0	79.5	'39 • 4 • 15	"
Campbell, Neil William		M	192.0	79.5	'30 • 3 • 9	"
Gotfredsen, Leif		M	186.0	86.0	'34 • 6 • 28	"
Gray, Thomas Lewis		M	183.0	83.5	'36 • 1 • 24	"

NAME NOM	NO. NO.	SEX SEXE	HEIGHT HAUTEUR	WEIGHT POIDS	DATE OF BIRTH DATE DE NAISSANCE	EVENT EPREUVE	
Hungerford, George W.		M	195.0	85.5	'44 • 1 • 2	Rowing Aviron	Pair, Without Cox
Jackson, Roger Charles		M	198.0	84.0	'42 • 1 • 14	"	Pair, Four, Without Cox
Larsen, John Edward		M	192.0	88.0	'43 • 9 • 23	"	Eight, With Cox
Leach, David Christopher		M	195.0	80.5	'42 • 2 • 10	"	Four, Without Cox
Lfimbux, Marc		M	195.0	82.0	'39 • 6 • 22	"	Eight, With Cox
Macdonald, Daryl Raymond		M	183.0	79.5	'34 • 11 • 20	"	Four, Without Cox
Overton, David Roy		M	177.0	53.0	'43 • 8 • 18	"	Eight, With Cox
Pretty, Donald Wayne		M	192.0	86.5	'36 • 6 • 11	"	Eight, With Cox
Sturdy, Daryl Roy		M	201.0	85.0	'40 • 7 • 28	"	Eight, With Cox
Wieczorek, Max		M	192.0	89.0	'39 • 4 • 28	"	Eight, With Cox
Worobieff, Eldon		M	201.0	92.0	'39 • 5 • 17	"	Eight, With Cox
Birtles, Walter Allen	10	M	198.0	90.0	'37 • 4 • 16	Basket-Ball	
Dacyshyn, John	14	M	190.0	90.0	'35 • 3 • 9	"	
Goldring, Rollit James	11	M	198.0	90.0	'37 • 4 • 14	"	
Hartley, Keith Chapman	8	M	200.0	85.0	'40 • 10 • 15	"	
Howson, Barry Franklin	6	M	188.0	76.0	'39 • 6 • 17	"	
Ingaldson, Fred Einer	12	M	190.0	85.0	'32 • 9 • 2	"	
Maguire James W. H.	7	M	195.0	83.0	'39 • 9 • 28	"	
McKibbon, John Hubert	13	M	200.0	97.0	'39 • 9 • 14	"	
Reynolds, Warren Alfred	9	M	193.0	88.0	'36 • 5 • 26	"	
Richman, Reuben	5	M	175.0	72.0	'34 • 9 • 22	"	
Stulac, George William	15	M	183.0	83.0	'33 • 6 • 28	"	
Stulac, Joseph	4	M	175.0	72.0	'35 • 3 • 6	"	
Desrosiers Frederick C.	54	M	175.0	67.0	'40 • 6 • 14	Boxing Boxe	Welter
Henry, John Walter	50	M	167.0	51.0	'37 • 7 • 28	"	Fly
McGrandle, William	51	M	168.0	54.0	'47 • 7 • 4	"	Bantam
Palmer, Campbell R.	52	M	175.0	60.0	'36 • 4 • 29	"	Light
Reti, Harvey	53	M	173.0	63.5	'37 • 9 • 14	"	L. Welter
Brown, Michael	29	M	180.3	73.9	'37 • 8 • 21	Canoeing Canotage	Kayak 2, 4
Elbert, Andor	30	M	182.9	78.9	'34 • 10 • 29	"	Canadian 2
Heese, Fred	31	M	182.9	81.6	'43 • 2 • 21	"	Canadian 2
Joo, Gabor	32	M	176.0	70.0	'37 • 3 • 12	"	Kayak 2, 4
Simonyik, Arpad	33	M	185.4	81.6	'40 • 2 • 23	"	Kayak 1, 4
Stahl, Paul	34	M	182.9	79.4	'40 • 5 • 18	"	Canadian 1, Kayak 4
Andru, John	54	M	155.5	77.5	'32 • 11 • 20	Fencing Escrime	Foil, Epee, Sabre Ind.
Foxcroft, Robert	53	M	180.0	75.0	'34 • 8 • 17	"	Foil, Epee, Sabre Ind.
Weidel, Pacita	52	F	159.0	50.0	'33 • 3 • 31	"	Foil Ind.
Daley, Gail Marion	141	F	156.0	47.0	'46 • 4 • 5	Gymnastics Gymnastique	
Kihn, Richard	121	M	172.0	70.0	'35 • 8 • 15	"	
Larose, Gilbert	122	M	165.0	75.0	'42 • 9 • 13	"	
Weiler, Wilhelm Friedrich	123	M	172.0	74.0	'36 • 3 • 1	"	
Jean, Pierre St.	80	M	178.0	74.0	'43 • 3 • 28	Weight-Lifting Halterophilie	Middle
Lewis, John	134	M	180.0	90.0	'43 • 1 • 19	"	M. Heavy
Salter, Allen	32	M	160.0	60.0	'36 • 10 • 11	"	Feather
Aldridge, Ronald Charles	1	M	180.3	66.8	'33 • 7 • 8	Hockey	
Anderson, Derrick John	11	M	180.3	75.0	'36 • 6 • 20	"	
Boyd, Anthony Donald	4	M	170.0	57.2	'32 • 4 • 2	"	
Buckland, Peter Channing	9	M	181.7	81.7	'41 • 3 • 12	"	
Chopping, Richard James	10	M	181.0	81.2	'31 • 9 • 11	"	
Heidinger, Gerd	7	M	190.5	84.1	'34 • 6 • 19	"	
Johnston, Raymond Ian	6	M	179.3	77.2	'29 • 3 • 3	"	
Preston, Harry Neil	19	M	172.5	84.1	'31 • 7 • 25	"	
Raphael, Alan Mervyn	13	M	170.0	68.2	'31 • 12 • 26	"	
Rouan, Oerara Christopher	15	M	175.2	70.5	'32 • 12 • 10	"	
Ruttle, Reginald P. S.	8	M	179.0	68.2	'31 • 1 • 11	"	
Vander Pyl, Arend Peter	16	M	185.5	84.1	'33 • 11 • 9	"	
Warren, Victor Henry V.	2	M	177.8	77.2	'37 • 8 • 19	"	
Wheaton, Michael John	20	M	177.8	77.2	'28 • 9 • 2	"	
Wright, Lee Madison	3	M	182.8	77.2	'44 • 8 • 28	"	

NAME NOM	NO. NO.	SEX SEXE	HEIGHT HAUTEUR	WEIGHT POIDS	DATE OF BIRTH DATE DE NAISSANCE	EVENT EPREUVE
Yeoman, Andrew Harry	14	M	178.0	72.6	'33 • 12 • 24	Hockey
Young, John Gilbert	5	M	182.8	73.5	'34 • 2 • 22	Judo Heavy Weight
Rogers, Alfred H. D.		M	190.0	115.0	'41 • 1 • 26	Wrestling Lutte Free S.-Light
Doner, Roger		M	172.0	70.0	'38 • 7 • 12	" Free S.-Bantam
Hirabayashi, Koji		M	169.0	57.0	'42 • 1 • 5	" Free S.-Feather
Jutila, Matti		M	168.0	63.0	'32 • 9 • 17	" Greco R.-Feather
Oberlander, Philip		M	173.0	78.0	'39 • 8 • 17	" Free S.-Welter
Dinsley, Thomas Edward		M	166.0	64.0	'41 • 6 • 25	Swimming and Diving Natation et Plongeurs Springboard, High Diving
Gilchrist, John Alexander		M	185.0	80.0	'45 • 11 • 9	" 100m, 400m, 1500m, 4X100m, 4X200m, Free 400m Ind. Medley
Hounsell, Barbara		F	165.0	50.0	'51 • 7 • 6	" 4X100m Medley, 400m, 4X100m, Free, 400m Ind. Medley
Hughes, Jane Marrian		F	163.0	54.5	'48 • 6 • 30	" 4X100m Medley, 400m Free, 4X100m
Humeniuk, Marianne		F	163.0	54.0	'47 • 10 • 14	" 100m Butterfly, 4X100m Free, 4X100m Medley
Hutton, Ralph		M	180.0	75.0	'48 • 3 • 6	" 100m, 400m, 4X100m, 4X200m Free, 200m Back, 200m Butterfly, 400m Ind. 4X100m Medley,
Jacks, Ronald Brian		M	180.0	73.0	'48 • 1 • 23	" 400m, 4X100m, 4X200m Free 200m Back, 4X100m Medley
Kennedy, Helen Louise		F	169.0	61.0	'49 • 8 • 16	" 100m, 4X100 Free, 100m Back, 100m Butterfly, 400m Ind. Medley, 4X100m Medley
Lay, Marion Beverly		F	165.0	55.0	'48 • 11 • 26	" 100m, 4X100m Free, 4X100m Medley
Morrow, Carol Ann		F	163.0	56.0	'46 • 4 • 6	" Springboard, High Diving
Sherry, Daniel John		M	180.0	76.0	'46 • 4 • 2	" 100m, 200m Butterfly, 4X100m Medley, 4X100m, 4X200m Free
Stewart, Judy Leona		F	150.0	45.5	'44 • 8 • 14	" Springboard, High Diving
Stewart, Mary Pauline		F	164.0	56.0	'45 • 12 • 8	" 100m, 4X100m Free, 100m Butterfly, 4X100m Medley
Thompson, Patricia E.		F	156.0	52.0	'45 • 12 • 5	" 400m, Free, 4X100m Medley
Weir, Eilleen		F	146.0	51.0	'46 • 1 • 29	" 100m Back, 4X100m Free, 4x100 Medley
Fischer-Credo, Inez		F	168.0	58.0	'28 • 9 • 10	Equestrian Sports Sport Equestre Dressage Grand Prix
Hanson, Christilot		F	167.0	50.0	'47 • 4 • 2	" Dressage Grand Prix
Boa, Gilmour S.	124	M	178.0	77.0	'24 • 8 • 8	Shooting Tir Small Bore-3 P., Prone
Hare, William E.	125	M	173.0	75.0	'35 • 5 • 14	" Free, Rapid Fire Pistol
Marsh, George S.	123	M	173.0	66.0	'38 • 6 • 9	" Free Rifle, Small Bore-3 P., Prone
McMahon, Garfield W.	126	M	173.0	68.0	'32 • 2 • 25	" Free, Rapid Fire Pistol
Natgrass, Floyd C.	20	M	183.0	95.0	'18 • 1 • 2	" Clay Pigeon
Willsie, Harry A.	19	M	176.5	75.0	'28 • 12 • 20	" Clay Pigeon
Botterell, Edward		M	170.0	63.5	'31 • 1 • 24	Yachting Dragon
Henderson, Paul		M	173.0	77.0	'34 • 11 • 17	" F. Dutchman
Kirby, Bruce		M	188.0	88.5	'29 • 1 • 2	" Finn
Lennox, R. A.		M	173.0	77.0	'38 • 8 • 14	" F. Dutchman
McBrien, J. J.		M	177.0	74.0	'25 • 2 • 20	" Dragon
McDonald, S. A.		M	172.3	71.5	'04 • 9 • 7	" 5.5m
Miller, Dave		M	180.0	68.0	'43 • 9 • 18	" Star
Skinner, G. Bernard		M	182.0	81.5	'30 • 7 • 10	" 5.5m
Thomas William G.		M	174.0	72.5	'25 • 10 • 31	" Reserve
Watters, Lynn A.		M	173.0	70.3	'16 • 11 • 20	" Dragon
West, William		M	188.0	87.5	'31 • 12 • 1	" Star
Woodward, J. D.		M	175.0	84.0	'25 • 3 • 14	" 5.5m
CEYLON CEYLAN						
De Alwis, Adambarage L.	65	M	171.2	67.3	'40 • 3 • 17	Athletics Athlétisme 100m, 200m, 400m
Karunananda, R. J. K.	67	M	167.2	52.5	36 • 5 • 21	" 10000m, 5000m, Marathon
Khan, Ameer S. M.	66	M	165.0	51.5	39 • 8 • 26	" 800m, 1500m
Ratnam, Lorraine E.	33	F	168.0	48.0	39 • 10 • 6	" 100m, 200m, 80m Hurdles
Bulner, Malcolm	56	M	180.0	67.0	44 • 7 • 8	Boxing Boxe Welter
Van Cuylenburg, Winston	55	M	168.0	51.0	43 • 1 • 11	" Fly
Fernando, Ernest P. B.		M	156.0	52.0	38 • 10 • 26	Wrestling Lutte Free S.-Fly
Fernando, Joseph M. A.		M	166.0	57.0	40 • 8 • 25	" Free S.-Bantam
Jayewardene, Ravi Vimal	127	M	180.0	61.6	36 • 4 • 22	Shooting Tir Small Bore-Prone
Perera, Habarakadage R.	128	M	174.0	68.9	'32 • 5 • 14	" Small Bore-Prone
CHAD TCHAD						
Idriss, Mahamat	71	M	183.0	83.0	42 • 7 • 17	Athletics Athlétisme High Jump
Issa, Ahmed	70	M	174.0	59.0	43 • 7 • 17	" 800m, 1500m
CHILE CHILI						
Etcheverry, Patricio	73	M	170.0	70.0	43 • 3 • 6	Athletics Athlétisme Javelin Throw
Moreno, Ivan	72	M	167.0	68.0	42 • 1 • 14	" 100m, 200m

NAME NOM	NO. NO.	SEX SEXE	HEIGHT HAUTEUR	WEIGHT POIDS	DATE OF BIRTH DATE DE NAISSANCE	EVENT EPREUVE	
Vidal, Ricardo	74	M	179.0	66.0	'30 • 9 • 10	Athletics Athlétisme	Marathon
Molina, Mario	57	M	172.0	57.0	'44 • 12 • 16	Boxing Boxe	Feather
Slinas, Guillermo	60	M	178.0	75.0	'38 • 1 • 27	"	Middle
Vilugron, Misael	59	M	174.0	67.0	'38 • 2 • 12	"	Welter
Zuniga, Luis	58	M	167.0	60.0	'39 • 7 • 4	"	Light
Gloffka, Aquiles	56	M	185.0	73.0	'37 • 1 • 3	Fencing Escrime	Epee Ind.
Jimenes, Sergio	57	M	178.0	72.0	'40 • 10 • 19	"	Epee Ind.
Vergara, Sergio	55	M	185.0	81.0	'27 • 11 • 29	"	Epee Ind.
Gloffka, Aquiles	13	M	185.0	73.0	'37 • 1 • 3	Modern Pentathlon Pentathlon Moderne	
Perez, Alejandro		M	162.0	64.0	'26 • 6 • 27	Equestrian Sports Sport Equestre	Jumping Grand Prix
Simonetti, Americo		M	176.0	65.0	'36 • 9 • 16	"	Jumping Grand Prix
Huber, Roberto	129	M	178.0	75.0	'27 • 2 • 2	Shooting Tir	Small Bore-Prone
Lira, Mario Enrique	35	M	182.0	70.0	'27 • 12 • 31	"	Clay Pigeon
Navarro, Gilberto	36	M	178.0	78.0	'29 • 5 • 19	"	Clay Pigeon
COLOMBIA COLOMBIE							
Grajales Escobar, P. A.	77	M	175.0	71.0	'40 • 6 • 14	Athletics Athlétisme	200m, 400m
Gutierrez Hernandez, F. J.	76	M	175.0	70.0	'41 • 12 • 3	"	100m, 200m
Mejia Florez, Alvaro	79	M	177.0	65.0	'40 • 5 • 15	"	5000m, 10000m
Neira Carvajal, J. G.	78	M	178.0	62.0	'39 • 1 • 13	"	800m, 1500m
Bustos Camacho, Eduardo	25	M	180.0	70.0	'37 • 4 • 23	Cycling Cyclisme	1000m T. T., Scratch Sprint, Team Pursuit
Escobar Goetz, Mario	26	M	180.0	68.0	'40 • 2 • 14	"	Team Pursuit
Gomez Bedoya, Ruben Dario	18	M	162.0	58.0	'40 • 3 • 3	"	Road Ind., Team T. T.
Hernandez Lopez, Pablo E.	27	M	175.0	67.0	'40 • 2 • 12	"	Team Pursuit, Road Ind., Team T. T.
Rodriguez Gutierrez, M. E.	30	M	180.0	73.0	'42 • 4 • 13	"	Ind. Pursuit, Road
Sanchez, Pedro J.	21	M	170.0	64.0	'40 • 4 • 8	"	Road Ind., Team T. T.
Suarez, Javier	28	M	166.0	61.0	'43 • 11 • 3	"	Team Pursuit, Road Team T. T.
Vanegas Jimenez, Mario	29	M	170.0	74.0	'39 • 7 • 22	"	Scratch Sprint
Echeverri, Emilio	58	M	175.0	75.0	'29 • 3 • 8	Fencing Escrime	Foil, Epee, Sabre Ind., Team
Posada, Humberto	62	M	166.0	64.0	'22 • 9 • 5	"	Sabre Ind., Foil, Epee, Team
Posada, Ignacio	61	M	172.0	65.0	'35 • 3 • 2	"	Foil, Sabre Ind., Team
Sastre Ernesto	59	M	167.0	66.0	'26 • 12 • 17	"	Epee Ind., Foil, Epee Team
Tamayo, Didier	60	M	170.0	67.0	'38 • 7 • 20	"	Foil, Epee Ind.. Team
Tavera, Hermann	63	M	162.0	54.0	'27 • 5 • 18	"	Sabre Ind., Epee Team
Arango, Julio		M	163.0	57.0	'50 • 6 • 7	Swimming and Diving Natation et Plongeon	400m, 1500m Free
Henao, Diego		M			'47 • 1 • 9	"	High Diving
Clopatofsky, T. A.	130	M	176.0	77.0	'21 • 4 • 20	Shooting Tir	Free, Rapid Fire Pistol
Millon, Juan B.		M	176.0	79.0	'23 • 7 • 25	"	Free Rifle
CONGO CONGO							
Elende, Henri	69	M	177.0	69.0	'41 • 11 • 13	Athletics Athlétisme	High Jump
Yombe, Leon	68	M	176.0	70.0	'44 •	"	100m
COSTA RICA COSTA RICA							
Barquero, Rafael		M			'34 • 6 • 27	Judo	Middle Weight
Madrigal, Orland		M	163.0	78.0	'21 • 3 • 13	"	Middle Weight
CUBA CUBA							
Betancourt, Lazaro	81	M	172.0	70.0	'37 • 7 • 30	Athletics Athlétisme	100m, 110m Hurdles
Cobian, Miguelina	34	F	170.0	59.3	'41 • 12 • 19	"	100m, 200m
Figuerola, Enrique	80	M	167.0	67.0	'38 • 7 • 15	"	100m, 200m
Campbell, Gilberto		M	190.0	85.0	'40 • 4 • 7	Rowing Aviron	Four, Eight With Cox
Diaz, Osvaldo		M	176.0	75.0	'43 • 3 • 28	"	Four, Eight With Cox
Hernandez, Alfredo		M	174.0	78.0	'41 • 12 • 24	"	Four, Eight With Cox
Marrero, Norge		M	182.0	78.0	'43 • 11 • 12	"	Eight With Cox
Milla, Leovigildo		M	176.0	77.0	43 • 8 • 20	"	Four, Eight With Cox
Montenegro, Ezequiel		M	190.0	86.0	'42 • 4 • 10	"	Eight With Cox
Mora, Segundo		M	183.0	78.0	'37 • 5 • 8	"	Eight With Cox
Ojeda, Roberto		M	154.0	47.0	'42 • 3 • 14	"	Four, Eight With Cox
Padron, Manuel		M	185.0	76.0	'20 • 4 • 6	"	Reserve, Cox
Tabio, Mario		M	182.5	78.0	'42 • 2 • 4	"	Eight With Cox
Betancourt, Felix	65	M	172.0	63.0	'45 • 10 • 12	Boxing Boxe	L. Welter
Caminero, Roberto	63	M	170.0	57.0	'45 • 4 • 27	"	Feather

NAME NOM	NO. NO.	SEX SEXE	HEIGHT HAUTEUR	WEIGHT POIDS	DATE OF BIRTH DATE DE NAISSANCE	EVENT EPREUVE	
Carbonell, Rafael	61	M	156.0	49.5	'43 • 11 • 25	Boxing Boxe	Fly
Espinosa, Fermin	62	M	158.0	54.0	'40 • 7 • 7	"	Bantam
Hita, Bienvenido	64	M	169.0	60.0	'44 • 11 • 2	"	Light
Jimenez, Virgilio	66	M	175.0	67.0	'40 • 6 • 2	"	Welter
Penabella, Enrique	65	M	167.0	59.0	'38 • 11 • 24	Fencing Escrime	Foil, Sabre Ind.
Rodriguez, Mireya	64	F	165.0	56.0	'36 • 11 • 26	"	Foil Ind.
Garcia, Carlos	245	M	163.0	62.0	'42 • 9 • 11	Gymnastics Gymnastique	
Gonzalez Andres	243	M	166.0	59.0	'45 • 12 • 4	"	
Hernandez, Pablo, Luis	246	M	173.0	61.0	'44 • 11 • 1	"	
Padron, Felix	244	M	165.0	61.0	'36 • 8 • 1	"	
Ramirez, Hector	242	M	174.0	64.0	'43 • 1 • 31	"	
Suarez, Octavio	241	M	174.0	65.0	'44 • 7 • 26	"	
Varona, Ernesto	148	M	175.0	104.0	'40 • 11 • 7	Weight-Lifting Halterophilie	Heavy
CZECHOSLOVAKIA TCHECOSLOVAQUIE							
Bilek, Alexander	92	M	178.0	67.0	'41 • 1 • 20	Athletics Athletisme	20km, 50km Road Walk
Chudomel, Vaclav	90	M	173.0	67.0	'32 • 9 • 27	"	Marathon
Danek, Ludvik	80	M	193.0	103.0	'37 • 1 • 6	"	Discus Throw
Kantorek, Pavel	91	M	176.0	63.0	'30 • 2 • 8	"	Marathon
Lehocka, Eva	35	F	165.0	54.0	'43 • 7 • 26	"	100m, 200m
Matousek, Josef	89	M	180.0	97.0	'28 • 9 • 7	"	Hammer Throw
Nemcova, Jirina	36	F	175.0	80.0	'37 • 4 • 3	"	Discus Throw
Odlozil, Josef	84	M	175.0	68.0	'38 • 11 • 11	"	1500m
Tomas, Josef	85	M	177.0	67.0	'34 • 3 • 12	"	5000m, 10000m
Tomasek, Rudolf	86	M	178.0	73.0	'37 • 8 • 11	"	Pole Vault
Trousil, Josef	83	M	182.0	70.0	'35 • 2 • 2	"	400m
Zemba, Jiri	87	M	183.0	102.0	'39 • 11 • 17	"	Discus Throw
Andrs, Vladimir		M	176.0	75.0	'37 • 5 • 12	Rowing Aviron	Double Sculls
Cermak, Petr		M	190.0	80.0	'42 • 1 • 24	"	Eight, With Cox
Chalupa, Vaclav		M	190.0	95.0	'34 • 10 • 31	"	Pair, With Cox
Hofman, Pavel		M	182.0	82.0	'38 • 1 • 29	"	Double Sculls
Janousek Bohumil		M	183.0	82.0	'37 • 9 • 7	"	Eight, With Cox
Karafiát, Karel		M	187.0	75.0	'41 • 10 • 21	"	Four, With Cox
Konicek, Miroslav		M	168.0	54.0	'36 • 4 • 18	"	Eight, With Cox
Kozak, Vaclav		M	179.0	75.0	'37 • 4 • 14	"	Single Sculls
Libal, Rene		M	180.0	77.0	'37 • 7 • 15	"	Four, With Cox
Lundak, Jiri		M	187.0	77.0	'39 • 8 • 31	"	Eight, With Cox
Lusk, Stanislav		M	179.0	78.0	'31 • 11 • 12	"	Reserve, Oarsmen
Mejstrik, Zdenek		M	166.0	50.0	'48 • 1 • 1	"	Pair, With Cox
Mrvik, Jan		M	189.0	83.0	'39 • 3 • 29	"	Eight, With Cox
Novy, Richard		M	187.0	84.0	'37 • 4 • 3	"	Eight, With Cox
Palko, Jiri		M	194.0	88.0	'41 • 3 • 17	"	Pair, With Cox
Poisl, Arnost		M	173.0	53.0	'39 • 12 • 2	"	Four, With Cox
Pojezny, Ludek		M	191.0	88.0	'37 • 3 • 7	"	Eight, With Cox
Starosta, Jaroslav		M	190.0	86.0	'37 • 4 • 21	"	Four, With Cox
Stefan, Jan		M	183.0	81.0	'43 • 9 • 2	"	Four, With Cox
Tocek, Julius		M	188.0	86.0	'39 • 9 • 29	"	Eight, With Cox
Ventus, Josef		M	187.0	87.0	'31 • 2 • 12	"	Eight, With Cox
Kucera, Vladimir	68	M	175.0	63.0	'42 • 9 • 29	Boxing Boxe	L. Welter
Nemec, Josef	71	M	187.0	89.0	'33 • 9 • 25	"	Heavy
Nemecek, Bohumil	69	M	185.0	67.0	'38 • 1 • 2	"	Welter
Polacek, Frantisek	70	M	183.0	81.0	'40 • 1 • 20	"	L. Heavy
Slajs, Jaroslav	67	M	164.0	54.0	'42 • 3 • 14	"	Bantam
Houzim, Miloslav	35	M	180.0	78.0	'41 • 6 • 29	Canoeing Canotage	Canadian 2
Hradilova, Zdenka	36	F	165.0	63.0	'38 • 4 • 27	"	Kayak 1
Jiran, Jan	37	M	178.0	78.0	'41 • 6 • 19	"	Canadian 1
Penkava, Rudolf	38	M	182.0	82.0	'45 • 11 • 21	"	Canadian 2
Daller, Jiri	31	M	184.0	82.0	'40 • 3 • 8	Cycling Cyclisme	Ind. Team Pursuit.
Grac, Daniel	23	M	179.0	79.0	'43 • 6 • 13	"	Ind. Road
Kriz, Antonin	32	M	181.0	75.0	'43 • 10 • 29	"	Team Pursuit

NAME NOM	NO. NO.	SEX SEXE	HEIGHT HAUTEUR	WEIGHT POIDS	DATE OF BIRTH DATE DE NAISSANCE	EVENT EPREUVE	
Kucirek, Ivan	37	M	175.0	73.0	'46 • 11 • 25	Cycling Cyclisme	Scratch Sprint
Paar, Karel	35	M	180.0	79.0	'45 • 1 • 3	"	Tandem Sprint
Pecka, Jiri	33	M	179.0	74.0	'40 • 10 • 6	"	1000m T. T., Team Pursuit
Rezac, Frantisek	34	M	180.0	77.0	'43 • 1 • 1	"	Team Pursuit, Ind. Road
Smolik, Jan	25	M	179.0	73.0	'42 • 12 • 24	"	Ind. Road
Stark, Karel	36	M	176.0	73.0	'42 • 2 • 25	"	Tandem Sprint
Brumovsky, Jan	16	M	169.0	60.0	'37 • 6 • 26	Football	
Cvetler, Ludevit	7	M	171.0	69.0	'38 • 9 • 17	"	
Geleta, Jan	6	M	171.0	69.0	'43 • 9 • 13	"	
Knebort, Frantisek	15	M	177.0	76.0	'44 • 1 • 19	"	
Knesl, Karel	12	M	183.0	81.0	'42 • 4 • 8	"	
Lichtnegl, Karel	9	M	177.0	74.0	'36 • 8 • 30	"	
Masny, Vojtech	10	M	166.0	59.0	'38 • 7 • 8	"	
Matlak, Stefan	13	M	176.0	72.0	'34 • 2 • 6	"	
Mraz, Ivan	8	M	182.0	82.0	'41 • 5 • 24	"	
Nepomucky, Karel	14	M	173.0	71.0	'39 • 7 • 20	"	
Picman, Karel Zdenek	4	M	173.0	73.0	'33 • 1 • 23	"	
Schmucker, Frantisek	1	M	185.0	83.0	'40 • 1 • 28	"	
Svajlen, Anton	21	M	184.0	86.0	'37 • 12 • 3	"	
Urban, Anton	2	M	175.0	74.0	'34 • 1 • 16	"	
Valosek, Frantisek	11	M	166.0	65.0	'37 • 7 • 12	"	
Vojta, Josef	5	M	173.0	73.0	'35 • 4 • 19	"	
Weiss, Vladimir	3	M	178.0	80.0	'39 • 9 • 21	"	
Bocko, Frantisek	37	M	164.0	61.0	'41 • 7 • 9	Gymnastics Gymnastique	
Caslavska, Vera	121	F	160.0	55.0	'42 • 5 • 3	"	
Gajdos, Pavel	34	M	170.0	68.0	'36 • 12 • 6	"	
Klecka, Karel	31	M	174.0	73.0	'36 • 7 • 1	"	
Krajcirova, Marie	125	F	156.0	42.0	'48 • 6 • 1	"	
Krbec, Premysl	33	M	167.0	70.0	'40 • 1 • 28	"	
Kubicka, Vaclav	32	M	169.0	66.0	'39 • 9 • 28	"	
Mudrik, Bohumil	36	M	170.0	64.0	'41 • 12 • 3	"	
Pazdera, Ladislav	35	M	171.0	65.0	'36 • 12 • 6	"	
Posnerova, Jana	126	F	159.0	55.0	'45 • 1 • 9	"	
Rimnacova, Bohumila	127	F	163.0	55.0	'47 • 9 • 9	"	
Ruzickova, Hana	122	F	163.0	57.0	'41 • 2 • 18	"	
Sedlackova, Jaroslava	123	F	158.0	52.0	'46 • 6 • 21	"	
Tkacikova, Adolfina	124	F	154.0	50.0	'39 • 4 • 19	"	
Otahal, Zdenek	65	M	164.0	67.0	'36 • 1 • 31	Weight-Lifting Haltérophilie	Light
Zdrazil, Hans	91	M	169.0	75.0	'41 • 10 • 3	"	Middle
Kment, Petr		M	188.0	123.0	'42 • 8 • 20	Wrestling Lutte	Greco R.-Heavy
Kormanik, Jiri		M	178.0	87.0	'35 • 3 • 26	"	Greco R.-Middle
Kubat, Bohumil		M	185.0	123.0	'35 • 2 • 14	"	Free S.-Heavy
Svec, Jiri		M	162.0	57.0	'35 • 11 • 20	"	Greco R.-Bantam
Ferak, Ivàn		M	197.0	92.0	'41 • 12 • 18	Swimming and Diving Natation et Plongéons	200m Back
Lohnicky, Petr		M	176.0	70.0	'41 • 8 • 1	"	100m, 400m, 1500m Free
Vagner, Jindrich		M	184.0	85.0	'43 • 9 • 19	"	100 m Free
Falta, Ladislav	134	M	178.0	84.0	'36 • 1 • 30	Shooting Tir	Rapid Fire Pistol
Kudrna, Vladimir	132	M	183.0	112.0	'23 • 12 • 22	"	Free Pistol
Nacovsky, Lubomir	133	M	193.0	88.0	'35 • 5 • 26	"	Rapid Fire Pistol
Stiborik, Vladimir	131	M	170.0	75.0	'27 • 8 • 28	"	Free Rifle, Small Bore-3 P., Prone
Cuda, Milan	7	M	185.0	86.0	'39 • 9 • 22	Volley-Ball	
Golian, Bohumil	9	M	182.0	71.0	'31 • 3 • 25	"	
Humhal, Zdenek	3	M	191.0	83.0	'33 • 12 • 30	"	
Kop, Petr	6	M	190.0	86.0	'37 • 2 • 15	"	
Labuda, Josef	4	M	187.0	77.0	'41 • 12 • 31	"	
Musil, Josef	5	M	178.0	79.0	'32 • 7 • 3	"	
Paulus, Karel	8	M	173.0	77.0	'33 • 1 • 3	"	
Perusic, Boris	10	M	181.0	73.0	'40 • 7 • 27	"	
Schenk, Pavel	11	M	198.0	82.0	'41 • 6 • 27	"	

NAME NOM	NO. NO.	SEX SEXE	HEIGHT HAUTEUR	WEIGHT POIDS	DATE OF BIRTH DATE DE NAISSANCE	EVENT EPREUVE	
Smidl, Vaclav	1	M	192.0	84.0	'40 • 3 • 18	Volley-Ball	
Sorm, Josef	2	M	185.0	84.0	'32 • 3 • 2	"	
Toman, Ladislav	12	M	185.0	86.0	'34 • 7 • 13	"	
Vejvoda, Miroslav		M	184.0	82.0	'37 • 7 • 5	Yachting	Finn
DENMARK DANEMARK							
Andersen, Jette	37	F	167.0	54.0	'45 • 8 • 29	Athletics Athlétisme	800m
Dam, Jorgen Nielsen	93	M	176.0	58.0	'41 • 10 • 30	"	5000m
Hansen, Nina Ella Damkjar	38	F	167.0	56.0	'42 • 5 • 8	"	Long Jump, Pentathlon
Kristensen, Tommy	94	M	181.0	71.0	'39 • 11 • 6	"	20km Road Walk
Berendt, Jens		M	184.0	84.0	'40 • 2 • 21	Rowing Aviron	Pair, With Cox
Boye, Hans Jorgen		M	188.0	81.0	'43 • 6 • 30	"	Pair, Without Cox
Danning, Poul		M	173.0	68.0	'15 • 10 • 23	"	Reserve, Oarsmen
Fich Christiansen, Peter		M	180.0	80.0	'41 • 4 • 4	"	Pair, Without Cox
Haslov, Bjorn Borgen		M	182.0	81.5	'41 • 5 • 18	"	Four, Without Cox
Helmudt, Kurt		M	194.0	100.0	'43 • 12 • 7	"	Four, Without Cox
Hinsby, Tom		M	191.0	90.0	'45 • 7 • 22	"	Four, With Cox
Larsen, Bent		M	160.0	54.0	'42 • 8 • 31	"	Four, With Cox
Nielsen, Knud		M	183.0	78.0	'36 • 6 • 26	"	Pair, With Cox
Nielsen, Niels Johannes		M	182.0	80.0	'39 • 1 • 26	"	Four, With Cox
Nielsen, Poul Erik		M	184.0	81.0	'43 • 6 • 5	"	Four, With Cox
Olsen, Niels Alfred		M	155.0	46.0	'48 • 12 • 28	"	Pair, With Cox
Orsted Hansen, John		M	185.0	82.0	'38 • 10 • 8	"	Four, Without Cox
Paustian, Ole		M	184.0	80.0	'37 • 6 • 8	"	Four, With Cox
Petersen, Erik		M	184.0	81.0	'39 • 9 • 23	"	Four, Without Cox
Schmidt, Borge		M	176.0	73.0	'19 • 3 • 15	"	Reserve, Oarsmen
Bogs Tom Frank	75	M	176.0	72.0	'44 • 11 • 21	Boxing Boxe	L. Middle
Krogh, Borge	72	M	168.0	59.0	'42 • 4 • 2	"	Light
Pedersen, Hans-Erik	74	M	178.0	67.0	'43 • 12 • 10	"	Welter
Rasmussen, Preben R. S.	73	M	168.0	63.0	'41 • 11 • 14	"	L. Welter
Hansen, Birthe Lindskov	39	F	178.0	64.0	'44 • 6 • 8	Canoeing Canotage	Kayak 2
Hansen, Erik Rosendahl	40	M	183.0	79.0	'39 • 11 • 15	"	Kayak 1
Jensen, Preben Steen	41	M	180.0	75.0	'44 • 7 • 31	"	Kayak 2
Knudsen, Hans Wiggo	42	M	183.0	74.0	'44 • 8 • 11	"	Kayak 2
Norrbohm Nielsen, Peer	43	M	179.0	79.0	'42 • 6 • 25	"	Canadian 2
Sorensen, John Rungsted	44	M	170.0	66.0	'34 • 10 • 5	"	Canadian 2
Werner-Hansen, Anni Marie	45	F	162.0	62.0	'39 • 7 • 21	"	Kayak 1, 2
Fredborg, Niels Christian	42	M	176.0	76.0	'46 • 10 • 28	Cycling Cyclisme	Scratch, Tandem Sprint
Hansen, Bent Kurt	38	M	186.0	76.0	'32 • 10 • 21	"	Team Pursuit
Hansen, Flemming Gleerup	19	M	177.0	75.0	'44 • 2 • 11	"	Road Team T. T.
Ingstrup-Mikkelsen, Jan	44	M	180.0	71.0	'44 • 2 • 25	"	1000m T. T.
Isaksson, Preben	39	M	183.0	73.0	'43 • 1 • 22	"	Ind., Team Pursuit
Johansen, Alf	40	M	186.0	77.0	'44 • 4 • 10	"	Team Pursuit
Jorgensen, Per Sarto	43	M	174.0	72.0	'44 • 3 • 3	"	Tandem Sprint
Pedersen, Ole Hojlund	27	M	177.0	75.0	'43 • 2 • 17	"	Road Ind., Team T. T.
Pedersen, Peder	45	M	187.0	82.0	'45 • 11 • 3	"	Scratch Sprint
Petersen, Henning	26	M	180.0	77.0	'39 • 9 • 3	"	Road Ind., Team T. T.
Ritter, Ole P. J.	29	M	178.0	74.0	'41 • 8 • 29	"	Road Ind., Team T. T.
Rodian, Kiell Akerstrom	28	M	179.0	73.0	'42 • 6 • 30	"	Ind. Road.
Vid Stein, Kur	41	M	190.0	75.0	'35 • 11 • 17	"	Team Pursuit
Jensen, Jorgen Christian		M	158.0	51.0	'39 • 6 • 2	Wrestling Lutte	Greco R.-Fly
Madsen, Kurt Valter Lyngh		M	166.0	68.0	'36 • 1 • 8	"	Greco R.-Light
Skrydstrup, Svend Peter		M	163.0	61.0	'40 • 1 • 21	"	Greco R.-Feather
Kraus Jensen, Lars		M	184.0	80.0	'44 • 8 • 7	Swimming and Diving Natation et Plongeurs	200m Back
Michaelsen, Kirsten		F	168.0	58.0	'43 • 6 • 16	"	100m Back
Strange, Kirsten		F	176.0	64.0	'44 • 7 • 14	"	100m Free, 400m Ind. Medley
Svejstrup, Soren		M	179.0	77.0	'37 • 12 • 5	"	High Diving
Velin, Kirsten Bodil		F	170.0	59.0	'44 • 12 • 14	"	High Diving
Jensen, Ole C. H.	136	M	185.0	75.0	'33 • 11 • 5	Shooting Tir	Small Bore-3 P., Prone
Petersen, Niels Svend	135	M	182.0	87.0	'32 • 9 • 8	"	Small Bore-3 P., Prone

NAME NOM	NO. NO.	SEX SEXE	HEIGHT HAUTEUR	WEIGHT POIDS	DATE OF BIRTH DATE DE NAISSANCE	EVENT EPREUVE	
Berntsen, Ole V. H.		M	180.0	77.0	'15 • 1 • 22	Yachting	Dragon
Berntsen, William Eldred		M	170.0	70.0	'12 • 3 • 25	"	5.5m
Elvstrom, Baul Bert		M	182.0	85.0	'28 • 2 • 25	"	Reserve
Fogh, Hans Marius		M	170.0	71.0	'38 • 3 • 8	"	F. Dutchman
Holm, Axel		M	174.0	74.0	'07 • 11 • 15	"	Reserve
Holm, Per		M	178.0	79.0	'36 • 12 • 2	"	5.5m
Lassen, Aage C. C.		M	181.0	62.0	'43 • 1 • 9	"	5.5m
Petersen, Ole Erik Gunnar		M	176.0	75.0	'34 • 12 • 30	"	F. Dutchman
Poulsen, Ole		M	178.0	73.0	'41 • 12 • 16	"	Dragon
Von Bulow, Christian R.		M	173.0	72.5	'17 • 12 • 14	"	Dragon
Wind, Henning Norgaard		M	176.0	80.0	'37 • 1 • 19	"	Finn
Wolhardt, Jens Juul		M	179.0	83.0	'37 • 2 • 1	"	Reserve
DOMINICAN REPUBLIC REPUBLIQUE DOMINICAINE							
Torres Mota, Alberto S.	95	M	.	.	'34 • 2 • 20	Athletics Athlétisme	100m, 200m
ETHIOPIA ETHIOPIE							
Bezabih, Tegegn	96	M	180.0	65.0	'41 • 8 • 15	Athletics Athlétisme	200m, 400m
Bikila, Abebe	100	M	177.0	61.0	'32 • 8 • 7	"	Marathon
Mamo, Sebsibe	97	M	173.0	66.0	'44 • 9 • 24	"	800m, 1500m
Wolde, Demissie	99	M	165.0	53.0	'37 • 3 • 8	"	Marathon
Wolde, Mamo	98	M	170.0	56.0	'32 • 6 • 12	"	5000m, 10000m, Marathon
Alemou, Bekele	78	M	171.0	70.0	'41 • 12 • 15	Boxing Boxe	L. Middle
Guebre Giorgis, Tadesse	77	M	178.0	61.0	'38 • 2 • 12	"	L. Welter
Mekonen, Abebe	76	M	165.0	58.0	'40 • 9 • 23	"	Light
Ambaye, Solomon	30	M	165.0	57.0	'35 • 9 • 11	Cycling Cyclisme	Road Ind., Team T. T.
Guebreyesus, Fisihasion	31	M	168.0	58.0	'40 • 9 • 27	"	Road Ind., Team T. T.
Negassi, Yemane	32	M	167.0	54.0	'45 • 12 • 20	"	Road Ind., Team T. T.
Salimbeni, Mikael Karmelo	33	M	170.0	68.0	'40 • 11 • 22	"	Road Ind., Team T. T.
FINLAND FINLANDE							
Ankio, Risto Antero	108	M	184.0	75.0	'37 • 4 • 15	Athletics Athlétisme	Pole Vault
Eskola, Pentti Kalervo	109	M	182.0	83.0	'38 • 7 • 16	"	Long Jump
Hellen, Johan Henrik	105	M	182.0	72.0	'39 • 12 • 20	"	High Jump
Juutilainen, Pekka K.	101	M	190.0	70.0	'40 • 12 • 3	"	800m
Kaarina, Leena Kyllikki	40	F	182.0	72.0	'39 • 11 • 26	"	High Jump
Kinnunen, Jorma V. P.	112	M	175.0	75.0	'41 • 12 • 15	"	Javelin Throw
Laitinen, Taisto Raikas	106	M	182.0	74.0	'33 • 9 • 17	"	Pole Vault
Nevala, Pauli Lauri	111	M	178.0	80.0	'40 • 10 • 31	"	Javelin Throw
Nikula, Pentti Kustaa	107	M	179.0	70.0	'39 • 2 • 3	"	Pole Vault
Norrlund, Sirkka Matjatta	39	F	168.0	53.0	'43 • 3 • 8	"	80m Hurdles
Oksanen, Eino Ilmari	115	M	173.0	65.0	'31 • 5 • 7	"	Marathon
Pystynen, Paavo Kalervo	113	M	170.0	63.0	'32 • 2 • 3	"	Marathon
Repo, Pentti	110	M	184.0	94.0	'30 • 10 • 23	"	Discus Throw
Salonen, Olavi V. K.	102	M	174.0	74.0	'33 • 12 • 20	"	1500m
Saloranta, Simo, Sakari	103	M	179.0	81.0	'34 • 12 • 12	"	5000m
Tuominen, Jaakko A. U.	104	M	186.0	77.0	'44 • 5 • 4	"	400m Hurdles
Valle, Eino Olavi	114	M	171.0	62.0	'32 • 2 • 18	"	Marathon
Hanninen, Kauko		M	185.0	88.0	'30 • 1 • 28	Rowing Aviron	Pair, Without Cox Four, With Cox
Kanerva, Ismo		M	164.0	53.0	'42 • 6 • 3	"	Four, With Cox
Kesalainen, Teppo		M	183.0	81.0	'42 • 2 • 15	"	Four, With Cox
Lehtela, Veli		M	182.0	76.0	'35 • 9 • 6	"	Pair, Without Cox
Maisala, Mauno		M	178.0	80.0	'33 • 8 • 26	"	Four, With Cox
Pitkanen, Toimi		M	182.0	80.0	'28 • 5 • 23	"	Pair. Without Cox Four, With Cox
Sylvander, Pekka		M	186.0	95.0	'43 • 1 • 10	"	Four, With Cox
Finneman, Teijo Uolevi	14	M	182.0	70.0	'44 • 9 • 9	Basket-Ball	
Harjula, Juha Anton K.	10	M	191.0	70.0	'42 • 6 • 20	"	
Kala, Risto Antero	11	M	187.0	77.0	'41 • 7 • 24	"	
Kauppinen, Kauko Kalervo	12	M	187.0	78.0	'40 • 1 • 12	"	
Laanti, Pertti Juhani	7	M	195.0	80.0	'39 • 4 • 24	"	
Lampen, Timo Heikki E.	6	M	195.0	86.0	'34 • 9 • 5	"	
Liimo, Kari Tapani	5	M	198.0	91.0	'44 • 3 • 6	"	

NAME NOM	NO. NO.	SEX SEXE	HEIGHT HAUTEUR	WEIGHT POIDS	DATE OF BIRTH DATE DE NAISSANCE	EVENT EPREUVE
Liimo, Martti Juhani	8	M	193.0	84.0	'41 • 9 • 26	Basket-Ball
Lindholm, Raimo Allan	9	M	191.0	86.0	'32 • 11 • 17	"
Manninen, Uolevi	4	M	202.0	98.0	'37 • 4 • 7	"
Pilkevaara, Jorma Kalevi	13	M	186.0	81.0	'45 • 10 • 24	"
Vartia, Raimo Veikko	15	M	181.0	75.0	'37 • 1 • 15	"
Halonen, Tauno Antero	81	M	168.0	62.0	'38 • 12 • 15	Boxing Boxe
Karvonen, Boije Karl V.	79	M	169.0	55.0	'38 • 9 • 14	"
Limmonen, Jorma Johannes	80	M	168.0	59.0	'34 • 9 • 29	"
Mattsson, Kurt Antero	83	M	178.0	73.0	'40 • 3 • 1	"
Purhonen, Pertti Ilmari	82	M	181.0	69.0	'42 • 6 • 14	"
Makinen, Kari	46	M	180.0	76.0	'45 • 8 • 30	Canoeing Canotage
Narjanen, Rudolf	47	M	173.0	71.0	'41 • 3 • 31	"
Numisto, Ilkka Kalevi	48	M	185.0	84.0	'44 • 4 • 24	"
Ekman, Eugen, Georg, O.	103	M	178.0	71.0	'37 • 10 • 27	Gymnastics Gymnastique
Heikkinen, Kauko P. J.	106	M	177.0	66.0	'38 • 3 • 3	"
Heinonen, Raimo Yrjo	104	M	174.0	66.0	'35 • 5 • 29	"
Kestola, Ottojalmar	105	M	172.0	60.0	'36 • 5 • 20	"
Koskinen, Salme Kaarina	113	F	172.0	56.0	'44 • 4 • 20	"
Laiho, Olli Eino	101	M	175.0	69.0	'43 • 2 • 18	"
Lehtonen, Eira Marita	112	F	159.0	53.0	'31 • 9 • 22	"
Olkkonen, Sakari E. E.	107	M	168.0	66.0	'31 • 1 • 15	"
Rantakari, Hannu Juhani	102	M	172.0	66.0	'39 • 1 • 8	"
Kailajarvi, Jaakko Rafael	113	M	170.0	82.5	'41 • 7 • 1	Weight-Lifting Haltérophilie
Kailajarvi, Jouni Kalervo	135	M	170.0	90.0	'38 • 6 • 4	"
Kangasniemi, Kaarlo Olavi	114	M	174.0	82.5	'41 • 1 • 4	"
Makinen, Eino Matias	156	M	183.0	118.0	'26 • 6 • 13	"
Alanen, Pekka Ahti	M	M	170.0	59.0	'45 • 7 • 14	Wrestling Lutte
Bjorlin, Risto	M	M	168.0	55.0	'44 • 12 • 9	"
Jaskari, Tauno Antero	M	M	167.0	63.0	'34 • 7 • 1	"
Kangasniemi, Taisto I.	M	M	186.0	110.0	'24 • 4 • 2	"
Laakso, Matti Samuel	M	M	177.0	79.0	'39 • 3 • 23	"
Lehtonen, Kyosti Emil	M	M	165.0	67.0	'31 • 3 • 13	"
Maenpaa, Aimo Matias	M	M	181.0	99.0	'37 • 1 • 30	"
Punkari, Pentti Tuomas	M	M	175.0	87.0	'38 • 1 • 12	"
Savolainen, Arto	M	M	175.0	74.0	'41 • 2 • 3	"
Tapio, Eero Johannes	M	M	170.0	73.0	'41 • 3 • 3	"
Hamalainen, Tuomo Juhani	M	M	187.0	83.0	'45 • 3 • 4	Swimming and Diving Natation et Plongeurs
Kasvio, Matti Juhani	M	M	189.0	80.0	'44 • 2 • 20	"
Koskinen, Pentti P. I.	M	M	168.0	60.0	'43 • 7 • 24	"
Lepola, Esa Olavi	M	M	182.0	66.0	'48 • 9 • 25	"
Pyrhonen, Eila Marjatta	F	F	177.0	74.0	'45 • 10 • 25	"
Suvanto, Ilkka T.	M	M	182.0	80.0	'43 • 8 • 13	"
Vaahstoranta, H. Pertti J.	M	M	177.0	75.0	'43 • 5 • 20	"
Aho, Seppo Risto	14	M	174.0	68.0	'44 • 3 • 7	Modern Pentathlon Pentathlon Moderne
Hotanen, Jorma Olavi	15	M	178.0	70.0	'36 • 9 • 15	"
Kaaja, Kari Juhani	16	M	174.0	71.0	'41 • 4 • 6	"
Vanhala, Keijo K.V.	17	M	187.0	76.0	'40 • 7 • 7	"
Huhtinen, Immo Uolevi	142	M	165.0	65.0	'32 • 8 • 30	Shooting Tir
Kervinen, Esa Einari	138	M	170.0	75.0	'29 • 12 • 26	"
Koskinen, Antti Kalervo	139	M	173.0	75.0	'29 • 4 • 21	"
Linnoavuop, Pentti Tapio	143	M	182.0	79.0	'33 • 3 • 17	"
Markkanen, Vaino Johannes	141	M	170.0	67.0	'29 • 5 • 9	"
Rissanen, Antti	137	M	170.0	67.0	'31 • 4 • 28	"
Sievanen, Kalle Emil	144	M	170.0	57.0	'11 • 3 • 9	"
Ylonen, Vilho Ilmari	140	M	169.0	67.0	'18 • 5 • 3	"
Fazer, Karl Peter	M	M	182.0	85.0	'34 • 10 • 23	Yachting
Gullichsen, Johan Erik	M	M	187.0	78.0	'36 • 6 • 28	"
Gullichsen, Kristian	M	M	188.0	70.0	'32 • 9 • 29	"
Salovaara, Juhani Richard	M	M	174.0	65.0	'31 • 11 • 4	"

NAME NOM	NO. NO.	SEX SEXE	HEIGHT HAUTEUR	WEIGHT POIDS	DATE OF BIRTH DATE DE NAISSANCE	EVENT EPREUVE	
Tallberg, Henrik Julius		M	180.0	79.0	'42 • 7 • 3	Yachting	Star
Tallberg, Peter Julius		M	178.0	82.0	'37 • 7 • 15	"	Star
FRANCE FRANCE							
Bambuck, Roger	116	M	182.0	75.0	'45 • 11 • 22	Athletics Athlétisme	100m, 200m, 4X100m
Battista, Eric	144	M	171.0	68.0	'33 • 5 • 14	"	Triple Jump
Bchm, Jean-Jacques	131	M	185.0	76.0	'42 • 5 • 14	"	400m Hurdles
Bernard, Michel	126	M	181.0	70.0	'31 • 12 • 31	"	1500m
Boccardo, Jean Pierre	121	M	188.0	72.0	'42 • 3 • 10	"	400m, 400m Hurdles, 4X400m
Brugier, Jean Louis	147	M	.	.	'39 • 11 • 8	"	Marathon
Cadic, Christiane	41	F	164.0	60.0	'47 • 1 • 8	"	100m, 4X100m
Camboulives, Michel	134	M	173.0	68.0	'39 • 7 • 6	"	4X100m
Canguio, Marlene	46	F	171.0	70.0	'42 • 3 • 10	"	80m Hurdles, 4X100m
Chatelet, Francis	123	M	174.0	68.0	'39 • 2 • 27	"	800m
Cochard, Jean	143	M	190.0	87.0	'39 • 3 • 27	"	Long Jump
D'Encausse, Herve	140	M	180.0	70.0	'45 • 9 • 27	"	Pole Vault
Defevre, Alain	142	M	181.0	68.0	'42 • 7 • 4	"	Long Jump
Delecour, Jocelyn	119	M	175.0	68.0	'35 • 1 • 2	"	200m, 4X100m
Delerue, Henri	148	M	169.0	67.0	'39 • 11 • 14	"	20km, 50km Road Walk
Demys, Michele	48	F	176.0	72.0	'43 • 9 • 16	"	Javelin Throw
Dupureur, Maryvonne	45	F	167.0	55.0	'37 • 5 • 24	"	800m
Duriez, Marcel	129	M	189.0	86.0	'40 • 6 • 20	"	110m Hurdles
Fayolle, Jean	127	M	170.0	62.0	'37 • 11 • 10	"	5000m, 10000m
Fournet, Bernard	130	M	182.0	68.0	'41 • 12 • 13	"	110m Hurdles
Genevay, Paul	120	M	177.0	74.0	'39 • 1 • 21	"	200m, 4X100m
Guenard, Denise	47	F	168.0	62.0	'34 • 1 • 13	"	80m Hurdles, 4X100m
Gueneau, Daniele	42	F	164.0	59.0	'47 • 8 • 31	"	Pentathlon 100m, 4X100m
Hiblot, Michel	135	M	174.0	60.0	'43 • 4 • 19	"	4X400m
Houvion, Maurice	141	M	176.0	72.0	'34 • 7 • 4	"	Pole Vault
Husson, Guy	146	M	183.0	108.0	'31 • 3 • 2	"	Hammer Throw
Jazy, Michel	124	M	176.0	66.0	'36 • 6 • 13	"	1500m, 5000m
Laidebeur, Bernard	117	M	180.0	75.0	'42 • 7 • 11	"	100m, 4X100m
Lebret, Evelyne	44	F	172.0	70.0	'39 • 2 • 20	"	400m, 4X100m
Lurot, Maurice	122	M	179.0	66.0	'40 • 4 • 13	"	800m
Lurot, Michele	43	F	161.0	63.0	'43 • 4 • 15	"	200m, 4X100m
Macquet, Michel	145	M	181.0	96.0	'32 • 4 • 3	"	Javelin Throw
Martin, Bernard	137	M	183.0	80.0	'43 • 2 • 19	"	4X400m
Nelzy, Germain	138	M	180.0	75.0	'34 • 8 • 3	"	4X400m
Piquemal, Claude	118	M	172.0	65.0	'39 • 3 • 13	"	100m, 4X100m
Poirier, Robert	132	M	181.0	70.0	'42 • 6 • 14	"	400m Hurdles, 4X400m
Sainte Rose, Robert	139	M	191.0	80.0	'43 • 7 • 5	"	High Jump
Samper, Michel	136	M	182.0	68.0	'43 • 5 • 1	"	4X400m
Texereau, Guy	133	M	166.0	56.0	'35 • 5 • 14	"	3000m S. C.
Vaillant, Jean	128	M	178.0	62.0	'32 • 4 • 23	"	5000m, 10000m
Wadoux, Jean	125	M	180.0	60.0	'42 • 1 • 29	"	1500m
Bouffard-Barreur, Alain		M	165.0	52.0	'39 • 9 • 24	Rowing Aviron	Eight, With Cox
Chatelain, Roger		M	186.0	82.0	'42 • 4 • 23	"	Four, Without Cox
Clerc, Emile		M	185.0	75.0	'34 • 6 • 5	"	Four, Without Cox
Darouy, Jean Claude		M	165.0	52.0	'44 • 8 • 30	"	Pair, Four, With Cox
Drivet, Jean Pierre		M	183.0	82.0	'42 • 4 • 2	"	Four, Without Cox
Duhamel, Rene		M	183.0	80.0	'35 • 2 • 1	"	Double Sculls
Dumas, Michel		M	186.0	82.0	'44 • 10 • 19	"	Four, With Cox
Dumontois, Robert		M	192.0	90.0	'41 • 8 • 6	"	Eight, With Cox
Fevret, Andre		M	176.0	76.0	'41 • 10 • 24	"	Eight, With Cox
Fraisse, Yves		M	183.0	78.0	'43 • 11 • 14	"	Four, With Cox
Freslon, Francois		M	182.0	81.0	'45 • 6 • 15	"	Reserve, Cox
Grimaud, Jean Pierre		M	185.0	83.0	'44 • 3 • 23	"	Eight, With Cox
Jacquesson, Gerard		M	187.0	82.0	'41 • 8 • 30	"	Four, With Cox
Maddaloni, Pierre		M	183.0	82.0	'41 • 6 • 23	"	Eight, With Cox
Malivoir, Philippe		M	180.0	78.0	'42 • 8 • 7	"	Four, Without Cox

NAME NOM	NO. NO.	SEX SEXE	HEIGHT HAUTEUR	WEIGHT POIDS	DATE OF BIRTH DATE DE NAISSANCE	EVENT EPREUVE
Mevnadier, Bernard		M	186.0	85.0	'38 • 4 • 19	Rowing Aviron
Monnerneau, Eernard		M	178.0	75.0	'35 • 9 • 18	"
Morel, Georges		M	188.0	92.0	'38 • 7 • 11	"
Morel, Jacques		M	193.0	85.0	'35 • 9 • 22	"
Moroni, Joseph		M	184.0	85.0	'38 • 1 • 10	"
Pache, Claude		M	183.0	82.0	'43 • 1 • 5	"
Sloth, Andre		M	194.0	85.0	'44 • 5 • 20	"
Viaud, Michel		M	186.0	82.0	'40 • 2 • 15	"
Cotot, Jacques	86	M	166.0	60.0	'40 • 8 • 11	Boxing Boxe
Gonzales, Joseph	87	M	173.0	71.0	'40 • 8 • 6	"
Marty, Jacques	88	M	178.0	75.0	'40 • 7 • 30	"
Thebault, Bernard	89	M	178.0	81.0	'43 • 1 • 10	"
Vandomme, Marc	84	M	.	.	'44 • 4 • 27	"
Vermandere, Daniel	85	M	.	.	'43 • 2 • 6	"
Boudehen, Jean	49	M	175.0	70.0	'39 • 1 • 11	Canoeing Canotage
Chapuis, Michel	50	M	176.0	69.0	'41 • 6 • 18	"
Aimar, Lucien	34	M	170.0	.	'41 • 4 • 28	Cycling Cyclisme
Bazire, Francis Augustin	35	M	169.0	.	'39 • 4 • 17	"
Bidault, Marcel-Ernest	50	M	176.0	.	'38 • 5 • 11	"
Boudringhin, Jacques	46	M	.	.	'45 • 5 • 11	"
Chappe, Georgez	51	M	182.0	.	'44 • 3 • 5	"
Cuch, Christian	47	M	.	.	'43 • 10 • 25	"
Desvages, Andre J. L.	53	M	184.0	.	'44 • 3 • 12	"
Fix, Daniel	52	M	.	.	'44 • 12 • 28	"
Guyot, Bernard	36	M	.	.	'45 • 11 • 19	"
Morelon, Daniel	54	M	.	.	'44 • 7 • 24	"
Pare, Joseph	48	M	.	.	'43 • 12 • 30	"
Raymond, Christian	37	M	178.0	.	'43 • 12 • 24	"
Suire, Jacques	49	M	.	.	'43 • 2 • 18	"
Trentin, Pierre	56	M	.	.	'44 • 5 • 15	"
Varga, Robert	57	M	.	.	'41 • 9 • 23	"
Wuillemin, Jean-Claude R.	55	M	180.0	.	'43 • 6 • 22	"
Arabo, Claude	81	M	178.0	76.0	'37 • 10 • 3	Fencing Escrime
Bourquard, Claude	76	M	173.0	70.0	'37 • 3 • 5	"
Brodin, Claude	77	M	170.0	61.0	'34 • 7 • 20	"
Brodin, Jacques	78	M	175.0	71.0	'46 • 12 • 22	"
Courtilat, Jacky	71	M	171.0	68.0	'43 • 1 • 8	"
Depetris, Marie Chantai	66	F	162.0	52.0	'41 • 12 • 17	"
Dreyfus, Yves	79	M	178.0	70.0	'31 • 6 • 17	"
Fraisse, Robert	82	M	184.0	84.0	'34 • 4 • 12	"
Gapais, Brigitte	67	F	163.0	57.0	'44 • 4 • 25	"
Guittet, Jack	80	M	183.0	65.0	'30 • 1 • 20	"
Lefevre, Jacques	83	M	176.0	72.0	'28 • 2 • 1	"
Level, Annick	68	F	165.0	66.0	'42 • 12 • 5	"
Magnan, Jean Claude	72	M	181.0	76.0	'41 • 6 • 4	"
Noel, Christian	73	M	184.0	74.0	'45 • 3 • 13	"
Parent, Marcel	84	M	172.0	62.0	'34 • 10 • 25	"
Ramez, Jean	85	M	181.0	82.0	'32 • 5 • 15	"
Revenu, Colette	69	F	166.0	58.0	'44 • 9 • 14	"
Revenu, Daniel	74	M	186.0	79.0	'42 • 12 • 5	"
Rodocanachi, Pierre	75	M	170.0	70.0	'38 • 10 • 2	"
Rousselet, Catherine	70	F	169.0	60.0	'43 • 5 • 17	"
Baelden, Monique	54	F	162.0	56.0	'38 • 4 • 10	Gymnastics Gymnastique
Bouchonnet, Michel	141	M	170.0	67.0	'40 • 7 • 17	"
Brisepierre, Jacqueline	55	F	167.0	59.0	'45 • 10 • 30	"
Coulon, Daniele		F	160.0	55.0	'35 • 3 • 24	"
Fauqueux, Bernard	142	M	166.0	62.0	'38 • 9 • 2	"
Guiffroy, Christian	143	M	166.0	60.0	'41 • 1 • 21	"
Letourneur, Evelyne	56	F	165.0	55.0	'47 • 9 • 13	"

NAME NOM	NO. NO.	SEX SEXE	HEIGHT HAUTEUR	WEIGHT POIDS	DATE OF BIRTH DATE DE NAISSANCE	EVENT EPREUVE	
Maier, Rolf	81	M	163.0	75.0	'36 • 12 • 16	Weight-Lifting Halterophilie	Middle
Paterni, Marcel	115	M	163.0	81.5	'36 • 9 • 22	"	L. Heavy
Bourreau, Andre		M	164.0	68.0	'34 • 12 • 3	Judo	Light
Grossain, Lionel		M	178.0	80.0	'38 • 2 • 12	"	Middle
Le Berre, Jacques		M	179.0	80.0	'37 • 9 • 21	"	Middle
Lesturgeon, Gaston M.		M	172.0	68.0	'36 • 11 • 30	"	Light
Ballery, Georges		M	168.0	63.0	'37 • 7 • 18	Wrestling Lutte	Free S., Greco R.-Feather
Sauton Dit Robin, Daniel		M	175.0	.	'43 • 5 • 31	"	Free S., Greco R.-Light
Schiermeyer, Rene		M	179.0	78.0	'38 • 9 • 27	"	Free S., Greco R.-Welter
Zoete, Andre		M	155.0	52.0	'31 • 8 • 30	"	Free S., Greco R.-Fly
Borie, Françoise		F	178.0	60.0	'47 • 2 • 16	Swimming and Diving Natation et Plongeurs	100m Back
Canavese, Pierre		M	178.0	70.0	'45 • 9 • 10	"	400m, 4X100m, 4X200m Free
Caron, Christine		F	170.0	61.0	'48 • 7 • 10	"	100m Back
Christophe, Robert		M	118.0	84.0	'38 • 2 • 22	"	200m Back, 4X100m, 4X200m Free
Curtillet, Jean Pascal		M	184.0	75.0	'42 • 9 • 21	"	100m, 4X100m, 4X200m Free
Duchateau, Pierre		M	176.0	75.0	'41 • 2 • 3	"	1500m Free
Gottvalles, Alain		M	186.0	82.0	'42 • 3 • 22	"	100m, 4X100m, 4X200m Free
Gropaiz, Gerard		M	183.0	70.0	'43 • 8 • 1	"	100m, 4X100m Free
Luyce, Francis		M	178.0	78.0	'47 • 2 • 13	"	400m, 4X200m Free
Pietri, Monique		F	170.0	60.0	'45 • 4 • 20	"	100m, 400m Free
Pommat, Jean		M	175.0	72.0	'44 • 8 • 30	"	400m Free, 200m Butterfly
De Croutte De St. Martin, J.		M	170.0	72.0	'32 • 9 • 16	Equestrian Sports Sport Equestre	Three-Day Event
Jonquieres D'Oriola, P.		M	173.0	70.0	'20 • 2 • 1	"	Jumping Grand Prix
Landon, Hugues		M	178.0	72.0	'30 • 6 • 26	"	Three-Day Event
Le Goff, J. L. J.		M	182.0	72.0	'31 • 4 • 8	"	Three-Day Event
Le Goupil, Andre		M	187.0	75.0	'31 • 1 • 7	"	Three-Day Event
Le Roy, Jehan		M	173.0	62.0	'23 • 11 • 5	"	Three-Day Event
Lefevre, Janou		F	165.0	59.0	'45 • 5 • 14	"	Jumping Grand Prix
Lefrant, Guy		M	169.0	70.0	'23 • 2 • 26	"	Jumping Grand Prix
Foussier Claude	15	M	190.0	99.0	'25 • 4 • 19	Shooting Tir	Clay Pigeon
Guy, Pierre	145	M	182.0	83.0	'31 • 8 • 5	"	Small Bore-Prone
Prevost, Michel	16	M	180.0	83.0	'25 • 8 • 7	"	Clay Pigeon
Renaux, Jean	146	M	174.0	89.0	'33 • 6 • 25	"	Free, Rapid Fire Pistol
Buffet, Marcel-Andre		M	181.0	75.0	'22 • 5 • 15	Yachting	F. Dutchman
Devillard, Gerard		M	183.0	75.0	'40 • 2 • 5	"	Finn
Harinkouck, Philippe		M	181.0	81.0	'27 • 12 • 28	"	Reserve
Lehoerff, Alain-Francois		M	189.0	89.0	'41 • 5 • 21	"	F. Dutchman
GERMANY ALLEMAGNE							
Balzer, Karin	78	F	171.0	60.0	'38 • 6 • 5	Athletics Athlétisme	80m Hurdles
Becker, Ingrid	88	F	178.0	63.0	'42 • 9 • 26	"	Long Jump, Pentathlon
Beer, Klaus	236	M	176.0	70.0	'42 • 11 • 14	"	Long Jump
Berger, Rainer	223	M	182.0	73.0	'44 • 9 • 23	"	4X100m
Beyer, Horst	262	M	196.0	92.0	'40 • 1 • 5	"	Decathlon
Beyer, Uwe	251	M	188.0	88.0	'45 • 4 • 14	"	Hammer Throw
Birlenbach, Heinfried	244	M	204.0	110.0	'40 • 12 • 7	"	Shot Put
Bogatzki, Dieter	203	M	185.0	89.0	'42 • 1 • 25	"	800m
Buscher, Margret	73	F	168.0	62.0	'38 • 2 • 8	"	400m
Diel, Gundula	79	F	172.0	67.0	'41 • 5 • 13	"	80m Hurdles
Doring, Fred	220	M	180.0	71.0	'33 • 2 • 7	"	3000m S. C.
Dorner, Rainer	221	M	175.0	64.5	'37 • 8 • 28	"	3000m S. C.
Drecoll, Ralf	231	M	185.0	80.0	'44 • 9 • 29	"	High Jump
Erbstosser, Heinz	197	M	175.0	72.0	'40 • 3 • 14	"	200m, 4X100m
Fahsl, Hans	252	M	191.0	102.5	'41 • 8 • 15	"	Hammer Throw
Falgowski, Dietmar	224	M	176.0	73.0	'41 • 1 • 25	"	4X100m
Frisch, Karin	82	F	172.0	61.0	'41 • 1 • 17	"	4X100m
Garisch-Culmberger, R.	90	F	175.0	98.0	'39 • 1 • 24	"	Shot Put
Gerhards, Anneliese	98	F	177.0	74.0	'35 • 7 • 4	"	Javelin Throw
Gieseler, Horst	219	M	182.0	70.0	'42 • 4 • 29	"	400m Hurdles
Gleichfeld, Antje	76	F	178.0	67.0	'38 • 3 • 31	"	800m

NAME NOM	NO. NO.	SEX SEXE	HEIGHT HAUTEUR	WEIGHT POIDS	DATE OF BIRTH DATE DE NAISSANCE	EVENT EPREUVE	
Haas, Ferdinand	218	M	180.0	70.0	'40 • 1 • 13	Athletics	400m Hurdles
Hagen, Heinrich	253	M	172.0	58.0	'35 • 12 • 7	Athletisme	Marathon
Hannemann, Artur	211	M	177.0	60.0	'35 • 10 • 23	"	10000m
Hartmann, Dieter	222	M	172.0	65.0	'38 • 1 • 24	"	3000m S. C.
Heine, Jutta	71	F	180.0	70.0	'40 • 9 • 16	"	200m, 4X100m
Helmbold, Margitta	92	F	175.0	79.0	'41 • 6 • 29	"	Shot Put
Herings, Rolf	247	M	181.0	84.0	'40 • 7 • 10	"	Javelin Throw
Herrmann, Siegfried	212	M	175.0	66.0	'32 • 11 • 17	"	10000m
Hinze, Manfred	239	M	171.0	67.5	'33 • 1 • 8	"	Triple Jump
Hoffmann, Dieter	242	M	187.0	109.0	'41 • 8 • 27	"	Shot Put
Hoffmann, Helga	89	F	168.0	61.0	'37 • 9 • 24	"	Long Jump, Pentathlon
Hohne Christoph	259	M	170.0	62.0	'41 • 2 • 12	"	50km Road Walk
Holdorf, Willi	263	M	182.0	90.0	'40 • 2 • 17	"	Decathlon
Holtz, Wolf-Dieter	205	M	186.0	72.5	'41 • 12 • 10	"	1500m
Honicke, Gerhard	254	M	174.0	65.0	'30 • 3 • 25	"	Marathon
Hubner, Johanna	91	F	175.0	83.0	'36 • 3 • 20	"	Shot Put
Jacob, Heilwig	68	F	166.0	59.0	'42 • 7 • 4	"	100m, 200m
John, Heinrich	215	M	183.0	73.0	'36 • 5 • 11	"	110m Hurdles
Juttner, Jorg	199	M	183.0	76.0	41 • 9 • 16	"	400m, 4X400m
Kalfelder, Jurgen	200	M	186.0	87.0	'40 • 9 • 27	"	400m, 4X400m
Kaufmann, Waltraud	75	F	161.0	55.0	'42 • 3 • 10	"	800m
Kinder, Manfred	204	M	184.0	75.0	'38 • 4 • 20	"	800m, 4X400m
Klein, Wolfgang	238	M	180.0	75.0	'41 • 1 • 28	"	Long Jump
Knickenberg, Manfred	194	M	176.0	72.0	'37 • 8 • 26	"	100m
Kopp, Zenta	80	F	175.0	63.0	'33 • 12 • 29	"	80m Hurdles
Koppen, Rudolf	230	M	185.0	80.0	'43 • 2 • 5	"	High Jump
Krebs, Wolfgang	225	M	176.0	68.5	'42 • 10 • 18	"	4X100m
Krivec, Gunter	241	M	175.0	68.0	'42 • 7 • 28	"	Triple Jump
Kuehl, Fritz	838	M	188.0	108.0	'35 • 5 • 7	"	Discus Throw
Kupferschmied, Gerda	84	F	172.0	65.0	'42 • 8 • 19	"	High Jump
Langer, Doris	85	F	173.0	58.0	'38 • 9 • 29	"	High Jump
Langer, Rudolf	243	M	191.0	105.0	'39 • 3 • 29	"	Shot Put
Laufer, Hildrun	87	F	172.0	65.0	'39 • 5 • 13	"	Long Jump, Pentathlon
Lehnertz, Klaus	234	M	185.0	72.0	'38 • 4 • 13	"	Pole Vault
Letzerich, Manfred	208	M	179.0	63.0	'42 • 8 • 15	"	5000m
Leuschke, Burkhard	260	M	183.0	65.0	'40 • 4 • 27	"	50km Road Walk
Limberg, Kriemhild	95	F	178.0	68.0	'34 • 9 • 8	"	Discus Throw
Lindner, Dieter	256	M	174.0	66.0	'37 • 1 • 18	"	20km Road Walk
Loffler, Volker	226	M	171.0	68.0	'42 • 6 • 27	"	4X100m
Lorenz, Doris	93	F	173.0	68.0	'35 • 2 • 25	"	Discus Throw
Losch, Hartmut	245	M	196.0	105.0	'43 • 9 • 11	"	Discus Throw
Lotz, Ingrid	94	F	169.0	73.0	'34 • 3 • 11	"	Discus Throw
Lotz, Martin	250	M	191.0	93.0	'38 • 5 • 28	"	Hammer Throw
Maisack, Erna	74	F	166.0	56.0	'41 • 10 • 13	"	400m
Matuschewski, Manfred	202	M	176.0	65.0	'39 • 9 • 2	"	800m
May, Jurgen	206	M	176.0	66.0	'42 • 6 • 18	"	1500m
Meyer, Renate	69	F	167.0	52.0	'38 • 1 • 6	"	100m, 4X100m
Milde, Lothar	246	M	195.0	102.0	'34 • 11 • 8	"	Discus Throw
Naumann, Manfred	255	M	175.0	66.0	'33 • 6 • 21	"	Marathon
Norpoth, Harald	209	M	184.0	61.5	'42 • 8 • 22	"	5000m
Obersiebrasse, Fritz	195	M	184.0	83.0	'40 • 10 • 30	"	100m
Pensberger, Martha	83	F	160.0	56.0	'41 • 5 • 22	"	4X100m
Philipp, Lutz	210	M	177.0	67.5	'40 • 10 • 14	"	5000m
Pollmann, Erika	70	F	168.0	55.0	'44 • 2 • 15	"	100m, 200m, 4X100m
Preussger, Manfred	233	M	178.0	75.0	'32 • 7 • 10	"	Pole Vault
Reimann, Hans-Georg	257	M	180.0	63.0	'41 • 8 • 24	"	20km Road Walk
Reinhardt, Wolfgang	235	M	179.0	69.0	'43 • 5 • 6	"	Pole Vault
Roderfeld, Friedrich	198	M	184.0	72.0	'43 • 7 • 31	"	200m
Rothe, Siegfried	213	M	169.0	59.0	'38 • 1 • 18	"	10000m

NAME NOM	NO. NO.	SEX SEXE	HEIGHT HAUTEUR	WEIGHT POIDS	DATE OF BIRTH DATE DE NAISSANCE	EVENT EPREUVE	
Ruckborn, Hans-Jurgen	240	M	190.0	80.0	'40 • 10 • 8	Athletics Athlétisme	Triple Jump
Ruger, Karin	86	F	182.0	80.0	'44 • 4 • 1	"	High Jump
Sakowski, Kurt	261	M	185.0	68.0	'30 • 12 • 23	"	50km Road Walk
Salomon, Hermann	248	M	183.0	82.5	'38 • 4 • 13	"	Javelin Throw
Schenk, Hans	249	M	185.0	85.0	'36 • 1 • 1	"	Javelin Throw
Schillkowski, Wolfgang	232	M	178.0	69.5	'42 • 7 • 3	"	High Jump
Schmidt, Gertrud	72	F	162.0	57.0	'42 • 7 • 18	"	400m
Schmitt, Johannes	201	M	179.0	67.0	'43 • 2 • 18	"	400m, 4X400m
Schubert, Rosemarie	96	F	170.0	61.0	'43 • 11 • 7	"	Javelin Throw
Schulz, Hans-Ulrich	228	M	184.0	33.0	'39 • 5 • 24	"	4X400m
Schumann, Heinz	196	M	179.0	76.0	'36 • 8 • 6	"	100m, 200m
Schwalbe, Ingeborg	97	F	166.0	72.0	'35 • 11 • 21	"	Javelin Throw
Singer, Joachim	217	M	176.0	70.0	'42 • 11 • 5	"	400m Hurdles
Sperling, Gerhard	258	M	187.0	74.0	'37 • 11 • 15	"	20km Road Walk
Stock, Jutta	81	F	176.0	59.0	'41 • 9 • 29	"	4X100m
Trense, Hans-Helmut	237	M	187.0	84.0	'40 • 8 • 17	"	Long Jump
Trzmiel, Werner	216	M	183.0	74.0	'42 • 3 • 16	"	110m Hurdles
Valentin, Siegfried	207	M	174.0	64.0	'36 • 2 • 23	"	1500m
Voigt, Christian	214	M	187.0	78.0	'43 • 12 • 20	"	110m Hurdles
Walde, Hans-Joachim	264	M	190.0	90.0	'42 • 6 • 28	"	Decathlon
Wallach, Peter	227	M	178.0	72.0	'38 • 10 • 30	"	4X100m
Weiland, Wilfried	229	M	181.0	73.0	'44 • 1 • 18	"	4X400m
Worner, A Nita	77	F	175.0	65.0	'42 • 2 • 24	"	800m
Aeffke, Klaus	M	189.0	82.0	'40 • 5 • 9	Rowing Aviron	Eight, With Cox	
Ahrens, Thomas	M	163.0	50.0	'48 • 5 • 27	"	Eight, With Cox	
Behrens, Klaus	M	191.0	88.0	'41 • 8 • 3	"	Eight, With Cox	
Bender, Dieter	M	187.0	92.0	'40 • 5 • 19	"	Four, With Cox	
Bergau, Gunter	M	185.0	88.0	'39 • 4 • 11	"	Pair, With Cox	
Bittner, Klaus	M	190.0	80.0	'38 • 10 • 23	"	Eight, With Cox	
Bothe, Heinz-Jurgen	M	191.0	86.0	'41 • 11 • 5	"	Single Sculls, Pair, With Cox	
Britting, Bernhard	M	189.0	88.0	'40 • 10 • 22	"	Four With Cox	
Danielowski, Karl-Heinz	M	166.0	50.0	'40 • 3 • 31	"	Pair, With Cox	
Effertz, Horst	M	194.0	93.0	'38 • 8 • 4	"	Four, Without Cox	
Gorny, Peter	M	189.0	85.0	'41 • 4 • 20	"	Pair, With Cox	
Hill, Achim	M	185.0	81.0	'35 • 4 • 1	"	Single Sculls	
Hirschfelder, Egbert	M	196.0	93.0	'42 • 7 • 13	"	Four, With Cox	
Hottenrott, Wolfgang	M	193.0	92.0	'40 • 6 • 13	"	Pair, Without Cox	
Jordan, Klaus-Gunter	M	195.0	95.0	'40 • 9 • 17	"	Eight, With Cox	
Lebert, Helmut	M	188.0	83.0	'41 • 2 • 18	"	Double Sculls	
Meyer, Horst	M	184.0	84.0	'41 • 6 • 20	"	Eight, With Cox	
Misselhorn, Manfred	M	189.0	84.0	'38 • 7 • 29	"	Four, Without Cox	
Muller, Albrecht	M	190.0	94.0	'38 • 11 • 4	"	Four, Without Cox	
Neusel, Peter	M	193.0	94.0	'40 • 11 • 19	"	Four, With Cox	
Oelke, Jurgen	M	170.0	55.0	'40 • 11 • 25	"	Four, With Cox	
Plagemann, Jurgen	M	182.0	77.0	'36 • 12 • 28	"	Eight, With Cox	
Schmidt, Peter	M	178.0	82.0	'39 • 12 • 6	"	Eight, With Cox	
Schroeder, Jurgen	M	191.0	94.0	'40 • 3 • 6	"	Eight, With Cox	
Schroers, Gunter	M	187.0	82.0	'39 • 1 • 11	"	Four, Without Cox	
Schulz, Helmut	M	190.0	85.0	'39 • 2 • 8	"	Four, Without Cox	
Schwan, Michael	M	187.0	87.0	'39 • 11 • 5	"	Pair, Without Cox	
Steffes-Mies, Josef	M	195.0	91.0	'40 • 5 • 13	"	Double Sculls	
Von Groddeck, Karl-II	M	191.0	90.0	'36 • 7 • 19	"	Eight, With Cox	
Wallbrecht, Hans-Jurgen	M	187.0	93.0	'43 • 8 • 8	"	Eight, With Cox	
Werner, Joachim	M	190.0	89.0	'39 • 7 • 19	"	Four, With Cox	
Wolter, Gerd	M	192.0	82.0	'39 • 5 • 22	"	Double Sculls	
Babiasch, Otto	90	M	161.0	51.0	'37 • 3 • 21	Boxing Boxe	Fly
Guse, Bruno	95	M	170.0	67.0	'39 • 7 • 13	"	Welter
Hogh, Paul	96	M	176.0	71.0	'33 • 8 • 1	"	L. Middle
Huber Hans	99	M	194.0	96.0	'34 • 1 • 1	"	Heavy

NAME NOM	NO. NO.	SEX SEXE	HEIGHT HAUTEUR	WEIGHT POIDS	DATE OF BIRTH DATE DE NAISSANCE	EVENT EPREUVE
Poser, Rainer	91	M	164.0	54.0	'41 • 5 • 14	Boxing Boxe
Schlegel, Jurgen	98	M	180.0	81.0	'49 • 10 • 13	"
Schmitt, Wolfgang	93	M	168.0	60.0	'39 • 2 • 26	"
Schulz, Emil	97	M	178.0	75.0	'38 • 5 • 25	"
Schulz, Heinz	92	M	168.0	57.0	'35 • 1 • 5	"
Winter, Heiko	94	M	168.0	63.5	'43 • 2 • 27	"
Bohle, Klaus	51	M	180.0	84.0	'36 • 1 • 14	Canoeing Canotage
Buker, Heinz	52	M	179.0	84.0	'41 • 7 • 6	"
Rossberg, Siegfried		M	183.0	70.0	'36 • 11 • 4	"
Eschert, Jurgen	53	M	176.0	73.0	'41 • 8 • 24	"
Esser, Roswitha	54	F	165.0	65.0	'41 • 1 • 18	"
Felten, Elke	55	F	172.0	65.0	'43 • 7 • 13	"
Heuser, Ingrid	56	F	168.0	67.0	'40 • 1 • 24	"
Lewe, Detlef	57	M	191.0	90.0	'39 • 6 • 20	"
Perleberg, Gunter	58	M	192.0	90.0	'35 • 3 • 17	"
Schulze, Bernhard	59	M	182.0	87.0	'38 • 5 • 30	"
Suhrbier, Erich	60	M	181.0	75.0	'38 • 4 • 25	"
Wentzke, Friedhelm	61	M	179.0	82.0	'35 • 9 • 13	"
Zander, Holger	62	M	176.0	78.0	'43 • 5 • 24	"
Zimmermann, Annemie	63	F	174.0	67.0	'40 • 6 • 10	"
Claesges, Lothar	58	M	180.0	75.0	'42 • 7 • 3	Cycling Cyclisme
Ebert, Burkhard	40	M	180.0	72.0	'42 • 7 • 4	"
Fuggerer, Willi	62	M	174.0	72.0	'41 • 9 • 11	"
Glemser, Peter	42	M	188.0	82.0	'40 • 12 • 12	"
Henrichs, Karl-Heinz	59	M	184.0	83.0	'42 • 7 • 1	"
Hoffmann, Gunter	41	M	175.0	64.0	'39 • 2 • 8	"
Kobusch, Klaus	63	M	180.0	75.0	'41 • 3 • 15	"
Link, Karl	60	M	179.0	72.0	'42 • 7 • 27	"
Peffgen, Wilfried	35	M	173.0	67.0	'42 • 10 • 1	"
Rittmeyer, Immo	43	M	175.0	73.0	'36 • 1 • 6	"
Schillinger, Ulrich	64	M	182.0	76.0	'45 • 2 • 16	"
Schockhoven, Erich	44	M	182.0	76.0	'44 • 11 • 5	"
Spiegelberg, Lothar	65	M	171.0	70.0	'39 • 10 • 24	"
Streng, Ernst	61	M	175.0	67.0	'42 • 1 • 24	"
Allissat, Peter Werner	104	M	.	.	'38 • 5 • 8	Fencing Escrime
Boruceri, Percy	105	M	180.0	72.0	'29 • 7 • 22	"
Brecht, Julius Emil	91	M	176.0	72.0	'40 • 3 • 1	"
Gerresheim, Tim	92	M	180.0	74.0	'39 • 2 • 24	"
Geuter, Wilhelm Friedrich	100	M	182.0	76.0	'37 • 9 • 16	"
Gnaier, Paul Karl Rudolf	97	M	184.0	85.0	'26 • 3 • 8	"
Hecke, Dietrich Eberhard	102	M	184.0	85.0	'35 • 2 • 13	"
Kostner, Walter Georg	103	M	185.0	73.0	'36 • 6 • 28	"
Mees, Helga Margot	86	F	160.0	59.0	'37 • 7 • 12	"
Mehl, Franz Adolf	93	M	181.0	80.0	'35 • 4 • 20	"
Munch, Annerose Else	89	F	168.0	60.0	'38 • 2 • 8	"
Rompza, Franz	98	M	178.0	78.0	'34 • 2 • 12	"
Scherberger, Rosemarie	87	F	165.0	54.0	'35 • 7 • 19	"
Schmid, Katharina Barbara	88	F	166.0	64.0	'38 • 12 • 5	"
Schmitt, Dieter Karl	95	M	184.0	76.5	'40 • 5 • 3	"
Stein, Haakon Heinrich	99	M	183.0	81.0	'40 • 1 • 16	"
Theuerkauff, Gudrun	90	F	159.0	53.5	'37 • 4 • 8	"
Theuerkauff, J	94	M	180.0	72.0	'34 • 9 • 8	"
Wellmann, Dieter	96	M	182.0	71.5	'42 • 12 • 7	"
Wurtz, Volkmar	101	M	190.0	81.0	'38 • 10 • 3	"
Backhaus, Gerd	12	M	180.0	80.0	'42 • 9 • 8	Football
Barthels, Wolfgang	10	M	.	.	'40 • 11 • 23	"
Bauchspiess, Bernd	13	M	182.0	82.0	'39 • 10 • 10	"
Engelhardt, Dieter	11	M	175.0	70.0	'38 • 8 • 18	"
Frassdorf, Otto	15	M	172.0	70.0	'42 • 2 • 5	"

NAME NOM	NO. NO.	SEX SEXE	HEIGHT HAUTEUR	WEIGHT POIDS	DATE OF BIRTH DATE DE NAISSANCE	EVENT EPREUVE
Frenzel, Henning	14	M	176.0	73.0	'42 • 5 • 3	Football
Geisler, Manfred	4	M	175.0	81.0	'41 • 3 • 3	"
Heinsch, Hans Jurgen	1	M	183.0	83.1	'40 • 7 • 4	"
Korner, Gerhard	9	M	176.0	70.5	'41 • 9 • 20	"
Lisiewicz, Klaus	17	M	169.0	65.0	'43 • 2 • 2	"
Noldner, Jurgen	16	M	175.0	75.8	'41 • 2 • 22	"
Pankau, Herbert	7	M	176.0	70.2	'41 • 10 • 4	"
Rock, Peter	8	M	172.0	72.0	'41 • 12 • 16	"
Seehaus, Klaus-Dieter	5	M	178.0	71.0	'42 • 10 • 6	"
Stocker, Hermann	19	M	172.0	65.5	'38 • 1 • 6	"
Unger, Werner	6	M	172.0	71.4	'31 • 5 • 4	"
Urbanczyk, Klaus	2	M	174.0	74.2	'40 • 6 • 4	"
Vogel, Eberhard	18	M	178.0	76.8	'43 • 4 • 8	"
Walter, Manfred	3	M	178.0	82.0	'37 • 7 • 31	"
Weingang, Horst	20	M	185.0	84.0	'40 • 9 • 30	"
Feigner, Christel	64	F	156.0	50.0	'42 • 7 • 25	Gymnastics
Fost, Ingrid	62	F	157.0	53.0	'34 • 11 • 9	Gymastique
Fulle, Siegfried	171	M	168.0	65.0	'39 • 10 • 6	"
Furst, Philipp	172	M	172.0	70.0	'36 • 11 • 8	"
Heritz, Rosemarie	67	F	158.0	49.0	'41 • 1 • 8	"
Jaschek, Willi	177	M	170.0	64.0	'40 • 9 • 2	"
Koppe, Erwin	174	M	165.0	62.5	'38 • 3 • 29	"
Koste, Klaus	175	M	162.0	59.0	'43 • 2 • 27	"
Lyhs, Gunter	173	M	160.0	63.0	'34 • 4 • 20	"
Mannewitz, Karin	65	F	161.0	56.0	'39 • 11 • 15	"
Radochla, Birgit	61	F	163.0	60.0	'45 • 1 • 31	"
Starke, Ute	63	F	166.0	55.5	'39 • 1 • 14	"
Stolz, Barbara	66	F	153.0	51.0	'41 • 6 • 28	"
Weber, Peter	176	M	161.0	60.0	'38 • 2 • 22	"
Arnold, Karl	116	M	172.0	81.0	'40 • 10 • 28	Weight-Lifting
Dittrich, Werner	92	M	166.0	75.0	'37 • 6 • 9	Haltérophilie
Eberle, Martin	33	M	159.0	62.0	'30 • 12 • 20	L. Heavy
Fehr, Norbert	136	M	174.0	90.0	'37 • 5 • 25	Middle
Kornprobst, Alfred	66	M	168.0	70.0	'40 • 7 • 28	Feather
Reck, Hans	3	M	160.0	58.0	'34 • 5 • 31	M. Heavy
Rieger, Manfred	149	M	184.0	105.0	'41 • 4 • 25	Light
Bahner, Klaus	5	M	167.0	63.0	'37 • 11 • 30	Bantam
Brennecke, Horst	4	M	166.0	62.3	'39 • 2 • 10	Heavy
Dahmlos, Horst	6	M	168.0	61.0	'40 • 12 • 16	"
Ehrlich, Dieter	10	M	182.0	83.0	'41 • 9 • 20	"
Freiberger, Karl-Heinz	9	M	174.0	71.5	'41 • 3 • 7	"
Hanschke, Reiner	13	M	176.0	71.2	'40 • 12 • 9	"
Krause, Adolf	11	M	162.0	63.7	'36 • 11 • 25	"
Lippert, Lothar	7	M	170.0	70.0	'39 • 7 • 27	"
Mausert, Frank	15	M	167.0	67.0	'38 • 8 • 23	"
Opitz, Jochen	17	M	180.0	77.5	'41 • 5 • 31	"
Richter, Dieter	16	M	174.0	70.0	'38 • 2 • 25	"
Sasse, Hans-Dietrich	12	M	171.0	64.5	'40 • 7 • 21	"
Stephan, Rainer	1	M	178.0	74.0	'43 • 2 • 17	"
Thieme, Axel	2	M	189.0	86.3	'39 • 5 • 15	"
Traumer, Klaus	14	M	172.0	65.0	'40 • 1 • 27	"
Vetter, Klaus	3	M	172.0	74.1	'34 • 10 • 26	"
Westphal, Rolf	8	M	172.0	70.0	'31 • 1 • 12	"
Wowra, Klaus	18	M	184.0	85.0	'38 • 4 • 2	"
Glahn, Klaus		M	185.0	100.0	'42 • 3 • 23	Judo
Hofmann, Wolfgang		M	177.0	80.0	'41 • 3 • 20	All Weights
Niemann, Herbert		M	187.0	105.0	'35 • 12 • 12	Middle
Schiessleder, Matthias		M	172.0	68.0	'36 • 9 • 23	Heavy
Bauch, Gunter		M	179.0	87.0	'39 • 4 • 30	Wrestling
					Lutte	Free S.-Middle

NAME NOM	NO. NO.	SEX SEXE	HEIGHT HAUTEUR	WEIGHT POIDS	DATE OF BIRTH DATE DE NAISSANCE	EVENT EPREUVE
Dietrich, Wilfried		M	182.0	115.0	'33 • 10 • 14	Wrestling Lutte
Dodrimont, Karl		M	165.0	60.0	'39 • 1 • 14	"
Heinze, Martin		M	170.0	78.0	'31 • 1 • 5	"
Kiehl, Heinz		M	185.0	100.0	'43 • 6 • 6	"
Lacour, Rolf		M	150.0	52.0	'37 • 6 • 26	"
Metz, Lothar		M	178.0	87.0	'39 • 1 • 16	"
Neff, Paul		M	156.0	56.0	'38 • 1 • 10	"
Rost, Klaus		M	172.0	70.0	'40 • 3 • 2	"
Schilling, Rainer		M	168.0	65.0	'43 • 5 • 10	"
Schmitt, Franz		M	170.0	72.0	'37 • 9 • 5	"
Schneider, Lothar		M	163.0	63.0	'37 • 5 • 20	"
Stange, Fritz		M	160.0	65.0	'36 • 9 • 20	"
Vesper, Rudolf		M	175.0	78.0	'39 • 4 • 3	"
Balke, Rainer		M	180.0	79.0	'44 • 8 • 4	Swimming and Diving Natation et Proneons
Beierlein, Traudi		F	171.0	58.0	'41 • 9 • 27	"
Blank, Harriet		F	167.0	61.0	'44 • 10 • 26	"
Brunner, Ursel		F	165.0	56.0	'41 • 1 • 30	"
Dietze, Jurgen		M	177.0	80.0	'42 • 9 • 16	"
Engel-Kramer, Ingrid		F	157.0	54.0	'43 • 7 • 29	"
Freitag, Werner		M	184.0	79.0	'46 • 1 • 4	"
Frischke, Volker		M	176.0	67.0	'44 • 5 • 10	"
Gregor, Horst Gunther		M	190.0	77.0	'38 • 7 • 24	"
Grimmer, Barbel		F	168.0	61.0	'45 • 4 • 7	"
Grunert, Martina		F	160.0	52.0	'49 • 5 • 17	"
Henninger, Egon		M	175.0	77.0	'40 • 6 • 22	"
Hettling, Margit		F	165.0	60.0	'46 • 7 • 3	"
Hetz, Gerhard		M	177.0	76.0	'42 • 7 • 13	"
Hilbert, Angelika		F	153.0	50.0	'42 • 12 • 3	"
Holletz, Veronika		F	164.0	62.0	'45 • 6 • 19	"
Hustede, Heike		F	172.0	63.0	'46 • 1 • 16	"
Jacobsen, Uwe		M	176.0	72.0	'40 • 9 • 22	"
Junga, Heinz		M	182.0	75.0	'43 • 6 • 22	"
Katzur, Klaus		M	190.0	84.0	'43 • 8 • 26	"
Kirschke, Holger		M	177.0	82.0	'47 • 11 • 15	"
Klein, Hans Joachim		M	183.0	82.0	'42 • 8 • 20	"
Klink, Martin		M	174.0	73.0	'40 • 9 • 25	"
Konzorr, Klaus		M	172.0	74.0	'40 • 9 • 22	"
Kremer, Wolfgang		M	178.0	82.0	'45 • 10 • 29	"
Kuper, Ursula		F	180.0	73.0	'37 • 11 • 28	"
Kuppers, Ernst Joachim		M	196.0	98.0	'42 • 8 • 24	"
Lanzke, Christiane		F	156.0	50.0	'47 • 3 • 15	"
Loffler, Horst		M	180.0	78.0	'42 • 3 • 17	"
Lotter, Hermann		M	179.0	81.0	'40 • 3 • 7	"
Messner, Wilhelm		M	175.0	74.0	'40 • 3 • 14	"
Nerger, Petra		F	173.0	62.0	'45 • 7 • 13	"
Neuber, Helga		F	169.0	57.0	'37 • 2 • 19	"
Nimmrich, Gabriele		F	166.0	62.0	'46 • 9 • 22	"
Noack, Ute		F	172.0	68.0	'43 • 1 • 27	"
Ollbrisch, Jutta		F	174.0	70.0	'39 • 6 • 18	"
Pechstein, Heidi		F	171.0	64.0	'44 • 7 • 4	"
Pfeifer, Dieter		M	184.0	80.0	'36 • 11 • 28	"
Platzeck, Wolfgang		M	182.0	77.0	'48 • 3 • 31	"
Pophal, Hans-Dieter		M	177.0	69.0	'37 • 11 • 22	"
Reinhardt, Delia		F	166.0	55.0	'47 • 8 • 27	"
Rosenfeldt, Horst		M	173.0	72.0	'39 • 12 • 8	"
Schmidt, Ingrid		F	177.0	71.0	'45 • 3 • 3	"
Schumacher, Rita		F	177.0	69.0	'37 • 8 • 25	"
Sommer, Peter		M	185.0	80.0	'42 • 12 • 28	"
Sperling, Rolf		M	167.0	62.0	'40 • 4 • 25	"

NAME NOM	NO. NO.	SEX SEXE	HEIGHT HAUTEUR	WEIGHT POIDS	DATE OF BIRTH DATE DE NAISSANCE	EVENT EPREUVE	
Urselmann, Wiltrud		F	181.0	68.0	'42 • 5 • 12	Swimming and Diving Natation et Plongeon	200m Breast
Volker, Gerd		M	167.0	67.0	'42 • 6 • 26	"	High Diving
Wagner, Wolfgang		M	190.0	87.0	'38 • 8 • 6	"	200m Back
Wanke, Jutta		F	162.0	57.0	'48 • 1 • 16	"	400m Free
Weinrich, Steffan		M	179.0	77.0	'45 • 9 • 18	"	400m Ind. Medley
Wiegang, Frank		M	183.0	75.0	'43 • 3 • 15	"	400m, 4X100m Free
Zimmermann, Helga		F	167.0	55.0	'42 • 11 • 2	"	400m Ind. Medley
Adler, Uwe	1	M	182.0	77.0	'44 • 5 • 30	Modern Pentathlon	
Frings, Elmar	2	M	178.0	75.0	'39 • 3 • 26	Pentathlon Moderne	
Goedicke, Wolfgang	3	M	174.0	68.0	'34 • 10 • 22	"	
Werner, Erhard	4	M	176.0	72.0	'35 • 7 • 12	"	
Boldt, Harry		M	184.0	72.0	'30 • 2 • 23	Equestrian Sports	Dressage Grand Prix
Fuhrmann, Karl-Heinz		M	168.0	63.0	'37 • 5 • 18	Sport Equestre	Three-Day Event
Jarasinski, Kurt		M	178.0	70.0	'38 • 11 • 6	"	Jumping Grand Prix
Karsten, Horst		M	170.0	65.0	'36 • 1 • 1	"	Three-Day Event
Klimke, Reiner		M	186.0	70.0	'36 • 1 • 14	"	Dressage Grand Prix
Ligges, Fritz		M	173.0	65.0	'38 • 7 • 29	"	Three-Day Event
Neckermann, Josef		M	182.0	63.0	'12 • 6 • 5	"	Dressage Grand Prix
Schockemohle, Alwin		M	172.0	72.0	'37 • 5 • 29	"	Jumping Grand Prix
Schridde, Hermann		M	176.0	61.0	'37 • 7 • 3	"	Jumping Grand Prix
Schulz, Gerhard		M	172.0	69.0	'31 • 6 • 1	"	Three-Day Event
Winkler, Hans-Gunter		M	173.0	72.0	'26 • 7 • 24	"	Jumping Grand Prix
Bortz, Rudolf	150	M	175.0	76.0	'38 • 6 • 22	Shooting	Small Bore-Prone
Feller, Gerhard	153	M	173.0	70.0	'25 • 1 • 9	Tir	Rapid Fire Pistol
Garreis, Johann	151	M	176.0	78.0	'25 • 2 • 18	"	Free Pistol
Jacobi, Lothar	154	M	182.0	59.0	'39 • 8 • 27	"	Rapid Fire Pistol
Kaupmannsennecke, Hans	152	M	184.0	80.0	'37 • 4 • 23	"	Free Pistol
Kocher, Harry	148	M	167.0	69.0	'33 • 2 • 16	"	Free Rifle, Small Bore-3 P.
Marscheider, Joachim	23	M	179.0	84.0	'30 • 3 • 2	"	Clay Pigeon
Rehder, Heinz	24	M	189.0	81.0	'16 • 3 • 19	"	Clay Pigeon
Wenk, Karl	149	M	184.0	93.0	'34 • 12 • 20	"	Small Bore-Prone
Zachringer, Klaus	147	M	176.0	84.0	'39 • 10 • 17	"	Free Rifle, Small Bore-3 P.
Ballerstedt, Siegfried	4	M	180.0	84.0	'37 • 12 • 5	Water-Polo	
Hohne, Hubert	5	M	189.0	85.0	'38 • 11 • 29	"	
Kluge, Jurgen	9	M	176.0	68.0	'39 • 12 • 29	"	
Mader, Heinz		M	186.0	94.0	'37 • 4 • 13	"	
Schlenkrich, Klaus	3	M	187.0	91.0	'39 • 4 • 26	"	
Schmidt, Peter	1	M	183.0	84.0	'37 • 12 • 10	"	
Schulze, Klaus	8	M	194.0	92.5	'36 • 10 • 17	"	
Thiel, Jurgen	2	M	177.0	86.0	'37 • 3 • 27	"	
Thiele, Edgar	10	M	182.0	82.0	'38 • 2 • 5	"	
Vohs, Dieter	7	M	184.0	83.5	'35 • 6 • 18	"	
Wittig, Heinz	6	M	177.0	81.0	'38 • 3 • 3	"	
Ahrendt, Peter		M	169.0	66.0	'34 • 2 • 2	Yachting	Dragon
Dehmel, Bernd		M	172.0	82.0	'41 • 9 • 15	"	Finn
Gedde, Dietmar		M	178.0	75.0	'36 • 2 • 11	"	F. Dutchman
Herrmann, Horst		M	172.0	74.0	'36 • 2 • 12	"	Reserve
Huttner, Herbert		M	178.0	70.0	'42 • 7 • 21	"	Reserve
Kopperschmidt, Fritz		M	190.0	80.0	'39 • 12 • 22	"	5.5m
Kuhweide, Wilhelm		M	184.0	85.0	'43 • 1 • 6	"	Finn
Lorenz, Wilfred		M	169.0	68.0	'32 • 1 • 18	"	Dragon
Mares, Uwe Horst Conrad		M	173.0	72.0	'42 • 5 • 8	"	Reserve
Mense, Ulrich		M	183.0	100.0	'27 • 1 • 29	"	Dragon
Meyer, Max Adolf Karsten		M	183.5	85.0	'37 • 11 • 5	"	Star
Reich, Herbert		M	176.0	75.0	'38 • 7 • 18	"	5.5m
Reschwamm, Eberhard		M	183.0	65.0	'40 • 3 • 26	"	F. Dutchman
Splieth, Bruno		M	174.0	80.0	'17 • 1 • 20	"	Star
Wagner, Eckart		M	172.0	78.0	'38 • 8 • 4	"	5.5m
GHANA GHANA							
Addy, Ebenezer Charle O.	272	M	178.0	69.5	'40 • 11 • 5	Athletics Athlétisme	4X100m

NAME NOM	NO. NO.	SEX SEXE	HEIGHT HAUTEUR	WEIGHT POIDS	DATE OF BIRTH DATE DE NAISSANCE	EVENT EPREUVE	
Addy, James Aryee	269	M	183.0	76.3	'39 • 12 • 9	Athletics Athlétisme	400m Hurdles, 4X100m, 4X400m
Adjei, Joseph Kobina	275	M	178.0	71.0	'35 • 11 • 3	"	Long Jump
Ahey, Michael Kofi	265	M	188.0	73.5	'39 • 11 • 22	"	100m, 4X100m, Long Jump
Allotey, Stanley Fabian	266	M	171.0	67.6	'42 • 11 • 14	"	100m, 4X100m
Amevor, Eric Donu	271	M	175.0	68.1	'38 • 4 • 16	"	1500m
Anum, Alice	101	F	157.0	44.5	'48 • 10 • 2	"	Long Jump
Boateng, Christiana A.	100	F	163.0	53.6	'43 • 2 • 24	"	100m
Bugri, Samuel Zanya	273	M	183.0	66.7	'43 • 4 • 2	"	4X400m
Hart, Rose	99	F	170.0	61.3	'42 • 1 • 9	"	100m, 80m Hurdles
Mensah-Brobbe	274	M	170.0	61.3	'34 • 12 • 25	"	4X400m
Okantey, Michael F.	267	M	178.0	70.4	'38 •	"	200m, 4X100m, 4X400m
Owusu-Mensah, Samuel	270	M	171.0	65.8	'44 • 9 • 22	"	400m, 4X100m, 4X400m
Quartey, Ebenezer Quayee	268	M	173.0	64.9	'35 • 8 • 25	"	400m, 4X400m
Amekudji, Sammy Lee	102	M	.	.	'39 • 12 • 25	Boxing Boxe	Light
Arimi, Thomas	106	M	.	.	'33 • 10 • 17	"	L. Heavy
Aryee, Cassis	101	M	.	.	'41 • 4 • 1	"	Bantam
Blay, Eddie	103	M	.	.	'40 • 12 • 9	"	L. Welter
Darkey, Joe	105	M	.	.	'42 • 5 • 22	"	Middle
Davies, Eddie	104	M	.	.	'37 • 12 • 1	"	L. Middle
Shittu, Sulley	100	M	.	.	'46 • 4 • 15	"	Fly
Acheampong Ben	4	M	160.6	62.0	'39 • 2 • 2	Football	
Acquah, Edward	10	M	188.0	82.0	'35 • 7 • 23	"	
Acquah, Sam	2	M	178.0	72.0	'43 • 7 • 10	"	
Addo-Odametey	5	M	171.5	66.0	'37 • 2 • 23	"	
Adjei, Joseph Kobina	21	M	178.0	71.0	'35 • 11 • 3	"	
Adoquaye, Laryea	13	M	178.0	76.0	'36 • 1 • 10	"	
Aggrey Fynn, Edward Jona	9	M	180.0	74.0	'34 • 11 • 24	"	
Agyemang, Gyau	17	M	168.0	68.5	'39 • 6 • 3	"	
Anoi, Cofie	19	M	163.0	64.5	'42 • 9 • 21	"	
Atta, Kwame	14	M	170.0	63.5	'35 • 11 • 22	"	
Dodoo-Ankrah	1	M	177.0	73.0	'34 • 3 • 8	"	
Gibirine, Abdul Ramonu	12	M	179.0	64.5	'40 • 8 • 14	"	
Mfum, Wilberforce	8	M	173.0	76.0	'36 • 8 • 28	"	
Nkansah, Emmanuel Kwesi	6	M	185.0	74.5	'41 • 10 • 15	"	
Oblitey, Emmanuel	3	M	165.0	64.0	'34 • 2 • 5	"	
Odoi, Frank	20	M	160.0	64.0	'43 • 2 • 23	"	
Ofori, Gladstone	15	M	170.0	59.5	'43 • 10 • 8	"	
Okai, Samuel Anum	16	M	165.0	63.0	'36 • 6 • 6	"	
Oser, Kofi	7	M	160.0	58.0	'42 • 6 • 3	"	
Pare, Kofi	11	M	176.0	72.5	'38 • 11 • 28	"	
Salisu, Mohammedu	18	M	170.0	60.5	'34 • 9 • 10	"	
GREECE GREECE							
Manglaras, Dimos	278	M	178.0	72.0	'40 •	Athletics Athlétisme	Long Jump
Marsellos, Georges	276	M	188.0	75.0	'36 •	"	110m Hurdles
Mousiadis, Christostomos	279	M	181.0	73.0	'41 •	"	Triple Jump
Papanikolaou, Christos	277	M	180.0	73.0	'42 • 11 • 25	"	Pole Vault
Pierrakos, Christos	281	M	188.0	85.0	'40 •	"	Javelin Throw
Tsakanikas, Georges	280	M	189.0	105.0	'34 •	"	Shot Put, Discus Throw
Galaktopoulos, Petros		M	166.0	63.0	'45 • 3 • 4	Wrestling Lutte	Greco R.-Feather
Ganotis, Vasilios		M	160.0	52.0	'42 • 2 • 1	"	Greco R.-Fly
Ioannidis, Stefanos		M	173.0	63.0	'33 • 3 • 23	"	Free S.-Light
Savvas, Dimitrios		M	171.0	70.0	'39 • 9 • 17	"	Greco R.-Light
Zafiropoulos, Athanasios		M	162.0	52.0	'44 • 2 • 12	"	Free S.-Fly
Issaakidis, Fotis	37	M	172.0	80.0	'08 • 5 • 29	Shooting Tir	Clay Pigeon
Manthos, Evlambios	161	M	167.0	69.0	'34 • 1 • 30	"	Small Bore-3 P., Prone
Pangalos, Georges	38	M	173.0	73.0	'36 • 6 • 21	"	Clay Pigeon
Papageorgopoulos. A.	162	M	178.0	73.0	'37 • 3 • 24	"	Rapid Fire Pistol
Eskitzoglou, Odiseefs		M	160.0	65.0	'32 • 5 • 3	Yachting	Dragon

NAME NOM	NO. NO.	SEX SEXE	HEIGHT HAUTEUR	WEIGHT POIDS	DATE OF BIRTH DATE DE NAISSANCE	EVENT EPREUVE	
Koulingas, Panaghiotis		M	180.0	76.0	'46 • 3 • 31	Yachting	Finn
Magoulas, Themistoklis		M	170.0	69.0	'27 • 12 • 21	"	Dragon
Voridis, Christos		M	176.0	80.0	'33 • 5 • 2	"	Reserve
Zaimis, Georges		M	176.0	70.0	'37 • 6 • 28	"	Dragon
HONG KONG HONG-KONG							
Chu, Ming	284	M	169.0	64.0	'32 • 9 • 24	Athletics Athlétisme	Long Jump, Triple Jump
Field, Patrick M. M.	283	M	174.0	63.6	'37 • 6 • 6	"	800m, 1500m
Hill, William	282	M	189.0	63.6	'45 • 6 • 11	"	200m, 400m
So, Kam Tong	285	M	169.0	59.1	'37 • 6 • 8	"	50km Road Walk
Law, Hon Pak	108	M	177.0	54.0	'39 • 7 • 14	Boxing Boxe	Bantam
Lee, Kam Wah	107	M	180.0	51.0	'40 • 5 • 14	"	Fly
Chow, Kwong Choi	76	M	170.0	59.0	'43 • 12 • 3	Cycling Cyclisme	Ind. Pursuit, Road
Chow, Kwong Man	51	M	167.0	58.0	'43 • 12 • 3	"	Ind. Road
Mok, Sau Hei	52	M	172.0	63.0	'41 • 1 • 24	"	Ind. Road
Watson, Michael John	75	M	180.0	68.0	'38 • 1 • 14	"	1000m T. T., Ind. Road
Castro, Daniel Francisco	9	M	175.0	72.0	'37 • 7 • 3	Hockey	
Collaco, Joaquim Jose Jr.	14	M	164.0	60.8	'34 • 3 • 17	"	
Cunha, Jose Policarpo Da	17	M	163.0	68.0	'35 • 8 • 12	"	
Da Silva, Rui Ayres	6	M	155.0	58.0	'39 • 1 • 5	"	
Dallah, Omar Kachung	8	M	155.0	74.0	'36 • 8 • 12	"	
Dillon, Sarinder Singh	15	M	156.0	53.0	'46 • 12 • 11	"	
Gardner, Packey Benjamin	10	M	175.0	74.0	'29 • 5 • 29	"	
Grewal, Harnam Singh	2	M	183.0	70.0	'37 • 12 • 5	"	
Guterres, Lionel H.	11	M	177.0	61.0	'31 • 9 • 7	"	
Hussain, Zia	16	M	157.0	73.0	'38 • 7 • 1	"	
Kadir, Slawee	1	M	165.0	60.0	'33 • 6 • 28	"	
Khan, Farid	3	M	177.0	72.0	'36 • 2 • 18	"	
McCosh, Frederic Samuel	4	M	183.0	83.0	'38 • 1 • 6	"	
Monteiro, John Jude	12	M	188.0	68.0	'38 • 11 • 28	"	
Rahman, Kader	13	M	155.0	71.0	'38 • 12 • 29	"	
Silva, Joao Bosco Quevedo	5	M	168.0	61.0	'37 • 3 • 8	"	
Singh, Kuldip	7	M	172.0	59.0	'46 • 6 • 23	"	
Chan, Kam Hong		M	169.0	57.6	'46 • 7 • 29	Swimming and Diving Natation et Plongeurs	200m Back
Li, Hin Yu		F	160.0	48.5	'48 • 1 • 4	"	200m Breast
Loh, Robert		M	174.0	69.4	'46 • 1 • 24	"	100m, 400m, 1500m Free
Gillies, William Mckay	167	M	188.0	77.2	'14 • 9 • 14	Shooting Tir	Free Pistol
Hoo, Kam Chiu	166	M	177.0	68.1	'10 • 5 • 7	"	Free Pistol
Remedios, Reginald R.	163	M	169.0	63.6	'22 • 12 • 22	"	Free Rifle, Small Bore-3 P.
Rull, Peter Augustus	164	M	172.0	74.5	'23 • 11 • 17	"	Free Rifle, Small Bore-3 P., Prone
Souza, Henry Anthony	165	M	168.0	66.5	'21 • 7 • 21	"	Small Bore-Prone
D. A. C. T. Hancock, Bill		M	165.0	95.0	'21 • 5 • 28	Yachting	Reserve
P. J. Coope, Paul		M	152.0	77.0	'28 • 1 • 13	"	Dragon
Park, John		M	158.0	94.0	'24 • 6 • 4	"	Dragon
Stevens, Alan		M	156.0	79.0	'33 • 1 • 20	"	Finn
W. Turnbull, Bill		M	153.0	84.0	'33 • 11 • 12	"	Dragon
HUNGARY HONGRIE							
Bartoss, Heldt Erzsebet	103	F	162.0	52.0	'41 • 1 • 31	Athletics Athlétisme	100m, 200m, 4X100m
Bognar, Judit	109	F	174.0	72.0	'39 • 1 • 28	"	Shot Put, Discus Throw
Csutoras, Csaba	286	M	186.0	84.0	'37 • 9 • 13	"	100m, 200m, 4X100m, 4X400m
Eckschmiedt, Sandor	302	M	184.0	100.0	'38 • 10 • 25	"	Hammer Throw
Gori, Istvan	305	M	168.0	50.0	'38 • 6 • 4	"	20km, 50km Road Walk
Gyulai, Istvan	289	M	180.0	73.0	'43 • 3 • 21	"	400m, 4X100m, 4X400m
Havasi, Istvan	303	M	161.0	55.0	'30 • 12 • 21	"	20km, 50km Road Walk
Kalocsai, Henrik	296	M	191.0	84.0	'40 • 11 • 28	"	4X100m, Long Jump, Triple Jump
Kazi, Olga	106	F	167.0	56.0	'41 • 5 • 10	"	400m, 800m, 4X100m
Kispal, Skultety Etelka	108	F	174.0	63.0	'41 • 10 • 25	"	4X100m, Long Jump
Kiss, Antal	304	M	176.0	62.0	'35 • 12 • 30	"	20km, 50km Road Walk
Kleiber, Kontser Jolan	110	F	178.0	81.0	'39 • 8 • 29	"	Shot Put, Discus Throw
Kulcsar, Gergely	300	M	184.0	82.0	'34 • 3 • 10	"	Javelin Throw

NAME NOM	NO. NO.	SEX SEXE	HEIGHT HAUTEUR	WEIGHT POIDS	DATE OF BIRTH DATE DE NAISSANCE	EVENT EPREUVE	
Macsar, Jozsef	294	M	172.0	60.0	'38 • 9 • 13	Athletics Athlétisme	3000m S. C.
Mecser, Lajos	291	M	176.0	69.0	'42 • 9 • 23	"	5000m, Marathon
Mihalyfi, Laszlo	287	M	182.0	78.0	'39 • 9 • 21	"	100m, 4X100m, 4X400m
Munkacsi, Antonia	105	F	166.0	58.0	'38 • 11 • 26	"	400m, 4X100m
Nagy, Zsigmond	298	M	180.0	100.0	'37 • 7 • 27	"	Shot Put
Nemeshazi, Marko Margit	102	F	164.0	53.0	'43 • 10 • 13	"	100m, 200m, 4X100m
Pinter, Janos	292	M	173.0	54.0	'36 • 11 • 28	"	5000m, 10000m, Marathon
Rabai, Gyula	295	M	172.0	65.0	'42 • 2 • 6	"	4X100m, 4X400m
Rozsnyai, Huba	288	M	173.0	68.0	'42 • 12 • 14	"	100m, 4X100m, 4X400m
Rudas, Antal Marta	112	F	164.0	64.0	'37 • 2 • 14	"	Javelin Throw
Simon, Attila	290	M	179.0	62.0	'39 • 3 • 22	"	1500m, 5000m, 3000m S. C.
Stugner, Judit	111	F	176.0	80.0	'42 • 1 • 22	"	Discus Throw
Such, Ida	104	F	161.0	53.0	'40 • 7 • 6	"	4X100m
Suetoe, Jozsef	293	M	174.0	58.0	'37 • 9 • 9	"	10000m, Marathon
Szabo, Nagy Zsuzsa	107	F	167.0	52.0	'40 • 1 • 16	"	800m
Szecsényi, Jozsef	299	M	184.0	98.0	'32 • 1 • 10	"	Discus Throw
Varju, Vilmos	297	M	190.0	112.0	'37 • 6 • 10	"	Shot Put
Zsivotzky, Gyula	301	M	190.0	93.0	'37 • 2 • 25	"	Hammer Throw
Bencze, Janos	12	M	198.0	108.0	'34 • 10 • 12	Basket-Ball	
Bohaty, Miklos	4	M	192.0	87.0	'35 • 12 • 6	"	
Gabanyi, Laszlo	5	M	202.0	97.0	'35 • 5 • 15	"	
Glatz, Arpad	15	M	191.0	88.0	'39 • 1 • 5	"	
Greminger Janos	8	M	179.0	67.0	'29 • 5 • 5	"	
Haan, Andras	14	M	185.0	80.0	'46 • 6 • 19	"	
Kangyal, Tibor	10	M	185.0	78.0	'42 • 5 • 28	"	
Koczka, Pal	7	M	194.0	84.0	'39 • 3 • 22	"	
Lendvai, Odon	11	M	196.0	94.0	'43 • 1 • 24	"	
Polik, Gyorgy	6	M	191.0	85.0	'39 • 9 • 9	"	
Prieszol, Jozsef	9	M	193.0	88.0	'42 • 11 • 19	"	
Racz, Janos	13	M	185.0	85.0	'41 • 8 • 3	"	
Kajdi, Janos	111	M	168.0	60.0	'39 • 12 • 30	Boxing Boxe	Light
Papp, Tibor	109	M	160.0	51.0	'44 • 4 • 5	"	Fly
Sebok, Laszlo	113	M	173.0	71.0	'37 • 11 • 13	"	L. Middle
Torok, Gyula	110	M	160.0	54.0	'38 • 1 • 24	"	Bantam
Toth, Istvan	112	M	166.0	63.5	'38 • 4 • 25	"	L. Welter
Benko, Katalin	64	F	176.0	70.0	'41 • 5 • 12	Canoeing Canotage	Kayak 1, 2
Fabian, Laszlo	65	M	185.0	79.0	'36 • 7 • 10	"	Reserve
Gyuru, Endre	66	M	176.0	75.0	'45 • 5 • 27	"	Reserve
Hajba, Antal	67	M	180.0	78.0	'38 • 1 • 16	"	Canadian 2
Hesz, Mihaly	68	M	186.0	75.0	'34 • 12 • 15	"	Kayak 1
Jantolecz, Ilona	69	F	166.0	55.0	'44 • 10 • 6	"	Reserve
Kemecsey, Imre	70	M	170.0	73.0	'41 • 2 • 11	"	Kayak 4
Kovacs, Kalman	71	M	178.0	79.0	'42 • 6 • 13	"	Reserve
Meszaros, Gyorgy	72	M	182.0	80.0	'33 • 4 • 30	"	Kayak 2, 4
Parti, Janos	74	M	183.0	84.0	'32 • 10 • 24	"	Reserve
Roka, Maria	75	F	172.0	65.0	'40 • 9 • 15	"	Kayak 2
Soltész, Arpad	76	M	181.0	78.0	'44 • 11 • 16	"	Canadian 2
Szente, Andras	77	M	181.0	81.0	'39 • 12 • 10	"	Kayak 4
Szollosi, Imre	78	M	182.0	82.0	'41 • 2 • 19	"	Kayak 2, 4
Toro, Andras	79	M	176.0	69.0	'40 • 7 • 10	"	Canadian 1
Bicskey, Richard	78	M	164.0	74.0	'36 • 10 • 4	Cycling Cyclisme	Scratch, Tandem Sprint
Habony, Ferenc	77	M	178.0	75.0	'45 • 2 • 26	"	1000m T. T., Scratch, Tandem Sprint
Juszko, Janos	54	M	181.0	78.0	'39 • 6 • 9	"	Road Ind., Team T. T.
Maho, Laszlo	56	M	175.0	70.0	'41 • 3 • 10	"	Road Ind., Team T. T.
Megyerdi, Antal	55	M	169.0	65.0	'39 • 12 • 5	"	Road Ind., Team T. T.
Meszaros, Andras	58	M	177.0	68.0	'41 • 4 • 2	"	Reserve
Stamusz, Ferenc	57	M	178.0	72.0	'34 • 8 • 21	"	Road Ind., Team T. T.
Bakonyi, Peter	122	M	181.0	72.0	'38 • 2 • 17	Fencing Escrime	Sabre Ind., Team
Barany, Arpad	120	M	172.0	60.0	'31 • 6 • 24	"	Epee Team

NAME NOM	NO. NO.	SEX SEXE	HEIGHT HAUTEUR	WEIGHT POIDS	DATE OF BIRTH DATE DE NAISSANCE	EVENT EPREUVE	
Foldesi Marosi, Paula	110	F	170.0	62.0	'36 • 11 • 3	Fencing	Foil Team
Gabor, Tamas	117	M	183.0	76.0	'32 • 4 • 24	Escrime	Epee Team
Gyarmati, Bela	115	M	176.0	68.0	'42 • 3 • 5	"	Foil Team
Gyuricza, Jozsef	114	M	175.0	66.0	'34 • 1 • 16	"	Foil Ind., Team
Horvath, Zoltan	125	M	184.0	73.0	'37 • 3 • 12	"	Sabre Team
Juhasz, Katalin	108	F	164.0	62.0	'32 • 11 • 24	"	Foil Ind., Team
Kamuti, Jenő	112	M	172.0	68.0	'37 • 9 • 17	"	Foil Ind., Team
Kamuti, Laszlo	111	M	178.0	72.0	'40 • 1 • 31	"	Foil Team
Kausz, Istvan	116	M	181.0	72.0	'32 • 9 • 18	"	Epee Ind., Team
Kovacs, Attila	121	M	184.0	75.0	'39 • 12 • 30	"	Sabre Ind., Team
Kulcsar, Gyozo	118	M	188.0	73.0	'40 • 10 • 18	"	Epee Ind., Team
Mendelenyi Agoston, Judit	109	F	164.0	62.0	'37 • 1 • 13	"	Foil Team
Meszena, Miklos	124	M	182.0	80.0	'40 • 12 • 14	"	Sabre Team
Nemere, Zoltan	119	M	185.0	85.0	'42 • 4 • 20	"	Epee Ind., Team
Pezsa, Tibor	123	M	190.0	82.0	'35 • 11 • 15	"	Sabre Ind., Team
Sakovics Domolky, Lidia	107	F	166.0	56.0	'36 • 3 • 9	"	Foil Ind., Team
Szabo, Sandor	113	M	178.0	68.0	'41 • 1 • 26	"	Foil Ind., Team
Ujlaki Rejto, Ildiko	106	F	164.0	58.0	'37 • 5 • 11	"	Foil Ind., Team
Bene, Ferenc	13	M	170.0	70.0	'44 • 12 • 17	Football	
Csernai, Tibor	2	M	175.0	70.0	'38 • 12 • 3	"	
Dunai, Antal	14	M	180.0	76.0	'43 • 3 • 21	"	
Farkas, Janos	15	M	172.0	72.0	'42 • 3 • 27	"	
Gelei, Jozsef	19	M	179.0	76.0	'38 • 6 • 29	"	
Ihasz, Kalman	6	M	170.0	67.0	'41 • 3 • 6	"	
Kaposzta, Beno	4	M	170.0	67.0	'42 • 6 • 7	"	
Katona, Sandor	16	M	166.0	64.0	'43 • 2 • 21	"	
Komora, Imre	11	M	172.0	68.0	'40 • 6 • 5	"	
Nagy, Gyorgy	10	M	166.0	61.0	'42 • 7 • 30	"	
Nagy, Istvan	9	M	172.0	67.0	'39 • 4 • 14	"	
Nogradi, Ferenc	18	M	172.0	66.0	'40 • 11 • 15	"	
Novak, Dezso	3	M	180.0	78.0	'39 • 2 • 3	"	
Orban, Arpad	5	M	190.0	84.0	'38 • 3 • 14	"	
Orosz, Pal	17	M	175.0	70.0	'34 • 1 • 25	"	
Palotai, Karoly	8	M	175.0	75.0	'35 • 9 • 11	"	
Szentmihalyi, Antal	1	M	186.0	75.0	'39 • 6 • 13	"	
Szepesi, Gusztav	7	M	178.0	72.0	'39 • 7 • 17	"	
Varga, Zoltan	12	M	176.0	62.0	'45 • 1 • 1	"	
Aranyos, Istvan	152	M	169.0	63.0	'42 • 4 • 25	Gymnastics	
Csanyi, Rajmund	151	M	171.0	68.0	'36 • 4 • 22	Gymnastique	
Cser, Gyozo	156	M	168.0	67.0	'42 • 10 • 29	"	
Endrodi, Katalin	17	F	163.0	58.0	'45 • 12 • 18	"	
Erdosi, Tolnai Marta	16	F	161.0	55.0	'41 • 8 • 23	"	
Janosi, Ducza Aniko	11	F	161.0	57.0	'42 • 8 • 8	"	
Kovacs, Mak Gyongyi	12	F	153.0	49.0	'40 • 2 • 21	"	
Lelkes, Andras	154	M	172.0	68.0	'35 • 12 • 22	"	
Makray, Katalin	13	F	167.0	57.0	'45 • 4 • 5	"	
Muller, Katalin	15	F	158.0	52.0	'43 • 9 • 13	"	
Sos, Peter	155	M	169.0	69.0	'38 • 1 • 3	"	
Tressel, Maria	14	F	162.0	62.0	'46 • 7 • 29	"	
Varga, Lajos	153	M	167.0	69.0	'33 • 11 • 23	"	
Ecser, Karoly	157	M	173.0	113.0	'31 • 10 • 22	Weight-Lifting	Heavy
Foldi, Imre	17	M	150.0	56.0	'38 • 5 • 8	Haltérophilie	Bantam
Huszka, Mihaly	93	M	170.0	75.0	'33 • 6 • 2	"	Middle
Nagy, Robert	18	M	149.0	56.0	'40 • 6 • 3	"	Bantam
Nemessanyi, Arpad	138	M	172.0	90.0	'44 • 5 • 15	"	M. Heavy
Toth, Geza	118	M	172.0	82.5	'32 • 1 • 25	"	L. Heavy
Veres, Gyozo	119	M	165.0	82.5	'36 • 6 • 23	"	L. Heavy
Alker, Imre		M	157.0	52.0	'41 • 12 • 1	Wrestling	Greco R.-Fly
Bajko, Karoly		M	181.0	78.0	'44 • 8 • 1	Lutte	Free S.-Welter

NAME NOM	NO. NO.	SEX SEXE	HEIGHT HAUTEUR	WEIGHT POIDS	DATE OF BIRTH DATE DE NAISSANCE	EVENT EPREUVE
Hollosi, Geza		M	174.0	87.0	'38 • 5 • 2	Wrestling Lutte
Kiss, Ferenc		M	184.0	97.0	'42 • 1 • 5	"
Kozma, Istvan		M	198.0	135.0	'39 • 11 • 27	"
Polyak, Imre		M	170.0	63.0	'32 • 4 • 16	"
Reznak, Janos		M	176.0	116.0	'30 • 12 • 12	"
Rizmayer, Antal		M	176.0	78.0	'39 • 11 • 5	"
Varga, Janos		M	168.0	57.0	'39 • 10 • 21	"
Vigh, Imre		M	185.0	97.0	'38 • 4 • 3	"
Ali, Csaba		M	175.0	72.0	'46 • 11 • 4	Swimming and Diving Natation et Plongeoons
Balla, Maria		F	168.0	60.0	'44 • 12 • 6	"
Bodnar, Andras		M	178.0	82.0	'42 • 4 • 9	"
Csikany, Jozsef		M	182.0	78.0	'43 • 4 • 26	"
Dobai, Gyula		M	178.0	76.0	'37 • 11 • 18	"
Dobai, Madarasz Csilla		F	167.0	62.0	'43 • 6 • 23	"
Dora, Jozsef		M	171.0	58.0	'41 • 5 • 7	"
Egervari, Marta		F	165.0	65.0	'43 • 3 • 24	"
Erdelyi, Eva		F	172.0	62.0	'43 • 9 • 15	"
Frank, Maria		F	168.0	62.0	'43 • 9 • 8	"
Gulrich, Jozsef		M	180.0	80.0	'42 • 5 • 22	"
Gulyas, Akos		M	189.0	79.0	'42 • 8 • 14	"
Katona, Jozsef		M	179.0	75.0	'41 • 9 • 12	"
Kosztolanczi, Gyorgy		M	181.0	76.0	'46 • 2 • 17	"
Kovacs, Zsuzsa		F	168.0	60.0	'45 • 11 • 13	"
Lenkei, Ferenc		M	178.0	78.0	'46 • 3 • 23	"
Szall, Antal		M	175.0	73.0	'44 • 1 • 26	"
Szlamka, Laszlo		M	178.0	78.0	'43 • 9 • 18	"
Takacs, Katalin		F	172.0	63.0	'42 • 6 • 25	"
Turoczy, Judit		F	162.0	57.0	'48 • 3 • 11	"
Nagy, Imre	22	M	171.0	76.0	'33 • 2 • 21	Modern Pentathlon Pentathlon Moderne
Szaniszlo, Jozsef	23	M	168.0	66.0	'35 • 9 • 4	"
Torok, Ferenc	24	M	176.0	67.0	'35 • 8 • 3	"
Torok, Otto	25	M	178.0	68.0	'37 • 11 • 1	"
Balla, Gabor	174	M	185.0	75.0	'41 • 12 • 23	Shooting Tir
Gonczi, Ferenc	173	M	175.0	81.0	'35 • 9 • 29	"
Hammerl, Laszlo	171	M	180.0	84.0	'42 • 2 • 15	"
Jakosits, Tibor	170	M	175.0	73.0	'38 • 3 • 18	"
Kelemen, Lajos	172	M	174.0	85.0	'29 • 6 • 8	"
Kun, Szilard	175	M	178.0	80.0	'35 • 3 • 23	"
Sandor, Zoltan	168	M	166.0	70.0	'26 • 3 • 28	"
Simko, Imre	169	M	176.0	76.0	'39 • 1 • 6	"
Bodo, Gabor	4	M	182.0	73.0	'41 • 8 • 5	Volley-Ball
Czafik, Bela	1	M	173.0	71.0	'37 • 9 • 23	"
Florian, Tibor	8	M	192.0	77.0	'38 • 2 • 4	"
Galos, Laszlo	9	M	189.0	78.0	'33 • 4 • 3	"
Ivancso, Vilmos	2	M	177.0	72.0	'39 • 2 • 23	"
Janosi, Ferenc	12	M	189.0	84.0	'38 • 6 • 17	"
Kangyerka, Antal	10	M	184.0	70.0	'39 • 9 • 23	"
Lantos, Csaba	3	M	187.0	86.0	'43 • 5 • 2	"
Molnar, Istvan	5	M	192.0	90.0	'37 • 10 • 9	"
Prouza, Otto	6	M	180.0	81.0	'33 • 6 • 13	"
Tatar, Mihaly	11	M	189.0	85.0	'37 • 7 • 4	"
Tuske, Ferenc	7	M	183.0	78.0	'42 • 12 • 21	"
Ambrus, Miklos		M	185.0	90.0	'33 • 5 • 31	Water Polo
Boros, Otto		M	185.0	95.0	'29 • 8 • 5	"
Domotor, Zoltan		M	182.0	85.0	'35 • 8 • 21	"
Felkai, Laszlo		M	182.0	78.0	'41 • 3 • 1	"
Gyarmati, Dezso		M	184.0	80.0	'27 • 10 • 23	"
Kanizsa, Tivadar		M	177.0	76.0	'33 • 4 • 4	"
Karpati, Gyorgy		M	168.0	72.0	'35 • 6 • 23	"

NAME NOM	NO. NO.	SEX SEXE	HEIGHT HAUTEUR	WEIGHT POIDS	DATE OF BIRTH DATE DE NAISSANCE	EVENT EPREUVE
Konrad II., Janos		M	180.0	88.0	'41 • 8 • 27	Water Polo
Mayer, Mihaly		M	183.0	80.0	'33 • 12 • 27	"
Pocsik, Denes		M	185.0	90.0	'40 • 3 • 9	"
Rusoran, Peter		M	176.0	72.0	'40 • 4 • 11	"
Finaczy, Gyorgy		M	173.0	70.0	'42 • 5 • 25	Yachting Finn
ICELAND ISLANDE						
Olafsson, Jon Th.	306	M	194.0	.	'41 • 6 • 21	Athletics Athlétisme High Jump
Thorlaksson, Valbjorn	207	M	184.0	.	'34 • 6 • 9	" Pole Vault, Decathlon
Gislasoh, Gudmundur		M	179.0	.	'41 • 1 • 19	Swimming and Diving Natation et Plongeurs 100m Free, 400m Ind. Medley
Gudmundsdottir, H.		F	187.0	.	'43 • 7 • 9	" 100m Free, Butterfly
INDIA INDE						
Akotkar, Balkrishan	320	M	171.0	57.2	'37 • 7 • 1	Athletics Athlétisme Marathon
Bondada Venkata, S.	314	M	170.0	57.0	'35 • 5 • 9	" 4X100m, Long Jump
Coutinho, Anthony Francis	315	M	172.0	63.0	'40 • 8 • 25	" 4X100m
D Souza, Stephie	113	F	158.0	50.5	'36 • 12 • 26	" 400m
Harbanslal, Harbanslal	319	M	171.0	63.0	'38 • 4 • 11	" Marathon
Pal, Amrit	313	M	178.0	67.0	'39 • 6 • 5	" 400m Hurdles, 4X400m
Pichaya, Rajasekaran	316	M	167.0	57.0	'41 • 1 • 3	" 4X100m
Powell, Kenneth Lawrence	309	M	171.0	61.0	'40 • 4 • 20	" 100m, 200m, 4X100m, 4X400m
Randhawa, Gurbachan Singh	312	M	182.0	72.0	'39 • 6 • 6	" 110m Hurdles, 4X400m
Singh, Ajmer	317	M	185.0	72.6	'40 • 2 • 1	" 4X400m
Singh, Labh	318	M	173.0	56.7	'39 • 4 • 25	" Triple Jump
Singh, Makhan	310	M	167.0	67.5	'38 • 10 • 28	" 400m, 4X100m, 4X400m
Singh, Milkha	311	M	168.0	67.6	'35 • 11 • 20	" 400m, 4X100m, 4X400m
Bhadur Mall, Padam	115	M	.	.		Boxing Boxe Light
Swamy, Denis	114	M	.	.		" Feather
Billing, Amar Singh	80	M	175.0	62.0	'44 • 1 • 10	Cycling Cyclisme Scratch Sprint, Team Pursuit, Road Team T. T.
Gill, Dalbir Singh	81	M	.	.	'36 • 11 • 25	" 1000m T. T., Team Pursuit Road Team T. T.
Heri, Chetan Singh	82	M	.	.	'36 • 9 • 14	" Team Pursuit, Road Team T. T.
Singh, Suchha	83	M	.	.	'33 • 7 • 21	" Scratch Sprint
Sokhi, Amar Singh	84	M	.	.	'35 • 7 • 2	" Ind. Pursuit, Road Team T. T.
Bhosle, B.	163	M	.	.	'45 • 10 • 10	Gymnastics Gymnastique
Karande, Vithal	166	M	.	.	'40 • 3 • 12	"
Mondai, D.	161	M	.	.	'40 • 6 • 7	"
More, Y.	164	M	.	.	'44 • 9 • 10	"
Ram, Anant	165	M	.	.	'32 • 10 • 21	"
Singh, Trilok	162	M	.	.	'33 • 6 • 13	"
Das, A. K.	4	M	160.0	55.5	'35 • 9 • 6	Weight-Lifting Haltérophilie Bantam
Das, L. K.	42	M	162.5	60.0	'39 • 11 • 1	" Feather
Ghosh, M. L.	5	M	162.5	55.0	'44 • 6 • 21	" Bantam
Christy, R. A.	12	M	163.0	59.0	'38 • 7 • 1	Hockey
Harbinder, Singh	9	M	165.0	63.0	'43 • 7 • 8	"
Kaushik, Hari Pal	8	M	178.0	77.0	'34 • 2 • 2	"
Laxman, S.	1	M	163.0	64.0	'33 • 7 • 1	"
Mohinder, Lal	4	M	165.0	63.0	'36 • 6 • 1	"
Patil, Bandu	14	M	160.0	61.0	'36 • 1 • 1	"
Peter, V. J.	15	M	165.0	67.0	'37 • 6 • 19	"
Sayeed, Ali	18	M	165.0	61.0	'42 • 7 • 10	"
Singh, Balbir	17	M	168.0	65.0	'42 • 8 • 8	"
Singh, Charanjit	5	M	171.0	69.0	'31 • 2 • 22	"
Singh, Darshan	11	M	170.0	72.0	'38 • 4 • 15	"
Singh, Dhara M.	3	M	170.0	65.0	'37 • 10 • 30	"
Singh, Gurbux	2	M	170.0	64.0	'35 • 2 • 11	"
Singh, Jagjit	16	M	170.0	58.0	'44 • 1 • 1	"
Singh, Joginder	7	M	170.0	70.0	'40 • 8 • 13	"
Singh, Prithi Pal	13	M	175.0	71.0	'32 • 1 • 28	"
Singh, Rajinder	6	M	165.0	66.0	'38 • 6 • 14	"
Singh, Udhum	10	M	163.0	60.0	'28 • 8 • 4	"

NAME NOM	NO. NO.	SEX SEXE	HEIGHT HAUTEUR	WEIGHT POIDS	DATE OF BIRTH DATE DE NAISSANCE	EVENT EPREUVE	
Andalkar, Ganpat		M	183.0	97.0	'35 • 4 • 15	Wrestling Lutte	Free S., Greco R.-Heavy
Bishambhar		M	.	57.0		"	Free S., Greco R.-Bantam
Chand, Udey		M	174.0	70.0	'37 • 7 • 24	"	Free S., Greco R.-Light
Malwa		M	137.0	52.0	'40 • 3 • 14	"	Free S., Greco R.-Fly
Mane, Manuti		M	175.0	97.0	'38 • 8 • 10	"	Free S., Greco R.-L. Heavy
Patil, Bandu		M	.	63.0	'42 • 9 • 16	"	Free S., Greco R.-Feather
Singh, Jit		M	175.0	87.0	'37 • 1 • 13	"	Free S., Greco R.-Middle
Singh, Madho		M	171.0	78.0	'29 • 7 • 7	"	Free S., Greco R.-Welter
Prasad, Ansuya		M	165.0	72.0	'36 • 8 • 17	Swimming and Diving Natation et Plongeurs	Springboard Diving
Singh, Sohan		M	164.0	61.0	'36 • 9 • 15	"	High Diving
Devi Singh	11	M	175.0	68.0	'32 • 8 • 10	Shooting Tir	Clay Pigeon
Karni Singh	10	M	175.0	106.0	'24 • 4 • 21	"	Clay Pigeon
Randhir Singh	504	M	.	.	'46 • 10 • 18	"	Clay Pigeon
IRAN IRAN							
Babakhanlou, Akbar	327	M	168.0	60.0	'39 • 8 • 4	Athletics Athlétisme	100m
Biatmaku, Fatmeh-Nazli	117	F	162.0	51.0	'45 • 9 • 16	"	High Jump
Geverkof, Juliet	118	F	180.0	70.0	'45 • 8 • 18	"	Shot Put, Discus Throw
Ghafourizadeh, Hossein	329	M	174.0	68.0	'43 • 6 • 16	"	400m, 800m, 1500m
Kohan-Sedgh, Janet	116	F	156.0	45.0	'45 • 5 • 19	"	100m
Mirzamolimadail K., S.J.	331	M	192.0	91.0	'38 • 2 • 14	"	Discus Throw
Safa-Mehr, Simin	115	F	147.0	58.0	'47 • 6 • 14	"	100m, Long Jump
Shahkhorenejad, A.	328	M	165.0	57.0	'30 • 10 • 27	"	200m
Yazdanpanah-Barughi, E.	330	M	173.0	68.0	'38 • 11 • 7	"	800m, 1500m, 5000m
Aghai, Naser	120	M	160.0	51.0	'44 • 1 • 20	Boxing Boxe	Fly
Aliakbarzadeh-Khoi, S.	121	M	165.0	54.0	'32 • 9 • 21	"	Bantam
Mahmoudpour-Roudsari, S.	124	M	171.0	71.0	'39 • 10 • 11	"	L. Middle
Nadimi-Ghasredashti, K.	123	M	173.0	63.5	'40 • 5 • 31	"	L. Welter
Pakandam, Hassan	122	M	175.0	60.0	'34 • 5 • 19	"	Light
Akhlaghi-Safa, Davoud	65	M	168.0	67.0	'44 • 4 • 16	Cycling Cyclisme	Road Ind., Team T. T.
Amini-Sarvar, Mashallah	66	M	165.0	69.0	'31 • 3 • 16	"	Road Ind., Team T. T.
Hosseini, Said-Esmail	67	M	169.0	68.0	'42 • 4 • 2	"	Road Ind., Team T. T.
Poudeh, Akbar	68	M	169.0	67.0	'32 • 3 • 13	"	Road Ind., Team T. T.
Almasi, Houshmand	133	M	178.0	78.0	'28 • 3 • 30	Fencing Escrime	Foil, Epee, Sabre, Ind., Team
Madani, Naser	132	M	166.0	58.0	'40 • 7 • 4	"	Foil, Sabre, Ind., Foil, Epee, Sabre, Team
Zarnegar, Bijhan	134	M	172.0	64.0	'40 • 3 • 25	"	Foil, Epee, Sabre, Ind., Team
Zarnegar, Shahpour	135	M	171.0	68.0	'29 • 3 • 25	"	Epee Ind., Foil, Epee, Sabre, Team
Amir-Asefi, Mansour	2	M	175.0	68.0	'33 • 7 • 19	Football	
Arab, Mostafa	4	M	178.0	72.0	'41 • 8 • 13	"	
Asli, Aziz	1	M	178.0	76.0	'37 • 4 • 4	"	
Biati-Eslam, Mohammad	17	M	170.0	70.0	'32 • 5 • 5	"	
Esmaili, Fariborz	14	M	160.0	56.0	'40 • 7 • 1	"	
Fanai, Gholam-Hossein	13	M	170.0	67.0	'42 • 5 • 14	"	
Ghelichkhani, Parviz	16	M	167.0	72.0	'44 • 11 • 27	"	
Habibi-Nakhmaghlai, H.	5	M	170.0	64.0	'39 • 2 • 7	"	
Jamali, Kambozia	8	M	166.0	57.0	'38 • 7 • 9	"	
Khodaparast, Mohamad H.	11	M	169.0	65.0	'38 • 5 • 27	"	
Latifi, Ebrahim	6	M	175.0	65.0	'39 • 1 • 27	"	
Mirzai, Ali	3	M	171.0	71.0	'42 • 10 • 9	"	
Mostafavi, Darush	15	M	165.0	58.0	'44 • 9 • 8	"	
Nirlou, Karam-Ali	12	M	175.0	60.0	'43 • 3 • 10	"	
Nourian, Gholam-Hossein	10	M	175.0	70.0	'35 • 3 • 16	"	
Saedi, Abdollah	7	M	163.0	63.0	'42 • 8 • 24	"	
Talebi, Jalal	9	M	186.0	74.0	'42 • 3 • 23	"	
Bazargan-Vali, Djalal	91	M	170.0	60.0	'39 • 12 • 23	Gymnastics Gymnastique	
Sorouri, Djamileh	52	F	147.0	38.0	'50 • 3 • 8	"	
Borumand, Manuchehr	158	M	175.0	110.0	'34 • 9 • 26	Weight-Lifting Haltérophilie	Heavy
Eslami, Rajabi	19	M	164.0	56.0	'37 • 4 • 27	"	Bantam
Estaki, Reza	103	M	172.0	82.5	'36 • 4 • 4	"	L. Heavy
Jalayer, Parviz	67	M	164.0	67.0	'39 • 10 • 27	"	Light

NAME NOM	NO. NO.	SEX SEXE	HEIGHT HAUTEUR	WEIGHT POIDS	DATE OF BIRTH DATE DE NAISSANCE	EVENT EPREUVE	
Nasiri-Seresht, Mohammad	7	M	148.0	52.0	'45 • 7 • 17	Weight-Lifting Haltérophilie	Bantam
Ebrahimiyan, Said-Hossein		M	173.0	70.0	'33 • 3 • 8	Wrestling Lutte	Greco R.-Light
Haydari, Said-Aliakbar		M	165.0	52.0	'41 • 7 • 14	"	Free S.-Fly
Khodabande, Abdollah		M	164.0	57.0	'36 • 8 • 28	"	Free S.-Bantam
Khoshoi, Ahmad		M	163.0	55.0	'39 • 3 • 2	"	Greco R.-Fly
Mehdzade Mansour		M	185.0	87.0	'38 • 8 • 14	"	Free S.-Middle
Mirmalek, Mohamad		M	168.0	66.0	'38 • 10 • 31	"	Greco R.-Feather
Movahed-Ardabili A.		M	174.0	70.0	'38 • 3 • 20	"	Free S.-Light
Saifpour-Sadabadi, M. E.		M	168.0	63.0	'38 • 7 • 1	"	Free S.-Feather
Sanatkaran, Mohamad-Ali		M	175.0	78.0	'37 • 3 • 18	"	Free S.-Welter
Shafizade, Syavash		M	165.0	60.0	'44 • 3 • 30	"	Greco R.-Bantam
Takhti, Gholam-Reza		M	180.0	100.0	'30 • 8 • 27	"	Free S.-L. Heavy
Zoughian, Asghar		M	175.0	78.0	'29 • 11 • 7	"	Greco R.-Welter
Fasihi, Manucher		M	164.0	59.0	'40 • 8 • 24	Swimming and Diving Natation et Plongeurs	Springboard Diving
Shonjani, Haydar		M	173.0	70.0	'45 • 12 • 28	"	100m Free
Kalani, Nohammad-Jafar	177	M	168.0	82.0	'28 • 5 • 1	Shooting Tir	Small Bore-3 P., Prone
Mobaser, Cholam-Hossein	178	M	175.0	68.0	'29 • 2 • 28	"	Small Bore-Prone
Momtahen, Nosratollah	179	M	175.0	60.0	'23 • 10 • 23	"	Free, Rapid Fire Pistol
Sharifi, Naser	176	M	172.0	71.0	'21 • 7 • 4	"	Small Bore-3 P., Prone
IRAQ IRAK							
Abdulsattar, Al-Shaikhli	337	M	.	.	'27 • 8 • 4	Athletics Athlétisme	4X400m
Adil, Bashir Al-Hatim	336	M	.	.	'27 • 8 • 6	"	4X400m
Kuraishi, Jasim Karim	333	M	175.0	75.0	'38 • 8 • 14	"	200m, 400m, 4X100m
Lazim Khalid Tawfik	335	M	.	.	'44 • 3 • 9	"	4X100m
Nashat, Mahir	339	M	.	.	'27 • 6 • 15	"	4X400m
Shawki, Abbod	338	M	.	.	'27 • 4 • 18	"	4X400m
Vincent, Samir Ambrose	334	M	185.0	85.0	'40 • 10 • 23	"	110m, 400m Hurdles, 4X100m, Long Jump, Triple Jump, Decathlon
Zalada, Khudher	332	M	178.0	76.0	'38 • 9 • 26	"	100m, 4X100m
Anwer, Yousuf	125	M	170.0	55.0	'36 • 8 • 25	Boxing Boxe	Feather
Khalid, Al-Karkhi	126	M	175.0	65.0	'40 • 8 • 15	"	L. Middle
Abbas, Aziz	68	M	169.0	67.0	'43 • 3 • 3	Weight-Lifting Haltérophilie	Light
Abduljabbar, Hadi	150	M	179.0	118.0	'30 • 1 • 26	"	Heavy
Juad, Abdulkhalic	151	M	180.0	123.0	'26 • 11 • 9	"	Heavy
Mahmoud, Shakir	127	M	173.0	90.0	'35 • 2 • 6	"	M. Heavy
Mansour, Zuhair	35	M	165.0	60.0	'44 • 4 • 9	"	Feather
Mohammed, Nadum	83	M	165.0	75.0	'39 • 6 • 11	"	Middle
Rashid, Mahmood	69	M	167.0	67.0	'42 • 12 • 4	"	Light
IRELAND IRLANDE							
Carroll, Noel	321	M	188.0	80.0	'41 • 12 • 7	Athletics Athlétisme	800m
Clifford, Basil	323	M	188.0	79.0	'38 • 4 • 20	"	1500m
Hogan, James Joseph	324	M	175.0	59.0	'32 • 5 • 28	"	5000m, 10000m, Marathon
Kyle, Maeve E. E.	114	F	159.0	57.0	'28 • 10 • 6	"	400m, 800m
Lawlor, John Francis	326	M	191.0	106.0	'34 • 3 • 14	"	Hammer Throw
McCleane, Derek George	322	M	179.0	68.0	'38 • 1 • 4	"	800m
O Riordan, Thomas B. M.	325	M	178.0	66.0	'37 • 7 • 12	"	5000m
Anderson, Brian	131	M	169.0	63.0	'39 • 5 • 22	Boxing Boxe	L. Welter
Fitzsimons, Patrick	129	M	160.0	56.0	'43 • 12 • 4	"	Feather
Mc Cafferty, John Anthony	127	M	165.0	50.0	'44 • 12 • 17	"	Fly
Mc Court, James Vincent	130	M	170.0	59.0	'44 • 1 • 24	"	Light
Rafter, Christopher	128	M	162.5	53.0	'37 • 2 • 24	"	Bantam
Bouchier-Hayes, J. D. M. N.	136	M	178.0	65.3	'44 • 12 • 17	Fencing Escrime	Foil, Epee, Sabre, Ind.
Ryan, Michael	137	M	181.0	71.0	'43 • 7 • 26	"	Foil, Epee, Sabre Ind.
Ryan, John		M	183.0	85.0	'34 • 9 • 9	Judo	All Weights
Feeney, Joseph		M	175.0	78.0	'37 • 2 • 28	Wrestling Lutte	Free S.-Welter
O'Connor, Sean		M	157.0	52.0	'37 • 7 • 26	"	Free S.-Fly
Brennan, Thomas		M	182.0	70.0	'40 • 1 • 29	Equestrian Sports Sport Equestre	Three-Day Event
Cameron, Anthony		M	176.5	63.5	'41 • 3 • 21	"	Three-Day Event
Freeman Jackson, Harry		M	178.0	64.0	'10 • 12 • 23	"	Three-Day Event
Freeman Jackson, Virginia		F	167.5	50.0	'39 • 3 • 16	"	Reserve

NAME NOM	NO. NO.	SEX SEXE	HEIGHT HAUTEUR	WEIGHT POIDS	DATE OF BIRTH DATE DE NAISSANCE	EVENT EPREUVE
Harty, John		M	178.0	64.0	'41 • 3 • 9	Equestrian Sports Sport Equestre
D'Alton, Robert Gordon		M	177.8	68.0	'23 • 2 • 22	Yachting
Flanagan, Patrick Leo		M	167.5	70.0	'09 • 9 • 22	"
Hooper, John Patrick A.		M	174.0	76.0	'34 • 12 • 13	"
Kelliher, Edward Joseph		M	188.0	89.0	'20 • 3 • 8	"
Maguire, Harry		M	180.0	82.5	'28 • 7 • 6	"
ISRAEL ISRAEL						
Gilad, Amos	341	M	173.0	62.0	'41 • 1 • 22	Athletics Athlétisme
Lamdani, Michal	120	F	172.0	64.0	'44 • 12 • 5	"
Psawkin, Levy	340	M	173.0	75.0	'39 • 4 • 12	"
Sydranski, Louise Marie	119	F	165.0	57.0	'41 • 11 • 11	"
Uriel, Gideon	342	M	184.0	.	'39 • 4 • 27	"
Melamed, Abraham		M	170.0	61.0	'44 • 9 • 25	Swimming and Diving Natation et Plongeoins
Shefa, Gershon		M	166.0	65.0	'43 • 5 • 18	"
Crystal, Hannan	180	M	172.0	85.0	'38 • 1 • 15	Shooting Tir
Kahan, Maxim	43	M	172.0	74.5	'18 • 1 • 25	"
Sirkis, Nehemia	181	M	175.0	90.0	'32 • 3 • 22	"
ITALY ITALIE						
Ambu, Antonio	362	M	167.0	59.0	'36 • 5 • 10	Athletics Athlétisme
Bello, Sergio	346	M	178.0	68.0	'42 • 5 • 6	"
Berruti, Livio	344	M	180.0	67.0	'39 • 5 • 19	"
Bianchi, Bruno	356	M	183.0	76.0	'39 • 2 • 8	"
Bianchi, Francesco	347	M	168.0	63.0	'40 • 1 • 15	"
Bogliatto, Mauro	358	M	188.0	76.0	'43 • 2 • 24	"
Cornacchia, Giovanni	348	M	186.0	78.0	'39 • 6 • 18	"
Dionisi, Renato	359	M	180.0	67.0	'47 • 11 • 21	"
Frinolli, Roberto	351	M	175.0	65.0	'40 • 11 • 13	"
Giani, Ito	343	M	176.0	67.0	'41 • 9 • 5	"
Giannattasio, Pasquale	353	M	174.0	74.0	'41 • 1 • 15	"
Iraldo, G. Paolo	357	M	180.0	53.0	'43 • 6 • 2	"
Jegher, Giorgio	363	M	178.0	65.0	'37 • 8 • 28	"
Lievore, Carlo	361	M	186.0	90.0	'37 • 11 • 10	"
Mazza, Giorgio	349	M	179.0	69.0	'39 • 9 • 23	"
Meconi, Silvano	360	M	188.0	109.0	'32 • 10 • 28	"
Morale, Salvatore	352	M	186.0	72.0	'38 • 11 • 4	"
Ottolina, Sergio	345	M	174.0	68.0	'42 • 11 • 23	"
Ottoz, Edy	350	M	179.0	68.0	'44 • 6 • 3	"
Pamich, Abdon	364	M	183.0	74.0	'33 • 10 • 3	"
Preatoni, Ennio	354	M	183.0	81.0	'44 • 12 • 11	"
Sar, Franco	365	M	188.0	88.0	'33 • 12 • 21	"
Sardi, Armando	355	M	173.0	70.0	'40 • 9 • 15	"
Trio, M. Vittoria	121	F	180.0	58.0	'47 • 12 • 18	"
Balatti, Fulvio		M	.	.	'38 • 1 • 31	Rowing Aviron
Bosatta, Renato		M	179.0	79.0	'38 • 2 • 11	"
Brunello, Sereno		M	183.0	81.0	'38 • 6 • 23	"
Clerici, Maurizio		M	192.0	94.0	'29 • 5 • 16	"
De Pedrina, Franco		M	184.0	83.0	'41 • 1 • 27	"
Galante, Giuseppe		M	177.0	79.0	'37 • 9 • 2	"
Giani, Dario		M	186.0	85.0	'38 • 5 • 8	"
Gilardi, Gian Pietro		M	183.0	83.0	'38 • 1 • 11	"
Glorioso, Francesco		M	180.0	80.0	'42 • 6 • 29	"
Melpignano, Antonio		M	183.0	83.0	'37 • 5 • 12	"
Mosetti, Paolo		M	189.0	81.0	'39 • 1 • 29	"
Polti, Pietro		M	179.0	77.0	'41 • 6 • 20	"
Savarin, Orlando		M	181.0	79.0	'38 • 9 • 6	"
Schiavon, Giuseppe		M	185.0	86.0	'42 • 3 • 1	"
Sgheiz, Luciano		M	181.0	82.0	'41 • 12 • 20	"
Sgheiz, Romano		M	188.0	92.0	'37 • 6 • 28	"
Spinola, Giovanni		M	165.0	53.0	'35 • 7 • 31	"

NAME NOM	NO. NO.	SEX SEXE	HEIGHT HAUTEUR	WEIGHT POIDS	DATE OF BIRTH DATE DE NAISSANCE	EVENT EPREUVE	
Stefanoni, Ivo		M	167.0	54.0	'36 • 6 • 5	Rowing Aviron	Eight, With Cox
Tagliapietra, Sergio		M	181.0	85.0	'35 • 6 • 1	"	Eight, With Cox
Trivini, Emilio		M	182.0	87.0	'38 • 4 • 5	"	Four, With Cox
Zucchi, Giovanni		M	186.0	92.0	'31 • 8 • 14	"	Four, Without Cox
Bertini, Franco	8	M	184.0	74.0	'38 • 8 • 28	Basket-Ball	
Bufalini, Sauro	13	M	200.0	95.0	'41 • 4 • 28	"	
Flaborea, Ottorino	11	M	198.0	101.0	'40 • 3 • 5	"	
Gavagnin, Giovanni	15	M	200.0	94.0	'36 • 9 • 15	"	
Giomo, Augusto	4	M	187.0	82.0	'40 • 2 • 3	"	
Lombardi, Gianfranco	6	M	194.0	100.0	'41 • 3 • 20	"	
Masini, Massimo	12	M	206.0	102.0	'45 • 5 • 9	"	
Pellanera, Justo	5	M	187.0	82.0	'38 • 3 • 12	"	
Pieri, Gianfranco	7	M	191.0	84.0	'37 • 2 • 6	"	
Sardagna, Gianfranco	10	M	190.0	81.0	'35 • 5 • 28	"	
Vianello, Gabriele	14	M	192.0	86.0	'38 • 5 • 6	"	
Vittori, Paolo	9	M	192.0	84.0	'38 • 5 • 31	"	
Arcari, Bruno	135	M	160.0	60.0	'42 • 1 • 1	Boxing Boxe	Light
Atzori, Fernando	132	M	158.0	51.0	'42 • 6 • 1	"	Fly
Bertini, Silvano	137	M	170.0	67.0	'40 • 3 • 27	"	Welter
Bruschini, Massimo	138	M	157.0	71.0	'42 • 8 • 30	"	L. Middle
Fasoli, Ermanno	136	M	167.0	63.5	'43 • 11 • 9	"	L. Welter
Girgenti, Giovanni	134	M	165.0	57.0	'42 • 12 • 18	"	Feather
Pinto, Cosimo	140	M	178.0	81.0	'43 • 3 • 14	"	L. Heavy
Ros, Giuseppe	141	M	180.0	81.0	'42 • 9 • 22	"	Heavy
Valle, Franco	139	M	177.0	75.0	'40 • 12 • 15	"	Middle
Zurlo, Franco	133	M	162.0	54.0	'40 • 10 • 4	"	Bantam
Agnisetta, Claudio	80	M	165.0	64.0	'43 • 12 • 29	Canoeing Canotage	Kayak 4
Beltrami, Cesare	81	M	175.0	75.0	'42 • 12 • 27	"	Kayak 2, 4
Pedroni, Angelo	82	M	175.0	71.0	'43 • 10 • 6	"	Kayak 4
Speroni, Alberto	83	M	178.0	78.0	'41 • 6 • 6	"	Reserve
Zilioli, Cesare	84	M	173.0	85.0	'38 • 4 • 21	"	Kayak 1, 2, 4
Andreoli, Severino	69	M	173.0	73.0	'41 • 1 • 8	Cycling Cyclisme	Road Ind., Team T. T.
Bianchetto, Sergio	94	M	176.0	76.0	'39 • 2 • 16	"	Reserve
Dalla Bona, Luciano	70	M	178.0	76.0	'43 • 11 • 8	"	Road Ind., Team T. T.
Damiano, Angelo	89	M	172.0	73.0	'38 • 9 • 30	"	Tandem Sprint
Gimondi, Felice	74	M	181.0	78.0	'42 • 9 • 29	"	Reserve
Grego, Virginio	85	M	171.0	63.0	'39 • 5 • 7	"	Team Pursuit
Guerra, Pietro	92	M	171.0	71.0	'43 • 6 • 28	"	Scratch Sprint, Road Team T. T.
Mantovani, Vincenzo	86	M	171.0	70.0	'41 • 10 • 17	"	Team Pursuit
Manza, Ferruccio	71	M	178.0	78.0	'43 • 4 • 26	"	Road Ind., Team T. T.
Pettenella, Giovanni	91	M	178.0	73.0	'43 • 3 • 28	"	1000m T. T., Scratch Sprint
Rancati, Carlo	87	M	175.0	74.0	'40 • 4 • 28	"	Team Pursuit
Roncaglia, Luigi	90	M	180.0	79.0	'43 • 6 • 10	"	Tandem Sprint
Testa, Franco	88	M	173.0	67.5	'38 • 2 • 7	"	Team Pursuit
Ursi, Giorgio	93	M	186.0	85.0	'42 • 9 • 1	"	Ind. Pursuit
Zanin, Mario	72	M	174.0	74.0	'40 • 7 • 3	"	Ind. Road
Breda, Giambattista	148	M	178.0	72.0	'31 • 7 • 21	Fencing Escrime	Epee Team
Calanchini, Giampaolo	153	M	178.0	73.0	'37 • 2 • 4	"	Sabre Team
Calarese, Wladimiro	154	M	170.0	70.0	'30 • 10 • 3	"	Sabre Team
Camber, Irene	138	F	169.0	63.0	'26 • 2 • 12	"	Foil Team
Chicca, Pierluigi	155	M	187.0	73.0	'37 • 12 • 22	"	Sabre Team
Colombetti, Bruna	139	F	173.5	67.0	'36 • 1 • 27	"	Foil Team
Curletto, Mario	143	M	175.0	62.0	'35 • 9 • 10	"	Foil Team
Delfino, Giuseppe	149	M	185.0	83.0	'21 • 11 • 22	"	Epee Team
Granieri, Nicola	144	M	182.0	80.0	'42 • 7 • 3	"	Foil Team
La Ragione, Pasquale	145	M	171.0	75.0	'43 • 11 • 28	"	Foil Team
Masciotta, Giovanna	140	F	169.0	64.0	'42 • 9 • 2	"	Foil Team
Milanesi, Gianguido	146	M	175.0	78.0	'35 • 6 • 26	"	Foil Team
Paolucci, Gianfranco	150	M	192.0	89.0	'34 • 2 • 18	"	Epee Team

NAME NOM	NO. NO.	SEX SEXE	HEIGHT HAUTEUR	WEIGHT POIDS	DATE OF BIRTH DATE DE NAISSANCE	EVENT EPREUVE	
Pellegrino, Alberto	151	M	177.0	74.0	'30 • 5 • 20	Fencing Escrime	Epee Team
Pinelli, Arcangelo	147	M	171.0	74.0	'44 • 3 • 20	"	Foil Team
Ragno, Antonella	141	F	172.0	57.0	'40 • 6 • 6	"	Foil Team
Ravagnan, Mario	156	M	180.0	73.0	'30 • 12 • 18	"	Sabre Team
Saccaro, Gianluigi	152	M	182.0	76.0	'38 • 12 • 29	"	Epee Team
Salvadori, Cesare	157	M	172.0	65.0	'41 • 9 • 22	"	Sabre Team
Sanguineti, Natalina	142	F	165.0	61.0	'40 • 12 • 25	"	Foil Team
Carminucci, Giovanni	41	M	169.0	66.0	'39 • 11 • 14	Gymnastics Gymnastique	
Carminucci, Pasquale	42	M	160.0	61.0	'37 • 8 • 29	"	
Cimnaghi, Luigi	43	M	169.0	65.0	'40 • 8 • 10	"	
Franceschetti, Bruno	44	M	166.0	66.0	'41 • 4 • 30	"	
Menichelh, Franco	45	M	162.0	60.0	'41 • 8 • 3	"	
Siligo, Vincenzo	47	M	164.0	63.0	'41 • 4 • 30	"	
Vicardi, Angelo	46	M	167.0	70.0	'36 • 10 • 9	"	
Grandi, Renzo	8	M	144.5	58.8	'34 • 4 • 29	Weight-Lifting Haltérophilie	Bantam
Mannironi, Sebastiano	44	M	159.7	58.3	'30 • 7 • 22	"	Feather
Carmeni, Bruno Giuseppe		M	165.5	69.7	'40 • 12 • 29	Judo	Light Weight
Gamba, Stefano		M	166.0	68.0	'39 • 8 • 24	"	Light Weight
Tempesta, Nicola		M	181.0	107.5	'35 • 6 • 28	"	Heavy Weight
Bulgarelli, Adelmo		M	182.5	99.0	'32 • 3 • 23	Wrestling Lutte	Greco R.-L. Heavy
De Vescovi, Gaetano		M	175.0	80.5	'37 • 11 • 14	"	Free S.-Welter
Fabra, Ignazio		M	158.5	56.5	'30 • 4 • 25	"	Greco R.-Fly
Grassi, Vincenzo		M	152.0	57.7	'38 • 11 • 17	"	Free S.-Fly
Toma, Michele		M	163.0	63.8	'38 • 8 • 9	"	Greco R.-Bantam
Beneck, Daniela		F	170.0	62.0	'46 • 7 • 8	Swimming and Diving Natation et Plongeurs	100m, 400m, 4X100m Free
Bianchi, Bruno		M	181.0	75.0	'43 • 9 • 26	"	100m, 4X100m, 4X200m Free, 4X100m Medley
Boscaini, Pietro		M	188.0	77.0	'47 • 4 • 22	"	100m, 4X100m, 4X200m Free
Cagnotto, Franco		M	161.0	77.0	'47 • 6 • 2	"	Springboard, High Diving
Caramelli, Cesare		M	173.0	68.0	'38 • 10 • 26	"	200m Breast
Cecchi, Anna Maria		F	163.0	53.0	'43 • 4 • 24	"	100m Butterfly
De Gregorio, Sergio		M	178.0	76.0	'46 • 2 • 24	"	100m, 400m, 4X100m, 4X200m Free
Delia Savia, Ezio		M	184.0	78.0	'42 • 6 • 24	"	200m Back
Dennerlein, Costantino		M	180.0	82.0	'32 • 12 • 28	"	200m Breast
Dennerlein, Federico		M	186.0	87.0	'36 • 3 • 14	"	4X200m Free
Dibiasi, Carlo		M	170.0	80.0	'09 • 10 • 19	"	High Diving
Dibiasi, Klaus		M	182.0	75.0	'47 • 10 • 6	"	Springboard, High Diving
Fossati, Giampiero		M	168.0	67.0	'44 • 4 • 13	"	200m Butterfly
Gross, Gian Corrado		M	174.0	79.0	'42 • 2 • 11	"	200m Breast, 4X100m Medley
Orlando, Giovanni		M	168.0	71.0	'45 • 2 • 2	"	400m, 4X100m, 4X200m Free
Pacifici, Maria Christina		F	170.0	63.0	'45 • 8 • 5	"	400m, 4X100m Free
Rastrelli, Antonio		M	170.0	73.0	'45 • 1 • 15	"	200m Butterfly, 4X100m Medley
Rora, Chiaffredo		M	182.0	83.0	'45 • 3 • 5	"	200m Back, 4X100m Free, 4X100m Medley
Sacchi, Mara		F	170.0	63.0	'48 • 11 • 3	"	100m, 4X100m Free
Saini, Paola		F	162.0	56.0	'45 • 10 • 11	"	100m, 400m, 4X100m Free
Spangaro, Pierpaolo		M	181.0	77.0	'42 • 6 • 26	"	400m Free
Zunini, Paola		F	160.0	58.0	'49 • 6 • 3	"	4X100m Free
Ottaviani, Alfonso	26	M	183.0	72.0	'37 • 10 • 5	Modern Pentathlon Pentathlon Moderne	
Angioni, Paolo		M	.	.	'38 • 1 • 22	Equestrian Sports Sport Equestre	Three-Day Event
Angioni, Stefano		M	.	.	'39 • 9 • 18	"	Jumping Grand Prix
Argenton, Alessandro		M	.	.	'37 • 2 • 11	"	Three-Day Event
Checconi, Mauro		M	.	.	'43 • 3 • 1	"	Three-Day Event
D'Inzeo, Piero		M	.	.	'23 • 3 • 4	"	Jumping Grand Prix
D'Inzeo, Raimondo		M	.	.	'25 • 2 • 8	"	Jumping Grand Prix
Mancinelli, Graziano		M	.	.	'37 • 2 • 18	"	Jumping Grand Prix
Ravano, Giuseppe		M	.	.	'43 • 2 • 5	"	Three-Day Event
Amicosante, Ugo	183	M	170.0	76.0	'30 • 8 • 8	Shooting Tir	Rapid Fire Pistol
Liverzani, Giovanni	184	M	181.0	94.0	'33 • 5 • 5	"	Rapid Fire Pistol
Mattarelli, Ennio	4	M	180.0	80.0	'28 • 8 • 5	"	Clay Pigeon
Rossini, Lliano	5	M	172.0	85.0	'27 • 5 • 17	"	Clay Pigeon

NAME NOM	NO. NO.	SEX SEXE	HEIGHT HAUTEUR	WEIGHT POIDS	DATE OF BIRTH DATE DE NAISSANCE	EVENT EPREUVE	
Simoni, Ugo	182	M	173.0	69.0	'38 • 6 • 3	Shooting Tir	Free Pistol
Bardi, Danio		M	180.0	77.0	'37 • 5 • 23	Water Polo	
Cevasco, Mario		M	183.0	72.0	'38 • 12 • 18	"	
D'Altrui, Giuseppe		M	185.0	84.0	'34 • 4 • 7	"	
Dennerlein, Federico		M	186.0	87.0	'36 • 3 • 14	"	
Guerrini, Giancarlo		M	180.0	79.0	'39 • 12 • 29	"	
Lavoratori, Franco		M	179.0	79.0	'41 • 3 • 15	"	
Lonzi, Gianni		M	182.0	72.0	'38 • 8 • 4	"	
Merello, Eugenio		M	180.0	71.0	'40 • 3 • 12	"	
Parmegiani, Rosario		M	174.0	79.0	'37 • 3 • 12	"	
Pizzo, Eraldo		M	180.0	82.0	'38 • 4 • 21	"	
Rossi, Dante		M	191.0	89.0	'36 • 8 • 28	"	
Spinola, Alberto		M	183.0	80.0	'43 • 5 • 11	"	
Bianchi, Bruno		M	172.0	75.0	'04 • 5 • 2	Yachting	Reserve
Capio, Mario		M	176.0	75.0	'24 • 8 • 3	"	F. Dutchman
Croce, Andrea Giuseppe		M	179.0	84.0	'14 • 12 • 11	"	Reserve
Croce, Luigi		M	179.0	78.0	'40 • 11 • 27	"	Star
Furlan, Sergio		M	175.0	77.0	'40 • 2 • 29	"	Dragon
Minervini, Massimo		M	183.0	86.0	'39 • 3 • 30	"	5.5m
Pelaschiar, Annibale		M	174.0	102.0	'12 • 1 • 25	"	Dragon
Petronio, Brunc		M	182.0	86.0	'36 • 1 • 30	"	5.5m
Rolandi, Caplo		M	180.0	82.0	'26 • 7 • 2	"	Reserve
Saidelli, Luigi		M	180.0	76.0	'39 • 1 • 12	"	Star
Sartori, Marco		M	175.0	74.0	'38 • 12 • 14	"	F. Dutchman
Sorrentino, Sergio		M	184.0	82.0	'24 • 7 • 19	"	Dragon
Straulino, Agostino		M	179.0	86.0	'14 • 10 • 10	"	5.5m
IVORY COAST COTE-D'IVOIRE							
Adjima Beche, Denos	368	M	168.0	56.0	'44 •	Athletics Athlétisme	1500m
Coulibaly, Yoyaga Dit F.	367	M	172.0	67.0	'39 • 1 • 20	"	400m
Ekonian Toffey, Jean	370	M	176.0	57.0	'35 •	"	3000m S. C.
Kone, Gaoussou	366	M	177.0	74.0	'43 •	"	100m
Kragbe, Segui Denis	371	M	197.0	100.0	'38 •	"	Shot Put, Discus Throw
Maki, Simbara Demeble	369	M	182.0	76.0	'38 • 10 • 12	"	110m Hurdles
Achy-Assi, Gabriel	142	M	166.0	60.5	'38 •	Boxing Boxe	Light
Hie Toh, Boniface	143	M	172.0	63.0	'36 •	"	Welter
Nguia, Firmin	144	M	180.0	80.0	'40 • 1 • 2	"	L. Heavy
JAMAICA JAMAIQUE							
Charlton, Vilma B.	125	F	161.0	54.5	'46 • 12 • 7	Athletics Athlétisme	4X100
Clayton, Wellesley K.	379	M	172.5	76.0	'38 • 8 • 25	"	4X100m, Long Jump
Headley, Lynsworth W.	373	M	185.0	75.0	'43 • 4 • 7	"	100m, 4X100m
Hoilette, Rupert L.	377	M	170.0	63.5	'46 • 6 • 24	"	400m, 4X400m
Johnson, Dennis O.	372	M	180.0	75.0	'39 • 5 • 6	"	100m, 4X100m
Kahn, Lawrence G.	376	M	168.5	61.0	'43 • 6 • 14	"	400m, 4X400m
Kerr, George E.	375	M	177.5	71.5	'37 • 10 • 16	"	400m, 800m, 4X400m
Mair, Adlin V.	124	F	165.0	53.5	'41 • 11 • 15	"	200m, 4X100m
McNeil, Pablo S.	374	M	175.0	73.0	'39 • 9 • 12	"	100m, 200m, 4X100m
Morris, Una L.	123	F	172.5	58.0	'47 • 1 • 17	"	200m, 400m, 4X100m
Myton, Neville F.	378	M	182.5	68.0	'46 • 5 • 28	"	800m, 1500m, 4X400m
Robinson, Patrick D.	300	M	185.0	82.0	'43 • 11 • 12	"	4X100m
Smith, Carmen L.	122	F	161.0	52.0	'43 • 2 • 16	"	80m Hurdles, 100m, 4X100m
Spence, Malcolm E.	382	M	172.5	67.0	'36 • 1 • 2	"	4X400m
Spence, Melville	381	M	174.0	70.5	'36 • 1 • 2	"	4X400m
Elliott, John Alphonso	145	M	170.2	69.9	'31 • 6 • 8	Boxing Boxe	L. Middle
Holmes, Ronald	146	M	177.5	80.0	'34 • 11 • 22	"	Heavy
Bridge, Roy Anthony	193	M	185.0	108.0	'21 • 2 • 4	Shooting Tir	Free Pistol
Henriques, Steve Michael		M	.	.	'44 • 6 • 2	Yachting	Dragon
Kirkconnell, B. G.		M	.	.	'17 • 5 • 6	"	Dragon
Taylor, Earl		M	.	.	'32 • 7 • 22	"	Dragon

NAME NOM	NO. NO.	SEX SEXE	HEIGHT HAUTEUR	WEIGHT POIDS	DATE OF BIRTH DATE DE NAISSANCE	EVENT EPREUVE
JAPAN JAPON						
Amano, Yoshihiro	809	M	168.0	62.0	'42 • 10 • 16	Athletics Athlétisme
Asai, Kiyoshi	805	M	167.0	60.0	'40 • 2 • 6	"
Ejiri, Tadamasu	836	M	174.0	65.0	'34 • 5 • 11	"
Ezoe, Reiko	244	F	154.0	43.0	'42 • 6 • 20	"
Funai, Teruo	793	M	168.0	62.0	'38 • 4 • 28	"
Hayase, Hirotada	789	M	174.0	65.0	'40 • 9 • 5	"
Hayashi, Hisao	807	M	178.0	70.0	'41 • 8 • 21	"
Honda, Toru	808	M	167.0	62.0	'41 • 7 • 5	"
Iijima, Hideo	788	M	175.0	75.0	'44 • 1 • 1	"
Iijima, Keiki	799	M	173.0	62.0	'38 • 5 • 16	"
Inokuchi, Takako	245	F	162.0	65.0	'42 • 2 • 4	"
Ishiguro, Noboru	831	M	165.0	54.0	'32 • 8 • 2	"
Ishikawa, Junji	804	M	174.0	63.0	'45 • 7 • 13	"
Itokawa, Teruo	822	M	178.0	86.5	'40 • 10 • 26	"
Iwashita, Satsuo	792	M	167.0	53.0	'41 • 8 • 18	"
Izawa, Makiko	240	F	162.0	55.0	'46 • 8 • 15	"
Kamata, Masaru	737	M	172.0	67.0	'40 • 4 • 21	"
Kanai, Hideta	825	M	177.0	75.0	'38 • 5 • 7	"
Kaneko, Sohei	823	M	175.0	78.0	'37 • 8 • 10	"
Kasahara, Shohei	828	M	177.0	83.0	'39 • 7 • 21	"
Katayama, Misako	253	F	163.0	63.0	'44 • 4 • 11	"
Kawazu, Koro	817	M	170.0	62.0	'40 • 11 • 25	"
Kimihara, Kenji	829	M	167.0	56.0	'41 • 3 • 20	"
Kisaki, Masako	242	F	160.0	50.0	'43 • 11 • 7	"
Kishimoto, Sachiko	248	F	154.0	45.0	'36 • 4 • 25	"
Koumaru, Emiko	249	F	173.0	57.0	'46 • 11 • 17	"
Kuribayashi, Kiue	833	M	164.0	59.0	'34 • 5 • 15	"
Miki, Takashi	824	M	173.0	76.0	'39 • 4 • 27	"
Miwa, Sumio	835	M	170.0	62.0	'32 • 7 • 25	"
Miyamoto, Etsuko	243	F	159.0	51.0	'43 • 8 • 23	"
Miyazaki, Kinya	811	M	175.0	62.0	'38 • 11 • 3	"
Morimoto, Mamoru	790	M	177.0	66.0	'39 • 7 • 11	"
Morita, Hisao	814	M	170.0	64.0	'39 • 9 • 25	"
Muro, Yojiro	806	M	175.0	70.0	'39 • 7 • 5	"
Naito, Yasuo	832	M	164.0	53.0	'42 • 11 • 18	"
Obonai, Seiko	250	F	172.0	72.0	'40 • 2 • 16	"
Ogawa, Kiyoko	241	F	161.0	50.0	'46 • 11 • 4	"
Ogushi, Keiji	798	M	173.0	63.0	'34 • 4 • 3	"
Okamoto, Noboru	827	M	177.0	90.0	'37 • 2 • 19	"
Okazaki, Takayuki	819	M	168.0	57.0	'40 • 3 • 28	"
Okuzawa, Zenji	803	M	166.0	53.0	'37 • 11 • 26	"
Ota, Tomio	821	M	178.0	60.0	'36 • 10 • 21	"
Otsubo, Masashi	813	M	169.0	63.0	'38 • 6 • 18	"
Saito, Kazuo	834	M	165.0	55.0	'42 • 6 • 26	"
Sakurai, Koji	820	M	172.0	64.0	'36 • 2 • 18	"
Saruwatari, Taketsugu	801	M	171.0	59.0	'42 • 12 • 23	"
Sato, Hiroko	252	F	160.0	55.0	'39 • 6 • 10	"
Sato, Miho	246	F	162.0	50.0	'48 • 4 • 21	"
Sugawara, Takeo	826	M	170.0	75.0	'38 • 5 • 23	"
Sugioka, Kuniyoshi	812	M	182.0	70.0	'42 • 2 • 10	"
Suzuki, Shosuke	837	M	179.0	73.0	'36 • 11 • 11	"
Takahashi, Miyuki	254	F	162.0	53.0	'46 • 9 • 25	"
Takayanagi, Satoshi	818	M	170.0	70.0	'38 • 7 • 16	"
Tanaka, Akira	797	M	183.0	72.0	'42 • 3 • 10	"
Terasawa, Toru	830	M	163.0	54.0	35 • 1 • 4	"
Torii, Mitsuko	247	F	168.0	58.0	'43 • 8 • 9	"
Torii, Yoshimasa	815	M	175.0	63.0	'42 • 4 • 14	"
Tsuburaya, Kokichi	795	M	163.0	54.0	'40 • 5 • 13	"
Watanabe, Kazumi	794	M	167.0	52.0	'35 • 12 • 25	"

NAME NOM	NO. NO.	SEX SEXE	HEIGHT HAUTEUR	WEIGHT POIDS	DATE OF BIRTH DATE DE NAISSANCE	EVENT EPREUVE	
Yamada, Hiroomi	816	M	180.0	72.0	'42 • 3 • 4	Athletics Athlétisme	Long Jump
Yamaguchi, Toichi	791	M	179.0	65.0	'41 • 12 • 15	"	1500m
Yasuda, Hirokazu	796	M	172.0	66.0	'36 • 5 • 31	"	110m Hurdles
Yoda, Ikuko	239	F	164.0	53.0	'38 • 9 • 30	"	100m, 80m Hurdles, 4X100m
Yokomizo, Saburo	802	M	162.0	55.0	'39 • 12 • 9	"	3000m S. C.
Yokoyama, Hiroko	251	F	166.0	74.0	'36 • 2 • 11	"	Discus Throw
Yoshida, Masami	810	M	182.0	67.0	'46 • 1 • 17	"	4X400m
Yui, Kiyoo	800	M	173.0	63.0	'43 • 4 • 21	"	400m Hurdles
Aida, Hideaki		M	175.0	71.0	'43 • 8 • 25	Rowing Aviron	Four, With Cox
Hamada, Toshihiro		M	183.0	82.0	'41 • 10 • 23	"	Pair, With Cox
Hasegawa, Shin		M	183.0	78.0	'40 • 2 • 11	"	Eight, With Cox
Honma, Yasuji		M	181.0	76.0	'43 • 10 • 2	"	Four, Without Cox
Hosoya, Susumu		M	179.0	70.0	'42 • 2 • 25	"	Double Sculls
Ihara, Katsuhiko		M	178.0	76.0	'43 • 1 • 13	"	Pair, With Cox
Ishikawa, Hajime		M	177.0	79.0	'41 • 2 • 20	"	Eight, With Cox
Ito, Tsugio		M	179.5	78.0	'42 • 1 • 28	"	Eight, With Cox
Kasagi, Satoomi		M	180.5	78.0	'46 • 1 • 9	"	Single, Double Sculls
Kikuchi, Ryuzo		M	178.0	77.0	42 • 4 • 21	"	Eight, With Cox
Kimura, Bunzo		M	175.0	75.0	'42 • 4 • 20	"	Four, Without Cox
Kogo, Takao		M	179.0	76.0	'41 • 5 • 15	"	Pair, Without Cox
Kurosaki, Narimasa		M	183.0	78.0	'43 • 2 • 2	"	Pair, Without Cox
Mandai, Osamu		M	166.0	50.0	'42 • 10 • 6	"	Four, Eight, With Cox,
Matsuda, Yukio		M	181.3	74.0	'42 • 3 • 12	"	Four, With Cox
Miki, Shunsuke		M	177.0	74.0	'44 • 2 • 6	"	Four, Without Cox
Miyano, Koichi		M	183.0	78.0	'42 • 12 • 18	"	Eight, With Cox
Murase, Yasushi		M	170.0	65.0	'41 • 10 • 25	"	Single, Double Sculls
Oe, Hideo		M	175.6	74.0	'44 • 1 • 8	"	Four, Eight, With Cox
Ogasawara, Tsuneo		M	181.0	80.0	'42 • 7 • 30	"	Eight, With Cox
Onishi, Yoshihiro		M	182.0	80.0	'41 • 6 • 21	"	Eight, With Cox
Sato, Naoji		M	179.3	75.0	'42 • 10 • 31	"	Eight, With Cox
Takatsuki, Masahiro		M	165.0	50.0	'42 • 2 • 8	"	Pair, With Cox
Tsukamoto, Kojyu		M	176.0	75.0	'42 • 2 • 1	"	Four, Without Cox
Yamanouchi, Masakatsu		M	178.0	75.0	'42 • 6 • 1	"	Four, Eight, With Cox
Yoshino, Noriichi		M	164.0	50.0	'43 • 4 • 8	"	Four, Eight, With Cox
Bai Katsuo	9	M	182.0	77.0	'40 • 11 • 29	Basket-Ball	
Egawa, Yoshitaka	12	M	184.6	80.0	'42 • 12 • 20	"	
Fujie, Seiji	10	M	192.0	79.0	'41 • 6 • 15	"	
Kaiho, Nobuo	11	M	168.0	65.0	'41 • 12 • 21	"	
Kodama, Akira	15	M	196.0	78.5	'44 • 3 • 20	"	
Masuda, Takashi	8	M	183.0	75.0	'40 • 8 • 15	"	
Moroyama, Fumihiko	13	M	186.0	78.0	'43 • 8 • 14	"	
Nakamura, Kunihiko	7	M	188.0	77.0	'39 • 9 • 24	"	
Nara, Setsuo	4	M	175.0	68.0	'36 • 12 • 16	"	
Shiga, Masashi	6	M	176.0	74.0	'39 • 1 • 28	"	
Tsunoda, Katsuji	14	M	194.5	78.5	'43 • 9 • 28	"	
Wakabayashi, Kaoru	5	M	179.0	73.0	'38 • 8 • 19	"	
Hamada, Kichijiro	152	M	178.0	67.0	'42 • 10 • 25	Boxing Boxe	Welter
Maruyama, Tadayuki	155	M	180.0	82.0	'42 • 1 • 29	"	Heavy
Masuda, Koji	153	M	179.0	71.0	'44 • 2 • 1	"	L. Middle
Sakurai, Takao	148	M	164.0	54.0	'41 • 9 • 25	"	Bantam
Shiratori, Kanemaru	150	M	165.0	60.0	'42 • 2 • 3	"	Light
Takayama, Masataka	149	M	173.0	57.0	'45 • 10 • 30	"	Feather
Tenma, Hitoshi	154	M	173.0	75.0	'42 • 6 • 3	"	Middle
Yonekura, Takatsugu	151	M	172.0	63.5	'44 • 10 • 3	"	L. Welter
Yoshino, Shuta	147	M	162.0	52.0	'43 • 3 • 20	"	Fly
Eto, Izumi	85	M	173.0	73.0	'35 • 7 • 10	Canoeing Canotage	Kayak 4
Higashiyama, Hideo	86	M	170.0	67.0	'42 • 5 • 23	"	Kayak 1
Honda, Daisaburo	87	M	179.0	77.0	'35 • 2 • 17	"	Canadian 2
Iwamura, Shunichi	88	M	172.0	72.0	'40 • 10 • 23	"	Canadian 2

NAME NOM	NO. NO.	SEX SEXE	HEIGHT HAUTEUR	WEIGHT POIDS	DATE OF BIRTH DATE DE NAISSANCE	EVENT EPREUVE
Kashimura, Katsufusa	89	M	174.0	66.0	'42 • 10 • 19	Canoeing Canotage
Kobayashi, Hideo	90	M	169.0	70.0	'43 • 1 • 28	"
Okamoto, Keiko	91	F	160.0	56.0	'45 • 6 • 13	"
Oshima, Hiroko	92	F	160.3	59.0	'43 • 11 • 3	"
Sato, Tadamasa	93	M	174.0	72.0	'41 • 5 • 20	"
Shoji, Yoshio	94	M	172.5	68.0	'43 • 12 • 11	"
Sumimoto, Tomio	95	M	168.0	70.0	'45 • 8 • 20	"
Umezawa, Yuji	96	M	177.0	72.0	'45 • 10 • 16	"
Akamatsu, Toshiro	75	M	162.0	56.0	'41 • 8 • 28	Cycling Cyclisme
Fukuhara, Hirotsugu	103	M	163.0	62.0	'45 • 3 • 21	"
Hotogi, Norio	96	M	168.0	63.0	'43 • 11 • 20	"
Ito, Fujio	97	M	177.0	75.0	'45 • 2 • 24	"
Kato, Takehisa	68	M	167.0	60.0	'41 • 12 • 8	"
Kawauchi, Tsuyoshi	104	M	173.0	71.0	'45 • 1 • 4	"
Madarame, Hideo	100	M	168.0	65.0	'44 • 1 • 12	"
Omiya, Masashi	76	M	167.0	67.0	'38 • 3 • 10	"
Sato, Katsuhiku	102	M	166.0	66.0	'43 • 5 • 18	"
Shimura, Yoshio	70	M	168.0	65.0	'40 • 9 • 23	"
Takahashi, Kosaku	98	M	167.0	63.0	'44 • 7 • 25	"
Teshima, Toshimitsu	101	M	175.0	70.0	'42 • 12 • 12	"
Tsuji, Masanori	77	M	172.0	65.0	'46 • 3 • 24	"
Yamafuji, Hiromi	99	M	164.0	62.0	'44 • 10 • 23	"
Yamao, Hiroshi	78	M	170.0	64.0	'43 • 12 • 10	"
Araki, Toshiaki	169	M	175.0	67.0	'42 • 5 • 31	Fencing Escrime
Funamizu, Mitsuyuki	170	M	164.0	60.0	'33 • 9 • 7	"
Kitao, Teruhiro	172	M	167.6	61.0	'37 • 6 • 5	"
Komori, Yoshie	161	F	163.0	62.0	'37 • 5 • 10	"
Mano, Kazuo	165	M	168.0	60.0	'40 • 3 • 8	"
Minatoi, Katsutada	167	M	167.8	57.0	'39 • 8 • 1	"
Okawa, Heizaburo	163	M	170.0	60.0	'39 • 12 • 2	"
Owada, Tomoko	159	F	155.0	58.0	'41 • 3 • 15	"
Shibata, Seiji	171	M	173.0	58.0	'38 • 2 • 3	"
Shimizu, Fujio	164	M	167.0	55.0	'40 • 1 • 29	"
Tabuchi, Kazuhiko	162	M	178.0	67.0	'36 • 10 • 15	"
Takeuchi, Yoshie	158	F	161.5	53.0	'32 • 5 • 18	"
Tejima, Takeshi	168	M	170.0	58.0	'41 • 9 • 5	"
Toda, Sosuke	166	M	166.0	55.0	'41 • 1 • 11	"
Yasui, Tamiko	160	F	156.0	50.5	'42 • 6 • 3	"
Hiraki, Ryuzo	4	M	166.0	60.0	'31 • 10 • 7	Football
Hosaka, Tsukasa	1	M	175.0	67.0	'37 • 3 • 3	"
Kamamoto, Kunishige	15	M	178.0	75.0	'44 • 4 • 15	"
Kamata, Mitsuo	8	M	177.0	69.0	'37 • 12 • 16	"
Kami, Hisao	7	M	176.0	70.0	'41 • 6 • 28	"
Katayama, Hiroshi	2	M	170.0	70.0	'40 • 5 • 28	"
Kawabuchi, Saburo	12	M	172.0	72.0	'36 • 12 • 3	"
Miyamoto, Masakatsu	3	M	172.0	69.0	'38 • 7 • 4	"
Miyamoto, Teruki	16	M	172.0	67.0	'40 • 12 • 26	"
Mori, Takaji	11	M	173.0	60.0	'43 • 11 • 24	"
Ogi, Aritatsu	10	M	177.0	71.0	'42 • 12 • 10	"
Sugiyama, Ryuichi	18	M	168.0	65.0	'41 • 7 • 4	"
Suzuki, Ryoza	6	M	173.0	65.0	'39 • 9 • 20	"
Tomizawa, Kiyoshi	9	M	170.0	65.0	'43 • 12 • 3	"
Tsugitani, Shozo	17	M	167.0	61.0	'40 • 6 • 25	"
Watanabe, Masashi	14	M	170.0	63.0	'36 • 1 • 11	"
Yaegashi, Shigeo	13	M	170.0	65.0	'33 • 3 • 24	"
Yamaguchi, Yoshitada	5	M	167.0	61.0	'44 • 9 • 28	"
Yokoyama, Kenzo	21	M	175.0	72.0	'43 • 10 • 21	"
Aiba, Yoshihiro	217	M	166.0	62.0	'41 • 4 • 4	Gymnastics Gymnastique
Aihara, Toshiko	32	F	148.0	44.5	'39 • 6 • 3	"

NAME NOM	NO. NO.	SEX SEXE	HEIGHT HAUTEUR	WEIGHT POIDS	DATE OF BIRTH DATE DE NAISSANCE	EVENT EPREUVE	
Chiba, Ginko	36	F	150.0	43.0	'38 • 2 • 25	Gymnastics	
Endo, Yukio	212	M	161.0	58.0	'37 • 1 • 18	Gymnastique	
Hayata, Takuji	216	M	160.0	58.0	'40 • 10 • 10	"	
Ikedo, Keiko	31	F	155.0	52.0	'33 • 11 • 11	"	
Mitsukuri, Takashi	214	M	161.0	60.0	'39 • 2 • 19	"	
Nakamura, Taniko	31	F	158.0	46.0	'43 • 3 • 23	"	
Ono, Kiyoko	33	F	157.0	50.0	'36 • 2 • 4	"	
Ono, Takashi	211	M	160.0	59.0	'31 • 7 • 26	"	
Shibuya, Taki	37	F	157.0	52.0	'41 • 1 • 2	"	
Tsuji, Hiroko	35	F	151.0	47.0	'38 • 11 • 29	"	
Tsurumi, Shuji	213	M	160.0	52.0	'38 • 1 • 29	"	
Yamashita, Haruhiro	215	M	165.0	60.0	'38 • 11 • 15	"	
Fukuda, Hiroshi	45	M	157.0	61.5	'42 • 5 • 27	Weight-Lifting	Feather
Furuyama, Yukio	20	M	155.0	58.0	'38 • 7 • 26	Haltérophilie	Bantam
Ichinoseki, Shiro	21	M	158.0	58.0	'44 • 1 • 24	"	Bantam
Miwa, Sadahiro	94	M	166.0	77.0	'41 • 5 • 16	"	Middle
Miyake, Yoshinobu	46	M	154.0	60.0	'39 • 12 • 24	"	Feather
Ohuchi, Masashi	95	M	164.0	78.0	'43 • 8 • 28	"	Middle
Yamazaki, Hiroshi	10	M	164.0	67.5	'37 • 6 • 14	"	Light
Hashimoto, Seiji	18	M	169.0	59.0	'42 • 5 • 15	Hockey	
Iwahashi, Kunio	5	M	176.0	63.0	'39 • 1 • 3	"	
Kaoku, Shigeo	4	M	164.5	58.0	'42 • 7 • 29	"	
Kihara, Seiji	11	M	170.0	61.0	'41 • 1 • 15	"	
Matsumoto, Norihiko	12	M	166.5	67.0	'44 • 3 • 5	"	
Miwa, Hiroshi	1	M	168.0	63.0	'40 • 9 • 2	"	
Okabe, Michio	10	M	167.5	62.0	'40 • 9 • 10	"	
Takashima, Akio	3	M	173.0	65.0	'42 • 4 • 15	"	
Takeda, Morihiro	13	M	170.0	60.0	'42 • 8 • 14	"	
Takizawa, Kenji	7	M	164.0	57.0	'40 • 6 • 8	"	
Tanaka, Hiroshi	9	M	174.0	65.0	'41 • 12 • 20	"	
Wakabayashi, Tetsuya	15	M	173.0	65.0	'42 • 7 • 3	"	
Watanabe, Yutaka	16	M	164.5	55.0	'45 • 2 • 7	"	
Yamaguchi, Junichi	8	M	162.0	58.0	'40 • 3 • 30	"	
Yamaoka, Toshihiko	6	M	160.0	57.0	'41 • 9 • 11	"	
Yoshimura, Minoru	17	M	165.0	59.0	'45 • 1 • 1	"	
Yuzaki, Katsuhiko	14	M	169.0	63.0	'44 • 1 • 8	"	
Yuzaki, Tsuneya	2	M	173.0	67.0	'41 • 2 • 10	"	
Inokuma, Isao		M	173.0	88.0	'38 • 2 • 4	Judo	Heavy Weight
Kaminaga, Akio		M	179.4	102.0	'36 • 12 • 22	"	All Weights
Nakatani, Takehide		M	165.0	69.0	'41 • 7 • 9	"	Light Weight
Okano, Isao		M	171.0	80.0	'44 • 1 • 20	"	Middle Weight
Fujita, Tokuaki		M	165.0	73.0	'41 • 1 • 10	Wrestling	Greco R.-Light
Hanahara, Tsutomu		M	159.5	57.5	'40 • 1 • 3	Lutte	Greco R.-Fly
Hiraki, Kenjiro		M	178.0	84.0	'40 • 2 • 17	"	Greco R.-Middle
Horiuchi, Iwao		M	163.0	73.0	'41 • 12 • 9	"	Free S.-Light
Ichiguchi, Masamitsu		M	162.0	62.0	'40 • 1 • 12	"	Greco R.-Bantam
Kawano, Shunichi		M	178.0	90.0	'36 • 11 • 29	"	Free S.-L. Heavy
Kazama, Sadao		M	174.0	80.0	'40 • 10 • 25	"	Greco R.-Welter
Nakaura, Akira		M	177.0	94.0	'35 • 11 • 3	"	Greco R.-L. Heavy
Saito, Masanori		M	179.0	98.0	'42 • 8 • 7	"	Free S.-Heavy
Sakurama, Koji		M	158.0	64.0	'38 • 2 • 12	"	Greco R.-Feather
Sasaki, Tatsuo		M	180.0	86.0	'42 • 9 • 24	"	Free S.-Middle
Sugiyama, Tsuneharu		M	175.0	118.0	'40 • 7 • 23	"	Greco R.-Heavy
Uetake, Yojiro		M	165.0	61.0	'43 • 1 • 12	"	Free S.-Bantam
Watanabe, Osamu		M	160.0	65.0	'40 • 10 • 21	"	Free S.-Feather
Watanabe, Yasuo		M	175.0	80.0	'44 • 2 • 21	"	Free S.-Welter
Yoshida, Yoshikatsu		M	161.0	56.0	'41 • 10 • 30	"	Free S.-Fly
Arimitsu, Yosuke		M	165.0	59.0	'43 • 11 • 16	Swimming and Diving	High Diving
Azuma, Miyoko		F	162.0	60.0	'45 • 3 • 10	Natation et plongeurs	100m, 4X100m Free

NAME NOM	NO. NO.	SEX SEXE	HEIGHT HAUTEUR	WEIGHT POIDS	DATE OF BIRTH DATE DE NAISSANCE	EVENT EPREUVE
Ezaka, Kimiko		F	164.0	60.0	'43 • 11 • 6	Swimming and Diving Natation et Plongeurs
Fujimoto, Tatsuo		M	176.0	67.0	'40 • 3 • 29	400m Ind. Medley
Fujishima, Shozo		M	170.0	58.0	'44 • 11 • 8	100m, 4X100m Free
Fukui, Makoto		M	170.0	71.0	'40 • 2 • 28	4X200m Free
Fukushima, Shigeo		M	181.0	75.0	'43 • 1 • 2	4X100m, 4X200m Free
Goto, Tadaharu		M	182.0	72.0	'41 • 12 • 4	200m Back
Hayakawa, Kazue		F	161.0	53.0	'47 • 6 • 13	100m, 4X100m Free
Ishihara, Katsuki		M	167.0	70.0	'39 • 3 • 10	400m Free
Ishikawa, Kenji		M	172.0	70.0	'46 • 1 • 10	4X200m Free
Ito, Keisuke		M	170.0	70.0	'43 • 10 • 29	4X100m Medley
Iwamoto, Kazuyuki		M	166.0	55.0	'46 • 11 • 15	200m Back
Iwasaki, Kunihiro		M	175.0	77.0	'44 • 10 • 5	200m Back
Kadonaga, Yoshinori		M	165.0	65.0	'47 • 1 • 7	1500m Free
Kaneto, Shunsuke		M	155.0	50.0	'40 • 1 • 5	4X200m Free
Kawai, Hatsuko		F	157.0	52.0	'37 • 2 • 9	200m Butterfly
Kihara, Michiko		F	167.0	59.0	'48 • 4 • 5	Springboard, High Diving
Kikutani, Tazuko		F	158.0	56.0	'47 • 2 • 24	High Diving
Kimura, Toyoko		F	166.0	66.0	'46 • 3 • 29	100m Back, 4X100m Free, 4X100m Medley
Mabuchi, Kanoko		F	160.0	50.0	'38 • 1 • 6	400m, 4X100m Free, 4X100m Medley
Matsuda, Natsuko		F	161.0	61.0	'47 • 6 • 19	Springboard Diving
Matsumoto, Kenjiro		M	171.0	73.0	'43 • 9 • 23	400m Ind. Medley
Morizane, Yeshiko		F	150.0	48.0	'48 • 9 • 4	200m Breast
Nakajima, Isao		M	172.0	70.0	'41 • 2 • 1	200m Breast
Nakano, Satoru		M	177.0	79.0	'47 • 1 • 9	4X100m Medley
Ohbayashi, Atsushi		M	175.0	74.0	'43 • 2 • 24	1500m Free
Okabe, Yukiaki		M	167.0	65.0	'41 • 4 • 24	200m Butterfly
Osaki, Keiko		F	155.0	52.0	'42 • 10 • 15	100m, 4X100m Free
Osumi, Isagi		M	174.0	68.0	'42 • 6 • 22	High Diving
Otsubo, Toshio		M	168.0	63.0	'43 • 2 • 26	200m Back
Saito, Hiroko		F	160.0	55.0	'45 • 1 • 18	High Diving
Sasaki, Sueaki		M	174.0	68.0	'42 • 11 • 16	100m Butterfly
Sato, Kimiko		F	161.0	55.0	'46 • 1 • 6	1500m Free
Sato, Kohsuke		M	161.0	63.0	'42 • 8 • 3	100m Butterfly
Shikiishi, Yoshiaki		M	176.0	65.0	'41 • 10 • 6	200m Butterfly
Shoji, Toshio		M	178.0	75.0	'40 • 8 • 25	200m Breast
Takahashi, Eiko		F	159.0	65.0	'45 • 9 • 21	4X200m Free
Tanaka, Satoko		F	158.0	59.0	'42 • 2 • 3	100m Butterfly, 4X100m Medley
Tosa, Tadao		M	165.0	62.0	'42 • 7 • 27	100m Back, 4X100m Medley
Tsurumine, Osamu		M	171.0	72.0	'41 • 8 • 21	Springboard Diving
Urakami, Ryoko		F	158.0	48.0	'47 • 5 • 30	200m Breast
Watanabe, Kumiko		F	168.0	61.0	'36 • 5 • 10	100m, 4X100m Free
Yamakage, Takeshi		M	172.0	70.0	'45 • 1 • 12	Springboard, High Diving
Yamamoto, Noriko		F	160.0	65.0	'44 • 9 • 26	400m Free
Yamanaka, Tsuyoshi		M	170.0	76.0	'39 • 1 • 18	200m Breast
Yamano, Toshio		M	173.0	65.0	'37 • 7 • 15	400m Free
Yoshimuta, Haruo		M	175.0	77.0	'39 • 11 • 5	Springboard Diving
Fukutome, Yoshihide	27	M	167.0	62.0	'33 • 3 • 10	Modern Pentathlon
Kawada, Urakichi	28	M	180.0	74.0	'39 • 5 • 18	Pentathlon Moderne
Mino, Shigeki	29	M	172.0	67.0	'32 • 2 • 5	"
Uchino, Shigeaki	30	M	170.0	68.0	'31 • 1 • 20	"
Chiba, Mikio		M	172.0	61.5	'35 • 5 • 1	Equestrian Sports
Hoketsu, Hiroshi		M	168.0	61.0	'41 • 3 • 28	Sport Equestre
Inoue, Kikuko		F	160.0	50.0	'24 • 12 • 3	Three-Day Event
Kageyama, Yuzo		M	170.0	55.0	'35 • 12 • 25	Jumping Grand Prix
Katsumoto, Masanori		M	163.0	50.0	'33 • 9 • 18	Dressage Grand Prix
Maeda, Rikutoshi		M	164.0	57.0	'31 • 2 • 17	Jumping Grand Prix
Matsudaira, Masaki		M	172.0	65.0	'43 • 1 • 10	Three-Day Event
Matsudaira, Yoritsune		M	175.0	55.0	'40 • 12 • 23	Three-Day Event
Okabe, Nagahira		M	156.0	65.0	'13 • 8 • 10	Dressage Grand Prix

NAME NOM	NO. NO.	SEX SEXE	HEIGHT HAUTEUR	WEIGHT POIDS	DATE OF BIRTH DATE DE NAISSANCE	EVENT EPREUVE	
Sasa, Shinzo		M	165.0	62.0	'35 • 12 • 15	Equestrian Sports	Jumping Grand Prix
Sato, Denichi		M	157.0	50.0	'36 • 10 • 28	Sport Equestre	Jumping, Dressage, Grand Prix,
Ishige, Toshiyasu	52	M	172.0	80.0	'32 • 1 • 16	Shooting	Three-Day Event
Ishii, Takao	187	M	169.3	66.0	'41 • 2 • 1	Tir	Clay Pigeon
Kubo, Kanji	192	M	166.0	75.0	'38 • 6 • 7	"	Small Bore-3 P., Prone
Ochiai, Osamu	191	M	167.5	55.0	'31 • 9 • 8	"	Rapid Fire Pistol
Rinzaki, Akihiro	188	M	169.5	53.5	'42 • 5 • 27	"	Rapid Fire Pistol
Saito, Shigemi	185	M	164.0	55.0	'37 • 2 • 25	"	Small Bore-Prone
Sanami, Mitsuo	53	M	175.0	65.0	'37 • 3 • 7	"	Free Rifle, Small Bore-3 P.
Takahashi, Shinji	189	M	177.0	70.0	'37 • 10 • 12	"	Clay Pigeon
Watanuki, Hajime	186	M	166.5	56.0	'39 • 4 • 30	"	Free Pistol
Yoshikawa, Yoshihisa	190	M	165.0	62.0	'36 • 9 • 4	"	Free Rifle
Demachi, Yutaka	1	M	175.0	72.0	'35 • 2 • 17	Volley-Ball	Free Pistol
Fujimoto, Yuko	12	F	155.0	56.0	'43 • 1 • 14	"	
Handa, Yuriko	4	F	166.0	60.0	'40 • 3 • 31	"	
Higuchi, Tokihiko	7	M	189.0	78.0	'41 • 6 • 10	"	
Ikedo, Naohiro	4	M	186.0	78.0	'40 • 1 • 17	"	
Isobe, Sata	6	F	173.0	60.0	'44 • 12 • 19	"	
Kasai, Masae	1	F	174.0	63.0	'33 • 7 • 14	"	
Kondo, Masako	7	F	168.0	63.0	'41 • 3 • 27	"	
Kosedo, Toshiaki	6	M	187.0	76.0	'41 • 5 • 20	"	
Koyama, Tsutomu	2	M	181.0	73.0	'36 • 7 • 26	"	
Matsumura, Katsumi	9	F	172.0	72.0	'44 • 3 • 8	"	
Matsumura, Yoshiko	5	F	170.0	65.0	'41 • 12 • 9	"	
Minami, Masayuki	8	M	196.0	81.0	'41 • 7 • 8	"	
Miyamoto, Emiko	2	F	172.0	56.0	'37 • 5 • 10	"	
Moriyama, Teruhisa	10	M	187.0	82.0	'42 • 3 • 17	"	
Nakamura, Yuzo	11	M	183.0	83.0	'42 • 4 • 24	"	
Nekota, Katsutoshi	12	M	178.0	70.0	'44 • 2 • 1	"	
Sasaki, Setsuko	11	F	173.0	60.0	'44 • 10 • 16	"	
Sato, Yasutaka	5	M	184.0	78.0	'40 • 2 • 3	"	
Shibuki, Ayano	8	F	165.0	61.0	'41 • 3 • 29	"	
Shinozaki, Yoko	10	F	171.0	65.0	'45 • 1 • 29	"	
Sugahara, Sadatoshi	3	M	177.0	73.0	'39 • 2 • 18	"	
Tanida, Kinuko	3	F	167.0	65.0	'39 • 9 • 18	"	
Tokutomi, Takeshi	9	M	180.0	74.0	'41 • 11 • 13	"	
Aoyama, Reizo		M	174.0	69.0	'39 • 9 • 27	Water Polo	
Arakawa, Hachiro		M	172.0	64.0	'33 • 8 • 8	"	
Fujimoto, Shigenobu		M	176.0	70.0	'39 • 9 • 3	"	
Iida, Norihide		M	170.0	69.0	'38 • 10 • 26	"	
Kato, Mineo		M	173.0	71.0	'34 • 3 • 27	"	
Kuwabara, Shigeharu		M	176.0	74.0	'40 • 12 • 3	"	
Satsuki, Keisuke		M	173.0	72.0	'41 • 5 • 6	"	
Shimizu, Yoji		M	173.0	70.0	'41 • 1 • 26	"	
Takagi, Koki		M	172.0	72.0	'36 • 12 • 22	"	
Takeuchi, Kazuya		M	174.0	72.0	'41 • 8 • 29	"	
Yokoyama, Takashi		M	174.0	72.0	'40 • 9 • 30	"	
Funaoka, Tadashi		M	165.0	51.0	'32 • 11 • 15	Yachting	Dragon
Hagiwara, Takeshi		M	171.0	65.0	'37 • 1 • 9	"	5.5m
Hori, Teruyuki		M	168.0	62.0	'33 • 1 • 15	"	Dragon
Ishii, Masayuki		M	165.0	53.0	'31 • 4 • 18	"	Star
Kojima, Masayoshi		M	174.0	73.0	'38 • 12 • 14	"	Reserve
Matsuda, Kenjiro		M	170.0	66.0	'35 • 6 • 23	"	F. Dutchman
Matsumoto, Fujiya		M	170.0	64.0	'32 • 3 • 25	"	5.5m
Okubo, Takafumi		M	180.0	75.0	'42 • 1 • 1	"	Star
Tagami, Yasutoshi		M	167.0	56.0	'34 • 2 • 15	"	F. Dutchman
Tanamachi, Saburo		M	157.0	50.0	'31 • 7 • 12	"	Dragon
Yamada, Takashi		M	169.0	75.0	'38 • 10 • 2	"	Finn
Yoshida, Masao		M	169.0	64.0	'32 • 11 • 30	"	5.5m

NAME NOM	NO. NO.	SEX SEXE	HEIGHT HAUTEUR	WEIGHT POIDS	DATE OF BIRTH DATE DE NAISSANCE	EVENT EPREUVE
KENYA KENYA						
Antao, Serafino	384	M	185.0	66.0	'37 • 10 • 30	Athletics Athlétisme 100m, 200m
Francis, Peter	387	M	170.0	88.0	'36 • 12 • 22	" 800m
Keino, Kipchoge	388	M	170.0	71.0	'40 •	" 1500m, 5000m
Kiprop, Koech	393	M	180.0	87.0	'34 •	" Decathlon
Kiprugut, Wilson	386	M	172.0	76.0	'38 •	" 400m, 800m
Kogo, Benjamin	392	M	165.0	75.0	'46 •	" 3000m S. C.
Nyakwayo, Chrisantus	389	M	170.0	70.0	'44 •	" Marathon
Owiti, John	383	M	185.0	90.0	'42 •	" 100m
Soi, Andrew	391	M	170.0	65.0	'38 •	" 10000m, Marathon
Songok, Kimaru	385	M	170.0	70.0	'36 •	" 400m Hurdles
Temu, Naftali	390	M	168.0	67.0	'45 •	" 10000m, Marathon
Gakungu, Gichure	160	M	183.0	67.0	'24 • 1 • 1	Boxing Boxe Welter
Kamau, John	156	M	168.0	51.0	'47 •	" Fly
Olulu, John	159	M	173.0	63.5	'44 •	" L. Welter
Oundo, Alex	158	M	173.0	60.0	'43 • 12 •	" Light
Waruinge, Philip	157	M	170.0	54.0	'45 • 2 • 3	" Bantam
Aggarwal, Krishan Kumar	14	M	177.5	62.0	'39 • 1 • 25	Hockey
Bhardwaj, Kirpal Singh	13	M	167.5	62.0	'35 • 9 • 9	"
Brar, Tejparkash Singh	18	M	167.5	63.0	'37 • 10 • 25	"
D Souza, Reynold Anthony	10	M	167.5	65.5	'37 • 9 • 8	"
Fernandes, Edgar Simon C.	8	M	172.5	70.5	'38 • 4 • 12	"
Fernandes, Egbert Carmo	9	M	175.0	66.0	'41 • 6 • 25	"
Fernandes, Hilary John	7	M	171.0	62.0	'37 • 10 • 22	"
Fernandes, Leo C. D.	16	M	172.0	72.3	'42 • 6 • 18	"
Fernandes, Silvester	6	M	170.0	66.0	'36 • 11 • 26	"
George, Saude Andre	1	M	.	.	'32 • 11 • 30	"
Khan, Abdul Samad	17	M	165.0	57.0	'42 • 3 • 11	"
Mangat, Amar Singh	15	M	180.0	71.0	'35 • 5 • 26	"
Matharu, Santokh Singh	4	M	177.5	64.0	'42 • 3 •	"
Mendonca, Aloysius Edward	11	M	175.0	.	'33 • 1 • 5	"
Panesar, Surjeet Singh	5	M	170.0	67.0	'40 • 1 • 6	"
Simonian, John Levon	12	M	178.0	63.0	'35 • 12 • 15	"
Sohal, Avtar Singh	3	M	180.0	75.0	'38 • 3 • 22	"
Vaz, Anthony Querobino E.	2	M	.	.	'32 • 9 • 14	"
Bull, Leonard James	197	M	177.0	90.0	'35 • 1 • 25	Shooting Tir Rapid Fire Pistol
Handford-Rice, Alan	196	M	184.0	80.0	'25 • 9 • 19	" Rapid Fire Pistol
Horner, Michael G. D.	195	M	.	.	'38 • 3 • 27	" Free Pistol
Vernon-Roberts, Neil	194	M	.	.	'33 • 9 • 20	" Small Bore-Prone
Cooke, Peter		M	172.0	69.0	'24 • 9 • 23	Yachting Finn
Elkington, Frank George		M	172.0	77.0	'30 • 2 • 8	" Reserve
KOREA COREE						
Chang, Jong Kil	395	M	.	.	'39 • 6 • 3	Athletics Athlétisme 400m
Chung, Ki Sun	394	M	168.0	63.0	'37 • 4 • 25	" 100m, 200m
Chung, Kyo Mo	396	M	171.0	64.0	'40 • 7 • 25	" 800m, 1500m
Han, Jook Hee	130	F	160.0	51.0	'41 • 5 • 8	" Long Jump
Han, Myung Hee	127	F	165.0	55.0	'45 • 11 • 20	" 400m, 800m, 4X100m
Hwang, Chung Dae	397	M	165.0	61.0	'40 • 9 • 14	" Triple Jump
Joo, Hyung Kail	403	M	163.0	53.0	'39 • 8 • 20	" Marathon
Kim, Byung Ki	399	M	170.0	80.0	'38 • 2 • 13	" Discus Throw
Kim, Yun Bum	402	M	170.0	58.0	'34 • 12 • 10	" Marathon
Lee, Hak Ja	128	F	165.0	58.0	'41 • 4 • 2	" 4X100m, Pentathlon
Lee, He Ja	132	F	164.0	64.5	'47 • 2 • 14	" Javelin Throw
Lee, Sang Hoon	404	M	169.0	55.0	'38 • 9 • 30	" Marathon
Park, Hi Sook	129	F	164.0	53.0	'45 • 12 • 14	" 4X100m
Park, Soo Kwon	400	M	173.0	75.0	'41 • 1 • 28	" Javelin Throw
Park, Young Sook	131	F	167.0	62.0	'47 • 1 • 24	" Discus Throw
Rim, Dong Sil	401	M	180.0	82.0	'37 • 1 • 5	" Hammer Throw
Rim, He Kun	396	M	181.0	90.0	'39 • 11 • 1	" Shot Put

NAME NOM	NO. NO.	SEX SEXE	HEIGHT HAUTEUR	WEIGHT POIDS	DATE OF BIRTH DATE DE NAISSANCE	EVENT EPREUVE	
Song, Yang Ja	126	F	161.0	55.0	'44 • 6 • 19	Athletics Athlétisme	100m, 200m, 4X100m
Ahn, Jong Duck		M	182.5	79.0	'42 • 6 • 14	Rowing Aviron	Eight, With Cox
Choi, Shin Il		M	186.0	86.0	'42 • 4 • 1	"	Eight, With Cox
Chun, Sung Tae		M	180.5	75.0	'43 • 5 • 20	"	Eight, With Cox
Han, Young Joon		M	185.5	78.0	'37 • 7 • 11	"	Reserve, Oarsmen
Ji, Duk Han		M	179.0	76.0	'40 • 7 • 15	"	Eight, With Cox
Kim, Heun Chong		M	182.0	78.0	'42 • 2 • 25	"	Eight, With Cox
Kim, Kyu San		M	184.0	84.0	'41 • 9 • 1	"	Eight, With Cox
Lee, Eun San		M	158.5	49.5	'40 • 11 • 25	"	Reserve, Oarsmen
Lee, Sang Woo		M	174.0	73.0	'43 • 4 • 1	"	Eight, With Cox
Park, Shin Young		M	157.0	48.5	'42 • 7 • 26	"	Eight, With Cox
Yoo, Hyeok Keun		M	176.0	75.0	'44 • 5 • 10	"	Eight, With Cox
Yun, Young Wung		M	174.0	76.0	'41 • 4 • 23	"	Eight, With Cox
Bang, Yeul	11	M	178.0	66.0	'41 • 10 • 10	Basket-Ball	
Chung, Jin Bong	15	M	185.0	80.0	'43 • 3 • 21	"	
Har, Ui Kon	4	M	188.0	80.0	'43 • 3 • 5	"	
Kim, Chung Sun	7	M	189.0	80.0	'39 • 7 • 30	"	
Kim, In Kun	12	M	180.0	70.0	'44 • 3 • 11	"	
Kim, Moon Hyun	9	M	179.0	71.0	'41 • 6 • 16	"	
Kim, Seung Kyu	14	M	193.0	80.0	'43 • 1 • 19	"	
Kim, Young Il	13	M	187.0	80.0	'42 • 2 • 25	"	
Kim, Young Ki	6	M	178.0	66.0	'36 • 1 • 7	"	
Lee, Byung Goo	5	M	175.0	66.0	'42 • 6 • 20	"	
Moon, Hyun Chang	8	M	182.0	70.0	'37 • 5 • 12	"	
Sin, Dong Pa	10	M	188.0	80.0	'44 • 9 • 2	"	
Choh, Dong Kih	161	M	161.0	51.0	'37 • 12 • 18	Boxing Boxe	Fly
Chung, Shin Cho	162	M	162.0	54.0	'40 • 1 • 6	"	Bantam
Kim, Duk Pal	168	M	177.0	77.0	'42 • 1 • 23	"	Middle
Lee, Hong Man	166	M	177.0	69.0	'41 • 1 • 25	"	Welter
Lee, Kum Taik	167	M	173.0	71.0	'42 • 1 • 13	"	L. Middle
Park, Koo Il	165	M	175.0	65.0	'44 • 3 • 15	"	L. Welter
Suh, Bun Nam	164	M	165.0	60.0	'39 • 12 • 5	"	Light
Suk, Jong Gu	163	M	169.0	57.0	'44 • 2 • 23	"	Feather
Ahn, Byung Hoon	81	M	170.0	60.0	'40 • 10 • 6	Cycling Cyclisme	Road Ind., Team T. T.
Cho, Sung Hwan	82	M	169.0	65.0	'43 • 2 • 7	"	Road Ind., Team T. T.
Hong, Sung Ik	83	M	170.0	65.0	'40 • 9 • 1	"	Road Ind., Team T. T.
Hwang, Chang Shik	85	M	174.5	65.0	'43 • 6 • 8	"	Reserve
Lee, Sun Bai	84	M	186.5	65.0	'39 • 6 • 2	"	Road Ind., Team T. T.
We, Kyung Yong	86	M	168.0	63.0	'40 • 3 • 23	"	Reserve
Hahn, Myung Seok	174	M	170.0	60.0	'44 • 7 • 15	Fencing Escrime	Foil, Epee Ind., Team
Kim, Chang Hwan	177	M	170.0	60.0	'16 • 9 • 24	"	Foil, Epee Ind., Team
Kim, Man Shik	176	M	153.0	55.0	'40 • 12 • 30	"	Foil, Epee Ind., Team
Shin, Doo Ho	175	M	176.0	64.0	'34 • 10 • 13	"	Foil Epee Team
Shin, Kwang Sook	173	F	160.0	56.0	'46 • 11 • 8	"	Foil Ind.
Cha, Kyung Bok	17	M	172.0	64.0	'38 • 1 • 10	Football	
Cha, Tae Sung	5	M	173.0	70.0	'34 • 10 • 8	"	
Cho, Sung Dal	11	M	172.0	64.0	'35 • 12 • 8	"	
Cho, Yoon Ok	10	M	166.0	67.0	'40 • 2 • 25	"	
Chung, Yong Hwan	19	M	171.0	69.0	'38 • 12 • 7	"	
Ham, Heung Chul	1	M	175.0	69.0	'30 • 11 • 17	"	
Huh, Yoon Jung	8	M	175.0	70.0	'36 • 9 • 30	"	
Kim, Chan Ki	15	M	167.0	60.0	'32 • 12 • 30	"	
Kim, Duk Joong	18	M	166.0	63.0	'40 • 4 • 29	"	
Kim, Hong Bok	3	M	178.0	67.0	'35 • 3 • 4	"	
Kim, Jung Nam	13	M	170.0	58.0	'43 • 1 • 28	Football	
Kim, Jung Suk	2	M	176.0	65.0	'39 • 10 • 1	"	
Kim, Kyu Hwan	21	M	170.0	72.0	'21 • 7 • 16	"	
Kim, Sam Rak	4	M	162.0	61.0	'40 • 6 • 19	"	
Kim, Young Bai	6	M	169.0	61.0	'41 • 1 • 10	"	

NAME NOM	NO. NO.	SEX SEXE	HEIGHT HAUTEUR	WEIGHT POIDS	DATE OF BIRTH DATE DE NAISSANCE	EVENT EPREUVE
Lee, Woo Bong	12	M	163.0	60.0	'35 • 6 • 8	Football
Lee, Yi Woo	7	M	175.0	69.0	'41 • 2 • 18	"
Park, Seung Ok	14	M	167.0	68.0	'38 • 1 • 28	"
Woo, Sang Kwon	9	M	159.0	58.0	'29 • 12 • 22	"
Yoo, Kwang Joon	16	M	160.0	61.0	'32 • 3 • 7	"
Choi, Young Sook	135	F	153.0	48.0	'47 • 5 • 14	Gymnastics
Chung, Bong Soon	134	F	160.0	49.5	'47 • 5 • 27	Gymnastique
Chung, Yi Kwang	14	M	162.0	58.0	'42 • 1 • 11	"
Hahn, Soo Hee	13	M	162.0	56.0	'40 • 7 • 28	"
Kang, Soo Il	17	M	158.5	52.0	'43 • 10 • 8	"
Kim, Choong Tai	16	M	169.0	67.0	'44 • 1 • 16	"
Kim, Kwang Duk	15	M	163.0	58.0	'42 • 1 • 1	"
Lee, Duk Boon	133	F	149.0	49.0	'45 • 12 • 12	"
Lee, Kwang Jae	12	M	159.0	54.0	'41 • 9 • 25	"
Suh, Jae Kyu	11	M	160.0	56.0	'40 • 8 • 27	"
Hur, Chang Bum	96	M	177.0	75.0	'40 • 12 • 17	Weight-Lifting Halterophilie
Hwang, Ho Dong	159	M	180.0	110.0	'36 • 12 • 25	"
Kim, Hae Nam	47	M	161.0	62.0	'29 • 5 • 23	"
Lee, Hyung Woo	120	M	170.0	84.0	'42 • 10 • 3	"
Lee, Jong Sup	97	M	172.0	78.0	'35 • 10 • 30	"
Yang, Mu Shin	22	M	162.0	56.0	'42 • 2 • 28	"
Yu, In Ho	23	M	159.0	58.0	'29 • 2 • 16	"
Kim, Eui Tae		M	174.0	78.0	'41 • 6 • 2	Judo
Kim, Jong Dal		M	173.0	85.0	'36 • 5 • 28	"
Park, Chung Sam		M	164.0	65.0	'46 • 11 • 9	"
Suh, Sang Chul		M	168.0	70.0	'41 • 5 • 8	"
Chang, Chang Sun		M	158.0	56.0	'42 • 6 • 12	Wrestling
Chang, Yi Hyun		M	160.0	60.0	'43 • 9 • 4	Lutte
Choi, Byung Sup		M	175.0	80.0	'38 • 2 • 25	"
Choi, Young Kil		M	164.0	62.0	'42 • 3 • 6	"
Chung, Dong Goo		M	173.0	73.0	'42 • 3 • 20	"
Kang, Doo Man		M	189.0	88.0	'33 • 4 • 12	"
Kim, Bong Jo		M	168.0	66.0	'42 • 5 • 29	"
Kim, Ik Jong		M	164.0	70.0	'41 • 5 • 10	"
Lee, Ki Yul		M	179.0	85.0	'40 • 2 • 29	"
Shin, Dong Eui		M	175.0	77.0	'41 • 5 • 28	"
Shin, Sang Shik		M	160.0	55.0	'41 • 10 • 12	"
Yoon, Dae Kih		M	168.0	65.0	'40 • 9 • 22	Swimming and Diving
Chin, Jang Rhim		M	179.0	82.0	'42 • 10 • 15	Natation et Plongeon
Cho, Chang Jae		M	168.0	64.0	'43 • 10 • 10	"
Chun, Ok Ja		F	157.0	46.0	'48 • 4 • 13	"
Chung, Hee Jung		F	155.0	49.0	'47 • 8 • 8	"
Kim, Bong Jo		M	173.0	70.0	'46 • 1 • 13	"
Lim, Kum Ja		F	161.0	56.0	'47 • 4 • 20	"
Song, Jae Ung		M	170.0	67.0	'45 • 4 • 2	"
Choi, Kui Seung	31	M	180.7	73.0	'41 • 5 • 13	Modern Pentathlon
Ahn, Duk Kee		M	173.0	58.0	'40 • 1 • 3	Pentathlon Moderne
Cho, Hyung Won		M	173.0	65.0	'36 • 7 • 12	Equestrian Sports
Kim, Chul Kyu		M	172.0	62.0	'38 • 8 • 20	Sport Equestre
Kim, Moon Shik		M	167.0	56.0	'28 • 12 • 1	"
Kim, Young Ro		M	167.0	61.0	'29 • 5 • 28	"
Lee, Il Kyu		M	168.0	58.0	'40 • 9 • 16	"
Suh, Myoung Won		M	167.0	56.0	'36 • 9 • 29	"
Ahn, Jai Song	202	M	167.0	67.0	'34 • 5 • 3	Shooting
Ahn, Jung Keun	33	M	174.0	72.0	'24 • 11 • 20	Tir
Choo, Wha Il	201	M	164.0	62.0	'32 • 4 • 30	"
Huh, Wook Bong	200	M	168.0	63.0	'34 • 3 • 1	"
Lee, Jong Hyun	205	M	178.0	65.0	'30 • 5 • 8	"
Nam, Sang Wan	199	M	164.0	63.0	'35 • 1 • 15	"

NAME NOM	NO. NO.	SEX SEXE	HEIGHT HAUTEUR	WEIGHT POIDS	DATE OF BIRTH DATE DE NAISSANCE	EVENT EPREUVE	
Bahk, Nahm Kyu	204	M	165.0	58.0	'36 • 10 • 9	Shooting Tir	Rapid Fire Pistol
Park, Sam Kyu	34	M	175.0	75.0	'32 • 2 • 6	"	Clay Pigeon
Shin, HyunJoo	198	M	170.5	65.0	'34 • 8 • 2	"	Free Rifle, Small Bore-3 P.
Suh, Kang Wook	203	M	164.0	57.0	'29 • 3 • 26	"	Free Pistol
Chung, Sun Hung	4	M	179.0	75.0	'38 • 10 • 12	Volley-Ball	
Kim, In Soo	1	M	175.0	70.0	'30 • 8 • 18	"	
Kim, Jin Hee	11	M	178.0	71.0	'40 • 3 • 1	"	
Kim, Kwang Soo	10	M	178.5	72.0	'39 • 11 • 4	"	
Kim, Sung Kil	9	M	185.0	70.0	'42 • 1 • 14	"	
Kim, Young Joon	8	M	180.0	78.0	'40 • 8 • 31	"	
Lee, Kyu Soh	7	M	170.0	63.0	'41 • 7 • 7	"	
Lim, Tae Hoh	12	M	175.0	65.0	'40 • 12 • 12	"	
Oh, Pyong Kil	2	M	181.0	72.0	'44 • 4 • 15	"	
Park, Suh Kwang	5	M	183.0	75.0	'42 • 1 • 16	"	
Sohn, Young Wan	3	M	191.0	74.0	'34 • 3 • 4	"	
Suh, San Suk	6	M	186.0	80.0	'40 • 5 • 2	"	
Suh, Choon Kang	1	F	168.0	61.0	'44 • 2 • 21	"	
Moon, Kyung Sook	2	F	169.0	60.0	'45 • 2 • 5	"	
Ryoo, Choon Ja	3	F	161.0	53.0	'45 • 6 • 3	"	
Oh, Soon Ok	5	F	169.0	64.0	'45 • 11 • 16	"	
Kim, Kil Ja	4	F	174.0	67.0	'43 • 9 • 23	"	
Chung, Jong Uen	6	F	168.0	60.0	'45 • 7 • 18	"	
Choi, Don Hi	7	F	165.0	59.0	'45 • 12 • 10	"	
Hong, Nam Sun	8	F	168.0	60.0	'45 • 2 • 11	"	
Oh, Chung Ja	9	F	164.0	58.0	'44 • 9 • 14	"	
Yoon, Jung Sook	10	F	167.0	58.0	'48 • 1 • 2	"	
Kwak, Ryong Ja	11	F	167.0	60.0	'47 • 9 • 24	"	
Lee, Keun Soo	12	F	167.0	53.0	'46 • 7 • 9	"	
LEBANON LIBAN							
Gemayel, Joseph	180	M	181.0	68.0	'44 •	Fencing Escrime	Epee Ind., Team
Osman, Ibrahim	178	M	178.0	79.0	'27 •	"	Epee Ind., Team
Saikali, Michel	181	M	178.0	75.0	'32 •	"	Epee Ind., Team
Sayd, Hassan	179	M	172.0	72.0	'24 •	"	Epee Ind., Team
Aoun, Joseph	39	M	164.0	69.5	'33 • 11 • 18	Shooting Tir	Clay Pigeon
Saad, Antonios	40	M	164.5	67.0	'34 • 3 • 25	"	Clay Pigeon
LIBELIA LIBERIA							
Johnson, Wesley	405	M	168.0	58.0	'44 • 5 • 27	Athletics Athlétisme	100m, 200m, 400m
LIBYA LIBYE							
Fighi Hassan, Suliman	411	M	178.0	70.0	'34 • 10 • 24	Athletics Athlétisme	Marathon
LIECHTENSTEIN LIECHTENSTEIN							
Buchel, Alois	407	M	176.0	77.0	'41 • 4 • 16	Athletics Athlétisme	Decathlon
Walsler, Hugo	406	M	185.0	67.0	'40 • 6 • 1	"	800m, 1500m
LUXEMBOURG LUXEMBOURG							
Aniset, Jean	409	M	167.0	60.0	'34 • 9 • 15	Athletics Athlétisme	Marathon
Medinger, Michel	408	M	195.0	77.5	'41 • 4 • 18	"	800m, 1500m
Sowa, Charles	410	M	168.0	64.0	'33 • 4 • 15	"	20km, 50km Road Walk
Schleck, Johnny	88	M	185.5	72.0	'42 • 11 • 22	Cycling Cyclisme	Ind. Road
Schutz, Edy	87	M	176.0	72.0	'41 • 5 • 15	"	Ind. Road
Flesch, Colette	182	F	163.5	62.5	'37 • 4 • 16	Fencing Escrime	Foil Ind.
Rossini, Ginette	183	F	162.0	54.0	'39 • 10 • 26	"	Foil Ind.
Stefanetti, Ady	144	M	159.0	60.0	'42 • 11 • 17	Gymnastics Gymnastique	
Stoffel, Josy	145	M	165.5	68.0	'28 • 6 • 27	"	
Schummer, Raymond		M	178.5	87.0	'37 • 3 • 31	Wrestling Lutte	Greco R.-Middle
Welbes, Georges		M	182.0	63.0	'44 • 6 • 11	Swimming and Diving Natation et Plongeon	100m Free
Kremer, Victor	206	M	170.5	67.0	'32 • 7 • 31	Shooting Tir	Small Bore-3 P., Prone
MADAGASCAR MADAGASCAR							
Rabemila, Marc	414	M	166.0	56.0	'38 • 4 • 27	Athletics Athlétisme	Triple Jump
Randrianjatovo, Jean	413	M	159.0	54.0	'36 • 11 • 25	"	1500m, 5000m, Marathon
Ravelomanantsoa, J.	412	M	169.0	66.0	'43 • 4 • 30	"	100m, 200m

NAME NOM	NO. NO.	SEX SEXE	HEIGHT HAUTEUR	WEIGHT POIDS	DATE OF BIRTH DATE DE NAISSANCE	EVENT EPREUVE
MALAYSIA MALAISIE						
Victor, A.	423	M	.	.		Athletics Athlétisme 4X400m
Kunalan, C.	422	M	.	.		" 4X100m
Dilbagh, Singh Kler	419	M	165.0	63.5	'40 •	" 3000m S. C.
Dukom, John	420	M	.	.		" 4X100m
Jegathesan, M.	415	M	171.0	59.0	'44 •	" 100m, 200m, 400m 4X100m 4X400m
Selvaratnam, K.	418	M			'40 •	" 4X400m, 400m Hurdles
Kuda, Ditta	417	M	183.0	72.5	'43 •	" 4X100m, 4X400m, 110m Hurdles
Rajamani, M.	133	F	70.0	.	'45 •	" 400m, 800 m
Hamzah, Mazlan	421	M	.	.		" 4X100m
Rahman, Mohd Abdul	424	M	.	.		" 4X400m
Nashathar, Singh Sidhu	425	M	.	68.5	'40 •	" Javelin Throw
Subramaniam, R.	416	M	183.0	59.0	'40 •	" 800m, 1500m, 4X400m
Gopalan, Ramakrishnan G.	170	M	178.0	63.5	'40 • 11 • 17	Boxing Boxe L. Welter
Ibrahim, Jumaat	169	M	165.0	50.0	'38 • 10 • 28	" Fly
Andrew, Michael	109	M	.	.	'43 • 9 • 27	Cycling Cyclisme Scratch Sprint, Ind. Road
Choy, Mow Thim	106	M	162.5	54.4	'47 • 5 • 29	" Team Pursuit, Road Team T. T
Hamid, Supaat	110	M	166.0	57.0	'44 • 11 • 11	" Scratch Sprint, Ind. Road
Kamsari, Salam	108	M	157.4	56.8	'41 • 1 • 10	" Team Pursuit
Ng, Joo Pong	105	M	.	61.0	'46 • 6 • 19	" 1000m T. T., Team Pursuit, Road Team, T. T.
Rosli, N. A.	107	M	167.6	59.0	'40 • 10 • 26	" Team Pursuit, Road Team T. T
Safarrudin, Zain	92	M	166.0	66.0	'38 • 3 • 22	" Ind. Road
Stephen, Lim Tian San	89	M	172.7	63.5	'42 • 10 • 18	" Ind. Road
Tjow, Choon Boon	111	M	165.0	49.8	'45 • 6 • 3	" Ind. Pursuit, Road Team T. T
Theseira, Ronnie Ignatius	184	M	.	.	'30 • 5 • 17	Fencing Escrime Foil, Epee, Sabre Ind.
Boo, Kim Siang	57	M	168.0	65.0	'38 • 1 • 21	Weight-Lifting Haltérophilie Light
Chua, Phung Kim	9	M	160.0	54.0	'39 • 4 • 29	" Bantam
Chung, Kum Weng	36	M	162.0	59.5	'34 • 5 • 15	" Feather
Leong, Chim Seong	128	M	172.0	88.0	'40 • 11 • 1	" M. Heavy
Lim, Hiang Kok	104	M	160.0	80.0	'29 • 9 • 9	" L. Heavy
Tan, Howe Liang	84	M	158.0	74.0	'33 • 5 • 5	" Middle
Arumugam, Sabapathy	12	M	.	.	'35 • 12 • 21	Hockey
Chanda Singh, Kartar S.	13	M	.	.	'36 • 12 • 18	"
Chelliah, Paramalingam	8	M	.	.	'36 • 11 • 15	"
Gurdit Singh, Ranjit S.	14	M	.	.	'38 • 3 • 24	"
Ho, Kuh Chye	1	M	.	.	'42 • 11 • 5	"
Kandiah, Anandarajah	2	M	.	.	'38 • 12 • 4	"
Koh, Hock Seng	10	M	.	.	'45 • 6 • 20	"
Kunaratnam, Alagaratnam	15	M	.	.	'43 • 10 • 29	"
Lim, Fung Chong	16	M	.	.		"
Manickam, Shanmuganathan	3	M	.	.		"
Manir Uddin, Anwarul H.	17	M	.	.	'39 • 12 • 3	"
Micheal, Arulraj	4	M	.	.	'38 • 5 • 22	"
Munusamy, Doraisamy	5	M	.	.	'37 • 10 • 2	"
Nonis, Douglas Paul	7	M	.	.	'37 • 1 • 25	"
Rajaratnam, Yogeswaran	11	M	.	.	'40 • 2 • 28	"
Sinnathamby, Kanagalingam	18	M	.	.	'41 • 4 • 22	"
Tara Singh Sindhu, S. S. S.	9	M	.	.	'43 • 7 • 19	"
Van Huizen, Lawrence J.	6	M	.	.	'30 • 7 • 30	"
Ang, Teck Bee		M	177.0	80.0	'21 • 12 • 10	Judo Heavy Weight
Moorthy, Kanapathy Sathia		M	177.0	75.0	'32 • 12 • 23	" Middle Weight
Liang, Soon Hin		M	165.1	49.1	'44 • 2 • 13	Wrestling Lutte Free S-Fly
Tham, Kook Chin		M	167.6	66.0	'43 • 11 • 7	" Free S-Light
Chan, Bernard Cheng Wah		M	177.5	71.8	'46 • 10 • 8	Swimming and Diving Natation et Plongéons 200m Butterfly, 4 x 100m Medley
Cheah, Tong Kim		M	163.0	63.5	'45 • 7 • 29	" 200m Breast, 4X100m Medley
Eu, Michael Seong Chin		M	177.5	62.8	'46 • 10 • 26	" 200m Back, 4X100m Medley
Jolly, Mariana		F	166.2	62.8	'48 • 2 • 4	" 200m Breast
Tan, Thuan Heng		M	165.0	62.8	'48 • 7 • 14	" 100m, 400m, 1500m Free, 4X100m Medley
Tay, Molly Chin Say		F	145.0	40.6	'52 • 8 • 13	" 100m Butterfly

NAME NOM	NO. NO.	SEX SEXE	HEIGHT HAUTEUR	WEIGHT POIDS	DATE OF BIRTH DATE DE NAISSANCE	EVENT EPREUVE	
Tseng, Jovina		F	157.5	52.5	'50 • 5 • 6	Swimming and Diving Natation et Plongeoons	100m, 400m Free, 100m Back
Filmer, Dennis	208	M	162.0	67.0	'16 • 6 • 26	Shooting	Small Bore-Prone
Goh, Tai Yong	44	M	165.0	75.0	'39 • 12 • 24	Tir	Clay Pigeon
Kok, Kum Woh	210	M	180.0	100.0	'15 • 5 • 18	"	Free Pistol
Loh, Ah Chee	211	M	177.0	86.0	'22 • 4 • 1	"	Rapid Fire Pistol
Tang, Peng Choy	209	M	167.0	68.0	'24 • 6 • 14	"	Small Bore-Prone
Wong, Foo Wah	207	M	171.0	83.0	'27 • 9 • 15	"	Small Bore-3 P.
Yap, Pow Thong	45	M	162.0	98.0	'18 • 11 • 8	"	Clay Pigeon
MALI MALI							
Camara, Sara	431	M	179.0	70.0	'40 • 8 • 16	Athletics Athlétisme	100m
Sereme, Dramane	432	M	181.0	80.0	'42 • 5 • 23	"	Decathlon
MEXICO MEXIQUE							
Giron Olivares, E. E.	134	F	161.0	50.5	'47 • 12 • 28	Athletics Athlétisme	100m, 200m
Lorenzo Manueco, Carlos	426	M	181.0	63.0	'42 • 2 • 25	"	100m, 200m
Mejia, Didier	427	M	172.0	65.0	'41 • 7 • 20	"	400m
Negrete Gamboa, Fidel	428	M	167.0	58.0	'32 • 3 • 23	"	Marathon
Peralta Jimenez, Victor	429	M	140.0	52.0	'42 • 9 • 16	"	Marathon
Friedrich, Roberto		M	184.0	74.0	'45 • 3 • 9	Rowing Aviron	Double Sculls
Plettner, Otto		M	190.0	82.0	'40 • 9 • 26	"	Single Sculls
Scheffler, Fernando		M	182.0	68.0	'45 • 5 • 30	"	Double Sculls
Stock, Paul		M	178.0	76.0	'29 • 3 • 2	"	Reserve, Oarsmen
Almanza Gonzalez, Alberto	13	M	204.0	88.0	'36 • 5 • 1	Basket-Ball	
Arellano Moreno, Miguel	7	M	188.0	82.0	'41 • 3 • 2	"	
Avila Saenz, Eulalio	9	M	195.0	80.0	'36 • 10 • 13	"	
Grajeda Alvarado, Luis E.	10	M	179.0	70.0	'37 • 6 • 21	"	
Heredia Estrella, Rafael	4	M	192.0	74.0	'37 • 2 • 19	"	
Herrera Montoya, Armando	6	M	174.0	72.0	'32 • 1 • 6	"	
Pena Maldonado, Mario	11	M	186.0	85.0	'40 • 9 • 7	"	
Pontvianne Jimenez, R. A.	14	M	189.0	73.0	'43 • 10 • 20	"	
Quintanar Rohana, Carlos	12	M	191.0	80.0	'37 • 11 • 22	"	
Raga Navarro, Manuel	15	M	187.0	71.0	'44 • 3 • 15	"	
Duran Aguirre, Jose A.	172	M	166.0	57.0	'44 • 1 • 17	Boxing Boxe	Feather
Fabila Mendoza, Juan	171	M	163.0	54.0	'44 • 6 • 5	"	Bantam
Ramirez Gutierrez, A.	175	M	180.0	67.0	'43 • 7 • 31	"	Welter
Serrano Escobar, Mariano	173	M	164.0	60.0	'41 • 2 • 19	"	Light
Zazueta Ruiz, Eduardo	174	M	176.0	63.5	'44 • 3 • 18	"	L. Welter
Belmonte Heredia, Adolfo	84	M	181.0	68.0	'44 • 1 • 10	Cycling Cyclisme	Road Team T. T.
Coronel Romero, Francisco	95	M	169.0	61.0	'42 • 8 • 7	"	Ind. Road
Diaz Ornelas, Heriberto	94	M	160.0	63.0	'41 • 1 • 5	"	Ind. Road
Duque Garza, Antonio	114	M	175.0	72.0	'39 • 11 • 13	"	Road Ind., Team T. T.
Lopez Morales, Moises	93	M	179.0	71.0	'40 • 6 • 29	"	Road Ind., Team T. T.
Mercado Escareno, Jose	112	M	174.0	73.0	'38 • 5 • 29	"	1000m T. T., Scratch, Tandem Sprint
Remigio Rivera, Porfirio	87	M	170.0	72.0	'39 • 9 • 15	"	Road Team T. T.
Soto Soto, Melesio	96	M	167.0	64.0	'41 • 11 • 29	"	Ind. Road
Tellez Gonzalez, Jose L.	113	M	171.0	70.0	'38 • 4 • 27	"	Scratch, Tandem Sprint
Albert Llorente, Carlos	3	M	185.0	75.0	'43 • 7 • 10	Football	
Arellano Gallo, Raul	13	M	174.0	65.0	'39 • 1 • 17	"	
Aussin Suarez, Jose Luis	15	M	174.0	63.0	'42 • 1 • 20	"	
Ayala, Mario	17	M	179.0	75.0	'42 • 8 • 10	"	
Calderon Gonzalez, I. F.	1	M	178.0	74.0	'43 • 12 • 13	"	
Chavez De La Rosa, Raul	10	M	174.0	65.0	'39 • 3 • 4	"	
Cisneros Salcedo, Ernesto	9	M	180.0	75.0	'40 • 10 • 26	"	
Escalante Vazquez, R.	16	M	176.0	63.0	'40 • 6 • 4	"	
Fragoso Rodriguez, Javier	8	M	178.0	71.0	'42 • 4 • 19	"	
Galvan Mena, Miguel	5	M	170.0	66.0	'37 • 6 • 23	"	
Gonzalez Davila, Jose L.	6	M	170.0	64.0	'42 • 9 • 14	"	
Gutierrez Padilla, Carlos	2	M	179.0	72.0	'39 • 3 • 31	"	
Hernandez Sanchez, G.	4	M	175.0	70.0	'42 • 6 • 25	"	
Lopez Sanchez, Pablo	14	M	164.0	66.0	'39 • 12 • 4	"	

NAME NOM	NO. NO.	SEX SEXE	HEIGHT HAUTEUR	WEIGHT POIDS	DATE OF BIRTH DATE DE NAISSANCE	EVENT EPREUVE
Loza Barba, Efrain	12	M	176.0	70.0	'39 • 1 • 10	Football
Mollinedo Holguin, A.	11	M	182.0	74.0	'42 • 1 • 7	"
Morales Perez, Albino	18	M	168.0	61.0	'42 • 5 • 30	"
Ruvalcaba Cisneros, F.	7	M	180.0	68.0	'41 • 2 • 16	"
Alanis, Mauro	37	M	163.0	61.0	'34 • 1 • 15	Weight-Lifting Haltérophilie
Arredondo Cepeda F., Rene		M	165.0	66.0	'44 • 8 • 18	Judo
Goldschmied Rodriguez, G.		M	181.0	79.5	'39 • 4 • 22	"
Goldschmied Rodriguez, S.		M	180.0	84.0	'40 • 10 • 19	"
Del Rio Gil, Cesar		M	165.0	52.0	'41 • 8 • 12	Wrestling
Echaniz Partida, A.		M	170.0	70.0	'42 • 9 • 7	Lutte
Lopez Ruiz, Moises		M	167.0	57.0	'41 • 9 • 3	"
Tovar Gonzalez, Mario		M	169.0	63.0	'33 • 8 • 15	"
Alanis Guerrero, Juan		M	175.0	65.0	'46 • 2 • 20	Swimming and Diving Natation et Plongeoins
Altamirano Tames, Gabriel		M	170.0	64.0	'46 • 5 • 24	"
Belmar Bohigas, Silvia		F	158.0	49.0	'45 • 8 • 2	"
Belmar, Olga		F	152.0	50.0	'46 • 9 • 22	"
Davila, Guillermo		M	165.0	50.0	'49 • 4 • 2	"
Echevarria Perez, G.		M	176.0	67.5	'48 • 5 • 13	"
Gaxiola Robees, Alvaro		M	170.0	62.0	'37 • 1 • 26	"
Guzman Torres, Alfredo		M	174.0	63.0	'43 • 2 • 6	"
Hernandez Rojas, Rafael		M	173.0	65.0	'46 • 2 • 28	"
Madrigal Garcia, Roberto		M	172.0	64.0	'41 • 4 • 20	"
Nino De Rivera, L. L.		M	176.0	62.0	'46 • 8 • 3	"
Robinson Gonzalez, J. D. J.		M	176.0	63.0	'45 • 2 • 14	"
Ruiz De Chavez Ochoa, S.		M	179.0	75.0	'48 • 12 • 5	"
Souza, Maria Luisa		F	160.0	54.0	'42 • 11 • 21	"
Andrade, W. O.	32	M	177.0	67.0	'43 • 9 • 28	Modern Pentathlon Pentathlon Moderne
Flores, E. M.	33	M	173.0	65.0	'44 • 9 • 20	"
Padilla, Enrique	34	M	171.0	66.0	'34 • 8 • 23	"
Rios, D. R.	35	M	174.0	65.0	'41 • 12 • 26	"
Fernandez Mooney, Elisa		F	163.0	59.0	'46 • 6 • 10	Equestrian Sports Sport Equestre
Figueroa Gonzalez, Hector		M	168.0	67.0	'25 • 12 • 18	"
Gonzalez Cabrera, J. R.		M	165.0	66.0	'17 • 7 • 4	"
Guasch De Las H, Ricardo		M	180.0	75.0	'33 • 11 • 10	"
Hermida Torres, Joaquin		M	169.0	66.0	'21 • 8 • 16	"
Higareda Usi, Eduardo		M	173.0	75.0	'37 • 11 • 26	"
Madrigal Polanco, Joaquin		M	170.0	75.0	'34 • 12 • 17	"
Mendivil Yocupicio, M.		M	176.0	68.0	'35 • 8 • 24	"
Uriza Castro, Ruben		M	173.0	70.0	'20 • 5 • 27	"
Zatarain Romano, Hector		M	177.0	73.0	'29 • 6 • 27	"
Elizondo Najera, Jesus A.	214	M	186.0	96.0	'30 • 10 • 30	Shooting Tir
Torres Valdez, Enrique	215	M	167.0	70.0	'28 • 7 • 31	"
Vazquez Rana, Abel	213	M	165.0	77.0	'40 • 10 • 18	"
Vazquez Rana, Olegario	212	M	172.0	78.0	'34 • 12 • 10	"
Ybarra Zapata, Raul	216	M	.	.	'08 • 4 • 6	"
Aguilar, Luis		M	183.0	85.0	'36 • 4 • 22	Yachting
Belausteguigoitia, Iker		M	178.0	78.0	'27 • 10 • 9	"
Braniff, Carlos		M	171.0	68.0	'28 • 1 • 12	"
De La Lama, Mauricio		M	179.0	76.0	'19 • 12 • 11	"
De La Lama, Victor		M	184.0	77.0	'19 • 12 • 11	"
Frias, Juan		M	173.0	73.0	'18 • 9 • 24	"
Gerard, Andres		M	175.0	76.0	'47 • 7 • 23	"
Gonzalez Karg, Sergio		M	173.0	75.0	'25 • 7 • 3	"
Mier, Felipe		M	182.0	82.0	'30 • 10 • 16	"
Ortiz Monasterio, F.		M	178.0	60.0	'23 • 7 • 23	"
Prieto Lopez, Eduardo		M	180.0	84.0	'12 • 5 • 15	"
Recamier, Antonio		M	175.0	73.0	'30 • 2 • 3	"
Serrano, Alfonso		M	181.0	74.0	'21 • 1 • 6	"

NAME NOM	NO. NO.	SEX SEXE	HEIGHT HAUTEUR	WEIGHT POIDS	DATE OF BIRTH DATE DE NAISSANCE	EVENT EPREUVE	
MONACO MONACO							
Battaglia, Rene	105	M	164.0	78.0	'39 • 11 • 27	Weight-Lifting Haltérophilie	L. Heavy
MONGOLIA MONGOLIE							
Dashzeveg, Namjilmaa	136	F	171.0	78.0	'44 • 10 • 27	Athletics Athlétisme	Shot Put, Discus Throw
Dulam, Amarsanaa	430	M	177.0	62.0	'44 • 3 • 9	"	400m, 800m
Ramazan, Aldaanish	135	F	171.0	51.0	'45 • 11 • 23	"	400m, 800m
Ianjin, Baatar	97	M	168.0	68.0	'40 • 8 • 3	Cycling Cyclisme	Road Ind., Team T. T.
Luvsan, Buudai	98	M	167.0	67.0	'40 • 3 • 8	"	Road Ind., Team T. T.
Luvsan, Erkhemjamts	99	M	162.0	64.0	'43 • 1 • 18	"	Road Ind., Team T. T.
Tchoijiljav, Samand	100	M	168.0	68.0	'37 • 2 • 4	"	Road Ind., Team T. T.
Tsagandorj, Gundigmaa	145	F	152.0	52.0	'40 • 2 • 6	Gymnastics Gymnastique	
Yadamsuren, Tuya	144	F	154.0	52.0	'47 • 11 • 6	"	
Zagdbazar, Niamdawaa	66	M	166.0	56.0	'44 • 12 • 22	"	
Baldan, Sanjaa		M	170.0	63.0		Wrestling Lutte	Free S.-Feather
Bazar, Sukhbaatar		M	166.0	57.0	'42 • 11 • 15	"	Free S.-Bantam
Danzandarjaa, Serecter		M	170.0	70.0	'43 • 4 • 3	"	Free S.-Light
Jigjidy, Monkhbat		M	174.0	78.0	'41 • 10 • 18	"	Free S.-Welter
Khorloo, Baianmonkh		M	178.0	78.0	'44 • 11 • 4	"	Free S.-Middle
Olziisaikhany, E.		M	176.0	97.0	'36 • 4 • 1	"	Free S.-L. Heavy
Tchimedbazar, D.		M	162.0	52.0	'45 • 3 • 21	"	Free S.-Fly
Tserendonoin, Sanjaa		M	184.0	97.0	'36 • 11 • 7	"	Free S.-Heavy
Lamjab, Dekhlee	217	M	.	.	'37 • 8 • 20	Shooting Tir	Free Rifle
Tubed, Miagmarjab	219	M	.	.	'41 • 2 • 3	"	Free, Rapid Fire Pistol
Tubed, Tserendondob	218	M	.	.	'34 • 5 • 1	"	Small Bore-3 P., Prone
MOROCCO MAROC							
Akka Samsam, Lahcen	435	M	191.0	106.0	'42 • 6 • 14	Athletics Athlétisme	Shot Put
Benaissa, Bakir	436	M	169.0	65.0	'32 •	"	Marathon
El Ghazi, Ben Assou	434	M	175.0	68.0	'38 •	"	5000m, 3000m S. C.
El Maachi Bouchaib, B.	433	M	173.0	68.0	'40 •	"	100m, 200m
Ahidous, Lahcen	177	M	180.0	75.0	'45 •	Boxing Boxe	Middle
Fatah, Ben Farj	176	M	172.0	63.0	'41 •	"	L. Welter
Bamous, Driss	10	M	168.0	67.0	'42 •	Football	
Bendayan, Ali	11	M	170.0	68.0	'43 •	"	
Bensiffedine, Amar	5	M	174.0	71.0	'38 •	"	
Bouachra, Ali	18	M	164.0	67.0	'40 • 9 • 8	"	
El Mansouri, Abdelghani	13	M	176.0	72.0	'42 •	"	
Fah Im, Mustapha	3	M	173.0	71.0	'38 •	"	
Kassou, Alla	1	M	178.0	74.0	'41 •	"	
Kastalani, Abdellah	2	M	171.0	70.0	'39 •	"	
Kenzzedine, Mohammed	17	M	170.0	69.0	'39 •	"	
Khanoussi, Moulay Idriss	6	M	175.0	75.0	'40 •	"	
Laghrissi, Ahmed	12	M	170.0	72.0	'37 •	"	
Lamari, Mohammed	8	M	171.0	70.0	'37 •	"	
Mohammed, Abdelkader	9	M	171.0	72.0	'35 •	"	
Mokhtatif, Abdelkader	14	M	177.0	80.0	'34 •	"	
Morchid, Abdelkader	16	M	170.0	74.0	'37 •	"	
Nafai, Sadni	7	M	173.0	72.0	'40 •	"	
Niiam, Abderrazak	4	M	172.0	72.0	'41 •	"	
Sahraoui, Mohammed	15	M	173.0	71.0	'42 •	"	
Adnan, Mustapha	106	M	163.0	82.0	'31 •	Weight-Lifting Haltérophilie	L. Heavy
Tazi, Abderahim	85	M	172.0	73.0	'38 •	"	Middle
NETHERLANDS ANTILLES ANTILLES NEERLANDAISES							
Boutmy, Jan Adolf	185	M	180.0	72.0	'30 • 12 • 10	Fencing Escrime	Sabre Ind.
Curriel, Hector Publio	10	M	168.0	56.0	'36 • 11 • 2	Weight-Lifting Haltérophilie	Bantam
Monk, Rudy Ernst	71	M	163.0	67.5	'36 • 1 • 26	"	Light
Rijna, Fortunato Theodoro	107	M	172.0	82.5	'38 • 5 • 29	"	L. Heavy
NORTHERN RHODESIA RHODESIE DU NORD							
Babb, Walter Delville	461	M	186.8	74.8	'40 • 12 • 3	Athletics Athlétisme	110m Hurdles

NAME NOM	NO. NO.	SEX SEXE	HEIGHT HAUTEUR	WEIGHT POIDS	DATE OF BIRTH DATE DE NAISSANCE	EVENT EPREUVE	
Chifita, Laurent Daniel	464	M	167.5	55.8	'43 • 8 • 3	Athletics Athlétisme	Marathon
Haynes, Trevor S. A	463	M	179.0	62.5	'29 • 11 • 17	"	Marathon
Kapambwe, Constantino	465	M	162.5	56.8	'40 • 7 • 21	"	Marathon
Smith, Jeffery Itzen	462	M	181.5	77.0	'43 • 6 • 11	"	100m, 200m
Crawford, Brian David		M	182.8	68.0	'44 • 12 • 31	Rowing Aviron	Single Sculls
McLoughlin, Ian William	186	M	167.5	56.8	'44 • 6 • 7	Boxing Boxe	Feather
Van Der Walt, C. M.	185	M	163.8	53.5	'43 • 8 • 13	"	Bantam
Skinner, Patricia C.	186	F	162.5	57.0	'30 • 5 • 12	Fencing Escrime	Foil Ind.
Smith, John Alan		M	174.0	63.5	'42 • 9 • 25	Wrestling Lutte	Free S-Feather
Van Wyk, Theunis G.		M	185.5	84.5	'44 • 3 • 21	"	Free S-Middle
Durrett, Alan Hugh		M	180.0	77.5	'48 • 1 • 13	Swimming and Diving Natation et Plongeon	400m, 1500m Free
Fox, Charles Wanne		M	181.5	71.0	'48 • 4 • 6	"	200m Breast, 400m Ind. Medley
NEPAL NEPAL							
Bhupendra, Bahadur K. C.	845	M	.	.	'35 •	Athletics Athlétisme	Marathon
Ganga, Bahadur Thada	846	M	.	.	'35 •	"	Marathon
Bhimbahadur, Gurung	188	M	161.0	56.1	'44 •	Boxing Boxe	Feather
Namsing, Thapa	187	M	155.0	50.8	'46 • 8 • 8	"	Fly
Omparsad, Pun	190	M	160.0	63.5	'42 •	"	L. Welter
Ramparsad, Gurung	189	M	160.0	60.3	'45 •	"	Light
NETHERLANDS HOLLANDE							
Bijlevelo, Johanna C. A.	142	F	175.0	63.0	'40 • 10 • 7	Athletics Athlétisme	100m, Long Jump
Hinten, Amelia A. J.	146	F	168.0	60.0	'42 • 8 • 26	"	80m Hurdles, Pentathlon
Kamerbeek, Evert	455	M	189.0	94.0	'34 • 3 • 17	"	Decathlon
Kochj Cornelis	454	M	191.0	115.0	'36 • 7 • 16	"	Discus Throw
Kraan, Gerarda Maria	145	F	173.0	60.0	'33 • 7 • 30	"	800m
Luijjes, Franciscus J.	453	M	183.0	72.0	'44 • 6 • 21	"	100m, 200m
Van Der Zwaard, M. C.	143	F	168.0	59.5	'38 • 1 • 18	"	400m
Van Fyck-Vos, Jannie	144	F	168.0	60.0	'36 • 1 • 19	"	800m
Alwin, Max Bruno.		M	185.0	82.0	'39 • 6 • 17	Rowing Aviron	Double Sculls
Blaisse, Steven Joseph		M	181.0	75.0	'40 • 5 • 7	"	Pair, Without Cox
Boelen, Herman		M	190.0	76.0	'39 • 5 • 12	"	Four, Without Cox
Bos, Jan Jaspers		M	169.0	50.0	'39 • 7 • 28	"	Pair, With Cox
Bots, Peter Frits		M	182.0	73.0	'42 • 1 • 25	"	Double Sculls
Castelein, Sipke Taeke		M	193.0	77.0	'41 • 4 • 14	"	Four, Without Cox
Den Hartog, Arie		M	183.0	85.0	'29 • 11 • 13	"	Reserve, Oarsmen
Enters, Jaap		M	176.0	72.0	'39 • 11 • 8	"	Four, Without Cox
Groen, Robert Jacques		M	185.0	81.0	'38 • 2 • 18	"	Single Sculls
Hartsuiker, Frederik K. J.		M	189.0	83.0	'40 • 10 • 19	"	Pair, With Cox
Jansen, Bernard R. H.		M	187.0	76.0	'41 • 2 • 8	"	Reserve, Oarsmen
Klumperbeek, Marius P. L.		M	164.0	48.0	'38 • 8 • 7	"	Four, With Cox
Mullink, Alex Gerhard		M	189.0	90.0	'44 • 12 • 19	"	Four, With Cox
Pennink Johan Willem		M	185.0	75.0	'29 • 3 • 31	"	Reserve, Cox
Rouwe, Herman Jan		M	179.0	82.0	'43 • 1 • 20	"	Pair, With Cox
Statema, Eke		M	184.0	82.0	'33 • 9 • 15	"	Reserve, Oarsmen
Van De Graaf, Robert		M	189.0	82.0	'44 • 3 • 17	"	Four, With Cox
Van De Graaff, F. R.		M	187.0	92.0	'44 • 2 • 20	"	Four, With Cox
Van De Graaff, Jan		M	193.0	92.0	'44 • 9 • 24	"	Four, With Cox
Veenemans, Ernst Willem		M	188.0	77.0	'40 • 3 • 18	"	Pair, Without Cox
Wartena, Sjoerd		M	189.0	76.0	'39 • 5 • 1	"	Four, Without Cox
De Rooij, Johannes	192	M	167.0	57.0	'32 • 1 • 26	Boxing Boxe	Feather
Gerlach, Willem Aldert	193	M	174.0	63.5	'35 • 6 • 26	"	L. Welter
Huppen, Jan	191	M	160.0	54.0	'42 • 9 • 24	"	Bantam
Lubbers, Rudolfus J. M.	194	M	182.0	81.0	'45 • 8 • 17	"	L. Heavy
Geurts, Antonius Johannes	97	M	183.0	85.0	'32 • 2 • 29	Canoeing Canotage	Kayak 1, 2
Hoekstra, Paul Joan	98	M	176.0	80.0	'44 • 12 • 30	"	Kayak 2, 4
Lagrand, Cees Willem	99	M	182.0	83.0	'36 • 10 • 20	"	Reserve
Van Halteren, Theodorus	100	M	173.0	68.0	'38 • 6 • 15	"	Kayak 4
Weijzen, Gug. H.	101	M	174.0	89.0	'35 • 1 • 21	"	Kayak 4
Wittenberg, Jan Willem	102	M	181.0	80.0	'43 • 2 • 26	"	Kayak 4
Cornelisse, Hendrik J. W.	101	M	178.0	72.0	'40 • 10 • 16	Cycling Cyclisme	Ind. Road

NAME NOM	NO. NO.	SEX SEXE	HEIGHT HAUTEUR	WEIGHT POIDS	DATE OF BIRTH DATE DE NAISSANCE	EVENT EPREUVE
De Graaf, Arie	119	M	176.0	74.0	'39 • 10 • 22	Cycling Scratch, Tandem Sprint
Dolman, Evert Gerardus	92	M	177.5	71.0	'46 • 2 • 22	" Road Team T. T.
Groen, Tiemen	121	M	185.0	85.0	'46 • 7 • 6	" Ind. Pursuit
Karstens, Gerben	102	M	178.0	74.0	'42 • 1 • 14	" Road Ind., Team T. T.
Koel, Gerard Hendrik	115	M	179.0	67.0	'41 • 1 • 16	" Team Pursuit
Nikkessen, Theo H. A.	116	M	182.0	78.0	'41 • 8 • 18	" Team Pursuit
Oudkerk, Jacob	117	M	181.0	70.0	'37 • 8 • 2	" Team Pursuit
Pieterse, Johannes A. M.	94	M	175.0	70.0	'42 • 10 • 29	" Road Team T. T.
Schuuring, Cornelis	118	M	186.0	81.0	'42 • 3 • 30	" Team Pursuit
Steevens, Henri	103	M	178.0	73.0	'45 • 4 • 27	" Ind. Road
Van Der Touw, Pieter C. C.	120	M	184.0	78.0	'40 • 11 • 29	" 1000m T. T., Scratch, Tandem Sprint
Zoet, Hubertus Balthazar	104	M	176.0	77.0	'42 • 10 • 20	" Road Ind., Team T. T.
Boks, Joost,	1	M	186.0	84.0	'42 • 4 • 17	Hockey
Coster Van Voorhout, C. V.	2	M	175.0	74.0	'42 • 3 • 31	"
De Keyzer, Arie Leendert	8	M	180.0	72.0	'43 • 6 • 1	"
Elffers, John Robert	3	M	175.0	72.5	'43 • 12 • 24	"
Fiolet, Franciscus A.	4	M	183.0	82.0	'39 • 7 • 20	"
Fokker, Johan Pieter	5	M	184.0	81.0	'42 • 1 • 19	"
Krol, Leendert Gerhardus	9	M	185.0	80.0	'39 • 11 • 30	"
Leemhuis, Jacob Pieter	10	M	191.0	85.0	'41 • 12 • 4	"
Mijnarends, Johan C.	11	M	178.0	74.0	'39 • 8 • 8	"
Spits, Nicolaas Bernard	14	M	185.0	80.0	'43 • 4 • 7	"
Terlingen, Theodorus B. M.	15	M	182.0	74.0	'39 • 5 • 26	"
Van Gooswilligen, Jan C.	6	M	189.0	87.0	'35 • 7 • 12	"
Van Russem, Erik	12	M	175.0	68.0	'38 • 10 • 12	"
Van T Hooft, Jan Francis	7	M	170.0	63.0	'40 • 1 • 3	"
Van Vroonhoven, Th. J. M. V.	18	M	180.0	77.0	'40 • 5 • 15	"
Veenster, Jan	16	M	180.0	75.0	'38 • 2 • 13	"
Voigt, Jacob	17	M	182.0	78.0	'41 • 6 • 7	"
Zweerts, Guillaume F.	19	M	186.0	84.0	'43 • 6 • 29	"
Geesink, Antonius J.		M	196.0	120.0	'34 • 4 • 6	Judo All Weights
Gouweleeuw, Job Johannes		M	183.0	100.0	'40 • 9 • 5	" Heavy Weight
Snijders, Johannes H. C.		M	183.0	80.0	'43 • 9 • 14	" Middle Weight
Snijders, Petrus H. C.		M	182.0	80.0	'43 • 9 • 14	" Middle Weight
Beumer, Catharina Johanna		F	173.0	67.0	'47 • 7 • 5	Swimming and Diving 100m, 4X100m Free
Bimolt, Klena Greetje		F	173.0	67.0	'45 • 6 • 8	Natation et Plongeurs 200m Breast, 4X100m Medley
Bontekoe, Johan Klaas		M	193.0	89.0	'43 • 7 • 1	" 400m, 4X100m, 4X200m Free
Heemskerck, Marienne Y.		F	154.0	59.0	'44 • 8 • 28	" 400m Ind. Medley
Heukels, Elizabeth Anna		F	171.0	63.0	'42 • 2 • 25	" 400m Ind., 4X100m Medley
Jiskoot, Johannes		M	177.0	75.0	'40 • 3 • 3	" 400m Ind. Medley, 4X100m Free, Medley
Kok, Ada		F	183.0	80.0	'47 • 6 • 6	" 100m Butterfly, 4 x 100m Medley
Kok, Margretha		F	176.0	71.0	'44 • 10 • 16	" 200m Breast
Kroon, Ronald		M	186.0	72.0	'42 • 9 • 17	" 100m, 4X100m, 4X200m Free
Langerhorst, Dirk F. A.		M	181.0	78.0	'46 • 3 • 26	" 4X100m Medley
Lasterie, Aartje E.		F	171.0	65.0	'43 • 12 • 16	" 200m Butterfly, 4X200m Free
Looijs, Geertruida		F	176.0	66.0	'46 • 6 • 26	" 100m Butterfly, 400m Ind, Medley
Mensonides, Wieger Emile		M	178.0	80.0	'38 • 7 • 12	" 200m Breast
Oudt, Adriaan Frederik		M	181.0	83.0	'46 • 2 • 26	" 200m Breast, 4X100m Medley
Sitters, Bertus		M	177.0	74.0	'41 • 12 • 10	" 400m, 4X200m Free
Terpstra, Erica Georgine		F	175.0	74.0	'43 • 5 • 26	" 100m, 4X100m Free, Medley
Tigelaar, Willemina H.		F	167.0	58.5	'45 • 10 • 9	" 400m Free
Van Baalen, Levinus W.		M	187.0	76.0	'42 • 7 • 1	" 100m, 4X100m Free
Van Der Wildt, Paulina J.		F	177.0	72.5	'44 • 1 • 29	" 4X100m Free
Van Osch, Henri		M	178.0	70.0	'45 • 4 • 12	" 200m Back, 4X100m Medley
Van Velsen, Maria Martina		F	175.0	68.0	'43 • 3 • 22	" 100m Back, 4X100m Medley
Van Weerdenburg, W.		F	168.0	61.0	'46 • 10 • 1	" 100m, 4X100 Free
Vriens, Hermanus S. A.		M	190.0	90.0	'44 • 6 • 10	" 200m Breast, 4X100m Medley
Weeteling, Albertha		F	165.0	53.0	'46 • 12 • 28	" 400m, 4X100m Free, 100m Back
Weeteling, Jan		M	191.0	70.0	'40 • 8 • 18	" 200m Back, 4X100m Medley
Winkel, Kornelia		F	170.0	63.5	'44 • 2 • 26	" 100m Back, 4X100m Medley

NAME NOM	NO. NO.	SEX SEXE	HEIGHT HAUTEUR	WEIGHT POIDS	DATE OF BIRTH DATE DE NAISSANCE	EVENT EPREUVE	
Van Domselaar, Johan	231	M	183.0	92.0	'28 • 9 • 11	Shooting Tir	Small Bore-3 P., Prone
Constandse, Franklin L.	12	M	192.0	76.0	'46 • 5 • 31	Volley-Ball	
De Vink, Jacques	8	M	186.0	74.0	'42 • 6 • 15	"	
Ewalds, Jacques	10	M	180.0	76.0	'40 • 2 • 28	"	
Groenhuijzen, Robert G.	5	M	187.0	85.0	'41 • 3 • 4	"	
Koolen, Jurjaan C.	2	M	186.0	76.0	'38 • 9 • 20	"	
Korsloot, Jacob	1	M	180.0	69.0	'34 • 5 • 9	"	
Oosterbaan, Jan Martinus	4	M	184.0	68.0	'37 • 11 • 10	"	
Swieter, Pieter	6	M	191.0	83.0	'43 • 4 • 22	"	
Tinkhof, Johannes G. G.	3	M	180.0	67.0	'38 • 3 • 22	"	
Van Der Hoek, Johannes	11	M	185.0	80.0	'40 • 2 • 14	"	
Van Der Stoep, Dingeman	9	M	181.0	71.0	'39 • 4 • 6	"	
Van Wijnen, Johan Wilhelm	7	M	178.0	72.0	'37 • 12 • 30	"	
Bultman, Jan Arend		M	173.0	70.0	'42 • 5 • 26	Water Polo	
Hermesen, Hendrik Willem		M	182.0	81.0	'37 • 8 • 29	"	
Kniest, Lambertus G.		M	184.0	90.0	'27 • 8 • 14	"	
Leenards, Abraham C. W.		M	188.0	83.0	'40 • 1 • 14	"	
Muller, Johan Arnoldus		M	178.0	79.0	'37 • 1 • 24	"	
Van Der Voet, Nicolaas M.		M	187.0	86.5	'44 • 3 • 13	"	
Van Dorp, Alfred Carel		M	190.0	93.0	'38 • 10 • 13	"	
Van Spingelen, Willem		M	184.0	79.0	'38 • 2 • 19	"	
Vriend, Henri Gerard		M	176.0	72.0	'38 • 5 • 20	"	
Vriend, Willem Jan F.		M	176.0	72.0	'41 • 11 • 9	"	
Wormgoor, Gerardus H.		M	188.0	73.0	'40 • 7 • 21	"	
De Jong, Nicolaas Pieter		M	184.0	83.5	'42 • 3 • 22	Yachting	F. Dutchman
Groot, Cornelis		M	182.0	82.0	'09 • 1 • 21	"	Reserve
Jager, Ulrik		M	184.0	85.0	'28 • 7 • 14	"	Reserve
Jongkind, Jan Marinus		M	178.0	70.5	'32 • 9 • 19	"	Dragon
Scholtz, Hendrik Jacobus		M	178.0	86.0	'11 • 1 • 30	"	Dragon
Van Duyl, Willem Paul		M	189.0	94.0	'20 • 5 • 24	"	Dragon
Verhagen, Gijsbertus		M	180.0	86.0	'26 • 9 • 29	"	F. Dutchman
Wayboer, Dirk		M	182.0	90.0	'36 • 5 • 11	"	Reserve
Willems, Hans		M	172.0	80.0	'34 • 3 • 22	"	Finn
NIGER NIGER							
Dabore, Issaka	195	M	164.0		'40 •	Boxing Boxe	Welter
NIGERIA NIGERIA							
Ahanotu, Clarice	137	F	165.1	51.3	'39 • 7 • 27	Athletics Athlétisme	100m, 200m
Akika, Edward	438	M	176.0	66.2	'41 • 7 • 18	"	110m Hurdles
Akpata, Sungay	446	M	185.4	72.5	'37 • 2 • 16	"	Long Jump
Amu, Abdul	440	M	185.4	77.3	'33 • 11 • 13	"	4X100m
Asiodu, Sydney	441	M	180.6	72.5	'44 • 1 • 28	"	4X100m
Ejoke, David	437	M	178.0	71.6	'36 • 11 • 8	"	100m, 200m, 4X100m
Erinle, Folu	439	M	175.4	69.9	'40 • 1 • 29	"	110m Hurdles, 4X100m
Igun, Samue	444	M	178.0	74.4	'38 • 2 • 28	"	High Jump
Ogan, George	447	M	172.7	66.7	'38 • 7 • 20	"	Long Jump, Triple Jump
Ohiri, Christian	847	M				"	Triple Jump
Okoli, Amelia	138	F	170.2	63.5	'41 • 5 • 14	"	High Jump
Okorafor, Lawrence	442	M	172.7	61.3	'39 • 1 • 10	"	4X100m
Omagbemi, Jimmy	443	M	178.0	69.9	'30 • 11 • 26	"	4X100m
West, Wariboko	445	M	175.4	66.2	'42 • 8 • 19	"	Long Jump
Alimi, Sikiru	198	M	175.0	67.2	'42 • 9 • 22	Boxing Boxe	Welter
Andeh, Anthony	197	M	175.4	57.2	'45 • 8 • 16	"	Feather
Maiyegun, Nojim	199	M	170.0	70.4	'41 • 2 • 17	"	L. Middle
Young, Karimu	196	M	167.6	53.1	'42 • 3 • 21	"	Bantam
NORWAY NORVEGE							
Benum, Pal	458	M	179.0	67.0	'35 • 8 • 3	Athletics Athlétisme	10000m
Berthelsen, Berit	147	F	171.0	63.0	'44 • 4 • 24	"	200m, Long Jump
Helland, Thor	456	M	178.0	65.0	'36 • 12 • 12	"	5000m
Hokland, Oddrun Helene	148	F	162.0	58.0	'42 • 11 • 29	"	Long Jump, Pentathlon

NAME NOM	NO. NO.	SEX SEXE	HEIGHT HAUTEUR	WEIGHT POIDS	DATE OF BIRTH DATE DE NAISSANCE	EVENT EPREUVE	
Pedersen, Teje Olav	460	M	193.0	93.0	'43 • 2 • 9	Athletics Athlétisme	Javelin Throw
Rasmussen, Willy Lorang	459	M	187.0	85.0	'37 • 12 • 3	"	Javelin Throw
Ahlsand, Tor		M	186.0	78.0	'31 • 8 • 22	Rowing Aviron	Four. With Cox
Brodtkorb, Eilif Magnus		M	186.0	83.0	'36 • 7 • 18	"	Four, With Cox
Knudtzon, Jens Birger		M	181.0	83.0	'36 • 2 • 19	"	Four, With Cox
Kristiansen, Ingolf		M	183.0	78.0	'38 • 6 • 10	"	Four, With Cox
Nilsen, Thor Sverre		M	187.0	84.0	'31 • 10 • 5	"	Reserve, Cox
Syvtersen, Rolf		M	164.0	47.0	'48 • 10 • 18	"	Four, With Cox
Storhaug, Age	61	M	177.0	67.0	'38 • 4 • 5	Gymnastics Gymnastique	
Wigaard, Harald	62	M	182.0	67.0	'44 • 5 • 17	"	
Barlie, Harald		M	178.0	78.0	'37 • 1 • 4	Wrestling Lutte	Free S., Greco R.-Welter
Landroe, Magne	220	M	.	.	'37 • 8 • 24	Shooting Tir	Free Rifle, Small Bore-3 P., Prone
Naes, Thormod	221	M	.	.	'30 • 4 • 12	"	Free Rifle, Small Bore-Prone
Zwetnow, Nicolaus	222	M	.	.	'29 • 5 • 18	"	Rapid Fire Pistol
Bengtsson, Knut		M	172.0	85.0	'19 • 6 • 3	Yachting	Dragon
Crown Prince, Harald		M	186.0	84.0	'37 • 2 • 21	"	5.5m
Foyen, Stein		M	185.0	84.0	'35 • 2 • 11	"	5.5m
Johannessen, Eirik		M	172.0	72.0	'33 • 7 • 30	"	5.5m
Jordbakke, Per		M	180.0	81.0	'32 • 3 • 14	"	Finn
Koefoed, Einar		M	174.0	74.0	'42 • 3 • 22	"	F. Dutchman
Linge, Jan Herman		M	178.0	82.0	'22 • 1 • 28	"	Reserve
Ly, Egil Normann		M	186.0	85.0	'38 • 10 • 31	"	Dragon
Mehren, Hans Preben		M	186.0	78.0	'45 • 1 • 24	"	F. Dutchman
Mortensen, Ole Theodor		M	183.0	67.0	'18 • 7 • 6	"	Reserve
Orner, Jan		M	183.0	75.0	'24 • 4 • 27	"	Reserve
Skaugen, Morits		M	191.0	98.0	'20 • 6 • 27	"	Dragon
NEW ZEALAND NOUVELLE-ZELANDE							
Baillie, William David	468	M	169.0	65.0	'34 • 5 • 28	Athletics Athlétisme	5000m, 10000m
Chamberlain, Ann M.	151	F	170.0	54.0	'35 • 12 • 5	"	800 m
Davies, John Llewellyn	467	M	185.0	68.0	'38 • 5 • 25	"	1500m
Halberg, Murray Gordon	469	M	178.0	62.0	'33 • 7 • 7	"	5000m, 10000m
Julian, Jeffrey Lynn	473	M	174.0	60.0	'35 • 10 • 9	"	Marathon
Keats, Ivan	474	M	165.0	60.0	'37 • 4 • 16	"	Marathon
Magee, Arthur Barry	471	M	173.0	58.0	'34 • 2 • 6	"	10000m
McIntosh, Avis	149	F	166.0	57.0	'38 • 5 • 19	"	100m, 80m Hurdles
Mills, Leslie R.	472	M	189.0	120.0	'34 • 11 • 1	"	Shot Put, Discus Throw
Porter, Doreen Helen	150	F	176.0	67.0	'41 • 7 • 21	"	100m, 200m
Puckett, Raymond Leslie	475	M	166.0	58.0	'35 • 12 • 17	"	Marathon
Scott, Neville Ian	470	M	187.0	74.0	'35 • 2 • 25	"	5000m
Snell, Peter George	466	M	179.0	.	'38 • 12 • 17	"	800m, 1500m
Young, Isobel Margaret	152	F	180.0	75.0	'37 • 8 • 10	"	Shot Put, Discus Throw
Boswell, Darien Graham		M	191.0	83.0	'38 • 5 • 23	Rowing Aviron	Four, With Cox
Brownlee, Mark		M	187.0	90.0	'42 • 11 • 26	"	Eight, With Cox
Clark, Alexander Grant		M	191.0	85.0	'43 • 2 • 20	"	Eight, With Cox
Delaney, Peter		M	187.0	84.0	'41 • 9 • 9	"	Eight With Cox
Dryden, Alistair Garth		M	194.0	91.0	'42 • 12 • 18	"	Four, With Cox
Gibbons, John Greville		M	193.0	95.0	'43 • 6 • 19	"	Eight, With Cox
Little, James Robert		M	180.0	88.0	'43 • 12 • 1	"	Reserve, Oasmen
Masfen, Peter Hanbury		M	189.0	88.0	'41 • 8 • 9	"	Four, With Cox
Moselen, David John		M	183.0	86.0	44 • 12 • 8	"	Reserve, Oarsmen
Page, Robert Edward		M	165.0	75.0	'36 • 9 • 14	"	Four, With Cox
Paterson, George Murray		M	184.0	83.0	'40 • 11 • 6	"	Eight, With Cox
Popplewell, Anthony		M	194.0	88.0	'41 • 5 • 1	"	Eight, With Cox
Pulman, Douglas William		M	166.0	75.0	'46 • 1 • 1	"	Eight, With Cox
Skinner, Raymond Leslie		M	187.0	85.0	'40 • 10 • 15	"	Eight, With Cox
Storey, Dudley Leonard		M	179.0	81.0	'39 • 11 • 27	"	Four, With Cox
Watkinson, Murray P.		M	185.0	84.0	'39 • 6 • 11	"	Single Sculls
Webster, Alan John		M	183.0	83.0	'41 • 8 • 18	"	Eight, With Cox
Donovan, Thomas Patrick	200	M	165.0	59.0	'36 • 12 • 23	Boxing Boxe	Light

NAME NOM	NO. NO.	SEX SEXE	HEIGHT HAUTEUR	WEIGHT POIDS	DATE OF BIRTH DATE DE NAISSANCE	EVENT EPREUVE	
Maunsell, Brian Martin	201	M	166.0	63.0	'37 • 10 • 5	Boxing	L. Welter
Byers, Laurence John	105	M	185.0	78.0	'41 • 3 • 3	Cycling	Road Ind., Team T. T.
Candy, William Arthur F.	97	M	175.0	81.0	'34 • 6 • 19	Cyclisme	Road Team T. T.
Grace, Max William	106	M	180.0	69.0	'42 • 12 • 14	"	Road Ind., Team T. T.
Johnstone, Richard Davis	107	M	184.0	78.0	'36 • 6 • 23	"	Road Ind., Team T. T.
Thomson, Desmond Ronald	108	M	179.0	70.0	'42 • 8 • 22	"	Ind. Road
Gardiner, Pauline Margrit	181	F	167.0	59.0	'45 • 10 • 11	Gymnastics	
Hill, Theodora Mary	183	F	163.0	62.0	'46 • 1 • 11	Gymnastique	
Spencer, Jean Charlotte	182	F	165.0	60.0	'40 • 6 • 10	"	
Oliver, Donald Carthew	152	M	191.0	87.0	'37 • 4 • 16	Weight-Lifting	Heavy
Anslow, John	10	M	166.0	73.0	'35 • 10 • 6	Haltérophilie	
Barnes, Ernest	7	M	175.0	75.0	'37 • 4 • 20	Hockey	
Best, Matthew Robert	20	M	.	.	'39 • 2 • 29	"	
Blake, Trevor William	18	M	171.0	72.0	'37 • 3 • 13	"	
Byers, Peter William	12	M	183.0	87.0	'44 • 2 • 14	"	
Bygrave, Phillip George	17	M	182.0	73.0	'29 • 9 • 19	"	
Carter, Timothy Joseph	4	M	169.0	73.0	'44 • 6 • 24	"	
Cullen, John Cameron	6	M	173.0	67.0	'37 • 9 • 14	"	
Free, Ian H.	21	M	.	.	'41 • 4 • 4	"	
Gillespie, John Ross	5	M	173.0	68.0	'35 • 6 • 2	"	
Judge, Bruce Raymond	8	M	183.0	76.0	'42 • 4 • 3	"	
Judge, Charles Grantley	11	M	185.0	73.0	'40 • 5 • 7	"	
Kerr, John	3	M	183.0	70.0	'35 • 2 • 10	"	
Maunsell, Brian Robert	9	M	182.0	71.0	'35 • 10 • 16	"	
McPherson, Ross James	22	M	.	.	'38 • 10 • 24	"	
Palmer, James Moray	23	M	.	.	'39 • 3 • 1	"	
Patterson, Alan Joseph	2	M	175.0	74.0	'41 • 1 • 19	"	
Schaefer, William Paul	1	M	171.0	74.0	'25 • 10 • 9	"	
Greig, Anthony Granville		M	175.0	69.0	'41 • 7 • 22	Wrestling	Free S.-Light
Meehan, Athol Roy		M	168.0	65.0	'31 • 7 • 21	Lutte	Free S.-Feather
Gerrard, David Francis		M	170.0	77.0	'45 • 4 • 3	Swimming and Diving	200m Butterfly
Haddon, Vivien Joan		F	175.0	73.0	'45 • 8 • 14	Natation et Plongeon	200m Breast
Hansen, Graeme Otto		M	175.2	70.9	'34 • 3 • 20	Equestrian Sports	Jumping Grand Prix
Hansen, Richard Bruce		M	174.0	70.0	'28 • 2 • 14	Sport Equestre	Jumping Grand Prix
Mathews, Charles H.		M	177.8	76.8	'43 • 1 • 2	"	Jumping Grand Prix
White, Adrian Patrick K.		M	180.4	68.2	'33 • 4 • 21	"	Jumping Grand Prix
De Thler, Bret Geoffrey		M	185.0	79.5	'45 • 6 • 14	Yachting	Reserve
Mander, Peter Garth		M	180.5	84.0	'28 • 7 • 4	"	Finn
Pedersen, Helmer Orlaf L.		M	180.3	80.0	'30 • 3 • 28	"	F. Dutchman
Roberts, Ralph Hamilton		M	184.0	80.0	'35 • 9 • 26	"	Reserve
Wells, Earle Leonard		M	185.4	87.0	'33 • 10 • 27	"	F. Dutchman
PUERTO RICO PORTO RICO							
Cruz, David Samuel	526	M	190.5	72.6	'43 • 12 • 18	Athletics	Long Jump
Cruz, Heriberto	524	M	180.3	72.6	'39 • 3 • 22	Athlétisme	110m Hurdles
Cruz, Rolando	525	M	180.0	70.3	'39 • 9 • 17	"	Pole Vault, Marathon
Fornes, Abraham	528	M	175.3	56.7	"	"	Marathon
Reinosa, Ignacio	527	M	182.8	86.2	'44 • 5 • 9	"	Discus Throw
Sabater, Arnaldo	523	M	180.3	72.6	'45 • 9 • 11	"	110m Hurdles
Adorno Melendez, Ruben	6	M	195.6	81.7	'41 • 8 • 3	Basket-Ball	
Anza Ortiz, Martin	10	M	180.3	70.3	'41 • 9 • 27	"	
Baez Marino, Juan Ramon	12	M	188.0	81.7	'35 • 4 • 14	"	
Cancel Acevedo, Angel	14	M	188.0	84.8	'40 • 8 • 2	"	
Cruz Downs, Teofilo	7	M	203.2	94.8	'42 • 1 • 8	"	
Droz Ramos, Evelio	5	M	190.5	83.9	'37 • 5 • 10	"	
Frontera Colley, Jaime	11	M	190.5	90.7	'40 • 11 • 30	"	
Garcia Lucas, Angel	13	M	188.0	79.4	'41 • 12 • 8	"	
Gutierrez Ferrer, Tomas	15	M	182.9	76.7	'40 • 12 • 29	"	
McCadney, William	4	M	200.7	95.3	'35 • 2 • 5	"	
Vicens Sastre, Juan	8	M	175.3	80.7	'34 • 9 • 7	"	

NAME NOM	NO. NO.	SEX SEXE	HEIGHT HAUTEUR	WEIGHT POIDS	DATE OF BIRTH DATE DE NAISSANCE	EVENT EPREUVE	
Zamot Bula, Alberto	9	M	177.8	72.1	'42 • 11 • 19	Basket-Ball	
Nieves, Jose Alonso	202	M	167.5	56.8	'44 • 1 • 23	Boxing Boxe	Feather
Baez, Fernando Luis	26	M	157.4	55.5	'41 • 7 • 25	Weight-Lifting Haltérophilie	Bantam
Pagan, V. A.	87	M	172.7	71.3	'39 • 2 • 20	"	Middle
Serrano, Pedro	51	M	167.6	61.0	'31 • 11 • 9	"	Feather
Torres, F.	129	M	174.0	90.0	'41 • 12 • 14	"	M. Heavy
Anderson, Jerry H.		M	172.7	70.4	'32 • 2 • 23	Swimming and Diving Natation et Plongeon	Springboard, High Diving
Chenau, H. Eliot		M	172.7	67.3	'47 • 4 • 11	"	400m, 1500m Free, 200m Breast, 200m Back, 400m Ind. Medley
Harding, Margaret		F	172.7	56.9	'48 • 2 • 22	"	100m Free, 200m Breast, 100m Back, 100m Butterfly, 400m Ind. Medley
Lallande, Ann		F	165.1	52.3	'49 • 6 • 24	"	100m, 400m Free, 100m Butterfly
Perez, Celestino		M	177.8	75.0	'48 • 2 • 24	"	100m, 400m, 1500m Free, 400m Ind. Medley.
Guillermety, Fred A.	255	M	178.0	75.0	'18 • 6 • 2	Shooting Tir	Free Pistol
Loyola, Jaime	47	M	180.0	102.0	'31 • 5 • 27	"	Clay Pigeon
Lyon, Leon	256	M	173.0	65.0	'18 • 8 • 3	"	Rapid Fire Pistol
Torres, Miguel R.	48	M	167.5	90.0	1898 • 9 • 2	"	Clay Pigeon
Torruellas, Juan Rafael		M	189.2	86.4	'33 • 6 • 7	Yachting	Finn
PAKISTAN PAKISTAN							
Awan, Manzoor Ul Haq	480	M	183.0	83.0	'42 • 1 • 2	Athletics Athlétisme	400m Hurdles,
Khan, Anar	478	M	176.0	70.0	"	"	800m, 1500m
Raziq, Ghulam	479	M	184.0	82.5	'32 • 11 • 11	"	110m Hurdles
Sadiq, Muhammad	477	M	183.0	88.0	'38 • 9 • 29	"	400m
Shah, Iftikhar	476	M	171.0	72.5	'40 • 8 • 14	"	100m, Long Jump
Shah, Mubarak	481	M	172.5	70.0	'30 • 6 • 30	"	3000m S. C.
Yusaf, Muhammad	482	M	179.0	70.0	'28 • 1 • 10	"	Marathon
Ali, Barkat	205	M	190.0	80.5	'35 • 6 • 1	Boxing Boxe	L. Heavy
Mahmud, Sultan	204	M	186.0	74.5	'35 • 5 • 15	"	Middle
Rehman, Abdul	206	M	195.0	83.0	'38 • 4 • 14	"	Heavy
Sarwar, Ghulam	203	M	172.0	59.5	'35 • 10 • 25	"	Light
Ashique, Muhammad	122	M	181.0	72.0	'35 •	Cycling Cyclisme	Scratch Sprint Ind., Team Pursuit
Bux, Lal	123	M	164.0	65.0	'43 •	"	Team Pursuit
Hafeez, Muhammad	124	M	172.0	78.0	'43 •	"	1000m T. T., Scratch Sprint,
Saeed, Muhammad	126	M	169.5	71.5	'37 •	"	Team Pursuit
Shaffi, Muhammad	125	M	169.0	64.0	'33 • 6 • 15	"	Reserve
Azam, Muhammad	12	M	159.0	56.0	'43 • 8 • 5	Weight-Lifting Haltérophilie	Bantam
Aizal, Muhammad	17	M	173.4	76.4	'38 • 12 • 10	Hockey	
Ahmad, Anwar	5	M	178.5	81.5	'33 • 9 • 24	"	
Ahmad, Munir	2	M	170.9	73.0	'35 • 3 • 28	"	
Ahmad, Zafar	14	M	173.4	70.5	'29 • 12 • 14	"	
Anwar, Saeed	4	M	170.9	66.0	'43 • 10 • 17	"	
Asad, Muhammad	10	M	168.3	73.0	'41 • 10 • 30	"	
Atif, Manzoor Hussain	3	M	186.2	79.4	'28 • 11 • 4	"	
Azam, Khurshid	9	M	170.9	67.0	'42 • 6 • 16	"	
Aziz, Tariq	13	M	173.4	72.0	'38 • 2 • 5	"	
Din, Zaka	8	M	168.3	68.0	'36 • 10 • 27	"	
Hamid, Abdul	12	M	163.3	63.5	'42 • 7 • 7	"	
Hayat, Zafar	15	M	181.1	82.0	'37 • 3 • 31	"	
Hussain, Mazhar	1	M	181.1	88.0	'30 • 3 • 15	"	
Mahmood, Khalid	7	M	173.4	72.5	'42 • 12 • 25	"	
Nawaz, Khizar	18	M	169.8	68.0	'42 • 9 • 20	"	
Niazi, Tariq	16	M	178.0	77.0	'40 • 3 • 15	"	
Rashid, Muhammad	6	M	181.0	72.0	'41 • 4 • 14	"	
Ullah, Muti	11	M	178.5	75.0	'38 • 1 • 31	"	
Afzal, Muhammad		M	169.0	78.0	'39 • 4 • 7	Wrestling Lutte	Free S.-Welter
Akhtar, Muhammad		M	166.0	63.0	'30 •	"	Free S.-Feather
Bashir, Muhammad		M	169.0	70.0	'35 • 3 • 10	"	Free S.-Light
Din, Siraj		M	163.0	57.0	'35 •	"	Free S.-Bantam
Muhammad, Faiz		M	178.0	87.0	'37 • 9 • 23	"	Free S.-Middle
Niaz, Muhammad		M	156.0	52.0	'40 • 7 • 10	"	Free S.-Fly
Abdul, Aziz	502	M	.	.		Shooting Tir	Small Bore-3 P.

NAME NOM	NO. NO.	SEX SEXE	HEIGHT HAUTEUR	WEIGHT POIDS	DATE OF BIRTH DATE DE NAISSANCE	EVENT EPREUVE
Chaudhry, Saifi	327	M	.	.		Shooting Tir
Abdur, Rashid	259	M	.	.		Small Bore-3 P. Rapid Fire Pistol
Chaudhry, Aziz Ahmed	257	M	160.0	60.0	'32 • 1 • 1	"
Khawja, Mohiuddin	46	M	175.3	81.0	'29 • 7 • 15	"
Salaum, M. A.	258	M	162.5	58.0	'24 • 8 • 20	"
PANAMA PANAMA						
Daniel, Marcella	153	F	157.0	52.0	'43 • 8 • 10	Athletics Athlétisme
Dunn, Lorraine	156	F	164.0	58.0	'42 • 9 • 12	"
Mitchell, Jean	155	F	165.0	51.0	'40 • 11 • 7	"
Oakley, Delceita Lucia	154	F	160.0	52.0	'44 • 4 • 22	"
Subers, Josefina	157	F	157.0	52.0	'44 • 10 • 21	"
Frazer, Alfonso	207	M	160.0	57.0	'47 • 1 • 4	Boxing Boxe
Torres, Saul	188	M	156.0	63.0	'37 • 7 • 19	Fencing Escrime
Tovar Jovane, Luis M.	189	M	171.0	77.0	'05 • 2 • 3	"
Worthington, Marlene A.	187	F	159.0	53.0	'37 • 5 • 26	"
Lee, Ildefonso	38	M	165.0	60.0	'36 • 3 • 12	Weight-Lifting Haltérophilie
Chu Yi, Aurelio		M	165.0	62.1	'29 • 1 • 31	Judo
Campbell, Eduardo		M	161.0	55.0	'23 • 7 • 2	Wrestling Lutte
Cohen Cattan, Sion E.		M	180.0	93.0	'34 • 11 • 30	"
Gonzalez, Alfonso Rafael		M	180.0	87.0	'45 • 10 • 3	"
PERU PEROU						
Abugattas, Roberto	485	M	181.0	79.0	'43 • 1 • 17	Athletics Athlétisme
Cavero, Jose	484	M	168.0	71.0	'40 • 8 • 16	"
Di Tolla, Gerardo	483	M	171.0	66.0	'43 • 1 • 13	"
Benalcazar, Oscar	8	M	189.0	92.0	'42 • 11 • 2	Basket-Ball
Duarte, Enrique	4	M	190.0	88.0	'38 • 5 • 26	"
Duarte, Luis	6	M	197.0	88.0	'41 • 4 • 10	"
Duarte, Raul	14	M	206.0	89.0	'44 • 11 • 11	"
Duarte, Ricardo	5	M	202.0	91.0	'40 • 2 • 9	"
Guzman, Jose	12	M	190.0	75.0	'37 • 5 • 10	"
Paredes, Simon	9	M	180.0	82.0	'45 • 12 • 24	"
Sangio, Tomas	11	M	195.0	80.0	'42 • 5 • 25	"
Sevilla, Oscar	10	M	188.0	76.0	'42 • 10 • 14	"
Valerio, Manuel	15	M	180.0	88.0	'43 • 1 • 1	"
Vargas, Jorge	7	M	182.0	85.0	'42 • 7 • 4	"
Vasquez, Carlos	13	M	200.0	105.0	'42 • 7 • 8	"
Toda Nishimura, Teofilo	115	M	165.0	60.0	'35 • 6 • 18	Cycling Cyclisme
Canepa Bustamante, Carlos		M	175.0	75.0	'43 • 3 • 7	Swimming and Diving Natation et Plongeurs
Ferrero Costa, Augusto		M	184.0	72.0	'44 • 2 • 3	"
Ledgard Buse, Walter		M	182.0	76.0	'45 • 1 • 3	"
Ocampo, Gustavo		M	168.0	65.0	'47 • 6 • 26	"
Paz Soldan, Luis		M	187.0	82.0	'45 • 8 • 31	"
Vivanco Roca, Rosario		F	162.0	54.0	'49 • 7 • 3	"
Caceres Lopez, Javier	234	M	160.0	61.0	'25 • 4 • 19	Shooting Tir
Caceres Lopez, Oscar	232	M	171.0	67.0	'32 • 6 • 22	"
Cornejo Calderon, G.	230	M	175.0	78.0	'19 • 6 • 25	"
De Atzel Guilay, Edward	51	M	170.0	82.0	'17 • 3 • 11	"
Dibos Cauvi, Enrique	3	M	172.0	85.0	'32 • 9 • 25	"
Lastarria Escobedo, C.	233	M	174.0	110.0	'17 • 8 • 27	"
Malpartida, L. T. Armando	238	M	172.0	90.0	'28 • 2 • 22	"
Puente Salvatierra, Pedro	235	M	162.0	74.0	'07 • 5 • 13	"
Vita Segura, Antonio	236	M	168.0	70.0	'21 • 12 • 16	"
PHILIPPINES PHILIPPINS						
Barcenas, Loretta A.	159	F	158.0	48.1	'42 • 12 • 19	Athletics Athlétisme
Canete, Mildred K.	160	F	167.0	50.8	'46 • 7 • 31	"
De La Vina, Josephine H.	164	F	183.0	82.1	'46 • 4 • 15	"
Ebreo, Miguel I.	490	M	175.0	56.8	'39 • 11 • 21	"
Jazmin, Arsenio L.	488	M	180.0	68.2	'35 • 5 • 25	"
Lagrosas, Lolita R.	163	F	164.0	50.8	'38 • 8 • 24	"

NAME NOM	NO. NO.	SEX SEXE	HEIGHT HAUTEUR	WEIGHT POIDS	DATE OF BIRTH DATE DE NAISSANCE	EVENT EPREUVE	
Molinos, Aida O.	161	F	157.0	48.6	'41 • 9 • 14	Athletics Athlétisme	4X100m
Onofre, Rogelio P.	486	M	172.0	67.0	'38 • 12 • 12	"	100m, 200m, 4X100m
Pellosis, Claro A.	489	M	162.0	53.0	'34 • 11 • 28	"	4X100m
Restar, Nelly R.	162	F	158.0	46.4	'39 • 12 • 16	"	4X100m
Sulaiman, Mona	158	F	170.0	63.6	'44 • 7 • 9	"	100m, 200m, 4X100m
Valles, Arnulfo V.	487	M	175.0	66.0	'40 • 8 • 15	"	100m, 4X100m
Alipala, Manfredo P.	212	M	173.0	66.5	'38 • 10 • 25	Boxing Boxe	Welter
Arpon, Rodolfo	211	M	168.0	56.0	'44 • 4 • 10	"	Light
Calumarde, Dominador S.	208	M	160.0	50.0	'46 • 12 • 23	"	Fly
Ocampo, Felix O.	213	M	173.0	70.0	'41 • 1 • 8	"	L. Middle
Torrevillas, Arnulfo	209	M	160.0	54.0	'39 • 8 • 15	"	Bantam
Villanueva, Anthony N.	210	M	165.0	56.5	'45 • 3 • 18	"	Feather
Arceo, Norberto J.	127	M	170.0	54.0	'43 • 8 • 28	Cycling Cyclisme	Team Pursuit, Road Ind., Team T. T.
Olivares, Daniel A.	128	M	165.0	57.3	'40 • 7 • 2	"	Team Pursuit, Road Ind., Team T. T.
Padilla, Cornelio A.	129	M	165.0	51.0	'46 • 11 • 18	"	Team Pursuit, Road Ind., Team T. T.
Romeo, Arturo M.	130	M	168.0	57.0	'41 • 10 • 20	"	Team Pursuit, Road Ind., Team T. T.
Floro, Maria Luisa G.	115	F	152.5	46.8	'44 • 6 • 7	Gymnastics Gymnastique	
Magluyan, Evelyn G.	114	F	152.5	43.7	'44 • 9 • 5	"	
Pastrana, Demetrio T.	94	M	152.5	49.0	'41 • 4 • 9	"	
Payao, Fortunato O.	95	M	160.0	60.0	'40 • 3 • 3	"	
Rocamora, Artemio E.	109	M	170.0	80.0	'34 • 6 • 29	Weight-Lifting Haltérophilie	L. Heavy
Garcia, Narzal L.		M	173.0	72.7	'46 • 7 • 13	Judo	Middle Weight
Ong, Thomas Chi Hong		M	173.0	72.0	'38 • 3 • 8	"	All Weights
Repuyan, Bernardino R.		M	170.0	72.7	'28 • 4 • 2	"	Middle Weight
Uematsu, Vicente H.		M	160.0	52.2	'38 • 3 • 30	"	Light
Garcia, Fernando H.		M	185.4	87.0	'35 • 4 • 18	Wrestling Lutte	Free S., Greco R.-Middle
Mayo, Job Jr.		M	173.0	76.0	'41 • 10 • 19	"	Free S., Greco R.-Welter
Senosa, Antonio T.		M	166.0	63.0	'35 • 11 • 18	"	Free S., Greco R.-Feather
Tumasis, Tortillano T.		M	164.0	57.0	'34 • 7 • 27	"	Free S., Greco R.-Bantam
Jalma-Ani, Amman E.		M	170.0	60.0	'48 • 12 • 15	Swimming and Diving Natation et Plongeurs	200m Breast
Landrito, Rolando M.		M	165.0	59.0	'45 • 9 • 23	"	200m Breast
Ang Leopeldo B	240	M	180.0	56.8	'37 • 12 • 19	Shooting Tir	Free Rifle
Bond, Edgar Jr. V.	244	M	164.0	74.5	'35 • 11 • 25	"	Free Pistol
Feliciano, Adolfo S.	501	M	173.0	72.0	'30 • 6 • 22	"	Free Rifle
Gison, Martin M.	241	M	173.0	61.3	'14 • 3 • 14	"	Small Bore-3 P., Prone
Miranda, Horacio R.	247	M	165.0	65.9	'31 • 9 • 20	"	Small Bore-3 P.
Miranda, Paterno, Jr. R.	246	M	168.0	67.7	'30 • 7 • 24	"	Rapid Fire Pistol
Ninonuevo, Mariano S.	245	M	168.0	64.0	'21 • 8 • 15	"	Free Pistol
Quitoriano, Raymundo R.		M	168.0	72.6	'33 • 2 • 28	"	Small Bore-3 P.
Salandanán, Pacifico Y.	243	M	164.0	52.0	'29 • 9 • 22	"	Small Bore-Prone
San Juan, Bernardo F.	239	M	168.0	61.4	'24 • 3 • 12	"	Free Rifle
Villafuerte, Jaime F.	503	M	162.0	60.0	'20 • 8 • 26	"	Small Bore-Prone
Abaya, Antonio		M	.	.	'36 • 3 • 11	Yachting	Reserve
Davis, Roger		M	.	.	'35 • 10 • 17	"	Reserve
Juntereal, Feliciano		M	.	.	'34 • 1 • 20	"	Dragon
Lim, Bienvenido		M	177.8	63.6	'31 • 12 • 23	"	Reserve
Preysler, Fausto		M	.	.	'14 • 2 • 14	"	Dragon
Villarreal, Jesus		M	.	.	'28 • 11 • 2	"	Dragon
POLAND POLOGNE							
Badenski, Andrzej	495	M	174.0	63.0	'43 • 5 • 10	Athletics Athlétisme	200m, 400m, 4X400m
Baran, Witold	499	M	178.0	70.0	'39 • 7 • 29	"	1500m
Begier, Zenon	513	M	200.0	95.0	'35 • 11 • 23	"	Discus Throw
Bieda, Jaroslawa	171	F	167.0	62.0	'37 • 1 • 20	"	High Jump
Boguszewicz, Lech	500	M	174.0	66.0	'38 • 8 • 27	"	5000m
Ciepla, Teresa Barbara	169	F	166.0	60.0	'38 • 10 • 19	"	800m Hurdles, 4X100m
Cieply, Olgierd	518	M	184.0	98.0	'36 • 3 • 28	"	Hammer Throw
Czernik, Edward	505	M	180.0	82.0	'40 • 9 • 25	"	High Jump
Dudziak, Marian	492	M	183.0	80.0	'41 • 2 • 2	"	100m, 4X100m
Filipiuk, Marian	503	M	178.0	70.0	'41 • 2 • 2	"	4X100m, 4X400m

NAME NOM	NO. NO.	SEX SEXE	HEIGHT HAUTEUR	WEIGHT POIDS	DATE OF BIRTH DATE DE NAISSANCE	EVENT EPREUVE	
Foik, Marian	496	M	172.0	69.0	'33 • 10 • 6	Athletics Athlétisme	200m, 4X100m
Gierajewski, Boguslaw	501	M	177.0	80.0	'37 • 6 • 4	"	400m, 4X400m
Gorecka, Halina	165	F	168.0	57.0	'38 • 2 • 4	"	100m, 200m, 4X100m
Jaskolski, Jan	509	M	180.0	68.0	'39 • 10 • 28	"	Triple Jump
Kirszenstein, Irena	168	F	176.0	60.0	'46 • 5 • 24	"	200m, 4X100m, Long Jump
Klobukowska, Ewa	166	F	170.0	60.0	'46 • 10 • 1	"	100m, 4X100m
Kluczek, Ireneusz	498	M	177.0	68.0	'40 • 5 • 5	"	400m, 4X400m
Komar, Wladyslaw	512	M	195.0	105.0	'40 • 4 • 11	"	Shot Put
Liponski, Wojciech	504	M	177.0	69.0	'42 • 12 • 16	"	4X400m
Maniak, Wieslaw Jan	493	M	171.0	74.0	'38 • 5 • 22	"	100m, 4X100m
Nikiciuk, Wladyslaw	515	M	180.0	87.0	'40 • 3 • 9	"	Javelin Throw
Piatkowska, Maria	170	F	164.0	60.0	'31 • 2 • 24	"	80m Hurdles, 4X100m
Piatkowski, Edmund	510	M	183.0	95.0	'36 • 1 • 31	"	Shot Put, Discus Throw
Rut, Tadeusz	516	M	184.0	98.0	'31 • 10 • 11	"	Hammer Throw
Rutyna, Mieczyslaw	519	M	185.0	72.5	'31 • 5 • 29	"	20km, 50km Road Walk
Sidlo, Janusz	514	M	182.0	87.0	'33 • 6 • 19	"	Javelin Throw
Smolinski, Zdzislaw	517	M	179.0	94.0	'42 • 12 • 7	"	Hammer Throw
Sobotta, Barbara	167	F	163.0	59.0	'36 • 12 • 4	"	100m, 200m, 4X100m
Sokolowski, Wlodzimierz	506	M	184.0	73.0	'40 • 9 • 3	"	Pole Vault
Sosgornik, Alfred	511	M	190.0	120.0	'33 • 8 • 16	"	Shot Put
Stalmach, Andrzej	507	M	185.0	76.0	'42 • 5 • 1	"	Long Jump
Swatowski, Stanislaw	497	M	177.0	74.0	'34 • 3 • 25	"	400, 4X400 m
Syka, Zbigniew	491	M	175.0	69.5	'36 • 3 • 24	"	100m, 4X100m
Szklarczyk, Edward Igancy	502	M	167.0	53.0	'41 • 7 • 31	"	3000m S. C.
Szmidt, Jozef	508	M	183.0	76.0	'35 • 3 • 28	"	Triple Jump
Zielinski, Andrzej	494	M	173.0	70.0	'36 • 8 • 20	"	200m, 4X100m
Grajczyk, Szczepan		M	176.0	81.0	'31 • 12 • 11	Rowing Aviron	Four, With Cox
Kozera, Stanislaw		M	164.0	52.0	'43 • 1 • 27	"	Pair, With Cox
Kubiak, Eugeniusz		M	186.0	81.0	'39 • 5 • 25	"	Single Sculls
Leszczynski, Marian		M	184.0	84.0	'36 • 12 • 8	"	Four, With Cox
Lubicki, Ryszard		M	180.0	85.0	'36 • 9 • 3	"	Four, With Cox
Naskrecki, Kazimierz		M	186.0	85.0	'38 • 3 • 4	"	Pair, With Cox
Nawrot, Czeslaw		M	188.0	84.0	'42 • 3 • 11	"	Pair, Without Cox
Nowaczyk, Andrzej		M	181.0	80.0	'39 • 3 • 3	"	Four, With Cox
Pawlowski, Jerzy		M	159.0	50.0	'35 • 8 • 24	"	Four, With Cox
Siejkowski, Marian		M	196.0	94.0	'40 • 8 • 29	"	Pair, With Cox
Slusarski, Alfons		M	188.0	81.0	'42 • 1 • 23	"	Pair, Without Cox
Szypula, Mieczyslaw		M	188.0	87.0	'38 • 9 • 18	"	Reserve, Oarsmen
Blauth, Tadeusz Michal	6	M	204.0	84.0	'39 • 7 • 1	Basket-Ball	
Czernichowski. K.J.	14	M	192.0	80.0	'38 • 2 • 6	"	
Dregier, Zbigniew	15	M	180.0	75.0	'35 • 7 • 17	"	
Frelkiewicz, Kazimierz	13	M	181.0	74.0	'40 • 2 • 20	"	
Likszo, Bohdan Stanislaw	11	M	196.0	106.0	'40 • 1 • 1	"	
Lopatka, Mieczyslaw	12	M	196.0	96.0	'39 • 10 • 10	"	
Olejniczak, Stanislaw	8	M	193.0	87.0	'38 • 3 • 28	"	
Perka, Andrzej Mieczyslaw	7	M	186.0	83.0	'41 • 6 • 16	"	
Piskun, Jerzy-Andrzej	10	M	198.0	81.0	'38 • 6 • 4	"	
Pstrokonski Andrzej S.	5	M	186.0	86.0	'36 • 6 • 28	"	
Sitkowski, Krzysztof M.	9	M	180.0	73.0	'35 • 11 • 21	"	
Wichowski, Janusz Wiktor	4	M	196.0	88.0	'35 • 10 • 6	"	
Bendig, Brunon	215	M	168.0	54.0	'38 • 10 • 6	Boxing Boxe	Bantam
Grudzien, Jozef	217	M	168.0	60.0	'39 • 4 • 1	"	Light
Grzesiak, Jozef	220	M	181.0	71.0	'41 • 2 • 18	"	L. Middle
Gutman, Piotr	216	M	163.0	57.0	'41 • 6 • 30	"	Feather
Jedrzejewski, Wladyslaw	223	M	188.0	94.0	'35 • 4 • 23	"	Heavy
Kasprzyk Marian	219	M	168.0	67.0	'39 • 9 • 22	"	Welter
Kulej, Jerzy	218	M	167.0	63.0	'40 • 10 • 19	"	L. Welter
Olech, Artur	214	M	160.0	51.0	'40 • 6 • 22	"	Fly
Pietrzykowski, Zbigniew	222	M	183.0	81.0	'34 • 10 • 14	"	L. Heavy

NAME NOM	NO. NO.	SEX SEXE	HEIGHT HAUTEUR	WEIGHT POIDS	DATE OF BIRTH DATE DE NAISSANCE	EVENT EPREUVE	
Walasek, Tadeusz	221	M	176.0	74.5	'36 • 7 • 15	Boxing	Middle
Antonowicz Izabella	103	F	160.0	59.0	'42 • 3 • 16	Canoeing Canotage	Kayak 2
Doering, Jadwiga	104	F	158.0	57.0	'38 • 11 • 2	"	Kayak 2
Jankowiak, Stanislaw	105	M	181.0	81.0	'41 • 5 • 8	"	Kayak 4
Kaplaniak, Stefan	106	M	176.0	72.0	'33 • 4 • 16	"	Kayak 2
Marchlik, Ryszard	107	M	178.0	78.0	'39 • 11 • 3	"	Kayak 4
Pilecka, Daniela	108	F	160.0	61.0	'35 • 5 • 24	"	Kayak 1
Piszcz, Rafal Maciej	109	M	179.0	80.0	'40 • 10 • 14	"	Kayak 4
Ruszkowski, Robert A.	110	M	188.0	30.0	'42 • 6 • 9	"	Kayak 4
Szuskiewicz, Wladyslaw	111	M	175.0	75.0	'38 • 11 • 12	"	Kayak 1
Zielinski, Wladyslaw	112	M	179.0	76.0	'35 • 7 • 24	"	Kayak 2
Beker, Jozef	121	M	179.0	71.0	'37 • 3 • 28	Cycling Cyclisme	Road Ind., Team T. T.
Blawdzin, Andrzej	120	M	174.0	62.0	'38 • 8 • 19	"	Road Ind., Team T. T.
Jozefowicz, Lucjan	133	M	175.0	69.0	'35 • 6 • 30	"	Ind. Pursuit
Kudra, Jan	134	M	174.0	68.0	'37 • 7 • 5	"	Reserve
Latocha, Wacław	131	M	174.0	68.0	'36 • 10 • 25	"	1000m T. T.
Magiera, Jan	122	M	178.0	71.0	'38 • 9 • 30	"	Road Ind., Team T. T.
Zajac, Zbyslaw	132	M	170.0	65.0	'33 • 9 • 9	"	Scratch Sprint
Zielinski, Rajmund	123	M	179.0	77.0	'40 • 11 • 9	"	Road Ind., Team T. T.
Andrzejewski Bohdan	197	M	185.0	76.0	'42 • 1 • 15	Fencing Escrime	Epee Ind., Team
Franke, Egon	190	M	176.0	68.0	'35 • 10 • 23	"	Foil Ind., Team, Sabre Team
Glos, Wieslaw	199	M	185.0	76.0	'36 • 9 • 12	"	Epee Ind., Team
Gonsior, Bogdan	196	M	195.0	80.0	'37 • 2 • 16	"	Epee Ind., Team
Nielaba, Henryk	195	M	175.0	68.0	'33 • 9 • 5	"	Epee Ind., Team, Foil Team
Ochyra, Emil	200	M	173.0	64.0	'36 • 7 • 12	"	Sabre Ind., Team
Parulski, Ryszard	191	M	185.0	82.0	'38 • 3 • 9	"	Foil Ind., Team, Epee Team
Pawlowski, Jerzy	201	M	174.0	74.0	'32 • 10 • 25	"	Sabre Ind., Team
Piatkowski, Andrzej	202	M	168.0	70.0	'34 • 10 • 22	"	Sabre Ind., Team
Pomarnacki, Mikołaj	198	M	172.0	75.0	'34 • 9 • 19	"	Epee Team
Rozyckij Janusz	192	M	170.0	75.0	'39 • 5 • 10	"	Foil Team
Skrudlik Zbigniew	193	M	178.0	73.0	'34 • 5 • 12	"	Foil Ind., Team
Woyda, Witold	194	M	168.0	63.0	'39 • 5 • 10	"	Foil Ind., Team
Zablocki, Wojciech	203	M	165.0	60.0	'30 • 12 • 6	"	Sabre Ind., Epee Team
Zub, Ryszard	204	M	174.0	73.0	'34 • 3 • 24	"	Sabre Team
Apostolska, Elzbieta	161	F	158.0	57.0	'44 • 3 • 28	Gymnastics Gymnastique	
Balska, Brygida	167	F	163.0	54.0	'39 • 2 • 11	"	
Brylka, Gerda	165	F	159.0	56.0	'41 • 8 • 12	"	
Eustachiewicz, Barbara	164	F	159.0	57.0	'38 • 11 • 5	"	
Hawelek, Ernest	87	M	170.0	67.0	'35 • 11 • 28	"	
Jankowicz, Jan	81	M	163.0	68.0	'32 • 12 • 9	"	
Konopka, Andrzej	82	M	173.0	67.0	'43 • 9 • 1	"	
Kubica, Mikołaj	85	M	168.0	60.0	'45 • 10 • 27	"	
Kubica, Wilhelm	86	M	167.0	60.0	'43 • 12 • 24	"	
Kucharczyk Alfred	83	F	170.0	69.0	'37 • 11 • 2	"	
Miler, Dorota	162	F	165.0	61.0	'44 • 2 • 1	"	
Niedurna, Gizela	163	M	153.0	46.0	'39 • 1 • 31	"	
Rokosa, Aleksander	84	F	175.0	69.0	'36 • 7 • 17	"	
Wilczek, Malgorzata	166	M	161.0	62.0	'44 • 3 • 9	"	
Baszanowski, Waldemar	73	M	165.0	67.0	'35 • 8 • 15	Weight-Lifting Halterophilie	Light
Kaczkowski, Jerzy	122	M	183.0	82.0	'38 • 5 • 16	"	L. Heavy
Kozłowski, Rudolf	49	M	156.0	60.0	'35 • 7 • 15	"	Feather
Nowak, Mieczyslaw	50	M	160.0	61.0	'36 • 12 • 22	"	Feather
Palinski, Ireneusz	132	M	173.0	89.0	'32 • 5 • 13	"	M. Heavy
Trebicki, Henryk	25	M	158.0	55.5	'40 • 10 • 22	"	Bantam
Zielinski, Marian	74	M	160.0	67.0	'29 • 11 • 24	"	Light
Dubicki, Boleslaw		M	165.0	76.0	'34 • 9 • 16	Wrestling Lutte	Greco R.-Welter
Knitter, Bernard		M	164.0	57.0	'38 • 2 • 28	"	Greco R.-Bantam
Kwiecinski, Czeslaw		M	179.0	86.0	'43 • 1 • 20	"	Greco R.-Middle
Macioch, Kazimierz		M	167.0	63.0	'32 • 6 • 1	"	Greco R.-Feather

NAME NOM	NO. NO.	SEX SEXE	HEIGHT HAUTEUR	WEIGHT POIDS	DATE OF BIRTH DATE DE NAISSANCE	EVENT EPREUVE	
Sosnowski, Lucjan		M	182.0	97.0	'33 • 1 • 6	Wrestling Lutte	Greco R.-L. Heavy
Gorski, Henryk	248	M	174.0	70.0	'38 • 4 • 4	Shooting Tir	Free Rifle, Small Bore-3 P.
Kurzawski, Kazimierz	251	M	182.0	80.0	'42 • 10 • 20	"	Free Pistol
Marucha, Stanislaw	250	M	166.0	67.0	'37 • 1 • 17	"	Small Bore-Prone
Nowicki, Jerzy	249	M	164.0	64.0	'33 • 1 • 2	"	Free Rifle, Small Bore-3 P., Prone
Smelczynski, Adam	14	M	180.0	74.0	'20 • 9 • 14	"	Clay Pigeon
Zapedzki, Jozef	252	M	174.0	73.0	'29 • 3 • 11	"	Rapid Fire Pistol
Busz, Hanna Krystyna	11	F	181.0	73.0	'40 • 11 • 23	Volley-Ball	
Czajkowska, Krystyna M	1	F	172.0	63.0	'36 • 4 • 25	"	
Golimowska, Maria	3	F	166.0	61.0	'32 • 8 • 20	"	
Hermel, Barbara Wieslawa	12	F	174.0	67.0	'43 • 11 • 13	"	
Jakubowska, Krystyna	6	F	178.0	68.0	'42 • 12 • 15	"	
Kordaczuk, Danuta	5	F	166.0	64.0	'39 • 9 • 2	"	
Krupa, Krystyna	10	F	177.0	72.0	'39 • 1 • 15	"	
Ledwig, Jozefa	2	F	172.0	69.0	'35 • 4 • 18	"	
Marko, Jadwiga	7	F	178.0	71.0	'39 • 4 • 6	"	
Rutkowska, Jadwiga M.	4	F	173.0	72.0	'34 • 2 • 2	"	
Sliwka, Maria	8	F	168.0	67.0	'35 • 12 • 7	"	
Szczesniewska, Zofia A.	9	F	172.0	68.0	'43 • 8 • 31	"	
PORTUGAL PORTUGAL							
Aldegalega, A. R.	522	M	161.0	52.0	'37 • 11 • 23	Athletics Athlétisme	10000m, Marathon
Oliveira, M. F.	521	M	171.0	59.0	'40 • 10 • 20	"	3000m S. C., 1500m, 5000m
Rocha, Jose Fernandes Da	520	M	172.0	64.0	'35 • 8 • 15	"	100m, 200m
Fonseca, Esbela F. R. D.	184	F	155.0	54.0	'42 • 7 • 26	Gymnastics Gymnastique	
Matos, Fernando Costa		M	173.0	77.0	'41 • 4 • 1	Judo	Middle Weight
Basto, Antonio A. B.		M	172.0	73.0	'45 • 11 • 9	Swimming and Diving Natation et Plongeon	400m Ind. Medley
Fonseca, Vitor Manuel F. D.		M	165.0	69.0	'46 • 4 • 3	"	200m Butterfly
Ribeiro, Herlander Felga		M	182.0	80.0	'43 • 5 • 30	"	100m Free
Alves Callado, Henrique		M	.	.	'20 • 6 • 12	Equestrian Sports Sport Equestre	Jumping Grand Prix
Duarte Silva, Joaquim M.		M	.	.	'24 • 3 • 17	"	Jumping Grand Prix
Cayolla, Jose	254	M	.	.	'30 • 10 • 1	Shooting Tir	Rapid Fire Pistol
Costa, Manuel	253	M	.	.	'26 • 6 • 10	"	Small Bore-Prone
Marques, Armando Silva	27	M	.	.	'37 • 5 • 1	"	Clay Pigeon
Valle-Flor, Guy	28	M	.	.	'20 • 5 • 19	"	Clay Pigeon
Carlos, Da Camara R. F.		M	.	.	'31 • 5 • 2	Yachting	Dragon
Duarte, Manuel De A. B.		M	.	.	'21 • 7 • 26	"	Star
Eduardo, Guedes De Q.		M	.	.	'36 • 6 • 29	"	Dragon
Fernando, Pinto C. B.		M	.	.	'24 • 9 • 1	"	Star
Helder, T. Pacheco S. O.		M	.	.	'34 • 8 • 21	"	Finn
Joaquim, Ferreira P. B.		M	.	.	'32 • 12 • 11	"	Dragon
RHODESIA RHODESIE							
Du Preez, Johan	529	M	178.0	75.0	'36 • 7 • 8	Athletics Athlétisme	100m, 200m
Kanda, Mathias	531	M	160.0	61.0	'42 • 6 • 2	"	Marathon
Mrombe, Robson	530	M	168.0	59.0	'41 • 7 • 22	"	Marathon
Gibson, John Thomas	224	M	185.5	48.0	'41 • 5 • 15	Boxing Boxe	L. Middle
Barbour, Roy Hilton	9	M	174.0	61.2	'35 • 6 • 2	Hockey	
Beets, Derrick John	7	M	167.6	65.8	'41 • 9 • 20	"	
Brain, Dereck Hayden	1	M	185.4	80.7	'36 • 7 • 26	"	
Cumming, Graham Charles	15	M	172.7	70.3	'41 • 1 • 15	"	
Faulds, Beverly F.J.	2	M	180.3	69.4	'33 • 5 • 16	"	
Harvey, Edward G.P.	16	M	182.9	89.8	'25 • 8 • 18	"	
Koch, Lloyd Bowen	10	M	174.0	72.6	'31 • 6 • 17	"	
Mackay, Ian Reay	8	M	179.1	71.7	'38 • 5 • 9	"	
Mc Phun, John David	5	M	175.3	63.5	'40 • 9 • 8	"	
Robertson, Robert Gordon	4	M	185.4	74.4	'38 • 3 • 31	"	
Spence, Ronald John	14	M	174.0	70.8	'45 • 7 • 20	"	
Tomlinson, Desmond Neame	13	M	175.3	70.3	'39 • 8 • 4	"	
Turpin, William Homan	6	M	185.4	79.4	'32 • 7 • 28	"	

NAME NOM	NO. NO.	SEX SEXE	HEIGHT HAUTEUR	WEIGHT POIDS	DATE OF BIRTH DATE DE NAISSANCE	EVENT EPREUVE
Ullyett, Robert Bassett	12	M	177.8	76.2	'36 • 4 • 5	Hockey
Unger, Anthony Charles	11	M	179.1	70.3	'38 • 6 • 13	"
Van Blomestein, Kevin A.	3	M	174.0	59.0	'35 • 1 • 16	"
Bezuidenhout, Sarie		F	157.5	57.0	'45 • 2 • 18	Swimming and Diving Natation et Plongeoons
Grant Stuart, Lindsay M.		F	160.0	56.2	'47 • 9 • 28	"
Rossiter, Terry		M	170.0	75.0	'44 • 7 • 2	"
Sidelsky, Marilyn		F	165.0	63.3	'48 • 4 • 29	"
Wood, Jennifer		F	171.5	64.0	'48 • 6 • 24	"
Lamprecht, Johannes	21	M	187.0	90.0	'22 • 8 • 22	Shooting Tir
Rickards, John	22	M	183.0	90.0	'28 • 10 • 12	"
Butler, Alan David		M	183.0	93.0	'27 • 10 • 23	Yachting
Butler, Joanna Campbell		F	165.0	64.0	'23 • 9 • 20	"
Crossley, Anthony James		M	170.0	75.0	'39 • 5 • 3	"
Lincoln, George Albert F.		M	185.0	86.0	'18 • 11 • 14	"
McFadden, Michael		M	183.0	94.0	'36 • 5 • 14	"
RUMANIA ROUMANIE						
Badea, Constantin	534	M	172.0	74.0	'27 • 9 • 26	Athletics Athlétisme
Balas, Iolanda	173	F	184.0	72.0	'36 • 12 • 12	"
Barabas, Andrei	533	M	179.0	65.0	'27 • 12 • 9	"
Baruh, Elias	541	M	172.0	69.0	'21 • 3 • 17	"
Catarama, Olimpia	177	F	166.0	82.0	'40 • 10 • 25	"
Chitoban, Dumitru	538	M	170.0	69.0	'34 • 10 • 20	"
Ciochina, Serban	535	M	178.0	70.0	'39 • 11 • 31	"
Diaconescu, Maria	178	F	167.0	68.0	'37 • 2 • 16	"
Dragan, Emil	542	M	175.0	75.0	'26 • 6 • 27	"
Grecescu, Constantin	539	M	175.0	64.0	'29 • 1 • 7	"
Jurca, Valeriu	532	M	189.0	75.0	'39 • 4 • 8	"
Manoliu, Lia	176	F	179.0	81.0	'32 • 4 • 25	"
Murafa, Nicolae	537	M	178.0	88.0	'21 • 11 • 3	"
Penes, Mihaela	179	F	186.0	94.0	'47 • 7 • 22	"
Popa, Ilie	543	M	172.0	69.0	'40 • 5 • 9	"
Salagean, Ana	175	M	166.0	89.0	'37 • 3 • 27	"
Savescu, Andrei	540	F	174.0	84.0	'26 • 11 • 30	"
Simu, Olivia	172	M	167.0	65.0	'31 • 2 • 1	"
Viscopoleanu, Viorica	174	F	166.0	50.0	'39 • 8 • 8	"
Zimbreşteanu, Gheorghe	536	F	182.0	83.0	'42 • 3 • 18	"
Benedek, Zoltan		M	182.0	86.0	'29 • 7 • 22	Rowing Aviron
Borbely Covacs, Ludovic		M	185.0	84.0	'39 • 2 • 20	"
Paunescu, Oprea		M	169.0	51.0	'36 • 7 • 6	"
Petrov, Ionel		M	185.0	101.0	'34 • 10 • 7	"
Pongracz, Stefan		M	178.0	84.0	'30 • 8 • 17	"
Rieffelt, Gheorghe		M	181.0	84.0	'36 • 1 • 6	"
Tarara, Nichifor		M	173.0	86.0	'36 • 3 • 12	"
Veres, Carol		M	184.0	77.0	'26 • 4 • 12	"
Ciuca, Constantin	225	M	159.0	51.0	'41 • 9 • 21	Boxing Boxe
Crudu, Constantin	227	M	165.0	57.0	'44 • 7 • 27	"
Mariutan, Vasile	233	M	184.0	95.0	'35 • 3 • 8	"
Mihalic, Iosif	228	M	173.0	63.5	'38 • 2 • 13	"
Mirza, Vasile	230	M	177.0	71.0	'34 • 7 • 26	"
Monea, Ion	231	M	179.0	75.0	'40 • 11 • 30	"
Negrea, Gheorghe	232	M	184.0	82.0	'34 • 4 • 21	"
Niculescu, Constantin	229	M	177.0	67.0	'44 • 5 • 26	"
Puiu, Nicolae	226	M	164.0	54.0	'35 • 12 • 4	"
Anastasescu, Mircea	113	M	178.0	76.0	'31 • 3 • 18	Canoeing Canotage
Cuciuc, Simion	114	M	177.0	82.0	'41 • 7 • 4	"
Husarenco, Miron	115	M	186.0	87.0	'38 • 10 • 15	"
Igorov, Andrei	116	M	183.0	87.0	'39 • 12 • 10	"
Ismailciuc, Simion	117	M	167.0	62.0	'30 • 7 • 13	"
Ivanov, Haralambie	118	M	177.0	81.0	'41 • 2 • 22	"

NAME NOM	NO. NO.	SEX SEXE	HEIGHT HAUTEUR	WEIGHT POIDS	DATE OF BIRTH DATE DE NAISSANCE	EVENT EPREUVE
Lauer, Hilde	119	F	160.0	63.0	'43 • 3 • 24	Canoeing Canotage Kayak 1, 2
Lipalit, Elena	120	F	171.0	66.0	'36 • 3 • 22	" Reserve
Lipalit, Igor	121	M	168.0	70.0	'40 • 1 • 14	" Canadian 2
Nicoara, Vasile	122	M	175.0	76.0	'37 • 6 • 13	" Kayak 2
Sciotnic, Atanasie	123	M	178.0	79.0	'42 • 3 • 1	" Kayak 4
Sideri, Cornelia	124	F	168.0	64.0	'38 • 12 • 29	" Kayak 2
Sidorov, Achim	125	M	171.0	73.0	'36 • 8 • 24	" Canadian 2
Turcas, Mihai	126	M	181.0	80.0	'42 • 11 • 18	" Kayak 4
Vernescu, Aurel	127	M	189.0	90.0	'39 • 1 • 23	" Kayak 1, 4
Badara, Gheorghe	125	M	186.0	81.0	'41 • 8 • 16	Cycling Cyclisme Road Ind., Team T. T.
Ciocan, Constantin	116	M	180.0	72.0	'43 • 7 • 28	" Road Team T. T.
Cosma, Ion	126	M	181.0	86.0	'38 • 7 • 11	" Road Ind., Team T. T.
Moiceanu, Gabriel	127	M	176.0	72.0	'38 • 8 • 13	" Ind. Road
Negoita, Dumitru	135	M	169.0	67.0	'34 • 7 • 10	" Ind. Pursuit
Rusu, Emil	128	M	187.0	77.0	'44 • 12 • 26	" Road Team T. T.
Csipler, Attila	213	M	162.0	60.0	'39 • 3 • 17	Fencing Escrime Foil, Sabre Ind., Team
Dersidan, Ana	207	F	164.0	61.5	'44 • 9 • 22	" Foil Ind., Team
Drimba, Ioan	210	M	174.0	64.0	'42 • 3 • 18	" Foil, Sabre Ind., Team
Falb, Iuliu	214	M	176.0	70.0	'42 • 12 • 14	" Foil, Sabre Ind., Team
Gyulai, Ileana	208	F	164.0	58.0	'46 • 6 • 12	" Foil Ind., Team
Haukler, Stefan	212	M	179.0	71.0	'42 • 3 • 9	" Foil Ind., Epee Ind., Team
Jensik, Ecaterina	209	F	162.0	52.0	'46 • 7 • 31	" Foil Ind., Team
Marinescu, Ion	216	M	.	.	'26 • 6 • 16	" Foil Ind.
Muresan, Tanase	211	M	180.0	67.0	'40 • 5 • 22	" Foil Ind., Sabre Ind., Team
Nicu, Alexe	215	M	165.0	70.0	'27 • 11 • 27	" Epee Ind.
Szabo, Olga	205	F	160.0	56.5	'38 • 10 • 9	" Foil Ind., Team
Vicol, Maria	206	F	165.0	59.0	'35 • 10 • 17	" Foil Ind., Team
Vintila, Octavian	217	M	170.0	68.0	'38 • 6 • 22	" Sabre Ind., Team
Adamache, Sterica	20	M	179.0	75.0	'43 • 10 • 17	Football
Andrei, Marin	12	M	178.0	76.0	'40 • 10 • 22	"
Avram, Sorin	7	M	169.0	68.0	'44 • 10 • 24	"
Coe, Dan	6	M	184.0	86.0	'41 • 9 • 8	"
Constantin, Gheorghe	8	M	182.0	80.0	'32 • 12 • 14	"
Creiniceanu, Carol	11	M	169.0	67.0	'39 • 2 • 1	"
Datcu, Ilie	1	M	176.0	70.0	'37 • 7 • 20	"
Dumitriu, Emil	18	M	168.0	66.0	'44 • 10 • 6	"
Georgescu, Niculae	16	M	176.0	73.0	'36 • 1 • 1	"
Greavu, Ilie	2	M	165.0	68.0	'37 • 7 • 19	"
Halmageanu, Bujor	4	M	180.0	79.0	'41 • 2 • 14	"
Ionescu, Ion	9	M	167.0	68.0	'38 • 4 • 5	"
Ivan, Dumitru	14	M	180.0	72.0	'38 • 5 • 14	"
Jenei, Emeric	5	M	168.0	67.0	'37 • 3 • 22	"
Koszka, Constantin	10	M	180.0	81.0	'39 • 9 • 17	"
Nunweiller, Ion	3	M	179.0	78.0	'36 • 1 • 9	"
Pavlovici, Cornel	19	M	182.0	79.0	'42 • 4 • 2	"
Petescu, Mircea	13	M	181.0	74.0	'43 • 10 • 15	"
Petru, Emil	15	M	178.0	76.0	'39 • 9 • 28	"
Pircalab, Ion	17	M	173.0	67.0	'41 • 11 • 15	"
Bajzat, Rozalia	177	F	156.0	51.0	'47 • 4 • 2	Gymnastics Gymnastique Reserve
Ceampelea, Elena	175	F	159.0	53.0	'47 • 2 • 3	"
Condovici, Gheorghe	225	M	174.0	66.0	'41 • 7 • 30	"
Dobosan, Cristina	176	F	164.0	53.0	'43 • 5 • 25	"
Gheorghiu, Costache	227	M	174.0	65.0	'34 • 6 • 18	" Reserve
Ionescu, Atanasia	174	F	153.0	48.0	'35 • 3 • 19	"
Iovan, Sonia	171	F	150.0	49.0	'35 • 9 • 29	"
Kadar, Anton	222	M	168.0	68.0	'41 • 1 • 18	"
Lita, Emilia	173	F	157.0	50.0	'38 • 10 • 20	"
Miclaus, Petre	224	M	157.0	55.0	'39 • 6 • 10	"
Orendi, Frederic	221	M	170.0	66.0	'30 • 3 • 12	"

NAME NOM	NO. NO.	SEX SEXE	HEIGHT HAUTEUR	WEIGHT POIDS	DATE OF BIRTH DATE DE NAISSANCE	EVENT EPREUVE
Popescu, Elena	172	F	161.0	60.0	'35 • 7 • 4	Gymnastics Gymnastique
Szilagyi, Sandor A.	223	M	168.0	65.0	'42 • 2 • 8	"
Tohaneanu, Gheorghe	226	M	172.0	68.0	'36 • 6 • 1	"
Baroga, Lazar	140	M	178.0	90.0	'37 • 8 • 11	Weight-Lifting Halterophilie
Fitz, Balas	52	M	158.0	60.0	'44 • 1 • 2	"
Ioana, Constantin	13	M	168.0	58.0	'26 • 10 • 25	"
Ballo, Francisc		M	181.0	97.0	'32 • 10 • 22	Wrestling Lutte
Bolocan, Marin		M	172.0	63.0	'37 • 8 • 9	"
Bularca, Valeriu		M	176.0	70.0	'31 • 2 • 14	"
Cernea, Ion		M	164.0	57.0	'35 • 10 • 21	"
Martinescu, Nicolae		M	183.0	97.0	'40 • 2 • 24	"
Pirvulescu, Dumitru		M	160.0	52.0	'33 • 6 • 14	"
Popovici, Gheorghe		M	190.0	87.0	'35 • 5 • 4	"
Stingu, Stefan		M	186.0	99.0	'41 • 5 • 19	"
Tampa, Stefan		M	173.0	78.0	'43 • 3 • 16	"
Tapalaga, Gheorghe		M	157.0	52.0	'41 • 2 • 11	"
Taranu, Ion		M	178.0	78.0	'38 • 3 • 14	"
Bratu, Neagu	264	M	173.0	70.0	'35 • 4 • 4	Shooting Tir
Cogut, Traian	262	M	170.0	71.0	'48 • 5 • 7	"
Dumitrescu, Ion	1	M	180.0	99.0	'25 • 7 • 18	"
Enache, Gheorghe	2	M	171.0	71.0	'34 • 9 • 22	"
Maghiar, Gavril	263	M	162.0	78.0	'26 • 12 • 10	"
Olarescu, Ion	260	M	178.0	78.0	'43 • 6 • 11	"
Rosca, Marcel	266	M	180.0	75.0	'43 • 10 • 18	"
Rotaru, Nicolae	261	M	177.0	67.0	'35 • 7 • 16	"
Sirbuj, Iosif	500	M	180.0	80.0	'25 • 9 • 21	"
Tripisa, Ion	265	M	174.0	75.0	'34 • 3 • 30	"
Barbuta, Nicolae	8	M	187.0	87.0	'37 • 5 • 4	Volley-Ball
Chezan C, Alexandrina	9	F	171.0	62.0	'39 • 4 • 29	"
Chezan, Mihai	10	M	185.0	79.0	'35 • 10 • 21	"
Colceru, Sonia	7	F	160.0	57.0	'34 • 1 • 1	"
Coste, Mihai	12	M	186.0	81.0	'38 • 12 • 9	"
Derzsi, Eduard	9	M	193.0	89.0	'34 • 10 • 27	"
Dragan, Aurel	3	M	180.0	76.0	'38 • 6 • 2	"
Enculescu, Ileana	10	F	174.0	65.0	'44 • 10 • 28	"
Fieraru, Gheorghe	1	M	178.0	65.0	'36 • 8 • 24	"
Ganciu, Constantin	11	M	186.0	90.0	'38 • 7 • 17	"
Golosie, Elisabeta	11	F	171.0	72.0	'36 • 6 • 20	"
Grigorovici, Mihai	6	M	188.0	81.0	'37 • 12 • 26	"
Ivanescu, Doina	5	F	172.0	71.0	'35 • 1 • 22	"
Lazeanu, Cornelia	3	F	167.0	62.0	'43 • 6 • 22	"
Mocan, Ana	1	F	165.0	60.0	'37 • 3 • 16	"
Nicolau, Horatiu	2	M	187.0	91.0	'33 • 7 • 5	"
Plocon, Davila	7	M	186.0	89.0	'31 • 7 • 28	"
Popescu, Doina Rodica	6	F	167.0	57.0	'38 • 10 • 1	"
Schreiber, William	5	M	188.0	82.0	'42 • 2 • 10	"
Stanca, Marina	12	F	170.0	60.0	'46 • 9 • 27	"
Szocs, Iuliu	4	M	188.0	92.0	'37 • 12 • 23	"
Todorovschi, Natalia	4	F	172.0	61.0	'31 • 10 • 19	"
Vanea, Lia	8	F	177.0	67.0	'38 • 10 • 3	"
Firoiu, Nicolae		M	185.0	85.0	'39 • 3 • 3	Water-Polo
Grintescu, Anatolie		M	189.0	86.0	'39 • 8 • 1	"
Kroner, Stefan		M	181.0	77.0	'39 • 5 • 30	"
Kuliniac, Iosif		M	171.0	77.0	'41 • 8 • 13	"
Lita, Cosma		M	174.0	74.0	'25 • 9 • 9	"
Marculescu, Cornel		M	172.0	74.0	'41 • 7 • 17	"
Muresanu, Emil		M	182.0	78.0	'39 • 9 • 13	"
Novac, Gruia		M	191.0	80.0	'44 • 1 • 24	"
Stefanescu, Mircea		M	181.0	81.0	'36 • 12 • 2	"

NAME NOM	NO. NO.	SEX SEXE	HEIGHT HAUTEUR	WEIGHT POIDS	DATE OF BIRTH DATE DE NAISSANCE	EVENT EPREUVE
Szabo, Alexandru		M	183.0	87.0	'37 • 1 • 20	Water-Polo
Zahan, Aurel		M	181.0	90.0	'38 • 8 • 8	"
SENEGAL SENEGAL						
Daour, Gueye	553	M	184.0	80.0	'42 • 1 • 17	Athletics Athlétisme 4X400m
Dia, Mansour	555	M	191.0	80.0	'40 • 12 • 27	" Triple Jump
Diop, Malick	549	M	181.0	70.0	'42 • 8 • 24	" 4X100m
Doumya, Bassirou	545	M	179.0	67.0	'42 • 5 • 12	" 100m, 4X100m
Gakou, Amadou	547	M	175.0	65.0	'40 • 3 • 25	" 400m, 4X100m
Mane, Malang	550	M	170.0	64.0	'43 • 1 • 3	" 4X100m
Ndiaye, Abdoulaye	544	M	163.0	63.0	'41 • 4 • 28	" 100m, 4X100m
Ndiaye, Mamadou	552	M	182.0	66.0	'39 • 8 • 2	" 4X400m
Ndiaye, Mambaye	551	M	181.0	67.0	'38 • 5 • 11	" 4X400m
Sarr, Mamadou	548	M	185.0	80.0	'38 • 8 • 11	" 400m Hurdles, 4X400m
Sow, Alioune	546	M	175.0	68.0	'36 • 2 • 19	" 200m, 4X100m
Thiaw, Daniel Alexandre	554	M	179.0	66.0	'37 • 4 • 14	" 4X100m
SPAIN ESPAGNE						
Aguilar, Fernando	557	M	178.0	64.0	'38 • 2 • 14	Athletics Athlétisme 5000m, 10000m
Areta, Luis Felipe	561	M	188.0	75.0	'42 • 3 • 28	" Long Jump, Triple Jump
Aritmendi, Francisco	558	M	157.0	53.0	'38 • 9 • 19	" 5000m
Garriga, Luis Maria	559	M	184.0	77.0	'45 • 6 • 14	" High Jump
Rivas, Rogelio	556	M	170.0	65.0	'44 • 8 • 7	" 100m
Sola, Ignacio	560	M	174.0	69.0	'44 • 2 • 1	" Pole Vault
Barrera, Domingo	236	M	165.0	60.0	'43 • 3 • 9	Boxing Boxe Light
Loren, Valentin	235	M	163.0	57.0	'46 • 8 • 26	" Feather
Senin, Agustin	234	M	160.0	54.0	'46 • 9 • 4	" Bantam
Velazquez, Miguel	237	M	170.0	62.0	'44 • 12 • 27	" L. Welter
Diaz, Mariano	134	M	159.0	63.0	'39 • 9 • 17	Cycling Cyclisme Reserve
Garcia, Juan Bautista	129	M	175.0	73.0	'40 • 9 • 7	" Road Ind., Team T. T.
Goyeneche, Jose Ramon	119	M	174.0	74.5	'40 • 10 • 15	" Road Team T. T.
Lasa, Jose Manuel	130	M	174.0	77.0	'39 • 5 • 21	" Road Ind., Team T. T.
Lopez, Jose	133	M	173.0	72.0	'40 • 2 • 21	" Reserve
Marine, Jorge	131	M	175.0	69.0	'41 • 9 • 14	" Ind. Road
Perurena, Domingo	132	M	170.0	70.0	'43 • 12 • 15	" Ind. Road
Santamarina, Luis Pedro	122	M	169.0	64.0	'42 • 6 • 26	" Road Team T. T.
Alvear, Jonas	14	M	176.0	66.5	'41 • 9 • 23	Hockey
Amat, Francisco	9	M	183.0	76.0	'43 • 3 • 21	"
Amat, Jaime	8	M	172.0	65.5	'41 • 9 • 1	"
Amat, Pedro	16	M	181.0	67.0	'40 • 7 • 13	"
Calzado, Juan Angel	4	M	178.0	76.5	'37 • 3 • 16	"
Colomer, Jose	2	M	183.0	92.5	'35 • 6 • 10	"
Del Coso, Carlos	1	M	166.0	62.0	'33 • 4 • 24	"
Dinares, Jose Antonio	5	M	176.0	74.5	'40 • 1 • 5	"
Dualde, Eduardo	10	M	174.0	75.5	'33 • 12 • 1	"
Echevarria, Jaime	17	M	186.0	75.5	'37 • 10 • 31	"
Garcia, Jose Antonio	12	M	173.0	71.0	'33 • 6 • 23	"
Macaya, Ignacio	7	M	181.0	76.5	'33 • 12 • 21	"
Nogues, Antonio	18	M	181.0	67.5	'45 • 4 • 27	"
Solaun, Julio	3	M	180.0	65.5	'42 • 2 • 1	"
Usoz, Luis Maria	13	M	169.0	69.0	'32 • 10 • 19	"
Ventallo, Narciso	6	M	165.0	54.0	'40 • 9 • 17	"
Ventallo, Santiago	15	M	163.0	60.5	'39 • 7 • 25	"
Vidal, Jorge	11	M	170.0	65.0	'43 • 11 • 9	"
Panizo, Jose		M	182.0	92.0	'36 • 10 • 5	Wrestling Lutte Greco R.-L. Heavy
Ballester, Maria		F	168.0	66.0	'47 • 12 • 12	Swimming and Diving Natation et Plongeon 100m Butterfly
Cabrera, Jesus		M	183.0	75.5	'45 • 12 • 6	" 200m Back, 4X100m Medley
Castane, Isabel		F	144.0	57.0	'46 • 6 • 2	" 200m Breast, 400m Ind. Medley
Codina, Antonio		M	180.0	72.0	'43 • 12 • 29	" 4X200m Free
Espinosa, Jose Miguel		M	178.0	75.0	'45 • 10 • 31	" 100m Free, 4X100m Medley
Fortuny, Juan		M	183.0	74.0	'46 • 5 • 12	" 400m Ind. Medley, 4X200m Free

NAME NOM	NO. NO.	SEX SEXE	HEIGHT HAUTEUR	WEIGHT POIDS	DATE OF BIRTH DATE DE NAISSANCE	EVENT EPREUVE
Martinez, Enrique		M	170.0	74.0	'40 • 6 • 27	Swimming and Diving Natation et Plongéons
Padron, Nazario		M	171.0	73.0	'45 • 10 • 16	"
Perez Cospedal, Antonio		M	173.0	68.0	'44 • 10 • 22	"
Pujol, Joaquin		M	176.0	75.0	'46 • 5 • 21	"
Pulido, Rita		F	163.0	57.0	'45 • 4 • 25	"
Torres, Miguel		M	183.0	78.0	'46 • 1 • 24	"
Alvarez De Bohorquez, J.		M	168.0	66.0	'34 • 8 • 30	Equestrian Sports Sport Equestre
Goyoaga, Fernando		M	176.0	75.0	'20 • 5 • 15	"
Martinez De Vallejo, E.		M	180.0	75.0	'30 • 7 • 15	"
Queipo De Llano, A.		M	181.0	75.0	'31 • 8 • 11	"
Alonso, Jose Luis	32	M	170.0	80.0	'27 • 2 • 25	Shooting Tir
Andoin, Jose Manuel	268	M	165.0	76.0	'14 • 4 • 29	"
Bladas, Jaime	31	M	171.0	68.0	'36 • 5 • 11	"
Garcia, Juan	269	M	170.0	72.0	'34 • 4 • 12	"
Medina, Pedro	267	M	179.0	72.0	'41 • 6 • 25	"
Omist, Mariano	270	M	173.0	82.0	'12 • 1 • 3	"
Thomas, Juan	271	M	160.0	69.0	'26 • 12 • 18	"
Bernar, Alvaro		M	167.0	80.0	'33 • 4 • 18	Yachting
Olabarri, Juan		M	171.0	75.0	'36 • 7 • 5	"
SWEDEN SUEDE						
Asplund, Karl Birger	573	M	179.0	90.0	'30 • 7 • 21	Athletics Athlétisme
Cederstrom, Eva Gunilla	181	F	177.0	66.0	'43 • 1 • 16	"
Forssander, Bo Erik O.	566	M	186.0	65.0	'42 • 8 • 2	"
Gustafsson, Lars-Erik	568	M	170.0	62.0	'38 • 8 • 17	"
Haglund, Lars Gosta	571	M	198.0	105.0	'40 • 5 • 22	"
Hedmark, Lennart Per-Olov	572	M	193.0	80.0	'44 • 5 • 18	"
Karlsson, Roine Sven T.	574	M	178.0	65.0	'43 • 11 • 12	"
Larsson, Sven-Olov Martin	564	M	175.0	62.0	'38 • 5 • 24	"
Lindback, Stig	562	M	178.0	68.0	'37 • 10 • 2	"
Ljunggren, John Artur	575	M	178.0	59.0	'19 • 9 • 9	"
Najde, Bengt	565	M	170.0	58.0	'42 • 5 • 19	"
Nilsson, Kjell-Ake	569	M	190.0	82.0	'42 • 4 • 5	"
Olofsson, Karl-Uno	563	M	187.0	76.0	'40 • 2 • 16	"
Persson, Bengt Asbjorn	567	M	171.0	58.0	'39 • 10 • 31	"
Pettersson, Ingvar Albin	577	M	174.0	64.0	'26 • 1 • 19	"
Pettersson, Stig	570	M	190.0	74.0	'35 • 3 • 26	"
Soderlund, Ake Wilhelm	576	M	185.0	72.0	'25 • 4 • 11	"
Syversson, Malkolm Roy	578	M	171.0	63.0	'40 • 4 • 9	"
Wieslander, Ulla-Britt	180	F	168.0	54.0	'42 • 6 • 10	"
Emanuelsson, Ove	128	M	183.0	75.0	'41 • 5 • 21	Canoeing Canotage
Ferm, Tyrone	129	M	179.0	75.0	'40 • 11 • 3	"
Ljungdahl, Else-Marie	130	F	160.0	60.0	'42 • 6 • 11	"
Nilsson, Ake	131	M	190.0	78.0	'37 • 12 • 12	"
Peterson, Rolf	132	M	185.0	75.0	'44 • 5 • 11	"
Sahlen, Tord	133	M	179.0	73.0	'37 • 5 • 17	"
Sisth, Eva	134	M	164.0	74.0	'40 • 10 • 16	"
Sjodelius, Sven Olof	135	F	180.0	67.0	'33 • 6 • 13	"
Utterberg, Gunnar	136	M	182.0	68.0	'42 • 11 • 28	"
Von Gerber, Carl	137	M	174.0	72.0	'31 • 8 • 23	"
Hamrin, Sven Helge	135	M	176.0	72.0	'41 • 3 • 30	Cycling Cyclisme
Jansson, Bengt Yngve	139	M	184.0	75.0	'43 • 3 • 21	"
Pettersson, Erik Hakan	136	M	181.0	66.0	'44 • 4 • 4	"
Pettersson, Gosta A. R.	137	M	188.0	75.0	'40 • 11 • 23	"
Pettersson, Sture H. V.	138	M	188.0	75.0	'42 • 9 • 30	"
Soderlund, Curt Joel	140	M	187.0	71.0	'45 • 9 • 2	"
Abrahamson, Goran	220	M	180.0	67.0	'31 • 9 • 19	Fencing Escrime
Engdahl, Carl Wilhelm	221	M	181.0	67.0	'26 • 7 • 16	"
Genesjo, Ivar	222	M	180.0	72.0	'31 • 1 • 24	"
Lagerwall, Hans	223	M	190.0	80.0	'41 • 3 • 1	"

NAME NOM	NO. NO.	SEX SEXE	HEIGHT HAUTEUR	WEIGHT POIDS	DATE OF BIRTH DATE DE NAISSANCE	EVENT EPREUVE	
Lindwall, Orvar	224	M	192.0	71.0	'41 • 8 • 10	Fencing Escrime	Epee Team
Palm, Kerstin	218	F	165.0	63.0	'46 • 2 • 5	"	Foil Ind.
Wahlberg, Christina	219	F	162.0	54.0	'43 • 7 • 24	"	Foil Ind.
Egman, Laila Solveig	81	F	169.0	55.0	'42 • 1 • 6	Gymnastics Gymnastique	
Koorn, Leif	63	M	167.0	58.0	'37 • 7 • 26	"	
Lambert, Anne-Marie	82	F	162.0	55.0	'45 • 6 • 2	"	
Lindahl, Gerola Margareta	83	F	163.0	57.0	'43 • 7 • 20	"	
Lindevall, Stig	64	M	164.0	56.0	'36 • 8 • 15	"	
Lindstrom, Ulla Margareta	84	F	158.0	54.5	'43 • 4 • 17	"	
Lundquist, Anna Marie	85	F	165.0	57.0	'47 • 2 • 21	"	
Rydell, Ewa Margareta	86	F	155.0	50.0	'42 • 2 • 26	"	
Thoresson, William	65	M	171.0	62.0	'32 • 5 • 31	"	
Asp, Per Ingvar	130	M	176.0	88.0	'38 • 10 • 2	Weight-Lifting Haltérophilie	M. Heavy
Edberg, Enar	39	M	162.0	61.0	'36 • 7 • 9	"	Feather
Westlin, Sven Erik	58	M	164.0	69.5	'34 • 1 • 6	"	Light
Eriksson, Knut O.L.		M	189.0	97.0	'39 • 2 • 4	Wrestling Lutte	Free S.-L. Heavy
Jonsson, Bror Rune		M	168.0	70.0	'33 • 5 • 28	"	Greco R.-Light
Nystrom, Bertil Alexis		M	171.0	78.0	'35 • 5 • 22	"	Greco R.-Welter
Olsson, Knut Erik Botvid		M	162.0	63.0	'30 • 1 • 14	"	Greco R.-Feather
Persson, Stig Malte		M	178.0	87.0	'34 • 11 • 28	"	Greco R.-Middle
Poikala, Matti Tapio		M	169.0	70.0	'35 • 7 • 26	"	Free S.-Light
Robertsson, Arne		M	176.0	104.0	'42 • 3 • 23	"	Free S.-Heavy
Svensson, Per Oskar		M	182.0	97.0	'43 • 2 • 6	"	Greco R.-L. Heavy
Svensson, Sten Ragnar		M	190.0	105.0	'34 • 6 • 22	"	Greco R.-Heavy
Andersson, Lotten Katrin		F	165.0	50.5	'50 • 1 • 5	Swimming and Diving Natation et Plongeon	100m Butterfly, 4X100m Free
Bengtsson, W. Lars-Erik		M	187.0	75.0	'42 • 5 • 28	"	1500m Free
Eriksson, Erik Lester		M	185.0	75.0	'42 • 11 • 16	"	100m, 4X100m, 4X200m Free
Eriksson, Karl Ingvar		M	184.0	71.0	'44 • 10 • 1	"	200m Butterfly
Ferm, Sven Olle Erik		M	179.0	65.0	'47 • 3 • 8	"	400m Ind. Medley
Hagberg, Ann-Christine		F	162.0	47.0	'48 • 1 • 20	"	100m, 4X100m Free
Jafvert, Ulla Birgitta E.		F	170.0	60.0	'46 • 4 • 16	"	100m, 4X100m Free
Lilja, Gun Ann-Charlott		F	171.0	54.0	'46 • 6 • 10	"	100m, 400m, 4X100m Free
Lindberg, Per-Ola		M	178.0	69.0	'40 • 3 • 24	"	100m, 4X100m, 4X200m Free
Ljunggren, Elisabeth		F	170.0	55.0	'48 • 2 • 26	"	400m Free, 400m Ind. Medley
Lundin, Jan Ored		M	186.0	70.0	'42 • 9 • 3	"	400m, 4X100m, 4X200m Free
Lundmark, Jan Bertil		M	180.0	70.0	'43 • 12 • 8	"	1500m, 4X100m Free
Lundqvist, Goran C.O.		M	173.0	67.0	'41 • 8 • 4	"	Springboard, High Diving
Nordvall, Bengt-Olof		M	185.0	75.0	'41 • 6 • 1	"	100m, 4X100m Free
Rosendahl, Hans Viktor		M	187.0	85.0	'44 • 12 • 27	"	400m, 4X200m Free
Rybrant, Kerstin Ingegard		F	160.0	53.0	'45 • 2 • 10	"	Springboard Diving
Svensson, Mats Gunnar		M	185.0	75.0	'43 • 4 • 28	"	400m, 4X200m Free
Thunell, Agneta Elisabeth		F	167.0	58.0	'49 • 5 • 24	"	4X100m Free
Welander, Majvor Maria C.		F	169.0	60.0	'50 • 2 • 15	"	400m Free
Edstedt, Lars Henrik	36	M	184.0	73.0	'36 • 6 • 3	Modern Pentathlon Pentathlon Moderne	
Jansson, Bo Herman	37	M	175.0	60.0	'37 • 4 • 20	"	
Junefelt, Rolf Ingmar	38	M	190.0	78.0	'38 • 5 • 15	"	
Liljenwall, Hans-Gunnar	39	M	188.0	74.0	'41 • 7 • 9	"	
Hamilton, William		M	189.0	83.0	'21 • 8 • 15	Equestrian Sports Sport Equestre	Dressage Grand Prix
Ljungquist, Bengt		M	185.0	90.0	'12 • 9 • 20	"	Dressage Grand Prix
Wikne, Hans		M	181.0	75.0	'14 • 9 • 11	"	Dressage Grand Prix
Ahlin, Erik Lennart	50	M	185.0	78.0	'16 • 7 • 26	Shooting Tir	Clay Pigeon
Berntsson, Stig Bertil	275	M	182.0	80.0	'30 • 10 • 19	"	Rapid Fire Pistol
Flodman, Rune Hjalmar	49	M	178.0	89.0	'26 • 4 • 1	"	Clay Pigeon
Larsson, Leif Uno	273	M	174.0	68.0	'28 • 8 • 9	"	Free Pistol
Poignant, Jan Emil	272	M	184.0	85.0	'41 • 11 • 21	"	Free Rifle, Small Bore-3 P., Prone
Sundberg, Nils John	273	M	177.0	79.0	'20 • 12 • 20	"	Free Rifle, Small Bore-3 P., Prone
Andersson, Bernt Erik		M	172.0	72.0	'39 • 9 • 18	Yachting	Reserve
Backer, Ake Erik		M	174.0	68.0	'13 • 6 • 14	"	Reserve
Holm, Styrbjorn John R.		M	190.0	83.0	'28 • 2 • 14	"	Dragon

NAME NOM	NO. NO.	SEX SEXE	HEIGHT HAUTEUR	WEIGHT POIDS	DATE OF BIRTH DATE DE NAISSANCE	EVENT EPREUVE	
Jacobson, Boris Alvar		M	175.0	80.0	'37 • 9 • 13	Yachting	Finn
Kaiser, Bo G. Son		M	173.0	70.0	'30 • 3 • 6	"	Dragon
Kall, Lars Gunnar		M	178.0	72.0	'33 • 11 • 19	"	F. Dutchman
Kall, Stig Lennart		M	180.0	70.0	'38 • 8 • 31	"	F. Dutchman
Karlsson, Arne Ernst		M	174.0	76.0	'36 • 3 • 23	"	5.5m
Pettersson, Pelle Helmer		M	177.0	71.0	'32 • 7 • 31	"	Star
Sarby, Erik Rickard		M	183.0	82.0	'12 • 9 • 19	"	Reserve
Settergren, Arne		M	171.0	63.0	'35 • 3 • 17	"	Dragon
Stork, Sture Henrik		M	178.0	79.0	'30 • 7 • 25	"	5.5m
Sundstrom, Holger Bertil		M	186.0	85.0	'25 • 4 • 17	"	Star
Thorn, Lars Einar V.		M	175.0	70.0	'04 • 9 • 26	"	5.5m
SWITZERLAND SUISSE							
Barandun, Max	579	M	174.0	70.0	'42 • 10 • 25	Athletics Athlétisme	100m
Bosshard, Hansjoerg	585	M	176.0	69.0	'40 • 2 • 1	"	4X400m
Bruder, Hansruedi	586	M	174.0	68.0	'37 • 6 • 2	"	4X400m
Descoux, Jean-Louis	580	M	176.0	70.0	'37 • 11 • 3	"	200m, 4X400m
Duttweiler, Werner	587	M	182.0	77.0	'39 • 11 • 21	"	Pole Vault, Decathlon
Jelinek, Rolf	582	M	183.0	62.0	'36 • 7 • 28	"	800m, 1500m
Knill, Hans-Ruedi	583	M	178.0	70.0	'40 • 5 • 21	"	1500m
Laeng, Peter	581	M	180.0	75.0	'42 • 3 • 29	"	4X400m
Leupi, Oskar	589	M	172.0	64.0	'32 • 11 • 17	"	Marathon
Stutz, Erwin	591	M	182.0	70.0	'36 • 8 • 8	"	50km Road Walk
Theiler, Marius	584	M	180.0	68.0	'38 • 8 • 23	"	4X400m
Voegele, Guido	590	M	171.0	59.0	'37 • 11 • 17	"	Marathon
Von Wartburg, Urs	588	M	187.0	96.0	'37 • 3 • 1	"	Javelin Throw
Bolliger, Peter		M	190.0	88.0	'37 • 5 • 18	Rowing Aviron	Pair, Without Cox
Burgin, Melchior Rudolf		M	180.0	80.0	'43 • 10 • 17	"	Double Sculls
Ehrensperger, Werner		M	155.0	50.0	'40 • 3 • 10	"	Pair, With Cox
Gobet, Nicolas		M	192.0	90.0	'38 • 12 • 28	"	Pair, Without Cox
Kottmann, Gottfried		M	184.0	85.0	'32 • 10 • 15	"	Single Sculls
Studach, Martin Andreas		M	176.0	80.0	'44 • 5 • 17	"	Double Sculls
Waser, Adolf		M	187.0	82.0	'38 • 2 • 5	"	Pair, With Cox
Waser, Hugo		M	190.0	89.0	'36 • 8 • 9	"	Pair, With Cox
Horvath, Bela-Istvan	238	M	182.0	80.0	'37 • 1 • 31	Boxing Boxe	L. Heavy
Meier, Rudolf	239	M	180.0	84.0	'39 • 6 • 23	"	Heavy
Heinemann, Heinz	141	M	180.0	75.0	'40 • 8 • 14	Cycling Cyclisme	Road Ind., Team T. T.
Jausli, Erwin	142	M	169.0	63.0	'37 • 1 • 28	"	Ind. Road
Luthi, Hans	143	M	173.0	72.0	'39 • 3 • 15	"	Road Ind., Team T. T.
Pfenninger, Louis	133	M	183.0	70.0	'44 • 11 • 1	"	Road Team T. T.
Rutschmann, Rene	144	M	185.0	78.0	'41 • 1 • 7	"	Road Ind., Team T. T.
Bar, Walter	228	M	182.0	68.0	'38 • 7 • 5	Fencing Escrime	Epee Ind., Team
Gontier, Jean	227	M	185.0	86.0	'42 • 1 • 26	"	Epee Ind., Team
Meister, Paul	226	M	186.0	74.0	'26 • 1 • 20	"	Epee Ind., Team
Polledri, Claudio	229	M	178.0	80.0	'36 • 1 • 7	"	Epee Ind., Team
Steininger, Michel	225	M	185.0	75.0	'35 • 2 • 5	"	Epee Ind., Team
Berchtold, Meinrad	185	M	163.0	56.0	'43 • 12 • 3	Gymnastics Gymnastique	
Egger, Fredy	182	M	173.0	66.0	'41 • 3 • 2	"	
Fah, Franz	187	M	170.0	62.0	'37 • 11 • 22	"	
Fassler, Gottlieb	184	M	164.0	59.0	'34 • 4 • 13	"	
Feuz, Fritz	181	M	170.0	64.0	'31 • 4 • 28	"	
Michel, Werner	186	M	172.0	66.0	'33 • 5 • 21	"	
Muller, Walter	183	M	174.0	67.0	'40 • 3 • 5	"	
Lab, Philippe	59	M	161.0	67.5	'41 • 7 • 13	Weight-Lifting Haltérophilie	Light
Haenni, Eric		M	172.0	.	'38 • 12 • 19	Judo	Light Weight
Jutzeler, Peter		M	182.0	97.0	'40 • 5 • 9	Wrestling Lutte	Free S., Greco R.-L. Heavy
Kobelt, Max		M	178.0	87.0	'41 • 1 • 5	"	Greco R.-Middle
Kobelt, Rudolf		M	179.0	87.0	'43 • 4 • 20	"	Free S.-Middle
Brack, Ruedi		M	192.0	90.0	'41 • 5 • 15	Swimming and Diving Natation et Plongeon	200m Breast
Caperonis, Pano		M	177.0	70.0	'47 • 8 • 16	"	100m, 400m, 1500m Free

NAME NOM	NO. NO.	SEX SEXE	HEIGHT HAUTEUR	WEIGHT POIDS	DATE OF BIRTH DATE DE NAISSANCE	EVENT EPREUVE	
Chammartin, Henri		M	175.0	68.0	'18 • 7 • 30	Equestrian Sports Sport Equestre	Dressage Grand Prix
Fischer, Gustav		M	175.0	72.0	'15 • 11 • 8	"	Dressage Grand Prix
Gossweiler, Marianne		F	172.0	64.0	'43 • 5 • 15	"	Dressage Grand Prix
Hauri, Max		M	170.0	73.0	'41 • 12 • 30	"	Jumping Grand Prix
Lombard, Frank		M	175.0	66.0	'19 • 5 • 3	"	Jumping Grand Prix
Moehr, Hans		M	170.0	80.0	'16 • 6 • 23	"	Jumping Grand Prix
Weier, Paul		M	172.0	66.0	'34 • 12 • 3	"	Jumping Grand Prix
Albrecht, Hans		M	172.0	74.0	'24 • 9 • 7	Shooting Tir	Rapid Fire Pistol
Hemauer, Ludwig		M	172.0	71.0	'17 • 8 • 3	"	Free Pistol
Hollenstein, August		M	178.0	82.0	'20 • 3 • 28	"	Free Rifle
Muller, Kurt		M	186.0	97.0	'34 • 4 • 4	"	Free Rifle, Small Bore-3 P.
Schneider, Hansruedi		M	175.0	80.0	'26 • 12 • 22	"	Rapid Fire Pistol
Simonet, Hans		M	171.0	72.0	'35 • 6 • 24	"	Small Bore-Prone
Stoll, Ernst		M	165.0	79.0	'27 • 6 • 4	"	Free Pistol
Vogt, Erwin		M	176.0	90.0	'31 • 9 • 17	"	Small Bore-3 P., Prone
Bryner, Hans Robert		M	165.0	70.0	'11 • 3 • 19	Yachting	Star
Bucher, Urs		M	188.0	98.0	'26 • 9 • 6	"	Star
Buzzi, Michel S. R.		M	173.0	66.0	'39 • 6 • 25	"	F. Dutchman
Dunand, Bernard Guy		M	175.0	83.0	'36 • 9 • 2	"	Reserve
Graul, Jean E. M.		M	189.0	100.0	'24 • 7 • 19	"	5.5m
Ott, Jean Garl		M	187.0	78.0	'17 • 8 • 27	"	Reserve
Ramelet, Paul		M	172.0	98.0	'09 • 11 • 27	"	5.5m
Renavier, Jean-Pierre		M	175.0	75.0	'28 • 11 • 29	"	F. Dutchman
Rouge, Roger M. E.		M	167.0	70.0	'14 • 6 • 1	"	5.5m
TAIWAN TIWAN							
Chi, Cheng	190	F	172.0	62.0	'44 • 3 • 15	Athletics Athlétisme	80m Hurdles, Long Jump, Pentathlon
Lee, Ar Tu	626	M	170.0	66.0	'37 • 11 • 21	"	100m, 200m
Lin, Kuei Chang	627	M	176.0	73.0	'39 • 11 • 1	"	110m Hurdles
Wu, Ar Min	629	M	180.0	75.0	'38 • 7 • 19	"	Pole Vault, Decathlon
Yang, Chuan Kwang	628	M	185.0	81.0	'33 • 7 • 11	"	Pole Vault, Javelin Throw, Decathlon
Yeh, Chu Mei	189	F	159.0	52.0	'44 • 6 • 12	"	200m, 80m Hurdles
Chang, Pin Cheng	244	M	185.0	63.5	'37 • 3 • 3	Boxing Boxe	L. Welter
Chen, Bai Sun	246	M	178.0	71.0	'32 • 5 • 2	"	L. Middle
Hong, Tshun Fu	245	M	176.0	67.0	'40 • 1 • 24	"	Welter
Hsu, Hung Cheng	242	M	170.0	57.0	'41 • 8 • 1	"	Feather
Lee, Chen Chu	241	M	165.0	54.0	'40 • 5 • 7	"	Bantam
Wang, Chi Chu	243	M	168.0	60.0	'41 • 5 • 30	"	Light
Wang, Chi Ying	240	M	164.0	51.0	'46 • 12 • 20	"	Fly
Deng, Chuen Hwai	136	M	170.0	69.0	'40 • 11 • 18	Cycling Cyclisme	Ind., Team Pursuit, Road Ind., Team T. T.
Her, Jong Chau	137	M	169.0	57.0	'46 • 1 • 5	"	Team Pursuit, Road Ind., Team T. T.
Lin, Yuh Sheng	140	M	168.0	62.0	'43 • 11 • 29	"	Scratch Sprint
Shue, Ming Shyh	138	M	171.0	69.0	'40 • 6 • 15	"	1000m T. T., Team Pursuit, Road Ind., Team T. T.
Yang, Rong Hwa	139	M	170.0	63.0	'42 • 9 • 19	"	Team Pursuit, Road Team T. T.
Chai, Kuang Tai	186	F	152.0	44.0	'45 • 7 • 1	Gymnastics Gymnastique	
Hong, Than Kwai	185	F	152.0	47.5	'46 • 12 • 8	"	
Jan, Thai San	71	M	157.0	54.0	'38 • 1 • 3	"	
Lai, Chu Long	75	M	168.0	55.0	'42 • 3 • 10	"	
Lee, Bu Ti	72	M	163.5	54.0	'41 • 4 • 11	"	
Liuh, Reng Suhn	76	M	156.0	54.0	'41 • 10 • 28	"	
Uih, Yah Torh	74	M	160.0	57.0	'38 • 8 • 10	"	
Wang, Shian Ming	73	M	160.0	52.0	'40 • 9 • 8	"	
Chang, Ming Chung	40	M	164.0	60.0	'42 • 1 • 3	Weight-Lifting Haltérophilie	Feather
Chao, Cheng Hsueg	88	M	170.0	74.0	'40 • 1 • 31	"	Middle
Cheng, Cheng Chung	110	M	170.0	81.0	'36 • 7 • 9	"	L. Heavy
Cheng, Sheng Teh	131	M	176.0	85.0	'41 • 8 • 24	Weight-Lifting Haltérophilie	M. Heavy
Chung, Nan Fei	27	M	156.0	56.0	'28 • 1 • 12	"	Bantam
Oun, Yao Ling	153	M	180.0	95.0		"	Heavy
Yeh, Juei Feng	60	M	167.0	65.0	'38 • 3 • 18	"	Light
Chang, Chung Hwei		M	175.0	90.0	'36 • 7 • 15	Judo	Heavy Weight

NAME NOM	NO. NO.	SEX SEXE	HEIGHT HAUTEUR	WEIGHT POIDS	DATE OF BIRTH DATE DE NAISSANCE	EVENT EPREUVE
Chang, Won Ku		M	177.0	68.0	'35 • 11 • 27	Judo Light Weight
Huang, Chin Chun		M	172.0	73.0	'40 • 2 • 5	" Middle Weight
Huang, Yong Chun		M	173.0	88.0	'35 • 10 • 1	" Heavy Weight
Lin, Homing	42	M	173.0	59.0	'28 • 6 • 27	Shooting Tir Clay Pigeon
Lin, Wen Chu	41	M	164.0	62.0	'29 • 5 • 22	" Clay Pigeon
Ma, Chen Shan	287	M	170.0	73.0	'26 • 5 • 21	" Rapid Fire Pistol
Pan, Kouang	285	M	165.0	48.0	'39 • 12 • 8	" Small Bore-Prone
Tai, Chao Chih	286	M	177.0	78.0	'30 • 3 • 13	" Small Bore-Prone
Wu, Tao Yuan	284	M	167.6	41.0	'24 • 9 • 4	" Free Rifle, Small Bore-3 P.
TANGANYIKA TANGANYIKA						
Abdallah, Omari	595	M	168.0	56.7	'43 • 5 • 5	Athletics Athlétisme Marathon
Chabbanga, Mohamed Hassan	593	M	177.0	61.5	'41 • 6 •	" 800 m
Mfyomi, Paschal	594	M	162.0	52.6	'42 • 7 •	" 5000m, 10000m
Thomas, Daniel	592	M	178.0	63.5	'37 • 1 •	" 400 m
THAILAND THAILANDE						
Arjtaweekul, Taweesit	601	M	173.0	59.0	'41 • 1 • 9	Athletics Athlétisme 4X100m
Bhakdikul, Katesepwasdi	607	M	180.0	67.0	'41 • 10 • 17	" High Jump
Bumroonspruek, Manun	605	M	164.0	54.0	'36 • 4 • 5	" 4X400m
Charanggool, Samroey	183	F	160.0	50.0	'44 • 7 • 3	" 400m, 800m, 4X100m
Dechdumrong, Preya	185	F	152.0	44.0	'45 • 1 • 24	" 4X100m
Kanitasut, Chalit	603	M	160.0	59.0	'40 • 12 • 5	" 4X100m
Keocanta, Sermsak	600	M	165.0	70.0	'39 • 7 • 23	" 5000 m
Kitipongpitaya Pranee	188	F	166.0	65.0	'42 • 8 • 9	" Discus Throw
Klai Arngtong, Tira	599	M	165.0	56.0	'43 • 6 • 27	" 1500m
Klaichai, Chinda	184	F	152.0	45.0	'41 • 4 • 1	" 4X100m
Leenasen, Tipapan	187	F	162.0	50.0	'43 • 9 • 9	" High Jump
Manyakass, Suthi	596	M	160.0	60.0	'38 • 8 • 10	" 100m, 4X100m
Pensuvabharp, Nipon	598	M	175.0	64.0	'41 • 3 • 7	" 800m, 4X400m
Sirirangsri, Chanom	608	M	171.0	53.0	'35 • 3 • 12	" Marathon
Soraja, Kusolwan	182	F	162.0	53.0	'41 • 1 • 1	" 100m, 200m, 4X100m
Tongsuke, Somsakdi	597	M	168.0	64.0	'39 • 1 • 9	" 200m, 400m, 4X100m, 4X400m
Vajchareevongse, Intachot	604	M	174.0	60.0	'36 • 7 • 29	" 4X100m, 4X400m
Vilaiakit, Maitri	602	M	164.0	52.0	'44 • 1 • 18	" 4X100m
Vitsudhamakul, Adisorn	606	M	179.0	60.0	'39 • 4 • 1	" 4X400m
Yimploy, Busbong	186	F	159.0	50.0	'47 • 1 • 17	" 4X100m
Komolsen, Veerapan	247	M	164.0	51.0	'46 • 3 • 16	Boxing Boxe Fly
Prasertsom, Niyom	249	M	175.0	63.5	'43 • 7 • 3	" L. Welter
Songsang, Sukda	250	M	174.0	67.0	'41 • 10 • 24	" Welter
Thiancharoen, Yot	251	M	175.0	71.0	'38 • 1 • 19	" L. Middle
Udompichitkul, Cherdchai	248	M	164.0	54.0	'41 • 12 • 16	" Bantam
Chantarasamriti, Somchai	142	M	168.0	61.0	'44 • 11 • 5	Cycling Cyclisme Team Pursuit
Charemratanana, Vitool	149	M	168.0	65.0	'42 • 9 • 11	" Road Ind., Team T. T.
Chillananda, Pakdi	148	M	185.0	72.0	'46 • 8 • 14	" Road Ind., Team T. T.
Chullamondhol, Preeda	141	M	180.0	72.0	'45 • 8 • 21	" 1000m T. T., Team Pursuit
Jirapan, Tarwon	150	M	157.0	56.0	'39 • 4 • 1	" Road Ind., Team T. T.
Kerdutubtim, Pitaya	145	M	163.0	58.0	'42 • 10 • 30	" Reserve
Krisansuwan, Smaisuk	143	M	175.0	67.0	'43 • 7 • 8	" Ind., Team Pursuit
Ornkerd, Suwan	146	M	167.0	73.0	'41 • 5 • 12	" Reserve
Sophonpong, Chainarong	151	M	160.0	65.0	'44 • 2 • 1	" Road Ind., Team T. T.
Warayut, Chuchat	144	M	165.0	59.0	'40 • 6 • 29	" Team Pursuit
Chongrak, Sermbhan	28	M	152.0	56.0	'38 • 8 • 31	Weight-Lifting Halterophilie Bantam
Haroon, Niras	61	M	168.0	67.0	'42 • 1 • 27	" Light
Ratanasuksofphona, Visist	89	M	168.0	75.0	'40 • 8 • 18	" Middle
Sukchinda, Chaia	14	M	160.0	54.0	'35 • 4 • 15	" Bantam
Tiamsert, Snan	41	M	165.0	60.0	'39 • 1 • 31	" Feather
Harssarungsri, Eiam		M	166.0	66.0	'39 • 7 • 15	Judo Light Weight
Rasmelungon, Udom		M	175.0	64.0	'44 • 11 • 3	" Light Weight
Sinhasema, Pipat		M	179.0	78.0	'39 • 12 • 13	" Middle Weight
Chodtipanang, Somchai		M	165.0	52.0	'15 • 10 • 12	Swimming and Diving Natation et Plongeon 200m Back, 4X100m Medley

NAME NOM	NO. NO.	SEX SEXE	HEIGHT HAUTEUR	WEIGHT POIDS	DATE OF BIRTH DATE DE NAISSANCE	EVENT EPREUVE	
Chok Umnuay, Narong		M	169.0	58.0	'44 • 9 • 21	Swimming and Diving Natation et Plongeon	200m Butterfly, 400m Ind. Medley, 4X100m Medley
Klumbanjong, Virayuth		M	179.0	64.0	'39 • 10 • 7	"	200m Breast, 4X100m Medley
Limpichati, Somchai		M	174.0	71.0	'40 • 12 • 10	"	100m Free, 400m Ind. Medley, 4X100m Medley
Arunvongse, Krisda	291	M	165.0	65.0	'32 • 1 • 9	Shooting Tir	Small Bore-3 P.
Chaiyanitr, Choomphol	292	M	172.0	53.0	'21 • 3 • 23	"	Small Bore-Prone
Darbavasu, Turong	289	M	172.0	93.0	'30 • 9 • 4	"	Free Rifle
Kasiwat, Tawesak	296	M	175.0	80.0	'32 • 8 • 10	"	Rapid Fire Pistol
Pancharatana, Xan	288	M	167.0	67.0	'41 • 5 • 26	"	Free Rifle
Purnaveja, Hongsa	293	M	171.0	57.0	'28 • 3 • 28	"	Small Bore-Prone
Smuthranond, Paitool	294	M	164.0	65.0	'31 • 7 • 1	"	Free Pistol
Srisathorn, Salai	290	M	150.0	50.0	'33 • 11 • 17	"	Small Bore-3 P.
Sumanatemega, Sumon	297	M	164.0	78.0	'32 • 8 • 17	"	Rapid Fire Pistol
Yuktanan, Amorn	295	M	171.0	64.0	'28 • 6 • 16	"	Free Pistol
Areerob, P.		M	.	.	'24 • 3 • 16	Yachting	Dragon
Bira, Prince		M	.	.	'14 • 7 • 15	"	Dragon
Bira, Princess		F	.	.	'30 • 9 • 15	"	Dragon
Bunnag, Prason		F	152.0	50.0	'27 • 10 • 26	"	Reserve
Kanjanavanit, Rachot		M	.	.	'24 • 8 • 5	"	Finn
TRINIDAD AND TOBAGO TRINIDAD ET TOBAGO							
Bernard, Kent	612	M	185.0	77.5	'42 • 9 • 27	Athletics Athlétisme	400m, 4X400m
Bertrand, Clifton	611	M	180.0	72.5	'36 • 3 • 2	"	200m, 4X400m
Jackson, Wilton	610	M	170.0	70.0	'37 • 11 • 15	"	100m, 200m, 4X400m
Mottley, Wendell	613	M	172.5	73.0	'41 • 7 • 2	"	400m, 4X400m
Roberts, Edwin	609	M	172.5	72.0	'41 • 8 • 12	"	100m, 200m, 4X400m
Skinner, Edwin	614	M	.	.	'40 • 10 • 15	"	400m, 4X400m
Cassidy, Ronald	149	M	182.5	75.0	'39 • 2 • 4	Cycling Cyclisme	Ind. Pursuit, Ind. Road
Gibbon, Roger	147	M	175.0	76.0	'44 • 3 • 9	"	1000m T. T., Scratch Sprint
Hoyte, Fitzroy	148	M	175.0	77.0	'40 • 7 • 6	"	Scratch Sprint
Bailey, Brandon	154	M	182.5	115.0	'32 • 11 • 5	Weight-Lifting Haltérophilie	Heavy
Gittens, Hugo	62	M	167.5	68.0	'36 • 9 • 24	"	Light
Barrow, Cordel Hull		M	182.0	73.0	'40 • 4 • 15	Yachting	F. Dutchman
Barrow, Rawle H. D.		M	178.0	82.0	'34 • 9 • 21	"	F. Dutchman
TUNISIA TUNISIE							
Belkhodja, Hassine	621	M	175.0	70.0	'39 • 1 • 26	Athletics Athlétisme	20km Road Walk
Ben Boubaker, Hedhili	618	M	174.0	58.7	'38 •	"	Marathon
Ben Messaoud, Naceur	619	M	190.0	75.0	'39 •	"	20km, 50km Road Walk
El Marghni, Chedli	620	M	172.0	65.0	'38 •	"	20km, 50km Road Walk
Gammoudi, Mohamed	615	M	171.0	61.7	'38 •	"	5000m, 10000m, Marathon
Hannachi, M. Haddeb	616	M	175.0	63.5	'38 •	"	10000m, Marathon
Labidi Taouadi, Ayachi	617	M	168.0	68.0	'38 • 3 • 15	"	3000m S. C.
Ben Hassen, Tahar	252	M	171.0	57.0	'41 • 7 • 24	Boxing Boxe	Feather
Galhia, Habib	253	M	165.0	63.0	'41 • 5 • 14	"	L. Welter
Hachicha, Ali		M	175.0	.	'39 • 4 •	Judo	All Weights
TURKEY TURQUIE							
Dalkilic, Muharrem	622	M	176.0	65.0	'38 • 2 • 10	Athletics Athlétisme	1500m, 5000m, 10000m
Onel, Cahit	624	M	170.0	60.0	'27 • 11 • 23	"	3000m S. C.
Sahiner, Cetin	623	M	186.0	78.0	'34 •	"	110m Hurdles
Tuna, Askin	625	M	180.0	76.0	'40 • 7 • 21	"	Triple Jump
Pekunlu, Sadik	132	M	176.0	86.0	'38 •	Weight-Lifting Haltérophilie	M. Heavy
Akbas, Huseyin		M	.	.	'33 •	Wrestling Lutte	Free S.-Bantam
Atalay, Mahmut		M	170.0	70.0	'34 • 3 • 30	"	Free S.-Light
Ayik, Ahmet		M	178.0	97.0	'38 • 3 • 31	"	Free S.-L. Heavy
Ayvaz, Kazim		M	170.0	70.0	'38 • 3 • 10	"	Greco R.-Light
Basergil, Unver		M	166.0	57.0	'38 • 3 • 25	"	Greco R.-Bantam
Bayrak, Mithat		M	173.0	78.0	'29 • 3 • 3	"	Greco R.-Welter
Bozkurt, Burhan		M	164.0	52.0	'34 •	"	Greco R.-Fly
Gungor, Hasan		M	178.0	87.0	'34 • 7 • 5	"	Free S.-Middle
Kaplan, Hamit		M	190.0	97.0	'34 • 9 • 20	"	Free S.-Heavy, Greco R.-L. Heavy
Ogan, Ismail		M	170.0	73.0	'33 • 3 • 5	"	Free S.-Welter

NAME NOM	NO. NO.	SEX SEXE	HEIGHT HAUTEUR	WEIGHT POIDS	DATE OF BIRTH DATE DE NAISSANCE	EVENT EPREUVE
Sahinkaya, Hayrullah		M	169.0	63.0	'34 • 2 • 1	Wrestling Lutte
Selekman, Ismail Yavuz		M	178.0	87.0	'37 • 2 • 15	"
Sille, Muzahir		M	169.0	63.0	'31 • 9 • 21	"
Yanilmaz, Cemal		M	160.0	52.0	'34 • 1 • 2	"
Yilmaz, Kiyasettin		M	180.0	97.0	'38 • 5 • 6	"
Akdurak, Metin		M	187.0	85.0	'36 • 2 • 21	Yachting
Arsal, Erdogan		M	171.0	75.0	'33 • 12 • 20	"
Kakis, Hayrullah		M	172.0	78.0	'32 • 1 • 25	"
U.A.R. R.A.U.						
Aboushanab, Abdelfatah		M	.	.	'35 • 10 • 15	Rowing Aviron
Ali, Abdallah		M	.	.	'36 • 5 • 3	"
Ali, Abdelradi		M	.	.	'39 • 11 • 1	"
Ali, Abdelsami		M	.	.	'36 • 1 • 6	"
Eissa, Mohamed		M	.	.	'36 • 5 • 15	"
Elhalawani, Mohamed		M	.	.	'36 • 8 • 15	"
Ibrahim, Ahmed		M	.	.	'38 • 12 • 8	"
Ibrahim, Metwalli		M	.	.	'36 • 10 • 20	"
Ibrahim, Sabry Sayed		M	.	.	'36 • 8 • 31	"
Ibrahim, Saleh		M	.	.	'36 • 3 • 2	"
Khamis, Abbas		M	.	.	'33 • 3 • 20	"
Mashhour, Salem		M	.	.	'40 • 11 • 20	"
Metwalli, Abdellatif		M	.	.	'36 • 3 • 17	"
Nasr, Mahmoud		M	.	.	'36 • 8 • 21	"
Saad, Abdelmohsen		M	.	.	'36 • 12 • 31	"
Shehata, Mahmoud		M	.	.	'38 • 12 • 31	"
Elbedewi, Badawi	256	M	.	.	'42 • 5 • 14	Boxing Boxe
Elnahas, Sayed	259	M	.	.	'39 • 11 • 29	"
Farag, Hosni	255	M	.	.	'44 • 5 • 14	"
Hassan, Ahmed	260	M	.	.	'41 • 9 • 12	"
Hassan, Fawzi	257	M	.	.	'39 • 1 • 23	"
Mersal, Mahmoud	254	M	.	.	'40 • 12 • 16	"
Mersal, Sayed	261	M	.	.	'37 • 1 • 22	"
Saddik, Hussein	258	M	.	.	'39 • 4 • 5	"
Abdelrahman, Sameh	235	M	.	.	'43 • 10 • 5	Fencing Escrime
Elashmawi, Farid	234	M	.	.	'41 • 6 • 29	"
Elhossen, Ahmed	233	M	.	.	'39 • 3 • 9	"
Elkalyoubi, M.	231	M	.	.	"	"
Mohamed, Gamil	232	M	.	.	'37 • 4 • 7	"
Sehem, Mostafa	230	M	.	.	'37 • 3 • 20	"
Ahmed, Reda M.	2	M	.	.	'39 • 11 • 9	Football
Amin, Darwish	9	M	.	.	'42 • 3 • 20	"
Attia, Raafat	11	M	.	.	'34 • 2 • 6	"
Badawi, Mohamed A.	19	M	.	.	'35 • 5 • 24	"
Elfanagili, Rifaat	12	M	.	.	'36 • 5 • 1	"
Elisnawi, Amin	7	M	.	.	'36 • 6 • 23	"
Elsherbini, M. Abdelat	15	M	.	.	'37 • 7 • 26	"
Eltabbakh, Elsayed	20	M	.	.	'40 • 11 • 3	"
Etman, K. Aly	18	M	.	.	'41 • 6 • 6	"
Gad, Ahmed Moust	8	M	.	.	'40 • 3 • 8	"
Hassan, Mahmoud	13	M	.	.	'43 • 11 • 19	"
Ismail, Taha	16	M	.	.	'39 • 2 • 8	"
Korshed, F. Aly	1	M	.	.	'37 • 12 • 11	"
Kotb, Mohamed M.	17	M	.	.	'38 • 3 • 16	"
Mahmoud, Farouk	14	M	.	.	'44 • 10 • 18	"
Mohamed, Seddik	5	M	.	.	'40 • 4 • 14	"
Nosseir, Nabil	4	M	.	.	'38 • 10 • 11	"
Riad, Ibrahim	3	M	.	.	'41 • 4 • 5	"
Shahin, Kalil M	6	M	.	.	'42 • 3 • 2	"
Zaki, Yaken	10	M	.	.	'34 • 9 • 12	"

NAME NOM	NO. NO.	SEX SEXE	HEIGHT HAUTEUR	WEIGHT POIDS	DATE OF BIRTH DATE DE NAISSANCE	EVENT EPREUVE
Ibrahim, Mohamed	192	M	.	.	'42 • 8 • 4	Gymnastics Gymnastique
Abbas, Hosni	53	M	.	.	'32 • 7 • 15	Weight-Lifting Halterophilie
El Hanafi, M. A.	111	M	.	.	'34 • 12 • 16	"
Hereit, Mohamed	29	M	.	.	'37 • 4 • 16	"
Ibrahim, Mohamed	160	M	.	.	'37 • 8 • 5	"
Saleh, Hessein	75	M	.	.	'36 • 10 • 12	"
Ali, Foad		M	.	.	'36 • 3 • 6	Wrestling Lutte
Ali, Kamal		M	.	.	'35 • 5 • 13	"
Ibrahim, Mahmoud		M	.	.	'37 • 11 • 24	"
Mansour, Mostafa		M	.	.	'30 • 7 • 8	"
Atia, Elsayed Hassan	300	M	.	.	'31 • 11 • 10	Shooting Tir
Elkateb, Mohamed Sami	298	M	.	.	'36 • 2 • 1	"
Fikry, Mohamed Amin	299	M	.	.	'41 • 3 • 7	"
Guenena, Ahmed Kadry	26	M	.	.	'35 • 7 • 17	"
Mehrez, Mohamed Chahin	25	M	.	.	'35 • 7 • 17	"
Zohdy Abdallah, Abdallah	301	M	.	.	'28 • 12 • 3	"
Amin, Abdelrahman		M	.	.	'41 • 12 • 31	Water Polo
Amr, Mamdouh		M	.	.	'46 • 5 • 26	"
Elgamal, Hussein		M	.	.	'35 • 8 • 5	"
Elkachef, Kaled		M	.	.	'46 • 10 • 1	"
Elmealem, Adel		M	.	.	'46 • 11 • 26	"
Elsayed, Sami		M	.	.	'40 • 10 • 21	"
Farag, Goubran		M	.	.	'40 • 8 • 12	"
Gamil, Ashraf		M	.	.	'46 • 4 • 1	"
Kalil, Mohamed		M	.	.	'39 • 3 • 5	"
Kourched, Hazem		M	.	.	'43 • 7 • 5	"
Soliman, Mohamed		M	.	.	'45 • 8 • 20	"
UGANDA OUGANDA						
Amukun, Erasmus	631	M	167.8	62.5	'41 • 11 • 28	Athletics Athlétisme
Awori, Aggrey	632	M	185.4	74.8	'39 • 3 • 23	"
Kamanyi, William	636	M	171.1	62.0	'42 • 7 • 3	"
Musani, Mary	192	F	158.7	60.0	'44 • 9 • 4	"
Muyanca, Irene P. M.	191	F	162.5	55.0	'43 • 11 • 12	"
Ochana, Jerom	635	M	176.5	71.0	'35 • 6 • 21	"
Odeke, George	637	M	.	78.0	'40 • 3 • 5	"
Oduka, James Odongo	630	M	170.2	73.0	'44 • 12 • 4	"
Okiring, Vircil	634	M	175.2	67.0	'42 • 9 • 25	"
Omolo, Amos	633	M	177.8	71.0	'37 • 3 • 9	"
Mabwa, Ernest Powell	283	M	172.7	67.0	'41 • 1 • 26	Boxing Boxe
Mugwanya, Henry	285	M	177.8	80.0	'43 • 8 • 10	"
Odhiambo, Alex	282	M	180.3	60.0	'43 • 10 • 10	"
Odhiambo, Peter Paul	284	M	180.3	75.0	'37 • 9 • 9	"
Oywello, George	286	M	182.8	82.0	'40 • 1 • 17	"
URUGUAY URUGUAY						
Caulin, Mariano		M	182.0	82.0	'38 • 5 • 22	Rowing Aviron
Perez, Gustavo		M	179.0	82.0	'35 • 8 • 5	"
Ciavattone, Edison A.	8	M	180.0	81.0	'38 • 9 • 20	Basket-Ball
De Leon, Ramiro Eduardo	13	M	179.0	82.0	'38 • 3 • 18	"
Gadea, Manuel Roberto	12	M	186.0	77.0	'42 • 1 • 2	"
Garcia, Luis Agustin	11	M	187.0	85.0	'41 • 6 • 21	"
Gomez, Julio Cesar	6	M	178.0	89.0	'40 • 11 • 8	"
Koster, Luis Eduardo	7	M	182.0	84.0	'42 • 3 • 24	"
Marquez, Walter	5	M	181.0	85.0	'36 • 10 • 28	"
Maya, Jorge	15	M	177.0	79.0	'44 • 5 • 5	"
Pisano, Sergio	10	M	191.0	92.0	'41 • 6 • 13	"
Poyet, Washington A.	4	M	189.0	91.0	'39 • 1 • 12	"
Rial, Waldemar Jose	14	M	191.0	100.0	'40 • 2 • 3	"
Roca, Alvaro Eduardo	9	M	190.0	88.0	'39 • 10 • 16	"
Rodriguez, Washington	287	M	159.0	54.0	'44 • 4 • 6	Boxing Boxe

NAME NOM	NO. NO.	SEX SEXE	HEIGHT HAUTEUR	WEIGHT POIDS	DATE OF BIRTH DATE DE NAISSANCE	EVENT EPREUVE
Almada, Oscar	150	M	174.0	68.0	'43 • 10 • 18	Cycling Cyclisme 1000m T. T., Team Pursuit
Baridon, Wilde H.	155	M	.	71.0	'41 • 4 • 26	" Road Ind., Team T. T.
Cencic, Vid	156	M	179.0	89.0	'33 • 5 • 9	" Road Ind., Team T. T.
Etchebarne, Ruben	151	M	177.0	76.0	'36 • 9 • 8	" Ind., Team Pursuit
Juarez, Elio	152	M	.	72.0	'42 • 4 • 18	" Team Pursuit
Perez, Francisco	157	M	.	71.0	'34 • 2 • 4	" Road Ind., Team T. T.
Timon, Juan Jose	153	M	174.0	66.0	'37 • 11 • 18	" Team Pursuit, Road Ind., Team T. T.
Vazquez, Ricardo	154	M	174.0	75.0	'32 • 9 • 25	" Reserve
U.S.A ETATS-UNIS						
Ashworth, Gerald Howar d	732	M	180.0	75.0	'42 • 5 • 1	Athletics Athlétisme 4X100m
Bair, Ranae Jean	234	F	180.0	61.0	'43 • 3 • 9	" Javelin Throw
Baskerville, Estelle	229	F	165.0	57.0	'46 • 11 • 15	" High Jump
Bonds, Rosie	223	F	173.0	61.0	'44 • 7 • 7	" 80m Hurdles, 4X100m
Boston, Ralph Harold	740	M	178.0	73.0	'39 • 5 • 9	" Long Jump
Brodie, Michael Warren	763	M	178.0	62.0	'41 • 6 • 17	" 50km Road Walk
Brown, Earlene Dennis	232	F	175.0	114.0	'35 • 7 • 11	" Shot Put
Brown, Terrezene	227	F	174.0	61.0	'47 • 9 • 27	" High Jump
Brown, Vivian Delores	219	F	173.0	63.0	'41 • 11 • 17	" 200m
Burke, Edward A.	755	M	186.0	100.0	'40 • 3 • 4	" Hammer Throw
Burleson, Dyrrol	714	M	188.0	73.0	'40 • 5 • 27	" 1500m
Carr, Henry	705	M	191.0	84.0	'42 • 11 • 27	" 200m, 4X400m
Caruthers, Edward J.	734	M	198.0	86.0	'43 • 4 • 13	" High Jump
Cassell, Ollan C.	708	M	187.0	73.0	'37 • 10 • 5	" 400m, 4X400m
Cawley, Warren Jay	726	M	183.0	75.0	'40 • 7 • 6	" 400m Hurdles, 4X400m
Connolly, Harold Vincent	756	M	183.0	109.0	'31 • 8 • 1	" Hammer Throw
Connolly, Olga Fikotova	233	F	178.0	77.0	'32 • 11 • 13	" Discus Throw
Covelli, Frank George	752	M	188.0	89.0	'37 • 4 • 2	" Javelin Throw
Davenport, Willie D.	723	M	186.0	80.0	'43 • 6 • 8	" 110m Hurdles
Davis, Ira Sylvester	743	M	183.0	70.0	'36 • 9 • 25	" Triple Jump
Dellinger, William S.	717	M	175.0	64.0	'34 • 3 • 23	" 5000m
Drayton, Otis Paul	706	M	183.0	73.0	'39 • 5 • 8	" 200m, 4X100m
Edelen, Leonard G.	758	M	178.0	64.0	'37 • 9 • 22	" Marathon
Emberger, Richard John	766	M	183.0	77.0	'38 • 7 • 3	" Decathlon
Farrell Thomas Francis	711	M	170.0	64.0	'44 • 1 • 18	" 800m
Fishback, Jeffrey M.	729	M	189.0	75.0	'41 • 11 • 20	" 3000m S. C.
Floerke, Kent Lee	744	M	193.0	91.0	'36 • 1 • 16	" Triple Jump
Grissom, Joann Terry	230	F	170.0	64.0	'38 • 8 • 4	" Long Jump
Groth, Morgan Austin	712	M	186.0	68.0	'43 • 8 • 31	" 800m
Hall, Albert William	757	M	185.0	105.0	'34 • 8 • 2	" Hammer Throw
Hansen, Fred Morgan	737	M	183.0	75.0	'40 • 1 • 29	" Pole Vault
Hardin, William Foster	727	M	186.0	77.0	'42 • 1 • 13	" 400m Hurdles
Hayes, Robert L.	702	M	183.0	86.0	'42 • 12 • 20	" 100m, 4X100m
Herman, Paul Irvin	767	M	188.0	80.0	'41 • 3 • 7	" Decathlon
Hodge, Russell Arden	763	M	191.0	100.0	'39 • 9 • 12	" Decathlon
Hopkins, Gayle Patric	741	M	187.0	75.0	'41 • 11 • 7	" Long Jump
Jackson, Trenton	703	M	183.0	80.0	'42 • 2 • 28	" 100m, 4X100m
Jones, Hayes Wendell	724	M	178.0	73.0	'38 • 8 • 4	" 110m Hurdles
Knott, Sandra Phyllis	222	F	170.0	55.0	'37 • 10 • 9	" 800m
Laird, Ronald Owen	760	M	186.0	75.0	'38 • 5 • 31	" 20km Road Walk
Larrabee, Michael D.	709	M	186.0	77.0	'38 • 12 • 2	" 400m, 4X400m
Larrieu, Gilbert Ronald	720	M	165.0	55.0	'37 • 5 • 29	" 10000m
Lewis, Theron Bernard	733	M	187.0	73.0	'44 • 7 • 10	" 4X400m
Lindgren, Gerald Paul	721	M	168.0	55.0	'48 • 3 • 9	" 10000m
Linogren, Harold Blaine	725	M	191.0	91.0	'39 • 6 • 26	" 110m Hurdles
Long, Dallas Crutcher	746	M	193.0	118.0	'40 • 6 • 13	" Shot Put
Luck, James Edmund	728	M	180.0	73.0	'40 • 7 • 11	" 400m Hurdles
Macdonald, Bruce Duncan	764	M	180.0	75.0	'27 • 10 • 22	" 50km Road Walk
Matson, James Randel	747	M	200.0	109.0	'45 • 5 • 5	" Shot Put
McArdle, Peter Joseph	759	M	173.0	57.0	'30 • 3 • 22	" Marathon

NAME NOM	NO. NO.	SEX SEXE	HEIGHT HAUTEUR	WEIGHT POIDS	DATE OF BIRTH DATE DE NAISSANCE	EVENT EPREUVE
McCarthy, Christopher	765	M	183.0	68.0	'31 • 6 • 21	Athletics Athlétisme
McGuire, Edith Marie	216	F	173.0	59.0	'44 • 6 • 3	"
Mills, William M.	722	M	180.0	70.0	'38 • 6 • 30	"
Montgomery, Eleanor Inez	228	F	174.0	59.0	'46 • 11 • 13	"
Moore, Oscar W. Jr.	718	M	175.0	59.0	'38 • 3 • 31	"
Mortland, John Eggert	761	M	180.0	61.0	'35 • 1 • 23	"
O'Brien, W. Parry Jr.	748	M	192.0	114.0	'32 • 1 • 28	"
O'Hara, Tom Martin	715	M	175.0	59.0	'42 • 5 • 7	"
O'Neal, Leahseneth	224	F	169.0	63.0	'44 • 3 • 30	"
Oerter, Alfred A. Jr.	749	M	193.0	118.0	'36 • 9 • 19	"
Pemelton, Billy Gene	738	M	183.0	75.0	'41 • 9 • 5	"
Pender, Melvin	704	M	165.0	68.0	'37 • 10 • 31	"
Pennel, John Thomas	739	M	178.0	75.0	'40 • 7 • 25	"
Rambo, John Barnett	735	M	201.0	91.0	'43 • 8 • 9	"
Red, Walter Edward	753	M	191.0	91.0	'42 • 3 • 6	"
Ryun, James Ronald	716	M	188.0	68.0	'47 • 4 • 29	"
Schul, Robert Keyser	719	M	184.0	66.0	'37 • 4 • 28	"
Sharpe, William John	745	M	183.0	73.0	'32 • 1 • 23	"
Sherrard, Cherrie	225	F	184.0	63.0	'38 • 8 • 25	"
Shinnick, Phillip Kent	742	M	191.0	82.0	'43 • 4 • 21	"
Siebert, Jerome Francis	713	M	186.0	77.0	'38 • 10 • 6	"
Silvester, L. Jay	750	M	189.0	105.0	'37 • 8 • 27	"
Smith, Janell L.	221	F	169.0	54.0	'47 • 5 • 3	"
Stebbins, Richard Vaughn	707	M	180.0	68.0	'45 • 6 • 14	"
Thomas, John Curtis	736	M	196.0	89.0	'41 • 3 • 3	"
Thompson, Deborah Ann	220	F	170.0	57.0	'47 • 5 • 5	"
Tipton, Leslie Eugene	754	M	193.0	93.0	'42 • 3 • 19	"
Tyus, Wyoma	217	F	170.0	61.0	'45 • 8 • 29	"
Watson, Martha Rae	231	F	163.0	57.0	'46 • 8 • 19	"
Weill, David Lawson	751	M	201.0	120.0	'41 • 10 • 25	"
White, Marilyn Elaine	218	F	161.0	52.0	'44 • 10 • 17	"
White, Willye B.	226	F	163.0	59.0	'39 • 11 • 31	"
Williams, Ulis C.	710	M	186.0	75.0	'41 • 10 • 24	"
Winslow, Billee Patricia	235	F	180.0	75.0	'43 • 9 • 1	"
Young, George L.	730	M	175.0	68.0	'37 • 7 • 24	"
Zinn, Ronald Lloyd	762	M	183.0	68.0	'39 • 5 • 10	"
Zwolak, Victor A.	731	M	175.0	64.0	'38 • 11 • 30	"
Amlong, Joseph Brian		M	186.0	86.0	'36 • 12 • 17	Rowing Aviron
Amlong, Thomas Kennedy		M	186.0	91.0	'35 • 6 • 15	"
Budd, Harold Boyce Jr.		M	191.0	93.0	'39 • 1 • 4	"
Clark, Emory Wendell		M	193.0	91.0	'38 • 3 • 23	"
Cromwell, Seymour Legrand		M	193.0	89.0	'34 • 2 • 17	"
Cwiklinski, Stanley F.		M	189.0	86.0	'43 • 7 • 25	"
Donovan, William Washman		M	186.0	73.0	'39 • 1 • 6	"
Durbrow, Philip Marshall		M	191.0	86.0	'40 • 10 • 27	"
Edmonds, James Stuart		M	191.0	84.0	'38 • 6 • 4	"
Ferry, Edward Payson		M	193.0	89.0	'41 • 6 • 18	"
Findlay, Conn Francis		M	198.0	93.0	'30 • 4 • 26	"
Foley, Hugh Miller		M	191.0	86.0	'44 • 3 • 3	"
Gunderson, Paul Einar		M	193.0	86.0	'43 • 5 • 21	"
Johnson, Philip Anthony		M	191.0	84.0	'40 • 11 • 16	"
Knecht, William Joseph		M	183.0	91.0	'30 • 3 • 10	"
Lea, Robert Cabeen III		M	178.0	77.0	'42 • 3 • 23	"
Lyon, Richard Avery		M	191.0	84.0	'39 • 9 • 7	"
Mitchell, Kent		M	174.0	52.0	'39 • 3 • 29	"
Mittet, Theodore Peder		M	193.0	84.0	'41 • 12 • 23	"
Nash, Ted Allison		M	193.0	89.0	'32 • 10 • 29	"
Picard, Geoffrey William		M	192.0	86.0	'43 • 3 • 20	"
Pollock, Harry Winslow		M	196.0	86.0	'42 • 7 • 16	"

NAME NOM	NO. NO.	SEX SEXE	HEIGHT HAUTEUR	WEIGHT POIDS	DATE OF BIRTH DATE DE NAISSANCE	EVENT EPREUVE
Pollock, Thomas Elmer		M	196.0	89.0	'43 • 7 • 24	Rowing Aviron
Riley, Chester Herbert		M	188.0	90.0	'40 • 1 • 26	"
Schwarz, Robert Debois		M	192.0	82.0	'42 • 3 • 16	"
Spero, Donald M.		M	188.0	86.0	'39 • 8 • 9	"
Storm, James Eugene		M	202.0	95.0	'41 • 2 • 2	"
Stowe, William Arthur		M	191.0	89.0	'40 • 3 • 23	"
Tew, James Dinsmore		M	189.0	84.0	'44 • 10 • 29	"
Washburn, Edward Hall		M	168.0	54.0	'42 • 9 • 25	"
Zimonyi, Robert		M	170.0	52.0	'18 • 4 • 18	"
Barnes, Jim	4	M	203.0	109.0	'41 • 4 • 13	Basket-Ball
Bradley, William Warren	5	M	196.0	93.0	'43 • 7 • 28	"
Brown, Lawrence Harvey	6	M	178.0	73.0	'40 • 9 • 14	"
Caldwell, Joe Louis	7	M	196.0	89.0	'41 • 11 • 1	"
Counts, Mel Grant	8	M	213.0	102.0	'41 • 10 • 16	"
Davies, Richard Allen	9	M	186.0	80.0	'36 • 1 • 21	"
Hazzard, Walter	10	M	191.0	91.0	'42 • 4 • 15	"
Jackson, Lucious Brown	11	M	206.0	107.0	'41 • 10 • 31	"
McCaffrey, John Paul	12	M	198.0	98.0	'38 • 1 • 24	"
Mullins, Jeffry Vincent	13	M	193.0	86.0	'42 • 3 • 19	"
Shipp, Jerry Franklin	14	M	198.0	93.0	'35 • 9 • 27	"
Wilson, George	15	M	203.0	95.0	'42 • 5 • 9	"
Brown, Charles	264	M	168.0	59.0	'39 • 7 • 28	Boxing Boxe
Carmody, Robert John	262	M	158.0	51.0	'38 • 9 • 4	"
Christopherson, Robert H.	270	M	183.0	79.5	'36 • 10 • 7	"
Ellis, Charles Ray	266	M	175.0	63.0	'43 • 6 • 29	"
Frazier, Joseph	271	M	180.0	89.0	'44 • 1 • 12	"
Frilot, Maurice Emmett	267	M	175.0	68.0	'40 • 11 • 29	"
Gibson, Tolman Jr.	268	M	180.0	70.0	'42 • 4 • 17	"
Harris, Ronald Allen	265	M	169.0	60.0	'47 • 2 • 8	"
Johnson, Louis Henry	263	M	168.0	65.0	'38 • 11 • 4	"
Rosette, James Columbus	269	M	180.0	75.0	'38 • 7 • 9	"
Dronzek, Joseph Francis	138	M	188.0	77.0	'40 • 7 • 14	Canoeing Canotage
Fox, Francine Anne	139	F	170.0	66.0	'49 • 3 • 16	"
Grigoleit, Gert Rudolf	140	M	191.0	82.0	'27 • 7 • 12	"
Jewell, William Harvey	141	M	188.0	80.0	'41 • 7 • 14	"
Jones, Marcia Ingram	142	F	168.0	61.0	'41 • 7 • 13	"
O'Rourke, James J. Jr.	143	M	180.0	80.0	'42 • 5 • 6	"
Perrier, Gloriane Aurore	144	F	178.0	66.0	'29 • 3 • 21	"
Ralphs, Tony	145	M	.	.		"
Richards, Walter Charles	146	M	183.0	80.0	'42 • 3 • 14	"
Smoke, William Archibald	147	M	180.0	68.0	'38 • 1 • 2	"
Van Valkenburgh, D. A.	148	M	183.0	70.0	'44 • 8 • 16	"
Allen, Michael Gary	152	M	178.0	68.0	'35 • 5 • 20	Cycling Cyclisme
Allis, John Cotton	151	M	173.0	68.0	'42 • 5 • 31	"
Castilloux, J. Raymond	161	M	175.0	70.0	'44 • 11 • 23	"
Chowen, Wesley John	162	M	186.0	70.0	'39 • 5 • 25	"
Cutting, Harry Warren III	164	M	184.0	73.0	'46 • 6 • 9	"
Disney, Jack	159	M	172.0	68.0	'30 • 6 • 15	"
Grieco, Alan	162	M	180.0	75.0	'46 • 5 • 7	"
Hiltner, Michael Beckwith	160	M	167.0	61.0	'41 • 3 • 7	"
Kund, William	161	M	186.0	80.0	'46 • 3 • 30	"
Martin, Oliver	156	M	180.0	64.0	'46 • 7 • 10	"
Montemage, Thomas Ronald	163	M	175.0	73.0	'27 • 1 • 21	"
Mountford, Tim Howard	160	M	170.0	66.0	'46 • 4 • 2	"
Nelsen, Donald Robert	157	M	173.0	66.0	'44 • 9 • 4	"
Simes, Jackie Weston III	163	M	172.0	70.0	'42 • 11 • 20	"
Uhrlass, Arnold H.	158	M	183.0	77.0	'31 • 10 • 19	"
Wolf, Hans Joachim	155	M	188.0	75.0	'40 • 9 • 8	"
Anastasi, Lawrence Joseph	245	M	186.0	77.0	'34 • 9 • 6	Fencing Escrime

NAME NOM	NO. NO.	SEX SEXE	HEIGHT HAUTEUR	WEIGHT POIDS	DATE OF BIRTH DATE DE NAISSANCE	EVENT EPREUVE	
Angell, Tommy Ferrell	240	F	158.0	57.0	'34 • 5 • 6	Fencing Escrime	Foil Ind., Team
Anger, Frank David	249	M	191.0	77.0	'39 • 9 • 24	"	Epee Ind., Team
Axelrod, Albert	241	M	183.0	84.0	'21 • 2 • 12	"	Foil Ind., Team
Bleamaster, Leslie F.	248	M	178.0	70.0	'36 • 4 • 20	"	Epee Team
Blum, Robert Max	254	M	175.0	77.0	'28 • 11 • 24	"	Sabre Team
Cohen, Herbert Morris	242	M	173.0	70.0	'40 • 6 • 7	"	Foil Ind., Team
Drungis, Anne Mary	239	F	173.0	66.0	'31 • 10 • 11	"	Foil Team
Glazer, Eugene Gerson	244	M	178.0	75.0	'39 • 11 • 24	"	Foil Team
Hamori, Eugene	251	M	183.0	77.0	'33 • 8 • 27	"	Sabre Ind., Team
Keresztes, Attila	250	M	183.0	82.0	'28 • 1 • 18	"	Sabre Ind., Team
King, Harriet	238	F	165.0	59.0	'35 • 9 • 22	"	Foil Ind., Team
Micahnik, David Morris	247	M	186.0	80.0	'38 • 11 • 5	"	Epee Ind., Team
Morales, Alfonso Hector	253	M	188.0	77.0	'37 • 5 • 19	"	Sabre Team
O'Connor, Denise C.	237	F	175.0	66.0	'35 • 5 • 18	"	Foil Team
Orley, S. Thomas	252	M	183.0	82.0	'34 • 2 • 21	"	Sabre Ind., Team
Pesthy, Paul Karoly	246	M	180.0	68.0	'38 • 3 • 25	"	Epee Ind., Team
Richards, Edwin Allan	243	M	188.0	66.0	'29 • 11 • 3	"	Foil Ind., Team
Romary, Janice-Lee	236	F	184.0	61.0	'28 • 8 • 6	"	Foil Ind., Team
Banner, Larry Shyres	111	M	180.0	69.0	'36 • 6 • 11	Gymnastics Gymnastique	
Barak, Ronald S	112	M	170.0	64.0	'43 • 6 • 7	"	
Corrigan, Kathleen M.	47	F	160.0	50.0	'45 • 3 • 3	"	
Fuchs, Doris Gudrun	41	F	153.0	50.0	'39 • 6 • 11	"	
Grossfeld, Muriel Davis	42	F	163.0	50.0	'40 • 10 • 7	"	
McClements, D. E.	43	F	153.0	46.0	'44 • 12 • 31	"	
Metheny, Linda Jo	44	F	155.0	48.0	'47 • 8 • 12	"	
Mitchell, Russell Duncan	113	M	170.0	64.0	'42 • 6 • 1	"	
Sakamoto, Makoto Douglas	114	M	155.0	55.0	'47 • 4 • 8	"	
Shurlock, Arthur David	115	M	176.0	75.0	'37 • 9 • 8	"	
Speaks, Janie Lee	45	F	160.0	52.0	'48 • 6 • 8	"	
Vega, Armando	117	M	167.0	65.0	'35 • 10 • 24	"	
Walther, Marie Sue	46	F	155.0	48.0	'44 • 12 • 8	"	
Weiss, Gregor Richard	116	M	167.0	64.0	'41 • 2 • 18	"	
Berger, Isaac	54	M	159.0	60.0	'36 • 11 • 16	Weight-Lifting Haltérophilie	Feather
Cleveland, Cary Gayln	123	M	173.0	82.0	'42 • 1 • 18	"	L. Heavy
Gercy, Anthony Michael	76	M	163.0	68.0	'39 • 6 • 20	"	Light
Gubner, Gary Jay	161	M	188.0	120.0	'42 • 12 • 1	"	Heavy
March, William Frederick	141	M	175.0	91.0	'37 • 2 • 4	"	M. Heavy
Riecke, Louis George Jr.	142	M	173.0	91.0	'26 • 10 • 2	"	M. Heavy
Schemansky, Norbert	162	M	183.0	120.0	'24 • 5 • 30	"	Heavy
Bregman, James Steven		M	170.0	80.0	'41 • 11 • 17	Judo	Middle Weight
Campbell, Ben M.		M	180.0	93.0	'34 • 4 • 13	"	All Weights
Harris, George Lee		M	189.0	100.0	'33 • 1 • 15	"	Heavy Weight
Maruyama, Paul Kuniaki		M	168.0	68.0	'41 • 10 • 27	"	Light Weight
Auble, David Camillo		M	168.0	59.0	'38 • 5 • 13	Wrestling Lutte	Free S.-Bantam
Baughman, Richard Wayne		M	188.0	89.0	'41 • 1 • 4	"	Greco R.-Middle
Brand, Daniel Oliver		M	196.0	97.0	'35 • 8 • 4	"	Free S.-Middle
Burke, James Richard		M	178.0	72.0	'36 • 2 • 20	"	Greco R.-Light
Camilleri, Russell A.		M	183.0	81.0	'36 • 11 • 13	"	Greco R.-Welter
Conine, Gerald Guy		M	180.0	97.0	'39 • 12 • 2	"	Free S.-L. Heavy
Douglas, Bobby E.		M	170.0	68.0	'42 • 3 • 26	"	Free S.-Feather
Finley, Ronald Leslie		M	168.0	65.0	'40 • 12 • 10	"	Greco R.-Feather
Fitch, Andrew		M	163.0	57.0	'36 • 8 • 28	"	Greco R.-Bantam
Kristoff, Larry Dean		M	183.0	107.0	'42 • 11 • 11	"	Free S.-Heavy
Lovell, William Patrick		M	183.0	97.0	'37 • 11 • 1	"	Greco R.-L. Heavy
Pickens, Robert James		M	193.0	111.0	'43 • 2 • 2	"	Greco R.-Heavy
Ruth, Gregory Koch		M	173.0	72.0	'39 • 8 • 9	"	Free S.-Light
Simons, Elliott Gray		M	165.0	55.0	'39 • 8 • 13	"	Free S.-Fly
Tribble, Charles Edward		M	180.0	81.0	'42 • 4 • 24	"	Free S.-Welter
Wilson, John Richard		M	165.0	54.0	'33 • 11 • 19	"	Greco R.-Fly

NAME NOM	NO. NO.	SEX SEXE	HEIGHT HAUTEUR	WEIGHT POIDS	DATE OF BIRTH DATE DE NAISSANCE	EVENT EPREUVE
Allsup, Lynne Marie		F	168.0	59.0	'49 • 1 • 2	Swimming and Diving Natation et Plongeon
Anderson, Wayne Robert		M	175.0	70.0	'45 • 4 • 4	"
Andreasen, Larry Edwin		M	163.0	61.0	'45 • 11 • 13	"
Austin, Michael Mackay		M	187.0	89.0	'43 • 8 • 26	"
Bennett, Robert Earl		M	186.0	84.0	'43 • 5 • 23	"
Bricker, Erika Eloise		F	175.0	64.0	'49 • 5 • 23	"
Bush, Lesley Leigh		F	160.0	52.0	'47 • 9 • 17	"
Clark, Stephen Edward		M	183.0	73.0	'43 • 6 • 17	"
Collier, Jeanne Ellen		F	156.0	48.0	'46 • 5 • 15	"
Cooper, Linda Lee		F	163.0	55.0	'44 • 7 • 19	"
Craig, William Norval		M	180.0	77.0	'45 • 1 • 16	"
De Varona, Donna E.		F	168.0	61.0	'47 • 4 • 26	"
Dilley, Gary J.		M	186.0	75.0	'45 • 1 • 15	"
Duenkel, Virginia Ruth		F	170.0	61.0	'47 • 3 • 7	"
Ellis, Kathleen		F	170.0	59.0	'46 • 11 • 28	"
Farley, William Winfield		M	186.0	80.0	'44 • 11 • 10	"
Ferguson, Cathy Jean		F	173.0	61.0	'48 • 7 • 17	"
Finneran, Sharon Evans		F	161.0	50.0	'46 • 2 • 4	"
Gompf, Thomas Eugene		M	180.0	75.0	'39 • 3 • 17	"
Gorman, Francis Xavier		M	178.0	70.0	'37 • 11 • 11	"
Gossick, Sue		F	164.0	48.0	'47 • 11 • 12	"
Goyette, Cynthia Lee		F	166.0	52.0	'46 • 8 • 13	"
Graef, Jed Richard		M	198.0	91.0	'42 • 5 • 1	"
Hallock, Jeanne Courtney		F	173.0	61.0	'46 • 12 • 26	"
Harmar, Nina Adams		F	173.0	66.0	'45 • 12 • 11	"
Hazleton, Tamara Anne		F	178.0	68.0	'47 • 12 • 1	"
Iلمان, Gary Steven		M	188.0	89.0	'43 • 8 • 13	"
Jastremski, Chester A.		M	175.0	75.0	'41 • 1 • 12	"
Kolb, Claudia Anne		F	165.0	55.0	'49 • 12 • 18	"
Luken, Virgil W.		M	175.0	82.0	'42 • 9 • 12	"
Lyons, David Chandler		M	182.0	70.0	'43 • 1 • 23	"
Mann, Harold Thompson		M	186.0	77.0	'42 • 12 • 1	"
McGeagh, Richard Michael		M	191.0	84.0	'44 • 3 • 11	"
Mettler, William Roy		M	179.0	77.0	'46 • 10 • 15	"
Nelson, John Mauer		M	175.0	66.0	'48 • 6 • 8	"
Nitta, Sandra Hauka		F	154.0	52.0	'49 • 4 • 24	"
Pitt, Susan Kay		F	172.0	57.0	'48 • 6 • 18	"
Ramenofsky, Marilyn		F	169.0	61.0	'46 • 8 • 20	"
Randall, Martha Irene		F	165.0	57.0	'48 • 6 • 12	"
Reeder, Judith Anne		F	174.0	57.0	'48 • 8 • 17	"
Richardson, Walter Pierce		M	180.0	75.0	'43 • 4 • 1	"
Riker, Philip III		M	169.0	68.0	'46 • 9 • 16	"
Robie, Carl Joseph		M	179.0	70.0	'45 • 5 • 12	"
Roth, Richard William		M	184.0	84.0	'47 • 9 • 26	"
Saari, Roy Allen		M	188.0	86.0	'45 • 2 • 26	"
Schmidt, Fred Weber		M	188.0	84.0	'43 • 10 • 23	"
Schollander, D. Arthur		M	182.0	75.0	'46 • 4 • 30	"
Schulhof, Lary Alan		M	178.0	75.0	'42 • 6 • 15	"
Seidel, Kathleen		F	174.0	66.0	'50 • 3 • 8	"
Sherman, Patience Halsey		F	171.0	59.0	'46 • 9 • 20	"
Sitzberger, Kenneth R.		M	177.0	70.0	'45 • 2 • 13	"
Stickles, Terri Lee		F	178.0	68.0	'46 • 5 • 11	"
Stouder, Sharon Marie		F	173.0	61.0	'48 • 11 • 9	"
Talmage, Barbara Ellen		F	163.0	54.0	'41 • 5 • 20	"
Townsend, Robert Edward		M	193.0	89.0	'43 • 9 • 13	"
Trethewey, Tom George		M	186.0	77.0	'44 • 5 • 8	"
Vitucci, Louis Vincent		M	175.0	66.0	'40 • 12 • 14	"
Wall, Michael Allen		M	188.0	80.0	'46 • 2 • 1	"
Watson, Lillian Debra		F	173.0	62.0	'50 • 7 • 11	"

NAME NOM	NO. NO.	SEX SEXE	HEIGHT HAUTEUR	WEIGHT POIDS	DATE OF BIRTH DATE DE NAISSANCE	EVENT EPREUVE	
Webster, Robert David		M	175.0	68.0	'38 • 10 • 25	Swimming and Diving Natation et Plongeon	High Diving
Willard, Mary Patricia		F	170.0	59.0	'41 • 5 • 18	"	Springboard Diving
Kerr, James Lancefield	40	M	186.0	75.0	'40 • 8 • 17	Modern Pentathlon Pentathlon Moderne	
Kirkwood, David Arthur	41	M	183.0	82.0	'35 • 9 • 20	"	
Moore, James Warren	42	M	177.0	68.0	'35 • 2 • 20	"	
Pesthy, Paul Karoly	43	M	180.0	68.0	'38 • 3 • 25	"	
Chapot, Frank Davis		M	178.0	68.0	'34 • 2 • 24	Equestrian Sports Sport Equestre	Jumping Grand Prix
De La Tour, Patricia G.		F	165.0	43.0	'39 • 3 • 20	"	Dressage Grand Prix
Dupont, Helena Allaire		F	170.0	61.0	'39 • 7 • 6	"	Three-Day Event
Freeman, Kevin John		M	173.0	66.0	'41 • 10 • 21	"	Three-Day Event
Kusner, Kathryn Hallowell		F	162.0	48.0	'40 • 3 • 21	"	Jumping Grand Prix
Mairs, Mary Ward		F	173.0	59.0	'44 • 6 • 20	"	Dressage Grand Prix
McIntosh, Karen Stuart		F	165.0	57.0	'40 • 1 • 14	"	Dressage Grand Prix
Newberry, Anne Jessica		F	170.0	57.0	'38 • 10 • 14	"	Dressage Grand Prix
Page, Michael Owen		M	173.0	61.0	'38 • 9 • 23	"	Three-Day Event
Plumb, John Michael		M	183.0	80.0	'40 • 3 • 28	"	Three-Day Event
Steinkraus, William C.		M	180.0	68.0	'25 • 10 • 12	"	Jumping Grand Prix
Anderson, Gary Lee	303	M	183.0	68.0	'39 • 10 • 8	Shooting Tir	Free Rifle
Green, Franklin C.	307	M	170.0	82.0	'33 • 5 • 5	"	Free Pistol
Gunnarsson, Martin I.	302	M	178.0	86.0	'27 • 3 • 30	"	Free Rifle
Little, Frank	17	M	188.0	91.0	'36 • 4 • 16	"	Clay Pigeon
McMillan, William Willard	308	M	183.0	86.0	'29 • 1 • 29	"	Rapid Fire Pistol
Morris, William C. III	18	M	180.0	73.0	'39 • 6 • 27	"	Clay Pigeon
Pool, Tommy Gayle	305	M	188.0	105.0	'35 • 2 • 10	"	Small Bore-3 P., Prone
Smith, Thomas Devine III	306	M	188.0	100.0	'31 • 10 • 30	"	Free Pistol
Teague, Edwin Lee	309	M	170.0	66.0	'34 • 10 • 26	"	Rapid Fire Pistol
Wigger, Lones Wesley Jr.	304	M	170.0	82.0	'37 • 8 • 25	"	Small Bore-3 P., Prone
Bright, David Michael	8	M	193.0	84.0	'37 • 11 • 3	Volley-Ball	
Bright, Patricia Ann	9	F	159.0	48.0	'40 • 12 • 27	"	
Brown, Barry R.	12	M	196.0	86.0	'34 • 10 • 10	"	
Erickson, Keith R.	13	M	196.0	86.0	'44 • 4 • 19	"	
Gaertner, Jean K.	1	F	153.0	49.0	'38 •	"	
Galloway, Lou Sara	4	F	178.0	64.0	'42 • 1 • 7	"	
Griebenow, William Ear	7	M	192.0	82.0	'43 • 4 • 15	"	
Hammer, Richard Bernarr	9	M	188.0	80.0	'30 • 7 • 17	"	
Harwerth, Barbara Jean	12	F	175.0	66.0	'41 • 3 • 6	"	
Highland, Jacob Alapak	5	M	187.0	84.0	'32 • 2 • 23	"	
Lang, Ronald Dwayne	4	M	183.0	84.0	'37 • 2 • 5	"	
Murphy, Linda Kathleen	3	F	188.0	75.0	'43 • 9 • 3	"	
Nelson, Charles T.	10	M	183.0	82.0	'33 • 4 • 14	"	
O'Hara, Michael Futch	6	M	193.0	84.0	'32 • 9 • 15	"	
O'Rourke, Gail Patricia	2	F	172.0	75.0	'42 • 12 • 23	"	
Owen, Nancy	8	F	174.0	64.0	'43 • 5 • 2	"	
Peppler, Mary Joan	7	F	183.0	73.0	'44 • 10 • 17	"	
Perry, Mary Margaret	6	F	173.0	58.0	'43 • 1 • 3	"	
Peterson, Sharon Roberta	11	F	168.0	58.0	'42 • 11 • 27	"	
Suwara, Ernest	14	M	189.0	84.0	'45 • 3 • 15	"	
Taylor, John Franklin	11	M	188.0	86.0	'44 • 5 • 30	"	
Thomas, Verneda Estella	5	F	183.0	70.0	'36 • 6 • 21	"	
Velasco, Pedro	1	M	178.0	80.0	'37 • 4 • 6	"	
Ward, Jane Lois	10	F	171.0	64.0	'32 • 4 • 30	"	
Ashleigh, David Michael		M	183.0	75.0	'43 • 8 • 8	Water Polo	
Cole, Stanley Clark		M	186.0	81.0	'45 • 10 • 12	"	
Crawford, Ronald Emerson		M	183.0	81.0	'39 • 12 • 6	"	
Drown, Daniel Hannon		M	189.0	86.0	'42 • 10 • 24	"	
McIlroy, Charles Raymond		M	180.0	77.0	'38 • 8 • 1	"	
McIlroy, Ned Leroy		M	178.0	75.0	'39 • 7 • 26	"	
McIlroy, Paul Robert		M	178.0	75.0	'37 • 5 • 12	"	
Saari, Robert Paul		M	188.0	80.0	'48 • 6 • 7	"	

NAME NOM	NO. NO.	SEX SEXE	HEIGHT HAUTEUR	WEIGHT POIDS	DATE OF BIRTH DATE DE NAISSANCE	EVENT EPREUVE
Stransky, George Charles		M	188.0	77.0	'44 • 1 • 16	Water Polo
Van Dorp, Anton Ludwig		M	194.0	98.0	'36 • 6 • 25	"
Whitney, Ralph John		M	180.0	75.0	'36 • 10 • 30	"
Barrett, Peter Jones		M	186.0	93.0	'35 • 2 • 20	Yachting Finn
Batchelder, Joseph Laws		M	186.0	84.0	'38 • 8 • 24	" 5.5m
Bentsen, William Bruce		M	180.0	75.0	'30 • 2 • 18	" F. Dutchman
Chance, Britton Jr.		M	188.0	89.0	'40 • 6 • 12	" Reserve
Deaver, Richard Burke		M	180.0	77.0	'31 • 2 • 7	" Dragon
McNamara, John J. Jr.		M	188.0	95.0	'32 • 2 • 7	" 5.5m
Melges, Harry Clemens Jr.		M	182.0	86.0	'30 • 1 • 26	" F. Dutchman
North, Lowell Orten		M	184.0	82.0	'29 • 12 • 2	" Dragon
Rogers, Charles Sinclair		M	183.0	82.0	'37 • 6 • 1	" Dragon
Schoonmaker, James M. II		M	183.0	86.0	'33 • 6 • 10	" Reserve
Scully, Francis Paul Jr.		M	183.0	77.0	'25 • 1 • 24	" 5.5m
Sprague, Henry Ware III		M	183.0	82.0	'45 • 10 • 6	" Reserve
Stearns, Richard Irving		M	177.0	75.0	'27 • 9 • 4	" Star
Williams, Lynn Alfred III		M	189.0	93.0	'39 • 6 • 29	" Star
U.S.S.R. U.R.S.S.						
Abramov, Nikolay	692	M	164.0	59.0	'33 • 12 • 10	Athletics Athlétisme Marathon
Agapov, Gennady	698	M	181.5	76.0	'33 • 12 • 5	" 50km Road Walk
Alexeiunas, Adolf	661	M	172.0	66.5	'37 • 6 • 27	" 3000m S. C.
Anisimov, Vasily	658	M	180.0	78.0	'38 • 1 • 23	" 400m Hurdles, 4X400m
Arkipchuk, Vadim	643	M	182.0	74.0	'37 • 7 • 6	" 400m, 4X400m
Aun, Rein	701	M	188.0	81.0	'40 • 10 • 5	" Decathlon
Axonov, Victor	685	M	185.0	89.0	'41 • 7 • 26	" Javelin Throw
Baidiuk, Stepan	652	M	177.0	67.0	'41 • 11 • 28	" 5000m
Baikov, Victor	691	M	175.0	65.0	'35 • 2 • 9	" Marathon
Bakarinov, Yury	687	M	179.0	99.0	'38 • 5 • 8	" Hammer Throw
Barkovsky, Leonid	674	M	176.0	75.0	'40 • 12 • 13	" Long Jump
Beliaev, Ivan	663	M	172.0	67.0	'35 • 2 • 8	" 3000m S. C.
Belitsky, Ivan	649	M	171.0	62.0	'36 • 10 • 25	" 1500m
Bliznotsov, Gennady	669	M	190.0	90.0	'41 • 1 • 6	" Pole Vault
Bolotnikov, Piotr	653	M	173.0	64.0	'31 • 3 • 8	" 10000m
Brumel, Valery	666	M	184.0	75.0	'42 • 4 • 14	" High Jump
Bukhantsov, Kim	683	M	182.0	102.0	'31 • 11 • 25	" Discus Throw
Bulyshv, Valery	646	M	177.0	72.0	'39 • 6 • 15	" 800m, 4X400m
Bychkov, Victor	644	M	186.0	78.0	'38 • 1 • 14	" 400m, 4X400m
Bystrova, Galina	202	F	170.0	64.5	'34 • 2 • 8	" 80m Hurdles, Pentathlon
Chenchik, Taisia	205	F	175.0	74.0	'36 • 1 • 30	" High Jump
Chistiakov, Valentin	657	M	192.0	82.5	'39 • 11 • 1	" 110m Hurdles
Chuiko, Aida	207	F	161.0	53.0	'36 • 11 • 24	" Long Jump
Demin, Sergey	670	M	183.0	77.0	'43 • 12 • 18	" Pole Vault
Dutov, Nikolay	651	M	175.0	69.0	'38 • 7 • 19	" 5000m, 10000m
Erik, Laine	199	F	167.0	65.0	'42 • 4 • 21	" 800m
Fedoseev, Oleg	677	M	186.0	82.0	'36 • 6 • 4	" Triple Jump
Feld, Igor	671	M	182.0	74.0	'41 • 2 • 21	" Pole Vault
Frolov, Valery	665	M	176.0	73.5	'41 • 6 • 24	" 4X400m
Gaida, Galina	195	F	166.0	63.7	'36 • 11 • 28	" 100m, 200m, 4X100m
Golubnichy, Vladimir	694	M	179.0	78.0	'36 • 6 • 2	" 20km Road Walk
Gorchakova, Elena	213	F	164.0	68.0	'33 • 5 • 17	" Javelin Throw
Itkina, Maria	197	F	166.0	62.0	'32 • 11 • 3	" 200m, 400m, 4X100m
Ivanov, Leonid	654	M	173.0	67.0	'37 • 8 • 25	" 10000m
Kaledene, Biruta	214	F	173.0	82.0	'33 • 10 • 2	" Javelin Throw
Karasiov, Nikolay	680	M	182.0	110.0	'39 • 11 • 29	" Shot Put
Khrolovich, Boris	695	M	178.0	70.0	'36 • 4 • 16	" 20km Road Walk
Klim, Romuald	688	M	187.0	103.0	'33 • 5 • 25	" Hammer Throw
Kompaneets, Victor	682	M	180.5	103.0	'37 • 3 • 21	" Discus Throw
Kontarev, Alexandr	656	M	180.0	77.0	'38 • 2 • 18	" 110m Hurdles
Kosanov, Gusman	639	M	175.0	75.0	'35 • 5 • 25	" 100m, 4X100m

NAME NOM	NO. NO.	SEX SEXE	HEIGHT HAUTEUR	WEIGHT POIDS	DATE OF BIRTH DATE DE NAISSANCE	EVENT EPREUVE
Kostenko, Galina	206	F	170.0	64.0	'38 • 10 • 8	Athletics Athlétisme
Kravchenko, Victor	676	M	172.0	65.0	'41 • 5 • 25	"
Kreer, Vitold	675	M	181.0	71.0	'32 • 11 • 12	"
Krivosheev, Abram	647	M	181.0	72.0	'33 • 11 • 12	"
Kuklich, Imant	660	M	183.0	76.0	'38 • 3 • 26	"
Kuznetsov, Vasily	700	M	185.0	84.0	'32 • 2 • 7	"
Kuznetsov, Vladimir	686	M	185.0	82.0	'31 • 4 • 2	"
Kuznetsova, Eugenia	210	F	175.0	83.0	'36 • 1 • 1	"
Latse, Renata	193	F	174.0	65.0	'43 • 2 • 18	"
Lipnis, Victor	679	M	191.0	110.0	'33 • 12 • 6	"
Liungin, Eugeny	696	M	186.0	72.0	'38 • 8 • 8	"
Lusis, Yan	684	M	180.0	82.0	'39 • 5 • 19	"
Mikhailov, Anatoly	655	M	183.0	81.0	'36 • 9 • 14	"
Mukhanova, Vera	198	F	163.0	48.0	'37 • 9 • 24	"
Naroditsky, Lazar	662	M	170.0	61.0	'37 • 12 • 18	"
Nikulin, Yury	689	M	178.0	102.0	'31 • 1 • 8	"
Orentas, Kestutis	650	M	175.0	67.0	'39 • 3 • 15	"
Ozolin, Edvin	638	M	184.0	74.0	'39 • 2 • 12	"
Ozolina, Elvira	212	F	175.0	66.0	'39 • 10 • 8	"
Politiko, Nikolay	640	M	180.0	81.0	'37 • 2 • 6	"
Ponomariova, Nina	211	F	173.0	79.0	'29 • 4 • 27	"
Popova, Galina	194	F	165.0	56.0	'32 • 7 • 2	"
Press, Irina	201	F	168.0	74.0	'39 • 3 • 3	"
Press, Tamara	208	F	180.0	100.0	'37 • 5 • 10	"
Samotesova, Ludmila	196	F	163.0	50.0	'39 • 10 • 26	"
Savchuk, Boris	642	M	187.0	82.0	'43 • 8 • 9	"
Schelkanova, Tatyana	204	F	168.0	58.0	'37 • 4 • 18	"
Shavlakadze, Robert	668	M	186.0	82.0	'33 • 4 • 1	"
Siziakova, Maria	215	F	171.0	65.0	'36 • 9 • 3	"
Skobtsova, Zoya	200	F	165.0	61.0	'34 • 7 • 3	"
Skvortsov, Valery	667	M	186.0	80.0	'45 • 5 • 31	"
Solodov, Gennady	693	M	178.0	75.0	'34 • 10 • 6	"
Storozhenko, Mikhail	699	M	189.0	82.0	'37 • 11 • 12	"
Sverbetov, Grigory	645	M	183.0	78.0	'39 • 4 • 3	"
Talysheva, Tatyana	203	F	164.0	56.0	'37 • 10 • 15	"
Telp, Rein	648	M	189.5	74.0	'41 • 10 • 11	"
Ter-Ovanesyan, Igor	673	M	186.0	78.0	'38 • 5 • 19	"
Tikhomirov, Nikolay	690	M	180.0	68.0	'30 • 12 • 21	"
Trusenev, Vladimir	681	M	190.0	113.0	'31 • 8 • 3	"
Tuyakov, Amin	664	M	172.0	69.0	'37 • 2 • 12	"
Varanauskas, Adolf	678	M	193.5	84.0	'34 • 2 • 4	"
Vaupshas, Antanas	672	M	186.0	73.0	'36 • 5 • 20	"
Vediakov, Anatoly	697	M	177.0	69.0	'30 • 12 • 21	"
Zageris, Edvin	689	M	180.0	68.0	'43 • 5 • 10	"
Zubov, Boris	641	M	187.0	74.0	'42 • 12 • 1	"
Zybina, Galina	209	F	168.0	79.0	'31 • 1 • 22	"
Bagdonavichus, Antanas		M	188.0	86.0	'38 • 6 • 15	Rowing Aviron
Boreiko, Valentin		M	175.0	74.0	'33 • 10 • 10	"
Briedias, Yulius		M	188.0	86.5	'40 • 8 • 27	"
Dubrovsky, Boris		M	181.0	74.0	'39 • 10 • 8	"
Evseev, Vladimir		M	181.0	87.0	'39 • 1 • 22	"
Golovanov, Oleg		M	181.0	76.0	'34 • 12 • 17	"
Ivanov, Viacheslav		M	190.0	85.0	'38 • 7 • 30	"
Karla, Piatras		M	188.0	86.0	'37 • 4 • 9	"
Kuprin, Igor		M	190.0	89.0	'40 • 11 • 2	"
Kurdchenko, Vitaly		M	190.0	89.0	'40 • 9 • 23	"
Kuzmin, Boris		M	195.0	92.0	'41 • 2 • 11	"
Levitskas, Eugenius		M	182.0	82.0	'41 • 4 • 5	"
Liutkaitis, Pavilas		M	180.0	80.0	'37 • 2 • 5	"

NAME NOM	NO. NO.	SEX SEXE	HEIGHT HAUTEUR	WEIGHT POIDS	DATE OF BIRTH DATE DE NAISSANCE	EVENT EPREUVE
Lorentsson, Yury		M	161.0	52.0	'30 • 12 • 2	Rowing Aviron
Luzgin, Anatoly		M	166.0	54.0	'31 • 7 • 28	"
Mateyunas, Ionas		M	181.0	86.0	'40 • 9 • 21	"
Rakovschik, Leonid		M	195.0	91.0	'38 • 11 • 2	"
Rudakov, Igor		M	159.0	51.0	'34 • 10 • 8	"
Safronov, Nickoly		M	188.0	82.5	'40 • 5 • 8	"
Sass, Anatoly		M	187.0	88.0	'35 • 12 • 22	"
Sheveliov, Alexandr		M	184.0	78.0	'44 • 7 • 26	"
Sterlik, Vladimir		M	193.0	95.0	'40 • 10 • 15	"
Suslin, Yury		M	185.0	93.0	'35 • 5 • 19	"
Tiurin, Oleg		M	182.0	76.5	'37 • 6 • 29	"
Tkachuk, Anatoly		M	190.0	92.0	'37 • 2 • 15	"
Voitkevich, Rishard		M	174.0	72.0	'33 • 5 • 6	"
Yagelavichus, Iozanas-Al.		M	188.0	83.0	'39 • 1 • 12	"
Yukna, Zigmas		M	180.0	82.0	'35 • 7 • 13	"
Yutsis, Tselestinas		M	187.0	82.5	'39 • 1 • 18	"
Alachachian, Armenak	6	M	176.0	74.0	'30 • 12 • 25	Basket-Ball
Bagley, Nikolay	5	M	190.0	88.0	'37 • 2 • 25	"
Kalninsh, Yuris	15	M	185.0	85.0	'38 • 3 • 8	"
Khrynin, Viacheslav	8	M	182.0	60.0	'37 • 8 • 10	"
Korneev, Yury	11	M	196.0	96.0	'37 • 8 • 26	"
Krumin, Yan	9	M	218.0	135.0	'30 • 1 • 30	"
Lipso, Yaak	14	M	200.0	91.0	'40 • 4 • 18	"
Moseshvili, Levan	10	M	198.0	96.0	'40 • 8 • 1	"
Muizhniex, Valdis	4	M	185.0	83.0	'35 • 2 • 22	"
Petrov, Alexandr	12	M	210.0	108.0	'39 • 5 • 14	"
Travin, Alexandr	7	M	188.0	85.0	'37 • 7 • 23	"
Volnov, Gennady	13	M	200.0	92.0	'39 • 11 • 28	"
Barannikov, Vellikton	275	M	165.0	60.0	'38 • 7 • 4	Boxing Boxe
Frolov, Eugeny	276	M	175.0	64.0	'41 • 6 • 14	"
Grigoryev, Oleg	273	M	164.0	54.0	'37 • 12 • 25	"
Kiseliov, Alexey	280	M	179.0	81.0	'37 • 3 • 17	"
Lagutin, Boris	278	M	180.0	71.0	'38 • 6 • 24	"
Popenchenko, Valery	279	M	176.0	75.0	'37 • 8 • 26	"
Sorokin, Stanislav	272	M	157.0	51.0	'41 • 2 • 17	"
Stepashkin, Stanislav	274	M	163.0	57.0	'40 • 9 • 1	"
Tamulis, Richardas	277	M	177.0	68.7	'38 • 7 • 22	"
Yemelyanov, Vadim	281	M	188.0	97.0	'42 • 4 • 25	"
Chuzhikov, Nikolay	149	M	177.0	77.0	'38 • 5 • 5	Canoeing Canotage
Grishin, Anatoly	150	M	181.0	87.0	'39 • 7 • 8	"
Gruzintseva, Nina	151	F	168.0	70.0	'34 • 4 • 7	"
Ionov, Viacheslav	152	M	190.0	89.0	'40 • 6 • 26	"
Kalugin, Erik	153	M	172.0	70.0	'37 • 7 • 26	"
Khasanov, Ibragim	154	M	174.0	74.0	'37 • 11 • 4	"
Khimich, Andrey	155	M	174.0	76.0	'37 • 12 • 14	"
Khvedosiuk, Ludmila	156	F	164.0	69.0	'36 • 1 • 14	"
Morozov, Vladimir	157	M	181.0	84.0	'40 • 3 • 4	"
Oschepkov, Stepan	158	M	175.0	82.0	'34 • 1 • 9	"
Peniaev, Eugeny	159	M	186.0	80.0	'42 • 5 • 16	"
Pisarev, Igor	160	M	178.0	79.0	'31 • 2 • 19	"
Seredina, Antonina	161	F	165.0	68.0	'30 • 12 • 23	"
Shubina, Maria	162	F	166.5	69.0	'30 • 5 • 8	"
Zamotin, Mikhail	163	M	176.0	74.0	'37 • 11 • 14	"
Belgart, Arnold	165	M	186.0	83.0	'37 • 1 • 29	Cycling Cyclisme
Bodniex, Imant	169	M	173.0	77.0	'41 • 5 • 20	"
Khitrov, Valery	171	M	172.5	74.0	'41 • 4 • 16	"
Kolumbet, Leonid	166	M	181.0	79.0	'37 • 10 • 14	"
Latsis, Zintars		M	.	.	'40 • 5 • 18	"
Logunov, Victor	170	M	176.0	75.0	'44 • 7 • 21	"

Eight, With Cox
Four, With Cox
Four, Without Cox
Pair, With Cox
Pair, With Cox
Pair, With Cox
Four, Without Cox, Four,
With Cox
Eight, With Cox
Eight, With Cox
Eight, With Cox
Double Sculls
Four, With Cox
Eight, With Cox
Eight, With Cox
Eight, With Cox
Four, Without Cox
Light
L. Welter
Bantam
L. Heavy
L. Middle
Middle
Fly
Feather
Welter
Heavy
Kayak 4
Kayak 4
Kayak 2
Kayak 4
Kayak 2
Kayak 2
Canadian 2
Kayak 1
Kayak 4
Canadian 2
Canadian 1
Kayak 1
Kayak 2
Reserve
Reserve
Team Pursuit
Tandem Sprint
Scratch Sprint
Team Pursuit
Team Pursuit
1000m T. T., Tandem Sprint

NAME NOM	NO. NO.	SEX SEXE	HEIGHT HAUTEUR	WEIGHT POIDS	DATE OF BIRTH DATE DE NAISSANCE	EVENT EPREUVE	
Melikhov, Yury	164	M	179.0	81.0	'37 • 4 • 1	Cycling Cyclisme	Road Ind., Team T. T.
Moskvin, Stanislav	167	M	184.0	76.0	'39 • 1 • 19	"	Ind., Team Pursuit
Olizarenko, Anatoly	165	M	176.0	72.0	'36 • 9 • 25	"	Road Ind., Team T. T.
Petrov, Alexey	166	M	179.0	77.0	'37 • 3 • 22	"	Road Ind., Team T. T.
Pkhakadze, Omar	172	M	183.0	90.0	'44 • 8 • 12	"	Scratch Sprint
Saidkhuzhin, Gainan	167	M	173.0	71.0	'37 • 6 • 30	"	Road Ind., Team T. T.
Tereschenkov, Sergey	168	M	178.0	80.0	'38 • 4 • 27	"	Team Pursuit
Asatiani, Nugzar	270	M	171.0	73.0	'37 • 7 • 16	Fencing Escrime	Sabre Team
Gorokhova, Galina	255	F	169.0	64.0	'38 • 8 • 31	"	Foil Ind., Team
Khabarov, Bruno	265	M	188.0	77.0	'39 • 4 • 30	"	Epee Ind.
Kostava, Guram	269	M	180.0	72.0	'37 • 6 • 18	"	Epee Ind., Team
Kriss, Grigory	266	M	175.0	69.0	'40 • 12 • 24	"	Epee Ind., Team
Mavlikhanov, Umar	271	M	179.0	78.0	'37 • 9 • 24	"	Sabre Ind., Team
Melnikov, Boris	274	M	175.0	68.0	'38 • 5 • 16	"	Sabre Team
Midler, Mark	260	M	176.0	76.0	'31 • 9 • 24	"	Foil Ind., Team
Nikarchikov, A.		M	.	.		"	Epee Team
Prudskova, Valentina	258	F	159.0	52.0	'38 • 12 • 27	"	Foil Ind., Team
Rakita, Mark	272	M	179.0	75.0	'38 • 7 • 22	"	Sabre Ind., Team
Rastvorova, Valentina	256	F	167.0	64.0	'33 • 6 • 17	"	Foil Ind., Team
Rylsky, Yakov	273	M	175.0	74.0	'28 • 10 • 25	"	Sabre Ind., Team
Samusenko, Tatyana	257	F	161.0	57.0	'38 • 2 • 2	"	Foil Team
Sharov, Yury	261	M	171.0	69.0	'39 • 4 • 22	"	Foil Team
Shishova, Ludmila	259	F	159.0	58.0	'40 • 6 • 1	"	Foil Team
Sisikin, Yuriy	264	M	177.0	69.0	'37 • 5 • 15	"	Foil Ind., Team
Smoliakov, Yury	268	M	177.0	65.0	'41 • 9 • 20	"	Epee Team
Sveshnikov, Herman	263	M	175.0	75.0	'37 • 5 • 11	"	Foil Team
Zhdanovich, Victor	262	M	185.0	77.0	'38 • 1 • 27	"	Foil Ind., Team
Astakhova, Polina	23	F	167.0	56.0	'36 • 10 • 30	Gymnastics Gymnastique	
Diomidov, Sergey	205	M	172.0	70.0	'43 • 7 • 9	"	
Gromova, Ludmila	27	F	157.0	51.5	'42 • 11 • 4	"	
Latynina, Larisa	21	F	163.0	52.0	'34 • 12 • 27	"	
Leontyev, Victor	206	M	168.0	63.0	'40 • 4 • 27	"	
Lisitsky, Victor	203	M	169.0	65.0	'39 • 10 • 18	"	
Manina, Tamara	24	F	162.0	56.0	'34 • 9 • 5	"	
Muratova, Sofia	22	F	160.0	52.0	'29 • 7 • 13	"	
Shakhlin, Boris	201	M	172.0	70.0	'32 • 1 • 27	"	
Titov, Yury	202	M	169.0	67.0	'35 • 11 • 27	"	
Tsapenko, Yury	204	M	164.0	59.0	'38 • 7 • 25	"	
Volchetskaya, Elena	25	F	155.0	52.0	'44 • 12 • 4	"	
Voronin, Mikhail	207	M	170.0	65.0	'45 • 3 • 26	"	
Zamotailova, Tamara	26	F	158.0	47.0	'39 • 5 • 11	"	
Golovanov, Vladimir	143	M	172.0	90.0	'38 • 11 • 29	Weight-Lifting Haltérophilie	M. Heavy
Kaplunov, Vladimir	77	M	160.0	69.0	'33 • 3 • 2	"	Light
Kurentsov, Victor	98	M	163.0	74.0	'41 • 4 • 5	"	Middle
Plyukfeider, Rudolf	124	M	172.0	83.0	'28 • 9 • 6	"	L. Heavy
Vakhonin, Alexey	30	M	156.0	58.0	'35 • 3 • 18	"	Bantam
Vlasov, Yury	168	M	186.0	131.0	'35 • 12 • 5	"	Heavy
Zhabotinsky, Leonid	164	M	190.0	157.0	'38 • 1 • 28	"	Heavy
Bogolubov, Aron		M	172.0	70.0	'38 • 12 • 30	Judo	Light Weight
Chikviladze, Parnaoz		M	184.0	104.0	'41 • 4 • 14	"	Heavy Weight
Kiknadze, Anzor		M	182.0	105.0	'34 • 3 • 26	"	Heavy Weight
Stepanov, Oleg		M	175.0	69.0	'39 • 12 • 10	"	Light Weight
Abashidze, Rostom		M	188.0	97.0	'35 • 2 • 23	Wrestling Lutte	Greco R.-L. Heavy
Aliev, Ali		M	154.5	57.0	'37 • 11 • 29	"	Free S.-Fly
Beriashvili, Zarbegi		M	172.0	72.0	'39 • 9 • 10	"	Free S.-Light
Gvantseladze, David		M	167.0	73.0	'37 • 3 • 28	"	Greco R.-Light
Ibragimov, Aidyn Ali Ogly		M	163.0	60.0	'38 • 9 • 17	"	Free S.-Bantam
Ivanitsky, Alexandr		M	189.0	106.0	'37 • 12 • 10	"	Free S.-Heavy
Khokhashvili, Nodar		M	168.0	67.5	'40 • 9 • 28	"	Free S.-Feather

NAME NOM	NO. NO.	SEX SEXE	HEIGHT HAUTEUR	WEIGHT POIDS	DATE OF BIRTH DATE DE NAISSANCE	EVENT EPREUVE
Kolesov, Anatoly		M	174.0	80.0	'38 • 1 • 18	Wrestling Lutte
Lomidze, Shota		M	172.0	90.0	'36 • 1 • 20	"
Medved, Alexandr		M	187.0	97.0	'37 • 9 • 16	"
Olenik, Valentin		M	184.0	87.0	'39 • 8 • 18	"
Roschin, Anatoly		M	191.0	122.0	'32 • 8 • 10	"
Rurua, Roman		M	165.0	63.0	'42 • 11 • 25	"
Sagaradze, Guliko		M	168.0	78.0	'39 • 3 • 21	"
Sayadov, Armais		M	152.0	52.0	'37 • 10 • 18	"
Trostiansky, Vladlen		M	156.0	60.0	'35 • 1 • 26	"
Alekseeva, Galina		F	156.0	49.5	'46 • 11 • 27	Swimming and Diving Natation et Plongeoins
Anokhina, Elena		F	154.0	51.8	'47 • 1 • 17	"
Babanina, Svetlana		F	172.0	66.0	'43 • 2 • 4	"
Baklanova, Vera		F	160.0	56.5	'47 • 6 • 25	"
Belits-Heiman, Semen		M	186.0	73.0	'45 • 2 • 16	"
Berezin, Vladimir		M	186.0	83.5	'41 • 1 • 19	"
Bystrova, Natalya		F	175.0	66.5	'47 • 6 • 23	"
Deviatova, Tatiana		F	164.0	59.0	'48 • 9 • 19	"
Djeneeva, Tatiana		F	160.0	55.0	'46 • 10 • 4	"
Fedosova, Tamara		F	162.0	56.0	'46 • 6 • 24	"
Fotin, Oleg		M	182.0	82.0	'45 • 7 • 19	"
Kosinsky, Vladimir		M	171.0	66.0	'45 • 2 • 26	"
Kuzmin, Valentin		M	180.0	81.0	'41 • 1 • 4	"
Kuznetsova, Natalia		F	162.0	55.0	'47 • 5 • 30	"
Lobanov, Igor		M	166.5	59.5	'46 • 9 • 14	"
Mazanov, Victor		M	188.0	79.0	'47 • 3 • 8	"
Mihaylova, Natalya		F	171.0	71.0	'48 • 5 • 19	"
Novikov, Eugeny		M	178.0	78.5	'45 • 2 • 1	"
Palagin, Viktor		M	163.0	58.5	'45 • 6 • 12	"
Paramonov, Alexandr		M	175.0	70.0	'42 • 3 • 13	"
Pogozhev, Viktor		M	162.0	61.0	'41 • 9 • 30	"
Poluljakh, Boris		M	175.0	68.0	'38 • 6 • 10	"
Prokopenko, Georgy		M	180.0	75.0	'37 • 2 • 21	"
Prozumenschikova, Galina		F	168.5	71.0	'48 • 11 • 26	"
Safonov, Mikhail		M	175.0	67.5	'47 • 1 • 7	"
Savelieva, Tatiana		F	162.0	56.0	'47 • 5 • 22	"
Semchenkov, Victor		M	180.0	87.0	'42 • 12 • 6	"
Shuvalov, Vladimir		M	181.0	72.5	'46 • 10 • 3	"
Sumtsov, Yury		M	178.0	77.0	'44 • 9 • 4	"
Tutakaev, Alexandr		M	175.0	70.0	'43 • 9 • 10	"
Ustinova, Natalya		F	164.0	62.5	'44 • 12 • 22	"
Vasin, Vladimir		M	171.0	65.0	'47 • 10 • 12	"
Yakovieva, Valentina		F	163.0	66.0	'47 • 1 • 18	"
Mineev, Victor	44	M	185.0	82.0	'37 • 5 • 18	Modern Pentathlon Pentathlon Moderne
Mokeev, Albert	45	M	185.0	80.0	'36 • 1 • 4	"
Novikov, Igor	46	M	183.0	78.0	'29 • 10 • 19	"
Pichuzhkin, Valery	47	M	180.0	71.0	'40 • 11 • 12	"
Deev, Pavel		M	170.0	62.0	'42 • 1 • 2	Equestrian Sports Sport Equestre
Favorsky, Andrey		M	173.0	62.0	'29 • 1 • 1	"
Filatov, Sergey		M	172.0	82.0	'26 • 9 • 25	"
Gaziumov, Herman		M	180.0	76.0	'36 • 2 • 16	"
Kalita, Ivan		M	166.0	62.5	'27 • 1 • 14	"
Kizimov, Ivan		M	170.0	72.0	'28 • 4 • 28	"
Konkov, Boris		M	172.0	67.0	'37 • 12 • 15	"
Minakov, Yury		M	170.0	70.0	'32 • 2 • 25	"
Mursalimov, Saibattal		M	168.0	66.0	'30 • 2 • 20	"
Purtov, Alexandr		M	168.0	68.0	'35 • 10 • 27	"
Semionov, Ivan		M	173.0	67.0	'36 • 1 • 25	"
Bakalov, Igor	316	M	184.0	69.0	'39 • 12 • 9	Shooting Tir
Chilian, Vladimir	313	M	179.0	74.0	'40 • 9 • 12	"

NAME NOM	NO. NO.	SEX SEXE	HEIGHT HAUTEUR	WEIGHT POIDS	DATE OF BIRTH DATE DE NAISSANCE	EVENT EPREUVE	
Gerasimenok, Alexandr	311	M	178.0	75.0	'33 • 12 • 5	Shooting Tir	Free Rifle
Kalinin, Sergey	6	M	169.0	72.0	'26 • 12 • 23	"	Clay Pigeon
Kveliashvili, Shota	310	M	177.0	72.0	'38 • 1 • 1	"	Free Rifle
Rasskazov, Evgeniy	314	M	180.0	73.0	'41 • 10 • 21	"	Free Pistol
Senichev, Pavel	7	M	178.0	80.0	'24 • 6 • 10	"	Clay Pigeon
Shamburkin, Victor	312	M	172.0	76.5	'31 • 10 • 12	"	Small Bore-3 P., Prone
Udachin, Albert	315	M	182.0	81.0	'41 • 7 • 24	"	Free Pistol
Zabelin, Alexandr	317	M	168.0	74.0	'31 • 12 • 6	"	Rapid Fire Pistol
Abramova, Nelly	5	F	171.0	60.0	'40 • 8 • 18	Volley-Ball	
Biltauer, Astra	2	F	168.0	64.0	'44 • 10 • 9	"	
Bugaenkov, Ivan	9	M	183.0	82.5	'38 • 2 • 18	"	
Buldakova, Ludmila	4	F	172.0	67.0	'38 • 5 • 25	"	
Burobin, Nikolay	10	M	181.0	82.0	'37 • 5 • 25	"	
Chesnokov, Yury	1	M	189.0	88.0	'33 • 1 • 22	"	
Gureeva, Ludmila	12	F	184.0	75.0	'43 • 2 • 12	"	
Kacharava, Vazha	5	M	186.0	85.0	'37 • 1 • 2	"	
Kalachikhin, Valery	11	M	176.0	80.0	'39 • 5 • 20	"	
Kamenek, Valentina	7	F	170.0	69.0	'43 • 5 • 17	"	
Katusheva, Marita	9	F	174.0	70.0	'38 • 4 • 19	"	
Kovalenko, Vitaly	7	M	185.0	82.5	'34 • 3 • 17	"	
Ljugailo, Stanislav	6	M	183.0	82.0	'38 • 1 • 1	"	
Lukanina, Ninel	3	F	171.0	67.0	'37 • 9 • 18	"	
Mishak, Valentina	11	F	182.0	70.0	'42 • 1 • 16	"	
Mondzolevsky, Georgy	12	M	171.0	73.5	'34 • 1 • 26	"	
Poyarkov, Yury	8	M	185.0	83.0	'37 • 2 • 10	"	
Roschina, Tatyana	10	F	174.0	70.0	'41 • 6 • 23	"	
Ryskal, Inna	8	F	174.0	72.0	'44 • 6 • 15	"	
Ryzhova, Antonina	1	F	164.0	64.0	'34 • 7 • 5	"	
Sibiriakov, Eduard	3	M	197.0	101.0	'41 • 11 • 27	"	
Tikhonina, Tamara	6	F	171.0	74.0	'34 • 2 • 22	"	
Vengerovsky, Yury	2	M	180.5	79.0	'38 • 10 • 26	"	
Voskoboinikov, Dmitry	4	M	186.0	90.0	'41 • 3 • 6	"	
Ageev, Victor		M	184.0	83.0	'36 • 4 • 29	Water Polo	
Bortkevich, Zenon		M	179.0	80.0	'37 • 5 • 29	"	
Grabovsky, Igor		M	190.0	88.0	'41 • 9 • 2	"	
Grishin, Boris		M	189.0	85.0	'38 • 1 • 4	"	
Kalashnikov, Nikolay		M	175.0	71.0	'40 • 10 • 11	"	
Kuznetsov, Nicolay		M	179.0	74.0	'31 • 4 • 25	"	
Kuznetsov, Vladimir		M	177.0	79.0	'37 • 6 • 30	"	
Osipov, Leonid		M	187.0	86.0	'43 • 2 • 6	"	
Popov, Boris		M	181.0	79.0	'41 • 3 • 21	"	
Semionov, Vladimir		M	185.0	81.0	'38 • 5 • 10	"	
Yegorov, Eduard		M	187.0	81.0	'40 • 2 • 9	"	
Alexandrov, Konstantin		M	180.0	94.0	'20 • 7 • 7	Yachting	5.5m
Alexeev, Lev		M	172.0	70.0	'26 • 4 • 18	"	Dragon
Chuchelov, Alexandr		M	183.0	83.0	'33 • 4 • 26	"	Finn
Mankin, Valentin		M	180.0	85.0	'38 • 8 • 19	"	Reserve
Melgunov, Konstantin		M	176.0	71.0	'26 • 12 • 18	"	5.5m
Mitnitsky, Leonar		M	172.0	75.0	'26 • 9 • 19	"	Reserve
Nikolin, Valery		M	172.0	71.0	'39 • 12 • 14	"	Dragon
Pilchin, Victor		M	178.0	81.0	'40 • 4 • 6	"	F. Dutchman
Pinegin, Timur		M	164.0	82.0	'27 • 6 • 12	"	Star
Shavrin, Yury		M	183.0	73.0	'24 • 9 • 25	"	Dragon
Sheikovnikov, Alexandr		M	177.0	76.0	'37 • 7 • 30	"	F. Dutchman
Shutkov, Fiodor		M	172.0	82.0	'24 • 2 • 15	"	Star
Vasilyev, Vladimir		M	180.0	86.0	'35 • 7 • 28	"	Reserve
Zamotaikin, Valentin		M	176.0	73.0	'39 • 12 • 27	"	5.5m
VENEZUELA VENEZUELA							
Castillo, Julio	778	M	.	.	'46 • 1 • 11	Athletics Athlétisme	4X400m

NAME NOM	NO. NO.	SEX SEXE	HEIGHT HAUTEUR	WEIGHT POIDS	DATE OF BIRTH DATE DE NAISSANCE	EVENT EPREUVE
Estevez, Horacio	770	M	175.0	70.0	'41 • 7 • 6	Athletics Athlétisme 100m, 4X100m
Herrera Fucil, Hortensio	772	M	175.0	69.0	'39 • 2 • 8	" 200m, 400m, 4X100m, 4X400m
Herrera, Arquimedes	769	M	178.0	76.0	'35 • 8 • 8	" 100m, 200m, 4X100m
Maldonado, Victor	773	M	182.0	70.0	'39 • 8 • 3	" 400m, 400m Hurdles, 4X400m
Murad, Lloyd	775	M	.	.	'33 • 4 • 9	" 100m, 4X100m
Pineda, Aristides	776	M	.	.	'40 • 8 • 10	" 4X400m
Planchart, Manuel	777	M	.	.	'44 • 10 • 4	" 4X400m
Romero, Rafael	774	M	.	.	'38 • 3 • 22	" 4X100m, 4X400m
Thomas, Hector	771	M	.	.	'38 • 10 • 10	" 4X100m, Decathlon
Jorge, Lugo Lugo		M	168.0	78.0	'38 • 4 • 5	Judo Middle Weight
Capriles, Teodoro		M	179.0	69.0	'45 • 2 • 17	Swimming and Diving Natation et Plongeurs 100m, 400m Free, Ind. Medley
Rockembach, Anneliese		F	168.0	64.5	'43 • 3 • 3	" 100m Free, Back
Agustin, Rangel	319	M	159.0	58.0	'25 • 5 • 5	Shooting Tir Small Bore-Prone
Edgar, Espinoza	320	M	175.0	75.0	'28 • 7 • 13	" Free Pistol
Enrico, Forcella P.	318	M	171.0	64.0	'07 • 10 • 18	" Small Bore-Prone
Jose Antonio, Chalbaud T.	321	M	172.0	83.0	'31 • 7 • 2	" Rapid Fire Pistol
Daniel, Camejo Octavio		M	167.0	68.0	'14 • 4 • 23	Yachting Star
Juan, Feld Szanto		M	186.0	83.0	'23 • 6 • 22	" Star
Karsten, Boysen Halblaub		M	187.0	76.0	'38 • 2 • 1	" Finn
VIET-NAM VIET-NAM						
Chinh, Ho Thanh	779	M	169.0	60.0	'41 • 12 • 21	Athletics Athlétisme 100m, 200m
Ly, Nguyen Van	780	M	160.0	50.0	'42 • 5 • 30	" 1500m, 5000m, Marathon
Anh, Huynh	158	M	165.0	55.0	'32 • 10 • 16	Cycling Cyclisme Road Team T. T.
Chau, Nguyen Van	173	M	166.0	61.0	'40 • 8 • 24	" Scratch Sprint, Team Pursuit
Hoa, Nguyen Van	177	M	168.0	61.0	'35 • 5 • 28	" Reserve
Khoi, Nguyen Van	168	M	165.0	51.0	'35 •	" Road Ind., Team T. T.
Nen, Tran Van	175	M	168.0	59.0	'27 • 8 • 6	" 1000m T. T., Ind., Team Pursuit,
Ngan, Nguyen Van	174	M	160.0	51.0	'43 • 9 • 20	" Road Ind., Team T. T., Team Pursuit, Road Ind., Team T. T.
Sau, Pham Van	176	M	168.0	58.0	'39 • 7 • 6	" Scratch Sprint, Team Pursuit,
Loc, Nguyen The	276	M	168.0	68.0	'35 • 9 • 5	Fencing Escrime Ind. Road
Xuan, Tran Van	275	M	174.0	54.0	'34 • 9 • 6	" Sabre, Foil Ind.
Le Ba, Thanh		M	169.0	75.0	'34 • 10 • 12	Judo Foil, Epee, Sabre Ind.
Nguyen Van, Binh		M	163.0	63.5	'39 • 12 • 1	" Middle Weight
Thai Thuc, Thuan		M	169.0	75.0	'27 • 3 • 28	" Light Weight
Dong, Phan Huu		M	167.0	63.0	'38 • 11 • 14	" Middle Weight
Hai, Huynh Van		M	172.0	60.0	'40 • 8 • 20	Swimming and Diving Natation et Plongeurs 100m Free
Le, Nguyen Dinh		M	166.0	51.0	'49 • 5 • 9	" 200m Breast
						" 100m Free
YUGOSLAVIA YOUGOSLAVE						
Cervan, Franc	782	M	179.0	71.0	'36 • 10 • 14	Athletics Athlétisme 5000m, 10000m
Farkas, Gizela	236	F	176.0	58.0	'42 • 10 • 22	" 800m
Kovac, Djani	783	M	181.0	71.0	'39 • 2 • 27	" 400m Hurdles
Lesek, Roman	785	M	178.0	72.0	'37 • 8 • 7	" Pole Vault
Pulic, Olga	238	F	179.0	70.0	'42 • 9 • 27	" High Jump
Radosevic, Dako	786	M	189.0	105.0	'34 • 8 • 17	" Discus Throw
Span, Slavko	784	M	176.0	69.0	'38 • 5 • 25	" 3000m S. C.
Stamejcic, Draga	237	F	167.0	60.0	'37 • 2 • 27	" 80m Hurdles, Pentathlon
Vazic, Simo	781	M	181.0	71.0	'34 • 8 • 22	" 1500m, 5000m
Balas, Zdenko		M	161.0	53.0	'40 • 9 • 9	Rowing Aviron Pair, Four, Eight, With Cox
Barut, Jadran		M	178.0	73.0	'40 • 12 • 30	" Four, Without Cox, Eight, With Cox
Berc, Joza		M	190.0	85.0	'44 • 12 • 5	" Four, Eight, With Cox
Colja, Alojz		M	178.0	80.0	'43 • 5 • 21	" Four, Without Cox, Eight, With Cox
Guberina, Ante		M	189.0	94.0	'40 • 11 • 24	" Pair, With Cox
Janjusevic, Slavko		M	189.0	84.0	'41 • 5 • 7	" Pair, With Cox
Kazija, Frane		M	182.0	81.0	'40 • 7 • 12	" Reserve, Oarsmen
Klavora, Boris		M	174.0	72.0	'41 • 5 • 20	" Four, Without Cox, Eight, With Cox
Kleva, Lucijan		M	189.0	84.0	'42 • 2 • 15	" Four, Eight, With Cox
Mandic, Marko		M	185.0	77.0	'39 • 7 • 20	" Four, Eight, With Cox
Martic, Pavao		M	186.0	82.0	'40 • 11 • 23	" Four, Eight, With Cox
Skalak, Vjekoslav		M	180.0	79.0	'38 • 9 • 28	" Four, Without Cox, Eight, With Cox

NAME NOM	NO. NO.	SEX SEXE	HEIGHT HAUTEUR	WEIGHT POIDS	DATE OF BIRTH DATE DE NAISSANCE	EVENT EPREUVE
Cvetkovic, Vladimir	13	M	196.0	90.0	'41 • 5 • 24	Basket-Ball
Daneu, Ivo	10	M	184.0	84.0	'37 • 10 • 6	"
Djerdja, Josip	8	M	177.0	76.0	'37 • 11 • 24	"
Djuric, Nemanja	14	M	196.0	98.0	'36 • 6 • 18	"
Eiselt, Vital	12	M	187.0	78.0	'41 • 6 • 5	"
Gordic, Slobodan	4	M	191.0	92.0	'37 • 9 • 28	"
Korac, Radivoj	5	M	193.0	95.0	'38 • 11 • 5	"
Kovacic, Dragan	7	M	193.0	91.0	'39 • 10 • 5	"
Nikolic, Miodrag	15	M	188.0	88.0	'38 • 8 • 22	"
Petricevic, Zvonko	11	M	210.0	118.0	'40 • 7 • 26	"
Rajkovic, Trajko	6	M	206.0	94.0	'37 • 12 • 17	"
Raznatovic, Dragoslav	9	M	190.0	85.0	'41 • 4 • 19	"
Desancic, Dragan	164	M	174.0	71.0	'38 • 10 • 1	Canoeing Canotage
Ignjatijevic, Vladimir	165	M	180.0	73.0	'41 • 5 • 6	"
Kercov, Aleksandar	166	M	178.0	75.0	'40 • 11 • 29	"
Radmanovic, Stanisa	167	M	180.0	77.0	'40 • 10 • 8	"
Belin, Rudolf	4	M	177.0	74.0	'42 • 11 • 4	Football
Brncic, Marijan	15	M	182.0	76.0	'40 • 7 • 23	"
Cop, Milan	5	M	175.0	75.0	'38 • 10 • 5	"
Curkovic, Ivan	1	M	179.0	78.0	'43 • 3 • 15	"
Dzajic, Dragan	11	M	177.0	68.0	'46 • 5 • 30	"
Fazlagic, Mirsad	2	M	183.0	75.0	'43 • 4 • 4	"
Jeftic, Zivorad	13	M	168.0	70.0	'44 • 12 • 27	"
Lemic, Lazar	10	M	175.0	73.0	'37 • 9 • 20	"
Miladinovic, Jovan	6	M	180.0	75.0	'39 • 1 • 30	"
Osim, Ivan	9	M	187.0	80.0	'41 • 5 • 6	"
Pavlic, Djordje	16	M	170.0	71.0	'37 • 8 • 28	"
Pirmajer, Josip	17	M	184.0	80.0	'44 • 2 • 14	"
Radovic, Lazar	14	M	172.0	67.0	'35 • 11 • 30	"
Samardzic, Spasoje	7	M	175.0	70.0	'42 • 5 • 20	"
Skoric, Zlatko	12	M	182.0	82.0	'41 • 7 • 27	"
Takac, Silvester	18	M	167.0	66.0	'40 • 11 • 8	"
Vujovic, Svetozar	3	M	178.0	76.0	'40 • 3 • 3	"
Zambata, Slaven	8	M	179.0	77.0	'40 • 9 • 29	"
Brodnik, Janez	23	M	171.0	68.0	'44 • 5 • 6	Gymnastics Gymnastique
Caklec, Ivan	21	M	174.0	78.0	'32 • 8 • 5	"
Cerar, Miroslav	22	M	172.0	71.0	'39 • 10 • 28	"
Petrovic, Alojz	25	M	169.5	63.0	'36 • 5 • 12	"
Srot, Martin	26	M	167.0	64.0	'38 • 8 • 10	"
Vidovic, Nenad	24	M	169.0	65.0	'39 • 5 • 5	"
Cucic, Petar		M	182.0	97.0	'35 • 3 • 18	Wrestling Lutte
Horvat, Stevan		M	170.0	70.0	'32 • 10 • 7	"
Martinovic, Branko		M	169.0	63.0	'37 • 11 • 29	"
Simic, Branislav		M	180.0	87.0	'35 • 3 • 21	"
Djakovic, Slobodan		M	175.0	67.0	'47 • 7 • 6	Swimming and Diving Natation et Plongeurs
Rogusic, Veljko		M	185.0	95.0	'41 • 7 • 20	"
Bonacic, Ozren		M	195.0	104.0	'42 • 1 • 5	Water Polo
Jankovic, Zoran		M	178.0	95.0	'40 • 1 • 8	"
Muskatirovic, Milan		M	197.0	95.0	'34 • 3 • 9	"
Nardeli, Ante		M	189.0	90.0	'37 • 4 • 15	"
Nonkovic, Frane		M	179.0	82.0	'35 • 4 • 25	"
Rosio, Vinko		M	185.0	92.0	'41 • 5 • 22	"
Sandic, Mirko		M	202.0	110.0	'42 • 5 • 9	"
Simenc, Zlatko		M	196.0	87.0	'38 • 11 • 29	"
Stanisic, Bozidar		M	187.0	91.0	'36 • 10 • 21	"
Stipanac, Karlo		M	181.0	82.0	'41 • 12 • 8	"
Trumbic, Ivo		M	196.0	94.0	'35 • 4 • 2	"

Comparison of average height and weight of all participating athletes for each sport of the Rome and Tokyo Olympic Games

Note: Average age were only for the Tokyo Olympic Games.

Events	Rome			Tokyo			Average Age (years & months)
	Height (cm)	Weight (kg)	No. of Athletes	Height (cm)	Weight (kg)	No. of Athletes	
ATHLETICS							
(Men)							
100m	176.2	70.3	63	175.6	71.3	71	24.00
200m	177.0	70.6	70	176.8	70.4	67	24.07
400m	176.9	70.0	56	178.1	70.3	56	24.02
800m	177.5	67.4	56	178.5	68.5	50	24.06
1500m	177.2	66.3	46	176.8	65.6	52	24.09
5000m	172.6	62.7	50	172.0	63.8	55	26.09
10000m	171.2	61.7	43	173.2	62.0	44	27.08
Marathon	170.4	60.8	73	170.5	60.8	75	28.03
110m Hurdles	184.5	77.1	35	182.2	75.3	39	24.11
400m Hurdles	178.5	69.9	35	180.4	73.0	42	24.04
3000m Steeplechase	174.9	65.3	35	172.3	63.2	31	26.05
20km Walk	176.5	67.5	35	175.7	67.1	37	26.09
50km Walk	177.0	69.4	35	175.1	65.9	40	29.11
4X100m Relay	176.8	70.1	120	175.9	70.7	113	24.05
4X400m Relay	178.0	70.3	118	178.5	70.5	111	24.04
High Jump	185.2	77.4	33	185.8	77.7	29	23.01
Long Jump	178.9	71.8	52	176.2	73.7	37	25.02
Triple Jump	179.5	72.1	40	179.1	71.3	34	26.04
Pole Vault	180.5	74.8	31	179.4	72.5	32	20.07
Shot Put	186.0	98.8	31	189.1	104.8	25	26.06
Discus Throw	187.9	96.8	25	188.6	101.5	30	27.08
Javelin Throw	182.9	84.5	28	183.2	83.7	27	25.11
Hammer Throw	183.7	93.6	28	182.7	96.1	25	29.02
Decathlon	183.9	81.4	30	183.6	83.6	23	26.01
(Women)							
100m	166.3	57.8	37	180.0	56.3	49	22.05
200m	166.7	57.5	36	166.6	57.0	45	22.02
400m	—	—	—	166.3	56.9	23	23.03
800m	166.5	56.9	31	167.9	56.9	23	24.02
80m Hurdles	168.6	60.8	27	168.3	60.1	32	24.05
4X100m Relay	167.0	57.7	54	166.0	57.2	88	22.03
High Jump	172.9	63.3	23	172.6	62.2	27	22.09
Long Jump	166.4	58.2	30	167.6	58.3	32	22.10
Shot Put	170.7	75.3	18	174.0	81.8	17	25.03
Discus Throw	173.0	74.6	21	174.1	76.6	22	26.02
Javelin Throw	170.1	66.2	22	170.1	67.8	16	24.09
Pentathlon	—	—	—	171.2	63.4	22	24.00
ROWING							
Single Sculls	185.8	81.3	12	183.9	80.4	17	25.03
Double Sculls	182.6	81.1	30	182.9	79.2	28	24.05
Pair-Oars without Cox	183.9	80.2	35	185.0	80.6	34	25.10
Pair-Oars with Cox	179.1	72.5	47	179.0	74.9	48	25.07
Four-Oars without Cox	183.7	80.8	90	184.6	81.9	66	25.03
Four-Oars with Cox	180.0	75.9	86	181.0	77.3	90	24.02
Eight-Oars with Cox	181.7	77.6	120	183.0	80.0	128	24.09
BASKET-BALL	188.2	83.6	192	190.1	84.6	190	25.00
BOXING							
Fly-weight	160.7		28	162.5	50.9	27	21.09

Events	Rome			Tokyo			Average Age (years & months)
	Height (cm)	Weight (kg)	No. of Athletes	Height (cm)	Weight (kg)	No. of Athletes	
Bantam-weight	163.2		26	163.3	54.2	34	23.05
Feather-weight	166.5		29	167.1	57.0	31	22.02
Light-weight	167.9		26	168.2	59.9	33	23.08
Light Welter-weight	171.7		27	172.6	63.4	34	23.03
Welter-weight	173.0		30	174.7	67.1	28	24.04
Light Middle-weight	174.1		17	174.8	69.8	26	24.08
Middle-weight	176.8		21	176.7	75.1	18	25.02
Light Heavy-weight	181.6		14	180.9	80.7	18	26.02
Heavy-weight	184.1	92.2	15	186.9	87.9	14	25.01
CANOEING							
(Men)							
Kayak Singles	177.3	74.6	35	179.3	77.2	19	26.04
Kayak Pairs	177.7	74.4	64	177.6	74.9	33	25.07
Canadian Singles	178.9	76.2	17	180.0	76.1	11	24.06
Canadian Pairs	174.5	72.5	26	178.0	76.2	24	25.02
Kayak Fours	—	—	—	178.7	77.0	60	25.04
(Women)							
Kayak Singles	165.5	61.2	19	164.8	63.0	13	24.03
Kayak Pairs	165.8	62.4	24	166.2	62.3	22	24.00
CYCLING							
1000m Time Trial	176.8	71.8	24	175.7	71.4	27	22.10
Scratch Sprint Race	174.8	72.3	34	173.8	71.2	42	22.09
Tandem Sprint Race	173.1	69.3	25	175.1	73.6	26	25.07
4000m Individual Pursuit Race	—	—	—	176.0	69.3	28	24.02
4000m Team Pursuit Race	176.1	71.4	57	174.9	69.0	80	23.07
Individual Road Race	174.3	69.2	115	173.5	68.4	137	24.02
Team Road Race Time Trial	174.8	69.9	106	173.2	68.1	124	24.01
FENCING							
(Men)							
Epée, Individual	178.4	72.7	77	178.9	73.2	66	29.05
Epée, Team	179.1	73.0	101	178.9	72.4	88	29.07
Sabre, Individual	177.1	73.6	75	175.1	70.9	53	30.08
Sabre, Team	176.8	72.6	82	176.3	71.4	63	29.08
Foil, Individual	176.1	71.2	80	176.1	69.9	54	27.02
Foil, Team	175.9	70.5	86	175.6	70.3	72	27.09
(Women)							
Foil, Individual	164.4	58.2	53	163.8	58.6	38	26.04
Foil, Team	164.8	59.1	52	165.7	60.1	48	26.09
FOOTBALL	173.5	69.6	250	173.5	69.9	244	24.08
GYMNASTICS							
(Men)	168.9	65.2	95	167.7	63.6	142	25.06
(Women)	159.2	53.4	103	158.1	52.7	95	22.02
WEIGHT-LIFTING							
Bantam-weight	158.6		25	157.2	56.3	28	26.05
Feather-weight	160.1		20	161.0	60.4	22	27.11
Light-weight	165.8		31	164.8	67.3	20	26.11
Middle-weight	169.2		25	168.1	74.9	21	25.05
Light Heavy-weight	173.7		17	170.7	81.9	25	27.05
Middle Heavy-weight	173.7		22	174.5	89.2	19	26.02
Heavy-weight	180.3	119.6	17	180.6	117.1	20	29.00
HOCKEY	173.9	69.2	197	180.6	70.4	239	26.07
JUDO							
Light-weight	—	—	—	169.0	66.2	24	24.08

Events	Rome			Tokyo			Average Age (years & months)
	Height (cm)	Weight (kg)	No. of Athletes	Height (cm)	Weight (kg)	No. of Athletes	
Middle-weight	—	—	—	174.8	77.3	24	25.03
Heavy-weight	—	—	—	181.2	94.2	12	28.04
All-weight	—	—	—	181.9	97.7	8	27.10
WRESTLING							
(Free style)							
Fly-weight	161.1	—	15	158.6	53.3	21	25.04
Bantam-weight	164.2	—	17	165.8	58.0	20	25.04
Feather-weight	167.0	—	24	167.8	64.0	21	27.02
Light-weight	168.9	—	23	171.2	70.3	23	25.02
Welter-weight	172.0	—	22	174.0	78.2	23	27.09
Middle-weight	175.7	—	19	180.4	87.1	18	26.02
Light Heavy-weight	178.8	—	18	180.1	96.0	17	28.03
Heavy-weight	183.8	106.5	17	182.9	105.2	13	28.02
(Greco-Roman style)							
Fly-Weight	160.9	—	16	157.7	53.2	18	27.00
Bantam-weight	164.7	—	22	163.5	58.9	16	25.06
Feather-weight	166.9	—	22	166.3	63.9	23	28.10
Light-weight	169.6	—	18	170.4	70.6	19	26.10
Welter-weight	172.9	—	21	174.7	78.3	19	28.04
Middle-weight	174.8	—	20	179.6	86.8	19	26.10
Light Heavy-weight	179.1	—	11	182.5	96.4	18	27.02
Heavy-weight	185.5	105.7	11	186.0	112.0	12	27.08
SWIMMING & DIVING							
(Men)							
100m Free style	180.0	74.7	44	180.0	74.8	60	20.08
400m Free style	177.5	74.1	37	178.2	74.6	52	19.10
1500m Free style	175.9	71.9	32	186.4	72.9	35	19.05
100m Back stroke	179.4	74.5	38	—	—	—	—
200m Breast stroke	—	—	—	175.9	72.8	31	22.07
200m Back stroke	178.9	71.1	33	181.8	75.6	33	21.06
200m Butterfly stroke	175.0	72.4	33	175.2	72.7	32	19.06
400m Individual Medley	—	—	—	177.8	72.9	28	19.10
4X100m Free style relay	—	—	—	179.6	74.0	48	20.10
4X200m Free style relay	179.1	74.6	73	180.1	74.9	64	20.08
4X100m Medley relay	179.8	75.5	63	180.2	77.3	50	21.00
Springboard Diving	170.4	66.4	29	170.5	66.0	29	22.11
High Diving	170.1	65.6	25	169.9	66.7	31	23.10
(Women)							
100m Free style	167.9	61.3	26	168.1	60.4	41	18.01
400m Free style	165.4	57.8	20	165.5	58.3	34	17.09
200m Breast stroke	168.8	63.0	26	168.1	62.5	25	18.08
100m Back stroke	170.0	61.9	25	167.7	60.2	28	18.07
100m Butterfly stroke	163.5	60.1	23	167.0	60.0	32	18.03
400m Individual Medley	—	—	—	165.2	59.3	22	18.08
4X100m Free style relay	167.6	61.8	61	166.7	59.5	48	17.08
4X100m Medley relay	168.4	63.0	41	167.2	61.1	42	18.06
Springboard Diving	161.2	54.9	16	160.6	54.5	19	20.01
High Diving	159.7	53.5	15	161.1	54.8	22	19.11
MODERN PENTATHLON	176.7	71.1	65	178.6	72.2	46	26.06
EQUESTRIAN SPORTS							
(Men)							
Grand Prix Dressage	174.9	72.0	12	175.0	70.0	15	40.03
Three-day Event	175.0	69.0	64	174.1	66.8	47	30.10

Events	Rome			Tokyo			Average Age (years & months)
	Height (cm)	Weight (kg)	No. of Athletes	Height (cm)	Weight (kg)	No. of Athletes	
Olympic Grand Prix Jumping (Women)	172.7	67.6	68	173.7	68.3	48	32.01
Grand Prix Dressage	166.0	54.0	5	168.1	55.0	9	26.09
Three-day Event	—	—	—	168.8	55.5	2	25.04
Olympic Grand Prix Jumping	167.7	59.3	3	164.8	56.0	4	23.03
SHOOTING							
Free Rifle	—	—	—	172.7	72.5	37	32.10
Small Bore Rifle, 3 position	—	—	—	172.0	73.8	57	32.11
Small Bore Rifle, prone	—	—	—	172.8	72.8	72	34.02
Free Pistol	—	—	—	172.7	75.0	52	35.03
Rapid Fire Pistol	—	—	—	174.4	75.0	53	33.05
Clay Pigeon	—	—	—	176.5	81.6	47	37.05
VOLLEY-BALL							
(Men)	—	—	—	184.7	79.0	118	26.01
(Women)	—	—	—	171.2	65.4	71	24.05
WATER-POLO							
	182.2	82.1	125	182.1	81.5	111	25.10
YACHTING							
5.5m class	177.8	77.5	50	178.8	79.2	45	35.08
Dragon class	174.6	72.4	78	174.9	75.1	57	36.02
Star class	175.8	77.9	52	178.6	72.2	28	35.02
Flying Dutchman class	177.4	76.0	53	177.6	75.8	40	30.03
Finn class	177.4	78.9	29	179.0	79.6	30	29.02

Comparison of average height and weight of winners for each sport of the Rome and Tokyo Olympic Games

Note: * mark indicates team competition

Events	Rome			Tokyo			Age (years & months)
	Height (cm)	Weight (kg)	No. of Athletes	Height (cm)	Weight (kg)	No. of Athletes	
ATHLETICS							
(Men)							
100m	182.0	72.0	1	183.0	86.0	1	21.09
200m	180.0	66.0	1	191.0	84.0	1	21.10
400m	185.0	74.0	1	186.0	77.0	1	25.10
800m	179.0	—	1	179.0	—	1	25.09
1500m	183.0	68.0	1	179.0	—	1	25.09
5000m	177.0	—	1	184.0	66.0	1	27.00
10000m	173.0	64.0	1	180.0	70.0	1	26.07
Marathon	176.0	55.0	1	177.0	61.0	1	32.02
110m Hurdles	185.0	75.0	1	178.0	73.0	1	26.02
400m Hurdles	185.0	74.0	1	183.0	75.0	1	24.03
3000m Steeplechase	172.0	60.0	1	174.0	58.0	1	27.08
20km Walk	177.0	75.0	1	185.0	73.5	1	30.03
50km Walk	166.0	57.0	1	183.0	74.0	1	31.00
4X100m Relay	182.0	76.0	*4	182.0	75.5	*4	22.02
4X400m Relay	186.0	78.0	*4	188.0	77.3	*4	24.04
High Jump	186.0	82.0	1	184.0	75.0	1	22.05
Long Jump	186.0	74.0	1	189.0	82.5	1	22.04
Triple Jump	183.0	76.0	1	183.0	76.0	1	29.06
Pole Vault	190.0	91.0	1	183.0	75.0	1	23.09
Shot Put	190.0	106.0	1	193.0	118.0	1	24.03
Discus Throw	192.0	106.0	1	193.0	118.0	1	28.00
Javelin Throw	188.0	101.0	1	178.0	80.0	1	23.11
Hammer Throw	187.0	98.0	1	187.0	103.0	1	31.04
Decathlon	190.0	91.0	1	182.0	90.0	1	24.07
(Women)							
100m	180.0	61.0	1	170.0	61.0	1	19.01
200m	180.0	61.0	1	173.0	59.0	1	19.04
400m	—	—	—	169.0	57.0	1	26.05
800m	163.0	69.0	1	169.0	56.5	1	22.07
80m Hurdles	168.0	62.0	1	171.0	60.0	1	26.04
4X100m Relay	167.0	56.0	*4	170.0	59.3	*4	22.02
High Jump	186.0	71.0	1	184.0	72.0	1	27.09
Long Jump	157.0	57.0	1	172.0	59.5	1	24.08
Shot Put	180.0	94.0	1	180.0	100.0	1	27.05
Discus Throw	173.0	84.0	1	180.0	100.0	1	27.05
Javelin Throw	174.0	66.0	1	186.0	94.0	1	17.02
Pentathlon	—	—	—	168.0	74.0	1	25.00
ROWING							
Single Sculls	188.0	85.0	1	190.0	85.0	1	26.02
Double Sculls	179.0	80.0	*2	182.0	75.3	*2	26.01
Pair-Oars without Cox	180.0	74.0	*2	197.0	84.8	*2	21.08
Pair-Oars with Cox	181.0	74.0	*3	188.0	78.0	*3	27.08
Four-Oars without Cox	194.0	87.0	*4	186.0	86.1	*4	23.09
Four-Oars with Cox	188.0	78.0	*5	188.0	83.8	*5	23.07
Eight-Oars with Cox	184.0	82.0	*9	187.0	85.0	*9	28.06
BASKET-BALL	196.0	89.0	*12	197.0	93.0	*12	24.00
BOXING							
Fly-weight	161.0	54.0	1	158.0	51.0	1	22.04

Events	Rome			Tokyo			Age (years & months)
	Height (cm)	Weight (kg)	No. of Athletes	Height (cm)	Weight (kg)	No. of Athletes	
Bantam-weight	156.0	54.0	1	164.0	54.0	1	23.00
Feather-weight	168.0	57.0	1	163.0	57.0	1	24.01
Light-weight	—	—	—	168.0	60.0	1	25.06
Light Welter-weight	175.0	63.0	1	167.0	63.0	1	23.11
Welter-weight	178.0	67.0	1	168.0	67.0	1	25.00
Light Middle-weight	170.0	70.0	1	180.0	71.0	1	26.03
Middle-weight	172.0	74.0	1	176.0	75.0	1	27.01
Light Heavy-weight	187.0	80.0	1	178.0	81.0	1	21.06
Heavy-weight	186.0	96.0	1	180.0	89.0	1	20.08
CANOEING							
(Men)							
Kayak Singles	182.0	77.0	1	185.0	75.0	1	20.04
Kayak Pairs	178.0	69.0	*2	181.0	67.5	*2	26.06
Canadian Singles	182.0	83.0	1	176.0	73.0	1	23.01
Canadian Pairs	172.0	65.0	*2	175.0	79.0	*2	28.09
Kayak Fours	—	—	—	182.0	84.3	*4	25.01
(Women)							
Kayak Singles	164.0	66.0	1	164.0	69.0	1	28.08
Kayak Pairs	165.0	65.0	*2	170.0	66.0	*2	24.00
CYCLING							
1000m Time Trial	168.0	66.0	1	178.0	73.0	1	21.06
Scratch Sprint Race	168.0	66.0	1	180.0	76.0	1	20.03
Tandem Sprint Race	173.0	70.0	*2	174.0	74.5	*2	25.09
4000m Individual Pursuit Race	—	—	—	184.0	82.0	1	24.07
4000m Team Pursuit Race	170.0	66.0	*4	180.0	74.3	*4	22.04
Individual Road Race	178.0	73.0	1	174.0	74.0	1	24.03
Team Road Race Time Trial	176.0	70.0	*4	177.0	73.0	*4	21.03
FENCING							
(Men)							
Epée, Individual	—	—	—	175.0	69.0	1	23.09
Epée, Team	—	—	—	184.0	76.5	*4	27.08
Sabre, Individual	179.0	64.0	1	190.0	82.0	1	28.10
Sabre, Team	181.0	76.0	*6	176.0	75.0	*4	29.00
Foil, Individual	182.0	78.0	1	176.0	68.0	1	28.11
Foil, Team	176.0	74.5	*5	178.0	74.3	*4	28.07
(Women)							
Foil, Individual	166.0	63.0	1	164.0	58.0	1	27.04
Foil, Team	162.0	56.0	*6	165.0	59.5	*4	28.10
FOOTBALL	177.0	76.0	*16	176.0	71.5	*11	23.11
GYMNASTICS							
(Men)							
Individual	171.0	71.0	1	161.0	58.0	1	27.08
Team Competition	159.0	55.0	*5	161.0	57.8	*6	27.01
Competition by apparatus:							
Horizontal Bar	160.0	58.0	1	172.0	70.0	1	32.08
Parallel Bars	171.0	71.0	1	161.0	58.0	1	27.08
Rings	174.0	72.0	1	160.0	58.0	1	24.00
Floor Exercise	154.0	53.0	1	162.0	60.0	1	23.02
Side Horse	174.0	70.0	*2	172.0	71.0	1	24.11
Long Horse Vault	165.0	64.0	*2	165.0	60.0	1	25.10
(Women)							
Individual	161.0	52.0	1	160.0	55.0	1	22.05
Team Competition	162.0	55.0	*5	160.0	52.4	*6	25.09

Events	Rome			Tokyo			Age (years & months)
	Height (cm)	Weight (kg)	No. of Athletes	Height (cm)	Weight (kg)	No. of Athletes	
Competition by apparatus:							
Uneven Parallel Bars	166.0	56.0	1	167.0	56.0	1	27.11
Floor Exercise	161.0	52.0	1	163.0	52.0	1	29.09
Horse Vault	159.0	55.0	1	160.0	55.0	1	22.05
Balance Beam	162.0	59.0	1	160.0	55.0	1	22.05
WEIGHT-LIFTING							
Bantam-weight	152.0	56.0	1	156.0	58.0	1	29.06
Feather-weight	156.0	60.0	1	154.0	60.0	1	24.09
Light-weight	162.0	67.0	1	165.0	67.0	1	29.01
Middle-weight	165.0	75.0	1	169.0	75.0	1	23.00
Light Heavy-weight	172.0	81.0	1	172.0	83.0	1	36.01
Middle Heavy-weight	169.0	90.0	1	172.0	90.0	1	25.10
Heavy-weight	185.0	123.0	1	190.0	157.0	1	26.08
HOCKEY	175.0	69.0	18	169.0	67.7	*11	28.03
JUDO							
Light-weight	—	—	—	165.0	69.0	1	23.03
Middle-weight	—	—	—	171.0	80.0	1	20.08
Heavy-weight	—	—	—	173.0	88.0	1	26.08
All-weight	—	—	—	196.0	120.0	1	30.06
WRESTLING							
(Free style)							
Fly-weight	160.0	—	1	161.0	56.0	1	22.11
Bantam-weight	162.0	57.0	1	165.0	61.0	1	21.08
Feather-weight	168.0	—	1	160.0	65.0	1	23.11
Light-weight	170.0	67.0	1	170.0	—	1	28.09
Welter-weight	170.0	73.0	1	170.0	73.0	1	31.07
Middle-weight	173.0	—	1	175.0	—	1	28.06
Light Heavy-weight	173.0	—	1	187.0	97.0	1	27.00
Heavy-weight	182.0	110.0	1	189.0	106.0	1	26.10
(Greco-Roman style)							
Fly-weight	166.0	52.0	1	160.0	57.0	1	24.09
Bantam-weight	161.0	57.0	1	162.0	62.0	1	24.02
Feather-weight	169.0	—	1	170.0	63.0	1	32.05
Light-weight	167.0	67.0	1	170.0	70.0	1	26.07
Welter-weight	172.0	—	1	174.0	80.0	1	26.08
Middle-weight	175.0	79.0	1	180.0	87.0	1	29.06
Light Heavy-weight	188.0	—	1	173.0	—	1	21.10
Heavy-weight	185.0	108.0	1	198.0	135.0	1	24.10
SWIMMING & DIVING							
(Men)							
100m Free style	184.0	85.0	1	182.0	75.0	1	18.05
400m Free style	184.0	80.0	1	182.0	75.0	1	18.05
1500m Free style	180.0	83.0	1	—	—	1	—
100m Back stroke	189.0	—	1	—	—	—	—
200m Breast stroke	189.0	83.0	1	—	—	1	—
200m Back stroke	—	—	—	198.0	91.0	1	22.05
200m Butterfly stroke	185.0	77.0	1	—	—	1	—
400m Individual Medley	—	—	—	184.0	84.0	1	17.00
4X100m Free style relay	—	—	—	185.0	81.5	*4	20.05
4X200 Free style relay	186.0	79.0	*4	185.0	80.8	*4	20.01
4X100m Medley relay	186.0	78.0	*4	184.0	77.8	*4	20.11
Springboard Diving	183.0	73.0	1	177.0	70.0	1	19.07
High Diving	175.0	63.0	1	175.0	68.0	1	25.11

Events	Rome			Tokyo			Age (years & months)
	Height (cm)	Weight (kg)	No. of Athletes	Height (cm)	Weight (kg)	No. of Athletes	
(Women)							
100m Free style	172.0	67.0	1	—	—	1	—
400m Free style	178.0	63.0	1	170.0	61.0	1	17.07
200m Breast stroke	178.0	70.0	1	169.0	71.0	1	15.10
100m Back stroke	173.0	61.0	1	173.0	61.0	1	16.02
100m Butterfly stroke	167.0	63.0	1	173.0	61.0	1	15.11
400m Individual Medley	—	—	—	168.0	61.0	1	17.05
4X100m Free style relay	172.0	60.0	*4	171.0	60.8	*4	16.04
4X100m Medley relay	169.0	61.0	*4	171.0	58.3	*4	17.00
Springboard Diving	158.0	56.0	1	157.0	54.0	1	21.02
High Diving	158.0	56.0	1	160.0	52.0	1	17.00
MODERN PENTATHLON							
Individual	181.0	71.0	1	176.0	67.0	1	29.02
Team	175.0	70.0	*4	184.0	80.0	*3	27.00
EQUESTRIAN EVENTS							
Grand Prix Dressage, Individual	172.0	81.0	1	175.0	68.0	1	46.02
Grand Prix Dressage, Team	—	—	—	184.0	68.3	*3	38.06
Three-day Event, Individual	180.0	73.0	1	—	—	1	21.07
Three-day Event, Team	180.0	73.0	*3	—	—	*3	23.03
Olympic Grand Prix Jumping, Individual	—	—	—	173.0	70.0	1	44.80
Olympic Grand Prix Jumping, Team	170.0	69.0	*3	176.0	67.7	*3	30.05
SHOOTING							
Free Rifle	172.0	78.0	1	183.0	68.0	1	25.00
Small Bore Rifle, 3 positions	172.0	78.0	1	170.0	82.0	1	27.01
Small Bore Rifle, prone	178.0	72.0	1	180.0	84.0	1	22.07
Free Pistol	170.0	84.0	1	170.0	67.0	1	35.05
Rapid Fire Pistol	183.0	91.0	1	182.0	79.0	1	31.06
Clay Pigeon	179.0	98.0	1	180.0	80.0	1	36.02
VOLLEY-BALL							
(Men)	—	—	—	184.0	84.0	*12	27.02
(Women)	—	—	—	169.0	62.2	*12	23.03
WATER-POLO	182.0	81.0	*12	180.0	81.2	*11	27.10
YACHTING							
5.5m class	179.0	81.0	*3	183.0	81.9	*3	37.08
Dragon class	174.0	70.0	*3	177.0	74.2	*3	39.08
Star class	167.0	69.0	*2	184.0	74.5	*2	44.01
Flying Dutchman class	179.0	70.0	*2	183.0	83.5	*2	32.08
Finn class	182.0	85.0	1	184.0	85.0	1	21.09

No figures in the column of height and weight for the athletes of the Tokyo Games indicate omissions on entry forms.

The Official Report of the Games of the XVIII Olympiad, Tokyo 1964

Volume I

Edited & published by: The Organizing Committee for the Games of the XVIII Olympiad

Bound by: HARA Hiromu

Photographs were kindly offered by: Asahi Shinbun (The Press Asahi) (in alphabetical order)
Ginso Photo Design Co., Ltd.
Hitachi, Ltd.
Japan Airport Terminal Co., Ltd.
Japan Broadcasting Corporation (Nippon Hoso Kyokai)
Kishimoto Photo Company
Kokusai Denshin Denwa Co., Ltd.
Konishiroku Photo Industry Co., Ltd.
Kyodo News Service
Mainichi Shinbun (The Mainichi Newspapers Publishing Co., Ltd.)
Nippon Express Co., Ltd.
Nippon Telegraph and Telephone Public Corporation
Pan-Asia Newspaper Alliance
Public Relations Section, Tokyo Metropolitan Police Department
Radio Research Laboratories, Ministry of Posts and Telecommunications
Tokyo National Museum
Tokyo Tourist Association
301st Photo-Company, Japan Ground Self-Defence Force

Date issued: October, 1966

Printed in Japan by Kyodo Printing Co., Ltd., Tokyo

Notes on the digitized version of the Official Report of The Games of the XVIII Olympiad Tokyo 1964, Volume 1

The digital version of the Official Report of the The Games of the XVIII Olympiad Tokyo 1964, Volume 1 was created with the intention of producing the closest possible replica of the original printed document. These technical notes describe the differences between the digital and printed documents and the technical details of the digital document.

The original document:

The original paper version of the Official Report of The Games of the XVIII Olympiad Tokyo 1964, Volume 1 has dimensions of 8.25" x 11.65" (21 cm x 29.5 cm).

The volume's spine is of grey cloth.

The book has 664 pages.

The fonts used in the digital version book for text, photograph captions and chapter headings are NewBaskerville and such system fonts as best approximate the original fonts.

Special features of the digital version:

- The spine is not included in the digital version.
- Blank pages are not included in the digital version.
- The digital version includes a bookmark list that functions as a hyper linked table of contents. Selecting a topic heading will take you to the corresponding section in the document.

The text of the Tokyo 1964 official report, Volume 1 contains a number of errors:

Page	Error	Correction
	technicological	technological
TOC	Maintenance of village facilities and service	Maintenance of village facilities and security service
TOC	Oversea's	Overseas
34	The decision withdraw	The decision to withdraw
35	secretariate	secretariats
39	defering	deferring
40	Organization	Organizations
47	Venezuera	Venezuela
49	squards	squads
53	secretariate	secretariat
69	gymansium	gymnasium
79	Cameroun	Cameroon
80	nonmembers	non-members
104	slenegal	senegal
118	forseen	foreseen
118	remodled	remodeled
120	obstracting	obstructing
122	planel	panels
124	stracture	structure
124	cresnet	crescent
127	Splinkler	Sprinkler
128	conjestion	congestion
130	compartively	comparatively
130	widered	widened
131	sord	sort
131	asbesto	asbestos

Page	Error	Correction	Page	Error	Correction
136	horsement	horsemen	287	permissable	permissible
136	coveres	covers	290	preceeded	preceded
137	Riflle	Rifle	301	service	services
137	countermeasure	counter-measure	315	chili	chilli
138	buiding	building	317	Nut meg	Nutmeg
140	evisaged	envisaged	317	Bayleave	Bayleaf
142	ajacent	adjacent	317	Ponpkin	Pumpkin
165	chedules	schedules	317	Saffran	Saffron
166	augumented	augmented	318	bonelese	boneless
168	celulloid	celluloid	318	Aluminium	Aluminum
169	computors	computers	319	glaves	gloves
171	withdrawns	withdrawal	348	Venezueela	Venezuela
172	equestring	equestrian	388	colected	collected
173	infomation	information	431	amonut	amount
173	commerced	commenced	433	equestrain	equestrian
174	semiannual	semi-annual	438	Oversea's	Overseas
174	Torinidad	Trinidad	438	Eest	East
180	refree	referee	439	Sports-Turist	Sports-Tourist
181	Passting	Passing	441	transfered	transferred
182	poraloid	polaroid	441	auxilliary	auxiliary
182	set	sets	442	computer	computer
182	pair	pairs	447	icecream	ice-cream
184	magnifing	magnifying	450	sepayate	separate
184	C hest	Chest	451	microbus's	microbuses
185	baloons	balloons	453	alloted	allotted
191	Personnal	Personnel	453	landen	landed
192	indicaing	indicating	454	courage	coverage
193	traperecorder	taperecorder	463	crowed	crowd
193	Leauge	League	463	unforseeable	unforeseeable
193	equatrian	equestrian	464	trianglar	triangular
193	in dicator	indicator	480	filming	film
193	startin	starting	486	Janitorral	Janitorial
194	wheather	weather	490	diarrhea	diarrhoea
194	boader	border	499	exercises	exercise
219	Programms	Programmes	530	followings	following
221	troup	troupe	540	Midle	Medley
223	rythmically	rhythmically	540	Grand Rrix	Grand Prix
226	dias	dais	585	Grand Frix	Grand Prix
246	carring	carrying	598	Eree	Free

Profile of the digital version:

File name: or1964v1.pdf

File size: 46,993 KB

Format: Portable Document Format (PDF) 1.4 (Adobe Acrobat 5.0)

Source document: The Official Report of The Games of the XVIII Olympiad Tokyo 1964, Volume 1

Printed by: Kyodo Printing Co., Ltd., Tokyo

Creation Platform: Windows XP

Creation Date: August 2005

Conversion Software: Adobe Acrobat, FineReader, VistaScan, FahrenEX

Image Resolution: 96 dpi for color and grayscale images

Digital Fonts: NewBaskerville

Digitization by: Exgenis Technologies, Goa, INDIA

www.digitization.info