

Static Grounding Reels

WARNING

These reels are for static grounding ONLY.
NOT intended for lightning protection!

- Aircraft Refueling • Chemical Plants • Grain Elevators
- Rescue and HazMat Operations

For refueling or hazardous areas.

- These reels bond and/or ground aircraft, fuel trucks, and other equipment.
- Provide smooth operation and require minimum cable pull.
- Declutching arbor and adjustable guide arm with cable guide.
- Optional stainless steel construction of spool, frame, and ratchet system available on HGR Series.
- Standard finish is oven-cured enamel.
- Also available, manual rewind version. All shown with optional cable and/or "Y" branch.



Model HGR50
(Shown with optional "Y" branch)



Model SSHGR50
(Optional unpolished stainless steel HGR50)



Model MHGR50



Model HGR100



Model MHGR100

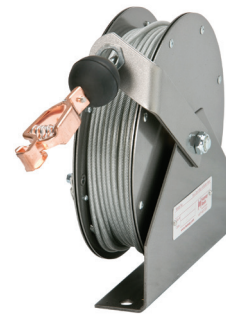

Model GR75



Model MGR75

You Can't Buy A Better Reel.

- Available with 1/8", 7 x 19 galvanized carbon steel cable.
- 100 amp alligator clamp.
- Stainless steel or plastic-covered cable and "Y" branches are available at an additional charge.
- Cable guide arm of cast aluminum and ZA-12 aluminum zinc alloy.

Series GR75

- Sealed spring is a good economical choice that's compact and lightweight.

Series HGR

- A non-sparking ratchet assembly.
- Reels are repairable and parts are readily available.
- Supplied with 18" long grounding strap with eyelet connectors on both ends.

Parts Drawings: HGR Series – ISO 10 and MHGR Series – ISO 234

Model Number	Cable Capacity of Reel feet m	Approx. Weight lb. kg		Reel Dimensions*** in. mm									
		Without Cable	With Cable	A	B	C	D	E	F	G	H	X	Y
GR75	75	11	14*	2	2	7	9	9.25	3.5	9.88	5.06	1	7.88
	23	5	6	51	51	178	229	235	89	251	129	25	200
† MGR75	75†	11	13*	2	2	7	9	9.25	5.25	9.88	5.06	1	7.88
	23†	5	6	51	51	178	229	235	133	251	129	25	200
HGR50	75	28	30*	4	1.25	10.75	11.5	14.25	5.5	16.75	8.88	2.38	7.5
	23	13	14	102	32	273	292	362	159	425	226	60	191
† MHGR50	125†	19	23*	4	1.25	10.75	11.5	14.25	6.25	16.75	8.88	2.38	7.5
	38†	9	10	102	32	273	292	362	159	425	226	60	191
HGR100	100	37	41*	4	1.25	13.25	11.5	16.75	5.5	17.75	8.88	2.38	7.5
	30	17	19	102	32	337	292	425	140	451	226	60	191
† MHGR100	175†	25	31*	4	1.25	13.25	11.5	16.75	6.25	17.75	8.88	2.38	7.5
	53†	11	14	102	32	337	292	425	159	451	226	60	191



Optional Grounding Jack
per MIL-C-8341D/4
Part No. 9951.0033

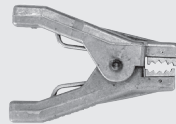

Optional Browne Clamp
(ALS-10)
Part No. 9951.0031

Notes:

1. Specifications subject to change.
 2. When ordering, specify model number, gauge, O.D., length, and coating if required.
 3. Specify "Y" branch if required.
 4. Specify finish if other than standard.
- *Reels can be shipped as a parcel package (via FedEx or UPS Ground).
*** X, Y indicate mounting holes.
† Capacities shown are for PCC (plastic coated cable). Capacities may be higher for uncoated cable; consult factory.

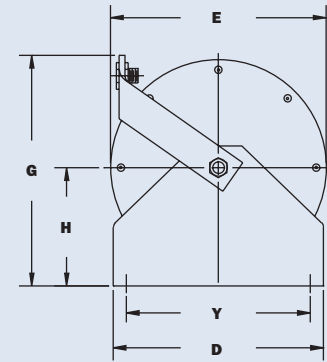
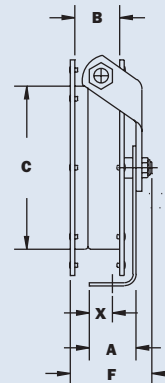

Model GR75/MGR75
GR75 shown

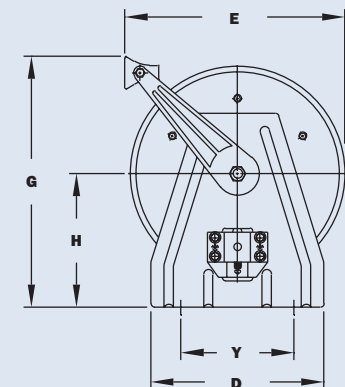
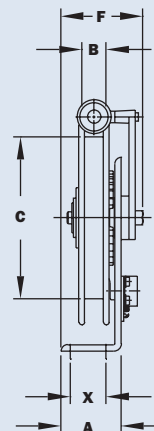

Model HGR50/HGR100/MHGR50
HGR shown



All Hannay reels are constructed of quality heavy gauge steel (optional aluminum or stainless steel also available on most models).



553 State Route 143 | Westerlo, New York 12193
Email: reels@hannay.com | hannay.com