

Measuring the Impact of Fire Extinguisher Agents On Cultural Resource Materials

Final Report

Prepared by:

Hughes Associates, Inc.

© February 2010 Fire Protection Research Foundation



THE
FIRE PROTECTION
RESEARCH FOUNDATION

FIRE RESEARCH

THE FIRE PROTECTION RESEARCH FOUNDATION
ONE BATTERYMARCH PARK
QUINCY, MASSACHUSETTS, U.S.A. 02169
E-MAIL: Foundation@NFPA.org
WEB: www.nfpa.org/Foundation

FOREWORD

Portable fire extinguishers and their associated fire extinguishing agents play an important role in reducing the impact of fire on cultural resource collections. A fire which can be extinguished with a portable extinguisher in its incipient stage will not grow to threaten adjacent materials. While conservators are well versed in the effects of moisture and water on collections, little data is available on the effects of other non-water based extinguishing agents. To fully evaluate the appropriateness of an extinguisher, its extinguishing effectiveness should be compared to the potential collateral damage to collection materials from the agent and its thermal decomposition products. Such contact with collection materials can occur by overspray during firefighting efforts or the direct spraying of collection materials in an act of vandalism.

This project is intended to quantify the impact of discharging portable fire extinguisher agents on cultural resource materials. The results can then be used by the NFPA Technical Committee on Cultural Resources (NFPA 909 and 914) to provide users with guidance on extinguisher selection. Phase I of the project included a comprehensive literature review and the development of prototype specifications and procedures to test the effects of extinguishers. In an anticipated Phase II, the test specifications would be validated and a final test specification produced. The results of Phase I are presented in this report.

The Research Foundation expresses gratitude to the Project Technical Panelists and Sponsors listed on the following page.

The content, opinions and conclusions contained in this report are solely those of the authors.

***Measuring the Impact of Fire Extinguisher Agents
On Cultural Resource Materials
Research Project***

Technical Panel

Bogdan Dlugogorski, University of Newcastle
Deborah Freeland, Arthur J. Gallagher & Company
Cindy Greczek, Colonial Williamsburg Foundation
Michael Kilby, Smithsonian Institution
Nancy Lev-Alexander, U.S. Library of Congress

Sponsors

Amerex Corporation
American Pacific Corporation
National Fire Protection Association
Orr Protection Systems, Inc.
United Technologies Research Center
U.S. General Services Administration

**Literature Review, Test Specifications and Procedures
for Measuring the Impact
of Portable Fire Extinguisher Agents on
Cultural Resource Materials**

Final Report

Prepared by

**Hughes Associates, Inc.
3610 Commerce Drive, Suite 817
Baltimore, MD 21227**

February 2010

TABLE OF CONTENTS

| | Page |
|---|-------------|
| EXECUTIVE SUMMARY | E-1 |
| 1.0 INTRODUCTION | 1 |
| 2.0 PORTABLE FIRE EXTINGUISHER USE FOR PROTECTING CULTURAL COLLECTIONS | 2 |
| 3.0 EARLY STAGE FIRE SCENARIOS | 4 |
| 3.1 Fire Loss Review | 5 |
| 3.2 Fire Hazard Analysis Techniques | 8 |
| 3.3 UL Rating Fire Threats | 9 |
| 4.0 AGENT AND COLLECTION MATERIAL CHARACTERISTICS | 11 |
| 4.1 Agent Characteristics | 11 |
| 4.1.1 ABC Dry Chemicals | 11 |
| 4.1.2 Clean Agents..... | 11 |
| 4.1.3 Carbon Dioxide (CO ₂) | 11 |
| 4.2 Collection and Structural Materials | 12 |
| 5.0 ENVIRONMENTAL IMPACT ON MATERIALS | 12 |
| 5.1 Environmental Effects | 14 |
| 5.1.1 Humidity | 14 |
| 5.1.2 Temperature | 14 |
| 5.1.3 Ambient Light..... | 15 |
| 5.1.4 Indoor Pollutants (Chemicals) | 15 |
| 5.2 Neat Agent Effects | 15 |
| 5.2.1 ABC Dry Chemical..... | 15 |
| 5.2.2 Clean Agents..... | 16 |
| 5.2.3 Carbon Dioxide (CO ₂) | 17 |
| 5.2.4 Water Mist | 18 |
| 5.3 Mechanical Damage..... | 18 |
| 6.0 FIRE EFFECTS ON MATERIALS..... | 18 |
| 6.1 General Impact of Fire on Materials..... | 18 |

| | | |
|-------|---|----|
| 6.2 | Fire Byproducts..... | 19 |
| 6.3 | Fire Impact on Collections..... | 20 |
| 6.3.1 | Norwegian Extinguisher Tests..... | 20 |
| 6.3.2 | Huntington Gallery Fire..... | 21 |
| 7.0 | COMBINED FIRE AND EXTINGUISHING EFFECTS..... | 22 |
| 7.1 | ABC Dry Chemical..... | 22 |
| 7.2 | Clean Agents..... | 23 |
| 7.3 | Carbon Dioxide (CO ₂)..... | 27 |
| 7.4 | Water Mist..... | 27 |
| 7.5 | Summary..... | 27 |
| 8.0 | ESTIMATING DISPERSION AND CONCENTRATION OF CONTAMINANTS..... | 28 |
| 8.1 | Factors Influencing Agent Spread..... | 28 |
| 8.1.1 | Fire/Discharge Event..... | 28 |
| 8.1.2 | Room/Building Geometry..... | 29 |
| 8.1.3 | HVAC Systems..... | 29 |
| 8.2 | Methods of Analysis..... | 30 |
| 8.2.1 | Building Airflow Models..... | 30 |
| 8.2.2 | CFD Models..... | 32 |
| 8.2.3 | Mathematical Models..... | 33 |
| 8.2.4 | Hybrid Approaches..... | 34 |
| 8.3 | Summary..... | 34 |
| 9.0 | TEST METHODS FOR QUANTIFYING THE IMPACT OF AGENTS ON MATERIALS..... | 35 |
| 9.1 | Enclosure Test Scenarios..... | 35 |
| 9.1.1 | Norwegian Extinguisher Tests..... | 35 |
| 9.1.2 | NRC Extinguisher Tests..... | 37 |
| 9.1.3 | Cable Fire Scenario..... | 37 |
| 9.2 | Specific Measurement Techniques..... | 39 |
| 9.2.1 | Gas Concentrations..... | 39 |
| 9.2.2 | Humidity..... | 41 |
| 9.2.3 | Physical Impact Tests..... | 41 |
| 9.2.4 | Deposition Measurements..... | 42 |

| | | |
|---|--|-----|
| 9.2.5 | Suspended Powders and Liquids in Air | 43 |
| 10.0 | DISCUSSION OF TEST PARAMETERS | 43 |
| 10.1 | General Approach to Assessing Extinguisher Impact | 43 |
| 10.2 | Exposure of Representative Materials to Environments Simulating Post-Extinguisher Discharge..... | 44 |
| 10.3 | Measurements of the Deposition and Exposure on Objects Within and Outside of the Extinguisher Spray Pattern..... | 44 |
| 10.4 | Exposure of Representative Materials Within and Outside of the Extinguisher Spray Pattern..... | 45 |
| 10.5 | Discussion of Approach and Direction of Testing..... | 46 |
| 11.0 | Proposed Test protocols and Supporting rationale | 47 |
| 11.1 | Test Enclosure..... | 47 |
| 11.2 | Materials to be Tested..... | 48 |
| 11.3 | Extinguishers to be Tested | 49 |
| 11.4 | Physical Impact Tests | 49 |
| 11.4.1 | Physical Impact Test Variables..... | 51 |
| 11.4.2 | Physical Impact Test Apparatus and Procedures..... | 51 |
| 11.5 | Non-Fire Exposure Tests | 53 |
| 11.5.1 | Non-Fire Exposure Test Variables and Parameters..... | 53 |
| 11.5.2 | Non-Fire Exposure Apparatus | 55 |
| 11.5.3 | Non-Fire Exposure Test Procedure..... | 56 |
| 11.6 | Fire Exposure Tests..... | 56 |
| 11.6.1 | Fire Scenarios | 56 |
| 11.6.2 | Fire Exposure Test Variables and Parameters | 57 |
| 11.6.3 | Fire Exposure Apparatus | 59 |
| 11.6.4 | Fire Exposure Test Procedure..... | 59 |
| 11.7 | Conservator Assessment of Exposed Materials..... | 60 |
| 12.0 | REFERENCES | 62 |
| 13.0 | BIBLIOGRAPHY..... | 67 |
| APPENDIX A – EFFECTS OF AMBIENT CONDITIONS, FIRE, AND FIRE EXTINGUISHING AGENTS ON COLLECTION MATERIAL..... | | A-1 |
| APPENDIX B – TEST SPECIFICATIONS..... | | B-1 |

GLOSSARY AND ACRONYMS

ABM – Norwegian Archive, Library and Museum Authority

Accretion – an increase by natural growth or by gradual external addition

Agglomeration – the combination by clumping of individual particles caused by heat, humidity, or chemical reaction

Artifact – a human-made object which gives information about its creator and user

Bloom – whitish, powdery coating

Blotchiness – having spots or blots on a surface

CBRN – chemical, biological, radiological, and nuclear

CFD – Computational fluid dynamics

Charring – to burn slightly and cause damage to the surface of the object (affecting the color of the object)

Clean agent – fire extinguishing agents that vaporize readily, are electrically nonconductive, and leave no residue

Cockling – wrinkling, puckering, or rippling

Collections – prehistoric and historic objects, works of art, scientific specimens, religious objects, archival documents, archaeological artifacts, library media, and cultural, materials assembled according to a rational scheme and maintained for the purpose of preservation, research, study, exhibition, publication, or interpretation

COMIS – building air flow and contaminant dispersal model developed by Lawrence Berkeley National Laboratory.

Conservation – the professional practice of examination, documentation, treatment, and preventative care devoted to the preservation of cultural property

Conservator – one who practices conservation

CONTAM – building air flow and contaminant dispersal model developed by the National Institute of Standards and Technology

Contraction – the act of decreasing (something) in size or volume

Crazing – to become minutely cracked or have surface markings, as a ceramic glaze

Cultural Resource Properties – buildings, structures, sites, or portions thereof that are culturally significant or that house culturally significant collections for museums, libraries, and places of worship

Deformation – alteration in the shape or dimensions of an object as a result of the application of stress to it

Deposition – the mechanism for particles to settle onto a horizontal or vertical room surface

Desiccation – the process of extracting moisture; dehydration

Dilation – enlargement or expansion (as in an object)

Discoloration – a soiled or faded/stained appearance

Distortion – the alteration of the original shape (or other characteristic) of an object/material

Dry chemical – a powder used for fire extinguishment composed of very small particles, ammonium phosphate-based for multipurpose extinguishers, with added particulate matter to enhance discharge characteristics

Embrittlement – hardening and weakening of a solid substance due to exposure to extreme conditions

Ethnographic collection – collection related to an individual culture

Expansion – the act of increasing (something) in size or volume

FDS – Fire Dynamics Simulator, a fire phenomenon-specific CFD code developed by the National Institute of Standards and Technology

Feathering – blurring of the edges of a feature

Fissure – a long narrow depression (microcrack) in a surface

FLIR – Forward-Looking Infrared camera

FLUENT – commercially available CFD code

FMRC – Factory Mutual Research Corporation (now FM Global)

FPA – Fire Protection Association (UK)

FPRF – Fire Protection Research Foundation, affiliated with the US National Fire Protection Association (NFPA)

FTIR – Fourier Transform Infrared Spectroscopy

Gelatinization – a transition process, during which particles break down into a jelly-like substance; a mixture of polymers-in-solution

Gilding – a coating used to embellish an object/material; thin layer covering

HEPA – High efficiency particulate air (filter)

HFC – hydroflurocarbon

IAQ – Indoor air quality

IMO – International Maritime Organization

ISE – Ion Specific Electrodes

kW – kilowatt

Matte – having a dull or lusterless surface

MERV – Minimum efficiency reporting value for air filters

MSMS – Magnetic Sector Mass Spectrometer

Neat agent – agent discharged alone without abnormal environmental or fire effects

NFPA – National Fire Protection Association (US)

NIKU – Norwegian Institute for Cultural Heritage Research

NIR-TDL – Near Infrared Tunable Diode Laser Spectroscopy

NRC – National Research Council of Canada

Preservation – the act or process of applying measures necessary to sustain the existing form, integrity, and materials of a historic building or structure

Restoration – the act or process of accurately depicting the form, features, and character of a property as it appeared at a particular period of time by means of removal of features from other periods of its history, reconstruction of missing features from the restoration period, and repair of damaged or altered features from the restoration period

RH – relative humidity

RNDCH – Riksantikvaren Norwegian Directorate for Cultural Heritage

Scorching – discoloration caused by heat

Sinking – a concave indentation

Solubilizing – make soluble (dissolve)

Stabilization – attempt to maintain integrity of cultural property and minimize deterioration

Stiffening – a process causing rigidity or loss of suppleness, due to loss of moisture, as in old leather

Swelling – an increase in the size or a change in the shape of an object, usually due to humidity or wetness

Tarnishing – make dirty or spotty, as by exposure to air or air contaminants

TDP – Thermal decomposition product

Tempera – a painting technique using an egg-water or egg-oil emulsion as the binder

Translucent – partially clear; an object/material which allows diffused light to pass through

UL – Underwriters Laboratories Inc.

USCG – United States Coast Guard

Weeping – dripping or oozing liquid

EXECUTIVE SUMMARY

Portable fire extinguishers and their associated fire extinguishing agents play an important role in reducing the impact of fire on cultural resource collections. A fire which can be extinguished with a portable extinguisher in its incipient stage will not grow to threaten adjacent materials. While conservators are well versed in the effects of moisture and water on collections, little data is available on the effects of other non-water based extinguishing agents. To fully evaluate the appropriateness of an extinguisher, its extinguishing effectiveness should be compared to the potential collateral damage to collection materials from the agent and its thermal decomposition products. Such contact with collection materials can occur by overspray during firefighting efforts or the direct spraying of collection materials in an act of vandalism.

This project is intended to quantify the impact of discharging portable fire extinguisher agents on cultural resource materials. The results can then be used by the NFPA Technical Committee on Cultural Resources (NFPA 909 and 914) to provide users with guidance on extinguisher selection. Phase I of the project included a comprehensive literature review and the development of prototype specifications and procedures to test the effects of extinguishers. In an anticipated Phase II, the test specifications would be validated and a final test specification produced. The results of Phase I are presented in this report.

In order to understand extinguisher agents, a detailed review of portable fire extinguishers was performed. The characteristics of multi-purpose (ABC) dry chemical, carbon dioxide, clean agent halocarbon, and water mist extinguishers are documented. Both agent and collection material characteristics were identified. While the effect of water/moisture on materials is well known, the effects of other agents are not well known. This supports the need for the testing proposed in this project.

In order to establish the fire protocol in the test specification, early stage fire scenarios were assessed. A fire loss review of museums, libraries, and other heritage and cultural buildings revealed that fires are most likely to involve ordinary, solid combustibles. A fire size on the order of 350 kW using a standardized wood crib was selected as a representative fire threat.

Test and measurement techniques were identified. Tradeoffs were analyzed in terms of a detailed, scientific approach compared to ad hoc discharge tests. A middle ground was adopted, with the goal to provide a cost-effective, repeatable test method using actual collection materials. Three basic tests were recommended, including physical impact tests, non-fire exposure tests, and fire exposure tests. A prototype test specification was developed based on material and agent variables. Anticipated agent effects were considered in specifying the test set up, procedures, and instrumentation.

In anticipation of data which will be derived in testing, a spreadsheet was created that provides a preliminary, generic description of collection materials and known environmental impacts. The categories are generally aligned with specialty areas of conservation and collections.

1.0 INTRODUCTION

Portable fire extinguishers and their associated fire extinguishing agents play an important role in reducing the impact of fire on cultural resource collections. A fire which can be suppressed with an extinguisher in its incipient stage will not grow to threaten adjacent materials. These may be valuable collections or the structure housing the resources which itself may be of cultural significance.

The acceptance of fire protection systems in the museum setting required a rather lengthy period of education among all stakeholders on the risk/benefits of such systems. In particular, the use of water in sprinkler systems to suppress fires had to be weighed against potential water damage [Morris, 1991]. While conservators are well versed in the effects of moisture and water on collections, little data are available on the effects of other extinguishing agents. Extinguishing effectiveness should be compared to the mechanical, physical, and chemical impacts of an agent on cultural materials. The potential collateral damage from agent overspray, or potential misuse of extinguishers in spraying collection materials, should be assessed. The byproducts of the agent when used to extinguish a fire should also be considered.

The Fire Protection Research Foundation (FPRF) is supporting a project investigating these concerns. It was initiated by the NFPA Technical Committee on Cultural Resources, which produce standards on the Protection of Cultural Resources, NFPA 909 [NFPA, 2007a] and Historic Structures, NFPA 914 [NFPA, 2005]. This committee desires to quantify the impact of discharging portable fire extinguisher agents on sensitive materials. The motivation of this project is to provide the cultural resource community with options and tradeoffs associated with portable extinguisher agents, the effectiveness of the agents on different types of fires, and the collateral, non-fire impact of the agent. Phase I of the project includes a comprehensive literature review, and the development of prototype specifications and procedures to test the effects of extinguishers. The prototype specifications would then be finalized in a follow-on Phase II test validation program. A standard test method for use globally by the fire protection and cultural resource community would then be available.

The project is intended to determine the impact of portable fire extinguishers on cultural resource collections. This can encompass any material deemed to have significance. Since the project overlaps two very diverse areas, fire protection and conservation, a glossary is included. The terminology and meanings of cultural resource collections and cultural resource properties used by NFPA 909 and 914 are used in this report and included in the glossary.

The four explicit tasks of the literature review were:

1. Characterize early stage fire scenarios in museum spaces;
2. Characterize the chemical composition of extinguishing agents required by NFPA 10, *Standard for Portable Fire Extinguishers* [NFPA, 2007b] for these spaces under normal conditions, and their thermal decomposition products at elevated temperatures and humidity;
3. Assemble data and models that may be used to estimate dispersion and concentration of extinguisher agents in typical multi-room museum spaces; and

4. Identify existing test methods and data related to the impacts of extinguishing agents on materials with a special focus on those relevant to cultural resource collections.

Section 2 describes general fire threats and the extinguishers used to combat these threats. Section 3 describes anticipated early stage fire scenarios, based on specific cultural collection fire loss and fire growth fundamentals. More detailed analysis of the agent characteristics are provided in Section 4.1. In order to make an assessment of collateral damage impact, collection materials are identified in Section 4.2. A preliminary assessment of environmental and agent effects is made in Section 5, and outlined in Appendix A. A matrix of fire extinguishment impact is presented in Section 6 and Appendix A. Dispersion models are reviewed in Section 8. Existing test methods are analyzed in Section 9, and discussed in Section 10. Finally, a prototype test procedure and specification is outlined in Section 11 and Appendix B.

2.0 PORTABLE FIRE EXTINGUISHER USE FOR PROTECTING CULTURAL COLLECTIONS

Fire extinguishers are designed to combat incipient fires before they grow large and are an important element of fire protection for facilities housing cultural collections. A staff trained in fire/security issues is generally available in such facilities, which can improve the likelihood of rapid detection and control of incipient fires using portable extinguishers. The effectiveness of agents is well characterized by NFPA 10 and Underwriters Laboratories Inc. UL 711, *Standard for Rating and Testing of Fire Extinguishers* [Underwriters Laboratories Inc., 2005]. The objective of this study is to quantitatively characterize the potential for and characteristics of agent non-fire collateral damage, and agent thermal decomposition products.

NFPA 909 requires that portable fire extinguishers for new construction, alterations, and additions be selected, installed, and maintained in accordance with NFPA 10. However, the standard does not provide any quantitative guidance on the selection of extinguishers for protecting collections. Annex material notes that:

“...The extinguisher should be of a kind intended for the class of fire anticipated. Multi-class portable extinguishers are available that remove any doubt whether the correct extinguisher is being used.”

There are special hazard areas and operations which require portable extinguisher protection (e.g., kitchens, areas where hot work is performed), but these are not the areas of most interest for this project. The emphasis is on the protection of collections.

NFPA 10 is not particularly helpful in terms of specific guidance for protection of cultural collections and property. It provides general guidance on the selection of extinguishers. Along with UL 711 it defines the types, capabilities, and requirements for portable extinguishers. Fires are classified in NFPA 10 according to the following hazards:

- **Class A fires** are fires in ordinary combustible materials, such as wood, cloth, paper, rubber, and many plastics.
- **Class B fires** are fires in flammable liquids, combustible liquids, petroleum greases, tars, oils, oil-based paints, solvents, lacquers, alcohols, and flammable gases.

- **Class C fires** are fires that involve energized electrical equipment.
- **Class D fires** are fires in combustible metals, such as magnesium, titanium, zirconium, sodium, lithium, and potassium.
- **Class K fires** are fires in cooking appliances that involve combustible cooking media (vegetable or animal oils and fats).

The classification of fire extinguishers consists of a letter that indicates the class of fire on which a fire extinguisher has been found to be effective. Fire extinguishers classified for use on Class A or Class B hazards have a rating number preceding the classification letter that indicates the relative extinguishing effectiveness; increasing size fire threats can be extinguished with units having greater numerical ratings. Extinguishers listed for the Class C fires do not have a numerical rating. They may not contain an agent that is a conductor of electricity, except that distilled or de-ionized water may be used in a water mist extinguisher.

The Classes of fire relevant to collections are Class A, B and C. Rooms or areas of occupancy are classified generally as being light (low) hazard, ordinary (moderate) hazard, or extra (high) hazard. No quantification of these threat levels is provided in NFPA 10, although qualitative descriptions of these hazard classifications are given. Using the guidance in NFPA 10, collection areas would generally (but not always) be considered light (low) hazard areas. For light hazard occupancies, a portable extinguisher having a minimum 2-A rating must be provided subject to maximum coverage area and travel distance requirements. If there are anticipated Class B or C hazards, extinguishers with these ratings must also be provided; this can be achieved with a “multi-purpose” extinguisher having more than one letter classification, or through provision of separate A or B extinguishers. No qualification of Class B hazards for the collection environment is given. All Class C extinguishers also have an associated Class A and/or B rating, since a Class C listing only requires that the agent is electrically non-conductive and does not require any additional fire testing.

There are many types of extinguishers available to combat various fire hazards. This project will focus on commercially available units appropriate for use in a collection setting. Since NFPA 10 requires a minimum 2-A rating, characteristics for this rating are provided. In review with the project Technical Panel, it was decided to focus on the following extinguishers and agents:

1. ABC (multi-purpose) dry chemical – this extinguisher provides capability for all types of fires anticipated in general collection environments, eliminating any doubt by staff on the correct extinguisher to use. Listed portable extinguishers having a 2-A:10-B:C rating have a capacity between four and five pounds. They have a discharge duration of 14 seconds and a discharge range of 3.7–5.5 m (12–18 ft). The dry chemical leaves a powder residue. Dry chemicals used only for Class B hazards are not included in this project.
2. Carbon dioxide (CO₂) – CO₂ is an inert, gaseous agent. It is effective only for Class B and Class C hazards. It is not considered effective on Class A materials. Listed five pound units have a 5-B:C rating while ten pound units have a 10-B:C rating. They have a discharge duration of 10 seconds and a discharge range of 0.9–2.4 m

(3–8 ft). There is concern about cold shock to materials when this extinguisher is discharged, and possible mechanical damage from agent discharge.

3. Halocarbon type agents – these are clean agents intended to replace halon 1211. These include:
 - a. Hydrochlorofluorocarbon (HCFC)
 - b. Hydrofluorocarbon (HFC)

Only two agents currently are used in UL Listed clean agent fire extinguishers rated for ABC hazards: HCFC Blend B (Halotron 93% HCFC 123), and HFC-236fa (FE-36). Listed Halotron 34.1 kg (15.5 lb) units have a 2-A: 10-B:C rating. They have a discharge time of 14 seconds and a discharge range of 3.7–5.5 m (12–18 ft). The Listed multipurpose 29.2 kg (13.25 lb) FE-36 extinguisher has a 2-A: 10-B:C rating. It has a discharge duration of 13.5 seconds and a discharge range of 4.3–4.9 m (14–16 ft). Clean agent extinguishers may cause mechanical damage when discharged.

Other halocarbon agents may be used. Halon 1211, listed for ABC use, is being phased out for environmental reasons. UL will no longer accept the submittal of new or revised products covered under the liquefied Gas-type Extinguisher Category [Underwriters Laboratories, 2009]. UL is withdrawing the *Standard for Halogenated Fire Extinguishers*, UL 1093. HFC-227ea (FM-200, FE-227) is used in Listed extinguishers rated for B:C hazards. These extinguishers are not considered in this project.

4. Water mist, 2-A:C – water stored in a fire extinguisher is pressurized to 100 psi using distilled water discharged as a fine spray. A 9.5 L (2.5 gal) unit has a discharge duration of 80 seconds and a discharge range of 3–3.7 m (10–12 ft). Since it is discharged as a fine spray, potential collateral water damage may be reduced, depending on the spray momentum. There may be residual water/moisture, but there is no powder residue. While the unit is pressurized with nitrogen, the resulting spray pattern is in a mist form with low momentum.

Since collections are the primary focus of the study, special hazard extinguishers are excluded from the study. These agents included wetting agents, foam, Class B dry chemicals (potassium bicarbonate, sodium bicarbonate), wet chemical (e.g., Class K) and dry powders used for Class D metal fires. It may be appropriate to use special hazard extinguishers in particular areas of historic or cultural resource properties. For example, kitchens may have a Class K potassium acetate extinguisher. These should be installed in accordance with NFPA 909, 914, and 10.

3.0 EARLY STAGE FIRE SCENARIOS

In an effort to develop the fire test criteria, the fire loss history in cultural collections was analyzed to assess potential fire threats. Methods used in fire hazard assessments were reviewed for potential applicability for agent testing. Basic UL rating criteria are also included as part of the fire scenario assessment.

3.1 Fire Loss Review

Early stage fire scenarios in museum spaces are best identified through loss history and overall assessment of the hazards. The fire loss history was reviewed for indications of appropriate scenarios. Fires in museums, libraries and other heritage and cultural buildings can be particularly devastating, causing damage from heat, as well as depositing soot and other combustion products. This can irreparably damage artifacts and the historic buildings in which they are often stored.

Four primary surveys and compilations were reviewed to determine the causes of museum, library and heritage building fires and the associated first materials ignited.

Flynn compiled loss data from assembly occupancy fires that occurred between 2000 and 2004 [Flynn, 2007]. The data was obtained from the National Fire Incident Reporting System (NFIRS) and NFPA survey data. Libraries and museums are included in this occupancy classification, and account for 13% of these fires. Caution should be used in interpreting this data since libraries and museums represent a small sample sector of the survey sample. According to this survey, the leading cause of fires was contained trash or rubbish, which accounted for 34% of fires, but caused only \$100,000 in loss. Cooking fires were listed as the second most likely cause of fires (14%) and caused \$3.3 million in damage. Intentional fires were the third most likely (13% of fires) but caused far and away the most damage, with a reported \$23.3 million in damage. Heating equipment also accounted for a sizable number of fires (7%), accounting for \$9 million in loss. Flynn also compiled data on the first item ignited. Again, contained trash or rubbish was the most common item first ignited, accounting for 34% of fires. Confined cooking fires accounted for 13% of fires, and electric wire or cable insulation accounted for 5%.

Ahrens compiled a list of annual averages of structure fires in museum, art galleries and libraries (among other occupancies) from 1980 to 1997 [Ahrens, 1999]. The data were obtained from NFIRS and NFPA survey data. For museums and art galleries the most likely cause of fires was electrical distribution, accounting for an average of 22 fires (25%) and \$560,000 in loss per year. Incendiary or suspicious fires were the second most common, with an average of 17 fires (19%) and \$530,000 in loss per year (Table 1). For libraries, incendiary or suspicious fires accounted for a yearly average of 79 fires (40%) and \$4,226,000 in damages. Electrical distribution was the second most likely cause, accounting for 40 fires (20%) and causing \$296,000 in damages annually.

Annex B from NFPA 909 also has information of causes of fires in museums, art galleries, and libraries [National Fire Protection Association, 2005]. The data were similar to what was analyzed by Ahrens, since it is the same source data. For museums and art galleries from 1980 to 1998, electrical distribution accounted for an average of 21 (25%) annual fires while causing an average of \$560,000 in damage. Incendiary fires accounted for 16 (19%) annual fires and cause an average of \$530,000 in damage. For libraries from 1980 to 1997, incendiary fires were the most common, accounting for 78 (40%) annual fires and an average of \$4,018,200 in damages. Electrical distribution was the second most likely cause accounting for 38 (20%) annual fires and an average of \$281,400 in loss. NFPA 909 also has information on causes of religious occupancy fires. Incendiary fires accounted for 510 (32%) annual fires and caused an

average of \$18.4 million in annual loss. Electrical distribution was the second most likely cause, accounting for 230 (15%) annual fires and causing an average of \$5.8 million in loss. Heating equipment and open flames, embers and torches accounted for 180 and 120 (12% and 7%) annual fires, respectively were also likely causes of fire in places of worship.

**Table 1. Causes of Structure Fires in Museums or Art Galleries 1980–1997
Annual Averages [Ahrens, 1999]**

| Cause | Fires | Civilian Deaths | Civilian Injuries | Direct Property Damage |
|-------------------------------------|--------------------|------------------------|--------------------------|-------------------------------|
| Electrical distribution | 22 (24.5%) | 0 (NA) | 0* (22.3%) | \$560,000 (27.4%) |
| Incendiary or suspicious | 17 (18.6%) | 0 (NA) | 0 | \$530,000 (26.0%) |
| Other equipment | 10 (10.9%) | 0 (NA) | 0* | \$261,000 (12.8%) |
| Open flame, ember or torch | 8 (9.1%) | 0 (NA) | 0* (14.3%) | \$41,000 (2.0%) |
| Heating equipment | 7 (8.0%) | 0 (NA) | 0* (19.9%) | \$528,000 (25.8%) |
| Smoking materials | 7 (7.5%) | 0 (NA) | 0 | \$13,000 (0.7%) |
| Cooking equipment | 6 (7.2%) | 0 (NA) | 0 (0.0%) | \$26,000 (1.3%) |
| Exposure (to other hostile fire) | 4 (4.4%) | 0 (NA) | 0 (0.0%) | \$55,000 (2.7%) |
| Natural causes | 4 (4.0%) | 0 (NA) | 0 | \$22,000 (1.1%) |
| Appliance, tool or air conditioning | 3 (3.6%) | 0 (NA) | 0* (30.8%) | \$2,000 (0.1%) |
| Other heat, flame or spark | 1 (1.4%) | 0 (NA) | 0* (6.5%) | \$3,000 (0.2%) |
| Child playing | 1 (0.8%) | 0 (NA) | 0 (0.0%) | \$0* (0.0%) |
| Total | 89 (100.0%) | 0 (NA) | 1 (100.0%) | NR**(100.0%) |

* Not zero, but rounds to zero.

** Not reported

Scoones compiled a list of 27 library and museum fires that occurred between 1986 and 1991 in the UK [Scoones, 1991]. Of these fires, 17 were arson, or suspected arson (63%) and caused an estimated loss of £67,073,965. Electrical fires were the next most common with 5 fires (19%) causing an estimated £1,415,000 in loss. The remaining fires were either of unknown origin or still under investigation, and caused an estimated £1,585,000 loss.

In addition to the broad statistics given above, there is a large quantity of data on individual large loss fires. Below is a brief list of major loss fires, their causes (if known), and the amount of damage.

- Library of Government at the University of Michigan. 1950. Arson. \$637,000 in damages
- State Library of Michigan. 1951. Loss of \$2,850,000, two floors of the building had to be completely removed.
- Monastic Church of St. Ulrich, Kreuzlingen. 1963. Total Loss.
- National Museum of Natural History, Washington, D.C. 1965. Fire started in exhibit case. Destroyed seven specimens of scientific value.
- National Museum of American History, Washington, DC. 1970. Electrical short in a computer exhibit. Over \$1 million in damages.
- Roguemont Castle. 1975. Major Damage.
- Smithsonian Institution Support Facility. 1976. \$150,000 in damages.
- Church and monastic buildings of the Beinwill Monastery. 1978. Major Damage.
- Museum of Modern Art, Rio de Janeiro, Brazil. 1978. Electrical fire in an improvised display room. Destroyed over 950 works of art including masterpieces by Van Gogh and Picasso.
- San Diego Aerospace Museum, San Diego, CA. 1978. Arson. Near total loss.
- Pleujouse Castle (10th century). 1980. Total Loss.
- Hollywood Regional Library. 1982. Arson. Over \$5 million in damages.
- Bailiff's office at Einsiedeln Monastery. 1983. Major Damage.
- Byer Museum of Art, Evanston, IL. 1984. Electrical fire in wall spread into museum display area. \$3 million in damages.
- Huntington Gallery, San Marino, CA. 1985. An electrical fire in an elevator smoldered and resulting smoke then spread to all floors when the elevator doors opened. Smoke spread throughout much of the building including via the HVAC system. Heat damage was limited to one painting, but there was \$1.5 million in total damages. This was mostly a result of smoke damage.
- Los Angeles Central Library. 1986. Arson. \$23 million in loss including 350,000 books totally destroyed and another 700,000 sustained water damage.
- Library in USSR Academy of Science, Leningrad, Russia. 1988. Electrical defect in newspaper collection storage room. 400,000 rare or unique works destroyed, another 3.6 million books water damaged due to 19 hours of firefighting.
- Louisiana State Museum, New Orleans. 1988. Torch ignited downspout during renovation work. \$5 million in damages.
- Norwich Central Library, Norwich, England. 1994. Faulty wiring in a bookcase. 350,000 books and priceless manuscripts (some dating to the 11th century) were lost.
- Virginia Library, Hampton, VA. 1996. \$4.5 million in damages.

- Daniel Boone Dwelling, Missouri. Defective wiring. \$40,000 in damages.

Sources: [National Fire Protection Association, 2005], [Jenkins, 1970], [Morris, 1991], [Wilson, 1991], [Rohlf & Favre, 1991]

In general, it appears the most likely causes of fires in museums, libraries and other historical and heritage buildings are arson and electrical. Fires in ordinary combustibles are also a factor, both in terms of ignition location (e.g., trash) but also as a means of fire growth for electrical and arson fires. Electrical fires must have combustibles in contact with the energized source. A detailed analysis of arson fires was not performed. Presumably these were initiated using Class A or B materials. Most arson fires, due to the goal of causing damage, begin or rapidly grow to larger fires, even in the early stages. This is evidenced by some of the listed fires, where arson usually caused the most damage. Electrical fires usually begin by smoldering within walls or object that house wiring, circuits or other electrical equipment. This can be seen in the Byer Museum fire of 1984, where a fire smoldered in the wall for an unknown amount of time and then spread out of the wall destroying two floors of the museum [National Fire Protection Association, 2005]. Electrical fires usually start small, with an electrical short or spark igniting a Class A item, such as wall coverings, or trash, or a display item. This item then becomes involved, and from this item the fire spreads to other items. Examples of these initial items could be a rubbish pile as described in one of the surveys [Flynn, 2007], paintings, exhibit construction, combustible insulation, or wood paneling. These small Class A fires that are directly ignited from the electrical source would generally characterize an early stage fire with an electrical source. Similar to electrical fires, fires caused by torches or other hot work generally ignite Class A materials.

3.2 Fire Hazard Analysis Techniques

Chapter 9 of NFPA 909 provides a performance-based design option as permitted in the Standard. The process includes the establishment of design fire scenarios. These are used in analyses to determine an acceptable level of protection. Design fire scenarios must represent challenging, but realistic, situations in terms of fire location, early rate of growth, overall fire severity, and smoke generation. The emphasis of NFPA 909 is on life safety and property protection. Small fire scenarios are generally linked to early warning fire detection criteria in unoccupied areas; the small, incipient fire which is detected in the early stages and suppressed with an extinguisher is not emphasized per se.

Example fire scenarios for cultural collections are provided in Table 2. A 200–500 kW fire is a typical fire size selected for this scenario since it represents those fires in the incipient stage capable of being suppressed with a portable extinguisher.

Testing performed in Norway also used a characteristic fire for testing that was performed on extinguisher use in museums and libraries. For these tests, stacks of wood ignited by kerosene were used to represent the early stage fires [IGP AS, 2000]. A more detailed discussion of this scenario is provided in Section 9.1.1.

Table 2. Example Design Fires used for Fire Risk Assessment of Cultural Collection Facilities

| Design Fire No. | Peak Fire Size (kW) | Growth Rate (α) | Steady Burning Duration (min) | Total Burning Duration (min) | Representative Fuel Loading |
|------------------------|----------------------------|--|--------------------------------------|-------------------------------------|--|
| 1 | 200 | Medium | 2–3 | 7 | Small miscellaneous combustibles, small garbage can, small artwork display |
| 2 | 500 | Medium | 5 | 12 | Small miscellaneous combustibles, several trash bags, small artwork display. |
| 3 | 1,000 | Medium-Fast | 10–14 | 20 | Small room fire, moderate combustibles, medium-sized exhibit, limited furnishings |
| 4 | 3,000 | Fast | 20 | 30 | Medium room fire, moderate combustibles, large display, multiple furnishings. |
| 5 | 5,000 | Fast | 25 | >30 | Large room fire, moderate combustibles, large display, multiple furnishings. |
| 6 | 10,000 | Fast | >30 | >30 | Medium gallery/period-room, storage room, or open office fire, full-room fire involvement. |
| 7 | 15,000 | Fast | >30 | >30 | Large gallery/period-room, storage room, or open office fire, full-room fire involvement. |
| 8 | 5,000 | Ultra-fast | 15 | 20 | Flammable liquid/plastics fire, subsequent fire spread to ordinary combustibles. |
| 9 | 15,000 | Ultra-fast | >30 | >30 | Large gallery/period-room fire, full-room fire involvement, rapid growth rate. |

3.3 UL Rating Fire Threats

Extinguishers are designed in various sizes, with increasing numerical ratings associated with increasingly larger fire threats.

UL classifies extinguishers for Class A ratings using two Class A fire scenarios. One test involves the extinguishment of a wood “crib,” a multi-layer arrangement of wood sticks. The other involves a wood panel ignited by wood shavings (excelsior). As noted in Section 2, the minimum rating of Class A extinguishers in a light hazard occupancy is 2-A. The wood crib arrangement for a 2-A fire test is 13 layers of 5 sticks each. The sticks are 38 by 38 mm trade size (2 x 2 (1.5 x 1.5 in.), 635 mm long (25 in.)) kiln dried spruce or fire lumber. For test fire scenarios, a 1-A fire may also be considered. A 1-A crib has twelve layers of six sticks, each

stick 500 mm (20 in.) long. The 2-A crib is ignited by a 535 x 535 x 100 mm (22 x 22 x 4 in.) pan located below the crib, having 2.0 L (0.5 gal) of heptane. The 1-A crib is ignited by a 400 x 400 x 100 mm (16 x 16 x 4 in.) pan having 1.1 L (0.3 gal) of heptane. The liquid fuel is ignited and burned until out. Firefighting with the extinguisher commences when the crib mass has been reduced to 55 ± 1 percent of its original mass. The extinguisher is discharged continually until the extinguisher is empty. The crib is attacked from the front at an initial distance of 1.8 m (6 ft). The operator is then permitted to reduce the distance of attack and discharge at the sides, top, and bottom of the crib. In no case is the discharge allowed to be directed to the back of the crib.

The estimated heat release rate of 2-A cribs is on the order of 1150 kW, while the 1-A crib is about 630 kW.

The wood panel arrangement for Class A fire tests consists of a solid square wood-panel backing constructed of 19 by 140 mm (0.75 by 5.50 in.) trade size sheathing of kiln dried spruce or fir. Furring strips (19 by 19 mm (0.75 by 0.75 in.) trade size clear kiln dried fir) are nailed vertically on the backing panel on 610 mm (2 ft) centers. Horizontal furring strips are then nailed on the vertical strips on 38 mm (1.50 in.) centers. This arrangement is supported by steel framework, hangers or other means that does not obstruct the flammable material. Grade No. 2 fuel oil is uniformly applied to the panel, with any excess on the floor cleaned up. A windrow of excelsior (seasoned basswood, poplar, or aspen) is placed at the foot of the panel, and a fuse of 60–120 mL (2 to 4 ounces) of heptane is poured along the front edge of the windrow, and lit in the center. For a 1-A rating, the panel is 2.45 by 2.45 m (8 by 8 ft) and 3.8 L (1 gal) of fuel oil and 4.55 kg (10 lb) of excelsior are used. For a 2-A rating, the panel is 3.05 by 3.05 m (10 by 10 ft) and 7.55 L (2 gal) of fuel oil and 9.05 kg (20 lb) of excelsior are used. Forty-five seconds after ignition, a second windrow of excelsior is pushed up to the base of the panel. This is repeated again twice, at 45 second intervals. At 3 minutes 20 seconds all remaining excelsior is to be removed. Extinguishment begins when the horizontal furring strips begin to break or at 4 minutes 30 seconds, whichever comes first. The extinguisher is discharged until the fire is out. Amount of agent used is recorded.

UL classifies extinguishers for Class B ratings using a flammable liquid fire scenario. In this test, a 50 mm (2 in.) layer of commercial grade heptanes is placed into a square steel pan. The steel pan has a thickness of at least 6 mm (0.25 in.) with a 4.8 mm (0.19 in.) thick angle to reinforce the upper edge. The area of the pan varies depending on the rating. The pan is placed on the floor of the test room, away from any walls or obstructions. The heptane is added to the pan, so that there is a 50 mm (2 in.) layer of heptane and 150 mm (6 in.) between the top of the heptane layer and the top of the pan. In order to achieve the correct height, water may be added to the pan. For a 1-B rating, a 0.23 m² (2.50 ft²) pan is used with 11 L (3.25 gal) of heptane. For a 2-B rating, a 0.47 m² (5 ft²) pan is used with 23 L (6.25 gal) of heptane. For a 5-B rating, a 1.16 m² (12.5 ft²) pan is used with 57 L (15.5 gal) of heptane. For a 10-B rating, a 2.32 m² (25 ft²) pan is used with 114 L (31 gal) of heptane. The heptane is ignited and allowed to burn for 60 seconds before attacking with an extinguisher. The extinguisher is discharged until the fire is out, and the amount of agent used is recorded. The extinguisher must discharge for at least 8 seconds. A test is considered extinguished if it does not self-reignite. A simple rule-of-thumb for the size of a Class B fire is that it is 2.5 times the rating, in square feet. For example, a 2B rating requires the extinguishment of a 5 square foot pan fire.

4.0 AGENT AND COLLECTION MATERIAL CHARACTERISTICS

4.1 Agent Characteristics

Several types of portable fire extinguishers are available to fight fires in cultural resource collections as noted in Section 2. The focus of this review is on non-water based agents, specifically dry chemical and gaseous agents. The literature indicates that the most popular dry chemical for cultural resource protection is multipurpose ABC. The gaseous agents fall into two categories, clean agents and inert gas. Three clean agents have been shown to be effective against Class A, B, and C fires and are commercially available. They include HCFC Blend B (trade name Halotron I), HFC-227ea (trade names FM-200 and FE-227), and HFC-236fa (trade name FE-36). HFC-227ea does not have a UL Listing for Class A, but has been recognized for use in aircraft cabin protection. Carbon dioxide (CO₂) is an inert gas, limited to Class B and C fires.

4.1.1 ABC Dry Chemicals

ABC dry chemical extinguishing agent contains a mixture of ingredients. The primary ingredient in all ABC extinguishers is monoammonium phosphate, typically comprising between 80-95% of the mixture by weight. It can be as low as 50% of the mixture. The remaining ingredients vary by manufacturer and can include ammonium sulphate, barium sulphate, attapulgite clay (magnesium aluminum silicate), mica (potassium aluminum silicate), silicone oil (methyl hydrogen polysiloxane), amorphous silica (precipitated synthetic zeolite), calcium carbonate, stannous octoate, and pigment/dye [Amerex, 2008; Buckeye, 2007; PyroChem, 2007]. The extinguishers are pressurized with either nitrogen or air. The agent is discharged as a fine powder. The measured particle size ranges from 25–95 µm with an average of 31 µm [Finnerty and Vande Kieft, 1997].

4.1.2 Clean Agents

HCFC Blend B (trade name Halotron) is a blend of dichlorotrifluoroethane (HCFC 123, a liquid), tetrafluoromethane (CF₄, a gas) and argon (gas). According to the manufacturer's MSDS, HCFC 123 makes up a minimum of 93% of the blend with the remaining 7% comprised of a proprietary mixture [American Pacific Corporation, 2006]. HCFCs are stored as a pressurized liquid and vaporize upon discharge.

Both HFC-227ea (1,1,1,2,3,3,3-heptafluoropropane, also called FM-200) and HFC-236fa (1,1,1,3,3,3-hexafluoropropane, also called FE-36) are single component agents. Nitrogen gas is used to pressurize the extinguisher for both agents. HFCs are stored as a pressurized liquid and vaporize upon discharge.

4.1.3 Carbon Dioxide (CO₂)

CO₂ is a single component agent that is stored as a pressurized liquid and vaporizes upon discharge. Unlike the HCFCs and HFCs mentioned in this report, CO₂ does not require the use of an inert gas (HCFC Blend B – argon, HFC-227ea and HFC-236a – nitrogen) to pressurize the extinguisher. The vapor pressure of CO₂ is sufficient to propel the agent during discharge.

4.2 Collection and Structural Materials

Cultural resources and artifacts can be made of nearly any man-made or naturally occurring material. Even modern materials are displayed as artifacts: early computers, or other rapidly developing technologies (autos/aircraft), are examples. Older materials and antiquities are more commonly identified with cultural collections. Organic material in natural history or ethnographic collections may be historically significant and the source of study.

An attempt was made to create an all-inclusive list of materials, while bounding the materials to create some form of categorization. Approaches used by the *International Council of Museums* and the *American Institute for Conservation of Historic and Artistic Works* were combined to create the following categories of cultural resource materials:

1. Architecture;
2. Ethnographic collections;
3. Glass and Ceramics;
4. Leather and related materials;
5. Metals;
6. Modern Materials and Contemporary Art;
7. Natural history collections;
8. Paintings;
9. Paper and graphic documents (including books);
10. Photographic materials;
11. Textiles and fabrics;
12. Wood and furniture; and
13. Miscellaneous materials related to protective materials and materials used for stabilization and restoration of collections and artifacts.

The spreadsheet in Appendix A provides descriptions of materials in each category. It can immediately be seen that there is cross-over. Metals are valued as objects (metal sculptures), while also used in architectural building materials. Polymers might also be included as a separate category. The categories are generally aligned with specialty areas of conservation and collections. This should facilitate the application of the data derived in Phase II.

5.0 ENVIRONMENTAL IMPACT ON MATERIALS

In order to have an understanding of the impact of fire and extinguishing agents on materials, it is important to have a basic understanding of common reactions of materials. The day-to-day environment of the cultural resource property has an impact on collections and the structure. Although there may be little direct correlation with agent or fire collateral damage, basic conservation experience provides information on the reaction of collection materials to the environment. For example, the impact of moisture will suggest how materials may react when sprayed with water mist. Susceptibility to corrosion may be important for consideration for use of either water or dry chemical agents. The following sections provide fundamental information on

environmental effects, which lead to more specific (and more limited) information on extinguishing agent and fire effects described in Sections 6 and 7.

A fire and extinguisher effects test similar to that proposed in this project has been performed by Norwegian cultural heritage organizations. Tests were conducted by the Norwegian Archive, Library and Museum Authority (ABM) and Riksantikvaren the Norwegian Directorate for Cultural Heritage (RNDCH), and carried out by COWI AS in cooperation with the Norwegian Institute for Cultural Heritage Research (NIKU). The tests were reported in 2000 [IPG AS, 2000]. Subsequently, the data was summarized and used in an overall fire extinguisher assessment published by COWI [Jensen, 2006].

Three test scenarios were used to assess nine different extinguishers/extinguishing systems. Thirteen representative test specimens were exposed in a test chamber to the following exposures:

1. Test fire (smoke), with no extinguisher discharge;
2. Test fire, extinguished, with agent subsequently discharged on the exposed samples using the selected extinguisher; and
3. No fire, agent applied to the test samples.

The following representative museum materials were selected for analysis:

1. Wood, painted using oil based paint, about 90 years old;
2. Wood, panel painted using oil based paint, about 90 years old and treated with a mixture of 1:1 beeswax:dammar resin dissolved in white spirit, one layer thick;
3. Wood, old panel newly painted in tempera;
4. Iron, 5 mm sheet with and without coating;
5. Iron, 5 mm sheet with and without coating. One layer of lacquer, 5% Paraloid dissolved in acetone;
6. Oil painting on canvas about 10 years old;
7. Oil painting on canvas about 10 years old. One layer of Laropal varnish. 1 part Laropal standard and 5 parts white spirit;
8. Leather, cowhide, tanned organically, not dyed, about 50 years old;
9. Leather, cowhide, tanned organically, not dyed, about 50 years old. One layer of Maroquin saddle soap;
10. Wool with two colors, new material;
11. Cotton, embroidered, about 40 years old;
12. Linen, embroidered, about 40 years old; and
13. Acid free cardboard, new material, about 1.8 mm (0.07 in.) thick.

The following extinguishers of interest to this project were used in the evaluation:

1. Powder (ABC ammonium phosphate);
2. CO₂;
3. Water;
4. Water mist;
5. Foam – AFFF; and
6. Foam – Emulsifying.

Details of the test set up and procedures are provided in Section 9.1.1. The effects observed in these tests are included in this section. Neat agent effects from tests are described in Section 6.3.1. Combined effects are described in Section 7.

5.1 Environmental Effects

5.1.1 Humidity

Humidity and overall moisture are critical to conserving cultural artifacts. Most museum objects are composed entirely, or in part, of materials which react to a change in moisture content in air. Most artifacts have a very small optimum storage range of humidity. If artifacts such as paper, photographs, or fibers are too moist or too dry, they can be susceptible to mold, shrinkage, loss of flexibility, embrittlement, and cracking. At high humidity, metals can tarnish and corrode [Johnson and Horgan, 1979]. Appendix A provides data on humidity effects. Photographs and paper are most susceptible to humidity. Wood is moderately susceptible. Stone and glass are least susceptible.

5.1.2 Temperature

Temperature control is important. An increase in temperature accelerates the rate of chemical reactions; the rate of reaction can double for each 10°C (50°F) of temperature increase [Johnson and Horgan, 1979]. High ambient temperatures particularly affect leather and other organic materials. In particular, they may lose mechanical properties; fibrous materials lose flexibility and become stiff and embrittled. Waxes and resinous coatings may soften to solidify and become brittle, increasing the chances of fracture and cracking.

It is postulated that rapid temperature change may cause physical damage to materials. In particular, rapid change from hot to cold (i.e., from a CO₂ extinguisher discharge) may cause glass or ceramics to fracture, and may cause damage to paintings and painted surfaces. Low temperature can cause severe damage to paintings and painted surfaces. The glass transition temperature (T_g) for oil paints is around -5°C to -10°C (-41°F to -50°F), for alkyds around 0°C (32°F), and acrylics around 5°C to 10°C (41°F to 50°F). These paint films will be brittle when subjected to temperatures below their T_g [Mecklenburg, 2009].

5.1.3 Ambient Light

Collections may degrade as a result of light. Exposure to light in all forms may cause a chemical reaction within the molecular level of the artifact [Texas Historical Commission, undated]. UV light is considered the most harmful. Damage is cumulative and irreversible. Paper, photographs, watercolors, textiles, and artwork are particularly sensitive and susceptible to fading. Oil paintings, wood, and leather are less sensitive to light. Metal, glass, ceramics, and stone are least sensitive.

For film products, plexiglass-type glazing is used to filter UV light.

5.1.4 Indoor Pollutants (Chemicals)

Oxidative and acidic molecules found in the outside environment surrounding archival collections can cause collection deterioration. Examples include ozone, sulfur dioxide, and oxides of nitrogen. These pollutants also damage buildings and statues. Compounds can also be produced indoors by a variety of materials and furnishings, as well as by heating equipment and various appliances. Deleterious pollutants and chemicals produced inside may result from deteriorative agents which emit chemicals such as formaldehyde, peroxides, formic acid, and acetic acid. These can be emitted by wood, plywood, particle board and chip board. Protein-based glues and wool can yield sulfides. Fumes from an underground parking area can cause elevated interior levels of oxides of nitrogen. Sunlight can be responsible for increased photolytic reaction rates, resulting in concentrations of oxidative and acidic molecules such as ozone, peroxides, nitric acid and other nitrogen-containing molecules. Acids and other harmful molecules may also migrate from adjacent acidic materials [Druzik, 2003].

Fire particles of dust and other small particles can cause a great deal of damage to certain artifacts [Johnson and Horgan, 1979]. Environmental air pollutants include particulates and gases [Texas Historical Commission, undated]. Particulates include dust, soot, and pollen which can chafe, soil or otherwise blemish artifacts. Gaseous pollutants such as ozone, peroxides, nitrogen oxide, and sulfur dioxides can chemically react with other materials to form harmful acids. The acid can form within the artifact itself or migrate from one material to another.

5.2 Neat Agent Effects

The review of neat agent discharges reflects the possible impact of the agent when discharged in a non-fire event. This scenario could include accidental discharges or acts of vandalism.

5.2.1 ABC Dry Chemical

The ABC agent is discharged as a fine powder, which can eventually settle on nearby surfaces. In the presence of moisture, monoammonium phosphate, the main component of the agent, is slightly acidic and has mild corrosive properties [Pyro-Chem, 2008]. As monoammonium phosphate is hygroscopic, moisture can be easily attracted through direct contact with water or humidity. To avoid any potential damage, the powder residue should be removed promptly.

The literature search did not provide an extensive amount of information detailing the effects of the ABC residue on exposed materials. The Norwegian test report did provide useful information [Jensen, 2006]. The materials were exposed to the ABC agent for a period of 24 hours before being brushed away or removed with water. No visual change was noted for any of the materials during the initial inspection. Iron samples showed signs of corrosion after one month. In this case, the residue was brushed away instead of being removed with water so it was assumed that residual water used in other cleaning processes did not cause the corrosion. The researchers did note that it was more difficult to remove the powder residue from leather and textiles; they had to be rinsed. It was concluded that there was not much chemical damage to the sample materials. This information appears to contradict reports from the field where objects exposed to dry chemical powder could not be recovered or required very extensive cleaning (see Section 7.5).

5.2.2 Clean Agents

By definition clean agents do not leave any residue. Exposed materials might be damaged if chemical incompatibilities exist between the agent and the material. Material compatibility for the neat agent and metals, plastics, and elastomers has been researched extensively by the chemical manufacturers. Most materials tested are industrial/commercial products, not necessarily associated with collection materials.

HCFC Blend B has been subjected to common metals such as aluminum, steel (bare and cadmium plated), copper, magnesium, monel, nickel, stainless steel, titanium, and zinc and has shown to be compatible over a range of conditions [American Pacific Corporation, 2008]. The presence of excessive moisture is an exception and should be avoided except for very short exposures when these metals are in contact with the agent [American Pacific Corporation, 2008]. Of the elastomers tested, only ethylene propylene diene monomer rubber (EPDM), Minnesota Rubber Co. Compound #486BV, and polysulfide were compatible [American Pacific Corporation, 2008]. Elastomers Buna N, Buna S, Buthyl, natural rubber, neoprene, silicone rubber, urethane, Viton® A and Viton® B were shown to be marginally compatible or incompatible [American Pacific Corporation, 2008]. The following plastics were deemed compatible with HCFC Blend B: Acetal (Delrin®), fluorocarbon PTFE (Teflon®), polyamide 6/6 nylon (Zytel®), polyetherketone (Ultrapak®), polyethylene-HD (Alathon®), polyimide (VespeI®), polypropylene (Alathon®, only at ambient temperatures), and polyvinyl chloride [American Pacific Corporation, 2008]. Acrylonitrile butadiene styrene (ABS), acrylic (Lucite®), ethy cellulose, polycarbonate (Lexan®), and polystyrene (Styron®) were all found to be incompatible [American Pacific Corporation, 2008].

HCFC 123, the main component of HCFC Blend B, may be a stronger solvent than other CFC chemicals it was meant to replace, such as CFC-11 [Dupont, 1998].

Stability tests have been performed with HFC-236fa and copper, aluminum, and iron. No visual changes to the condition of the metal or the liquid agent (color) were observed [DuPont, 2007]. Commonly used elastomers, with the exception of Viton® A, have been shown to exhibit negligible swelling, weight gain, or hardness after exposure, and common plastics have been shown to exhibit negligible weight gain or surface change [DuPont, 2007].

HFC-227ea has been found to be a very stable compound and, in the absence of excessive moisture, will not react with common construction materials such as metals, polymers and some elastomers [Kidde Fire Protection, 2003]. Commonly used metals such as steel, cast iron, brass, copper, tin, lead, and “aluminum can” have been shown to be chemically stable with HFC-227ea under normal conditions [DuPont, 2001]. Commonly used elastomers, with the exception Viton® A, have been shown to exhibit negligible swelling, weight gain, or hardness after exposure, and common plastics have been shown to exhibit negligible weight gain or surface change [DuPont, 2001]. Additional testing has shown that urethane shows unacceptable linear swell [DuPont, 2008].

It should be noted that the compatibility studies generally involve the submersion of the material in the liquid agent or exposure of the material to high concentrations of the gaseous agents for prolonged periods of time. This represents the worst case scenario for exposure to the neat chemical agents. Liquid contact in a real world extinguisher scenario should be minimal unless the agent stream is purposely directed at a particular artifact, which could be possible in the case of vandalism. In this case, the exposure duration would be significantly less than in the compatibility testing. In an actual fire event, the artifact that the agent stream is directed towards would be on fire, and the fire damage would most likely be more significant than the damage caused by exposure to the liquid agent. In addition, heat from the fire would help to vaporize the agent, minimizing contact with the liquid.

The impact of the neat clean agents on materials likely to be found in cultural collections has not been well researched. The literature search produced only limited information. The manufacturer of Halotron I (HCFC Blend B) has indicated that the liquid is not compatible if sprayed directly onto movies stored on reel-to-reel type films [Colton, 2009]. It has also been suggested that other halogenated agents (HCFCs, HFCs) would have a similar impact on the films, but this has not been verified. In addition, the manufacturer stated that Halotron I has undergone fabric compatibility testing where a variety of materials and prints were exposed. No incompatibilities were found [Colton, 2009]. No thermal shock characteristics have been identified.

5.2.3 Carbon Dioxide (CO₂)

Thermal shock is postulated to be the primary threat to materials exposed to carbon dioxide. During discharge from a portable fire extinguisher, the agent can reach temperatures of -78°C (-172.4°F) as the liquid flashes from liquid to gas [Jensen, 2006]. Condensation of water vapor can produce “snow,” which can accumulate on materials in contact with the agent stream. In the Norwegian tests, the CO₂ discharge did not affect most of the materials tested. It did cause an untreated leather sample to shrink and left the surface blotched [Jensen, 2006]. It was concluded that temperature sensitive materials may be damaged by CO₂ agent discharge.

Carbonic acid (weakly acidic) forms when carbon dioxide dissolves in water. It is possible to form with the CO₂ interacting with condensed moisture. Significant amounts are not expected in the extinguisher scenario.

5.2.4 Water Mist

The environmental effects analysis in Section 5.1 suggests that many collection materials are susceptible to moisture/water damage. Appendix A provides specific material information. In the Norwegian tests, some limited damage to materials was observed. Wood with tempera was blotchy due to water. Iron corroded; untreated leather was stiff and stuck to its support. Cardboard buckled due to moisture.

5.3 Mechanical Damage

Conservators consider that all artifacts should be treated as extremely fragile, even if they do not appear so [Texas Historical Commission, undated]. Curators may consider the fragility of artifacts in terms of both internal and external vibration. Internal vibrations could result from storage systems. External vibrations might be from subways, trains, and automobiles.

The mechanical damage from potential fire extinguisher discharge was assessed in the Norwegian tests [Jensen, 2006]. The methodology of this assessment appears to be qualitative. Impact tests are not described. In the agent-only test, the extinguishing agent was apparently discharged directly onto the samples laying on the floor. The mechanical impact and power of the ABC powder were deemed to be high. It was judged that it may overturn/break/splinter objects. The spray from CO₂ extinguisher was judged to have sufficient power to cause damage but was less than water or powder. The water mist extinguisher was explicitly not evaluated since the working pressure was incorrect. In terms of overall ratings (1–5, 1 = Poor, could cause damage; 5 = Best, least likely to cause damage), extinguishers were judged for mechanical side-effects as follows: ABC powder – 3; FE-36 and halogen gas – 3; CO₂ – 3; water mist – 4.

6.0 FIRE EFFECTS ON MATERIALS

6.1 General Impact of Fire on Materials

Most artifacts and structures may be damaged when exposed to fire conditions, including paintings, photographs, paper items, metalwork and sculptures, leather, textiles, furs, stone and archeological objects [IGP AS, 2000] [Hajpal, 2002] [Nieuwenhuizen, 2005]. When exposed to high heat and changing humidity levels, paper, wood, and textiles can warp, tear, become brittle, break, split, or grow mold [Texas Historical Commission, undated]. Other materials can experience dilation and contractions due to changes in temperature [Marchetti, 2003]. Photographic emulsions can shrivel, and leather will shrink under high heat conditions [Bishop Museum, 1996].

Direct flame impingement or indirect heating from a fire can cause irreparable damage to artifacts. Examples include melting of paint or plastic, singeing of hair, browning or charring of wood and paper materials, and melting of photographs/film. Many artifacts are combustible; direct flame or heat exposure may cause ignition and self-sustained combustion. Ultimately, the artifact may be a total loss due to fire damage.

In addition to thermal damages, the soot and other particulates deposited by the smoke “can soil, chafe or otherwise blemish artifacts” [Marchetti, 2003]. Removal of these particulates often

requires abrasion, which can damage the artifacts further. In addition, gaseous combustion products, such as nitrogen oxides, can react and form acids which can deteriorate works of art [Texas Historical Commission, undated]. Another damaging effect of soot is that, since a light covering of soot is often undetectable to the naked eye, soot can sit on or in an artifact. In the presence of moisture, this covering of soot can eventually begin to grow mold and bacteria which will rapidly damage the artifact [Bagwell, 2004]. Soot can also severely damage taxidermy, singling fur and hair, shrinking skin, and coating the fur in soot [Nieuwenhuizen, 2005]. Section 6.3.2 describes the affects of an oily, sooty fire on collection materials.

Fire conditions can not only damage artifacts, but also the buildings in which they are stored. This includes heritage buildings such as churches. Archaic building materials such as untreated wood, wood fiberboard, clay tile, and untreated metals can lose structural integrity in less than an hour, often much less. Clay tile and wood fiberboard are especially affected by fire, where fire resistance ratings may be 30 minutes or less [National Institute of Building Sciences, 2000]. In the Windsor Castle fire of 1992, a small fire turned into a disaster when it spread from a small chapel to a roof, which then collapsed into a banquet hall, and continued to spread from there. Most of the materials were likely archaic and had little fire resistance, allowing easy fire spread through the historic building [Stevenson, 1992]. A similar incident occurred in the Moncalieri Castle in Turin, Italy in 2008. A fire in the South East tower of the castle started between the ceiling of the 3rd floor and the floor of the 4th floor. The fire grew and spread quickly, destroying the 3rd and 4th floors of the tower, as well as part of the 2nd floor, where materials had collapsed into. The majority of the tower was constructed of wood [Marmo, Fiorentini, & Piccinini, 2009].

6.2 Fire Byproducts

Fire byproducts created by the thermal decomposition of materials can include smoke and toxic, corrosive, and odorous compounds. The byproducts can produce non-thermal damage in the forms of corrosion, electrical malfunction, discoloration, and odor [Tewarson, Chu, and Hill, 1992]. The non-thermal fire damage of cultural museum collections will depend on the type of fuels involved.

A review of the impact of a common fire byproduct, HCl, was performed. HCl is formed from the combustion of chloride-based materials, such as polyvinyl chloride (PVC). HCl is among the most important toxicant in fires [Wang et al., 2007].

In a study prepared for the U.S. Nuclear Regulatory Commission, component survivability in the presence of increased temperatures, increased humidity, particulate, and corrosive vapors was tested [Jacobus, 1986]. A variety of electrical components were exposed to nuclear power plant control room cabinet fires. The HCl produced by the fires was found to react with particulates in the air. When the particulate containing the chloride ions was left on the component and placed in a high humidity environment, corrosive effects were noted. The corrosive action of the chloride containing particulates in a high humidity exposure caused two electrical counters to fail. All components tested showed signs of non-thermal damage due to HCL corrosion and/or smoke deposition.

Factory Mutual Research Corporation (FMRC) performed a review of literature covering non-thermal fire damage that, among other topics, investigated the impact of HCl [Tewarson, Chu, and Hill, 1992]. The focus of the research was on non-thermal damage as it relates to the telecommunication industry. The literature review revealed the following:

- Exposure of HCl to galvanized zinc or zinc chromate finishes, common in structural components of telecommunication and computer equipment, forms zinc chloride. Zinc chloride is very hygroscopic and attracts moisture from the air even at low humidity. The zinc chloride solution is electrically conductive and can cause electrical shorts if it is deposited onto equipment.
- Large scale testing showed that deposition of corrosive products is most severe in the room of fire origin. For fires with PVC flooring, 50% of the original chloride ions were deposited on the walls. The percent was found to vary with the wall covering.
- Chloride ion deposition is expected to be higher on hygroscopic surfaces such as gypsum wall board.
- A threshold value of 100 ppm HCl was given for non-thermal damage to electronic components (for both no visual or electrical continuity damage).
- Char and black smoke are efficient absorbers of HCl.

6.3 Fire Impact on Collections

The two primary sources of fire exposed material degradation are the Norwegian fire extinguisher tests (Norwegian tests) [IPG AS, 2000; Jensen, 2006] and the detailed report of the Huntington, CA museum fire [Roberts et al., undated]. Data from both of these reports are included in the Appendix A matrix, and briefly summarized here.

6.3.1 Norwegian Extinguisher Tests

In the Norwegian extinguisher tests, representative materials were exposed to a wood pallet fire for fifteen minutes. The exposure temperatures at the fourteen minute mark ranged from 182°C (359.6°F) to over 200°C (392°F). The materials were then examined for damage, with the following general results:

1. Wood – discoloration and bubbling of paint layer occurred; discoloration of tempera by soot;
2. Iron – darkening of metal and dark surface corrosion;
3. Oil paintings – canvas was deformed; darkening of the paint layer and discolorization; layers were found to bubble and/or crack;
4. Leather – severe deformation and scorching;
5. Wool – severe shrinkage; scorching occurred and the wool became crispy;
6. Cotton – scorching and darkening/discolorization occurred;
7. Linen – severe darkening occurred; there was color change; and
8. Cardboard – darkening and deformation of edges occurred; there was no pH change.

6.3.2 Huntington Gallery Fire

An excellent description of smoke damage to a collection is provided in a post-mortem of the October 1985 fire at the Huntington Gallery in Pasadena, California [Roberts et al., undated]. Smoke spread from an elevator shaft fire via the HVAC system to all three floors of the building. Heat damage was limited but smoke damage was extensive. Conservators in each area of expertise reported on the effects of smoke on materials and their conservation/recovery procedures.

A fine, blackened oily film with soot contaminants was deposited throughout the structure. The spread was pervasive; deposits were found in closed desks and the interior of clock movements. Deposits were analyzed by the California Institute of Technology. They were found to be composed of about 50 percent black elemental carbon, mostly in the form of small black specks that would not dissolve in any solvent. The remaining constituents were organic compounds, long chain hydrocarbons similar in structure to lubricating grease. It was noted that the residue was related to wood smoke. The deposits had to be removed before they dried out completely and became insoluble. The following effects were described:

1. Textiles – there was potential deleterious effects resulting from acids which could be produced by the eventual oxidation of the greasy smoke deposits. Samples from contaminated linen drapery materials were extracted with an ethanol-hexane-toluene mixture and with water. Infrared spectra were used to analyze the samples. Water extracts of the fabric were found to be neutral.

Samples of the linen fabric were aged at elevated temperatures in air for several days to accelerate the oxidation of the smoke deposits. Infrared spectra extracts of the aged fabric showed that a portion of the hydrocarbons were converted into compounds containing C=O, C-O, and OH functional groups. These groups are characteristic of organic acids or their precursors, however the water extracts of the aged fabrics failed to reveal the presence of water-soluble acids. Although the production rate of organic acids at room temperature is expected to be low, it was recommended that cleaning of the contaminated textiles not be postponed any longer than necessary.

The composition of a poultice used to clean large rugs was analyzed for potential harmful effects using infrared, x-ray fluorescence, x-ray diffraction, and polarized light microscopical techniques. Freon 113 was used as a solvent in the poultice because it readily evaporated.

Water as a solvent was generally ruled out since the soot was hydrophobic, and color bleeding might occur.

Window draperies were processed with a petroleum distillate solvent (petroleum naphtha).

2. Marble sculpture – staining occurred by dripping water due to condensation during the fire (and presumably the water handline suppression activities). Sculptures were covered in soot. The recovery effort focused on removing the soot without creating indelible stains by driving the greasy carbon into the stone. Synthetic detergent was

used for cleaning; obstinate stains were removed using methylene-chloride based paint stripper. Unyielding stains were cleaned with a solvent mixture of 3% sodium bicarbonate and 2% ammonium bicarbonate.

3. Metals (bronze sculptures and silver pieces) – ionized water with ethanol and a mild, basic detergent were used to clean bronze sculptures after soot was gently removed using compressed air and soft brushes. Straight ethanol was not used on Renaissance bronzes since it might cause blanching. Cleaned silver was rinsed with ethanol to remove water, and then dried. Inadvertent high humidity conditions resulted in the long term (six-month) alteration of a bronze statue having an opaque black patina. Unprotected areas became sticky and viscous, potentially a result of protection/encasement techniques. Copper salts were identified as the attacking material.
4. Furniture – furniture was cleaned with mineral spirits (paint thinner) on a damp swab, followed by a dry wipe. Some blooming or whitening had occurred. Picture frames were checked for oil or water gilding (covering/cracking).
5. Glass and ceramics – these materials were cleaned with mild liquid detergent and rinsed with water.
6. Books – existing dust on books made clean up of the soot easier, using vacuums.
7. Oil paintings – during cleaning, some blooming of the old natural resin varnishes occurred, but this could generally be cleaned off with solvent. Wax surface coatings over varnish and varnishes having wax additives appeared to have softened and absorbed more smoke/soot.
8. Building structure – the plaster ceiling in the ground floor hallway was severely damaged by heat and smoke. Some decorative moldings fell.

7.0 COMBINED FIRE AND EXTINGUISHING EFFECTS

There are two primary sources of estimating combined effects of fire and extinguishing agents. One is by assessing how, as the agent interacts with the fire, thermal decomposition products (TDPs) can be formed. The types of TDPs vary based on the agent. The second source is from actual data from the Norwegian (COWI) tests. Assessments were made as a function of the extinguishing agent.

7.1 ABC Dry Chemical

The TDPs of the ABC agent can include carbon monoxide (CO), carbon dioxide (CO₂), and sulfur dioxide (SO₂) [Amerex, 2008; Buckeye, 2007]. Additionally, oxides of phosphorous and ammonia have been reported [Amerex, 2008; Buckeye, 2007; Pyro-Chem, 2007].

On Class A fires, the particles of the ABC powder fuse and swell up to form a barrier or coating on the surface of the burning material [Chemguard, 2005]. This coating can be difficult to remove.

In the Norwegian tests, the combined effects were similar to those with ABC alone [Jensen, 2006]. Corrosion on the iron was found after one month. It may be especially hard to remove the powder coating on metals. Depending on the sensitivity of the material, it is reasonable to assume that fragile materials could be damaged during the cleanup process.

7.2 Clean Agents

Decomposition products of both HFCs and HCFCs include hydrogen fluoride (HF) and carbonyl fluoride (COF₂). Small amounts of hydrogen chloride (HCl) will also be generated by HCFCs. Of the possible TDPs, HF is the decomposition product of greatest concern [Hanauska, Forssell, and DiNenno, 1993]. The formation of HF has been shown to be directly related to the fire size, compartment volume, and fire extinguishment time [Peatross, 1998]. Delivered agent concentration and discharge time are factors that influence the extinguishment time. For streaming agents, both of these factors are influenced by the application technique of the operator. Additional variables that affect HF formation include the fuel type and arrangement, vaporization and mixing of the agent, and presence of hot surfaces or deep seated fires [Hanauska, Forssell, and DiNenno, 1993].

The amount of HF produced has been extensively investigated. However, most research has involved using the clean agents in a total flooding capacity. Two reports specifically related to the application of a streaming agent and the resulting HF production.

The first test series conducted by the New Mexico Engineering Research Institute (NMERI) tested HFC-227ea (FM-200) as a streaming agent and measured the HF production [Moore, 2000]. A 0.21 m² (2.25 ft²) pan fire containing Jet-A fuel was ignited within a 18.3 m³ (645 ft³) test enclosure. The fire was ignited 60 seconds before the fire was attacked by a firefighter. In tests where the fire was extinguished, HF concentrations peaked between 1,000 and 4,000 ppm with the concentration leveling off around 1,200 ppm after approximately 50 seconds.

The second test series was conducted by the National Research Council Canada (NRC) [Su and Kim, 2002]. A variety of hand held extinguishers were tested including HFC-227ea (FM-200), HCFC Blend B (Halotron I), and HFC-236fa (FE-36) against heptane pan fires. Three enclosure sizes (45 m³, 120 m³, and 21,000 m³ (1,589 ft³, 4,237 ft³, and 741,608 ft³)) were tested. The construction detail of the small and medium enclosures is not provided. The large area tests were conducted in the NRC burn hall. The small enclosure was used to test a 300 kW and 550 kW fire. The medium enclosure was used to test a 300 kW and 900 kW, and the large test enclosure was used to test a 900 kW and 2,000 kW fire. The size of the extinguisher was adjusted based on the fire size. If the fire was extinguished, the extinguisher was immediately closed to stop the agent discharge.

In all tests, gas samples were measured at the operating breathing zone located approximately 2.4–2.9 m (7.9–9.5 ft) from the pan and 1.5 m (4.9 ft) above the ground. Additional gas samples were measured at various other locations depending on the enclosure being used. Gas samples were analyzed for various decomposition products including HF, COF₂ and HCl. As expected, HF was the major byproduct for the three streaming agents of interest for use in cultural media collections (HFC-227ea, HCFC Blend B and HFC-236fa). The amount of HF (and HCl for HCFC Blend B) varied with the fire size-to-enclosure size ratio, the amount of agent discharged,

and fire extinguishment (and the associated extinguishment time). The concentrations are presented in Tables 3–5 for the small and medium enclosure tests. For the large enclosure, HF (and HCl) levels were below the sensitivity of the instrumentation.

Table 3. Decomposition Products of HFC-227ea

| Enclosure | Fire Size (kW) | HF Concentration (ppm) | HCl Concentration (ppm) |
|---|----------------|--------------------------|-------------------------|
| 45 m ³ (1,589 ft ³) | 300 | 5,000-7,000 ² | N/A |
| 120 m ³ (4,237 ft ³) | 300 | 2,500-3,000 ¹ | N/A |
| | 900 | 6,000-6,500 ¹ | N/A |

1 – Fires not extinguished

2 – Lower value for fire not extinguished, higher value for fire extinguished using two extinguishers consecutively

Table 4. Decomposition Products of HCFC Blend B

| Enclosure | Fire Size (kW) | HF Concentration (ppm) | HCl Concentration (ppm) |
|---|----------------|--------------------------|-------------------------|
| 45 m ³ (1,589 ft ³) | 300 | 3,000-3,500 ¹ | 1,700-2,000 |
| | 550 | 4,500-6,000 | 3,200-4,200 |
| 120 m ³ (4,237 ft ³) | 300 | 300-1,000 ² | 500-1,000 |
| | 900 | 2,000-3,000 | 2,000-2,500 |

1 – Fires not extinguished

2 – Lower HF value for extinguished fire, higher for fire not extinguished

Table 5. Decomposition Products of HFC-236fa

| Enclosure | Fire Size (kW) | HF Concentration (ppm) | HCl Concentration (ppm) |
|---|----------------|--------------------------|-------------------------|
| 45 m ³ (1,589 ft ³) | 550 | 8,000-9,000 | N/A |
| 120 m ³ (4,237 ft ³) | 900 | 6,000-6,500 ¹ | N/A |

1 – Fires not extinguished

As clean agents are primarily used to protect essential electronics in applications such as data process centers and telecommunications facilities, the main focus of research has revolved around the impact of HF on electrical components. Several test series have been performed.

In testing conducted by Hughes Associates, HFC-227ea (FM-200) was used as a total flooding agent to extinguish test fires representative of those expected in a computer environment [Hughes Associates, 1995]. Four fuels sources were tested including wastebasket with paper, printed circuit boards, electrical cables, and magnetic tapes. The fires were contained in a 72.5 m³ (2,562 ft³) enclosure that was protected with a HFC-227ea design concentration of 7.0%. The system actuation time and discharge time were varied. Relialogic ISA I/O cards were installed in the test enclosure. Peak concentrations ranged from 30 ppm to 1,700 ppm, and 10 minute average concentrations ranged from 10 ppm to 1,000 ppm. No card failures were recorded when checked 30 days after exposure.

Testing conducted by the NRC studied the corrosive effects of HF on electronics [Kim, Crampton, and Kanabus-Kaminska, 2003]. The testing exposed various HF concentrations to three different types of electronics. Two were custom made corrosion detector boards, and the third was a commercially available PCI video card. The electronics were placed in 1 m³ (35.3 ft³) stainless steel test box, and a pre-determined amount of HF was injected into the box. Based on previous fire testing to determine HF levels in electronics facilities, the concentrations ranged from 200 ppm to 5,000 ppm. The humidity level in the box was varied. After exposure, the electronic components were examined for short term and long term corrosion.

The testing showed that the components were clearly affected by the exposure to HF, especially at high humidity levels. The HF was found to react with moisture in the box and condense as acidic liquid drops, which had the ability to produce surface corrosion on any exposed surfaces. The custom electronic boards showed no visual signs of corrosion when exposed to HF at 2,500 ppm for one hour in very dry conditions but minor surface corrosion when exposed to 1,000 ppm for one hour in humid conditions. Above 5,000 ppm, heavy corrosion was noted on the specimen surface and the electronic circuit under the protection layer of the electronic board was damaged. The functionality of the video card was affected when exposed to 500 ppm and above for one hour.

After the initial inspection, the boards were cleaned and stored for long term evaluation. Six months after the exposure, the test specimens showed a definite change in surface corrosion and functionality. One video card that had partial functionality after the initial exposure lost all functionality.

Studies covering the impact of HF on items expected to be found in a cultural resource collections were not located. One source referenced a 1998 standard from the Loss Prevention Council, "Gaseous Fire Extinguishing Systems using Halocarbon Agents: Guidance for Insurers, LPR 10" [Woods, undated]. The author stated that the LPC standard included language regarding the use of halocarbons in cultural resource collections. Specially, the standard outlined that halocarbon TDPs are damaging to organic materials and that the Loss Prevention Council viewed halocarbon agent systems as not ideal for use in "records stores" and other "cultural heritage" sites [Woods, undated]. The LPC standard could not be located for verification, and the basis for this recommendation is unknown.

Forssell et al., in their evaluation of the IMO gaseous agents test protocol, correlated the thermal decomposition product formation for a variety of gaseous agents to the fire size to room volume ratio [Forssell et al., 2001]. This correlation was developed utilizing data from the IMO tests conducted by the USCG and from other literature sources. This correlation is given in Figure 1. Utilizing the two smallest design fires from Table 2 with peak fire sizes of 200 kW and 500 kW respectively in a 100 m³ gallery, resulting concentrations of approximately 1100 ppm and 2750 ppm HF would be expected. Note: The NRC data presented in Tables 3 through 5 would be well represented by the correlation of Figure 1 with the "unextinguished-fire" test data being above the correlated line and the extinguished fire test data being on or below the correlated line.

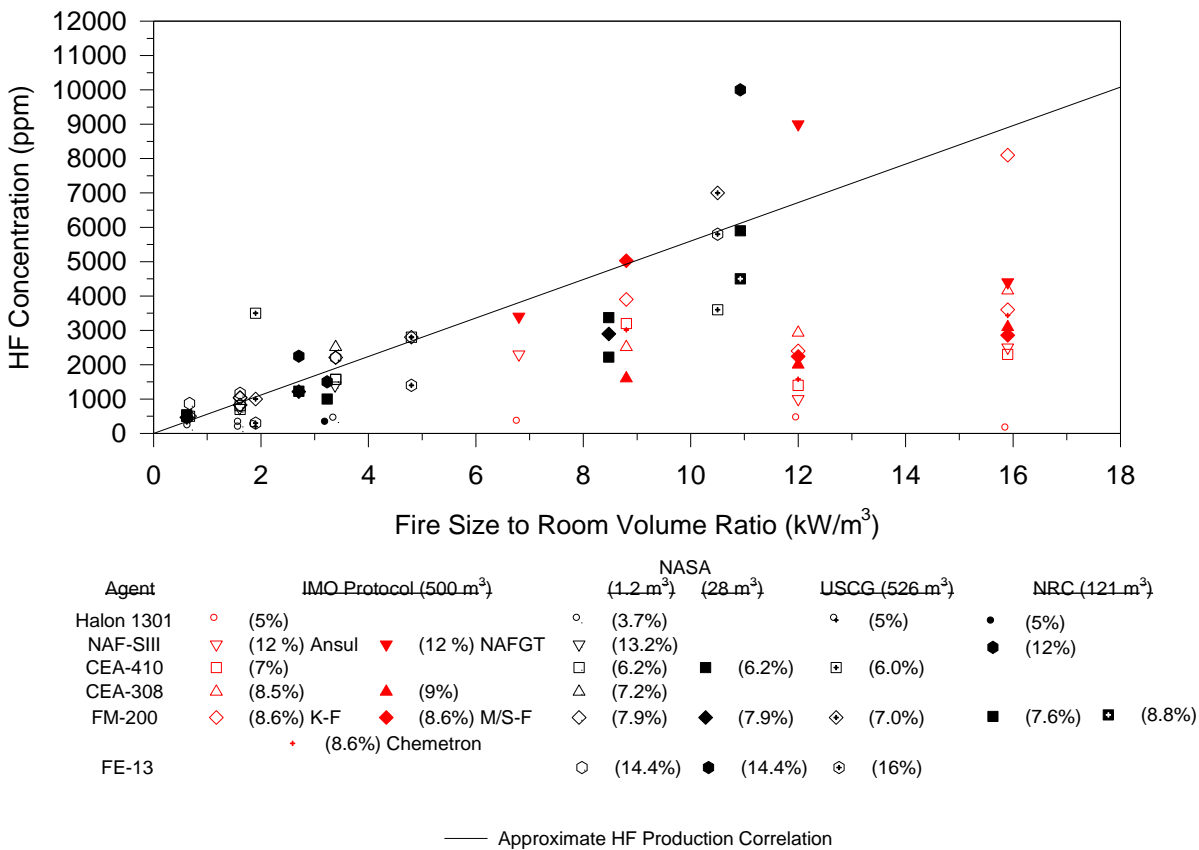

Figure 1. Resultant average (5 minute) hydrogen fluoride concentration as a function of the fire size to room volume ratio (NRC values are 3 minute averages) [Forssell et al., 2001]

Dumayas [1993] exposed I/O cards to the environments results from the extinguishment of n-heptane pan fires with CEA-410 (PFC-3110), FM-200 (HFC-227ea) and FE-13 (HFC-23). The exposure to the cards was up to 2126 ppm HF on average over a 6 minute time period prior to venting the enclosure. The cards were tested for function immediately after exposure and 20 to 60 days after exposure with no observed loss of function. Some corrosion of the contacts at the bottom of the cards was noted.

Pedley exposed printed circuit boards to HF and HBr gaseous mixtures at 50% humidity for 48 hours and operating central processor units for 24 hours in order to simulate the resultant environments from extinguishment with halon 1301 [Pedley, 1985]. The 50% humidity level was not varied during the tests. The exposed concentration levels were 500 ppm HF and 200 ppm HBr; 5,000 ppm HF and 2,000 ppm HBr; and 50,000 ppm HF and 20,000 ppm HBr. Only slight damage to the circuit boards and the operating CPUs were observed after exposure to the lowest concentration levels. During exposure to the medium level, three of the four CPUs shutdown with the first shutdown 3.6 hours into the exposure. The fourth CPU shut down 56 hours after the end of the exposure. Two of the four CPUs were able to be restarted four days after exposure. There was slight corrosion observed on all of the printed circuit boards and the appearance of the coating had dulled. At the highest level, there was significant damage to all of the circuit boards and the CPUs with no recovery of function after the end of the exposure.

The deposition of the HF and subsequent damage is a function of the exposure dosage (concentration multiplied by duration of exposure). Ignoring the presence of the HBr gas in Pedley's exposure tests, the lowest exposure dosage was 1,440,000 ppm minutes for the printed circuit boards and 720,000 ppm minutes for the operating CPUs. The dosage from the design fires in the 100 m³ gallery after purging with fresh air 30 minutes after extinguishment would be 33,000 ppm minutes and 82,500 ppm minutes. This dosage is 2.3% and 5.7% of the dosage to which the printed circuit boards were exposed to by Pedley at the lowest level. This dosage, however, exceeds the 12,600 ppm minutes of the Dumayas exposed cards.

No information was identified on the effects of HF specifically on collection materials.

Most of these studies utilized clean agents employed in a total flooding application, or employed as a portable extinguisher in a small enclosure mimicking a total flooding application. This does not capture the geometric aspects encountered with portable extinguishers where a uniform mixture is not achieved or is not achieved until sometime after the discharge has been completed. The concentration of the agent and the thermal decomposition products would be highest within the spray pattern of the extinguisher during the discharge and much lower outside of the pattern. After the discharge of the agent has ended, both the agent and decomposition products would dissipate to levels much lower than what was within the pattern, similar or higher than that outside of the pattern. These differences could cause the exposures predicted from total flooding measurements to be overstated for items outside of the extinguisher spray pattern, but could also understate the exposure for items within the pattern, at least for the time period over which the extinguisher is discharging.

7.3 Carbon Dioxide (CO₂)

Carbon dioxide is thermally inert and does not produce any TDPs [DiNenno et al., 1993]. In the Norwegian tests, materials were generally covered with a fine powder. The origin of this powder was unexplained. It may have been soot dislodged when the extinguisher was discharged. Iron showed tarnish. Oil paintings showed cracks, shrinkage, and bubbling of the paint layer potentially due to large variations in temperature. Wool showed changes in color.

7.4 Water Mist

In the Norwegian tests, there was discoloration and blotches observed on many materials, including wood, iron, oil paintings, cotton, and linen. There was corrosion on untreated iron.

7.5 Summary

The results of the studies/data reviewed indicate potential effects of agents, but are incomplete for the cultural collection scenarios. The data are difficult to compare directly to this application, suggesting the need for testing.

Of all the agents tested in the Norwegian tests, water mist and ABC powder were considered to cause the least amount of damage on the materials. Fire suppression agents were applied on samples after they were cooled to 50°C (122°F). There was a caveat to the conclusions, which noted that, when powder comes in contact with heat, other substances will be formed, and these will create a glaze on materials that is hard to remove.

The results from the Norwegian testing are somewhat contradicted by one example in the loss history. The persistence of dry powder was emphasized in loss experience at the Smithsonian Institution. In one fire involving a collection object on display, an ABC dry powder extinguisher was used to successfully extinguish the fire. The collection object involved was declared a total loss, reportedly because conservators could not begin to remove all of the powder. In another Smithsonian gallery fire, a fire was extinguished with dry powder but the gallery had to be closed for several weeks due to extensive powder cleanup efforts [IGP AS, 2000]. Perhaps this was the rationale for incorporating the cautionary statement in the Norwegian report with ABC results.

Halon 1211 alternative gaseous agents were mentioned in the Norwegian report, but not tested or analyzed in detail. They were noted as having practically no chemical effects.

8.0 ESTIMATING DISPERSION AND CONCENTRATION OF CONTAMINANTS

In a fire event involving discharge of an extinguishing agent, both the smoke created by the fire and the extinguishing agent being discharged can have adverse effects on cultural resource materials, both in the near-field (area impacted by the fire) and far-field (areas remote from the fire). Smoke, extinguishing agent, or a combination of the two can spread throughout a museum via multiple mechanisms and extensively expose museum collections. It is desirable to utilize analytical tools for estimating the dispersion and concentration of agents both for the purposes of evaluating the consequences of a postulated event as well as the means for reducing the impact of that event.

8.1 Factors Influencing Agent Spread

The extent of spread of contaminant(s) through a museum, whether they consist of smoke, extinguishing agent, thermal decomposition products, or some combination, is dependent on a number of factors. The nature of the fire/discharge event will determine the type and amount of contaminant(s). The specific geometry of both the room of fire origin and adjacent spaces, as well as the connections between these spaces, will impact the extent of spread of these contaminants. The design of the building heating, ventilation, and air-conditioning systems (HVAC) serving the building can potentially result in contaminant spread to spaces not directly connected to the room of fire origin.

8.1.1 Fire/Discharge Event

The nature of the fire/discharge event is the first factor that must be evaluated in order to estimate the dispersion and concentration of contaminants. The type of fire present at the time of agent discharge and the duration and effectiveness of the extinguishing effort essentially establishes the source term(s) (model inputs) for the estimation of contaminant spread.

The intent of providing portable fire extinguishers is to enable museum staff and/or visitors to extinguish the fire in its incipient stage, while the fire is still small. When this effort is successful, the threat of damage from fire byproducts (heat, smoke) is greatly diminished and what remains is essentially a neat agent, consisting of the agent discharged alone without abnormal environmental or fire effects. A neat agent may also be present in the event of an accidental extinguisher discharge. In an event involving primarily neat agent, the agent

(dispersed as a concentration in air in the room of fire origin over a discharge duration) is the sole contaminant. The spread of agent both within the room of origin and to adjacent spaces is governed primarily by the momentum of the extinguisher discharge and the spread of agent mechanically via the HVAC systems.

When a fire is large at the time of agent discharge, or continues to grow due to the type of combustibles involved or due to inefficient application of the extinguishing agent onto the fire, a significant amount of thermal decomposition products (TDPs) can be created by the interaction of the agent with the fire. TDPs can then represent an additional contaminant that could damage cultural resources both in the room of fire origin and remote spaces. In addition to TDP creation, prolonged exposure of the agent to the fire can cause a state change in the agent, such as agglomeration of dry chemical particles that are not decomposed, which could then impact the properties of the agent as it spreads through the building.

If a larger fire is present, buoyancy driven flow may also be a significant driver of contaminant spread, for smoke (soot), decomposition products, and extinguishing agent entrained along with the buoyant plume from the fire.

8.1.2 Room/Building Geometry

The specific geometry of both the room of fire origin and adjacent spaces, as well as the connections between these spaces, directly impacts the spread of contaminant beyond the room of fire origin. Museums tend to consist of collections of various size enclosures with large open doorway, hallways, and other connections to facilitate flow of visitors between galleries. Closed doors and other barriers to resist contaminant spread are typically only present between galleries and support spaces or where rated fire/smoke barriers are present. Where these barriers are present, the doors are normally held open with magnetic devices and will release during a fire event via a general alarm or local smoke detection. The doors may not close for an event of a small fire extinguished by the agent discharge; thus, adverse contaminant spread may still occur. In general, the degree of openness between spaces in a museum is a significant factor impacting contaminant spread in the event of a fire or extinguisher discharge.

8.1.3 HVAC Systems

The design of the building heating, ventilation, and air-conditioning systems (HVAC) serving the building can potentially result in contaminant spread to spaces not directly connected to the room of fire origin. Museums tend to be served by closed-loop mechanical ventilation systems that have a high degree of re-circulation, due to the need to condition the air to maintain tight control on temperature and humidity within the museum spaces to protect the collections. Large museums will have multiple HVAC zones, and spaces within a given HVAC zone are connected via the system. There may be no cross-connection to other systems; alternately, open spaces may be served by multiple HVAC systems.

Museum HVAC systems generally utilize ducted supply and either ducted or plenum return systems. Plenum return may be accomplished via an air plenum above a drop-ceiling or lay-light ceiling. Air is drawn back to the supply air serving the zone, re-conditioned and then re-circulated back to the spaces served by that zone. The HVAC system generally includes some

sort of filtration in the closed loop, with the effectiveness of the filtration being dependent on the MERV rating of the filter (range: 1–16). Filters can range from course screens to high efficiency particulate air (HEPA) filters that by definition remove at least 99.97% of airborne particles 0.3 micrometers (μm) in diameter. While filters would be ineffective in mitigating the spread of gaseous contaminants (agent or decomposition products), the right filter could be very effective in mitigating the spread of soot or dry chemical agent to remote spaces via the HVAC system.

In many situations, smoke detectors installed in HVAC systems are designed to automatically stop fan systems. Where there is an engineered smoke control system, specific fan/damper actuation or shutdown may occur on activation of an installed detection system.

8.2 Methods of Analysis

In order to evaluate the impact of agent spread throughout a museum, analytical tools must have the capability of properly defining the source terms in the room of fire origin, the modes of transport for material either in a gaseous or particulate form, and the resulting impact of the agent once it reaches a remote space. Of the various methods of analysis evaluated for this literature search, no single ideal tool was identified which is capable of evaluating all aspects of this complex problem. However, tools are available that are capable of adequately evaluating individual portions of this problem.

With respect to modeling transport of contaminant in buildings, the available methods generally fall within two broad categories [Axley, 2007]. Macroscopic methods predict the bulk characteristics of this transport and are based on idealizing buildings as collections of control volumes within which the conservation equations (mass, momentum, or energy transport) are evaluated. Microscopic methods can evaluate spatial distributions within individual spaces as a function of the partial differential conservation equations applied to select portions (cells) of a system. Building airflow models are considered macroscopic evaluation tools, while computational fluid dynamics (CFD) models are considered microscopic evaluation tools.

8.2.1 Building Airflow Models

Building airflow models are a tool for estimating the extent of contaminant within buildings. These models are commonly used for evaluating indoor air quality (IAQ) issues, CBRN events, and even smoke spread due to fire. Many different building airflow models were identified in the literature, but the models with the most versatility and widespread use are COMIS [Feustel and Rayner-Hooson, 1990] and CONTAM [Walton and Dols, 2005]. Both models have undergone validation studies and have been shown to have reasonable agreement with experimental data with respect to both air flow and contaminant spread predictions [Haghighat and Cherif Megri, 1996].

CONTAMW [Dols, Walton, and Denton, 2000] is the latest, windows-based version in the CONTAM family of public domain building airflow and contaminant dispersal models developed by the National Institute of Standards and Technology (NIST). It is the most widely used building airflow and contaminant dispersal model in the U.S. It is readily available as a public domain software package and the model interface is easy to use in terms of defining the building geometry and processing model results.

CONTAM is capable of modeling wind effects on the building as well as stack effects caused by differences between a building's interior temperature and the exterior temperature. Simplified HVAC system models as well as a detailed ductwork sub-model are available to evaluate the effect of HVAC systems on contaminant spread. The sub-model is capable of modeling re-circulating as well as 100% outside air ventilation systems, and includes the means for accounting for duct leakage and pressure losses as well as filters. The position of doors and windows as well as HVAC system capacities can be varied over time using the model's schedule feature. Contaminant source or sink icons may be placed in any zone. These icons represent any feature that produces, removes, or absorbs a contaminant. Spread of a contaminant over time to other rooms/zones of the building is tracked by the model as a function of time.

In order to use CONTAM to model contaminant spread within a building, a number of limitations must be taken into account. First, each zone is treated as a well-mixed volume. Temperature or contaminant stratification within a zone, as would be the case given a hot smoke layer, is not accounted for. Also, while individual temperatures can be assigned to each zone, a temperature cannot be assigned to individual contaminants. Thus, the buoyancy-induced flow exhibited by smoke, particularly in those zones closest to the fire, is not accounted for. Because buoyancy-induced flows have the potential to play an important role in smoke spread, the CONTAM model is best suited for those applications where buoyancy effects are minimized. For instance, sprinklered buildings are better suited to use of the CONTAM model than are non-sprinklered buildings. Upon sprinkler activation in the room/zone of fire origin, the sprinkler water spray cools the hot smoke and stirs the smoke layer, driving some smoke down to the floor level. The mixing that occurs better approximates CONTAM's assumption of a well-mixed volume. The reduced smoke temperature reduces the extent of the buoyancy-induced flow associated with the smoke.

Buildings that are highly compartmented are also better suited to using CONTAM, particularly those that are broken up into multiple compartments using smoke barriers. Confining a fire to a specific volume will aid in the development of a well-mixed volume. Smoke spread across the smoke barriers will be predominately governed by building forces such as wind, stack effect, and HVAC systems. Smoke spread from the confined compartment due to buoyancy can also be better approximated by defining an elevated smoke temperature in the room/zone of fire origin and using this temperature as the mechanism for buoyant spread across the compartment boundaries in the model. Once smoke has migrated from the room of fire origin it is either cool enough where the buoyant forces are minimized or additional sprinklers may activate to further aid in the creation of a well-mixed volume in the adjacent space.

In buildings that are not sprinklered or where individual zones are connected by large openings, such as open corridors, buoyancy may play a more predominant role in smoke spread. When used for modeling smoke movement where buoyant flow is expected to be a factor in the spread of smoke, CONTAM is most appropriately used to examine "far-field" conditions. Far-field conditions exist in those areas of a building further downstream from a zone containing a fire, where cold-smoke conditions prevail. Far-field smoke conditions better approximate the well-mixed zone volume assumed in the model. "Near-field" conditions exist in those areas of the building close to the fire, in which hot-smoke conditions result in buoyancy induced smoke flow. In order for smoke movement behavior to be adequately modeled using CONTAM, the near-field behavior of the smoke must be accounted for using other appropriate tools. Methods

are available for accounting for buoyant flow within the model [Ferreira, 1996] but these methods are approximations and require input from separate CFD or mathematical models.

Use of CONTAM or another building airflow model to estimate the dispersion and concentration of contaminants (including extinguishing agent) in buildings during the discharge of agent from a hand-held extinguisher is somewhat complicated. The well-mixed volume approximation may introduce significant error. Wang and Chen [2008] found that the well-mixed assumption could cause significant inaccuracies in the calculation of contaminant distribution, particularly for large spaces with contaminants dispersed in a sub-region of that space. Attempts have been made to use CONTAM as a quasi-CFD model, breaking up large rooms into smaller volumes with open boundaries, but the use of the model in this way has not been validated.

The ductwork models in CONTAM do not have the specific ability to account for deposition of contaminant in the ductwork, and will thus over predict the amount of contaminant reaching a remote space via the HVAC system. If the rate of ductwork deposition can be accounted for using a mathematical model, CONTAM can account for the reduction of contaminant spread to remote spaces by placing a filter in the ductwork having an equivalent removal rate.

The well-mixed approximation used in CONTAM can also affect the evaluation of contaminant impact on cultural resources in remote spaces. While CONTAM does contain a sink model to account for deposition rates within a zone [Walton and Dols, 2005], this model is not able to discriminate between individual surfaces of the space with respect to deposition and is not able to consider relative distances between targets and sources of contaminant such as open doorways to adjacent compartments or HVAC supply inlets.

8.2.2 CFD Models

CFD models provide advantages over building airflow models in that they are capable of resolving spatial phenomenon in the near-field that may be important in understanding the dispersion of contaminant to the far-field.

A number of CFD models are available for use in evaluating fire phenomenon, with a partial list including Fire Dynamics Simulator (FDS), FLUENT, STAR-CD, SMARTFIRE, and Jasmine. For the purposes of this literature review, the discussion will be limited to two models, FDS and FLUENT, with the former being a free public-domain software package designed specifically to model fire phenomenon and the latter being an expensive commercially available software package that has been used to model a wide range of flow regimes and phenomena. FDS is used extensively in the fire protection engineering community to model fires, with FLUENT having somewhat limited use for this application. FLUENT is probably the most widely used multipurpose CFD code for a range of engineering applications.

The FDS program [McGrattan and Forney, 2008] has been under development at the National Institute of Standards and Technology (NIST) Building Fire Research Laboratory (BFRL) for over a decade and utilizes large eddy simulation. The model is specifically designed with fire scenarios in mind and continues to be improved and to have its results verified. Various versions of the model have been applied to a number of outdoor and indoor fire scenarios. The

current version of the model is intended to handle isolated and spreading fires in human habitable spaces in the presence of obstacles such as furniture, overhead ceiling obstructions, and other structural members. The model can handle both passive and forced vents (i.e., smoke exhaust). Validation studies for FDS are described in the FDS manual [McGrattan and Forney, 2008].

FLUENT (<http://www.fluent.com/>) is a flexible and powerful modeling tool that allows selection of many different turbulence models including large eddy simulation. The model can account for similar geometric and ventilation parameters with respect to FDS for the purposes of modeling a fire event. In at least one identified instance [Chang et al., 2003], reasonable agreement between FDS and FLUENT, for atrium geometries, was reported in the literature.

Both FDS and FLUENT have some limitations with respect to fully modeling the interaction of extinguishing agent with a fire. Both models report the capability for modeling the interaction of water sprays (in both sprinkler droplet and mist form with the fire), and FDS has undergone limited validation for this application [McGrattan et al., 2008]. Neither model contains specific combustion models for gaseous agents, although some experimental work has been done in this area [Gmurczyk et. al., 1994; Tsuruda and Makarov, 2000]. Neither model currently contains the ability for estimating TDP creation or particulate settling on surfaces.

The literature search was unable to identify any work that has been done to use CFD to model the suppression of a fire using a dry chemical extinguishing agent. This type of agent interferes with free radical fire chemistry as one of its extinguishing mechanisms, which is not capable of being modeled using current CFD codes. FLUENT has been used to model powder coating, spray drying, and the use of dry powder inhalers, although the extent to which these types of simulations have been validated versus experimental data is unknown. However, the capability of FLUENT to model powder sprays may have the potential for use in evaluating the spatial concentration of neat agent in the room where the agent is sprayed and in adjacent enclosures.

8.2.3 Mathematical Models

Mathematical models in the form of derived equations and engineering correlations derived from test data are available to describe several of the key factors that impact the dispersion of contaminants. For example, engineering correlations have been developed to characterize the quantity of TDP created from the application of gaseous halocarbon agents, as a function of fire size and agent concentration. While much of this work has been done to characterize TDP creation in total flooding applications [Peatross, 1998], as discussed in Section 7.2, some of this work has involved local application via hand-held extinguishers [Moore, 2000; Su and Kim, 2002].

Nazaroff has done significant work in the area of modeling particle deposition, both in ventilation ducts [Sippola and Nazaroff, 2002a, 2002b] and on compartment surfaces [Nazaroff, 1989; Nazaroff et al., 1990]. Specifically, his work on characterizing deposition on compartment surfaces focused on particle deposition in museums. This work may be particularly useful in developing mathematical models to characterize the deposition of dry chemical agent on museum surfaces.

Nazaroff's doctoral dissertation [Nazaroff, 1989] and a subsequent paper published in the *Journal of Aerosol Science and Technology* [Nazaroff et al., 1990] summarize work that was done to characterize the deposition of fine soiling particles onto surfaces. Experimental measurements from which the mathematical models were derived were performed at five Southern California museums, including the Getty Museum. This work enabled particle deposition rates to be characterized in terms of a mean particle deposition velocity. Temperature differentials within the room (particles/air/surface) were also shown to have an impact on deposition rates. The work concluded that the deliberate control of temperature and air flow conditions within a room (reducing normal HVAC system velocities for example), in addition to other methods such as particle filtration in HVAC system ductwork, have potential for use as tools to reduce soiling rates in museums. While the fine soiling particles had relatively small diameters of (0.05–2 μm) versus that typically found for dry chemical extinguishing agents (25–95 μm), the mathematical model has merit for the latter application.

8.2.4 Hybrid Approaches

It is possible to use a combination of the techniques used in building airflow models, CFD models, and mathematical models to develop hybrid approaches. This may allow a better characterization of the transport and dispersion of contaminants.

The simplest method for doing this is to utilize a mathematical model to define the inputs to a particular aspect of a building airflow or CFD model. For example, in CONTAM it may be possible to use the mathematical models developed by Nazaroff to better characterize particle deposition in CONTAM, using a filter model in HVAC system ductwork or a sink model in a zone remote from the zone of origin. Engineering correlations may also be able to be used to define TDP concentrations as inputs into building airflow or CFD models.

Research is currently being conducted on coupling multizone building airflow models and CFD models to enable spatial characterization of particular zones in a model [Khalifa et al., 2007; Wang and Chen, 2008]. NIST has an ongoing research effort enabling the use of a simple CFD analysis in zones defined within CONTAM. It may be possible using such an approach to build a museum model that relies on the simple uniform concentration approximation for all zones except for the zone of fire origin and a specific target zone housing cultural resource materials of particular concern.

8.3 Summary

It is clear that no single analytical tool exists that is capable of modeling the complex phenomenon involved in estimating the dispersion and concentration of contaminants due to the use of an extinguisher to combat a fire in a museum building. However, depending on the level of fidelity required in the analysis, tools do exist that could both be used to estimate the extent of damage to cultural resource materials and the reduction in damage that may result from the implementation of means intended to mitigate this damage.

Provided that threshold evaluation criteria (e.g., maximum agent/soot/TDP concentration, dry chemical agent deposition parameters) can be established by experimental or other means, it may

be possible to use a simple building air flow model or hybrid approach combining a building airflow model with targeted CFD or mathematical models to provide this estimation.

Since the focus is on hand held portable extinguishers and associated local effects, it was decided not to further pursue this modeling as part of this research effort.

9.0 TEST METHODS FOR QUANTIFYING THE IMPACT OF AGENTS ON MATERIALS

9.1 Enclosure Test Scenarios

9.1.1 Norwegian Extinguisher Tests

As noted in Section 5, the RNDCH conducted exposure tests with representative museum materials subjected to fire/smoke exposures and extinguisher agents. Three scenarios were evaluated: fire/smoke exposure; fire/smoke exposure with suppression using the portable extinguishing equipment; and, extinguisher agent discharge only onto the samples. The test set up/data are included in the two referenced reports [IPG AS, 2000; Jensen, 2006], but some of the details are incomplete. The following provides an overview of the test methodology.

Tests were conducted in a chamber measuring 3.8 m x 3.0 m x 3.75 m (12.5 ft x 9.8 ft x 12.3 ft) high (Figure 2). The enclosure material, described as a tank, is unreported. It had a single opening measuring 2.2 m (7.2 ft) wide x 2.0 m (6.6 ft) high with two doors. There was mechanical ventilation, which was secured after a 2 min 40 sec preburn of the fuel package, presumably to supply air for good fire growth and circulation of fire gases in the space. Mechanical ventilation details are unreported.

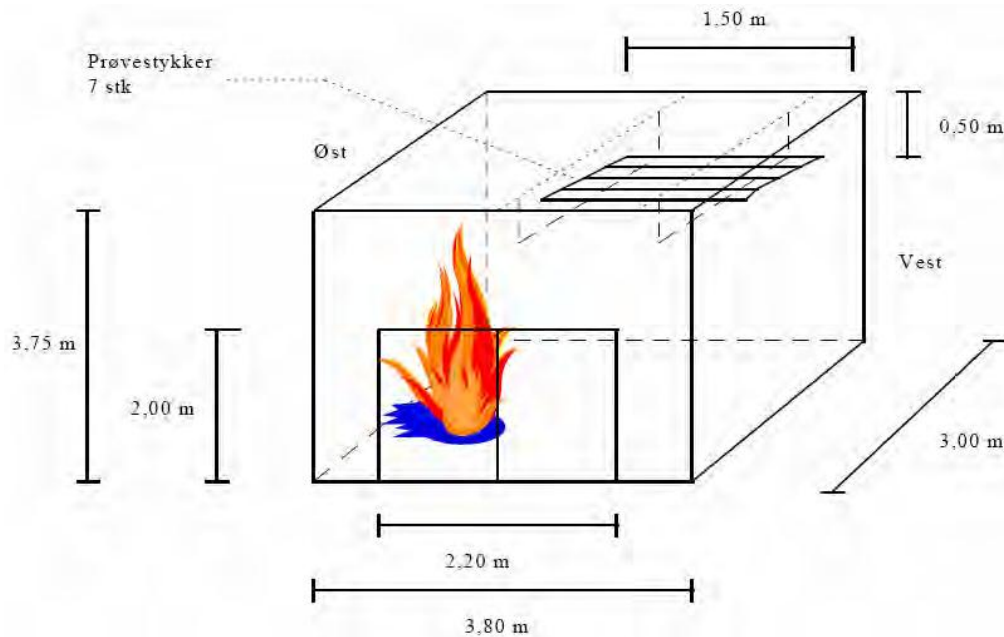

Figure 2. General fire test set up for Norwegian extinguisher tests [Jensen, 2006]

A wood pallet fuel package ignited by kerosene was used. Details of this fuel package are unreported, but it is noted that accuracy of the experiments was limited by these fuel configurations. Photographs show a step-pallet arrangement with dimensions of 0.6–0.9 m (2–3 feet). The Class A fire made of slat-like pallet materials, as opposed to crib “stick” material (see Figure 3). Presumably, the same Class A pallet material was used for both the fire/smoke exposure and suppression tests.



Figure 3. Class A pallet fire in Norwegian extinguisher tests [Jensen, 2006]

Specimens were mounted 0.5 m (1.6 ft) below the ceiling as show in Figure 2. Individual test materials generally measured 10 x 20 cm (3.9–7.9 in.). Materials that could not support themselves were mounted on acid free cardboard, pinned down using zinc covered iron nails. The support was a 2 m (6.6 ft) long wooden board.

Temperatures were monitored. Apparently there was an attempt to control temperatures to the 160–200°C (320–392°F) range. Exact details are unclear. There was no attempt to control humidity; it was noted that fires create humid conditions. The general fire test sequence lasted 15 minutes. When an extinguisher was used (fire or no fire), it was discharged for ten seconds.

For fire scenarios, the kerosene fire was ignited. At 2 min 40 sec the mechanical ventilation was secured, and the doors (non-air tight) secured at 3 minutes. Between 6 and 14 minutes, the fire burned so that the temperature was in the range of 160–200°C (320–392°F); the goal was to control the temperature rise. In some cases, single point temperatures exceeded 200°C (392°F). The exact location of the temperature measurements is unclear. At 14 minutes, the test secured. At 15 minutes samples were removed from the space.

Non-fire extinguisher discharge tests were performed with the samples laid on the floor of the chamber. Apparently, materials were allowed to cool until they reached 50°C (122°F) before agent was applied directly to the samples.

Following application of the suppression agent, each individual test material was wrapped in plastic and kept at 3°C (37°F). The plastic packaging was subsequently removed and the test

material was placed indoors to dry at 17°C (63°F) for 24 hours. This method was accepted as representative of a real situation. At this point the material was examined at 3x magnification and visual observations noted by a technical curator. If there were any question about effects, materials were subsequently examined under a microscope at 10x magnification.

Mechanical effects were qualitatively assessed. Powder extinguishers were judged to have a high impact and power of the stream. No comment was made about the CO₂ impact. Water mist was judged to have a lower stream power than powder extinguishers, although still sufficient to overturn, smash, or tear valuable materials. In the comparative matrix, CO₂ and dry powder are judged to be equal in mechanical effects, with the water mist judged to have less mechanical impact.

An acid free cardboard sample was placed below the cotton sample to assess acidity. Bromothymol blue, which without color change has a pH value of 5.7–7.6, was used as a pH indicator in the tests. In one test, a more precise assessment was made (methodology not reported) which indicated a pH of 7.2.

9.1.2 NRC Extinguisher Tests

Section 7.2 describes tests by the NRC to assess portable clean agent extinguisher TDPs. FTIR instrumentation was used. A similar set up/approach could be used for a standardized fire test assessment. Details are provided in the NRC report [Su and Kim, 2002].

9.1.3 Cable Fire Scenario

It has been noted that fires are rarely generated directly on collections [Jensen, 2006]. However, collections have become involved because they are in very close proximity to the fire source. An electrical fire at the Smithsonian Institution ignited a collection object on display [IGP AS, 2000]. The fire was quickly extinguished with a portable extinguisher, but conservators had to declare the object a total loss.

One method to assess the effects of HC1 is to create a cable bundle test. This scenario is representative of the primary fire hazard associated with electronics space sub-floors. An example Class C electrical scenario is a cable bundle consisting of twenty-five 77.5 cm (30.5 in.) lengths of coaxial cable (Belden Cable Co. 8237) with a nominal exterior diameter of 0.6 cm (0.25 in.). The cable lengths are tied with three lengths of tie wire to two tubular heaters rated at 925 W @ 240 V (Chromalox STRI-3648/240). The heaters are energized with 251 V for total heat output of 2.02 kW, 1.01 kW each. The cable bundle is mounted behind a baffle on a simulated cable tray on top of a 1.3 cm (0.5 in.) thick sheet of gypsum wallboard. This setup is illustrated in Figures 4 through 6.

The cable bundle smolders for approximately 9 minutes prior to transitioning to flaming combustion. The resultant fire peaks at approximately 15 kW and is nominally maintained at that level for 10 to 15 minutes with the power to the heaters remaining active. If the power is secured, the fire slowly fades.

While the cable bundle/sub-floor scenario per se is not of particular interest for collection scenarios, the concept may be useful if an initiating Class C electric cable fire scenario is of interest. Instead of a cable bundle, one or two cables could be useful with an electric heater to create a Class C ignition source. Additional cable or Class A material could be located adjacent to this igniter to create a small Class C/Class A fire scenario.

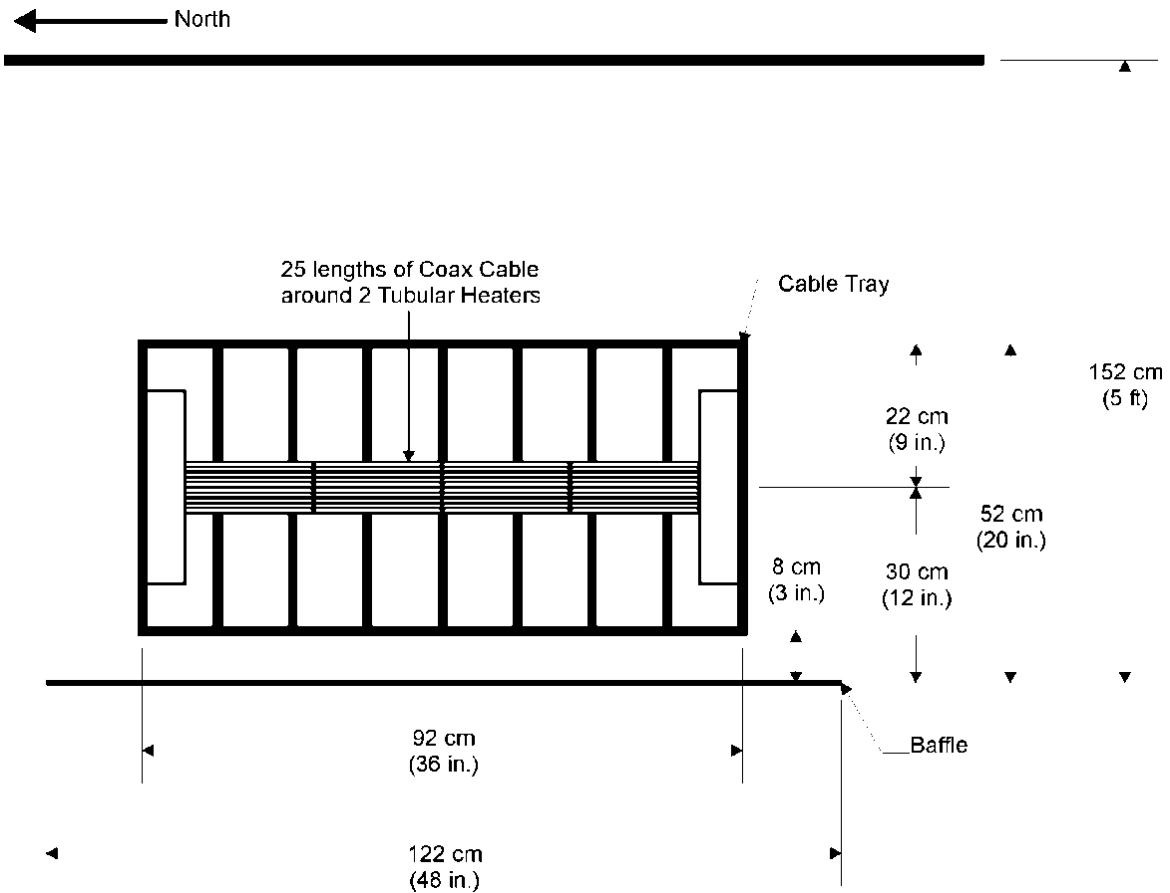

Figure 4. Cable bundle fire scenario setup – plan view

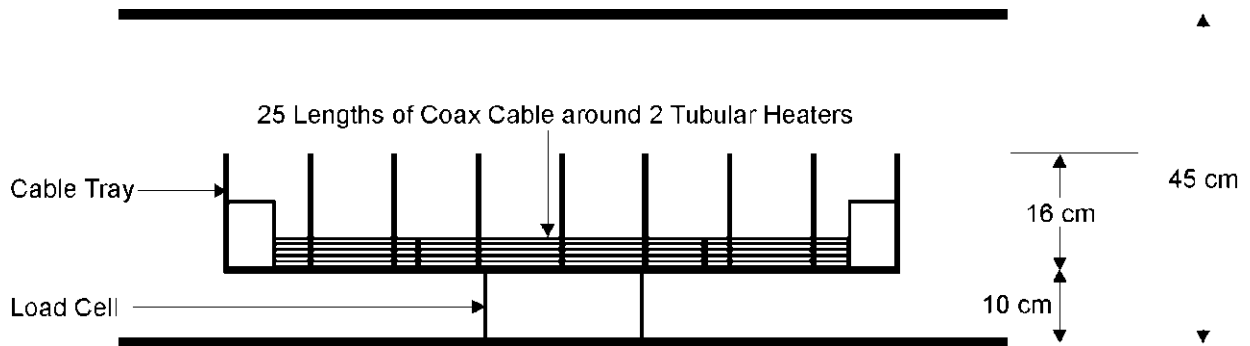

Figure 5. Cable bundle fire scenario setup – elevation view



Figure 6. Cable bundle in sub-floor

9.2 Specific Measurement Techniques

9.2.1 Gas Concentrations

Several methods have been employed in previous testing to measure gas concentrations of typical TDPs. Four techniques were identified including Fourier Transform Infrared (FTIR) Spectroscopy, Near Infrared Tunable Diode Laser (NIR-TDL) Spectroscopy, Ion Specific Electrodes (ISE), and Magnetic Sector Mass Spectrometer (MSMS).

Fourier Transform Infrared (FTIR) Spectroscopy is based on the principle that infrared radiation is absorbed at certain wavelengths depending on the structure of the molecule. The FTIR passes infrared radiation through the sample being analyzed. The intensity of the transmitted infrared radiation is recorded by a detector and presented as a plot of intensity versus wave number (reciprocal of the wavelength). By comparing the plot of the gas sample to plots of premixed samples with known concentrations, the concentrations of various compounds can be determined. One advantage of the FTIR is that it allows for simultaneous measurement of multiple compounds [Dierdorf, Moore, and Skaggs, 1993]. This assumes that the absorbency frequencies of the various compounds being analyzed do not interfere. Another advantage is that the FTIR can measure concentration in-situ. This allows for real time measurements and eliminates the need for sample tubing and sample bags/cylinders required with other techniques.

The open path configuration of an FTIR (Fourier Transform Infrared) spectrometer is utilized to avoid the line losses than can occur when drawing a sample into a cell for analysis. In this configuration, the measurement beam is directed to where gas is to be analyzed.

The analysis of the gas is the same whether an open path or a cell is utilized. The spectrum obtained is compared to the reference or calibration spectra obtained with a known concentration and path length of a specific gas. The concentration is determined by the ratio of the absorbance peaks between obtained spectrum and the calibration spectra. The detection limits for a gas depends on the ability to discern an absorbance peak from the baseline for the lower limit and the complete loss of intensity or saturation at the specific frequency where the absorbance is no longer linear with increasing concentration. The actual concentration at either limit depends on the specific gas to be analyzed, the path length of the measurement beam, number of averaged spectra (technique used to reduce the background noise), background intensity (alignment of optics, path length), and the resolution of the spectrometer.

With a path length of nominally 1m (3.2 ft), a 4 cm^{-1} resolution spectrometer should have a lower detection limit of approximately 70 ppm HF and approximately 100 ppm HCl. This path length would also allow for the FTIR to be installed outside of the exposed array of representative materials.

Near Infrared Tunable Diode Laser (NIR-TDL) Spectroscopy uses a similar method to the FTIR. In this case, a laser is passed through the sample instead of infrared radiation and is absorbed at certain wavelengths depending on the structure of the molecule. NIR-TDL offers the same ability to measure in-situ. Unlike the FTIR, the NIR-TDL is tuned to target certain wavelengths. This restricts the ability to measure multiple compounds simultaneously, but also may allow for more precise measurements of a given compound. Testing has shown the ability to measure HF and HCl concentrations below 1 part per billion for a one second measurement time at room temperature [Bomse, Silver, and Stanton, 1994].

The use of Ion Specific Electrodes (ISE) is a relatively cheap method of measuring concentrations. Unlike the in-situ measurements possible with the FTIR and NIR-TDL, gas samples are drawn from the test enclosure. The sample is bubbled through an aqueous solution, which traps the ions. The trapping solution can either be stored in a cylinder or bottle so that an average concentration over a given time is calculated or the solution can be continuously pumped through an electrode flow cell for continual measurement. An electrode specific to the particular ion being measured is used to determine the concentration of the trapping solution. In the case of HF measurements, a fluoride specific ion electrode is used. Because this electrode measures the total fluoride ion concentration, it cannot differentiate between HF and carbonyl fluoride (COF_2), another TDP of clean agents [Miser et al., 1998]. Since the electrode is specific for a particular ion, it does not have to the ability to measure concentrations for a variety of compounds simultaneously.

The Magnetic Sector Mass Spectrometer (MSMS) uses a high energy electron beam to fragment molecules into ions that are accelerated and focused into a magnetic field [Filipczak, 1993]. The path of the ions in the magnetic field is dependent on the mass to charge ratio of the particles, and by varying the magnetic field, the ions can be directed to a collector and measured [Filipczak, 1993]. The MSMS method requires that a sample be drawn from the test enclosure and transported to the instrumentation. The sample can be scanned for various ions.

9.2.2 Humidity

The humidity of the air can be measured using several of different methods. The most commonly used method for continuous monitoring is based on electronic capacitive sensors. These sensors consist of a hygroscopic layer sandwiched between two conductors, one of which is porous. The presence of water in the hygroscopic layer changes the capacitance between the two conductors. The amount of water absorbed into hygroscopic layer is proportional to the humidity of the surrounding air. The layers of the sensor are kept thin to minimize the response time of the sensor.

Another technique is infrared spectroscopy, both multi-frequency techniques (like the FTIR), and single frequency or narrow frequency band techniques (NDIR). The presence of varying amounts of water vapor in ambient air require inactive portions of these instruments to be sealed or purged to prevent measurement errors or losses in resolution.

9.2.3 Physical Impact Tests

A physical impact test could be used to assess the damage to items in cultural resource collections caused by the force of the agent stream. Two impact measurement methods might be used. The first method provides a means of quantifying the force of the agent stream. Based on the results, a relationship would have to be drawn between the forces measured and the impact on the items in question. The second method would assess the impact directly on materials expected to be found in cultural resource collections. The impact force would be expected to be a function of the distance between the extinguisher nozzle and the target, discharge mass flow rate, and physical state of the extinguishing agent (liquid, gas, or solid).

The first method measures the impact force directly using instrumentation. The agent would be discharged onto an appropriately sized board attached to a load cell or strain gauge located a preset distance from the operator. This would allow the total force to be recorded; however, a force per unit area is likely to be a more useful tool. This value could be obtained by approximating the impact area of the agent stream on the board. One possible method to approximate the area is to cover the board with a material likely to retain the agent so that the discharge pattern can be examined and measured after each test. The results could then be compared against estimates using photography or videography to confirm the measurements.

The major drawback of direct measurement is determining how to relate the calculated forces to the potential to damage a cultural resource item. Either values for the maximum force or pressure would have to be provided by experts in the field of cultural resources or the values could simply be used to rank the different agent extinguishers. The tests would identify which agents could cause the most damage relative to all agents tested.

To avoid the need to develop a relationship between calculated forces and the impact on cultural resource items, the second method tests the extinguishers against sample items in a manner similar to the Norwegian/COWI tests. Common materials that would be expected to be susceptible to physical damage such as paper, photography, glass/ceramic and paintings would be included. Materials not expected to be damaged such as metalwork and stone could be excluded. The extinguisher would be discharged until empty from a preset distance onto the test

material. Discharging the entire contents of the extinguisher would provide worse case results and remove any issues that could be raised regarding flow rate variations between different extinguishers. After each test, the material would be examined for signs of damage. A separate test would be required for each material and extinguisher combination.

A combination of the two methods is possible. The direct force measurement could be used to group agents into categories defined by the range of pressures recorded (low, medium, high). As new agents are developed, they may have to be grouped separately. Representative samples from each category could then be tested on actual cultural resource items using the second test method. This would significantly reduce the number of tests performed on cultural resource materials.

Regardless of the method selected, the distance from the operator to the measurement point must be defined. The length of the agent stream can vary significantly between agents and possibly even vary between extinguishers using the same agent but manufactured by different companies. The effective ranges for several extinguishers are presented in Table 6. This is the data reported by the manufacturers. No method to quantify this is included in UL 711. The range also varies with time as the discharge pressure decays. The difference in effective ranges suggests that the preset distance from the operator to the measurement point will need to vary based on the extinguisher. To test to the worst case scenario, each extinguisher should be tested at the minimum of the effective range specific to the agent/manufacturer.

Table 6. Effective Ranges for Portable Extinguishers

| Agent | Effective Range (m (ft)) |
|---------------------------|-------------------------------------|
| ABC Dry Chemical | 3.7–5.5 (12–18) |
| CO ₂ | 0.91–2.4 (3–8) |
| HFC-236fa (FE-36) | 4.3–4.9 (14–16) |
| HCFC Blend B (Halotron I) | 3.7–5.5 (12–18) |
| Water Mist | 3.0–3.7 (10–12) |

Note – ranges taken from manufacturers published literature

It should be noted that the effective ranges are based on operation of the extinguisher in a fire fighting capacity. Impact from acts of vandalism, where the effective range is not a consideration, may warrant investigation. In this case, the preset distance from the measurement point would have to be selected based on existing data from previous accounts of vandalism and would not vary based on the type of extinguisher.

9.2.4 Deposition Measurements

The method used to determine the amount of a substance deposited on a surface varies by substance. For some powders, this could be performed by sweeping or vacuuming up the powder from a known area and weighing the amount of the powder collected. A collection pan could be weighed before and after exposure to determine the amount deposited over the surface area of the pan for some liquids and powders. For some materials, liquid samples may be

obtained for analysis, by cleaning the surface of the object with the solvent or by exposing the solvent in a pan. The liquid samples could then be analyzed utilizing an Ion Specific Electrode.

The direct measurement of the amount of deposition is problematic in that it involves the subtraction of two larger values to resulting in a smaller value. This magnifies the error in the measurements in the pre-exposure and post-exposure mass measurements. The practical means to minimize the error is to minimize the weight-to-exposed surface area ratio of the exposed object. This maximizes the ratio of the deposited mass to the mass of the exposed object.

There are several spectral techniques to analyze solid surfaces: XPS, SEER, ATR. However, these methods utilize a clean polished surface to interact with the spectral beam to determine the composition of the analyzed solid. Potentially, these methods could be used to measure the amount of corrosion that has taken place on the surface. They will not tell you the amount of a material that has been deposited.

In addition to the direct measurement, the amount deposited could be determined by analyzing the deposited mass, vacuumed off the surface onto a filter that can then be weighed. If the material deposited can be dissolved into a cleaning solution, then the measurement could be made from the concentration of the material in the solvent. Both of these methods would interfere with the analysis of the effects of the deposited material on the exposed object. The direct measurement technique is recommended to avoid this interference.

9.2.5 Suspended Powders and Liquids in Air

The mass of a powder or a liquid suspended in air (water mist or powder extinguisher) might be measured utilizing an optical density meter which measures the drop in light intensity over a known path length. As the correlation between the mass concentration and the optical density is dependent on particle/droplet size and the species, calibrations with known concentration or other measurement techniques would be needed.

The suspended mass of a powder or liquid can also be measured utilizing a gravometric technique. A sample of the suspended powder or liquid is drawn through a trap which collects the powder or liquid. The trap is weighed before and after the sample is drawn to determine the mass suspended in the collected sample.

10.0 DISCUSSION OF TEST PARAMETERS

10.1 General Approach to Assessing Extinguisher Impact

Three basic types of tests might be performed to evaluate the impact of portable extinguishers. These types are:

- Type 1 – Exposure of representative materials to environments simulating post-extinguisher discharge. This would be a controlled environment test, with no fire;
- Type 2 – Measurements of the deposition and exposure on objects within and outside of the extinguisher spray pattern. This would involve a more realistic exposure/fire scenario, but deposition would be tightly controlled using experimental techniques instead of actual collection materials; and,

- Type 3 – Exposure of representative materials within and outside of the extinguisher spray pattern. This would be representative of a realistic, collection situation.

One or several of these tests might be conducted to derive the desired data. The following sections describe the general approach of each test. The advantages and disadvantages are then summarized.

Mechanical impact tests can be conducted separately, and independent of the agent impact tests.

10.2 Exposure of Representative Materials to Environments Simulating Post-Extinguisher Discharge

These tests would expose representative materials to environments simulating post-extinguisher discharge in a controlled manner. This would allow for the development of correlations between concentration/exposure dosage and the impact on the materials. Variables to be investigated include:

- Agent concentration/deposition;
- Decomposition product concentration/deposition;
- Duration of exposure;
- Humidity;
- Temperature; and
- Cleaning method (optional – to be assessed by independent museum conservators).

Tests would be conducted in an environmental chamber where the temperature and humidity can be controlled. The representative material would be installed in the chamber. The agent or decomposition product would either be introduced to the chamber or deposited on the material. At the end of the exposure the chamber would be vented, agent/decomposition product removed and the material examined for impact of the exposure.

As an example: materials would be exposed to monoammonium phosphate (ABC powder) at three surface deposition levels (g/cm^2 (oz/in.^2)) with constant relative humidity, temperature, and exposure duration to assess the impact of the ABC deposition level on the materials. Composition of the environments utilized would be based on either previous studies from the literature or based on new tests (i.e., Type 2 and/or Type 3 tests). The literature is sparse and deposition of agents would have to be approximated.

10.3 Measurements of the Deposition and Exposure on Objects Within and Outside of the Extinguisher Spray Pattern

These tests would measure the deposition and exposure duration for both vertical and horizontal surfaces both within and outside of the spray pattern of the portable extinguisher. These would include both fire tests and non-fire tests. The fire tests would involve measurements of exposure to/deposition of fire by products, agent and agent decomposition

products. The non-fire tests would involve measurements of exposure to/deposition of the neat agent. The set-up for this type of tests is given schematically in Figure 7.

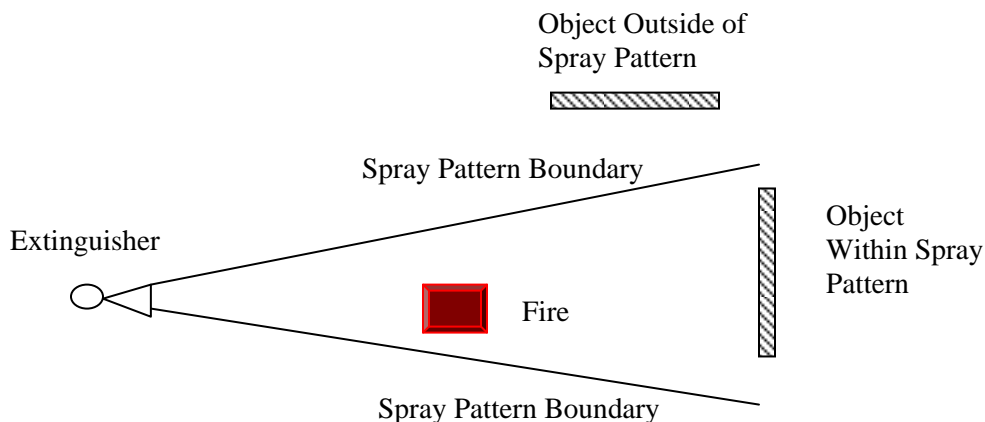

Figure 7. Deposition and exposure test schematic

Variables to be investigated include:

- Agent;
- Fire size;
- Distance between extinguisher and fire;
- Distance between fire and objects inside spray pattern;
- Off-set distance spray pattern and objects outside of the spray pattern; and
- Orientation of objects (horizontal/vertical surfaces).

The agent and decomposition product concentrations would be monitored both within the spray pattern and outside of the spray pattern. The deposition of the agent and the associated decomposition products on the objects would be measured. The objects used would be sections of walls, shelves, etc. chosen for ease in making the deposition measurements. They would not representative materials to be inspected for impact of the exposure.

10.4 Exposure of Representative Materials Within and Outside of the Extinguisher Spray Pattern

These tests would involve the direct exposure of representative materials both within and outside of the extinguisher spray pattern. Both fire tests and non-fire tests would be included. The impact of the exposure on the representative materials would be directly assessed. This impact could be used as confirmation of the evaluations conducted with simulated post extinguisher discharge environments (Section 11.1) and of the measurements of the resultant exposures to objects (Section 11.2).

These tests would be similar to those described in the previous section, except that the generic surfaces for the agent and decomposition products to deposit onto would be replaced

with representative materials that would be assessed for the impact of the exposure. Variables to be investigated include:

- Agent;
- Fire size;
- Distance between extinguisher and fire;
- Distance between fire and representative materials inside spray pattern;
- Off-set distance spray pattern and representative materials outside of the spray pattern; and
- Orientation of representative materials (horizontal/vertical surfaces).

The agent and decomposition product concentrations would be monitored both within the spray pattern and outside of the spray pattern. The deposition of the agent and the associated decomposition products on the representative objects would be measured. The representative materials would be examined for impact of the exposure.

10.5 Discussion of Approach and Direction of Testing

The decision on the type of testing to be performed is a function of the precision of data needed, and the cost of gathering the data. A comprehensive, scientific approach would use all three test types. The Type 2 deposition measurement tests would likely be performed first. This would provide environmental data (particularly deposition) which would be used to quantitatively bound the variables for Type 1 controlled exposure tests. Type 3 field exposure tests would provide verification data for the Type 1 and 2 tests.

Engineering data for code guidance could be derived from Type 1 or Type 3 tests conducted individually. Type 1 exposure tests would provide quantified impact data using controlled exposure techniques. Since the literature is sparse on the deposition of agents (i.e., the rationale for conducting Type 2 tests), the engineering results would be predicated on assumptions of agent depositions. This may be sufficient to provide code recommendations.

The Type 3 tests are similar to those conducted in the Norwegian (COWI) tests, with a greater number of parameters included. Impact would be assessed on actual collection materials. This would provide direct material impact data to the code making committees. Quantification of deposition effects would be limited to the materials tested.

Type 2 testing should probably not be conducted by itself, since the results for the non-collection materials require data/analysis associated with Type 1 and/or Type 3 testing.

After review and discussion with the NFPA Research Foundation Technical Panel, it was decided to pursue an enhanced Type 3 test program. This type program would provide the most directly applicable data on the impact of the use of portable extinguishers on actual collection materials. The results of this program can be directly applied to the Appendix A impact tables.

The test program will include three types of tests. They are physical impact tests, non-fire exposure tests and fire exposure tests. Physical impact tests will evaluate the forces exerted on

objects within the spray pattern of the extinguisher. It will be used to assess the potential for extinguisher flow to topple, tear or dislodge museum display items. These tests will use surrogate materials instead of actual artifacts. The non-fire exposure tests will evaluate the effects of portable extinguisher agent spray on representative materials both within and outside of the extinguisher spray pattern. The fire exposure tests will evaluate the effects of the portable extinguisher agent spray on the representative materials while the extinguisher is utilized to extinguish a fire involving Class A (solid) materials. The effects of a fire alone on the representative materials by itself will not be evaluated in this test program (see Section 6.3 for thermal impact information).

The methodology proposed in this program should provide repeatable protocols. Multiple sponsors and laboratories will be able to perform their own investigations yielding comparable results. This provides a method to validate the test specifications while confirming/extending the COWI test results. The goal is to provide a cost-effective, repeatable test method to allow comparison of test data between users.

Detailed protocols for the tests are given in Appendix B. It is anticipated that the first series of tests will require some “shakedown” experiments to fine tune and refine the test procedures and protocols. Section 11 provides an overall description of the tests and supporting rationale.

11.0 PROPOSED TEST PROTOCOLS AND SUPPORTING RATIONALE

11.1 Test Enclosure

The most important test parameter is the fire size to room volume ratio. Keeping this ratio low is consistent with the typical application of portable extinguishers, i.e., small fires in large spaces. Scenarios involving larger ratios are typically dealt with by fixed suppression systems, i.e., sprinklers, or left for the local fire department. Portable extinguishers also are not meant to develop a uniform agent concentration or application density throughout the enclosure, but are meant to develop a high concentration or application density locally at the fire, with lower concentrations elsewhere in the space. Keeping the fire size to room volume ratio low allows for the effects of this non-uniform agent distribution to be evaluated. A ratio of approximately 1.2 kW/m^3 is recommended which correspond to an enclosure size of nominally 300 m^3 with the 350 kW modified UL 1-A wood crib scenario. The minimum height should be on the order of 3 m (9.8 ft). From a practical standpoint, a minimum length or width dimension should be on the order of 6.1 m (20 ft).

Performing these tests within an enclosure allows for the initial ambient conditions to be controlled. This allows these tests to be more repeatable and to be more representative of the museum spaces of concern (there should be no active ventilation during the test). Generally accepted practice has been to regulate relative humidity between 40–70%, or $55\% \pm 5\%$. Current guidelines at the Smithsonian Institution call for $45 \pm 8\%$ relative humidity and $21 \pm 2^\circ\text{C}$ ($70 \pm 4^\circ\text{F}$) temperature controls [Erhardt et al, 2007]. Criteria for the proposed tests should be $21 \pm 4^\circ\text{C}$ ($70 \pm 8^\circ\text{F}$), with an RH control of $65\% \text{ RH} \pm 7\%$ for the exposure tests. This provides flexibility for testing. The RH range represents the upper range in the field, and is conservative (worst case) for potential acid gas deposition onto materials. Some judgment should be made in applying these criteria. Alternatively, this could be a variable in the tests.

Geometric factors are important test parameters as well. Deposition of either neat agent, or the agent decomposition products on an object would be effected by the relative positions of the portable extinguisher and the fire to the object. For non-gaseous agents and decomposition products, the orientation of the surface (horizontal or vertical) would also have an impact on the amount deposited on the object. These factors are discussed in Sections 11.5.1 and 11.6.2.

The enclosure should be constructed with solid materials representing normal building materials, such as gypsum wall board over a metal or wood stud frame. The wall board joints should be taped and spackled. The enclosure should be painted to provide a clean surface, nominally impervious to the portable extinguisher agents to be utilized.

An alternate enclosure material, such as steel, is an acceptable option.

11.2 Materials to be Tested

The materials to be exposed in an initial assessment should include materials similar to Norwegian (COWI) tests with additional materials for a more comprehensive set. The materials which should be exposed include:

Materials from the Norwegian (COWI) Tests:

- Wood – painted
- Iron
- Oil painting
- Leather
- Textiles – wool, cotton, linen
- Cardboard

Additional materials:

- Stone/Marble
- Fur/hair
- Glass/ceramic
- CDs/DVDs
- Paper/books
- Water color & acrylic paintings
- Photos/negatives
- Bone/ivory
- Other metals (brass, bronze, Cu, Al, steel)
- Artifacts displayed in an enclosure (box) – to be determined by test sponsors

These materials should be exposed, where possible, in the form of nominal 25 x 25 cm (10 x 10 in.) sheets. These sheets should be as thin as available to maximize the ratio of the exposed surface area to sample weight. This should facilitate the use of direct mass measurement of the deposition on the exposed material.

Control samples of the materials that are exposed during the fire and non-fire exposure tests should be prepared. They should be conditioned similarly to the exposed samples. These

samples would be bagged and packaged for examination by experts along with the exposed samples.

For the mechanical impact tests, surrogate materials, more easily damaged or dislodged than actual materials of interest, should be used. For the tests evaluating tear and puncture potentials, the surrogate materials would include:

- Plastic film
- Paper
- Canvas
- Metal foil

For tests evaluating toppling or dislodging potential, surrogate materials should be used (see Section 11.4).

11.3 Extinguishers to be Tested

Portable extinguishers to be included are those discussed in Section 2.0, applicable for use in a museum/cultural heritage type application. These extinguishers should have a minimum UL 711 2A rating for A:B:C or A:C fires with the exception of the CO₂ extinguisher that is not rated for Class A applications. Currently available extinguishers meeting these criteria include the following agents:

- ABC Dry Chemical (monoammonium phosphate)
- IG-001 (CO₂ – carbon dioxide)
- HCFC Blend B (Halotron I)
- HFC-236fa (FE-36)
- Water Mist

Carbon dioxide, CO₂, is included even though it does not have a Class A rating and would therefore may not be applicable to many museum/cultural heritage scenarios. It is included because of its common usage and for comparison purposes.

The monoammonium phosphate (MAP) content of the ABC extinguisher should be at least 85%. Units are available with less MAP concentration. They would be expected to have less chemical impact than higher concentration units. These lower concentration units may also be tested at the discretion of the test investigator.

11.4 Physical Impact Tests

The physical impact of the extinguisher flow on an object in terms of the potential to dislodge, topple or tear is related to the impact force or exerted pressure on the object. The impact force can be determined from a momentum balance performed upstream and downstream of deflection of extinguisher stream at the object [Robertson and Crowe, 1975]:

$$F_{\text{impact}} = M_{\text{ext}}(V_{\text{up},x} - V_{\text{down},x})$$

where F_{impact} is the impact force, M_{ext} is the mass flow rate of the stream from the extinguisher that is deflected, $V_{\text{up},x}$ is the velocity upstream of the deflection point in the x direction, and $V_{\text{down},x}$ is the velocity downstream of the deflection point in the x direction. The pressure exerted on the object, P_{impact} , would be the impact force divided by the impact area, A_{impact} :

$$P_{\text{impact}} = F_{\text{impact}}/A_{\text{impact}}$$

Table 7 gives the estimated maximum impact force just downstream of the discharge orifice for the types of extinguishers to be utilized during these tests. All mass and discharge time data in this section is taken from manufacturers' specifications. The mass flow rate given in Table 7 is the average over the entire discharge (charge mass/discharge time). The velocity at the orifice was estimated with an orifice equation utilizing the initial charge pressure of the extinguisher as follows:

$$V_{\text{orifice}} = (2g\Delta P_{\text{initial}}/\rho_{\text{fluid}})^{0.5}$$

V_{orifice} is the velocity at the orifice, g is the acceleration due to gravity, $\Delta P_{\text{initial}}$ is the pressure difference across the orifice, and ρ_{fluid} is the density of the flowing fluid. As this does not account for sonic flow through the orifice, this velocity would be overestimated when sonic flow conditions exist (CO_2 , HFC-236 and HCFC Blend B). The impact force is the product of the mass flow rate and the velocity. The impact force given in Table 7 does not account for the variation over the discharge of the mass flow rate, or for potential sonic flow conditions at the orifice.

Table 7. Extinguisher Flow Rates at Maximum Impact Force (at Flow Restricting Orifice)

| Extinguisher | Rating | Mass | | Dis-charge Time [sec] | Mass Flow Rate | | Velocity (at Orifice) | | Maximum Impact Force (at orifice) | |
|---------------------------|----------|------|------|-----------------------|----------------|--------|-----------------------|----------|-----------------------------------|-------|
| | | [kg] | [lb] | | [kg/s] | [lb/s] | [m/s] | [ft/sec] | [N] | [lbf] |
| ABC Dry Powder | 2A:10B:C | 2.3 | 5.0 | 14 | 0.16 | 0.36 | 58 | 191 | 9 | 68 |
| CO_2 | 5B:C | 2.3 | 5.0 | 10 | 0.23 | 0.50 | 123 | 403 | 28 | 201 |
| HFC-236 (FE-36) | 2A:10B:C | 6.0 | 13.3 | 13.5 | 0.45 | 0.98 | 27 | 90 | 12 | 88 |
| HCFC Blend B (Halotron I) | 2A:10B:C | 7.0 | 15.5 | 14 | 0.50 | 1.11 | 27 | 90 | 14 | 99 |
| Water Mist | 2A:C | 6.8 | 15.0 | 72 | 0.09 | 0.21 | 41 | 136 | 4 | 28 |

As can be seen, the impact force for these extinguishers is similar with the exception of CO_2 which is double the next highest and water mist which is half the next lowest. The force calculation for CO_2 is deceptive; the nozzle design for CO_2 extinguishers has the liquid agent discharging transversely against the side of the nozzle cone/horn, allowing the agent to vaporize and expand to fill a much larger cross-sectional area and flow with much reduced velocity and impact force potential. This reduces the nominal impact force.

The velocity of the extinguisher flow decreases and the cross-sectional area of the flow increases as it flows away from the extinguisher nozzle. This is due to the entrainment of the surrounding air as well as the flow resistance of the ambient air. The entrainment of air is driven by the velocity difference between the nozzle flow and the surrounding air. The rate of entrainment is therefore non-linear. For HCFC Blend B (Halotron I) and HFC-236fa (FE-36), which are stored as a liquid and vaporize during the discharge, the prediction of the upstream flow rate is more difficult.

11.4.1 Physical Impact Test Variables

The physical impact tests should be conducted using the distance between the portable extinguisher and the object as a variable (separation distance). The effective ranges for the portable extinguishers (manufacturers' data) are given in Table 6. The tests should be conducted with two distances. A 0.9 m (3 ft) separation distance should be utilized in the first set of tests representing a vandalism type scenario. A separation distance of 3.1 m (10 ft) set represents the use of an extinguisher at its nominal effective range. As the effective range for a CO₂ extinguisher is less than 3.1 m (10 ft), it should be tested at 1.8 m (6 ft), its average effective range.

11.4.2 Physical Impact Test Apparatus and Procedures

Two apparatuses should be used during these tests. The first of these will be used to evaluate the potential of the extinguisher flow to cause tears or punctures in materials. The extinguisher should be discharged onto the center of a sample material at the desired separation distance (Figure 7). The test material should be rigidly mounted on a 30 x 30 cm (12 x 12 in.) frame constructed of trade 5 x 5 cm (2 x 2 in.) lumber. The frame should then to be attached to the wall of the enclosure at nominally 1.2 m (4 ft) above the floor, the same height as the nozzle of the extinguisher. The purpose of the enclosure is to provide a wind free, 21 ± 4°C (70 ± 8°F) conditioned environment. Conditioning is important for repeatable extinguisher discharge characteristics.



Figure 7. Tear potential test apparatus

Surrogate materials that are as easy or are easier to tear than the typical cultural heritage items should be used. The recommended surrogate materials are: plastic film (.02–.04 mm (0.8–1.5 mil) thickness), aluminum foil (.025–.04 mm (1–1.5 mil) thickness), newsprint (40–50 g/m² (8-10 lb/1,000 ft²)) basis weight, and artist canvas (550 g/m² (5 oz/yd²), pre-primed and stretched.

The portable extinguisher should be discharged towards the center of the material. After the discharge of the extinguisher, the surrogate material should be checked for tears, cracks, and distortions.

The second impact test will be used to evaluate the potential of the extinguisher flows to topple or dislodge an object. The extinguisher should be discharged at the top of a wood block as illustrated in Figure 8. The block will be set on end on top of a stand, nominally 1.2 m (4 ft) above the floor, at the same height as the nozzle of the extinguisher. These tests should be performed inside an enclosure to provide a wind free, $21\pm 3^{\circ}\text{C}$ ($70\pm 5^{\circ}\text{F}$) conditioned environment.

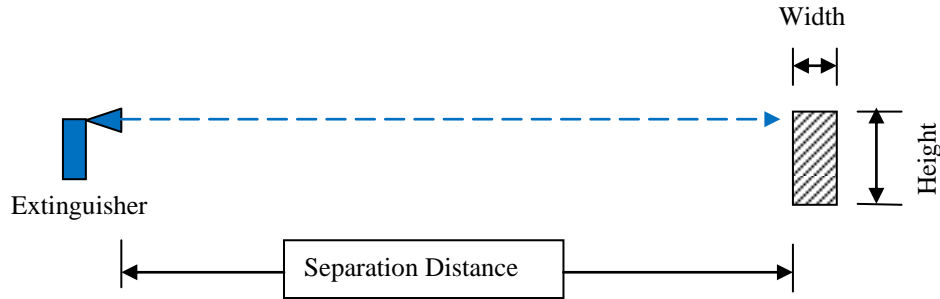

Figure 8. Topple potential test apparatus

The stand should provide a smooth, flat, and level surface on which to place the test block. The blocks should be made from white pine or similar material with a nominal density of 430 kg/m^3 (26.8 lb/ft^3), $\pm 10\%$. A series of blocks should be tested, with each block easier to topple than the previous one as given in Table 8.

Table 8. Estimated Force to Topple Objects

| Object | Dimensions | | | | | | Mass | | Required Force to Topple | |
|--------------|------------|------|-------|------|--------|------|------|------|--------------------------|-------|
| | Length | | Width | | Height | | | | | |
| | [cm] | [in] | [cm] | [in] | [cm] | [in] | [kg] | [lb] | [N] | [lbf] |
| Wood Block 1 | 8.9 | 3.5 | 8.9 | 3.5 | 50.0 | 19.7 | 1.70 | 3.75 | 1.48 | 0.33 |
| Wood Block 2 | 3.8 | 1.5 | 8.9 | 3.5 | 50.0 | 19.7 | 0.73 | 1.61 | 0.63 | 0.14 |
| Wood Block 3 | 8.9 | 3.5 | 3.8 | 1.5 | 50.0 | 19.7 | 0.73 | 1.61 | 0.27 | 0.06 |
| Wood Block 4 | 3.8 | 1.5 | 3.8 | 1.5 | 50.0 | 19.7 | 0.31 | 0.69 | 0.12 | 0.03 |

The extinguisher should be discharged at the top of the block from the desired separation distance. Any movement (sliding or toppling) should be noted.

Additional, heavier objects may be needed if it is found that the heaviest object topples for all extinguishers tested.

An optional third type of physical impact test would involve the direct measurement of the impact force and pressure exerted by the extinguisher jet on an object. A target plate, mounted on load cell, would be used to measure the force. A Forward-Looking Infrared (FLIR) camera would be used to measure the diameter of the extinguisher spray pattern just upstream of the target plate. This apparatus is shown schematically in Figure 9. The load cell would be mounted on the wall of the enclosure at a height of 1.2 m (4 ft) above the floor, the same elevation of the nozzle of the portable extinguisher. The tests would be performed inside the enclosure to provide a wind-free, $21\pm 4^{\circ}\text{C}$ ($70\pm 8^{\circ}\text{F}$) conditioned environment.

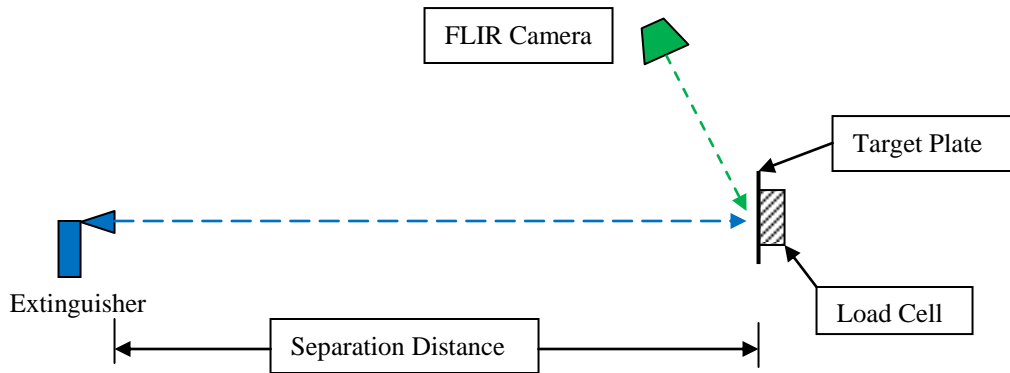

Figure 9. Optional physical impact direct measurement apparatus

The extinguisher would be discharged at the center of the target plate. The images from the FLIR would be analyzed to determine the diameter of the nozzle jet just upstream of the target plate. The determined impact area would be synchronized with the force measurements from the load cell to determine the pressure exerted by the nozzle jet on the target plate. This force data could then be used for analysis of specific displayed cultural heritage objects.

11.5 Non-Fire Exposure Tests

The objective of the non-fire exposure tests is to evaluate the effects of the neat agents on representative materials under normal environmental conditions. During these tests, the portable extinguisher should be discharged directly onto the representative materials from a distance representing the nominal effective range of the extinguisher. A second set of representative materials should be indirectly exposed. This second set of materials should be mounted outside of the extinguisher spray pattern to assess the effects of a collateral exposure.

11.5.1 Non-Fire Exposure Test Variables and Parameters

The controlling parameters of the non-fire exposure tests are the separation distance between the extinguisher and the directly exposed materials, the off-set distance of the indirectly exposed materials behind the extinguisher, the orientation of the exposed objects, and the elevation of the exposed objects with respect to the portable extinguisher. These parameters are illustrated in Figure 10. All of these parameters could be set as variables, but this would increase the number of tests considerably. Recommendations are provided to fix these parameters. At the discretion of the test sponsor, any of these parameters could be varied.

The separation distance from extinguisher nozzle outlet to the directly exposed object array should be within the effective range of the extinguisher discharge, but not less than 3.1 m (10 ft). For the carbon dioxide extinguisher, which has a shorter effective range, a separation distance not less than 1.8 m (6 ft) should be used. The close-in vandalism scenario is not included in the Appendix B test specifications.

The off-set distance of the indirectly exposed object array behind and offset from the center-line of extinguisher outlet should be 1.5 m (4.5 ft). The indirectly exposed material is close to the extinguisher discharge while out of the direct discharge flow.

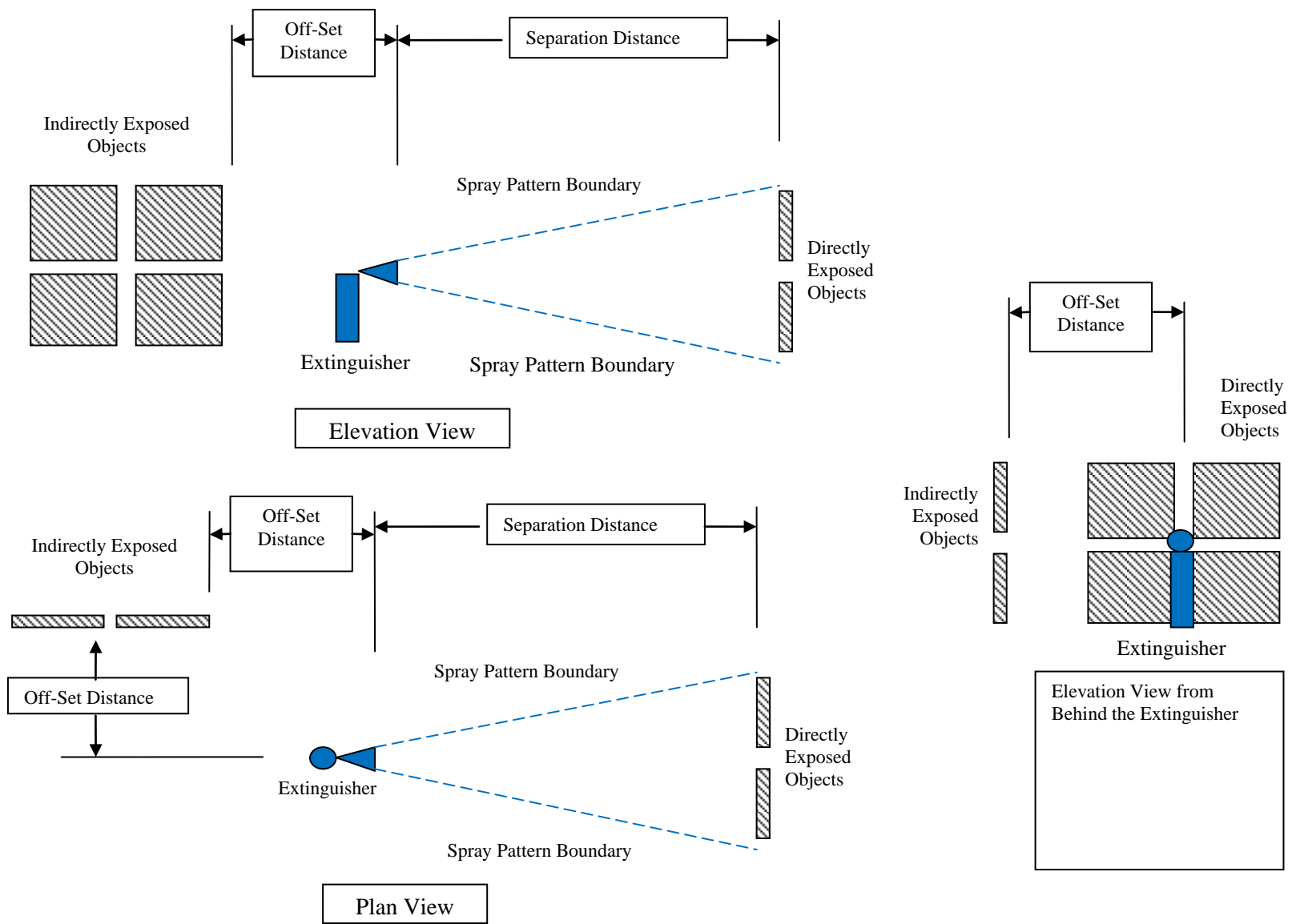

Figure 10. Non-fire exposure apparatus schematic

The directly and indirectly exposed objects should be mounted on the enclosure walls in a vertical orientation. This is representative of the orientation of the majority of cultural heritage items displayed. It is, however, not conservative with respect to the deposition amount of the agent on the object. A greater amount of the agent would be expected to be deposited on a horizontal surface than on a vertical surface. This could be included as a test variable.

The indirectly and directly exposed object arrays should be centered at the same elevation as the portable extinguisher nozzle outlet. This height should nominally be 1.2 m (4 ft) above floor.

11.5.2 Non-Fire Exposure Apparatus

The apparatus for these tests is shown schematically in Figure 10. The representative materials would be exposed in arrays of 4 materials each. This reduces the overall number of tests. This is predicated on the spray pattern of the extinguisher being wide enough to cover the nominal 55 x 55 cm (22 x 22 in.) area represented by the four material arrays. If this is not the case, then the number of materials in the array would need to be reduced and the number of tests to be performed would increase. Alternately, some judgment could be used to allow more specimens if cost of testing is prohibitive.

Two sets of representative material/object mounts should be used. They should be mounted on the back wall of the enclosure or on a stand in the vertical orientation. Indirectly exposed objects should be mounted on the side wall of the enclosure or on a stand.

A nominal 300 m³ (10,600 ft³) enclosure, as described in Section 11.1, should be used. A representative test cell measuring 10 x 10 x 3 m (32 x 32 x 10 ft) could be used. The 3 m (10 ft) ceiling height is representative of a small gallery and would be conservative with regards to vertical stratification of the agent flows in the space. The large enclosure volume allows for the agent exposure dynamics typically encountered in portable extinguisher scenarios, i.e., no significant homogenous build up of agent concentration in the enclosure.

The deposition would not be monitored during exposure but should be determined by weighing the objects both before and after the exposure. The temperature and relative humidity should be monitored outside of extinguisher spray. Temperature should also be monitored at the face of the directly exposed materials. This is particularly important for the CO₂ extinguisher tests.

For some of the tests, the agent concentration could be monitored as well. These measurements are considered optional. During tests with the ABC dry powder extinguisher, the powder density could be monitored utilizing an optical density apparatus. This apparatus utilizes a photodiode to measure the decrease in intensity from a laser light source due to absorbance and scattering due to the presence of the powder. The concentration/density of the powder aerosol is proportional to the amount of scattering or absorbance of the light beam. The correlation constant for ABC powder would need to be determined through comparison with gravimetric test data.

During tests with Halotron I or FE-36, the agent concentration could be monitored with an open path FTIR method. In this method, the active beam of the FTIR would be passed in front of the directly exposed objects. The agent concentration would then be determined by

comparison of the spectra obtained with spectra with known concentrations. When used in the fire exposure tests, the FTIR would also be used to measure thermal decomposition products (HF, COF₂, HCl).

During tests with the CO₂ extinguisher, the agent concentration could be determined with an NDIR analyzer configured for CO₂. With this technique, a low flow (6 LPM) gas sample would be withdrawn from the area near the directly exposed object and supplied to the analyzer. The gas sample would be dried in a cold trap and Drierite filter, with particulate removed in a sintered metal filter prior to being supplied to the analyzer.

11.5.3 Non-Fire Exposure Test Procedure

Prior to the start of the test, the enclosure should be conditioned to a temperature of $21 \pm 4^{\circ}\text{C}$ ($70 \pm 8^{\circ}\text{F}$) and a relative humidity of $65 \pm 7\%$.

Appendix B provides additional details on the discharge and test procedures. Some adjustments to the nozzle elevation/angle may be needed to direct the spray pattern to the center of the target. This should be determined in pre-test shakedown.

After the test, the exposed objects from both arrays should be removed from the enclosure and weighed. The objects should then be visually examined for any sign of damage due to the exposure. This examination should include checks for tears, cracks, distortions, residue, and discolorations. The objects should then be placed in a conditioned space (same temperature and RH) and allowed to dry for up to 24 hours.

Objects should then be examined again for damage as described in Section 11.7. Ultimately, the objects may be bagged and packaged for examination by experts.

11.6 Fire Exposure Tests

The objective of the fire exposure tests is to evaluate the effects of the combination of the agents, decomposition products and fire effluent on representative materials. The portable extinguisher will be used to extinguish a wood crib fire with the representative materials mounted nominally downstream of the wood crib. A second set of representative materials would be located outside of the direct discharge to assess the effects of a reduced exposure.

11.6.1 Fire Scenarios

Fires in ordinary (Class A) combustibles appear to be the most common and representative fire threat as described in Section 3.0. The initiating source may be a flammable liquid (Class B) in an arson scenario or faulty electrical equipment (Class C). The early stage magnitude of these threats cannot be quantified directly from the loss history, but standard extinguisher test methods and hazard techniques indicate a maximum threat limit on the order of 1 MW. A realistic scenario, approachable by an unprotected person using a portable fire extinguisher, is probably lower than 1 MW.

Large Class B fires (i.e., 1.2–2.3 m² spill fire associated with UL 5-B/10-B ratings) do not appear to be a likely scenario. While there are arson fires with initiators of this magnitude, it is

unlikely that the fire would be fought with an extinguisher. This scenario would more likely occur where employees/occupants are not present. Small amounts of flammable liquid could be used as an initiator in the arson scenario. This scenario is consistent with the standard UL Class A fire test, where heptane is used as an initiator. The UL extinguisher test method provides a good, repeatable test scenario representative of a collection fire scenario.

It was noted in the Huntington Gallery fire analysis that the greasy hydrocarbon smoke/soot was similar to wood smoke. The particulates and constituents are different. Because large Class B fires are rare, and when they occur cause substantial damage, a large Class B fire scenario is not recommended.

The magnitude of the Class A fire should be well below the limits of a 2-A rated extinguisher. When a test is performed, it is desirable to have a fire which is easily suppressed by the extinguisher. This eliminates the variable of whether or not the fire is extinguished. A Class A wood crib fire on the order of 200–500 kW is recommended.

An additional fire scenario might be a small Class C electrical fire. This would be a scaled-down version of the cable bundle fire, with additional Class A material along with the cable insulation. This scenario is desirable if the effects of fire acid gas (independent of acid gas produced by a clean agent extinguishment) are considered important. The drawbacks of such an approach are: the design cable loading (one–three strands of wiring) may be insufficient to create significant acid gas production; and, being a nonstandard test method, it would require shakedown to establish repeatability. This scenario is not included in the Appendix B test specifications.

A modified UL 1-A wood crib should be used. It has an estimated heat release rate of 350 kW, which is inside the recommended range and within the capabilities of a 2-A rated portable extinguisher. Modifications to the UL 1-A wood crib fire are recommended to reduce the pre-burn duration from 9 minutes to 3 minutes and to reduce the burn duration of the n-heptane pan fire used to ignite the crib from a burn duration of 2 to 4 minutes to approximately 1 minute. These changes are made to reduce the impact of the fire, in terms of heat and smoke, on the exposed materials prior to the activation of the fire extinguisher. These changes will make the fire easier to extinguish with the portable extinguisher, but it should remain enough of a challenge to affect the agent (decomposition) and allow for the evaluation of these effects downstream on the exposed materials. Shakedown tests of this procedure may be needed to fine tune this scenario.

11.6.2 Fire Exposure Test Variables and Parameters

The apparatus for these tests is shown schematically in Figure 11. The representative materials would be exposed in arrays of 4 materials each, similar to the arrangement utilized during the non-fire tests.

In addition to the parameters described in the non-fire exposure test, the separation distance between the wood crib fire and the directly exposed materials is a factor. The separation distance from wood crib fire to the directly exposed object array should be on the order of

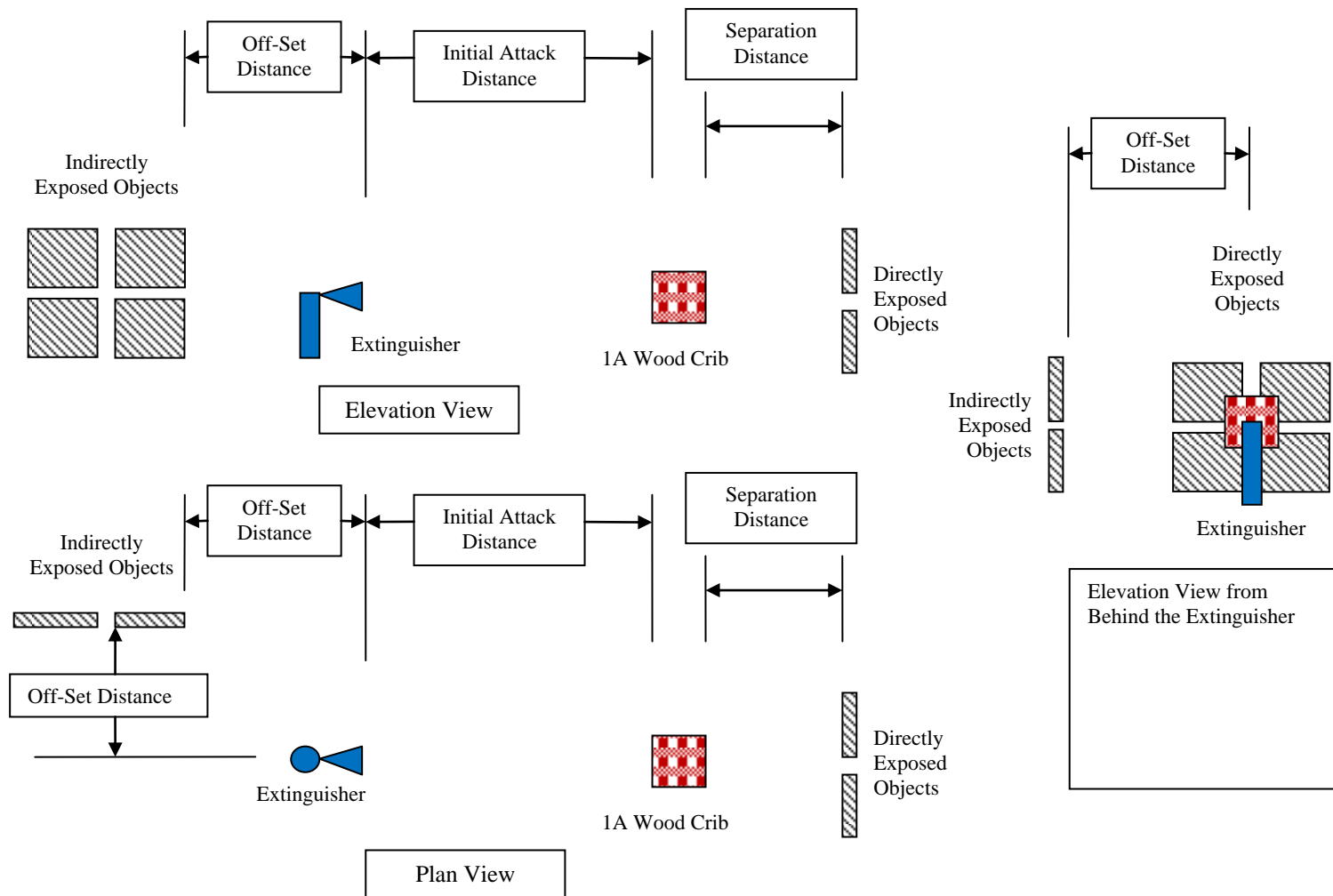

Figure 11. Fire exposure apparatus schematic

2.25 m (7.4 ft). This distance roughly corresponds to a radiative heat flux from the fire to the directly exposed objects of less than 2 kW/m^2 [Tien et al., 1998]. This low radiative heat flux should not thermally affect the exposed materials, but should expose the samples to the fire/extinguisher effluent during the fire suppression process.

The initial fire fighter attack distance should be 3.7 m (12 ft), representative of the effective range of the portable extinguisher. Carbon dioxide, CO_2 , will not be utilized during the fire exposure tests as it is not effective with respect to the wood crib fire.

As in the non-fire enclosure tests, the off-set distance of the indirectly exposed object array should be 1.5 m (4.5 ft). Exposed objects should be mounted on the enclosure walls or stand in a vertical orientation. A wall configuration is desirable to allow for wipe samples (see Section 11.6.3). A smooth exposure target, made of glass, ceramic, or stainless steel, could be positioned in the center of the target wall. This could be used as the wipe deposition sample standard.

The indirectly and directly exposed object arrays should be centered on the same elevation of the portable extinguisher nozzle outlet and the wood crib. This height should nominally be 1.2 m (4 ft) above floor.

11.6.3 Fire Exposure Apparatus

The material object mounts and fire test enclosure should be the same as in the non-fire exposure tests. The UL 1-A wood crib should be raised off the floor 0.9 m (3 ft), such that the centerline of the crib is aligned with the center of the array of materials to be directly exposed. All other test conditions should be the same as the non-fire exposure tests. As an option, agent concentration could be monitored; the use of the FTIR for acid gas measurement would have the most value.

Wipe samples will be taken from the enclosure wall near the directly exposed material array. The samples will be analyzed utilizing an ion specific electrode technique. The samples obtained will be analyzed for fluoride, chloride and pH.

11.6.4 Fire Exposure Test Procedure

Prior to the start of the test, the enclosure should be conditioned to a temperature of $21 \pm 4^\circ\text{C}$ ($70 \pm 8^\circ\text{F}$) and a relative humidity of $65 \pm 7\%$. Once the fire is initiated, these conditions will change. Appendix B provides additional details on the nominal discharge and test procedures. The fire should be manually extinguished, with the operator permitted to advance and suppress the crib fire. While the use of manual operation introduces variability, this can be addressed by using the same, experienced operator for all tests in a set. Immediately after suppression, there may be some residual smoldering of the crib. A method may be needed to eliminate this effluent exposure to target materials. This should be considered during scoping/shakedown tests.

The post test procedures should be the same as the non-fire test exposure.

11.7 Conservator Assessment of Exposed Materials

It is envisioned that materials will be provided by sponsoring agencies, who may also provide conservator expertise. For any given set of materials and exposure tests, one or more conservators should be enlisted to provide post-test assessment of the artifact(s). Material samples should be microscopically assessed for damage at appropriate post-test time intervals. Post-test time intervals of 1, 4, 16, and 24 hours, and 1 week and one month have been suggested.

At a minimum, assessments should be made within four hours and 12–14 hours after exposure by qualified investigator(s). It is anticipated that these examinations will be made at the fire test facility. The investigator(s) will likely advise and supervise the handling and shipment of the materials. Assessments will likely include the use of photo-micrographic equipment. Photographic documentation should be made during the examinations. Assessments should generally include identification of planar distortions, adhesion of soot or other by products (agents can be carriers of combustion products), accretions, acid effects including corrosion and embrittlement, stains, and discoloration. Near field deposition data will be directly collected and reported in the fire-exposed test protocol. Conservators can then advise on the impact of these deposition materials in general and for specific materials. For groups of materials, assessments of the following characteristics should be considered:

Most materials

- Soot deposition
- Deformation
- Expansion
- Contraction
- Scorching
- Charring
- Staining

Paper

- Embrittlement
- Staining
- Distortion
- Breakage (from weak, wet paper)
- Solubilizing of sizes/coating
- Feathering, sinking, or removing of media
- Charring
- Cockling

Scorching
Desiccation

Paint/finishes

Cracking
Shrinking
Oil/water gilding (covering/cracking)
Curling
Loosening/peeling
Solubilizing

Skin/leather

Becoming translucent
Sensitivity to expansion and shrinking
Gelatinization
Desiccation
Swelling
Stiffening
Blackening

Photographs/films

Shrinkage

Wood

Blooming (whitening)
Cracking/splitting

Hard materials (including metal and stone)

Fissures
Cracks
Discoloration
Crazing

Metals

Surface corrosion

Darkening
Tarnishing

Textiles

Changes in color
Shrinkage
Discoloration
Blotchiness

More detailed chemical analysis and associated clean up procedures for specific objects might also be included, subject to sponsor direction and conservator expertise.

12.0 REFERENCES

Ahrens, M. (1999), "Structure Fires in: Libraries, Museums or Art Galleries, Properties coded as Historic Buildings; and Churches Chapels or Mosques and Incident Descriptions of Fires in Libraries and Churches, Chapels and Mosques since 1996," National Fire Protection Association, Quincy MA, October 1999.

Amerex Corporation (2008), "Material Safety Data Sheet (for ABC Dry Chemical)," Amerex Corporation, Trussville, AL, September 2008.

American Pacific Corporation Halotron Division (2006), "Material Safety Data Sheet-Halotron I," Halotron, Las Vegas, NV, December 18, 2006.

American Pacific Corporation Halotron Division (2008), "Material Compatibility Charts-Halotron I Fire Extinguishing Agent," Halotron, Las Vegas, NV, August 2008.

Axley, J. (2007), "Multizone Airflow Modeling in Buildings: History and Theory," *HVAC & R Research*, **13** (6), November 2007, pp. 907–928.

Bagwell, S. (2004), "The Beauty of Science: New Technologies in Art Restoration," *Illumin Magazine*, **6** (i), University of Southern California, 2004.

Bishop Museum (1996), "Disaster Preparedness and Recovery for Works of Art on Paper," Honolulu, HI, retrieved from Bishop Museum Conservation Services, State Museum of National and Cultural History©1996, <http://www.bishopmuseum.org/research/pdf/cnsv-disaster.pdf>.

Bomse, D.S., Silver, J.A., and Stanton, A.C. (1994), "Hydrogen Halide Trace Detection using Diode Lasers," *Proceeding of Halon Options Technical Working Conference*, Albuquerque, NM, May 3–5, 1994.

Buckeye Fire Equipment Company (2007), "Material Safety Data Sheet-ABC Dry Chemical," Buckeye Fire Equipment Company, Kings Mountain, NC, July 2007.

Chemguard (2005), "ABC Dry Chemical Powder," Chemguard, Mansfield, TX, September, 2005.

Colton, B.A. (2009), "RE: FPRF Project and Halotron," e-mail to Joe Scheffey of Hughes Associates, Inc., July 29, 2009.

Dierdorf, D.S., Moore, T.A., and Skaggs, S.R. (1993), "Decomposition Product Analysis during Intermediate-Scale (645 ft³) and Laboratory Scale (3.18 ft³) Testing of NFPA 2001 Agents," *Proceedings of Halon Alternatives Technical Working Conference*, Albuquerque, NM, May 11–13, 1993.

DiNenno et al., (1993), "Evaluation of Alternative Agents for Halon 1301 in Total Flooding Fire Suppression Systems-Thermal Decomposition Product Testing," *Proceedings of Halon Alternatives Technical Working Conference*, Albuquerque, NM, May 11–13, 1993.

Dols, W.S., Walton, G.N., and K.R. Denton "CONTAMW 1.0 User Manual (2000)", NISTIR 6476, National Institute of Standards and Technology, Gaithersburg, MD, 2000

Druzik, J., (2003) "Preventive Conservation," *Decor*, posted by Conservation Resources International LLC, October 2003, <http://www.conservationresources.com/Main/S%20CATALOG/Preventative%20Conservation.htm>

Dumayas (1993), "The Effects of Corrosive Thermal Decomposition Products On Input/Output Cards, Produced When Halon Alternatives Are Used to Extinguish A Heptane Fuel Fire," Senior Research Project, University of Maryland, College Park, Maryland, 1993.

DuPont (1998), "DuPont HCFC-123 Properties, Uses, Storage, and Handling," DuPont, Wilmington, DE, 1998.

DuPont (2001), "DuPont FE-227 Fire Extinguishing Agent (HFC-227ea)-Properties, Uses, Storage, and Handling," DuPont, Wilmington, DE, 2001.

DuPont (2007), "DuPont FE-36 Fire Extinguishing Agent (HFC-236fa)-Properties, Uses, Storage, and Handling," DuPont, Wilmington, DE, 2007.

DuPont (2008), "DuPont FM-2000 Material Compatibility," DuPont, Wilmington, DE, 2008.

Erhardt, D. , Tumosa, C.S., and Mecklenburg, M.F.(2007), "Applying Science to the Question of Museum Climate", in *Museum Microclimates*, Copenhagen, Denmark, November, 2007

Filipczak, R.A. (1993), "Relative Extinguishing Effectiveness and Agent Decomposition Products of Halon Alternative Agents, *Proceedings of Halon Alternatives Technical Working Conference*, Albuquerque, NM, May 11–13, 1993.

Finnerty, A.E. and Vande Kieft, L.J. (1997), "Fire-Extinguisher Powders," *Halon Options Technical Working Conference*, Albuquerque, NM, May 6–8, 1997.

Flynn, J. (2007), "U.S. Structure Fires in Public Assembly Properties Excluding Eating and Drinking Establishments and Religious and Funeral Properties," National Fire Protection Association, Quincy MA, February 2007.

- Forssell et al. (2001), “An Evaluation of the International Maritime Organization’s Gaseous Agent Protocol,” *Fire Technology*, **37** (1), 2001, pp. 37–68.
- Haghighat, F. and Chérif Megri, A. (1996), “A Comprehensive Validation of Two Airflow Models – COMIS and CONTAM,” *Indoor Air*, **6** (4), pp. 278–288, April 2004.
- Hajpal, M. (2002), “Changes in Sandstone of Historical Monuments Exposed to Fire or High Temperatures,” *Fire Technology*, **38** (4), 2002, pp. 373–382.
- Hanauska, C.P., Forssell, E.W., and DiNunno, P.J. (1993), “Hazard Assessment of Thermal Decomposition Products of Halon Alternatives,” *Proceedings of Halon Alternatives Technical Working Conference-Poster Session*, Albuquerque, NM, May 11–13, 1993.
- Hughes Associates, Inc. (1995), “Hazard Assessment of Thermal Decomposition Products of FM-200 in Electronics and Data Processing Facilities,” Hughes Associates, Baltimore, MD, January 16, 1995.
- IGP AS (2000), “Fire Extinguisher for Museums and Historic Buildings,” report for Museum Development of Norway and the State Antiquarium, Troodheim, Norway, April 1998 (February 21, 2000 edition).
- Jacobus, M.J. (1986), “Screening Tests of Representative Nuclear Power Plant Components Exposed to Secondary Environments Created by Fires,” Sandia National Laboratories, Albuquerque, NM, 1986.
- Jenkins, J.F. (ed.) (1970), “Protecting Our Heritage: A Discourse on Fire Protections and Prevention in Historic Buildings and Landmarks,” National Fire Protection Association, Boston, MA, 1970.
- Jensen, G. (2006), “Manual Fire Extinguisher Equipment for Protection of Heritage,” Riksantikvaren Norwegian Directorate for Cultural Heritage (RNDCH), Oslo, Norway, 2006.
- Johnson, E.V. and Horgan, J.C. (1979), “Museum Collection Storage,” United Nations Educational, Scientific and Cultural Organization, Paris, France, 1979.
- Khalifa, H.E., Elhadidi, B., and Dannenhoffer, J.F. (2007), “Efficient Coupling of Multizone and CFD Indoor Flow Models through Proper Orthogonal Decomposition,” LB-07-31, *ASHRAE Transactions*, **113** (Part 2), July 2007, pp. 282–289.
- Kidde Fire Protection (2003), “FM-200 Fire Extinguishing Agent,” Kidde Fire Protection, Oxfordshire, United Kingdom, 2003.
- Kim, A., Crampton, G., and Kanabus-Kaminska, M. (2003), “Corrosion Effect on Hydrogen Fluoride (HF) on Electronic Components,” *Proceedings of Fire Suppression and Detection Research Application Symposium*, Orlando, FL, January 22–24, 2003.
- Marchetti, L. (2003), “Protection and Prevention Principles in the Field of Cultural Heritage,” Monuments and Fine Arts Office, Region Umbria, Perugia, Italy, 2003.

Marmo, L., Fiorentini, L., and Piccinini, N. (2009), "Fire Risk in Historical Buildings. The Case Study of the Arson of a Savoy Residence During Building Restoration Works," *The Proceedings of the Fire and Materials 2009 Conference*, San Francisco, CA, January 26–28, 2009.

Mecklenburg, M.F. (2009), project review correspondence, Smithsonian Conservation Institute, Sept. 22, 2009.

Miser, C.S. et al. (1998), "Measurement of Carbonyl Fluoride, Hydrogen Fluoride, and Other Combustion Byproducts During Fire Suppression Testing by Fourier Transform Infrared Spectroscopy," *Proceedings of Halon Options Technical Working Conference*, Albuquerque, NM, May 12–14, 1998.

Moore, T.A (2000), "Reducing Hydrogen Fluoride and Other Decomposition Using Powders and Halocarbons," *Proceedings of Halon Options Technical Working Conference*, Albuquerque, NM, May 2–4, 2000.

Morris, J. (1991), "Protecting Libraries and Museums from Fire," *Fire Science and Technology*, **11** (1,2), Walnut Creek, CA, 1991, pp. 35–43.

National Fire Protection Association (NFPA) (2005), *Code for the Protection of Cultural Resource Properties – Museums, Libraries and Places of Worship*, NFPA 909, 2005 Edition. Quincy, MA.

National Fire Protection Association (NFPA) (2007a), *Code for Fire Protection of Historic Structures*, NFPA 914, 2007 Edition. Quincy, MA.

National Fire Protection Association (NFPA) (2007b), *Standard for Portable Fire Extinguishers*, NFPA 10, 2007 Edition, Quincy, MA.

National Institute of Building Sciences (2000), "Fire Ratings of Archaic Materials and Assemblies," Washington, DC, 2000.

Nazaroff, W.W. (1989), "Mathematical Modeling and Control of Pollutant Dynamics in Indoor Air," Master Thesis, California Institute of Technology, Pasadena, CA, 1989.

Nazaroff, W.W., Ligocki, M.P., Ma, T., and Cass, G.R. (1990), "Particle Deposition in Museums: Comparison of Modeling and Measurement Results," *Aerosol Science and Technology*, **13** (3), January 1990, pp. 332–348.

Nieuwenhuizen, L. (2005), "Post-Fire Recovery of the Lundy Trophy Collection," retrieved from Museum SOS, http://www.museum-sos.org/docs/strat_post_fire.pdf.

Peatross, M. (1998), "A Review of Thermal Decomposition Product Testing of Halocarbon Fire Suppression Agents," *Proceedings of Halon Options Technical Working Conference*, Albuquerque, NM, May 12–14, 1998.

Pedley, M.D. (1985), "Corrosion of Typical Orbiter Electronic Components Exposed to Halon 1301 Pyrolysis," Products TR-339-001, NASA, White Sands Test Facility, Las Cruces, NM, 1985.

Pyro-Chem (2007), "Pyro-Chem ABC Multipurpose Material Safety Data Sheet," Pyro-Chem, Marinette, WI, October 2007.

Pyro-Chem (2008), "Pyro-Chem Technical Bulletin – Dry Chemical Clean-Up Procedures," Pyro-Chem, Marinette, WI, October 22, 2008.

Roberson, John A. and Crowe, Clayton T. (1975), *Engineering Fluid Mechanics*, Second Edition, Houghton Mifflin Company, Boston, MA, 1975.

Roberts, B. et al. (undated), "An Account of the Conservation and Preservation Procedures Following a Fire at the Huntington Library and Art Gallery," *American Institute for Conservation of Historic and Artistic Works*, <http://www.conservation-us.org/index.cfm?fuseaction=Page.viewPage&pageId=610>.

Rohlf, C. and Favre, J.P. (1991), "Fire Insurance Aspects Regarding Historical Buildings," *Fire Science and Technology*, **11** (1,2), 1991, pp 27–33.

Scoones, K. (1991), "Serious Fires in Libraries and Museums 1986–1991," Fire Protection Association, Morton in Marsh, Gloucestershire, UK, 1991.

Sippola, M.R. and Nazaroff, W.W. (2002a), "Modeling Particle Deposition in Ventilation Ducts," *Proceedings of the 9th International Conference on Indoor Air Quality and Climate (Indoor Air 2002)*, Indoor Air Institute, Monterey, CA, June 30–July 5, 2002, pp. 515–520.

Sippola, M.R. and Nazaroff, W.W. (2002b), "Particle Deposition from Turbulent Flow: Review Of Published Research and Its Applicability to Ventilation Ducts in Commercial Buildings," Lawrence Berkeley National Laboratory Report, LBNL – 51432, June 2002.

Sippola, M.R. and Nazaroff, W.W. (2003), "Modeling Particle Loss in Ventilation Ducts," *Atmospheric Environment*, **37** (39-40), December 2003, pp. 5597–5609.

Stevenson, R.W. (1992), "Big Fire in Windsor Castle Raises Fear about Artwork," retrieved from The New York Times, <http://www.nytimes.com/1992/11/21/world/big-fire-in-windsor-castle-raises-fear-about-artwork.html>.

Su, J.Z. and Kim, A.K. (2002), "Suppression of Pool Fires Using Halocarbon Streaming Agents," *Fire Technology*, **38**, 2002, pp. 7–32.

Tewarson, A., Chu, F., and Hill, J.P. (1992), "Quantification of Fire Characteristics for Assessment of NonThermal Fire Damage," Factory Mutual Research Corporation, Norwood, MA.

Texas Historical Commission (undated), “Basic Guidelines for the Preservation of Historic Artifacts,” retrieved from Texas Historical Commission, Technical Assistance, Austin, TX, <http://www.thc.state.tx.us/museums/musassist.shtml>.

Tien, C.L., Lee, K.Y., and Stretton, A.J. (1988), “Radiation Heat Transfer,” in DiNenno, P.J., Editor in Chief, *The SFPE Handbook of Fire Protection Engineering*, First Edition, National Fire Protection Association, Quincy, MA, 1988.

Underwriters Laboratories Inc. (2005), *Standard for Rating and Testing of Fire Extinguishers*, ANSI/UL 711, Northbrook, IL, 2005 Edition.

Underwriters Laboratories Inc. (2009), *Withdrawal of the Fifth Edition of the Standard for Halogenated Agent Fire Extinguishers, UL 1093 and the Termination of New or Revised UL Listings under the categories of Liquefied Gas-type Extinguishers (GMBY) and Liquefied Gas-type Marine Extinguishers (GPGZ)*, Subject UL 1093, March 12, 2009.

Walton, G.N. and Dols, W.S. (2005), “CONTAM 2.4 User Guide and Program Documentation,” NISTIR 7251, National Institute of Standards and Technology, Gaithersburg, MD, September 2005.

Wang, L. and Chen, Q. (2008), “Applications of a Coupled Multizone-CFD Model to Calculate Airflow and Contaminant Dispersion in Built Environments for Emergency Management,” *HVAC & R Research*, **14** (6), November 2008, pp. 925–939.

Wang, Z. et al. (2007), “Predicting HCl Concentrations in Fire Enclosures using an HCl Decay Model Coupled to a CFD-based Fire Field Model,” *Fire and Materials*, **31** (7), 2007, pp. 443–461.

Wilson, A.J. (1991), “Fire Protection at the Smithsonian Institution,” *Fire Science and Technology*, **11** (1,2), 1991, pp. 45–49.

Woods, C. (undated), “Halon Replacement Comparison at Dorset Record Office,” www.ica.org/groups/sites/default/files/Halon%20replacement.doc

13.0 BIBLIOGRAPHY

Blackman, C., “Choosing Varnishes,” *e_conservation magazine*, Issue **1**, October 2007, <http://www.e-conservationline.com/content/view/568/100>.

Bukowski, R.W., Nuzzolese, V., and Bindo, M., “Performance-Based Fire Protection of Historical Structures,” *Proceedings of Fire Safety in Buildings Forum 2001 Symposium*, Fiameni, C. and Gallina, G., (eds.) Milan, Italy, October 23, 2001, pp. 39–51.

Case Study, “The Lundy Wild Animal Trophy Collection,” (undated), www.museum-sos.org/docs/strat_post_fire.pdf.

Cider, L., “Cleaning and Reliability of Smoke-Contaminated Electronics,” *Fire Technology*, **29** (3), August 1993, pp. 226–245.

Crimm, W. and Stemen, B., “Minimizing Risk: The Bridge Between Wet Collections & Safety,” presentation prepared for American Museum of Natural History, New York, NY, May 15, 2004.

DiNenno, P., Forssell, E., Peatross, M. and Maynard, M., “Evaluation of Alternative Agents for Halon 1301 in Total Flooding Fire Suppression Systems,” *Proceedings of the 1993 Halon Alternatives Technical Working Conference*, Albuquerque, NM, May 11–13, 1993, pp. 161–184.

Ewing, C., Faith, F., Romans, B., Siegmann, C., Ouellette, R., Hughes, T. and Carhart, H., “Extinguishing Class A Fires with Multipurpose Chemicals,” *Fire Technology*, **31** (3), August 1995, pp. 195–211.

Floden, J., Scheil, G. and Klamm, S., “Final Firefighter Exposure Results: A Comparison of Halon 1211, HCFC 123 and PFH,” *Proceedings of the 1993 Halon Alternatives Technical Working Conference*, Albuquerque, NM, May 11–13, 1993, pp. 645–658.

Gimenez, A., Pastor, E., Zarate, L., Planas, E., and Arnaldos, J., “Long-term Forest Fire Retardants: A Review of Quality, Effectiveness, Application and Environmental Considerations,” *International Journal of Wildland Fire*, 2004, **13**, pp. 1–15.

Guha, A. (1997), “A Unified Eulerian Theory of Turbulent Deposition to Smooth and Rough Surfaces,” *Journal of Aerosol Science*, **28** (8), December 1997, pp. 1517–1537.

Guha, A. (2008), “Transport and Deposition of Particles in Turbulent and Laminar Flow,” *Annual Review of Fluid Mechanics*, **40**, January 2008, pp. 311–341.

Haessler, W., “The Extinguishment of Fire,” *Fire Technology*, **10** (4), November 1974, pp. 330–332.

Hoke, S. and Herud, C., “Real-time Analysis of Halon Degradation Products,” NIST Special Publication 984-4, 1993, pp. 185–190.

Huang, X., Wang, X., Jin, X., Liao, G. and Qin, J., “Fire Protection of Heritage Structures: Use of a Portable Water Mist System under High-altitude Conditions,” *Journal of Fire Sciences*, **25** (3), May 2007, pp. 217–239.

Kimmel, E., Smith, E., Reboulet, J., and Carpenter, R., “The Physicochemical Properties of SFE Fire Suppressant Atmospheres in Toxicity vs. Fire Extinguishment Tests: Implications for Aerosol Deposition and Toxicity,” Naval Medical Research Institute Detachment (Toxicology) (NMRI/TD), Washington, DC, November 1997, pp. 143–201.

Lai, A.C.K. and Nazaroff, W.W. (2000), “Modeling Indoor Particle Deposition from Turbulent Flow onto Smooth Surfaces,” *Journal of Aerosol Science*, **31** (4), April 2000, pp. 463–476.

Malhotra, H.L. and Papaioannou, K., “Framework for a CIB Guide on Fire Safety for Historic Buildings,” *Fire Science & Technology*, **11** (1/2) Special Issue for CIB W14 (Fire), 1991, pp. 69–72.

NFPA, "Protecting Our Heritage: A Discourse on Fire Protection and Prevention in Historic Buildings and Landmarks," Second Edition, Jenkins, J. (ed.), NFPA Committee on Libraries, Museums and Historic Buildings, Boston, MA, 1970.

O'Hern, T. and Rader, D., "Practical Application of In Situ Aerosol Measurement," *Proceedings of the 1993 Halon Alternatives Technical Working Conference*, Albuquerque, NM, May 11–13, 1993, pp. 275–286.

Papaioannou, K., "Fire Safety in Historic Buildings and Sites," *Fire Science & Technology*, **11** (1/2) Special Issue for CIB W14 (Fire), 1991, pp. 1–4.

Seebach, J., "The Necessity of Precautionary Fire Protection from the Restorer's Viewpoint," *Fire Science & Technology*, **11** (1/2) Special Issue for CIB W14 (Fire), 1991, pp. 9–12.

Sharma, T., Singh, S., Kumar, S., and Srivastava, A., "An Insight to Museums from Fire Hazards Assessment and Fire Protection Point of View," *Fire Science & Technology*, **11** (1/2) Special Issue for CIB W14 (Fire), 1991, pp. 1–4.

Silverman, R., "Fire and Ice: A Soot Removal Technique Using Dry Ice Blasting," *International Preservation News*, Issue 39, October 2006, pp. 20–24.

Sullivan, B. and Taft, W.H., "Protecting Museum Collections in Storage," *Local History Notebook*, National Park Service, Cincinnati, OH, May/June 1990.

Upham, R., Yuill, G.K., and Bahnfleth, W.P. (1997), "A validation study of the airflow and contaminant migration computer model CONTAM as applied to tall buildings," *ASHRAE Transactions: Symposia*, CI-01-8-2 (RP-903), University Park, Pennsylvania State University, pp. 629–644.

Verdonik, D., Darwin, R. and Williams, F., "U.S. Navy Halon 1211 Replacement Program: Assessment of Aircraft Collateral Damage from Dry Chemical Fire Extinguishing Agents," NRL/MR/6180--99-8417, Naval Research Laboratory, Washington, DC, November 1999.

Watts, Jr., J.M., "Fire Protection Performance Evaluation for Historic Buildings," *Journal of Fire Protection Engineering*, **11** (4), November 2001, pp. 197–208.

Wilson, J., "Assessing Fire Risks and Steps Toward Mitigation," *Museum SOS: Strategies for Emergency Response and Salvage Conference*, American Museum of Natural History (AMNH), New York, NY, May 2004, pp. 1–10.

**APPENDIX A –
EFFECTS OF AMBIENT CONDITIONS, FIRE, AND FIRE EXTINGUISHING
AGENTS ON COLLECTION MATERIAL**

| Materials | Fire Effects | Extinguisher Effects | | | | | | | | | | | | | | |
|-------------------------------|---|--|------------|------------------|-------------------|--|------------------|-------------------|------------|--|-------------------|------------|--|---|--|--|
| | | ABC | | | HCFC Blend B | | | HFC-236fa | | | CO ₂ | | | Water Mist | | |
| | | Physical/Chemical | Mechanical | General Comments | Physical/Chemical | Mechanical | General Comments | Physical/Chemical | Mechanical | General Comments | Physical/Chemical | Mechanical | General Comments | Physical/Chemical | Mechanical | General Comments |
| Architecture | Soot may be driven into stone which could cause indelable stains; fire resistance is a factor for larger, uncontrolled fires. | | | | | | | | | | | | | Potential water staining, with soot/carbon. | Low/moderate impact anticipated | |
| Ethnographic Collections | see also Natural History Collections | | | | | | | | | | | | | | | |
| Glass and Ceramics | Fissures and cracks may occur in marble structures. | | | | | | | | | | | | | | | |
| Leather and Related Materials | Severe deformation and scorching. | No effects where dry powder has not hardened. | | | | | | | | | | | Potential shrinkage and discolorization. | | Stiffening and potential blackening | |
| Metal | Iron - darkening of metal and dark surface corrosion | Long term corrosion, may be difficult to brush off powder. | | | | Corrosion potential | | | | Corrosion potential | | | Potential tamishing. | | Corrosion | |
| Modern Materials | | | | | | | | | | | | | | | | |
| Natural History Collections | Charring of proteinaceous materials; gelatization, desiccation, shrinking of skin from heat; loss of skin; darkening of paint/coloring; grinding of soot into skin. | Dry chem may be difficult to vacuum from hair; grinding potential into skin. | | | | | | | | | | | | | Swelling by hydration; potential expansion and contracting | Dry cleaning is recommended first approach |
| Paintings | Wax/wax coatings will more readily absorb soot/smoke; easel paintings (non-oil) will be much more susceptible to damage; cracking/shrinking of paint. Oil painting canvas deformation, darkening of paint layer and discolorization; layers may bubble/crack. | No effects where dry powder has not hardened; may be hard to remove ABC powder from oil paintings. | | | | | | | | Potential cracking, bubbling, and shrinkage | | | | | | |
| Paper | Paper will char; acid from fire gases (e.g. electrical cable) may effect paper/cellulosic materials. Darkening and deformation of cardboard edges. | No effects where dry powder has not hardened; ABC with moisture may form acid. | | | | | | | | | | | | | cardboard may buckle | |
| Photographic Materials | Photographic emulsions shrink. | | | | | Generally no "neat" effect; may effect reel-to-reel film | | | | Generally no "neat" effect; may effect reel-to-reel film | | | | | | |
| Textiles | Changes in color. Severe shrinkage of wool; scorching; darkening. Potential deleterious effects resulting from fire acid gas. | No effects where dry powder has not hardened; may be hard to brush away powder. | | | | | | | | | | | | | Blotchiness and discoloration | |
| Wood, Furniture and Laquers | Discoloration and bubbling of paint layer; discoloration of tempera by soot. Oil/water gilding (covering/cracking); blooming or whitening due to water/moisture. | No effects where dry powder has not hardened. | | | | | | | | | | | | | Wood with tempera may become blotchy; blooming, whitening; gilding (covering/cracking) | |
| Misc. Materials | | | | | | | | | | | | | | | | |

ABC powder may form a hardened crust on heated and fire involved materials; field data from actual fire incidents indicate that recovery may be problematic and extensive cleaning may be required.

Most materials should remain undamaged; HF and HCl by-product potential in fire situation.

Most materials may remain undamaged; HF by-product potential in a few situations

Most materials may remain undamaged; temperature sensitive materials may be damaged

| Material | General Comments | General Effects | Ideal Conditions | Moisture Effects | | | Light | Temperature Effects | | | Pollutants | | | | |
|---|--|--|---|------------------|-----------|---|---------------------------|---------------------|------|----|--|------|---------------|-----------|--|
| | | | | Susceptible | Resistant | Comments | Visible/UV/IR | Heat | Cold | ΔT | Comments | Dust | Air Pollution | Chemicals | Comments |
| Architecture Brick Clay Tile Concrete Cypress Bark Roof Iron Structure Masonry Metal Work Plaster Stone Terra Cotta Thatched Roof Wood Fiberboard Wooden beams/blanks | Includes architecture, painted, three dimensional objects, sculpture, finely veined marble, polychromy, and architectural decoration. Immobile cultural properties such as buildings, monuments, outdoor sculpture and heritage sites. | | | x | | Stains, rot (wood), stone and other porous materials can get moisture in the surface which can cause cracks and breaking. | Generally least sensitive | | | | | | | | |
| Ethnographic Collections Bark Baskets Costumes Dolls Masks Tools/Weapons | Organic Materials expand and contract in response to fluctuating relative humidity. | | 40-60% RH | x | | | | x | | x | Temperature fluctuation causes expansion and contraction. Heat accelerates aging and deterioration | | | | |
| Glass and Ceramics China (climate insensitive) Crystal Earthenware (porous) Glassware (climate insensitive) Highly fired ceramics Low Fire Earthenware Porcelain Pottery Stable Modern Glass Stained Glass | Can include jewelry. | Crizzled Glass, Grazing, Cracks, Breaking. | 45-60% RH | x | | Fluctuations in humidity can cause salt crystals to dissolve and recrystallize, causing cracking. Prolonged exposure to moisture can cause a cloudy residue on glass. | Least Sensitive | | | x | Rapid changes in temperature can cause cracking. | x | | | Dust can be abrasive |
| Leather and Related Materials Leather | Can be tanned, treated, or coated with a variety of dressings. | | 45-60% RH | x | | Susceptible to shrinkage after being wet. Exposure to water may cause immediate blackening, which is irreversible. | Moderately Sensitive | x | | | New and tanned leather will shrink at 75-80°C. Old leather will shrink at 60-65°C. | | | | |
| Metal Brass Bronze Ferrous Metals Gilded Gold and gold alloys Iron Platinum Silver | Archeological metals are much more prone to damage than newer metal. Candelabra. | | <55% RH <40% for archeological specimens <30% if polished | x | | Corrosion | Least sensitive | | | | | x | x | x | Air pollution and chemicals can directly corrode metals. Dust can accumulate and corrode in the presence of moisture |

| Material | General Comments | General Effects | Ideal Conditions | Moisture Effects | | | Light | Temperature Effects | | | Pollutants | | | | | |
|---|--|--|--------------------------------|------------------|-----------|---|---|---------------------|------|----|------------|--|---------------|-----------|----------|---|
| | | | | Susceptible | Resistant | Comments | Visible/UV/IR | Heat | Cold | ΔT | Comments | Dust | Air Pollution | Chemicals | Comments | |
| Modern Materials Acrylic CDs / DVDs Computers Electronics Magnetic Tape Storage Polyethylene Polypropylene Video Tapes Vinyl Records | Can include materials used to store artifacts or stabilization and restoration materials | | 68F, 20-30% RH (magnetic tape) | | | Electronics and magnetic tape storage can become damaged. Synthetic materials such as nylon, polypropylene and polyethylene are not effected by moisture. | | | | | | | | | | |
| Natural History Collections Anatomical Collections Bones/Fossils/Horns Feathers Fur/Taxidermy Hair Ivory Precious Stones Protein Substances Scrimshaw Skin Parchment and vellum | Includes "wet" collections | Gelatinization, desiccation, shrinkage; see also leather. | Generally 40-60% RH | x | | High humidity and wetting can lead to mold, especially in furs and hairs. Moisture damages organic materials. Can be very sensitive to aqueous materials; swelling by hydration. Parchment and vellum may go translucent upon exposure to water and is exceptionally sensitive to expansion and contraction. | | | | | | | | | | |
| Paintings Acrylic Polymer Varnish Binders of Paint Gesso Low Molecular Weight Resins Murals - In fresco Murals - Fresco secco and tucco | Can be painted on wood, canvas, paper, cardboard, pressed board, artist's board, copper, ivory, glass, plaster, and stone. Gesso - preparation of plater of paris and glue used as a surface for painting. | Pastel, charcoal, malachite pigment, pencil and chalk will smudge. | 40-60% RH (50% is optimal) | x | | Large fluctuations in humidity can cause expansion or contraction of the material, paint can become brittle and crack, curl or loosen. Pigments and dyes may be water soluble. Non-oil paintings more susceptible to damage. | Water color very sensitive. Oils less sensitive. Can cause fading and yellowing. | | x | x | | Low temperature can cause sever damage to paintings and painted surfaces. Paint films will go brittle when subjected to temperatures below their glass transition temperature (-5°C to -10°C for oils, 0°C for alkyds, and 5-10°C for acrylics). Large fluctuations in temperature can cause expansion or contraction of the material, paint can become brittle and crack, curl or loosen. | | | | |
| Paper Archival Papers Books Canvas Bound volumes Cardboard Coated Stock Magazines Maps Oriental Screens Parchment and vellum Stretched Paper | Ink and watercolor on paper. | Coated paper may stick together. Exposure to acidic compounds may hasten the deterioration of paper. Paper and board may distort due to exposure to water or high humidity. buckle. Deposition of soot can mar all surfaces and can become trapped below the surface of porous papers. | <68°F, 30-50% RH | x | | Damp conditions encourage mold growth. Very dry conditions can lead to embrittlement and dessication. Flat paper and bindings must be dried under proper restraint to minimize damage. Damage from water may include localized staining, distortion, breakage due to handling (paper can be very fragile when wet), solubilizing of sizes/coatings, feathering, sinking, or removing of media. Inks may be water soluble. | Some media are very sensitive to light exposure. Deterioration, Discoloring, and Fading | x | x | x | | High temperature accompanied by low RH may dessicate materials. Very cold conditions may cause temporary loss of flexibility. Extreme fluctuations can cause expansion and contraction. | x | x | | Air pollution can degrade paper. Dust and other soils are difficult to safely remove. |

| Material | General Comments | General Effects | Ideal Conditions | Moisture Effects | | | Light | Temperature Effects | | | Pollutants | | | | |
|---|---|--|---|------------------|-----------|--|---|---------------------|------|----|--|------|---------------|-----------|--|
| | | | | Susceptible | Resistant | Comments | Visible/UV/IR | Heat | Cold | ΔT | Comments | Dust | Air Pollution | Chemicals | Comments |
| Photographic Materials Ambrotype Daguerreotype Negatives Photographic Emulsions 35 m Film Reel-to-reel Film | Includes final image material, binder layer, primary support. Image materials include silver, platinum, organic dyes/pigments. Binders include albumen, collodion or gelatin. | | Photographs: 68°F, 30-40% RH, Negatives: 30-40°F, 30-40% RH | x | | High humidity can increase deterioration and promote the growth of mold or mildew; surfaces and break down binders. | Some photographic media are very sensitive. Can cause fading, discoloring | x | | | High temperatures can increase deterioration and promote the growth of mold or mildew, mar surfaces and break down binders | | | | |
| Textiles Cotton Jute Linen Nylon Polyester Silk Wool | Includes Acrylic Polymer Varnish, Starched Clothing, Suspended Clothing, Draperies, Damask, Silk Passementiere | | <80°F, 35-65% RH | x | | Fluctuations can cause expansion and contraction. Painted textiles can crack and peel. Mold and mildew can also form under high humidity. Wet textiles are weaker. Color bleeding may occur. | Very sensitive. Can cause fading, degradation, and permanent damage | x | | x | High temperatures can speed up chemical degradation | x | x | x | Dust and other particulates can be abrasive. Air pollution and chemicals can cause chemical degradation of the textiles. |
| Wood, Furniture, and Laquers | | Wood can emit harmful acids. Blooming or whitening of wax. | 40-60% RH | x | | Changes in humidity can cause expansion and contraction, leading to splitting and cracking. Prolonged exposure to high humidity can cause mold. | Moderately Sensitive. Discoloration, bleeding. | | | | | | | | |
| Misc. Materials Acrylic resin paints Adhesive-saturated felt Film Products Melinex Mylar Plexiglass Polyester batting/film Polyurethane Polyurethane foam Shellac Tyvec Unbleached, undyed muslin Water soluble adhesive gums | | | | | | | | | | | | | | | |

APPENDIX B – TEST SPECIFICATIONS

B1.0 MATERIALS TO BE EXPOSED

Materials to be exposed are subject to sponsor direction. Example materials which may be exposed include:

- Wood - painted
- Iron
- Oil painting
- Leather
- Textiles – wool, cotton, linen
- Cardboard
- Stone/Marble
- Fur/hair
- Glass/ceramic
- CDs/DVDs
- Paper/books
- Water color & acrylic paintings
- Photos/negatives
- Bone/ivory
- Other metals (brass, bronze, Cu, Al, steel)
- Artifacts in display enclosure

Materials shall be conditioned to a temperature of $21 \pm 4^{\circ}\text{C}$ ($70 \pm 8^{\circ}\text{F}$) and a relative humidity of $65 \pm 7\%$ for a minimum of 5 days prior to the exposure test. These materials shall be exposed in the form of 25 x 25 cm (10 x 10 in.) sheets. Materials unable to support themselves shall be mounted/backed with acid free cardboard. The materials shall be pinned with zinc coated nails onto the wall.

Control samples of the materials that are exposed during the fire and non-fire exposure tests shall be conditioned similarly to the exposed samples. These samples shall be sealed in polyethylene bags maintained at the control temperature and packaged for shipping to experts for comparative examination along with the exposed samples.

B2.0 PHYSICAL IMPACT TESTS

B2.1 Tear Potential Tests

During these tests, the extinguisher shall be discharged onto the center of a test material with the desired separation distance from the extinguisher nozzle to the material as illustrated in Figure B-1. The test material is to be rigidly mounted on a 30 x 30 cm (12 x 12 in.) frame constructed of trade 5 x 5 cm (2 x 2 in.) lumber. The frame is then to be attached to the wall of the enclosure at nominally 1.2 m (4 ft) above the floor, the same height as the nozzle of the extinguisher. Tests shall be performed in a wind free, $21 \pm 4^{\circ}\text{C}$ ($70 \pm 8^{\circ}\text{F}$) conditioned enclosure.

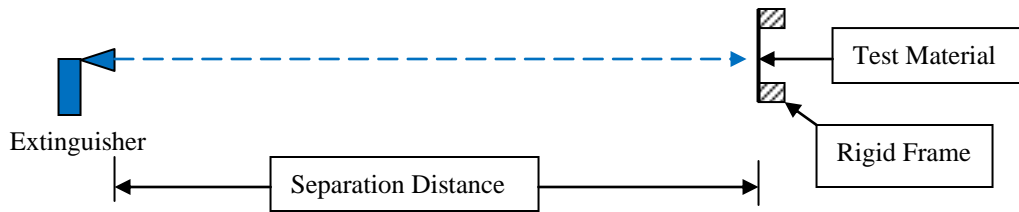

Figure B-1. Tear potential test apparatus

The test materials are: plastic film (.02 to .04 mm (0.8 to 1.5 mil) thickness), aluminum foil (.025 to .04 mm (1 to 1.5 mil) thickness), newsprint (40–50 g/m² (8–10 lb/1,000 ft²) basis weight, and artist canvas (550 g/m² (5 oz/yd²)) pre-primed and stretched.

Two separation distances of 0.9 m (3 ft) and 3.1 m (10 ft) shall be utilized. The carbon dioxide extinguisher range shall be tested at 1.8 m (6 ft).

The portable extinguisher shall be hand held and discharged at center of material. After the discharge of the extinguisher has been completed, the surrogate material shall be checked for tears, cracks, and distortions.

B2.2 Topple Potential Tests

During these tests the extinguisher shall be discharged at the top of a wood block as illustrated in Figure B-2. The block shall be set on end on top of a stand such that the top of the block is nominally 1.2 m (4 ft) above the floor, the same height as the nozzle of the extinguisher. These tests shall be performed inside a wind free, 21 ± 4°C (70 ± 8°F) conditioned enclosure.

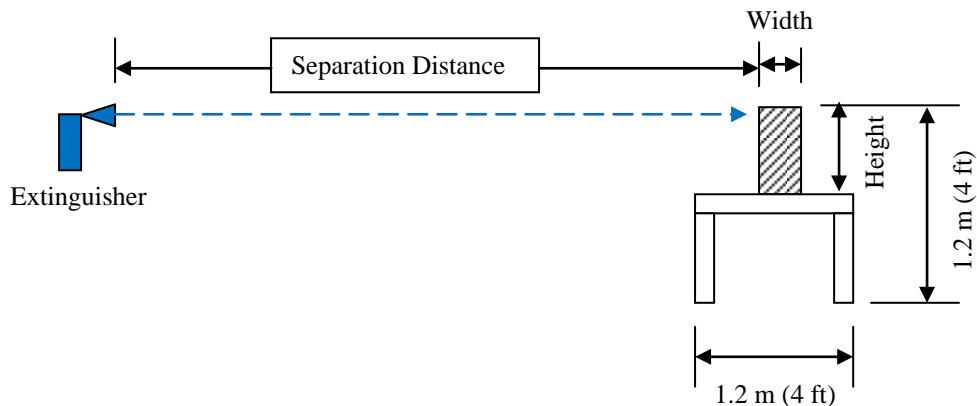

Figure B-2. Topple potential test apparatus

The stand to be used shall provide a smooth, flat, and level surface on which to place the test block. The top surface of the stand, 1.2 x 1.2 m (4 x 4 ft) in dimensions, shall be constructed of unpainted wood without knots or cracks.

The blocks to be used shall be made from white pine with a density of 430 kg/m³ (26.8 lb/ft³) with a tolerance of ±10%. The blocks consist of a series with each block easier to topple than the previous one as given in Table B-1.

Table B-1. Topple Potential Test Objects

| Object | Dimensions with a tolerance of ± 0.5 cm (± 0.2 in.) | | | | | |
|--------------|--|-------|-------|-------|--------|-------|
| | Length | | Width | | Height | |
| | [cm] | [in.] | [cm] | [in.] | [cm] | [in.] |
| Wood Block 1 | 8.9 | 3.5 | 8.9 | 3.5 | 50.0 | 19.7 |
| Wood Block 2 | 3.8 | 1.5 | 8.9 | 3.5 | 50.0 | 19.7 |
| Wood Block 3 | 8.9 | 3.5 | 3.8 | 1.5 | 50.0 | 19.7 |
| Wood Block 4 | 3.8 | 1.5 | 3.8 | 1.5 | 50.0 | 19.7 |

Two separation distances of 0.9 m (3 ft) and 3.1 m (10 ft) shall be utilized. Carbon dioxide extinguishers shall be tested at a range of 1.8 m (6 ft).

The block shall be placed in the center of the stand with the length of the block perpendicular to the direction of flow from the extinguisher. The extinguisher is to be hand held and discharged at the top of the block from the desired separation distance. Any movement (sliding or toppling) of the block shall be noted.

B2.3 Impact Force and Pressure Measurement (Optional)

A target plate, mounted on load cell, shall be utilized to measure the force exerted by the extinguisher jet and a forward looking infrared camera (FLIR) shall be utilized to measure the diameter of the extinguisher just upstream of the target plate. This apparatus is shown schematically in Figure B-3. The load cell shall be mounted on the wall of the enclosure at a height of 1.2 m (4 ft) above the floor, the same elevation of the nozzle of the portable extinguisher. The tests shall be performed inside a wind-free, $21 \pm 4^\circ\text{C}$ ($70 \pm 8^\circ\text{F}$) conditioned enclosure.

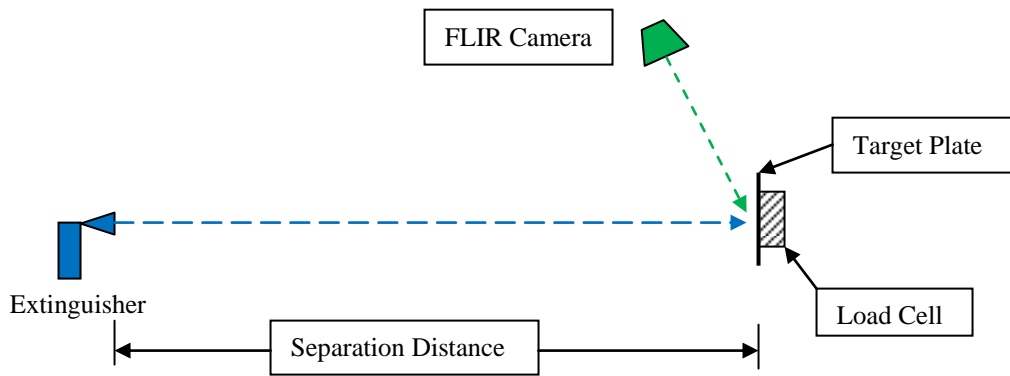

Figure B-3. Physical impact direct measurement apparatus

The load cell shall have a nominal full scale range of 0 to 22 N (0 to 5 lbf) with an accuracy of $\pm 1\%$ full scale.

Two separation distances of 0.9 m (3 ft) and 3.1 m (10 ft) shall be utilized. Carbon dioxide extinguishers shall be tested at a range of 1.8m (6 ft).

The extinguisher shall be discharged onto the center of the target plate. The images from the FLIR shall be analyzed to determine the diameter of the nozzle jet just upstream of the target plate. The determined impact area shall be used with the force measurements from the load cell to determine the pressure exerted by the nozzle jet on the target plate.

B3.0 NON-FIRE EXPOSURE TESTS

During these tests, the portable extinguisher shall be discharged onto the test materials from a distance representing the nominal effective range of the extinguisher. A second set of representative materials shall be indirectly exposed. This second set of materials shall be mounted outside of the extinguisher spray pattern to assess the effects of this reduced exposure on these materials.

The apparatus for these tests is shown schematically in Figure B-4. The representative materials shall be exposed in arrays of 4 materials each.

B3.1 Non-Fire Exposure Test Parameters

The separation distance from extinguisher nozzle outlet to the directly exposed object array shall be within the effective range of the extinguisher but no closer than 3.1 m (10 ft). Carbon dioxide extinguishers shall be no closer than 1.8 m (6 ft). ABC extinguishers shall have a minimum monoammonium phosphate (MAP) content of 85 percent. Other lower concentration ABC extinguishers may also be tested. The manufacturers stated MAP content shall be recorded and documented.

The off-set distance that the indirectly exposed object array is behind and off-set from center-line of extinguisher outlet shall be 1.5 m (4.5 ft).

The directly and indirectly exposed objects shall be mounted on the enclosure walls in a vertical orientation. A smooth target (glass, ceramic, or stainless steel) may be centered in the target array to provide a clean standard for wipe sample analysis.

The indirectly and directly exposed object arrays shall be centered on the same elevation of the portable extinguisher nozzle outlet. This height shall be nominally 1.2 m (4 ft) above floor. The nozzle elevation and angle may be adjusted as determined in pre-test scoping so that the agent discharge impacts the center of the array. Any adjustments shall be documented in the test report.

B3.2 Non-Fire Exposure Apparatus

The objects to be directly exposed to the extinguisher discharge shall be mounted on the back wall of the enclosure. The objects to be indirectly exposed to the extinguisher discharge shall be mounted on the side wall of the enclosure.

These tests shall be performed in an enclosure with a volume of 300 m³ (10,600 ft³) and a minimum 3 m (10 ft) ceiling height. There shall be no active ventilation during the test.

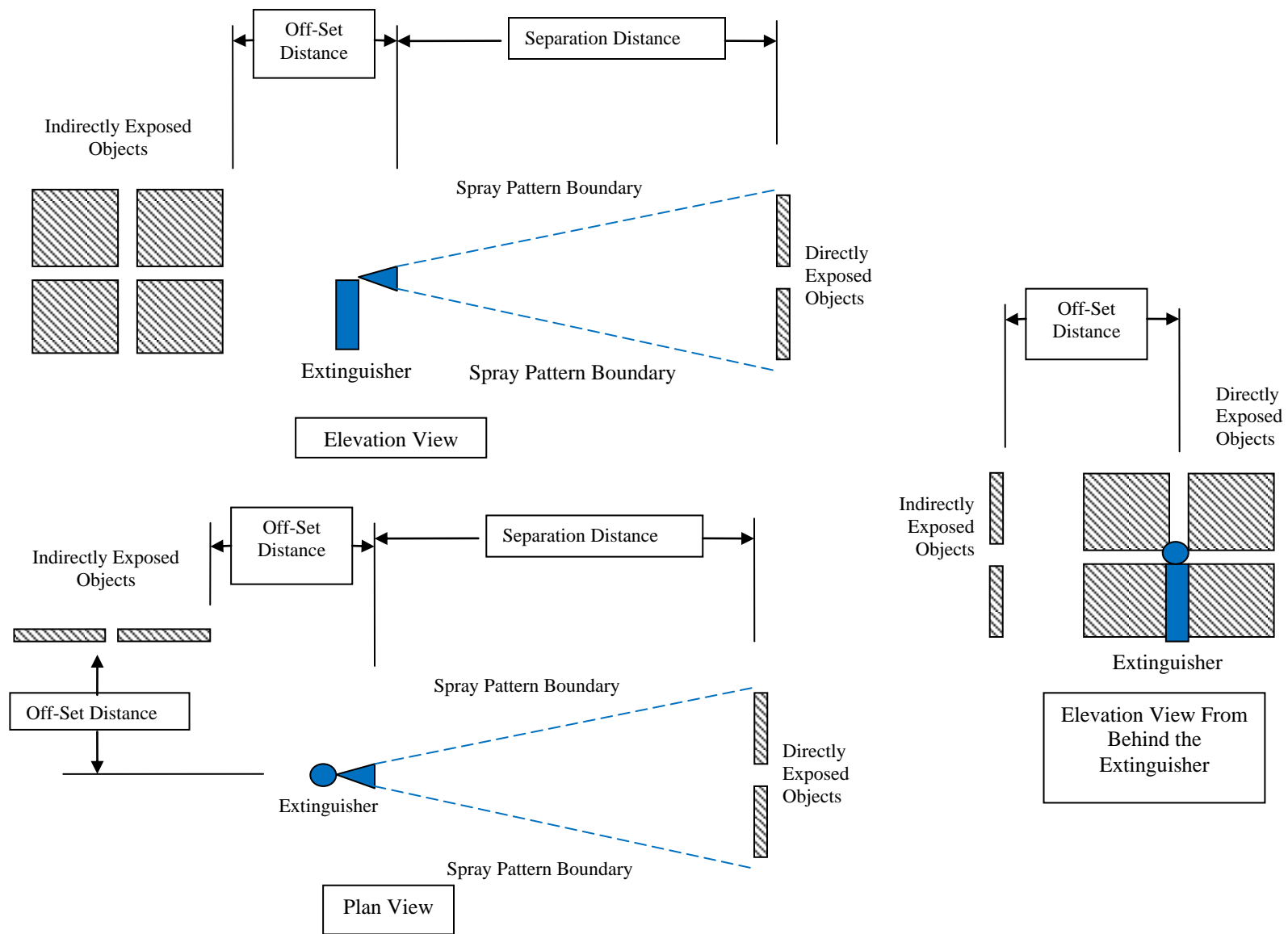

Figure B-4. Non fire exposure apparatus schematic

The instrumentation to be employed during these tests includes a scale to measure the agent deposition on to the exposed objects. The deposition shall not be monitored during exposure but shall be determined by weighing the objects both before and after the exposure.

The temperature and relative humidity shall be monitored outside of extinguisher spray. This shall be accomplished with a vertical tree of five, evenly spaced thermocouples installed 0.45 m (1.5 ft) from the center of indirectly exposed object array. A relative humidity sensor shall be installed at mid-height in the thermocouple tree. A similar thermocouple tree and humidity sensor shall be installed 0.45 m (1.5 ft) from the center of directly exposed object array.

A thermocouple shall be installed in the center of the directly exposed object array. The thermocouple shall be installed from behind the wall.

Optionally, the agent concentration in front of the directly and indirectly exposed objects may be measured. For infrared active agents (Halotron I or FE-36), this measurement may be accomplished with FTIRs configured with its open path in front of the exposed object array. If the FTIR analysis is used, the background readings and spectrums used for analysis shall be electronically stored and provided as part of the test report. For carbon dioxide or other agents for which specific analyzers exist, the analyzer can be configured to draw the gas sample for analysis from the center of the exposed object arrays. For powder-based agents (ABC powder or PKP), the agent concentration measurement may be accomplished with optical density meters configured with the measurement path in front of the exposed object arrays.

The configuration of the instrumentation around the directly and indirectly exposed object arrays is shown schematically in Figure B-5.

B3.3 Non-Fire Exposure Test Procedure

Prior to the start of the start of the test, the enclosure shall be conditioned to a temperature of $21 \pm 4^{\circ}\text{C}$ ($70 \pm 8^{\circ}\text{F}$) and a relative humidity of $65 \pm 7\%$. The temperature shall be the average of the string thermocouples. Extinguishers shall be charged in accordance with manufacturer's specifications. The representative materials shall then be labeled, weighed and mounted in either the directly exposed object array or in the indirectly exposed object array. The background for the FTIR shall be obtained, if it is to be utilized for this test.

The data acquisition system shall be activated. After 30 seconds of background, the extinguisher shall be discharged onto the center of the directly exposed object array from the desired separation distance. At the conclusion of the extinguisher discharge, the data acquisition system shall be secured. The test procedure shall be repeated until all materials are tested.

The exposed objects from both arrays shall be removed from the enclosure and weighed. The objects shall then be visually examined for any sign of damage due to the exposure. This examination shall include checks for tears, cracks, distortions, residue, and discolorations. The objects shall then be placed in a conditioned space (temperature of $21 \pm 4^{\circ}\text{C}$ ($70 \pm 8^{\circ}\text{F}$) and a relative humidity of $65 \pm 7\%$) and allowed to dry for up to 24 hours.

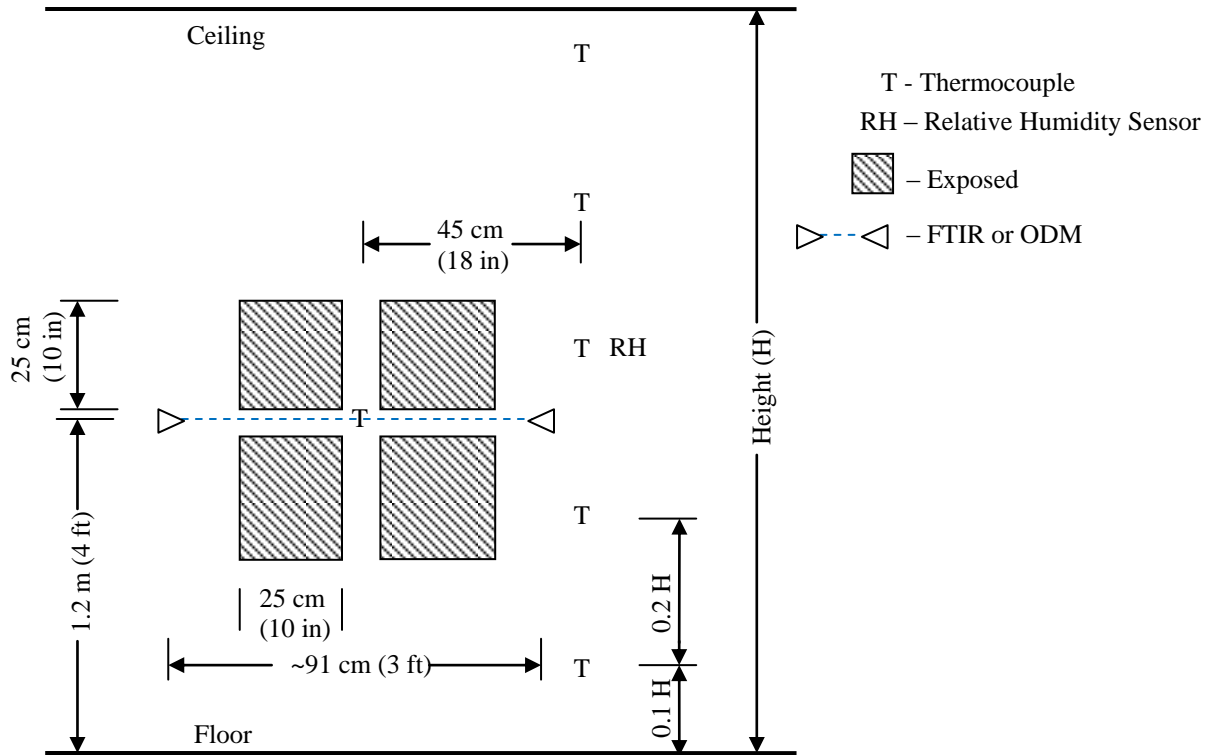

Figure B-5. Instrumentation configuration around the exposed object arrays – Elevation View

The objects shall be subsequently examined for long-term exposure damage based on a predetermined schedule. The objects shall be sealed in polyethylene bags and packaged for shipping to experts for this long term exposure examination. If subsequent tests are to be made in the test enclosure, it shall be ventilated and cleaned to restore it to the required temperature and humidity conditions

B4.0 FIRE EXPOSURE TESTS

During these tests, the portable extinguisher shall be utilized to extinguish a wood crib fire with the representative materials mounted nominally downstream of the wood crib. A second set of representative materials shall be located outside of the direction of discharge of the portable extinguisher. This second set of materials shall be mounted outside of the extinguisher spray pattern to assess the effects of this reduced exposure on these materials.

The apparatus for these tests is shown schematically in Figure B-6. The representative materials shall be exposed in arrays of 4 materials each, similarly to the arrangement utilized during the non-fire tests.

ABC extinguishers shall have a minimum monoammonium phosphate (MAP) content of 85 percent. Other lower concentration ABC extinguishers may be also tested. The manufacturers stated MAP content shall be recorded and documented.

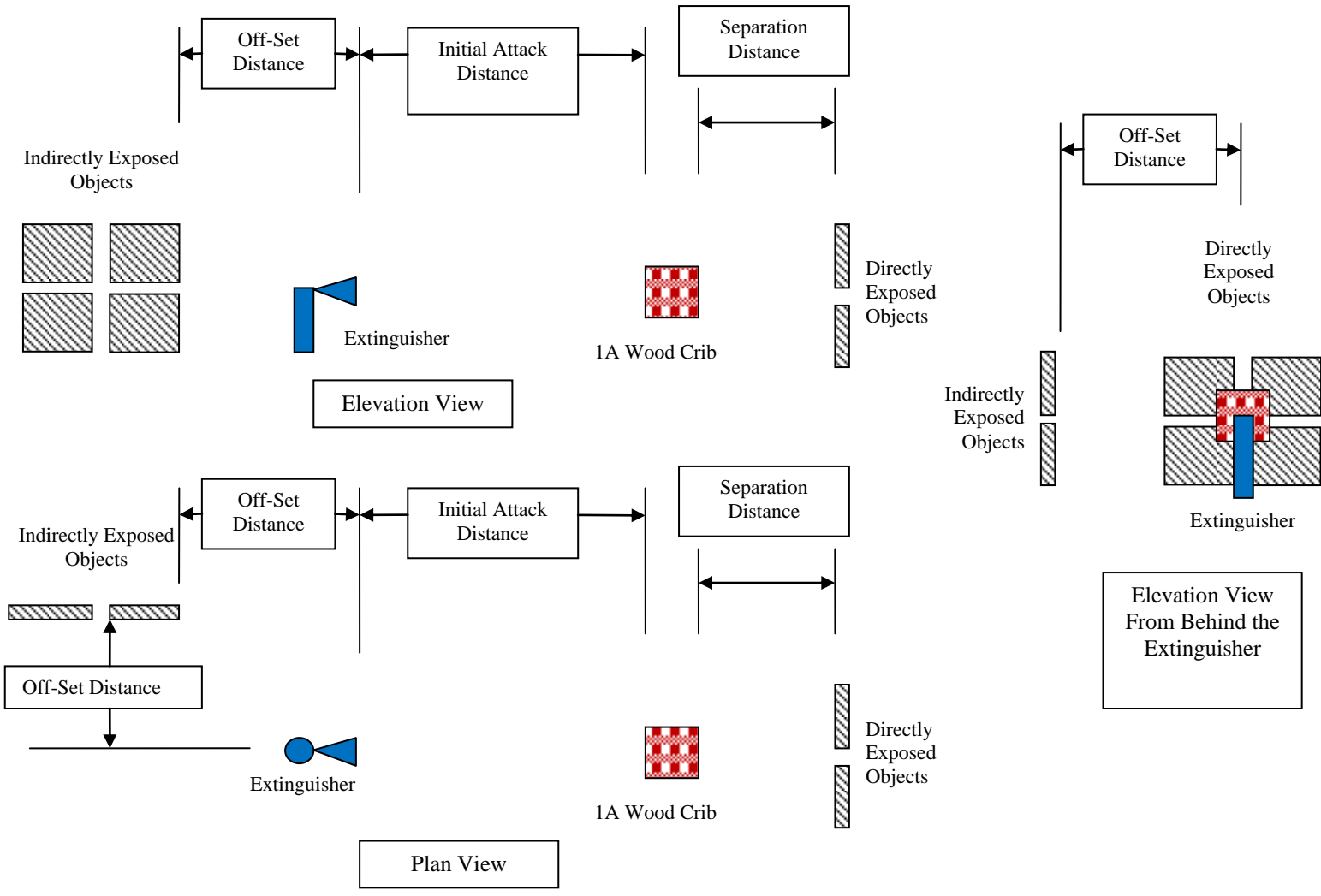

Figure B-6. Fire exposure apparatus schematic

B4.1 Fire Exposure Test Parameters

The separation distance from wood crib fire to the directly exposed object array shall be 2.25 m (7.4 ft).

The initial fire fighter attack distance is 3.7 m (12 ft) representative of the effective range of the portable extinguisher.

The off-set distance that the indirectly exposed object array is behind and off-set from centerline of extinguisher outlet shall be 1.5 m (4.5 ft).

The directly and indirectly exposed objects shall be mounted on the enclosure walls in a vertical orientation. A smooth target (glass, ceramic, or stainless steel) may be centered in the target array to provide a clean standard for wipe sample analysis.

The indirectly and directly exposed object arrays shall be center on the same elevation of the portable extinguisher nozzle outlet and the wood crib. This height shall be nominally 1.2 m (4 ft) above floor. The nozzle elevation and angle may be adjusted as determined in pre-test scoping so that the agent discharge impacts the center of the array. Any adjustments shall be documented in the test report.

B4.2 Fire Exposure Apparatus

The apparatus to be utilized consists of two sets of representative material/object mounts for direct exposure and in direct exposure. The objects to be directly exposed to the extinguisher discharge and fire shall be mounted on the back wall of the enclosure. The objects to be indirectly exposed to the extinguisher discharge and fire shall be mounted on the side wall of the enclosure.

These tests shall be performed in an enclosure with a volume of 300 m³ (10,600 ft³) and a minimum 3 m (10 ft) ceiling height. There shall be no active ventilation during the test.

The modified UL 1-A wood crib shall be raised off the floor 0.9 m (3 ft), such that the centerline of the crib is aligned with the center of the array of materials to be directly exposed. The crib is to be constructed of 12 layers of 6 members each. Each member is to be trade 3.8 x 3.8 x 50 cm (2 x 2 x 20 in.) kiln dried spruce or fir with a moisture content between 9 and 13%. The wood crib is to be ignited with a square 40 x 40 x 10 cm (16 x 16 x 4 in.) pan filled with 350 ml (0.09 gal) of n-heptane. The pan is to be centered 40 cm (16 in.) below the crib.

The instrumentation to be employed during these tests includes a scale to measure the agent deposition on to the exposed objects. The deposition shall not be monitored during exposure but shall be determined by weighing the objects both before and after the exposure.

The temperature and relative humidity monitored outside of extinguisher spray. This shall be accomplished with a vertical tree of five, evenly spaced thermocouples installed 0.45 m (1.5 ft) from the center of indirectly exposed object array. A relative humidity sensor shall be installed at mid-height in the thermocouple tree. A similar thermocouple tree and humidity sensor shall be installed 0.45 m (1.5 ft) from the center of directly exposed object array.

A thermocouple shall be installed in the center of the directly exposed object array. The thermocouple shall be installed from behind the wall such that the thermocouple wire does not affect the flow of the agent.

Optionally, the agent concentration may be monitored in front of both the directly and indirectly exposed object arrays by an appropriate means. For infrared active agents (Halotron I or FE-36), this measurement may be accomplished with FTIRs configured with its open path in front of the exposed object array. If the FTIR analysis is used, the background readings and spectrums used for analysis shall be electronically stored and provided as part of the test report. For other agents for which specific analyzers exist, the analyzer can be configured to draw the gas sample for analysis from the center of the exposed object arrays. For powder based agents (ABC powder or PKP), the agent concentration measurement may be accomplished with optical density meters (ODM), configured with the measurement path in front of the exposed object arrays.

An open path FTIR with its active beam in front of the directly exposed objects shall be used to monitor the thermal decomposition product concentrations (HF, COF₂, HCl), if applicable to the agent utilized.

Wipe samples shall be taken from the enclosure wall near the directly exposed material array. The samples shall be analyzed utilizing an ion specific electrode technique. The samples obtained shall be analyzed for fluoride, chloride and pH.

The configuration of the instrumentation for the directly and indirectly exposed object arrays is shown schematically in Figure B-5.

B4.3 Fire Exposure Test Procedure

Prior to the start of the test, the enclosure shall be conditioned to a temperature of $21 \pm 4^{\circ}\text{C}$ ($70 \pm 8^{\circ}\text{F}$) and a relative humidity of $65 \pm 7\%$. The temperature shall be the average of the string thermocouples. Extinguishers shall be charged in accordance with manufacturer's specifications. The representative materials shall then be labeled, weighed and mounted in both the directly exposed object array or in the indirectly exposed object array. The background for the FTIR shall be obtained. The wood crib shall be placed in its stand above the ignition pan. The pan shall then be filled with 350 ml (12 oz) of n-heptane.

The data acquisition system shall be activated. After 30 seconds of background, the ignition pan beneath the wood crib shall be lit. The n-heptane charge shall burn for approximately 1 min. The crib shall be allowed to burn for three minutes total (including the burn duration of the n-heptane). The fire-fighter shall then begin to suppress the fire with the portable extinguisher, starting from 3.7 m (12 ft) in front of the crib, aligned with the directly exposed material array. The fire-fighter may advance on the crib and move toward either side of the crib as necessary to cause extinguishment. The fire-fighter may not attack the crib from behind (nearest the directly exposed array). At the extinguishment of the crib or the conclusion of the extinguisher discharge, whichever occurs first, the data acquisition system shall be secured. The wipe samples from the walls near the directly exposed array shall then be obtained. The test procedure shall be repeated until all materials are tested.

The exposed objects from both arrays shall then be removed from the enclosure and weighed. The objects shall then be visually examined for any sign of damage due to the exposure. This examination shall include checks for tears, cracks, distortions, residue, and discolorations. The objects shall then be placed in a conditioned space (temperature of $21 \pm 4^{\circ}\text{C}$ ($70 \pm 8^{\circ}\text{F}$) and a relative humidity of $65 \pm 7\%$) and allowed to dry for 24 hours. At a minimum, an assessment shall be made within four hours and 12–24 hours after exposure. The objects shall be subsequently examined for long-term exposure damage based on a predetermined schedule. The objects shall be sealed in polyethylene bags and packaged for shipping to experts for this long term exposure examination. If subsequent tests are to be made in the test enclosure, it shall be ventilated and cleaned to restore it to the required temperature and humidity conditions.