

**Executive Summary
Investigation of Intelligence Activities At Abu Ghraib
pages 1-5.**

**AR 15-6 Investigation of the Abu Ghraib Prison and
205th Military Intelligence Brigade
LTG Anthony R. Jones
pages 6-33**

**AR 15-6 Investigation of the Abu Ghraib Detention
Facility and 205th Military Intelligence Brigade
MG George R. Fay
pages 34-176**

EXECUTIVE SUMMARY

Investigation of Intelligence Activities

At Abu Ghraib

Background

This investigation was ordered initially by LTG Ricardo S. Sanchez, Commander, Combined Joint Task Force Seven (CJTF-7). LTG Sanchez appointed MG George R. Fay as investigating officer under the provisions of Army Regulation 381-10, Procedure 15. MG Fay was appointed to investigate allegations that members of the 205th Military Intelligence Brigade (205 MI BDE) were involved in detainee abuse at the Abu Ghraib Detention Facility. Specifically, MG Fay was to determine whether 205 MI BDE personnel requested, encouraged, condoned, or solicited Military Police (MP) personnel to abuse detainees and whether MI personnel comported with established interrogation procedures and applicable laws and regulations.

On 16 June 2004, Acting Secretary of the Army R. L. Brownlee appointed General Paul J. Kern, Commander, US Army Materiel Command (AMC), as the new Procedure 15 appointing authority. On 25 June 2004, GEN Kern appointed LTG Anthony R. Jones, Deputy Commanding General, US Army Training and Doctrine Command, as an additional Procedure 15 investigating officer. MG Fay was retained as an investigating officer.

Without reinvestigating areas reviewed by MG Fay, LTG Jones was specifically directed to focus on whether organizations or personnel higher than the 205th MI BDE chain of command, or events and circumstances outside of the 205th MI Brigade, were involved, directly or indirectly, in the questionable activities regarding alleged detainee abuse at Abu Ghraib prison.

The investigative teams conducted a comprehensive review of all available background documents and statements pertaining to Abu Ghraib from a wide variety of sources. These sources included the reports written by MG Geoffrey Miller, MG Donald Ryder, MG Antonio Taguba and the Department of Army Inspector General. LTG Jones interviewed LTG Sanchez and MG Barbara Fast, the CJTF-7 Senior Intelligence Staff Officer. MG Fay's team conducted over 170 interviews concerning the interviewees' knowledge of interrogation and detention operations at Abu Ghraib and/or their knowledge of and involvement in detainee abuse. MG Fay's interviews included interviews with MG Fast, MG Walter Wojdakowski, MG Geoffrey Miller, MG Thomas Miller, and BG Janis Karpinski.

Operational Environment

The events at Abu Ghraib cannot be understood in a vacuum. Three interrelated aspects of the operational environment played important roles in the abuses that occurred at Abu Ghraib. First, from the time V Corps transitioned to become CJTF-7, and throughout the period under investigation, it was not resourced adequately to accomplish the missions of the CJTF: stability and support operations (SASO) and support to the Coalition Provisional Authority (CPA). The CJTF-7 headquarters lacked adequate personnel and equipment. In addition, the military police and military intelligence units at Abu Ghraib were severely under-resourced. Second, providing support to the Coalition Provisional Authority (CPA) required greater resources than envisioned in operational plans. Third, operational plans envisioned that CJTF-7 would execute SASO and provide support to the CPA in a relatively non-hostile environment. In fact, opposition was robust and hostilities continued throughout the period under investigation. Therefore, CJTF-7 had to conduct tactical counter-insurgency operations, while also executing its planned missions.

These three circumstances delayed establishment of an intelligence architecture and degraded the ability of the CJTF-7 staff to execute its assigned tasks, including oversight of interrogation and detention operations at Abu Ghraib.

When hostilities were declared over, US forces had control of only 600 Enemy Prisoners of War (EPW) and Iraqi criminals. In the fall of 2003, the number of detainees rose exponentially due to tactical operations to capture counter-insurgents dangerous to U.S. forces and Iraqi civilians. At that time, the CJTF-7 commander believed he had no choice but to use Abu Ghraib as the central detention facility.

Command and staff actions and inaction must be understood in the context of the operational environment discussed above. In light of the operational environment, and CJTF-7 staff and subordinate unit's under-resourcing and increased missions, the CJTF-7 Commander had to prioritize efforts. CJTF-7 devoted its resources to fighting the counter-insurgency and supporting the CPA, thereby saving Coalition and civilian Iraqi lives and assisting in the transition to Iraqi self-rule. In the over-all scheme of OIF, the CJTF-7 Commander and staff performed above expectations.

Abuse

Clearly abuses occurred at the prison at Abu Ghraib. There is no single, simple explanation for why this abuse at Abu Ghraib happened. The primary causes are misconduct (ranging from inhumane to sadistic) by a small group of morally corrupt soldiers and civilians, a lack of discipline on the part of the leaders and Soldiers of the 205th MI BDE and a failure or lack of leadership by multiple echelons within CJTF-7. Contributing factors can be traced to issues affecting Command and Control, Doctrine, Training, and the experience of the Soldiers we asked to perform this vital mission.

For purposes of this report, abuse is defined as treatment of detainees that violated U.S. criminal law or international law or treatment that was inhumane or coercive without lawful justification. Whether the Soldier or contractor knew, at the time of the acts, that the conduct violated any law or standard, is not an element of the definition.

The abuses at Abu Ghraib primarily fall into two categories: a) intentional violent or sexual abuse and, b) abusive actions taken based on misinterpretations or confusion regarding law or policy.

LTG Jones found that while senior level officers did not commit the abuse at Abu Ghraib they did bear responsibility for lack of oversight of the facility, failing to respond in a timely manner to the reports from the International Committee of the Red Cross and for issuing policy memos that failed to provide clear, consistent guidance for execution at the tactical level.

MG Fay has found that from 25 July 2003 to 6 February 2004, twenty-seven 205 MI BDE Personnel allegedly requested, encouraged, condoned or solicited Military Police (MP) personnel to abuse detainees and/or participated in detainee abuse and/or violated established interrogation procedures and applicable laws and regulations during interrogation operations at Abu Ghraib.

Most, though not all, of the violent or sexual abuses occurred separately from scheduled interrogations and did not focus on persons held for intelligence purposes. No policy, directive or doctrine directly or indirectly caused violent or sexual abuse. In these cases, Soldiers knew they were violating the approved techniques and procedures.

Confusion about what interrogation techniques were authorized resulted from the proliferation of guidance and information from other theaters of operation; individual interrogator experiences in other theaters; and, the failure to distinguish between interrogation operations in other theaters and Iraq. This confusion contributed to the occurrence of some of the non-violent and non-sexual abuses.

MG Taguba and MG Fay reviewed the same photographs as supplied by the US Army Criminal Investigation Command (CID). MG Fay identified one additional photograph depicting abuse by MI personnel that had not been previously identified by MG Taguba. MG Fay also identified other abuse that had not been photographed.

Alleged incidents of abuse by military personnel have been referred to the CID for criminal investigation and the chain of command for disciplinary action. Alleged incidents of abuse by civilian contractors have been referred through the Department of Defense to the Department of Justice.

Discipline and Leadership

Military Intelligence and Military Police units had missions throughout the Iraqi Theater of Operations (ITO), however, 205th MI Brigade and 800th Military Police Brigade leaders at Abu Ghraib failed to execute their assigned responsibilities. The leaders from units located at Abu Ghraib or with supervision over Soldiers and units at Abu Ghraib, failed to supervise subordinates or provide direct oversight of this important mission. These leaders failed to properly discipline their Soldiers. These leaders failed to learn from prior mistakes and failed to provide continued mission-specific training. The 205th MI Brigade Commander did not assign a specific subordinate unit to be responsible for interrogations at Abu Ghraib and did not ensure that a Military Intelligence chain of command at Abu Ghraib was established. The absence of effective leadership was a factor in not sooner discovering and taking actions to prevent both the violent/sexual abuse incidents and the misinterpretation/confusion incidents.

Neither Department of Defense nor Army doctrine caused any abuses. Abuses would not have occurred had doctrine been followed and mission training conducted. Nonetheless, certain facets of interrogation and detention operations doctrine need to be updated, refined or expanded, including, the concept, organization, and operations of a Joint Interrogation and Debriefing Center (JIDC); guidance for interrogation techniques at both tactical and strategic levels; the roles, responsibilities and relationships between Military Police and Military Intelligence personnel at detention facilities; and, the establishment and organization of a Joint Task Force structure and, in particular, its intelligence architecture.

Other Contributing Factors

Demands on the Human Intelligence (HUMINT) capabilities in a counter-insurgency and in the future joint operational environment will continue to tax tactical and strategic assets. The Army needs trained and experienced tactical HUMINT personnel.

Working alongside non-DOD organizations/agencies in detention facilities proved complex and demanding. The perception that non-DOD agencies had different rules regarding interrogation and detention operations was evident. Interrogation and detention policies and limits of authority should apply equally to all agencies in the Iraqi Theater of Operations.

"Ghost Detainees"

The appointing authority and investigating officers made a specific finding regarding the issue of "ghost detainees" within Abu Ghraib. It is clear that the interrogation practices of other government agencies led to a loss of accountability at Abu Ghraib. DoD must document and enforce adherence by other government agencies with established DoD practices and procedures while conducting detainee interrogation operations at DoD facilities. This matter requires further investigation and, in accordance

with the provisions of AR 381-10, Part 15, is being referred to the DoD Inspector General, as the DoD liaison with other government agencies for appropriate investigation and evaluation. Soldiers/Sailors/Airmen/Marines should never be put in a position that potentially puts them at risk for non-compliance with the Geneva Convention or Laws of Land Warfare.

Conclusion

Leaders and Soldiers throughout Operation Iraqi Freedom were confronted with a complex and dangerous operational environment. Although a clear breakdown in discipline and leadership, the events at Abu Ghraib should not blind us from the noble conduct of the vast majority of our Soldiers. We are a values based profession in which the clear majority of our Soldiers and leaders take great pride.

A clear vote of confidence should be extended by the senior leadership to the leaders and Soldiers who continue to perform extraordinarily in supporting our Nation's wartime mission. Many of our Soldiers have paid the ultimate sacrifice to preserve the freedoms and liberties that America and our Army represent throughout the world.

23 August 2004

**AR 15-6 Investigation
of the Abu Ghraib Prison
and 205th Military Intelligence Brigade**

LTG Anthony R. Jones

**AR 15-6 Investigation of the
Abu Ghraib Detention Facility
and 205th MI Brigade**

LTG Anthony R. Jones

(U) Table of Contents

1. (U) Executive Summary	3
2. (U) Charter and Investigative Activity	7
3. (U) Background: Operation Iraqi Freedom during this Period	7
4. (U) Operational Environment	8
5. (U) Assessments and Visits to Improve Intelligence, Detention and Interrogation Operations	11
6. (U) Indications and Warnings	12
7. (U) Doctrine, Organizational Structure and Policy Challenges in the Iraqi Theater of Operations	13
8. (U) Specific Comments on Abuse at Abu Ghraib	15
9. (U) Assessments as the Senior Investigating Officer	18
10. (U) Concluding Findings and Recommendations	24

**(U) AR 15-6 Investigation of the
Abu Ghraib Detention Facility
and 205th MI Brigade**

1. (U) Executive Summary

a. (U) Appointment, Charter and Investigative Activity

(1) (U) On 24 June 2004, Acting Secretary of the Army R. L. Brownlee notified me that I was selected to serve as the Senior Investigating Officer in the investigation of the 205th Military Intelligence Brigade. GEN Paul Kern was the appointing authority and in a memorandum, dated 25 June 2004, formally designated me Senior Investigating Officer. MG George Fay, who had been investigating the 205th MI BDE since his appointment by LTG Ricardo Sanchez on 31 March 2004, would continue as an investigating officer. Without reinvestigating areas reviewed by MG Fay, I was specifically directed to focus on whether organizations or personnel higher than the 205th Military Intelligence (MI) Brigade chain of command, or events and circumstances outside of the 205th MI Brigade, were involved, directly or indirectly, in the questionable activities regarding alleged detainee abuse at Abu Ghraib prison.

(2) (U) During the course of my investigation, I interviewed LTG Ricardo Sanchez, the Commander of Combined Joint Task Force-7 (CJTF-7)¹ during the period under investigation, and the senior intelligence officer on his staff, MG Barbara Fast (the "C2"). In addition, I reviewed witness statements that MG Fay's investigation team had collected; assessment and investigation reports written by MG Geoffrey Miller, MG Donald Ryder, MG Antonio Taguba and the Department of the Army Inspector General (DAIG); and other written materials including relevant law, doctrine, organizational documents, policy, directives, and U.S. Central Command (CENTCOM) and CJTF-7 operational orders (OPORDS) and fragmentary orders (FRAGOs).

b. (U) Background and Operational Environment

(1) (U) The events at Abu Ghraib cannot be understood in a vacuum. Three interrelated aspects of the operational environment played important roles in the abuses that occurred at Abu Ghraib. First, from the time V Corps transitioned to become CJTF-7, and throughout the period under investigation, it was not resourced adequately to accomplish the missions of the CJTF: stability and support operations (SASO) and support to the Coalition Provisional Authority (CPA). The CJTF-7 headquarters lacked adequate personnel and equipment. In addition, the military police and military intelligence units at Abu Ghraib were severely under-resourced. Second, providing support to the Coalition Provisional Authority (CPA) required greater resources than envisioned in operational plans. Third, operational plans envisioned that CJTF-7 would execute SASO and provide support to the CPA in a relatively non-hostile environment. In fact, opposition was robust and hostilities continued throughout the period under investigation. Therefore, CJTF-7 had to conduct tactical counter-insurgency operations, while also executing its planned missions.

¹ CJTF-7 was the higher headquarters to which the 205th MI Brigade reported.

(2) (U) These three circumstances delayed establishment of an intelligence architecture and degraded the ability of the CJTF-7 staff to execute its assigned tasks, including oversight of interrogation and detention operations at Abu Ghraib.

(3) (U) When hostilities were declared over, U.S. forces had control of only 600 Enemy Prisoners of War (EPWs) and Iraqi criminals. In the fall of 2003, the number of detainees rose exponentially due to tactical operations to capture counter-insurgents dangerous to U.S. forces and Iraqi civilians. At this time, the CJTF-7 commander believed he had no choice but to use Abu Ghraib as the central detention facility.

c. (U) Abuse at Abu Ghraib

(1) (U) Clearly abuses occurred at the prison at Abu Ghraib. For purposes of this report, I defined abuse as treatment of detainees that violated U.S. criminal law or international law or treatment that was inhumane or coercive without lawful justification. Whether the Soldier or contractor knew, at the time of the acts, that the conduct violated any law or standard, is not an element of the definition. MG Fay's portion of this report describes the particular abuses in detail.

(2) (U) I found that no single, or simple, explanation exists for why some of the Abu Ghraib abuses occurred. For clarity of analysis, my assessment divides abuses at Abu Ghraib into two different types of improper conduct: First, intentional violent or sexual abuses and, second, actions taken based on misinterpretations of or confusion about law or policy.

(3) (U) Intentional violent or sexual abuses include acts causing bodily harm using unlawful force as well as sexual offenses including, but not limited to rape, sodomy and indecent assault. No Soldier or contractor believed that these abuses were permitted by any policy or guidance. If proven, these actions would be criminal acts. The primary causes of the violent and sexual abuses were relatively straight-forward - individual criminal misconduct, clearly in violation of law, policy, and doctrine and contrary to Army values.

(4) (U) Incidents in the second category resulted from misinterpretations of law or policy or resulted from confusion about what interrogation techniques were permitted. These latter abuses include some cases of clothing removal (without any touching) and some uses of dogs in interrogations (uses without physical contact or extreme fear). Some of these incidents may have violated international law. At the time the Soldiers or contractors committed the acts, however, some of them may have honestly believed the techniques were condoned.

d. (U) Major Findings

(1) (U) The chain of command directly above the 205th MI Brigade was not directly involved in the abuses at Abu Ghraib. However, policy memoranda promulgated by the CJTF-7 Commander led indirectly to some of the non-violent and non-sexual abuses. In addition, the CJTF-7 Commander and Deputy Commander failed to ensure proper staff oversight of detention and interrogation operations. Finally, CJTF-7 staff elements reacted inadequately to earlier indications and warnings that problems existed at Abu Ghraib.

Command and staff actions and inaction must be understood in the context of the operational environment discussed above. In light of the operational environment, and CJTF-7 staff and subordinate unit's under-resourcing and increased missions, the CJTF-7 Commander had to prioritize efforts. CJTF-7 devoted its resources to fighting the counter-insurgency and supporting the CPA, thereby saving Coalition and civilian Iraqi lives and assisting in the transition to Iraqi self-rule. I find that the CJTF-7 Commander and staff performed above expectations, in the over-all scheme of OIF.

(2) (U) Most, though not all, of the violent or sexual abuses occurred separately from scheduled interrogations and did not focus on persons held for intelligence purposes. No policy, directive or doctrine directly or indirectly caused violent or sexual abuse. Soldiers knew they were violating the approved techniques and procedures.

(3) (U) Confusion about what interrogation techniques were authorized resulted from the proliferation of guidance and information from other theaters of operation; individual interrogator experiences in other theaters; and, the failure to distinguish between interrogation operations in other theaters and Iraq. This confusion contributed to the occurrence of some of the non-violent and non-sexual abuses.

(4) (U) Military Intelligence and Military Police units also had missions throughout the Iraqi Theater of Operations (ITO), however, 205th MI Brigade and 800th Military Police Brigade leaders at Abu Ghraib failed to execute their assigned responsibilities. The leaders from these units located at Abu Ghraib or with supervision over Soldiers and units at Abu Ghraib, failed to supervise subordinates or provide direct oversight of this important mission. These leaders failed to properly discipline their Soldiers. These leaders failed to learn from prior mistakes and failed to provide continued mission-specific training. The 205th MI Brigade Commander did not assign a specific subordinate unit to be responsible for interrogations at Abu Ghraib and did not ensure that a Military Intelligence chain of command at Abu Ghraib was established. The absence of effective leadership was a factor in not sooner discovering and taking actions to prevent both the violent/sexual abuse incidents and the misinterpretation/confusion incidents.

(5) (U) Neither Defense nor Army doctrine caused any abuses. Abuses would not have occurred had doctrine been followed and mission training conducted. Nonetheless, certain facets of interrogation and detention operations doctrine need to be updated, refined or expanded, including, the concept, organization, and operations of a Joint Interrogation and Debriefing Center (JIDC); guidance for interrogation techniques at both tactical and strategic levels; the roles, responsibilities and relationships between Military Police and Military Intelligence personnel at detention facilities; and, the establishment and organization of a Joint Task Force structure and in particular, its intelligence architecture.

(6) (U) No single or simple theory can explain why some of the abuses at Abu Ghraib occurred. In addition to individual criminal propensities, leadership failures and, multiple policies, many other factors contributed to the abuses occurring at Abu Ghraib, including:

- Safety and security conditions at Abu Ghraib;

- Multiple agencies/organizations involvement in interrogation operations at Abu Ghraib;
- Failure to effectively screen, certify, and then integrate contractor interrogators/analysts/linguists;
- Lack of a clear understanding of MP and MI roles and responsibilities in interrogation operations.
- Dysfunctional command relationships at brigade and higher echelons, including the tactical control (TACON) relationship between the 800th MP Brigade and CJTF-7.

(7) (U) Demands on the Human Intelligence (HUMINT) capabilities in a counter-insurgency and in the future joint operational environment will continue to tax tactical and strategic assets. The Army needs trained and experienced tactical HUMINT personnel.

(8) (U) Working alongside non-DOD organizations/agencies in detention facilities proved complex and demanding. The perception that non-DOD agencies had different rules regarding interrogation and detention operations was evident, Interrogation and detention policies and limits of authority should apply equally to all agencies in the Iraqi Theater of Operations.

(9) (U) Leaders and Soldiers throughout Operation Iraqi Freedom were confronted with a complex and dangerous operational environment. Although a clear breakdown in discipline and leadership, the events at Abu Ghraib should not blind us from the noble conduct of the vast majority of our Soldiers. We are a values based profession in which the clear majority of our Soldiers and leaders take great pride.

(10) (U) A clear vote of confidence should be extended by the senior leadership to the leaders and Soldiers who continue to perform extraordinarily in supporting our Nation's wartime mission. Many of our Soldiers have paid the ultimate sacrifice to preserve the freedoms and liberties that America and our Army represent throughout the world.

2. (U) Charter and Investigative Activity

a. (U) On 24 June 2004, Acting Secretary of the Army, R. L. Brownlee, notified me that I was selected to serve as the Senior Investigating Officer in the investigation of the 205th Military Intelligence Brigade. GEN Paul Kern was the appointing authority and in a memorandum dated 25 June 2004, formally designated me Senior Investigating Officer. MG George Fay, who had been investigating the 205th MI BDE since his appointment by LTG Ricardo Sanchez on 31 March 2004, would continue as an investigating officer.

b. (U) My specific duties were to focus on whether organizations or personnel higher than the 205th Military Intelligence (MI) Brigade chain of command, or events and circumstances outside of the 205th MI Brigade, were involved, directly or indirectly, in the questionable activities regarding alleged detainee abuse at Abu Ghraib prison.

c. (U) In accordance with guidance from the Appointing Authority, I would interview LTG Ricardo Sanchez and other Combined Joint Task Force-7 (CJTF-7) staff, as required, to obtain information to make findings and recommendations to GEN Kern on the culpability of senior leaders who had responsibility for interrogation and detainee operations in Iraq. My directions were to not reinvestigate the areas that MG Fay had already reviewed. Rather, I was to look at operational and strategic level events that occurred prior to and during the period under investigation and determine their relationship, if any, to the abuses that occurred while the 205th MI Brigade was involved in interrogations and intelligence analysis at Abu Ghraib.

d. (U) During the course of my investigation, I interviewed LTG Ricardo Sanchez, the Commander of Combined Joint Task Force-7 (CJTF-7) during the period under investigation, and the senior intelligence officer on his staff, MG Barbara Fast (the "C2"). In addition, I reviewed witness statements that MG Fay's investigation team had collected; reviewed the assessment and investigation reports written by MG Geoffrey Miller, MG Donald Ryder, MG Antonio Taguba, and the Department of the Army Inspector General; and reviewed other written materials including relevant law, doctrine, organizational documents, policy, directives, and U.S. Central Command (CENTCOM) and CJTF-7 Operational Orders (OPORDS) and Fragmentary Orders (FRAGOs).

3. (U) Background: Operation Iraqi Freedom During this Period

4. (U) Operational Environment

a. (U) Before deciding to centralize detainees at Abu Ghraib, major organizational changes were ongoing in the structure of U.S. Forces fighting the Iraqi campaign. Following major ground operations and declaration of the end of hostilities, the U.S. Army V Corps transitioned to become the CJTF-7. Also during this period, then-MG Sanchez was promoted to Lieutenant General and assumed command of V Corps, replacing LTG Wallace who led Phase III, Decisive Operations, in Iraq. LTG Sanchez transitioned from commanding a division, consisting of approximately 15,000 Soldiers, to commanding V Corps. The U.S. Third Army, or ARCENT, was designated the Combined Forces Land Component Command under the U.S. Central Command during the initial phases of OW. When V Corps transitioned to the CJTF-7, the new command assumed responsibility for the Combined Forces Land Component Command (CFLCC) missions and operations in the Iraqi Theater of Operations (IT O). The Forces under the command of LTG Sanchez grew to approximately 180,000 U.S. and Coalition forces. In addition, the new CJTF-7 was directed to transition to Phase IV of the Iraqi campaign. Phase IV operations were envisioned as stability and support operations (SASO) and direct support to the CPA. CJTF-7 assistance to the CPA was essential to help the CPA succeed in recreating essential government departments under the control of Iraqi leaders. CJTF-7 would also help the CPA transition control of critical government organizations, strategic communications, reconstruction contracts, and lines of operation necessary to enable Iraqi self-rule.

b. (U) In actuality, LTG Sanchez and his V Corps staff rapidly realized that the war had not ended. They were in a counter-insurgency operation with a complex, adaptive enemy that opposed the rule of law and ignored the Geneva Conventions. This enemy opposed the transition of the new Iraqi governing councils that would enable self-rule, and opposed any occupation by U.S. or coalition forces. The hostilities continued. Operations were planned and executed to counter the insurgency.

c. (U) In June 2003, when the CJTF-7 organization was established, a vast increase in responsibilities began. A Joint Manning Document (JMD) was developed to delineate the specific skill sets of personnel needed to perform the increased roles and functions of this new headquarters. After multiple reviews, the JMD for the CJTF-7 HQ5 was formally approved for 1400 personnel in December 2003. That JMD included personnel needed to support the Coalition Provisional Authority (CPA), staff the functional elements needed to focus at joint operational and strategic levels, and specifically augment areas such as intelligence, operations, and logistics. Building a coherent, focused team was essential to the success of Phase IV operations.

d. (U) CJTF-7 remained in the direct chain of command of the U.S. Central Command, but also was charged with a direct support role to the CPA. Command relationships of subordinate tactical commands previously under V Corps remained as previously outlined in Operational Orders. Therefore, the divisions' and Corps' separate brigades, which included the 205th MI Brigade, remained under the CJTF-7. The level of authority and responsibilities of a command of this magnitude is normally vested in a four-star level Army Service Component Command under a Regional Combatant Commander. Of the 1400 personnel required on the JMD, the V Corps staff transitioned to only 495, or roughly a third, of the manning requirements. The new JMD also required that key staff positions be manned by general officers rather than the normal

colonel level positions on a Corps staff Although the JMD was properly staffed and approved, personnel and equipment shortages impacted on CJTF-7's ability to execute the mission and remained a critical issue throughout the period in question. The JMD had 169 positions earmarked for support of operations at Abu Ghraib.

(1) (S/NF)

(2) (U) The 800th MP Brigade remained TACON to the CJTF-7 throughout this period. With the essential task and responsibility for all EPW and confinement operations transferring from CFLCC to CJTF-7, this unit would have been more appropriately designated as OPCON instead of TACON to the CJTF. Tactical Control (TACON) allows commanders the detailed and usually local direction and control of movements and maneuver necessary to accomplish missions and tasks. Whereas, Operational Control (OPCON) provides full authority to organize commands and forces and employ them as the commander considers necessary to accomplish assigned missions. The 800th MP Brigade's parent unit in the area of operations remained the 377th Theater Support Command, located in Kuwait. In accordance with the CENTCOM OPLAN, CFLCC (ARCENT) had to provide operational logistic support to Army Forces employed from Kuwait. The TACON relationship of the 800th MP Brigade with CJTF-7 resulted in disparate support from the CJTF-7 staff, lower priority in meeting resource needs for detention facilities, and the lack of intrusive, aggressive oversight of the unit by CJTF-7 leadership. No attempt was made by the CJTF-7 or ARCENT Staff to coordinate a change in this command relationship.

e. (U) Following the period of major ground hostilities in Phase III operations, the infrastructure of the country remained in desperate need of reconstruction. In addition to battle damage, looting, pillaging, and criminal actions had decimated the government buildings and infrastructure necessary to detain enemy prisoners of war or criminals.

f. (U) The logistics system, including local contracted support, to support units in Iraq was slowly catching up to the priority requirements that needed to be executed. Improving living conditions and basic support for Soldiers, as well as ensuring the safety and security of all forces, remained priorities, especially with the advent of the counter-insurgency. Quality of life for Soldiers did not improve in many locations until December of 2003.

g. (U) Prior to the beginning of hostilities, planners estimated 30-100 thousand enemy prisoners of war would need to be secured, segregated, detained, and interrogated. The 800th MP Brigade was given the mission to establish as many as twelve detention centers, to be run by subordinate battalion units. As of May 2003, BG Hill reported that only an estimated 600 detainees were being held - a combination of enemy prisoners and criminals. As a result, additional military police units previously identified for deployment were demobilized in CONUS. The original plan also envisioned that only the prisoners remaining from the initial major combat operations would require detention facilities, and they would eventually be released or turned over to the Iraqi authorities once justice departments and criminal detention facilities were re-established,

h. (U) As major counter-insurgency operations began in the July 2003 timeframe, the demands on the CJTF-7 commander and staff, the CPA, the subordinate units, the Iraqi interim

government, and Soldiers at all levels increased dramatically. Decisions were made to keep some units in-country to fight the insurgency. Pressure increased to obtain operational intelligence on the enemy's identity, support systems, locations, leadership, intelligence sources, weapons and ammunition caches, and centers of gravity. In addition, the location of Saddam Hussein and information on WMD remained intelligence priorities. The complexity of missions being conducted by CJTF-7 and subordinate units increased and placed a high demand on leadership at all levels. Leaders had to adapt to the new environment and prosecute hostilities, while at the same time exercising appropriate compassion for non-combatants and protecting the people who were trying to do what was right for their country. Operations were planned to pursue the various factions of the counter-insurgency based on intelligence developed with the Iraqi people and Coalition Forces. A rapid increase in the number of detainees (due to the apprehension of counter-insurgents who posed a security risk to our Soldiers and to the Iraqi people, members of criminal factions, and personnel of intelligence value) demanded a decision on a detention facility and a need to rapidly expand interrogation operations.

i. (U) Throughout the Iraqi Theater of Operations (ITO), synchronization of force protection and security operations between operational forces and forward operating bases, such as Abu Ghraib, demanded more focus by brigade-level leadership. Supported-to-supporting relationships were blurred due to the large geographical areas given to tactical units. At Abu Ghraib, outside-the-wire responsibilities during the period in question were the responsibility of the 3d Armored Cavalry Regiment and then the 82d Airborne Division. Force Protection and security for the Abu Ghraib forward operating base was an implied task for the 320th MP Battalion initially, and then, after the 19 November FRAGO, a specified task for the 205th MI Brigade Commander. The defense and security of the Abu Ghraib forward operating base, to include engaging the communities outside of the base for information, was a key concern of LTG Sanchez during his visits and led to the decision to place the 205th MI Brigade commander in charge of forces at Abu Ghraib for force protection and defense of the base in November 2003.

j. (U) Interrogating detainees was a massive undertaking. In accordance with doctrine, unit level personnel would gather initial battlefield intelligence at the point of apprehension. Tactical interrogations would continue at designated collection points (CP) at Brigade and Division levels. Then a more detailed interrogation to get operational and strategic intelligence was to be conducted at a designated central detention facility. The location and facility for this detention and interrogation was Abu Ghraib. Abu Ghraib was selected by Ambassador Bremer after consultation with his staff and LTG Sanchez. Abu Ghraib was envisioned as a temporary facility to be used for criminal detainees until the new Iraqi government could be established and an Iraqi prison established at another site. Following operations during the summer of 2003, Abu Ghraib also was designated by CJTF-7 as the detention center for security detainees. The population of criminals, security detainees, and detainees with potential intelligence value grew to an estimated 4000-5000 personnel in the fall of 2003.

k. (U) The 800th MP Brigade was designated the responsible unit for the Abu Ghraib detention facility and for securing and safeguarding the detainees. The 205th MI Brigade was given responsibility for screening and interrogating detainees at Abu Ghraib. The 320th MP battalion was the unit specifically charged with operating the Abu Ghraib detainee facility by the 800th MP Brigade. Initially, the 205th MI Brigade commander did not specify an MI unit or organization for interrogation operations at Abu Ghraib. Interrogators, analysts, and linguists arrived at Abu Ghraib from multiple units and locations within the 205th MI Brigade.

Contractor personnel were also later used to augment interrogation, analyst, and linguist personnel at Abu Ghraib.

5. (U) Assessments and Visits to Improve Intelligence, Detention and Interrogation Operations

a. (U) As commanders at all levels sought operational intelligence, it became apparent that the intelligence structure was undermanned, under-equipped, and inappropriately organized for counter-insurgency operations. Upon arrival in July 2003, MG Barbara Fast was tasked to do an initial assessment of the intelligence architecture needed to execute the CJTF-7 mission in Iraq. Technical intelligence collection means alone were insufficient in providing the requisite information on an enemy that had adapted to the environment and to a high-tech opponent. Only through an aggressive structure of human intelligence (HUMINT) collection and analysis could the requisite information be obtained. Communications equipment, computers, and access to sufficient bandwidth to allow reachback capabilities to national databases were needed to assist in the fusion and collaboration of tactical through strategic intelligence data. Disparate cells of different agencies had to be co-located to allow access to respective data bases to assist in the fusion and collaboration effort. Interrogation reports had to be standardized and rapidly reviewed to allow dissemination to subordinate tactical units, coalition allies, Iraqis, and other personnel at the unclassified level.

b. (U) Following MG Fast's initial assessment and report to CENTCOM headquarters, changes began to take place to put the right architecture in place. An Intelligence Fusion Cell was established, as were a Joint Inter-Agency Task Force and an expanded JC2X HUMINT Management Cell, at CJTF-7 headquarters. The CPA staff was augmented with military personnel from the CJTF-7 intelligence staff. With the assistance of the Department of the Army Staff, CJTF-7 obtained needed communications equipment, computers, and reachback access to the Information Dominance Center (IDC) to collaborate intelligence information. The focus of the previous V Corps staff, which formed the nucleus of the initial CJTF-7 staff, rapidly changed from a tactical focus to a joint operational and strategic level focus. The subsequent successes of this new intelligence architecture created by MG Fast and her team exponentially improved the intelligence process and saved the lives of Coalition Forces and Iraqi civilians. HUMINT operations and the fusion of intelligence led to the capture of key members of the former regime, and ultimately, to the capture of Saddam Hussein himself. During the time period of the Abu Ghraib abuses, the intelligence focus was on Saddam Hussein's capture and exploitation of documents related to Saddam Hussein, preparation for Ramadan, and large scale enemy activity at Fallujah and Najaf. The effort to expand the intelligence organization, obtain operational intelligence about the counter-insurgency, and support the CPA consumed the efforts of the CJTF-7 staff. Responsibilities for oversight of tactical interrogation procedures, Intel analysis, and reporting at Abu Ghraib as throughout the ITO, were entrusted to the commanders in the field.

c. (U) Due to the expanded scope of the mission for this new organization, the need to gain operational intelligence about the counter-insurgency, and the rapid and unexpected number of detainees, assistance was requested to help inform the leadership on proper procedures, techniques, and changes needed for success. The assessment visit by MG Ryder greatly assisted

the review and improvement of detention operations. Ryder's recommendations to automate the in-processing and accountability of detainees using the Biometrics Automated Tool Set (BATS), to discipline the audit trail of detainees from point of capture to the central detention facility, and to properly segregate different groups, were implemented.

d. (S/NF)

e. (U) MG Fast's initial assessment and report on the intelligence organization and the needed systems architecture to support the mission was invaluable to establishing a roadmap for needed intelligence resources. LTG Alexander, the DA G2, was instrumental in providing needed equipment and guidance to improve the intelligence collection and fusion capabilities in Iraq. LTG Alexander was specifically helpful in getting the equipment necessary to support the intelligence architecture from the tactical to the strategic fusion levels.

6. (U) Indications and Warnings

a. (U) In retrospect, indications and warnings had surfaced at the CJTF-7 level that additional oversight and corrective actions were needed in the handling of detainees from point of capture through the central collection facilities, to include Abu Ghraib. Examples of these indications and warnings include: the investigation of an incident at Camp Cropper, the International Committee of the Red Cross (ICRC) reports on handling of detainees in subordinate units, ICRC reports on Abu Ghraib detainee conditions and treatment, CID investigations and disciplinary actions being taken by commanders, the death of an OGA detainee at Abu Ghraib, the lack of an adequate system for identification and accountability of detainees, and division commanders' continual concerns that intelligence information was not returning to the tactical level once detainees were evacuated to the central holding facility. The Commander, CJTF-7, recognized the need to place emphasis on proper handling of detainees and proper treatment of the Iraqi people in close proximity to operations. In October and December 2003, CDR, CJTF-7 published two policy memos entitled "Proper treatment of the Iraqi people during combat operations" and "Dignity and respect while conducting operations." Reports from the assessments of MG Miller and MG Ryder clearly confirmed the CJTF-7 Commander's instincts that action was needed to improve procedures and set the conditions for success in intelligence and detention operations. The report from the CID in January 2004 and subsequent investigation by MG Taguba confirmed that abuses occurred at Abu Ghraib during the period under investigation.

b. (U) I would be remiss if I did not reemphasize that the 180,000 U.S. and coalition forces, under all echelons of command within the CJTF-7, were prosecuting this complex counter-insurgency operation in a tremendously horrid environment, and were performing above all expectations. Leaders and Soldiers confronted a faceless enemy whose hatred of the United States knew no limits. The actions of a few undisciplined Soldiers at Abu Ghraib have overshadowed the selfless service demonstrated every day, twenty-four hours a day, by the vast majority of our Soldiers and civilians on the battlefield. We, as a Nation, owe a debt of gratitude to our service members who have answered our Nation's call and are in harm's way, every day. This fact became perfectly clear to me as I conducted my investigation.

7. (U) Doctrine, Organizational Structure and Policy Challenges in the Iraqi Theater of Operations

a. (U) Doctrine and Organizational Structures

(1) (U) Doctrine could not provide quick solutions for all the situations that confronted CJTF-7. In many cases, the situation, mission, and environment dictated the decisions and the actions taken by the CJTF leadership. This situation is not uncommon. Rarely does war follow the pre-planned strategy. As the V Corps staff morphed to form the nucleus of the CJTF-7 staff, doctrine was not available to prescribe a detailed sequence to efficiently and effectively execute the transition. The new JMD focused on supplementing the V Corps headquarters structure to perform the expected mission in the Iraqi environment - stability and support operations and support of the CPA.

(2) (U) Joint Interrogation and Debriefing Center. In accordance with JP 2.01, the use of a JIDC by a JTF is situation-dependent. No defined organization exists for implementing the JIDC concept. At Abu Ghraib, a JIDC was established based on the recommendation of MG Miller during his assessment. At the time, Abu Ghraib had only a few hundred detainees. LTC Jordan was sent to Abu Ghraib to oversee the establishment of the JIDC. On 19 November 2003, when COL Thomas Pappas assumed the role of commander of the forward operating base, he directed activities of the JIDC and LTC Jordan became the deputy director of the JIDC. There are conflicting statements regarding who had the responsibilities to implement and oversee the JIDC at Abu Ghraib. In accordance with doctrine, the CJTF-7 C2, MG Fast, through her JC2-X staff, provided priority intelligence requirements for the interrogators and analysts in the JIDC. A portion of the approved CJTF-7 JMD earmarked 169 personnel for the interrogation operations and analysis cells in the JIDC. Many of these positions were later filled with contractor personnel. Although a senior officer was directed to be the Chief, JIDC, the establishment and efficient operation of the JIDC was further complicated by the lack of an organizational MI unit and chain of command at Abu Ghraib solely responsible for MI personnel and intelligence operations.

(3) (U) MI & MP Responsibilities at Abu Ghraib The delineation of responsibilities for interrogations between the military intelligence and military police may not have been understood by some Soldiers and some leaders. The doctrinal implications of this issue are discussed later in this report. At Abu Ghraib, the lack of an MI commander and chain of command precluded the coordination needed for effective operations. At the same time, LTC Jordan failed to execute his responsibilities as Chief, JIDC. Tactical doctrine states that interrogators should specify to the guards what types of behavior on their part will facilitate screening of detainees. Normally, interrogation facilities are collocated with detention facilities, requiring close coordination between the MPs who are responsible for detention operations, and the MI personnel who are responsible for screening and interrogations. Both doctrinal manuals, for military police and military intelligence operations, clearly provide that Soldiers and units must obey rules of land warfare and, specifically, the Geneva Conventions when handling detainees. At Abu Ghraib, the delineation of responsibilities seems to have been blurred when military police Soldiers, untrained in interrogation operations, were used to enable interrogations. Problems arose in the following areas: use of dogs in interrogations, sleep deprivation as an interrogation technique and use of isolation as an interrogation technique.

(4) (U) CJTF-7 Staff Responsibility. CJTF-7 responsibility for staff oversight of detention operations, facilities, intelligence analysis and fusion, and limits of authority of interrogation techniques was dispersed among the principal and special staff. Overall responsibility for detention operations was vested in the C3, MG Tom Miller, with further delegation to the Provost Marshal. Support of facilities was a C4 responsibility, with priorities of work established by the DCG, MG Walter Wojdakowski. MG Wojdakowski also had direct responsibility and oversight of the separate brigades assigned or TACON to CJTF-7. Priorities for intelligence collection, analysis and fusion were the responsibility of the C2, MG Fast. Lastly, LTG Sanchez used his Staff Judge Advocate, Colonel Marc Warren, to advise him on the

limits of authority for interrogation and compliance with the Geneva Conventions for the memos published. The lack of one person on the staff to oversee detention operations and facilities, and the responsibilities of all units at a detention facility complicated effective and efficient coordination among the staff Subordinate brigade commanders and their staffs also had to coordinate different actions for support with the various staff sections responsible for the support requested.

b. (U) Policy

(1) (U) Policy Guidance. DOD-wide, formal written policies for interrogation techniques have been prescribed by various levels of command and authority. In most cases, the doctrinal reference is FM 34-52, Intelligence Interrogation, dated September 1992. As stated, this manual is currently under revision by the proponent. During the period under investigation, there was confusing and sometimes conflicting guidance resulting from the number of policy memos and the specific areas of operation the various policies were intended to cover. Each theater's techniques for interrogation and counter-resistance were reviewed by appropriate legal authorities and subjected to external assessments before commanders were advised of their acceptability. In the wartime settings of each theater, commanders were satisfied that appropriate oversight had been conducted for procedures being used for interrogations. However, when reviewing the various reports on the number of abuses in the ITO, it became clear there is no agreed upon definition of abuse among all legal, investigating and oversight agencies.

(2) (U) Interrogation techniques, including Counter-Resistance Techniques, were developed and approved for the detainees in Guantanamo and Afghanistan who were determined not to be EPWs or protected persons under the Geneva Conventions of 1949. The OSD memo promulgated in December 2002, approving techniques and safeguards for interrogation of unlawful combatants in GTMO, included the use of dogs to induce stress and the removal of clothing as Counter-Resistance Techniques. This memo was rescinded in January 2003. A General Counsel Interrogation Working Group was subsequently formed and published a revised memo in April 2003 under the signature of the SECDEF on Counter-Resistance Techniques. This memo produced by the Working Group and the techniques outlined in FM 34-52 were referenced by Colonel Warren and his staff to develop the limits of authority memo for LTG Sanchez. The provisions of Geneva Convention IV, Relative to Protection of Civilian Persons in Time of War, did apply to detainees in Iraq.

(3) (U) Initially, no theater-specific guidance on approved interrogation techniques was published by CJTF-7 for the ITO. Thus, LTG Sanchez reemphasized the limits of authority for

interrogations in his memos dated 14 September 2003 and 12 October 2003. The first was rescinded, and the second addressed only security detainees and, inadvertently, left certain issues for interpretation: namely, the responsibility for clothing detainees, the use of dogs in interrogation, and applicability of techniques to detainees who were not categorized as “security detainees.” Furthermore, some military intelligence personnel executing their interrogation duties at Abu Ghraib had previously served as interrogators in other theaters of operation, primarily Afghanistan and GTMO. These prior interrogation experiences complicated understanding at the interrogator level. The extent of “word of mouth” techniques that were passed to the interrogators in Abu Ghraib by assistance teams from Guantanamo, Fort Huachuca, or amongst themselves due to prior assignments is unclear and likely impossible to definitively determine. The clear thread in the CJTF-7 policy memos and published doctrine is the humane treatment of detainees and the applicability of the Geneva Conventions. Experienced interrogators will confirm that interrogation is an art, not a science, and knowing the limits of authority is crucial. Therefore, the existence of confusing and inconsistent interrogation technique policies contributed to the belief that additional interrogation techniques were condoned in order to gain intelligence.

8. (U) Specific Comments on Abuse at Abu Ghraib

a. (U) This report, so far, has discussed the OPLAN background, operational environment, and policy, doctrine and structural decisions that created conditions which allowed the abuses at Abu Ghraib to occur. The earlier investigations aptly described what happened at Abu Ghraib. MG Taguba found that “numerous incidents of sadistic, blatant, and wanton criminal abuses were inflicted on detainees.” MG Fay identified forty-four incidents of detainee abuse and his report describes the particular abuses in detail. In this section, I rely on the statements and other investigative activity from MG Fay. The conclusions, however, are my own. Clearly, shameful events occurred at the detention facility of Abu Ghraib and the culpable MI and MP Soldiers and leaders should be held responsible. In this section, I set forth an analytical framework for categorizing the abuses propose causes for the incidents of abuse, and also discuss the culpability of organizations and personnel higher than the 205th MI Brigade Commander.

b. (U) For purposes of this report, I defined abuse as treatment of detainees that violated U.S. criminal law (including the Uniform Code of Military Justice (UCMJ)) or international law, or treatment that was inhumane or coercive without lawful justification. Whether the Soldier or contractor knew, at the time of the acts, that the conduct violated any law or standard, is not an element of the definition. In other words, conduct that met the definition would be “abuse” independent of the actor’s knowledge that the conduct violated any law or standard.

c. (U) For clarity of analysis, my assessment divides abuses at Abu Ghraib into two different types of improper conduct: first, intentional violent or sexual abuses and, second, actions taken based on misinterpretation of or confusion about law or policy.

(1) (U) Intentional violent or sexual abuses, for purposes of this report, include acts causing bodily harm using unlawful force as well as sexual offenses including, but not limited to rape, sodomy and indecent assault.² These incidents of physical or sexual abuse are serious

² .As those offenses are defined in the Uniform Code of Military Justice.

enough that no Soldier or contractor believed the conduct was based on official policy or guidance. If proven, these actions would be criminal acts. I found that no policy, directive, or doctrine caused the violent or sexual abuse incidents. Soldiers knew they were violating the approved techniques and procedures. The primary causes of these actions were relatively straight-forward - individual criminal misconduct, clearly in violation of law, policy, and doctrine and contrary to Army values.

(2) (U) The second category of abuse consists of incidents that resulted from misinterpretations of law or policy or resulted from confusion about what interrogation techniques were permitted by law or local SOPs. I found that misinterpretation as to accepted practices or confusion occurred due to the proliferation of guidance and information from other theaters of operation; individual interrogator experiences in other theaters; and, the failure to distinguish between permitted interrogation techniques in other theater environments and Iraq. These abuses include some cases of clothing removal (without any touching), some use of dogs in interrogations (uses without physical contact or extreme fear) and some instances of improper imposition of isolation. Some of these incidents involve conduct which, in retrospect, violated international law. However, at the time some of the Soldiers or contractors committed the acts, they may have honestly believed the techniques were condoned. Some of these incidents either took place during interrogations or were related to interrogation. Often, these incidents consisted of MP Soldiers, rather than MI personnel, implementing interrogation techniques.

d. (U) Some abuses may in fact fall in between these two categories or have elements of both. For instance, some Soldiers under the guise of confusion or misinterpretation may actually have intentionally violated approved interrogation techniques. For example, a Soldier may know that clothing removal is prohibited, but still removed some of a detainee's clothing to try to enhance interrogation techniques. This Soldier can later claim to have believed the actions were condoned. Soldier culpability in this area is best left to individual criminal or command investigations. While no analytical scheme can aptly categorize all misconduct, I think using the two categories set forth above helps explain why the entire range of abuses occurred.

e. (U) The appointment memo directed me to determine whether organizations or personnel higher than the 205th MI Brigade chain of command were involved directly or indirectly, in the questionable activities regarding alleged detainee abuse at Abu Ghraib prison.

(1) (U) I find no organization or individual higher in the chain of command of the 205th MI Brigade were directly involved in the questionable activities regarding alleged detainee abuse at Abu Ghraib prison.

(2) (U) CJTF-7 leaders and staff actions, however, contributed indirectly to the questionable activities regarding alleged detainee abuse at Abu Ghraib.

(a) (U) Policy memoranda promulgated by the CJTF-7 Commander led indirectly to some of the non-violent and non-sexual abuses. The policy memos promulgated at the CJTF-7 level allowed for interpretation in several areas, including use of dogs and removal of clothing. Particularly, in light of the wide spectrum of interrogator qualifications, maturity, and experiences (i.e. in GTMO and Afghanistan), the memos did not adequately set forth the limits on interrogation techniques. Misinterpretations of CJTF policy memos led to some of the abuses at Abu Ghraib, but did not contribute to the violent or sexual abuses.

(b) (U) Inaction at the CJTF-7 staff level may have also contributed to the failure to discover and prevent abuses before January 2004. As discussed above, staff responsibility for detention and interrogation operations was dispersed among the Deputy Commanding General, C2, C3, C4 and SJA. The lack of a single CJTF-7 staff proponent for detention and interrogation operations resulted in no individual staff member focusing on these operations. As discussed in Section V, certain warning signs existed. In addition, there is sufficient evidence to reasonably believe that personnel in the CJTF-7 staff, principally in the OSJA and JC2X had knowledge of potential abuses and misconduct in violation of the Geneva Conventions at Abu Ghraib. This knowledge was not presented to the CJTF-7 leadership. Had the pace of combat operations and support to the CPA not been so overwhelming, the CJTF-7 staff may have provided additional oversight to interrogation operations at Abu Ghraib. The Commander, CJTF-7 had to prioritize efforts and CJTF-7, by necessity, devoted its resources to fighting the counter-insurgency and supporting the CPA, thereby saving U.S. and civilian Iraqi lives and assisting in the transition to Iraqi self-rule. Further, LTG Sanchez and MG Wojdakowski relied upon two senior officer Brigade Commanders (BG Janice Karpinski and COL Pappas) to run detention and interrogation operations at Abu Ghraib. In my professional opinion, in light of all the circumstances, the CJTF-7 staff did everything they could have reasonably been expected to do to successfully complete all their assigned missions.

f. (U) Assessing the materials from MG Fay and from MG Taguba, I agree that leadership failure, at the brigade level and below, clearly was a factor in not sooner discovering and taking actions to prevent both the violent/sexual abuse incidents and the misinterpretation/confusion incidents. At Abu Ghraib, interrogation operations were also plagued by a lack of an organizational chain of command presence and by a lack of proper actions to establish standards and training by the senior leaders present.

(1) (U) The leaders from 205th MI and 800th MP Brigades located at Abu Ghraib or with supervision over Abu Ghraib, failed to supervise subordinates or provide direct oversight of this important mission. The lack of command presence, particularly at night, was clear.

(2) (U) The 205th Brigade Commander did not specifically assign responsibility for interrogation operations to a specific subordinate MI unit at Abu Ghraib and did not ensure that a chain of command for the interrogation operations mission was established at Abu Ghraib. The presence of a clear chain of Military Intelligence command and associated responsibilities would have enhanced effective operations.

(3) (U) The leaders from 205th MI and 800th MP Brigades located at Abu Ghraib or with supervision over Soldiers and units at Abu Ghraib, failed to properly discipline their Soldiers and failed to develop and learn from AARs and lessons learned.

(4) (U) These leaders failed to provide adequate mission-specific training to execute a mission of this magnitude and complexity.

(5) (U) A dysfunctional command relationship existed between the MI Brigade and the MP Brigade, including:

(a) Failure to coordinate and document specific roles and responsibilities;

(b) Confusion at the Soldier level concerning the clarity of the MP role in interrogations.

(6) (U) Despite these leadership deficiencies, the primary cause of the most egregious violent and sexual abuses was the individual criminal propensities of the particular perpetrators. These individuals should not avoid personal responsibility, despite the failings of the chain of command.

g. (U) Other Contributing Factors. No single, or simple, cause explains why some of the Abu Ghraib abuses happened. In addition to the leadership failings discussed above, other contributing factors include:

(1) (U) Safety and security conditions at Abu Ghraib. Resources that might otherwise have been put towards detention operations instead had to be dedicated to force protection. In addition, the difficult circumstances for Soldiers, including a poor quality of life and the constant threat of death or serious injury, contributed to Soldiers' frustrations and increased their levels of stress. Facilities at Abu Ghraib were poor. Working and living conditions created a poor climate to conduct interrogation and detention operations to standard.

(2) (U) The lack of clear and consistent guidance, promulgated at the CJTF level on interrogation procedures coupled with the availability of information on Counter-Resistance Techniques used in other theaters.

(3) (U) Soldier knowledge of interrogation techniques permitted in GTMO and Afghanistan and failure to distinguish between those environments and Iraq.

(4) (U) Interaction with OGA and other agency interrogators who did not follow the same rules as U.S. Forces. There was at least the perception, and perhaps the reality, that non-DOD agencies had different rules regarding interrogation and detention operations. Such a perception encouraged Soldiers to deviate from prescribed techniques.

(5) (U) Integration of some contractors without training, qualifications, and certification created ineffective interrogation teams and the potential for non-compliance with doctrine and applicable laws.

(6) (U) Under-resourcing of personnel in both the 800th MP BDE (including the inability to replace personnel leaving theater) and in the 205th MI Brigade, specifically in the interrogator, analyst, and linguist fields. (Under-resourcing at the CJTF-7 level also contributed and was previously discussed.)

(7) (U) Lack of a clear understanding of MP and MI roles and responsibilities by some Soldiers and leaders.

(8) (U) Lack of clear roles and responsibilities for tactical, as opposed to, strategic interrogation.

9. (U) Assessments as the Senior Investigating Officer

a. (U) Introduction. Due to the previous assessments and investigations conducted on Abu Ghraib, I was able to develop my own assessments based on interviews I conducted, the findings and conclusions in the earlier reports, as well as the materials in MG Fay's report. The following assessments provide insight on the challenges that CJTF-7 faced, as well as areas that need to be addressed by our military in the near future. The specific investigations and assessments were provided by the reports of MG Miller, MG Ryder, MG Taguba, the DAIG, and MG Fay.

b. (U) Charters. MG Miller's and MG Ryder's assessments were conducted on interrogation and detention operations as a result of the request and/or discussions by the CJTF Commander and the Commander, CENTCOM. MG Taguba and MG Fay were directed to investigate personnel in the MP Brigade and the MI Brigade after the discovery of abuses at Abu Ghraib. The DAIG was specifically tasked to conduct an assessment of Detainee Operations as the Army executes its role as DOD Executive Agent for Enemy Prisoners of War and Detention Program.

c. (U) Summaries of assessment visits. The assistance visits by MG Miller and MG Ryder, discussed briefly above, confirmed the instincts of the Commander, CJTF-7, and provided solid recommendations for improving procedures. MG Miller's assessment set forth what had to be done to synchronize intelligence efforts, and provided different techniques in interrogation and analysis. MG Ryder provided processes for more efficient and effective chain of custody of, and accountability for, detainees. MG Taguba's and MG Fay's investigative reports confirmed that abuses occurred and assigned specific responsibility for the actions. The DAIG report provided insights across doctrine, organizations, training, materiel, leadership, personnel and facilities (DOTMLPF) and on capability and standards shortfalls. I found that the assistance visits by senior leaders with experience in detention and interrogation operations, subject matter experts, and mobile training teams were extremely helpful in validating needed procedures and increasing the effectiveness of interrogation and detention operations. The investigative reports and DAIG findings will be used to fix deficiencies that have been found in current operations.

d. (U) Doctrine.

(1) (U) Doctrine is meant to be a guideline to focus efforts in a specific area. Doctrine is the culmination of years of experience, Doctrine allows leaders at all levels to adapt to the different environments and situations that their units may encounter. When prosecuting hostilities, doctrine does not replace the inherent responsibilities of commanders to execute their missions, care for the safety and security of their Soldiers, train their Soldiers and their organizations to be competent and confident in their assigned duties and responsibilities, or uphold the rule of law and legal authority such as the Geneva Convention. An overarching doctrine allows commanders the latitude to develop tactics, techniques, and procedures, as well as unit standard operating procedures, to focus Soldier and unit operations. Commander policies and directives often supplement or emphasize specific items that the commander wants to ensure are clearly understood within their command.

(2) (U) Basic Army and Joint doctrine for detention and interrogation operations served as a guideline for operations in OIF. Doctrine did not cause the abuses at Abu Ghraib. Had Army

doctrine and training been followed, the abuses at Abu Ghraib would not have occurred. Several areas, however, need to be updated, refined or expanded: roles, responsibilities and relationships between MP and MI personnel; the concept, structure, and organization of a JIDC; the transition to and organization of a JTF structure and in particular, the intelligence organization within the JTF headquarters.

(a)(U) Roles, responsibilities and relationships between MP and MI personnel. The various investigations indicate that the delineation of responsibilities for interrogations between the military intelligence and military police may not have been understood by some Soldiers and some leaders. At Abu Ghraib, non-violent and non-sexual abuses may have occurred as a result of confusion in three areas of apparent MI/MP overlap: use of dogs during interrogations, nudity, and implementation of sleep deprivation. Doctrinal manuals prescribe responsibilities for military intelligence and military police personnel at detention facilities. These manuals do not address command or support relationships. Subordinate units of the military intelligence brigade of a Corps are normally tasked with running the Corps Interrogation Facility (CIF). Centralized EPW collection and holding areas, as well as detention centers, are the responsibility of the Military Police with staff oversight by the Provost Marshal. FM 34-52, Intelligence Interrogation, does state that in the screening process of EPWs, MPs and MI Soldiers should coordinate roles.

(b)(U) Relationships between MP and MI personnel and leadership responsibilities at a detention facility of this magnitude need to be more prescriptive. Doctrine establishes the need for coordination and designates detention operations as a military police responsibility. Responsibility for interrogation of detainees remains with the military intelligence community. Doctrine for Interrogation operations states that MPs can enable, in coordination with MI personnel, a more successful interrogation. Exact procedures for how MP Soldiers assist with informing interrogators about detainees or assist with enabling interrogations can be left to interpretation. Our doctrinal manuals are clear on humane treatment of detainees and compliance with the Geneva Conventions by MI, MP and all U.S. Forces. The current version of FM 34-52, Intelligence Interrogation, is under revision to incorporate lessons learned in ongoing theaters of operations. Lessons learned have also resulted in changes to programs of instruction by military police and military intelligence proponents. My assessment is that the ongoing revision of Intelligence Interrogation manuals will assist in clarification of roles and responsibilities. At Abu Ghraib, doctrinal issues did not preclude on-site leaders from taking appropriate action to execute their missions.

(c)(U) The Joint Interrogation and Debriefing Center. The JIDC was formed at Abu Ghraib by personnel from a number of organizations, creating an ad hoc relationship. Further, the establishment of the JIDC at Abu Ghraib, coupled with implementing the new Tiger Team approach to interrogations (where an interrogator, analyst, and linguist operate as a team) were new to Abu Ghraib personnel and demanded creation of a detailed standard operating procedure (SOP). A SOP was initially developed and published in October 2003 by MI personnel at the facility. Joint doctrine needs to expand on the operation and organization for a JIDC at centralized detention facilities. A template for a JIDC needs to be developed, to include identifying Joint and other agency resources with strategic interrogation expertise, to provide insight for combatant commanders in specific areas of operation.

(d)(U) Joint doctrine and policy should also address the roles of military personnel and other agencies in collocated detention and interrogation facilities. All detainees must be in-processed, medically screened, accounted for, and properly documented when interned in a military facility. This did not happen at Abu Ghraib.

(3) (U) Transition to and Organization of JTF Structure and its Intelligence Architecture. The intelligence architecture for the missions tasked to the CJTF-7 was inadequate due to the expanded mission and continuation of hostilities in theater. Several reports stated that lack of manning provided significant challenges due to the increased mission work load and the environment. Certainly, the V Corps Headquarters was not trained, manned or equipped to assume the role of a CJTF. Although the mission was initially considered to be SASO, in fact hostilities continued. CI/HUMINT capabilities in current force structure, among all services, needs a holistic review. The Army has significantly reduced tactical interrogators since Desert Shield/Desert Storm. Creation of the Defense HUMINT Service and worldwide demands for these skills has depleted the number of experienced interrogators that may be needed in the future joint operational environment. The HUMINT management organization within the Intelligence Staff of a JTF needs to be institutionalized and resourced. Specifically, work needs to be done to institutionalize the personnel and equipment needs for future command and control headquarters to include the JIATF and C2X cells within a JTF intelligence staff.

(4) (U) In addition, the ongoing review by the Army and Joint Forces Command to create JTF capable headquarters and Standing Joint Task Force Headquarters organic to combatant commands should be expedited and resourced. Such efforts may have helped transition V Corps to the CJTF-7 staff more rapidly by assigning a Standing Joint Task Force to the CJTF-7. Similarly, the Army's initiative to develop stand alone command and control headquarters, currently known as Units of Employment, that are JTF-capable would have greatly facilitated the transition of the V Corps staff to the new organization.

e. (U) Policy and Procedures

(1) (U) Detention Operations. At first, at Abu Ghraib and elsewhere in Iraq, the handling of detainees, appropriately documenting their capture, and identifying and accounting for them, were all dysfunctional processes, using little or no automation tools. The assistance visits by MG Miller and MG Ryder revealed the need to adhere to established policies and guidance, discipline the process, properly segregate detainees, and use better automation techniques to account for detainees and to provide timely information.

(2) (U) Interrogation Techniques Policy. A review of different theaters' interrogation technique policies reveals the need for clear guidance for interrogation techniques at both the tactical and strategic levels, especially where multiple agencies are involved in interrogation operations. The basic Field Manuals provide guidance for Soldiers conducting interrogations at the tactical level. Different techniques and different authorities currently exist for other agencies. When Army Soldiers and other agency personnel operate in the same areas, guidelines become blurred. The future joint operational environment presents a potential for a mix of lawful and unlawful combatants and a variety of different categories of detainees. Techniques used during initial battlefield interrogations as opposed to at a central detention facility differ in terms of tactical versus more strategic level information collection. The experience, maturity, and source of interrogators at each of these locations may also dictate a change in techniques. In each

theater, commanders were seeking guidance and information on the applicability of the articles of the Geneva Conventions to specific population sets and on what techniques could be used to improve intelligence production and remain within the limits of lawful authorities.

(a)(U) At Abu Ghraib, the lack of consistent policy and command oversight regarding interrogation techniques, coupled with changing policies, contributed to the confusion concerning which techniques could be used, which required higher level approval, and what limits applied to permitted techniques. Initially, CJTF-7 had no theater-specific guidance other than the basic Field Manuals which govern Intelligence Interrogations and Internment and Resettlement operations. Policies for interrogation techniques including policies for Counter-Resistance Techniques, were provided for different theaters of operation—namely Guantanamo, Afghanistan, and Iraq. Some interrogators conducting operations at Abu Ghraib had experience in different theaters and used their experiences to develop procedures at Abu Ghraib. An example of this is the SOP for the JIDC created by personnel of the 519th MI Battalion.

(b)(U) When policies, SOPs, or doctrine were available, Soldiers were inconsistently following them. In addition, in some units, training on standard procedures or mission tasks was inadequate. In my assessment, I do not believe that multiple policies resulted in the violent or sexual abuses discovered at Abu Ghraib. However, confusion over policies contributed to some of the non-violent and non-sexual abuses. There is a need, therefore, to further refine interrogation techniques and limits of authority at the tactical versus the strategic level, and between Soldiers and other agency personnel.

(3) (U) Use of Military Detention Centers by Other Agencies. In joint military detention centers, service members should never be put in a position that potentially puts them at risk for non-compliance with the Geneva Conventions or Laws of Land Warfare. At Abu Ghraib, detainees were accepted from other agencies and services without proper in-processing, accountability, and documentation. These detainees were referred to as “ghost detainees.” Proper procedures must be followed, including, segregating detainees of military intelligence value and properly accounting and caring for detainees incarcerated at military detention centers. The number of ghost detainees temporarily held at Abu Ghraib, and the audit trail of personnel responsible for capturing, medically screening, safeguarding and properly interrogating the “ghost detainees,” cannot be determined.

f. (U) Training. The need for additional training during the mobilization phase or in-country on unit and specific individual tasks was clearly an issue in the reports and assessments. Some military police units found themselves conducting detention operations which was not a normal unit mission essential task, and those units needed additional training to properly accomplish the missions they were given. The collocation and mixture of other agency and civilian personnel conducting detention and interrogation operations became confusing for junior leaders and Soldiers not normally accustomed to working with other organizations. Collective training to standard by MP and MI units in combined scenarios as rigorous as the situations faced in OIF is needed to prepare for the future.

In addition, V Corps personnel, to include commanders and staff, were not trained to execute a JTF mission. The transition from major combat operations to a headquarters focused on SASO and support to the Coalition Provisional Authority was a major transition which the unit did not have time to train or prepare. Most importantly, we must continue to place rigor and

values in our training regimen. Our values are non-negotiable for members of our profession. They are what a professional military force represents to the world. As addressed before, leaders need rigorous training to be able to adapt to this level of complexity.

g. (U) Materiel. Priorities for logistical support remained with the operational units who were conducting combat operations and providing force protection and security of U.S. and coalition forces. Creating an intelligence organization to provide tactical through strategic intelligence in a seamless manner and the dramatic increase in detention operations demanded communications, computers, and a network to support operations. The concept of a Joint Logistics Command should be further examined using lessons learned from OIF/OEF. Automation equipment needed to provide seamless connectivity of intelligence information from tactical through strategic levels, and enable an Intelligence Fusion Center in a JTF should be documented and embedded in JTF capable headquarters. Equipment currently undergoing research and development and commercial off—the-shelf solutions which enable CI/HUMINT operations and enable Soldiers to serve as sensors and collectors should be rapidly pursued. The process of accounting for detainees, their equipment, and their personal property, and documenting their intelligence value, should be automated from the tactical level to the centralized detention facilities.

h. (U) Leader Development. The OIF environment demanded adaptive, confident, and competent leadership at all echelons. Leaders must set the example and be at the critical centers of gravity for their respective operations. Leaders set the example in a values-based profession. The risk to Soldiers and the security of all personnel demanded continued leader involvement in operations, planning, after-action reviews, and clear dissemination of lessons learned, to adapt to the dynamics of the counter-insurgency. Successful leaders were involved in their operations and were at the tip of the spear during critical periods. Leadership failure was seen when leaders did not take charge, failed to provide appropriate guidance, and did not conduct continual training. In some cases, leaders failed to accept responsibility or apply good judgment in executing assigned responsibilities. This latter fact is evident in the lack of a coordinated defense at Abu Ghraib, inconsistent training and standards, and lack of discipline by Soldiers. Commanders and leaders at all levels remain responsible for execution of their mission and the welfare of their Soldiers. In Iraq, leaders had to adapt to a new complex operational environment. Some of our leaders adapted faster than others. We must continue to put rigor in our leader and unit training. Leaders must be trained for certainty and educated for uncertainty. The ability to know how to think rather than what to think is critical in the future Joint Operational Environment. Specific leader and Soldier failures in the 800th MP Brigade and the 205th MI Brigade are identified in the investigative reports by MG Taguba and MG Fay. As discussed above, my review of echelons above brigade revealed that CJTF-7 leaders were not directly involved in the abuses at Abu Ghraib. Their actions and inaction did indirectly contribute to the non-sexual and non-violent abuses.

i. (U) Facilities. Facilities and quality of life for Soldiers and detainees were representative of the conditions throughout the AOR initially. Only when the logistics system became responsive to the needs of units and Soldiers, contracting mechanisms were put in place to support operations, and the transportation system matured to move supplies, were improvements seen in facilities and quality of life. The conditions at Abu Ghraib were representative of the conditions found throughout the country during post Phase III, Decisive Operations. The slow process of developing the logistics system and providing secure lines of

communication directly impeded Soldier security and quality of life.

10. (U) Concluding Findings and Recommendations

a. (U) SUMMARY AS SENIOR INVESTIGATING OFFICER. I derived these findings and recommendations from the observations and assessments discussed in sections 2-9, from the interviews I conducted, and from the documents I have reviewed. Furthermore, I support the recommendations of the Fay and Taguba Reports concerning individual culpability for actions that violated U.S. criminal law (including the Uniform Code of Military Justice (UCMJ)) or international law, or that was inhumane or coercive without lawful justification. The personnel who committed these acts did not act in accordance with the discipline and values that the U.S. Army represents. Leaders who had direct responsibilities for the actions of these individuals failed to adequately exercise their responsibilities in the execution of this mission.

b. (U) RESPONSIBILITY ABOVE 205th MI BRIGADE

(1) (U) Findings:

(a) (U) I find that the chain of command above the 205th MI Brigade was not directly involved in any of the abuses that occurred at Abu Ghraib.

(b) (U) I find that the chain of command above the 205th MI Brigade promulgated policy memoranda that, inadvertently, left room for interpretation and may have indirectly led to some of the non-violent and non-sexual abuse incidents.

(c) (U) I find that LTG Sanchez, and his DCG, MG Wojdakowski, failed to ensure proper staff oversight of detention and interrogation operations. As previously stated, MG Wojdakowski had direct oversight of two new Brigade Commanders. Further, staff elements of the CJTF-7 reacted inadequately to some of the Indications and Warnings discussed above. However, in light of the operational environment, and CJTF-7's under-resourcing and unplanned missions, and the Commander's consistent need to prioritize efforts, I find that the CJTF-7 Commander and staff performed above expectations, in the over-all scheme of OIF.

(d) (U) I find that the TACON relationship of the 800th MP Brigade to the CJTF-7 created a dysfunctional relationship for proper oversight and effective detention operations in the Iraqi Theater of Operations (ff0). In addition, the relationship between leaders and staff of the 205th MI Brigade and 800th MP Brigade was ineffective as they failed to effect proper coordination of roles and responsibilities for detention and interrogation operations.

(e) (U) I find that a number of causes outside of the control of CJTF-7 also contributed to the abuses at Abu Ghraib. These are discussed in Section 8 and include, individuals' criminal propensity; Soldier knowledge of interrogation techniques permitted in GTMO and Afghanistan and failure to distinguish between those environments and Iraq; interaction with OGA and other agency interrogators who did not follow the same rules as U.S. Forces; integration of some contractors without training, qualifications, and certification; under-resourcing of personnel in both the 800th MP BDE (including the inability to replace personnel leaving theater) and in the 205th MI Brigade, specifically in the interrogator, analyst, and linguist fields.

(2) (U) Recommendations:

(a) (U) That CJTF-7 designate a single staff proponent for Detention and Interrogation Operations. The grade of this officer should be commensurate with the level of responsibilities of the particular operation. Further, that the Army in concert with JFCOM should review the concept and clarify responsibilities for a single staff position for Detention and Interrogation operations as part of a JTF capable organization.

(b) (U) That CJTF-7 in concert with CENTCOM publish clear guidance that applies to all units and agencies on roles and responsibilities for Detention and Interrogation Operations, and publish clear guidance on the limits of interrogation authority for interrogation techniques as pertains to the detainee population in the ITO.

(c) (U) That CENTCOM review command relationship and responsibilities for the 800th MP Brigade with CJTF-7 in the conduct of detention operations in the ITO.

(d) (U) That the CJTF-7 Inspector General be designated the staff proponent to rapidly investigate ICRC allegations. That the CJTF-7 Inspector General periodically conduct unscheduled inspections of detention and interrogation operations providing direct feedback to the commander.

c. (U) DOCTRINE

(1) (U) Finding: Army and Joint doctrine did not directly contribute to the abuses found at Abu Ghraib. Abuses would not have occurred had doctrine been followed. Nonetheless, certain areas need to be updated, expanded or refined.

(2) (U) Recommendations:

(a) (U) That JFCOM in concert with the Army update Joint and Army publications to clearly address the concept, organization and operations of a Joint Interrogation and Debriefing Center in a future joint operational environment.

(b) (U) That the Army update interrogation operations doctrine to clarify responsibilities for interrogation techniques at both tactical and strategic levels. The ongoing revision and update of FM 34-52, Intelligence Interrogations, should clarify the roles and responsibilities of MP and MI units at centralized detention facilities.

(c)(U) That DOD assess the impact of current policies on Detention and Interrogation Operations. That DOD review the limits of authority for interrogation techniques and publish guidance that applies to all services and agencies.

d. (U) V CORPS TRANSITION TO CJTF

(1) (U) Findings:

(a)(U) V Corps was never adequately resourced as a CJTF. The challenge of transitioning from V Corps HQ5 to CJTF-7 without adequate personnel, equipment, and intelligence architecture, severely degraded the commander and staff during transition. Personnel shortages documented in the JMD continued to preclude operational capabilities.

(b)(U) Command and control headquarters that can perform as a Joint Task Force in a joint operational environment will be the norm for the future. This fact warrants action by supporting commands and services to resource and train JTF capable headquarters for success.

(2) (U) Recommendations:

(a)(U) That the Army expedite the development and transition of Corps-level command and control headquarters into JTF-capable organizations.

(b)(U) That the Army in concert with JFCOM institutionalize and resource the personnel and equipment needs of future JTF-capable headquarters, including the intelligence architecture of such headquarters.

e. (U) INTELLIGENCE ARCHITECTURE and INTELLIGENCE PERSONNEL RESOURCES

(1) (U) Findings:

(a)(U) Demands on the HUMINT capabilities in a counter-insurgency and in the future joint operational environment will continue to tax tactical and strategic assets. An Intelligence Fusion Center, a Joint Inter-agency Task Force and a JC2X are essential to provide seamless tactical through strategic level intelligence in a JTF headquarters.

(b)(U) Future land forces, especially the Army, need trained and experienced tactical HUMINT personnel to operate in the future Joint Operational Environment,

(2) (U) Recommendations:

(a) (U) That the Army conduct a holistic review of the CIIHUMINT intelligence force structure and prioritize needs for the future joint operational environment. The review should consider the personnel, equipment and resources needed to provide a seamless intelligence capability from the tactical to the strategic level to support the combatant commander.

(b) (U) That the Army align and train HUMINT assets geographically to leverage language skills and knowledge of culture.

(c) (U) That land forces, particularly MI and MP personnel, conduct rigorous collective training to replicate the complex environment experienced in OIF and in likely future areas of conflict.

f. (U) FACILITIES

(1) (U) finding: Abu Ghraib detention facility was inadequate for safe and secure detention and interrogation operations. CJTF-7 lacked viable alternatives due to the depleted infrastructure in Iraq.

(2) (U) Recommendation: That the Army review the concept of detainee contingency facilities that can be rapidly deployed and established to safeguard and secure detainees, while providing necessary facilities to conduct screening and interrogations (similar to the concept of the Force Provider or Red Horse contingency facilities, where pre-fabricated buildings can be set up quickly). Adopting this recommendation would provide commanders an option for rapidly deploying and establishing detention facilities.

g. (U) OTHER GOVERNMENT AGENCIES

(1) (U) Findings:

(a) (U) Working alongside non-military organizations/agencies to jointly execute missions for our Nation, proved to be complex and demanding on military units at the tactical level. There was at least the perception that non-DOD agencies had different rules regarding interrogation and detention operations. Policies and specific limits of authority need review to ensure applicability to all organizations operating in the designated theater of operations

(b) (U) Seamless sharing of operational intelligence was hindered by lack of a fusion center that received, analyzed, and disseminated all intelligence collected by CJTF-7 units and other agencies/units outside of the CJTF-7 chain of command.

(c) (U) Proliferation of Interrogation and Counter-Resistance Technique memorandums, with specific categorization of unlawful combatants in various theaters of operations, and the inter-mingling of tactical, strategic, and other agency interrogators at the central detention facility of Abu Ghraib, provided a permissive and compromising climate for Soldiers.

(d) (U) Soldiers/Sailors/Airmen/Marines should never be put in a position that potentially puts them at risk for non-compliance with the Geneva Conventions or Laws of Land Warfare

(2) (U) Recommendations:

(a)(U) That DOD review inter-agency policies to ensure that all parties in a specific theater of operations are required to adhere to the same guidance and rules in the use of military Interrogation and Detention Facilities, including limits of authority for interrogation techniques.

(b)(U) That CENTCOM publish guidance for compliance by all agencies/organizations utilizing military detention facilities in the Iraqi theater of operation.

(c)(U) That DOD review the responsibilities for interrogations by other agencies and other agencies responsibilities to the combatant commander to provide intelligence information and support.

(d)(U) That DOD assess the impact of current policies and guidance on unlawful combatants in the conduct of Detention and Interrogation Operations. And, that DOD review the limits of authority for use of interrogation techniques and publish guidance that is applicable to all parties using military facilities.

h. (U) LEADERSHIP and SUCCESSES

(1) (U) Findings:

(a) (U) Leaders throughout Operation Iraqi Freedom were confronted with a complex operational environment. The speed at which leaders at all echelons adapted to this environment varied based on level of training, maturity in command, and ability to see the battlefield. The adaptability of leaders in future operational environments will be critical.

(b) (U) In Operation Iraqi Freedom, as the intelligence architecture matured and became properly equipped and organized, and close working relationships with all intelligence agencies and other OIF forces developed, there were clear successes in obtaining intelligence.

(c) (U) HUMINT management and Intelligence Fusion were essential to enable success in this complex operational environment.

(2) (U) Recommendations.

(a) (U) That rigorous leader training in our institutions, at home stations, and at the Army's Training Centers (Joint Readiness Training Center, National Training Center, Combat Maneuver Training Center, and Battle Command Training Program) continue.

(b) (U) That DOD/CENTCOM and the senior leaders of all services recognize and provide a vote of confidence to our military's leaders and Soldiers executing the OIF mission and supporting the Iraqi people.

SECRET//NOFORN//X1

**AR 15-6 INVESTIGATION OF THE
ABU GHRAIB DETENTION FACILITY AND
205th MILITARY INTELLIGENCE BRIGADE (U)**

**MG GEORGE R. FAY
INVESTIGATING OFFICER**

SECRET//NOFORN//X1

~~CLASSIFIED BY: AR 380-6~~
~~DECLASSIFY ON: OADR~~

SUBJECT: (U) AR 15-6 Investigation of the Abu Ghraib Detention Facility and
205th MI Brigade

TABLE OF CONTENTS

1. (U) Appointing Official's Instructions and Investigation Methodology	4
2. (U) Executive Summary	7
3. (U) Background and Environment	10
a. (U) Operational Environment	10
b. (U) Law, Policy, Doctrine and Training	11
(1) (U) Applicable Law	11
(2) (U) Army Regulation 190-8	14
(3) (U) Military Intelligence Doctrine and Training	15
(4) (U) Military Police Doctrine and Training	20
(5) (U) Intelligence and Interrogation Policy Development	21
(6) (U) Other Regulatory Procedural Guidance	29
4. (U) Summary of Events at Abu Ghraib	30
a. (U) Military Intelligence Task Organization and Resources	31
(1) (U) Task Organization	
(2) (U) Resources	
b. (U) Establishment of the Prison at Abu Ghraib	33
c. (U) Detention Operations and Release Procedures	34
d. (U) Establishment of Military Police Presence at Abu Ghraib	39
e. (U) Establishment of Military Intelligence Presence at Abu Ghraib	40
f. (U) Establishment, Organization, and Operation of the Joint Interrogation and Debriefing Center (JIDC)	41
g. (U) Contract Interrogators and Linguists	47
h. (U) Other Government Agencies and Abu Ghraib	52
i. (U) The Move of the 205th Military Intelligence Brigade Commander to Abu Ghraib	55
j. (U) Advisory and Training Team Deployments	57
(1) (U) MG G. Miller Visit	
(2) (U) JTF-GTMO Training Team	
(3) (U) Fort Huachuca Mobile Training Team	
k. (U) International Committee of the Red Cross (ICRC)	64
5. (U) Summary of Abuses at Abu Ghraib	68

SUBJECT: (U) AR 15-6 Investigation of the Abu Ghraib Detention Facility and
205th MI Brigade

TABLE OF CONTENTS (cont)

6. (U) Findings and Recommendations	109
a. (U) Major Findings	109
b. (U) Other Findings and Recommendations	109
c. (U) Individual Responsibility for Detainee Abuse at Abu Ghraib	120
7. (U) Personnel Listing	137
8. (U) Task Force Members	138
9. (U) Acronyms	139

SUBJECT: (U) AR 15-6 Investigation of the Abu Ghraib Detention Facility and
205th MI Brigade

1. (U) Appointing Officials' Instructions and Investigative Methodology

a. (U) Appointing Officials' Instruction.

(1) (U) On 31 March 2004, LTG Ricardo S. Sanchez, Commander, Combined Joint Task Force 7 (CJTF-7), appointed MG George R. Fay as an Army Regulation (AR) 381-10 Procedure 15 Investigating Officer. LTG Sanchez determined, based upon MG Antonio Taguba's out brief of the results of an Article 15-6 investigation of the Abu Ghraib Detention Facility in Iraq, that another investigation was warranted. MG Fay was to investigate allegations that members of the 205th Military Intelligence Brigade were involved in detainee abuse at the Abu Ghraib Detention Facility.

(a) (U) MG Fay was instructed as follows: Pursuant to AR 381-10, Procedure 15, you are hereby appointed as an investigating officer to conduct an investigation in accordance with (IAW) Army Regulation (AR) 15-6 into all the relevant facts and circumstances surrounding the alleged misconduct on the part of personnel assigned and/or attached to the 205th Military Intelligence (MI) Brigade, to include civilian interrogators and/or interpreters, from 15 August 2003 to 1 February 2004 at the Abu Ghraib (AG) Detention Facility.

(b) (U) Specifically, you will investigate the following areas:

[1] (U) Whether 205th MI Brigade personnel requested, encouraged, condoned, or solicited Military Police (MP) personnel to abuse detainees at AG as preparation for interrogation operations.

[2] (U) Whether 205th MI Brigade personnel comported with established interrogation procedures and applicable laws and regulations when questioning Iraqi security internees at the Joint Interrogation and Debriefing Center.

(2) (U) The Commander, United States Central Command (CENTCOM) requested a new appointing authority and investigating officer be assigned to the investigation. On 14 June 2004, Secretary of Defense (SECDEF) Donald Rumsfeld requested the Acting Secretary of the Army (SECARMY) R.L.Brownlee assign an "officer senior to LTG Sanchez" to assume his duties as appointing authority, and a new or additional investigating officer should one be required. SECDEF provided the following additional guidance to the Acting SECARMY:

(U) The new appointing authority shall refer recommendations concerning issues at the Department of the Army level to the Department of the Army and recommendations concerning issues at the Department of Defense (DoD) level to the Department of Defense for appropriate action. The appointing authority shall refer the completed report to the Commander,

SUBJECT: (U) AR 15-6 Investigation of the Abu Ghraib Detention Facility and
205th MI Brigade

United States Central Command for further action as appropriate, including forwarding to the ATSD(IO) [Assistant to the Secretary of Defense for Intelligence Oversight] in accordance with DoD Directive 5240.1-R and CJCS-I 5901.01. Matters concerning accountability, if any, should be referred by the appointing authority, without recommendation, to the appropriate level of the chain of command for disposition.

(3) (U) On 16 June 2004, Acting SECARMY Brownlee designated GEN Paul J. Kern, Commander of the US Army Materiel Command, as the new Procedure 15 appointing authority. Acting SECARMY Brownlee's instructions included the following:

(a) (U) I am designating you as the appointing authority. Major General Fay remains available to perform duties as the investigating officer. If you determine, however, after reviewing the status of the investigation, that a new or additional investigating officer is necessary, please present that request to me.

(b) (U) Upon receipt of the investigation, you will refer all recommendations concerning issues at the Department of the Army level to me and all recommendations concerning issues at the Department of Defense level to the Secretary of Defense for appropriate action. You will refer the completed report to the Commander, United States Central Command, for further action as appropriate, including forwarding to ATSD(IO) IAW DoD Directive 5240.1-R and CJCS-I 5901.01. Finally, you should refer matters concerning accountability, if any, without recommendation, to the appropriate level of the chain of command for disposition. If you determine that you need further legal resources to accomplish this mission, you should contact the Judge Advocate General.

(4) (U) On 25 June 2004, GEN Kern appointed LTG Anthony R. Jones, Deputy Commanding General, US Army Training and Doctrine Command (TRADOC), as an additional Procedure 15 investigating officer. GEN Kern's instructions to LTG Jones included the following:

(a) (U) Pursuant to AR 381-10, Procedure 15, and AR 15-6, you are hereby appointed as an investigating officer to conduct an investigation of alleged misconduct involving personnel assigned or attached to the 205th Military Intelligence Brigade at the Abu Ghraib Detention Facility. Your appointment is as an additional investigating officer. MG Fay and his investigative team are available to assist you.

(b) (U) Specifically, the purpose of the investigation is to determine the facts and to determine whether the questionable activity at Abu Ghraib is legal and is consistent with applicable policy. In LTG Sanchez's 31 March 2004 appointment letter to MG Fay, which I have adopted, he specified three areas into which the investigation was to look: whether the 205th

SUBJECT: (U) AR 15-6 Investigation of the Abu Ghraib Detention Facility and
205th MI Brigade

Military Intelligence Brigade had been involved in Military Police detainee abuse at Abu Ghraib; whether 205th Military Intelligence Brigade personnel complied with established procedures, regulations, and laws when questioning internees at the Joint Interrogation and Debriefing Center; and the facts behind several identified sworn statements. In addition, your investigation should determine whether organizations or personnel higher in the chain of command of the 205th Military Intelligence Brigade were involved directly or indirectly in any questionable activities regarding alleged detainee abuse at Abu Ghraib.

b. (U) Investigative Methodology.

(1) (U) The investigative team conducted a comprehensive and exhaustive review of available background documents and statements pertaining to the operations of the 205th Military Intelligence (MI) Brigade (205 MI BDE) at Abu Ghraib from a wide variety of sources, to include all previous investigations. Where possible, coordination was established with other ongoing investigations of the same nature.

(2) (U) Over 170 personnel were interviewed (some multiple times) during the course of the investigation (Reference Annex B, Appendix 1). These interviews included personnel assigned or attached to the 205 MI BDE, the 800th Military Police (MP) Brigade (800 MP BDE), CJTF-7, Joint Task Force Guantanamo (JTF-GTMO), 28th Combat Support Hospital (CSH), the United States Army Intelligence Center (USAIC), the United States Navy, Titan Corporation, CACI International, Inc., and three detainees at Abu Ghraib. Written sworn statements were prepared as a result of these interviews. Several personnel invoked their rights under Article 31, Uniform Code of Military Justice (UCMJ) and the 5th Amendment of the US Constitution. In these cases and in cases where no sworn statements were collected, Memoranda for Record (MFR) were prepared to describe the nature of and information addressed in the interview.

(3) (U) Over 9,000 documents were collected, catalogued and archived into a database. Advanced analytic tools were used to organize, collate, and analyze this data as well as all collected interview data. Other analytical tools were used to prepare graphic representations of the data.

(4) (U) The investigative team consisted of 26 personnel to include investigators, analysts, subject matter experts and legal advisors.

SUBJECT: (U) AR 15-6 Investigation of the Abu Ghraib Detention Facility and
205th MI Brigade

2. (U) Executive Summary

a. (U) Background.

(1) (U) This investigation was ordered initially by LTG Ricardo S. Sanchez, Commander, CJTF-7. LTG Sanchez appointed MG George R. Fay as investigating officer under the provisions of AR 381-10. MG Fay was appointed to investigate allegations that members of the 205 MI BDE were involved in detainee abuse at the Abu Ghraib Detention Facility. Specifically, he was to determine whether 205 MI BDE personnel requested, encouraged, condoned, or solicited MP personnel to abuse detainees and whether MI personnel comported with established interrogation procedures and applicable laws and regulations. The investigative team conducted a comprehensive review of all available background documents and statements pertaining to Abu Ghraib from a wide variety of sources. Over 170 persons were interviewed concerning their knowledge of interrogation and detention operations at Abu Ghraib and/or their knowledge of and involvement in detainee abuse. On 16 June 2004, GEN Paul J. Kern, Commander, US Army Materiel Command (AMC), was appointed as the new Procedure 15 appointing authority. On 25 June 2004, GEN Kern appointed LTG Jones, Deputy Commanding General, TRADOC, as an additional Procedure 15 investigating officer. MG Fay was retained as an investigating officer.

(2) (U) This investigation identified forty-four (44) alleged instances or events of detainee abuse committed by MP and MI Soldiers, as well as civilian contractors. On sixteen (16) of these occasions, abuse by the MP Soldiers was, or was alleged to have been, requested, encouraged, condoned, or solicited by MI personnel. The abuse, however, was directed on an individual basis and never officially sanctioned or approved. MI solicitation of MP abuse included the use of isolation with sensory deprivation, removal of clothing and humiliation, the use of dogs as an interrogation tool to induce fear, and physical abuse. In eleven (11) instances, MI personnel were found to be directly involved in the abuse. MI personnel were also found not to have fully comported with established interrogation procedures and applicable laws and regulations. Theater Interrogation and Counter-Resistance Policies (ICRP) were found to be poorly defined, and changed several times. As a result, interrogation activities sometimes crossed into abusive activity.

(3) (U) This investigation found that certain individuals committed offenses in violation of international and US law to include the Geneva Conventions and the UCMJ and violated Army Values. Leaders in key positions failed properly to supervise the interrogation operations at Abu Ghraib and failed to understand the dynamics created at Abu Ghraib. Leaders also failed to react appropriately to those instances where detainee abuse was reported, either by other service members, contractors, or by the International Committee of the Red Cross (ICRC). Fifty-four (54) MI, MP, and Medical Soldiers, and civilian contractors were found to have some degree of

SUBJECT: (U) AR 15-6 Investigation of the Abu Ghraib Detention Facility and
205th MI Brigade

responsibility or complicity in the abuses that occurred at Abu Ghraib. Twenty-seven (27) were cited in this report for some degree of culpability and seventeen (17) were cited for misunderstanding of policy, regulation or law. Three (3) MI Soldiers, who had previously received punishment under UCMJ, were recommended for additional investigation. Seven (7) MP Soldier identified in the MG Taguba Report and currently under criminal investigation and/or charges are also central figures in this investigation and are included in the above numbers. One (1) person cited in the MG Taguba Report was exonerated.

(4) (U) Looking beyond personal responsibility, leader responsibility and command responsibility, systemic problems and issues also contributed to the volatile environment in which the abuse occurred. These systemic problems included: inadequate interrogation doctrine and training, an acute shortage of MP and MI Soldiers, the lack of clear lines of responsibility between the MP and MI chains of command, the lack of a clear interrogation policy for the Iraq Campaign, and intense pressure felt by the personnel on the ground to produce actionable intelligence from detainees. Twenty-four (24) additional findings and two (2) observations regarding systemic failures are included in the final investigative report. These findings ranged from doctrine and policy concerns, to leadership and command and control issues, to resource and training issues.

b. (U) Problems: Doctrine, Policy, Training, Organization, and Other Government Agencies.

(1) (U) Inadequacy of doctrine for detention operations and interrogation operations was a contributing factor to the situations that occurred at Abu Ghraib. The Army's capstone doctrine for the conduct of interrogation operations is Field Manual (FM) 34-52, Intelligence Interrogation, dated September 1992. Non-doctrinal approaches, techniques, and practices were developed and approved for use in Afghanistan and GTMO as part of the Global War on Terrorism (GWOT). These techniques, approaches, and practices became confused at Abu Ghraib and were implemented without proper authorities or safeguards. Soldiers were not trained on non-doctrinal interrogation techniques such as sleep adjustment, isolation, and the use of dogs. Many interrogators and personnel overseeing interrogation operations at Abu Ghraib had prior exposure to or experience in GTMO or Afghanistan. Concepts for the non-doctrinal, non field-manual approaches and practices came from documents and personnel in GTMO and Afghanistan. By October 2003, interrogation policy in Iraq had changed three times in less than thirty days and it became very confusing as to what techniques could be employed and at what level non-doctrinal approaches had to be approved.

(2) (U) MP personnel and MI personnel operated under different and often incompatible rules for treatment of detainees. The military police referenced DoD-wide regulatory and procedural guidance that clashed with the theater interrogation and counter-resistance policies that the military intelligence interrogators followed. Further, it appeared that neither group knew

SUBJECT: (U) AR 15-6 Investigation of the Abu Ghraib Detention Facility and
205th MI Brigade

or understood the limits imposed by the other's regulatory or procedural guidance concerning the treatment of detainees, resulting in predictable tension and confusion. This confusion contributed to abusive interrogation practices at Abu Ghraib. Safeguards to ensure compliance and to protect against abuse also failed due to confusion about the policies and the leadership's failure to monitor operations adequately.

(3) (U) By December 2003, the JIDC at Abu Ghraib had a total of approximately 160 personnel with 45 interrogators and 18 linguists/translators assigned to conduct interrogation operations. These personnel were from six different MI battalions and groups – the 519 MI BN, 323 MI BN, 325 MI BN, 470 MI GP, the 66th MI GP, the 500 MI GP. To complicate matters, interrogators from a US Army Intelligence Center and School, Mobile Training Team (MTT) consisting of analysts and interrogators, and three interrogation teams consisting of six personnel from GTMO, came to Abu Ghraib to assist in improving interrogation operations. Additionally, contract interrogators from CACI and contract linguists from Titan were hired in an attempt to address shortfalls. The JIDC was created in a very short time period with parts and pieces of various units. It lacked unit integrity, and this lack was a fatal flaw.

(4) (U) The term Other Government Agencies (OGA) most commonly referred to the Central Intelligence Agency (CIA). The CIA conducted unilateral and joint interrogation operations at Abu Ghraib. The CIA's detention and interrogation practices contributed to a loss of accountability and abuse at Abu Ghraib. No memorandum of understanding existed on the subject interrogation operations between the CIA and CJTF-7, and local CIA officers convinced military leaders that they should be allowed to operate outside the established local rules and procedures. CIA detainees in Abu Ghraib, known locally as "Ghost Detainees," were not accounted for in the detention system. With these detainees unidentified or unaccounted for, detention operations at large were impacted because personnel at the operations level were uncertain how to report or classify detainees.

c. (U) Detainee Abuse at Abu Ghraib.

(1) (U) Physical and sexual abuses of detainees at Abu Ghraib were by far the most serious. The abuses spanned from direct physical assault, such as delivering head blows rendering detainees unconscious, to sexual posing and forced participation in group masturbation. At the extremes were the death of a detainee in OGA custody, an alleged rape committed by a US translator and observed by a female Soldier, and the alleged sexual assault of a female detainee. These abuses are, without question, criminal. They were perpetrated or witnessed by individuals or small groups. Such abuse can not be directly tied to a systemic US approach to torture or approved treatment of detainees. The MPs being prosecuted claim their actions came at the direction of MI. Although self-serving, these claims do have some basis in fact. The environment created at Abu Ghraib contributed to the occurrence of such abuse and the fact that

SUBJECT: (U) AR 15-6 Investigation of the Abu Ghraib Detention Facility and
205th MI Brigade

it remained undiscovered by higher authority for a long period of time. What started as nakedness and humiliation, stress and physical training (exercise), carried over into sexual and physical assaults by a small group of morally corrupt and unsupervised Soldiers and civilians.

(2) (U) Abusing detainees with dogs started almost immediately after the dogs arrived at Abu Ghraib on 20 November 2003. By that date, abuses of detainees was already occurring and the addition of dogs was just one more device. Dog Teams were brought to Abu Ghraib as a result of recommendations from MG G. Miller's assessment team from GTMO. MG G. Miller recommended dogs as beneficial for detainee custody and control issues. Interrogations at Abu Ghraib, however, were influenced by several documents that spoke of exploiting the Arab fear of dogs. The use of dogs in interrogations to "fear up" detainees was utilized without proper authorization.

(3) (U) The use of nudity as an interrogation technique or incentive to maintain the cooperation of detainees was not a technique developed at Abu Ghraib, but rather a technique which was imported and can be traced through Afghanistan and GTMO. As interrogation operations in Iraq began to take form, it was often the same personnel who had operated and deployed in other theaters and in support of GWOT, who were called upon to establish and conduct interrogation operations in Abu Ghraib. The lines of authority and the prior legal opinions blurred. They simply carried forward the use of nudity into the Iraqi theater of operations. The use of clothing as an incentive (nudity) is significant in that it likely contributed to an escalating "de-humanization" of the detainees and set the stage for additional and more severe abuses to occur.

(4) (U) There was significant confusion by both MI and MPs between the definitions of "isolation" and "segregation." LTG Sanchez approved the extended use of isolation on several occasions, intending for the detainee to be kept apart, without communication with their fellow detainees. His intent appeared to be the segregation of specific detainees. The technique employed in several instances was not, however, segregation but rather isolation - the complete removal from outside contact other than required care and feeding by MP guards and interrogation by MI. Use of isolation rooms in the Abu Ghraib Hard Site was not closely controlled or monitored. Lacking proper training, clear guidance, or experience in this technique, both MP and MI stretched the bounds into further abuse; sensory deprivation and unsafe or unhealthy living conditions. Detainees were sometimes placed in excessively cold or hot cells with limited or poor ventilation and no light.

3. (U) Background and Environment.

a. (U) Operational Environment.

SUBJECT: (U) AR 15-6 Investigation of the Abu Ghraib Detention Facility and
205th MI Brigade

(1) (U) The Global War on Terrorism began in earnest on 11 September 2001 (9/11). Soon after the 9/11 attacks, American forces entered Afghanistan to destroy the primary operating and training base of Al Qaida. Prisoners collected in these and other global counter-terrorist operations were transferred to Guantanamo Naval Base, Cuba. Two Task Forces were formed at JTF-GTMO to manage intelligence collection operations with the newly captured prisoners. Military and civilian interrogators, counterintelligence agents, analysts, and other intelligence personnel from a variety of services and agencies manned the task forces and exploited the captured personnel for information.

(2) (U) US and coalition partners attacked Iraq on 20 March 2003 and soon after toppled Saddam Hussein's regime. The Iraq conflict transitioned quickly and unexpectedly to an insurgency environment. Coalition forces began capturing and interrogating alleged insurgents. Abu Ghraib prison, opened after the fall of Saddam to house criminals, was soon used for collecting and interrogating insurgents and other persons of intelligence interest. The unit responsible for managing Abu Ghraib interrogations was the 205 MI BDE.

b. (U) Law, Policy, Doctrine and Training.

(1) (U) Applicable Law.

(a) (U) Military Order of November 13th 2001 – Detention, Treatment and Trial of Certain Non-Citizens in the War Against Terrorism (Reference Annex J, Appendix 1).

(b) (U) Geneva Convention (IV) Relative to the Protection of Civilian Persons in Time of War, 12 August 1949 (Reference Annex J, Appendix 5).

(c) (U) AR 190-8 / OPNAVINST 3461.6 / AFJI 31-302/MCO 3461.1, Enemy Prisoners of War, Retained Personnel, Civilian Internees and other Detainees, 1 October 1997 (Reference Annex M, Appendix 2).

(d) (U) FM 34-52, Intelligence Interrogation, 28 September 1992 (Reference Annex M, Appendix 3).

(e) (U) Classification of Detainees. The overwhelming evidence in this investigation shows that most "detainees" at Abu Ghraib were "civilian internees." Therefore, this discussion will focus on "civilian internees."

[1] (U) Detainee. AR 190-8 defines a detainee as any person captured or otherwise detained by an armed force. By this definition, a detainee could be an Enemy Prisoner of War (EPW), a Retained Person, such as a doctor or chaplain, or a Civilian Internee. The term

SUBJECT: (U) AR 15-6 Investigation of the Abu Ghraib Detention Facility and
205th MI Brigade

“detainee” is a generic one with no specific implied rights or protections being afforded to the individual; however, it is almost exclusively used by the Soldiers and other individuals interviewed in this investigation to refer to the individuals interned at Abu Ghraib. In order to understand the rights and protections that need to be provided to a “detainee,” further classification is necessary.

[2] (U) Civilian Internee. Using Geneva Convention IV (GC IV), Article 78, as further defined by AR 190-8, a “Civilian Internee” is someone who is interned during armed conflict or occupation for security reasons or for protection or because he has committed an offense against the detaining power. (Reference Annex H, Appendix 1, FRAGO 749 to CJTF-7 OPOD 03-036). The overwhelming evidence in this investigation shows that all “detainees” at Abu Ghraib were civilian internees. Within the confinement facility, however, there were further sub-classifications that were used, to include criminal detainee, security internee, and MI Hold.

[a] (U) Criminal Detainee. A person detained because he/she is reasonably suspected of having committed a crime against Iraqi Nationals or Iraqi property or a crime not related to the coalition force mission (Reference Annex H, Appendix 1, FRAGO 749 to CJTF-7 OPOD 03-036).

[b] (U) Security Internee. Civilians interned during conflict or occupation for their own protection or because they pose a threat to the security of coalition forces, or its mission, or are of intelligence value. This includes persons detained for committing offenses (including attempts) against coalition forces (or previous coalition forces), members of the Provisional Government, Non-Government Organizations, state infrastructure, or any person accused of committing war crimes or crimes against humanity. Security internees are a subset of civilian internees (Reference Annex H, Appendix 1, FRAGO 749 to CJTF-7 OPOD 03-036).

[c] (U) MI Hold. A directive to hold and not release a detainee/internee in the custody of the Coalition Forces, issued by a member or agent of a US Military Intelligence Organization (Reference Annex H, Appendix 1, FRAGO 749 to CJTF-7 OPOD 03-036).

[d] (U) Most detainees located within Abu Ghraib, to include those in Tier 1A and 1B (Reference Annex F, Appendix 1, Abu Ghraib Overhead with Organizational Layout), were Civilian Internees and therefore, entitled to protections under GC IV. In addition to applicable international laws, ARs, and the FMs on Intelligence Interrogations further clarify US Policy regarding the protections afforded Civilian Internees.

(f) (U) Geneva Convention Relative to the Protection of Civilians in Time of War. GC IV provides protections for civilians in time of war. The US is bound by the Geneva Conventions; therefore, any individual acting on behalf of the US during an armed conflict is

SUBJECT: (U) AR 15-6 Investigation of the Abu Ghraib Detention Facility and
205th MI Brigade

also bound by Geneva Conventions. This includes not only members of the armed forces, but also civilians who accompany or work with the US Armed Forces. The following are some relevant articles to the discussion on detainee abuse:

[1] (U) Article 5. Where in the territory of a Party to the conflict, the latter is satisfied that an individual protected person is definitely suspected of or engaged in activities hostile to the security of the State, such individual person shall not be entitled to claim such rights and privileges under the present Conventions as would, if exercised in the favor of such individual person, be prejudicial to the security of such State. Where in occupied territory an individual protected person is detained as a spy or saboteur, or as a person under definite suspicion of activity hostile to the security of the Occupying Power, such person shall, in those cases where absolute military security so requires, be regarded as having forfeited rights of communication under the present Conventions. In each case, such persons shall nevertheless be treated with humanity and, in case of trial, shall not be deprived of the rights of fair and regular trial prescribed by the present [convention].

[2] (U) Article 27. Protected persons are entitled, in all circumstances, to respect for their persons, their honor, their family rights, their religious convictions and practices, and their manner and customs. They shall at all times be humanely treated, and shall be protected against all acts of violence or threats thereof and against insults and public curiosity.

[3] (U) Article 31. No physical or moral coercion shall be exercised against protected persons, in particular to obtain information from them or from third parties.

[4] (U) Article 32. The [Parties to the Convention] agree that each of them is prohibited from taking any measure of such a character as to cause the physical suffering or extermination of protected persons in their hands. This prohibition applies not only to murder, torture, corporal punishments, mutilation and medical and scientific experiments not necessitated by the medical treatment of a protected person, but also to any other measures of brutality whether applied by civilian or military agents.

[5] (U) Article 37. Protected persons who are confined pending proceedings or serving a sentence involving loss of liberty, shall during their confinement be humanely treated.

[6] (U) Article 100. The disciplinary regime in places of internment shall be consistent with humanitarian principles, and shall in no circumstances include regulation imposing on internees any physical exertion dangerous to their health or involving physical or moral victimization. Identification by tattooing or imprinting signs on the body is prohibited. In particular, prolonged standing and roll-calls, punishment drills, military drill and maneuver, or the reduction of food rations, are prohibited.

SUBJECT: (U) AR 15-6 Investigation of the Abu Ghraib Detention Facility and
205th MI Brigade

[7] (U) Article 143. Representatives or delegates of the Protecting Powers shall have permission to go to all places where protected persons are, particularly to places of internment, detention and work. They shall have access to all premises occupied by protected persons and shall be able to interview the latter without witnesses, personally or through an interpreter. Such visits may not be prohibited except for reasons of military imperative, and then only as an exceptional and temporary measure. Their duration and frequency shall not be restricted. Such representatives and delegates shall have full liberty to select the places they wish to visit. The Detaining or Occupying Power, the Protecting Power, and when occasion arises the Power of origin of the persons to be visited, may agree that compatriots of the internees shall be permitted to participate in the visits. The delegates of the International Committee of the Red Cross shall also enjoy the above prerogatives. The appointment of such delegates shall be submitted for the approval of the Power governing the territories where they will carry out their duties.

(2) (U) AR 190-8, Enemy Prisoners of War, Retained Personnel, Civilian Internees and other Detainees is a joint publication between all services of the Armed Forces (Reference Annex M, Appendix 2).

(a) (U) US Policy Overview. The regulation (Reference Annex M, Appendix 2, AR 190-8, Paragraph 1-5) sets out US Policy stating that "US policy, relative to the treatment of EPW, Civilian Internees and RP in the custody of the US Armed Forces, is as follows: All persons captured, detained, interned, or otherwise held in US Armed Forces custody during the course of conflict will be given humanitarian care and treatment from the moment they fall into the hands of the US forces until final release and repatriation." The regulation further defines this policy.

(b) (U) Inhumane Treatment. Specifically, inhumane treatment of detainees is prohibited and is considered a serious and punishable offense under international law and the UCMJ. The following acts are prohibited: murder, torture, corporal punishment, mutilation, the taking of hostages, sensory deprivation, collective punishment, execution without trial, and all cruel and degrading treatment. (Reference Annex M, Appendix 2, AR 190-8, Paragraph 1-5(b)).

(c) (U) Protection from Certain Acts. All detainees will be protected against all acts of violence to include rape, forced prostitution, assault and theft, insults, public curiosity, bodily injury, and reprisals of any kind. (Reference Annex M, Appendix 2, AR 190-8, Paragraph 1-5(c)). This is further reinforced in FM 34-52 (Reference Annex M, Appendix 3), which states that the Geneva Conventions and US policy expressly prohibit acts of violence or intimidation, including physical or mental torture, threats, insults, or exposure to inhumane treatment as a means of or aid to interrogation.

SUBJECT: (U) AR 15-6 Investigation of the Abu Ghraib Detention Facility and
205th MI Brigade

(d) (U) Photographs. Photographs of detainees are strictly prohibited except for internal administrative purposes of the confinement facility. (Reference Annex M, Appendix 2, AR 190-8, Paragraph 1-5(d)).

(e) (U) Physical torture or moral coercion. No form of physical or moral coercion will be exercised against the Civilian Internee. (Reference Annex M, Appendix 2, AR 190-8, Paragraph 1-5(a)(1)).

(f) (U) At all times, the Civilian Internee will be humanely treated and protected against all acts of violence or threats and insults and public curiosity. The Civilian Internee will be especially protected against all acts of violence, insults, public curiosity, bodily injury, reprisals of any kind, sexual attacks such as rape, forced prostitution, or any form of indecent assault. (Reference Annex M, Appendix 2, AR 190-8, Paragraph 1-5(a)(2) & (3)).

(3) (U) Military Intelligence Doctrine and Training.

(a) (U) Doctrine.

[1] (U) The Army's capstone doctrine for the conduct of interrogation operations is FM 34-52, Intelligence Interrogation, dated September, 1992. This doctrine provides an adequate basis for the training of interrogators at the Soldier level (e.g., in the art of tactical interrogation and the Geneva Conventions); however, it is out of date with respect to the management and conduct of detainee operations. Joint Doctrine on the conduct of detainee operations is sparse even though the Army has operated JIDCs since 1989 in Operation JUST CAUSE, and because the Army is normally tasked by the Joint Force Commander to establish and manage EPW/Detainee operations for the deployed force (Reference Annex M, Appendix 1, APPENDIX G-3, Joint Publication 2-01, Joint Intelligence Support to Military Operations). National level doctrine, in the form of a Defense Intelligence Agency Manual (DIAM), also contains very little doctrinal basis for the conduct and management of joint interrogation operations. A critical doctrinal gap at the joint and service level is the role of national level agencies (e.g., other governmental agencies [OGA]) in detainee operations to include appropriate protocols for sharing valuable intelligence assets. The Center for Army Lessons Learned (CALL) reported the following in a recent assessment of Operation Iraqi Freedom detainee and interrogation operations (Reference Annex C, Appendix 5):

MP and MI doctrine at division and below must be modified for stability operations and support operations to reflect the need for long-term detention facilities and interrogation of captives at the tactical level.

SUBJECT: (U) AR 15-6 Investigation of the Abu Ghraib Detention Facility and
205th MI Brigade

[2] (U) It is possible that some of the unauthorized interrogation techniques employed in Iraq may have been introduced through the use of an outdated training manual (FM 34-52 dated 1987 vice FM 34-52 dated 1992). The superseded version (FM 34-52, dated 1987) has been used at various locations in OIF. In a prior AR 15-6 investigation of Camp Cropper (Reference Annex C, Appendix 2), the 1987 version was again used as the reference (Reference Annex M, Appendix 3). On 9 June 2004, CJTF-7 published an email (Reference Annex L, Appendix 4, email) that indicated the May 1987 version was used as CJTF-7's primary reference. The section encapsulated below from the 1987 version has been removed from the 1992 version of FM 34-52. To the untrained, the reference in the outdated version could appear as a license for the interrogator to go beyond the current doctrine as established in the current FM 34-52. The 1987 version suggests the interrogator controls lighting, heating, and configuration of the interrogation room, as well as the food, shelter, and clothing given to the source. The section from the 1987 version that could be misunderstood is from Chapter 3 and reads as follows:

FM 34-52 (1987) Chapter 3, Establish and Maintain Control. The interrogator should appear to be the one who controls all aspects of the interrogation to include the lighting, heating, and configuration of the interrogation room, as well as the food, shelter, and clothing given to the source. The interrogator must always be in control, he must act quickly and firmly. However, everything that he says and does must be within the limits of the Geneva and Hague Conventions, as well as the standards of conduct outlined in the UCMJ.

[3] (U) Doctrine provides the foundation for Army operations. A lack of doctrine in the conduct of non-conventional interrogation and detainee operations was a contributing factor to the abuses at Abu Ghraib.

(b) (U) Training

[1] (U) Formal US Army interrogation training is conducted at the Soldier level, primarily as part of a Soldier's Initial Entry Training (IET). There is no formal advanced interrogation training in the US Army. Little, if any, formal training is provided to MI leaders and supervisors (Commissioned Officers, Warrant Officers, and Non-Commissioned Officers) in the management of interrogation and detainee operations. These skills can only be developed in the unit environment through assignments to an interrogation unit, involvement in interrogation training exercises, or on deployments. Unfortunately, unit training and exercises have become increasingly difficult to conduct due to the high pace of deployments of interrogation personnel

SUBJECT: (U) AR 15-6 Investigation of the Abu Ghraib Detention Facility and
205th MI Brigade

and units. With very few exceptions, combined MI and MP training on the conduct of detainee operations is non-existent.

[2] (U) The IET course at the USAIC, Fort Huachuca, AZ, provides a 16.5 week course of instruction. The course consists of 758.2 hours of academic training time that includes collection prioritization, screening, planning and preparation, approaches, questioning, termination of interrogations, and report writing in the classroom and practical exercise environments. The course focuses on the conduct of tactical interrogations in conventional war. Each student receives eight hours of classroom training on AR 381-10, Army Intelligence Activities (Reference Annex M, Appendix 2) and FM 27-10, Law of Land Warfare (Reference Annex M, Appendix 3) and 184 hours of practical exercise. The student's understanding of the Geneva Conventions and Law of Land Warfare is continually evaluated as a critical component. If at any time during an exercise, the student violates the Geneva Conventions, they will fail the exercise. A failure does not eliminate the student from the course. Students are generally given the chance to recycle to the next class; however, egregious violations could result in dismissal from the course.

[3] (U) The reserve components use the same interrogator program of instruction as does the active component. They are exposed to the same classes and levels of instruction. Like the active component, the reserve components' training opportunities prior to deployment in recent years have been minimal, if any. Those slated for deployment to the JTF-GTMO attend the Intelligence Support to Counter Terrorism (ISCT) Course.

[4] (U) Army Regulations require interrogators to undergo refresher training on the Geneva Conventions annually. Units are also expected to conduct follow-up training for Soldiers to maintain and improve their interrogation skills. This becomes difficult given that Soldiers fresh from the basic interrogation course are deployed almost as soon as they arrive to their unit of assignment. This leaves little, if any, time to conduct that follow-on training with their unit to hone the skills they have learned in school. In addition to the unit deployments, the individual interrogators find themselves deployed to a wide variety of global engagements in a temporary duty status—not with their units of assignments. It is not uncommon for an individual to be deployed two or three times in the course of a year (e.g., the Balkans, Cuba [JTF-GTMO], Afghanistan, Iraq, or in support of Special Operations Forces [SOF]).

[5] (U) There is no formal advanced interrogation training in the US Army. The DoD manages a Strategic Debriefing Course for all services. While some of the skills are similar, the Strategic Debriefing Course is not an advanced interrogation course. Further, only interrogators being assigned to strategic debriefing assignments are authorized to attend this course. This prevents the tactical interrogator, the operator at Abu Ghraib, from further developing skills. Junior NCOs receive only limited interrogation-related training during his or

SUBJECT: (U) AR 15-6 Investigation of the Abu Ghraib Detention Facility and
205th MI Brigade

her advanced NCO courses--the Basic Non-Commissioned Officers Course (BNCOC) and the Advanced Non-commissioned Officer's Course (ANCOC). This limited training is restricted to the management of interrogation operations. The amount of time spent on the Geneva Conventions training during either of these courses is minimal. Officers receive limited training in interrogation or interrogation management in their entry level and advanced level courses. Like BNCOC and ANCOC, this training is focused on management and not the intricacies of interrogation operations or the legal restrictions applicable to interrogation operations.

[6] (U) Very little training is available or conducted to train command and staff elements on the conduct, direction, and oversight of interrogation operations. To address a portion of this shortfall, USAIC is standing up a course to teach the management of Human Intelligence to MI officers. A pilot course is scheduled and is designed to prepare the intelligence staffs (G2, S2) of a deploying Army Division with the capability to synchronize, coordinate, manage and de-conflict Counterintelligence and Human Intelligence (HUMINT) operations within the division's area of responsibility.

[7] (U) Most interrogator training that occurred at Abu Ghraib was on-the-job-training. The JIDC at Abu Ghraib conducted Interrogation Rules of Engagement (IROE) and interrogation operations training. The fast paced and austere environment limited the effectiveness of any training. After mid-September 2003, all Soldiers assigned to Abu Ghraib had to read a memorandum titled IROE, acknowledging they understood the ICRP, and sign a confirmation sheet indicating they had read and understood the ICRP. Most Soldiers have confirmed they received training on the IROE. See attached CJTF-7 IROE standard signature sheet (Reference Annex J, Appendix 4) to view an example.

[8] (U) MG G. Miller led an assessment team to Abu Ghraib in early September 2003. This was followed by a training team from 2 October - 2 December 2003. There is no indication that the training provided by the JTF-GTMO Team led to any new violations of the Geneva Conventions and the law of land warfare. Training focused on screening, the use of pocket litter during interrogations, prioritization of detainees, planning and preparation, approaches, questioning, interpreter control, deception detection, reporting, automation, and interrogation booths. The training provided at Abu Ghraib did not identify the abuses that were ongoing as violations of regulations or law, nor did it clarify issues involving detainee abuse reporting.

[9] (U) Interrogators learn as part of their training that the MPs provide the security for and run detention operations at the Collection Points (CPs), Corps Holding Areas (CHAs), and Internment/Resettlement (IR) facilities. The interrogator's mission is only to collect intelligence from prisoners or detainees. Interaction with the MPs is encouraged to take advantage of any observations the MPs/guards might have concerning a particular prisoner or

SUBJECT: (U) AR 15-6 Investigation of the Abu Ghraib Detention Facility and
205th MI Brigade

detainee. While the USAIC includes this in the interrogator's training, very little time is spent training MI/MP detention operations. In the past, the Army conducted large EPW/Detainee exercises (the Gold Sword and Silver Sword series) that provided much of the training critical to MPs' and Interrogators' understanding of their respective roles and responsibilities. These exercises were discontinued in the mid 1990s due to frequent deployments and force structure reductions, eliminating an excellent source of interoperability training. The increase in op-tempo since 9/11 has further exacerbated the unit training and exercise problem.

[10] (U) Contract Training.

[a] (U) The US Army employs contract linguists/translators and contract interrogators in military operations. Some IET is provided to familiarize military interrogators in the conduct of interrogations using translators. No training is conducted at any level (enlisted, NCO, Warrant Officer, or Officer) on the employment of contract interrogators in military operations. The use of contract interrogators and linguists at Abu Ghraib was problematic (See paragraph 4.g.) from a variety of perspectives. JIDC interrogators, analysts, and leaders were unprepared for the arrival of contract interrogators and had no training to fall back on in the management, control, and discipline of these personnel.

[b] (U) No doctrine exists to guide interrogators and their intelligence leaders (NCO, Warrant Officer, and Officer) in the contract management or command and control of contractors in a wartime environment. These interrogators and leaders faced numerous issues involving contract management: roles and responsibilities of JIDC personnel with respect to contractors; roles, relationships, and responsibilities of contract linguists and contract interrogators with military personnel; and the methods of disciplining contractor personnel. All of these need to be addressed in future interrogation and interrogation management training.

[11] (U) Soldier interrogation training is adequate with respect to interrogation techniques and procedures for conventional warfare. It is far less suited to the realities of the GWOT and Stability and Support Operations (SASO) and contract management. Despite the emphasis on the Geneva Conventions, it is clear from the results at Abu Ghraib (and elsewhere in operations in support of the GWOT) that Soldiers on the ground are confused about how they apply the Geneva Conventions and whether they have a duty to report violations of the conventions. Most Abu Ghraib interrogators performed their duties in a satisfactory manner without incident or violation of training standards. Some interrogators (See paragraph 5.e.- 5.h., below), however, violated training standards in the performance of selected interrogations. Army training at USAIC never included training on interrogation techniques using sleep adjustment, isolation, segregation, environmental adjustment, dietary manipulation, the use of military working dogs, or the removal of clothing. These techniques were introduced to selected interrogators who worked at Abu Ghraib from sources other than official Army training.

SUBJECT: (U) AR 15-6 Investigation of the Abu Ghraib Detention Facility and
205th MI Brigade

(4) (U) Military Police Doctrine and Training

(a) (U) DoD Directives 2310.1, DoD Program for Enemy Prisoners of War and Other Detainees, and 5100.77, DoD Law of War Program, require that the US military services comply with the principles, spirit, and intent of international laws of war, that the DoD observes and enforces the US obligations under the laws of war, that personnel know the laws of war obligations, and that personnel promptly report incidents violating the laws of war and that the incidents be thoroughly investigated.

(b) (U) AR 190-8, "Enemy Prisoner of War, Retained Personnel Civilian Internees and other Detainees," is a multi-service policy that incorporates the directives from the DoD publications above. The regulation addresses the military police treatment of civilian internees, and directs that:

- No physical or moral coercion be used
- Internees be treated with respect for their person, honor, manner, and customs
- Internees be protected against violence, insults, public curiosity, bodily injury, or any form of indecent assault

It specifically prohibits:

- Measures causing physical suffering, to include corporal punishment, and other measures of brutality

It specifies that disciplinary measures NOT:

- Be inhumane, brutal, or dangerous to health
- Include imprisonment in a place without daylight

The authorized disciplinary punishments include:

- Discontinuance of privileges granted over and above the treatment provided for by regulation
- Confinement, not to exceed 30 consecutive days

(Reference Annex M, Appendix 2, AR 190-8)

(c) (U) AR 190-12, Military Working Dog Program, notes that military police may potentially use dogs for EPW control, but limits their use against people to instances when the

SUBJECT: (U) AR 15-6 Investigation of the Abu Ghraib Detention Facility and
205th MI Brigade

responsible commander determines it absolutely necessary and there have been reasonable efforts to use all lesser means of force. (Reference Annex M, Appendix 2, AR 190-12)

(d) (U) Procedural guidance, found in FM 3-19.40 and the MP Standard Operating Procedure (SOP) for Abu Ghraib (400th MP BN SOP for Camp Vigilant Detention Center), consistently follow directly from the DoD directives and the applicable ARs. The procedural guidance provides military police clear-cut guidance for permissible and impermissible practices during Internment Operations. (Reference Annex M, Appendix 3, FM 3-19.40; Annex J, Appendix 4, 400 MP BN SOP Camp Vigilant Detention Center)

(5) (U) Intelligence and Interrogation Policy Development.

(a) (U) National Policy.

(1) (U) US forces and intelligence officials deployed to Afghanistan and elsewhere to conduct military operations pursuant to GWOT. Specific regulatory or procedural guidance concerning either “humane” treatment or “abuse” was not available in the context of GWOT and the recently promulgated national policies. Military and civilian intelligence agencies, to include the 519th MI Battalion (519 MI BN) in late 2002, conducted interrogations in Afghanistan in support of GWOT. As a result, deployed military interrogation units and intelligence agencies in Afghanistan developed certain practices. Later, some of these same techniques surfaced as interrogation techniques in Iraq. Prior to these deployments, US Army interrogators used the doctrine found in FM 34-52. The 1992 FM was what military interrogators at Abu Ghraib were trained on, and it contained the techniques and the restrictions they had been taught. (Reference Annex M, Appendix 3; FM 34-52, Interrogation Operations, [1987 and 1992 versions])

(2) (~~S//NF~~)

SECRET//NOFORN//X1

SUBJECT: (U) AR 15-6 Investigation of the Abu Ghraib Detention Facility and
205th MI Brigade

(3) ~~(S//NF)~~

SECRET//NOFORN//X1

SUBJECT: (U) AR 15-6 Investigation of the Abu Ghraib Detention Facility and
205th MI Brigade

(4) (~~S//NF~~)

(5) (U) On 16 April 2003, SECDEF approved approaches for use on the Guantanamo “unlawful” combatants, as defined by the President’s Military Order of 13 November 2001 and reiterated in the 7 February 2002 memorandum to DoD. Once this document was signed, it became policy at JTF-GTMO, and later became the bedrock on which the CJTF-7 policies were based. The first 18 approaches listed in the 16 April 2003 memo from the SECDEF all appear in the current, 1992, FM 34-52, except the Mutt-and-Jeff approach, which was derived from the superseded 1987 FM 34-52. The remaining approaches, similar to the ones identified in the OGC working group’s memorandum derived from the CJTF-180 memorandum and the JTF-GTMO request, included:

- Change of Scenery Down
- Dietary Manipulation
- Environmental Manipulation
- Sleep Adjustment
- False Flag
- Isolation

Although approving all approaches for use, the SECDEF required that he be notified prior to implementing the following approaches:

Incentive/Removal of Incentive	Mutt and Jeff
Pride and Ego Down	Isolation

SUBJECT: (U) AR 15-6 Investigation of the Abu Ghraib Detention Facility and
205th MI Brigade

(Reference Annex J, Appendix 2, Counter-Resistance Techniques)

(6) (U) No regulatory guidance exists for interrogators aside from DoD Directives 2310.1, DoD Program for Enemy Prisoners of War and Other Detainees and 5100.77, DoD Law of War Program. The most current interrogation procedural guidance is in the 1992 FM 34-52. (Reference Annex M, Appendix 1, DoD Directive 2310.1; Annex M, Appendix 1, DoD Directive 5100.77).

(b) (U) Development of Intelligence and Interrogation Policy in Iraq and Abu Ghraib.

(1) (U) In July 2003, the 519 MI BN, veterans of Afghanistan already at the BIAP facility, simultaneously conducted interrogations of the detainees with possible information of intelligence value and began to develop IROE for interrogators to meet the newly-focused mission. No known documentation exists concerning specific approaches and techniques used before September 2003.

(2) (~~S//NF~~)

(3) (U) Meanwhile, at Headquarters, CJTF-7, as the need for actionable intelligence rose, the realization dawned that pre-war planning had not included planning for detainee operations. Believing that FM 34-52 was not sufficiently or doctrinally clear for the situation in Iraq, CJTF-7 staff sought to synchronize detainee operations, which ultimately resulted in a methodology and structure derived from the JTF-GTMO system as presented by MG G. Miller. At the same time, LTG Sanchez directed that an interrogation policy be established that would address "permissible techniques and safeguards for interrogators" for use in Iraq. The CJTF-7

SUBJECT: (U) AR 15-6 Investigation of the Abu Ghraib Detention Facility and
205th MI Brigade

staff relied heavily on the series of SOPs which MG G. Miller provided to develop not only the structure, but also the interrogation policies for detainee operations (Reference Annex B, Appendix 1, SANCHEZ).

(4) (U) On 10 September 2003, CPT Fitch, assigned to the 205 MI BDE as the Command Judge Advocate, was tasked by COL Marc Warren, the Staff Judge Advocate (SJA) for CJTF-7, to work with MAJ Daniel Kazmier and MAJ Franklin D. Raab from the CJTF-7 Office of the Staff Judge Advocate (OSJA) to produce a set of interrogation rules. The OSJA identified interrogation policies from the SECDEF 16 April 2003 memo for JTF-GTMO operations. OSJA provided CPT Fitch the 16 April 2003 SECDEF memorandum, which he copied almost verbatim onto a document entitled CJTF-7 Interrogation and Counter-Resistance Policy (ICRP). This document was developed without reference to the 519 MI BN's July 2003 and August 2003 memos. CPT Fitch sent the policy memo to the 519 MI BN for coordination, and the 519 MI BN added the use of dogs, stress positions, sleep management, sensory deprivation, and yelling, loud music and light control from its 27 August 2003 memo. The use of all the techniques was to apply to interrogations of detainees, security internees, and EPWs. CPT Fitch finalized the combined memo and sent it back to the CJTF-7 SJA. It also went to the CJ-2, CJ-3, and the Commander, 205 MI BDE, who until that point had apparently not been involved in drafting or approving the policy. (Reference Annex B, Appendix 1, FITCH, KAZMIER; Annex J, Appendix 3, CJTF-7 Interrogation and Counter-Resistance Policy, [1st Draft], Annex J, Appendix 3, CJTF-7 Interrogation and Counter-Resistance Policy, [2nd Draft])

(5) (U) Between 10 and 14 September 2003, the OSJA at CJTF-7 changed the 10 September 2003 memo to reflect the addition of the techniques that were not included in the JTF-GTMO policy; i.e., the use of dogs, stress positions, and yelling, loud music, and light control. Upon the guidance and recommendation of the SJA staff, it was decided that LTG Sanchez would approve the use of those additional methods on a case-by-case basis.

(6) (~~S//NF~~)

SUBJECT: (U) AR 15-6 Investigation of the Abu Ghraib Detention Facility and
205th MI Brigade

(7) ~~(S//NF)~~

(8) ~~(S//NF)~~

(9) ~~(S//NF)~~

(10) (U) The 12 October 2003 policy significantly changed the tone and substance of the previous policy. It removed any approach not listed in the 1987 FM 34-52. While acknowledging the applicability of the Geneva Conventions and the duty to treat all detainees humanely, it also cited Articles 5 and 78 noting specifically that those “detainees engaged in activities hostile to security of coalition forces had forfeited their Geneva Convention rights of communication.” It also included provisions found in the superseded 1987 FM 34-52 that authorized interrogators to control all aspects of the interrogation, “to include lighting, and heating, as well as food, clothing and shelter given to detainees.” This phrase was specifically left out of the 1992 version (See section 3a(2), above). The 12 October 2003 policy also deleted references to EPWs and specified the policy was for use on civilian security internees.

(11) ~~(S//NF)~~

SUBJECT: (U) AR 15-6 Investigation of the Abu Ghraib Detention Facility and
205th MI Brigade

(12) (~~S//NF~~)

(13) (~~S//NF~~)

SUBJECT: (U) AR 15-6 Investigation of the Abu Ghraib Detention Facility and
205th MI Brigade

(14) ~~(S//NF)~~

(15) (U) On 16 October 2003, the JIDC Interrogation Operations Officer, CPT Carolyn A. Wood, produced an "Interrogation Rules of Engagement" chart as an aid for interrogators, graphically portraying the 12 October 2003 policy. It listed the approved approaches, and identified the approaches which had been removed as authorized interrogation approaches, which nonetheless could be used with LTG Sanchez's approval. The chart was confusing, however. It was not completely accurate and could be subject to various interpretations. For example, the approved approaches list left off two techniques which previously had been included in the list (the Pride and Ego Down approach and the Mutt and Jeff approach). The right side of the chart listed approaches that required LTG Sanchez's prior approval. What was particularly confusing was that nowhere on the chart did it mention a number of techniques that were in use at the time: removal of clothing, forced grooming, hooding, and yelling, loud music and light control. Given the detail otherwise noted on the aid, the failure to list some techniques left a question of whether they were authorized for use without approval. (Reference Annex J, Appendix 4, CJTF-7 IROE training card)

(16) (U) By mid-October, interrogation policy in Iraq had changed three times in less than 30 days. Various versions of each draft and policy were circulated among Abu Ghraib, 205 MI BDE, CJTF-7 C2, and CJTF-7 SJA. Anecdotal evidence suggests that personnel were confused about the approved policy from as early as 14 September 2003. The SJA believed that the 14 September 2003 policy was not to be implemented until CENTCOM approved it. Meanwhile, interrogators in Abu Ghraib began operating under it immediately. It was not always clear to JIDC officers what approaches required LTG Sanchez's approval, nor was the level of

SUBJECT: (U) AR 15-6 Investigation of the Abu Ghraib Detention Facility and
205th MI Brigade

approval consistent with requirements in other commands. The JIDC October 2003 SOP, likewise created by CPT Wood, was remarkably similar to the Bagram (Afghanistan) Collection Point SOP. Prior to deployment to Iraq, CPT Wood's unit (A/519 MI BN) allegedly conducted the abusive interrogation practices in Bagram resulting in a Criminal Investigation Command (CID) homicide investigation. The October 2003 JIDC SOP addressed requirements for monitoring interrogations, developing detailed interrogation plans, delegating interrogation plan approval authority to the Interrogation Officer in Charge (OIC), and report writing. It failed to mention details concerning ICRP, approval requirements or procedures. Interrogators, with their section leaders' knowledge, routinely utilized approaches/techniques without obtaining the required authority, indicating confusion at a minimum of two levels of supervision. (Reference Annex J, Appendix 4, JIDC Interrogation SOP; Annex J, Appendix 4, CJTF-180 Bagram Collection Point SOP)

(17) (U) Concepts for the non-doctrinal, non-field manual approaches and practices clearly came from documents and personnel in Afghanistan and Guantanamo. The techniques employed in JTF-GTMO included the use of stress positions, isolation for up to thirty days, removal of clothing, and the use of detainees' phobias (such as the use of dogs) as the 2 December 2002 Counter-Resistance memo, and subsequent statements demonstrate. As the CID investigation mentioned above shows, from December 2002, interrogators in Afghanistan were removing clothing, isolating people for long periods of time, using stress positions, exploiting fear of dogs and implementing sleep and light deprivation. Interrogators in Iraq, already familiar with the practice of some of these new ideas, implemented them even prior to any policy guidance from CJTF-7. These practices were accepted as SOP by newly-arrived interrogators. Some of the CJTF-7 ICRPs neither effectively addressed these practices, nor curtailed their use. (Annex J, Appendix 2, Tab A, Counter-Resistance Techniques; Annex J, Appendix 2, Interrogation Techniques; Annex E, Appendix 4, CID Report)

(18) ~~(S//REL TO USA and MCFI)~~

(6) (U) Other Regulatory Procedural Guidance

(a) (U) On 13 November 2001, the President issued a military order entitled the Detention, Treatment and Trial of Certain Non-Citizens in the War Against Terrorism. The

SUBJECT: (U) AR 15-6 Investigation of the Abu Ghraib Detention Facility and
205th MI Brigade

order authorized US military forces to detain non-US citizens suspected of terrorism, and try them for violations of the law of war and other applicable laws. The order also authorized the SECDEF to detain individuals under such conditions he may prescribe and to issue related orders and regulations as necessary. (Reference Annex J, Appendix 1, Presidential Military Order)

(b) (~~S//NF~~)

(c) (U) The MP personnel and the MI personnel operated under different and often incompatible rules for treatment of detainees. The MPs referenced DoD-wide regulatory and procedural guidance that clashed with the theater interrogation and counter-resistance policies that the MI interrogators followed. Further, it appears that neither group knew or understood the limits imposed by the other's regulatory or procedural guidance concerning the treatment of detainees, resulting in predictable tension and confusion.

(d) (U) For instance, a MI order to strip a detainee as an interrogation process conflicted with the AR 190-8 directive to treat detainees with respect for their person and honor (Reference Annex M, Appendix 2, AR 190-8, paragraph 5-1a(2)); or to protect detainees against violence, insults, public curiosity, or any form of indecent assault (Reference Annex M, Appendix 2, AR 190-8, paragraph 5-1a(3)); and FM 3-19.40 (Reference Annex M, Appendix 3) (which specifically directs that internees will retain their clothing). A MI order to place a detainee in isolation violated the AR 190-8 directive to not imprison a detainee in a place without daylight (Reference Annex M, Appendix 2, AR 190-8, paragraph 6-11a(5)); to not confine for more than 30 consecutive days, (Reference Annex M, Appendix 2, AR 190-8, paragraph 6-12d(1)); and FM 3-19.40 which specifically directs that the facility commander must authorize any form of punishment. Finally, when interrogators ordered the use of dogs as an interrogation technique, the order violated the policy and intent of AR 190-12. (Reference Annex M, Appendix 2)

4. (U) Summary of Events at Abu Ghraib.

SUBJECT: (U) AR 15-6 Investigation of the Abu Ghraib Detention Facility and 205th MI Brigade

a. (U) Military Intelligence Organization and Resources.

(1) (U) Task Organization.

(a) (U) The 205 MI BDE was organizationally, and geographically, the size of two MI Brigades. It was composed of four Active and three Reserve Battalions. The 205 MI BDE possessed no organic interrogation elements or personnel. All HUMINT assets (units and personnel) assigned to the 205 MI BDE were from other organizations. Major subordinate elements of the 205 MI BDE included three Tactical Exploitation Battalions (HUMINT and Counterintelligence), one Aerial Exploitation Battalion (Signal Intelligence [SIGINT]) and Imagery Intelligence (IMINT), an Operations Battalion (ANALYSIS), a Linguist Battalion (HUMINT Support) and a Corps Support Battalion (HUMINT). Elements of the Brigade were located throughout Iraq supporting a wide variety of combat operations. (Reference Annex H, Appendix 6, Tab C, 205 MI BDE Command Brief).

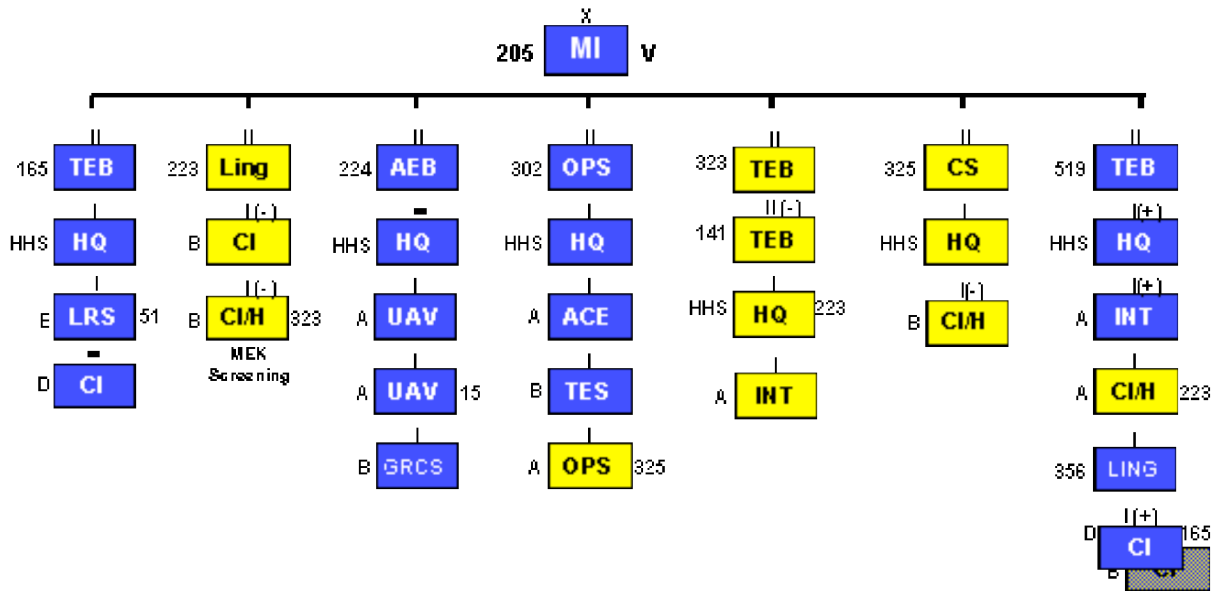

205th MI Brigade Task Organization (August 2003)

(b) (U) The 205 MI BDE Commander, COL Thomas Pappas, had a reputation for being an excellent MI officer with a great background and experience before being selected for command. He took command of the 205 MI BDE on 1 July 2003 while the unit was already deployed in Iraq. His performance as Brigade Commander prior to the Abu Ghraib incidents was “outstanding” according to his rater, MG Wojdakowski, DCG, V Corps/CJTF-7 (Reference Annex B, Appendix 1, WOJDAKOWSKI). LTG Sanchez also believed COL Pappas was an

SUBJECT: (U) AR 15-6 Investigation of the Abu Ghraib Detention Facility and
205th MI Brigade

excellent and dedicated officer (Reference Annex B, Appendix 1, SANCHEZ). Other key members of COL Pappas's staff included MAJ Potter, Deputy Commander; MAJ M. Williams, Brigade Operations Officer (S-3); and CPT Fitch, Command Judge Advocate.

(2) (U) Resources.

(a) (U) As hostilities began to shift from a tactical fight to an insurgency, so did intelligence priorities. Iraq quickly became a HUMINT-focused environment in support of SASO with interrogation operations representing the intelligence 'Center of Gravity' (Reference Annex B, Appendix 1, SANCHEZ). Beginning in July 2003, demands placed upon interrogation operations were growing rapidly from both the tactical commanders as well as from the CJTF-7. The 205 MI BDE had the missions of providing Tactical HUMINT Teams (THT - small elements consisting of an interrogator, a linguist, and several combat arms Soldiers attached to maneuver elements to conduct tactical interrogations at "the point of the spear") to forward-deployed combat forces as well as operating a Joint Interrogation and Debriefing Center (JIDC).

(b) (U) As previously mentioned, the 205 MI BDE had no organic interrogation capability. Those assets were eliminated from the active force structure during the down-sizing of the Army in the 1990's. The interrogation assets available to COL Pappas when he first took Command were A/519 MI BN and interrogation sections from the 325th MI Battalion (325 MI BN), US Army Reserve (USAR), and 323rd MI Battalion (323 MI BN), USAR. Because both of the USAR units were significantly under strength before being deployed to Iraq, they received many Soldiers from other USAR units country-wide to fill up their ranks. This process is known as "cross-leveling." Although it has the benefit of filling the ranks, it has the disadvantage of inserting Soldiers into units shortly before deployment who had never trained with those units. The Soldiers did not know the unit. The unit and the unit leadership did not know the Soldiers. The Army has always stressed "you train as you fight." As COL Pappas began to focus his efforts on interrogation operations, all he had were disparate elements of units and individuals, including civilians, that had never trained together, but now were going to have to fight together.

(c) (U) Interestingly, and as a matter of comparison, Iraqi Survey Group (ISG) interrogation operations of high-level detainees at BIAP suffered no such shortages of interrogators. Roughly the same level of personnel supported the ISG interrogation operations at BIAP, even though the ISG facility had an order of magnitude less of detainees of intelligence interest to exploit than did the 205 MI BDE (100 at BIAP vs. over a 1000 at Abu Ghraib). Unfortunately, these much needed resources were unavailable for support to critical CJTF-7 mission needs (Reference Annex B, Appendix 1, SANCHEZ).

(d) (U) The number of interrogators initially assigned to the 205 MI BDE was sufficient for a small detainee population of only several hundred. In late July 2003, only 14 interrogation

SUBJECT: (U) AR 15-6 Investigation of the Abu Ghraib Detention Facility and
205th MI Brigade

personnel were present in the 205 MI BDE to support interrogation operations at Abu Ghraib. All of these personnel were from one unit – A/519 MI BN. By December 2003, Abu Ghraib (the JIDC) had approximately 160 205 MI BDE personnel with 45 interrogators and 18 linguists/translators assigned to conduct interrogation operations. These personnel were from six different MI battalions and groups – the 519 MI BN, the 323 MI BN (USAR), the 325 MI BN (USAR), the 470th MI Group (470 MI GP), the 66th MI Group (66 MI GP), the 500th MI Group (500 MI GP). Additional resources in the form of interrogators from one MTT consisting of analysts and interrogators, and at just about the same time, three "Tiger Teams" consisting of six personnel from JTF-GTMO, came to Abu Ghraib to assist in improving interrogation operations (See paragraph 4.j.(2)). Still short of resources, the Army hired contract interrogators from CACI International, and contract linguists from Titan Corporation in an attempt to address shortfalls (See paragraph 4.g.). Some units, such as the A/519 MI BN, had personnel who had been deployed to combat operations in theater in excess of 400 days so they also faced a rotation of selected personnel home with the resulting personnel turmoil.

b. (U) Establishment of the Prison at Abu Ghraib.

(1) (U) The Coalition Provisional Authority (CPA) made the initial decision to use Abu Ghraib Prison as a criminal detention facility in May 2003 (Reference Annex B, Appendix 1, SANCHEZ). Abu Ghraib began receiving criminal prisoners in June 2003. There were no MI Holds or security detainees in the beginning. All such categories of detainees were sent to Camp Cropper (located at BIAP) or to the other existing facilities throughout the country such as Camp Bucca (Reference Annex F, Appendix 1, AG Overhead Photo).

(2) (~~S//NF~~)

SUBJECT: (U) AR 15-6 Investigation of the Abu Ghraib Detention Facility and
205th MI Brigade

(3) (U) The Hard Site permanent building facilities at Abu Ghraib were not open for occupancy until 25 August 2003. The opening of the Hard Site was important because it marked the beginning of the serious abuses that occurred. CPT Wood, A/519 MI BN, believed that, based on her experience, the availability of an isolation area to house detainees determined to be of MI value would enhance results. She initiated the request through the 205 MI BDE to CPA for use of part of the Hard Site building for that purpose. Her request received strong support from the 205 MI BDE, specifically from its Operations Officer, MAJ Williams. The 519 MI BN was then granted use of Tier 1A (Reference Annex F, Appendix 1, AG Overview Briefing for diagram) to house detainees.

c. (U) Detention Operations and Release Procedures

(1) (~~S//NF~~)

(2) (~~S//NF~~)

SUBJECT: (U) AR 15-6 Investigation of the Abu Ghraib Detention Facility and
205th MI Brigade

(3) (~~S//NF~~)

(4) (~~S//NF~~)

(5) (~~S//NF~~)

SECRET//NOFORN//X1

SUBJECT: (U) AR 15-6 Investigation of the Abu Ghraib Detention Facility and
205th MI Brigade

SECRET//NOFORN//X1

SUBJECT: (U) AR 15-6 Investigation of the Abu Ghraib Detention Facility and
205th MI Brigade

(6) (U) The problems cited above contributed significantly to the overcrowding at Abu Ghraib. Overcrowding was even further exacerbated with the transfer of detainees from Camp Bucca to Abu Ghraib. The physical plant was totally inadequate in size and the construction and renovations that were underway were incomplete. Scarcity of resources – both personnel and equipment – to conduct effective confinement or interrogation operations made the situation worse.

(7) (U) There was general consensus (Reference Annex B, Appendix 1, FAST, CIVILIAN-12, LYONS, WOOD, SOLDIER14, SANCHEZ) that as the pace of operations picked up in late November – early December 2003, it became a common practice for maneuver elements to round up large quantities of Iraqi personnel in the general vicinity of a specified target as a cordon and capture technique. Some operations were conducted at night resulting in some detainees being delivered to collection points only wearing night clothes or under clothes. SGT Jose Garcia, assigned to the Abu Ghraib Detainee Assessment Board, estimated that 85% - 90% of the detainees were of no intelligence value based upon board interviews and debriefings of detainees. The Deputy C2X, CJTF-7, CIVILIAN-12, confirmed these numbers. (Reference Annex B, Appendix 1, GARCIA, CIVILIAN-12). Large quantities of detainees with little or no intelligence value swelled Abu Ghraib's population and led to a variety of overcrowding difficulties. Already scarce interrogator and analyst resources were pulled from interrogation operations to identify and screen increasing numbers of personnel whose capture documentation was incomplete or missing. Complicated and unresponsive release procedures ensured that these detainees stayed at Abu Ghraib – even though most had no value.

(8) (U) To make matters worse, Abu Ghraib increasingly became the target of mortar attacks (Reference Annex F, Appendix 3 shows an image of mortar round strikes at Abu Ghraib prior to February 2004 and the times of mortar strikes from January-April 2004) which placed detainees – innocent and guilty alike – in harms way. Force protection was a major issue at Abu Ghraib. The prison is located in a hostile portion of Iraq, adjacent to several roads and highways, and near population centers. BG Karpinski recognized Abu Ghraib's vulnerabilities and raised these concerns frequently to both MG Wojdakowski and LTG Sanchez (Reference Annex B, Appendix 1, KARPINSKI). LTG Sanchez was equally concerned with both the inherent vulnerability of Abu Ghraib and frustrated with the lack of progress in establishing even rudimentary force protection measures and plans (Reference Annex B, Appendix 1, SANCHEZ). LTG Sanchez directed that measures be taken to improve the force protection situation even to the point of having the 82nd Airborne Division Commander meet with Abu Ghraib officers concerning the issue. But, little progress was made and the mortar attacks continued. In an effort to improve force protection at Abu Ghraib, LTG Sanchez directed COL Pappas assume Tactical Control (TACON) of the Abu Ghraib Forward Operating Base (FOB) (Reference Annex H, Appendix 1, FRAGO 1108) on 19 November 2003. COL Pappas devoted considerable energy to improving security, even to the point of bringing a subordinate battalion commander to Abu

SUBJECT: (U) AR 15-6 Investigation of the Abu Ghraib Detention Facility and
205th MI Brigade

Ghraib to coordinate force protection plans and operations. In spite of these efforts, the mortar attacks continued and culminated in an attack in April 2004 killing 22 detainees and wounding approximately 80 others, some seriously. This highlights the critical need for adequate force protection for a detainee center.

(9) (U) The Security Internee Review and Appeal Board was established on 15 August 2003. It served as the release authority for security internees and/or those on MI Hold who were deemed to be of no security threat or (further) intelligence value. It consisted of three voting members - the C2, CJTF-7 (MG Fast), the Commander 800 MP BDE (BG Karpinski), and the CJTF-7 SJA (COL Warren), and two non-voting members (a SJA recorder and a MI assistant recorder). When first instituted, it was to meet on an "as required" basis; however, it appeared to be difficult to balance the schedules of three senior officers and the necessary support staff on a recurring, regular basis. Due to poor record keeping, accurate detainee release statistics are not available. We do know that by 2 October 2003, only 220 files had been reviewed by the board (Reference Annex H, Appendix 9, 031002 Oct CJTF7 JA Memo for CG). A preliminary screening board (Appellate Review Panel) at a level of authority below the General Officers on the Security Internee Review and Appeal Board was established to speed up the review of files by the General Officers. In the October – November 2003 timeframe, only approximately 100 detainee files a week were considered for release (Reference Annex B, Appendix 1, SUMMERS). As the detainee population increased, it became necessary to have the meetings on a much more frequent basis – initially twice a week. In the January 2004 timeframe, the board was meeting six times a week (Reference Annex B, Appendix 1, FAST). By February 2004, a standing board was established to deal with the ever increasing backlog. Even with more frequent meetings, the release of detainees from Abu Ghraib did not keep pace with the inflow. BG Karpinski believed that MG Fast was unreasonably denying detainees' release. By 11 January 2004, 57 review boards had been held and 1152 detained personnel had been released out of a total of 2113 considered. From February 2004 on, the release flow increased. (Reference Annex C, Appendix 1, Tab B, Annex 104)

(10) (U) As of late May 2004, over 8500 detainees had been reviewed for release, with 5300 plus being released and 3200 plus being recommended for continued internment. (Reference Annex H, Appendix 9, CJTF-7 C2X email). Even those that were initially deemed of no intelligence value and those that had been drained of intelligence information were not released on a timely basis – not as the result of any specific policy, but simply because the system that supported the release board (screening, interviews, availability of accurate records, and coordination) and the release board itself could not keep up with the flow of detainees into Abu Ghraib. Even with these long release delays (often 6 months and longer), there were concerns between the intelligence and tactical sides of the house. Combat Commanders desired that no security detainee be released for fear that any and all detainees could be threats to coalition forces. On occasion, Division Commanders overturned the recommendations of

SUBJECT: (U) AR 15-6 Investigation of the Abu Ghraib Detention Facility and 205th MI Brigade

Division Staffs to release some detainees at the point of capture (Reference Annex B, Appendix 1, PHILLABAUM). The G2, 4 ID informed MG Fast that the Division Commander did not concur with the release of any detainees for fear that a bad one may be released along with the good ones. MG Fast described the 4ID's response to efforts to coordinate the release of selected detainees, "...we wouldn't have detained them if we wanted them released." (Reference Annex B, Appendix 1, FAST, CIVILIAN-12). MG Fast responded that the board would ultimately release detainees if there was no evidence provided by capturing units to justify keeping them in custody.

(11) (U) The chart below depicts the rise in detainee 'MI Hold' population (those identified by the "system" to be deemed of intelligence interest) (Reference Annex H, Appendix 5). SOLDIER-14, the officer at Abu Ghraib primarily responsible for managing collection requirements and intelligence reporting, estimated that only 10-15% of the detainees on MI Hold were of actual intelligence interest. (Reference Annex B, Appendix 1, SOLDIER-14)

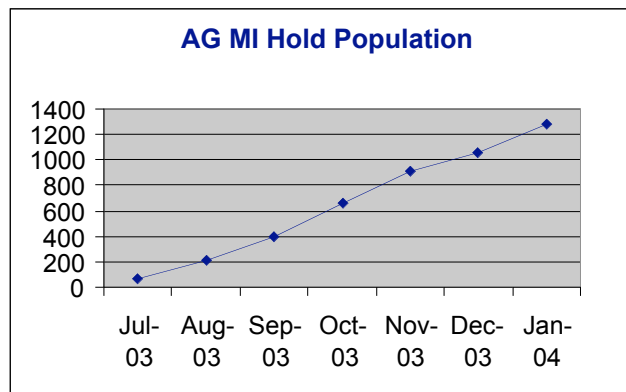

(12) (U) Interrogation operations in Abu Ghraib suffered from the effects of a broken detention operations system. In spite of clear guidance and directives, capturing units failed to perform the proper procedures at the point-of-capture and beyond with respect to handling captured enemy prisoners of war and detainees (screening, tactical interrogation, capture cards, sworn statements, transportation, etc.). Failure of capturing units to follow these procedures contributed to facility overcrowding, an increased drain on scarce interrogator and linguist resources to sort out the valuable detainees from innocents who should have been released soon after capture, and ultimately, to less actionable intelligence.

d. (U) Establishment of MP Presence at Abu Ghraib. The first Army unit to arrive was the 72nd MP Company (72 MP CO), Nevada Army National Guard. When first assigned to Abu Ghraib, the 72 MP CO was a subordinate unit of the 400th MP Battalion (400 MP BN)

SUBJECT: (U) AR 15-6 Investigation of the Abu Ghraib Detention Facility and
205th MI Brigade

headquartered at BIAP. The 320th MP Battalion (320 MP BN) advance party was the next to arrive at Abu Ghraib on 24 July 2003. The rest of the 320 MP BN Headquarters, commanded by LTC Phillabaum arrived on 28 July 2003. With the 320 MP BN came one of its subordinate units, the 447th MP Company (447 MP CO). The 72 MP CO was then reassigned from the 400 MP BN to the 320 MP BN. The next unit to arrive was the 229th MP Company (229 MP CO) on or about 3 August 2003. On 1 October 2003, SSG Frederick, CPL Graner and other MPs who have allegedly abused detainees, arrived as part of the 372 MP CO. The rest of the 320 MP CO arrived in late October 2003, followed by the 870th MP Company (870 MP CO) and 670 MP Company (670 MP CO) on approximately 14 November 2003.

e. (U) Establishment of MI Presence at Abu Ghraib.

(1) (U) The first MI unit to arrive at Abu Ghraib was a detachment from A/519 MI BN on 25 July 2003. The person in charge of that contingent was 1SGT McBride. Soldiers from the 519 MI BN had been sent there to prepare for OVB. CPT Wood arrived at Abu Ghraib on 4 August 2003 to assume the duties of Interrogation Operations OIC. MAJ Thompson arrived on or about 10 September 2003 along with elements of the 325 MI BN. MAJ Thompson was sent by COL Pappas to set up the JIDC at Abu Ghraib. LTC Jordan arrived at Abu Ghraib on 17 September 2003 to become the Director of the JIDC. MAJ Price and elements of the 323 MI BN arrived at the end of September 2003. MAJ Price had been the OIC of the interrogation operation at Camp Bucca. He became the Operations Officer of the JIDC, working closely with MAJ Thompson and CPT Wood. Most of the personnel from the 323 MI BN element that arrived with MAJ Price were used as the Headquarters element and did not directly participate in interrogations.

(2) (U) Civilian CACI contract interrogators began to arrive in late September 2003. There are a number of shortfalls connected to this issue (See paragraph 4.g., below). It was another complicating factor with respect to command and control. CPT Wood relied on the CACI site manager, CIVILIAN-18, to interview contractors as they arrived and to assign them based on his interviews. She knew little of their individual backgrounds or experience and relied on "higher headquarters" to screen them before arrival. Such screening was not occurring.

(3) (U) During October 2003, in addition to the elements of the already mentioned MI units and the Titan and CACI civilians, elements of the 470 MI GP, 500 MI GP, and 66 MI GP appeared. These units were from Texas, Japan, and Germany, and were part of the US Army Intelligence and Security Command (INSCOM), which tasked those subordinate units to send whatever interrogator and analyst support they had available. MAJ Thompson rotated back to the US on 15 November 2003. CPT Wood left on emergency leave on 4 December 2003 and never returned. MAJ Price, then, was the only commissioned officer remaining in the Operations Section.

SUBJECT: (U) AR 15-6 Investigation of the Abu Ghraib Detention Facility and
205th MI Brigade

(4) (U) It is important to understand that the MI units at Abu Ghraib were far from complete units. They were small elements from those units. Most of the elements that came to Abu Ghraib came without their normal command structure. The unit Commanders and Senior NCOs did not go to Abu Ghraib but stayed with the bulk of their respective units. The bringing together of so many parts of so many units, as well as civilians with very wide backgrounds and experience levels in a two month time period, was a huge challenge from a command and control perspective.

f. (U) Establishment, Organization, and Operation of the Joint Interrogation Debriefing Center (JIDC)

(1) (U) The idea for the creation of the JIDC came about after a number of briefings and meetings were held among LTG Sanchez, MG Fast, COL Pappas, and COL Steven Boltz, Assistant C2, CJTF-7. These meetings and briefings occurred about mid-August 2003 through early September 2003. They partially coincided with MG G. Miller's arrival from GTMO. He and his team provided an assessment of detainee operations in Iraq from 31 August to 9 September 2003 (See Paragraph 4.j.(1)). MG G. Miller's discussions with the CJTF personnel and the 205 MI BDE personnel influenced the decision to create a JIDC and how it would be organized, but those discussions were already underway before his arrival. The objective for the establishment of the JIDC was to enhance the interrogation process with a view toward producing better, timelier, actionable intelligence (actionable intelligence provides commanders and Soldiers a high level of situational understanding, delivered with speed, accuracy, and timeliness, in order to conduct successful operations).

(2) (U) On 6 September 2003, COL Pappas briefed LTG Sanchez on a plan to improve interrogation operations resulting from a 31 August 2003 meeting (Reference Annex H, Appendix 10). LTG Sanchez approved the concept and directed COL Pappas to accelerate all aspects of the plan. This decision established the JIDC and modified previous interrogation operations at Abu Ghraib. COL Pappas decided when standing up the JIDC not to make it a battalion operation (Reference Annex B, Appendix 1, WILLIAMS), therefore deciding not to place one of his battalion commanders in charge of the JIDC but instead rely upon staff personnel to manage the entire operation. The current operation would be transitioned to a JIDC by personnel already assigned at Abu Ghraib with additional manning provided by the consolidation of security detainee interrogation operations from other locations (e.g., Camp Cropper). LTC Jordan would become the Director of the JIDC on 17 September 2003. Other key JIDC personnel included CPT Wood (OIC ICE), MAJ Thompson (JIDC Operations Officer), MAJ Price (JIDC Operations Officer), SOLDIER-14 and SOLDIER-23 (Interrogation Technicians). CJTF-7 decided to use the JTF-GTMO Tiger Team concept which uses an interrogator, an intelligence analyst, and an interpreter on each team. A re-organization of the

SUBJECT: (U) AR 15-6 Investigation of the Abu Ghraib Detention Facility and
205th MI Brigade

JIDC took place in the late September to October 2003 timeframe which divided Tiger Teams into functional categories.

(3) (U) The reorganization introduced another layer of complexity into an already stressed Abu Ghraib interrogation operations environment. The Tiger Team worked well at GTMO. JTF-GTMO's target population and mission, however, were different from what was faced in Iraq. The Tiger Team method was designed to develop strategic level information from the GTMO detainees who were primarily captured in Afghanistan. By the time they reached GTMO any tactical value they may have had was gone. The same is true for Abu Ghraib relative to Iraq. The best place to collect tactical intelligence from interrogations is at the tactical level. Tactical intelligence is the most perishable, and the faster you harvest it the more useful it will be to help that tactical unit. JIDC personnel at Abu Ghraib believed the thirst for intelligence reporting to feed the national level systems was driving the train. There was then a focus to fill that perceived void and feed that system. LTG Sanchez did not believe significant pressure was coming from outside of CJTF-7, but does confirm that there was great pressure placed upon the intelligence system to produce actionable intelligence (Reference Annex B, Appendix 1, SANCHEZ). The Tiger Team concept should have only been used at Abu Ghraib for any high value targets identified. Those targets should receive careful planning and preparation, and be interrogated by the most experienced interrogators, analysts, and interpreters. Using a Tiger Team at Corps (the JIDC) for developing tactical intelligence did not work.

(4) (U) The JIDC is a non-doctrinal organization. Initially, there was no joint manning document for the JIDC (though one was developed by the 205 MI BDE over time and was submitted to CJTF-7). There was no approved structure for the JIDC. The manning document was being created as the JIDC was already operating (Reference Annex B, Appendix 1, WILLIAMS, Maurice). Because there is no JIDC doctrine (or training), procedures were ad hoc in nature – adapted from FM 34-52 where possible, though most processes and procedures were developed on the fly based upon the needs of the situation. The organization of the JIDC changed often (Reference Annex H, Appendix 6, Tab B) and contributed to the general state of turmoil at Abu Ghraib. Interrogators were not familiar with the new working arrangements (e.g., working with analysts) and were only slightly trained on the conduct of interrogations using translators. Note that most interrogators are only trained in conducting tactical interrogations in a conventional war environment (See paragraph 3.b.(3)). In spite of this turmoil, lack of training and doctrine, and shortages, the JIDC did mature over time and improved intelligence production derived from interrogations at Abu Ghraib.

(5) (U) Early in the formation of the JIDC, COL Pappas requested COL Boltz provide him with a Lieutenant Colonel to run the new organization because the responsibilities would require someone of that rank and commensurate experience. LTC Jordan had just arrived in Iraq four days earlier. He was originally sent to be COL Boltz's Deputy C2 but then a decision was made

SUBJECT: (U) AR 15-6 Investigation of the Abu Ghraib Detention Facility and
205th MI Brigade

to upgrade the C2 position from a COL to a MG. MG Fast was sent to CJTF-7 to be the C2, COL Boltz became the Deputy C2 and LTC Jordan became excess. Since LTC Jordan was available, COL Boltz assigned him to Abu Ghraib to run the JIDC. COL Boltz expected LTC Jordan to report to COL Pappas because COL Pappas had command responsibility for the JIDC. LTC Jordan was assigned to the JIDC verbally. He states that he never received orders (Reference Annex B, Appendix 1, JORDAN, BOLTZ).

(6) (U) There is a significant difference between what LTC Jordan claims he was told when he was sent to Abu Ghraib and what COL Pappas and COL Boltz say he was told. LTC Jordan says he was sent to be a "liaison" officer between CJTF-7 and the JIDC. COL Pappas and COL Boltz say he was sent there to be in charge of it. Reference to titles is useless as a way to sort through this because there was no actual manning document for reference; people made up their own titles as things went along. Some people thought COL Pappas was the Director; some thought LTC Jordan was the Director. A major shortcoming on the part of COL Pappas and LTC Jordan was the failure to do a formal Officer Evaluation Report (OER) support form, Department of Army (DA) Form 67-8-1, to clearly delineate LTC Jordan's roles and responsibilities. It is clear that both had their own ideas as to roles and responsibilities, and an initial goal-setting session formalized via the support form would have forced both parties to deal in specifics. Such sessions are frequently done after the fact; especially in stress-filled combat situations. The less organized the situation, however, the more such a process is needed in order to sort out the boundaries and lanes in the road. Abu Ghraib was certainly a place and a situation that required both clear boundaries and clear lanes in the road. LTC Jordan did provide a support form that he said he did some weeks after his assignment to Abu Ghraib and which he sent to COL Boltz. COL Boltz claims he never received it. LTC Jordan never received a signed copy back from COL Boltz and never followed up to get one. Even if LTC Jordan had sent the support form a few weeks later as he states, it was by then too late. The confusion/damage had been done. The early stages of the Abu Ghraib operation were the most critical to the disastrous end results (Reference Annex B, Appendix 1 BOLTZ, PAPPAS, JORDAN).

(7) (U) The preponderance of evidence supports the COLs Pappas/Boltz position that LTC Jordan was sent to run the JIDC. (Reference Annex B, Appendix 1, PAPPAS and BOLTZ). MAJ M. Williams, Operations Officer of the 205 MI BDE, and MAJ L. Potter, Deputy Commander of the 205 MI BDE, were adamant that LTC Jordan was sent for that reason. LTC Phillabaum believed LTC Jordan was in charge once he arrived at Abu Ghraib and started dealing directly with him. In all but one important aspect, interrogation operations, LTC Jordan began to act as if he were in charge.

(8) (U) As is now evident, LTC Jordan was a poor choice to run the JIDC. He was a Civil Affairs officer. He was an MI officer early in his career, but transferred to Civil Affairs in 1993. The MI experience he did have had not been in interrogation operations. LTC Jordan left the

SUBJECT: (U) AR 15-6 Investigation of the Abu Ghraib Detention Facility and
205th MI Brigade

actual management, organization, and leadership of the core of his responsibilities to MAJ Thompson and CPT Wood. The reality of the situation was that MAJ Thompson and CPT Wood were overwhelmed by the huge demands of trying to organize, staff, equip, and train the JIDC while at the same time answering incessant requests for information from both the 205 MI BDE as well as from CJTF-7. What the JIDC needed in the beginning, more than ever, was a trained, experienced MI LTC. COL Pappas was correct in his assessment of what was required. In the critical early stages of the JIDC, as it was being formed, Abu Ghraib needed a LTC to take total control. The need was for a leader to get the JIDC organized, to set standards, enforce discipline, create checks and balances, establish quality controls, communicate a zero tolerance for abuse of detainees, and enforce that policy by quickly and efficiently punishing offenders so that the rest of the organization clearly understood the message. Well-disciplined units that have active, involved leaders both at the NCO and Officer level are less likely to commit abuses or other such infractions. If such instances do occur, they are seldom repeated because those leaders act aggressively to deal with the violators and reemphasize the standards (Reference Annex B, Appendix 1, BOLTZ, PAPPAS, JORDAN).

(9) (U) LTC Jordan gravitated to what he knew, and what he was comfortable with, rather than filling the void noted above. He was actually a very hard working officer who dedicated himself to improving life for all of the Soldiers at Abu Ghraib. He is physically brave, volunteered for Iraq, and was wounded in action at Abu Ghraib during the mortar attack on 20 September 2003. He addressed shortcomings in the mess situation, lack of exercise equipment, protective gear, living conditions, and communications. He also enforced stricter adherence to the uniform policies and the wearing of protective gear by Soldiers and contractors. Many of the Soldiers that we spoke to, both MPs and MI, considered LTC Jordan the “go to guy” to get the types of things just enumerated done. BG Karpinski even remarked once to LTC Jordan during one of her visits “Do you ever sleep?” (Reference Annex B, Appendix 2, KARPINSKI). Unfortunately, all of the issues he was addressing should have been left to the staffs of the 205 MI BDE and the 320 MP BN. He was not the FOB Commander. LTC Phillabaum was the FOB Commander until the 19 November 2003 FRAGO. (Annex B, Appendix 1, JORDAN).

(10) (U) LTC Jordan became fascinated with the “Other Government Agencies,” a term used mostly to mean Central Intelligence Agency (CIA), who were operating at Abu Ghraib. The OGA “Ghost Detainee” issue (housing of detainees not formally accounted for) was well known within both the MI and MP communities and created a mystique about what “they” were doing (See paragraph 4.h.). LTC Jordan allowed OGA to do interrogations without the presence of Army personnel (Reference Annex B, Appendix 1, WOOD, THOMPSON, and PRICE). Prior to that time, JIDC policy was that an Army interrogator had to accompany OGA if they were interrogating one of the detainees MI was also interrogating. As noted above, LTC Jordan was little involved in the interrogation operations, but in this aspect he did become involved and it did not help the situation. The lack of OGA adherence to the practices and procedures

SUBJECT: (U) AR 15-6 Investigation of the Abu Ghraib Detention Facility and
205th MI Brigade

established for accounting for detainees eroded the necessity in the minds of Soldiers and civilians for them to follow Army rules.

(11) (U) LTC Jordan and ten other Soldiers were wounded in the mortar attack that occurred on 20 September 2003. Two Soldiers died in that attack. LTC Jordan was extremely traumatized by that attack, especially by the two deaths and the agony suffered by one of those Soldiers before his death. He was still very emotional about that attack when interviewed for this investigation on 27 May 2004. He said he thinks about the attack and the deaths daily. That attack also had an impact on a number of other Soldiers at Abu Ghraib as did the very frequent mortar attacks that occurred at Abu Ghraib during this entire period. The Soldiers' and civilians' morale at Abu Ghraib suffered as the attacks continued. Additionally, there was a general feeling by both MI and MP personnel that Abu Ghraib was the forgotten outpost receiving little support from the Army. (Reference Annex F, Appendix 3, Mortar Attacks). The frequency of these attacks and the perceived lack of aggressive action to prevent them were contributing factors to the overall poor morale that existed at Abu Ghraib.

(12) (U) COL Pappas perceived intense pressure for intelligence from interrogations. This began soon after he took Command in July 2003. In fact, as the time progressed from July 2003 through January 2004, interrogation operations at Abu Ghraib became the central focus of his efforts despite the fact that he was in command of the entire MI Brigade. That pressure for better results was passed from COL Pappas to the rest of the JIDC leadership (including MAJ Thompson, MAJ Price, CPT Wood, SOLDIER-23, and SOLDIER-14) and from them to the interrogators and analysts operating at Abu Ghraib. Pressure consisted in deviation from doctrinal reporting standards (pressure to report rapidly any and all information in non-standard formats such as Interrogator Notes in lieu of standard intelligence reports), directed guidance and prioritization from "higher," outside of doctrinal or standard operating procedures, to pursue specific lines of questioning with specific detainees, and high priority 'VFR Direct' taskings to the lowest levels in the JIDC. This pressure should have been expected in such a critical situation, but was not managed by the leadership and was a contributing factor to the environment that resulted in abuses. (Reference Annex B, Appendix 1, PAPPAS, BOLTZ, LYONS, WOOD, JORDAN, WILLIAMS, Maurice, POTTER, THOMAS, PRICE; and Annex B, Appendix 2, FAST, GEOFFREY MILLER, THOMAS MILLER).

(13) (U) The most critical period of time for Abu Ghraib was when COL Pappas committed a critical error in judgment by failing to remove LTC Jordan as soon as his shortcomings were noted, on approximately 10 October 2003. Very shortly after LTC Jordan's arrival at Abu Ghraib, on or about 17 September 2003, the 205 MI BDE Staff began to note LTC Jordan's involvement in staff issues and his lack of involvement in interrogation operations. The situation as described above would have been a daunting challenge for the most experienced, well trained, MI Officer. COL Pappas knew LTC Jordan was not who was needed to fulfill the JIDC

SUBJECT: (U) AR 15-6 Investigation of the Abu Ghraib Detention Facility and
205th MI Brigade

functions early on, but nevertheless chose to see if LTC Jordan could work out over time. COL Pappas made more frequent visits during this time period both because he was receiving increasing pressure for results but also because he could not rely on LTC Jordan to run the entire operation.

(14) (U) As pointed out clearly in the MG Taguba report, MP units and individuals at Abu Ghraib lacked sufficient training on operating a detainment/interrogation facility. MI units and individuals also lacked sufficient, appropriate, training to cope with the situation encountered at Abu Ghraib (See Paragraph 3.b.(4)). An insurgency is HUMINT intensive. The majority of that HUMINT comes from interrogations and debriefings. Yet at the JIDC, which was set up to be the focal point for interrogation operations, there was only one officer, CPT Wood, with significant interrogation operations experience. There were four MI Warrant Officers but all were used for staff functions rather than directly supervising and observing interrogations. There was a shortage of trained NCOs at the E-7/E-6 level. Each Section Leader had four or five Tiger Teams, too many to closely observe, critique, counsel, consult, and supervise. One Section Leader was an E-5. Several of the interrogators were civilians and about half of those civilians lacked sufficient background and training. Those civilians were allowed to interrogate because there were no more military assets to fill the slots. (Reference Annex B, Appendix 1, PAPPAS). Such a mixture together with constant demands for reports and documentation overwhelmed the Section Leaders. The analysts assigned to Tiger Teams were not all trained 96Bs, but were a mixture of all available intelligence Military Occupational Specialties (MOS). Many of those assigned as analysts had never been trained nor had they ever served as analysts.

(15) (U) Guard and interrogation personnel at Abu Ghraib were not adequately trained or experienced and were certainly not well versed in the cultural understanding of the detainees. MI personnel were totally ignorant of MP lanes in the road or rules of engagement. A common observation was that MI knew what MI could do and what MI couldn't do; but MI did not know what the MPs could or could not do in their activities. The same was true of MP ignorance of MI operational procedures. Having two distinct command channels (MI and MP – see Command and Control) in the same facility with little understanding of each other's doctrinal and regulatory responsibilities caused uncertainty and confusion. There was a perception among both MI and MP personnel that the other group was not doing its fair share in mutually supportive tasks of running the physical plant. CIVILIAN-12 (Assistant CJTF-7 C2X) observed that confusion seemed to be the order of the day at Abu Ghraib. There was hostility between MI and MP personnel over roles and responsibilities (Reference Annex B, Appendix 1, CIVILIAN-12). There was a distinct lack of experience in both camps. Except for some of the Reserve Component MPs who had civilian law enforcement experience, most of the MPs were never trained in prison operations. Because of the shortage of MPs, some MI personnel had to assume detainee escort duties, for which they received only the most rudimentary training.

SUBJECT: (U) AR 15-6 Investigation of the Abu Ghraib Detention Facility and
205th MI Brigade

(16) (U) Abu Ghraib rapidly evolved from a tactical interrogation operation in July 2003 to a JIDC beginning in September 2003. Doctrine, SOPs, and other tactics, techniques and procedures (TTP) for a JIDC were initially non-existent. The personnel manning the JIDC came from numerous units, backgrounds, and experiences. Equipment such as computers, software, IT infrastructure (networks, data storage), and connectivity to relevant intelligence data bases was very limited. Even file cabinets were in short supply which resulted in lost documents. One JIDC Soldier stated, "I can believe them (files for requests for exceptions to policy) getting lost because we often lost complete files. Our filing system was not the best. We did not have serviceable file cabinets and teams were given approval to place files in cardboard boxes." (Reference Annex B, Appendix 1, ADAMS) Initially there was only one computer available for every four interrogators. Ad hoc data bases were built, employed, and modified as requirements dictated. Data connectivity between interrogators and analysts was established using "thumb drives." Forms, intelligence products, and database formats came and went based upon their immediate utility – many times dictated by the changing structure of the JIDC itself as directed by leadership. Critical records regarding each detainee were located in several electronic and hardcopy locations – the operations officers maintained some files, others were maintained by section leaders, others by collection management personnel, and others by Detainee Release Board (DRB) personnel. Some interrogation related information was recorded on a whiteboard which was periodically erased. No centralized management system existed to manage interrogation operations. One result was that detainee records critical to the evaluation of prisoners for a variety of reasons (for intelligence value assessment, release, medical evaluation, etc.) were difficult to find or construct. MP records at Abu Ghraib were equally primitive. These documentation shortfalls not only hindered effective interrogation operations and information sharing, but also hindered the ability of the Security Internee Review and Appeal Board (which relied upon records reviews to make decisions to release or retain detainees). As addressed earlier, many detainees arrived at Abu Ghraib with little or no documentation from capturing units. Follow-on records maintained by the MP and MI personnel at Abu Ghraib would be sparse if the detainee had not been thoroughly interrogated. DRBs were reluctant to release a detainee if they knew little about him. MG Fast noted that one detainee file that was reviewed by the release board was completely empty. Even detainee medical records that should have been created and stored (Reference Annex H, Appendix 8) were not maintained appropriately. Medical doctors on site at Abu Ghraib claim that excellent medical records were maintained on detainees (Reference Annex B, Appendix 1, ACKERSON). Only a few detainee medical records could be found, indicating that they are not being maintained IAW AR 40-66 (Medical Records Administration and Healthcare Documentation).

g. (U) Contract Interrogators and Linguists

(1) (U) Contracting-related issues contributed to the problems at Abu Ghraib prison. Several of the alleged perpetrators of the abuse of detainees were employees of government

SUBJECT: (U) AR 15-6 Investigation of the Abu Ghraib Detention Facility and
205th MI Brigade

contractors. Two contractual arrangements were involved: one with CACI, for interrogators and several other intelligence - related occupational categories; and one with BTG, for linguists. Since 28 November 2001, BTG has been part of Titan Corporation. The contract is still in the name of BTG. Most people have referred to it as the Titan Contract. A brief description of these two contractual arrangements follows:

(a) (U) Linguist contract- Titan, Inc. - Contract DASC01-99-D-0001.

[1] (U) The need to supplement the Army's capacity for linguists was first raised to the Vice Chief of Staff of the Army in a 1997 "Foreign Language Lay down." It was proposed to establish a contract with the private sector to provide linguists, as needed, for contingencies and current intelligence operations.

[2] (U) As a result of this perceived need, INSCOM awarded Contract DASC01-99-D-0001 to Titan, in March 1999. The contract called for Titan initially to develop a plan to provide and manage linguists throughout the world, and later, implement the plan as required. The contract called for three levels of linguists- some were required to obtain security clearances and some were not. The linguist candidates were subject to some level of background investigations, based on individual requirements for security clearances. Since the award of the contract, hundreds of linguists have been provided, with generally positive results. It is noted that the contract calls for translation services only, and makes no mention of contractor employees actually conducting interrogations. Since the statement of work is limited to translation services, the linguists apparently were not required to review and sign the IROE at Abu Ghraib. A recent review of the contract indicated that the current contract ceiling is approximately \$650 Million. Other agencies can order linguist services under this contract. For the most part, the ordering activity also provides the funds for these delivery orders. The contract contains a clause that allows the Contracting Officer to direct the contractor to remove linguists from the theater in which they are performing. This clause has been invoked on occasion for misconduct.

(b) Interrogator contract-CACI, Inc.

[1] (U) The second contractual arrangement is a series of Delivery Orders awarded to CACI, in August 2003, which call for the provision of numerous intelligence-related services such as "Interrogator Support," "Screening Cell Support," "Open Source Intelligence," "Special Security Office," "HUMINT Augmentee Contractors" (which includes "Interrogation Support," "Junior Interrogators," "Senior and Junior Counter-Intelligence Agents," and "Tactical/Strategic Interrogators").

SUBJECT: (U) AR 15-6 Investigation of the Abu Ghraib Detention Facility and
205th MI Brigade

[2] (U) These Delivery Orders were awarded under a Blanket Purchase Agreement (BPA) (NBCHA01-0005) with the National Business Center (NBC), a fee for service activity of the Interior Department. The BPA between CACI and NBC set out the ground rules for ordering from the General Services Administration (GSA) pursuant to GSA Schedule Contract GS-35F-5872H, which is for various Information Technology (IT) Professional Services. Approximately eleven Delivery Orders were related to services in Iraq. While CJTF-7 is the requiring and funding activity for the Delivery Orders in question, it is not clear who, if anyone, in Army contracting or legal channels approved the use of the BPA, or why it was used.

[3] (U) There is another problem with the CACI contract. A CACI employee, Thomas Howard, participated with the COR, LTC Brady, in writing the Statement of Work (SOW) prior to the award of the contract (Reference Annex B, Appendix 1, BOLTZ). This situation may violate the provisions of Federal Acquisition Regulation (FAR) 9. 505-2 (b) (1).

[4] (U) On 13 May 2004, the Deputy General Counsel (Acquisition) of the Army issued an opinion that all Delivery Orders for Interrogator Services should be cancelled immediately as they were beyond the scope of the GSA Schedule contract.

(2) (U) Although intelligence activities and related services, which encompass interrogation services, should be performed by military or government civilian personnel wherever feasible, it is recognized that contracts for such services may be required in urgent or emergency situations. The general policy of not contracting for intelligence functions and services was designed in part to avoid many of the problems that eventually developed at Abu Ghraib, i.e., lack of oversight to insure that intelligence operations continued to fall within the law and the authorized chain of command, as well as the government's ability to oversee contract operations.

(3) (U) Performing the interrogation function in-house with government employees has several tangible benefits for the Army. It enables the Army more readily to manage the function if all personnel are directly and clearly subject to the chain of command, and other administrative and/or criminal sanctions, and it allows the function to be directly accessible by the commander/supervisor without going through a Contracting Officer Representative (COR). In addition, performing the function in-house enables Army Commanders to maintain a consistent approach to training (See Paragraph 3.b.(3)) and a reliable measure of the qualifications of the people performing the function.

(4) (U) If it is necessary to contract for interrogator services, Army requiring activities must carefully develop the applicable SOW to include the technical requirements and requisite personnel qualifications, experience, and training. Any such contracts should, to the greatest extent possible, be awarded and administered by an Army contracting activity in order to provide for the necessary oversight, management, and chain of command. Use of contracting vehicles

SUBJECT: (U) AR 15-6 Investigation of the Abu Ghraib Detention Facility and
205th MI Brigade

such as GSA Federal Supply Schedule (FSS) contracts should be carefully scrutinized given the complexity and sensitivities connected to interrogation operations.

(5) (U) Some of the employees at Abu Ghraib were not DoD contractor employees. Contractor employees under non-DoD contracts may not be subject to the Military Extraterritorial Jurisdiction Act (18 US Code 3261- 3267). The Act allows DoD contractor employees who are “accompanying the Armed Forces outside the United States” to be subject to criminal prosecution if they engage in conduct that would constitute an offense punishable by imprisonment for more than one year if the conduct had occurred within the jurisdiction of the United States.

(6) (U) In the performance of such sensitive functions as interrogation, the Army needs to maintain close control over the entire operation. If a decision is made to contract for these services, the most effective way to do that and maintain a direct chain of command is to award, administer, and manage the contract with Army personnel. As learned in the current situation, it is very difficult, if not impossible, to effectively administer a contract when the COR is not on site.

(7) (U) The Army needs to improve on-site contract monitoring by government employees (using CORs) to insure that the Army’s basic interests are protected. The inadequacy of the on-site contract management at Abu Ghraib is best understood by reviewing the statement of CPT Wood (Reference Annex B, Appendix 1, WOOD), the Interrogation OIC, who indicated she never received any parameters or guidance as to how the CACI personnel were to be utilized. She also indicates that her primary point of contact (POC) on matters involving the CACI Delivery Orders was the CACI on-site manager. There is no mention of a COR. Another indication of the inadequacy of the contract management is reflected in the statement of SOLDIER14 (Reference Annex B, Appendix 1, SOLDIER-14), who indicated he was never informed that the Government could reject unsatisfactory CACI employees. It would appear that no effort to familiarize the ultimate user of the contracted services of the contract’s terms and procedures was ever made. In order to improve this situation, training is required to ensure that the COR is thoroughly familiar with the contract and gains some level of familiarity with the Geneva Conventions standards. It needs to be made clear that contractor employees are bound by the requirements of the Geneva Conventions.

(8) (U) If it is necessary to contract for interrogator services, more specific training requirements and personnel standards must be incorporated into the solicitation/contract to insure that the contractor hires properly trained and qualified personnel.

(9) (U) Emerging results from a DA Inspector General (DAIG) Investigation indicate that approximately 35% of the contract interrogators lacked formal military training as interrogators.

SUBJECT: (U) AR 15-6 Investigation of the Abu Ghraib Detention Facility and
205th MI Brigade

While there are specific technical requirements in the linguist contract, the technical requirements for the interrogator contract were not adequate. It appears that the only mention of qualifications in the contract stated merely that the contractor employee needs to have met the requirements of one of two MOS, 97E or 351E, or "equivalent". Any solicitation/contract for these services needs to list specific training, if possible, not just point to an MOS. If the training from the MOS is what is required, those requirements should be listed in the solicitation/contract in full, not just referenced. Perhaps the best way of insuring that contractor interrogators receive adequate training would be to utilize existing government training. For example, prospective contractor employees could be sent, at contractor expense, to the Tactical Human Intelligence Course for the 97E MOS, "Human Intelligence Collector." Such a step would likely require some adjustments to the current program of instruction. Prospective contract interrogators could be given the course tests on Interrogation and the Geneva Conventions. If they can pass the examinations, no further training would be required. After a reasonable training period, prospective contractor interrogators who are unable to pass the exam would be rejected. There are, of course other training possibilities. The key point would be agreement on some standardization of the training of contractor interrogators. The necessity for some sort of standard training and/or experience is made evident by the statements of both contractor employees and military personnel. CIVILIAN-21 (CACI) seemingly had little or no interrogator experience prior to coming to Abu Ghraib (Reference Annex B, Appendix 1, CIVILIAN-21, ADAMS), even though he was a Navy Reserve Intelligence Specialist. Likewise, numerous statements indicated that little, if any, training on Geneva Conventions was presented to contractor employees (Reference Annex B, Appendix 1, SOLDIER-25, CIVILIAN-10, CIVILIAN-21 and CIVILIAN-11). Prior to deployment, all contractor linguists or interrogators should receive training in the Geneva Conventions standards for the treatment of detainees/prisoners. This training should include a discussion of the chain of command and the establishment of some sort of "hotline" where suspected abuses can be reported in addition to reporting through the chain of command. If the solicitation/contract allows "equivalent" training and experience, the Contracting Officer, with the assistance of technical personnel, must evaluate and assess the offerors'/contractor's proposal/written rationale as to why it believes that the employee has "equivalent" training. It appears that under the CACI contract, no one was monitoring the contractor's decisions as to what was considered "equivalent."

(10) (U) In addition, if functions such as these are being contracted, MI personnel need to have at least a basic level of contract training so they can protect the Army's interests. Another indication of the apparent inadequacy of on-site contract management and lack of contract training is the apparent lack of understanding of the appropriate relationship between contractor personnel, government civilian employees, and military personnel. Several people indicated in their statements that contractor personnel were "supervising" government personnel or *vice versa*. SGT Adams indicated that CACI employees were in positions of authority, and appeared to be supervising government personnel. She indicated a CACI employee named "First Name"

SUBJECT: (U) AR 15-6 Investigation of the Abu Ghraib Detention Facility and
205th MI Brigade

was listed as being in charge of screening. CIVILIAN-08 (CACI) was in charge of “B Section” with military personnel listed as subordinates on the organization chart. SOLDIER-14 also indicated that CIVILIAN-08 was a supervisor for a time. CPT Wood stated that CACI “supervised” military personnel in her statement, but offered no specifics. Finally, a government organization chart (Reference Annex H, Appendix 6, Tab B) showed a CIVILIAN-02 (CACI) as the Head of the DAB. CIVILIAN-02 is a CACI employee. On the other side of the coin, CIVILIAN-21 indicated in his statement that the Non-Commissioned Officer in Charge (NCOIC) was his supervisor. (Reference Annex B, Appendix 1, SOLDIER-14, CIVILIAN-21, ADAMS, WOOD)

(11) (U) Given the sensitive nature of these sorts of functions, it should be required that the contractor perform some sort of background investigation on the prospective employees. A clause that would allow the government to direct the contractor to remove employees from the theater for misconduct would seem advisable. The need for a more extensive pre-performance background investigation is borne out by the allegations of abuse by contractor personnel.

(12) (U) An important step in precluding the recurrence of situations where contractor personnel may engage in abuse of prisoners is to insure that a properly trained COR is on-site. Meaningful contract administration and monitoring will not be possible if a small number of CORs are asked to monitor the performance of one or more contractors who may have 100 or more employees in the theater, and in some cases, perhaps in several locations (which seems to have been the situation at Abu Ghraib). In these cases, the CORs do well to keep up with the paper work, and simply have no time to actively monitor contractor performance. It is apparent that there was no credible exercise of appropriate oversight of contract performance at Abu Ghraib.

(13) (U) Proper oversight did not occur at Abu Ghraib due to a lack of training and inadequate contract management and monitoring. Failure to assign an adequate number of CORs to the area of contract performance puts the Army at risk of being unable to control poor performance or become aware of possible misconduct by contractor personnel. This lack of monitoring was a contributing factor to the problems that were experienced with the performance of the contractors at Abu Ghraib. The Army needs to take a much more aggressive approach to contract administration and management if interrogator services are to be contracted. Some amount of advance planning should be utilized to learn from the mistakes made at Abu Ghraib.

h. (U) Other Government Agencies and Abu Ghraib.

(1) (U) Although the FBI, JTF-121, Criminal Investigative Task Force, ISG and the Central Intelligence Agency (CIA) were all present at Abu Ghraib, the acronym “Other Government Agency” (OGA) referred almost exclusively to the CIA. CIA detention and interrogation

SUBJECT: (U) AR 15-6 Investigation of the Abu Ghraib Detention Facility and
205th MI Brigade

practices led to a loss of accountability, abuse, reduced interagency cooperation, and an unhealthy mystique that further poisoned the atmosphere at Abu Ghraib.

(2) (U) CIA detainees in Abu Ghraib, known locally as “Ghost Detainees,” were not accounted for in the detention system. When the detainees were unidentified or unaccounted for, detention operations at large were impacted because personnel at the operations level were uncertain how to report them or how to classify them, or how to database them, if at all. Therefore, Abu Ghraib personnel were unable to respond to requests for information about CIA detainees from higher headquarters. This confusion arose because the CIA did not follow the established procedures for detainee in-processing, such as fully identifying detainees by name, biometric data, and Internee Serial Number (ISN) number.

(3) (U) DETAINEE-28, suspected of having been involved in an attack against the ICRC, was captured by Navy SEAL Team 7 during a joint TF-121/CIA mission. He reportedly resisted arrest, so a SEAL Team member butt-stroked DETAINEE-28 on the side of the head to subdue him. CIA representatives brought DETAINEE-28 into Abu Ghraib early in the morning of 4 November 2003, sometime around 0430 to 0530 hours. Under a supposed verbal agreement between the JIDC and the CIA, the CIA did not announce its arrival to JIDC Operations. SPC Stevanus, the MP on duty at the Hard Site at the time, observed the two CIA representatives come in with DETAINEE-28 and place him in a shower room in Tier 1B. About 30 to 45 minutes later, SPC Stevanus was summoned to the shower stall and when he arrived, DETAINEE-28 appeared to be dead. Removing the sandbag covering DETAINEE-28’s head, SPC Stevanus checked DETAINEE-28’s pulse. Finding none, he called for medical assistance, and notified his chain of command. LTC Jordan arrived on site at approximately 0715 hours, and found several MPs and US medical staff with DETAINEE-28 in the Tier 1B shower stall, face down, handcuffed with his hands behind his back. CIVILIAN-03, an Iraqi prison medical doctor, informed him DETAINEE-28 was dead. "OTHER AGENCY EMPLOYEE01," a CIA representative, un-cuffed DETAINEE-28 and turned his body over. Where DETAINEE-28’s head had lain against the floor, LTC Jordan noted a small spot of blood. LTC Jordan notified COL Pappas (205 MI BDE Commander), and "OTHER AGENCY EMPLOYEE01" said he would notify “OTHER AGENCY EMPLOYEE02,” his CIA supervisor. Once "OTHER AGENCY EMPLOYEE02" arrived, he requested that the Hard Site hold DETAINEE28’s body until the following day. DETAINEE-28’s body was placed in a body bag, packed in ice, and stored in the shower area. CID was notified. The next day, DETAINEE-28’s body was removed from Abu Ghraib on a litter, to make it appear as if he were only ill, so as not to draw the attention of the Iraqi guards and detainees. The body was transported to the morgue at BIAP for an autopsy, which concluded that DETAINEE-28 died of a blood clot in the head, likely a result of injuries he sustained during apprehension. (Reference Annex B, Appendix 1, JORDAN, PAPPAS, PHILLABAUM, SNIDER, STEVANUS, THOMPSON; Annex I, Appendix 1, photographs C5-21, D5-11, M65-69)

SUBJECT: (U) AR 15-6 Investigation of the Abu Ghraib Detention Facility and
205th MI Brigade

(4) (U) The systemic lack of accountability for interrogator actions and detainees plagued detainee operations in Abu Ghraib. It is unclear how and under what authority the CIA could place prisoners like DETAINEE-28 in Abu Ghraib because no memorandums of understanding existed on the subject between the CIA and CJTF-7. Local CIA officers convinced COL Pappas and LTC Jordan that they should be allowed to operate outside the established local rules and procedures. When COL Pappas raised the issue of CIA use of Abu Ghraib with COL Boltz, COL Boltz encouraged COL Pappas to cooperate with the CIA because everyone was all one team. COL Boltz directed LTC Jordan to cooperate. (Reference Annex B, Appendix 1, PAPPAS, BOLTZ)

(5) (U) In many instances, failure to adhere to in-processing procedures caused confusion and acrimony between the Army and OGA, and in at least one instance, acrimony between the US and Saudi Arabian entities. (Reference Annex K, Appendix 3, emails) For example, the CIA interned three Saudi national medical personnel working for the coalition in Iraq. CIA officers placed them in Abu Ghraib under false names. The Saudi General in charge of the men asked US authorities to check the records for them. A search of all databases using their true names came back negative. Ambassador Bremer then requested a search, which produced the same results. The US Embassy in Riyadh also requested a search, which likewise produced no information. Ultimately, the Secretary of State, Colin Powell, requested a search, and as with the other requestors, had to be told that the three men were not known to be in US custody. Shortly after the search for the Secretary of State, a JIDC official recalled that CIA officers once brought three men together into the facility. A quick discussion with the detainees disclosed their true names, which matched the name search requests, and the men were eventually released. (Reference Annex B, Appendix 1, CIVILIAN-12)

(6) (U) Another instance showing lack of accountability to the procedures or rules involved a CIA officer who entered the interrogation room after a break in the interrogation, drew his weapon, chambered a round, and placed the weapon in his holster. This action violated the rule that no weapons be brought into an interrogation room, especially weapons with live rounds. Detainees who have been interrogated by CIA officers have alleged abuse. (Reference Annex B, Appendix 1, CIVILIAN-12)

(7) (U) The death of DETAINEE-28 and incidents such as the loaded weapon in the interrogation room, were widely known within the US community (MI and MP alike) at Abu Ghraib. Speculation and resentment grew over the lack of personal responsibility, of some people being above the laws and regulations. The resentment contributed to the unhealthy environment that existed at Abu Ghraib. The DETAINEE-28 death remains unresolved. CIA officers operating at Abu Ghraib used alias' and never revealed their true names. "OTHER AGENCY EMPLOYEE01" (alias) was the CIA officer with DETAINEE-28 on the morning of

SUBJECT: (U) AR 15-6 Investigation of the Abu Ghraib Detention Facility and
205th MI Brigade

his death. "OTHER AGENCY EMPLOYEE02" (alias) was not directly involved in DETAINEE-28's death, but participated in the discussions after his death. Had the CIA followed established Army procedures and in-processed DETAINEE-28 in accordance with those procedures, DETAINEE-28 would have been medically screened.

(8) (U) OGA never provided results of their abuse investigations to Commander, CJTF-7. This resulted in a total lack of visibility over OGA interaction with detainees held in CJTF-7 spaces. Additionally, the CJTF-7 charter provided no oversight or control over the ISG. LTG Sanchez could neither leverage ISG interrogation assets to assist the detainee operations in Abu Ghraib, nor could he compel ISG to share substantive intelligence reports with CJTF-7. (Reference Annex B, Appendix 1, SANCHEZ)

i. (U) The Move of the 205 MI BDE Commander to Abu Ghraib.

(1) (U) In September 2003, COL Pappas began visiting Abu Ghraib two or three times per week as opposed to once every week or two, his previous routine. He was also beginning to stay overnight occasionally. His visit schedule coincided with the increased emphasis being placed on interrogation operations and the newly formed JIDC. (Reference Annex B, Appendix 1, PAPPAS)

(2) (U) On 16 November 2003, COL Pappas took up full time residence at Abu Ghraib after once again speaking with LTG Sanchez and MG Fast and deciding that he needed to be there. He was appointed FOB Commander on 19 November 2003 in FRAGO 1108. The issuance of FRAGO 1108 has been pointed to and looked upon by many as being a significant change and one that was a major factor in allowing the abuses to occur. It was not. The abuses and the environment for them began long before FRAGO 1108 was ever issued. That FRAGO appointed the Commander, 205 MI BDE, the Commander FOB Abu Ghraib for Force Protection and Security of Detainees. COL Pappas then had TACON of the 320 MP BN. TACON has been misinterpreted by some to mean that COL Pappas then took over the running of the prison, or what has been referred to as Warden functions. COL Pappas never took over those functions, and LTC Phillabaum agrees that the running of the prison was always his responsibility. LTG Sanchez has stated that he never intended to do anything except improve the Force Protection posture of the FOB. That improved force protection posture would have thus improved the security of detainees as well. COL Pappas' rater, MG Wojdakowski, also stated that COL Pappas was never given responsibility for running the prison, but that the MPs retained that responsibility. It would appear from MG Taguba's investigation and the interview for this investigation that BG Karpinski was the only person among the Army leadership involved at the time who interpreted that FRAGO differently. (Reference Annex B, Appendix 1, KARPINSKI and Annex B, Appendix 2, KARPINSKI)

SUBJECT: (U) AR 15-6 Investigation of the Abu Ghraib Detention Facility and
205th MI Brigade

(3) (U) Upon being appointed FOB Commander, COL Pappas brought in one of his subordinate units, the 165th MI Battalion (165 MI BN) to enhance base security and to augment forces providing perimeter security as well as to conduct reconnaissance and surveillance outside the perimeter. That unit had reconnaissance and surveillance elements similar to line combat units that the MP Battalions did not possess. COL Pappas, on 8 December 2003, requested additional forces to support his force protection mission (Reference Annex H, Appendix 6, TAB – Request for Forces (RFF)). Requested forces included personnel for additional guards and a rapid reaction force.

(4) (U) The fact that COL Pappas did not have control of the MP force after the 19 November 2003 FRAGO regarding prison operations is further supported by the fact that at some point near the end of November 2003, the MPs stopped escorting detainees from the camps to the interrogation sites due to personnel shortages. This required MI to take over this function despite their protests that they were neither trained nor manned to do it. COL Pappas would have ordered the MPs to continue the escorts if he had had such authority (See paragraph 4.c.)

(5) (U) A milestone event at Abu Ghraib was the shooting incident that occurred in Tier 1A on 24 November 2003 (See paragraph 5.e.). COL Pappas was by then in residence at Abu Ghraib. LTC Jordan displayed personal bravery by his direct involvement in the shoot-out, but also extremely poor judgment. Instead of ordering the MPs present to halt their actions and isolate the tier until the 320 MP BN Commander and COL Pappas could be notified, he became directly involved. As the senior officer present, LTC Jordan became responsible for what happened. Eventually, COL Pappas was notified, and he did visit the scene. By then the shooting was over, and the MPs were searching the cells. COL Pappas did not remain long but admits to being told by SOLDIER-23 that the Iraqi Police were being interrogated by MI personnel. COL Pappas left LTC Jordan in charge of the situation after the shooting which came to be known as the IP Roundup. The IP Roundup was, by all accounts chaotic. The Iraqi Police, hence the name “IP,” became detainees and were subjected to strip searching by the MPs in the hallway, with female Soldiers and at least one female interpreter present. The IP were kept in various stages of dress, including nakedness, for prolonged periods as they were interrogated. This constitutes humiliation, which is detainee abuse. Military working dogs were being used not only to search the cells, but also to intimidate the IPs during interrogation without authorization. There was a general understanding among the MI personnel present that LTG Sanchez had authorized suspending existing ICRP (known by the Abu Ghraib personnel locally as the IROE) because of the shooting (Reference Annex C, Appendix 1, Tab B, Annex 8, AR 15-6 Investigation, 24 November 2003). Nobody is sure where that information came from, but LTG Sanchez never gave such authorization (Reference Annex B, Appendix 1, SANCHEZ). LTC Jordan and the Soldiers should have known the Interrogation Rules would not and could not have been suspended. LTC Jordan should have controlled the situation and should have taken steps to reinforce proper standards at a time when emotions were likely high given the

SUBJECT: (U) AR 15-6 Investigation of the Abu Ghraib Detention Facility and
205th MI Brigade

circumstances. LTC Jordan is responsible for allowing the chaotic situation, the unauthorized nakedness and resultant humiliation, and the military working dog abuses that occurred that night. LTC Jordan should have obtained any authorizations to suspend ICRP in writing, via email, if by no other means. The tone and the environment that occurred that night, with the tacit approval of LTC Jordan, can be pointed to as the causative factor that set the stage for the abuses that followed for days afterward related to the shooting and the IP Roundup. COL Pappas is also responsible and showed poor judgment by leaving the scene before normalcy returned, as well as for leaving LTC Jordan in charge.

(6) (U) The small quantity of MI personnel had a difficult time managing the large number of MI holds which moved from the hundreds to over a thousand by December 2003 (See paragraph 4.c.(12)). In December 2003, COL Pappas, in his role as FOB Commander, requested additional forces be allocated to support the difficult and growing force protection mission. Prior to his designation as FOB Commander, COL Pappas had requested additional forces to support the JIDC mission. One of the reasons he cited in the December request was that the mixing of MI and MP functions was worsening the already difficult personnel resource situation.

j. (U) Advisory and Training Team Deployments

(1) (U) MG Geoffrey Miller Visit

(a) (U) MG G. Miller's visit was in response to a J3, JCS, request to SOUTHCOM for a team to assist CENTCOM and ISG in theater (Reference Annex L, Appendix 1, Electrical Message, DTG: 181854Z Aug 03, FM JOINT STAFF WASHINGTON DC // J3). The team was directed to assist with advice on facilities and operations specific to screening, interrogations, HUMINT collection, and interagency integration in the short and long term. MG G. Miller was tasked as the result of a May 2003 meeting he had with MG Ronald Burgess, J2, JCS. MG Burgess indicated there were some challenges in CJTF-7 with the transition from major combat operations to SASO in the areas of intelligence, interrogation, and detention (Reference Annex B, Appendix 1, MILLER). COL Boltz believed LTG Sanchez had requested the support (Reference Annex B, Appendix 1, BOLTZ).

(b) (U) From 31 August to 9 September 2003, MG G. Miller led a team to Iraq to conduct an "Assessment of DoD Counterterrorism Interrogation and Detention Operations in Iraq." Specifically, MG G. Miller's team was to conduct assistance visits to CJTF-7, TF-20, and the ISG to discuss current theater ability to exploit internees rapidly for actionable intelligence. MG G. Miller and his team of 17 experts assessed three major areas of concern: intelligence integration, synchronization, and fusion; interrogation operations; and detention operations. The team's assessment (Reference Annex L, Appendix 1, MG Miller's Report, Assessment of DoD Counterterrorism Interrogation and Detention Operations in Iraq, undated, and MG Miller's

SUBJECT: (U) AR 15-6 Investigation of the Abu Ghraib Detention Facility and
205th MI Brigade

Briefing of his findings, dated 6 September 2003) identified several areas in need of attention: the interrogators didn't have the authorities and procedures in place to effect a unified strategy to detain, interrogate, and report information from detainees in Iraq; the information needs required an in-theater analysis capability integrated in the interrogation operations to allow for access/leverage of the worldwide intelligence databases; and the detention operations function must support the interrogation process.

(c) (U) MG G. Miller's visit also introduced written GTMO documentation into the CJTF-7 environment. LTG Sanchez recalled MG G. Miller left behind a whole series of SOPs that could be used as a start point for CJTF-7 interrogation operations. It was clear that these SOPs had to be adapted to the conditions in Iraq and that they could not be implemented blindly. LTG Sanchez was confident the entire CJTF-7 staff understood that the conditions in GTMO were different than in Iraq, because the Geneva Conventions applied in the Iraqi theater.

(d) (U) The assessment team essentially conducted a systems analysis of the intelligence mission in Iraq and did not concentrate on specific interrogation techniques. While no "harsh techniques" were briefed, COL Pappas recalled a conversation with MG G. Miller regarding the use of military working dogs to support interrogations (See paragraph 5.f.). According to COL Pappas, MG G. Miller said they, GTMO, used military working dogs, and that they were effective in setting the atmosphere for interrogations (Reference Annex B, Appendix 2, PAPPAS). MG G. Miller contradicted COL Pappas in his statement (Reference Annex B, Appendix 1, MILLER), saying he only discussed using military working dogs to help the MPs with detainee custody and control issues. According to MG G. Miller, the dogs help provide a controlled atmosphere (not interrogations as recalled by COL Pappas) that helps reduce risk of detainee demonstrations or acts of violence. According to MG G. Miller, his team recommended a strategy to work the operational schedule of the dog teams so the dogs were present when the detainees were awake, not when they are sleeping.

(e) (U) Several things occurred subsequent to MG G. Miller's visit to Abu Ghraib. The JIDC was established. The use of Tiger Teams was implemented based on the JTF-GTMO model, which teamed an interrogator and an analyst together, giving each team an organic analytical capability. There was also a moderate increase in the number of interrogators reassigned to the Abu Ghraib operation. This increase was probably not connected to MG G. Miller's visit as much as to the arrival of elements of the 325 MI BN which began to arrive 10 September 2003--the same day MG G. Miller departed Iraq. Prior to their arrival, the interrogation assets consisted of one OIC (captain), one technician (chief warrant officer), 12 HUMINT collectors (MOS 97E/97B), an analyst, and a communications team. While the number of interrogators increased, the JIDC requirements for a staff and leadership also increased. Those positions were filled from within the assigned units. It is indeterminate what impact the MG G. Miller Team's concepts had on operations at Abu Ghraib. There was an

SUBJECT: (U) AR 15-6 Investigation of the Abu Ghraib Detention Facility and
205th MI Brigade

increase in intelligence reports after the visit but that appears more likely due to the assignment of trained interrogators and an increased number of MI Hold detainees to interrogate.

(2) JTF-GTMO Training Team.

(a) (U) Subsequent to MG G. Miller's visit, a team of subject matter experts was dispatched from JTF-GTMO to Abu Ghraib (approximately 4 October to 2 December 2003) to assist in the implementation of the recommendations identified by MG G. Miller. The JTF-GTMO Team included three interrogators and three analysts, organized into three teams, with one interrogator and one analyst on each, which is the GTMO "Tiger Team" concept. The JTF GTMO Team included SOLDIER28 (351E Team Chief), SOLDIER27, CIVILIAN-14 (97E), SOLDIER-03 (97E), SSG Miller (96B), and SOLDIER-11 (96B). The Team Chief understood his task was to assist CJTF-7 for a period not to exceed 90 days with the mission of building a robust and effective JIDC, and identifying solutions and providing recommendations for the JIDC (Reference Annex B, Appendix 1, SOLDIER-28). Upon arrival at Abu Ghraib, SOLDIER-28 and SOLDIER-27, both of whom had been on the original MG G. Miller assessment visit, concentrated on establishing the various JIDC elements. Particular emphasis was given to formalizing the JIDC staff and the collection, management and dissemination (CM&D) function at Abu Ghraib, to alleviate many of the information distribution issues surfaced during MG G. Miller's visit. Some interrogation policies were already in place. Consistent with its charter to assist in establishment of a GTMO-like operation, the team provided copies of the current JTF-GTMO policies, SOPs (Reference, Annex L, Appendix 2, SOP for JTF-GTMO, Joint Intelligence Group [JIG], Interrogation Control Element [ICE], Guantanamo Bay, CU, dated 21 January 2003, revised 12 June 2003), and the SECDEF Letter (Reference, Annex J, Appendix 2, MEMORANDUM FOR COMMANDER, US SOUTHERN COMMAND, Subject: Counter-Resistance Techniques in the War on Terrorism (S), dated 16 April 2003) outlining the techniques authorized for use with the GTMO detainees. The four other JTF-GTMO team members were split up and integrated into interrogation operations as members/leaders of the newly formed Tiger Teams under the ICE. SOLDIER-28 and SOLDIER-27 did not directly participate in any interrogation operations and reported that they never observed, or heard about, any detainee abuse or mistreatment. SOLDIER-28's assertion as regards knowledge of abuses is contradicted by one of his Soldiers (Reference Annex B, Appendix 1, SOLDIER-03) (See paragraphs 4.j.(2)(c) and 4.j.(2)(d), below).

(b) (U) While the JTF-GTMO team's mission was to support operations and assist in establishment of the JIDC, there was a great deal of animosity on the part of the Abu Ghraib personnel, especially some A/519 MI BN Personnel. This included an intentional disregard for the concepts and techniques the GTMO Team attempted to instill, as well as contempt for some of the team's work ethic, professional judgment, and ideas. Because of this, the GTMO Team's ability to effect change at Abu Ghraib may have been severely limited. This information was

SUBJECT: (U) AR 15-6 Investigation of the Abu Ghraib Detention Facility and
205th MI Brigade

obtained during a review of email exchanged between SOLDIER-14, CW2 Grace, CW3 Sammons, SFC McBride, with info copies to CPT Wood and SOLDIER-23. It should be noted that senior managers at Abu Ghraib thought highly of the JTF-GTMO team and believed they positively impacted the operations.

(c) (U) SOLDIER-11, a JTF-GTMO analyst assigned to the "Former Regime Loyalists" Tiger Team, stated that he witnessed and reported two incidents of abuse (Reference Annex B, Appendix 1, SOLDIER-11). In his first report, SOLDIER-11 reported that he was observing an interrogation being conducted by SOLDIER-19 A/519 MI BN. As SOLDIER-11 observed from behind a glass, SOLDIER-19 directed a detainee to roll his jumpsuit down to his waist and insinuated that the detainee would be stripped further if he did not cooperate. The interrogation ended abruptly when the translator objected to the tactic and refused to continue. SOLDIER-11 reported the incident to both SOLDIER-16, his Tiger Team Leader, and to SOLDIER-28, his JTF GTMO Team Chief. SOLDIER-16 invoked her rights under UCMJ and chose not to make any statement regarding this or any other matters (Reference Annex B, Appendix 1, SOLDIER-16). When asked, SOLDIER-28 stated that he could not recall what SOLDIER-11 reported to him regarding the rolling down of the detainee's jumpsuit, but does recall a conversation about a translator walking out of an interrogation due to a "cultural difference" (Reference Annex B, Appendix 1, SOLDIER-28). SOLDIER-11 is adamant that he reported the incident in detail (Reference Annex B, Appendix 1, SOLDIER-11) and that he never used the phrase "cultural difference."

(d) (U) In another report to SOLDIER-28, SOLDIER-11 reported a second incident. SOLDIER-11 and SOLDIER-19 were conducting an interrogation around mid-October 2003. The detainee was uncooperative and was not answering questions. SOLDIER-19 became frustrated and suggested to SOLDIER-11 that the detainee be placed in solitary. SOLDIER-11 did not agree with the recommendation and suggested it would be counterproductive. About 15 minutes later (two hours into the interrogation), SOLDIER-19 exercised his authority as the lead interrogator and had the detainee placed in solitary confinement. About a half an hour later, SOLDIER-11 and SOLDIER-19 went to the Hard Site to see the detainee, and found him lying on the floor, completely naked except for a hood that covered his head from his upper lip, whimpering. SOLDIER-11 and SOLDIER-19 had the MPs redress the detainee before escorting him back to the general population. SOLDIER-11 was disturbed by what he had seen and considered reporting it to several different people. Ultimately, SOLDIER-11 reported this incident to SOLDIER-28 (Reference Annex B, Appendix 1, SOLDIER-11). SOLDIER-11 added that SOLDIER-28 accepted the report and indicated he would surface the issue to COL Pappas (not due to return to Abu Ghraib for 2 - 3 days). Also according to SOLDIER-11, SOLDIER-28 was very ill and placed on 30 days quarters shortly after SOLDIER-11 made his report. When asked, SOLDIER-28 could not recall such a report being made to him (Reference Annex B, Appendix 1, SOLDIER-28).

SUBJECT: (U) AR 15-6 Investigation of the Abu Ghraib Detention Facility and
205th MI Brigade

(e) (U) SSG Miller does not recall the JTF-GTMO team ever discussing specific interrogation techniques employed, abuse, or unauthorized interrogation methods. He observed only approved interrogation techniques in line with FM 34-52, and never saw any detainee abuse, mistreatment, or nakedness (Reference Annex B, Appendix 1, MILLER).

(f) (U) CIVILIAN-14 never observed any activity or training event that was not in compliance with basic human rights and the Geneva Conventions. CIVILIAN-14 did, however, notice "a lot of detainee nakedness at Abu Ghraib," possibly, he speculated, attributable to the lack of available clothing. There was nothing he observed or heard that he considered detainee abuse. Relating to his JTF-GTMO experience/training, CIVILIAN-14 believed the removal of clothing for interrogation purposes was an option available with the appropriate approvals; however, it was rarely used at JTF-GTMO. This misunderstanding of the rules and regulations was evident in his reaction to the detainee nakedness at Abu Ghraib. Clearly CIVILIAN-14 was not aware of the fact the SECDEF had withdrawn that authority. (Reference Annex B, Appendix 1, CIVILIAN-14)

(g) (U) In reviewing his activities while at Abu Ghraib, SOLDIER-03 recalled his team submitted two requests to use techniques requiring approvals beyond the team level. In cases requiring such approvals, the request went to the Operations Officer (either MAJ Thompson or MAJ Price) (Operations Officer) and they would approve or disapprove the technique. Those requests requiring a CJTF-7 approval level went to CPT Wood who would forward them for approval. SOLDIER-03 recalled submitting the requests several days in advance of the interrogation to ensure it was approved or disapproved before the interrogation began. His first request (detainee sitting against a wall) was initiated by SOLDIER-21 (analyst) and SOLDIER-30 (interrogator). SOLDIER-03 reviewed the request and forwarded it for approval (SOLDIER-03 could not recall to whom he submitted the request or who had approved it). The request was approved and was implemented. After "observing for a couple of minutes," SOLDIER-03 ended the interrogation. In preparation for another interrogation, the same two females (SOLDIER-21 and SOLDIER-30) submitted a request to interrogate a detainee naked. The request was reviewed by SOLDIER-03 and forwarded to MAJ Price. MAJ Price denies ever approving a naked interrogation. SOLDIER-03 recalled that the technique had been approved, but could not recall by whom. As with the above interrogation, SOLDIER-03 observed the interrogation. After about 15 minutes, he determined the nudity was not a productive technique and terminated the session. SOLDIER-03 never discussed this incident with SOLDIER-28. In his opinion, he had obtained the appropriate authorities and approvals for an "acceptable technique." When asked, SOLDIER-03 recalled hearing about nakedness at GTMO, but never employed the technique. (Reference Annex B, Appendix 1, SOLDIER-03, PRICE).

(h) (U) The JTF-GTMO Team viewed itself as having the mission of setting up and organizing an effective and efficient JIDC staff, and assisting in establishing the Tiger Team

SUBJECT: (U) AR 15-6 Investigation of the Abu Ghraib Detention Facility and
205th MI Brigade

concept based on the GTMO model and experience. They did not view their mission as being for training specific interrogation techniques. This is contrary to MG G. Miller's understanding of the mission. There is no evidence that the JTF-GTMO team intentionally introduced any new/prohibited interrogation techniques. Clearly, however, they were operating without a full understanding of the current JTF-GTMO ICRP.

(i) (U) According to SOLDIER-28, no After Action Report (AAR) was prepared for this mobile training team's effort. He provided a post-mission briefing to MG G. Miller upon his return to GTMO. The team's mission was not clearly defined until they arrived at Abu Ghraib. According to MAJ Price (Reference Annex B, Appendix 1, PRICE), the JTF-GTMO Team arrived without a defined charter; however, in his opinion, the team's suggestions were very good and exactly what the Abu Ghraib operation needed. MAJ Price felt that the real changes began to show after COL Pappas arrived on or about 16 November 2003.

(3) (U) Fort Huachuca Mobile Training Team

(a) (U) From 7 to 21 October 2003, a five person ISCT MTT from the USAIC, Fort Huachuca, AZ, was dispatched to conduct an overall assessment of interrogation operations, present training, and provide advice and assistance at the Abu Ghraib JIDC. This course was developed in response to requirements surfaced during interrogation operations at JTF-GTMO, specifically to prepare reserve interrogators and order of battle analysts for deployment to JTF-GTMO. The course consists of a refresher in interrogation procedures and an introduction to strategic debriefing procedures (Reference Annex L, Appendix 4, ISCT POI; ISCT MTT AAR). The MTT consisted of a team chief, CW3 Norris (351B), three 97E interrogators, MSG Filhanessian, SFC Fierro and SFC Walters, and one analyst (96B) SOLDIER-56. The MTT spent the first few days at Abu Ghraib observing ongoing JIDC interrogation operations and establishing a training schedule based on their observations. The training phase lasted approximately five days and focused on interrogation skills and elicitation techniques, cultural awareness, collection management, and use of interpreters. The team discussed the use of Tiger Teams, but did not conduct any training in their use. The Tiger Team concept of teaming an Interrogator and an Analyst together had been previously recommended by the GTMO Assessment Team and was already being employed at Abu Ghraib when the ISCT MTT arrived. Following the training, at least two ISCT MTT Interrogators participated in approximately 19 interrogations and observed several others. The MTT prepared an After Action Report (Reference Annex L, Appendix 4, ISCT MTT AAT, Joint Detainee Interrogation Center, CJTF-7, Abu Ghurayb (sic), Iraq, dated 3 November 2003), which noted eleven issues and provided recommendations for each. The issues mainly concerned screening procedures, interrogation planning and preparation, approaches, questioning, interpreter control, deception detection, and administrative and reporting issues. SFC Filhanessian did recall they had access to the 16 April 2003 SECDEF Memorandum and devoted some time to discussing approach strategies outside

SUBJECT: (U) AR 15-6 Investigation of the Abu Ghraib Detention Facility and
205th MI Brigade

the ones mentioned in FM 34-52, Intelligence Interrogations, 28 September 1992, like the issue of military working dogs, sleep deprivation, etc., (Reference Annex B, Appendix 1, FILHANESSIAN). According to SOLDIER-25 (Reference Annex B, Appendix 1, SOLDIER25), "A team from Fort Huachuca ... gave us 3 days of classes, including rules of engagement and the use of sleep deprivation and sleep management." The ISCT MTT AAR did not note any incidents of detainee abuse or mistreatment. Three interviewed ISCT MTT members stated that they did not witness, or hear of any incidents of detainee abuse or mistreatment. Neither did they observe or know of any incidents where MI instructed or insinuated that the MP should abuse detainees. Further, MTT members stated that the 519 MI BN interrogators at Abu Ghraib demonstrated experience, "did things by the book," and used techniques that were within the limitations established by FM 34-52 (Interrogation Operations). Some team members, however, expressed some concerns about what appeared to them to be a lack of experience with some of the civilian contracted CACI Interrogators, and the fact that the MTT did not have the opportunity to train and work with some newly arriving contractors (Reference Annex B, Appendix 1, WALTERS; CIVILIAN-07; and FIERRO).

(b) (U) On 21 June 2004, SFC Walters contacted the investigative team via email and indicated he wanted to make additions to his statement (Reference Annex B, Appendix 1, WALTERS 20040621, email). SFC Walters was concerned that as a member of the ISCT MTT, he may have contributed to the abuse at Abu Ghraib. When questioned by CACI employee CIVILIAN-21 for ideas to use to get these prisoners to talk, SFC Walters related several stories about the use of dogs as an inducement, suggesting he (CIVILIAN-21) talk to the MPs about the possibilities. SFC Walters further explained that detainees are most susceptible during the first few hours after capture. "The prisoners are captured by Soldiers, taken from their familiar surroundings, blindfolded and put into a truck and brought to this place (Abu Ghraib); and then they are pushed down a hall with guards barking orders and thrown into a cell, naked; and that not knowing what was going to happen or what the guards might do caused them extreme fear." SFC Walters also suggested CIVILIAN-21 could take some pictures of what seemed to be guards being rough with prisoners...so he could use them to scare the prisoners. Lastly, SFC Walters also shared what he described as a formal, professional prisoner in-processing as he observed it in Bagram (a reference to the detainee operations that had taken place Afghanistan).

(c) (U) On 26 June 2004, during a follow-on interview (Reference Annex B, Appendix 1, WALTERS); SFC Walters confirmed the information he provided in his email. He clarified that his conversation with CIVILIAN-21 occurred before the training was conducted and that he was certain CIVILIAN-21 clearly understood the rules with regard to interrogations. SFC Walters was adamant he had stressed the need to obtain the appropriate authorities before using any of the techniques discussed. SFC Walters knew of no other "off line" conversations between the MTT members and assigned interrogators. SFC Walters said he had related stories he had heard, but did not personally observe. In addressing the ISCT MTT training objectives, SFC

SUBJECT: (U) AR 15-6 Investigation of the Abu Ghraib Detention Facility and
205th MI Brigade

Walters noted they (ISCT MTT) did not agree with the JTF-GTMO modus operandi. The (ISCT MTT) felt the use of Tiger Teams wasted limited analytical support. Analysts should support interrogation teams and not be part of the interrogation. This mirrors the opinions of the Abu Ghraib team (Reference Annex B, Appendix 1, WOOD).

(d) (U) Throughout OIF I, USAIC assisted in sending MTTs to all divisional locations within Iraq in order to provide instruction on THT operations, G2X staff functions, and tactical questioning for non-military intelligence Soldiers. Prior to this training, a separate team traveled to Afghanistan and Iraq to provide similar training at Bagram Airfield and Abu Ghraib Detention Facility. This training was the same training provided to OIF units in Iraq that also incorporated lessons learned during that MTT.

k. (U) International Committee of the Red Cross (ICRC)

(1) (U) The ICRC visits to Abu Ghraib have been the source of great concern since the abuses at Abu Ghraib became public knowledge. The ICRC are independent observers who identified abuses to the leadership of Abu Ghraib as well as to CJTF-7. Their allegations were not believed, nor were they adequately investigated.

(2) (U) During the 9-12 and 21-23 October 2003 visits to Abu Ghraib, the ICRC noted that the ill treatment of detainees during interrogation was not systemic, except with regard to persons arrested in connection with suspected security offenses or deemed to have an "intelligence value." These individuals were probably the MI holds. "In these cases, persons deprived of their liberty [and] under supervision of the Military Intelligence were at high risk of being subjected to a variety of harsh treatments. These ranged from insults, threat and humiliations, to both physical and psychological coercion (which in some cases was tantamount to torture) in order to force cooperation with their interrogators (Reference Annex G, Appendix 1, Executive Summary)." The ICRC noted that some detainees in Tier 1A were held naked in their cells, with meals ready to eat (MRE) packing being used to cover their nudity. The ICRC immediately informed the authorities, and the detainees received clothes for the remainder of the ICRC visit. Additionally, the ICRC complained about MI-imposed restrictions on visiting certain security detainees in Camp Vigilant and in Tier 1A. Red Cross delegates were informed they could visit those areas the following day and then only on the basis of a list of detainees and tasks agreed on with Abu Ghraib officials. (Reference Annex G, Appendix 1, TAB B)

(3) (U) The ICRC found a high level of depression, feelings of helplessness, stress, and frustration, especially by those detainees in isolation. Detainees made the following allegations during interviews with the ICRC: threats during interrogation; insults and verbal insults during transfer in Tier 1A; sleep deprivation; walking in the corridors handcuffed and naked, except for female underwear over the head; handcuffing either to the upper bed bars or doors of the cell for

SUBJECT: (U) AR 15-6 Investigation of the Abu Ghraib Detention Facility and
205th MI Brigade

3-4 hours. Some detainees presented physical marks and psychological symptoms which were compatible with these allegations. Also noted were brutality upon capture, physical or psychological coercion during interrogation, prolonged isolation, and excessive and disproportionate use of force. (Reference Annex G, Appendix 1, TAB B)

(4) (U) The ICRC made a number of recommendations after the October 2003 visits, including: grant ICRC full and unimpeded access to all detainees; improve the security related to the accommodation structure; clarify and improve conditions of detention and treatment; distribute hygiene items, spare clothes, blankets, etc.; inform detainees of the reason for their detention; implement regular family visits for detainees; and increase recreational and educational activities. (Reference Annex G, Appendix 1, Tab B, ICRC Working Paper, dated 6 November 2003).

(5) (U) LTC Phillabaum, regarding the 9 – 12 October 2003 visit, stated he was told of naked detainees by the ICRC and immediately contacted LTC Jordan. The two went to see the situation first hand. LTC Phillabaum claimed that LTC Jordan acknowledged that it was common practice for some of the detainees to be kept naked in their cells. In November 2003, after having received the written ICRC report, CJTF-7 sent an Australian Judge Advocate officer, MAJ George O’Kane, to Abu Ghraib to meet with LTC Jordan and other officers to craft a response to the ICRC memo. (Reference Annex B, Appendices 1 and 2, PHILLABAUM)

(6) (U) Stemming from those October 2003 visits, the ICRC also made the following request of the Coalition Forces: respect at all times the human dignity, physical integrity, and cultural sensitivity of detainees; set up a system of notification of arrest to the families of detainees; prevent all forms of ill-treatment; respect and protect the dignity of detainees; allow sufficient time for outside activity and exercise; define and apply regulations compatible with international Humanitarian Law; thoroughly investigate violation of international Humanitarian Law; ensure that capturing forces and interment facility personnel are trained to function in a proper manner without resorting to ill-treatment of detainees. (Reference ANNEX G, Appendix 1, Tab A, ICRC Report February 2004)

(7) (U) COL Warren, the CJTF-7 SJA, stated that neither he nor anyone else from CJTF-7 Headquarters was present at Abu Ghraib during the ICRC visit in October 2003. Throughout 2003, all ICRC reports were addressed to the commander or subordinate commanders of the 800 MP BDE. The OSJA received a copy of the reports. Letters on specific topics addressed to LTG Sanchez were given to COL Warren and he would prepare the response for LTG Sanchez. MAJ O’Kane prepared an analysis of the report on 25 November 2003 and the draft was sent to CJTF-7 C2 and the 800 MP BDE for review. On 4 December 2003, a meeting was held at Abu Ghraib, attended by MP, MI, and legal personnel, in order to discuss the report. In mid-December, the draft response was sent by OSJA to the 800 MP BDE for review and coordination. BG

SUBJECT: (U) AR 15-6 Investigation of the Abu Ghraib Detention Facility and
205th MI Brigade

Karpinski signed the response, dated 24 December 2003. (Reference Annex G, Appendix 3, KARPINSKI Letter)

(8) (U) During the 4-8 January 2004 visit, the ICRC expressed special concern over being informed by COL Pappas and COL Warren that they were invoking Article 143 of Geneva Convention IV, thereby denying the ICRC access to eight of the detainees in the interrogation section. Of particular interest was the status of detainee DETAINEE-14, a Syrian national and self-proclaimed Jihadist, who was in Iraq to kill coalition troops. DETAINEE-14 was detained in a totally darkened cell measuring about 2 meters long and less than a meter across, devoid of any window, latrine or water tap, or bedding. On the door the ICRC delegates noticed the inscription "the Gollum," and a picture of the said character from the film trilogy "Lord of the Rings." During the 14-18 March 2004 visit, the ICRC was once again denied access to nine detainees, including DETAINEE-14. They noted that DETAINEE-14 was no longer in the same cell as he was previously, but was still in one of the more "difficult" cells. (Reference Annex G, Appendix 1, ICRC Working Paper, dated 6 November 2003; Appendix 2, ICRC Letter dated February 2004; Appendix 2, Tab B, ICRC Letter dated 25 March 2004)

(9) (U) Article 143, Fourth Geneva Convention, reads in part "Such visits may be prohibited except for reasons of imperative military necessity, and then only for an exceptional and temporary measure." COL Warren and COL Pappas both acknowledge denying access to specified detainees by the ICRC on each of two occasions (in January and March 2004), invoking the above cited provision. The ICRC, in their memorandum of 25 March 2004, acknowledged the right of COL Warren and COL Pappas to invoke the "imperative military necessity clause." It questioned the "exceptional and temporary" nature of the denial of access to DETAINEE-14 on both occasions, however, given that DETAINEE-14 (by the time of the second visit) had been under interrogation for some four months. This was the same DETAINEE-14 that was viewed a "special project" and who was abused by the use of dogs. (See paragraph 5.f.) (Reference Annex B, Appendix 1, PAPPAS, WARREN)

(10) (U) COL Pappas acknowledges in his statement that the ICRC visited Abu Ghraib twice (January and March 2004). He received a copy of the results and noted there were allegations of maltreatment and detainees wearing women's underwear on their heads. He did not believe it. He recalled he might have related to the staff that "this stuff couldn't have been happening." He added that when the ICRC came by the second time (March 2004), he invoked Article 143, preventing the eight detainees in Tier 1A from talking to the ICRC while undergoing active interrogation. COL Pappas states: "COL Warren informed me that I had the authority to do this." (Reference Annex B, Appendices 1 and 2, PAPPAS)

(11) (U) COL Warren also stated that when he saw the ICRC report on naked detainees and detainees wearing women's underwear, he couldn't believe it. He saw the report when he

SUBJECT: (U) AR 15-6 Investigation of the Abu Ghraib Detention Facility and
205th MI Brigade

returned to CJTF-7 from leave on 30 November 2003. His office probably had received the report on 16 November 2003. He regrets not having taken the report earlier to LTG Sanchez or MG Wojdakowski. While this would not have prevented the abuse they subsequently discovered (because it had taken place in November 2003), it may have resulted in CID beginning an investigation a month earlier than they did. During the ICRC's next visit to Abu Ghraib, during the period 4-8 January 2004, COL Warren states they invoked Article 143 of the Fourth Geneva Conventions and did not allow the ICRC to have private interviews with eight detainees who were undergoing active interrogations. He did allow the ICRC delegate to see the detainees, observe the conditions of their detention, and obtain their names and Internee Serial Numbers." (Reference Annex B, Appendix 1, WARREN)

(12) (U) LTC Chew, Commander of the 115th MP Battalion (115 MP BN), has stated that although he attended the ICRC out-brief, after the 21-23 October 2003 visits, he never saw or heard of any detainees being stripped or held naked, nor did he ever see a written report from the ICRC. He stated that a doctor with the ICRC team provided information concerning a few detainees having psychological problems and stating that they should be evaluated. ICRC also related charges of handcuffing, nakedness, wearing of female underwear, and sleep deprivation. The ICRC also complained about lack of access to certain detainees, and he discussed the matter with LTC Jordan. He also discussed the allegations made by the ICRC with MAJ Potter, BG Karpinski, and MAJ Cavallero. BG Karpinski does not recall hearing about the report until early December 2003 when it was discussed at CJTF-7 Headquarters with COL Warren. (Reference Annex B, Appendix 1, CHEW, KARPINSKI)

(13) (U) LTC Jordan has stated that after the ICRC visited Abu Ghraib, COL Pappas and BG Karpinski received the final report, but that he did not see the report. When asked by COL Pappas if he had ever seen or heard any rumors of abuse, LTC Jordan told COL Pappas that he (LTC Jordan) had not. He was not aware of COL Pappas ever doing anything concerning the ICRC allegations (Reference Annex B, Appendix 1, JORDAN and Annex B, Appendix 2, JORDAN).

(14) (U) The only response to the ICRC was a letter signed by BG Karpinski, dated 24 December 2003. According to LTC Phillabaum and COL Warren (as quoted above) an Australian Judge Advocate officer, MAJ O'Kane, was the principal drafter of the letter. Attempts to interview MAJ O'Kane were unsuccessful. The Australian Government agreed to have MAJ O'Kane respond to written questions, but as of the time of this report, no response has been received. The section of the BG Karpinski letter pertaining to Abu Ghraib primarily addresses the denial of access to certain detainees by the ICRC. It tends to gloss over, close to the point of denying the inhumane treatment, humiliation, and abuse identified by the ICRC. The letter merely says: Improvement can be made for the provision of clothing, water, and personal hygiene items. (Reference Annex G, Appendix 3, KARPINSKI Letter)

SUBJECT: (U) AR 15-6 Investigation of the Abu Ghraib Detention Facility and
205th MI Brigade

5. Summary of Abuses at Abu Ghraib

a. (U) Several types of detainee abuse were identified in this investigation: physical and sexual abuse; improper use of military working dogs; humiliating and degrading treatments; and improper use of isolation.

(1) (U) Physical Abuse. Several Soldiers reported that they witnessed physical abuse of detainees. Some examples include slapping, kicking, twisting the hands of a detainee who was hand-cuffed to cause pain, throwing balls at restrained internees, placing gloved hand over the nose and mouth of an internee to restrict breathing, "poking" at an internee's injured leg, and forcing an internee to stand while handcuffed in such a way as to dislocate his shoulder. These actions are clearly in violation of applicable laws and regulations.

(2) (U) Use of Dogs. The use of military working dogs in a confinement facility can be effective and permissible under AR 190-12 as a means of controlling the internee population. When dogs are used to threaten and terrify detainees, there is a clear violation of applicable laws and regulations. One such impermissible practice was an alleged contest between the two Army dog handlers to see who could make the internees urinate or defecate in the presence of the dogs. An incident of clearly abusive use of the dogs occurred when a dog was allowed in the cell of two male juveniles and allowed to go "nuts." Both juveniles were screaming and crying with the youngest and smallest trying to hide behind the other juvenile. (Reference Annex B, Appendix 1, SOLDIER-17)

(3) (U) Humiliating and Degrading Treatments. Actions that are intended to degrade or humiliate a detainee are prohibited by GC IV, Army policy and the UCMJ. The following are examples of such behavior that occurred at Abu Ghraib, which violate applicable laws and regulations.

(4) (U) Nakedness. Numerous statements, as well as the ICRC report, discuss the seemingly common practice of keeping detainees in a state of undress. A number of statements indicate that clothing was taken away as a punishment for either not cooperating with interrogators or with MPs. In addition, male internees were naked in the presence of female Soldiers. Many of the Soldiers who witnessed the nakedness were told that this was an accepted practice. Under the circumstances, however, the nakedness was clearly degrading and humiliating.

(5) (U) Photographs. A multitude of photographs show detainees in various states of undress, often in degrading positions.

SUBJECT: (U) AR 15-6 Investigation of the Abu Ghraib Detention Facility and
205th MI Brigade

(6) (U) Simulated Sexual Positions. A number of Soldiers describe incidents where detainees were placed in simulated sexual positions with other internees. Many of these incidents were also photographed.

(7) (U) Improper Use of Isolation. There are some legitimate purposes for the segregation (or isolation) of detainees, specifically to prevent them from sharing interrogation tactics with other detainees or other sensitive information. Article 5 of Geneva Convention IV supports this position by stating that certain individuals can lose their rights of communication, but only when absolute military security requires. The use of isolation at Abu Ghraib was often done as punishment, either for a disciplinary infraction or for failure to cooperate with an interrogation. These are improper uses of isolation and depending on the circumstances amounted to violation of applicable laws and regulations. Isolation could properly be a sanction for a disciplinary infraction if applied through the proper process set out in AR 190-8 and the Geneva Conventions.

(8) (U) Failure to Safeguard Detainees. The Geneva Conventions and Army Regulations require that detainees be “protected against all acts of violence and threats thereof and against insults and public curiosity.” Geneva Convention IV, Article 27 and AR 190-8, paragraph 5-1(a)(2). The duty to protect imposes an obligation on an individual who witnesses an abusive act to intervene and stop the abuse. Failure to do so may be a violation of applicable laws and regulations.

(9) (U) Failure to Report Detainee Abuse. The duty to report detainee abuse is closely tied to the duty to protect. The failure to report an abusive incident could result in additional abuse. Soldiers who witness these offenses have an obligation to report the violations under the provision of Article 92, UCMJ. Soldiers who are informed of such abuses also have a duty to report violations. Depending on their position and their assigned duties, the failure to report detainee abuse could support a charge of dereliction of duty, a violation of the UCMJ. Civilian contractors employed as interrogators and translators would also have a duty to report such offenses as they are also bound by the Geneva Conventions and are charged with protecting the internees.

(10) (U) Other traditional prison guard issues were far less clear. MPs are responsible for the clothing of detainees; however, MI interrogators started directing nakedness at Abu Ghraib as early as 16 September 2003 to humiliate and break down detainees. MPs would also sometimes discipline detainees by taking away clothing and putting detainees in cells naked. A severe shortage of clothing during the September, October, November 2003, time frame was frequently mentioned as the reason why people were naked. Removal of clothing and nakedness were being used to humiliate detainees at the same time there was a general level of confusion as to what was allowable in terms of MP disciplinary measures and MI interrogation rules, and what

SUBJECT: (U) AR 15-6 Investigation of the Abu Ghraib Detention Facility and
205th MI Brigade

clothing was available. This contributed to an environment that would appear to condone depravity and degradation rather than the humane treatment of detainees.

b. (U) The original intent by MI leadership (205 MI BDE) was for Tier 1A to be reserved for MI Holds only. In fact, CPT Wood states in an email dated 7 September 2003, during a visit from MG Miller and BG Karpinski, that BG Karpinski confirmed “we (MI) have all the iso (Isolation) cells in the wing we have been working. We only had 10 cells to begin with but that has grown to the entire wing.” LTC Phillabaum also thought that MI had exclusive authority to house MI holds in Tier 1A. The fact is, however, that a number of those cells were often used by the MPs to house disciplinary problems. That fact is supported by the testimony of a large number of people who were there and further supported by the pictures and the detainee records. In fact, 11 of a total of 25 detainees identified by the CID as victims of abuse were not MI holds and were not being interrogated by MI. The MPs put the problem detainees (detainees who required separation from the general population for disciplinary reasons) in Tier 1A because there was no other place available to isolate them. Neither CPT Wood nor MAJ Williams appreciated the mixing because it did not allow for a pure MI environment, but the issue never made its way up to either LTC Phillabaum or to BG Karpinski.

c. (U) The “sleep adjustment” technique was used by MI as soon as the Tier 1A block opened. This was another source of confusion and misunderstanding between MPs and MI which contributed to an environment that allowed detainee abuse, as well as its perpetuation for as long as it continued. Sleep adjustment was brought with the 519 MI BN from Afghanistan. It is also a method used at GTMO. (See paragraph 3.b.(5)). At Abu Ghraib, however, the MPs were not trained, nor informed as to how they actually should do the sleep adjustment. The MPs were just told to keep a detainee awake for a time specified by the interrogator. The MPs used their own judgment as to how to keep them awake. Those techniques included taking the detainees out of their cells, stripping them and giving them cold showers. CPT Wood stated she did not know this was going on and thought the detainees were being kept awake by the MPs banging on the cell doors, yelling, and playing loud music. When one MI Soldier inquired about water being thrown on a naked detainee he was told that it was an MP discipline technique. Again, who was allowed to do what and how exactly they were to do it was totally unclear. Neither of the communities (MI and MP) knew what the other could and could not do. (Reference Annex B, Appendix 1, WOOD, JOYNER)

d. (U) This investigation found no evidence of confusion regarding actual physical abuse, such as hitting, kicking, slapping, punching, and foot stomping. Everyone we spoke to knew it was prohibited conduct except for one Soldier. (Reference Annex B, Appendix 1, SOLDIER-29). Physical discomfort from exposure to cold and heat or denial of food and water is not as clear-cut and can become physical or moral coercion at the extreme. Such abuse did occur at Abu Ghraib, such as detainees being left naked in their cells during severe cold weather without

SUBJECT: (U) AR 15-6 Investigation of the Abu Ghraib Detention Facility and
205th MI Brigade

blankets. In Tier 1A some of the excesses regarding physical discomfort were being done as directed by MI and some were being done by MPs for reasons not related to interrogation. (See paragraph 5.e.-h.)

e. (U) The physical and sexual abuses of detainees at Abu Ghraib are by far the most serious. The abuses spanned from direct physical assault, such as delivering head blows rendering detainees unconscious, to sexual posing and forced participation in group masturbation. At the extremes were the death of a detainee in OGA custody, an alleged rape committed by a US translator and observed by a female Soldier, and the alleged sexual assault of an unknown female. They were perpetrated or witnessed by individuals or small groups. Such abuse can not be directly tied to a systemic US approach to torture or approved treatment of detainees. The MPs being investigated claim their actions came at the direction of MI. Although self-serving, these claims do have some basis in fact. The climate created at Abu Ghraib provided the opportunity for such abuse to occur and to continue undiscovered by higher authority for a long period of time. What started as undressing and humiliation, stress and physical training (PT), carried over into sexual and physical assaults by a small group of morally corrupt and unsupervised Soldiers and civilians. Twenty-four (24) serious incidents of physical and sexual abuse occurred from 20 September through 13 December 2003. The incidents identified in this investigation include some of the same abuses identified in the MG Taguba investigation; however, this investigation adds several previously unreported events. A direct comparison cannot be made of the abuses cited in the MG Taguba report and this one.

(1) (U) **Incident #1.** On 20 September 2003, two MI Soldiers beat and kicked a passive, cuffed detainee, suspected of involvement in the 20 September 2003 mortar attack on Abu Ghraib that killed two Soldiers. Two Iraqis (male and female) were detained and brought to Abu Ghraib immediately following the attack. MI and the MP Internal Reaction Force (IRF) were notified of the apprehension and dispatched teams to the entry control point to receive the detainees. Upon arrival, the IRF observed two MI Soldiers striking and yelling at the male detainee whom they subsequently “threw” into the back of a High-Mobility Multipurpose Wheeled Vehicle (HMMWV). 1LT Sutton, 320th MP BN IRF intervened to stop the abuse and was told by the MI Soldiers “we are the professionals; we know what we are doing.” They refused 1LT Sutton’s lawful order to identify themselves. 1LT Sutton and his IRF team (SGT Spiker, SFC Plude) immediately reported this incident, providing sworn statements to MAJ Dinenna, 320 MP BN S3 and LTC Phillabaum, 320 MP BN Commander. 1SG McBride, A/205 MI BN interviewed and took statements from SGT Lawson, identified as striking the detainee, and each MI person present: SSG Hannifan, SSG Cole, SGT Claus, SGT Presnell. While the MP statements all describe abuse at the hands of an unidentified MI person (SGT Lawson), the MI statements all deny any abuse occurred. LTC Phillabaum subsequently reported the incident to the CID who determined the allegation lacked sufficient basis for prosecution. The detainee was interrogated and released that day (involvement in the mortar attack was unlikely); therefore, no

SUBJECT: (U) AR 15-6 Investigation of the Abu Ghraib Detention Facility and
205th MI Brigade

detainee is available to confirm either the MP or MI recollection of events. This incident was not further pursued based on limited data and the absence of additional investigative leads.

(Reference Annex B, Appendix 1, DINENNA, LAWSON, MCBRIDE, PHILLABAUM, PLUDE, SPIKER, SUTTON; Annex B, Appendix 2, DINENNA, PHILLABAUM, PLUDE; Annex B, Appendix 3, PLUDE, SPIKER)

(2) (U) **Incident #2.** On 7 October 2003, three MI personnel allegedly sexually assaulted female DETAINEE-29. CIVILIAN-06 (Titan) was the assigned interpreter, but there is no indication he was present or involved. DETAINEE-29 alleges as follows: First, the group took her out of her cell and escorted her down the cellblock to an empty cell. One unidentified Soldier stayed outside the cell (SOLDIER33, A/519 MI BN); while another held her hands behind her back, and the other forcibly kissed her (SOLDIER32, A/519 MI BN). She was escorted downstairs to another cell where she was shown a naked male detainee and told the same would happen to her if she did not cooperate. She was then taken back to her cell, forced to kneel and raise her arms while one of the Soldiers (SOLDIER31, A/519 MI BN) removed her shirt. She began to cry, and her shirt was given back as the Soldier cursed at her and said they would be back each night. CID conducted an investigation and SOLDIER33, SOLDIER32, and SOLDIER31 invoked their rights and refused to provide any statements. DETAINEE-29 identified the three Soldiers as SOLDIER33, SOLDIER32, and SOLDIER31 as the Soldiers who kissed her and removed her shirt. Checks with the 519 MI BN confirmed no interrogations were scheduled for that evening. No record exists of MI ever conducting an authorized interrogation of her. The CID investigation was closed. SOLDIER33, SOLDIER32, and SOLDIER31 each received non-judicial punishment, Field Grade Article 15's, from the Commander, 205 MI BDE, for failing to get authorization to interrogate DETAINEE-29. Additionally, COL Pappas removed them from interrogation operations. (Reference Annex B, Appendix 1, PAPPAS; Annex B, Appendix 2, PAPPAS; Annex B, Appendix 3, DETAINEE-29).

(3) **Incident #3.** On 25 October 2003 detainees DETAINEE-31, DETAINEE-30, and DETAINEE-27 were stripped of their clothing, handcuffed together nude, placed on the ground, and forced to lie on each other and simulate sex while photographs were taken. Six photographs depict this abuse. Results of the CID investigation indicate on several occasions over several days, detainees were assaulted, abused and forced to strip off their clothing and perform indecent acts on each other. DETAINEE-27 provided a sworn statement outlining these abuses. Those present and/or participating in the abuse were CPL Graner, 372 MP CO, SSG Frederick, 372 MP CO, SPC England, 372 MP CO, SPC Harman, 372 MP CO, SOLDIER34, 372 MP CO, CIVILIAN-17, Titan Corp., SOLDIER-24, B/325 MI BN, SOLDIER19, 325 MI BN, and SOLDIER10, 325 MI BN. SOLDIER-24 claimed he accompanied SOLDIER10 to the Hard Site the evening of 25 October 2003 to see what was being done to the three detainees suspected of raping a young male detainee. SOLDIER-10 appeared to have foreknowledge of the abuse, possibly from his friendship with SPC Harman, a 372 MP CO MP. SOLDIER-24 did not believe

SUBJECT: (U) AR 15-6 Investigation of the Abu Ghraib Detention Facility and
205th MI Brigade

the abuse was directed by MI and these individuals were not interrogation subjects. PFC England, however, claimed "MI Soldiers instructed them (MPs) to rough them up." When SOLDIER-24 arrived the detainees were naked, being yelled at by an MP through a megaphone. The detainees were forced to crawl on their stomachs and were handcuffed together. SOLDIER-24 observed SOLDIER-10 join in the abuse with CPL Graner and SSG Frederick. All three made the detainees act as though they were having sex. He observed SOLDIER-19 dump water on the detainees from a cup and throw a foam football at them. SOLDIER-24 described what he saw to SOLDIER-25, B/321 MI BN, who reported the incident to SGT Joyner, 372 MP CO. SGT Joyner advised SOLDIER-25 he would notify his NCOIC and later told SOLDIER-25 "he had taken care of it." SOLDIER-25 stated that a few days later both she and SOLDIER-24 told SOLDIER-22 of the incident. SOLDIER-22 subsequently failed to report what he was told. SOLDIER-25 did not report the abuse through MI channels because she felt it was an MP matter and would be handled by them.

(U) This is a clear incident of direct MI personnel involvement in detainee abuse; however, it does not appear to be based on MI orders. The three detainees were incarcerated for criminal acts and were not of intelligence interest. This incident was most likely orchestrated by MP personnel (CPL Graner, SSG Frederick, SOLDIER-34, SPC Harman, PFC England), with the MI personnel (SOLDIER-19, SOLDIER-10, and SOLDIER-24, CIVILIAN-17, and another unidentified interpreter) joining in and/or observing the abuse. (Reference Annex B, Appendix 1, JOYNER, SOLDIER-19, CIVILIAN-17, SOLDIER-25; Annex B, Appendix 3, SOLDIER-34, ENGLAND, HARMAN, DETAINEE-31, DETAINEE-30, DETAINEE-27; Annex I, Appendix 1, Photographs M36-41).

(4) (U) **Incident #4.** DETAINEE-08, arrived at Abu Ghraib on 27 October 2003 and was subsequently sent to the Hard Site. DETAINEE-08 claims when he was sent to the Hard Site, he was stripped of his clothing for six days. He was then given a blanket and remained with only the blanket for three more days. DETAINEE-08 stated the next evening he was transported by CPL Graner, 372 MP CO MP, to the shower room, which was commonly used for interrogations. When the interrogation ended, his female interrogator left, and DETAINEE-08 claims CPL Graner and another MP, who meets the description of SSG Fredrick, then threw pepper in DETAINEE-08's face and beat him for half an hour. DETAINEE-08 recalled being beaten with a chair until it broke, hit in the chest, kicked, and choked until he lost consciousness. On other occasions DETAINEE-08 recalled that CPL Graner would throw his food into the toilet and say "go take it and eat it." DETAINEE-08's claims of abuse do not involve his interrogator(s) and appear to have been committed by CPL Graner and SSG Frederick, both MPs. Reviewing the interrogation reports; however, suggests a correlation between this abuse and his interrogations. DETAINEE-08's interrogator for his first four interrogations was SOLDIER-29, a female, and almost certainly the interrogator he spoke of. Her Analyst was SOLDIER-10. In the first interrogation report they concluded he was lying and recommended a "fear up" approach if he continued to lie. Following his second interrogation it was recommended DETAINEE-08 be

SUBJECT: (U) AR 15-6 Investigation of the Abu Ghraib Detention Facility and
205th MI Brigade

moved to isolation (the Hard Site) as he continued “to be untruthful.” Ten days later, a period roughly correlating with DETAINEE-08’s claim of being without clothes and/or a blanket for nine days before his beating, was interrogated for a third time. The interrogation report references his placement in “the hole,” a small lightless isolation closet, and the “Mutt and Jeff” interrogation technique being employed. Both techniques as they were used here were abusive and unauthorized. According to the report, the interrogators “let the MPs yell at him” and upon their return, “used a fear down,” but “he was still holding back.” The following day he was interrogated again and the report annotates “use a direct approach with a reminder of the unpleasantness that occurred the last time he lied.” Comparing the interrogation reports with DETAINEE-08’s recollections, it is likely the abuse he describes occurred between his third and fourth interrogations and that his interrogators were aware of the abuse, the “unpleasantness.” SGT Adams stated that SOLDIER-29 and SSG Frederick had a close personal relationship and it is plausible she had CPL Graner and SSG Frederick “soften up this detainee” as they have claimed “MI” told them to do on several, unspecified, occasions (Reference Annex B, Appendix 1, ADAMS, SOLDIER-29; Annex B, Appendix 3, DETAINEE-08; Annex I, Appendix 4, DETAINEE-08).

(5) (U) **Incident #5.** In October 2003, DETAINEE-07, reported alleged multiple incidents of physical abuse while in Abu Ghraib. DETAINEE-07 was an MI Hold and considered of potentially high value. He was interrogated on 8, 21, and 29 October; 4 and 23 November and 5 December 2003. DETAINEE-07’s claims of physical abuse (hitting) started on his first day of arrival. He was left naked in his cell for extended periods, cuffed in his cell in stressful positions (“High cuffed”), left with a bag over his head for extended periods, and denied bedding or blankets. DETAINEE-07 described being made to “bark like a dog, being forced to crawl on his stomach while MPs spit and urinated on him, and being struck causing unconsciousness.” On another occasion DETAINEE-07 was tied to a window in his cell and forced to wear women’s underwear on his head. On yet another occasion, DETAINEE-07 was forced to lie down while MPs jumped onto his back and legs. He was beaten with a broom and a chemical light was broken and poured over his body. DETAINEE-04 witnessed the abuse with the chem-light. During this abuse a police stick was used to sodomize DETAINEE-07 and two female MPs were hitting him, throwing a ball at his penis, and taking photographs. This investigation surfaced no photographic evidence of the chemical light abuse or sodomy. DETAINEE-07 also alleged that CIVILIAN-17, MP Interpreter, Titan Corp., hit DETAINEE-07 once, cutting his ear to an extent that required stitches. He told SOLDIER-25, analyst, B/321 MI BN, about this hitting incident during an interrogation. SOLDIER-25 asked the MPs what had happened to the detainee’s ear and was told he had fallen in his cell. SOLDIER-25 did not report the detainee’s abuse. SOLDIER-25 claimed the detainee’s allegation was made in the presence of CIVILIAN-21, Analyst/Interrogator, CACI, which CIVILIAN-21 denied hearing this report. Two photos taken at 2200 hours, 1 November 2003 depict a detainee with stitches in his ear; however, we could not confirm the photo was DETAINEE-07. Based on the details provided by the detainee and the

SUBJECT: (U) AR 15-6 Investigation of the Abu Ghraib Detention Facility and
205th MI Brigade

close correlation to other known MP abuses, it is highly probable DETAINEE-07's allegations are true. SOLDIER-25 failed to report the detainee's allegation of abuse. His statements and available photographs do not point to direct MI involvement. However, MI interest in this detainee, his placement in Tier 1A of the Hard Site, and initiation of the abuse once he arrived there, combine to create a circumstantial connection to MI (knowledge of or implicit tasking of the MPs to "set conditions") which are difficult to ignore. MI should have been aware of what was being done to this detainee based on the frequency of interrogations and high interest in his intelligence value. (Reference Annex B, Appendix 1, SOLDIER-25, CIVILIAN-21; Annex B, Appendix 3, DETAINEE-04, DETAINEE-07; Annex I, Appendix 1, Photographs M54-55).

(6) (U) **Incident #6.** DETAINEE-10 and DETAINEE-12 claimed that they and "four Iraqi Generals, were abused upon their arrival at the Hard Site. DETAINEE-10 was documented in MP records as receiving a 1.5 inch laceration on his chin, the result of his resisting an MP transfer. His injuries are likely those captured in several photographs of an unidentified detainee with a lacerated chin and bloody clothing which were taken on 14 November, a date coinciding with his transfer. DETAINEE-12 claimed he was slammed to the ground, punched, and forced to crawl naked to his cell with a sandbag over his head. These two detainees as well as the other four (DETAINEE-20, DETAINEE-19, DETAINEE-22, DETAINEE-21) were all high value Iraqi General Officers or senior members of the Iraqi Intelligence Service. MP logs from the Hard Site indicate they attempted to incite a riot in Camp Vigilant while being transferred to the Hard Site. There is no documentation of what occurred at Camp Vigilant or of detainees receiving injuries. When DETAINEE-10 was in-processed into the Hard Site, he was resisting and was pushed against the wall. At that point the MPs noticed blood coming from under his hood and they discovered the laceration on his chin. A medical corpsman was immediately called to suture the detainee's chin. These events are all documented, indicating the injury occurred before the detainee's arrival at the Hard Site and that he received prompt medical attention. When, where, and by whom this detainee suffered his injuries could not be determined nor could an evaluation be made of whether it constituted "reasonable force" in conjunction with a riot. Our interest in this incident stems from MP logs concerning DETAINEE-10 indicating MI provided direction about his treatment. CPL Graner wrote an entry indicating he was told by SFC Joyner, who was in turn told by LTC Jordan, to "Strip them out and PT them." Whether "strip out" meant to remove clothing or to isolate we couldn't determine. Whether "PT them" meant physical stress or abuse can't be determined. The vagueness of this order could, however, have led to any subsequent abuse. The alleged abuse, injury, and harsh treatment correlating with the detainees' transfer to MI hold also suggest MI could have provided direction or MP could have been given the perception they should abuse or "soften up detainees," however, there is no clear proof. (Reference Annex B, Appendix 1, JORDAN, JOYNER; Annex C).

(7) (U) **Incident #7.** On 4 November 2003, a CIA detainee, DETAINEE-28 died in custody in Tier 1B. Allegedly, a Navy SEAL Team had captured him during a joint TF-121/CIA

SUBJECT: (U) AR 15-6 Investigation of the Abu Ghraib Detention Facility and
205th MI Brigade

mission. DETAINEE-28 was suspected of having been involved in an attack against the ICRC and had numerous weapons with him at the time of his apprehension. He was reportedly resisting arrest, and a SEAL Team member butt-stroked him on the side of the head to suppress the threat he posed. CIA representatives brought DETAINEE-28 into Abu Ghraib sometime around 0430 to 0530 without notifying JIDC Operations, in accordance with a supposed verbal agreement with the CIA. While all the details of DETAINEE-28's death are still not known (CIA, DOJ, and CID have yet to complete and release the results of their investigations), SPC Stevanus, an MP on duty at the Hard Site at the time DETAINEE-28 was brought in, stated that two CIA representatives came in with DETAINEE-28 and he was placed in a shower room (in Tier 1B). About 30 to 45 minutes later, SPC Stevanus was summoned to the shower stall, and when he arrived, DETAINEE-28 appeared to be dead. SPC Stevanus removed the sandbag which was over DETAINEE-28's head and checked for the detainee's pulse. He found none. He un-cuffed DETAINEE-28 called for medical assistance, and notified his chain of command. LTC Jordan stated that he was informed of the death shortly thereafter, at approximately 0715 hours. LTC Jordan arrived at the Hard Site and talked to CIVILIAN03, an Iraqi prison medical doctor, who informed him DETAINEE-28 was dead. LTC Jordan stated that DETAINEE-28 was in the Tier 1B shower stall, face down, handcuffed with his hands behind his back. LTC Jordan's version of the handcuffs conflicts with SPC Stevanus' account that he un-cuffed DETAINEE-28. This incident remains under CID and CIA investigation.

(U) A CIA representative identified only as "OTHER AGENCY EMPLOYEE-01" was present, along with several MPs and US medical staff. LTC Jordan recalled that it was "OTHER AGENCY EMPLOYEE-01" who un-cuffed DETAINEE-28 and the body was turned over. LTC Jordan stated that he did not see any blood anywhere, except for a small spot where DETAINEE-28's head was touching the floor. LTC Jordan notified COL Pappas (205 MI BDE Commander), and "OTHER AGENCY EMPLOYEE-01" said he would notify "OTHER AGENCY EMPLOYEE-02," his CIA supervisor. Once "OTHER AGENCY EMPLOYEE-02" arrived, he stated he would call Washington, and also requested that DETAINEE-28's body be held in the Hard Site until the following day. The body was placed in a body bag, packed in ice, and stored in the shower area. CID was notified and the body was removed from Abu Ghraib the next day on a litter to make it appear as if DETAINEE-28 was only ill, thereby not drawing the attention of the Iraqi guards and detainees. The body was transported to the morgue at BIAP for an autopsy, which concluded that DETAINEE-28 died of a blood clot in the head, a likely result of injuries he sustained while resisting apprehension. There is no indication or accusations that MI personnel were involved in this incident except for the removal of the body. (Reference Annex B, Appendix 1, JORDAN, PAPPAS, PHILLABAUM, SNIDER, STEVANUS, THOMPSON; Annex I, Appendix 1, Photographs C5-21, D5-11, M65-69).

(8) (U) **Incident #8.** On 20 October 2003, DETAINEE-03, was allegedly stripped and physically abused for sharpening a toothbrush to make a shank (knife-like weapon).

SUBJECT: (U) AR 15-6 Investigation of the Abu Ghraib Detention Facility and
205th MI Brigade

DETAINEE-03 claimed the toothbrush was not his. An MP log book entry by SSG Frederick, 372 MPs, directed DETAINEE-03 to be stripped in his cell for six days. DETAINEE-03 claimed he was told his clothing and mattress would be taken away as punishment. The next day he claims he was cuffed to his cell door for several hours. He claims he was taken to a closed room where he had cold water poured on him and his face was forced into someone's urine. DETAINEE-03 claimed he was then beaten with a broom and spat upon, and a female Soldier stood on his legs and pressed a broom against his anus. He described getting his clothes during the day from SGT Joyner and having them taken away each night by CPL Graner for the next three days. DETAINEE-03 was an MI Hold but was not interrogated between 16 September and 2 November 2003. It is plausible his interrogators would be unaware of the alleged abuse and DETAINEE-03 made no claim he informed them (Reference Annex B, Appendix 3, DETAINEE-03).

(9) (U) **Incident #9.** Three photographs taken on 25 October 2003 depicted PFC England, 372 MP CO, holding a leash which was wrapped around an unidentified detainee's neck. Present in the photograph is SPC Ambuhl who was standing to the side watching. PFC England claimed in her initial statement to CID that CPL Graner had placed the tie-down strap around the detainee's neck and then asked her to pose for the photograph. There is no indication of MI involvement or knowledge of this incident (Reference Annex E, CID Report and Reference Annex I, Appendix 1, Photographs M33-35).

(10) (U) **Incident #10.** Six Photographs of DETAINEE-15, depict him standing on a box with simulated electrical wires attached to his fingers and a hood over his head. These photographs were taken between 2145 and 2315 on 4 November 2003. DETAINEE-15 described a female making him stand on the box, telling him if he fell off he would be electrocuted, and a "tall black man" as putting the wires on his fingers and penis. From the CID investigation into abuse at Abu Ghraib it was determined SGT J. Davis, SPC Harman, CPL Graner, and SSG Frederick, 372 MP CO, were present during this abuse. DETAINEE-15 was not an MI Hold and it is unlikely MI had knowledge of this abuse (Reference Annex B, Appendix 3, DETAINEE-15; Annex I, Appendix 1, Photographs C1-2, D19-21, M64).

(11) (U) **Incident #11.** Twenty-nine photos taken between 2315 and 0024, on 7 and 8 November 2003 depict seven detainees (DETAINEE-17, DETAINEE-16, DETAINEE-24, DETAINEE-23, DETAINEE-26, DETAINEE-01, DETAINEE-18) who were physically abused, placed in a pile and forced to masturbate. Present in some of these photographs are CPL Graner and SPC Harman. The CID investigation into these abuses identified SSG Frederick, CPL Graner, SGT J. Davis, SPC Ambuhl, SPC Harman, SPC Sivits, and PFC England; all MPs, as involved in the abuses which occurred. There is no evidence to support MI personnel involvement in this incident. CID statements from PFC England, SGT J. Davis, SPC Sivits, SPC Wisdom, SPC Harman, DETAINEE-17, DETAINEE-01, and DETAINEE-16 detail that the

SUBJECT: (U) AR 15-6 Investigation of the Abu Ghraib Detention Facility and
205th MI Brigade

detainees were stripped, pushed into a pile, and jumped on by SGT J. Davis, CPL Graner, and SSG Frederick. They were photographed at different times by SPC Harman, SPC Sivits, and SSG Frederick. The detainees were subsequently posed sexually, forced to masturbate, and “ridden like animals.” CPL Graner knocked at least one detainee unconscious and SSG Frederick punched one so hard in the chest that he couldn’t breath and a medic was summoned. SSG Frederick initiated the masturbation and forced the detainees to hit each other. PFC England stated she observed SSG Frederick strike a detainee in the chest during these abuses. The detainee had difficulty breathing and a medic, SOLDIER-01, was summoned. SOLDIER-01 treated the detainee and while in the Hard Site observed the “human pyramid” of naked detainees with bags over their heads. SOLDIER-01 failed to report this abuse. These detainees were not MI Holds and MI involvement in this abuse has not been alleged nor is it likely. SOLDIER-29 reported seeing a screen saver for a computer in the Hard Site that depicted several naked detainees stacked in a “pyramid.” She also once observed, unrelated to this incident, CPL Graner slap a detainee. She stated that she didn’t report the picture of naked detainees to MI because she did not see it again and also did not report the slap because she didn’t consider it abuse (Reference Annex B, Appendix 1, SOLDIER-29; Annex B, Appendix 3, DETAINEE-01, DETAINEE-17, DETAINEE-16, ENGLAND, DAVIS, HARMAN, SIVITS, WISDOM; Annex B, Appendix 3, TAB A, SOLDIER-01, and Annex I, Appendix 1, Photographs C24-42, D22-25, M73-77, M87).

(12) (U) **Incident #12.** A photograph taken circa 27 December 2003, depicts a naked DETAINEE-14, apparently shot with a shotgun in his buttocks. This photograph could not be tied to a specific incident, detainee, or allegation and MI involvement is indeterminate (Reference Annex I, Appendix 1, Photographs D37-38, H2, M111).

(13) (U) **Incident #13.** Three photographs taken on 29 November 2003, depict an unidentified detainee dressed only in his underwear, standing with each foot on a separate box, and bent over at the waist. This photograph could not be tied to a specific incident, detainee, or allegation and MI involvement is indeterminate. (Reference Annex I, Appendix 1, Photographs D37-38, M111)

(14) (U) **Incident #14.** An 18 November 2003 photograph depicts a detainee dressed in a shirt or blanket lying on the floor with a banana inserted into his anus. This as well as several others show the same detainee covered in feces, with his hands encased in sandbags, or tied in foam and between two stretchers. These are all identified as DETAINEE-25 and were determined by CID investigation to be self-inflicted incidents. Even so, these incidents constitute abuse; a detainee with a known mental condition should not have been provided the banana or photographed. The detainee has a severe mental problem and the restraints depicted in these photographs were allegedly used to prevent the detainee from sodomizing himself and assaulting himself and others with his bodily fluids. He was known for inserting various objects

SUBJECT: (U) AR 15-6 Investigation of the Abu Ghraib Detention Facility and
205th MI Brigade

into his rectum and for consuming and throwing his urine and feces. MI had no association with this detainee (Reference Annex C; Annex E; Annex I, Appendix 1, Photographs, C22-23, D28-36, D39, M97-99, M105-110, M131-133).

(15) (U) **Incident #15.** On 26 or 27 November 2003, SOLDIER-15, 66 MI GP, observed CIVILIAN-11, a CACI contractor, interrogating an Iraqi policeman. During the interrogation, SSG Frederick, 372 MP CO, alternated between coming into the cell and standing next to the detainee and standing outside the cell. CIVILIAN-11 would ask the policeman a question stating that if he did not answer, he would bring SSG Frederick back into the cell. At one point, SSG Frederick put his hand over the policeman's nose, not allowing him to breathe for a few seconds. At another point SSG Frederick used a collapsible nightstick to push and possibly twist the policeman's arm, causing pain. When SSG Frederick walked out of the cell, he told SOLDIER-15 he knew ways to do this without leaving marks. SOLDIER-15 did not report the incident. The interpreter utilized for this interrogation was CIVILIAN-16. (Reference Annex B, Appendix 1, SOLDIER-15)

(16) (U) **Incident #16.** On an unknown date, SGT Hernandez, an analyst, observed CIVILIAN-05, a CACI contractor, grab a detainee from the back of a High-Mobility, Multipurpose, Wheeled Vehicle (HMMWV) and drop him on the ground. CIVILIAN-05 then dragged the detainee into an interrogation booth. The detainee was handcuffed the entire time. When the detainee tried to get up to his knees, CIVILIAN-05 would force him to fall. SGT Hernandez reported the incident to CID but did not report it in MI channels. (Reference Annex B, Appendix 1, HERNANDEZ)

(17) (U) **Incident #17.** A 30 November 2003, MP Log entry described an unidentified detainee found in a cell covered in blood. This detainee had assaulted CPL Graner, 372 MP CO, while they moved him to an isolation cell in Tier 1A. CPL Graner and CPL Kamauf, subdued the detainee, placed restraints on him and put him in an isolation cell. At approximately 0320 hours, 30 November 2003, after hearing banging on the isolation cell door, the cell was checked and the detainee was found in the cell standing by the door covered in blood. This detainee was not an MI Hold and there is no record of MI association with this incident or detainee. (Reference Annex I, Appendix 1, Photographs M115-129, M134).

(18) (U) **Incident #18.** On approximately 12 or 13 December 2003, DETAINEE-06 claimed numerous abuse incidents against US Soldiers. DETAINEE-06 was a Syrian foreign fighter and self-proclaimed Jihadist who came to Iraq to kill Coalition troops. DETAINEE-06 stated the Soldiers supposedly retaliated against him when he returned to the Hard Site after being released from the hospital following a shooting incident in which he attempted to kill US Soldiers. DETAINEE-06 had a pistol smuggled into him by an Iraqi Policeman and used that pistol to try to kill US personnel working in the Hard Site on 24 November 2003. An MP

SUBJECT: (U) AR 15-6 Investigation of the Abu Ghraib Detention Facility and
205th MI Brigade

returned fire and wounded DETAINEE-06. Once DETAINEE-06 ran out of ammunition, he surrendered and was transported to the hospital. DETAINEE-06 claimed CIVILIAN-21 visited him in the hospital and threatened him with terrible torture upon his return. DETAINEE-06 claimed that upon his return to the Hard Site, he was subjected to various threats and abuses which included Soldiers threatening to torture and kill him, being forced to eat pork and having liquor put in his mouth, having a "very hot" substance put in his nose and on his forehead, having the guards hit his "broken" leg several times with a solid plastic stick, being forced to "curse" his religion, being urinated on, being hung by handcuffs from the cell door for hours, being "smacked" on the back of the head, and "allowing dogs to try to bite" him. This claim was substantiated by a medic, SOLDIER-20, who was called to treat a detainee (DETAINEE-06) who had been complaining of pain. When SOLDIER-20 arrived DETAINEE-06 was cuffed to the upper bunk so that he could not sit down and CPL Graner was poking at his wounded legs with an asp with DETAINEE-06 crying out in pain. SOLDIER-20 provided pain medication and departed. He returned the following day to find DETAINEE-06 again cuffed to the upper bunk and a few days later returned to find him cuffed to the cell door with a dislocated shoulder. SOLDIER-20 failed to either stop or report this abuse. DETAINEE-06 also claimed that prior to the shooting incident, which he described as when "I got shot with several bullets" without mentioning that he ever fired a shot, he was threatened "every one or two hours... with torture and punishment", was subjected to sleep deprivation by standing up "for hours and hours", and had a "black man" tell him he would rape DETAINEE-06 on two occasions. Although DETAINEE-06 stated that CPL Graner led "a number of Soldiers" into his cell, he also stated that he had never seen CPL Graner beat a prisoner. These claims are from a detainee who attempted to kill US service members. While it is likely some Soldiers treated DETAINEE-06 harshly upon his return to the Hard Site, DETAINEE-06's accusations are potentially the exaggerations of a man who hated Americans. (Reference Annex B, Appendix 3, DETAINEE-06, SOLDIER-20).

(19) (U) **Incident #19.** SGT Adams, 470 MI GP, stated that sometime between 4 and 13 December 2003, several weeks after the shooting of "a detainee who had a pistol" (DETAINEE-06), she heard he was back from the hospital, and she went to check on him because he was one of the MI Holds she interrogated. She found DETAINEE-06 without clothes or blanket, his wounds were bleeding and he had a catheter on without a bag. The MPs told her they had no clothes for the detainee. SGT Adams ordered the MPs to get the detainee some clothes and went to the medical site to get the doctor on duty. The doctor (Colonel) asked what SGT Adams wanted and was asked if he was aware the detainee still had a catheter on. The Colonel said he was, the Combat Army Surgical Hospital (CASH) had made a mistake, and he couldn't remove it because the CASH was responsible for it. SGT Adams told him this was unacceptable, he again refused to remove it and stated the detainee was due to go back to the CASH the following day. SGT Adams asked if he had ever heard of the Geneva Conventions, and the Colonel responded "fine Sergeant, you do what you have to do, I am going back to bed."

SUBJECT: (U) AR 15-6 Investigation of the Abu Ghraib Detention Facility and
205th MI Brigade

(U) It is apparent from this incident that DETAINEE06 did not receive proper medical treatment, clothing or bedding. The "Colonel" has not been identified in this investigation, but efforts continue. LTC Akerson was chief of the medical team for "security holds" at Abu Ghraib from early October to late December 2003. He treated DETAINEE06 following his shooting and upon his return from the hospital. He did not recall such an incident or DETAINEE06 having a catheter. It is possible SGT Adams was taken to a different doctor that evening. She asked and was told the doctor was a Colonel, not a Lieutenant Colonel and is confident she can identify the Colonel from a photograph. LTC Akerson characterized the medical records as being exceptional at Abu Ghraib, however, the records found by this investigation were poor and in most cases non-existent. (Reference Annex B, Appendix 1, ADAMS, AKERSON; Annex B, Appendix 3, DETAINEE-06).

(20) (U) **Incident #20.** During the fall of 2003, a detainee stated that another detainee, named DETAINEE-09, was stripped, forced to stand on two boxes, had water poured on him and had his genitals hit with a glove. Additionally, the detainee was handcuffed to his cell door for a half day without food or water. The detainee making the statement did not recall the exact date or participants. Later, "Assad" was identified as DETAINEE-09, who stated that on 5 November 2003 he was stripped naked, beaten, and forced to crawl on the floor. He was forced to stand on a box and was hit in his genitals. The participants in this abuse could not be determined. MI involvement is indeterminate. (Reference Annex B, Appendix 3, DETAINEE-09; Annex I, Appendix 1, Photographs D37-38, M111)

(21) (U) **Incident #21.** Circa October 2003, CIVILIAN-17, an interpreter of the Titan Corporation, observed the following incident: CPL Graner, 372 MP CO, pushed a detainee, identified as one of the "three stooges" or "three wise men", into a wall, lacerating the detainee's chin. CIVILIAN-17 specifically stated the detainee was pushed into a wall and "busted his chin." A medic, SGT Wallin, stated he was summoned to stitch the detainee and treated a 2.5 inch laceration on the detainee's chin requiring 13 stitches. SGT Wallin did not know how the detainee was injured. Later that evening, CPL Graner took photos of the detainee. CPL Graner was identified in another incident where he stitched an injured detainee in the presence of medics. There is no indication of MI involvement, knowledge, or direction of this abuse. (Reference Annex B, Appendix 1, CIVILIAN-17; Annex B, Appendix 3, CIVILIAN-17, WALLIN, DETAINEE-02; Annex I, Appendix 1, Photographs M88-96).

(22) (U) **Incident #22.** On an unknown date, an interpreter named "CIVILIAN-01" allegedly raped a 15-18 year old male detainee according to DETAINEE-05. DETAINEE-05 heard screaming and climbed to the top of his cell door to see over a sheet covering the door of the cell where the abuse was occurring. DETAINEE-05 observed CIVILIAN-01, who was wearing a military uniform, raping the detainee. A female Soldier was taking pictures.

SUBJECT: (U) AR 15-6 Investigation of the Abu Ghraib Detention Facility and
205th MI Brigade

DETAINEE-05 described CIVILIAN-01 as possibly Egyptian, “not skinny or short,” and effeminate. The date and participants of this alleged rape could not be confirmed. No other reporting supports DETAINEE-05’s allegation, nor have photographs of the rape surfaced. A review of all available records could not identify a translator by the name of CIVILIAN-01. DETAINEE05’s description of the interpreter partially matches CIVILIAN-17, Interpreter, Titan Corp. CIVILIAN-17 is a large man, believed by several witnesses to be homosexual, and of Egyptian extraction. CIVILIAN-17 functioned as an interpreter for a Tactical HUMINT Team at Abu Ghraib, but routinely provided translation for both MI and MP. CID has an open investigation into this allegation. (Reference Annex B, Appendix 3, DETAINEE-05)

(23) (U) **Incident #23.** On 24 November 2003, a US Army officer, CPT Brinson, MP, allegedly beat and kicked a detainee. This is one of three identified abuses associated with the 24 November shooting. A detainee obtained a pistol from Iraqi police guards, shot an MP and was subsequently shot and wounded. During a subsequent search of the Hard Site and interrogation of detainees, SGT Spiker, 229 MP CO, a member of the Abu Ghraib Internal Reaction Force (IRF), observed an Army Captain dragging an unidentified detainee in a choke hold, throwing him against a wall, and kicking him in the mid-section. SPC Polak, 229 MP CO, IRF was also present in the Hard Site and observed the same abuse involving two Soldiers and a detainee. The detainee was lying on his stomach with his hands cuffed behind his back and a bag over his head. One Soldier stood next to him with the barrel of a rifle pressed against the detainee’s head. The other Soldier was kneeling next to the detainee punching him in the back with a closed fist. The Soldier then stood up and kicked the detainee several times. The Soldier inflicting the beating was described as a white male with close cropped blond hair. SPC Polak saw this Soldier a few days later in full uniform, identifying him as a Captain, but could not see his name. Both SPC Polak and SGT Spiker reported this abuse to their supervisors, SFC Plude and 1LT Sutton, 372 MP CO. Photos of company grade officers at Abu Ghraib during this time were obtained and shown to SPC Polak and SGT Spiker, who positively identified the “Captain” as CPT Brinson. This incident was investigated by CID and the assault was determined to be unfounded; a staged event to protect the fact the detainee was a cooperative MP Source. (Reference Annex B, Appendix 1, PLUDE, POLAK, SPIKER, SUTTON; Annex B, Appendix 3, PLUDE, SUTTON; Annex E, Appendix 5, CID Report of Investigation 0005-04-CID149-83131)

(24) (U) **Incident #24.** A photograph created circa early December 2003 depicts an unidentified detainee being interrogated by CIVILIAN-11, CACI, Interrogator, and CIVILIAN-16, Titan, linguist. The detainee is squatting on a chair which is an unauthorized stress position. Having the detainee on a chair which is a potentially unsafe situation, and photographing the detainee are violations of the ICRP. (Reference Annex I, Appendix 2, Photograph “Stress Position”).

SUBJECT: (U) AR 15-6 Investigation of the Abu Ghraib Detention Facility and
205th MI Brigade

f. (U) Incidents of Detainee Abuse Using Dogs. (U) Abusing detainees with dogs started almost immediately after the dogs arrived at Abu Ghraib on 20 November 2003. By that date, abuses of detainees was already occurring and the addition of dogs was just one more abuse device. Dog Teams were brought to Abu Ghraib as a result of recommendations from MG G. Miller's assessment team from JTF-GTMO. MG G. Miller recommended dogs as beneficial for detainee custody and control issues, especially in instances where there were large numbers of detainees and few guards to help reduce the risk of detainee demonstrations or acts of violence, as at Abu Ghraib. MG G. Miller never recommended, nor were dogs used for interrogations at GTMO. The dog teams were requested by COL Pappas, Commander, 205 MI BDE. COL Pappas never understood the intent as described by MG G. Miller. Interrogations at Abu Ghraib were also influenced by several documents that spoke of exploiting the Arab fear of dogs: a 24 January 2003 "CJTF 180 Interrogation Techniques," an 11 October 2002 JTF 170 "Counter-Resistance Strategies," and a 14 September 2003 CJTF-7 ICRP. Once the dogs arrived, there was controversy over who "owned" the dogs. It was ultimately decided that the dogs would be attached to the Internal Reaction Force (IRF). The use of dogs in interrogations to "fear up" detainees was generally unquestioned and stems in part from the interrogation techniques and counter-resistance policy distributed from CJTF 180, JTF 170 and CJTF-7. It is likely the confusion about using dogs partially stems from the initial request for dog teams by MI, not MPs, and their presence being associated with MG G. Miller's visit. Most military intelligence personnel believed that the use of dogs in interrogations was a "non-standard" technique which required approval, and most also believed that approval rested with COL Pappas. COL Pappas also believed, incorrectly, that he had such authority delegated to him from LTG Sanchez. COL Pappas's belief likely stemmed in part from the changing ICRP. The initial policy was published on 14 September 2003 and allowed the use of dogs subject to approval by LTG Sanchez. On 12 October 2003, these were amended to eliminate several techniques due to CENTCOM objections. After the 12 October 2003 amendment, the ICRP safeguards allowed that dogs present at interrogations were to be muzzled and under the control of a handler. COL Pappas did not recall how he got the authority to employ dogs; just that he had it. (Reference Annex B, Appendix 1, G. MILLER and PAPPAS, and Annex J, Appendix 3)

(U) SFC Plude stated the two Army dog teams never joined the Navy teams as part of the IRF and remained separate and under the direct control of MAJ Dinenna, S3, 320 MP BN. These teams were involved in all documented detainee abuse involving dogs; both MP and MI directed. The Navy dog teams were properly employed because of good training, excellent leadership, personal moral character, and professionalism exhibited by the Navy Dog Handlers, MA1 Kimbro, MA1 Clark, and MA2 Pankratz, and IRF personnel. The Army teams apparently agreed to be used in abusive situations by both MPs and MI in contravention to their doctrine, training, and values. In an atmosphere of permissiveness and absence of oversight or leadership the Army dog teams became involved in several incidents of abuse over the following weeks

SUBJECT: (U) AR 15-6 Investigation of the Abu Ghraib Detention Facility and
205th MI Brigade

(Reference Annex B, Appendix 1, KIMBRO, PLUDE; Annex B, Appendix 2, PLUDE; Annex B, Appendix 3, PLUDE).

(1) (U) **Incident #25.** The first documented incident of abuse with dogs occurred on 24 November 2003, just four days after the dogs teams arrived. An Iraqi detainee was smuggled a pistol by an Iraqi Police Guard. While attempting to confiscate the weapon, an MP was shot and the detainee was subsequently shot and wounded. Following the shooting, LTC Jordan ordered several interrogators to the Hard Site to screen eleven Iraqi Police who were detained following the shooting. The situation at the Hard Site was described by many as “chaos,” and no one really appeared to be in charge. The perception was that LTG Sanchez had removed all restrictions that night because of the situation; however, that was not true. No one is able to pin down how that perception was created. A Navy Dog Team entered the Hard Site and was instructed to search for additional weapons and explosives. The dogs searched the cells, no explosives were detected and the Navy Dog Team eventually completed their mission and left. Shortly thereafter, MA1 Kimbro, USN, was recalled when someone “needed” a dog. MA1 Kimbro went to the top floor of Tier 1B, rather than the MI Hold area of Tier 1A. As he and his dog approached a cell door, he heard yelling and screaming and his dog became agitated. Inside the cell were CIVILIAN-11 (CACI contract interrogator), a second unidentified male in civilian clothes who appeared to be an interrogator and CIVILIAN16 (female contract interpreter), all of whom were yelling at a detainee squatting in the back right corner. MA1 Kimbro’s dog was barking a lot with all the yelling and commotion. The dog lunged and MA1 Kimbro struggled to regain control of it. At that point, one of the men said words to the effect “You see that dog there, if you don’t tell me what I want to know, I’m gonna get that dog on you!” The three began to step out of the cell leaving the detainee inside and MA1 Kimbro backed-up to allow them to exit, but there was not much room on the tier. After they exited, the dog lunged and pulled MA1 Kimbro just inside the cell. He quickly regained control of his dog, and exited the cell. As CIVILIAN-11, CIVILIAN-16, and the other interrogator re-entered the cell, MA1 Kimbro’s dog grabbed CIVILIAN-16’s forearm in its mouth. It apparently did not bite through her clothes or skin and CIVILIAN-16 stated the dog did not bite her. Realizing he had not been called for an explosives search, MA1 Kimbro departed the area with his dog and as he got to the bottom of the tier stairs, he heard someone calling for the dog again, but he did not return. No record of this interrogation exists, as was the case for the interrogations of Iraqi Police in the hours and days following the shooting incident. The use of dogs in the manner directed by CIVILIAN-11 was clearly abusive and unauthorized (Reference Annex B, Appendix 1, SOLDIER-11, KIMBRO, PAPPAS, CIVILIAN-11; Annex B, Appendix 2, PAPPAS).

(U) Even with all the apparent confusion over roles, responsibilities and authorities, there were early indications that MP and MI personnel knew the use of dog teams in interrogations was abusive. Following this 24 November 2003, incident the three Navy dog teams concluded that some interrogators might attempt to misuse Navy Dogs to support their

SUBJECT: (U) AR 15-6 Investigation of the Abu Ghraib Detention Facility and
205th MI Brigade

interrogations. For all subsequent requests they inquired what the specific purpose of the dog was and when told "for interrogation" they explained that Navy dogs were not intended for interrogations and the request would not be fulfilled. Over the next few weeks, the Navy dog teams received about eight similar calls, none of which were fulfilled. In the later part of December 2003, COL Pappas summoned MA1 Kimbro and wanted to know what the Navy dogs' capabilities were. MA1 Kimbro explained Navy dog capabilities and provided the Navy Dog Use SOP. COL Pappas never asked if they could be used in interrogations and following that meeting the Navy Dog teams received no additional requests to support interrogations.

(2) (U) **Incident #26.** On or about 8 January 2004, SOLDIER-17 was conducting an interrogation of a Baath Party General Officer in the shower area of Tier 1B of the Hard Site. Tier 1B was the area of the Hard Site dedicated to female and juvenile detainees. Although Tier 1B was not the normal location for interrogations, due to a space shortage in Tier 1A, SOLDIER-17 was using this area. SOLDIER-17 witnessed an MP guard and an MP Dog Handler, whom SOLDIER-17 later identified from photographs as SOLDIER27, enter Tier 1B with SOLDIER-27's black dog. The dog was on a leash, but was not muzzled. The MP guard and MP Dog Handler opened a cell in which two juveniles, one known as "Casper," were housed. SOLDIER-27 allowed the dog to enter the cell and "go nuts on the kids," barking at and scaring them. The juveniles were screaming and the smaller one tried to hide behind "Casper." SOLDIER-27 allowed the dog to get within about one foot of the juveniles. Afterward, SOLDIER-17 overheard SOLDIER-27 say that he had a competition with another handler (likely SOLDIER-08, the only other Army dog handler) to see if they could scare detainees to the point that they would defecate. He mentioned that they had already made some detainees urinate, so they appeared to be raising the competition. This incident has no direct MI involvement; however, SOLDIER-17 failed to properly report what he observed. He stated that he went to bed and forgot the incident until asked about misuse of dogs during this investigation (Reference Annex B, Appendix 1, SOLDIER-17).

(3) (U) **Incident #27.** On 12 December 2003, an MI Hold detainee named DETAINEE-11, was recommended by MI (SOLDIER-17) for an extended stay in the Hard Site because he appeared to be mentally unstable. He was bitten by a dog in the Hard Site, but at the time he was not undergoing an interrogation and no MI personnel were present. DETAINEE-11 told SOLDIER-17 that a dog had bitten him and SOLDIER-17 saw dog bite marks on DETAINEE11's thigh. SOLDIER-08, who was the dog handler of the dog that bit DETAINEE-11, stated that in December 2003 his dog bit a detainee and he believed that MPs were the only personnel around when the incident occurred, but he declined to make further statements regarding this incident to either the MG Taguba inquiry or to this inquiry. SOLDIER-27, another Army dog handler, also stated that SOLDIER-08's dog had bitten someone, but did not provide further information. This incident was captured on digital photograph 0178/CG LAPS and appears to be the result of MP harassment and amusement, no MI involvement is suspected

SUBJECT: (U) AR 15-6 Investigation of the Abu Ghraib Detention Facility and
205th MI Brigade

(Reference Annex B, Appendix 1, SOLDIER-17; Annex B, Appendix 2, SOLDIER-08, SMITH;
Annex I, Appendix 1, Photographs, D45-54, M146-171).

(4) (U) **Incident #28.** In an apparent MI directed use of dogs in detainee abuse, circa 18 December 2003, a photograph depicts a Syrian detainee (DETAINEE-14) kneeling on the floor with his hands bound behind his back. DETAINEE-14 was a "high value" detainee who had arrived at Abu Ghraib in December 2003, from a Navy ship. DETAINEE-14 was suspected to be involved with Al-Qaeda. Military Working Dog Handler SOLDIER-27 is standing in front of DETAINEE-14 with his black dog a few feet from DETAINEE-14's face. The dog is leashed, but not muzzled. SGT Eckroth was DETAINEE-14's interrogator from 18 to 21 December 2003, and CIVILIAN-21, CACI contract interrogator, assumed the lead after SGT Eckroth departed Abu Ghraib on 22 December 2003. SGT Eckroth identified DETAINEE14 as his detainee when shown a photo of the incident. CIVILIAN-21 claimed to know nothing about this incident; however, in December 2003 he related to SSG Eckroth he was told by MPs that DETAINEE-14's bedding had been ripped apart by dogs. CIVILIAN-21 was characterized by SOLDIER25 as having a close relationship with the MPs, and she was told by SGT Frederick about dogs being used when CIVILIAN-21 was there. It is highly plausible that CIVILIAN-21 used dogs without authorization and directed the abuse in this incident as well as others related to this detainee (Reference Annex B, Appendix 1, ECKROTH, SOLDIER25, CIVILIAN-21; Annex I, Appendix 1, Photographs Z1-6).

(5) (U) **Incident #29.** On or about 14 - 15 December 2003, dogs were used in an interrogation. SPC Aston, who was the Section Chief of the Special Projects team, stated that on 14 December, one of his interrogation teams requested the use of dogs for a detainee captured in conjunction with the capture of Saddam Hussein on 13 December 2003. SPC Aston verbally requested the use of dogs from COL Pappas, and COL Pappas stated that he would call higher to request permission. This is contrary to COL Pappas's statement that he was given authority to use dogs as long as they were muzzled. About one hour later, SPC Aston received approval. SPC Aston stated that he was standing to the side of the dog handler the entire time the dog was used in the interrogation. The dog never hurt anyone and was always muzzled, about five feet away from the detainee (Reference Annex B, Appendix 1, ASTON, PAPPAS).

(6) (U) **Incident #30.** On another occasion, SOLDIER-26, an MI Soldier assigned to the S2, 320 MP BN, was present during an interrogation of a detainee and was told the detainee was suspected to have Al Qaeda affiliations. Dogs were requested and approved about three days later. SOLDIER-26 didn't know if the dog had to be muzzled or not, likely telling the dog handler to un-muzzle the dog, in contravention to CJTF-7 policy. The interrogators were CIVILIAN-20, CACI, and CIVILIAN-21 (CACI), SOLDIER-14, Operations Officer, ICE stated that CIVILIAN-21, used a dog during one of his interrogations and this is likely that occasion. According to SOLDIER-14, CIVILIAN-21 had the dog handler maintain control of the dog and

SUBJECT: (U) AR 15-6 Investigation of the Abu Ghraib Detention Facility and
205th MI Brigade

did not make any threatening reference to the dog, but apparently “felt just the presence of the dog would be unsettling to the detainee.” SOLDIER-14 did not know who approved the procedure, but was verbally notified by SOLDIER-23, who supposedly received the approval from COL Pappas. CIVILIAN-21 claimed he once requested to use dogs, but it was never approved. Based on the evidence, CIVILIAN-21 was deceitful in his statement (Reference Annex B, Appendix 1, SOLDIER-14, SOLDIER-26, CIVILIAN-21).

(7) (U) **Incident #31.** In a 14/15 December 2003 interrogation, military working dogs were used but were deemed ineffective because the detainee had little to no response to them. CIVILIAN-11, SOLDIER-05 and SOLDIER-12, all who participated in the interrogation, believed they had authority to use the dogs from COL Pappas or from LTG Sanchez; however, no documentation was found showing CJTF7 approval to use dogs in interrogations. It is probable that approval was granted by COL Pappas without such authority. LTG Sanchez stated he never approved use of dogs. (Reference Annex B, Appendix 1, CIVILIAN-11, SOLDIER-12, SOLDIER-14, PAPPAS, SOLDIER-23, CIVILIAN-21, SANCHEZ).

(8) (U) **Incident #32.** In yet another instance, SOLDIER-25, an interrogator, stated that when she and SOLDIER-15 were interrogating a female detainee in the Hard Site, they heard a dog barking. The female detainee was frightened by dogs, and SOLDIER-25 and SOLDIER-15 returned her to her cell. SOLDIER-25 went to see what was happening with the dog barking and saw a detainee in his underwear on a mattress on the floor of Tier 1A with a dog standing over him. CIVILIAN-21 was upstairs giving directions to SSG Fredrick (372 MP Co), telling him to “take him back home.” SOLDIER-25 opined it was “common knowledge that CIVILIAN-21 used dogs while he was on special projects, working directly for COL Pappas after the capture of Saddam on 13 December 2003.” SOLDIER-25 could not identify anyone else specifically who knew of this “common knowledge.” It appeared CIVILIAN-21 was encouraging and even directing the MP abuse with dogs; likely a “softening up” technique for future interrogations. The detainee was one of CIVILIAN-21’s. SOLDIER-25 did not see an interpreter in the area, so it is unlikely that CIVILIAN-21 was actually doing an interrogation.

(9) (U) SOLDIER-25 stated that SSG Frederick would come into her office every other day or so and tell her about dogs being used while CIVILIAN-21 was present. SSG Frederick and other MPs used to refer to “doggy dance” sessions. SOLDIER-25 did not specify what “doggy dance” was (Reference Annex B, Appendix 1, SOLDIER-25), but the obvious implication is that it referred to an unauthorized use of dogs to intimidate detainees.

g. (U) Incidents of Detainee Abuse Using Humiliation. Removal of clothing was not a technique developed at Abu Ghraib, but rather a technique which was imported and can be traced through Afghanistan and GTMO. The 1987 version of FM 34-52, Interrogation, talked about “controlling all aspects of the interrogation to include... clothing given to the source,” while the

SUBJECT: (U) AR 15-6 Investigation of the Abu Ghraib Detention Facility and
205th MI Brigade

current 1992 version does not. The 1987 version was, however, cited as the primary reference for CJTF-7 in Iraq, even as late as 9 June 2004. The removal of clothing for both MI and MP objectives was authorized, approved, and employed in Afghanistan and GTMO. At GTMO, the JTF 170 "Counter-Resistance Strategy," documented on 11 October 2002, permitted the removal of clothing, approved by the interrogation officer-in-charge, as an incentive in detention operations and interrogations. The SECDEF granted this authority on 2 December 2002, but it was rescinded six weeks later in January 2003. This technique also surfaced in Afghanistan. The CJTF-180 "Interrogation Techniques," documented on 24 January 2003, highlighted that deprivation of clothing had not historically been included in battlefield interrogations. However, it went on to recommend clothing removal as an effective technique that could potentially raise objections as being degrading or inhumane, but for which no specific written legal prohibition existed. As interrogation operations in Iraq began to take form, it was often the same personnel who had operated and deployed in other theaters and in support of GWOT, who were called upon to establish and conduct interrogation operations in Abu Ghraib. The lines of authority and the prior legal opinions blurred. Soldiers simply carried forward the use of nudity into the Iraqi theater of operations.

(U) Removal of clothing is not a doctrinal or authorized interrogation technique but appears to have been directed and employed at various levels within MI as an "ego down" technique. It was also employed by MPs as a "control" mechanism. Individual observation and/or understanding of the use and approval of clothing removal varied in each interview conducted by this investigation. LTC Jordan was knowledgeable of naked detainees and removal of their clothing. He denied ordering it and blamed it on the MPs. CPT Wood and SOLDIER14 claimed not to have observed nudity or approved clothing removal. Multiple MPs, interrogators, analysts, and interpreters observed nudity and/or employed clothing removal as an incentive, while an equal number didn't. It is apparent from this investigation that removal of clothing was employed routinely and with the belief it was not abuse. SOLDIER-03, GTMO Tiger Team believed that clothing as an "ego down" technique could be employed. He thought, mistakenly, that GTMO still had that authority. Nudity of detainees throughout the Hard Site was common enough that even during an ICRC visit they noted several detainees without clothing, and CPT Reese, 372 MP CO, stated upon his initial arrival at Abu Ghraib, "There's a lot of nude people here." Some of the nudity was attributed to a lack of clothing and uniforms for the detainees; however, even in these cases we could not determine what happened to the detainee's original clothing. It was routine practice to strip search detainees before their movement to the Hard Site. The use of clothing as an incentive (nudity) is significant in that it likely contributed to an escalating "de-humanization" of the detainees and set the stage for additional and more severe abuses to occur (Reference Annex I, Appendix 1, Photographs D42-43, M5-7, M17-18, M21, M137-141).

SUBJECT: (U) AR 15-6 Investigation of the Abu Ghraib Detention Facility and
205th MI Brigade

(1) (U) **Incident #33.** There is also ample evidence of detainees being forced to wear women's underwear, sometimes on their heads. These cases appear to be a form of humiliation, either for MP control or MI "ego down." DETAINEE-07 and DETAINEE-05 both claimed they were stripped of their clothing and forced to wear women's underwear on their heads. CIVILIAN-15 (CACI) and CIVILIAN-19 (CACI), a CJTF-7 analyst, alleged CIVILIAN-21 bragged and laughed about shaving a detainee and forcing him to wear red women's underwear. Several photographs include unidentified detainees with underwear on their heads. Such photos show abuse and constitute sexual humiliation of detainees (Reference Annex B, Appendix 1, SOLDIER-03, SOLDIER-14, JORDAN, REESE, CIVILIAN-21, WOOD; Annex B, Appendix 3, DETAINEE-05, CIVILIAN-15, CIVILIAN-19, DETAINEE-07; Annex C; Annex G; Annex I, Appendix 1, photographs D12, D14, M11-16).

(2) (U) **Incident #34.** On 16 September 2003, MI directed the removal of a detainee's clothing. This is the earliest incident we identified at Abu Ghraib. An MP log indicated a detainee "was stripped down per MI and he is naked (sic) and standing tall in his cell." The following day his interrogators, SPC Webster and SSG Clinscales, arrived at the detainee's cell, and he was unclothed. They were both surprised. An MP asked SSG Clinscales, a female, to stand to the side while the detainee dressed and the detainee appeared to have his clothing in his cell. SSG Clinscales was told by the MP the detainee had voluntarily removed his clothing as a protest and, in the subsequent interrogation, the detainee did not claim any abuse or the forcible removal of his clothing. It does not appear the detainee was stripped at the interrogator's direction, but someone in MI most likely directed it. SPC Webster and SOLDIER-25 provided statements where they opined SPC Claus, in charge of in-processing MI Holds, may have directed removal of detainee clothing on this and other occasions. SPC Claus denies ever giving such orders (Reference Annex B, Appendix 1, CLAUS, CLINSCALES, SOLDIER-25, WEBSTER).

(3) (U) **Incident #35.** On 19 September 2003, an interrogation "Tiger Team" consisting of SOLDIER-16, SOLDIER-07, and a civilian contract interpreter identified only as "Maher" (female), conducted a late night/early morning interrogation of a 17 year old Syrian foreign fighter. SOLDIER-16 was the lead interrogator. SOLDIER-07 was told by SOLDIER-16 that the detainee they were about to interrogate was naked. SOLDIER-07 was unsure if SOLDIER-16 was simply passing along that fact or had directed the MPs to strip the detainee. The detainee had fashioned an empty "Meals-Ready-to-Eat" (MRE) bag to cover his genital area. SOLDIER-07 couldn't recall who ordered the detainee to raise his hands to his sides, but when he did, the bag fell to the floor exposing him to SOLDIER-07 and the two female interrogation team members. SOLDIER-16 used a direct interrogation approach with the incentive of getting back clothing, and the use of stress positions.

SUBJECT: (U) AR 15-6 Investigation of the Abu Ghraib Detention Facility and
205th MI Brigade

(U) There is no record of an Interrogation Plan or any approval documents which would authorize these techniques. The fact these techniques were documented in the Interrogation Report suggests, however, that the interrogators believed they had the authority to use clothing as an incentive, as well as stress positions, and were not attempting to hide their use. Stress positions were permissible with Commander, CJTF-7 approval at that time. It is probable that use of nudity was sanctioned at some level within the chain-of-command. If not, lack of leadership and oversight permitted the nudity to occur. Having a detainee raise his hands to expose himself in front of two females is humiliation and therefore violates the Geneva Conventions (Reference Annex B, Appendix 1, SOLDIER-07, SOLDIER-14, SOLDIER-16, SOLDIER-24, WOOD).

(4) (U) **Incident #36.** In early October 2003, SOLDIER-19 was conducting an interrogation and ordered a detainee to roll his orange jumpsuit down to his waist, insinuating to the detainee that he would be further stripped if he did not cooperate. SOLDIER-19's interpreter put up his hand, looked away, said that he was not comfortable with the situation, and exited the interrogation booth. SOLDIER-19 was then forced to stop the interrogation due to lack of language support. SOLDIER-11, an analyst from a visiting JTF GTMO Tiger Team, witnessed this incident through the booth's observation window and brought it to the attention of SOLDIER-16, who was SOLDIER-19's Team Chief and first line supervisor. SOLDIER-16 responded that SOLDIER-19 knew what he was doing and did not take any action regarding the matter. SOLDIER-11 reported the same information to SOLDIER-28, his JTF GTMO Tiger Team Chief, who, according to SOLDIER-11, said he would "take care of it." SOLDIER-28 recalled a conversation with SOLDIER-11 concerning an interpreter walking out of an interrogation due to a "cultural difference," but could not remember the incident. This incident has four abuse components: the actual unauthorized stripping of a detainee by SOLDIER-19, the failure of SOLDIER-10 to report the incident he witnessed, the failure of SOLDIER-16 to take corrective action, reporting the incident up the chain of command, and the failure of SOLDIER-28 to report. (Reference Annex B, Appendix 1, SOLDIER-11, SOLDIER-16, SOLDIER-19, SOLDIER-28)

(5) (U) **Incident #37.** A photograph taken on 17 October 2003 depicts a naked detainee chained to his cell door with a hood on his head. Several other photographs taken on 18 October 2003 depict a hooded detainee cuffed to his cell door. Additional photographs on 19 October 2003 depict a detainee cuffed to his bed with underwear on his head. A review of available documents could not tie these photos to a specific incident, detainee or allegation, but these photos reinforce the reality that humiliation and nudity were being employed routinely enough that photo opportunities occurred on three successive days. MI involvement in these apparent abuses cannot be confirmed. (Reference Annex I, Appendix 1, Photographs D12, D14, D42-44, M5-7, M17-18, M21, M11-16, M137-141)

SUBJECT: (U) AR 15-6 Investigation of the Abu Ghraib Detention Facility and
205th MI Brigade

(6) (U) **Incident #38.** Eleven photographs of two female detainees arrested for suspected prostitution were obtained. Identified in these photographs are SPC Harman and CPL Graner, both MPs. In some of these photos, a criminal detainee housed in the Hard Site was shown lifting her shirt with both her breasts exposed. There is no evidence to confirm if these acts were consensual or coerced; however in either case sexual exploitation of a person in US custody constitutes abuse. There does not appear to be any direct MI involvement in either of the two incidents above. (Reference Annex I, Appendix 1, Photographs M42-52)

(7) (U) **Incident #39.** On 16 November 2003, SOLDIER-29 decided to strip a detainee in response to what she believed was uncooperative and physically recalcitrant behavior. She had submitted an Interrogation Plan in which she planned to use the "Pride and Ego Down," technique but did not specify that she would strip the detainee as part of that approach. SOLDIER-29 felt the detainee was "arrogant," and when she and her analyst, SOLDIER-10, "placed him against the wall" the detainee pushed SOLDIER-10. SOLDIER-29 warned if he touched SOLDIER-10 again, she would have him remove his shoes. A bizarre tit-for-tat scenario then ensued where SOLDIER-29 would warn the detainee about touching SOLDIER-10, the detainee would "touch" SOLDIER-10, and then had his shirt, blanket, and finally his pants removed. At this point, SOLDIER-29 concluded that the detainee was "completely uncooperative" and terminated the interrogation. While nudity seemed to be acceptable, SOLDIER-29 went further than most when she walked the semi-naked detainee across the camp. SGT Adams, SOLDIER-29's supervisor, commented that walking a semi-naked detainee across the camp could have caused a riot. CIVILIAN-21, a CACI contract interrogator, witnessed SOLDIER-29 and SOLDIER-10 escorting the scantily clad detainee from the Hard Site back to Camp Vigilant, wearing only his underwear and carrying his blanket. CIVILIAN-21 notified SGT Adams, who was SOLDIER-29's section chief, who in turn notified CPT Wood, the ICE OIC. SGT Adams immediately called SOLDIER-29 and SOLDIER-10 into her office, counseled them, and removed them from interrogation duties.

(U) The incident was relatively well known among JIDC personnel and appeared in several statements as second hand information when interviewees were asked if they knew of detainee abuse. LTC Jordan temporarily removed SOLDIER-29 and SOLDIER-10 from interrogation duties. COL Pappas left the issue for LTC Jordan to handle. COL Pappas should have taken sterner action such as an Article 15, UCMJ. His failure to do so did not send a strong enough message to the rest of the JIDC that abuse would not be tolerated. CPT Wood had recommended to LTC Jordan that SOLDIER-29 receive an Article 15 and SFC Johnson, the interrogation NCOIC, recommended she be turned over to her parent unit for the non-compliance. (Reference Annex B, Appendix 1, ADAMS, CIVILIAN-04, JORDAN, PAPPAS, SOLDIER-29, CIVILIAN-21, WOOD; Annex B, Appendix 2, JORDAN).

SUBJECT: (U) AR 15-6 Investigation of the Abu Ghraib Detention Facility and
205th MI Brigade

(8) (U) **Incident #40.** On 24 November 2003, there was a shooting of a detainee at Abu Ghraib in Tier 1A. DETAINEE-06, had obtained a pistol. While the MPs attempted to confiscate the weapon, an MP and DETAINEE-06 were shot. It was alleged that an Iraqi Police Guard had smuggled the pistol to DETAINEE-06 and in the aftermath of the shooting forty-three Iraqi Police were screened and eleven subsequently detained and interrogated. All but three were released following intense questioning. A fourth did not report for work the next day and is still at large. The Iraqi guard detainees admitted smuggling the weapons into the facility hiding them in an inner tube of a tire and several of the Iraqi guards were identified as Fedayeen trainers and members. During the interrogations of the Iraqi Police, harsh and unauthorized techniques were employed to include the use of dogs, discussed earlier in this report, and removal of clothing (See paragraph 5.e(18), above). Once detained, the police were strip-searched, which was a reasonable precaution considering the threat of contraband or weapons. Following such search, however, the police were not returned their clothes before being interrogated. This is an act of humiliation and was unauthorized. It was the general understanding that evening that LTG Sanchez and COL Pappas had authorized all measures to identify those involved, however, that should not have been construed to include abuse. LTC Jordan was the senior officer present at the interrogations and is responsible for the harsh and humiliating treatment of the police (Reference Annex B, Appendix 1, JORDAN, PAPPAS; Annex B, Appendix 2, JORDAN, PAPPAS, Annex B, Appendix 1, DETAINEE-06).

(9) (U) **Incident #41.** On 4 December 2003, documentation in the MP Logs indicated that MI leadership was aware of clothing removal. An entry indicated "Spoke with LTC Jordan (205 MI BDE) about MI holds in Tier 1A/B. He stated he would clear up with MI and let MPs run Tiers 1A/B as far as what inmate gets (clothes)." Additionally, in his statement, LTC Phillabaum claims he asked LTC Jordan what the situation was with naked detainees, and LTC Jordan responded with, "It was an interrogation technique." Whether this supports allegations of MI involvement in the clothing and stripping of detainees is uncertain, but it does show that MI at least knew of the practice and was willing to defer decisions to the MPs. Such vague guidance, if later combined with an implied tasking from MI, or perceived tasking by MP, potentially contributed to the subsequent abuse (Reference Annex B, Appendix 2, PHILLABAUM).

h. (U) Incidents of Detainee Abuse Using Isolation. Isolation is a valid interrogation technique which required approval by the CJTF-7 Commander. We identified documentation of four instances where isolation was approved by LTG Sanchez. LTG Sanchez stated he had approved 25 instances of isolation. This investigation, however, found numerous incidents of chronic confusion by both MI and MPs at all levels of command, up through CJTF-7, between the definitions of "isolation" and "segregation." Since these terms were commonly interchanged, we conclude Segregation was used far more often than Isolation. Segregation is a valid procedure to limit collaboration between detainees. This is what was employed most often in Tier 1A (putting a detainee in a cell by himself vice in a communal cell as was common outside

SUBJECT: (U) AR 15-6 Investigation of the Abu Ghraib Detention Facility and
205th MI Brigade

the Hard Site) and was sometimes incorrectly referred to as “isolation.” Tier 1A did have isolation cells with solid doors which could be closed as well as a small room (closet) which was referred to as the isolation “Hole.” Use of these rooms should have been closely controlled and monitored by MI and MP leaders. They were not, however, which subjected the detainees to excessive cold in the winter and heat in the summer. There was obviously poor air quality, no monitoring of time limits, no frequent checks on the physical condition of the detainee, and no medical screening, all of which added up to detainee abuse. A review of interrogation reports identified ten references to “putting people in the Hole,” “taking them out of the Hole,” or consideration of isolation. These occurred between 15 September 2003 and 3 January 2004. (Reference Annex B, Appendix 1, SANCHEZ)

(1) (U) **Incident #42.** On 15 September 2003, at 2150 hours, unidentified MI personnel, using the initials CKD, directed the use of isolation on a unidentified detainee. The detainee in cell #9 was directed to leave his outer cell door open for ventilation and was directed to be taken off the light schedule. The identification of CKD, the MI personnel, or the detainee could not be determined. This information originated from the prison log entry and confirms the use of isolation and sensory deprivation as interrogation techniques. (Reference MP Hard Site log book entry, 15 September 2003).

(2) (U) **Incident #43.** In early October 2003, SOLDIER-11 was interrogating an unidentified detainee with SOLDIER-19, an interrogator, and an unidentified contract interpreter. About an hour and 45 minutes into the interrogation, SOLDIER-19 turned to SOLDIER-11 and asked if he thought they should place the detainee in solitary confinement for a few hours, apparently because the detainee was not cooperating or answering questions. SOLDIER-11 expressed his misgivings about the tactic, but deferred to SOLDIER-19 as the interrogator. About 15 minutes later, SOLDIER-19 stopped the interrogation, departed the booth, and returned about five minutes later with an MP, SSG Frederick. SSG Frederick jammed a bag over the detainee’s head, grabbed the handcuffs restraining him and said something like “come with me piggy”, as he led the detainee to solitary confinement in the Hard Site, Tier 1A of Abu Ghraib.

(U) About half an hour later, SOLDIER-19 and SOLDIER-11 went to the Hard Site without their interpreter, although he was available if needed. When they arrived at the detainee’s cell, they found him lying on the floor, completely naked except for a hood that covered his head from his upper lip, whimpering, but there were no bruises or marks on him. SSG Frederick then met SOLDIER-19 and SOLDIER-11 at the cell door. He started yelling at the detainee, “You’ve been moving little piggy, you know you shouldn’t move”, or words to that effect, and yanked the hood back down over the detainee’s head. SOLDIER-19 and SOLDIER-11 instructed other MPs to clothe the detainee, which they did. SOLDIER-11 then asked SOLDIER-19 if he knew the MPs were going to strip the detainee, and SOLDIER-19 said that he

SUBJECT: (U) AR 15-6 Investigation of the Abu Ghraib Detention Facility and
205th MI Brigade

did not. After the detainee was clothed, both SOLDIER-19 and SOLDIER-11 escorted him to the general population and released him without interrogating him again. SSG Frederick made the statement "I want to thank you guys, because up until a week or two ago, I was a good Christian." SOLDIER-11 is uncertain under what context SSG Frederick made this statement. SOLDIER-11 noted that neither the isolation technique, nor the "striping incident" in the cell, was in any "interrogator notes" or "interrogation plan."

(U) More than likely, SOLDIER-19 knew what SSG Frederick was going to do. Given that the order for isolation appeared to be a spontaneous reaction to the detainee's recalcitrance and not part of an orchestrated Interrogation Plan; that the "isolation" lasted only approximately half an hour; that SOLDIER-19 chose to re-contact the detainee without an interpreter present; and that SOLDIER-19 was present with SSG Frederick at another incident of detainee abuse; it is possible that SOLDIER-19 had a prearranged agreement with SSG Frederick to "soften up" uncooperative detainees and directed SSG Frederick to strip the detainee in isolation as punishment for being uncooperative, thus providing the detainee an incentive to cooperate during the next interrogation. We believe at a minimum, SOLDIER-19 knew or at least suspected this type of treatment would take place even without specific instructions (Reference Annex B, Appendix 1, SOLDIER-11, SOLDIER-19, PAPPAS, SOLDIER-28).

(3) (U) **Incident(s) #44.** On 13 November 2003, SOLDIER-29 and SOLDIER-10, MI interrogators, noted that a detainee was unhappy with his stay in isolation and visits to the hole.

(U) On 11, 13, and 14 November 2003, MI interrogators SOLDIER-04, SOLDIER-09, SOLDIER-02, and SOLDIER-23 noted that a detainee was "walked and put in the Hole," "pulled out of extreme segregation," "did not seem to be bothered to return to the Hole," "Kept in the Hole for a long time unless he started to talk," and "was in good spirits even after three days in the Hole." (Reference Annex I, Appendix 3, Photo of "the Hole").

(U) A 5 November 2003 interrogation report indicates in the recommendations/future approaches paragraph: "Detainee has been recommended for the hole in ISO. Detainee should be treated harshly because friendly treatment has not been productive and because COL Pappas wants fast resolution, or he will turn the detainee over to someone other than the 205th [MI]."

(U) On 12 November 2003, MI interrogators SOLDIER-18 and SOLDIER-13 noted that a detainee "feared the isolation Hole, and it made him upset, but not enough to break."

(U) On 29 November 2003, MI interrogators SOLDIER-18 and SOLDIER-06 told a detainee that "he would go into the Hole if he didn't start cooperating."

SUBJECT: (U) AR 15-6 Investigation of the Abu Ghraib Detention Facility and
205th MI Brigade

(U) On 8 December 2003, unidentified interrogators told a detainee that he was “recommended for movement to ISO and the Hole - he was told his sun [sunlight] would be taken away, so he better enjoy it now.”

(U) These incidents all indicate the routine and repetitive use of total isolation and light deprivation. Documentation of this technique in the interrogation reports implies those employing it thought it was authorized. The manner it was applied is a violation of the Geneva Conventions, CJTF-7 policy, and Army policy (Reference Annex M, Appendix 2, AR 190-8). Isolation was being employed without proper approval and with little oversight, resulting in abuse (Reference Annex I, Appendix 4, DETAINEE-08).

i. (U) Several alleged abuses were investigated and found to be unsubstantiated. Others turned out to be no more than general rumor or fabrication. This investigation established a threshold below which information on alleged or potential abuse was not included in this report. Fragmentary or difficult to understand allegations or information at times defied our ability to investigate further. One such example is contained in a statement from an alleged abuse victim, DETAINEE-13, who claimed he was always treated well at Abu Ghraib but was abused earlier by his captors. He potentially contradicts that claim by stating his head was hit into a wall. The detainee appears confused concerning the times and locations at which he was abused. Several incidents involved numerous victims and/or occurred during a single “event,” such as the Iraqi Police Interrogations on 24 November 2003. One example receiving some visibility was a report by SOLDIER-22 who overheard a conversation in the “chow hall” between SPC Mitchell and his unidentified “friends.” SPC Mitchell was alleged to have said: “MPs were using detainees as practice dummies. They would hit the detainees as practice shots. They would apply strikes to their necks and knock them out. One detainee was so scared; the MPs held his head and told him everything would be alright, and then they would strike him. The detainees would plead for mercy and the MPs thought it was all funny.” SPC Mitchell was interviewed and denied having knowledge of any abuse. He admitted that he and his friends would joke about noises they heard in the Hard Site and say things such as “the MPs are doing their thing.” SPC Mitchell never thought anyone would take him seriously. Several associates of SPC Mitchell were interviewed (SPC Griffin, SOLDIER-12, PVT Heidenreich). All claimed their discussions with SPC Mitchell were just rumor, and they didn’t think anyone would take him seriously or construe he had personal knowledge of abuse. SPC Mitchell’s duties also make it unlikely he would have witnessed any abuse. He arrived at Abu Ghraib as an analyst, working the day shift, in late November 2003. Shortly after his arrival, the 24 November “shooting incident” occurred and the following day, he was moved to Camp Victory for three weeks. Upon his return, he was transferred to guard duty at Camp Wood and Camp Steel and never returned to the Hard Site. This alleged abuse is likely an individual’s boastful exaggeration of a rumor which was rampant throughout Abu Ghraib, nothing more (Reference Annex B, Appendix 1, SOLDIER-12, GRIFFIN, HEIDENREICH, MITCHELL, SOLDIER-22).

SUBJECT: (U) AR 15-6 Investigation of the Abu Ghraib Detention Facility and
205th MI Brigade

Allegations of Abuse Incidents, the Nature of Reported Abuse, and Associated Personnel								
Note: The chart lists all allegations considered. The specific abuse claimed and entities involved are not confirmed in all cases. The category of abuse are underlined. (See paragraph 5e-h, above)								
Date/ Time	Incident	Nature of Alleged Abuse						Comments
		<u>Nudity/ Humiliation</u>	<u>Assault</u>	<u>Sexual Assault</u>	<u>Use of Dogs</u>	<u>The “Hole”</u>	<u>Other</u>	
15 SEP 03/ 2150	Use of Isolation. Incident #42.					<u>MI/MP</u>		MP log entry confirms MI use of isolation and sensory deprivation as an interrogation technique.
16 SEP 03/ 1315- 1445	MI Directs Removal of Clothing. Incident #34.	<u>MI/MP</u>						MPs respond to MI tasking. Detainee apparently stripped upon arrival to Hard Site at MI direction.
19-20 SEP 03	Naked Detainee During Interrogation. Incident #35.	<u>MI/MP</u>						
20 SEP 03	Two MI Soldiers Beat and Kicked a Cuffed Detainee. Incident #1.		<u>MI</u>					CID investigated and referred the case back to the command.

SUBJECT: (U) AR 15-6 Investigation of the Abu Ghraib Detention Facility and
205th MI Brigade

Allegations of Abuse Incidents, the Nature of Reported Abuse, and Associated Personnel								
Note: The chart lists all allegations considered. The specific abuse claimed and entities involved are not confirmed in all cases. The category of abuse are underlined. (See paragraph 5e-h, above)								
Date/ Time	Incident	Nature of Alleged Abuse						Comments
		<u>Nudity/ Humiliation</u>	<u>Assault</u>	<u>Sexual Assault</u>	<u>Use of Dogs</u>	<u>The “Hole”</u>	<u>Other</u>	
7 OCT 03	Unauthorized Interrogation and Alleged Assault of a Female Detainee. Incident #2.	<u>MI</u>		<u>MI</u>				Unauthorized interrogation. MI personnel received Field Grade Article 15s.
Early OCT 03	Interrogator Directs Partial Removal of Clothing/Failure to Report. Incident #36.	<u>MI</u>						
Early OCT 03	Interrogator Directs Unauthorized Solitary Confinement/Military Police Stripping of Detainee/Failure to Report. Incident #43.	<u>MP</u>	<u>MP</u>			<u>MI/MP</u>		MI directed the MP place the detainee in solitary confinement (apparently the “Hole”) for a few hours. The MPs carried out the request, stripped and hooded the detainee.

SUBJECT: (U) AR 15-6 Investigation of the Abu Ghraib Detention Facility and
205th MI Brigade

Allegations of Abuse Incidents, the Nature of Reported Abuse, and Associated Personnel								
Note: The chart lists all allegations considered. The specific abuse claimed and entities involved are not confirmed in all cases. The category of abuse are underlined. (See paragraph 5e-h, above)								
Date/ Time	Incident	Nature of Alleged Abuse						Comments
		Nudity/ Humiliation	Assault	Sexual Assault	Use of Dogs	The “Hole”	Other	
17 OCT 03 - 19 Oct 03	Photos Depicting a Naked Hooded Detainee Cuffed to His Cell Door. Detainee Cuffed to His Bed with Underwear on his Head. Incident #37.	<u>UNK</u>						Nudity, hooding, and restraint. No indication of association with MI.
20 OCT 03	Detainee Was Stripped and Abused for Making a Shank from a Toothbrush. Incident #8.	<u>MP</u>	<u>MP</u>	<u>MP</u>				No indication of association with MI.
25 OCT 03/ 2015 (est)	Photos of a Naked Detainee on a Dog Leash. Incident #9.	<u>MP</u>		<u>MP</u>				Humiliation and degradation. No indication of association with MI.

SUBJECT: (U) AR 15-6 Investigation of the Abu Ghraib Detention Facility and
205th MI Brigade

Allegations of Abuse Incidents, the Nature of Reported Abuse, and Associated Personnel								
Note: The chart lists all allegations considered. The specific abuse claimed and entities involved are not confirmed in all cases. The category of abuse are underlined. (See paragraph 5e-h, above)								
Date/ Time	Incident	Nature of Alleged Abuse						Comments
		Nudity/ Humiliation	Assault	Sexual Assault	Use of Dogs	The “Hole”	Other	
25 OCT 03/ 2300 – 2317 (est)	Three Naked Detainees Handcuffed Together and Forced to Simulate Sex While Photographed and Abused. Incident #3.	<u>MI/MP</u>	<u>MI/MP</u>	<u>MI/MP</u>				Incident not associated with interrogation operations. MI personnel observed and participated as individuals.
28 OCT 03	Photographs of Female Detainees. Incident #38.	<u>MP</u>		<u>MP</u>				MPs took many photos of two female detainees. One detainee photographed exposing her breasts.
OCT 03	Abuse and Sodomy of a Detainee (Chem Light Incident). Incident #5.	<u>MP</u>	<u>MP</u>	<u>MP</u>				Detainee on MI Hold. No other indication of association with MI.

SUBJECT: (U) AR 15-6 Investigation of the Abu Ghraib Detention Facility and
205th MI Brigade

Allegations of Abuse Incidents, the Nature of Reported Abuse, and Associated Personnel								
Note: The chart lists all allegations considered. The specific abuse claimed and entities involved are not confirmed in all cases. The category of abuse are underlined. (See paragraph 5e-h, above)								
Date/ Time	Incident	Nature of Alleged Abuse						Comments
		Nudity/ Humiliation	Assault	Sexual Assault	Use of Dogs	The “Hole”	Other	
OCT 03	Detainee’s Chin Lacerated. Incident #21.		<u>MP</u>					No indication of association with MI. Assailant unknown.
4 NOV 03/ 2140 - 2315	Detainee Forced to Stand on a Box With Simulated Electrical Wires Attached to his Fingers and Penis. Incident #10.	<u>MP</u>		<u>MP</u>				No indication of association with MI. Attached wire to penis. Threatened detainee with electrocution
4 NOV 03	CIA Detainee Dies in Custody. Incident #7.		<u>CIA</u>					SEAL Team involved in apprehending detainee. <u>MPs</u> photographed body. Tampered with evidence
5 NOV 03	Detainee Forced to Stand on Boxes, Water is Poured on Him, His Genitals are Hit. Incident #20.	<u>MP</u>	<u>MP</u>	<u>MP</u>				Detainee on MI Hold. No other indication of association with MI.

SUBJECT: (U) AR 15-6 Investigation of the Abu Ghraib Detention Facility and
205th MI Brigade

Allegations of Abuse Incidents, the Nature of Reported Abuse, and Associated Personnel								
Note: The chart lists all allegations considered. The specific abuse claimed and entities involved are not confirmed in all cases. The category of abuse are underlined. (See paragraph 5e-h, above)								
Date/ Time	Incident	Nature of Alleged Abuse						Comments
		<u>Nudity/ Humiliation</u>	<u>Assault</u>	<u>Sexual Assault</u>	<u>Use of Dogs</u>	<u>The "Hole"</u>	<u>Other</u>	
7-8 NOV 03/ 2315 – 0024 (est)	Naked "Dog pile and Forced Masturbation of Detainees Following the 6 NOV 03 Riot at Camp Vigilant. Incident #11.	MP	<u>MP</u>	<u>MP</u>				
13 NOV 03	Detainee Claim of MP Abuse Corresponds with Interrogations. Incident #4.	MP	<u>MP</u>					Interrogation reports suggest MI directed abuse. Withholding of bedding
14 NOV 03	MP Log-Detainees Were Ordered "PT'd" By MI. Incident #6.	MP	<u>MP</u>					MPs performed unauthorized medical procedures – stitching detainee wounds

SUBJECT: (U) AR 15-6 Investigation of the Abu Ghraib Detention Facility and
205th MI Brigade

Allegations of Abuse Incidents, the Nature of Reported Abuse, and Associated Personnel								
Note: The chart lists all allegations considered. The specific abuse claimed and entities involved are not confirmed in all cases. The category of abuse are underlined. (See paragraph 5e-h, above)								
Date/ Time	Incident	Nature of Alleged Abuse						Comments
		<u>Nudity/ Humiliation</u>	<u>Assault</u>	<u>Sexual Assault</u>	<u>Use of Dogs</u>	<u>The “Hole”</u>	<u>Other</u>	
16 NOV 03	Stripping of Detainee During Interrogation. Incident #39.	<u>MI</u>						MI interrogator counseled and removed as lead interrogator.
18 NOV 03	Photo Depicting Detainee on the Floor with a Banana Inserted into his Anus. Incident #14.			<u>MP</u>				Detainee had an apparent mental disorder. Photos were taken of him on other dates included showing him naked, praying upside down or covered in feces; blood on a door from an apparently self-inflicted wound; and efforts to restrain him. Appropriate psychiatric care and facilities apparently were not available.
24 NOV 03	MP CPT Beat and Kicked a Detainee. Incident #23.			<u>MP</u>				Subsequent investigation determined to be a staged event and not an abusive incident.

SUBJECT: (U) AR 15-6 Investigation of the Abu Ghraib Detention Facility and
205th MI Brigade

Allegations of Abuse Incidents, the Nature of Reported Abuse, and Associated Personnel								
Note: The chart lists all allegations considered. The specific abuse claimed and entities involved are not confirmed in all cases. The category of abuse are underlined. (See paragraph 5e-h, above)								
Date/ Time	Incident	Nature of Alleged Abuse						Comments
		<u>Nudity/ Humiliation</u>	<u>Assault</u>	<u>Sexual Assault</u>	<u>Use of Dogs</u>	<u>The “Hole”</u>	<u>Other</u>	
24 NOV 03	Interrogator Threatens Use of Military Working Dog. Incident #25.				<u>MP/MI</u>			
24 NOV 03	The use of dogs and humiliation (clothing removal) was approved by MI. Incident #40.	<u>MI/MP</u>			<u>MI/MP</u>			COL Pappas authorized, and LTC Jordan supervised, the harsh treatment of Iraqi Police during interrogations, to include humiliation (clothing removal) and the use of dogs.
26 or 27 Nov 03	MI/MP Abuse During an Interrogation of Iraqi Policeman. Incident #15.		<u>MI/MP</u>					MP cutoff air supply by covering nose and mouth of detainee and twisted his arm at direction of contract interrogator during interrogation of Iraqi policeman.
29 NOV 04	Photo Depicting a detainee in his underwear standing on a box. Incident #13.	UNK	<u>UNK</u>					Photo could not be tied to any specific incident, detainee, or allegation and MI involvement is indeterminate.

SUBJECT: (U) AR 15-6 Investigation of the Abu Ghraib Detention Facility and
205th MI Brigade

Allegations of Abuse Incidents, the Nature of Reported Abuse, and Associated Personnel								
Note: The chart lists all allegations considered. The specific abuse claimed and entities involved are not confirmed in all cases. The category of abuse are underlined. (See paragraph 5e-h, above)								
Date/ Time	Incident	Nature of Alleged Abuse						Comments
		<u>Nudity/ Humiliation</u>	<u>Assault</u>	<u>Sexual Assault</u>	<u>Use of Dogs</u>	<u>The “Hole”</u>	<u>Other</u>	
30 NOV 03	MP Log Entry- Detainee Was Found in Cell Covered in Blood. Incident #17.		<u>UNK</u>					Wounds apparently self-inflicted. No indication of association with MI.
Circa Dec 03	Photo Depicting detainee in stress position on chair. Incident #24.		<u>MI</u>					Photo shows detainee kneeling on a chair with Interrogators watching. No associated interrogation summaries to ID detainee
4 DEC 03	MP Log- Determination of Inmate Clothing by MI. Incident #41.	<u>MI/MP</u>						Suggests MI direction to remove selected detainee’s clothing, with MP collaboration.

SUBJECT: (U) AR 15-6 Investigation of the Abu Ghraib Detention Facility and
205th MI Brigade

Allegations of Abuse Incidents, the Nature of Reported Abuse, and Associated Personnel								
Note: The chart lists all allegations considered. The specific abuse claimed and entities involved are not confirmed in all cases. The category of abuse are underlined. (See paragraph 5e-h, above)								
Date/ Time	Incident	Nature of Alleged Abuse						Comments
		Nudity/ Humiliation	Assault	Sexual Assault	Use of Dogs	The “Hole”	Other	
12-13 DEC 03 (est)	Detainee Involved in Attempted Murder of MPs Claims Retaliatory Acts Upon Return to the Hard Site. Incident #18.		<u>MP</u>		<u>MP</u>			Detainee allegations may have been exaggerated. MP – Forced him to eat pork and forced alcohol in his mouth. MPs may have retaliated in response to the detainee shooting an MP on 24 NOV 03.
4-13 DEC 03 (est)	Withholding of Clothing, Bedding, and Medical Care. Incident #19.	<u>MP</u>	<u>UNK</u>					MI Soldier discovered and attempted to rectify the situation. A U/I COL or LTC medical officer refused to remove a catheter when notified by MI.
12 DEC 03	Dog Bites Iranian Detainee. Incident #27.	<u>MP</u>	<u>MP</u>		<u>MP</u>			Detainee on MI Hold. No other indication of association with MI.
14/15 DEC 03	MI Uses Dog in Interrogation. Incident #29.				<u>MI/MP</u>			Used allegedly in response to COL Pappas’s blanket approval for use of harsher techniques against Saddam associates.

SUBJECT: (U) AR 15-6 Investigation of the Abu Ghraib Detention Facility and
205th MI Brigade

Allegations of Abuse Incidents, the Nature of Reported Abuse, and Associated Personnel								
Note: The chart lists all allegations considered. The specific abuse claimed and entities involved are not confirmed in all cases. The category of abuse are underlined. (See paragraph 5e-h, above)								
Date/ Time	Incident	Nature of Alleged Abuse						Comments
		<u>Nudity/ Humiliation</u>	<u>Assault</u>	<u>Sexual Assault</u>	<u>Use of Dogs</u>	<u>The “Hole”</u>	<u>Other</u>	
14/15 DEC 03	MI Uses Dog in Interrogation. Incident #31.				<u>MI/MP</u>			Interrogation report indicates dogs used with little effect during an interrogation.
Late DEC 03	Contract Interrogator Possibly Involved in Dog Use on Detainee. Incident #32.				<u>MI/MP</u>			
18 DEC 03 or later	Dog Handler Uses Dog on Detainee. Incident #28.				<u>MP</u>			Photos of incident show only MP personnel; however, it is possible MI directed the dogs to prepare the detainee for interrogation.
27 DEC 03 (est)	Photo Depicting Apparent Shotgun Wounds on Detainee’s Buttocks. Incident #12.	<u>UNK</u>	<u>UNK</u>					Detainee apparently shot by MP personnel with shotgun using less-than-lethal rounds. Nudity may have been required to have medics observe and treat wounds. No indication of association with MI.

SUBJECT: (U) AR 15-6 Investigation of the Abu Ghraib Detention Facility and
205th MI Brigade

Allegations of Abuse Incidents, the Nature of Reported Abuse, and Associated Personnel								
Note: The chart lists all allegations considered. The specific abuse claimed and entities involved are not confirmed in all cases. The category of abuse are underlined. (See paragraph 5e-h, above)								
Date/ Time	Incident	Nature of Alleged Abuse						Comments
		Nudity/ Humiliation	Assault	Sexual Assault	Use of Dogs	The "Hole"	Other	
8 JAN 04 (Estimated)	Dog Used to Scare Juvenile Inmates. Incident #26.				<u>MP</u>			MI Soldier observed the event while in the area during an interrogation. MP motivation unknown. MI Soldier failed to report it.
Unspecified	Un-muzzled dog used during an interrogation. Incident #30.				<u>MI/MP</u>			MI approved the use of dogs during an interrogation. The dog was un-muzzled without such approval.
Unspecified	Possible Rape of a Detainee by a US Translator. Incident #22.			<u>MI</u>				

SUBJECT: (U) AR 15-6 Investigation of the Abu Ghraib Detention Facility and
205th MI Brigade

Allegations of Abuse Incidents, the Nature of Reported Abuse, and Associated Personnel								
Note: The chart lists all allegations considered. The specific abuse claimed and entities involved are not confirmed in all cases. The category of abuse are underlined. (See paragraph 5e-h, above)								
Date/ Time	Incident	Nature of Alleged Abuse						Comments
		<u>Nudity/ Humiliation</u>	<u>Assault</u>	<u>Sexual Assault</u>	<u>Use of Dogs</u>	<u>The “Hole”</u>	<u>Other</u>	
Unspeci- fied	Civilian Interrogator Forcibly Pulls Detainee from Truck and Drags Him Across Ground. Incident #16.		<u>MI</u>					The incident was reported by MI, but CID apparently did not pursue the case.
Various Dates	MI Use of Isolation as an Interrogation Technique. Incident #44.					<u>MI/MP</u>		Seven detainees are associated with this line item.
Various Dates	MI Forces Detainee to Wear Women’s Underwear on his Head. Incident #33.	<u>MI/MP</u>						MPs may have performed two of the incidents identified in photos, and may have no MI association.

SUBJECT: (U) AR 15-6 Investigation of the Abu Ghraib Detention Facility and
205th MI Brigade

6. (U) Findings and Recommendations.

a. (U) **Major Finding:** From 25 July 2003 to 6 February 2004, twenty-seven (27) 205 MI BDE personnel allegedly:

- Requested, encouraged, condoned, or solicited MP personnel to abuse detainees or;
- Participated in detainee abuse or;
- Violated established interrogation procedures and applicable laws and regulations as preparation for interrogation operations at Abu Ghraib.

(U) **Explanation:** Some MI personnel encouraged, condoned, participated in, or ignored abuse. In a few instances, MI personnel acted alone in abusing detainees. MI abuse and MI solicitation of MP abuse included the use of isolation with sensory deprivation (“the Hole”), removal of clothing and humiliation, the use of dogs to “fear up” detainees, and on one occasion, the condoned twisting of a detainee’s cuffed wrists and the smothering of this detainee with a cupped hand in MI’s presence. Some MI personnel violated established interrogation practices, regulations, and conventions which resulted in the abuse of detainees. While Interrogation and Counter-Resistance Policies (ICRP) were poorly defined and changed several times, in most cases of detainee abuse the MI personnel involved knew or should have known what they were doing was outside the bounds of their authority. Ineffective leadership at the JIDC failed to detect violations and discipline those responsible. Likewise, leaders failed to provide adequate training to ensure Soldiers understood the rules and complied.

(U) **Recommendation:** The Army needs to re-emphasize Soldier and leader responsibilities in interrogation and detention operations and retrain them to perform in accordance with law, regulations, and Army values and to live up to the responsibilities of their rank and position. Leaders must also provide adequate training to ensure Soldiers understand their authorities. The Army must ensure that future interrogation policies are simple, direct and include safeguards against abuse. Organizations such as the JIDC must possess a functioning chain of command capable of directing interrogation operations.

b. (U) Other Findings and Recommendations.

(1) (U) **Finding:** There was a lack of clear Command and Control of Detainee Operations at the CJTF-7 level.

(U) **Explanation:** COL Pappas was rated by MG Wojdakowski, DCG, V Corps/CJTF-7. MG Wojdakowski, however, was not directly involved with interrogation operations. Most of COL Pappas' direction was coming from LTG Sanchez directly as well as from MG Fast, the C2.

SUBJECT: (U) AR 15-6 Investigation of the Abu Ghraib Detention Facility and
205th MI Brigade

BG Karpinski was rated by BG Diamond, Commander, 377th Theater Support Command (377 TSC). However, she testified that she believed her rater was MG Wojdakowski and in fact it was he she received her direction from the entire time she was in Iraq (Reference Annex B, Appendix 1, KARPINSKI). The 800 MP BDE was TACON to CJTF-7. Overall responsibility for detainee operations never came together under one person short of LTG Sanchez himself until the assignment of MG G. Miller in April 2004.

(U) **Recommendation:** There should be a single authority designated for command and control for detention and interrogation operations. (DoD/DA)

(2) (U) **Finding:** FRAGO 1108 appointing COL Pappas as FOB Commander at Abu Ghraib was unclear. This issue did not impact detainee abuse.

(U) **Explanation:** Although FRAGO 1108 appointing COL Pappas as FOB Commander on 19 November 2003 changed the command relationship, it had no specific effect on detainee abuses at Abu Ghraib. The FRAGO giving him TACON of the 320 MP BN did not contain any specified or implied tasks. The TACON did not include responsibility for conducting prison or "Warden" functions. Those functions remained the responsibility of the 320 MP BN. This FRAGO has been cited as a significant contributing factor that allowed the abuses to happen, but the abuses were already underway for two months before CJTF-7 issued this FRAGO. COL Pappas and the Commander of the 320 MP BN interpreted that FRAGO strictly for COL Pappas to exercise the external Force Protection and Security of Detainees. COL Pappas had a Long Range Reconnaissance Company in the 165 MI BN that would augment the external protection of Abu Ghraib. The internal protection of detainees, however, still remained the responsibility of the 320 MP BN. The confusion and disorganization between MI and MPs already existed by the time CJTF-7 published the FRAGO. Had there been no change of FOB Command, it is likely abuse would have continued anyway.

(U) **Recommendation:** Joint Task Forces such as CJTF-7 should clearly specify relationships in FRAGOs so as to preclude confusion. Terms such as Tactical Control (TACON) should be clearly defined to identify specific command relationships and preclude confusion. (DoD/CJTF-7)

(3) (U) **Finding:** The JIDC was manned with personnel from numerous organizations and consequently lacked unit cohesion. There was an absence of an established, effective MI chain of command at the JIDC.

(U) **Explanation:** A decision was made not to run the JIDC as a unit mission. The JIDC was manned, led and managed by staff officers from multiple organizations as opposed to a unit with its functioning chain of command. Responsibilities for balancing the demands of

SUBJECT: (U) AR 15-6 Investigation of the Abu Ghraib Detention Facility and
205th MI Brigade

managing interrogation operations and establishing good order and discipline in this environment were unclear and lead to lapses in accountability.

(U) **Recommendation:** JIDCs need to be structured, manned, trained and equipped as standard military organizations. These organizations should be certified by TRADOC and/or JFCOM. Appropriate Army and Joint doctrine should be developed defining JIDCs' missions and functions as separate commands. (DoD/DA/CJTF-7)

(4) (U) **Finding:** Selecting Abu Ghraib as a detention facility placed soldiers and detainees at an unnecessary force protection risk.

(U) **Explanation:** Failure adequately to protect and house detainees is a violation of the Third and Fourth Geneva Conventions and AR 190-8. Therefore, the selection of Abu Ghraib as a detention facility was inappropriate because of its inherent indefensibility and poor condition. The selection of Abu Ghraib as a detention center was dictated by the Coalition Provisional Authority officials despite concerns that the Iraqi people would look negatively on Americans interning detainees in a facility associated with torture. Abu Ghraib was in poor physical condition with buildings and sections of the perimeter wall having been destroyed, resulting in completely inadequate living conditions. Force protection must be a major consideration in selecting any facility as a detention facility. Abu Ghraib was located in the middle of the Sunni Triangle, an area known to be very hostile to coalition forces. Further, being surrounded by civilian housing and open fields and encircled by a network of roads and highways, its defense presented formidable force protection challenges. Even though the force protection posture at Abu Ghraib was compromised from the start due to its location and poor condition, coalition personnel still had a duty and responsibility to undertake appropriate defensive measures. However, the poor security posture at Abu Ghraib resulted in the deaths and wounding of both coalition forces and detainees.

(U) **Recommendations:**

- Detention centers must be established in accordance with AR 190-8 to ensure safety and compliance with the Geneva Conventions. (DoD/DA/CJTF-7).
- As a matter of policy, force protection concerns must be applicable to any detention facility and all detention operations. (DoD/DA/CJTF-7)
- Protect detainees in accordance with Geneva Convention IV by providing adequate force protection. (DoD/DA/CJTF-7)

(5) (U) **Finding:** Leaders failed to take steps to effectively manage pressure placed upon JIDC personnel.

(U) **Explanation:** During our interviews, leaders within the MI community commented upon the intense pressure they felt from higher headquarters, to include CENTCOM,

SUBJECT: (U) AR 15-6 Investigation of the Abu Ghraib Detention Facility and
205th MI Brigade

the Pentagon, and DIA for timelier, actionable intelligence (Reference Annex B, Appendix 1, WOOD, PAPPAS, and PRICE). These leaders have stated that this pressure adversely affected their decision making. Requests for information were being sent to Abu Ghraib from a number of headquarters without any prioritization. Based on the statements from the interrogators and analysts, the pressure was allowed to be passed down to the lowest levels.

(U) **Recommendation:** Leaders must balance mission requirements with unit capabilities, soldier morale and effectiveness. Protecting Soldiers from unnecessary pressure to enhance mission effectiveness is a leader's job. Rigorous and challenging training can help prepare units and soldiers for the stress they face in combat. (DoD/DA/CENTCOM/CJTF-7)

(6) (U) **Finding:** Some capturing units failed to follow procedures, training, and directives in the capture, screening, and exploitation of detainees.

(U) **Explanation:** The role of the capturing unit was to conduct preliminary screening of captured detainees to determine if they posed a security risk or possessed information of intelligence value. Detainees who did not pose a security risk and possessed no intelligence value should have been released. Those that posed a security risk and possessed no intelligence value should have been transferred to Abu Ghraib as a security hold. Those that possessed intelligence information should have been interrogated within 72 hours at the tactical level to gather perishable information of value to the capturing unit. After 72 hours, these personnel should have been transferred to Abu Ghraib for further intelligence exploitation as an MI hold. Since most detainees were not properly screened, large numbers of detainees were transferred to Abu Ghraib, who in some cases should not have been sent there at all, and in almost all cases, were not properly identified or documented in accordance with doctrine and directives. This failure led to the arrival of a significant number of detainees at Abu Ghraib. Without proper detainee capture documentation, JIDC interrogators were diverted from interrogation and intelligence production to screening operations in order to assess the value of the incoming detainees (no value, security hold, or MI Hold). The overall result was that less intelligence was produced at the JIDC than could have been if capturing forces had followed proper procedures.

(U) **Recommendation:** Screening, interrogation and release procedures at the tactical level need to be properly executed. Those detainees who pose no threat and are of no intelligence value should be released by capturing units within 72 hours. Those detainees thought to be a threat but of no further intelligence value should be sent to a long term confinement facility. Those detainees thought to possess further intelligence value should be sent to a Corps/Theater Interrogation Center. (DA/CENTCOM/CJTF-7)

(7) (U) **Finding:** DoD's development of multiple policies on interrogation operations for use in different theaters or operations confused Army and civilian Interrogators at Abu Ghraib.

SUBJECT: (U) AR 15-6 Investigation of the Abu Ghraib Detention Facility and
205th MI Brigade

(U) **Explanation:** National policy and DoD directives were not completely consistent with Army doctrine concerning detainee treatment or interrogation tactics, resulting in CJTF-7 interrogation and counter-resistance policies and practices that lacked basis in Army interrogation doctrine. As a result, interrogators at Abu Ghraib employed non-doctrinal approaches that conflicted with other DoD and Army regulatory, doctrinal and procedural guidance.

(U) **Recommendation:** Adopt one DoD policy for interrogation, within the framework of existing doctrine, adhering to the standards found in doctrine, and enforce that standard policy across DoD. Interrogation policy must be simple and direct, with reference to existing doctrine, and possess effective safeguards against abuse. It must be totally understandable by the interrogator using it. (DoD/DA/CJTF-7)

(8) (U) **Finding:** There are an inadequate number of MI units to satisfy current and future HUMINT missions. The Army does not possess enough interrogators and linguists to support interrogation operations.

(U) **Explanation:** The demand for interrogators and linguists to support tactical screening operations at the point-of-capture of detainees, tactical HUMINT teams, and personnel to support interrogation operations at organizations like the JIDC cannot be supported with the current force structure. As a result, each of these operations in Iraq was undermanned and suffered accordingly.

(U) **Recommendation:** The Army must increase the number of HUMINT units to overcome downsizing of HUMINT forces over the last 10 years and to address current and future HUMINT requirements.

(9) (U) **Finding:** The JIDC was not provided with adequate personnel resources to effectively operate as an interrogation center.

(U) **Explanation:** The JIDC was established in an ad hoc manner without proper planning, personnel, and logistical support for the missions it was intended to perform. Interrogation and analyst personnel were quickly kluged together from a half dozen units in an effort to meet personnel requirements. Even at its peak strength, interrogation and analyst manpower at the JIDC was too shorthanded to deal with the large number of detainees at hand. Logistical support was also inadequate.

(U) **Recommendation:** The Army and DoD should plan on operating JIDC organizations in future operational environments, establish appropriate manning and equipment authorizations for the same. (DoD/DA)

SUBJECT: (U) AR 15-6 Investigation of the Abu Ghraib Detention Facility and
205th MI Brigade

(10) (U) **Finding:** There was/is a severe shortage of CAT II and CAT III Arab linguists available in Iraq.

(U) **Explanation:** This shortage negatively affected every level of detainee operations from point-of-capture through detention facility. Tactical units were unable to properly screen detainees at their levels not only because of the lack of interrogators but even more so because of the lack of interpreters. The linguist problem also existed at Abu Ghraib. There were only 20 linguists assigned to Abu Ghraib at the height of operations. Linguists were a critical node and limited the maximum number of interrogations that could be conducted at any time to the number of linguists available.

(U) **Recommendation:** Army and DoD need to address the issue of inadequate linguist resources to conduct detention operations. (DA/DoD)

(11) (U) **Finding:** The cross leveling of a large number of Reserve Component (RC) Soldiers during the Mobilization process contributed to training challenges and lack of unit cohesion of the RC units at Abu Ghraib.

(U) **Recommendation:** If cross leveling of personnel is necessary in order to bring RC units up to required strength levels, then post mobilization training time should be extended. Post mobilization training should include unit level training in addition to Soldier training to ensure cross leveled Soldiers are made part of the team. (DA)

(12) (U) **Finding:** Interrogator training in the Laws of Land Warfare and the Geneva Conventions is ineffective.

(U) **Explanation:** The US Army Intelligence Center and follow on unit training provided interrogators with what appears to be adequate curriculum, practical exercises and man-hours in Law of Land Warfare and Geneva Conventions training. Soldiers at Abu Ghraib, however, remained uncertain about what interrogation procedures were authorized and what proper reporting procedures were required. This indicates that Initial Entry Training for interrogators was not sufficient or was not reinforced properly by additional unit training or leadership.

(U) **Recommendation:** More training emphasis needs to be placed on Soldier and leader responsibilities concerning the identification and reporting of detainee abuse incidents or concerns up through the chain of command, or to other offices such as CID, IG or SJA. This training should not just address the rules, but address case studies from recent and past detainee and interrogation operations to address likely issues interrogators and their supervisors will encounter. Soldiers and leaders need to be taught to integrate Army values and ethical decision-

SUBJECT: (U) AR 15-6 Investigation of the Abu Ghraib Detention Facility and
205th MI Brigade

making to deal with interrogation issues that are not clearly prohibited or allowed. Furthermore, it should be stressed that methods employed by US Army interrogators will represent US values.

(13) (U) **Finding:** MI, MP, and Medical Corps personnel observed and failed to report instances of Abuse at Abu Ghraib. Likewise, several reports indicated that capturing units did not always treat detainees IAW the Geneva Convention.

(U) **Recommendation:** DoD should improve training provided to all personnel in Geneva Conventions, detainee operations, and the responsibilities of reporting detainee abuse. (DoD)

(14) (U) **Finding:** Combined MI/MP training in the conduct of detainee/interrogation operations is inadequate.

(U) **Explanation:** MI and MP personnel at Abu Ghraib had little knowledge of each other's missions, roles and responsibilities in the conduct of detainee/interrogation operations. As a result, some "lanes in the road" were worked out "on the fly." Other relationships were never fully defined and contributed to the confused operational environment.

(U) **Recommendation:** TRADOC should initiate an effort to develop a cross branch training program in detainee and interrogation operations training. FORSCOM should reinstitute combined MI/MP unit training such as the Gold Sword/Silver Sword Exercises that were conducted annually. (DA)

(15) (U) **Finding:** MI leaders do not receive adequate training in the conduct and management of interrogation operations.

(U) **Explanation:** MI Leaders at the JIDC were unfamiliar with and untrained in interrogation operations (with the exception of CPT Wood) as well as the mission and purposes of a JIDC. Absent any knowledge from training and experience in interrogation operations, JIDC leaders had to rely upon instinct to operate the JIDC. MTTs and Tiger Teams were deployed to the JIDC as a solution to help train interrogators and leaders in the management of HUMINT and detainee/interrogator operations.

(U) **Recommendation:** MI Officer, NCO and Warrant Officer training needs to include interrogation operations to include management procedures, automation support, collection management and JIDC operations. Officer and senior NCO training should also emphasize the potential for abuse involved in detention and interrogation operations. (DA)

SUBJECT: (U) AR 15-6 Investigation of the Abu Ghraib Detention Facility and
205th MI Brigade

(16) (U) **Finding:** Army doctrine exists for both MI interrogation and MP detainee operations, but it was not comprehensive enough to cover the situation that existed at Abu Ghraib.

(U) **Explanation:** The lines of authority and accountability between MI and MP were unclear and undefined. For example, when MI would order sleep adjustment, MPs would use their judgment on how to apply that technique. The result was MP taking detainees from their cells stripping them and giving them cold showers or throwing cold water on them to keep them awake.

(U) **Recommendation:** DA should conduct a review to determine future Army doctrine for interrogation operations and detention operations. (DA)

(17) (U) **Finding:** Because of a lack of doctrine concerning detainee and interrogation operations, critical records on detainees were not created or maintained properly thereby hampering effective operations.

(U) **Explanation:** This lack of record keeping included the complete life cycle of detainee records to include detainee capture information and documentation, prison records, medical records, interrogation plans and records, and release board records. Lack of record keeping significantly hampered the ability of this investigation to discover critical information concerning detainee abuse.

(U) **Recommendation:** As TRADOC reviews and enhances detainee and interrogation operations doctrine, it should ensure that record keeping and information sharing requirements are addressed. (DA)

(18) (U) **Finding:** Four (4) contract interrogators allegedly abused detainees at Abu Ghraib.

(U) **Explanation:** The contracting system failed to ensure that properly trained and vetted linguist and interrogator personnel were hired to support operations at Abu Ghraib. The system also failed to provide useful contract management functions in support of the facility. Soldiers and leaders at the prison were unprepared for the arrival, employment, and oversight of contract interrogators.

(U) **Recommendations:** The Army should review the use contract interrogators. In the event contract interrogators must be used, the Army must ensure that they are properly qualified from a training and performance perspective, and properly vetted. The Army should establish standards for contract requirements and personnel. Additionally, the Army must

SUBJECT: (U) AR 15-6 Investigation of the Abu Ghraib Detention Facility and
205th MI Brigade

provide sufficient contract management resources to monitor contracts and contractor performance at the point of performance.

(19) (U) **Observation:** MG Miller's visit did not introduce "harsh techniques" into the Abu Ghraib interrogation operation.

(U) **Explanation:** While there was an increase in intelligence reports after the visit, it appears more likely it was due to the assignment of trained interrogators and an increased number of MI Hold detainees to interrogate. This increase in production does not equate to an increase in quality of the collected intelligence. MG G. Miller's visit did not introduce "harsh techniques" into the Abu Ghraib interrogation operation.

(20) (U) **Finding:** The JTF-GTMO training team had positive impact on the operational management of the JIDC; however, the JTF-GTMO training team inadvertently validated restricted interrogation techniques.

(U) **Explanation:** The JTF-GTMO team stressed the conduct of operations with a strategic objective, while the Abu Ghraib team remained focused on tactical operations. Instead of providing guidance and assistance, the team's impact was limited to one-on-one interaction during interrogations. Clearly a significant problem was the JTF-GTMO's lack of understanding of the approved interrogation techniques, either for GTMO or CJTF-7 or Abu Ghraib. When the training team composed of the experts from a national level operation failed to recognize, object to, or report detainee abuse, such as the use of nudity as an interrogation tactic, they failed as a training team and further validated the use of unacceptable interrogation techniques.

(U) **Recommendation:** TRADOC should initiate an Army-wide effort to ensure all personnel involved in detention and interrogation operations are properly trained with respect to approved doctrine. There should be a MTT to assist ongoing detention operations. This MTT must be of the highest quality and understand the mission they have been sent to support. They must have clearly defined and unmistakable objectives. Team members with varied experience must be careful to avoid providing any training or guidance that contradicts local or national policy. (DA/DoD)

(21) (U) **Finding:** The Fort Huachuca MTT failed to adapt the ISCT training (which was focused upon improving the JTF-GTMO operational environment) to the mission needs of CJTF-7 and JIDC; however, actions of one team member resulted in the inadvertent validation of restricted interrogation techniques.

(U) **Explanation:** Although the Fort Huachuca Team (ISCT) team was successful in arranging a few classes and providing some formal training, to include classes on the Geneva Conventions, both the JIDC leadership and the ISCT team failed to include/require the contract

SUBJECT: (U) AR 15-6 Investigation of the Abu Ghraib Detention Facility and
205th MI Brigade

personnel to attend the training. Furthermore, the training that was given was ineffective and certainly did nothing to prevent the abuses occurring at Abu Ghraib, e.g., the "Hole," nakedness, withholding of bedding, and the use of dogs to threaten detainees. The ISCT MTT members were assigned to the various Tiger Teams/sections to conduct interrogations. The ISCT team's lack of understanding of approved doctrine was a significant failure. This lack of understanding was evident in SFC Walters' "unofficial" conversation with one of the Abu Ghraib interrogators (CIVILIAN21). SFC Walters related several stories about the use of dogs as an inducement, suggesting the interrogator talk to the MPs about the possibilities. SFC Walters noted that detainees are most susceptible during the first few hours after capture. "The prisoners are captured by Soldiers, taken from their familiar surroundings, blindfolded and put into a truck and brought to this place (Abu Ghraib); and then they are pushed down a hall with guards barking orders and thrown into a cell, naked; and that not knowing what was going to happen or what the guards might do caused them extreme fear." It was also suggested that an interrogator could take some pictures of what seemed to be guards being rough with prisoners so he could use them to scare the prisoners. This conversation certainly contributed to the abusive environment at Abu Ghraib. The team validated the use of unacceptable interrogation techniques. The ISCT team's Geneva Conventions training was not effective in helping to halt abusive techniques, as it failed to train Soldiers on their responsibilities for identifying and reporting those techniques.

(U) **Recommendation:** TRADOC should initiate an Army-wide effort to ensure all personnel involved in detention and interrogation operations are properly trained with respect to approved doctrine. There should be a MTT to assist ongoing detention operations. This MTT must be of the highest quality and understand the mission they have been sent to support. They must have clearly defined and unmistakable objectives. Team members with varied experience must be careful to avoid providing any training or guidance that contradicts local or national policy. (DA/DoD)

(22) (U) **Finding:** Other Government Agency (OGA) interrogation practices led to a loss of accountability at Abu Ghraib.

(U) **Explanation:** While the FBI, JTF-121, Criminal Investigative Task Force, Iraq Survey Group, and the CIA were all present at Abu Ghraib, the acronym "Other Government Agency" referred almost exclusively to the CIA. Lack of military control over OGA interrogator actions or lack of systemic accountability for detainees plagued detainee operations in Abu Ghraib almost from the start. Army allowed CIA to house "Ghost Detainees" who were unidentified and unaccounted for in Abu Ghraib. This procedure created confusion and uncertainty concerning their classification and subsequent DoD reporting requirements under the Geneva Conventions. Additionally, the treatment and interrogation of OGA detainees occurred under different practices and procedures which were absent any DoD visibility, control, or oversight. This separate grouping of OGA detainees added to the confusion over proper treatment of detainees and created a perception that OGA techniques and practices were suitable

SUBJECT: (U) AR 15-6 Investigation of the Abu Ghraib Detention Facility and
205th MI Brigade

and authorized for DoD operations. No memorandum of understanding on detainee accountability or interrogation practices between the CIA and CJTF-7 was created.

(U) **Recommendation:** DoD must enforce adherence by OGA with established DoD practices and procedures while conducting detainee interrogation operations at DoD facilities.

(23) (U) **Finding:** There was neither a defined procedure nor specific responsibility within CJTF-7 for dealing with ICRC visits. ICRC recommendations were ignored by MI, MP and CJTF-7 personnel.

(U) **Explanation:** Within this investigation's timeframe, 16 September 2003 through 31 January 2004, the ICRC visited Abu Ghraib three times, notifying CJTF-7 twice of their visit results, describing serious violations of international Humanitarian Law and of the Geneva Conventions. In spite of the ICRC's role as independent observers, there seemed to be a consensus among personnel at Abu Ghraib that the allegations were not true. Neither the leadership, nor CJTF-7 made any attempt to verify the allegations.

(U) **Recommendation:** DoD should review current policy concerning ICRC visits and establish procedures whereby findings and recommendations made by the ICRC are investigated. Investigation should not be done by the units responsible for the facility in question. Specific procedures and responsibilities should be developed for ICRC visits, reports, and responses. There also needs to be specific inquiries made into ICRC allegations of abuse or maltreatment by an independent entity to ensure that an unbiased review has occurred. (DoD/CJTF-7)

(24) (U) **Finding:** Two soldiers that the 519 MI BN had reason to suspect were involved in the questionable death of a detainee in Afghanistan were allowed to deploy and continue conducting interrogations in Iraq. While in Iraq, those same soldiers were alleged to have abused detainees.

(U) **Recommendation:** Once soldiers in a unit have been identified as possible participants in abuse related to the performance of their duties, they should be suspended from such duties or flagged.

(25) (U) **Observation:** While some MI Soldiers acted outside the scope of applicable laws and regulations, most Soldiers performed their duties in accordance with the Geneva Conventions and Army Regulations.

(U) **Explanation:** MI Soldiers operating the JIDC at Abu Ghraib screened thousands of Iraqi detainees, conducted over 2500 interrogations, and produced several thousand valuable intelligence products supporting the war fighter and the global war on terrorism. This great effort

SUBJECT: (U) AR 15-6 Investigation of the Abu Ghraib Detention Facility and
205th MI Brigade

was executed in difficult and dangerous conditions with inadequate physical and personnel resources.

c. (U) Individual Responsibility for Detainee Abuse at Abu Ghraib.

(1) (U) **Finding:** COL Thomas M. Pappas, Commander, 205 MI BDE. A preponderance of evidence supports that COL Pappas did, or failed to do, the following:

- Failed to insure that the JIDC performed its mission to its full capabilities, within the applicable rules, regulations and appropriate procedures.
- Failed to properly organize the JIDC.
- Failed to put the necessary checks and balances in place to prevent and detect abuses.
- Failed to ensure that his Soldiers and civilians were properly trained for the mission.
- Showed poor judgment by leaving LTC Jordan in charge of the JIDC during the critical early stages of the JIDC.
- Showed poor judgment by leaving LTC Jordan in charge during the aftermath of a shooting incident known as the Iraqi Police Roundup (IP Roundup).
- Improperly authorized the use of dogs during interrogations. Failed to properly supervise the use of dogs to make sure they were muzzled after he improperly permitted their use.
- Failed to take appropriate action regarding the ICRC reports of abuse.
- Failed to take aggressive action against Soldiers who violated the ICRP, the CJTF-7 interrogation and Counter-Resistance Policy and the Geneva Conventions.
- Failed to properly communicate to Higher Headquarters when his Brigade would be unable to accomplish its mission due to lack of manpower and/or resources. Allowed his Soldiers and civilians at the JIDC to be subjected to inordinate pressure from Higher Headquarters.
- Failed to establish appropriate MI and MP coordination at the brigade level which would have alleviated much of the confusion that contributed to the abusive environment at Abu Ghraib.
- The significant number of systemic failures documented in this report does not relieve COL Pappas of his responsibility as the Commander, 205th MI BDE for the abuses that occurred and went undetected for a considerable length of time.

(U) **Recommendation:** This information should be forwarded to COL Pappas' chain of command for appropriate action.

SUBJECT: (U) AR 15-6 Investigation of the Abu Ghraib Detention Facility and
205th MI Brigade

(2) (U) **Finding:** LTC Stephen L. Jordan, Director, Joint Interrogation Debriefing Center. A preponderance of evidence supports that LTC Jordan did, or failed to do, the following:

- Failed to properly train Soldiers and civilians on the ICRP.
- Failed to take full responsibility for his role as the Director, JIDC.
- Failed to establish the necessary checks and balances to prevent and detect abuses.
- Was derelict in his duties by failing to establish order and enforce proper use of ICRP during the night of 24 November 2003 (IP Roundup) which contributed to a chaotic situation in which detainees were abused.
- Failed to prevent the unauthorized use of dogs and the humiliation of detainees who were kept naked for no acceptable purpose while he was the senior officer-in-charge in the Hard Site.
- Failed to accurately and timely relay critical information to COL Pappas, such as:
 - The incident where a detainee had obtained a weapon.
 - ICRC issues.
- Was deceitful during this, as well as the MG Taguba, investigations. His recollection of facts, statements, and incidents were always recounted to avoid blame or responsibility. His version of events frequently diverged from most others.
- Failed to obey a lawful order to refrain from contacting anyone except his attorney regarding this investigation. He conducted an e-mail campaign soliciting support from others involved in the investigation.

(U) **Recommendation:** This information should be forwarded to LTC Jordan's chain of command for appropriate action.

SUBJECT: (U) AR 15-6 Investigation of the Abu Ghraib Detention Facility and
205th MI Brigade

(3) (U) **Finding: MAJ David M. Price, Operations Officer, Joint Interrogation and Debriefing Center, 141st MI Battalion.** A preponderance of evidence indicates that MAJ Price did, or failed to do, the following:

- Failed to properly train Soldiers and civilians on the ICRP.
- Failed to understand the breadth of his responsibilities as the JIDC Operations Officer. Failed to effectively assess, plan, and seek command guidance and assistance regarding JIDC operations.
- Failed to intervene when the Interrogation Control Element (ICE) received pressure from Higher Headquarters.
- Failed to plan and implement the necessary checks and balances to prevent and detect abuses.
- Failed to properly review interrogation plans which clearly specified the improper use of nudity and isolation as punishment.

(U) **Recommendation:** This information should be forwarded to MAJ Price's chain of command for appropriate action.

(4) (U) **Finding: MAJ Michael D. Thompson, Deputy Operations Officer, Joint Interrogation and Debriefing Center, 325 MI BN.** A preponderance of evidence supports that MAJ Thompson failed to do the following:

- Failed to properly train Soldiers and civilians on the ICRP.
- Failed to understand the breadth of his responsibilities as the JIDC Deputy Operations Officer. Failed to effectively assess, plan, and seek command guidance and assistance regarding JIDC operations.
- Failed to intervene when the ICE received pressure from Higher Headquarters.
- Failed to plan and implement the necessary checks and balances to prevent and detect abuses.
- Failed to properly review interrogation plans which clearly specified the improper use of nudity and isolation as punishment.

(U) **Recommendation:** This information should be forwarded to MAJ Thompson's chain of command for appropriate action.

SUBJECT: (U) AR 15-6 Investigation of the Abu Ghraib Detention Facility and
205th MI Brigade

(5) (U) **Finding:** CPT Carolyn A. Wood, Officer in Charge, Interrogation Control Element (ICE), Joint Interrogation and Debriefing Center, 519 MI BDE. A preponderance of evidence supports that CPT Wood failed to do the following:

- Failed to implement the necessary checks and balances to detect and prevent detainee abuse. Given her knowledge of prior abuse in Afghanistan, as well as the reported sexual assault of a female detainee by three 519 MI BN Soldiers working in the ICE, CPT Wood should have been aware of the potential for detainee abuse at Abu Ghraib. As the Officer-in-Charge (OIC) she was in a position to take steps to prevent further abuse. Her failure to do so allowed the abuse by Soldiers and civilians to go undetected and unchecked.
- Failed to assist in gaining control of a chaotic situation during the IP Roundup, even after SGT Eckroth approached her for help.
- Failed to provide proper supervision. Should have been more alert due to the following incidents:
 - An ongoing investigation on the 519 MI BN in Afghanistan.
 - Prior reports of 519 MI BN interrogators conducting unauthorized interrogations.
 - SOLDIER29's reported use of nudity and humiliation techniques.
 - Quick Reaction Force (QRF) allegations of detainee abuse by 519th MI Soldiers.
- Failed to properly review interrogation plans which clearly specified the improper use of nudity and isolation in interrogations and as punishment.
- Failed to ensure that Soldiers were properly trained on interrogation techniques and operations.
- Failed to adequately train Soldiers and civilians on the ICRP.

(U) **Recommendation:** This information should be forwarded to CPT Wood's chain of command for appropriate action.

(6) (U) **Finding:** SOLDIER-28, Guantanamo Base Team Chief, 260th MI Battalion. A preponderance of evidence supports that SOLDIER28 did, or failed to do, the following:

- Failed to report detainee abuse when he was notified by SOLDIER-11 that a detainee was observed in a cell naked, hooded, and whimpering, and when SOLDIER-11 reported an interrogator made a detainee pull his jumpsuit down to his waist.

(U) **Recommendation:** This information should be forwarded to SOLDIER-28's chain of command for appropriate action.

(7) (U) **Finding:** SOLDIER-23, Operations Section, ICE, JIDC, 325 MI BN. A preponderance of evidence supports that SOLDIER23 did, or failed to do, the following:

SUBJECT: (U) AR 15-6 Investigation of the Abu Ghraib Detention Facility and
205th MI Brigade

- Failed to prevent detainee abuse and permitted the unauthorized use of dogs and unauthorized interrogations during the IP Roundup. As the second senior MI officer during the IP Roundup, his lack of leadership contributed to detainee abuse and the chaotic situation during the IP Roundup.
- Failed to properly supervise and ensure Soldiers and civilians followed the ICRP.
- Failed to properly review interrogation plans which clearly specified the improper use of nudity and isolation as interrogation techniques and punishment.

(U) **Recommendation:** This information should be forwarded to SOLDIER23' chain of command for appropriate action.

(8) (U) **Finding:** **SOLDIER-14, Night Shift OIC, ICE, JIDC, 519 MI BN.** A preponderance of evidence supports that SOLDIER-14 did, or failed to do, the following:

- Failed to properly supervise and ensure Soldiers and civilians followed the ICRP.
- Failed to provide proper supervision. SOLDIER-14 should have been aware of the potential for detainee abuse at Abu Ghraib: The following incidents should have increased his diligence in overseeing operations:
 - An ongoing investigation of the 519 MI BN in Afghanistan.
 - Allegations by a female detainee that 519 MI BN interrogators sexually assaulted her. The Soldiers received non-judicial punishment for conducting unauthorized interrogations.
 - SOLDIER-29's reported use of nudity and humiliation techniques.
 - Quick Reaction Force (QRF) allegations of detainee abuse by 519 MI BN Soldiers.
- Failed to properly review interrogation plans which clearly specified the improper use of nudity and isolation as punishment.

(U) **Recommendation:** This information should be forwarded to SOLDIER-14's chain of command for appropriate action.

SUBJECT: (U) AR 15-6 Investigation of the Abu Ghraib Detention Facility and
205th MI Brigade

(9) (U) **Finding:** **SOLDIER-15, Interrogator, 66 MI GP.** A preponderance of evidence supports that SOLDIER15 did, or failed to do, the following:

- Failed to report detainee abuse. He witnessed SSG Frederick twisting the handcuffs of a detainee causing pain and covering the detainee's nose and mouth to restrict him from breathing.
 - Witnessed during that same incident, CIVILIAN-11 threaten a detainee by suggesting he would be turned over to SSG Frederick for further abuse if he did not cooperate.

(U) **Recommendation:** This information should be forwarded to SOLDIER-15's chain of command for appropriate action.

(10) (U) **Finding:** **SOLDIER-22, 302d MI Battalion.** A preponderance of evidence supports that SOLDIER22 did, or failed to do, the following:

- Failed to report detainee abuse.
 - He was made aware by SOLDIER-25 of an incident where three detainees were abused by MPs (Reference Annex I, Appendix 1, Photographs M36-37, M39-41).
 - He was made aware by SOLDIER-25 of the use of dogs to scare detainees.
 - He overheard Soldiers stating that MPs were using detainees as "practice dummies;" striking their necks and knocking them unconscious.
 - He was made aware of MPs conducting "PT" (Physical Training) sessions with detainees and MI personnel participating:
- Failed to obey a direct order. He interfered with this investigation by talking about the investigation, giving interviews to the media, and passing the questions being asked by investigators to others via a website.

(U) **Recommendation:** This information should be forwarded to SOLDIER-22's chain of command for appropriate action.

SUBJECT: (U) AR 15-6 Investigation of the Abu Ghraib Detention Facility and
205th MI Brigade

(11) (U) **Finding: SOLDIER-10, Analyst, 325 MI BN (currently attached to HHC, 504 MI BDE)**. A preponderance of evidence supports that SOLDIER10 did, or failed to do, the following:

- Actively participated in abuse when he threw water on three detainees who were hand-cuffed together and made to lie on the floor of the detention facility (Reference Annex I, Appendix 1, Photographs M36-37).
- Failed to stop detainee abuse in the above incident and in the incident when SOLDIER-29 stripped a detainee of his clothes and walked the detainee naked from an interrogation booth to Camp Vigilant during a cold winter day.
- Failed to report detainee abuse.

(U) **Recommendation:** This information should be forwarded to SOLDIER-10's chain of command for appropriate action.

(12) (U) **Finding: SOLDIER-17, Interrogator, 2d MI Battalion**. A preponderance of evidence supports that SOLDIER17 did, or failed to do, the following:

- Failed to report the improper use of dogs. He saw an un-muzzled black dog go into a cell and scare two juvenile detainees. The dog handler allowed the dogs to “go nuts” on the juveniles (Reference Annex I, Appendix 1, Photograph D-48).
- Failed to report inappropriate actions of dog handlers. He overheard Dog Handlers state they had a competition to scare detainees to the point they would defecate. They claimed to have already made several detainees urinate when threatened by their dogs.

(U) **Recommendation:** This information should be forwarded to SOLDIER-17's chain of command for appropriate action.

SUBJECT: (U) AR 15-6 Investigation of the Abu Ghraib Detention Facility and
205th MI Brigade

(13) (U) **Finding:** **SOLDIER-19, Interrogator, 325 MI BN.** A preponderance of evidence supports that SOLDIER-19 did, or failed to do, the following:

- Abused detainees:
 - Actively participated in the abuse of three detainees depicted in photographs (Reference Annex I, Appendix 1, Photographs M36-37, M39-41). He threw a Foam-ball at their genitals and poured water on the detainees while they were bound, nude, and abused by others.
 - Turned over a detainee to the MPs with apparent instructions for his abuse. He returned to find the detainee naked and hooded on the floor whimpering.
 - Used improper interrogation techniques. He made a detainee roll down his jumpsuit and threatened the detainee with complete nudity if he did not cooperate.
- Failed to stop detainee abuse in the above incidents.
- Failed to report detainee abuse for above incidents.

(U) **Recommendation:** This information should be forwarded to SOLDIER-19's chain of command for appropriate action.

(14) (U) **Findings:** **SOLDIER-24, Analyst, 325 MI BN (currently attached to HHC, 504 MI BDE).** A preponderance of evidence supports that SOLDIER24 did, or failed to do, the following:

- Failed to report detainee abuse. He was present during the abuse of detainees depicted in photographs (Reference Annex I, Appendix 1, Photographs M36-37, M39, M41).
- Failed to stop detainee abuse.

(U) **Recommendation:** This information should be forwarded to SOLDIER-24's chain of command for appropriate action.

SUBJECT: (U) AR 15-6 Investigation of the Abu Ghraib Detention Facility and
205th MI Brigade

(15) (U) **Findings:** SOLDIER-25, Interrogator, 321st MI BN. A preponderance of evidence supports that SOLDIER25 did, or failed to do, the following:

- Failed to report detainee abuse.
 - She saw Dog Handlers use dogs to scare detainees. She “thought it was funny” as the detainees would run into their cells from the dogs.
 - She was told by SOLDIER-24 that the detainees who allegedly had raped another detainee were handcuffed together, naked, in contorted positions, making it look like they were having sex with each other.
 - She was told that MPs made the detainees wear women’s underwear.
- Failed to stop detainee abuse.

(U) **Recommendation:** This information should be forwarded to SOLDIER-25's chain of command for appropriate action.

(16) (U) **Finding:** SOLDIER-29, Interrogator, 66 MI GP. A preponderance of evidence supports that SOLDIER29 did, or failed to do, the following:

- Failed to report detainee abuse.
 - She saw CPL Graner slap a detainee.
 - She saw a computer screen saver depicting naked detainees in a “human pyramid.”
 - She was aware MPs were taking photos of detainees.
 - She knew MPs had given a detainee a cold shower, made him roll in the dirt, and stand outside in the cold until he was dry. The detainee was then given another cold shower.
- Detainee abuse (Humiliation). She violated interrogation rules of engagement by stripping a detainee of his clothes and walking him naked from an interrogation booth to Camp Vigilant on a cold winter night.
- Gave MPs instruction to mistreat/abuse detainees.
 - SOLDIER2-9's telling MPs (SSG Frederick) when detainees had not cooperated in an interrogation appeared to result in subsequent abuse.
 - One of the detainees she interrogated was placed in isolation for several days and allegedly abused by the MPs. She annotated in an interrogation report (IN-AG00992-DETAINEE-08-04) that a “direct approach” was used with “the reminder of the unpleasantness that occurred the last time he lied to us.”

(U) **Recommendation:** This information should be forwarded to SOLDIER-29's chain of command for appropriate action.

SUBJECT: (U) AR 15-6 Investigation of the Abu Ghraib Detention Facility and
205th MI Brigade

(17) (U) Findings: **SOLDIER-08, Dog Handler, Abu Ghraib, 42 MP Detachment, 16 MP BDE (ABN).** A preponderance of evidence supports that SOLDIER08 did, or failed to do, the following:

- Inappropriate use of dogs. Photographs (Reference Annex I, Appendix 1, D46, D52, M149-151) depict SOLDIER-08 inappropriately using his dog to terrorize detainees.
- Abused detainees. SOLDIER-08 had an on-going contest with SOLDIER-27, another dog handler, to scare detainees with their dogs in order to see who could make the detainees urinate and defecate first.

(U) **Recommendation:** This information should be forwarded to SOLDIER-08's chain of command for appropriate action.

(18) (U) Findings: **SOLDIER34, 372 MP CO.** A preponderance of evidence supports that SOLDIER34 did, or failed to do, the following:

- Failed to report detainee abuse. He was present during the abuse of detainees depicted in photographs (Reference Annex I, Appendix 1, Photographs M36-37, M39-41).
- Failed to stop detainee abuse.

(U) **Recommendation:** This information should be forwarded to SOLDIER34's chain of command for appropriate action.

(19) (U) Findings: **SOLDIER-27, 372 MP CO.** A preponderance of evidence supports that SOLDIER27 did, or failed to do, the following:

- Actively participated in detainee abuse.
 - During the medical treatment (stitching) of a detainee, he stepped on the chest of the detainee (Reference Annex I, Appendix 1, Photograph M163).
 - He participated in the abuse of naked detainees depicted in photographs (Reference Annex I, Appendix 1, Photographs M36-37, M39-41).
- Failed to stop detainee abuse.

(U) **Recommendation:** This information should be forwarded to SOLDIER27's chain of command for appropriate action.

SUBJECT: (U) AR 15-6 Investigation of the Abu Ghraib Detention Facility and
205th MI Brigade

(20) (U) **Findings:** SOLDIER-27, Dog Handler, Abu Ghraib, 523 MP Detachment. A preponderance of evidence supports that SOLDIER27 did, or failed to do, the following:

- Inappropriate use of dogs. Photographs (Reference Annex I, Appendix 1, Photographs D46, D48, M148, M150, M151, M153, Z1, Z3-6) depict SOLDIER-27 inappropriately using his dog terrorizing detainees.
- Detainee abuse. SOLDIER-27 had an on-going contest with SOLDIER-08, another dog handler, to scare detainees with their dogs and cause the detainees to urinate and defecate.
- Led his dog into a cell with two juvenile detainees and let his dog go “nuts.” The two juveniles were yelling and screaming with the youngest one hiding behind the oldest.

(U) **Recommendation:** This information should be forwarded to SOLDIER-27's chain of command for appropriate action.

(21) (U) **Finding:** SOLDIER-20, Medic, 372 MP CO. A preponderance of evidence supports that SOLDIER20 did, or failed to do, the following:

- Failed to report detainee abuse.
 - When called to assist a detainee who had been shot in the leg, he witnessed CPL Graner hit the detainee in his injured leg with a stick.
 - He saw the same detainee handcuffed to a bed over several days, causing great pain to the detainee as he was forced to stand.
 - He saw the same detainee handcuffed to a bed which resulted in a dislocated shoulder.
 - He saw pictures of detainees being abused (stacked naked in a “human pyramid”).

(U) **Recommendation:** This information should be forwarded to SOLDIER-20's chain of command for appropriate action.

(22) (U) **Finding:** SOLDIER-01, Medic, Abu Ghraib. A preponderance of evidence supports that SOLDIER01 did, or failed to do, the following:

- Failed to report detainee abuse. She saw a "human pyramid" of naked Iraqi prisoners, all with sandbags on their heads when called to the Hard Site to provide medical treatment.

(U) **Recommendation:** This information should be forwarded to SOLDIER-01's chain of command for appropriate action.

(23) (U) **Finding:** CIVILIAN-05, CACI employee. A preponderance of evidence supports that CIVILIAN-05 did, or failed to do, the following:

SUBJECT: (U) AR 15-6 Investigation of the Abu Ghraib Detention Facility and
205th MI Brigade

- He grabbed a detainee (who was handcuffed) off a vehicle and dropped him to the ground. He then dragged him into an interrogation booth and as the detainee tried to get up, CIVILIAN-05 would yank the detainee very hard and make him fall again.
- Disobeyed General Order Number One; drinking alcohol while at Abu Ghraib.
- Refused to take instructions from a Tiger Team leader and refused to take instructions from military trainers.
 - When confronted by SSG Neal, his Tiger Team leader, about his inadequate interrogation techniques, he replied, "I have been doing this for 20 years and I do not need a 20 year old telling me how to do my job."
 - When placed in a remedial report writing class because of his poor writing, he did not pay attention to the trainer and sat in the back of the room facing away from the trainer.

(U) **Recommendation:** This information should be forwarded to the Army General Counsel for determination of whether CIVILIAN-05 should be referred to the Department of Justice for prosecution. This information should be forwarded to the Contracting Officer (KO) for appropriate contractual action.

(24) (U) **Finding:** CIVILIAN-10, Translator, Titan employee. After a thorough investigation, we found no direct involvement in detainee abuse by CIVILIAN-10. Our investigation revealed CIVILIAN-10 had a valid security clearance until it was suspended.

(U) **Recommendation:** This information should be forwarded to Titan via the KO. CIVILIAN-10 is cleared of any wrong doing and should retain his security clearance.

SUBJECT: (U) AR 15-6 Investigation of the Abu Ghraib Detention Facility and
205th MI Brigade

(25) (U) **Finding:** CIVILIAN-11, Interrogator, CACI employee. A preponderance of evidence supports that CIVILIAN11 did, or failed to do, the following:

- Detainee abuse.
 - He encouraged SSG Frederick to abuse Iraqi Police detained following a shooting incident (IP Roundup). SSG Frederick twisted the handcuffs of a detainee being interrogated; causing pain.
 - He failed to prevent SSG Frederick from covering the detainee's mouth and nose restricting the detainee from breathing:
- Threatened the Iraqi Police "with SSG Frederick." He told the Iraqi Police to answer his questions or he would bring SSG Frederick back into the cell.
- Used dogs during the IP Roundup in an unauthorized manner. He told a detainee, "You see that dog there, if you do not tell me what I want to know, I'm going to get that dog on you."
- Placed a detainee in an unauthorized stress position (Reference Annex I, Appendix 2, Photograph "Stress Positions"). CIVILIAN-11 is photographed facing a detainee who is in a stress position on a chair with his back exposed. The detainee is in a dangerous position where he might fall back and injure himself.
- Failed to prevent a detainee from being photographed.

(U) **Recommendation:** This information should be forwarded to the Army General Counsel for determination of whether CIVILIAN-11 should be referred to the Department of Justice for prosecution. This information should be forwarded to the KO for appropriate contractual action.

SUBJECT: (U) AR 15-6 Investigation of the Abu Ghraib Detention Facility and
205th MI Brigade

(26) (U) **Finding:** CIVILIAN-16, Translator, Titan employee. A preponderance of evidence supports that CIVILIAN-16 did, or failed to do, the following:

- Failed to report detainee abuse.
 - She participated in an interrogation during the IP Roundup, where a dog was brought into a cell in violation of approved ICRP.
 - She participated in the interrogation of an Iraqi Policeman who was placed in a stress position; squatting backwards on a plastic lawn chair. Any sudden movement by the IP could have resulted in injury (Reference Annex I, Appendix 2, Photograph “Stress Positions”).
 - She was present during an interrogation when SSG Frederick twisted the handcuffs of a detainee, causing the detainee pain.
 - She was present when SSG Frederick covered an IP’s mouth and nose, restricting the detainee from breathing.
- Failed to report threats against detainees.
 - She was present when CIVILIAN-11 told a detainee, “You see that dog there, if you do not tell me what I want to know, I’m going to get that dog on you.”
 - She was present when CIVILIAN-11 threatened a detainee “with SSG Frederick.”

(U) **Recommendation:** This information should be forwarded to the Army General Counsel for determination of whether CIVILIAN-16 should be referred to the Department of Justice for prosecution. This information should be forwarded to the KO for appropriate contractual action.

(27) (U) **Finding:** CIVILIAN-17, Interpreter, Titan employee. A preponderance of evidence supports that CIVILIAN-17 did, or failed to do, the following:

- Actively participated in detainee abuse.
 - He was present during the abuse of detainees depicted in photographs (Reference Annex I, Appendix 1, Photographs M36-37, M39, M41).
 - A detainee claimed that CIVILIAN-17 (sic), an interpreter, hit him and cut his ear which required stitches.
 - Another detainee claimed that someone fitting CIVILIAN-17’s description raped a young detainee.
- Failure to report detainee abuse.
- Failure to stop detainee abuse.

(U) **Recommendation:** This information should be forwarded to the Army General Counsel for determination of whether CIVILIAN-17 should be referred to the Department of Justice for prosecution. This information should be forwarded to the KO for appropriate contractual action.

SUBJECT: (U) AR 15-6 Investigation of the Abu Ghraib Detention Facility and
205th MI Brigade

(28) (U) **Finding:** CIVILIAN-21, Interrogator, CACI employee. A preponderance of evidence supports that CIVILIAN-21 did, or failed to do, the following:

- Inappropriate use of dogs. SOLDIER-26 stated that CIVILIAN-21 used a dog during an interrogation and the dog was unmuzzled. SOLDIER-25 stated she once saw CIVILIAN-21 standing on the second floor of the Hard Site, looking down to where a dog was being used against a detainee, and yelling to the MPs "Take him home." The dog had torn the detainee's mattress. He also used a dog during an interrogation with SSG Aston but stated he never used dogs.
- Detainee abuse. CPT Reese stated he saw "NAME" (his description of "NAME") matched CIVILIAN-21) push (kick) a detainee into a cell with his foot.
- Making false statements. During questioning about the use of dogs in interrogations, CIVILIAN-21 stated he never used them.
- Failed to report detainee abuse. During an interrogation, a detainee told SOLDIER-25 and CIVILIAN-21 that CIVILIAN-17, an interpreter, hit him and cut his ear which required stitches. SOLDIER-25 stated she told CIVILIAN-21 to annotate this on the interrogation report. He did not report it to appropriate authorities.
- Detainee Humiliation.
 - CIVILIAN-15 stated he heard CIVILIAN-21 tell several people that he had shaved the hair and beard of a detainee and put him in red women's underwear. CIVILIAN-21 was allegedly bragging about it.
 - CIVILIAN-19 stated he heard OTHER AGENCY EMPLOYEE02 laughing about red panties on detainees.

(U) **Recommendation:** This information should be forwarded to the Army General Counsel for determination of whether CIVILIAN-21 should be referred to the Department of Justice for prosecution. This information should be forwarded to the KO for appropriate contractual action.

SUBJECT: (U) AR 15-6 Investigation of the Abu Ghraib Detention Facility and
205th MI Brigade

(29) (U) **Finding:** There were several personnel who used clothing removal, improper isolation, or dogs as techniques for interrogations in violation of the Geneva Conventions. Several interrogators documented these techniques in their interrogation plans and stated they received approval from the JIDC, Interrogation Control Element. The investigative team found several entries in interrogation reports which clearly specified clothing removal; however, all personnel having the authority to approve interrogation plans claim they never approved or were aware of clothing removal being used in interrogations. Also found were interrogation reports specifying use of isolation, "the Hole." While the Commander, CJTF-7 approved "segregation" on 25 occasions, this use of isolation sometimes trended toward abuse based on sensory deprivation and inhumane conditions. Dogs were never approved, however on several occasions personnel thought they were. Personnel who committed abuse based on confusion regarding approvals or policies are in need of additional training.

(U) **Recommendation:** This information should be forwarded to the Soldiers' chain of command for appropriate action.

CIVILIAN-14 (formally with 368 Military Intelligence Battalion)
SOLDIER-04, 500 Military Intelligence Group
SOLDIER-05, 500 Military Intelligence Group
SOLDIER-03, GTMO Team, 184 Military Intelligence Company
SOLDIER-13, 66 Military Intelligence Group
SOLDIER-18, 66 Military Intelligence Group
SOLDIER-02, 66 Military Intelligence Group
SOLDIER-11 6 Battalion 98 Division (IT)
SOLDIER-16, 325 Military Intelligence Battalion
SOLDIER-30, 325 Military Intelligence Battalion
SOLDIER-26, 320 Military Police Battalion
SOLDIER-06, 302 Military Intelligence Battalion
SOLDIER-07, 325 Military Intelligence Battalion
SOLDIER-21, 325 Military Intelligence Battalion
SOLDIER-09, 302 Military Intelligence Battalion
SOLDIER-12, 302 Military Intelligence Battalion
CIVILIAN-20, CACI Employee

SUBJECT: (U) AR 15-6 Investigation of the Abu Ghraib Detention Facility and
205th MI Brigade

(30) (U) **Finding:** In addition to SOLDIER-20 and SOLDIER01, medical personnel may have been aware of detainee abuse at Abu Ghraib and failed to report it. The scope of this investigation was MI personnel involvement. SOLDIER-20 and SOLDIER-01 were cited because sufficient evidence existed within the scope of this investigation to establish that they were aware of detainee abuse and failed to report it. Medical records were requested, but not obtained, by this investigation. The location of the records at the time this request was made was unknown.

(U) **Recommendation:** An inquiry should be conducted into 1) whether appropriate medical records were maintained, and if so, were they properly stored and collected and 2) whether medical personnel were aware of detainee abuse and failed to properly document and report the abuse.

(31) (U) **Finding:** A preponderance of the evidence supports that SOLDIER-31, SOLDIER-32, and SOLDIER-33 participated in the alleged sexual assault of a female detainee by forcibly kissing her and removing her shirt (Reference CID Case-0216-03-CID259-6121). The individuals received non-judicial punishment for conducting an unauthorized interrogation, but were not punished for the alleged sexual assault.

(U) **Recommendation:** CID should review case # 0216-03-CID259-61211 to determine if further investigation is appropriate. The case should then be forwarded to the Soldiers' chain of command for appropriate action.

(32) (U) **Finding:** An unidentified person, believed to be a contractor interpreter, was depicted in six photographs taken on 25 October 2003 showing the abuse of three detainees. The detainees were nude and handcuffed together on the floor. This investigation could not confirm the identity of this person; however, potential leads have been passed to and are currently being pursued by CID.

(U) **Recommendation:** CID should continue to aggressively pursue all available leads to identify this person and determine the degree of his involvement in detainee abuse.

SECRET//NOFORN//X1

SUBJECT: (U) AR 15-6 Investigation of the Abu Ghraib Detention Facility and
205th MI Brigade

7. (U) Personnel Listing. Deleted in accordance with the Privacy Act and 10 USC §130b

SECRET//NOFORN//X1

SUBJECT: (U) AR 15-6 Investigation of the Abu Ghraib Detention Facility and
205th MI Brigade

8. (U) Task Force Members.

LTC Anthony R. CIVILIAN08 Command	Investigating Officer	HQs, Training and Doctrine
MG George R. Fay	Investigating Officer	HQs, Dept of the Army, G2
Mr. Thomas A. Gandy	Deputy	HQs, Dept of the Army, G2
LTC Phillip H. Bender	Chief Investigator	HQs, Dept of the Army, G2
LTC Michael Benjamin	Legal Advisor	TJAG
MAJ(P) Maricela Alvarado	Executive Officer	HQs, Dept of the Army, G2
CPT Roseanne M. Bleam	Staff Judge Advocate, CJTF-7	CJTF-7 (MNF-I) SJA
CW5 Donald Marquis	SME – Training & Doctrine	HQs, US Army Intelligence Center
CW3 Brent Pack	CID Liaison	US Army CID Command
CW2 Mark Engan	Investigator – Baghdad Team	HQs, 308 th MI Bn, 902 nd MI Group
SGT Patrick D. Devine	All Source Analyst	ACIC, 310 th MI Bn, 902 nd MI Group
CPL Ryan Hausterman	Investigator – Baghdad Team	HQs, 310 th MI Bn, 902 nd MI Group
Mr. Maurice J. Sheley	Investigator	HQs, US Army INSCOM
Mr. Michael P. Scanland	Investigator	HQs, 902 nd MI Group
Mr. Claude B. Benner	Investigative Review	ACIC, 902 nd MI Group
Mr. Michael Wright	Investigator	HQs, 308 th MI Bn, 902 nd MI Group
Mr. Scott Robertson	Investigator	HQs, Dept of the Army, G2
Mr. Paul Stark	Chief of Analysis	ACIC, 310 th MI Bn, 902 nd MI Group
Mr. Kevin Brucie	Investigator – Baghdad Team	Det 13, FCA, 902 nd MI Group
Ms. Linda Flanigan	Analyst	ACIC, 310 th MI Bn, 902 nd MI Group
Mr. Albert Scott	Cyber-Forensic Analyst	HQs, 310 th MI Bn, 902 nd MI Group
Ms. Saoirse Spain	Analyst	ACIC, 310 th MI Bn, 902 nd MI group
Mr. Albert J. McCarn Jr.	Chief of Logistics	HQs, Dept of the Army, G2
Ms. Cheryl Clowser	Administrator	HQs, Dept of the Army, G2
Mr. Alfred Moreau	SME – Contract Law	HQs, Dept of the Army, OTJAG
Mr. Rudolph Garcia	Senior Editor	HQs, Dept of the Army, G2

Contract Services provided by Object Sciences Corp. and SYTEX

SUBJECT: (U) AR 15-6 Investigation of the Abu Ghraib Detention Facility and
205th MI Brigade

9. (U) Acronyms.

2 MI BN	2d Military Intelligence Battalion
B/321 MI BN	B Company, 321st Military Intelligence Battalion
B/325 MI BN	B Company, 325th Military Intelligence Battalion
A/205 MI BN	A Company, 205th Military Intelligence Battalion
115 MP BN	115th Military Police Battalion
165 MI BN	165th Military Intelligence Battalion
205 MI BDE	205th Military Intelligence Brigade
229 MP CO	229th Military Police Battalion
320 MP BN	320th Military Police Battalion
320 MP CO	320th Military Police Company
323 MI BN	323d Military Intelligence Battalion
325 MI BN	325th Military Intelligence Battalion
372 MP CO	372d Military Police Company
377 TSC	377th Theater Support Command
400 MP BN	400th Military Police Battalion
470 MI GP	470th Military Intelligence Group
447 MP CO	447th Military Police Company
500 MI GP	500th Military Intelligence Group
504 MI BDE	504th Military Intelligence Battalion
519 MI BN	519th Military Intelligence Battalion
66 MI GP	66th Military Intelligence Group
670 MP CO	670th Military Police Company
72 MP CO	72d Military Police Company
800 MP BDE	800th Military Police Brigade
870 MP CO	870th Military Police Company
1SG	First Sergeant
A/519 MI BN	A Company, 519th Military Intelligence Battalion
AAR	After Action Report
AFJI	Air Force Joint Instructor
AG	Abu Ghraib
ANCOC	Advanced Non-Commission Officer's Course
AR	Army Regulation
ATSD (IO)	Assistant to the Secretary of Defense for Intelligence Oversight
BDE	Brigade
BG	Brigadier General
BIAP	Baghdad International Airport
BN	Battalion
BNCOC	Basic Non-Commission Officer's Course
BPA	Blanket Purchase Agreement
C2X	Command and Control Exercise

SUBJECT: (U) AR 15-6 Investigation of the Abu Ghraib Detention Facility and
205th MI Brigade

CALL	Center for Army Lessons Learned
CENTCOM	US Central Command
CG	Commanding General
CHA	Corps Holding Area
CIA	Central Intelligence Agency
CID	Criminal Investigation Command
CJCS-I	Chairman, Joint Chief of Staff Instruction
CJTF-7	Combined Joint Task Force 7
CM&D	Collection Management and Dissemination
COL	Colonel
COR	Contracting Officers Representative
CP	Collection Point
CPA	Coalition Provisional Authority
CPL	Corporal
CPT	Captain
CSH	Combat Support Hospital
DA	Department of the Army
DAIG	Department of the Army Inspector General
DCI	Director of Central Intelligence
DCG	Deputy Commanding General
DIAM	Defense Intelligence Agency Manual
DoD	Department of Defense
1LT	First Lieutenant
CASH	Combat Army Surgical Hospital
DIA	Defense Intelligence Agency
KO	Contracting Officer
DOJ	Department of Justice
DRA	Detention Review Authority
DRB	Detainee Release Branch
EPW	Enemy Prisoner of War
FM	Field Manual
FOB	Forward Operating Base
FRAGO	Fragmentary Order
G-3	Army Training Division
GCIV	Geneva Conventions IV
GP	Group
GSA	General Services Administration
GTMO	Guantanamo Naval Base, Cuba
GWOT	Global War On Terrorism
HQ	Headquarters
HUMINT	Human Intelligence
IAW	In Accordance With
ICE	Interrogation and Control Element
ICRC	International Committee of the Red Cross

SUBJECT: (U) AR 15-6 Investigation of the Abu Ghraib Detention Facility and
205th MI Brigade

ICRP	Interrogation and Counter-Resistance Policies
IET	Initial Entry Training
ID	Infantry Division
IG	Inspector General
IMINT	Imagery Intelligence
INSCOM	Intelligence and Security Command
IP	Iraqi Police
IR	Interment/Resettlement
IROE	Interrogation Rules Of Engagement
ISCT	Interrogation Support to Counterterrorism
ISG	Iraqi Survey Group
JA	Judge Advocate
JCS	Joint Chiefs of Staff
JIDC	Joint Interrogation and Detention Center
JTF-GTMO	Joint Task Force Guantanamo
MAJ	Major
MCO	Marine Corps Order
LTC	Lieutenant Colonel
LTG	Lieutenant General
MFR	Memorandum For Record
MG	Major General
MI	Military Intelligence
MIT	Mobile Interrogation Team
MOS	Military Occupational Specialty
MOU	Memorandum of Understanding
MP	Military Police
MRE	Meals Ready to Eat
MSC	Major Subordinate Command
MSG	Master Sergeant
MTT	Mobile Training Team
NCO	Non-Commissioned Officer
NCOIC	Non-Commissioned Officer In Charge
OER	Officer Evaluation Report
OGA	Other Government Agency
OGC	Office Of General Counsel
OIC	Officer In Charge
OIF	Operation Iraqi Freedom
OPORD	Operations Order
OPNAVINST	Office of the Chief of Naval Operations Instructions
OSJA	Office Of the Staff Judge Advocate
OVB	Operation Victory Bounty
RP	Retained Personnel
SASO	Stability And Support Operations
SECARMY	Secretary of the Army

SUBJECT: (U) AR 15-6 Investigation of the Abu Ghraib Detention Facility and
205th MI Brigade

SECDEF	Secretary of Defense
SFC	Sergeant First Class
SGT	Sergeant
SIGINT	Signals Intelligence
SITREP	Situation Report
HMMWV	High-Mobility, Multipurpose Wheeled Vehicle
PFC	Private First Class
MA1	Master at Arms 1
MA2	Master at Arms 2
PVT	Private
QRF	Quick Reaction Force
SJA	Staff Judge Advocate
SOF	Special Operations Forces
SOP	Standard Operating Procedure
SOUTHCOM	US Southern Command
SOW	Statement of Work
SSG	Staff Sergeant
TACON	Tactical Control
THT	Tactical HUMINT Team
TRADOC	Training and Doctrine Command
TTP	Tactics, Techniques, and Procedures
UCMJ	Uniform Code Of Military Justice
USAIC	US Army Intelligence Center
USAR	US Army Reserve
VFR	Visual Flight Rules
E-6	Enlisted Grade 6 (Staff Sergeant)
E-7	Enlisted Grade 7 (Sergeant First Class)
E-5	Enlisted Grade 5 (Sergeant)
96B	Intelligence Analyst
NBC	National Business Center
FSS	Federal Supply Schedule
POC	Point of Contact
DAIG	Department of the Army Inspector General
97E	Human Intelligence Collector
351E	Interrogation Warrant Officer
FBI	Federal Bureau of Investigation
ISN	Internee Serial Number
JTF-21	Joint Task Force – 21
TF-121	Task Force – 121
SEAL	Sea, Air, Land
SPC	Specialist
RFF	Request for Forces
TF-20	Task Force – 20
97B	Counterintelligence Agent

SUBJECT: (U) AR 15-6 Investigation of the Abu Ghraib Detention Facility and
205th MI Brigade

CM&D	Collection, Management and Dissemination
JIG	Joint Intelligence Group
351B	Counterintelligence Warrant Officer
PT	Physical Training
IRF	Internal Reaction Force