



ESCORTS

RAILWAY EQUIPMENT DIVISION

Transformation through
Engineering and Innovation

COUPLERS



COUPLERS

Escorts has been a supplier of advanced Coupler systems to Indian Railways to haul wide variety of rakes such as High Speed Trains, Metros, EMUs, MEMUs & DMUs for over the past 30 years. We also supply high capacity couplers for locomotives which include GM/EMD Locos and ALCO Locos.

We are credited for the introduction of Balanced Draft Gear to the Indian Railways. Our Coupler Systems confirm to the stringent specifications of Indian Railways and have proven record in minimizing the longitudinal jerks. Thus, ensuring excellent ride comfort to the Passengers. Apart from ride quality our couplers have anti-climb feature as well.

We have been one of the largest supplier of couplers, with 70% market share for AAR-H Type couplers and 50% market share for Schauku Couplers in Indian market. Our efforts have been to continuously improve our products and develop newer ones to cater to varied needs of improved

energy absorbing systems that easily accommodate the vehicle dynamics.

Our rigorous testing standards, quality controls and dedicated team of engineers have been ensuring that our products match the customer expectations for the past 3 decades.

APPLICATION

1. Passenger coaches

- AAR-H type Couplers with Balanced Draft Gear for high speed trains up to 160 kmph
- AAR-H Type with transition screw coupling for coupling either Center Buffer Coupler or Hook Type Couplers
- Automatic and Semi-Automatic Schauku Couplers for EMU/DMU and Metro Coaches

2. Locomotives

- AAR-H type Couplers for GM/EMD and ALCO Locomotives

AAR-H COUPLERS FOR PASSENGER COACHES

Escorts AAR-H type coupler has been developed in-house for passenger coach application. It is a high tensile tight lock centre buffer coupler.

SALIENT FEATURES

- This coupler system offers anti-climb feature for safe journey of passengers in case of any derailment / accident
- Capable of hauling long rakes with full passenger safety and ride comfort
- All castings are passed through rigorous RT & MPI testing to filter the finest of the defects and pass only high class materials ensuring to meet high strength requirements
- Free & wide (horizontal & vertical) articulation on its pivot makes seamless coach movement on curves and grids
- Enhanced anti-creep property to avoid any undesired train parting while running at high speed
- Specially designed silent block used to connect coupler head to draft gear makes coupler operation jerk free
- Coupler along with Balanced Draft Gear ensures safe and comfortable ride

AAR-H COUPLER FOR LOCOMOTIVES

- GM-PAC LOCO COUPLER
- ALCO LOCO COUPLER

Escorts make Loco couplers have been designed with single pin clevis which provides couplability with both Center Buffer Couplers and Hook type Couplers.

They has been designed with a tensile load capacity of up to 400 Ton. Hence capable of hauling up to 26 coach rake.

SALIENT FEATURES

- Couplability with H and E type Couplers
- Ensure positive engagement even at low coupling speed
- Increased safety due to vertical interlocking provided between the couplers
- Improved vertical support for better couplability
- Improved bolt design on vertical support for longer life

AAR-H COUPLER WITH TRANSITION SCREW COUPLING

Escorts AAR-H type coupler with Transition screw coupling is capable of coupling with all types of couplers used in Indian Railways such as:

- H-Type coach or Loco Coupler
- Conventional coach screw coupler
- E-type Loco or wagon coupler
- Draw hook of EMU coach end

Its single pin clevis design makes it compact & easy to use.



AAR-H COUPLER FOR PASSENGER COACH



AAR-H COUPLER FOR ALCO LOCO

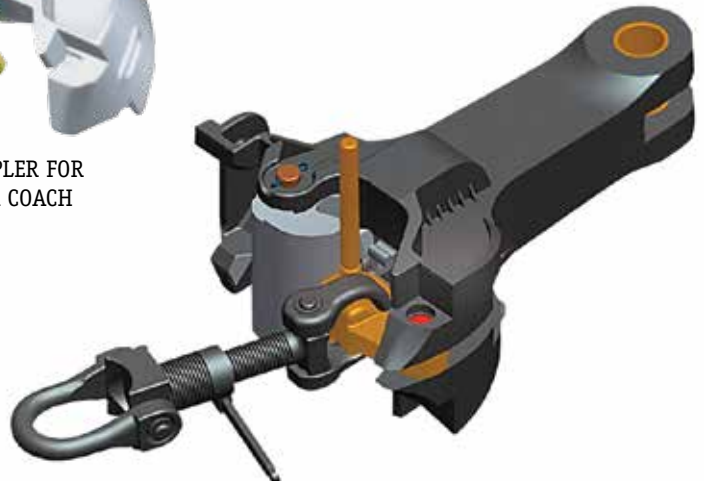

AAR-H COUPLER FOR GM PAC LOCO

SEMI-PERMANENT COUPLERS

Provide safe and permanent connection of multiple units.

Couplability of coupler halves is ensured by Adjustable Cup Sleeves.

SALIENT FEATURES

- Prevents overriding of coaches
- Uniform distribution of the draft load
- Jerk free start and braking
- Cushions axial movement of coaches
- Rigid and slack free connection

- Enables the connection of air pipes

APPLICATION

- EMU, MEMU and DEMU
- Any other suburban/mass rapid transport system

REFERENCES

- Indian Railways
- MRVC



SEMI PERMANENT COUPLER



AUTOMATIC COUPLERS

- The coupling has a generous gathering range because of conical and funnel shaped profile and guiding horn of the coupler face
Horizontal gathering range
up to 284 mm or 13° on either side.
Vertical gathering range
up to ± 75 mm
- A rigid connection is formed both vertically and horizontally by the coupler faces and locking system

- The Coupling system is designed to meet all performance and operating requirements of rail vehicles. Escorts is capable of supplying tailor made coupling systems for any application
- The draw gear arrangement serves to cushion the tensile and compressive loads produced under operation and to absorb the energy which is generated by train dynamics



AUTOMATIC COUPLER

BALANCED DRAFT GEAR FOR AAR-H COUPLER

The Balanced Draft Gear is an enhanced design which consists of 2 separate packs of elastomeric pads for buff and draw modes and aims to provide jerk free and smooth train operations.

The Balanced Draft gear arrangement can absorb energy of 35 kJ (minimum) under dynamic force application of 1600 kN (maximum force generated during the train dynamics). The elastomeric pads arrangement offers high damping factor, greater than 60% which helps smooth & vibration free movement of trains at high speeds.

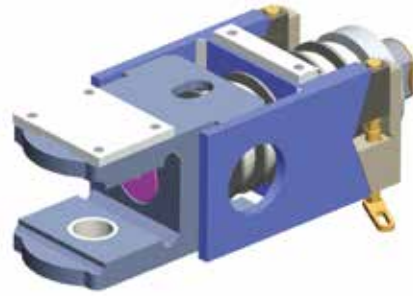

BALANCED DRAFT GEAR

STANDARD DRAFT GEAR FOR AAR-H COUPLER

Draw gear arrangement serves to cushion the tensile and compressive loads produced under train operation and absorbs the energy of 45kJ (minimum) which is generated during the train dynamics. This standard draft gear consists of a pack of highly non-linear elastomeric pads to absorb energy generated in longitudinal train dynamics.

Designed for high damping factor, greater than 60% makes train operation smooth in acceleration & deceleration and longitudinal train dynamics.

Draft gear with customer's specification can be designed and supplied.

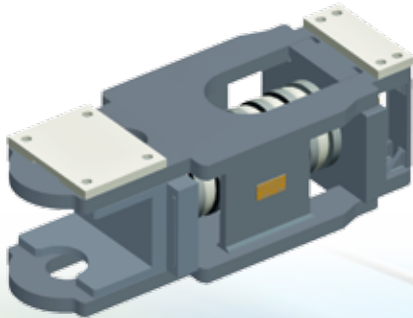

DRAFT GEAR





ESCORTS

RAILWAY EQUIPMENT DIVISION

Head Office & Works:

Plot No. 115, Sector 24,
Faridabad - 121 005
Haryana, (India)
Email: rail@escorts.co.in
Web: escortsrailwayproducts.com
Tel.: 91-129-2516382, 6608
Fax: 91-129-2232148

Mumbai Branch:

Times Square, Unit No. A-1,
A-Wing, 3rd floor,
Andheri Kurla Road,
Andheri East
Sakinaka, Mumbai - 400 059
Maharashtra, India
Email: mumbai@escorts.co.in
Tel.: +91-22-24218159
Fax: +91-22-24218153

Chennai Branch:

M-3, "M" Block, 3rd Avenue,
Anna Nagar East,
Chennai - 600 102
Tamil Nadu, India
Email: chennai@escorts.co.in
Tel.: +91-44-26287229
Fax: +91-44-26287341

Kolkata Branch:

South Western Wing,
9th Floor, "AC Market",
1, Shakespeare Sarani,
Kolkata - 700 071
West Bengal, India
Email: kolkata@escorts.co.in
Tel.: +91-33-22825191
Fax: +91-33-22814518