

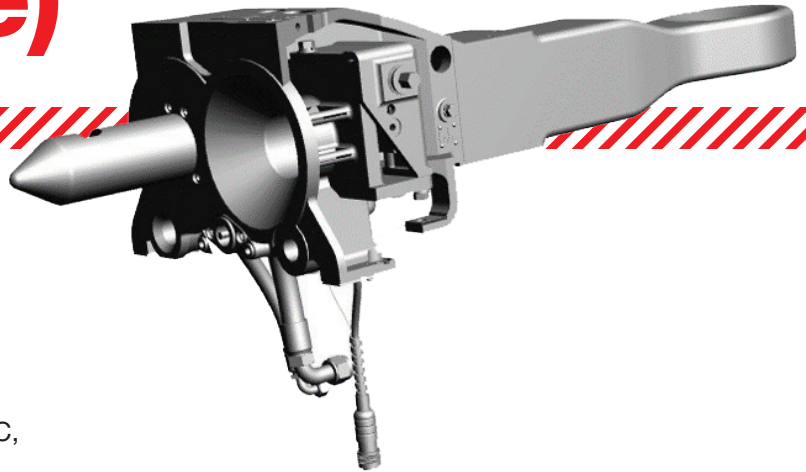

Connecting the
world's train
systems



Automatic Coupler Spear Type (N-Type)



The N-type coupler (sometimes referred to as the pin and cup coupler or spear coupler) is available in different spear sizes (2.5" and 3.5") and types N2, N2C, N2A, N3 and N6.



CUSTOMER BENEFITS :

- + Successful operational use for 50 years
- + Large gathering range compared to coupler head size
- + Provides AAR required strength
- + Potential for heavy duty application (2200kN draw force and 3600 kN compression force)
- + Draft gear and collision energy absorption optional



Target application:

- Mainline railways
- Metros
- Passenger Locomotives

References:

- **USA**
 - NYCTA / LIRR / NHRR / NJT / SAR
- **Taiwan**
 - Tapei Metro / M2
- **Brazil**
 - Rio

Specifications

Draw force	up to 2200 kN
Compression force	up to 3600 kN
Automatic coupling:	automatic coupling and uncoupling
Automatic air connection	two (MBP, MRP)
Electric coupler position:	top-mounted or side-mounted
Automatic coupling:	automatic coupling and uncoupling
Electric coupler actuation:	fixed mounted with button-style contacts or advance-retract



To discover the benefits the **Automatic Coupler Spear Type (N-Type)** can bring to your operations, please contact:

Schwab
Wabtec Corporation
Ebnatstrasse 150A, 8207 Schaffhausen, Suisse
Tel: +41 52 560 27 60
Email: info@wabtec.com
www.wabtec.com

