

## Durham Research Online

---

### Deposited in DRO:

02 April 2019

### Version of attached file:

Published Version

### Peer-review status of attached file:

Peer-reviewed

### Citation for published item:

Welton, L. and Harrison, T. and Batiuk, S. and Ünlü, E. and Janeway, B. and Karakaya, D. and Lipovitch, D. and Lumb, D. and Roames, J. (2019) 'Shifting networks and community identity at Tell Tayinat in the Iron I (ca. 12th to mid-10th Cent. BCE).', *American journal of archaeology.*, 123 (2). pp. 291-333.

### Further information on publisher's website:

<https://doi.org/10.3764/aja.123.2.0291>

### Publisher's copyright statement:

Deposited with the permission of the AJA and the Archaeological Institute of America.

### Additional information:

## Use policy

---

The full-text may be used and/or reproduced, and given to third parties in any format or medium, without prior permission or charge, for personal research or study, educational, or not-for-profit purposes provided that:

- a full bibliographic reference is made to the original source
- a [link](#) is made to the metadata record in DRO
- the full-text is not changed in any way

The full-text must not be sold in any format or medium without the formal permission of the copyright holders.

Please consult the [full DRO policy](#) for further details.

---



---

Shifting Networks and Community Identity at Tell Tayinat in the Iron I (ca. 12th to Mid 10th Century B.C.E.)

Author(s): Lynn Welton, Timothy Harrison, Stephen Batiuk, Elif Ünlü, Brian Janeway, Doğa Karakaya, David Lipovitch, David Lumb and James Roames

Source: *American Journal of Archaeology*, Vol. 123, No. 2 (April 2019), pp. 291-333

Published by: Archaeological Institute of America

Stable URL: <https://www.jstor.org/stable/10.3764/aja.123.2.0291>

---

JSTOR is a not-for-profit service that helps scholars, researchers, and students discover, use, and build upon a wide range of content in a trusted digital archive. We use information technology and tools to increase productivity and facilitate new forms of scholarship. For more information about JSTOR, please contact [support@jstor.org](mailto:support@jstor.org).

Your use of the JSTOR archive indicates your acceptance of the Terms & Conditions of Use, available at <https://about.jstor.org/terms>



Archaeological Institute of America is collaborating with JSTOR to digitize, preserve and extend access to *American Journal of Archaeology*

JSTOR

# Shifting Networks and Community Identity at Tell Tayinat in the Iron I (ca. 12th to Mid 10th Century B.C.E.)

LYNN WELTON, TIMOTHY HARRISON, STEPHEN BATIUK, ELIF ÜNLÜ, BRIAN JANEWAY, DOĞA KARAKAYA, DAVID LIPOVITCH, DAVID LUMB, AND JAMES ROAMES

*Open Access on AJA Online*

*Includes Supplementary Content on AJA Online*

The end of the 13th and beginning of the 12th centuries B.C.E. witnessed the demise of the great territorial states of the Bronze Age and, with them, the collapse of the extensive interregional trade networks that fueled their wealth and power. The period that follows has historically been characterized as an era of cultural devolution marked by profound social and political disruption. This report presents the preliminary results of the Tayinat Archaeological Project (TAP) investigations of Iron I (ca. 12th to mid 10th century B.C.E.) contexts at Tell Tayinat, which would emerge from this putative Dark Age as Kunulua, royal capital of the Neo-Hittite kingdom of Palastin/Patina/Unqi. In contrast to the prevailing view, the results of the TAP investigations at Early Iron Age Tayinat reveal an affluent community actively interacting with a wide spectrum of regions throughout the eastern Mediterranean. The evidence from Tayinat also highlights the distinctively local, regional character of its cultural development and the need for a more nuanced treatment of the considerable regional variability evident in the eastern Mediterranean during this formative period, a treatment that recognizes the diversity of relational networks, communities, and cultural identities being forged in the generation of a new social and economic order.<sup>1</sup>

## INTRODUCTION

The factors contributing to the epochal collapse and disappearance of the territorial states that dominated the political culture of the Late Bronze Age eastern Mediterranean at the end of the 13th century B.C.E., and with them the extensive interregional networks of trade and cultural dissemination

---

<sup>1</sup> The Tayinat Archaeological Project's Early Iron Age excavations have been supported by research grants from the Social Sciences and Humanities Research Council of Canada (SSHRCC), the Institute for Aegean Prehistory (INSTAP), and the University of Toronto, for which we are deeply grateful. We wish also to thank the Directorate of Cultural Heritage and Museums of Turkey, which has graciously awarded the research permits necessary to conduct each of our excavation seasons, the ministry representatives who have supported our fieldwork each season, the directors and staff of the Antakya Museum, and the Tayinat landowners, in particular the Kuseyri family, who have generously permitted us to work on their land. The ceramic analysis section of this paper was partially funded by Boğaziçi University Scientific Research Fund no. 13161. An online appendix can be found under this article's abstract on AJA Online ([www.ajaonline.org](http://www.ajaonline.org)).

that produced the cosmopolitan culture for which this age is known, continue to generate considerable scholarly interest. The ensuing so-called Dark Age, widely perceived as a period of cultural devolution marked by profound social and political disruption and widespread population dislocation, portrayed as the inevitable byproduct of the destructive forces that brought the preceding era to a close, draws similar investigative enthusiasm. Yet, despite this sustained attention, the complex and multivariate dynamics of this profoundly transformative period remain elusive and poorly understood.

Knapp and Manning, in a recent synthesis published in this journal,<sup>2</sup> highlight the persistent ambiguity of the evidence, both documentary and archaeological, that has proliferated with this intensified scholarly attention, and they emphasize the considerable regional variability evident in this record. They caution against the temptation to invoke uniform explanatory frameworks, the quest for a grand, conclusive solution that might explain the diverse array of evidence, and instead argue for a nuanced treatment contextualized by the myriad local environments and microregions that comprise the highly varied eastern Mediterranean landscape and anchored to a robust absolute chronology calibrated ideally to at least a decadal resolution. We agree that the development of such local histories will be crucial to any successful effort to achieve a deeper and more meaningful understanding of this pivotal moment in the history of human civilization. Furthermore, we share the view that the end of the Bronze Age and transition to the Iron Age is more productively conceptualized as a formative era that witnessed the forging of new relational networks (social, economic, and political), communities, and cultural identities, part of the “birth pangs of a new social and economic order,”<sup>3</sup> rather than as one defined primarily by collapse and cultural devolution.

This report seeks to contribute to this effort through a presentation of the preliminary results of the investigations by the Tayinat Archaeological Project (TAP) of contexts dating to this formative period, specifically the 12th to the mid 10th centuries B.C.E., at the site of

Tell Tayinat, located in the Amuq Plain of southeastern Turkey (fig. 1[13]).

The north Orontes Valley, and particularly the Amuq Plain, forms a discrete geographical unit with a rich historical and cultural record. The urban regeneration that characterizes the Iron Age was closely associated with the resettlement of Tell Tayinat, which had been abandoned for approximately 800 years, corresponding with the ascendancy of neighboring Tell Atchana (ancient Alalakh; see fig. 1[14]) and the kingdom of Mukiš during the Middle and Late Bronze Ages. During the Iron I period, Tell Tayinat transformed from a relatively small settlement into the royal capital of an Iron Age kingdom known at various times as Palastin/Walastin, Patina, and Unqi. Given its strategic location at the intersection of several important communication corridors, the Amuq Plain formed a unique nexus of broader regional cultural influences. The Amuq Plain thus represents an ideal place to study the competing social and ethnic influences that characterized Early Iron Age society in southeastern Anatolia and the northern Levant and to examine how these shifting identities and social networks contributed to the regeneration of local communities and ultimately to the emergence of the Syro-Anatolian states of the later Iron Age.

#### HISTORICAL CONTEXT

The prevailing view of the Early Iron Age has been that it constituted a clear cultural and political break from the preceding period. Recently, however, scholars have increasingly pointed to evidence of political and cultural continuity in southeast Anatolia and northwest Syria, particularly the evidence for continued Hittite political influence in the region.<sup>4</sup> In the mid 14th century B.C.E., the military campaigns of Suppiluliuma I in the southeast resulted in the decline of Mitanni and the subjugation of the kingdoms of western Syria, including Mukiš, Niye, and Nuhašše. Following these successes, Suppiluliuma implemented a series of unprecedented political changes designed to consolidate control over these newly conquered regions. This included appointing two of his sons as viceroys at two of the key strategic centers in the region. Telepinu became king and “Great Priest” at the important cult center of Aleppo (see fig. 1[19]), while Piyassili (later

<sup>2</sup> Knapp and Manning 2016.

<sup>3</sup> Broodbank 2013, 468; see also Voskos and Knapp 2008, 676–79; Knapp and Manning 2016, 99–100, 137–38; Murray 2017, 16–18.

<sup>4</sup> For more detail, see Hawkins 2002, 2009; Harrison 2009a, 2013; Weeden 2013; Younger 2016, 113–47.

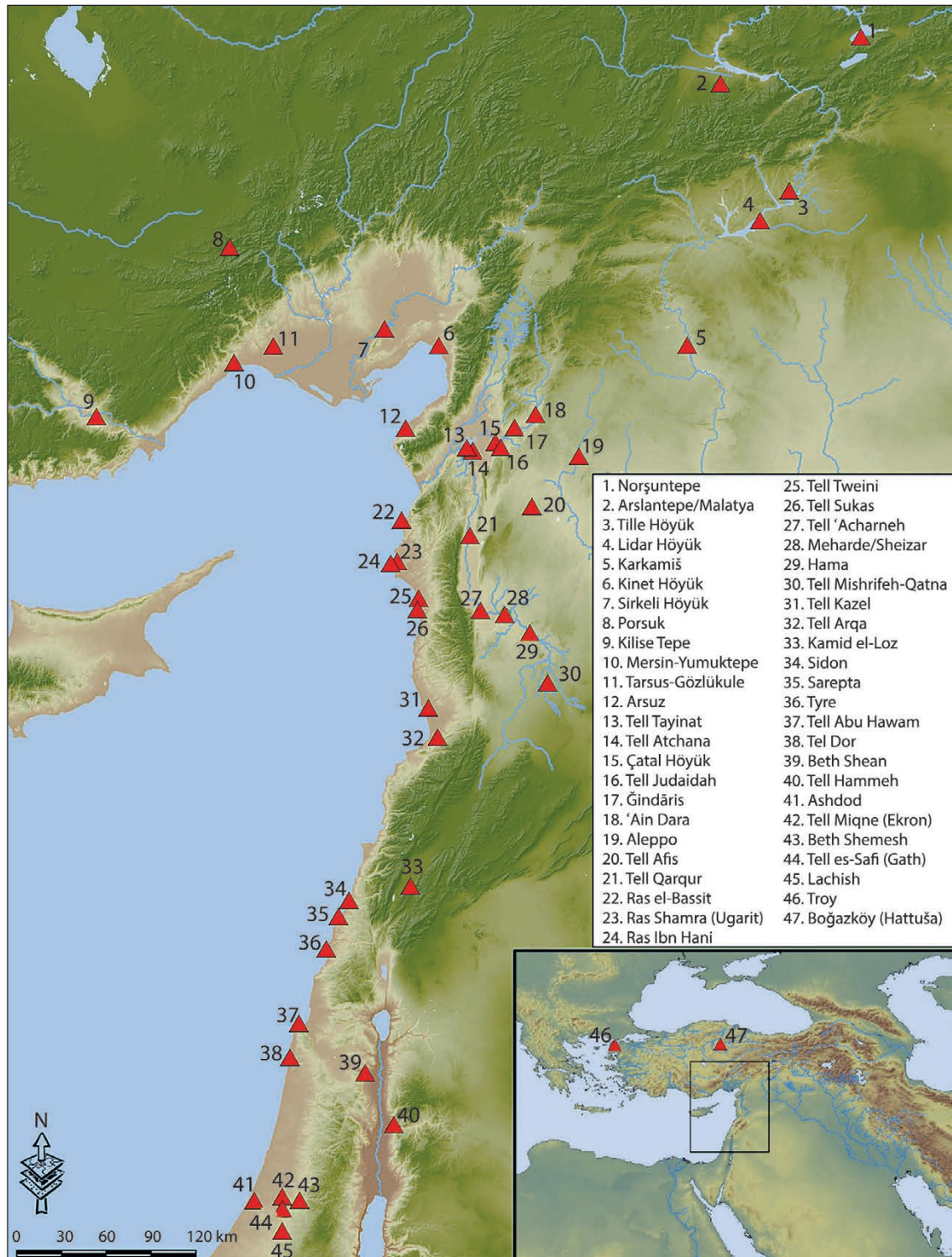

FIG. 1. Map of the Amuq Plain showing the location of Tell Tayinat and other principal settlements mentioned in the text (graphic by S. Batiuk).

Šarri-Kušuh) was appointed ruler at Karkamiš (see fig. 1[5]).<sup>5</sup> The two brothers appear to have maintained separate duties, with Aleppo the focus of religious and legal influence, and Karkamiš retaining political control over the region. The imposition of direct Hittite control represented a strategic move to stabilize the region and create a political buffer against the growing threats of Egypt and Assyria.

New epigraphic discoveries and reanalyses of previously discovered texts have provided evidence for the continuity of local lineages, in particular at Karkamiš, that survived the collapse of the central administration at Hattuša (see fig. 1[47]).<sup>6</sup> This evidence includes two seal impressions from Lidar Höyük (see fig. 1[4]) bearing the name Kuzi-Tešub, third in the line of Šarri-Kušuh and a contemporary of Suppiluliuma II, the final Hittite ruler.<sup>7</sup> The same Kuzi-Tešub appears to be mentioned in the genealogies of two kings of Malatya (ancient Melid; see fig. 1[2]), where he is referred to as “Great King” and “Hero of Karkamiš.” The fact that Kuzi-Tešub uses the title “Great King,” previously reserved for the ruling dynasty at Hattuša, suggests that his rule survived the collapse of the Hattuša dynasty.<sup>8</sup>

The discovery of the Temple of the Storm God on the Aleppo Citadel has introduced important new historical information for this period.<sup>9</sup> The excavations have produced two Hieroglyphic Luwian inscriptions, tentatively dated to the 11th century B.C.E.<sup>10</sup> These inscriptions contain autobiographical statements attributed to Taita, “Hero and King of Palastin,”<sup>11</sup> possibly the same ruler known from inscriptions at Meharde and Sheizar (see fig. 1[28]), located near Qal’at al-Mudiq northwest of Hama (see fig. 1[29]), although these latter inscriptions identify his kingdom as “Walastin.”<sup>12</sup> Reference to Walastin also occurs on two fragmentary Hieroglyphic Luwian inscriptions from Tell Tayinat<sup>13</sup> and on the recently

published Arsuz Stelae.<sup>14</sup> Together, these inscriptions imply the existence of an Early Iron Age kingdom known as Walastin/Palastin, centered in the Amuq Plain, encompassing an area that included Aleppo to the east, and extending southward in the Orontes Valley as far as Hama, with its capital located at Tell Tayinat.<sup>15</sup> Notably, this territory is similar in extent to the combined areas of the Late Bronze Age kingdoms of Mukiš, Niye, and Nuhašše, as well as Aleppo. Most recently, Hawkins has proposed the existence of two Taitas, the first dating to the 11th century (Taita I), and the second to the 10th century (Taita II), suggesting that the kingdom’s southward expansion might have occurred somewhat later.<sup>16</sup>

Despite the recent proliferation of historical evidence documenting continued Hittite political influence in the region, the Hittites were not the only political or ethnic group to have played a role in the development of the Early Iron Age culture of the northern Levant. There is also evidence of continued Hurrian cultural influence, reflecting the vestiges of earlier Mitanni control of the region,<sup>17</sup> and new and potentially intrusive Aegean influences that have long been linked to the “Sea Peoples.” These diverse cultural influences, meanwhile, operated within a framework of longstanding indigenous cultural development extending back to the Early Bronze Age.

Early studies of the Iron I<sup>18</sup> material culture of the Amuq have tended to emphasize its Aegean features, particularly in ceramic and textile production.<sup>19</sup> As a result, a disconnect has emerged between, on the one

<sup>5</sup> Bryce 1992, 1998.

<sup>6</sup> Hawkins 1988, 1995, 2002; Weeden 2013.

<sup>7</sup> Sürenhagen 1986; Güterbock 1992; Bryce 1998.

<sup>8</sup> Hawkins 1988, 1995, 2002.

<sup>9</sup> Kohlmeyer 2000, 2011; Gonnella et al. 2005; Hawkins 2011; Weeden 2013.

<sup>10</sup> Hawkins 2009, 2011; Weeden 2013.

<sup>11</sup> Previously read as Padasatini/Wadasatini; for changes in sign readings, see Rieken 2010; Rieken and Yakubovich 2010; for li- vs. la-, see Weeden 2015.

<sup>12</sup> Hawkins 1979; 2000, 415–19; 2011.

<sup>13</sup> Tayinat Inscription 1, dated on paleographic grounds to ca. 10th–early 9th century, and a newly discovered fragment;

Hawkins 2000, 365–67; Weeden 2013, 12; 2015.

<sup>14</sup> Hawkins 2011, 51; Dinçol et al. 2015. Paleography suggests a 10th-century date (Weeden 2013, 12–13).

<sup>15</sup> Harrison 2009b, 2013; Hawkins 2009; see Weeden 2013, table 2 for a tentative historical reconstruction.

<sup>16</sup> Hawkins 2011, 51; Weeden 2013.

<sup>17</sup> von Dassow 2008.

<sup>18</sup> Comparative archaeological chronology in the northern Levant is complicated by the use of varying chronological terminologies. In this report, we follow the Levantine chronological framework proposed by Mazzoni (2000): Iron IA (ca. 1200/1190–1100 B.C.E.), Iron IB (ca. 1100–1000 B.C.E.), and Iron IC (ca. 1000–900 B.C.E.). Thus, the Iron I, as used here, is roughly contemporary to Late Cypriot (LC) IIIA–IIIB, Aegean Late Helladic (LH) IIIC through Protogeometric, and southeastern Anatolian Late Bronze (LB) IIB and Early Iron Age (Gates 2011; Steel 2013).

<sup>19</sup> Swift 1958; Janeway 2008, 2011, 2017; Harrison 2009a, 2010.

hand, the growing historical record, based almost exclusively on fragmentary Hieroglyphic Luwian inscriptions, which highlight ancestral connections with Late Bronze Age Hittite political institutions, and, on the other hand, the evidence for discontinuity reflected by intrusive Aegeanizing cultural elements preserved in the archaeological record.<sup>20</sup> However, as we will see, the archaeological evidence from Tell Tayinat presents a considerably more complex reality, comprised of evidence for both cultural continuity and discontinuity. Recent syntheses have also begun to note historical evidence for Aegean influence in the region, most notably the recent suggestion that “Palastin” should be linked to the ethnonym of the Sea Peoples group identified as the *Peleset* in the Medinet Habu reliefs, generally accepted as the forebears of the biblical Philistines.<sup>21</sup>

The role of the Sea Peoples in the formation of Early Iron Age society has been studied in much greater detail for Cyprus and the southern Levant than it has in the northern Levant.<sup>22</sup> In Cyprus and the southern Levant, the so-called Philistine phenomenon has been variously interpreted as resulting from elite emulation, cultural diffusion, and active hybridization,<sup>23</sup> or, more commonly, as the product of various migration processes.<sup>24</sup> The role of the northern Levant in these discussions has only recently begun to draw more focused attention. Recent syntheses of the available evidence have varied significantly, with some emphasizing continuity and indigenous development and others arguing for sudden change and the influx of new populations, or a combination of both.<sup>25</sup> Singer recently criticized

the tendency of scholars working in the northern Levant, in contrast to their counterparts in the southern Levant, to emphasize evidence for gradual local indigenous development at the expense of evidence for intrusive disruption and a break with the Late Bronze Age.<sup>26</sup> However, these diverging perspectives need not be considered contradictory; rather, they highlight the different developmental trajectories experienced locally in the varying regions of the eastern Mediterranean during the 12th–11th centuries and the need for regionally sensitive discussions of cultural development.<sup>27</sup> The impact of the so-called Sea Peoples phenomenon need not—indeed should not—be viewed monolithically throughout the eastern Mediterranean. That the Iron I remains at Tell Tayinat have often been cited in this debate underlines its pivotal role in reconstructing the complex development of Early Iron Age northern Levantine society.<sup>28</sup>

#### PREVIOUS INVESTIGATIONS

Tell Tayinat was the focus of large-scale excavations by the Oriental Institute of the University of Chicago as part of its Syrian-Hittite Expedition, which undertook investigations in the Amuq Plain between 1935 and 1938. Excavations at Tell Tayinat focused primarily on wide horizontal exposures of levels dating to the Iron II–III (ca. 900–600 B.C.E.; Amuq Phase O) in the West Central Area of the upper mound and secondarily on several smaller soundings conducted in other areas.<sup>29</sup> These excavations produced only “traces” of the Iron I (ca. 1200–900 B.C.E.; Amuq Phase N), primarily in the form of pottery, although these traces were encountered in many of the trenches excavated on the site’s upper mound.<sup>30</sup>

Very little of the Amuq Phase N material encountered by the Syrian-Hittite Expedition has been published. A published description of the Iron Age architecture included Phase N remains at Çatal Höyük (see fig. 1[15]) and Tell Judaidah (see fig. 1[16]).<sup>31</sup> More recently, there has been a renewed effort to publish fully the results of the Syrian-Hittite Expedition’s

<sup>20</sup> As noted by Singer (2012, 466), who postulated a break in settlement between the earliest Iron Age settlement at Tayinat and the later Neo-Hittite kingdom.

<sup>21</sup> Hawkins 2009, 2011; Yasur-Landau 2010; Strobel 2011; but see Schneider 2011, 571–72; Singer 2012, 467; Younger 2016, 127–35, for arguments against the equation of these names.

<sup>22</sup> The literature is vast, but see Dothan 1982; Karageorghis 1990; Dothan and Dothan 1992; Oren 2000; Iacovou 2008; Voskos and Knapp 2008; Yasur-Landau 2010; Killebrew and Lehmann 2013; and Stern 2013, for the primary bibliography.

<sup>23</sup> Sherratt 1998, 2003; Voskos and Knapp 2008; Middleton 2015.

<sup>24</sup> Among others, Dothan 1982; Stager 1995; Yasur-Landau 2010.

<sup>25</sup> Jean 2003; Müller 2003; du Piéd 2008, 2011; Gates 2010; Venturi 2010, 2011, 2013; Badre 2011; Vansteenhuyse and Bretschneider 2011; Pucci 2013; Yalçın 2013.

<sup>26</sup> Singer 2012, 454 n. 13.

<sup>27</sup> Gilboa 2008; Gates 2010, 65.

<sup>28</sup> Yasur-Landau 2010, 161–63; du Piéd 2011; Karageorghis 2011, 23; Singer 2012, 464–68; Sherratt 2013, 625–27; Weeden 2013, 11; Galil 2014, 79–80; Younger 2016, 131–35.

<sup>29</sup> Braidwood and Braidwood 1960; Haines 1971.

<sup>30</sup> Swift 1958, 6, 10.

<sup>31</sup> Haines 1971.

excavations, including a reexamination of the Phase N Iron I material, particularly from Çatal Höyük.<sup>32</sup> Unfortunately, none of the Iron I material found at Tayinat was recovered from secure contexts. Thus, while an Iron I presence at Tayinat has long been recognized, it has been neither well understood nor dated chronologically with any precision.

The earliest stratified Iron Age remains excavated at Tayinat by the Syrian-Hittite Expedition consisted of two buildings (Buildings XIII and XIV; fig. 2).<sup>33</sup> Only limited exposures of these structures were achieved beneath the floors of the rooms of later monumental buildings dating to the Iron II (Building Period 2). Both buildings were assigned to Building Period 1 by the Chicago excavators and likely date to the Iron I/II transition or sometime in the late 10th–early 9th centuries B.C.E.

#### TAYINAT ARCHAEOLOGICAL PROJECT INVESTIGATIONS

The Tayinat Archaeological Project was conceived within the framework of the Amuq Valley Regional Project (AVRP), which has systematically documented the archaeology of the Amuq Plain since 1995. Following preliminary field seasons in 1999–2002 that were devoted to surveying and mapping the site,<sup>34</sup> targeted excavations were initiated in 2004. These investigations were expanded to full-scale excavations in 2005 and have continued on an annual basis since.<sup>35</sup>

Tell Tayinat forms a large, low-lying mound 1.5 km east of the town of Demirköprü, on the north shoulder of the modern Antakya–Reyhanlı road that runs along the southern edge of the Amuq Plain. The mound sits within the flood plain of the Orontes River, on its northern bend just beyond the point where the river enters the Amuq Plain before working its way westward toward Antakya (ancient Antioch) and the Mediterranean Sea (see fig. 1). A topographic survey, conducted in 2001, revealed that the site is comprised of a principal upper mound (ca. 20 ha in size) and a sprawling lower mound now hidden by the alluvium of the Orontes floodplain. This lower mound extends from the upper mound toward the north, east, and

southeast, visible in CORONA satellite imagery as a clearly discernable shadow (see fig. 2). Sherd density distributions produced from surface survey confirm the spatial parameters of the lower settlement and suggest a site size encompassing approximately 35–40 ha.<sup>36</sup>

In contrast to the Syrian-Hittite Expedition's investigations, TAP's excavations have encountered Iron I remains in all areas that have reached pre-Iron II levels. When taken together, the composite results of both expeditions indicate a minimum site size of 10–12 ha, and possibly as large as 20 ha, for the Iron I settlement. Tayinat is thus one of the largest settlements in the eastern Mediterranean during the 12th–11th centuries B.C.E. The most substantive Iron I exposures have been achieved in Fields 1 and 4 (see fig. 2). This report will focus on the results of the TAP investigations in these two fields.

#### FIELD 1 INVESTIGATIONS

Field 1 is centrally located on the upper mound, at the southern edge of the Syrian-Hittite Expedition's West Central Area, and it links the renewed TAP investigations with the work of the earlier expedition (see fig. 2). The Field 1 excavations were initiated as a two-week exploratory sounding in 2004 and expanded in 2005 to the current four 10 x 10 m squares (G4.55, G4.56, G4.65, and G4.66; fig. 3). To date, the excavations have delineated nine superimposed Field Phases (FP), with the main archaeological sequence dating to the 12th–early 10th centuries B.C.E., or the Iron I period (FPs 6–3), and the late third millennium B.C.E., or Early Bronze (EB) IVB (FPs 9–7).

#### *Architecture and Stratigraphy*

The earliest Iron Age settlement remains, represented by three subphases of FP6 (FP6c, b, and a, in chronological order; see fig. 3), lie directly atop levels dating to the late third millennium B.C.E. (Amuq Phase J).<sup>37</sup> FP6 preserves several large storage silos (e.g., G4.56:153, 159, 164, 176, 237), some of which were constructed with a lining of mudbrick (e.g., G4.56:279, 288; fig. 4). Numerous smaller pits are interspersed between the large silos; a few of these contained concentrations of nonperforated, cylindrical

<sup>32</sup> Pucci 2010, 2013, (forthcoming).

<sup>33</sup> Haines 1971, 38–40; Harrison 2010, 2013.

<sup>34</sup> Batiuk et al. 2005.

<sup>35</sup> TAP reports are published annually in *Kazı Sonuçları Toplantısı*.

<sup>36</sup> Batiuk et al. 2005; Osborne 2017; Osborne and Karacic 2017.

<sup>37</sup> Welton et al. 2011; Welton 2014.



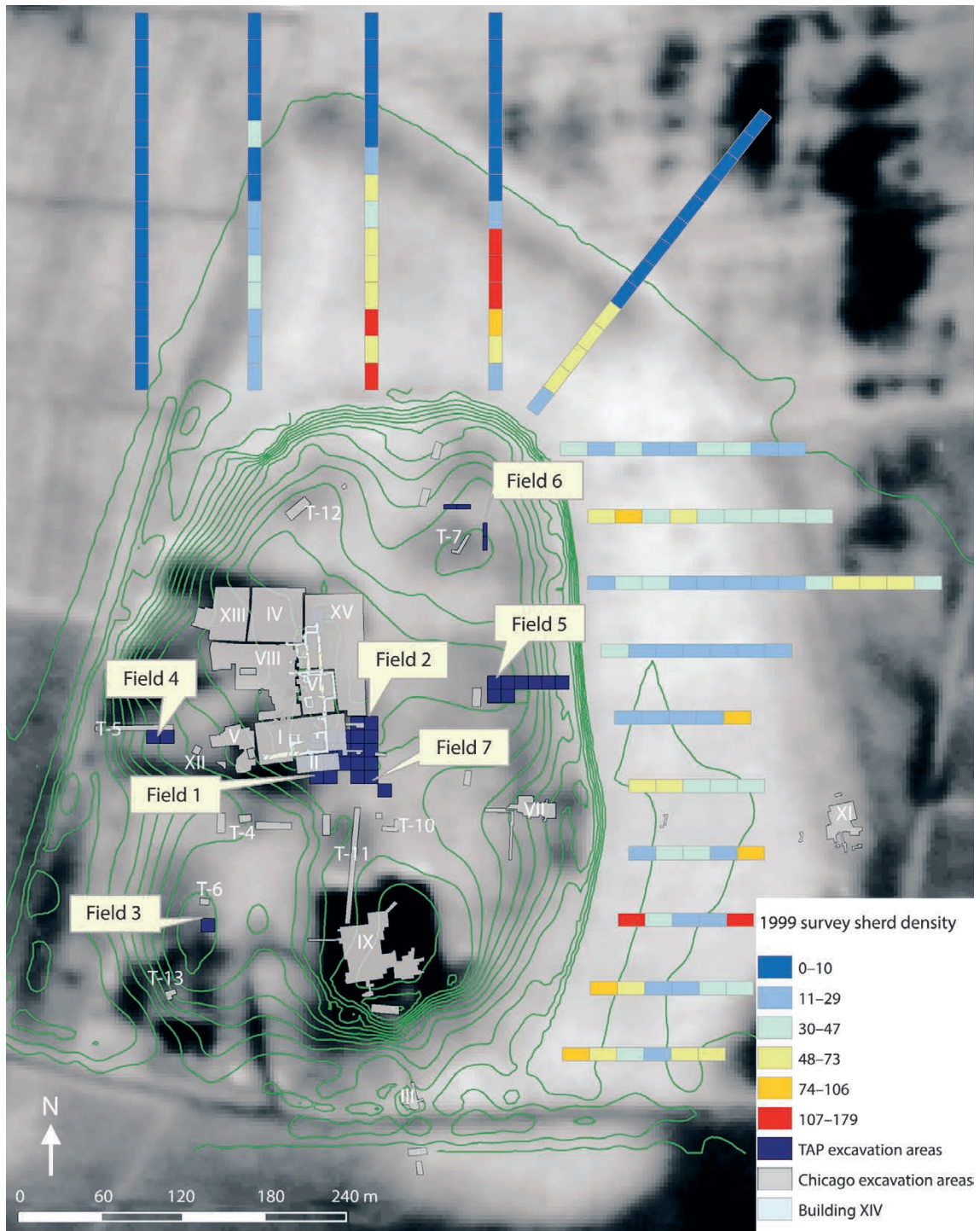

FIG. 2. Topographic map of Tell Tayinat overlaid on a CORONA satellite image of the site, showing the principal excavation areas and a density distribution of surface pottery in the lower settlement, represented by the light-colored area to the north and east of the site (graphic by S. Batiuk).

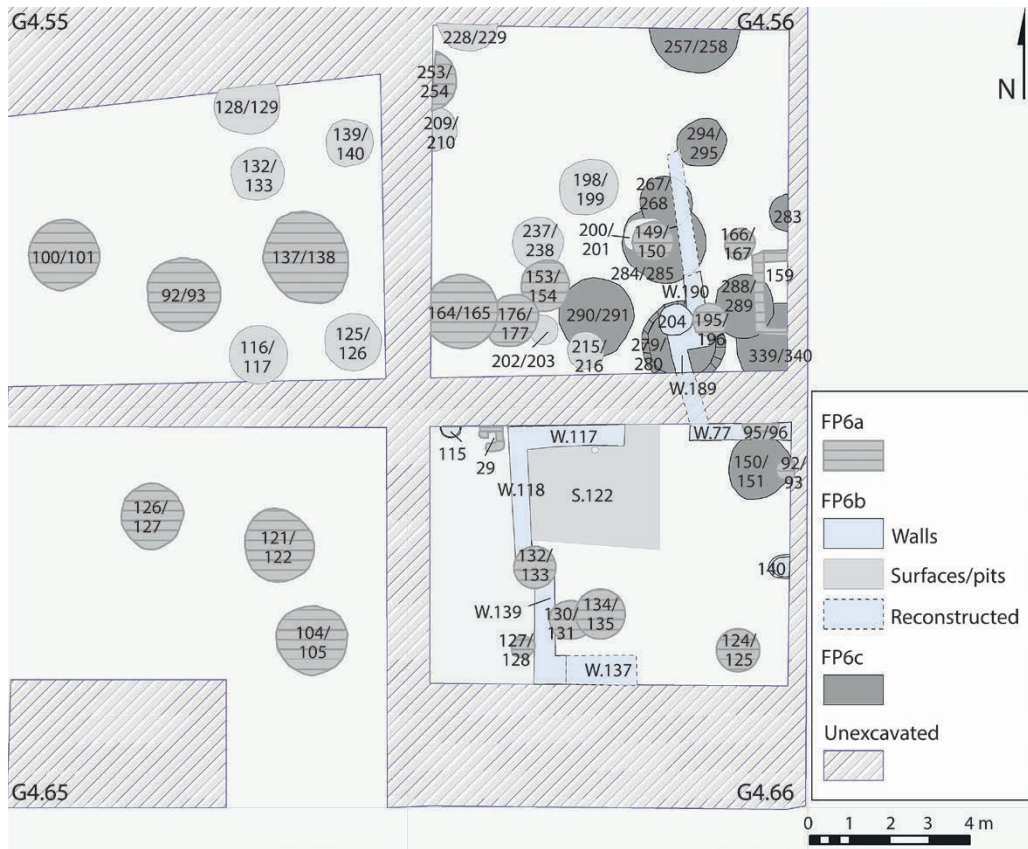

FIG. 3. Plan of Field Phase 6 architecture and other loci in Field 1 (graphic by L. Welton).



FIG. 4. Mudbrick lining visible in storage silo G4.56:279; arrow points north (D. Lumb).

clay loomweights and other artifacts associated with textile production (e.g., G4.56:167, 196; fig. 5; see further below).

In addition, architecture dating to FP6b includes two walls that join in a dogleg pattern in the southeast corner of square G4.56 (G4.56:189, 190; see figs. 3, 6). A small, circular, pyrotechnic installation (see figs. 3, G4.56:204; 6), likely a *tannour*-type oven, was uncovered in the corner formed by these two walls. These walls likely relate to walls uncovered to the south, in square G4.66, which form the northwestern portion of a single room (G4.66:77, 117, 118, 137, 139). Inside this structure, an ephemeral beaten-earth surface with flat-lying sherds was identified (G4.66:122). Two additional possible *tannour*-type ovens at the northwest and east sides of square G4.66 were associated with this architecture (G4.66:115, 140; fig. 7, top). A further example occurs in the eastern section of G4.56 (G4.56:283, FP6c; see fig. 7, bottom), and discarded fragmentary remains of similar constructions have been found in refuse pits in the same area (G4.56:257, FP6c).

In the southern squares of Field 1 (G4.65 and G4.66), the foundations of the Iron II temple (Building II; FP2a/b)<sup>38</sup> cut directly down to the level of FP6, leaving no remains of later Iron I phases. To the south, an Iron II passageway or street (FP2d, pre-Temple II)<sup>39</sup> cut through the Iron I remains and directly into Early Bronze Age levels, leaving little Iron I material intact in the southern parts of these squares. However, in the eastern portion of squares G4.56 and G4.66, FP6 deposits reached greater depths than identified to the west and represent the earliest Iron I remains (FP6c) encountered to date; this phase was not preserved in the western squares (G4.55 and G4.65) of Field 1.

Because of the disturbance from Iron II construction activity, remains dating to FPs 5 and later were encountered primarily in the northern two squares, G4.55 and G4.56 (figs. 8–10). Architecture in FP5b includes a mudbrick wall constructed along the northern edge of the excavation trench (G4.55:27, 29 = G4.56:33; see fig. 8). Several other poorly preserved wall segments in square G4.55 (G4.55:62–65, 77, 83, 99) show a similar orientation and are also attributed to FP5b, as are wall fragments found in G4.56 (G4.56:120, 132). These walls were associated with



FIG. 5. Loomweights in pit G4.56:196; arrow points north (D. Lumb).

an accumulation of superimposed beaten-earth surfaces (G4.55:20, 75, 82, 85, 86, 96; G4.56:121). Well-constructed storage bins and silos also date to this phase (G4.55:23/24; G4.56:111/112; the latter had a dividing wall separating it into two halves; see fig. 9). Remains from FP5a are even more ephemeral and consist of secondary surfaces associated with reuse of the FP5b structures (G4.55:17, 75, 78) and additional silos and refuse pits.

FP5 was sealed by a more substantial construction layer (FP4), which included the best-preserved architectural remains from the Iron I sequence (see fig. 10). In particular, a well-preserved rectilinear structure (G4.56:23, 66–68, 31/76; see figs. 10, 11) was excavated in the western part of G4.56. The walls formed a single small room, measuring approximately 3.5 x 2 m in size. Several other significant, although fragmentary, walls also date to this phase (G4.55:15, G4.56:91 = G4.66:145; G4.56:92/96, 110, 114). All of these walls display a similar construction technique. While the earlier phases did not make significant use of foundation trenches, in FP4, deep, straight-sided foundation trenches were excavated into the surrounding soil matrix and were packed directly with mudbricks. Similar foundation trenches, although generally on a larger scale, are observed in later monumental constructions at Tayinat such as Building XIV and Building II, and at Tell Atchana (Alalakh) in the Level II “Hittite Fortress.”<sup>40</sup> These walls were constructed entirely of mudbrick, with no stone foundations; the absence of

<sup>38</sup> Haines 1971, 53–5, 64–6, pl. 103.

<sup>39</sup> See detailed description in Osborne et al. (forthcoming).

<sup>40</sup> Woolley 1955, 167; Harrison 2010, 90; Akar 2013, 43.



FIG. 6. FP6b architecture (walls G4.56:189, 190; installation G4.56:204 at center left) in square G4.56; arrow points north (D. Lumb).

stone foundations is a distinctive construction feature seen throughout the occupational sequence at Tayinat.

FP3, the final phase in the Field 1 Iron I sequence, is represented primarily by substantial pitting activity. This was best exemplified by two large ashy pits in the western part of square G4.55 (G4.55:18/19, 36/37; see fig. 10), one of which (G4.55:18/19) was sealed by a concave plastered installation (G4.55:16). No walls or other freestanding structures were assigned to this phase.

As noted above, the foundations of Building II cut deeply into these Early Iron Age remains, obliterating the remains of any intervening cultural strata. The superstructure and substructure associated with this building were assigned to FP2a/b.<sup>41</sup> The associated pottery contained quantities of Red Slip Burnished Ware and is dated to Iron II. Any later Iron I levels, dating to the Iron IC, that might have once existed in this area were completely destroyed by this later construction activity.

<sup>41</sup> Osborne et al. (forthcoming).

The remains of Building XIV, originally excavated by the University of Chicago in the 1930s, are situated in Field 2, immediately to the north of Field 1.<sup>42</sup> TAP investigations of this building have not encountered any intact floors or superstructure, preventing a direct determination of the date of its construction and use.<sup>43</sup> However, small islands of Iron I material are preserved between the deep foundation trenches of this building, the uppermost of which postdate the Iron I sequence in Field 1, and likely date to the mid 10th century B.C.E.

#### *The Ceramic Assemblage*

Previous publications discussing the Iron I remains from Tell Tayinat have emphasized the Aegeanizing aspects of the pottery from the site.<sup>44</sup> In particular,

<sup>42</sup> Osborne et al. (forthcoming).

<sup>43</sup> Harrison 2010, 90–1; 2013; see, however, Manning et al. (forthcoming) for a radiocarbon model-based approach to its date.

<sup>44</sup> Swift 1958; Janeway 2008, 2011, 2017; Harrison 2009a, 2010.



FIG. 7. *Tannour*-type ovens in Field 1: *top*, G4.66:115; arrow points north (E. Coate and D. Johnson); *bottom*, G4.56:283, containing a ceramic vessel; arrow points north (S. Batiuk).

Swift's work on ceramic material from the University of Chicago excavations suggested that painted wares (combining local features continuing from the Bronze Age with Mycenaean influences) formed 90–95% of the assemblage of Phase N.<sup>45</sup> However, equally or more common throughout the Iron I sequence are locally produced plain wares bearing no direct relationship to the Late Helladic IIIC tradition.<sup>46</sup>

*Plain Wares.* Iron I Plain Wares (fig. 12) at Tayinat are wheelmade and most frequently moderately coarse. Small amounts of chaff temper occur in most examples, visible both in cross-section and on the sherd surface.<sup>47</sup> Fabric color ranges from tan to pinkish-

buff, with large vessels generally displaying gray cores and smaller vessels usually fully oxidized. Plain Ware vessels typically have minimal surface treatment, usually restricted to simple smoothing of the surface. In FP6c, the bases of some plates and bowls show scraping marks (see fig. 12, nos. 1, 6, 13).

The most frequent Plain Ware forms include platters, small hemispherical bowls, larger deep bowls, and several jar or amphora forms. Platters vary widely in rim diameter, from approximately 18 cm to 45 cm, and display a variety of rim forms (see fig. 12, nos. 1–11). The earliest platters are generally smaller in diameter, with internally thickened rims (see fig. 12, nos. 1–4); stepped platters occur rarely in the earliest levels (FP6c; see fig. 12, no. 5). Large platter-bowls with inturned or thickened rims (see fig. 12, nos. 6, 7) also occur. There is a trend over time toward shallower bodies, larger diameters, simpler rounded or squared rim shapes (see fig. 12, nos. 8–11), and bases that evolve from rounded to ring base profiles. These changes herald the later Iron II platter tradition.<sup>48</sup>

The earliest forms demonstrate continuity with the Hittite Monochrome Ware (HMW) tradition of Late Bronze Age Anatolia, with parallels from highland central Anatolia<sup>49</sup> and particularly from the terminal phases of the Hittite Empire Period.<sup>50</sup> The forms represented at Tayinat also correspond closely with assemblages from Late Bronze Age levels at neighboring Tell Atchana (Alalakh) and Çatal Höyük, and from both Late Bronze and Iron Age levels at Tell Afis (see fig. 1[20]).<sup>51</sup> Similar forms also occur in Late Bronze–Iron Age transitional period assemblages of sites in neighboring regions, such as at Kilise Tepe (see fig. 1[9]), Porsuk (see fig. 1[8]), Mersin-Yumuktepe (see fig. 1[10]), Tarsus-Gözlükule (see fig. 1[11]), Sirkeli Höyük (see fig. 1[7]), and Kinet Höyük (see

Höyük (Pucci 2013, 98; [forthcoming], 135), and Tell Afis (Venturi 2010, 5–6; 2013, 235).

<sup>48</sup>Iwasaki et al. 2009; Osborne 2011; Soldi 2013; and associated bibliography therein.

<sup>49</sup>Müller-Karpe 1988, pls. 29–37; Parzinger and Sanz 1992, figs. 19I, 20J.

<sup>50</sup>Schoop 2003, figs. 3.1–4, 4.4–6.

<sup>51</sup>Tell Atchana (Alalakh): Woolley 1955, pl. 109:3b, 4b, 5, 6; Horowitz 2015, fig. 7.5:6, 7. Çatal Höyük: Pucci 2013, 92, figs. 2:1–12, 6:5, 7; (forthcoming), 135–36, fig. 43. Tell Afis: Venturi 2000, fig. 5.1–8; 2007, 247–48, figs. 48:1–14, 54:1, 2, 56:5–8, 59:1–8; 2013, fig. 7:3–11.

<sup>45</sup>Swift 1958, 64.

<sup>46</sup>Ünlü 2017.

<sup>47</sup>Chaff temper is also attested at Tarsus-Gözlükule (Goldman 1956, 203), Kinet Höyük (Gates 2006, 307; 2013a), Çatal

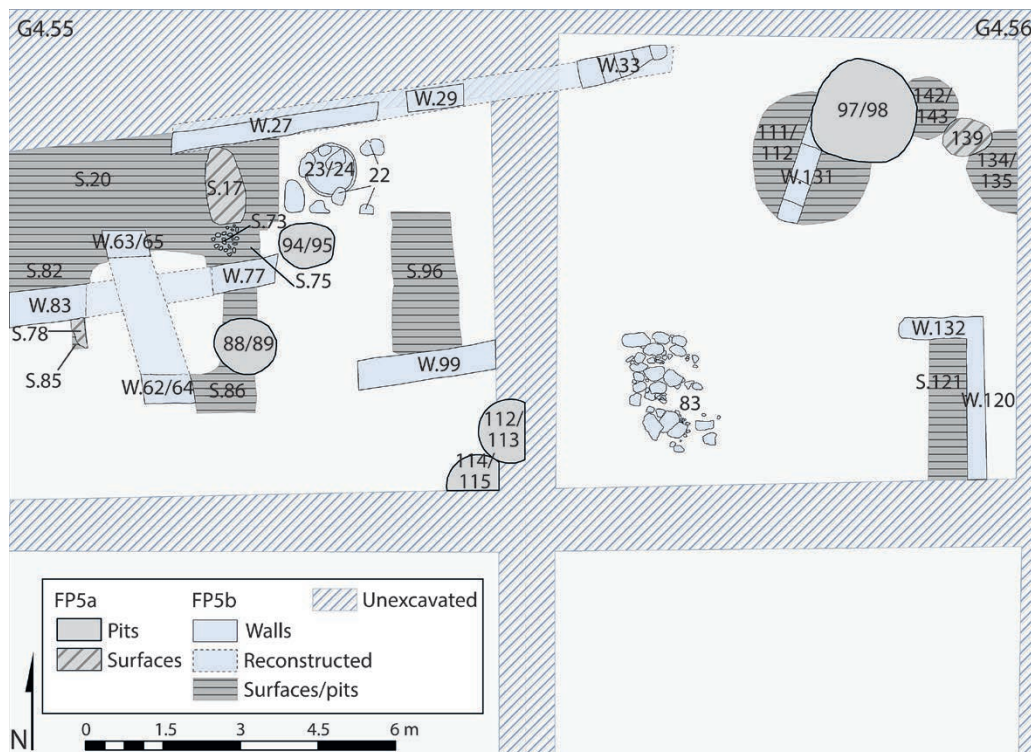

FIG. 8. Plan of Field Phase 5 architecture and other loci in Field 1 (graphic by L. Welton).

fig. 1[6]) in Cilicia, and at Arslantepe/Malatya, Tille Höyük (see fig. 1[3]), Norşuntepe (see fig. 1[1]), and Lidar Höyük in the Upper Euphrates region of south-eastern Turkey.<sup>52</sup>

Hemispherical bowls (see fig. 12, nos. 12–14) have rounded bases and simple upturned rims and have diameters of 16–20 cm; occasionally these forms have straight upper sections (see fig. 12, no. 15). Plain Ware bowls with distinct carinations also occur (see fig. 12, nos. 16, 17). Rounded hemispherical bowls occur at Tell Atchana (Alalakh) and Çatal Höyük, and

in the HMW tradition of highland central Anatolia, especially in the latest Hittite Empire period levels at Hattuša.<sup>53</sup> They are also common in neighboring regions, including Kilise Tepe, Porsuk, Norşuntepe,



FIG. 9. Storage silo G4.56:111/112 with dividing wall G4.56:131; arrow points north (S. Batiuk).

<sup>52</sup> Kilise Tepe, Levels III–II: Hansen and Postgate 2007, figs. 387, 388, 395; Bouthillier et al. 2014, figs. 46:c, d, 47:a. Porsuk, Level V: Dupré 1983, pls. 5–13. Mersin-Yumuktepe: Garstang 1953, 249, fig. 157.1–7; Sevin and Köroğlu 2004, figs. 4, 5. Tarsus-Gözlükule: Goldman 1956, fig. 384; Yalçın 2013, fig. 6. Sirkeli Höyük: Kozal 2013, fig. 2:9–11. Kinet Höyük: Gates 2001, figs. 2.1–8, 3.1–3, 5.1–5, 8; 2013a, fig. 5. Arslantepe/Malatya: Manuelli 2013, figs. 2, 5:1–5. Tille Höyük, Pre-Burnt Level: Summers 1993, fig. 43:4–11; 2013, fig. 10:1–3. Norşuntepe: Korbel 1985, pls. 1–4, 25, 37, 38, 64–7, 80–2, 110, 111. Lidar Höyük: Müller 1999, fig. 5.3.

<sup>53</sup> Tell Atchana (Alalakh): Woolley 1955, pl. 110:14, 15; Horowitz 2015, fig. 7.6:14. Çatal Höyük: Pucci (forthcoming), 135, fig. 43:1. Highland central Anatolia: Müller-Karpe 1988, pl. 37; Parzinger and Sanz 1992, fig. 19.I.1.3. Hattuša: Schoop 2003, fig. 3.5.

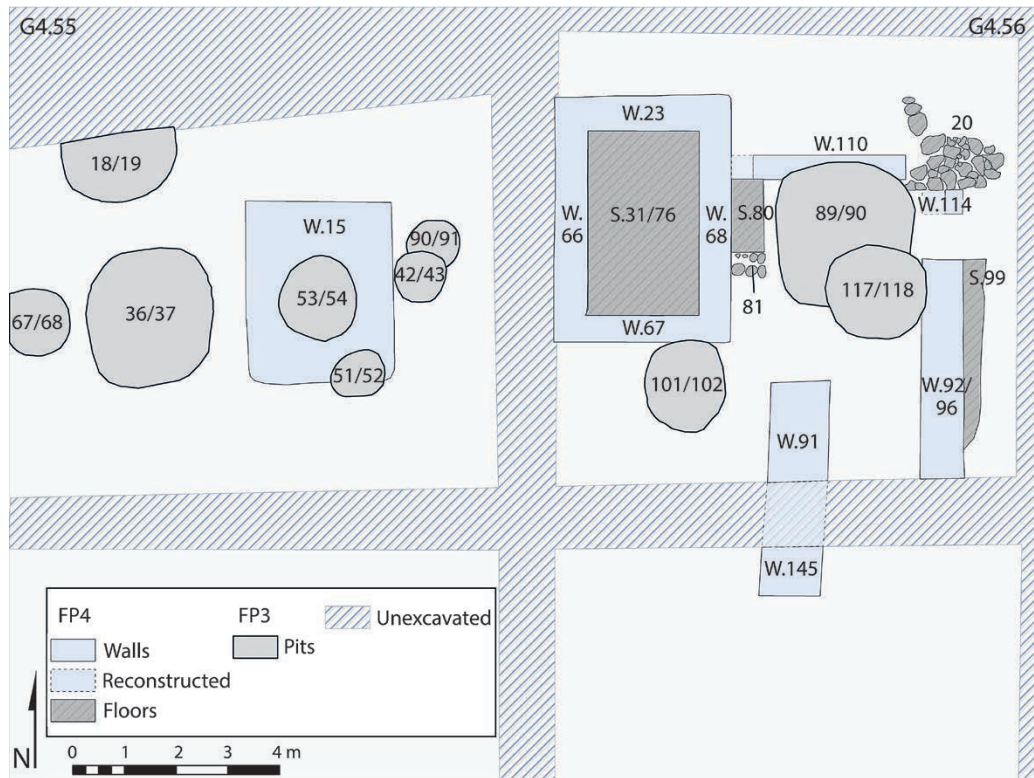

FIG. 10. Plan of Field Phase 4–3 architecture and other loci in Field 1 (graphic by L. Welton).



FIG. 11. Field Phase 4 mudbrick architecture in G4.56 (G4.56:23, 66–68; arrow points north; D. Lumb).

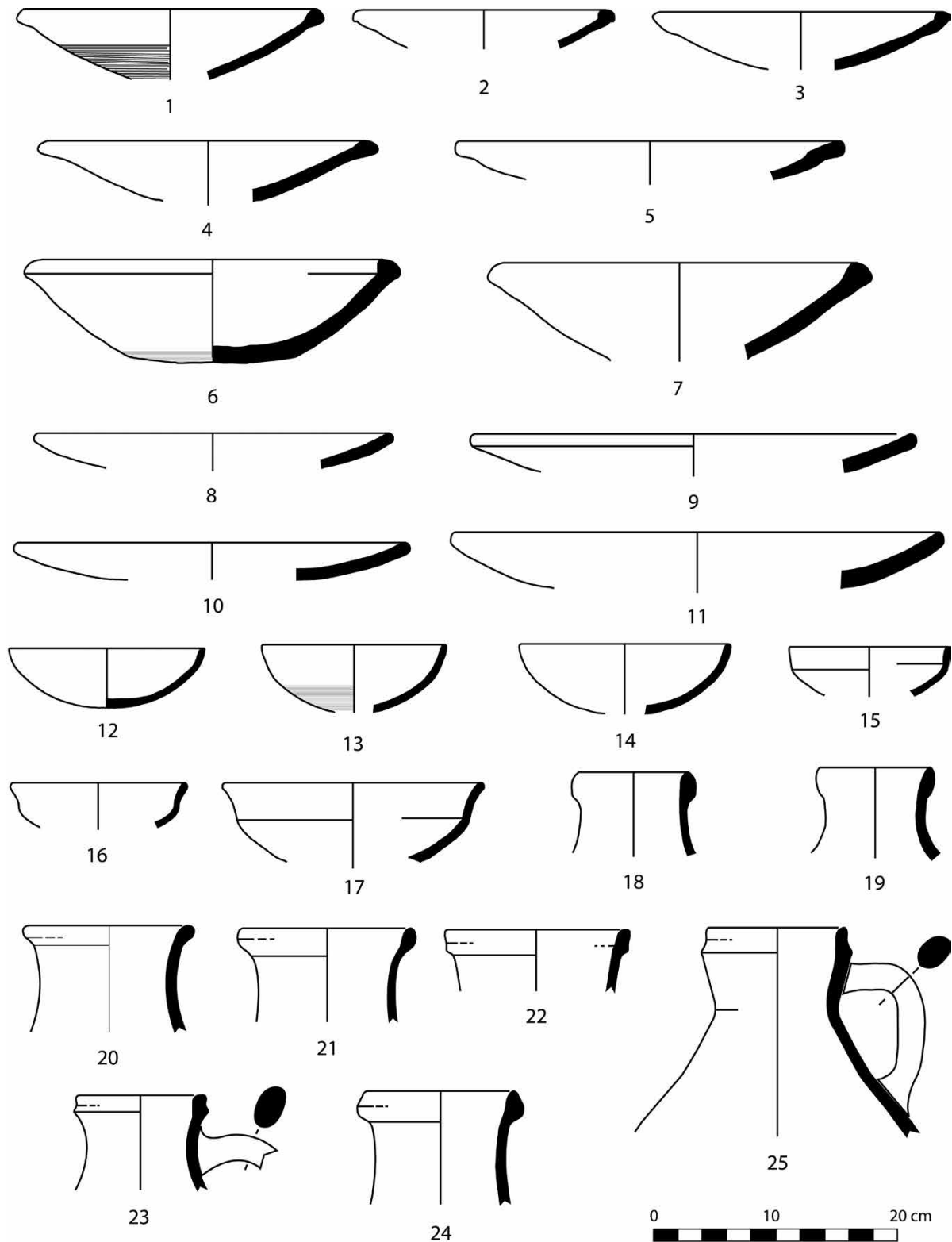

FIG. 12. Plain Ware: 1–11, platters; 12–17, bowls; 18–25, amphoras; FP6c: 1–3, 5–7, 12–17, 19; FP6b–c: 4; FP6b: 9, 10, 18, 20–2; FP6a: 8, 25; FPSb: 11; FPSa: 24; FP4: 23 (drawings by L. Welton).



Tarsus-Gözlükule, Tell Afis, and Kinet Höyük.<sup>54</sup> Carinated bowls are less common but are found at Tell Afis.<sup>55</sup>

In the early phases of the Iron I sequence, Plain Ware amphoras with narrow mouths and oval rims regularly occur (see fig. 12, nos. 18, 19). Later phases demonstrate a greater variety of rim types, with both rim and neck handles, and similarities to painted amphoras discussed further below (see fig. 12, nos. 20–5). Also represented are fusiform transport vessels (fig. 13). Plain Ware krater and pithos forms vary in size and shape and include kraters with square or rounded grooved rims, biconical kraters with upturned rims, and pithoi with a variety of rim forms (fig. 14). Some of these shapes fall within the range of forms typical of the HMW tradition,<sup>56</sup> but they are also well represented in Late Bronze and Late Bronze–Iron Age transitional period assemblages at other sites in the region, including Kilise Tepe, Mersin-Yumuktepe, Tarsus-Gözlükule, and Kinet Höyük in Cilicia, Arslantepe/Malatya and Lidar Höyük in southeastern Anatolia, and Tell Atchana (Alalakh), Tell Afis, and Ugarit (see fig. 1[23]) in the Levant.<sup>57</sup>

Plain Ware is the dominant ware type in FP6c, varying between 72% and 87% of the assemblage. It continues throughout the Iron I sequence but decreases as a proportion of the assemblage during FP6b–a, reaching its minimum frequencies in FP5. By FP3, Plain Ware again increases in frequency to form about 70% of the overall assemblage. The frequency of Plain Ware forms with close similarities to sites through-

out the Anatolian world in the earliest Iron I phases at Tayinat suggests that the regional HMW potting tradition continued even after the settlement shift had occurred between Atchana and Tayinat. The persistence of the HMW potting tradition into the 12th century, following the collapse of the Hittite political and administrative center at Hattuša, has also been reported at other sites in the region, including Kilise Tepe, Mersin-Yumuktepe, Tarsus-Gözlükule, Tille Höyük, Arslantepe/Malatya, Karkamiš, Norşuntepe, and Lidar Höyük.<sup>58</sup>

*Late Helladic IIIC–Style Wares.* Late Helladic (LH) IIIC–style pottery forms a second dominant potting tradition in Field 1 between FPs 6 and 3 (fig. 15). A wide spectrum of forms, motifs, and fabrics are represented in the assemblage, which is characterized by its nonstandardized production. Compared with Plain Wares, LH IIIC–style pottery tends to have finer fabrics, with few visible inclusions. Two fabric and paint color combinations predominate: red painted decorations on a pinkish fabric (RoP), made from an iron-rich clay, and black painted decorations on a buff or whitish fabric (BoW), composed of a more carbonaceous or marly clay.<sup>59</sup> In the earliest phases, the former is most common. In the latest levels, a pinkish iron-rich fabric with black painted decoration also appears in smaller numbers.

Only the most salient features of the assemblage will be described here, since more thorough descriptions have been presented elsewhere.<sup>60</sup> Shallow rounded bowls and deeper bell-shaped bowls, or skyphoi (FS 284/285),<sup>61</sup> are the most common vessel types (see fig. 15, nos. 1–15). Although deep bowls from Tayinat are variable in form, they are typically equipped with close-set horizontal handles, usually with a painted band along the handle, and a ring base. Short or sharp rims and/or stubby handles comprise traits that may represent local developments peculiar to the Amuq.<sup>62</sup>

<sup>54</sup> Kilise Tepe: Hansen and Postgate 2007, figs. 387.575, 578. Porsuk: Dupré 1983, pls. 4.2–5, 5.11–13. Norşuntepe: Korbel 1985, pls. 1, 4, 11, 24. Tarsus-Gözlükule: Goldman 1956, fig. 384.1113; Korbel 1987, pl. 11.477. Tell Afis: Venturi 2007, 249–50, figs. 48:18, 56:9, 59:10–11. Kinet Höyük: Gates 2013a, fig. 5; 2013b, figs. 6:1, 9:2.

<sup>55</sup> Venturi 2007, 250, fig. 59:14.

<sup>56</sup> Müller-Karpe 1988, pls. 3–6, Types K2, K20–23, T8–11; Parzinger and Sanz 1992, figs. 15.4.4.b, 15.4.6.b, 16.6.2.b.

<sup>57</sup> Kilise Tepe: Hansen and Postgate 2007, figs. 387.573, 389.649. Mersin-Yumuktepe: Sevin and Köroğlu 2004, fig. 7.3. Tarsus-Gözlükule: Goldman 1956, figs. 385.1191, 389–O. Kinet Höyük: Gates 2001, fig. 5.12–13; 2013a, figs. 6, 7; 2013b, figs. 8:1, 3, 5; 9:8–9. Arslantepe/Malatya: Manuelli 2013, fig. 4:2–4. Lidar Höyük: Müller 1999, fig. 5.7. Tell Atchana (Alalakh): Woolley 1955, pl. 111:39. Tell Afis: Venturi 2000, fig. 5.9–22; 2007, figs. 49:1–12, 60:1–11 (kraters), 50:1–19, 61:1–12 (jars/amphoras); 2010, figs. 8:12–16, 10:1–9; 2013, figs. 7:12–16, 8:1–10 (kraters/fusiform jars). Ugarit: Monchambert 1983, fig. 3:19–20.

<sup>58</sup> Kilise Tepe: Hansen and Postgate 2007, 344. Mersin-Yumuktepe: Sevin and Köroğlu 2004, 80. Tarsus-Gözlükule: Goldman 1956, 203; Yalçın 2013. Tille Höyük: Summers 2013, 317. Arslantepe/Malatya: Manuelli 2013, 380. Karkamiš: Giacosa and Zaina (forthcoming). Norşuntepe: Korbel 1985, fig. 74; Müller 2005, 109. Lidar Höyük: Müller 1999, 123; 2005, 110.

<sup>59</sup> Janeway 2017, 46, 50.

<sup>60</sup> Janeway 2008, 2011, 2017.

<sup>61</sup> Furumark 1941a, 1941b.

<sup>62</sup> Janeway 2011, 169–70; 2017, 52–4.

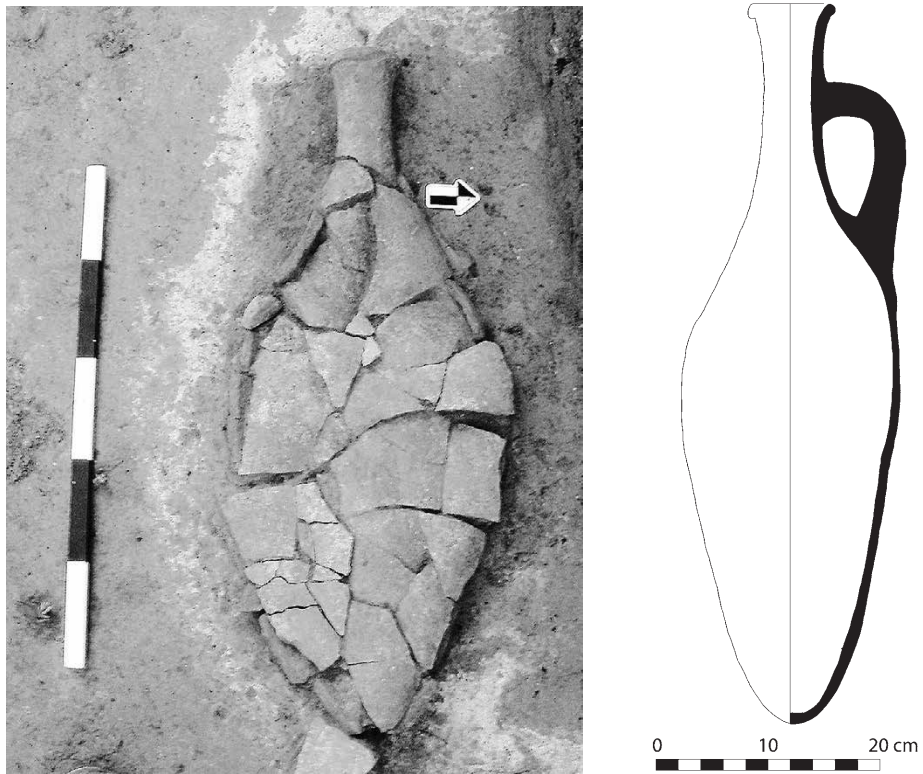

FIG. 13. Fusiform jar G4.55:28, TT-58, FP6c: *left*, in situ; arrow points north (S. Batiuk); *right*, drawing of reconstructed jar (drawing by F. Haughey).

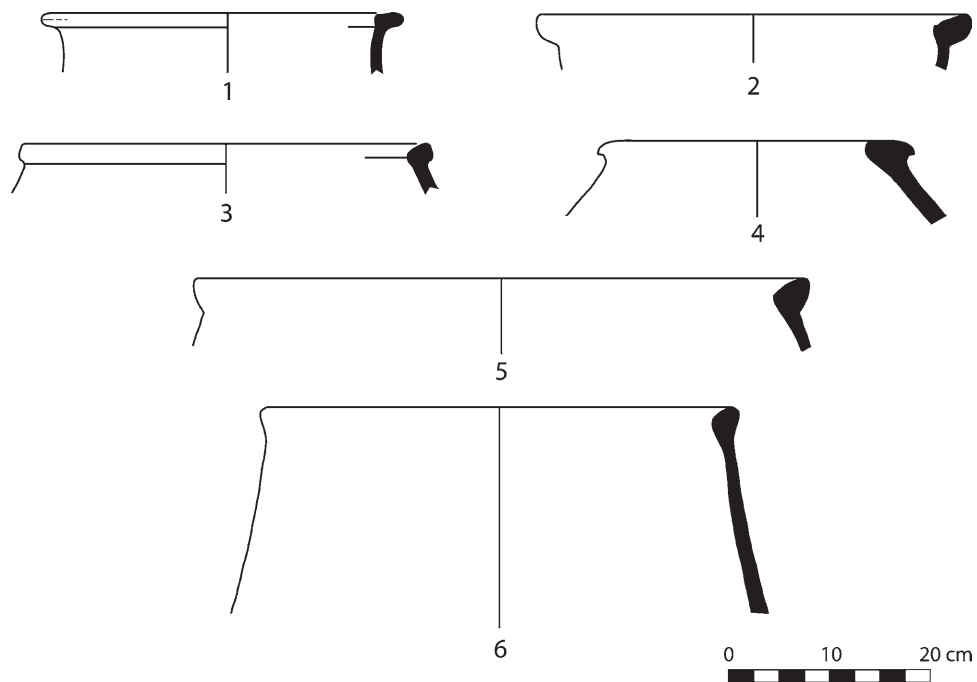

FIG. 14. Plain Ware kraters and pithoi; FP6c: 2, 6; FP6b: 3–5; FP6a: 1 (drawings by L. Welton).

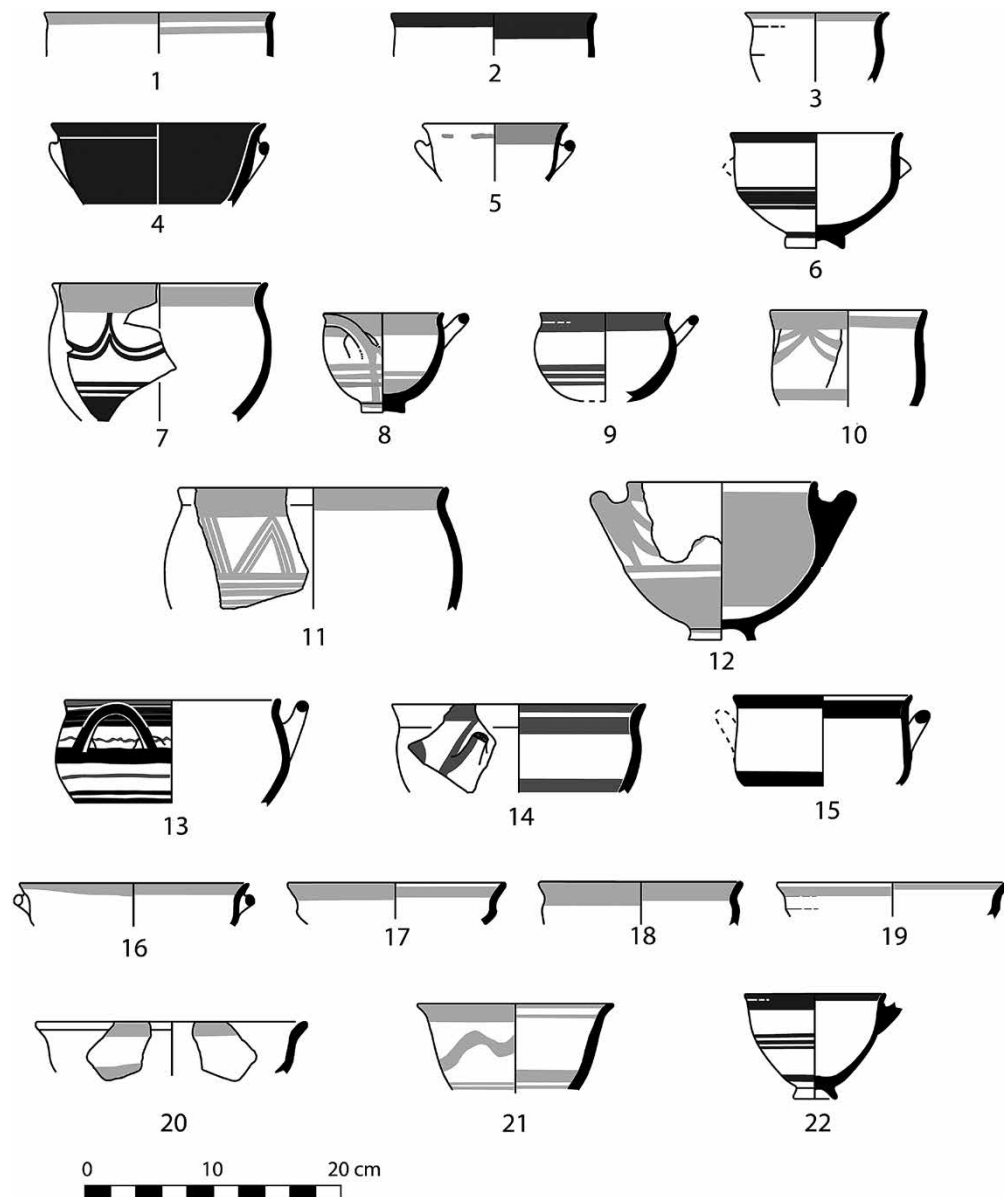

FIG. 15. LH IIIIC-style pottery bowls: FP6c: 1, 2, 16, 17; FP6b: 3–5, 21; FP6a: 6–10, 18; FP5a: 11–14, 19, 20, 22; FP3: 15 (drawings by B. Janeway and L. Welton).

These bowls are characterized by a relatively simple repertoire of painted motifs consisting of Wavy Line Style (see fig. 15, no. 13), linear (see fig. 15, nos. 1–3, 5, 6, 9, 14, 15), monochrome (see fig. 15, nos. 4, 12), and a limited selection of other designs, such as anti-thetic tongue or streamers (see fig. 15, nos. 7, 10) and stacked zigzags (see fig. 15, no. 11).<sup>63</sup> Linear motifs are the most common motifs in the earliest phases. Deep bowls are also well represented at Çatal Höyük and Tell Judaidah and are common at coastal sites in Syria

and Lebanon, such as Ras Ibn Hani (see fig. 1[24]), Tell Tweini (see fig. 1[25]), Sarepta (see fig. 1[35]), and Tell Kazel (see fig. 1[31]), and in Cilicia, appearing in large numbers at Tarsus-Gözlükule.<sup>64</sup> The presence of deep bowls is also attested at inland Syrian

<sup>63</sup>Janeway 2017, 54–8.

<sup>64</sup>Çatal Höyük and Tell Judaidah: Swift 1958, 66, figs. 19–21; Pucci (forthcoming). Ras Ibn Hani: du Piéd 2008, figs. 7:c–f, 8:d; 2011, fig. 10:a–c. Tell Tweini: Jung 2010, 116, fig. 5. Sarepta: Koehl 1985, fig. 20:192–96. Tell Kazel: Badre et al. 2005, figs. 6–8; Jung 2006, figs. 14:60 (unpainted), 15:61–4, 17:73–8; 2007, figs. 7, 8, 10; Capet 2008, figs. 6, 9, 11. Tarsus-Gözlükule: Goldman 1956, figs. 330, 331f; Mountjoy 2005a, figs. 8–14.

sites such as Tell 'Acharneh (see fig. 1[27]), Hama, Tell Afis, Tell Qarqur (see fig. 1[21]), and 'Ain Dara (see fig. 1[18]).<sup>65</sup> Other Aegean bowl types have also been found, including shallow angular bowls (SABs, FS 295; see fig. 15, nos. 16–20) and one-handled conical bowls (FS 242; see fig. 15, nos. 21, 22).<sup>66</sup> SABs in particular are well known from coastal sites such as Tarsus-Gözlükule, Kinet Höyük, Ras Ibn Hani, and Tell Kazel, and they also appear inland at sites like Çatal Höyük and Ğindāris (see fig. 1[17]).<sup>67</sup> Conical bowls, on the other hand, are less widely distributed in the region but are common at Tarsus-Gözlükule.<sup>68</sup>

The LH IIIC style tradition enjoyed widespread distribution in the north Orontes Valley and has been reported at up to 29 other sites by the AVR P Survey,<sup>69</sup> as well as at Ğindāris and Tell Atchana (Alalakh).<sup>70</sup> According to Swift, painted wares accounted for 90–95% of the total Phase N assemblage recovered by the Syrian-Hittite Expedition.<sup>71</sup> However, this figure clearly reflects the expedition's preoccupation with painted wares and therefore substantially overestimates its frequency in the overall assemblage, skewing assessments of its prevalence in the Tayinat Iron I ceramic repertoire.<sup>72</sup> In fact, painted ceramics occur comparatively infrequently in FP6c, representing on average only 5% of the assemblage, and, among these painted vessels, LH IIIC-style material is extremely rare. It is only during FP6b that painted pottery in general, and Aegeanizing ceramics more specifically, begin to increase. Painted ceramics reach approximately equal or slightly higher frequencies compared to Plain

Wares in FP6a and FP5, before decreasing slightly to represent approximately 15% of the assemblage in FP3.

Toward the later part of the Iron I, the north Orontes Valley witnessed the gradual eclipse of the Aegeanizing tradition and its development into local painted wares that occur along with the dominant ceramic type of the Iron II, Red Slip Burnished Ware, a trend that also has been observed elsewhere in the region. However, the absence of intact levels in the Field 1 sequence that date to the latest part of the Iron I period (Iron IC) means that this Iron I–II transition, and the disappearance of the LH IIIC-style pottery tradition at Tayinat, will not be addressed here.

*Local Painted Ware.* Painted pottery reflecting local or regional influences occurs along with the locally produced LH IIIC tradition as well as hybrid forms of both (figs. 16, 17).<sup>73</sup> The fabric characteristics of Local Painted Ware are consistent with those described for both Plain Wares and LH IIIC-style pottery and vary between very fine and moderately coarse examples, often displaying light burnishing or smoothing of the outer surface. Paint most commonly ranges in color from red to brown but occasionally occurs in dark brown-black. Decorative designs are predominantly restricted to geometric motifs,<sup>74</sup> with the most frequent patterns comprised of hatched triangles, parallel straight lines, and wavy lines framed by parallel lines. Many of the painted wares at Tayinat display a high degree of hybridization and thus simultaneously display elements of the influences of multiple traditions, a feature noted at many coastal sites during this transitional period.<sup>75</sup>

Common forms include carinated or biconical (see fig. 16, no. 1), bell-shaped (see fig. 16, no. 2), and amphoroid (see fig. 16, nos. 3, 4) kraters, other kraters whose body shape is uncertain (see fig. 16, nos. 5–7), and both rim- and neck-handled amphoras and jars (see fig. 17, nos. 1–6). Other forms, represented in smaller numbers, include trefoil-mouthed pitchers (FS 137; see fig. 17, no. 7) and mugs (see fig. 17, no. 8) as well as feeding or spouted bottles (FS 159–62)<sup>76</sup> and pilgrim flasks (FS 186–88).

Some Local Painted Ware forms find parallels in the Anatolian and coastal Syrian Late Bronze Age–Iron I

<sup>65</sup> Tell 'Acharneh: Cooper 2006, fig. 15.11. Hama: Riis 1948, figs. 89, 90. Tell Afis: Venturi 2010, fig. 11:1–3; 2013, fig. 15. Tell Qarqur: Dornemann 2003, fig. 88.5. 'Ain Dara: Stone and Zimansky 1999, fig. 27.1.

<sup>66</sup> Janeway 2017, 59–60.

<sup>67</sup> Tarsus-Gözlükule: Goldman 1956, pl. 332.1266–68; French 1975, 61, figs. 16, 17; Mountjoy 2005a, 126, figs. 15, 17. Kinet Höyük: Gates 2010, 72, fig. 8. Ras Ibn Hani: Bounni et al. 1979, fig. 25.3–4; du Piéd 2008, fig. 7g; 2011, fig. 10E. Tell Kazel: Jung 2006, 191, 197, fig. 18:83. Çatal Höyük: Pucci 2013, figs. 6.3–4, 6; (forthcoming), 141–42, fig. 44:11. Ğindāris: Muhlenbruch et al. 2009, pl. 2.

<sup>68</sup> Mountjoy 2005a, 83, 99–100, figs. 6, 7, 17.

<sup>69</sup> Janeway 2017, 33; see also Verstraete and Wilkinson 2000, 188–89.

<sup>70</sup> Ğindāris: Sürenhagen 1999, 163. Tell Atchana (Alalakh): Yener 2013, 20–1; Koehl 2017.

<sup>71</sup> Swift 1958, 64.

<sup>72</sup> Janeway 2017, 121.

<sup>73</sup> Janeway 2017, 91–2, 106–7, 115–17.

<sup>74</sup> Janeway 2017, 78–91.

<sup>75</sup> du Piéd 2008, 171; Jung 2012; Janeway 2017, 92.

<sup>76</sup> Swift 1958, 68, fig. 25; Pucci (forthcoming, 175–76).

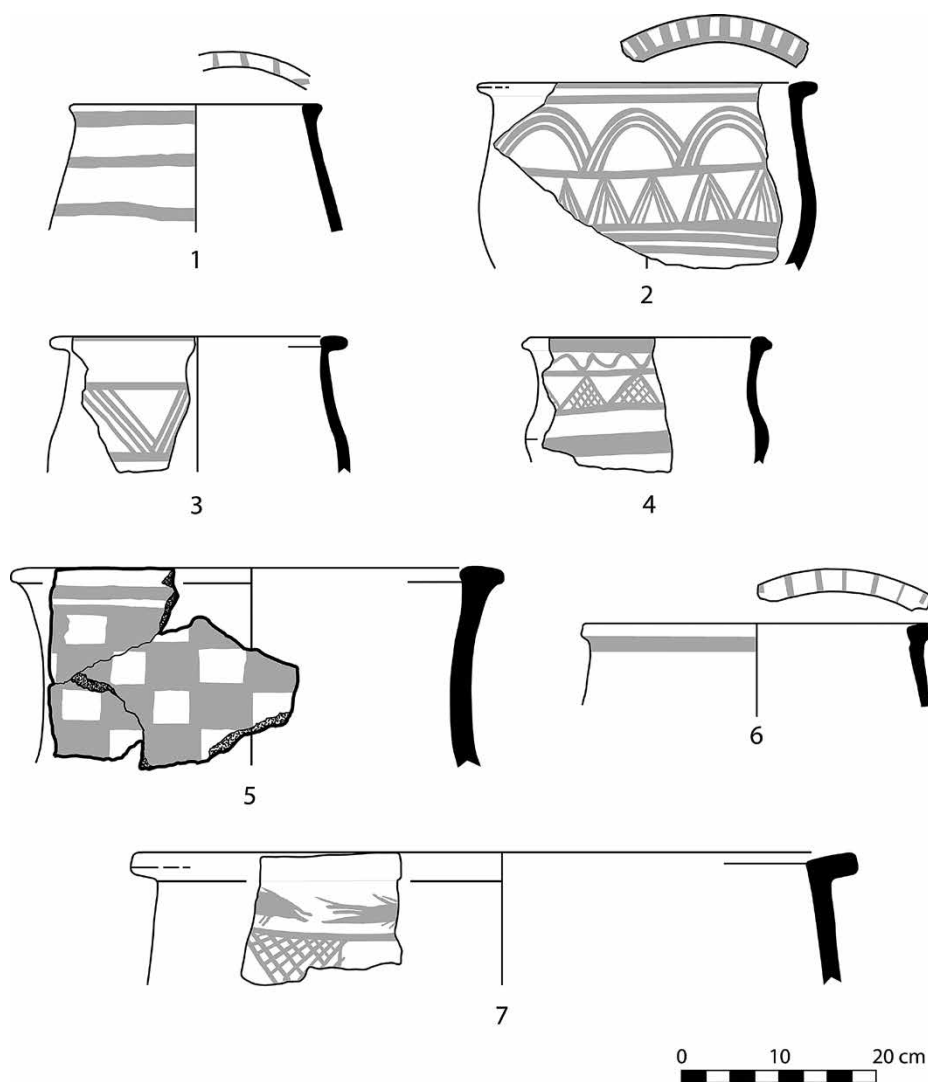

FIG. 16. Local painted pottery kraters: FP6b: 1, 3, 4; FP6a: 6, 7; FP6: 2; FP5a: 5 (drawings by B. Janeway and L. Welton).

repertoire. The biconical krater, with a low carination (see fig. 16, no. 1), is a common Late Bronze Age Levantine form.<sup>77</sup> Kraters with square or rectangular rims (see fig. 16, nos. 6, 7), which are also represented (although less frequently) in the Plain Ware assemblage, are common in Late Bronze Anatolian and coastal Syr-

ian contexts elsewhere, in addition to being related to the LH IIIC tradition.<sup>78</sup> The trefoil-mouthed pitcher (see fig. 17, no. 7) finds close parallels both in shape and decoration in the Late Bronze and Late Bronze–Iron Age transitional period levels at Kilise Tepe, Mersin-Yumuktepe, and Tarsus-Gözlükule, and in the

<sup>77</sup>Tell Kazel: Capet 2003, figs. 6e, 8c (Area II, Level 6). Çatal Höyük: Pucci 2013, fig. 2:16; (forthcoming), 137, 142, 145, figs. 43:6–8, 44:15. Tarsus: Korbel 1987, figs. 43.348, 351. Tille Höyük: Summers 1993, fig. 38.12. See also examples from the southern Levant: Beth Shean: Panitz-Cohen 2009, 249–50, Type JG75; Megiddo: Arie 2013, 505, Type J10; Martin 2013, 387–88, Type JG70; among others.

<sup>78</sup>Mersin: Sevin and Köroğlu 2004, fig. 7.4. Kilise Tepe: Hansen and Postgate 2007, figs. 389.652, 399.795. Ras Ibn Hani: du Pied 2008, figs. 10, 11. Tell Afis: Venturi 2007, figs. 56:3, 58:1, 9. Ugarit: Monchambert 2008, fig. 1a, c. Tell Kazel: Badre 2006, fig. 13:3. Tell Tweini: Vansteenhuyse 2010, figs. 3:1, 5–11.

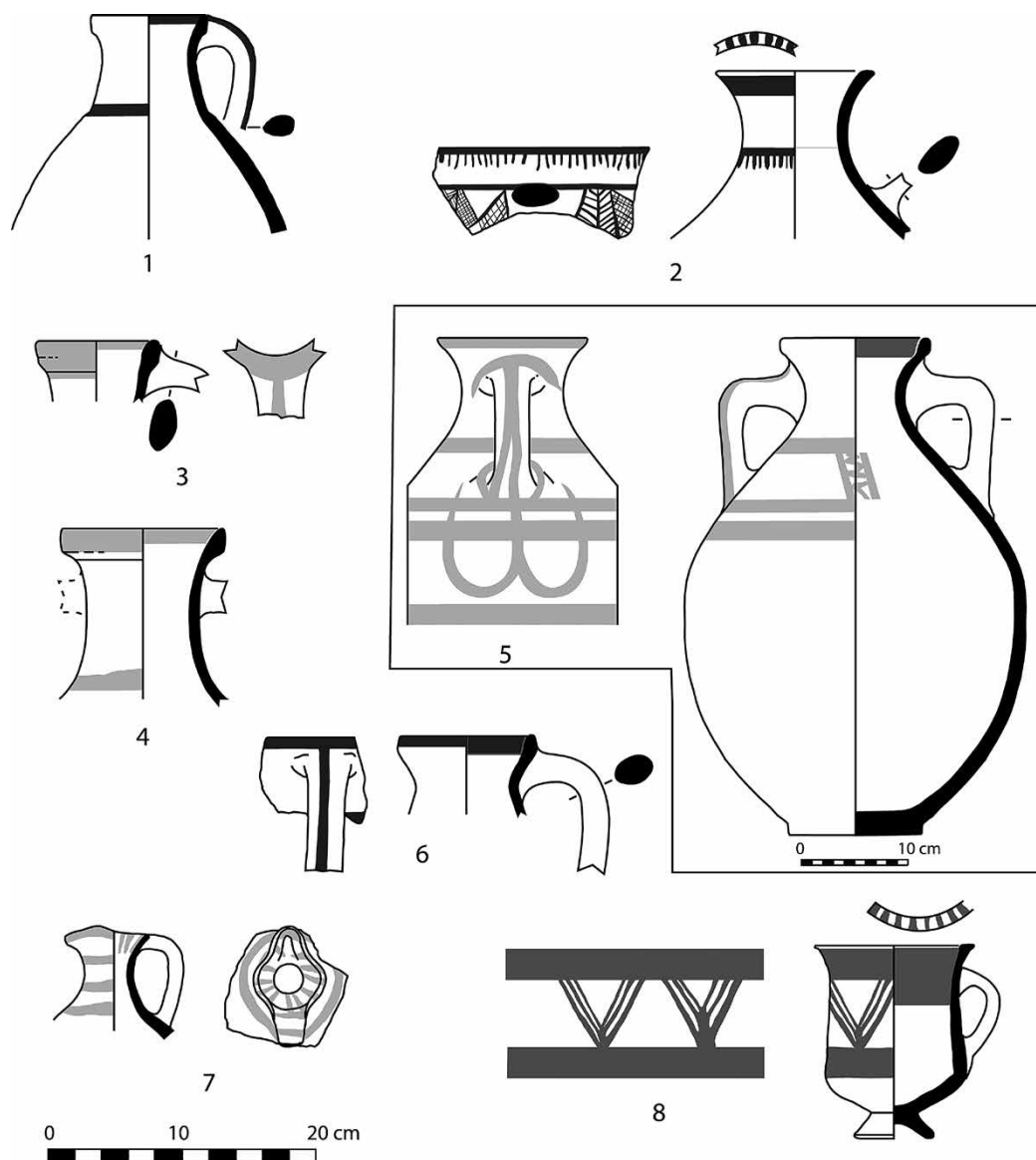

FIG. 17. Local painted pottery: 1–6, amphoras; 7, 8, other forms; FP6b: 3; FP6a: 1, 2, 7, 8; FP5a: 4, 5; FP3: 6 (drawings by F. Haughey, B. Janeway, and L. Welton).

Early Iron Age levels at sites in both the northern and southern Levant.<sup>79</sup>

In Cilicia, after an emphasis on plain ware potting traditions for much of the Late Bronze Age, evidence for local painted pottery called Cilician Red Painted Ware first appears at Kilise Tepe before achieving

more widespread distribution in Late Bronze (LB) IIB levels at Mersin-Yumuktepe, Tarsus-Gözlükule, and Kinet Höyük.<sup>80</sup> In recent years, it has been suggested that these painted traditions represent revivals of earlier local pre-Hittite ceramics.<sup>81</sup> In contrast, in the

<sup>79</sup> Kilise Tepe: Hansen and Postgate 2007, fig. 392.697. Mersin-Yumuktepe: Garstang 1953, figs. 160:1, 161:9, 12. Tarsus-Gözlükule: Goldman 1956, fig. 380.1077. Northern Levant (Tell Kazel): Badre et al. 1990, fig. 39g. Southern Levant: Dothan and Zukerman 2004, figs. 27.8, 30.7.

<sup>80</sup> Kilise Tepe: Level III; Bouthillier et al. 2014, 105, 138. Mersin-Yumuktepe: Sevin and Köroğlu 2004, fig. 7. Tarsus-Gözlükule: Ünlü 2005, figs. 4, 5; 2015. Kinet Höyük: Gates 2013a, fig. 8; 2013b, figs. 4, 5, 8, 11.

<sup>81</sup> Genz 2003, 187; 2005, 76, 82; Müller 2005, 111; Postgate 2007, 145–46.

Levantine coastal region and the Syrian interior, a Late Bronze Age painted tradition continues into the Iron I and appears in transitional levels at 'Ain Dara, Tell Afis, Hama, Ugarit, Ras Ibn Hani, Ras el-Bassit (see fig. 1[22]), Tell Tweini, Tell Kazel, and Tell Arqa (see fig. 1[32]).<sup>82</sup> More locally, continuity in the painted tradition can be observed at Tell Atchana (Alalakh) and Çatal Höyük.<sup>83</sup> This reflects the persistence of a broader Late Bronze Age painted tradition, albeit with Aegean stylistic influences, that also continues in parts of the southern Levant.<sup>84</sup>

*Shell-Tempered Cooking Ware.* A shell-tempered ware constitutes the main ware type used for cooking vessels in the Iron I assemblage (fig. 18). The distinguishing feature of this ware type is the heavy use of crushed shell temper in the production of large, closed, hand-made vessels. Frequent mottling on their exterior surfaces confirms that these vessels were used for cooking. Shell-Tempered Cooking Ware appears throughout all phases of the Iron I in Field 1 (FPs 6–3). In the earliest phases, shapes consist of closed, carinated forms, often with two handles and a tall upper portion, with a thickened oval rim (see fig. 18, nos. 1, 2, 4) or with a ridge running along the exterior of the rim (see fig. 18, nos. 3, 5, 6). Rim shapes become more variable in the later phases of Iron I (see fig. 18, no. 7), but a preference for the carinated form is generally retained throughout the period.

The use of crushed shell as a tempering agent for cooking pots has a long tradition both in the Amuq, as attested at Çatal Höyük throughout Amuq Phases M and N, and at Tell Atchana (Alalakh) from the LB I onward.<sup>85</sup> It also appears at Tell Afis and in Cilicia,

where it is encountered at Tarsus-Gözlükule from at least the LB I.<sup>86</sup> Tayinat cooking pot forms generally continue the Late Bronze Levantine carinated cooking pot tradition. Similar continuity in cooking pot forms and ware types from the Late Bronze to the Iron Age has been observed at Tell Afis and at Çatal Höyük.<sup>87</sup>

A small number of Aegean-style cooking pots have also been found (see fig. 18, nos. 8, 9), but these account for less than 5% of the cooking ware assemblage.<sup>88</sup> These vessels feature an ovoid body, rounded shoulder, short everted neck, simple rim, disc base, and a single loop handle from rim to shoulder; they are also shell tempered. Although common in Cyprus and the southern Levant, this cooking pot tradition does not appear to be widely distributed in the northern Levant, having thus far been identified in small numbers only at Tell Kazel and Tell Arqa.<sup>89</sup>

*Gray Ware.* Other ware types appear in the assemblage at Tayinat in very small quantities. The most frequent of these is Gray Ware (fig. 19). Gray Wares at Tayinat have a very fine texture and were fired in a reducing environment, resulting in a light- to medium-gray surface color and a thick, well-delineated dark gray to black core. The vessels are generally well burnished and in very rare cases display incised decoration. The most frequently attested forms include carinated bowls and cups, sometimes with high-swung handles (see fig. 19, nos. 3–5). Similar forms are found at Tell Kazel.<sup>90</sup>

Gray Ware is indigenous to northwest Anatolia, as attested at Troy (see fig. 1[46]) throughout the Late Bronze Age and well into Early Iron Age levels, following the destruction horizon of Level VIIa.<sup>91</sup> Gray Ware has also been found in limited amounts throughout the eastern Mediterranean, primarily at coastal sites, where it typically occurs in terminal Late Bronze Age levels or post-destruction contexts.<sup>92</sup> Recent neutron

<sup>82</sup> 'Ain Dara: Stone and Zimansky 1999, 70. Tell Afis: Venturi 2007, figs. 56:2, 3, 58; 2010, fig. 11:4–13. Hama: Riis 1948, figs. 123–27. Ugarit: Monchambert 2008, 150–51, fig. 1a–c. Ras Ibn Hani: Lagarce and Lagarce 1988; du Piéd 2008, figs. 10, 11. Ras el-Bassit: Courbin 1986, figs. 11, 14. Tell Tweini: Vansteenhuyse 2010, 98–9, fig. 3; Vansteenhuyse and Bretschneider 2011, 190–91. Tell Kazel: Capet and Gubel 2000, 438–41, figs. 12–14; Capet 2003, figs. 6c, 8c, 21:11 (Area II, Level 6), 37c, 44a (Area II, Level 5); Badre 2006, fig. 13:3. Tell Arqa: Charaf 2008, 80–1; 2011, fig. 4.

<sup>83</sup> Woolley 1955, 318–20; Pucci 2013, 98–9.

<sup>84</sup> Particularly in the Jezreel and Beth Shean areas, the coastal plain, and the Shephelah; Mazar 2015, 6, 8–9. Beth Shean: Panitz-Cohen 2009, 211–18, Type KR71. Megiddo: Killebrew 2005, 119, 132, figs. 3.17, 3.31, Jug Type CA17; Arie 2013, 491, Type K2; Martin 2013, 370, Type KR70.

<sup>85</sup> Çatal Höyük: Pucci 2013, 92–3, 99; (forthcoming),

160–63. Tell Atchana (Alalakh): Horowitz and Çakırlar 2017, 233–35.

<sup>86</sup> Tell Afis: Venturi 2010, 7. Tarsus-Gözlükule: Ünlü 2016, 6, fig. 9.

<sup>87</sup> Tell Afis: Venturi 2010, figs. 9:7–11, 12:1–5; 2013, fig. 14:1–2. Çatal Höyük: Pucci (forthcoming), 160, fig. 50.

<sup>88</sup> Janeway 2017, 111.

<sup>89</sup> Tell Kazel: Jung 2012, fig. 10.2:6. Tell Arqa: Charaf 2011, 207–8.

<sup>90</sup> Badre 2006, fig. 17:10–11.

<sup>91</sup> Becks 2003, 49; Pavúk 2010, 2014.

<sup>92</sup> Allen 1991, 152; 1994, 40–1; Badre 2006, fig. 17:7–12; Jung 2012, 109.

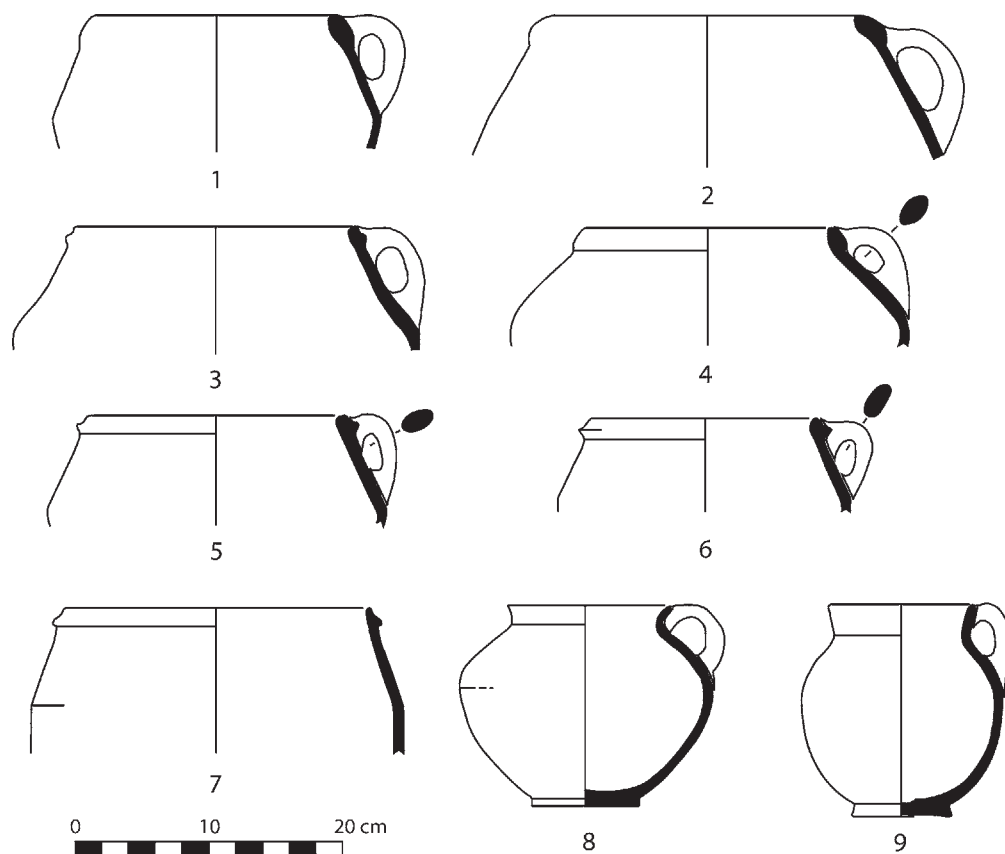

FIG. 18. Shell-Tempered Cooking Ware: FP6c: 1–3; FP6b: 4, 5; FP6a: 6–9 (drawings by F. Haughey and L. Welton).

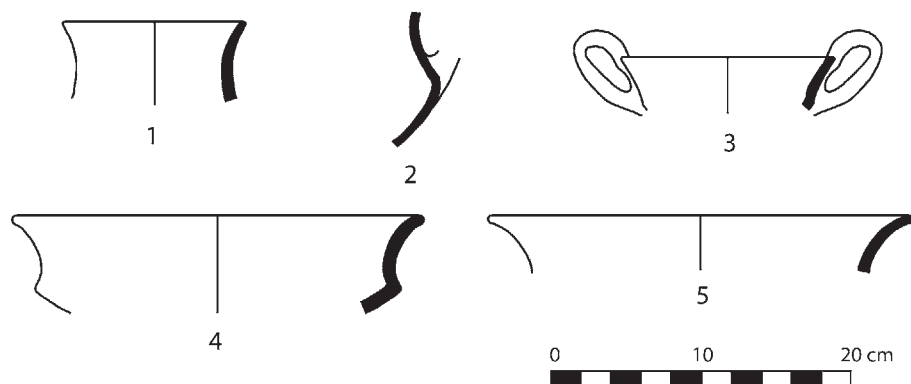

FIG. 19. Gray Ware: FP6c: 1, 2; FP6b: 3–5 (drawings by L. Welton).

activation analysis suggests that most eastern Mediterranean examples of Gray Ware are likely to be Trojan imports, although a few examples appear to be of unknown (local?) origin.<sup>93</sup>

<sup>93</sup> Badre et al. 2005, 31–2; Mommsen and Pavúk 2007, 29, table 1; Boileau et al. 2010, 1686; Jung 2012, 109–10.

#### *Small Finds*

Many of the small finds from the Iron I levels at Tayinat relate to specialized craft production, particularly metal and textile production, and are presented collectively in discussions below devoted to those particular industries. Notable artifacts are illustrated and discussed with the aim of describing the most readily identifiable artifact types represented.



Many of the small finds recovered from the Iron I levels in Field 1 were associated with weaponry, both of iron and copper. The most common types of weaponry are arrowheads, which occur most frequently in the earliest phase (FP6) and are mostly of copper alloy (fig. 20, nos. 1–4), although iron examples are also present (see fig. 20, no. 5). A copper alloy spearhead (FP6; see fig. 20, no. 6) and a small number of armor scale fragments of both copper alloy and iron (see fig. 20, nos. 7, 8) were also found in Iron I levels. The armor scales are flat, with a raised longitudinal central ridge, squared at one end and rounded at the other. Armor scale pieces of this type are common in the Late Bronze and Early Iron Age Levant,<sup>94</sup> including at Tell Atchana (Alalakh), Ugarit, Tell Arqa, and Hama; they also occur in Greece and Cyprus in this period.<sup>95</sup>

Two iron blades (FP6b) display pseudomorphic traces of organic materials representing possible textile wrappings, and one displays traces of its wooden handle and several metal rivets still visible on both sides of the blade (see fig. 20, nos. 9, 10).

Metal artifacts associated with personal ornamentation include a variety of pins and needles (fig. 21, nos. 1–5) and a small number of copper alloy rings (see fig. 21, no. 8). Three copper alloy fibulae display an asymmetrical bow shape, with beaded decorative moldings on the body, a hooked clasp, and a spiral spring (see fig. 21, nos. 6, 7). This asymmetrical shape evolves into a more symmetrical bow shape or a somewhat triangular shape in the Iron II.<sup>96</sup> Similar examples are found in LB II–Iron I levels at Tell Kazel, Tarsus-Gözlükule, Tell Tweini, Hama, and Tell Atchana (Alalakh).<sup>97</sup>

A double spiral of gold wire may represent part of an earring; its central portion retains a section of intact gold sheet rolled into a tube (see fig. 21, no. 9). A small gold-foil spherical object (see fig. 21, no. 10) is similar to a collection of items uncovered in the Late Bronze Age North Palace at Ras Ibn Hani, where they

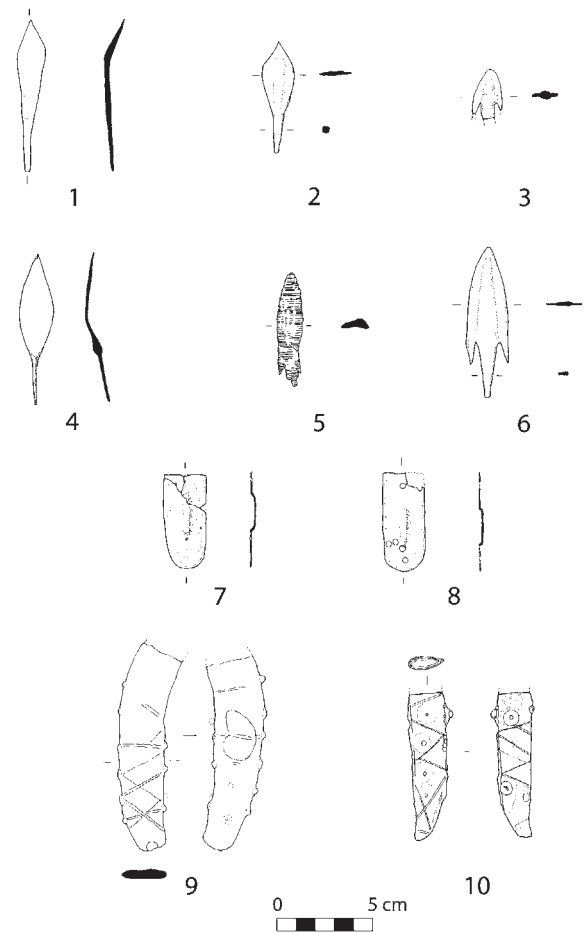

FIG. 20. Metal weaponry: 1, TT-358; 2, TT-695; 3, TT-1384; 4, TT-1879; 5, TT-170; 6, TT-691; 7, TT-451; 8, TT-452; 9, TT-1385; 10, TT-36; FP6a: 2, 4, 9; FP6: 6; FP5b: 1, 8, 10; FP4: 3, 7; FP3: 5 (drawings by F. Haughey).

were interpreted as gold veneers for nail heads.<sup>98</sup> Finally, the Iron I settlement in Field 1 produced a thin strip of repoussé silver or electrum (see fig. 21, no. 11).

The Field 1 excavations produced a wide variety of beads, including examples made from shell, glass, serpentine, carnelian, frit, bone, and ceramic. A teardrop-shaped carnelian pendant (fig. 22, no. 1), commonly known as a Lotus Seed pendant, is represented to date by three examples. These pendants have numerous parallels in both shape and material at Beth Shean (see fig. 1[39]), Tel Miqne-Ekron (see fig. 1[42]), Ashdod (see fig. 1[41]), and Hama.<sup>99</sup> Such pendants

<sup>94</sup> See Karageorghis and Masson 1975, Maran 2004 for summaries of similar finds.

<sup>95</sup> Tell Atchana (Alalakh): Woolley 1955, 277, pl. 71: AT/38/137a–b. Ugarit: Schaeffer 1962, 95, fig. 61c, i. Tell Arqa: Thalmann 2006, pl. 144:9. Hama: Riis 1948, 124, fig. 143. For Greece and Cyprus, see Maran 2004 for their distribution and associated bibliography.

<sup>96</sup> Stronach 1959, fig. 1:4–5.

<sup>97</sup> Tell Kazel: Badre et al. 1990, fig. 40a. Tarsus-Gözlükule: Goldman 1956, fig. 432:246. Tell Tweini: Bretschneider and Van Lerberghe 2010, fig. 58. Hama: Riis 1948, 132–33, figs. 167, 168. Tell Atchana (Alalakh): Woolley 1955, 277, pl. 73:F3; apparently iron, from “upper soil.”

<sup>98</sup> Bounni et al. 1998, fig. 126.

<sup>99</sup> Beth Shean: Golani 2009, 620–21. Tel Miqne-Ekron: Golani in Ben-Shlomo 2006, 195–96. Ashdod: Golani and Ben-Shlomo 2005. Hama: Riis 1948, fig. 204.

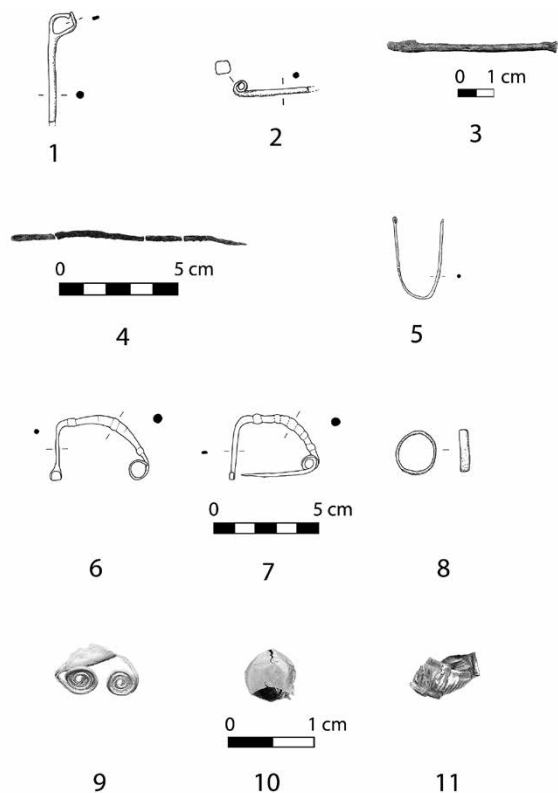

FIG. 21. Jewelry, personal ornamentation, and small metal finds: 1, TT-1968; 2, TT-2030; 3, TT-990; 4, TT-555; 5, TT-661; 6, TT-531; 7, TT-623; 8, TT-1198; 9, TT-557; 10, TT-1861; 11, TT-439; FP6c: 1, 2; FP6b: 8, 10; FP6a: 11; FP6: 3, 5-7; FP5b: 4, 9 (A. Harrison, S. Harrison, and J. Jackson; drawings by F. Haughey).

are generally considered to be Egyptianizing and are most common in the LB II–Iron I, particularly during the 19th and 20th Dynasties.

Iron I ceramic figurines from Field 1 are fragmentary and primarily zoomorphic, most commonly representing quadruped bovine or equine forms. A single anthropomorphic ceramic figurine with a cylindrical body and schematic face was recovered (see fig. 22, no. 2).

A perforated ivory object in the shape of an animal paw, likely that of a lion, possibly served as an amulet (see fig. 22, no. 3), as did a small anthropomorphic faience male figure perforated transversely just above the shoulder (see fig. 22, no. 4). Similar Egyptian or Egyptianizing faience amulets are well known from Beth Shean, Lachish (see fig. 1[45]), and Hama.<sup>100</sup>

<sup>100</sup> Beth Shean: Late Bronze–Iron I; Herrmann 2009. Lachish: Late Bronze–Iron I; Tufnell 1953, 378–81, pls. 34–6; 1958, 89, pl. 29:52–68. Hama: Riis 1948, fig. 206.

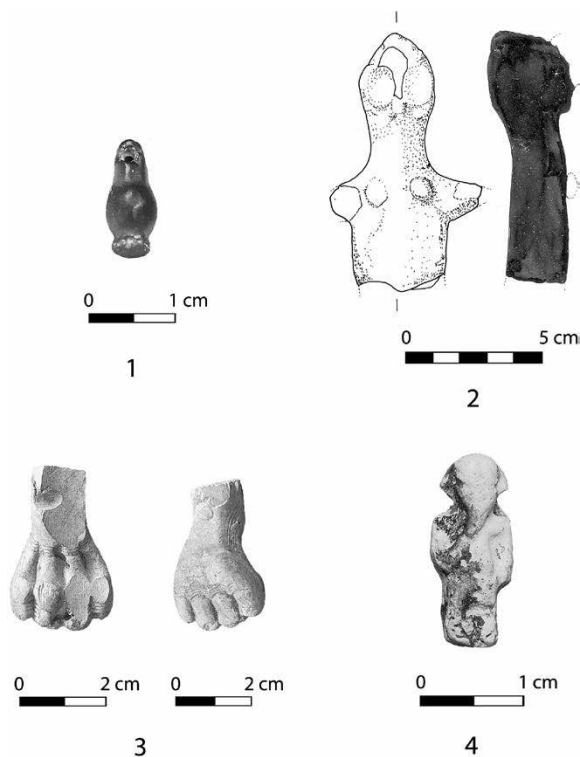

FIG. 22. Small finds: 1, jewelry; 2, figurine; 3, 4: amulets; 1, TT-1156; 2, TT-1387; 3, TT-2208; 4, TT-435; FP6b: 1, 2; FP6a: 3, 4 (S. Harrison and J. Jackson; drawings by F. Haughey).

Glyphic remains from the Iron I levels at Tayinat are rare. A bulla from FP6c displays most of a seal impression from a circular seal that is similar to known Hittite seals and seal impressions (fig. 23). A border consisting of a series of tick marks frames a series of Hieroglyphic Luwian signs in the central circle. They include an oval sign with hatched markings that also appears on several seals from Boğazköy.<sup>101</sup> The second sign does not clearly match any discernable Hieroglyphic Luwian sign, and the identification of both signs remains uncertain.<sup>102</sup> Of potential chronological significance is the flat (rather than concave) profile of the impression and the small size of the central field containing the Hieroglyphic Luwian signs. These features suggest a comparatively early date (late 15th–early 14th century B.C.E.),<sup>103</sup> indicating that this seal was likely an heirloom at the time of its deposition.

<sup>101</sup> Güterbock 1967, 2, nos. 172, 188, 196.

<sup>102</sup> Depending on the impression's orientation, the first sign should probably be identified as L.409 (Laroche 1960, 216; M. Weeden, pers. comm. 2018).

<sup>103</sup> Herboldt 2006, 102.

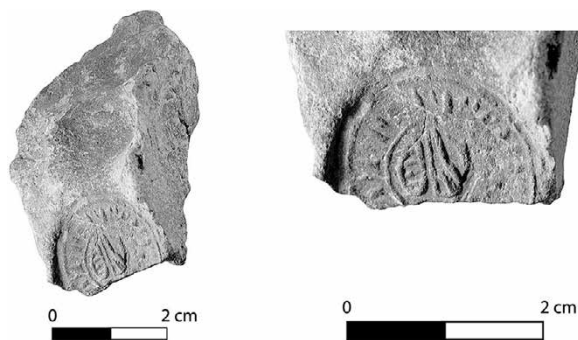

FIG. 23. Hieroglyphic Luwian bulla G4.56:240, TT-1969, FP6c (J. Jackson).

### Textile Industry

Excavations in Field 1 have produced more than 200 nonperforated, cylindrical clay loomweights (fig. 24, nos. 1–5). Often described as spool weights,<sup>104</sup> these distinctive indicators of textile production are commonly found in LH IIIC levels at sites throughout the Aegean, most notably at Mycenae and Tiryns.<sup>105</sup> More recently, they have been recognized in Early Iron Age levels at an increasing number of sites in the Levant, inland Syria, and southern Anatolia, generally in association with Aegeanizing pottery.<sup>106</sup> Their exact time and place of origin is still unclear, but they seem to spread rapidly throughout the eastern Mediterranean in the early 12th century B.C.E.<sup>107</sup>

Tayinat's Iron I loomweights occur in a variety of sizes, but two size ranges predominate: a smaller size averaging 7–8 cm in length and weighing approximately 170–180 g, and a larger size averaging 10–12 cm in length and 550–560 g in weight. Generally speaking, larger, heavier loomweights give way to smaller, lighter examples from the earlier to the later phases of the Iron I, likely indicating a change in the functionality of these objects and suggesting a shift over time from heavier, coarser fabrics to lighter, finer fabrics.<sup>108</sup> Two general shapes typically occur, though variation is common: cylindrical forms with straight sides and rounded ends, and hourglass-shaped forms with a tapered mid-section and flattened ends, some-

times with a small indentation in one or both ends. Morphological developments over time are difficult to discern, with both types occurring in all FPs.

Although most examples were found individually, many Field 1 loomweights were found in caches deposited in pits, occurring exclusively in FP6.<sup>109</sup> Cylindrical loomweights become less common toward the end of the Iron I, although they continue to appear during the Iron II, when they occur along with a new type of perforated stone loomweight that eventually replaces them in the Iron III.<sup>110</sup>

To date, 73 spindlewhorls have been recovered from Iron I contexts in Field 1. This total represents two main categories: primary use objects, deliberately fashioned for spinning (50 examples), and perforated sherd-discs made from reused potsherds (23 examples). Among the first group, examples occur in both clay (see fig. 24, nos. 6–8) and stone (see fig. 24, nos. 9–12). Morphologically, there is a distinct preference for conical shapes (see fig. 24, nos. 8, 9, 11), although round and biconical forms were also popular (see fig. 24, nos. 6, 7, 10). Occasionally, stone spindlewhorls exhibit finely carved decoration (see fig. 24, no. 11), with patterns including semicircles, concentric rings, and rosettes. Bone spatulas (see fig. 24, no. 13) and awls (see fig. 24, no. 14) complete the repertoire of textile tools.

### Zooarchaeological Remains

The TAP excavations have recovered more than 141,000 fragments of faunal bone, of which nearly 33,000 have been analyzed. The faunal remains assigned to the Iron I make up a total sample of 14,122 fragments, or roughly 40% of the total analyzed sample.

All excavated soil is dry-sifted using quarter-inch mesh screens, and faunal remains recovered from the heavy fraction of floated soil samples have been included in the analysis when available. Bone identification is made with reference to standard zooarchaeological manuals of comparative osteology.<sup>111</sup>

<sup>104</sup> Stager 1995, 346; Rahmstorf 2003, 397–400; 2011, 320.

<sup>105</sup> Rahmstorf 2003, 397, 400–2; 2008, 59–73.

<sup>106</sup> Stager 1995, 346; Rahmstorf 2003, 403–6. Tell Afis: Cecchini 2000, 2011. Ras Ibn Hani: du Piéd 2008, 180; 2011, 220. Tell Tweini: Bretschneider et al. 2010, fig. 6.

<sup>107</sup> Rahmstorf 2005; 2011, 320–22.

<sup>108</sup> Lumb 2014, 143–45.

<sup>109</sup> This depositional pattern appears reasonably common, with loomweight caches also observed at Tiryns and Lefkandi (Evely 2006; Rahmstorf 2008, 2011) and in Phase O contexts at Çatal Höyük (Haines 1971, pl. 16B).

<sup>110</sup> Cecchini 2000, 217.

<sup>111</sup> Boessneck 1963; Boessneck et al. 1964; Schmid 1972; Barone 1976; Hillson 1992.

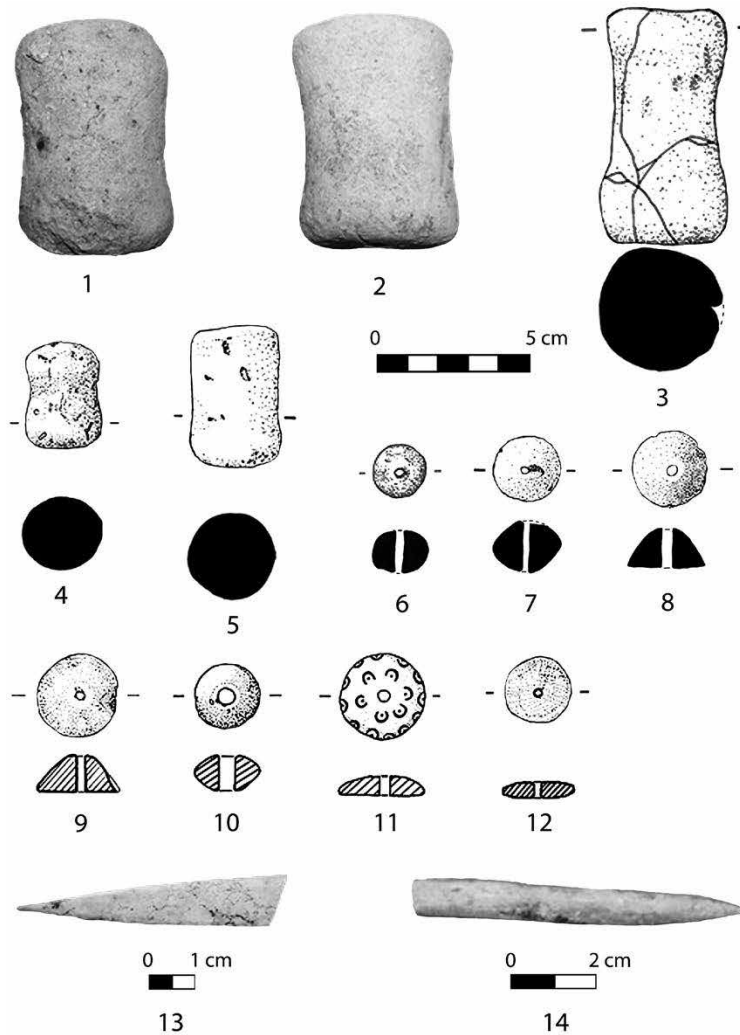

FIG. 24. Evidence of the textile industry at Tayinat: 1–5, loomweights; 6–12, spindlewhorls; 13, weaving tool; 14, leather-working tool; 1, TT-1258; 2, TT-1292; 3, TT-470; 4, TT-463; 5, TT-138; 6, TT-1967; 7, TT-307; 8, TT-668; 9, TT-731; 10, TT-750; 11, TT-564; 12, TT-20; 13, TT-102; 14, TT-1155; FP6b: 6, 7, 9, 10; FP6a: 1, 2, 11, 14; FPSb: 3, 4, 8; FP4–5a: 5; FP3: 12, 13 (S. Harrison; drawings by F. Haughey).

Aging and measurements of individual elements are also based on standard methods.<sup>112</sup>

The raw data from all field phases is presented in table 1 in the online appendix (on AJA Online).<sup>113</sup>

<sup>112</sup> Silver 1963; von den Dreisch 1976; Payne 1985.

<sup>113</sup> FP6 loci analyzed are from FP6b–a; no material from FP6c has yet been analyzed. FP3 is unusual in that one locus (G4.55:10) contained more than 500 fragments of bones from very small mammals representing more than 50 individual rodents and small carnivores. It is likely that they represent the remains of several owl pellets and are thus not reflective of any aspect of the actual Iron I economy of the site. As such, analysis was conducted both including these fragments (“raw” data) and

The smallest sample originates from FP4, represented by 520 bone fragments. All other phases have substantially larger samples, varying from just over 2,000 fragments to more than 6,000. Mammalian bone dominates, but both fish and bird bone are present in all phases in varying amounts. In FP6, a substantial 518 fragments of fish bone (23% of the sample) were recovered. In later Iron I phases, quantities of fish decrease to between about 2% and 4% of the total sample. Bird appears in low frequencies (<1%) throughout all

excluding them (“adjusted” data). References to species proportions are based on “adjusted” data unless otherwise noted.

phases, while turtle/tortoise and amphibian appear in similar amounts, except in FP4, which may be due to this phase's small sample size. Unidentifiable fragments form a significant component of the assemblage in all phases, varying between about 25% and 45% of the sample. Cut marks appear in frequencies of less than 1%, reaching their highest levels in FP5, where they appear on 0.9% of fragments in the sample. Thermal alteration is visible in 1.5–3.3% of fragments, depending on the field phase.

Large mammals (all species larger than ovicaprids) make up a relatively small fraction of the finds in all phases, with four identifiable species present. The proportion of the total sample represented by large mammals is lowest in FP6 (8.4%) and highest in FP3 (14.6%). However, they consistently represent 21–22% of identifiable mammal remains. In all phases except FP4, small amounts of red deer (*Cervus elaphus*) attest to the continuation of large game animal hunting, at least as a small portion of the animal economy. A small number of fragments of equid bone (likely donkey) were also identified in all phases. Pig is consistently present and was at its highest in FP6, at 1.5% of the sample. A single fragment of camel (*Camelus* sp.) in FP3 represents the earliest evidence of this species at Tayinat to date. A single fragment of bear (*Ursus arctos*) was also found in FP3.

Medium-sized mammals comprise most of the mammalian finds in all phases, varying between about 30% and 55% of the total sample, and 73–77% of identifiable mammal remains. Medium-sized game animals are represented most frequently by *Gazella* sp., appearing in frequencies of less than 1% in all phases except FP4. Fallow deer (*Dama dama*) is also represented by one fragment in FP5. Ratios of *Capra* to *Ovis* indicate that throughout the Iron I, goats appear in equal or greater numbers than sheep. This ratio is highest in FP6, where it reaches 2.4:1. Sample sizes of ageable bone and teeth for ovicaprids were large enough to analyze mortality in all phases except FP4. All phases demonstrate a pattern that suggests a herding and culling strategy that emphasized secondary products over meat production. This is particularly notable in FP5, where 25% mortality was reached at 9 months of age, 50% mortality at 22.5 months, and 75% mortality at 40.5 months. The low value for the 25% mortality level is suggestive of dairy production, while the significant number of individuals older than 48 months

suggests that wool and/or hair production also played a significant role.

The remainder of the mammalian bone includes small amounts of rabbit or hare and canid bone (<1% in all phases). A single fragment of beaver (*Castor fiber*) was identified in FP3, while one fragment of cat (*Felis* sp.) was identified in FP5. Small and very small mammals also appear in low frequencies in all phases with the exception of FP3, which shows abnormally high percentages of very small mammal bone (see n. 113 above). The elevated numbers of rodents (mice, voles) and very small carnivores (ferrets, weasels) are likely due to the presence of owl pellets in the sample.

Tayinat's Iron I sample is remarkably consistent in its species distribution, particularly from FPs 5–3. The most notable changes are those that occur between FP6 and FP5. There is a decrease in the amount of pig bone after FP6, possibly reflecting a dietary shift in the population at the site. At the same time, there is a considerable increase in *Ovis aries*, while *Capra hircus* remains are found in correspondingly high proportions. While the ratio of goat to sheep is unusually high at Tayinat (typically around 1:1), during FP6 it is dramatically higher than normal and may represent significantly different herding practices from those typically observed at the site during the Early Bronze or later Iron Age. The greater ratio of goat to sheep is unusual compared with other sites in the area, where sheep tend to outnumber goat.<sup>114</sup> Fish are also found in higher than normal quantities for the Iron Age during this earliest phase. The relative amount of fish represented during this phase is more reminiscent of the Early Bronze Age patterns than of later Iron Age phases.<sup>115</sup>

Significant differences can be observed between the Iron I remains and earlier finds from the EB IV. FP6 displays an increase in pig compared with FP7, but values are more comparable to those seen during the preceding FP8 (both FP7 and FP8 are EB IVB).<sup>116</sup> This value is lower than that observed for many Late

<sup>114</sup>Late Bronze Age Ugarit: Vila 2008, 170–71; Late Bronze Age Tell Atchana: Çakırlar and Rossel 2010, table 12.1; Late Bronze–Iron I Tell Afis: Wilkens 1998, table 2. Other sites are less conclusive, with similar numbers of identified sheep and goat; Tell Tweini: Linseele 2010, table 1; Kinet Höyük: Ikram 2003, fig. 2.

<sup>115</sup>Welton et al. 2011, figs. 14, 15.

<sup>116</sup>Welton et al. 2011, figs. 14, 15.

Bronze–Iron I sites in the region.<sup>117</sup> Furthermore, in contrast to other sites, where pig consumption appears to increase from the Late Bronze to the Iron I, this represents a substantial decrease from the published amounts of pig represented in Late Bronze Age levels at Tell Atchana (Alalakh), where pig forms more than 17% of the faunal assemblage.<sup>118</sup> There is also an increase in fish compared with FP7, but again values are more in keeping with those seen for FP8.<sup>119</sup>

#### *Archaeobotanical Remains*

TAP has conducted systematic recovery and analysis of archaeobotanical samples since excavations began in 2004, with more than 1,000 soil samples floated and processed to date.<sup>120</sup>

The heavy fraction is sorted in the field, allowing for any charred material that did not float to be collected, as well as microfauna, diagnostic pottery sherds, and other occasional small finds. Sixty-seven Iron I samples have been analyzed from Field 1, yielding a total of 6,237 seed and fruit remains, classified according to 120 analytical categories. Archaeobotanical results from Tell Atchana (Alalakh)<sup>121</sup> have been amalgamated with the present study to facilitate analysis of diachronic changes in crop and wild plant assemblages during the transition from the Late Bronze to the Iron Age. Crop remains from the two sites were analyzed according to their ubiquity scores and percentages. Redundancy analysis (RDA) was performed with Canoco 5 statistical analysis software to test for temporal variations among the wild plant assemblages at both sites.<sup>122</sup>

<sup>117</sup> Although differences in recovery methods and quantification techniques make direct comparisons difficult. See: Sirkeci Höyük, Late Bronze–Iron I: ca. 10% in both periods; Vogler 1997. Tell Afis, Late Bronze: ca. 6%, Iron I: ca. 17–23%; Wilkens 1998, table 2. Ğindāris, Late Bronze/Iron I: ca. 8%, Iron Age: ca. 18%; Vila and Dalix 2004, 236. Other northern Levantine sites, however, have comparatively low levels of pig, ca. 1–2% of the faunal assemblage: Ugarit: Vila 2008, 170–71. Tell Tweini: Linseele 2010, table 1. Qatna: Vila and Dalix 2004, 236. Kamid el-Loz: Bökönyi 1990.

<sup>118</sup> Çakırlar and Rossel 2010, table 12.1. Pig increases from Late Bronze to Iron Age at Kinet Höyük, Tell Afis, and Ğindāris, for example; Vogler 1997; Wilkens 1998; Ikram 2003.

<sup>119</sup> Welton et al. 2011, figs. 14, 15.

<sup>120</sup> See also Capper 2012 for preliminary analysis of Tayinat archaeobotanical data.

<sup>121</sup> Çizer 2006; Riehl 2010a; Stirn 2013.

<sup>122</sup> RDA is a constrained form of principal components analysis that is used here to partition the variation in the species

Tayinat's Iron Age inhabitants continued cultivating the same crop repertoire exploited by the Late Bronze Age community at Tell Atchana (Alalakh) (online appx. on AJA Online, table 2).<sup>123</sup> Cereals comprise most crop finds in the Iron I. Free-threshing wheat (*Triticum aestivum/durum*) outnumbers other crop plants for all Iron I deposits, while a notable increase in ubiquity scores for two-rowed barley (*Hordeum vulgare*) is recognizable during FPs 6–5, in comparison to the preceding and succeeding phases. Emmer wheat (*Triticum dicoccum*) is a minor constituent of the crop spectrum, but the ubiquity scores of this crop plant are conspicuously higher during all Iron I phases at Tayinat than observed at Late Bronze Age Tell Atchana (Alalakh). Chaff remains of these three cereals are also well represented in Iron I deposits, with the seed-to-chaff ratio displaying the highest values recorded at both sites during FP6. Einkorn wheat (*Triticum monococcum*) appears minimally, as expected, since cultivation of this crop had already been abandoned in the Near East by the end of the Early Bronze Age.<sup>124</sup>

A range of leguminous crops, including bitter vetch (*Vicia ervilia*), an aggregate category of large-seeded pulses (*Vicia/Lathyrus*), lentil (*Lens culinaris*), grass pea (*Lathyrus sativus/cicera*), pea (*Pisum sativum*), and faba bean (*Vicia faba*), appear in much lower proportions than cereals. During the Iron I, large-seeded pulses from either the *Vicia* or *Lathyrus* genera seem to be the principal legume types cultivated. In comparison to Late Bronze Age levels of Tell Atchana (Alalakh), bitter vetch displays much lower ubiquity and proportions, while grass pea and related species become slightly more common during FP6. Lentil, which was a preferred legume crop in most of the Near East,<sup>125</sup> usually appears in lower proportions than bitter vetch and aggregate large-seeded pulses, and notably is nearly absent during the Iron II–III at Tayinat. Pea and faba bean were minor components of plant subsistence, possibly cultivated in small-scale garden plots.

representation within chronologically defined archaeological assemblages of wild plant species along two axes in relation to the plant species whose frequencies best differentiate among the assemblages, with time as an explanatory variable.

<sup>123</sup> For ubiquity scores from Tell Atchana, only the archaeobotanical data in Stirn 2013 has been used as this study displays better stratigraphic control over samples.

<sup>124</sup> Riehl 2009.

<sup>125</sup> Riehl 2009.

Flax (*Linum usitatissimum*), an important economic plant for its fiber and oil-providing seeds, appears infrequently in all phases analyzed at Tayinat. The best-preserved evidence has been recovered from Iron II–III levels, albeit always in low counts.

A variety of arboricultural fruits such as grape (*Vitis vinifera*), olive (*Olea europaea*), and fig (*Ficus carica*), which are typical crops for Mediterranean environments like that of Tayinat, are a stable component of the crop assemblage. All are fairly ubiquitous at Tell Atchana and Tayinat, and it should be noted that there is no indication that cultivation of any of these crops was abandoned during the transition from the Late Bronze to the Iron Age. Indeed, these fruit-bearing trees scored their highest Iron Age values, both in proportion and ubiquity, in FP6.

Other plants that might have been part of the diet were caper (*Capparis spinosa*) and fenugreek (*Trigonella foenum-graecum*), which were only recorded in FP6. Coriander (*Coriandrum sativum*), on the other hand, first appears in FP3, with more frequent occurrences documented in Iron II–III.

Four wild taxa, including ryegrass (*Lolium*), canary grass (*Phalaris*), aggregate clovers (*Melilotus/Trifolium*), and stinking chamomile (*Anthemis cotula*), comprise most non-crop finds at Tayinat, irrespective of period. These taxa are also frequently recorded in the wider region.<sup>126</sup> Ryegrass is by far the dominant genus and is well adapted to survive in arable fields because of its ability to mimic the crop cycle and seed shape. Some species of *Lolium* (e.g., *L. temulentum*) are noxious for human consumption if not a serious pest<sup>127</sup> and thus would have required careful hand-sorting before food preparation.

The clustering of the remaining wild taxa during the Late Bronze–Iron Age transition provides insight into paleoenvironmental conditions in the Amuq Plain. The RDA plot (fig. 25)<sup>128</sup> clearly separates both as-

semblages along the horizontal axis, which represents the most distinct variation found in the assemblage and accounts for 32% of the total variation. FP6 is separated most clearly from the preceding levels at Tell Atchana (Alalakh) and the succeeding phases at Tayinat. The Tayinat FP6 flora are characterized by the near-complete absence of a group of wild leguminous plants (*Prosopis farcta*, *Securigera*, *Coronilla*, *Scorpiurus*) that was common at Late Bronze Age Tell Atchana,<sup>129</sup> especially in Levels 5–4. Instead, taxa indicative of moisture-laden habitats (e.g., *Aeluropus cf. littoralis*, *Phleum*, *Cynodon dactylon*, *Scirpus maritimus*, *Eleocharis*, *Fimbristylis annua*) predominate in Tayinat FP6. Simultaneously, plants that thrive in open vegetation, such as *Chenopodium murale*, *Cichorium*, *Hordeum* spp., *Centaurea* type, and *Malva*, as well as taxa reflective of overgrazed conditions, such as *Verbascum* and *Ornithogalum/Muscari*, are fairly common during Tayinat FP6. The vertical axis in figure 25, which represents the second-most distinct variation in the plant assemblage, also further distinguishes FP6 from the later Iron I assemblages (FPs 5 and 4–3), which contain previously absent wild leguminous plants. The reincorporation of these taxa may reflect an expansion of the site's agricultural catchment area through the cultivation of new arable fields that likely were left uncultivated during FP6.

#### FIELD 4 INVESTIGATIONS

Excavations were conducted in Field 4, located on the western edge of the mound (see fig. 2), in 2006 and 2007. Portions of five squares were excavated, but Iron I levels were limited to square G3.34. Field 4 investigations were initiated with the aim of reexamining Trench T-5 of the Syrian-Hittite Expedition, which had uncovered a section of the Iron II–III fortification system.<sup>130</sup> The renewed investigations succeeded in isolating a series of earlier structures cut by the fortification wall, including the remains of a metal workshop dating to the Iron I. The complex can be divided into three rooms (fig. 26). The southern Room 1 contained a semicircular installation (G3.34:15) consisting of a mudbrick platform built on top of a layer of sherds,

abbreviations used for the wild plant species used in the figure can be found in the Archaeobotanical Database of Eastern Mediterranean and Near Eastern Sites ([www.ademnes.de/](http://www.ademnes.de/)).

<sup>129</sup> Stirn 2013.

<sup>130</sup> Haines 1971, 57–8; Osborne et al. (forthcoming).

<sup>126</sup> See Riehl 2010b for an overview of the evidence.

<sup>127</sup> Riehl 2010a.

<sup>128</sup> Figure 25 represents the ordination diagram of the redundancy analysis for the wild species community with time as an explanatory variable accounting for 32% of the total variation along the first ordination axis, shown with a red arrow (pseudo- $F = 1.4$ ,  $P = 0.2004$ ,  $n = 9999$  permutations). For clarity, the typical visual expression with arrows has been replaced with dots. Dots represent the linear change of species abundances across the diagram, in relation to the plant species whose abundances best differentiate among the archaeological assemblages. The

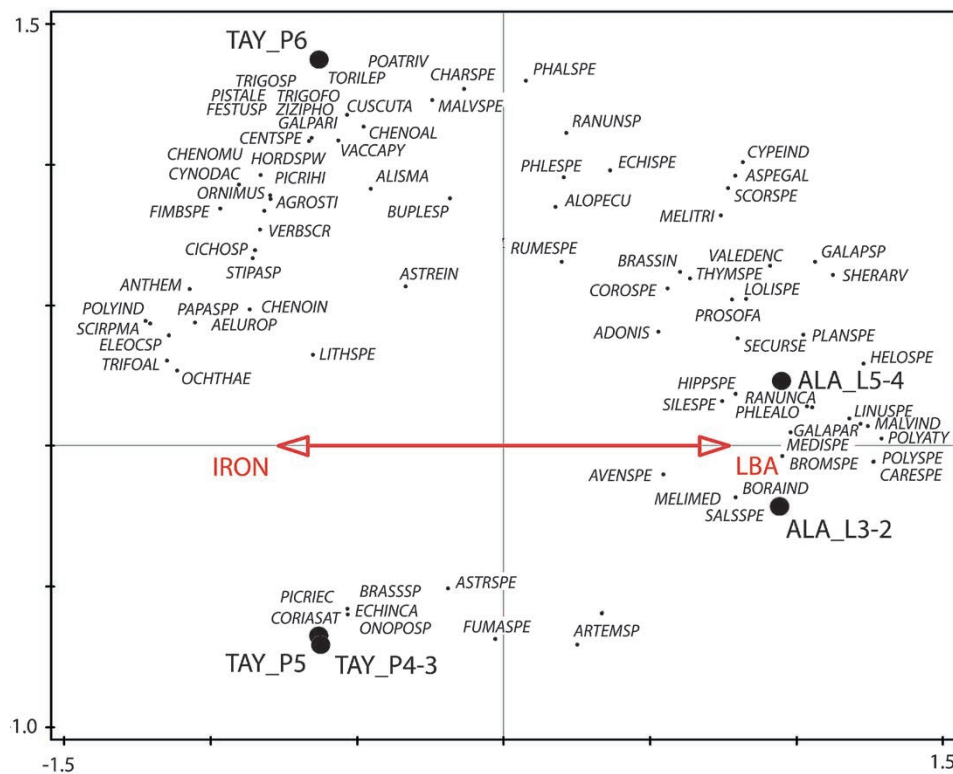

FIG. 25. RDA plot of combined datasets of wild plants from Late Bronze Age Tell Atchana (ALA\_L5-4 = Levels 5-4, ALA\_L3-2 = Levels 3-2) and Iron Age Tell Tayinat (TAY\_P6 = FP6, TAY\_P5 = FPS, TAY\_P4-3 = FP4-3; graphic by D. Karakaya).

bones, and stones. A layer of ash covered the installation, extended to the north and east, and ran up against the wall to the west (G3.34:17). In the northern Room 2, five ash deposits, each about 50 cm in diameter, formed an L-shaped pattern in the southwest corner of the room. In Room 3, the eastern half of which was disturbed by later building activity, several slag cakes were found in the southwest corner of the room. Significant amounts of slag, copper and iron fragments, tuyeres, and crucible fragments were recovered from each of the rooms. The workshop has been dated to the Iron I period (most likely the 11th century B.C.E.), based primarily on the associated ceramic assemblage, which is characterized by the presence of locally produced LH III C-style pottery.

#### *Archaeometallurgy*

Most of the finds from Field 4 are related to metallurgical production.<sup>131</sup> Ten iron and 12 copper artifacts of identifiable form were found in the metal workshop,

including weaponry (projectile points, armor scales), needles (fig. 27, no. 1), nails, jewelry (pins [see fig. 27, no. 2], a ring, and a fibula), and tools (see fig. 27, no. 3). Numerous unidentifiable iron and copper fragments were also recovered, and preliminary X-ray fluorescence (XRF) analysis on two fragments indicates that the copper was alloyed with high amounts of tin.<sup>132</sup>

Field 4 also produced more than 800 fragments of slag, including a number of slag cakes. XRF analysis of the slag indicates that both bronze and iron were being worked. Four of the slag samples analyzed were determined to relate to bronzeworking and two to ironworking.<sup>133</sup> The recovered slag cakes included hearth-bottom slag cakes associated with iron smithing. Two sizes of iron slag cakes were identified: (1) approximately 6 cm diameter, 1 cm thickness, with a concavo-convex shape; and (2) greater than 10 cm diameter, 3 cm thickness, with a plano-convex shape. Additionally, a significant quantity of flake hammer

<sup>131</sup> For further description, see Roames 2011.

<sup>132</sup> Roames 2011, table 1.

<sup>133</sup> Roames 2011, table 1.



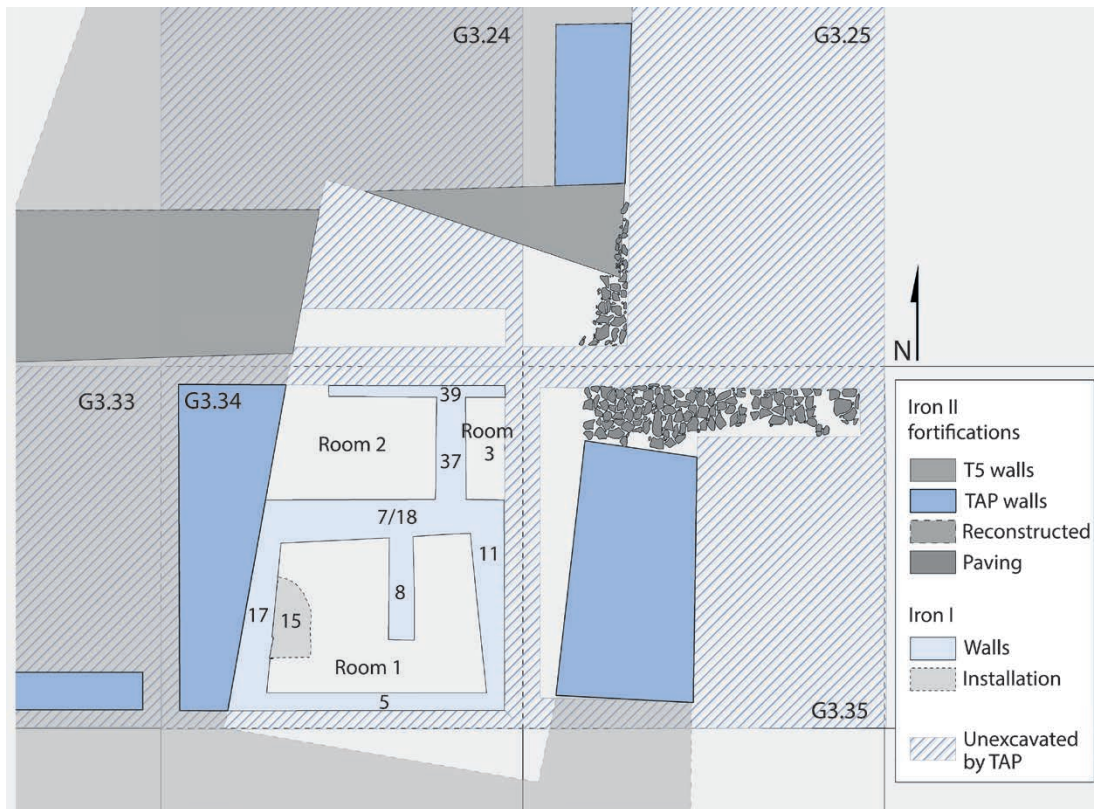

FIG. 26. Plan of Field 4 architecture. T5 walls represent those uncovered by the Syrian-Hittite Expedition in 1938. TAP walls represent those excavated by the Tayinat Archaeological Project in 2006–2007. All Iron I walls were excavated by TAP (graphic by L. Welton).

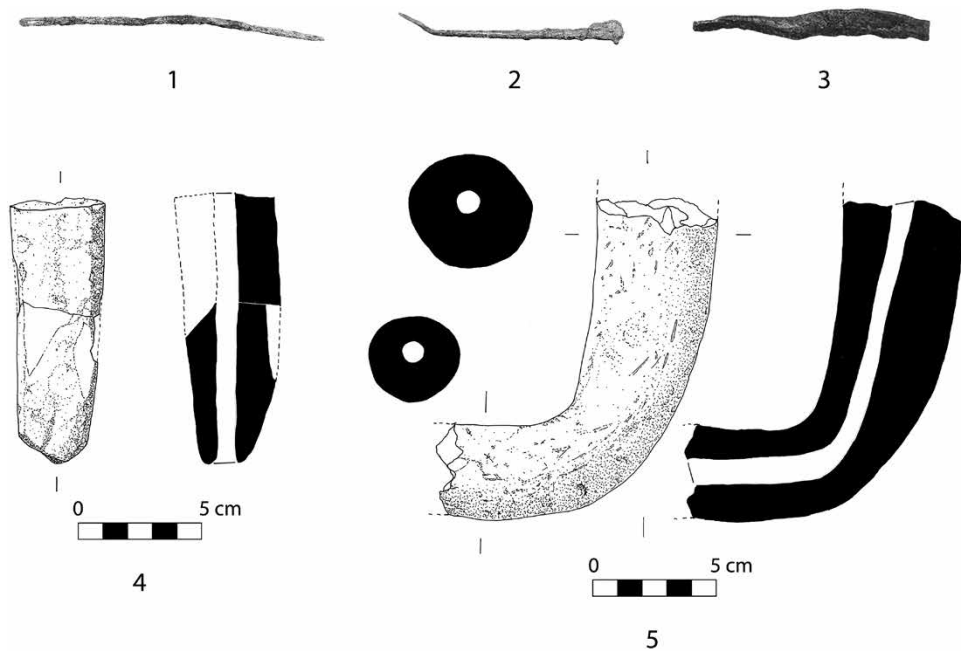

FIG. 27. Evidence of metallurgical production at Tayinat: 1, needle; 2, pin; 3, tool; 4, 5, tuyeres; 1, TT-762; 2, TT-772; 3, TT-494; 4, TT-465,467; 5, TT-495 (S. Harrison and A. Harrison; drawings by F. Haughey).

scale from iron smithing was recovered from Room 2. Preliminary analysis of the slag indicates that iron smithing, copper smelting, and copper alloying all occurred in the workshop and that both iron and bronze were worked in all three rooms.

Approximately 100 tuyere fragments were recovered and fall into two types based on their cross-sections: round (see fig. 27, no. 5) and square (see fig. 27, no. 4). Bore holes generally measure 0.6–1.0 cm, unless the back end is preserved, in which case the inner diameter starts at approximately 2 cm and tapers down. Outer diameters are mostly about 2.5–5 cm but can reach as much as 8 cm. Square tuyeres appear to have been favored in workshops discovered at Tell Beth-Shemesh (Israel; see fig. 1[43]) and Tell Hammeh (Jordan; see fig. 1[40]),<sup>134</sup> but square tuyeres have been found along with round ones at Tell es-Safi (Israel; see fig. 1[44]).<sup>135</sup> The longest preserved tuyere, at approximately 15 cm, was elbow-shaped (see fig. 27, no. 5).<sup>136</sup> Refractory materials identified in Field 4 also include a variety of both crucible and furnace fragments. These groups were often difficult to distinguish, but examples of complete rims with slag adhering to their interiors were interpreted as evidence for crucibles.

These preliminary results imply the existence of a non-specialized metal workshop involved in the production of both iron and copper products. Iron smithing occurred along with the melting and mixing of copper and tin, and the variety of artifacts recovered indicates that both utilitarian and prestige goods were being made from both metals.

## DISCUSSION

Tayinat's Iron I sequence in Field 1 (FPs 6–3) can be anchored to a more precise absolute chronology as a result of an extensive program of radiocarbon dating (fig. 28)<sup>137</sup> and can be subdivided into four discrete phases. The earliest phase coincides with FP6c. Although currently based on a single radiocarbon date, the stratigraphic, artifactual, and radiocarbon evidence suggest that FP6c should be dated to the mid 12th cen-

<sup>134</sup> Veldhuijzen 2009.

<sup>135</sup> Eliyahu-Behar et al. 2012a, 261.

<sup>136</sup> Similar bent tuyeres are known from the Late Bronze–Iron I southern Levant and Late Bronze Age Cyprus at Politiko-Phorades; Hein et al. 2007, 143, fig. 4; Eliyahu-Behar et al. 2012b, 1274, fig. 35.4.

<sup>137</sup> For primary radiocarbon data, see Manning et al. (forthcoming).

tury B.C.E. This corresponds well with the ceramic assemblage, which demonstrates strong continuity with preceding Late Bronze Age potting traditions, particularly in the Plain Ware corpus. Similar continuity in ceramic production extending through the 12th century has also been observed at numerous other sites in the region, particularly in southeastern Anatolia.<sup>138</sup> Locally produced LH IIIC-style pottery, meanwhile, is rare to almost absent in this earliest Iron I phase.

The second phase coincides with FP6b, which marks the appearance and expanding production of local LH IIIC-style pottery, and should be dated to the late 12th–early 11th centuries B.C.E.; this phase also witnessed the earliest structural remains in Field 1. A similar introduction and proliferation of locally produced Aegeanizing materials have been observed at other Levantine sites.<sup>139</sup> It is also during this phase that evidence of textile production becomes more frequent in Field 1. The third phase, represented by FPs 6a–5, dates to the 11th century B.C.E. and corresponds to the peak of local production of Aegeanizing pottery. The metal workshop in Field 4 most likely dates to this phase.

The fourth phase, represented by FPs 4–3, extends from the late 11th through the early to mid 10th centuries B.C.E. and is characterized by a gradual decline in the presence of Aegean-style pottery and the appearance in small quantities of ceramic traditions that will later characterize the Iron II.<sup>140</sup> The terminal phase of the Iron I (Iron IC, mid to late 10th century B.C.E.) is not represented in the Field 1 sequence, having been presumably removed during the later Iron II building activities associated with the construction of Temple II. Thus far, the TAP excavations have encountered

<sup>138</sup> Karkamiš: Pizzimenti and Zaina 2016; Giacosa and Zaina (forthcoming); Tarsus: Goldman 1956, 203–5; Yalçın 2013, 201–2; Tille Höyük: Summers 2013, 317; Malatya: Manuelli 2013, 380; Tell Afis: Venturi 2011, 145; 2013, 234.

<sup>139</sup> Tell Afis: Venturi 2010, 5; Çatal Höyük: Pucci 2013, 97; (forthcoming, 147, 235). Note that coastal sites often see a slightly earlier (early 12th century) introduction of locally produced Aegeanizing ceramics; Tell Kazel: Jung 2006, 207–10; 2007, 565–67; Ras Ibn Hani: du Pied 2008, 169–70; 2011, 225–26.

<sup>140</sup> E.g., mineral-tempered cooking ware, which becomes more common in the Iron II period, appears in small quantities in FP3 contexts. Red-Slipped and Burnished Ware, a diagnostic feature of the Iron II–III, also appears in a rudimentary form in very small quantities in FP3.

Absolute Chronology (B.C.E.)	Tayinat Archaeological Sequence		Chicago Excavations	Tayinat History (after Weeden 2013)	Mazzoni Periodization
	Field 1	Field 4			
			BP2	Qalparunda II Sapalulme (+Lubarna?)	Iron IIA
900			BP1	Halparuntiya I Suppiluliuma I Manana	
	FP3 FP4			Taita II	Iron IC
1000	FP5a FP5b			Taita I	
	FP6a	Workshop			Iron IB
1100	FP6b				
	FP6c				Iron IA
1200					

FIG. 28. Chronological context of the Iron I levels at Tell Tayinat with gray areas indicating the four subdivisions discussed in the text. Chicago Excavations are those of the Oriental Institute's Syrian-Hittite Expedition. BP = building period, as defined in Haines 1971.

only traces of this phase, primarily in Field 2 to the north, between the foundations of Building XIV.

The four-phase Iron I sequence delineated in Field 1 correlates well with sequences uncovered at other sites in the region (fig. 29). In the Amuq Plain, for example, the Syrian-Hittite Expedition's excavations at Çatal Höyük identified four architectural phases dating to the Iron I, best preserved in Area I (Levels 10–7), but also encountered in Area II (Levels 11–9), and in very limited exposures in Areas III–VI.<sup>141</sup> The excavations at Tell Judaidah (squares D–F 7–10) identified three discrete phases, Levels 11–9.<sup>142</sup> Elsewhere in the region, Tell Afis has produced three major Iron I strata, some of which can be further subdivided. These include Phase Va, a transitional period that dates to

<sup>141</sup> Haines 1971, 5, 13–14, 17–24; Pucci 2013, 97–9; (forthcoming, 27–34, 71–80, 95–8, 118–25); in Pucci (forthcoming), Area I, Level 10 = Amuq Phase N Beginning; Area I, Level 9–8 = Amuq Phase N Middle; and Area I, Level 7 = Amuq Phase N Late (see fig. 29).

<sup>142</sup> Haines 1971, 27–8.

the early 12th century B.C.E.; Phase IV, which can be further delineated into three subphases; and Phase III, with four subphases.<sup>143</sup> In contrast to the Tayinat sequence, however, the Iron I levels at Afis form part of a continuous sequence spanning the LB II/Early Iron Age transition and continuing through to the Iron IC. Stratified sequences spanning the LB II–Iron I have also been excavated at Ras el-Bassit and Ras Ibn Hani, and at Tell Kazel,<sup>144</sup> with the Early Iron I levels at the latter two sites producing significant quantities of LH IIIC pottery.

The emerging view of Early Iron Age northern Levantine settlement points to the existence of a transitional period dating to the early to mid 12th century B.C.E. This transitional phase is represented by Tayinat FP6c, Tell Afis Phase Va, Tarsus-Gözlükule LB IIB,

<sup>143</sup> Phase Va: Venturi 2007, 137–39, 269; 2011, 144; Phase IV: Venturi 2007, 140–48; Phase III: Venturi 2007, 149–61, 301.

<sup>144</sup> Ras el-Bassit and Ras Ibn Hani: du Piéd 2008, 2011. Tell Kazel: Capet 2003; Badre 2006.

Absolute Chronology (B.C.E.)	Tayinat Field 1	Çatal Höyük	Tell Afis	Ras Ibn Hani		Tell Tweini	Tell Kazel		Tell Arqa	Sarepta	Tarsus	Kilise Tepe
				Southern Complex	Northern Complex		Area II	Area IV				
950	FP4,3											
1000	FP5b-a	Amuq Phase N Middle	III	Upper Level	Upper Level	VII B (Chantier A: 6E-F,				D		
1050	FP6a					Chantier B: 7B-C)					EI A	
1100	FP6b	Amuq Phase N Beginning	IV		Lower Level	VII A	?	?		E		Ile
1150	FP6c	Amuq Phase M Late	Va	Lower Level	2007 evidence	(Chantier A: 6G-H, Chantier B: 7A)	Level 5	Level 4-3		F		
	?						Level 6 upper	Level 5 upper	Level 11A	G1		
1200			VI/Vb				abandonment?	abandonment?	Level 11B		LB IIB	IId
1250		Amuq Phase M Middle				VIII B (Chantier A: 7A-C, Chantier B: 8B)	Level 6 lower	Level 5 lower	Level 11C			IIC
1300			VII					Level 6 upper	hiatus?		LB IIA	Ila-b

FIG. 29. Comparative stratigraphic chart for notable Iron I sites in southeastern Anatolia and the northern Levant. Gray areas indicate the four subdivisions of the Iron I at Tell Tayinat as discussed in the text.

Kilise Tepe Level IId, Kinet Höyük Level 13.2, Sarepta Stratum F, and the transitional Late Bronze/Iron I phases at Ras Ibn Hani (Southern Complex, Lower Level).<sup>145</sup> This phase may immediately postdate the transitional LB II/Iron I assemblages represented at the coastal sites of Tell Kazel (Areas IV:5 upper and II:6 upper), Tell Arqa (sublevel 11A), and Sarepta (Stratum G1).<sup>146</sup> The succeeding Iron I levels at Tell Kazel (Areas IV:4-3 and II:5) may be partially contemporary with this transitional phase in the early to mid 12th century B.C.E.

Assemblages comparable to those observed at Tayinat in its second and third phases (FPs 6b-5) occur at Tell Afis (Phase IV-III), Tarsus (LB IIB), Kilise Tepe (Level IIE), Sarepta (Stratum E), Ras el-Bassit, and Ras Ibn Hani (Northern Complex, Lower Level;

Upper Level).<sup>147</sup> Tell Kazel (Areas II:5 and IV:4-3), Tell Tweini (Levels VIIA-B), and Kinet Höyük (Level 12) are also likely contemporary with these second and third Iron I phases.<sup>148</sup> Assemblages corresponding to the fourth phase of the Iron I at Tayinat, as represented by FPs 4-3, appear less widely known but may be represented at Tell Afis (Phase III) and Ras Ibn Hani (Upper Levels of both the Southern and Northern Complexes), and at least partially contemporary assemblages occur at Tell Tweini (Level VII B), Sarepta (the earlier part of Stratum D), and Kilise Tepe (Level IIE).<sup>149</sup>

<sup>145</sup> Tell Afis: Venturi 2007, 137-39, 269; 2010, 4; 2011, 144. Tarsus-Gözlükule: Goldman 1956, 50, 58-9; Ünlü 2005, 145-46; Yalçın 2013, 200-2. Kilise Tepe: Hansen and Postgate 1999, 112-13; Postgate 2008, 170-71; Bouthillier et al. 2014, 106, 125-26, table 1. Kinet Höyük: Gates 2006, 302-4, 307. Sarepta: Anderson 1988, 82-9, 386-90; Khalifeh 1988, 102-13. Ras Ibn Hani: Material excavated in 2007 beneath the Lower Level of the Northern Complex is believed to be contemporary to the Lower Level of the Southern Complex and would also date to this transitional period (du Piéd 2008, 163; 2011, 219-20).

<sup>146</sup> Tell Kazel: Badre 2006, 69, 82-92. Tell Arqa: Charaf 2008, 83; 2011, 206. Sarepta: Anderson 1988, 76-82, 386-90.

<sup>147</sup> Tell Afis: Venturi 2007, 140-48, 271-94; 2010, 4-7; 2011, 144-48; 2013, 234. Tarsus: Goldman 1956, 50, 58-9; Ünlü 2005, 145-46; 2016; Gates 2011, 395-96; Yalçın 2013, 200-2. Kilise Tepe: Hansen and Postgate 1999, 112-17; Postgate 2008, 175-78; Bouthillier et al. 2014, table 1, 123-25. Sarepta: Anderson 1988, 89-97, 390-96; Khalifeh 1988, 113-24. Ras el-Bassit and Ras Ibn Hani: du Piéd 2008, 163; 2011, 220.

<sup>148</sup> Tell Kazel: Badre et al. 1990, 70-8; Capet 2003, 99-115; Badre 2006, 69. Tell Tweini: Bretschneider and Van Lerberghe 2010, 43-4, table 1; Vansteenhuyse and Bretschneider 2011, 190. Kinet Höyük: Gates 2006, 302-4; 2013b, 493-95.

<sup>149</sup> Tell Afis: Venturi 2007, 149-61, 271-94; 2010, 4-7; 2011, 144-48; 2013, 234. Ras Ibn Hani: du Piéd 2008, 163; 2011, 220. Tell Tweini: Bretschneider and Van Lerberghe 2010, 43-4, table 1. Sarepta: Anderson 1988, 97-108, 396-407; Khalifeh 1988, 125-39. Kilise Tepe: Hansen and Postgate 1999, 112-17;

## CONCLUSION

In a wide-ranging article about “the Philistines in the north,” Singer suggested that scholars studying the Early Iron Age northern Levant, unlike their colleagues to the south, are more “susceptible to interpretations emphasizing gradual local developments, rather than sudden changes.”<sup>150</sup> In light of his preference for the traditional Sea Peoples migration hypothesis,<sup>151</sup> Singer’s observation amounts to a criticism of interpretations that emphasize continuity and local development. Yet, in both regions, there exists compelling evidence for both continuity and change. Much of this difference in emphasis must be attributed to the diverging scholarly traditions of these two regions and the intellectual histories that have shaped their respective interpretive paradigms. However, rather than a weakness, we would argue that these divergent approaches have the ability to highlight differences in regional trajectories, breaking down an otherwise monolithic cultural phenomenon into more nuanced representations that more accurately reflect the remarkable variability that characterized local experiences.<sup>152</sup>

Scholarly assessments of Early Iron Age Tayinat mirror this diversity of interpretations. Characterizations of its material culture have consistently emphasized its intrusive, nonlocal nature,<sup>153</sup> while discussions of the textual evidence have highlighted the region’s political continuity, from the period of Late Bronze Age Hittite imperial control to the Neo-Hittite rump states of the Iron Age.<sup>154</sup> Yet the diverse spectrum of cultural links observed in Tayinat’s Early Iron Age levels clearly reflect a considerably more complex and more ambiguous cultural reality than has previously been acknowledged.

The ceramic assemblage and small finds in the Iron I levels at Tayinat collectively indicate continuity with preceding Late Bronze Age craft traditions while simultaneously signaling the introduction of new cultural innovations (e.g., LH IIIC-style pottery and

spool-shaped loomweights used for warp-weighted textile production). As we have seen, the LH IIIC-style pottery draws its best parallels from Cypriot and northern Levantine coastal sites.<sup>155</sup> Likewise, the evidence for textile production, in particular the cylindrical loomweights of unbaked clay, shows wide-ranging parallels throughout the eastern Mediterranean. Gray Wares are further indicative of geographically diverse connections in the eastern Mediterranean, possibly extending as far as northwestern Anatolia. Other potting traditions, meanwhile, such as the Plain Wares and some Local Painted Wares have closer parallels to the north and west, at sites such as Tarsus-Gözlükule and Kilise Tepe, and throughout large areas of south-eastern Anatolia. These traditions suggest close cultural connections with the former Hittite world and the continuation of earlier ceramic industries. Cooking wares, notably, also provide strong evidence (in both form and fabric) of continuity with local potting traditions from the preceding Late Bronze Age, as do the associated cooking installations. Conversely, the presence of Aegean-style cooking jugs, albeit limited in number thus far, hint at the simultaneous presence of nonlocal culinary practices.

Perhaps the most significant evidence of change was the shift of the central settlement from Tell Atchana (Alalakh), capital of the Late Bronze Age kingdom of Mukiš, to Tell Tayinat in the early 12th century B.C.E. Tayinat’s estimated size during this period (between 12 and 20 ha) would have made it one of the largest sites in the eastern Mediterranean during the Early Iron Age. Despite the limited extent of the Iron I settlement excavated thus far, the considerable size of the site, the evidence of functional differentiation (e.g., domestic vs. industrial), the remarkable diversity and range of material culture, and the presence of luxury raw materials such as gold, ivory, and carnelian, collectively point to a prosperous settlement with extensive interregional connections. The pottery and small finds confirm this view, demonstrating that Tayinat lay at the confluence of multiple cultural spheres, ranging from Cilicia and southeastern Anatolia to the north, inland Syria to the east, the Levantine coast to the south, and the Aegean world to the west.

Postgate 2008, 175–78; Bouthillier et al. 2014, table 1, 122–25.

<sup>150</sup> Singer 2012, 454 n. 13.

<sup>151</sup> Singer 2012, 456.

<sup>152</sup> Gilboa 2008; Gates 2010, 65.

<sup>153</sup> Harrison 2009b, 181–83, 187; 2010, 88–91; Yasur-Landau 2010, 161–63; Karageorghis 2011, 23; Singer 2012, 464–68; Sherratt 2013, 625–27; Galil 2014, 79–80; Younger 2016, 131–32.

<sup>154</sup> Harrison 2009a; 2010, 83–4, 91; Weeden 2013, 11; Younger 2016, 123–35.

<sup>155</sup> Whose ceramic traditions in this period are themselves often considered an amalgam of Cypriot, Aegean, and Levantine influences; Kling 1991, 182–83; Mountjoy 2005b, 209–10; 2010; Voskos and Knapp 2008, 668–69, 677–78.

Far from experiencing a period of cultural devolution and isolation, Early Iron Age Tayinat was engaged in wide-ranging cultural and economic interaction. These interactions fueled the growth of a vibrant community and contributed collectively to the distinctively local, and unique, cultural expression manifested at Tayinat during this period. This cultural and socioeconomic vibrancy would ultimately culminate in the royal city of Kunulua, capital of the Neo-Hittite kingdom of Patina, with its signature architectural and sculptural monuments.

Lynn Welton  
Department of Archaeology  
Durham University  
Durham DH1 3LE  
United Kingdom  
lynn.welton@utoronto.ca

Timothy Harrison  
Department of Near and Middle Eastern Civilizations  
University of Toronto  
Toronto, Ontario M5S 1C1  
Canada  
tim.harrison@utoronto.ca

Stephen Batiuk, stephen.batiuk@utoronto.ca  
Elif Ünlü, elif.unlu@boun.edu.tr  
Brian Janeway, bigedj@aol.com  
Doğa Karakaya,  
doga.karakaya@student.uni-tuebingen.de  
David Lipovitch, david.lipovitch@utoronto.ca  
David Lumb, david.lumb@mail.utoronto.ca  
James Roames, jrroames@yahoo.com

### Works Cited

- Akar, M. 2013. "The Late Bronze Age Fortress at Alalakh: Architecture and Identity in Mediterranean Exchange Systems." In *Across the Border: Late Bronze–Iron Age Relations Between Syria and Anatolia*, edited by K.A. Yener, 37–60. Leuven: Peeters.
- Allen, S.H. 1991. "Late Bronze Age Grey Wares in Cyprus." In *Cypriot Ceramics: Reading the Prehistoric Record*, edited by J.A. Barlow, D.L. Bolger, and B. Kling, 151–67. Philadelphia: University Museum of Archaeology and Anthropology.
- . 1994. "Trojan Grey Ware at Tel Miqne-Ekron." *BASOR* 293:39–51.
- Anderson, W.P. 1988. *Sarepta*. Vol. 1, *The Late Bronze and Iron Age Strata of Area II, Y: The University Museum of the University of Pennsylvania Excavations at Sarafand, Lebanon*. Beirut: Département des publications de l'Université libanaise.
- Arie, E. 2013. "The Late Bronze III and Iron I Pottery: Levels K-6, M-6, M-5, M-4 and H-9." In *Megiddo V: The 2004–2008 Seasons*. Vol. 2, edited by I. Finkelstein, D. Ussishkin, and E.H. Cline, 475–667. Winona Lake, Ind.: Eisenbrauns.
- Badre, L. 2006. "Tell Kazel-Simyra: A Contribution to a Relative Chronological History in the Eastern Mediterranean During the Late Bronze Age." *BASOR* 343:65–95.
- . 2011. "The Cooking Pot Tradition at Tell Kazel." In *On Cooking Pots, Drinking Cups, Loomweights and Ethnicity in Bronze Age Cyprus and Neighbouring Regions*, edited by V. Karageorghis and O. Kouka, 149–66. Nicosia: A.G. Leventis Foundation.
- Badre, L., E. Gubel, M. Al-Maqdissi, and H. Sader. 1990. "Tell Kazel, Syria: Excavations of the AUB Museum, 1985–1987. Preliminary Report." *Berytus* 38:10–124.
- Badre, L., M.-C. Boileau, R. Jung, and H. Mommsen. Appendix by M. Kerschner. 2005. "The Provenance of Aegean and Syrian-Type Pottery Found at Tell Kazel." *Ägypten und Levante* 15:15–47.
- Barone, R. 1976. *Anatomie comparée des mammifères domestiques*. Vol. 1, *Ostéologie*, fasc. 2, *Atlas*. Paris: Vigot Freres.
- Batiuk, S., T.P. Harrison, and L. Pavlish. 2005. "The Ta' yinat Survey, 1999–2002." In *The Amuq Valley Regional Projects*. Vol. 1, *Surveys in the Plain of Antioch and the Orontes Delta, Turkey, 1995–2002*, edited by K.A. Yener, 171–92. OIP 131. Chicago: Oriental Institute, University of Chicago.
- Becks, R. 2003. "Troia VII: Transition from the Late Bronze to the Early Iron Age." In *Identifying Changes: The Transition from Bronze to Iron Ages in Anatolia and Its Neighbouring Regions*, edited by B. Fischer, H. Genz, E. Jean, and K. Köroğlu, 41–53. Istanbul: Ege Yayınları.
- Ben-Shlomo, D. 2006. "Selected Objects." With contributions by A. Golani and I. Milevski. In *Tel Miqne-Ekron Excavations 1995–1996: Field INE East Slope, Iron Age I (Early Philistine Period)*, edited by M.W. Meehl, T. Dothan, and S. Gitin, 189–206. Jerusalem: W.F. Albright Institute of Archaeological Research and Institute of Archaeology, Hebrew University of Jerusalem.
- Boessneck, J. 1963. "Osteological Differences Between Sheep (*Ovis aries* Linné) and Goat (*Capra hircus* Linné)." In *Science in Archaeology*, edited by D. Brothwell and E.S. Higgs, 331–58. New York: Praeger.
- Boessneck, J., H.H. Müller, and M. Teichert. 1964. "Osteologische Unterscheidungsmerkmale zwischen Schaf (*Ovis aries* Linné) und Ziege (*Capra hircus* Linné)." *Kühn-Archiv* 78:1–129.
- Boileau, M.-C., L. Badre, E. Capet, R. Jung, and H. Mommsen. 2010. "Foreign Ceramic Tradition, Local Clays: The Handmade Burnished Ware of Tell Kazel (Syria)." *JAS* 37:1678–689.
- Bökönyi, S. 1990. *Kamid el-Loz*. Vol. 12, *Tierhaltung und Jagd*. Bonn: Dr. Rudolf Habelt.
- Bounni, A., J. Lagarce, E. Lagarce, N. Saliby, and L. Badre. 1979. "Rapport préliminaire sur la troisième campagne de fouilles (1977) à Ibn Hani (Syrie)." *Syria* 56:217–91.
- Bounni, A., E. Lagarce, and J. Lagarce. 1998. *Ras Ibn Hani*. Vol. 1, *Le Palais Nord du Bronze récent: Fouilles 1979–1995, synthèse préliminaire*. Beirut: Bibliothèque Archéologique et Historique.

- Bouthillier, C., et al. 2014. "Further Work at Kilise Tepe, 2007–2011: Refining the Bronze to Iron Age Transition." *AnatSt* 64:94–161.
- Braidwood, R.J., and L.S. Braidwood. 1960. *Excavations in the Plain of Antioch*. Vol. 1, *The Earlier Assemblages, Phases A–J*. OIP 61. Chicago: University of Chicago Press.
- Bretschneider, J., and K. Van Lerberghe. 2010. "Tell Tweini à travers les millénaires: L'histoire et l'archéologie." In *Tell Tweini: Onze campagnes de fouilles syro-belges (1999–2010)*, edited by M. al-Maqdissi, K. Van Lerberghe, J. Bretschneider, and M. Badawi, 15–76. Damascus: Ministère de la Culture, Direction Générale des Antiquités et des Musées.
- Bretschneider, J., G. Jans, and A.-S. Van Vyve. 2010. "Les fouilles du Chantier A en 2009 et 2010." In *Tell Tweini: Onze campagnes de fouilles syro-belges (1999–2010)*, edited by M. al-Maqdissi, K. Van Lerberghe, J. Bretschneider, and M. Badawi, 131–46. Damascus: Ministère de la Culture, Direction Générale des Antiquités et des Musées.
- Broodbank, C. 2013. *The Making of the Middle Sea: A History of the Mediterranean from the Beginning to the Emergence of the Classical World*. London: Thames and Hudson.
- Bryce, T.R. 1992. "The Role of Telepinu, the Priest in the Hittite Kingdom." *Hethitica* 11:5–18.
- . 1998. *The Kingdom of the Hittites*. Oxford: Oxford University Press.
- Çakırlar, C., and S. Rossel. 2010. "Faunal Remains from the 2003–2004 Excavations at Tell Atchana." In *Tell Atchana, Ancient Alalakh*. Vol. 1, *The 2003–2004 Seasons*, edited by K.A. Yener, 141–46. Istanbul: Koç Üniversitesi Yayınları.
- Capet, E. 2003. "Tell Kazel (Syrie): Rapport préliminaire sur les 9e–17e campagnes des fouilles (1993–2001) du Musée de l'Université Américaine de Beyrouth. Chantier II." *Berytus* 47:63–121.
- . 2008. "Les peuples des céramiques 'barbares' à Tell Kazel, Syrie." *Scripta Mediterranea* 27–28:187–207.
- Capet, E., and E. Gubel. 2000. "Tell Kazel: Six Centuries of Iron Age Occupation (c. 1200–612 B.C.)." In *Essays on Syria in the Iron Age*, edited by G. Bunnens, 425–57. Ancient Near Eastern Studies Suppl. 7. Leuven: Peeters.
- Capper, M.M. 2012. "Urban Subsistence in the Bronze and Iron Ages: The Palaeoethnobotany of Tell Tayinat, Turkey." M.A. thesis, Simon Fraser University.
- Cecchini, S.M. 2000. "The Textile Industry in Northern Syria During the Iron Age According to the Evidence of the Tell Afis Excavations." In *Essays on Syria in the Iron Age*, edited by G. Bunnens, 211–33. Ancient Near Eastern Studies Suppl. 7. Leuven: Peeters.
- . 2011. "Loomweights and the Textile Industry in North Syria in the Early Iron Age." In *On Cooking Pots, Drinking Cups, Loomweights and Ethnicity in Bronze Age Cyprus and Neighbouring Regions*, edited by V. Karageorghis and O. Kouka, 195–202. Nicosia: A.G. Leventis Foundation.
- Charaf, H. 2008. "New Light on the End of the Late Bronze Age at Tell Arqa." In *Inside the Levantine Maze: Archaeological and Historical Studies Presented to Jean-Paul Thalmann on the Occasion of His Sixtieth Birthday*, edited by H. Charaf, 70–98. Archaeology and History in the Lebanon 26–27. Beirut: Lebanese British Friends of the National Museum.
- . 2011. "Over the Hills and Far Away: Handmade Burnished Ware and Mycenaean Cooking Pots at Tell Arqa, Lebanon." In *On Cooking Pots, Drinking Cups, Loomweights and Ethnicity in Bronze Age Cyprus and Neighbouring Regions*, edited by V. Karageorghis and O. Kouka, 203–18. Nicosia: A.G. Leventis Foundation.
- Çizer, Ö. 2006. "Archaeobotanical Macro Remains from Late Bronze Age Kinet Höyük and Tell Atchana (Alalakh) in Southern Turkey: Economical and Environmental Considerations." M.A. thesis, University of Tübingen.
- Cooper, L. 2006. "The Pottery from Tell 'Acharneh, Part 1: Typological Considerations and Dating According to Excavated Areas in the Upper and Lower Towns, 1998–2002." In *Tell 'Acharneh 1998–2004: Preliminary Reports on Excavation Campaigns and Study Season*, edited by M. Fortin, 140–90. Subartu 18. Turnhout, Belgium: Brepols.
- Courbin, P. 1986. "Bassit." *Syria* 63(3/4):175–220.
- Dinçol, B., A. Dinçol, J.D. Hawkins, H. Peker, and A. Öztan. 2015. "Two New Inscribed Storm-God Stelae from Arsuz (İskanderun): ARSUZ 1 and 2." *AnatSt* 65:59–77.
- Dornemann, R. 2003. *Tell Qarqur: Iron I Sites in the North-Central Highlands of Palestine*. AASOR 56. Boston: American Schools of Oriental Research.
- Dothan, T. 1982. *The Philistines and Their Material Culture*. New Haven: Yale University Press.
- Dothan, T., and M. Dothan. 1992. *People of the Sea: The Search for the Philistines*. New York: MacMillan.
- Dothan, T., and A. Zukerman. 2004. "A Preliminary Study of the Mycenaean IIIC:1 Pottery Assemblages from Tel Miqne-Ekron and Ashdod." *BASOR* 333:1–54.
- du Piêd, L. 2008. "The Early Iron Age in the Northern Levant: Continuity and Change in the Pottery Assemblages from Ras el-Bassit and Ras Ibn Hani." *Scripta Mediterranea* 27–28:161–85.
- . 2011. "Early Iron Age Society in the Northern Levant: Architecture, Pottery and Finds." In *On Cooking Pots, Drinking Cups, Loomweights and Ethnicity in Bronze Age Cyprus and Neighbouring Regions*, edited by V. Karageorghis and O. Kouka, 219–36. Nicosia: A.G. Leventis Foundation.
- Dupré, S. 1983. *Porsuk*. Vol. 1, *La céramique de l'âge du Bronze et de l'âge du Fer*. Editions Recherche sur les civilisations 20. Paris: Institut français d'études anatoliennes.
- Eliyahu-Behar, A., N. Yahalom-Mack, S. Shilstein, A. Zukerman, C. Shafer-Elliott, A.M. Maeir, E. Boaretto, I. Finkelstein, and S. Weiner. 2012a. "Iron and Bronze Production in Iron Age IIA Philistia: New Evidence from Tell es-Safi/Gath, Israel." *JAS* 39:255–67.
- Eliyahu-Behar, A., N. Yahalom-Mack, Y. Gadot, and I. Finkelstein. 2012b. "Metalworking in Area K: A Reevaluation." In *Megiddo*. Vol. 5, *The 2004–2008 Seasons*, edited by I. Finkelstein, D. Ussishkin, and E.H. Cline, 1271–284. Wivona Lake, Ind.: Eisenbrauns.
- Evely, D., ed. 2006. *Lefkandi*. Vol. 4, *The Bronze Age: The Late Helladic IIIC Settlement at Xeropolis*. British School at Athens Suppl. 39. London: British School at Athens.

- French, E.B. 1975. "A Reassessment of the Mycenaean Pottery at Tarsus." *AnatSt* 25:53–75.
- Furumark, A. 1941a. *The Mycenaean Pottery: Analysis and Classification*. Stockholm: Pettersons.
- . 1941b. *The Chronology of Mycenaean Pottery*. Stockholm: Svenska Institut I.
- Galil, G. 2014. "A Concise History of Palistin / Patin / Unqi / 'mq in the 11th–9th Centuries BC." *Semitica* 56:75–104.
- Garstang, J. 1953. *Prehistoric Mersin: Yümük Tepe in Southern Turkey. The Neilson Expedition in Cilicia*. Oxford: Clarendon.
- Gates, M.-H. 2001. "Potmarks at Kinet Höyük and the Hittite Ceramic Industry." In *La Cilicie: Espaces et pouvoirs locaux (2e millénaire av. J.-C.–4e siècle ap. J.-C.)*, edited by E. Jean, A.M. Dinçol, and S. Durugönül, 137–57. Istanbul: Institut français d'études anatoliennes-Georges Dumézil.
- . 2006. "Dating the Hittite Levels at Kinet Höyük: A Revised Chronology." In *Structuring and Dating in Hittite Archaeology*, edited by D.P. Mielke, J. Seeher, and U.-D. Schoop, 293–309. Byzas 4. Istanbul: Ege Yayınları.
- . 2010. "Potters and Consumers in Cilicia and the Amuq During the 'Age of Transformations' (13th–10th Centuries BC)." In *Societies in Transition: Evolutionary Processes in the Northern Levant Between Late Bronze Age II and Early Iron Age*, edited by F. Venturi, 65–81. Bologna: CLUEB.
- . 2011. "Southern and Southeastern Anatolia in the Late Bronze Age." In *The Oxford Handbook of Ancient Anatolia, 10,000–323 B.C.E.*, edited by S.R. Steadman and G. McMahon, 393–412. Oxford: Oxford University Press.
- . 2013a. "From Late Bronze to Iron Age on Syria's Northwest Frontier: Cilicia and the Amuq." In *Syrian Archaeology in Perspective: Celebrating 20 Years of Excavations at Tell Afis*, edited by S. Mazzoni and S. Soldi, 95–116. Florence: Edizioni ETS.
- . 2013b. "Early Iron Age Newcomers at Kinet Höyük, Eastern Cilicia." In *The Philistines and Other "Sea Peoples" in Text and Archaeology*, edited by A.E. Killebrew and G. Lehmann, 485–508. *Archaeology and Biblical Studies* 15. Atlanta, Ga.: Society of Biblical Literature.
- Genz, H. 2003. "The Early Iron Age in Central Anatolia." In *Identifying Changes: The Transition from Bronze to Iron Ages in Anatolia and Its Neighbouring Regions*, edited by B. Fischer, H. Genz, E. Jean, and K. Köroğlu, 179–89. Istanbul: Ege Yayınları.
- . 2005. "Thoughts on the Origin of the Iron Age Pottery Traditions in Central Anatolia." In *Anatolian Iron Ages 5*, edited by A. Çilingiroğlu and G. Darbyshire, 75–84. London: British Institute at Ankara.
- Giacosa, G., and F. Zaina. Forthcoming. "Changing Patterns in the Earlier Iron Age Material Culture from Karkemish." In *Formation, Organization and Development of Iron Age Societies: A Comparative View*, edited by A. Sollee and V. Van Exel. Vienna: Austrian Academy of Sciences.
- Gilboa, A. 2008. "Fragmenting the Sea Peoples, with an Emphasis on Cyprus, Syria and Egypt: A Tel Dor Perspective." *Scripta Mediterranea* 27–28:209–44.
- Golani, A. 2009. "Metallic and Non-Metallic Jewelry." In *Excavations at Tel Beth-Shean, 1989–1996*. Vol. 3, *The 13th–11th Century BCE Strata in Areas N and S*, edited by N. Panitz-Cohen and A. Mazar, 612–33. Jerusalem: Israel Exploration Society and Institute of Archaeology, Hebrew University of Jerusalem.
- Golani, A., and D. Ben-Shlomo. 2005. "The Jewelry from Areas H and K." In *Ashdod*. Vol. 6, *Excavations of Areas H and K (1968–1969)*, edited by M. Dothan and D. Ben-Shlomo, 247–64. Israel Antiquities Authority Reports 24. Jerusalem: Israel Antiquities Authority.
- Goldman, H. 1956. *Excavations at Gözlü Kule, Tarsus*. Vol. 2, *From the Neolithic Through the Bronze Age*. Princeton: Princeton University Press.
- Gonnella, J., W. Khayyata, and K. Kohlmeyer. 2005. *Die Zitadelle von Aleppo und der Tempel des Wettergottes*. Münster: Rhema.
- Güterbock, H.G. 1967. *Siegel aus Boğazköy*. Vol. 1, *Teil, Die Königssiegel der Grabungen bis 1938*. Osnabrück: Biblio-Verlag.
- . 1992. "Survival of the Hittite Dynasty." In *The Crisis Years: The Twelfth Century B.C.*, edited by W.A. Ward and M.S. Joukowsky, 53–5. Dubuque, Iowa: Kendall/Hunt.
- Haines, R.C. 1971. *Excavations in the Plain of Antioch*. Vol. 2, *The Structural Remains of the Later Phases, Chatal Hüyük, Tell al-Judaidah and Tell Ta'yinat*. Chicago: University of Chicago Press.
- Hansen, C., and N. Postgate. 1999. "The Bronze to Iron Age Transition at Kilise Tepe." *AnatSt* 49:111–21.
- . 2007. "Pottery from Level III–II." In *Excavations at Kilise Tepe, 1994–1998: From Bronze Age to Byzantine in Western Cilicia*, edited by N. Postgate and D. Thomas, 329–70. London: British Institute at Ankara.
- Harrison, T.P. 2009a. "Lifting the Veil on a 'Dark Age': Ta'yinat and the North Orontes Valley During the Early Iron Age." In *Exploring the Longue Durée: Essays in Honor of Lawrence E. Stager*, edited by D. Schloen, 171–84. Wivona Lake, Ind.: Eisenbrauns.
- . 2009b. "Neo-Hittites in the 'Land of Palistin': Renewed Investigations at Tell Ta'yinat on the Plain of Antioch." *NEA* 72(4):174–89.
- . 2010. "The Late Bronze/Early Iron Age Transition in the Northern Orontes Valley." In *Societies in Transition: Evolutionary Processes in the Northern Levant Between Late Bronze Age II and Early Iron Age*, edited by F. Venturi, 83–102. Bologna: CLUEB.
- . 2013. "Tayinat in the Early Iron Age." In *Across the Border: Late Bronze–Iron Age Relations Between Syria and Anatolia*, edited by K.A. Yener, 61–88. Leuven: Peeters.
- Hawkins, J.D. 1979. "The Hieroglyphic Luwian Stelae of Mearde-Sheizar." In *Florilegium Anatolicum: Mélanges offerts à Emmanuel Laroche*, edited by E. Akurgal, 145–56. Paris: Éditions de Boccard.
- . 1988. "Kuzi-Teşub and the 'Great Kings' of Karkamiş." *AnatSt* 38:99–108.
- . 1995. "'Great Kings' and 'Country-Lords' at Malatya and Karkamiş." In *Studio Historiae Ardens: Ancient Near Eastern Studies Presented to Philo H.J. Houwink ten Cate on the Occasion of His 65th Birthday*, edited by T. van den Hout



- and J. de Roos, 73–85. Istanbul: Nederlands Historisch-Archaeologisch Instituut.
- . 2000. *Corpus of Hieroglyphic Luwian Inscriptions*. Vol. 1, *Inscriptions of the Iron Age*. Berlin: Walter de Gruyter.
- . 2002. “Anatolia: The End of the Hittite Empire and After.” In *Die nahöstlichen Kulturen und Griechenland an der Wende vom 2. zum 1. Jahrtausend v. Chr.: Kontinuität und Wandel von Strukturen und Mechanismen kultureller Interaktion*, edited by E.A. Braun-Holzinger and H. Matthäus, 143–51. Möhnesee, Germany: Bibliopolis.
- . 2009. “Cilicia, the Amuq and Aleppo: New Light in a Dark Age.” *NEA* 72(4):164–73.
- . 2011. “The Inscriptions of the Aleppo Temple.” *AnatSt* 61:35–54.
- Hein, A., V. Kilikoglou, and V. Kassianidou. 2007. “Chemical and Mineralogical Examination of Metallurgical Ceramics from a Late Bronze Age Copper Smelting Site in Cyprus.” *JAS* 34:141–54.
- Herbordt, S. 2006. “Hittite Glyptic: A Reassessment in the Light of Recent Discoveries.” In *Structuring and Dating in Hittite Archaeology*, edited by D.P. Mielke, U.-D. Schoop, and J. Seeher, 95–108. Byzas 4. Istanbul: Ege Yayınları.
- Herrmann, C. 2009. “Faience Amulets.” In *Excavations at Tel Beth-Shean, 1989–1996*. Vol. 3, *The 13th–11th Century BCE Strata in Areas N and S*, edited by N. Panitz-Cohen and A. Mazar, 714–18. Jerusalem: Israel Exploration Society and Institute of Archaeology, Hebrew University of Jerusalem.
- Hillson, S. 1992. *Mammal Bones and Teeth*. London: Institute of Archaeology, University College London.
- Horowitz, M. 2015. “The Evolution of Plain Ware Ceramics at the Regional Capital of Alalakh in the 2nd Millennium BC.” In *Plain Pottery Traditions of the Eastern Mediterranean and Near East: Production, Use and Social Significance*, edited by C. Glatz, 153–81. London: Routledge.
- Horowitz, M.T., and C. Çakırlar. 2017. “Novel Uses of Wild Faunal Resources at Transitional Middle–Late Bronze Age Tell Atchana.” In *Overturing Certainties in Near Eastern Archaeology: A Festschrift in Honor of K. Ashhan Yener*, edited by Ç. Maner, M.T. Horowitz, and A.S. Gilbert, 222–44. Leiden: Brill.
- Iacovou, M. 2008. “Cultural and Political Configurations in Iron Age Cyprus: The Sequel to a Prehistoric Episode.” *AJA* 112(4):625–57.
- Ikram, S. 2003. “A Preliminary Study of Zooarchaeological Changes Between the Bronze and Iron Ages at Kinet Höyük, Hatay.” In *Identifying Changes: The Transition from Bronze to Iron Ages in Anatolia and Its Neighbouring Regions*, edited by B. Fischer, H. Genz, E. Jean, and K. Köroğlu, 283–94. Istanbul: Türk Eskiçağ Bilimleri Enstitüsü.
- Iwasaki, T., K. Wakita, S. Ishida, and H. Wada. 2009. *Tell Mastuma: An Iron Age Settlement in Northwest Syria*. Tokyo: Ancient Orient Museum.
- Janeway, B. 2008. “The Nature and Extent of Aegean Contact at Tell Ta’ayinat and Vicinity in the Early Iron Age: Evidence of the Sea Peoples?” *Scripta Mediterranea* 27–28:123–46.
- . 2011. “Mycenaean Bowls at 12th/11th century B.C. Tell Tayinat (Amuq Valley).” In *On Cooking Pots, Drinking Cups, Loomweights and Ethnicity in Bronze Age Cyprus and Neighbouring Regions*, edited by V. Karageorghis and O. Kouka, 167–85. Nicosia: A.G. Leventis Foundation.
- . 2017. *Sea Peoples of the Northern Levant? Aegean-Style Pottery from Early Iron Age Tell Tayinat*. Studies in the History and Archaeology of the Levant 7. Winona Lake, Ind.: Eisenbrauns.
- Jean, E. 2003. “From Bronze to Iron Ages in Cilicia: The Pottery in Its Stratigraphic Context.” In *Identifying Changes: The Transition from Bronze to Iron Ages in Anatolia and Its Neighbouring Regions*, edited by B. Fischer, H. Genz, E. Jean, and K. Köroğlu, 79–91. Istanbul: Türk Eskiçağ Bilimleri Enstitüsü.
- Jung, R. 2006. “Die mykenische Keramik von Tell Kazel (Syrien).” *DM* 15:147–218.
- . 2007. “Tell Kazel and the Mycenaean Contacts with Amurru (Syria).” In *The Synchronisation of Civilisations in the Eastern Mediterranean in the Second Millennium B.C.* Vol. 3, edited by M. Bietak and E. Czerny, 551–70. Vienna: Österreichische Akademie der Wissenschaften.
- . 2010. “La céramique de typologie Mycénienne.” In *Tell Tweini: Onze campagnes de fouilles syro-belges (1999–2010)*, edited by M. al-Maqdissi, K. Van Lerberghe, J. Bretschneider, and M. Badawi, 115–21. Damascus: Ministère de la Culture, Direction Générale des Antiquités et des Musées.
- . 2012. “Can We Say, What’s Behind All Those Sherds? Ceramic Innovations in the Eastern Mediterranean at the End of the Second Millennium.” In *Materiality and Social Practice: Transformative Capacities of Intercultural Encounters*, edited by J. Maran and P.W. Stockhammer, 104–20. Oxford: Oxbow Books.
- Karageorghis, V. 1990. *The End of the Late Bronze Age in Cyprus*. Nicosia: Pierides Foundation.
- . 2011. “What Happened in Cyprus ca. 1200 BC: Hybridization, Creolization or Immigration? An Introduction.” In *On Cooking Pots, Drinking Cups, Loomweights and Ethnicity in Bronze Age Cyprus and Neighbouring Regions*, edited by V. Karageorghis and O. Kouka, 19–28. Nicosia: A.G. Leventis Foundation.
- Karageorghis, V., and E. Masson. 1975. “A propos de la découverte d’écaillés d’armure en bronze à Gastria-Alaas (Chypre).” *AA* 1975:209–22.
- Khalifeh, I.A. 1988. *Sarepta*. Vol. 2, *The Late Bronze and Iron Age Periods of Area II, X. The University Museum of the University of Pennsylvania Excavations at Sarafand, Lebanon*. Beirut: Département des publications de l’Université libanaise.
- Killebrew, A. 2005. *Biblical Peoples and Ethnicity: An Archaeological Study of Egyptians, Canaanites, Philistines and Early Israel, 1300–1100 BCE*. Atlanta, Ga.: Society of Biblical Literature.
- Killebrew, A., and G. Lehmann, eds. 2013. *The Philistines and Other “Sea Peoples” in Text and Archaeology*. Archaeology and Biblical Studies 15. Atlanta, Ga.: Society of Biblical Literature.
- Kling, B. 1991. “A Terminology for the Matte-Painted, Wheel-made Pottery of Late Cypriot IIC–IIIA.” In *Cypriot Ce-*

- ramics: *Reading the Prehistoric Record*, edited by J. Barlow, D.L. Bolger, and B. Kling, 181–84. University Museum Monograph 74. Philadelphia: University of Pennsylvania Museum of Archaeology and Anthropology.
- Knapp, A.B., and S.W. Manning. 2016. "Crisis in Context: The End of the Late Bronze Age in the Eastern Mediterranean." *AJA* 120(1):99–149.
- Koehl, R. 1985. *Sarepta*. Vol. 3, *The Imported Bronze and Iron Age Wares from Area II*, X. Beirut: Librairie Orientale.
- . 2017. "Were There Sea Peoples at Alalakh (Tell Atchana)?" In *Overturning Certainties in Near Eastern Archaeology: A Festschrift in Honor of K. Aslihan Yener*, edited by Ç. Maner, M.T. Horowitz, and A.S. Gilbert, 275–95. Leiden: Brill.
- Kohlmeyer, K. 2000. *Der Tempel des Wettergottes von Aleppo*. Münster: Rhema.
- . 2011. "Building Activities and Architectural Decoration in the 11th Century B.C.: The Temples of Taita, King of Padasitini/Palistin in Aleppo and 'Ain Dārā." In *Empires After the Empire: Anatolia, Syria and Assyria After Suppiluliuma II (ca. 1200–800/700 B.C.)*, edited by K. Strobel, 255–80. Florence: LoGisma editore.
- Korbel, G. 1985. *Die spätbronzezeitliche Keramik von Norşuntepe*. Institut für Bauen und Planen in Entwicklungsländern Mitteilungen 4. Hannover: Institut für Bauen und Planen in Entwicklungsländern.
- . 1987. *Materialheft Spätbronzezeitliche Keramik: Tarsus (Grabung Hetty Goldman)*. Hannover-Isernhagen: Selbstverlag des Instituts für Bauen und Planen in Entwicklungsländern.
- Kozal, E. 2013. "Exploring Sirkeli Höyük in the Late Bronze Age and Its Interregional Connections." In *Across the Border: Late Bronze–Iron Age Relations Between Syria and Anatolia*, edited by K.A. Yener, 213–25. Leuven: Peeters.
- Lagarce, J., and E. Lagarce. 1988. "The Intrusion of the Sea Peoples and Their Acculturation: A Parallel between Palestinian and Ras Ibn Hani Data." In *Studies in the History and Archaeology of Palestine: Proceedings of the 1st International Symposium on Palestine Antiquities*, edited by S. Saath, 137–69, 308–33. Aleppo: Jāmi'at Halab.
- Laroche, E. 1960. *Les hiéroglyphes Hittites, première partie: L'écriture*. Paris: Éditions du Centre National de la Recherche Scientifique.
- Linseele, V. 2010. "Étude faunique sur le site de Tell Tweini." In *Tell Tweini: Onze campagnes de fouilles syro-belges (1999–2010)*, edited by M. al-Maqdissi, K. Van Lerberghe, J. Bretschneider, and M. Badawi, 153–60. Damascus: Ministère de la Culture, Direction Générale des Antiquités et des Musées.
- Lumb, D. 2014. "Textile Traditions of Northwest Syria During the Early Iron Age." In *Textile Trade and Distribution in Antiquity / Textilhandel und -distribution in der Antike*, edited by K. Droß-Krüpe, 141–50. Wiesbaden: Harrasowitz Verlag.
- Manning, S., B. Lorentzen, T. Harrison, L. Welton, S. Batiuk, and C. Bronk Ramsey. Forthcoming. "Resolving the Absolute Chronology of the Early Iron Age in the Northern Levant: Tell Tayinat."
- Manuelli, F. 2013. "Pottery as an Indicator of Changing Interregional Relations in the Upper Euphrates Valley: The Case of the Late Bronze–Iron Age Assemblages from Arslantepe/Malatya." In *Across the Border: Late Bronze–Iron Age Relations between Syria and Anatolia*, edited by K.A. Yener, 373–91. Leuven: Peeters.
- Maran, J. 2004. "The Spreading of Objects and Ideas in the Late Bronze Age Eastern Mediterranean: Two Case Examples from the Argolid of the 13th and 12th Centuries B.C." *BASOR* 336:11–30.
- Martin, M. 2013. "The Late Bronze IIB Pottery from Levels K-8 and K-7." In *Megiddo V, The 2004–2008 Seasons*. Vol. 2, edited by I. Finkelstein, D. Ussishkin, and E.H. Cline, 343–457. Winona Lake, Ind.: Eisenbrauns.
- Mazar, A. 2015. "Iron Age I: Northern Coastal Plain, Galilee, Samaria, Jezreel Valley, and Negev." In *The Ancient Pottery of Israel and Its Neighbors from the Iron Age Through the Hellenistic Period*, edited by S. Gitin, 5–70. Jerusalem: Israel Exploration Society.
- Mazzoni, S. 2000. "Syria and the Periodization of the Iron Age: A Cross-Cultural Perspective." In *Essays on Syria in the Iron Age*, edited by G. Bunnens, 31–59. Ancient Near Eastern Studies Suppl. 7. Leuven: Peeters.
- Middleton, G.D. 2015. "Telling Stories: The Mycenaean Origins of the Philistines." *OJA* 34(1):45–65.
- Mommsen, H., and P. Pavúk. 2007. "Provenance of the Grey and Tan Wares from Troia, Cyprus and the Levant." *Studia Troica* 17:25–41.
- Monchambert, J.-Y. 1983. "La céramique de fabrication locale à Ougarit à la fin du Bronze récent: Quelques exemples." *Syria* 60(1/2):25–45.
- . 2008. "La céramique du Bronze récent à Ougarit." In *Ougarit au Bronze moyen et au Bronze récent*, edited by Y. Calvet and M. Yon, 149–57. Paris: De Boccard.
- Mountjoy, P.A. 2005a. "The Mycenaean Pottery from the 1934–1939 Excavations at Tarsus." In *Field Seasons 2001–2003 of the Tarsus-Gözlükule Interdisciplinary Research Project*, edited by A. Özyar, 83–134. Istanbul: Ege Yayınları.
- . 2005b. "The End of the Bronze Age at Enkomi, Cyprus: The Problem of Level IIIB." *BSA* 100:125–214.
- . 2010. "A Note on the Mixed Origins of Some Philistine Pottery." *BASOR* 359:1–12.
- Muhlenbruch, T.M., J.H. Sterba, and D. Sürenhagen. 2009. "Neutronaktivierungsanalysen an Keramik aus Tell Djin-deris/Gindaros." *Ägypten und Levante* 19:219–27.
- Müller, U. 1999. "Die eisenzeitliche Stratigraphie von Lidar Höyük." *AnatSt* 49:123–31.
- . 2003. "A Change to Continuity: Bronze Age Traditions in the Early Iron Age." In *Identifying Changes: The Transition from Bronze to Iron Ages in Anatolia and Its Neighbouring Regions*, edited by B. Fischer, H. Genz, E. Jean, and K. Köroğlu, 137–47. Istanbul: Türk Eskiçağ Bilimleri Enstitüsü.
- . 2005. "Norşun Tepe and Lidar Höyük: Two Examples for Cultural Change During the Early Iron Age." In *Anatolian Iron Ages 5*, edited by A. Çilingiroğlu and G. Darbyshire, 107–14. London: British Institute at Ankara.
- Müller-Karpe, A. 1988. *Hethitische Töpferei der Oberstadt von*

- Hattuša: Ein Beitrag zur Kenntnis spät-grossreichszeitlicher Keramik und Töpferbetriebe unter Zugrundelegung der Grabungsergebnisse von 1978–82 in Boğazköy. Marburger Studien zur Vor- und Frühgeschichte 10. Marburg: Hitzeroth.
- Murray, S.C. 2017. *The Collapse of the Mycenaean Economy: Imports, Trade and Institutions 1300–700 BCE*. Cambridge: Cambridge University Press.
- Oren, E., ed. 2000. *The Sea Peoples and Their World: A Re-assessment*. Philadelphia: University of Pennsylvania Museum.
- Osborne, J.F. 2011. "Spatial Analysis and Political Authority in the Iron Age Kingdom of Patina, Turkey." Ph.D. diss., Harvard University.
- . 2017. "Exploring the Lower Settlements of Iron Age Capitals in Anatolia and Syria." *Antiquity* 91:90–107.
- Osborne, J.F., and S. Karacic. 2017. "Urbanism Beyond the Acropolis: The Tayinat Lower Town Project Surface Survey, 2014–2015." *Anatolica* 43:37–70.
- Osborne, J.F., T.P. Harrison, S. Batiuk, L. Welton, J.P. Dessel, E. Denel, and Ö. Demirci. Forthcoming. "Urban Built Environments of the Early First Millennium BCE: Results of the Tayinat Archaeological Project, 2004–2012."
- Panitz-Cohen, N. 2009. "The Local Canaanite Pottery." In *Excavations at Tel Beth-Shean, 1989–1996*. Vol. 3, *The 13th–11th Century BCE Strata in Areas N and S*, edited by N. Panitz-Cohen and A. Mazar, 195–433. Jerusalem: Israel Exploration Society and Institute of Archaeology, Hebrew University of Jerusalem.
- Parzinger, H., and R. Sanz. 1992. *Die Oberstadt von Hattuša: Hethitische Keramik aus dem zentralen Tempelviertel*. Boğazköy-Hattuša 15. Berlin: Gebr. Mann.
- Pavúk, P. 2010. "Minyan or Not: The Second Millennium Grey Ware in Western Anatolia and Its Relation to Mainland Greece." In *Mesohelladika: La Grèce continentale au Bronze moyen*, edited by A. Philippa-Touchais, G. Touchais, S. Voutsaki, and J. Wright, 931–43. Athens: École française d'Athènes.
- . 2014. *Troia VI Früh und Mitte: Keramik, Stratigraphie, Chronologie*. Studia Troica Monographien 3. Bonn: Habelt.
- Payne, S. 1985. "Morphological Distinctions Between the Mandibular Teeth of Young Sheep, *Ovis*, and Goats, *Capra*." *JAS* 12:139–47.
- Pizzimenti, S., and F. Zaina. 2016. "The Iron Age at Karke-mish Between Tradition and Innovation: The Case Study of the Pottery Assemblage from Area C." In *Proceedings of the 9th International Congress on the Archaeology of the Ancient Near East, 9–13 June 2014, Basel*. Vol. 3, edited by R.A. Stucky, O. Kaelin, and H.-P. Mathys, 361–76. Wiesbaden: Harrassowitz Verlag.
- Postgate, N. 2007. "The Ceramics of Centralisation and Dissolution: A Case Study from Rough Cilicia." *AnatSt* 47:141–50.
- . 2008. "The Chronology of the Iron Age Seen from Kilise Tepe." *Ancient Near Eastern Studies* 45:166–87.
- Pucci, M. 2010. "The Chatal Höyük Publication Project: A Work in Progress." In *Proceedings of the 6th International Congress of the Archaeology of the Ancient Near East*. Vol. 2, edited by P. Matthiae, F. Pinnock, L. Nigro, and N. Marchetti, 567–80. Wiesbaden: Harrassowitz Verlag.
- . 2013. "Chatal Höyük in the Amuq: Material Culture and Architecture During the Passage from the Late Bronze Age to the Early Iron Age." In *Across the Border: Late Bronze–Iron Age Relations Between Syria and Anatolia*, edited by K.A. Yener, 89–112. Leuven: Peeters.
- . Forthcoming. *Excavations in the Plain of Antioch*. Vol. 3, *Stratigraphy, Pottery and Small Finds from the Oriental Institute Excavations at Chatal Höyük in the Amuq*. Chicago: Oriental Institute Publications.
- Rahmstorf, L. 2003. "Clay Spools from Tiryns and Other Contemporary Sites: An Indication of Foreign Influence in LH IIIC?" In *The Periphery of the Mycenaean World: 2nd International Interdisciplinary Colloquium, 26–30 September, Lamia 1999*, edited by N. Kyparissi-Apostolika and M. Papakonstantinou, 397–415. Athens: Ministry of Culture.
- . 2005. "Ethnicity and Changes in Weaving Technology in Cyprus and the Eastern Mediterranean in the 12th Century BC." In *Cyprus: Religion and Society from the Late Bronze Age to the End of the Archaic Period*, edited by V. Karageorghis, H. Matthäus, and S. Rogge, 143–69. Möhnesee, Germany: Bibliopolis.
- . 2008. *Kleinfunde aus Tiryns: Terrakotta, Stein, Bein und Glas/Fayence vornehmlich aus der Spätbronzezeit*. Wiesbaden: Reichert Verlag.
- . 2011. "Handmade Pots and Crumbling Loomweights: 'Barbarian' Elements in the Eastern Mediterranean in the Last Quarter of the 2nd Millennium BC." In *On Cooking Pots, Drinking Cups, Loomweights and Ethnicity in Bronze Age Cyprus and Neighbouring Regions*, edited by V. Karageorghis and O. Kouka, 315–30. Nicosia: A.G. Leventis Foundation.
- Riehl, S. 2009. "Archaeobotanical Evidence for the Interrelationship of Agricultural Decision-Making and Climate Change in the Ancient Near East." *Quaternary International* 197:93–114.
- . 2010a. "Flourishing Agriculture in Times of Political Instability: The Archaeobotanical and Isotopic Evidence from Tell Atchana." In *Tell Atchana, Ancient Alalakh*. Vol. 1, *The 2003–2004 Seasons*, edited by K.A. Yener, 123–36. Istanbul: Koç Üniversitesi Yayınları.
- . 2010b. "Plant Production in a Changing Environment: The Archaeobotanical Remains from Tell Mozan." In *Development of the Environment, Subsistence and Settlement of the City of Urkeš and Its Region*, edited by K. Deckers, M. Doll, P. Pfälzner, and S. Riehl, 13–158. Studien zur Urbanisierung Nordmesopotamiens ser. A, 3. Wiesbaden: Harrassowitz.
- Rieken, E. 2010. "Das Zeichen <sa> im Hieroglyphen-Luwischen." In *Acts of the VIIth International Congress of Hittitology, Çorum, August 25–31, 2008*, edited by A. Suel, 651–60. Ankara: T.C. Çorum Valiliği.
- Rieken, E., and I. Yakubovich. 2010. "The New Values of Luwian Signs L 319 and L 172." In *Ipamati kistamati paritumatimis: Luwian and Hittite Studies Presented to David Hawkins on the Occasion of His 70th Birthday*, edited by I. Singer, 199–219. Tel Aviv: Tel Aviv University.

- Riis, P.J. 1948. *Hama*. Vol. 2, pt. 3, *Les cimetières à crémation: Fouilles et recherches de la Fondation Carlsberg, 1931–1938*. Copenhagen: Nordisk Forlag.
- Roames, J. 2011. "The Early Iron Age Metal Workshop at Tell Tayinat, Turkey." In *Material Issues in Art and Archaeology IX*, edited by P. Vandiver, W. Li, J.L. Ruvalcaba Sil, C. Reedy, and L. Frame, 149–55. MRS Proceedings 1319. Cambridge: Cambridge University Press.
- Schaeffer, C.F.A. 1962. "Fouilles et découvertes des XVIIIe et XIXe campagnes, 1954–1955." In *Ugaritica IV*, edited by C.F.A. Schaeffer, 1–150. Paris: Librairie orientaliste Paul Geuthner.
- Schmid, E. 1972. *Atlas of Animal Bones*. Amsterdam: Elsevier.
- Schneider, T. 2011. "The Philistine Language: New Etymologies and the Name 'David.'" *UgaritF* 43:569–80.
- Schoop, U.-D. 2003. "Pottery Traditions of the Later Hittite Empire: Problems of Definition." In *Identifying Changes: The Transition from Bronze to Iron Ages in Anatolia and Its Neighbouring Regions*, edited by B. Fischer, H. Genz, E. Jean, and K. Köroğlu, 167–78. Istanbul: Ege Yayınları.
- Sevin, V., and K. Köroğlu. 2004. "Late Bronze Age at Yumuktepe: New Evidence from Step-Trench South." In *Mersin-Yumuktepe: A Reappraisal*, edited by I. Caneva and V. Sevin, 73–83. Lecce, Italy: Dipartimento di Beni Culturali Università degli Studi.
- Sherratt, S. 1998. "Sea Peoples' and the Economic Structure of the Late Second Millennium in the Eastern Mediterranean." In *Mediterranean Peoples in Transition: Thirteenth to Early Tenth Centuries BCE*, edited by S. Gitin, A. Mazar, and E. Stern, 292–313. Jerusalem: Israel Exploration Society.
- . 2003. "The Mediterranean Economy: 'Globalization' at the End of the Second Millennium BCE." In *Symbiosis, Symbolism and the Power of the Past: Canaan, Ancient Israel and Their Neighbors from the Late Bronze Age Through Roman Palaestina*, edited by W.G. Dever and S. Gitin, 37–62. Winona Lake, Ind.: Eisenbrauns.
- . 2013. "The Ceramic Phenomenon of the 'Sea Peoples': An Overview." In *The Philistines and Other "Sea Peoples" in Text and Archaeology*, edited by A. Killebrew and G. Lehmann, 619–44. Archaeology and Biblical Studies 15. Atlanta, Ga.: Society of Biblical Literature.
- Silver, I.A. 1963. "The Aging of Domestic Animals." In *Science in Archaeology*, edited by D. Brothwell and E.S. Higgs, 250–68. New York: Praeger.
- Singer, I. 2012. "The Philistines in the North and the Kingdom of Taita." In *The Ancient Near East in the 12th–10th Centuries BCE: Culture and History*, edited by G. Galil, A. Gilboa, A.M. Maier, and D. Kahn, 451–72. AOAT 392. Münster: Ugarit-Verlag.
- Soldi, S. 2013. "Red Slip Ware from the Acropolis of Tell Afis: The Evidence of Area G." In *Syrian Archaeology in Perspective: Celebrating 20 Years of Excavations at Tell Afis*, edited by S. Mazzoni and S. Soldi, 199–222. Pisa: Edizioni ETS.
- Stager, L. 1995. "The Impact of the Sea Peoples." In *The Archaeology of Society in the Holy Land*, edited by T. Levy, 332–48. Leicester: University of Leicester Press.
- Steel, L. 2013. "Cyprus During the Late Bronze Age." In *The Oxford Handbook of the Archaeology of the Levant, 8000–332 BCE*, edited by M. Steiner and A. Killebrew, 577–91. Oxford: Oxford University Press.
- Stern, E. 2013. *The Material Culture of the Northern Sea Peoples in Israel*. Winona Lake, Ind.: Eisenbrauns.
- Stirn, M.A. 2013. "Are the Grains All-Alakh? An Archaeobotanical Exploration of Agricultural Practices and Transitions at Late Bronze Age Alalakh (Tell Atchana)." M.Sc. thesis, University of Sheffield.
- Stone, E., and P.E. Zimansky. 1999. *The Iron Age Settlement at 'Ain Dara, Syria: Survey and Soundings*. BAR-IS786. Oxford: Archaeopress.
- Strobel, K. 2011. "The Crucial 12th Century B.C.: The 'Fall of Empires' Revisited." In *Empires After the Empire: Anatolia, Syria and Assyria After Suppiluliuma II (ca. 1200–800/700 B.C.)*, edited by K. Strobel, 167–254. Florence: LoGisma editore.
- Stronach, D. 1959. "The Development of the Fibula in the Near East." *Iraq* 21(2):180–206.
- Summers, G.D. 1993. *Tille Höyük*. Vol. 4, *The Late Bronze Age and the Iron Age Transition*. British Institute of Archaeology at Ankara Monograph 15. Ankara: British Institute of Archaeology at Ankara.
- . 2013. "Some Implications of Revised C14 and Dendrochronological Dating for the 'Late Bronze Levels' at Tille Höyük on the Euphrates." In *Across the Border: Late Bronze–Iron Age Relations Between Syria and Anatolia*, edited by K.A. Yener, 311–28. Leuven: Peeters.
- Sürenhagen, D. 1986. "Ein Königssiegel aus Kargamis." *MDOG* 118:183–90.
- . 1999. "Tell Gindaris and the Western Afrin Valley." *AAS* 43:159–67.
- Swift, G.F. 1958. "The Pottery of the 'Amuq, Phases K to O, and Its Historical Relationships." Ph.D. diss., University of Chicago.
- Thalmann, J.-P. 2006. *Tell Arqa*. Vol. 1, *Les niveaux de l'âge du Bronze*. Beirut: Bibliothèque Archéologique et Historique.
- Tufnell, O. 1953. *Lachish*. Vol. 3, *The Iron Age*. Oxford: Oxford University Press.
- . 1958. *Lachish*. Vol. 4, *The Bronze Age*. Oxford: Oxford University Press.
- Ünlü, E. 2005. "Locally Produced and Painted Late Bronze to Iron Age Transitional Period Pottery of Tarsus-Gözlükule." In *Field Seasons 2001–2003 of the Tarsus-Gözlükule Interdisciplinary Research Project*, edited by A. Özyar, 145–60. Istanbul: Ege Yayınları.
- . 2015. "Late Bronze–Early Iron Age Painted Pottery from the Northeastern Mediterranean Settlements." In *NOSTOI: Indigenous Culture, Migration, Integration in the Aegean Islands and Western Anatolia During the Late Bronze Age and Early Iron Age*, edited by N.C. Stampolidis, Ç. Maner, and K. Kopanias, 517–30. Istanbul: Koç University Press.
- . 2016. "Tarsus-Gözlükule Höyüğü Geç Tunç IIb Katmanında Rastlanan Seramik Devamlılıkları." *CEDRUS: Journal of Mediterranean Civilisations Studies* 4:1–9.
- . 2017. "Tell Tayinat Yerleşiminde Geç Tunç: Erken Demir Çağı Geçiş Dönemi Seramikleri Üzerinden Amik

- Ovası'nda Görülen Yerel Devamlılıklar ve Doğu Akdeniz Bağlantıları." *OLBA: The Journal of Research Center for Cilian Archaeology* 25:91–111.
- Vansteenhuyse, K. 2010. "La céramique du Chantier A." In *Tell Tweini: Onze campagnes de fouilles syro-belges (1999–2010)*, edited by M. al-Maqdissi, K. Van Lerberghe, J. Bretschneider, and M. Badawi, 95–114. Damascus: Ministère de la Culture, Direction Générale des Antiquités et des Musées.
- Vansteenhuyse, K., and J. Bretschneider. 2011. "Handmade Cooking Pots from the Early Iron Age in Tell Tweini (Syria)." In *On Cooking Pots, Drinking Cups, Loomweights and Ethnicity in Bronze Age Cyprus and Neighbouring Regions*, edited by V. Karageorghis and O. Kouka, 187–94. Nicosia: A.G. Leventis Foundation.
- Veldhuijzen, H.A. 2009. "Hip to Be Square: How Tuyères Shaped the Hammeh Iron Production." In *Modesty and Patience: Archaeological Studies and Memories in Honour of Nabil Qadi 'Abu Salim'*, edited by H.G. Gebel, Z. Kafafi, and O. Al-Ghul, 114–25. Berlin: Yarmouk University.
- Venturi, F. 2000. "Tell Afis et la 'Dark Age' (les niveaux de la fin du Bronze récent II et de l'âge du Fer I)." In *First International Congress on the Archaeology of the Ancient Near East, May 18th–23rd 1998*, edited by P. Matthiae, A. Enea, L. Peyronel, and F. Pinnock, 1715–30. Rome: Università degli studi di Roma "La Sapienza."
- . 2007. *La Siria nell'età delle trasformazioni (XIII–X sec. a.C.): Nuovi contributi dallo scavo di Tell Afis*. Bologna: CLUEB.
- . 2010. "Cultural Breakdown or Evolution? The Impact of Changes in 12th Century BC Tell Afis." In *Societies in Transition: Evolutionary Processes in the Northern Levant Between Late Bronze Age II and Early Iron Age*, edited by F. Venturi, 1–27. Bologna: CLUEB.
- . 2011. "The Northern Syrian Plateau Before and After the Fall of the Hittite Empire: New Evidence from Tell Afis." In *Empires After the Empire: Anatolia, Syria and Assyria After Suppiluliuma II (ca. 1200–800/700 B.C.)*, edited by K. Strobel, 139–66. Florence: LoGisma editore.
- . 2013. "The Transition from the Late Bronze Age to the Early Iron Age at Tell Afis, Syria (Phases VII–III)." In *Across the Border: Late Bronze–Iron Age Relations Between Syria and Anatolia*, edited by K.A. Yener, 227–59. Leuven: Peeters.
- Verstraete, J., and T.J. Wilkinson. 2000. "The Amuq Regional Archaeological Survey." *AJA* 104(2):179–92.
- Vila, E. 2008. "L'économie alimentaire carnée et le monde animal: Analyse préliminaire des restes osseux de mammifères (Ras Shamra)." In *Ougarit au Bronze moyen et au Bronze récent*, edited by Y. Calvet and M. Yon, 169–79. Paris: De Boccard.
- Vila, E., and A.-S. Dalix. 2004. "Alimentation et idéologie: La place du sanglier et du porc à l'Âge du Bronze sur la côte Levantine." *Anthropozoologica* 39(1):219–36.
- Vogler, U. 1997. "Faunenhistorische Untersuchungen am Sirkeli Höyük/Adana, Turkey (4.–1. Jahrtausend v. Chr.)." Ph.D. diss., Institut für Palaeoanatomie, Domestikationsforschung und Geschichte der Tiermedizin, Ludwig-Maximilians-University.
- von Dassow, E. 2008. *State and Society in the Late Bronze Age: Alalah Under the Mitanni Empire*. Studies on the Civilization and Culture of Nuzi and the Hurrians 17. Bethesda, Md.: CDL Press.
- von den Dreisch, A. 1976. *A Guide to the Measurement of Animal Bones from Archaeological Sites*. Peabody Museum Bulletin 1. Cambridge: Peabody Museum Press.
- Voskos, I., and A.B. Knapp. 2008. "Cyprus at the End of the Late Bronze Age: Crisis and Colonization or Continuity and Hybridization?" *AJA* 112(4):659–84.
- Weeden, M. 2013. "After the Hittites: The Kingdoms of Karkamish and Palistin in Northern Syria." *BICS* 56:1–20.
- . 2015. "The Land of Walastin at Tell Tayinat." *Nouvelles Assyriologiques Brèves et Utilitaires* 2015(2):65–6.
- Welton, L. 2014. "Revisiting the Amuq Sequence: A Preliminary Investigation of the EBIVB Ceramic Assemblage from Tell Tayinat." *Levant* 46(3):339–70.
- Welton, L., S. Batiuk, and T.P. Harrison. 2011. "Tell Tayinat in the Late Third Millennium: Recent Investigations of the Tayinat Archaeological Project, 2008–2010." *Anatolica* 37:147–85.
- Wilkins, B. 1998. "The Faunal Remains." In *Tell Afis (Siria): Scavi sull'acropoli 1988–1992*, edited by S.M. Cecchini and S. Mazzoni, 433–50. Pisa: Edizioni ETS.
- Woolley, L. 1955. *Alalakh: An Account of the Excavations at Tell Atchana in the Hatay, 1937–1949*. Reports of the Research Committee of the Society of Antiquaries of London 18. London: Society of Antiquaries.
- Yalçın, S. 2013. "A Re-evaluation of the Late Bronze to Early Iron Age Transitional Period: Stratigraphic Sequence and Plain Ware of Tarsus-Gözlükule." In *Across the Border: Late Bronze–Iron Age Relations Between Syria and Anatolia*, edited by K.A. Yener, 195–212. Leuven: Peeters.
- Yasur-Landau, A. 2010. *The Philistines and Aegean Migration in the Late Bronze Age*. Cambridge: Cambridge University Press.
- Yener, K.A. 2013. "New Excavations at Alalakh: The 14th–12th Centuries B.C." In *Across the Border: Late Bronze–Iron Age Relations Between Syria and Anatolia*, edited by K.A. Yener, 11–36. Leuven: Peeters.
- Younger, K.L., Jr. 2016. *A Political History of the Arameans: From Their Origins to the End of Their Polities*. Atlanta, Ga.: Society of Biblical Literature.

## Supplementary Content: Appendix

Appendix to accompany the *American Journal of Archaeology* publication:

### Shifting Networks and Community Identity at Tell Tayinat in the Iron I (ca. 12th to Mid 10th Century B.C.E.)

Lynn Welton, Timothy Harrison, Stephen Batiuk, Elif Ünlü, Brian Janeway, Doğa Karakaya, David Lipovitch, David Lumb, and James Roames

Link to this article: <https://doi.org/10.3764/aja.123.2.0291>

Published online 18 March 2019

*American Journal of Archaeology* Volume 123 Number 2

DOI: 10.3764/ajaonline1232.Welton.suppl

This online-only published content is freely available electronically immediately upon publication and can be distributed under the Creative Commons Attribution-NonCommercial License (CC BY-NC). This license allows anyone to reuse, remix, and build upon the content, as long as it is for legal noncommercial purposes; the new work must credit the author, the *AJA*, and the Archaeological Institute of America.



Table 1. Zooarchaeological data from all field phases at Tayinat. NISP = number of identified specimens; MNI = minimum number of individuals.

	FP6b-a				FP5				FP4				FP3 (RAW DATA)				FP3 (ADJUSTED DATA)			
	NISP	% of Sample	% of Identifiable Mammal Remains	MNI	NISP	% of Sample	% of Identifiable Mammal Remains	MNI	NISP	% of Sample	% of Identifiable Mammal Remains	MNI	NISP	% of Sample	% of Identifiable Mammal Remains	MNI	NISP	% of Sample	% of Identifiable Mammal Remains	MNI
<i>Bos taurus</i>	38	1.69%	4.13%	3	124	2.29%	3.66%	4	9	1.73%	3.32%	1	121	2.00%	2.73%	3	121	2.20%	3.10%	3
<i>Cervus elaphus</i>	2	0.09%	0.22%	1	3	0.06%	0.09%	2	--	--	--	--	5	0.08%	0.11%	1	5	0.09%	0.13%	1
Large Bovid	--	--	--	--	2	0.04%	0.06%		1	0.19%	0.37%		3	0.05%	0.07%		3	0.05%	0.08%	
<i>Equus</i> sp.	1	0.04%	0.11%	1	15	0.28%	0.44%	1	1	0.19%	0.37%	1	5	0.08%	0.11%	1	5	0.09%	0.13%	1
<i>Camelus</i> sp.	--	--	--	--	--	--	--	--	--	--	--	--	1	0.02%	0.02%	1	1	0.02%	0.03%	1
<i>Sus scrofa</i>	34	1.51%	3.70%	5	67	1.24%	1.98%	6	5	0.96%	1.85%	1	73	1.21%	1.65%	5	73	1.33%	1.87%	5
<i>Ursus arctos</i>	--	--	--	--	--	--	--	--	--	--	--	--	1	0.02%	0.02%	1	1	0.02%	0.03%	1
Large Mammal	115	5.10%	12.51%		519	9.60%	15.33%		42	8.08%	15.50%		594	9.83%	13.39%		594	10.79%	15.24%	
TOTAL LARGE MAMMAL	190	8.43%	20.67%		730	13.51%	21.57%		58	11.15%	21.40%		803	13.29%	18.11%		803	14.59%	20.61%	
<i>Dama dama</i>	--	--	--	--	1	0.02%	0.03%	1	--	--	--	--	--	--	--	--	--	--	--	--
<i>Gazella</i> sp.	1	0.04%	0.11%	1	2	0.04%	0.06%	1	--	--	--	--	5	0.08%	0.11%	1	5	0.09%	0.13%	1
<i>Capra hircus</i>	20	0.89%	2.18%	5	74	1.37%	2.19%	6	8	1.54%	2.95%	2	85	1.41%	1.92%	5	85	1.54%	2.18%	5
<i>Ovis aries</i>	8	0.35%	0.87%	4	76	1.41%	2.25%	6	5	0.96%	1.85%	1	62	1.03%	1.40%	4	62	1.13%	1.59%	4
<i>Ovis/Capra</i>	122	5.41%	13.28%	17	495	9.16%	14.62%	15	31	5.96%	11.44%	3	603	9.98%	13.60%	17	603	10.95%	15.47%	17
TOTAL OVIS/CAPRA	150	6.65%	16.32%		645	11.93%	19.05%		44	8.46%	16.24%		750	12.41%	16.91%		750	13.62%	19.25%	
Medium Mammal	516	22.89%	56.15%		1850	34.23%	54.65%		156	30.00%	57.56%		2237	37.02%	50.44%		2237	40.64%	57.40%	
TOTAL MEDIUM MAMMAL	667	29.59%	72.58%		2498	46.22%	73.80%		200	38.46%	73.80%		2992	49.51%	67.46%		2992	54.35%	76.78%	
<i>Lepus</i> sp.	--	--	--	--	19	0.35%	0.56%	2	1	0.19%	0.37%	1	3	0.05%	0.07%	1	3	0.05%	0.08%	1
<i>Castor</i> sp.	--	--	--	--	--	--	--	--	--	--	--	--	1	0.02%	0.02%	1	1	0.02%	0.03%	1
<i>Canis</i> sp.	11	0.49%	1.20%	2	17	0.31%	0.50%	2	--	--	--	--	16	0.26%	0.36%	2	16	0.29%	0.41%	2
<i>Felis</i> sp.	--	--	--	--	1	0.02%	0.03%	1	--	--	--	--	--	--	--	--	--	--	--	--
Small Mammal	26	1.15%	2.83%		112	2.07%	3.31%		11	2.12%	4.06%		82	1.36%	1.85%		82	1.49%	2.10%	
TOTAL SMALL MAMMAL	37	1.64%	4.03%		149	2.76%	4.40%		12	2.31%	4.43%		102	1.69%	2.30%		102	1.85%	2.62%	
TOTAL VERY SMALL MAMMAL	25	1.11%	2.72%		8	0.15%	0.24%		1	0.19%	0.37%		538	8.90%	12.13%		--	--	--	
TOTAL IDENTIFIABLE MAMMAL	919	40.77%			3385	62.63%			271	52.12%			4435	73.39%			3897	70.79%		
Unidentified	794	35.23%			1749	32.36%			236	45.38%			1416	23.43%			1416	25.72%		
Fish	518	22.98%			229	4.24%			11	2.12%			124	2.05%			124	2.25%		
Bird	15	0.67%			40	0.74%			2	0.38%			46	0.76%			46	0.84%		
Turtle/Tortoise	3	0.13%			1	0.02%			--	--			6	0.10%			6	0.11%		
Amphibian	5	0.22%			1	0.02%			--	--			16	0.26%			16	0.29%		
<b>TOTAL</b>	<b>2254</b>				<b>5405</b>				<b>520</b>				<b>6043</b>				<b>5505</b>			

Table 2. Ubiquity scores and proportions of crop taxa at Late Bronze Age Tell Atchana (ALA\_L5-4 = Levels 5-4, ALA\_L3-2 = Levels 3-2) and Iron I Tell Tayinat (TAY\_P6 = FP6, TAY\_P5 = FP5, TAY\_P4-3 = FP4-3). Ubiquity represents the percentage of the samples in which each species is present; proportions represent the percentage of all botanical remains represented by each species.

Sample amount	ABSOLUTE COUNTS						UBIQUITY SCORES						PROPORTIONS								
	ALA_L5-4	ALA_L3-2	TAY_P6	TAY_P5	TAY_P4-3	ALA_TOTAL	TAY-TOTAL	ALA_L5-4	ALA_L3-2	TAY_P6	TAY_P5	TAY_P4-3	ALA_TOTAL	TAY-TOTAL	ALA_L5-4	ALA_L3-2	TAY_P6	TAY_P5	TAY_P4-3	ALA_TOTAL	TAY-TOTAL
	54	59	39	22	6	113	67	31	14	39	22	6	45	67	54	59	39	22	6	113	67
<i>Hordeum vulgare</i>	438	34	126	78	31	<b>472</b>	<b>235</b>	74.19	21.43	82.05	40.91	83.33	<b>57.78</b>	<b>68.66</b>	11.87	7.87	11.39	23.01	14.03	<b>11.45</b>	<b>13.92</b>
<i>Triticum</i> spp. (fr. thresh/gl.)	307	30	129	69	52	<b>337</b>	<b>250</b>	41.94	42.86	69.23	68.18	83.33	<b>42.22</b>	<b>70.15</b>	8.32	6.94	11.66	20.35	23.53	<b>8.18</b>	<b>14.81</b>
<i>Triticum aestivum/durum</i>	1551	98	192	66	63	<b>1649</b>	<b>321</b>	93.55	42.86	56.41	54.55	83.33	<b>77.78</b>	<b>58.21</b>	42.03	22.69	17.36	19.47	28.51	<b>40.00</b>	<b>19.02</b>
<i>Triticum dicoccum</i>	30	16	56	45	15	<b>46</b>	<b>116</b>	25.81	21.43	33.33	36.36	66.67	<b>24.44</b>	<b>37.31</b>	0.81	3.70	5.06	13.27	6.79	<b>1.12</b>	<b>6.87</b>
<i>Triticum monococcum</i>				2			<b>2</b>	0.00	0.00	0.00	4.55	0.00	<b>0.00</b>	<b>1.49</b>	0.00	0.00	0.00	0.59	0.00	<b>0.00</b>	<b>0.12</b>
<i>Hordeum vulgare</i> (chaff)	101	1	113	8	2	<b>102</b>	<b>123</b>	38.71	7.14	53.85	13.64	33.33	<b>28.89</b>	<b>38.81</b>	2.74	0.23	10.22	2.36	0.90	<b>2.47</b>	<b>7.29</b>
<i>Triticum aestivum/durum</i> (chaff)	227	6	78	9	7	<b>233</b>	<b>94</b>	29.03	0.00	38.46	27.27	33.33	<b>15.56</b>	<b>34.33</b>	6.15	1.39	7.05	2.65	3.17	<b>5.65</b>	<b>5.57</b>
<i>Triticum dicoccum</i> (chaff)	44		66	10		<b>44</b>	<b>76</b>	22.58	0.00	48.72	27.27	0.00	<b>20.00</b>	<b>37.31</b>	1.19	0.00	5.97	2.95	0.00	<b>1.07</b>	<b>4.50</b>
<i>Vicia/Lathyrus</i>	8	7	63	5	11	<b>15</b>	<b>79</b>	0.00	0.00	66.67	13.64	33.33	<b>0.00</b>	<b>46.27</b>	0.22	1.62	5.70	1.47	4.98	<b>0.36</b>	<b>4.68</b>
<i>Vicia ervilia</i>	818	70	21	10	2	<b>888</b>	<b>33</b>	74.19	57.14	23.08	31.82	33.33	<b>68.89</b>	<b>26.87</b>	22.17	16.20	1.90	2.95	0.90	<b>21.54</b>	<b>1.95</b>
<i>Lathyrus sativus/cicera</i>	4		6	2	4	<b>4</b>	<b>12</b>	0.00	0.00	10.26	9.09	50.00	<b>0.00</b>	<b>13.43</b>	0.11	0.00	0.54	0.59	1.81	<b>0.10</b>	<b>0.71</b>
<i>Vicia faba</i>		4	1			<b>4</b>	<b>1</b>	0.00	0.00	2.56	0.00	0.00	<b>0.00</b>	<b>1.49</b>	0.00	0.93	0.09	0.00	0.00	<b>0.10</b>	<b>0.06</b>
<i>Lens culinaris</i>	94	33	44	5	5	<b>127</b>	<b>54</b>	51.61	21.43	41.03	22.73	33.33	<b>42.22</b>	<b>34.33</b>	2.55	7.64	3.98	1.47	2.26	<b>3.08</b>	<b>3.20</b>
<i>Pisum sativum</i>			1	8			<b>9</b>	0.00	0.00	2.56	9.09	0.00	<b>0.00</b>	<b>4.48</b>	0.00	0.00	0.09	2.36	0.00	<b>0.00</b>	<b>0.53</b>
<i>Linum</i> sp.	13	1	9	1		<b>14</b>	<b>10</b>	9.68	7.14	10.26	4.55	0.00	<b>8.89</b>	<b>7.46</b>	0.35	0.23	0.81	0.29	0.00	<b>0.34</b>	<b>0.59</b>
<i>Vitis vinifera</i>	26	61	91	15	6	<b>87</b>	<b>112</b>	32.26	28.57	61.54	31.82	50.00	<b>31.11</b>	<b>50.75</b>	0.70	14.12	8.23	4.42	2.71	<b>2.11</b>	<b>6.64</b>
<i>Olea europaea</i> L.	7	14	89	5	22	<b>21</b>	<b>116</b>	19.35	35.71	48.72	4.55	16.67	<b>24.44</b>	<b>31.34</b>	0.54	13.19	1.90	0.29	0.45	<b>1.87</b>	<b>1.36</b>
<i>Ficus carica</i> L.	20	57	21	1	1	<b>77</b>	<b>23</b>	9.68	7.14	30.77	18.18	50.00	<b>8.89</b>	<b>28.36</b>	0.19	3.24	8.05	1.47	9.95	<b>0.51</b>	<b>6.87</b>