



**NAVAL  
POSTGRADUATE  
SCHOOL**

**MONTEREY, CALIFORNIA**

**THESIS**

**ORGANIZING FOR IRREGULAR WARFARE:  
IMPLICATIONS FOR THE BRIGADE COMBAT TEAM**

by

Kenneth J. Burgess

December 2007

Thesis Co-advisors:

Nancy Roberts  
Robert McNab

**Approved for public release; distribution is unlimited**

THIS PAGE INTENTIONALLY LEFT BLANK

<b>REPORT DOCUMENTATION PAGE</b>			<i>Form Approved OMB No. 0704-0188</i>
Public reporting burden for this collection of information is estimated to average 1 hour per response, including the time for reviewing instruction, searching existing data sources, gathering and maintaining the data needed, and completing and reviewing the collection of information. Send comments regarding this burden estimate or any other aspect of this collection of information, including suggestions for reducing this burden, to Washington headquarters Services, Directorate for Information Operations and Reports, 1215 Jefferson Davis Highway, Suite 1204, Arlington, VA 22202-4302, and to the Office of Management and Budget, Paperwork Reduction Project (0704-0188) Washington DC 20503.			
<b>1. AGENCY USE ONLY (Leave blank)</b>	<b>2. REPORT DATE</b> December 2007	<b>3. REPORT TYPE AND DATES COVERED</b> Master's Thesis	
<b>4. TITLE AND SUBTITLE</b> Organizing for Irregular Warfare: Implications for the Brigade Combat Team		<b>5. FUNDING NUMBERS</b>	
<b>6. AUTHOR</b> Kenneth J. Burgess		<b>8. PERFORMING ORGANIZATION REPORT NUMBER</b>	
<b>7. PERFORMING ORGANIZATION NAME(S) AND ADDRESS(ES)</b> Naval Postgraduate School Monterey, CA 93943-5000		<b>10. SPONSORING/MONITORING AGENCY REPORT NUMBER</b>	
<b>9. SPONSORING /MONITORING AGENCY NAME(S) AND ADDRESS(ES)</b> N/A		<b>11. SUPPLEMENTARY NOTES</b> The views expressed in this thesis are those of the author and do not reflect the official policy or position of the Department of Defense or the U.S. Government.	
<b>12a. DISTRIBUTION / AVAILABILITY STATEMENT</b> Approved for public release; distribution unlimited.		<b>12b. DISTRIBUTION CODE</b>	
<b>13. ABSTRACT</b>  This study challenges the notion that incremental steps taken by current Army modularity initiatives are bold enough to allow ground forces to properly conduct operations in twenty-first century irregular environments. This thesis argues that infantry brigade combat teams should be better optimized for the challenges of irregular warfare through structural changes that decentralize resources, flatten the command structure, and increase the capacity and integration of intelligence personnel, mobility assets, and population-focused capabilities at the battalion and company level. First, this study describes changes to the United States' threat environment and the evolving national security policies that are attempting to address these changes. A review of the Army's "transformation" identifies an obvious gap between capabilities inherent to the current force design and those directed by more recent policy documents. The study then examines a wide array of policy and structural alternatives from a variety of military analysts. Organizational theory is used to establish theoretical concepts, supported with historical insights, Army doctrine, contemporary articles, presentations, and interviews to assess the ability of tactical units to conduct intelligence, security, and civil-military operations. Finally, this study outlines a proposal to modify the current modular-brigade design, as a consideration for defense planners.			
<b>14. SUBJECT TERMS</b> Army, irregular warfare, brigade combat team, transformation, force structure, counterinsurgency, stability operations, foreign internal defense, SSTR, organizational theory, infantry, intelligence, civil affairs, mobility, Stryker, Armor, MRAP, military police, construction engineers, civil engineers, combat engineers.			<b>15. NUMBER OF PAGES</b> 175
			<b>16. PRICE CODE</b>
<b>17. SECURITY CLASSIFICATION OF REPORT</b> Unclassified	<b>18. SECURITY CLASSIFICATION OF THIS PAGE</b> Unclassified	<b>19. SECURITY CLASSIFICATION OF ABSTRACT</b> Unclassified	<b>20. LIMITATION OF ABSTRACT</b> UU

THIS PAGE INTENTIONALLY LEFT BLANK

**Approved for public release; distribution is unlimited**

**ORGANIZING FOR IRREGULAR WARFARE:  
IMPLICATIONS FOR THE BRIGADE COMBAT TEAM**

Kenneth J. Burgess  
Major, United States Army  
B.B.A., James Madison University, 1997

Submitted in partial fulfillment of the  
requirements for the degree of

**MASTER OF SCIENCE IN DEFENSE ANALYSIS**

from the

**NAVAL POSTGRADUATE SCHOOL  
December 2007**

Author: Kenneth J. Burgess

Approved by: Dr. Nancy Roberts  
Thesis Co-Advisor

Dr. Robert McNab  
Thesis Co-Advisor

Dr. Gordon McCormick  
Chairman, Department of Defense Analysis

THIS PAGE INTENTIONALLY LEFT BLANK

## **ABSTRACT**

This study challenges the notion that incremental steps taken by current Army modularity initiatives are bold enough to allow ground forces to properly conduct operations in twenty-first century irregular environments. This thesis argues that infantry brigade combat teams should be better optimized for the challenges of irregular warfare through structural changes that decentralize resources, flatten the command structure, and increase the capacity and integration of intelligence personnel, mobility assets, and population-focused capabilities at the battalion and company level. First, this study describes changes to the United States' threat environment and the evolving national security policies that are attempting to address these changes. A review of the Army's "transformation" identifies an obvious gap between capabilities inherent to the current force design and those directed by more recent policy documents. The study then examines a wide array of policy and structural alternatives from a variety of military analysts. Organizational theory is used to establish theoretical concepts, supported with historical insights, Army doctrine, contemporary articles, presentations, and interviews to assess the ability of tactical units to conduct intelligence, security, and civil-military operations. Finally, this study outlines a proposal to modify the current modular-brigade design, as a consideration for defense planners.

THIS PAGE INTENTIONALLY LEFT BLANK



# TABLE OF CONTENTS

I.	INTRODUCTION.....	1
A.	PURPOSE.....	1
B.	THESIS.....	5
C.	OUTLINE.....	7
D.	SCOPE AND LIMITATIONS.....	8
E.	TERMINOLOGY.....	11
II.	AN EVOLVING NATIONAL SECURITY STRATEGY.....	15
A.	CHANGING THREAT ENVIRONMENT.....	15
1.	Visions of the Future.....	16
2.	Weighing Risk.....	21
B.	POLICY FORMULATION.....	24
1.	The Quadrennial Defense Review.....	24
2.	DoD Directive 3000.05.....	26
3.	Joint Operating Concepts.....	27
III.	THE ARMY’S RESPONSE—“TRANSFORMATION”.....	33
A.	THE REVOLUTION IN MILITARY AFFAIRS.....	33
B.	ARMY TRANSFORMATION.....	35
1.	A Three-Pronged Strategy.....	35
2.	The Irregular Gap.....	37
3.	A New Direction?.....	42
C.	BRIGADE MODULARITY.....	43
1.	Heavy Brigade Combat Teams.....	46
2.	Stryker Brigade Combat Teams.....	47
3.	Infantry Brigade Combat Teams.....	49
4.	Multi-Functional Support Brigades.....	50
5.	Functional Support Brigades.....	51
D.	BELOW THE BRIGADE.....	52
1.	Intelligence.....	53
a.	<i>Brigade Intelligence</i> .....	53
b.	<i>Reconnaissance Squadrons</i> .....	54
c.	<i>Battalion-level Intelligence</i> .....	56
2.	Security and Mobility.....	56
a.	<i>Light Infantry</i> .....	56
b.	<i>Stryker</i> .....	58
c.	<i>Military Police</i> .....	58
3.	Civil-Military Operations.....	59
a.	<i>Information Operations</i> .....	59
b.	<i>Civil Affairs</i> .....	60
c.	<i>Engineers</i> .....	61
E.	ORGANIZATIONAL ADAPTATION?.....	61

<b>IV.</b>	<b>ALTERNATIVE MODELS FOR GROUND FORCE STRUCTURE .....</b>	<b>63</b>
<b>A.</b>	<b>POST-2003 CRITICISM AND ALTERNATIVE DESIGNS .....</b>	<b>64</b>
<b>B.</b>	<b>A NEW BLUEPRINT? .....</b>	<b>65</b>
<b>C.</b>	<b>A STABILIZATION FORCE? .....</b>	<b>66</b>
<b>D.</b>	<b>MORE MANEUVER ENHANCEMENT BRIGADES? .....</b>	<b>69</b>
<b>E.</b>	<b>MAAGS, FLAGS, STEGS, AND CORDS .....</b>	<b>70</b>
<b>F.</b>	<b>IDEALIZED MEDIUM-WEIGHT FORCES? .....</b>	<b>72</b>
<b>G.</b>	<b>TRENDS .....</b>	<b>73</b>
<b>V.</b>	<b>ANALYSIS OF THE CURRENT DESIGN FOR IRREGULAR WARFARE....</b>	<b>75</b>
<b>A.</b>	<b>THE ENVIRONMENT AND THE ORGANIZATION .....</b>	<b>77</b>
<b>B.</b>	<b>SPECIALIZATION .....</b>	<b>80</b>
<b>C.</b>	<b>DECENTRALIZATION AND INTEGRATION.....</b>	<b>83</b>
<b>C.</b>	<b>INTELLIGENCE OPERATIONS .....</b>	<b>88</b>
<b>D.</b>	<b>SECURITY AND MOBILITY .....</b>	<b>97</b>
<b>1.</b>	<b>Vehicles .....</b>	<b>97</b>
<b>2.</b>	<b>Military Police .....</b>	<b>101</b>
<b>3.</b>	<b>Combat Engineers.....</b>	<b>103</b>
<b>4.</b>	<b>Advising Foreign Security Forces.....</b>	<b>103</b>
<b>E.</b>	<b>CIVIL-MILITARY OPERATIONS .....</b>	<b>106</b>
<b>1.</b>	<b>Information Operations.....</b>	<b>107</b>
<b>2.</b>	<b>Civil Affairs .....</b>	<b>110</b>
<b>3.</b>	<b>Construction Engineers .....</b>	<b>115</b>
<b>F.</b>	<b>INSTITUTIONALIZING CHANGE .....</b>	<b>115</b>
<b>VI.</b>	<b>RECOMMENDATIONS.....</b>	<b>117</b>
<b>A.</b>	<b>OPTIMIZE FOR IRREGULAR WAR, MAINTAIN THE FLEXIBILITY .....</b>	<b>117</b>
<b>B.</b>	<b>INTELLIGENCE OPERATIONS .....</b>	<b>121</b>
<b>C.</b>	<b>SECURITY AND MOBILITY .....</b>	<b>125</b>
<b>1.</b>	<b>Vehicles .....</b>	<b>126</b>
<b>2.</b>	<b>Military Police .....</b>	<b>127</b>
<b>3.</b>	<b>Combat Engineers.....</b>	<b>129</b>
<b>4.</b>	<b>Advising Foreign Security Forces.....</b>	<b>131</b>
<b>D.</b>	<b>CIVIL-MILITARY OPERATIONS .....</b>	<b>133</b>
<b>1.</b>	<b>Information Operations.....</b>	<b>133</b>
<b>2.</b>	<b>Civil Affairs .....</b>	<b>135</b>
<b>3.</b>	<b>Construction Engineers .....</b>	<b>135</b>
<b>E.</b>	<b>FURTHER PROFESSIONALIZE THE FORCE .....</b>	<b>136</b>
<b>VII.</b>	<b>CONCLUSION .....</b>	<b>141</b>
	<b>LIST OF REFERENCES.....</b>	<b>147</b>
	<b>INITIAL DISTRIBUTION LIST .....</b>	<b>161</b>

## LIST OF FIGURES

Figure 1.	The Changing Threat Environment .....	21
Figure 2.	Conceptual Linkages.....	28
Figure 3.	Operational Lines of SSTR.....	29
Figure 4.	Army Transformation .....	36
Figure 5.	Active Component Brigade Allocation.....	46
Figure 6.	Heavy Brigade Combat Team (HBCT) .....	47
Figure 7.	Stryker Brigade Combat Team (SBCT).....	48
Figure 8.	Infantry Brigade Combat Team (IBCT) .....	50
Figure 9.	Multi-Functional Support Brigades Allocation .....	51
Figure 10.	Functional Support Brigade Allocation .....	52
Figure 11.	SBCT Military Intelligence Company .....	53
Figure 12.	Infantry BCT Reconnaissance Squadron .....	55
Figure 13.	Stryker BCT Reconnaissance Squadron .....	55
Figure 14.	Battalion Intelligence Section .....	56
Figure 15.	Infantry Rifle Company .....	57
Figure 16.	Brigade Staff .....	59
Figure 17.	Proposed Expansion of CA Capacity to Support a BCT .....	60
Figure 18.	Stability Operations Joint Task Force.....	68
Figure 19.	Mintzberg Structures.....	79
Figure 20.	Infantry Company Optimized for Irregular Environments .....	120
Figure 21.	Infantry Battalion Optimized for Irregular Environments .....	121
Figure 22.	Company Intelligence Collection and Analysis Team (CAT).....	123
Figure 23.	Battalion Intelligence Section.....	124
Figure 24.	Battalion Military Police Platoon.....	129
Figure 25.	Battalion Mobility Platoon.....	130
Figure 26.	Combat Capabilities for the Security and Development Brigades .....	133
Figure 27.	Battalion Information Operations Sections and Company IO Teams .....	134

THIS PAGE INTENTIONALLY LEFT BLANK

## **ACKNOWLEDGMENTS**

The author is extremely grateful for the encouragement and guidance provided by Dr. Nancy Roberts and Dr. Robert McNab. Their assistance was invaluable to this study. Additionally, the author thanks his wife, peers, and mentors who reviewed this thesis and provided candid and insightful feedback. Lastly, the author thanks the Soldiers and officers with whom he has served. It is with them in mind that he offers suggestions to improve his beloved institution.

THIS PAGE INTENTIONALLY LEFT BLANK

## I. INTRODUCTION

The Army ended up trying to fight the kind of conventional war that it was trained, organized, and prepared to fight instead of the counterinsurgency war it was sent to fight.<sup>1</sup>

### A. PURPOSE

During the final years of the Soviet Union, a theoretical discussion commonly known as the revolution in military affairs (RMA) began. Despite consistent U.S. involvement in irregular conflict, many of the influential authors of the 1990s imagined ways in which the U.S. could use information technologies and emerging weapon systems to dominate future battlefields. Assessments of the capabilities required for stabilization and counterinsurgency operations were largely ignored. After U.S. invasions, the rapid collapse of the Taliban regime in 2001 and the Baath Party in 2003 seemed to further solidify assumptions regarding “rapid decisive operations” and the power of information technology. However, defense planners’ enthusiasm quickly waned as the difficulties of post-conflict stabilization operations became apparent.

Meanwhile, the United States Army launched a restructuring plan in 1999 described as “the most comprehensive transformation of its force since World War II.”<sup>2</sup> According to the 2004 *Army Transformation Roadmap*, the short-term “decisive operation” within the Army Campaign Plan “is the creation of modular, combined arms maneuver brigade combat teams, or BCTs.”<sup>3</sup> The Army has dismantled divisional support units and created battalion and company-level combat support and combat service support units assigned directly to the brigade, while increasing the command and control capabilities of the brigade task force. In doing so, the brigade is advertised as

---

<sup>1</sup> Andrew Krepinevich, Jr., *The Army and Vietnam* (Baltimore: John Hopkins University Press, 1986), 271.

<sup>2</sup> The Office of the Deputy Chief of Staff, U.S. Army Operations, Army Transformation Office, *2004 Army Transformation Roadmap* (Washington D.C.: Department of Defense, July 2004), x, [http://www.oft.osd.mil/library/library\\_files/document\\_386\\_ATR\\_2004\\_Final.pdf](http://www.oft.osd.mil/library/library_files/document_386_ATR_2004_Final.pdf).

<sup>3</sup> The Army Transformation Office, *Transformation Roadmap*, 3-2.

becoming a more “expeditionary force,” able to deploy without additional resources. Divisions and brigades are intended to be tailored to their specific environment with augments from support brigades. Supporters of transformation applaud the flexible and strategic mobility the new concept provides. Some critics note the loss of traditional combat power in the new design compared with its predecessor due to a reduction in the number of maneuver battalions and firepower-based platforms. Others see the brigade modularity plan as a necessary and evolutionary step; but advocate far more reaching organizational changes if the Army is to be properly prepared for twenty-first century threats. These diverse philosophical camps are largely derived from varied opinions of technology’s potential and different assumptions regarding the future threat environment.

In the wake of the Cold War and the rising tide of destabilizing influences in societies worldwide, U.S. Army ground forces can expect to continue performing a myriad of tasks. These include conventional maneuver combat operations, providing military support to security, stabilization, transition, and reconstruction operations (SSTRO), assisting foreign nations counterinsurgency (COIN) efforts, and rapid response humanitarian operations. The threat of regional aggressor states, states that sponsor international terrorism, inter-state rivalries, and intra-state violence impact the United States’ concern for its own, and other states’ national security, economic stability, and human rights.

Unwilling to combat U.S. military forces or its allies directly, future adversaries will continue to embrace asymmetric means. They will focus their operations in cities where close terrain provides cover and the populace provides them information and concealment.<sup>4</sup> Guerrilla tactics and information campaigns will be used to counter-balance U.S. technological and resource advantages. U.S. ground forces must remain postured to complete national security initiatives through flexible and oftentimes simultaneous efforts to provide security, promote economic vitality, and support good

---

<sup>4</sup> Regarding the challenges and increased potential for urban operations, see U.S. Joint Forces Command, *Joint Urban Operations Joint Integrating Concept, Version 1.0* (Washington D.C.: Department of Defense, July 23, 2007), [http://www.dtic.mil/futurejointwarfare/concepts/juo\\_jic\\_v1.pdf](http://www.dtic.mil/futurejointwarfare/concepts/juo_jic_v1.pdf). See also, Williamson Murray, *War and Urban Terrain in the Twenty-First Century* (Alexandria: Institute for Defense Analyses, 2001).



governance at all levels. Known historically and generally as small-wars, military operations other than war, low-intensity conflict, and more recently as irregular warfare (IW); these operations may follow military invasions, be used to prevent weak states from collapsing, or to oppose insurgencies and terrorists in partner states.

Since the end of the Cold War, the U.S. military has been conducting foreign interventions approximately once every two years with the duration of each mission rising, and the scale of objectives increasingly expanding.<sup>5</sup> The current U.S. war in Iraq is the most ambitious of five preceding endeavors in the course of a decade to include military interventions in Somalia, Haiti, Bosnia, Kosovo, and Afghanistan. These missions have varied in their environments, purpose, duration, scale, and results; but all share common principles found in current stability operations and counterinsurgency literature. U.S. difficulties in Vietnam<sup>6</sup> and its ill-fated attempt at peace enforcement in Lebanon demonstrated the beginning of a continued poor record when enemies have adopted tactics poorly suited for the “American way” of war.<sup>7</sup> Despite what appears to be an “unavoidable burden” to the United States in an ever increasingly connected world,

---

<sup>5</sup> Irregular conflicts such as counterinsurgency and stability operations are typically protracted in nature. Historically, military efforts have required at least a decade to achieve positive political outcomes from the conflict. See, James Dobbins, Seth G. Jones, Keith Crane, and Beth Cole DeGrasse, *The Beginner's Guide to Nation-Building* (Santa Monica: RAND, 2007). Also, Thomas X. Hammes, “Insurgency: Modern Warfare Evolves into a Fourth Generation,” *Strategic Forum* no. 214 (2005), <http://www.ndu.edu/inss/Strforum/SF214/SF214.pdf>.

<sup>6</sup> Numerous sources describe early difficulties and then significant positive changes to U.S. ground strategies in the latter half of the U.S. ground involvement. Large-scale conventional search-and-destroy missions eventually lost emphasis as programs such as the Civil Operations and Revolutionary Development Support (CORDS) program, Vietnamese Civilian Irregular Defense Groups, and the Marine Corps' Combined Action Platoons demonstrated tangible, albeit late results. For a more detailed analysis see, Larry Cable, *Conflict of Myth* (New York: New York University Press, 1986); Krepinevich, *The Army and Vietnam*; Robert W. Komer, *Bureaucracy Does Its Thing: Institutional Constraints on U.S.-GVN Performance in Vietnam* (Santa Monica: RAND, 1972); and Bing West, *The Village* (New York: Pocket Books, 2003). Despite these studies, U.S. ground-force tactics are only one factor in understanding the eventual collapse of South Vietnam in 1975 after a Congressionally-demanded end to U.S. support of the ARVN.

<sup>7</sup> This term was popularized by Russell F. Weigley, *The American Way of War* (New York: Macmillan, 1973). It refers to a national predisposition for technology-centric, large-scale, conventional combat operations and an aversion to irregular warfare. See also, Max Boot, *The Savage Wars of Peace* (New York: Basic Books, 2002); Robert Cassidy, *Counterinsurgency and the Global War on Terror* (Westport: Praeger Security International, 2006); Jeffrey Record, “The American Way of War, Cultural Barriers to Successful Counterinsurgency,” Cato Institute paper, no. 577, September 1, 2006, <http://www.cato.org/pubs/pas/pa577.pdf>; and Mackubin Thomas Owens, “Counterinsurgency Comeback,” *Wall Street Journal*, September 6, 2007, 17.

these endeavors have consistently been looked upon by the U.S. military as missions to be avoided at all costs.<sup>8</sup> Even though the U.S. has spent four times the money and incurred four times the casualties during stability operations compared to major conventional operations since Vietnam,<sup>9</sup> little effort has been made to reflect this change in the Army's force structuring. Acknowledging the difficulty of stabilization missions, today's threat environment demands that the U.S. military, particularly the Army, better prepare for irregular warfare.

Recently, *Department of Defense Directive 3000.05* tasked the Army to rebalance its training and readiness focus between stability operations and conventional combat. This emphasis should force the majority of Army ground forces to question their responsibilities to perform this critical task. Yet, the Army claims the current BCT modular construct is "more than adequate to address the demands of stability operations" and is as aptly prepared for counterinsurgency as it is traditional combat operations.<sup>10</sup> Furthermore, the initial purpose and assumptions that drove today's force design are far different from the defense capabilities advocated in the 2006 *Quadrennial Defense Review*<sup>11</sup> and its supporting joint operating concepts (JOCs).

These recent policy documents prod the conventional Army to accept a greater role in counterinsurgency and foreign internal defense. While some argue it's already

---

<sup>8</sup> Dobbins, *Guide to Nation-Building*, xvii. This term refers to a belief among some strategists that the U.S. does not have an option to sit out irregular warfare conflicts in the 21<sup>st</sup> Century due to economic interdependence and the rise of transnational terrorism. The debate of whether or not the U.S. can avoid irregular warfare while sustaining its national interests is beyond the scope of this paper, however, the U.S. should prepare for it. See also, Thomas Barnett, *The Pentagon's New Map* (New York: Penguin Group, 2004); Frank Hoffman and Steven Metz, "Restructuring America's Ground Forces: Better, Not Bigger," The Stanley Foundation Policy Analyst Brief, September 2007, [http://www.stanleyfoundation.org/publications/pab/Metz\\_HoffmanPAB07.pdf](http://www.stanleyfoundation.org/publications/pab/Metz_HoffmanPAB07.pdf).

<sup>9</sup> BG Keith Walker, Deputy Director, Strategy, Plans, and Policy, HQ, Department of the Army, "Army Force Structure and Implementation of Directive 3000.05," (PowerPoint presentation given at the National Defense University and CTNSP Short Course titled, "Force Structure for Stability Operations and Interagency Integration," Fort McNair, Washington D.C., May 23, 2007).

<sup>10</sup> Andrew Feickert, *U.S. Army's Modular Redesign: Issue for Congress* (Washington D.C.: Congressional Research Service, May 2006), 6, <http://fpc.state.gov/documents/organization/67816.pdf>.

<sup>11</sup> The Office of the Secretary of Defense, *Quadrennial Defense Review Report* (Washington D.C.: Department of Defense, February 6, 2006), <http://www.defenselink.mil/qdr/report/Report20060203.pdf>.

performing these tasks in Iraq and Afghanistan,<sup>12</sup> its approach has been learn-as-you-go, and structural changes have been largely ad-hoc and inadequate. The *Irregular Warfare Joint Operating Concept (IW JOC)*<sup>13</sup> identifies a series of risks that concerns its authors. One of these is the possibility that the military (and more specifically, the Army) will fail to adequately “prepare and organize GPF (general purpose forces) for extended regional and global IW.”<sup>14</sup> To mitigate this risk, the *IW JOC* recommends that the DoD: “Conduct assessments of GPF capabilities to execute IW in the envisioned future environment. Based on these assessments, prepare a plan for Secretary of Defense approval with a timeline to address GPF capability gaps.”<sup>15</sup> This paper identifies some of the Army’s existing capability gaps and offers a conceptual force design to increase its ability to prosecute irregular warfare operations and stabilize societies.

## **B. THESIS**

The Army’s modular-brigade design being implemented today is a necessary, but incremental step that fixed strategic-mobility problems and institutionalized operational successes from the 1991 Gulf War. Today’s “transformation” does not properly prepare the Army for twenty-first century conflict.<sup>16</sup> This paper argues that infantry brigade combat teams should be better optimized for the challenges of irregular warfare through

---

<sup>12</sup> U.S. Joint Forces Command, Joint Warfighting Center, *Irregular Warfare Special Study* (Washington D.C.: Department of Defense, August 4, 2006), <http://merln.ndu.edu/archive/DigitalCollections/IrregWarfareSpecialStudy.pdf>. This study was intended to be an analysis of the 2006 QDR’s use of the term irregular warfare, its doctrinal implications, and larger implications for Joint Forces. Citing the *IW Roadmap*’s call for “US GPF to train, equip, and advise large numbers of foreign security forces,” it references Multi-National Security Transition Command (MNSTC) as evidence the concept is already being implemented. Similarly, the *IW Special Study* notes CENTCOM’s participation in Iraq as evidence of GPF performing COIN. These simplistic observations seem to state, “we’re already doing it,” without explicitly acknowledging the *Quadrennial Defense Review*’s intent of better training, organizing, and preparing GPF for these tasks in the future.

<sup>13</sup> U.S. Special Operations Command and Marine Corps Combat Development Command, *Irregular Warfare Joint Operating Concept, Version 1.0* (Washington D.C.: Department of Defense, September 2007), <http://www.fas.org/irp/doddir/dod/iw-joc.pdf>.

<sup>14</sup> “General purpose forces,” is a term used to indicate non-Special Operations Forces within the Army. They are also commonly referred to as “conventional forces.” This term is misleading as it suggests the Army is a monolithic force. Many “conventional” units have the potential to perform irregular operations.

<sup>15</sup> DoD, *IW JOC*, 37.

<sup>16</sup> The Army’s current restructuring plan is commonly termed “transformation.”

structural changes that decentralize resources, flatten the command structure, and increase the capacity and integration of intelligence personnel, mobility assets, and population-focused capabilities (such as civil affairs, information operations specialists, military police, and civil engineers) at the battalion and company level. Organizational theory, historical insights, Army doctrine, contemporary articles, presentations, and interviews are used to suggest further modifications to the force structure. Combined-arms concepts must progress beyond traditional maneuver and firepower assessments. These modified units—named within this paper as security and development brigades to distinguish them from their predecessors—would be focused on defeating guerrilla fighters, controlling (and protecting) populations, and conducting initial indigenous governance and economic capacity development.

Numerous benefits accrue by creating more autonomous, multifunctional units with the current infantry brigade combat teams as their foundation. They will have an enhanced ability to participate in steady-state multi-national partnerships and bilateral foreign internal defense (FID) operations. They will still be full-spectrum capable (in fact, establishing and maintaining a secure environment through offensive and defensive operations is still the most critical requirement), but the units would be designed with stability operations as a core mission. These units would be no more “specialized,” than a heavy brigade is for conventional warfare. This would provide a more balanced, but still tailorable force structure.

Intelligence, civil-affairs, and information operations specialists should be integrated elements of battalion and company headquarters. Military police capabilities should be expanded and also integrated into infantry battalions, but differentiated from infantry in their functions. Civil engineers and construction units should be created and integrated into security and development brigades. Having non-combat related specialists organic to the units will promote greater unit effectiveness than the current adhocism established by the brigade-modular design.

Selected Stryker brigade combat teams, Airborne, and Air Assault brigade combat teams tailored for strategic missions such as rapid deployment and forced-entry requirements would remain in their current design. The heavy brigade combat teams

would continue to be America's dominant force in major conventional operations, conflict in open terrain, and as necessary, resourced to conduct urban and population-focused operations. Limited numbers of support and functional brigades would maintain stand-alone capabilities, providing theater support and capable of detaching subordinate units to heavy brigade combat teams as necessary. Others would be absorbed into the security and development brigades. This proposal could be an incremental step. Should experimentation data and testimonies attest to the new design, similar capability designs could be implemented within heavy and Stryker brigade combat teams.

The proposed force structure would still allow security and development brigades to conduct conventional offensive and defensive operations where its small unit proficiency would be necessary to defeating an adversary in a close fight, or utilizing standoff joint air, man-portable, and indirect weapons against distant enemies. These capabilities are essential to traditional and irregular conflict, but they are not sufficient to insuring victory in today's operational environment.

### **C. OUTLINE**

This paper will progress as follows. Chapter II describes changes to the United States' threat environment and the evolving national security policies that are attempting to address those changes. Threat assessments should drive defense policies and capability assessments. Capability requirements should drive the military's force structure. This process is often overlooked during political and organizational resource competitions. Chapter III seeks to discern what assumptions and intentions led to the Army's current force design, and examines the obvious gap between the capabilities inherent to the Army's current force design (based on outdated assumptions) and those directed by more recent policy documents. Chapter IV explores a wide array of policy and structural alternatives from a variety of military analysts. Their proposals contribute to ongoing defense discussions, but have critical shortcomings, or simply do not offer enough detail from which to make meaningful policy recommendations. In many cases this paper does not refute their ideas, but builds on them. Chapter V uses organizational theory to demonstrate that recent changes in the United States' strategic environment

suggest a need to create further specialization within the force structure, and those specialists should be integrated into lower-level tactical units. Those theoretical underpinnings are then complemented with historical insights, Army doctrine, contemporary articles, presentations, and interviews to evaluate the capability and capacity of tactical units conducting irregular warfare to conduct intelligence operations, security operations, and civil-military operations. While Chapters II and III discuss strategic-level policies, this chapter analyzes tactical-level capabilities. Lastly, Chapter VI outlines a design proposal as a consideration for defense planners to modify the current modular-brigade design.

#### **D. SCOPE AND LIMITATIONS**

The scope of this thesis is limited to non-permissive environments where enemy forces employ asymmetric techniques, amongst civilian populations, in an effort to counter the technological and resource superiority of U.S. forces and their allies. In such an environment, the BCT force structure becomes a significant determinant of the capabilities of the Army to conduct numerous irregular warfare tasks. After describing an overall capability gap in U.S. defense posture, this paper pays specific attention to intelligence, security, and civil-military dimensions at the brigade and below levels of organization.

Modifications in these areas are critical to the Army's performance in irregular conflicts. Adjusting the Army's tactical force design to account for these changes would have operational-level implications, the extent of which is not fully explored within this paper. However, this analysis is based on an assumption that the Army's ground force structure should be built from the bottom up, congruent with strategic threat assessments and national security policies. This paper is limited to irregular environments, but its recommendations could be adapted with minimal impact to the Army's ability to conduct major conventional operations.

This paper does not represent an all-inclusive study of the Army's role in national security. Nor does this study account for inter-agency applications of national power and influence. Economic incentives and diplomatic initiatives should obviously precede any

foreign intervention by the United States. When military force is necessary, there is a growing awareness that military actions must be complemented with increased civilian agency capacities. Numerous conferences and studies are already exploring ways of better integrating those capabilities throughout all stages of military operations. Similarly, there is a necessary and well accepted movement to identify education and training deficiencies within the Army's workforce. For example, foreign-language training is being encouraged and the Army is promoting increased academic opportunities in economics, political science, public policy, and international relations. All of these initiatives are to be complimented. Yet, while necessary, they may not be sufficient to properly transform the Army.

Understandably, this paper will have its critics. Extensive financial and political capital has already been expended on the current design and its personnel, materiel, doctrine, and base realignment implications. Although the Army has launched numerous studies to analyze the effectiveness of its current design for irregular warfare, an over-emphasis on traditional combat operations, external influences, and internal resistance still hinders honest assessments of future force capabilities.<sup>17</sup> There is much to defend in current arrangements. As Lieutenant Colonel James Boozell, an officer in the Army's plans, policy, and experimentation department (Army G-3/5/7) acknowledged: the Army is "holding the party line for now" with regard to force structure change.<sup>18</sup> Force planners recognize the Army is in a pivotal period and are conducting continued tests and analysis, but are very unsure of what capabilities will be required beyond conflicts in Iraq

---

<sup>17</sup> This paper attempts to view tactical-level force structure through a rational perspective. However, there are numerous issues that account for force design decisions, many of which may carry more decision criteria weight than battlefield effectiveness. Senior-leader backgrounds, organizational pre-dispositions, and budgetary disputes effect force design decisions. Human resource concerns such as recruitment, retention, legacy promotion policies, and personnel allocations serve as decision limitations (sometimes with good reason, in other cases, falsely self-imposed). The effect of domestic political concerns such as research and development allocations, industrial investments, equipment acquisitions, basing allocations, and National Guard force structures also effect force structuring decisions. Lastly, the fact that organizations are largely resistant to change is well known. For further discussion of organizational change and the national security decision making process, see James Wilson, *Bureaucracy* (U.S.: Basic Books, 1989) and Graham Allison and Philip Zelikow, *Essence of Decision* (New York: Addison-Wesley, 1999).

<sup>18</sup> LTC James H. Boozell, Strategy, Policy & Integration Branch Chief, Stability Operations and Irregular Warfare Division (interview with author, October 17, 2007).

and Afghanistan. A potential (if not inevitable) foreign policy change and related defense budget allocations with a new presidential election further paralyze any bold initiatives for change.

Boozell stated that there is “no analytical data that says the ‘full-spectrum BCT’ can’t do it all.” This lack of empirical data allows senior military decision-makers to stave off criticism of the current design. However, he also admitted that irregular environments do not “lend themselves to zeros and ones” acknowledging the difficulty of establishing the kind of quantitative, predictive analysis Cold War planners were accustomed to, and the military’s modeling software is programmed for. He asked, “How do you plug in cultural differences, and social ties? How do you measure voting processes and political reconciliation? What military capabilities are needed? None of that computes.” Rather than dismiss this study for its lack of quantitative evidence, it is my hope that it can be used as a model for further simulation and field testing.<sup>19</sup> The Army’s future depends on its ability to further refine the BCT at the tactical level.

For example, manning requirements as proposed in this paper, should be derived from rational capability assessments rather than permitting current limitations and personnel policies to constrain capability analysis and force structure alternatives. A purely rational threat-based assessment is rarely used for policy and resource allocation decisions. Branch parochialism, a rigid promotion system, cultural resistance, and defense procurement initiatives contribute to create a divisive system where force structure decisions are made as a result of extensive bargaining and compromise. An Army colonel working force modernization issues for infantry brigade combat teams underscored this point when asked about the potential for increasing the number of battalions per brigade, given an anticipated increase in overall Army force size. He

---

<sup>19</sup> One source of empirical data and concept testing can be derived from OIF and OEF requirement requests from CENTCOM through Joint Forces Command to Army Forces Command. Currently, 39% of the forces in Iraq and 75% of those in Afghanistan are designer units, different from the off-the-shelf capabilities existing in the current brigade modular design. See Michelle Tan, “Deciding Who Goes, Where and When,” *Army Times*, October 14, 2007. Another influential source for future force structure decisions should be each Geographical Combatant Commander’s Theatre Security Cooperation Plans, currently framed for 2015 resource requirements. The Security Cooperation Plans should be the “analytical mark on the wall,” for force structure analysis according to Leslie Hunter, Office of the Secretary of Defense, SOLIC (interview with author, October 17, 2007).



quickly stated, “it’s not going to happen, that wouldn’t increase the number of Flag (referring to General officer) positions.”<sup>20</sup> Instead, the Army has attempted to transform its force design within an antiquated promotion system and hierarchy. The challenge is to replace the rigid promotion timelines and criteria with more flexible performance-based models needed for an updated BCT structure.

Lastly, some readers may criticize this study as a model for “fighting previous wars,” as it is weighed heavily with supporting evidence from Iraq, and to a lesser degree, Afghanistan. Iraq and Afghanistan may not provide a perfect blueprint for future operations; however, they are likely to be far more representative of future conflict than past conventional war assumptions and experiments used to validate the current force structure design. The Army cannot afford to ignore the operational lessons of recent history. Successes from the Gulf War resonated throughout the 1990s while military difficulties elsewhere were largely ignored. Continued transformation and change are needed to keep Army ground forces relevant in the future.

## **E. TERMINOLOGY**

There exists a dizzying array of terms to describe today’s military operations. For example, operations in Iraq and Afghanistan are often described by a variety of names such as post-conflict stabilization operations, counter-insurgency operations, and stability operations, highlighting the difficulty of clear naming conventions. This paper draws from sources that use many terms interchangeably to include: irregular warfare (IW), low intensity conflict (LIC), small wars, peace-keeping, counterinsurgency (COIN), stabilization and reconstruction (S&R), post-conflict stabilization, military operations other than war (MOOTW), nation-building, stability and support operations (SASO), and military support to stability, security, transition, and reconstruction (SSTR) operations. While the military attempts to articulate doctrinal differences between these terms, they are used interchangeably by academia, policy makers, civil government agencies, and non-government organizations. Although they carry recognized connotations, there is no

---

<sup>20</sup> Anonymous Colonel serving as a member of the TRADOC Capabilities Manager (question and answer session following a “Breakout Session” during the Infantry Warfighting Conference, September 19, 2007, Ft. Benning, GA).

overarching agreement on the details of their meaning. Confusion and disagreements over the use of these terms complicates an already contentious debate.

Even within the military community's regulated vernacular, multiple terms and conflicting meanings abound. A central tenet within the 2006 *Quadrennial Defense Review (2006 QDR)*, approved by the Secretary of Defense and supported by the Chairman of the Joint Chiefs of Staff, was improving Special Operations Forces (SOF) and general purpose force capabilities to conduct irregular warfare. Irregular Warfare itself is still an emerging, and debated theme within the DoD.<sup>21</sup> The 2006 *QDR* uses this term as an all-encompassing theme referring to military "activities" other than conventional combat operations against regular forces. Irregular warfare is typically protracted, conducted in an indirect manner, and focuses its operations on "a relevant population" instead of simply defeating an adversary militarily.<sup>22</sup> The *Irregular Warfare Joint Operating Concept* defines irregular warfare as "a violent struggle among state and non-state actors for legitimacy and influence over the relevant population."<sup>23</sup> IW is a broader term that encompasses COIN, stability operations, and FID.<sup>24</sup>

Since the *SSTR JOC* refers to counterinsurgency as stability operations in a hostile environment, this paper tends to interchange these terms. Since COIN is assumed to be practiced abroad by the United States in support of a foreign government, it carries a similar meaning to FID. All of these missions fall under the broader term of IW. The

---

<sup>21</sup> Five months after the *QDR* was published, the Joint Staff requested a study on the doctrinal implications of irregular warfare (Joint Forces Command, *Irregular Warfare Special Study*) resulting in a recommendation not to include the term in joint doctrine. This recommendation was rebuffed by SOCOM's, *IW JOC* which suggested that *Joint Publication 1-02* "will need to be reviewed to incorporate IW terms." Numerous additions and changes were proposed in the *IW JOC*'s glossary. The term "Irregular Warfare" is still under doctrinal dispute.

<sup>22</sup> DoD, *IW JOC*, 7.

<sup>23</sup> DoD, *IW JOC*, 4.

<sup>24</sup> According to the *IW JOC*, "insurgency and counterinsurgency are at the core of IW," while "FID is thus the external support component of counterinsurgency," and "SSTRO are an essential component of counterinsurgency campaigns (8)." It is currently not defined in the Joint Publication or Army terms references but encompasses a broad spectrum of operations other than major combat against a conventional, state enemy. Many of these operations have an operational focus that is inherently political, not military, while tactical operations focus on the population. For further discussion regarding the current doctrinal debate over Irregular War see, Chief Warrant Officer 4 Jeffrey L. Hasler, "Defining War: New doctrinal definitions of irregular, conventional and unconventional warfare," *Special Warfare Journal*, March-April (2007): 19-25.

capabilities that this paper attempts to identify with this study are similarly applicable to all three missions within the larger term of irregular warfare.

This paper may interchange some terms due their associations from varying sources, but will attempt to keep doctrinal terms in line with *Joint Publication 1-02, Department of Defense Dictionary of Military and Associated Terms*,<sup>25</sup> *Field Manual 1-02, Operational Terms and Graphics*,<sup>26</sup> and recommendations proposed in the *Irregular Warfare Joint Operating Concept*. Broadly defined, this paper is concerned with the ability of the Army's general purpose forces to conduct irregular warfare. More narrowly defined, this paper will focus on infantry and Stryker brigade combat teams conducting operations at the nexus of counterinsurgency, stability operations, SSTR, and foreign internal defense. With the stage set, the attention can now be turned to the United States' threat environment and its evolving national security strategy.

---

<sup>25</sup> Department of Defense, *Joint Publication 1-02, Department of Defense Dictionary of Military and Associated Terms*, Washington D.C.: Government Printing Office, 2001.

<sup>26</sup> Department of the Army, *Field Manual 1-02, Operational Terms and Graphics*, Washington D.C.: Government Printing Office, 2004.

THIS PAGE INTENTIONALLY LEFT BLANK

## II. AN EVOLVING NATIONAL SECURITY STRATEGY

The United States cannot force its opponents to fight the short, high-technology wars it easily dominates.<sup>27</sup>

This chapter describes post-Soviet changes to the United States' threat environment as well as the emerging national security policies, directives, and military operating concepts developed to address these changes. Looking forward, the United States envisions a world of irregular conflict, and the U.S. Army has been asked to execute missions crossing a large spectrum of operations. Senior defense leaders have set new courses for national defense in the 2005 *National Defense Strategy* and the 2006 *Quadrennial Defense Review*, directing the military to better prepare for irregular conflicts such as counterterrorism, counterinsurgency, stability operations, and foreign internal defense. The Joint Staff's recent operating concepts establish conceptual frameworks for the future operating environment between 2015 and 2027. These policies and concepts should become the Army's analytical foundation for force structure decisions. In subsequent chapters, this paper will assess whether the Army is responding with appropriate organizational adaptations.

### A. CHANGING THREAT ENVIRONMENT

We imagine the brewing threats of 'Perfect Storms' of failed governments, ethnic stratification, religious violence, humanitarian disasters, catalytic regional crises, and the proliferation of dangerous weapons. We see lagging economies, unintegrated and disenfranchised populations, transnational crime, illicit sub-national power structures, and destabilizing bulges of uneducated and unemployed youth.<sup>28</sup>

Disagreements about the force structure of the military, particularly the Army, lie first and foremost in debates over future strategic threats. Recently, there has been a growing bifurcation within the defense community between those that see U.S.

---

<sup>27</sup> Hammes, "Modern Warfare Evolves into a Fourth Generation."

<sup>28</sup> Remarks at the Joint Worldwide Planning Conference, Edelweiss Conference Center Garmisch, Germany, November 30, 2005, as quoted in the *IW JOC*, 9.

involvement in irregular war as something to avoid at all costs and therefore not taken seriously; and those that acknowledge the difficulty, but necessity to properly prepare for these conflicts. The paramount issue facing defense planners is not what sort of missions the United States military would like to conduct or avoid. But, discerning what missions it will have to perform, and performing those missions well.

Future adversaries from non-state actors to regional threats will likely utilize irregular strategies to oppose U.S. military strengths. Even if the United States' Army continues to weigh its resources against the potential rise of a conventional competitor, the Army must not only prepare for major combat operations, but the post-conflict stabilization requirements that would follow. Unlike the relatively stable environments of post-conflict Italy, Germany, and Japan, the likelihood of post-conflict instability will continue to exist in the foreseeable future.<sup>29</sup> The Army must develop doctrine and organizations that cover transitions from invasion, major combat, and protracted irregular warfare.

## **1. Visions of the Future**

In the 1990s while the U.S. military continued to train against Soviet-based doctrine, a quiet but growing audience began to question the nature of future threats.<sup>30</sup> Martin Van Creveld's, *The Transformation of War*<sup>31</sup> described recent changes in the nature of military conflict and the future of warfare. Van Creveld argued that conventional warfare between states was being replaced with the tactics of guerrilla war

---

<sup>29</sup> Increased weapons proliferation and communications have increased the destructive capabilities of guerrillas. Additionally, some analysts suggest that increased operational fidelity and precision targeting can leave much of an invaded country in tact, allowing resources for guerrilla warfare. Whereas, strategic bombing campaigns and massed conflict between large armies increased the suffering of indigenous populations making them less susceptible to conduct armed resistance against occupying powers.

<sup>30</sup> See also, Max G. Manwaring ed., *Uncomfortable Wars, Toward a New Paradigm of Low Intensity Conflict* (Boulder: Westview Press, 1991).

<sup>31</sup> Martin Van Creveld, *The Transformation of War: The Most Radical Reinterpretation of Armed Conflict Since Clausewitz* (New York: The Free Press, 1991).

and terrorism employed by non-state actors. He warned “strong” states to be wary of “weak” ones and to recognize the asymmetric nature of low intensity conflict.<sup>32</sup>

Thomas Hammes built on Van Creveld’s work when he popularized the term “fourth generation warfare” (4GW).<sup>33</sup> 4GW represents an emergence of unconventional opponents who fight across the spectrum of “political, social, economic, and military networks.” To combat worldwide networks of 4GW opponents, Hammes argued for “major changes in the way we educate, employ, structure, and train forces.” In 2004 he expanded on his earlier work, providing a critical analysis of the military’s bureaucracy and its failure to adjust its organizations, tactics, and training to appropriately defeat today’s threats.<sup>34</sup> While he notes the obvious benefits of technological development, he believes current research priorities are misplaced with an emphasis on technological networks (net-centric warfare) instead of human ones. Hammes notes sunk costs, staffs, promotion and procurement systems that have contributed to “an entire culture and industry built around second- and third-generation warfare (conventional, combined arms maneuver).”<sup>35</sup> Both Hammes and Van Creveld forewarned a future threat environment where stability operations, counterinsurgency, and counterterrorism would become predominant.

Published almost concurrently with Hammes’ earlier work, Robert Kaplan’s “Coming of Anarchy,”<sup>36</sup> foreshadowed a similar future. Today, his assessment deserves

---

<sup>32</sup> Numerous authors have explored this subject. Most recently, Ivan Arreguin-Toft, *How the Weak Win Wars* (England: Cambridge University Press, 2005), uses extensive historical empirical evidence to suggest a simple model for conflict titled, “Strategic Interaction Theory.” The essence of the argument is that strong and weak opponents can pursue regular or irregular warfare strategies. When opponents adopt the same strategy (symmetric warfare), the strong win. In cases where they adopt different strategies (asymmetry), the weak win.

<sup>33</sup> “4<sup>th</sup> Generation Warfare” was coined by Thomas X. Hammes, “The Evolution of War: The Fourth Generation,” *Marine Corps Gazette*, September, 1994, <http://www.d-n-i.net/fcs/hammes.htm>.

<sup>34</sup> Thomas X. Hammes, *The Sling and the Stone, On War in the 21<sup>st</sup> Century* (Minnesota: Zenith Press, 2004). Hammes outlines an “evolved form of insurgency,” where adversaries utilize “all available networks—political, economic, social, and military—to convince the enemy’s political decision makers that their strategic goals are either unachievable or too costly for the perceived benefit (208).” Hammes’ critics note that his self-described 4GW is not a new phenomenon, but an asymmetric form of conflict that has reappeared throughout history. Despite questions of semantics, his ideas are extremely insightful.

<sup>35</sup> Hammes, *The Sling and the Stone*, 201.

<sup>36</sup> Robert D. Kaplan, “The Coming Anarchy,” *The Atlantic Monthly*, February 1994, <http://www.theatlantic.com/doc/prem/199402/anarchy>.

more attention than it was once given. To understand conflict over the next fifty years, he stated, “one must understand environmental scarcity, cultural and racial clash, geographic destiny, and the transformation of war.” He cites a world population booming from 5.5 billion to more than 9 billion, the depletion and/or degradation of natural resources, and population movements that will breed crime and fuel existing hatreds such as those described by Samuel Huntington.<sup>37</sup> Kaplan warns of a growing militant tract of Islamic extremism that “makes it attractive to the downtrodden,” and he declares, “it is the one religion that is prepared to fight.” As the influence of Islam spreads, the governing legitimacy of many African, Middle East, and Southeast Asian states declines. Kaplan envisioned our multi-colored globes of clearly defined nation-states being “replaced by a jagged-glass pattern of city-states, shanty-states, nebulous and anarchic regionalisms.”

Amongst this chaos, there is a host of areas where the U.S. could find itself intervening (multilaterally, or unilaterally if necessary) and in need of capabilities more indicative of irregular than conventional combat.<sup>38</sup> The collapse of a large state such as Indonesia or Pakistan (with the latter possessing nuclear weapons), providing assistance to an ally against an aggressor state in Africa, or conducting a future proxy war with Russia or China in central Asia will unlikely display symptoms of the linear, high-tech, platform-based combat that shaped current resource and organizational imperatives.

As the economic gap grows between information-age states and many pre-industrial societies, citizens of the latter will become more inclined to rebel against weak or corrupt states and other sources of injustice.<sup>39</sup> Increasingly, the divide between

---

<sup>37</sup> Samuel P. Huntington, “The Clash of Civilizations,” *Foreign Affairs*, vol. 72, no. 3 (Summer 1993), <http://www.alamut.com/subj/economics/misc/clash.html>.

<sup>38</sup> Examples derived from Andrew Krepinevich, Nadia Schadlow, and Marin J. Strmecki, “Stability, Security, Transition, and Reconstruction Operations: Meeting the Challenge” (PowerPoint presentation dated March 7, 2007, emailed to the author). Similar examples can be read in Metz and Hoffman, “Restructuring America’s Ground Forces: Better, Not Bigger.”

<sup>39</sup> Known as “relative deprivation,” it is in part, due to “rapidly rising expectations, nourished by images of affluence and democratic lifestyles spread by the international mass media, have fueled feelings of deprivation among vast populations.” See, Fathali M. Moghaddam, “The Staircase to Terrorism, A Psychological Exploration,” *American Psychologist*, vol. 60, no. 2 (February-March 2005), 161-169. See also, Marc Sageman, *Understanding Terror Networks* (Philadelphia: University of Pennsylvania Press, 2004).



political insurgents and criminal opportunists is becoming harder to discern as both cite religious ideology or government neglect as their cause *de jure*. The proliferation and size reduction of explosives, weapons, and the potential for biological contaminants makes suicide zealots particularly dangerous. On a global level, disparate groups are becoming increasingly networked through information technologies, rallying around similar grievances or shared enemies. At the local level, many of these groups maintain closely-guarded relationships in traditional social networks that can not be easily penetrated.<sup>40</sup> These struggles may be less technological, but have the potential to be as devastating as the high-tech conventional wars the U.S. Army has prepared itself for in the past.

In 1994, Congress directed a review of the “current allocations of roles, missions, and functions among the Armed Forces.”<sup>41</sup> Their commission’s report indicated the possibility of peace operations increasing in frequency and intensity, and as such, the need for appropriate U.S. capabilities.<sup>42</sup> It made numerous recommendations to include the following: 1) “assign proper priority to peace operations” through changes in DoD directives and planning guidance; 2) review related training programs and equipment stocks; 3) “integrate other agency resources”; 4) and “determine how best to organize DoD and non-DoD assets to conduct these operations.”<sup>43</sup> Furthermore, the report recommended that the Secretary of Defense propose to the National Security Council a Presidential Directive that integrates inter-agency, contractors, and non-governmental organizations into peace operations.<sup>44</sup> This suggestion finally took root with the release of *National Security Presidential Directive 44* and *DoD Directive 3000.05* in 2005, ten

---

<sup>40</sup> Sageman, *Understanding Terror Networks*. Sageman emphasizes the role of societal networks over top-down organizational strategies for explaining terrorist recruitment initiatives.

<sup>41</sup> “National Defense Authorization Act for Fiscal Year 1994,” PL 103-160, 30 November 1993 (as amended), as stated in, The Commission on Roles and Missions of the Armed Forces, John P. White, Chairman, *Directions for Defense, The Department of Defense Report* (Washington D.C.: Brassey’s, 1995).

<sup>42</sup> Peace operations as defined in the 1995 *Directions for Defense Report* are those missions to “prevent, halt, or contain conflict” other than major, regional combat operations. Despite its name, the terminology is not meant to indicate a permissive threat environment and can be considered synonymous with today’s stability or counterinsurgency operations.

<sup>43</sup> Commission on Roles and Missions, *Directions for Defense Report*, 2-16, 2-17.

<sup>44</sup> Commission on Roles and Missions, *Directions for Defense Report*, 2-19.

years and four conflicts later.<sup>45</sup> As such, there is no indication that the report's suggestions were heeded when the Army designed its current force structure.

However, the visions of Van Creveld, Kaplan, Hammes, and others have finally become established policy. Today, one of the most commonly used diagrams found throughout current DoD policy documents and presentations is the following quadrant chart (see Figure 1).<sup>46</sup> Unveiled in the 2006 *Quadrennial Defense Review*, it establishes a conceptual visualization of the challenges the United States is expected to face in the twenty-first century:<sup>47</sup>

- Traditional challenges posed by states employing conventional armies, navies, and air forces in well-established forms of military competition.
- Irregular challenges from state and non-state actors employing methods such as terrorism and insurgency to counter our traditional military advantages, or engaging in criminal activity such as piracy and drug trafficking that threaten regional security.
- Catastrophic challenges involving the acquisition, possession, and use of WMD by state and non-state actors; and deadly pandemics<sup>48</sup> and other natural disasters that produce WMD-like effects.
- Disruptive challenges from state and non-state actors who employ technologies and capabilities (such as biotechnology, cyber<sup>49</sup> and space operations, or directed-energy weapons) in new ways to counter military advantages the United States currently enjoys.

---

<sup>45</sup> See, George Bush, National Security Presidential Directive/NPSD 44, December 7, 2005, <http://www.fas.org/irp/offdocs/nspd/nspd-44.html>. This memorandum was issued to improve “coordination, planning, and implementation for reconstruction and stabilization assistance for foreign states and regions at risk of, in, or in transition from conflict or civil strife.” It is largely viewed as a catalyst for developing an interagency approach to stabilization operations. The document assigns lead to the State Department for stabilization and reconstruction activities, creating the office of the Coordinator for Reconstruction and Stabilization (S/CRS).

<sup>46</sup> See, DoD, *QDR 2006*; BG Andrew B. Twomey, “Cost of Modern War,” (PowerPoint presentation dated January 5, 2006); and DoD, *IW JOC*, 11.

<sup>47</sup> Paraphrased from, Office of the President of the United States, *The National Security Strategy of the United States of America* (Washington D.C.: March, 2006), 44; and The Office of the Chairman of the Joint Chiefs of Staff, *Capstone Concept for Joint Operations, v 2.0* (Washington D.C.: Department of Defense, August, 2005), 6, [http://http://www.dtic.mil/futurejointwarfare/concepts/approved\\_ccjov2.pdf](http://http://www.dtic.mil/futurejointwarfare/concepts/approved_ccjov2.pdf).

<sup>48</sup> See, Thomas X. Hammes, “Fourth Generation Warfare Evolves, Fifth Emerges,” *Military Review*, May-June (2007), 14-23.

<sup>49</sup> See, Gabriel Weimann, *Terror on the Internet* (Washington D.C.: United States Institute of Peace Press, 2006).

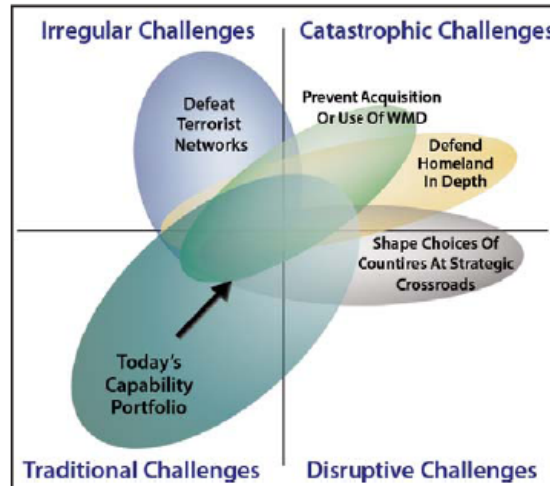

Figure 1. The Changing Threat Environment

## 2. Weighing Risk

Most of the national security policy documents today call for the military, namely the Army, to be better capable of combating irregular opponents. However, a frequent caveat within defense policy documents is that the military cannot sacrifice its ability to deter, and if necessary conduct major conventional combat operations. Though necessary, this has led to peripheral changes to the Army’s force design, providing marginal enhancements to better its performance at stability operations without giving up its ability to do what it does best—large scale conventional combat operations. While procurement budgets may be finite, force structure options are not necessarily a zero-sum game. The potential need exists to make the Army, or major elements of it, optimal for irregular conflict, while remaining capable of conducting conventional operations overseas.

Critics of the Army’s present-day philosophical emphasis on counterinsurgency and stability operations point towards Iran, China, North Korea, and Russia as potential conventional threats to be wary of in the future. Numerous strategists and military leaders see irregular warfare as a passing fancy. They believe difficulties in Iraq are the ghosts of poor planning and idealized foreign policy—mistakes never to be made again. One senior defense planner called counterinsurgency “passe,” saying it would be a once-

again forgotten concept once the military can free itself of Iraq and Afghanistan.<sup>50</sup> In a recent speech to the National Press Club, the Army's Chief of Staff General George Casey described the Army as "unbalanced." "Right now we're focused on counterinsurgency training. We need to get back to full-spectrum training as soon as we can," he said, a statement many of his listeners assumed to mean placing a greater emphasis back on conventional combat.<sup>51</sup> While trainers at the Army's Joint Readiness Training Center say many leaders and staffs on the eve of their combat deployments still lack anything but a rudimentary understanding of counterinsurgency and the staff processes to help fight it,<sup>52</sup> the Army's senior officer is advocating a pendulum shift back towards traditional combat training—a change, even if it is irrelevant and counter-productive to the conflicts at hand and those in the foreseeable future.

Army documents consistently describe traditional warfare as the least likely, but most dangerous threat to American interests abroad. The 2005 *Capstone Concept for Joint Operations*, version 2.0 acknowledges that the U.S. lead in traditional military power "nullifies the incentive of a potential opponent to compete with us." Most analysts agree that the U.S. should maintain its dominance in this regard, however the U.S. can not continue to suffer painful losses in what are often perceived as "lesser wars."

Should the U.S. Army have to engage a rival state such as Iran, China, North Korean, or Russia in future warfare, there is little reason to believe the ground battlefield would look like those of the 1940s and 50s. Provided the U.S. maintains its dominance of the air and naval lanes, there is little likelihood rival states would desire to engage in traditional maneuver warfare. Recognizing U.S. political fickleness and military vulnerabilities displayed in Vietnam, Beirut, Somalia, Iraq, and Afghanistan, future enemies may be more likely to execute a deliberate guerrilla campaign. Countries such as Iran will be more likely to hug their cities and populations, using a combination of conventional platforms and irregular fighters if attacked, while attempting to employ

---

<sup>50</sup> Lieutenant Colonel from Joint Forces Command who wished to remain anonymous (conversation with the author at a counterinsurgency seminar, March 14, 2007, Westpoint, N.Y).

<sup>51</sup> Gina Cavallaro, "Casey Urges More Conventional Training," *Military Times*, August 17, 2007, [http://www.militarytimes.com/news/2007/08/army\\_casey\\_070814w/?fromrss=1](http://www.militarytimes.com/news/2007/08/army_casey_070814w/?fromrss=1).

<sup>52</sup> Major (P) Andy Ulrich, IN, U.S. Army (phone interview, August 22, 2007).

terrorist tactics against the U.S. and its allies' interests abroad.<sup>53</sup> Strategist Thomas Hammes is adamant about this last point:

Every potential opponent has observed the Gulf War, Operation Iraqi Freedom, and operations in Afghanistan. They understand that if the United States is provided clear targets, no matter how well fortified, those targets will be destroyed. Just as certainly, they have seen the success of the Somalis and the Sandinistas. They have also seen and are absorbing the continuing lessons of Chechnya, Bosnia, Afghanistan, and Iraq. They will not fight with conventional means.<sup>54</sup>

Let there be no mistake, a conventional hedge must be maintained against potential regional conflict with countries such as China as long as it continues to expand its military capabilities in a non-transparent way and seek to “lock up” energy markets around the world.<sup>55</sup> When referencing China’s future military strategy, most defense planners discuss “unrestricted warfare,” based on a popular paper written by Qiao Liang and Wang Xiangsui of the People’s Republic of China. Liang and Xiangsui describe a multi-pronged military strategy “with nothing forbidden” to include cyper-warfare, attacking the networks of financial institutions, terrorism, and urban guerrilla warfare.<sup>56</sup> Force planners fearful of China point to the Chinese missile test against one of their low-flying weather satellites on January 11, 2007, and a Chinese submarine that allegedly “stalked” a U.S. Navy fleet on October 26, 2006.<sup>57</sup>

---

<sup>53</sup> Iran’s use of proxies in Iraq is well documented and reported. For example, see Simon Tisdall, “Iran’s Secret Plan for Summer Offensive to Force U.S. Out of Iraq,” *The Guardian*, May 22, 2007, [http://www.guardian.co.uk/frontpage/story/0,,2085195,00.html#article\\_continue](http://www.guardian.co.uk/frontpage/story/0,,2085195,00.html#article_continue). Also, Associated Press, “U.S.: Iran Smuggling Missiles and Other Advanced Weapons into Iraq,” *FoxNews.Com*, September 24, 2007, <http://www.foxnews.com/story/0,2933,297777,00.html>.

<sup>54</sup> Hammes, “Modern Warfare Evolves into a Fourth Generation.”

<sup>55</sup> The Office of the President, *The National Security Strategy*, 41.

<sup>56</sup> Qia Liang and Wang Xiangsui, *Unrestricted Warfare* (Beijing: PLA Literature and Arts Publishing House, February 1999), 2. As referenced by Hasler, “Defining War.” See also, Hammes, *The Sling and the Stone*.

<sup>57</sup> The intentions, meanings, and policy implications of these two events are largely debated. For initial unclassified reporting, see Marc Kaufman and Dafna Linzer, “China Criticized for Anti-Satellite Missile Test,” *Washington Post*, January 18, 2007, <http://www.washingtonpost.com/wp-dyn/content/article/2007/01/18/AR2007011801029.html>; and Bill Gertz, “China sub secretly stalked U.S. fleet,” *The Washington Times*, November 13, 2006, [http://extendedremarks.blogspot.com/2006\\_11\\_13\\_archive.html](http://extendedremarks.blogspot.com/2006_11_13_archive.html).

Despite these ongoing tensions with the communist country, it is hard to imagine decisive tank on tank warfare in eastern Asia. Instead, “the strategies of our adversaries will be to subvert, attrite, and exhaust us rather than defeat us militarily.”<sup>58</sup> Conflict with China will likely take place in the financial markets or cyper-space. Yet, it will be necessary to maintain significant capital-intensive expenditures to protect the U.S. lead in maritime, air, space, and digital domains, if only as a deterrence strategy.<sup>59</sup>

Additionally, should the U.S. face Iran, China, North Korea, or Russia in future conventional warfare, the challenges of post-conflict stabilization<sup>60</sup> will likely still exist. As demonstrated in Iraq, war does not end when the last enemy tank is destroyed. The U.S. cannot hope for future armistice treaties. The Army must truly institutionalize tactics, doctrine, and organizational lessons being learned in Afghanistan and Iraq today.

## **B. POLICY FORMULATION**

The 9/11 attacks and post-invasion difficulties in Iraq and Afghanistan have awakened the U.S. government to the realities of twenty-first century threats. This has resulted in numerous policy changes and national security directives that encourage further changes within the Army beyond “transformations” initial blueprint.

### **1. The Quadrennial Defense Review**

The 2005 *National Defense Strategy* encouraged defense planners to redefine past conceptions of general purpose forces, noting: “our [U.S.] experiences in the war on terrorism points to the need to reorient our military forces to contend with such irregular challenges more effectively.”<sup>61</sup> The 2006 *Quadrennial Defense Review (QDR)* took this guidance and sought ways for DoD capabilities to shift their emphasis to better prepare

---

<sup>58</sup> DoD, *IW JOC*, 15.

<sup>59</sup> Hammes, *The Sling and the Stone*.

<sup>60</sup> Refers to the initial necessity to provide order, reconstitute essential services, reestablish governance and law, and provide the essential foundations for economic development. U.S. involvement within a large-scale contingency could be as a supporting effort in a multilateral coalition, but will likely take a leading role when the situation demands it.

<sup>61</sup> The Office of the Secretary of Defense, *The National Defense Strategy of the United States of America* (Washington D.C.: Department of Defense, March 2005), [http://www.globalsecurity.org/military/library/policy/dod/nds-usa\\_mar2005.htm](http://www.globalsecurity.org/military/library/policy/dod/nds-usa_mar2005.htm).

for a host of emerging threats. The *QDR* notes that “U.S. forces are primarily organized, trained, educated, and equipped for traditional warfighting,” acknowledging the need to maintain such functions in the event of major conventional warfare. However, the *QDR* also recognizes that military forces are not as capable of conducting protracted IW in the current or envisioned threat environments and recommends “rebalancing general purpose forces” to improve their capability to operate against adversaries who are attempting to, or already have mobilized their populations against us.<sup>62</sup> Specifically, the *QDR* recognizes the need for “multipurpose forces to train, equip, and advise indigenous forces; deploy and engage with partner nations; conduct irregular warfare; and support security, stability, transition, and reconstruction operations.”<sup>63</sup>

The 2006 *QDR* makes a stark contrast to its 2001 predecessor. The 2001 *QDR* directed the DoD to design its force structure to “swiftly defeat” enemies in two military campaigns, winning one of them “decisively.” It also acknowledged the need to conduct a “limited number of *lesser* military and humanitarian contingencies.”<sup>64</sup> That same year, President Bush came to office proclaiming the U.S. would not get involved in nation-building.<sup>65</sup> However, the attacks of 9/11 reshaped U.S. foreign-policy, and led to a realization that the U.S. military was ill-prepared for the potential future.

The 2006 *QDR* addresses this gap. In the 2006 edition, the “lesser” types of contingencies became the focal point and “decisive” campaigns were replaced with an emphasis on “distributed, long-duration operations.” The ability to compete in conventional campaigns became overshadowed by a desperate need to develop

---

<sup>62</sup> DoD, *IW JOC*, 11; DoD, *QDR 2006*.

<sup>63</sup> DoD, *QDR 2006*, 23.

<sup>64</sup> The Office of the Secretary of Defense, *Quadrennial Defense Review Report*, (Washington D.C.: Department of Defense, September 30, 2001), <http://www.defenselink.mil/pubs/pdfs/qdr2001.pdf>. (emphasis added)

<sup>65</sup> During a Bush-Gore presidential debate in Winston-Salem, North Carolina on October 11, 2000, Bush criticized President Bill Clinton’s foreign policy in Somalia and Haiti, stating, “I don’t think our troops ought to be used for what’s called nation-building,” distinguishing peace-enforcement missions from what he believed the central purpose of the military should be, to “fight and win war.” Bush then elaborated, “I think our troops ought to be used to help overthrow a dictator that’s in our and its in our best interests.” (<http://www.cbsnews.com/stories/2000/10/11/politics/main240442.shtml>) President Bush’s administration has been frequently criticized for underestimating the scale and duration of nation-building requirements in Iraq and Afghanistan (particularly Iraq), after their governments were overthrown.

capabilities for unconventional warfare, FID, counterinsurgency, and stabilization operations.<sup>66</sup> With the new guidance in place the Department of Defense should have refined its force planning construct. But curiously, the *QDR* compliments the Army's ongoing force structure change which was designed in accordance with the *2001 QDR's* emphasis on decisive conventional campaigns—a subject the next chapter will explore in greater detail. The modular brigade's force design has been relatively unscathed despite ongoing discussions to make general purpose ground forces more tailored to irregular environments.

## 2. DoD Directive 3000.05

*DoD Directive 3000.05* was signed on November 28, 2006 to establish “DoD policy and assigns responsibilities within the Department of Defense for planning, training, and preparing to conduct and support stability operations...”<sup>67</sup> The directive defines military support to SSTR as those DoD activities “that support U.S. Government plans for stabilization, security, reconstruction and transition operations, which lead to sustainable peace while advancing U.S. interests.”<sup>68</sup> Stability operations are broadly defined as “military and civilian activities conducted across the spectrum from peace to conflict to establish or maintain order in States and regions.”<sup>69</sup> Paragraph 4.1 states:

[Stability operations] shall be given priority comparable to combat operations and be explicitly addressed and integrated across all DOD activities including doctrine, *organizations*, training, education, exercises, material, leadership, personnel, facilities, and planning.<sup>70</sup>

The directive correctly places heavy emphasis on civil-military partnerships and inter-agency organizations, foreign government and security force integration, cooperation with U.S. and foreign nongovernmental organizations, and the private sector.

---

<sup>66</sup> DoD, *2006 QDR*, 36.

<sup>67</sup> Gordon England, “Military Support for Stability, Security, Transition, and Reconstruction (SSTR) Operations,” *Department of Defense Directive 3000.05* (November 28, 2005), 1.2, <http://www.dtic.mil/whs/directives/corres/pdf/300005p.pdf>.

<sup>68</sup> *DoD Directive 3000.05*, 3.2.

<sup>69</sup> *DoD Directive 3000.05*, 3.1.

<sup>70</sup> *DoD Directive 3000.05*, 4.1 (emphasis added).



However, the directive assigns the U.S. military responsibility to perform “all tasks necessary to establish or maintain order when civilians cannot do so.”<sup>71</sup> This tasking results from the realization that civil assistance is limited while hostilities continue. The presence of non-state terrorists, intra-state insurgents, violent militias, and criminal elements will continue to present the major impediment to U.S. stability efforts. Those efforts may follow major combat operations, U.S. interdictions against inter-state and intra-state violence that threatens regional stability, disastrous humanitarian crisis, and other U.S. interests abroad. Paragraph 1.3 claims that *DoD Directive 3000.05* “supersedes any conflicting portions of existing DoD issuance.” This should include the current modular brigade design.

### **3. Joint Operating Concepts**

While the *2006 QDR* establishes a defense strategy, and *DoDD 3000.05* establishes a mandate, the *Military Support to Stabilization, Security, Transition and Reconstruction Operations (SSTR JOC)*, *Joint Operating Concept* and the *Irregular Warfare Joint Operating Concept* establish a guide for future strategy design, doctrine, and force structure. While these operations share many commonalities, certain ones are more indicative of one environment over another. This paper is identifying capabilities that are required in the ambiguous nexus of irregular warfare, major combat operations (MCO), and SSTR operations. The area is conceptually displayed in Figure 2.<sup>72</sup>

---

<sup>71</sup> *DoD Directive 3000.05*, 4.3.

<sup>72</sup> Modified from the *IW JOC*, “JOC Relationships,” 13.

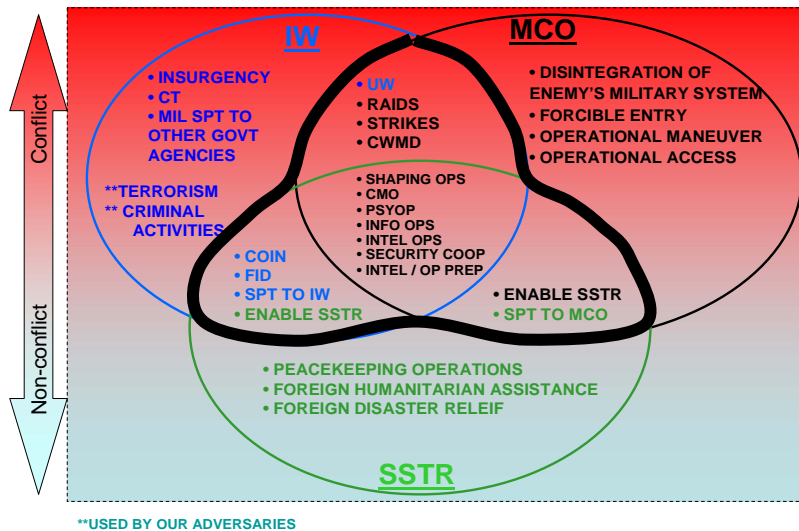

Figure 2. Conceptual Linkages

Written in December 2006, the *SSTR JOC* “posits an operational level solution for a very challenging future military problem—how the Joint Force can more effectively prepare for and conduct SSTR operations to assist governments or regions under serious stress.” The document seeks to identify capabilities for future SSTR operations, and establishes a recognized framework for further Defense Department experiments and simulations. Within a conceptual timeframe of 2014-2026, the *SSTR JOC* claims to represent a launch point for future doctrine, organization, training, materiel, leader development and education, personnel, and facility (DOTMLPF) changes associated with military support to SSTR operations. The *SSTR JOC* establishes six major missions of a SSTR Operation at the operational level as depicted in Figure 3 below.<sup>73</sup>

<sup>73</sup> U.S. Joint Forces Command, *Military Support to Stabilization, Security, Transition, and Reconstruction Operations Joint Operating Concept, Version 2.0* (Washington D.C.: Department of Defense, December 2006), iv, [http://www.dtic.mil/futurejointwarfare/concepts/ssstro\\_joc\\_v20.doc](http://www.dtic.mil/futurejointwarfare/concepts/ssstro_joc_v20.doc).

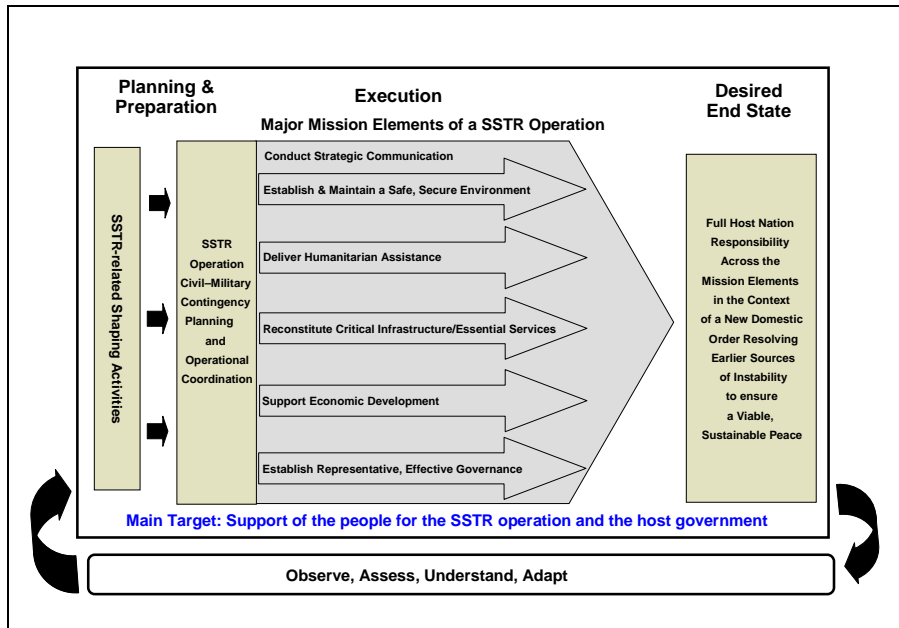

Figure 3. Operational Lines of SSTR

The *SSTR JOC* claims to establish operational concepts within the broader guidelines of *DoDD 3000.05* and *NSPD 44*. Relevant to this study, the *SSTR JOC* cites “high end” SSTR as those “operations associated with a U.S. imposed regime change, assisting a faltering government or responding to the collapse of a government caused by internal failure or military defeat.” When this situation includes the presence of threatening armed forces opposing the host government, this type of SSTR is a counterinsurgency operation.<sup>74</sup>

The finer details of the *SSTR JOC* showcase a continuous source of friction within the military community. Some members of the armed forces are still resistant to adopt certain “civilian responsibilities” in a conflict environment. The *SSTR JOC* consistently states civilian agencies and organizations “will” take the lead in stabilization missions instead of “should” and calls on the creation of an operational civilian core. But the document provides an early disclaimer about the lack of civilian capabilities and twice writes a “high risk” warning about civilian capabilities not arriving in the quantity or for the longevity needed in an SSTR environment abroad. The military must improve its

<sup>74</sup> DoD, *SSTR JOC*, iv.

ability to coordinate efforts with civilian agencies abroad, oftentimes in a supporting capacity. However, until significant reforms are made throughout the inter-agency, the least bit of which is a legal mandate to serve in hostile assignments when directed (similar to the Uniformed Code of Military Justice), service members will have to expect to carry the propensity of effort in a hostile or semi-permissive environment. The question is whether they are prepared to do so?

The *Irregular Warfare Joint Operating Concept* identifies a common framework for tasks the military must perform that are radically different from conventional combat operations. It lists fourteen activities belonging to the concept of irregular warfare: insurgency; counterinsurgency; unconventional warfare; terrorism; counterterrorism; foreign internal defense; stability, security, transition and reconstruction operations; strategic communications; psychological operations; civil-military operations; information operations; intelligence and counterintelligence activities; transnational criminal activities; and law-enforcement activities countering irregular adversaries.<sup>75</sup>

While some of these operations have historically been the hallmarks of Special Operations units, the *2006 QDR* is calling on general purpose forces (GPF) to assume a larger role in some of these tasks to include, COIN, FID, and SSTR. Without a doubt many of these activities are inter-related. Specifically the *IW JOC* expands GPF capability requirements as follows:

- Provide a greater number of small units operating in a distributed manner throughout a potentially large operational, working unilaterally, or with partners. (This concept is similar to that of joint net-centric warfare, only IW is the type of warfare, not conventional operations).
- Prepare to conduct COIN, operating “amongst the people.”
- Train and advise indigenous forces in IW operations.
- Establish interim military government or perform civil administration functions in occupied or liberated territory when indigenous, international, or US civilian agencies cannot do so.

---

<sup>75</sup> This list includes both U.S. and our adversary’s “activities.” Terrorism and criminal activities are explicitly listed as being “used by our adversaries.” (See Figure 2).

In the 1990s, Martin van Creveld's *Transformation of War*, was a must read within the Pentagon. His concepts were reinforced in 2003 with Thomas Hammes' *Sling and the Stone*, almost a mandatory read on most military professional reading lists. After 9/11 and years of difficulties in Afghanistan and Iraq, their visions of the future threat environment have been embodied by recent policy documents and directives. What remains to be seen is how suited the Army's current force structure is to these changes. In subsequent chapters, this paper will determine if the Army is responding fast enough to today's environment with appropriate organizational adaptations. The evidence suggests not.

THIS PAGE INTENTIONALLY LEFT BLANK

### **III. THE ARMY’S RESPONSE—“TRANSFORMATION”**

The previous chapter discussed traditional and irregular threat concepts under consideration by military planners. It outlined strategy and policy changes that should be the impetus for the Army’s force structure decisions. This chapter describes the Army’s current force structure and shows how it came to be. First, an overview of the revolution in military affairs (RMA) discussions and their theoretical underpinnings establish a foundation on which to better understand the assumptions that led to the Army’s current modularity design. Second, an overview of the more current transformation planning and policy documents will articulate the intent behind the Army’s latest organizational design, the brigade combat Team (BCT). A description of the BCT design will identify capability gaps when the BCTs are tasked to conduct irregular operations such as counterinsurgency and stability operations.

#### **A. THE REVOLUTION IN MILITARY AFFAIRS**

Post-Cold War changes in international relations, a changing threat environment, and an explosion of technological innovations in the 1980s led to frequent debates since the 1990s about the use of technology in the military. Actual and potential improvements in information technologies, precision weapons, armor, and robotic capabilities have launched a theoretical movement known as the revolution in military affairs. Not only did the defense community respond with ideas of warfare altered by technological dominance, but it looked to exploit technology to keep U.S. power projection relevant in a post-Soviet era.

The 1991 Gulf War demonstrated the mobility and lethality of an increasingly digitized battlefield in the vast desert of Kuwait and southern Iraq. Advanced communications, global positioning systems, and precision weapons demonstrated the formidable power of air-ground coordination in an increasingly joint, combined-arms fight. However, the lack of available pre-positioned forces in the region resulted in an extensive and time-consuming build-up prior to the initiation of ground combat. Meanwhile, light infantry soldiers from the 82<sup>nd</sup> Airborne Division were temporarily

holding a defensive line, exposed to the threat of Iraq's heavier and larger ground forces. Preparations for the Gulf War revealed a weakness in United States' ability to project military force abroad.

For decades, the U.S. military remained postured for potential ground combat in Europe and eastern Asia against the U.S.S.R. When the Soviet Union collapsed, the U.S. government responded with a "peace dividend" by way of a reduction in military size and spending. Worldwide base realignments and closures throughout the 1990s reduced the size of pre-positioned military forces abroad. Additionally, battle plans designed for mobile conventional ground combat in the Fulda Gap or the Korean peninsula gave way to a new host of potential contingencies.

The U.S. became increasingly involved in third-world conflicts where pre-positioned equipment was unavailable and countries of interest lacked the infrastructure to support heavy vehicle movement.<sup>76</sup> Not knowing where U.S. forces would be called to in the future, defense planners sought ways to increase U.S. strategic mobility and reduce logistics requirements for rapid deployment forces. Transformation initiatives explored lighter platforms and improvements for ground and sea mobility. Besides mobility platforms, futurists foresaw information technologies as a combat multiplier that could revolutionize Army tactics.

Of the numerous scholars calling for major changes in military strategy and force structure throughout the 1990s, perhaps none were as influential as Douglas Macgregor and Arthur Cebrowski. Macgregor's *Breaking the Phalanx* argued for changes to the Army's legacy structure of corps and division-level fighting formations.<sup>77</sup> His thesis called for the reorganization of the Army into mobile combat groups pre-positioned throughout the world, postured to conduct "rapid and decisive" operations relying on "superior knowledge" and "information dominance." Vice Admiral Arthur Cebrowski

---

<sup>76</sup> H.R. McMaster, "A Crack in the Foundation: Defense Transformation and the Underlying Assumption of Dominant Knowledge in Future War" (Student issue paper, CSL, U.S. Army War College, vol. S03-03, November 2003). McMaster references mobility problems during the initial phase of Operation Desert Shield (lack thereof), in Somalia (lack of armored vehicles), and Kosovo (lack of appropriate type).

<sup>77</sup> Douglas A. McGregor, *Breaking the Phalanx: A New Design for Landpower in the 21st Century* (Westport, CT: Praeger, 1997).



echoed similar concepts of speed, precision, and information superiority in his 1998 *Proceedings* article that popularized the term “network-centric warfare” (NCW).<sup>78</sup> Both authors were invaluable catalysts of change within the defense community and their ideas carry significant merit; however, neither author gave much attention to the possible difficulties of post-conflict stability operations, counterinsurgency, and elements of irregular warfare that affect U.S. Army ground forces today. Macgregor, Cebrowski, and other theorists were proposing revolutionary ways of fighting traditional military adversaries.

## **B. ARMY TRANSFORMATION**

### **1. A Three-Pronged Strategy**

On October 12, 1999, Army Chief of Staff General Eric K. Shinseki announced the formal initiation of the Army’s transformation plan.

To adjust the condition of the Army to better meet the requirements of the next century, we articulate this vision: ‘Soldiers on point for the nation transforming this, the most respected army in the world, into a strategically responsive force that is dominant across the full spectrum of operations.’ With that overarching goal to frame us, the Army will undergo a major transformation...<sup>79</sup>

The transformation plan had three elements: the legacy force, objective force, and interim force (see Figure 4).<sup>80</sup> The division of the Army’s force structure and

---

<sup>78</sup> Vice Admiral Arthur K. Cebrowski and John J. Garstka, “Network-Centric Warfare: Its Origin and Future,” *Proceedings*, January (1998), <http://www.comw.org/rma/fulltext/overview.html>. Their article focused on Naval Operations but the concepts and terminology have become hallmarks of each Service’s transformation initiatives within the Department of Defense. It is not my intention to criticize Cebrowski’s vision of defense transformation; instead, the perverse application of his vision to the realm of irregular conflict. Cebrowski, who passed on November 12, 2005, should appropriately be remembered as an important visionary who helped launch insightful discussions about the future of warfare.

Cebrowski credited the term “network-centric warfare” to a speech given by the Chief of Naval Operations Admiral Jay Johnson, (U.S. Naval Institute Annapolis Seminar and 123d Annual Meeting, April 23, 1997).

<sup>79</sup> Dennis Steele, “The Army Magazine Hooah Guide to Army Transformation,” *Army Magazine*, 2001, [http://www.ausa.org/PDFdocs/Hooah\\_Guide\\_web.pdf](http://www.ausa.org/PDFdocs/Hooah_Guide_web.pdf). “Full-Spectrum” at this point referred to a spectrum of conflict, from low intensity threats to high intensity ones. This was later changed to refer to a spectrum of operations, including stability, offensive, and defensive actions.

<sup>80</sup> Steele, “Guide to Army Transformation.”

procurement was seen as a way of balancing the risks of an uncertain future strategic environment and the possibility that future technologies would fail to meet planners' expectations. Early planners envisioned two decades of development that would result in a futuristic objective force around 2020.

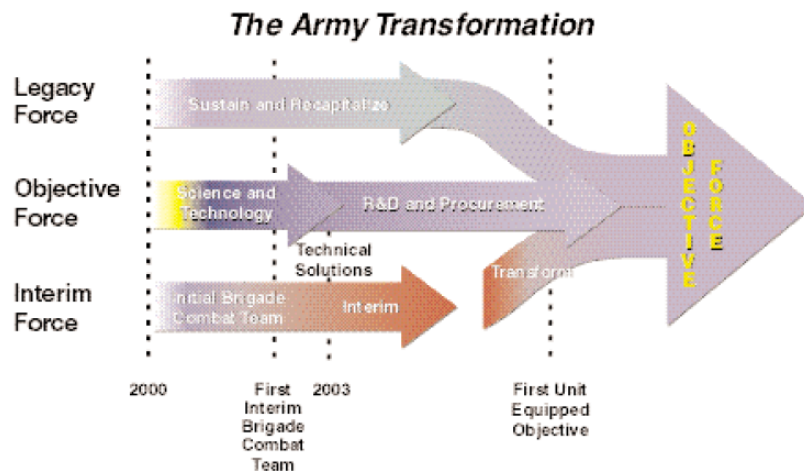

Figure 4. Army Transformation

The legacy force consisted of the Army's traditional heavy and mechanized infantry forces that would be sustained and continually modernized with new technology. Maintaining this force was seen as a hedge against the rise of potential near-peer competitors and would continue to be the nation's muscle in major combat operations requiring the mobility, survivability, and firepower of heavy armor. The legacy platforms could also serve as platforms for new vehicle mounted technologies.<sup>81</sup>

<sup>81</sup> To this day, FCS experiments have mostly been conducted on the M1 and M2 variant vehicles because of significant power and weight requirements. Already, discussions of a revolutionary homogeneous future force in 2020 are being replaced with an acknowledgement that legacy platforms will be part of the force structure for much longer. Furthermore, the creation of the Maneuver Warfare Center of Excellence at Fort Benning, GA, between 2006-2016 will combine the Army's infantry and armor training programs. While this provides for greater training synergies focused on traditional combined-arms maneuver battlefield, it may encourage education programs tailored to vehicular platforms, and lessen the infantry's needed focus on irregular threats and population-focused operations.

The interim force was the short-term focus of transformation, designed to consist of interim brigade combat teams (IBCTs)<sup>82</sup> that would fill the gap between light and heavy forces. They offered greater mobility, survivability, and firepower than light units, and could self-sustain for longer periods of time; but were designed to be light enough to be rapidly transported by aircraft. This force was advertised as being “full spectrum capable.”<sup>83</sup> While IBCT conversions were first initiated to fill strategic mobility and initial entry gaps identified during Operation Desert Shield, it also stood out as being particularly suited for small-scale contingencies, especially those in urban terrain.

The objective force was designed to be the gateway to the future. “The Objective Force will combine the deployability of light forces with the lethality, tactical mobility, and survivability of heavy forces.”<sup>84</sup> Replacing Force XXI,<sup>85</sup> the Future Combat System (FCS) family of vehicles, weapons, and sensors, was its focus. This system was advertised as being a fully networked Army of soldiers with enhanced capabilities, armed platforms that are lighter but stronger than today’s vehicles, unmanned ground and air vehicles, and a network of manned and unmanned sensors.

## 2. The Irregular Gap

The Army’s transformation was accelerated by the Secretary of Defense, Donald Rumsfeld, following the attacks of September 11th. He issued the Department of Defense’s *Transformation Planning Guidance* in April 2003 stating:

---

<sup>82</sup> Name later changed to Stryker Brigade Combat Teams (SBCTs) after the wheeled vehicle used as the units’ primary mobility platform.

<sup>83</sup> “Full spectrum capable” previously referred to the spectrum of conflict from low intensity to high intensity. The term has since been redefined to indicate a spectrum of operations that transitions between offense, defense, and stability operations capabilities. The term has been sufficiently watered down and all units are now considered “full spectrum capable.”

<sup>84</sup> Alan Vick, David Orletsky, Bruce Pirnie, Seth Jones, *The Stryker Brigade Combat Team, Rethinking Strategic Responsiveness and Assessing Deployment Options* (Santa Monica: RAND, 2002).

<sup>85</sup> Force XXI was the namesake for the Army’s software-based, information-age experimental force redesign. It was introduced as a concept in 1995 with the publication of *TRADOC Pamphlet 525-5, Force XXI Operations*. Ongoing tests throughout the late 1990s revealed both limitations and the potential for future technological applications to warfare. The program resulted in some equipment designs and software programs. Today, it has largely been replaced by the Future Combat Systems program. For a more detailed description, see <http://www.globalsecurity.org/military/agency/army/force-xxi.htm>.

Some believe that with the United States in the midst of a dangerous war on terrorism, now is not the time to transform our armed forces. I believe that the opposite is true. Now is precisely the time to make changes. The war on terrorism is a transformational event that cries out for us to rethink our activities, and to put that new thinking into action.<sup>86</sup>

The Army adjusted its short-term transformation plan to accelerate the conversion of divisions with their assorted brigade support units to modular brigades.<sup>87</sup> Joint interdependence between the military's services and expeditionary capabilities became the hallmarks of transformation. These concepts were implemented through a redesign of the division-centric mass Army to a brigade-centric maneuver force that was rapidly deployable, self-contained, and capable of achieving "decisive results." President Bush's 2003 statement provides an even greater summation of the new transformation concept:

...a future force that is defined less by size and more by mobility and swiftness, one that is easier to deploy and sustain, one that relies more heavily on stealth, precision weaponry and information technologies.<sup>88</sup>

While the United States was initiating a protracted war against guerrillas and terrorists, the Army was implementing a force structure designed and tested for the rapid defeat of conventional military forces.

Largely influenced by Cebrowski's popularized notions of warfare, Rumsfeld's guidance for the military's transformation was depicted as "fundamentally joint, network-centric, distributed forces capable of rapid decision superiority and massed effects across the battlespace."<sup>89</sup> It is ironic that Rumsfeld's written guidance was published immediately following the invasion of Iraq. While proclaiming the needs of the Global War on Terror, the guidance specifies, "We cannot afford to react to threats slowly or have large forces tied down for lengthy periods. Our strategy requires transformed forces

---

<sup>86</sup> Donald H. Rumsfeld's foreword to *Transformation Planning Guidance* (Washington D.C.: Department of Defense, April 2003), [http://www.oft.osd.mil/library\\_files/document\\_129\\_Transformation\\_Planning\\_Guidance\\_April\\_2003\\_1.pdf](http://www.oft.osd.mil/library_files/document_129_Transformation_Planning_Guidance_April_2003_1.pdf).

<sup>87</sup> From October 29, 2001 until January 31, 2005, the Department of Defense Office of Force Transformation was headed by (then retired), Arthur K. Cebrowski.

<sup>88</sup> George Bush as quoted by, DoD, *Transformation Planning Guidance*, 3.

<sup>89</sup> Donald Rumsfeld's foreword to, DoD, *Transformation Planning Guidance*, 1.

that can take action from a forward position and, rapidly reinforced from other areas, defeat adversaries swiftly and decisively...”<sup>90</sup> Irregular opponents and stabilization strategies were not part of the design criteria.

The roots of this proclamation, and its obvious shortcomings, can be seen in *Breaking the Phalanx*. Macgregor recognized the need for adaptable war fighting structures that must conduct a wide array of missions and discounted the “creation of new OOTW-specific [Operations Other Than War] military structures and training.”<sup>91</sup> Macgregor believed “recent trends of civil disturbance” to be of “peripheral strategic importance in order to secure the ideals and habits of democracy.” He recognized the lack of attention he gave “low-intensity conflict,” but stated that it would be unwise to shape the military to perform these actions. And while Macgregor claimed, “Army ground forces must be prepared to administer and control large populated areas of enemy territory until legitimate indigenous administration can be restored,” his chapter-long Iraq conflict scenario culminated with the “installation of a friendly government” one day after the arrival of U.S. forces in Baghdad.<sup>92</sup> To be fair, Macgregor acknowledged the troop-intensive nature of occupations, but the overall theme of *Breaking the Phalanx* is one of rapid combined arms maneuver against future conventional threats, using modern technological innovations.

Throughout the RMA and transformation discussions, an implicit assumption was that soldiers trained and units specifically organized for close conventional combat could

---

<sup>90</sup> DoD, *Transformation Planning Guidance*, 4.

<sup>91</sup> Macgregor, 169. McGregor suggests that the challenges posed by unconventional warfare and peacekeeping can be better managed through graduate level officer training instead of force design changes. Acknowledging improvements in education programs as paramount, in Chapter five this paper will argue that training time is finite. Greater specialization in the workforce will result in greater unit effectiveness during irregular warfare. This requires improvements to the Army’s education system *and* organizational change.

<sup>92</sup> Published in 1997, Macgregor demonstrated eerie foreshadowing using a fictitious conflict with Iraq in the future-year 2003. He described the future scenario to demonstrate notional capabilities of his force design proposal and technology-based strategy. While acknowledging irregular threats, Macgregor’s scenario entails large aerial dogfights, cruise missile strikes, MLRS bombardments, and a rapid invasion by a ground force that is closely mirrored six years later. During the imaginative scenario, Macgregor describes a ground force that can “deploy quickly and advance rapidly in great strength into the depths of the enemy’s territory...neutralizes enemy’s military capability...ensures a rapid collapse of his command system, and terminates the conflict.” Macgregor, 145.

easily conduct an array of other missions. Therefore, tests used to validate the new force designs were primarily focused on traditional combat and largely ignored “the other missions.” McMaster provided his perspective on one of the simulation scenarios as follows:

In constructive computer simulation exercises designed to “validate” the new design, near perfect intelligence permitted centralized targeting of large conventional forces such that long-range rocket artillery, Apache helicopters, and other fires compensated for the division’s reduction in combat power. The new division was “smaller” yet “more lethal” because the assumption of dominant knowledge gave the unit “situational understanding.”<sup>93</sup>

The scenarios were a throwback to the Gulf War. Irregular threats and the effects of urban terrain were primarily ignored while the merits of information technologies were largely inflated.

In addition to testing scenarios and strategists’ assumptions, a lack of emphasis on stability operations should not be surprising given its portrayal in the Army’s previous doctrinal literature. *FM 3-0, Operations*, is the Army’s flagship how-to-fight manual.<sup>94</sup> In its 2001 version, it embodied the lexicon of classic combined arms doctrine, the “close with and destroy” concept, that is insufficient and often times counter-productive to the intricacies of irregular conflict.

In stability operations, close combat dominance is the principal means Army forces use to influence adversary actions. In all cases, the ability of Army forces to engage in close combat, combined with their willingness to do so, is the decisive factor in defeating an enemy or controlling a situation.<sup>95</sup>

This statement is incredibly misleading. While the capacity for violent, small-unit, close combat is as necessary in irregular warfare as it is conventional combat

---

<sup>93</sup> McMaster, *Crack in the Foundation*, 30.

<sup>94</sup> Department of the Army, *FM 3-0, Operations* (Washington D.C.: Government Printing Office, June 2001). This manual is currently under revision. The updated version, *Full-Spectrum Operations*, places greater emphasis on stability operations than its predecessor.

<sup>95</sup> Task Force Modularity, *Army Comprehensive Guide to Modularity, Volume 1, Version 1.0* (Fort Monroe, VA: U.S. Army Training and Doctrine Command, October, 2004), 6-3, [http://www.forscom.army.mil/weathr/Army\\_Transformation/Mod\\_OO\\_v.\\_1.0.pdf](http://www.forscom.army.mil/weathr/Army_Transformation/Mod_OO_v._1.0.pdf).

operations, the Army has painfully realized that it is rarely sufficient to achieve sustainable battlefield success. In response to the problems facing troops in Afghanistan and Iraq, the Army published a manual on counterinsurgency in December of 2006.<sup>96</sup> Instead of “defeating the enemy,” protecting the populace becomes decisive. Fostering effective indigenous governance, creating political solutions, low-level intelligence gathering, law enforcement, and facilitating economic growth becomes just as important as “close combat dominance.” Former brigade commander, Colonel Mike Shields notes, “without some kind of economic development or reconstruction, security alone won’t fit the bill.”<sup>97</sup>

The Army’s initial handbook on transformation’s structural changes was *The Army Comprehensive Guide to Modularity, (Guide to Modularity)*.<sup>98</sup> It is filled with diametrically opposing concepts of threat, strategy, and force structure as it defends the notion that the BCT provides an all-purpose structural and capabilities framework for the Army. Appropriately, the Army’s close combat threat is portrayed as being increasingly unconventional in nature, often operating in restrictive terrain (such as urban areas), and frequently adopting guerrilla and terrorist tactics. An insurgent threat will “depend upon the acquiescence, if not active support, of the indigenous population.” Yet, within the next few pages of the guide, air power, attrition of the enemy, and exploiting maneuver are but a few of the descriptions of the BCT’s close combat capabilities. These contradictions support Hammes’ argument that DoD initiatives such as those posed in the *Transformation Planning Guidance* and *Joint Vision 2020* are focused primarily on high-technology conventional war—seemingly new tools for the same job, yet marketed under

---

<sup>96</sup> Department of the Army, *FM 3-24, Counterinsurgency* (Washington D.C.: Government Printing Office, December 2006).

<sup>97</sup> Colonel Mike Shields, former commander, 172<sup>nd</sup> Stryker Brigade Combat Team (presentation at the Infantry Warfighting Conference, September 19, 2007, Ft. Benning, GA).

<sup>98</sup> Army, *Guide to Modularity*. This manual contains descriptions and illustrative depictions of the revised tables of organization and equipment from division-level to the company and platoon. Filled with wire diagrams and block charts, this document is intended to both clarify and justify the Army’s organizational changes in accordance with current transformational initiatives. It has since been replaced by Department of the Army, *FM 3-90.6, The Brigade Combat Team* (Washington D.C.: Government Printing Office, August 4, 2006).

the “rubric of transformation.”<sup>99</sup> While the DoD has made adjustments to its post-9/11 training strategies and doctrine, its basic organizational structure at the tactical level remains wed to antiquated defense strategies. Today’s transformation is not wrong; it’s just not enough.

### 3. A New Direction?

While Shinseki used the 1999 AUSA conference to initiate the Army’s transformation to a more expeditionary force, Secretary of Defense Robert M. Gates used the same venue on October 10, 2007 to budge the U.S. Army in a different direction than his predecessor.<sup>100</sup> Gates noted the military’s aversion to irregular conflicts following the Vietnam War, leaving the Army “unprepared to deal with the operations that followed in Somalia, Haiti, the Balkans and more recently, Afghanistan and Iraq—the consequences and costs of which we are still struggling with today.” He expects asymmetric warfare to “remain the mainstay of the contemporary battlefield for some time,” and although he didn’t advocate any specific plans, Gates challenged the Army not to treat Iraq and Afghanistan as anomalies. Instead, he emphasized that the Army must develop greater advising capabilities, language proficiencies, and hone its ability “to fight smaller forces of insurgents.” Additionally, he revived a term purposely abandoned by his predecessor—nation-building.

Army soldiers can expect to be tasked with reviving public services, rebuilding infrastructure and promoting good governance...all these so-called ‘nontraditional’ capabilities have moved into the mainstream of military thinking, planning and strategy, where they must stay.

A recent *Army Times* article further highlights the disconnect between the current operating environment and the force-mix available to meet its demands.<sup>101</sup>

---

<sup>99</sup> Hammes, *Sling and the Stone*, 225.

<sup>100</sup> For quotes and commentary from his presentation, see Julian E. Barnes and Peter Spiegel, “Rethinking the U.S. Army,” *Los Angeles Times*, October 10, 2007; Barnes, “Gates Urges Funds for a Smarter Army,” *Los Angeles Times*, October 11, 2007; Lolita C. Baldor, “Gates Envisions an Army Remade to Fight Future Wars,” *Seattle Post-Intelligencer*, October 11, 2007; and David S. Cloud, “Gates Says Military Faces More Unconventional Wars,” *New York Times*, October 11, 2007.

<sup>101</sup> Michelle Tan, “Deciding Who Goes, Where and When,” *Army Times*, October 14, 2007.



Commander's in Iraq and Afghanistan are increasingly requesting "designer units," force requests tailored to their current environments. According to Colonel Edge Gibbons, Chief of FORCOM's plans division:

As [the] theater has matured, the additional capabilities required often don't match existing Army inventory for certain niche capabilities that are required based on the operating environment...It decreases readiness of the Army because it's breaking units. For every designer unit we make, that's one or more units that we break to meet that requirement.

While the Army touts the flexibility of the current modular design, it is ill-suited to meet the demands of its current theaters. Instead of adjusting the Army's force structure to embrace mission tailoring and modularity as advertised, FORSCOM is discouraging the use of "designer units." Instead of changing the force mixtures available, the Army seems to be telling commanders in the field, "make do with what you have." Regardless of the scale of today's conflict, the Army should better tailor its force design to the current operating environment, assuming (as Secretary Gates does) that this will be more indicative of future conflict than previous assumptions foretold.

Thus far, early planning assumptions and operational imperatives of the Army's "transformation" have been examined. The next section will be a descriptive overview of the Army's modular brigade concept.

### **C. BRIGADE MODULARITY**

The basic premise of the Army's recent force structure change was to disassemble certain corps and division support brigade structures to create autonomous and rapidly deployable brigade-centric ground forces. Previously a combined arms brigade combat team was not structured with organic support capabilities, relying instead on attachments from divisional units. Instead of the division, the brigade has become the basic building block of the Army. This allows faster deployment, more rotational depth, and better task force tailoring, while supposedly reducing the number of redundant support commands who have no war-time responsibilities.<sup>102</sup> As part of the ongoing restructuring plan and

---

<sup>102</sup> Walker, "Army Force Structure and Implementation of Directive 3000.05."

pending an active component/reserve component initiative, the Army intends to convert over 100,000 individual specialty positions from “low demand” skill sets to “high demand” professions.<sup>103</sup>

In May of 2007, the National Defense University (located at Fort McNair, Washington D.C). held a conference on “Force Structure for Stability Operations and Interagency Integration.” The Army’s Deputy Director for Strategy, Plans, and Policy, gave a presentation titled, “Army Force Structure and Implementation of Directive 3000.05.”<sup>104</sup> According to the presentation, the modularity plan centered on the brigade combat team design, augmented by functional or multi-functional modular brigades “allows units to be designed and adapted in ‘real time’ to execute stability operations in any environment under any condition.” The presentation notes it as the “most significant Army restructuring in the last 50 years.” In particular, the current modularity plan was advertised as follows:<sup>105</sup>

- Modular brigades can “plug and play” with different corps and division HQs.
- Units are decentralized, leader-enabled command and control.
- The brigade combat team (BCT) is organized to include stability operations capabilities.

---

<sup>103</sup> Walker, “Army Force Structure and Implementation of Directive 3000.05,” slide 26. This long-term plan has soldiers being “retrained and reallocated” from field artillery, air defense, engineers, armor, and certain logistics units to military police, transportation, civil affairs, special operations, biological detection, and military intelligence units. According to Boozell, (interview, October 17, 2007) most of these conversions are occurring through attrition in over-strength specialties and placing new recruits into under-strength specialties. Most of these specialists are grouped together in functional and multi-functional brigades, separate from the brigade combat teams.

<sup>104</sup> Restructuring was not the only intent of the Walker, “Army Force Structure and Implementation of Directive 3000.05.” The speaker discussed a number of issues relevant to the military’s DOTMLPF system’s approach. Other messages included: Doctrine- A host of new doctrine has emerged since 9/11 to address changes in threat environment (conventional and unconventional), an operating environment that is increasingly joint, interagency, and multinational, and emerging tactics centered on “full-spectrum” operations. Training- Improvements have been made to the Army’s combat training centers that exercise “continuous, complex counterinsurgency operations,” stress the importance of civil affairs, and utilize ethnic role players. The speaker stressed the importance of cultural awareness, language capabilities, and highlighted recent initiatives to improve those dimensions of soldier training. Material- Numerous procurement initiatives related to combat operations in Iraq and Afghanistan were highlighted. Leadership- Leadership and education programs have been revitalized with increased instruction in COIN, stability operations and cultural studies. Additionally, the Army has expanded the availability of fellowships and graduate programs.

<sup>105</sup> Walker, “Army Force Structure and Implementation of Directive 3000.05,” slide 12.

- Either a functional or multi-functional modular brigade will augment the BCT to enhance capabilities.

The brigade combat teams are the principal tactical units of the modular Army. They are designed specifically for major combat operations: “Their core mission is to close with the enemy by means of fire and maneuver to destroy or capture enemy forces, or to repel their attacks by fire, close combat, and counterattack.”<sup>106</sup> While optimized for major, conventional combat, they are reportedly “capable” of conducting stability operations, and with augmentation can be tailored for a wide variety of missions. Although the BCTs are generally designed to “operate in any OE [operational environment] and against any threats, each BCT has unique characteristics.”<sup>107</sup> They are divided into the heavy (HBCTs), Stryker (SBCTs), and infantry (IBCTs) brigade combat teams.<sup>108</sup> Additionally, a mix of support brigades can be added to Army divisions or used to augment BCTs. The modular support brigades available to most division-level task forces are the following: aviation, reconnaissance, surveillance and target acquisition (RSTA), maneuver enhancement (ME), fires, and sustainment.<sup>109</sup> The active-duty modular force as currently planned includes 48 brigade combat teams, 39 multi-functional support brigades, and 41 functional support brigades (see Figure 5).<sup>110</sup>

---

<sup>106</sup> Army, *FM 3-90.6*, 2-1. The manual explicitly states, “BCTs are optimized for MCO (major combat [read conventional] operations).”

<sup>107</sup> Army, *FM 3-90.6*, A-1.

<sup>108</sup> Army, *FM 3-90.6*, viii. The interim naming conventions were designed to prevent force designers from leaning on past references as the Army was trying to reduce top-level layers of command (see DoD, *Transformation Roadmap*, 3-5). Since publication of the *Transformation Roadmap*, the Army has replaced its abstract naming conventions of Unit of Action (UA), Unit of Employment (UEX), and Unit of Employment (UEY) with the legacy naming conventions of Brigade Combat Team and Division. All levels of command from Company to Corps present in the prior system are maintained in the new one. Also, Stryker Brigades, named after the vehicular platform for which it was designed, have gone through a series of naming conventions to include “interim,” “initial,” and “medium” brigades.

<sup>109</sup> Army, *Guide to Modularity*, Chapter 1.

<sup>110</sup> The exact number and allocation of Brigade Combat Teams, Functional, and Support Brigades are frequently being adjusted based on resource allocations, policy guidance, and threat scenarios. The 2006 QDR, BG Twomey’s “Cost of Modern War” presentation, Walker’s NDU Brief, and General Campbell’s Infantry Warfighting Conference presentation had varying numbers. The numbers used here are based on Walker, “Army Force Structure and Implementation of Directive 3000.05.”

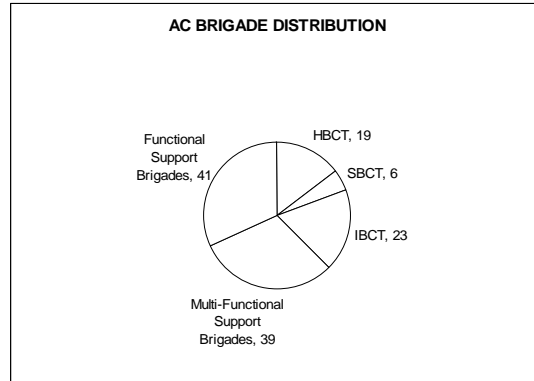

Figure 5. Active Component Brigade Allocation

### 1. Heavy Brigade Combat Teams

The HBCT is tank-centric. As such, it is considered the Army’s premier fighting unit to conduct major combat operations. It places a premium on mobile protected firepower balanced with dismounted infantry. The HBCT is particularly suited for the following operational environments:<sup>111</sup>

- open or mixed terrain that can support the size and weight of armored vehicles
- offensive and defensive operations against enemy conventional ground forces

Some of the disadvantages of the HBCT include the following:

- restricted mobility in mountainous, forested, and dense or poorly developed urban terrain
- a large geographical footprint required for logistics basing and vehicle positioning
- vulnerability to mines and advanced antitank weapons
- high usage rate of consumable supplies such as fuel, ammunition, and maintenance repair parts<sup>112</sup>
- high costs associated with transporting, operating, and maintaining tanks and Bradley fighting vehicles

<sup>111</sup> This is a compilation from, Army, *Guide to Modularity* and Army, *FM 3-90.6*, A-7, A-9.

<sup>112</sup> Army, *FM 3-90.6*, A-4 provides emphasis—“do not underestimate its (logistics) requirements.”

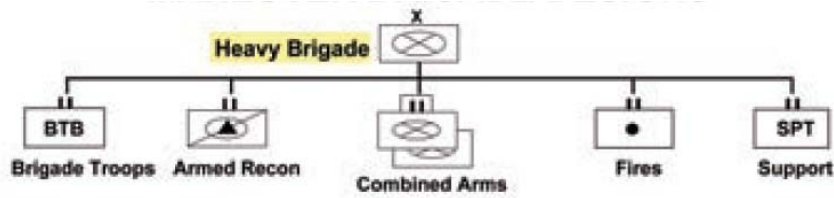

Figure 6. Heavy Brigade Combat Team (HBCT)

The HBCT is composed of approximately 3,800 soldiers organized into two combined maneuver battalions, a reconnaissance squadron, a fires battalion, a brigade special troops battalion (BSTB), and a brigade support battalion (BSB). Each combined maneuver battalion is organized with combined arms (infantry, armor, engineer, artillery support etc). at the battalion level. The BSTB includes an assortment of headquarters staff, a military police platoon, a signal company, and a 118-man military intelligence company.<sup>113</sup>

The heavy brigades are explicitly designated as a hedge for major combat operations until FCS/Objective Force technology has matured. While there are critical applications for tanks in certain aspects of IW, armor is generally not the ideal force choice for population-focused operations. Although there are specific applications for heavy forces that will be explored later, the HBCT will not be the focus of this analysis. Instead, the Stryker and Infantry BCTs will provide the comparative baseline for further structural changes necessary to serve the Army’s irregular warfare requirements.

## 2. Stryker Brigade Combat Teams

The Stryker brigades were designed to fill the strategic gap that existed between light and heavy forces. This gap was described earlier when the 82<sup>nd</sup> Airborne drew a line in the sands of Saudi Arabia during Operation Desert Shield. Light forces offered rapid, strategic mobility but didn’t have tactical mobility or reliable staying power once deployed. Heavy forces had the protection and firepower to combat conventional enemies, but took too long to deploy. On October 12, 1999, General Eric Shinseki

<sup>113</sup> Army, *Guide to Modularity*, Chapter 8. These numbers are according to the published 2004 MTOE. Although subtle changes are ongoing, they provide an overview.

initiated the transformation process to field medium-weight brigades that could deploy worldwide within four days.<sup>114</sup> The Stryker vehicle is the identifying mobility platform for this motorized unit. The Stryker is a wheeled, medium-weight, armored vehicle that can be configured as a troop transport or to a more specialized function. Beyond rapid strategic deployment, the SBCT's advertise themselves as the optimal full-spectrum combat force possessing robust intelligence, combined arms battalions, and a unique balance between lethality, mobility, and survivability. The SBCT is also the transitional force design that is supposed to provide the experimental foundation of the Army's objective force as legacy forces are dissolved and FCS is brought (quite literally) online.

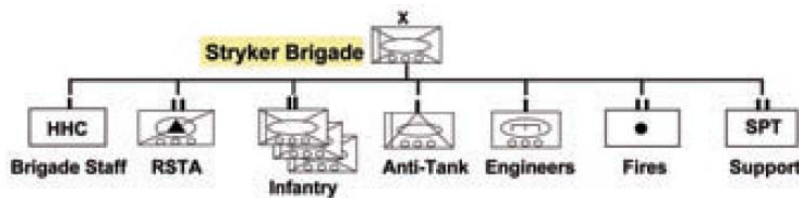

Figure 7. Stryker Brigade Combat Team (SBCT)

The SBCT has approximately 4,000 soldiers in its “ready to fight” configured package. It contains three infantry battalions, a reconnaissance, surveillance, and target acquisition (RSTA) squadron, a field artillery battalion, an anti-tank company, engineer company, signal company, military intelligence company, a brigade support battalion, a brigade headquarters, and the headquarters company. The Army designed the SBCT for early entry operations and “small scale contingencies.”<sup>115</sup> Some of the SBCT's operational advantages include the following:<sup>116</sup>

<sup>114</sup> General Shinseki's keynote speech entitled, “Army Vision,” at the 1999 Association of the United States Army (AUSA) Conference is largely heralded at the starting point for the Army's transformation. New “medium weight” brigades were only one aspect of transformation. Brigade modularity, unit-manning systems, and the objective force (now FCS) development are also major aspects of the concept. Concerning deployment timelines, see Vick, *The SBCT, Rethinking Strategic Responsiveness and Assessing Deployment Options*. This report negated the Army's 4-day deployment window, determining the deployment time actually ranged from 9-21 days based on predicted resources and capabilities. Deploying from forward bases and using combination of air and sea lift could reach most regions 5-9 days.

<sup>115</sup> Army, *FM 3-90.6*, A-9. As opposed to major combat operations against a conventional enemy, “small scale contingencies” are more synonymous with today's vernacular—irregular warfare. However, small indicates a limited scale of conflict. As discussed before, irregular warfare is not limited to “small” conflicts, or those “low” in intensity.

<sup>116</sup> This is a compilation from the *Guide to Modularity* and *FM 3-90.6*, A-7, A-9.

- operations in or near urban terrain
- combating conventional or unconventional enemies
- premium on infantry strength and motorized transport
- balanced between strategic, operational, and tactical mobility
- four maneuver battalions instead of the three in the HBCT and IBCT
- armor capabilities in the Mobile Gun System (MGS) platoons, organic to infantry battalions
- less logistics overhead than HBCT

The SBCT limitations are relative to the HBCT and IBCT include the following:

- It doesn't have the protection or firepower of the HBCT, but more so than the IBCT.
- It is easier to deploy than the HBCT, but requires more aircraft than an IBCT.

### **3. Infantry Brigade Combat Teams**

The infantry brigade combat teams are the manpower-intensive units within the Army's force structure. Limited in organic mobility, their primary method of movement is by foot, making the infantry ideally suited for population-focused interactions. Their small signature allows them to reside in close proximity to indigenous populations without undue burdens. Furthermore, they are the least technologically-dependent units, making them ready-made for advising and training technology-limited foreign Army and police units. The infantry BCTs operational capabilities include:

- dismounted infantry operations in restrictive terrain such as mountains, jungles, forests, and dense urban areas
- premium on strategic mobility, and conducting air assault, air mobile, and airborne operations
- small-unit operations

Their limitations include:

- a severe lack of motorized armored protection and heavy firepower
- limited ground mobility provided by supporting transportation units
- only two maneuver battalions, limiting the IBCT's options "for retaining capabilities for a pursuit, exploitation, or reserve force"

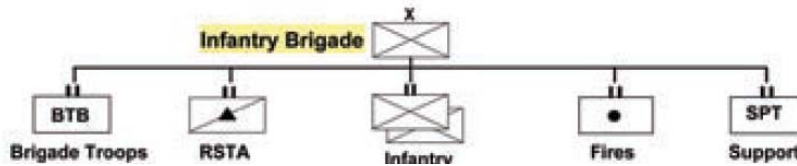

Figure 8. Infantry Brigade Combat Team (IBCT)

The IBCT is composed of approximately 3,400 soldiers organized into two infantry battalions, a reconnaissance squadron, a fires battalion, a brigade special troops battalion (BSTB), and a brigade support battalion (BSB). The BSTB and BSB are slightly smaller, but organized similarly to their respective battalions as described in the HBCT.

#### 4. Multi-Functional Support Brigades

According to the Army, functional and multi-functional support brigades can augment division and corps headquarters, or integrate necessary specialists into combat brigades so the brigades may be specifically tailored to a given mission. The multi-functional brigades were designed to support various levels of command. They are organized according to specific capabilities such as providing aviation support, indirect fires, or additional logistics support. The planned allocation of multi-functional support brigades and types are listed in Figure 9.<sup>117</sup> One of the primary advantages of the functional brigades is to maintain technical proficiency within a cohesive unit capable of training, supporting, and operating systems that require a high-level of specialization. The combat aviation brigades and fires brigades offer functional capabilities that are reliant on a high degree of technical training. The capabilities are designed to offer the division and higher headquarters operational flexibility, and when necessary, provide assets in direct support to the BCTs. The battlefield surveillance brigade (BFSB)<sup>118</sup> is

<sup>117</sup> As stated earlier, the numbers used are from Walker, “Army Force Structure and Implementation of Directive 3000.05.”

<sup>118</sup> Also known as the Reconnaissance Surveillance Target Acquisition (RSTA) Brigade.



designed to conduct reconnaissance, surveillance, target acquisition and intelligence operations at the operational level to help the Joint Task Force commander position his combat power.

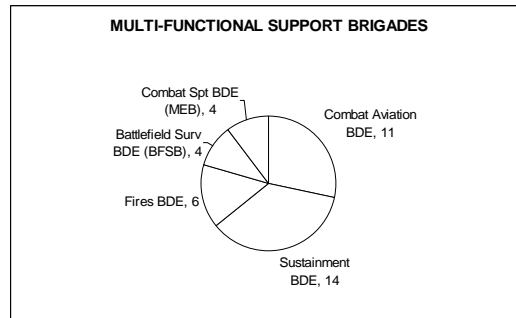

Figure 9. Multi-Functional Support Brigades Allocation

## 5. Functional Support Brigades

Similar to the aviation and artillery multi-functional support brigades, the functional support brigades are grouped by branch-specific single function capabilities. They are similar in design to the previous force structure's division support brigades. The planned type and numbers of functional support brigades are listed in Figure 10. According to a recent briefing, "As a general rule, functional support brigades are assigned, attached, or OPCON to a theatre-level command or Army HQ and support theater-wide operational requirements."<sup>119</sup> However, as a secondary purpose, these brigades are available to "provide reinforcing tactical capabilities to the brigade combat teams and the modular support brigades."<sup>120</sup>

---

<sup>119</sup> Walker, (NDU take-home CD), slide 81.

<sup>120</sup> Walker, (NDU take-home CD), slide 81.

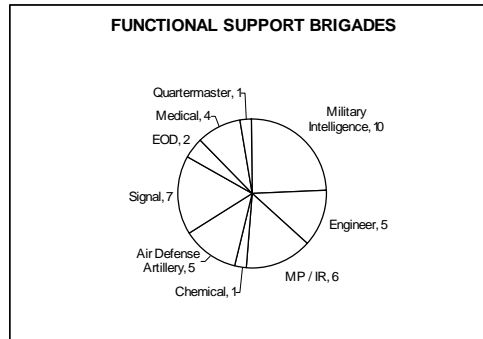

Figure 10. Functional Support Brigade Allocation

The functional support brigades provide single-function homogeneous units that are able to train, assess, and develop doctrine for their specialty areas that often require high degrees of professional training. Multi-tiered command chains allow leader development within functional units. In some cases, they may be employed as a cohesive unit when a theatre commander wants to maintain functional, not geographical task differentiation within a campaign. Otherwise, subordinate functional units (battalions or companies) may be resourced to brigade combat teams or a maneuver enhancement brigade where functional capabilities can be integrated below the theatre level. The engineer, military police, explosive ordinance disposal (EOD), and medical specialties have been in particularly high demand and limited availability during ongoing conflicts in Iraq and Afghanistan.

#### **D. BELOW THE BRIGADE**

So far this description has provided an operational overview of the modular brigade concept. To understand capabilities below the brigade level, this chapter will now turn to three functional areas especially relevant to irregular warfare: intelligence; security; and civil-military operations such as information operations (to include public affairs and psychological operations), civil affairs, and civil engineering. These three areas provide the guiding framework for the remainder of this study's analysis and recommendations.

# 1. Intelligence

## a. Brigade Intelligence

Brigades are now staffed with a sizeable intelligence staff and an intelligence company within the brigade troops battalion (BTB). As part of the current force design, most divisional military intelligence (MI) battalions were inactivated. The direct support MI companies that had a habitual relationship with each brigade, simply became permanently assigned to the BCT. The analysis and control element (ACE) within the division MI battalion was absorbed by the division's G2 staff. New to the brigade-level MI company was enhanced top-secret communications capabilities,<sup>121</sup> UAVs, HUMINT specialists, and signals intelligence systems. Army-wide MI assets are planned to increase by almost 9,000 more soldiers and collection systems to include positions earmarked for over 3,000 HUMINT, 2,000 all-source, 1600 UAV, and 800 SIGINT specialists,<sup>122</sup> although the implementation details are vague.

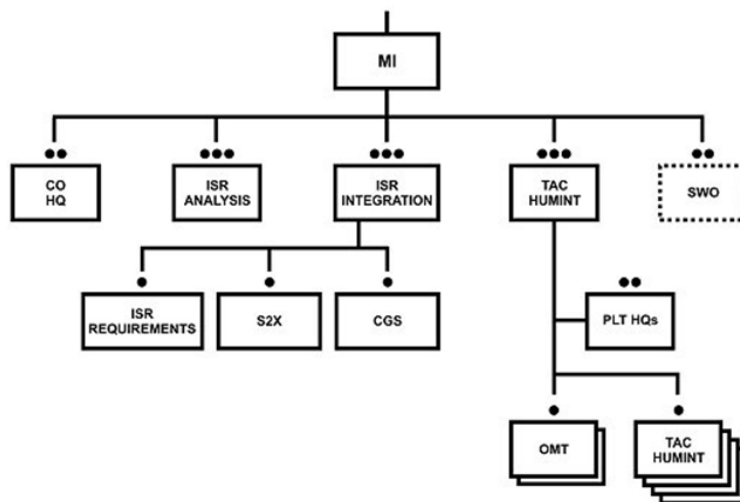

Figure 11. SBCT Military Intelligence Company

<sup>121</sup> Capabilities allow brigade-level intelligence staffs to access national intelligence databases from DIA, CIA, and other agencies. Previously this capability was reserved for the division level.

<sup>122</sup> Stephen K. Iwicki, "CSA's Focus Area 16: Actionable Intelligence...one year later," *Military Intelligence Professional Bulletin*, October-December (2004), [http://findarticles.com/p/articles/mi\\_m0IBS/is\\_4\\_30/ai\\_n13822278/print](http://findarticles.com/p/articles/mi_m0IBS/is_4_30/ai_n13822278/print).

The newly designed MI company consists of approximately 120 personnel.<sup>123</sup> The IBCT MI company consists of a small headquarters section, a tactical UAV platoon, an analysis and integration platoon, and a tactical HUMINT platoon. Typically, it has three dedicated two-man HUMINT teams (out of a brigade of approximately 3,500 soldiers), and two prophet SIGINT collection systems organic to its task organization. The SBCT brigade's MI company is similar to others already described except its number of HUMINT teams is more robust and the UAV platoon is embedded with the RSTA squadron (see Figure 11 above).<sup>124</sup> It maintains an ISR integration platoon, ISR analysis platoon, and a tactical HUMINT platoon. HUMINT and signal intelligence (SIGINT) teams are sometimes assigned under tactical control to subordinate battalions, usually for a limited time and purpose.

***b. Reconnaissance Squadrons***

As part of the Army's modular design, the infantry brigades lost a maneuver battalion, gaining a reconnaissance squadron with half the manpower in its place. On a traditional battlefield, the reconnaissance squadrons are designed to be the "eyes and ears" of the brigade commander, collecting intelligence so he can conduct effective maneuver by his infantry or armor battalions. The IBCT reconnaissance squadron consists of 304 soldiers organized into a headquarters troop and three recon troops of approximately 70 soldiers (as compared to a 600 to 700 soldier maneuver battalion). Two of the troops are motorized using armored HMMWVs, while one is a dismounted recon troop. The reconnaissance squadrons are mostly manned by enlisted scout specialists (19D) in lieu of infantrymen (11B) and their officers are predominantly armor officers (see Figure 12).<sup>125</sup>

---

<sup>123</sup> Army, *Guide to Modularity*, 7-8, 7-9.

<sup>124</sup> Army, *FM 3-21.31*, 18.

<sup>125</sup> Army, *Guide to Modularity*, D-7.

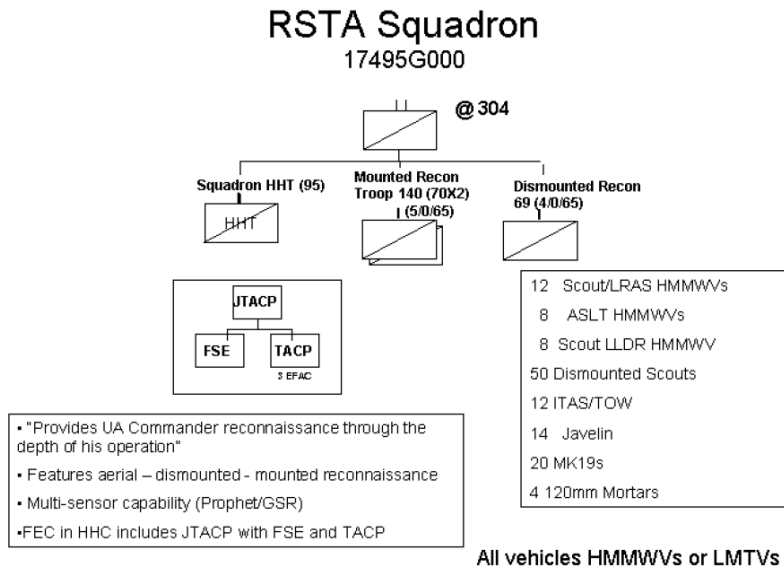

Figure 12. Infantry BCT Reconnaissance Squadron

The SBCT's RSTA squadron<sup>126</sup> is slightly larger than its lighter counterpart. It consists of three Stryker-mounted reconnaissance troops,<sup>127</sup> a headquarters company, and a surveillance troop consisting of a headquarters sections, a UAV platoon, a multi-sensor platoon, an MI integration platoon, and a chemical/decontamination platoon (see Figure 13).<sup>128</sup>

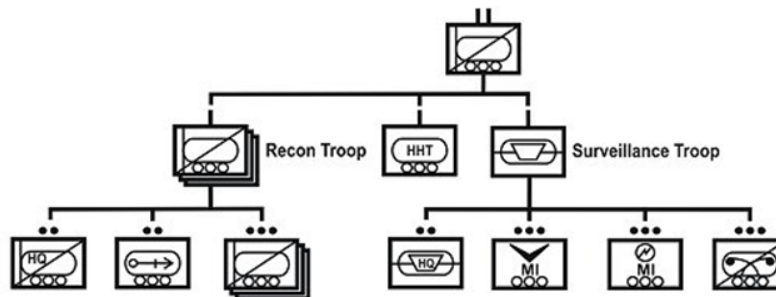

Figure 13. Stryker BCT Reconnaissance Squadron

<sup>126</sup> A squadron is commanded by a Lieutenant Colonel and represents the same command level as a battalion. Its naming difference is largely tied to historical lineage.

<sup>127</sup> A troop is commanded by a Captain and represents the same command level as a company.

<sup>128</sup> Department of the Army, *3-21.31, Stryker Brigade Combat Team* (Washington D.C.: Government Printing Office, 2003), figure 1-6.

*c. Battalion-level Intelligence*

A battalion of approximately 600 to 700 soldiers only has seven to eight dedicated intelligence personnel assigned (see Figure 14). This section is responsible for gathering the information collected by the companies, analyzing it, and reporting it to the brigade. Tracking current operations, preparing intelligence reports, directing subordinate collection efforts, conducting pattern analysis, developing and updating extensive social network diagrams, screening detainee, questioning informants, and conducting counter-intelligence operations provide the section more work than it can typically accomplish. There are no trained intelligence specialists below the battalion level although most units operating today have assembled out-of-hide, informal information processing and analysis teams.

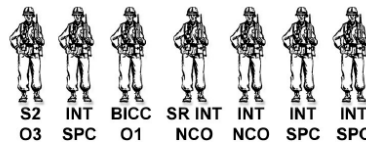

Figure 14. Battalion Intelligence Section

**2. Security and Mobility**

Security is the cornerstone for all other aspects of stabilization operations and counterinsurgency. Therefore, the ability of military units to secure terrain, capture and kill enemies, and guard populations is still the dominate activity for military units operating in hostile environments. The Army’s ability to distribute firepower and move to a position of advantage over conventional enemies is called maneuver. Tanks, Stryker vehicles, and foot soldiers are all designed to dominate in certain environmental and threat conditions as described earlier. Irregular warfare is no different. The type of soldiers and vehicles used to accomplish this purpose must be carefully analyzed.

*a. Light Infantry*

The legacy infantry brigade and the new infantry brigade combat team design changed from three infantry battalions to two infantry battalions and a reconnaissance squadron. The infantry battalions are relatively unchanged from their

previous design. Most infantry battalions consist of approximately 660 soldiers divided into three 141-man infantry companies of three rifle platoons each, and a 71-man motorized weapons company (see Figure 15). They are a legacy design, using HMMWVs equipped with anti-tank guided missile systems. The brigade support battalion's forward support companies consist of transportation platoons with wheeled transport vehicles able to truck two rifle companies of infantryman as needed.<sup>129</sup>

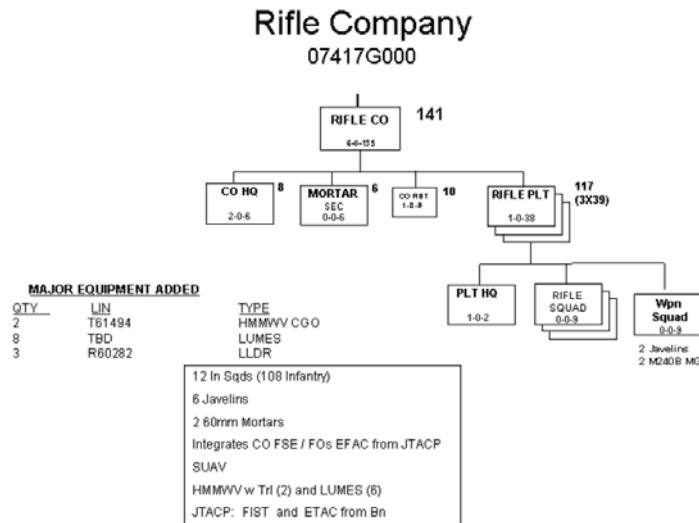

Figure 15. Infantry Rifle Company<sup>130</sup>

Some of the infantry brigade combat teams have modified task organizations, specifically designed for forced-entry operations. For example, the four brigade combat teams of the 82<sup>nd</sup> Airborne Division (and others) are designated for parachute operations. The four brigades of the 101<sup>st</sup> Airborne (Air Assault) are trained and organized for helicopter operations.

<sup>129</sup> Known as Light Medium Tactical Vehicles (LMTVs) or their earlier models, the “5-ton” and “2½-ton” trucks. They were designed for rear area troop and supply transport. Recent operations in Iraq and Afghanistan have displayed the vulnerability of these vehicles. In combat zones, they have been largely replaced with variants that have cab and side armor, but the troop carrying compartment is still uncovered. Soldiers are extremely vulnerable during transport. For example, seven soldiers from the 82<sup>nd</sup> Airborne were killed on September 10, 2007 when their LMTV overturned after a wheel blew. New vehicles are being tested and the MRAP (to be explained later) is finally being fielded in increased numbers.

<sup>130</sup> Army, *Guide to Modularity*, D-x.

***b. Stryker***

The Stryker infantry battalions consist of three rifle companies with three rifle platoons each. Each company also has a mobile gun system platoon (MGS),<sup>131</sup> a section of 60mm and 120mm mortars, and a sniper team. Within the rifle platoons, each squad has a wheeled, medium-armored infantry carrier available with mounted crew-served weapon. Additionally, the battalion has a mobile gun system platoon with firepower similar to tanks, but it is wheeled and less protected.

The Stryker RSTA squadron is larger than the light version with three troops of vehicle-mounted recon companies, an organic surveillance and sensor troop, and three chemical reconnaissance vehicles. The SBCT also has an anti-tank company that provides stand-off against enemy armor with three platoons of three Stryker anti-tank guided missile (ATGM) vehicles.

***c. Military Police***

The new BCTs were designed with a military police (MP) platoon of approximately 25 soldiers (out of the brigade's approximate 3,500). This platoon serves many roles, but as chapter five will show, its exact function has been a source of frequent disagreement. The MPs perform numerous duties to include:

- maneuver and mobility support consisting of checkpoints and traffic control for large-scale troop movements
- area security for the brigade headquarters
- law enforcement operations internal to the brigade
- internment resettlement and detainee operations
- police intelligence operations

Additionally, the brigade has a provost marshal (PM) assigned for planning and coordinating military police operations.

---

<sup>131</sup> An 8-wheeled armored fighting vehicle with a 105mm tank gun. It is not intended to conduct tank on tank warfare, but easily provides the firepower of a tank, without the infrastructure damage in an urban environment if needed.



### 3. Civil-Military Operations

Brigade headquarters are designed to allow flexible staff organizations tailored to the BCT commander's leadership style and the unit's mission. Typically, the BCT staff organizes into six functional and integrating cells. They are as follows: operations; sustainment; command, control, communications, and computers (C4); intelligence; information operations; and civil-military operations (see Figure 16).<sup>132</sup> The latter two functional areas are specific to irregular environments. Battalion and company-level maneuver units do not have any dedicated special planners who specialize in civil-military operations.

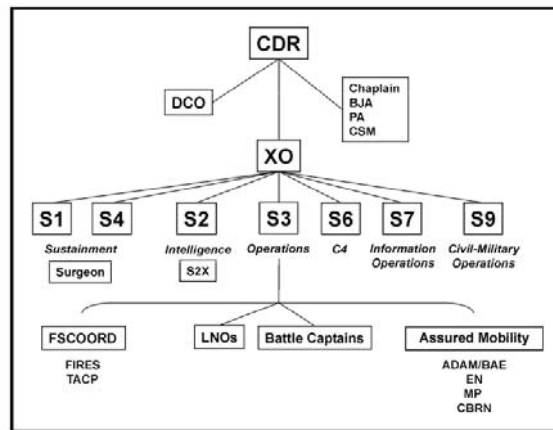

Figure 16. Brigade Staff

#### a. Information Operations

The S-7 is the brigade's coordinating staff officer to ensure information operations are integrated into the planning process. He works with other principal staff members to plan deception, psychological operations, and disseminate information to the local populace. Most brigades rely on ad hoc cells to fuse information operations themes and plans, or utilize the field artillery commanders as "effects coordinators," who are tasked with this duty.

<sup>132</sup> Army, *FM 3-90.6*, 2-10, 2-11.

*b. Civil Affairs*

The S-9 is the only civil affairs officer organic to the brigade. He is responsible for advising the brigade commander and operations officer on the relationship between the brigade and the civilian population. Additionally, the S-9 integrates attached civil affairs units into the brigade and assists them in the establishment of civil-military operations center(s).

Currently, the only active duty civil affairs units reside in Special Operations Command. The civil affairs community has proposed to increase its size by adding a fourth company to each battalion, creating the manning positions for a standing civil military operations center (CMOC) in each company, and increasing the overall force by over 188 teams.<sup>133</sup> Each civil affairs (CA) company would be designed to support a maneuver brigade, with each CA team supporting a maneuver battalion (see Figure 17).<sup>134</sup> The standing CMOC would provide a “store-front” for community dialogue, interagency coordinations, and NGO collaboration. The CA teams would serve as staff proponents to the battalions assisting with civil population mapping, governance, and economic development.

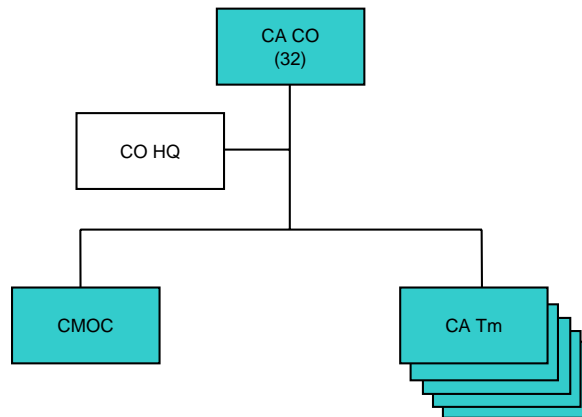

Figure 17. Proposed Expansion of CA Capacity to Support a BCT

<sup>133</sup> LTC Ritchie Moore and LTC Michael Warmack, “Civil Affairs Transformation,” (PowerPoint presentation dated March 24, 2005, email from Major Cameron Sellars, U.S. Army Civil Affairs).

<sup>134</sup> Moore and Warmack, (PowerPoint, March 24, 2005), slide 26.

Similarly, a CA battalion would support the division-level commander. It would provide the equivalent of provincial level stabilization and reconstruction support. Functional specialists would plan and coordinate specific areas of stabilization. Also, a conceptual civil information management cell would collate information regarding population demographics and infrastructure to establish an operational-level common operating picture.

*c. Engineers*

The engineer company assigned to the light and Stryker BCTs provide mobility support; they ensure the brigade's maneuver units are able to freely move throughout the battlefield. They are skilled at demolitions and obstacle reduction, performing "combat engineering tasks in support of close combat."<sup>135</sup> The brigade does not have dedicated assets capable of conducting construction or civil engineering assistance. Depending on the brigade's mission and availability of units, other types of elements could be attached to the brigade special troops battalion or individual maneuver battalions. The organic company consists of two combat engineer platoons and an equipment section. Each platoon is usually tasked to support one of the two infantry battalions. On some occasions the engineer platoon remains a cohesive unit within the battalion. Otherwise, the platoon headquarters is integrated into the battalion staff while the squads are tasked to provide direct support to the rifle companies. The engineer company in the Stryker BCT is composed of three mobility platoons and a mobility support platoon to account for its third infantry battalion.<sup>136</sup>

**E. ORGANIZATIONAL ADAPTATION?**

This chapter was an ambitious attempt to present the pivotal moments of the RMA discussion, and more specifically, the Army's recent "transformation" concepts. Even a cursory review highlights the obvious incongruence between "transformation's" initial assumptions and its current rhetoric. Difficulties in Iraq and Afghanistan have

---

<sup>135</sup> Army, *FM 3-90.6*, A-6.

<sup>136</sup> Army, *FM 3-90.6*, A-8.

shaken transformation discussions from their technologically-centric roots.<sup>137</sup> There is a growing realization within the Defense Department that “modernizing” our Army for irregular warfare in the twenty-first century must also include profound changes in the human work force. Still, an “irregular gap” persists. Optimized for strategic mobility and fluid, decisive, conventional combat, the organizational transformation launched in 2003 has remained unscathed despite changes in threat perceptions, profound changes in national security imperatives, and updated military doctrine. This chapter concluded with a descriptive overview of the Army’s current brigade-modularity force structure. This was an important, yet incremental step. Chapters V and VI will explain why further changes are necessary and offer recommendations for further designs. Secretary Gates recently encouraged Army planners to be innovative in exploring “how the Army should be organized.”<sup>138</sup> For now, the attention will be turned to alternative concepts from analysts who have done just that.

---

<sup>137</sup> General Campbell, FORSCOM Commander, recently lamented that, “modernization was inappropriately tied to FCS.” Comments, Infantry Warfighting Conference, September 18, 2007, Fort Benning, GA.

<sup>138</sup> Julian E. Barnes, “Gates Urges Funds For A Smarter Army,” *Los Angeles Times*, October 11, 2007.

#### IV. ALTERNATIVE MODELS FOR GROUND FORCE STRUCTURE

Over the past decade, the United States has made major investments in the combat efficiency of its forces. The return on investment has been evident in the dramatic improvement in war-fighting demonstrated from Desert Storm to the Kosovo air campaign to Operation Iraqi Freedom. There has been no comparable increase in the capacity of U.S. armed forces or of U.S. civilian agencies to conduct post-combat stabilization and reconstruction operations.<sup>139</sup>

When General Shinseki's transformation vision was initiated, an initial bifurcation emerged between those advocating for heavy investments in technology enhancements and those cautioning against it. In 2003, H.R. McMaster questioned ongoing defense transformation initiatives. He believed the underlying assumption of information dominance in future warfare created numerous vulnerabilities in the current force, stating: "The enthusiastic embrace, the assumption of near-certainty in future war is a dangerous fallacy."<sup>140</sup> He was primarily concerned with assumptions that traded information for combat power and sustainability, stressing that network-centric warfare should be pursued as a capability, not a strategy unto itself.<sup>141</sup> While McMaster cautioned defense planners against prioritizing information technologies over protection and firepower given the uncertainty and ambiguity of future conventional war,<sup>142</sup> other authors have begun nudging discussions about Army transformation in an entirely different direction.

---

<sup>139</sup> James Dobbins, John G. McGinn, Keith Crane, Seth G. Jones, Rollie Lal, Andrew Rathmell, Rachel Swanger, and Anga Timilsina, *America's Role In Nation-Building, From Germany to Iraq* (Santa Monica: RAND, 2003), xxvii.

<sup>140</sup> McMaster, *Crack in the Foundation*, 2.

<sup>141</sup> McMaster, *Crack in the Foundation*, 98.

<sup>142</sup> McMaster, *Crack in the Foundation*, 1.

## A. POST-2003 CRITICISM AND ALTERNATIVE DESIGNS

While the Army was beginning to implement its brigade modularity conversions, post-invasion difficulties in Afghanistan and Iraq were becoming all too apparent. As a result of September 11, 2001 and the military excursions that followed, a flurry of books, articles, and studies on grand strategy, counterinsurgency, stability operations, advising, and post-conflict stabilization have surfaced. Max Boot<sup>143</sup> made comments last year to the Council on Foreign Relations regarding his research on recent defense initiatives:

What I've seen over the course of the four years that I've been writing [this] book is sort of a transformation of the idea of defense transformation...when I started writing this book in 2002, defense transformation was a very techno-centric concept...using capital instead of labor...right now we've seen the limitations of those technologies...you still need people, and you need not only a lot of people, but you need the right kinds of people.<sup>144</sup>

Similarly, British counterinsurgency expert, Brigadier Nigel Aylwin-Fosters<sup>145</sup> finds *Military Transformation: A Strategic Approach*,<sup>146</sup> “uncompromisingly and ironically oriented towards warfighting in tone and content,” referring to a concentration towards high technology conventional capabilities. He recommends the military follow through on claims of “enhancing strategic and operational agility and responsiveness,” by investing more in the “human workforce.” While the Army contends that its current

---

<sup>143</sup> Max Boot is a Senior Fellow, National Security Studies, Council on Foreign Relations and the author of *Savage Wars of Peace* (New York: Basic Books, 2002), and *War Made New: Technology, Warfare, and the Course of History, 1500 to Today* (New York: Gotham Books, 2006).

<sup>144</sup> Max Boot's comments, “Military Strategies for Unconventional Warfare,” (Council on Foreign Relations, October 27, 2006), [http://www.cfr.org/publication/11834/military\\_strategies\\_for\\_unconventional\\_warfare\\_rush\\_transcript\\_federal\\_news\\_service.html](http://www.cfr.org/publication/11834/military_strategies_for_unconventional_warfare_rush_transcript_federal_news_service.html).

<sup>145</sup> Brigadier Nigel Aylwin-Fosters (U.K.), “Changing the Army for Counterinsurgency Operations,” *Military Review* November-December (2005): 2-15.

<sup>146</sup> Director, Force Transformation, Office of the Secretary of Defense, *Military Transformation, A Strategic Approach* (Washington D.C.: Department of Defense, Fall, 2003). [http://www.ofd.osd.mil/library/library\\_files/document\\_297\\_MT\\_StrategyDoc1.pdf](http://www.ofd.osd.mil/library/library_files/document_297_MT_StrategyDoc1.pdf).

general purpose, “full-spectrum” force accounts for the demands of stability operations, other analysts disagree and provide a wide array of policy and structural alternatives to consider.

## **B. A NEW BLUEPRINT?**

Thomas Barnett’s books seek to explain the growing interdependence of globalization, financial markets, and the military. In order to expand economic opportunities and social development to the underdeveloped areas of the world, Barnett advocates for the U.S. to adopt a preemptive dual-strategy of applying military pressure and development incentives in states along the Core-Gap divide.<sup>147</sup> Barnett recommends transforming the current military into two functions—“one to fight wars and one to wage peace.”<sup>148</sup> The “Leviathan” military would be focused on classic, conventional war fighting.<sup>149</sup> The “System Administrator” (SysAdmin) military would be the “rule-set enforcer for globalization’s advance” trained in the delicate tasks of post-conflict reconstruction, building indigenous security forces, bolstering weak governments, and setting the conditions for long-term infrastructure building, education, and local governance.<sup>150</sup> He identifies the SysAdmin force as a separate cabinet-level position on par with the State Department and Department of Defense.

---

<sup>147</sup> Thomas Barnett, *The Pentagon’s New Map* (New York: Penguin Group, 2004). Barnett divides the world’s nations into two definitive categories. The “Functioning Core” (Core) nations are modernized, have effective communications networks, and are connected through economic interdependence. The world’s “Non-Integrating Gap” (Gap) is not integrated into the rest of the world and as such is unable to reap the benefits of globalization. Barnett surmises that countries in the Gap will continue to be defined by poverty, inter-state and intra-state violence, and human rights calamities until they are connected to the Core countries. Connectedness will allow the free exchange of “mass media, ideas, capital, goods, technology, and people”.

<sup>148</sup> Barnett, *New Map*, 299.

<sup>149</sup> This military service would be poised to combat hostile militaries, remove governments that threaten world stability, and defend other Core countries. It would encompass most of the Air Force, Navy, heavy armor and artillery from the Army, and missile defense as described in Barnett’s follow on book, *Blueprint for Action* (New York: Berkley Publishing Group, 2005).

<sup>150</sup> Barnett, *New Map*, 299.

James Ellsworth supports the need for SSTR capabilities in the Department of Defense, but differs from Barnett's call for a separate cabinet-level agency.<sup>151</sup> Ellsworth notes that Barnett's arguments "overlook the fact that motion along the spectrum of conflict is neither unidirectional nor predictable," arguing that the ability to command and conduct SSTR operations in uncertain environments exists only with the DoD. Ellsworth, like many critics of the State Department believe civilian agency cultures are too far removed from contributing significant effort to operational duties in austere and oftentimes dangerous environments. Narrowing his focus to the DoD, Ellsworth outlines numerous problems that have frequently plagued the Army while conducting stability operations. After Ellsworth advances multiple force-structure options, he finally recommends a standing Joint Task Force or new joint command for stability operations, "USPEACECOM," that is heavy on "linguistic and cultural fluency," and built with an active-duty core but able to draw heavily from the reserves for desired "surge capacity." While Barnett calls for a separate agency and Ellsworth argues for a separate joint command, other military theorists have recommended changes internal to the Army.

### **C. A STABILIZATION FORCE?**

Hans Binnendijk and Stuart Johnson<sup>152</sup> provide assertions shared by many analysts that U.S. technological changes have led to a transformation of forces focused on "rapid decisive operations," requiring a subsequent transformation to be able to properly conduct stabilization and reconstruction operations. Binnendijk and Johnson see a transition of warfare from slow buildups and long wars with large numbers of troops and hence, large numbers of troops available for occupation during civilian led nation-building; to short wars with fast buildups, smaller numbers of troops and a gap with few forces available to conduct stabilization and reconstruction (S&R) after major conflict.

---

<sup>151</sup> James B. Ellsworth, "SysAdmin: Toward Barnett's Stabilization and Reconstruction Force," *The Land Warfare Papers* vol. 57 (2006), [http://www.ausa.org/PDFdocs/LWPapers/LWP\\_57.pdf](http://www.ausa.org/PDFdocs/LWPapers/LWP_57.pdf). He claims that the State Department's Office of the Coordinator for Reconstruction and Stabilization (S/CRS) is little more than an ambitious ideal, too far removed from its current culture of diplomacy and embassy duties to be effective.

<sup>152</sup> Hans Binnendijk and Stuart Johnson, eds., *Transforming for Stabilization and Reconstruction Operations* (Washington D.C.: National Defense University Press, 2004).



The authors propose modest force structure changes and the creation of two division-sized S&R forces drawn from active and reserve components and designed to be “flexible, modular, and scalable force multipliers.” The authors do not think the S&R forces should be embedded in combat units; however, “light combat units could be attached to the S&R force to provide it the capability to operate autonomously in a hostile environment.”

Binnendijk and Johnson make a compelling argument for military reform. Their ideas are well founded, yet the arbitrary number of two S&R divisions would offer marginal assistance to large-scale, sustained contingencies. In the absence of large contingencies, these forces would likely maintain an operational tempo exceptionally high as compared to conventional forces reserved for major combat. Binnendijk and Johnson are correct in identifying some of the skill sets that are required during stability operations such as civil affairs, military police, medics, and construction engineers. While these skills are essential to sustained irregular operations, they are predominately found in the reserves where mobilization may be constrained by political infighting and collective training might prove difficult. Furthermore, the DoD’s propensity to place these capabilities predominately in the reserves has not changed with the new force design.

Charles Barry advocates for a similar theatre-level stability operations Joint Task Force composed of military police, civil affairs, engineer, and medical battalions integrated into joint stability operations brigade-level task forces.<sup>153</sup> The theatre command would also be assisted by an array of combat brigades, and sustainment brigades (see Figure 18).

---

<sup>153</sup> Dr. Charles Barry, “Organizing Land Forces for Stability Operations,” (PowerPoint presentation, National Defense University, May 2007), slide 7, “Task Organized Model for Land Forces in Stability Operations: Theater SO JTF based on Combat Division.”

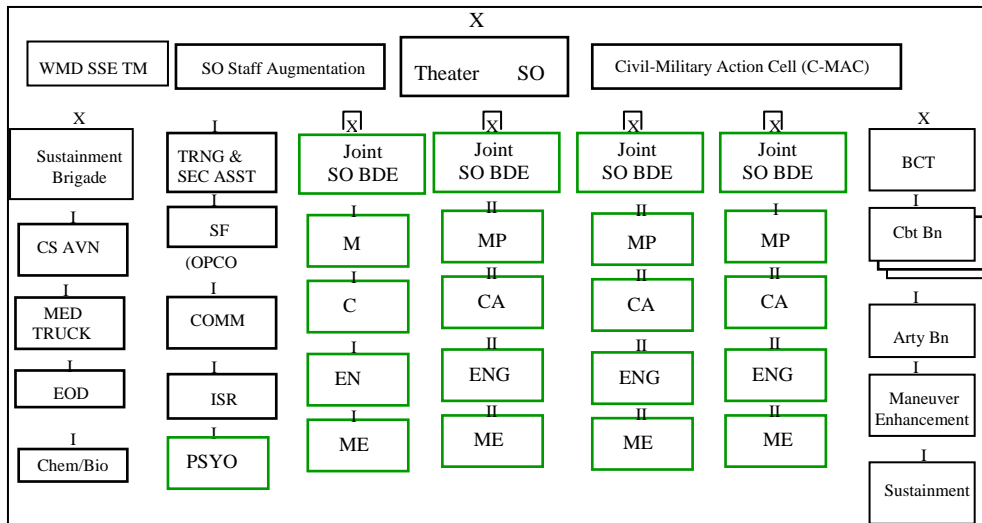

Figure 18. Stability Operations Joint Task Force

While he recognizes many of the capabilities integral to stability operations, units must be integrated to maintain security and conduct an assortment of operations such as intelligence analysis, civil affairs, and information operations at each level of command. Pooling these specialists together as suggested by Barry and others, creates a stove-piped command environment requiring top-level coordination and staffing. In the ambiguous environment of irregular warfare, senior-level decision making and coordination is extremely difficult, unresponsive, generalized, and time consuming.

Furthermore, battalions and brigade-level functional units create duplicate logistics and training structures that are costly, redundant, and oftentimes unnecessary during deployments. For example, civil affairs specialists should not have a primary task of driving a vehicle or operating its crew-served weapon. Civil affairs specialists should be educated on governance and economic models. They can be embedded with forces responsible for security in a given area. The civil affairs specialists should understand basic soldier-skills, but to focus collective training on independent patrols and convoy movements distracts from their core training tasks.

#### D. MORE MANEUVER ENHANCEMENT BRIGADES?

Colonel Brian Watson builds on Binnendijk and Johnson's S&R "gap theory."<sup>154</sup> Watson describes two significant transitions in post-conflict environments. The first is an initial turnover from "forward" brigade combat teams to stabilization forces in order to facilitate the former's "freedom of action and ability to maintain a relentless tempo of offensive action during decisive operations."<sup>155</sup> The second transition is to indigenous security forces and governance, State Department representatives, and civilian non-governmental organizations. As combat progresses, he envisions combat forces being relieved by stabilization-specific forces, assembled within the maneuver enhancement brigades.<sup>156</sup> According to Watson:

[The Army] must have a robust force pool comprised of modular and scalable combat support and service support units that can be tailored rapidly under multifunctional battalion and brigade headquarters and integrated into operations as coherent force packages. Modularity ensures the correct combinations can be achieved; scalability ensures the force can be right-sized for the specific mission."<sup>157</sup>

Watson recommends creating additional maneuver enhancement brigades that can provide command over stabilization efforts. Watson's assessment that greater stabilization skill capabilities are necessary is sound, but he incorrectly describes a linear battle-space where combat units can easily transition responsibilities to stabilization-

---

<sup>154</sup> Brian G. Watson, *Reshaping the Expeditionary Army to Win Decisively: The Case for Greater Stabilization Capacity in the Modular Force*, (Carlisle: Strategic Studies Institute, 2005).

<sup>155</sup> Watson, 15.

<sup>156</sup> Feickert, *U.S. Army's Modular Redesign: Issues for Congress*. The report outlines numerous areas of concern related to the Army's modularity program such as the proposed number of BCTs, the number of maneuver battalions contained within, lessons learned by the BCTs in Iraq and Afghanistan that could have implications on the design, related personnel and equipment shortfalls, and particular to this study, "Does the Army's current modular force design adequately address counterinsurgency and stabilization operations?" Towards the last question, the *CRS Report* provides an overview of *DoDD 3000.05* and uses the Strategic Studies Institute paper authored by Colonel Brian Watson in August 2005 as its mainstay evidence to question the Army's design. After summarizing COL Watson's arguments, the CRS report states, "the Army contends that the current modular forces construct [that BCTs are full spectrum forces, equally capable of performing traditional combat, counterinsurgency, and stability operations] is more than adequate to address the demands of stability operations, asserting that the modular force, as designed, has vastly improved communications infrastructure. (5-6)"

<sup>157</sup> Watson, 11.

specific forces. Guerrilla threats and insurgent movements will threaten the civil initiatives of stabilization if not properly met with adequate security forces. These capabilities must remain integrated throughout the extent of stabilization operations and the creation of separate stabilization command authorities convolutes necessary unity of effort.

The Army's force structure presentation at National Defense University cited the maneuver enhancement brigade as being capable of providing the following specialists to a stability environment:<sup>158</sup>

- up to 1250 Engineers
- up to 1200 MPs
- 550 Chemical personnel
- 1,400 Protection and Security personnel
- 32 Civil Affairs specialists

This is misleading. The MEB does not have a standing operational capacity. The numbers above are an example of what *could* be provided under a singular brigade command as an independent stability operations headquarters or in support of larger operations. It is a skeleton headquarters—a reserve—ready to receive attachments during a time of need. This unit was designed to be an adhoc organization from the onset. It is one of many redundant commands inherently built into the current brigade-modular design.

#### **E. MAAGS, FLAGS, STEGS, AND CORDS**

One of the most recent, and specific proposals to altering the Army's force structure has been presented by Andrew F. Krepinevich, Nadia Schadlow, and Marin J. Strmecki.<sup>159</sup> Their proposal is meant to be a "rough cut" at addressing the implications of *DoD Directive 3000.05* on Army doctrine, force structure, and capabilities, noting that "SSTR operations will dominate U.S. security challenges over the foreseeable future."

---

<sup>158</sup> Walker, "Army Force Structure and Implementation of Directive 3000.05," slide 12.

<sup>159</sup> Krepinevich, "SSTRO: Meeting the Challenge."

The proposal recommends the creation of Military Assistance and Advisory Groups (MAAGs) to be established as field commands for SSTR operations. Serving under the MAAGs would be Forward Liaison and Assistance Groups (FLAGs); Security Training and Equipping Groups (STEGs); and Civilian Operations, Reconstruction, and Development Support (CORDS) Groups. The FLAGs would be brigade-sized elements optimized for conducting SSTR operations. The study cites the following capabilities as essential for these operations: robust intelligence units, infantry, military police, special operations forces, construction engineers, civil affairs specialists, PSYOPs, quick reaction force elements, advisory teams, and transportation, communication, and logistics elements. The STEGs would be standing advisory groups. The CORDs would be robust organizations of civilian and military personnel. Like their Vietnam-era namesake, CORDS Groups would develop and implement reconstruction and development plans with “flexible funds and procurement rules.”

The *Army Action Plan for Stability Operations* includes a recommendation to assess Krepinevich’s ideas.<sup>160</sup> However, two months earlier, the Army’s Joint Staff had (unofficially) already dismissed his proposal as subjective, with no verifiable analysis. According to the Army G-3/5/7, “the roles of the MAAG are being largely subsumed by the JTF...the mission of the FLAGs has been addressed through modularity in the BCT and CSB structure and full spectrum operations doctrine...[and] those programs outlined for execution by the CORDs have been subsumed by the CA, USACE, and the interagency.”<sup>161</sup> This may be a simplistic initial response. In particular, the Army’s claim that capabilities called for by Krepinevich’s FLAG concept are already found in the modular brigade system is misleading. A closer look will reveal extensive shortcomings of critical specialties that must be sustained throughout steady-state operations.

---

<sup>160</sup> Department of the Army, G-3/5/7, Strategy, Plans and Policy Directorate, Stability Operations Division (DAMO-SSO), *Army Action Plan for Stability Operations, Army Campaign Plan Decision Point 105* (Washington D.C.: Department of the Army, August 2, 2007), 13. The document states: “follow-on analyses should address the issue of specialized versus full spectrum BCTs for select SO tasks, to include concepts of Military Assistance and Advisory Groups, Forward Liaison and Assistance Groups, Security Training and Equipping Groups, and Civil Operations, Reconstruction, and Development Support Groups.”

<sup>161</sup> Walker (NDU take-home CD), slide 87.

Yet, for all its ingenuity, Krepinevich's concept yields questions about coordination. Similar to Barry's proposal, each of these organizations would have people working in the same geographical areas. Ad hoc working groups, fusion cells, liaison officers, and committees would have a difficult time coordinating operations in a given area. Stove-piped, compartmentalized units would likely discourage effective information sharing, collaboration, and unity of effort.

#### **F. IDEALIZED MEDIUM-WEIGHT FORCES?**

Thomas Hammes not only articulates an acute assessment of the future threat environment, his book emphasizes the need for a force structure that embraces future unpredictability and is organized with greater built-in flexibility.<sup>162</sup> Hammes states, "we have too many heavy ground forces and way too many heavy reserve forces for any foreseeable fight. Yet the military is short of the flexible, multi-mission, medium-weight forces we need for forward presence, quick response, nation building, and peacekeeping or peace enforcement missions. In fact, it faces a critical shortage of such forces today in Iraq and Afghanistan."<sup>163</sup> Though he concedes further details are necessary, Hammes outlines general characteristics for an idealized medium-weight unit that provides a sound basis for further development. At first glance, one may think of the Stryker units. While they offer a starting point, they too have limitations (and in the case of vehicles—excesses) that will be explored in the next chapter. They still require substantial attachments to account for non-combat specialties and their limited number will unlikely be increased to prevent funds devoted to the future combat system (FCS) program from being reallocated. Hammes' recommendations include:<sup>164</sup>

- Creating lean headquarters capable of integrating interagency liaisons and operations, limit inefficiencies, and focusing on supporting a networked, mission-oriented force by reducing excess staff overheads.
- Maintaining force structure balances to excel against guerrilla street fighters and mechanized conventional enemies.

---

<sup>162</sup> Hammes, *Sling and the Stone*, 232.

<sup>163</sup> Hammes, *Sling and the Stone*, 261.

<sup>164</sup> Hammes, *Sling and the Stone*, 260-267.

- Easily deployable and prepositioned expeditionary forces.
- Large infantry and military police units to “secure and pacify both heavily populated areas and remote areas” after the conventional fight is over. Hammes further notes that the infantry units must be “capable of operating as small units to patrol, outpost, and finally to live with and advise counterpart units of an indigenous force.”
- Robust intelligence sections with an “emphasis on HUMINT and cultural intelligence rather than technical intelligence.”
- Increased numbers of civil affairs capable of operating joint, interagency, and in hostile environments. They must be able to handle critical governmental service functions and transition these functions to other agencies and indigenous offices.
- Forces must be networked, flexible, and able to operate on commander’s guidance without direct command and control.

## **G. TRENDS**

While the idea of transformation is evolving, the Army’s organizational structure below the brigade level is not. Many theories have been proposed to enable the United States to conduct more effective stability and counterinsurgency operations. These authors make sound arguments for change and provide generic theoretical models. However, they propose a radically-bifurcated force structure that could lessen the Army’s strategic flexibility and create unnecessary (and costly) force redundancy; they do not offer enough detail from which to make acute recommendations for the Army’s restructuring at the tactical level; or their concepts promote highly-compartmentalized functional groupings that would require tedious and centralized collaboration to properly integrate diverse capability effects. Because these analysts are providing conceptual designs for strategic or operational levels, the subtleties of ground combat are ignored. Most of the proposals for bifurcations in force structure that establish specific cabinets, joint commands, or divisions designed exclusively for stability operations, ignore (or at least marginalize) the hostile threats involved in these fragile environments. Some of the studies mistakenly suggest a sequential approach to military operations with clear transitions between combat forces and stabilization forces within specific time and spatial divides. The divide between combat operations and stability operations is not as clear as

in the days of uniformed symmetric battles between conventional forces, often ending in symbolic and internationally recognized surrender agreements. Even with “security augmentation,” many of these proposals do not place enough emphasis on proper security and population control, a critical condition to further political, economic, and civil development.<sup>165</sup>

Forces must be tailored to maintain security *and* conduct stability operations such as providing essential services, building partner security and host nation governing capacities, and promoting economic growth. These operations must support high-level goals and plans, yet be tailored to the nuances of a local area and society. Concepts that integrate population-focused capabilities with security elements throughout all levels of command should be explored.

Secretary Gates’ military assistant, Lieutenant General Peter Chiarelli and the current Secretary of the Army, General Casey, reportedly reject any proposals for plans that discuss optimizing any portions of the Army for irregular warfare.<sup>166</sup> They continue to emphasize full spectrum capabilities, frequently perceived as a euphemism for the current Army design. This study supports the notion that all forces must be full-spectrum “capable” as described in the forthcoming *FM 3-0*, able to conduct offensive, defensive, and stability operations. However not all units should, or can, be structured to do all things equally well. The previous chapter demonstrated stark discrepancies between heavy, Stryker, and infantry BCT proficiencies. As such, there is a vast opportunity for components of the overall force structure to be better optimized for irregular warfare. The next chapter will begin to explore these opportunities.

---

<sup>165</sup> A popular, albeit controversial author who emphatically stresses the preeminence of small-unit security operations is Bing West. See, Bing West, “The Coming Crash: Two Strategies on One Budget,” (PowerPoint presentation, NDU course, “Force Structure for Stability Operations and Interagency Integration,” May 24, 2007). He has also authored “Rediscovering the Infantry in a Time of Transformation,” *Defense Horizons* no. 10 (March 2002); and *Village Wars*.

<sup>166</sup> Peter Spiegel and Julian E. Barnes, “Rethinking the U.S. Army,” *Los Angeles Times*, October 10, 2007. See also, LTG Peter W. Chiarelli and Stephen M. Smith, “Learning from our Modern Wars: The Imperatives of Preparing for a Dangerous Future,” *Military Review*, September-October (2007). Chiarelli states, “We simply don’t have the resources to divide the military into ‘combat’ and ‘stability’ organizations. Instead we must focus on developing full-spectrum capabilities across all organizations in the armed forces.”



## V. ANALYSIS OF THE CURRENT DESIGN FOR IRREGULAR WARFARE

There's much more of a recognition within the Department of Defense that transformation has to be cultural transformation, organizational transformation, transforming the kind of skill sets that we have. But...I'm not sure that I see it actually being carried out to the extent that it ought to be.<sup>167</sup>

The Army has maintained its position that the current brigade-modular design is appropriately suited for stability operations, counter-insurgency, and other forms of irregular warfare. There are explicit references in the *Transformation Roadmap* and *Guide to Modularity* that the BCT is aptly suited for stability operations, although these claims have been widely disputed within DoD and from outside critics. According to a recent Congressional Research Service report, the Army “asserts that Army modular forces deployed to Iraq and Afghanistan in comparison to non-modular brigades, have proven to be equally as effective in conducting combat missions, more capable in conducting stability operations, and far better at interacting with other Services’ forces.”<sup>168</sup>

While the new BCT design may be performing better than its division-centric predecessor, organizational theory, historical insights, and recent experiences in Iraq and Afghanistan suggest the potential exists for further structural changes to better optimize the Army (or a portion thereof) for irregular warfare. In August 2007, the *Army Action Plan for Stability Operations* was issued to serve “as the plan for improving Army capabilities and capacities to execute stability operations, as well as for implementing

---

<sup>167</sup> Boot, (Comments at the Council on Foreign Relations).

<sup>168</sup> Nina M. Serafino, *Peacekeeping and Related Stability Operations: Proposals for Army Force Structure Changes* (Washington D.C.: Congressional Research Service, July 2006), <http://www.fas.org/sgp/crs/natsec/IB94040.pdf>. Serafino’s information stems from “unspecified discussions with and briefings from the Army staff between December 2005 and February 2006.”

DoD Directive 3000.05.”<sup>169</sup> One of the plan’s purposes is to ensure the “Army force structure is organized and equipped to execute stability operations as part of full spectrum operations across the spectrum of conflict.” The plan calls for a “review of division, corps, and theater army design for sufficiency of staff elements’ capability to plan for and conduct SO throughout all phases of an operation,” but does little to encourage explicit discussions about staff capacities or operational capabilities at the company, battalion, or brigade level.<sup>170</sup>

Maneuver battalions and their subordinate units have had little or no change in their organizational design. The Army claims modularity provides increased flexibility by attaching specialized units to the BCTs, but numerous problems still exist. One problem is the lack of capacity in critical specialties. Badly needed capabilities are not being fielded at tactical levels in sufficient numbers. Many of these units reside in the reserves where they are difficult to mobilize,<sup>171</sup> or in compartmentalized support brigades, isolated from the BCTs they often support. Both cases lend potential problems for the BCTs and their attached functional specialists. A lack of integration makes cohesion problematic, and the inability to conduct combined collective training reduces performance. Lastly, many functional communities have not made significant enough changes in their selection, education, or training curriculums to provide real technological expertise in critical areas. For example—power and water infrastructure repair. To maintain modern-day relevancy, more changes are necessary.

This chapter identifies broad problems with the Army’s current force design. It begins with an analysis of the relationship between organizations and their environment. Then, two broad conceptual issues of organizational design are applied to the Brigade

---

<sup>169</sup> DAMO-SSO, *Army Action Plan*, xx. The plan establishes the Stability Operations Division (DAMO-SSO), organized under the Army G-3/5/7 Strategy, Plans, and Policy Directorate, as the Army lead for improving stability operations (SO) capability. The plan outlines a series of tasks such as recommending reviews of doctrine, specialized training programs, and staff capacities for SO planning.

<sup>170</sup> In fact, within the 38-page document, the only consistent discussion of the brigade combat team was in regard to increasing Nonlethal Individual Weapons Instructors Course (INIWIC) graduates. The *Army Action Plan* calls for extensive studies in areas such as intelligence and civil-military operations, but those studies are tasked to functional headquarters whose organizational interests may skew rational capability assessments.

<sup>171</sup> See also, Metz and Hoffman, “Restructuring America’s Ground Forces.”

Combat team: specialization (also known as task differentiation) and integration of capabilities. Related closely to integration are discussions regarding degrees of centralization within an organization. Lastly, these concepts will be applied to the three critical areas of analysis identified earlier in the paper: intelligence operations, security and mobility, and civil-military operations.

## A. THE ENVIRONMENT AND THE ORGANIZATION

To fight effectively under conditions of uncertainty and complexity, organizations must be flexible and agile. Flatter, or less hierarchical organizations are, in general, more capable of operating in uncertain environments than hierarchical organizations. Diverse capabilities at lower levels of command, to include all-service and all-arms, will increase the effectiveness, albeit not the efficiency of the force.<sup>172</sup>

Although stable organizations can operate in simple organizational forms, they must establish structures that cope with greater degrees of uncertainty if exposed to rapidly changing technologies or environments. Unstable environments require a greater degree of flexibility and adaptability. As organizations take on more tasks, increased specialization and diversified structures require new methods for vertical and lateral coordination. Instead of the traditional top-down pyramid, chains of command should become flatter (less layers of authority or a lower ratio of senior to subordinate units) and coordination should occur through a “network of horizontal relationships.”<sup>173</sup> The Army’s structure has remained fixed to its historical hierarchy and the ratio of subordinate maneuver units to each command headquarters is relatively unchanged.

In his seminal book, *The Structuring of Organizations*, Henry Mintzberg described numerous frameworks for organizations dependent on the amount of standardized work or skills necessary, levels of formalization, and the amount of training required for its operational employees.<sup>174</sup> These organizations are each suited for particular environments. The Army’s operational environment can be viewed along two

---

<sup>172</sup> McMaster, *Crack in the Foundation*, 95.

<sup>173</sup> Lee G. Bolman and Terrence E. Deal, *Reframing Organizations* (San Francisco: Jossey-Bass, 2003), 61.

axes as depicted in Figure 19.<sup>175</sup> One axis measures environmental change. If environmental factors influencing an organization remain fairly unchanged over time, the environment is stable; the more they change, the more dynamic it is. Mintzberg suggests the more turbulent an environment, the more “organic” the organization must be—less standardized, allowing greater adaptation and innovation. Conversely, mechanistic organizations (common to stable environments) are more bureaucratic in nature. They rely heavily on standardized procedures, rules, and job descriptions. While less flexible, greater standardization generally allows greater efficiency and accountability.

Additionally, the environment can be viewed along an axis measuring the work an organization performs on a scale between simple and complex, corresponding to the diversity and difficulty of tasks being performed. Greater complexity usually drives organizations to decentralize authority and resources while encouraging greater skill specialization. When the environment is stable and tasks are simple and predictable, vertical coordination allows greater predictability and resource efficiency through standardized work processes. When the environment is dynamic and an organization’s work becomes more complex, its employees must be able to communicate laterally, mutually adjusting off each other’s successes and setbacks. Top-down directives work poorly in this environment.<sup>176</sup>

Leaders cope with ambiguous environments differently. Some try to make their environments simpler using technology and processes to centralize information management and decision authority. Others break complex problems into manageable pieces, assigning each piece to specialized units or individuals allowing increased decentralization.<sup>177</sup> While the Army is tacitly pursuing the former solution, it should consider a larger emphasis on the latter in an irregular environment.

---

<sup>174</sup> Henry Mintzberg, *The Structuring of Organizations* (New Jersey: Prentice Hall, 1979).

<sup>175</sup> Diagram modified from its original source: Eric Jansen, “Mintzberg Model,” (PowerPoint presentation, organizational theory course, Department of Defense Analysis, Naval Postgraduate School, October 14, 2006).

<sup>176</sup> Bolman and Deal, 56.

<sup>177</sup> Bolman and Deal, 30.

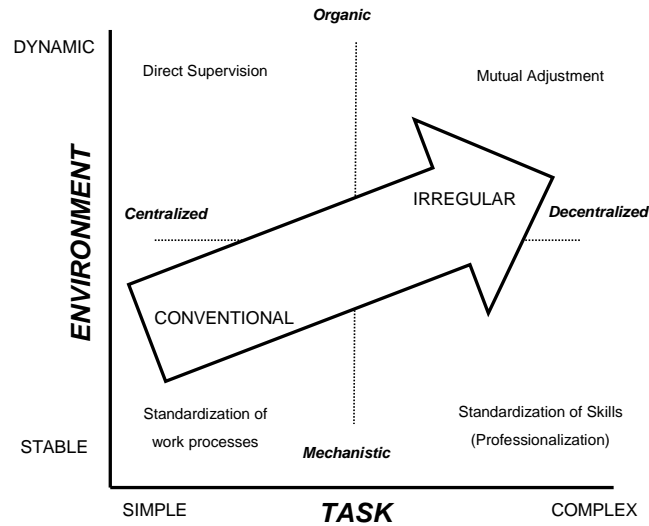

Figure 19. Mintzberg Structures

Mintzberg would describe the Army’s current design as a “machine bureaucracy.” It is centered on standardized work processes trained and evaluated through doctrine, Army Training and Evaluation Programs (ARTEPs), checklists, battle-drills, and rehearsed set-piece maneuvers. The Army maintains a high-level of centralization through a strict chain of command that is designed to expeditiously communicate information vertically through a host of managerial methods. This structure is ideal to produce management efficiencies and predictability, allowing numerous units and functional specialists to operate at relatively similar standards of performance and tasks.

As outlined in Chapter II, the external environment has changed. Over the last century, the United States Army has explicitly prepared itself for state-versus-state warfare on linear battlefields.<sup>178</sup> While conventional warfare will always have elements of uncertainty, the Army’s force structure, strategies, and tactical battle-drills were designed to combat fairly standardized enemy formations and tactics. Today, guerrilla and terrorist tactics by clandestine foes, the proliferation of communications technology and weapons materiel, and continued world urbanization, all work to create a future threat environment that promises to be increasingly turbulent. Compared to traditional

<sup>178</sup> Owens, “Counterinsurgency Comeback,” *Wall Street Journal*, September 6, 2007.

conventional warfare, irregular environments present more external and unprecedented factors with which military units must contend. This shift means the Army must become increasingly more flexible and innovative than its current structure allows. The traditional military hierarchy and an over-reliance on standardized work processes should give way to increased specialization, education, and a more adaptable, professional force. Resources and authorities should become more decentralized.

## **B. SPECIALIZATION**

Irregular warfare requires an extensive list of new tasks to individual soldiers and leaders as well as collective proficiencies of the units. Not only are tactical units expected to maintain their traditional warfighting capabilities, they must learn a number of new skills. While commanders should have knowledge in all aspects of counterinsurgency, they can not be expected to possess in-depth doctrinal knowledge of every facet of operations. Training time is a finite resource—one that was already in short order when tactical units only trained conventional combined arms maneuver. The problem of skewed training priorities is magnified with irregular conflicts as the number of critical tasks leaders, staffs, and units must understand has rapidly expanded.

Irregular warfare may be intellectually more difficult than traditional warfare, yet competent specialists are rarely dedicated beyond the brigade level to assist commanders with planning and conducting these operations. While population specialists such as CA, PSYOP, and HUMINT teams may be temporarily attached to battalion or lower levels, many tactical officers must deal with a revolving door of assets as “the brigade moves them to priority areas.”<sup>179</sup> This may demonstrate an attempt at acute tailoring of limited personnel to tasks, but counterinsurgency depends on personal relationships with the local populace and protracted relationship building. When the focus is on the population, continuity becomes sacrosanct. During a recent conference, former brigade commander Colonel John Nicholson stressed decentralized execution and “collective genius,” noting

---

<sup>179</sup> Kyle Phillips, Captain (interview with author, August 24, 2007).

that “situational understanding was best at the lowest levels.”<sup>180</sup> Recognizing that counterinsurgency was a combined arms fight performed “at the squad through company level,” Nicholson advocated that those units be properly resourced. He further noted that “brigade, battalion, and company commanders work all lines of operations. They have to know governance, economics, and information domains.”

In an online article, Captain Jeremy Gwinn states “in today’s military, the requirement to conduct tasks far outside traditional specialties is an accepted reality.”<sup>181</sup> As a former company commander, he recommends “companies and platoons develop specialized capabilities organically. This is the primary level of activity in counterinsurgency and the level where tactical wins or losses contribute to the strategic outcome.” Gwinn recognizes the significant role CA, HUMINT, PSYOP, and other specialized units can play: “men and women in these units are specifically trained and absolutely critical to success.” However, he cautions that specialized teams are not always available and his soldiers “probably know the area and the people better than anyone else.” He offers numerous techniques for tasking selected soldiers to perform specialized duties such as serving as a “political and cultural advisor.” His suggestions exemplify the creative and adaptive spirit of the Army’s small-unit ground forces; but they should be given the resource support to do their jobs more effectively.

Greater individual technical abilities and cognitive aptitudes are required as tasks become more complex. This demands greater task specialization with individuals requiring increased education and training in their respective areas of expertise. As militaries have modernized, specialization has consistently been integrated at lower echelons of command. An infantry company commander should have a firm understanding of fire support and mobility and counter-mobility operations, yet he has a

---

<sup>180</sup> Comments by Colonel John Nicholson, former commander of 3<sup>rd</sup> Brigade, 10<sup>th</sup> Mountain Division (presentation at the Infantry Warfighting Conference on September 19, 2007, Ft. Benning, GA).

<sup>181</sup> Jeremy Gwinn, “Organizing for Counterinsurgency at the Company and Platoon Level,” *Small Wars Journal*, August 2, 2007, <http://www.smallwarsjournal.com/blog/2007/08/organizing-for-counterinsurgen/>. Gwinn outlines other concerns such as the possibility that soldiers “become reduced to just pulling security for the attachments while they do their jobs.” The availability of specialized units shouldn’t prevent all soldiers from being involved with civil affairs, information operations, or intelligence gathering, it simply helps direct their efforts.

designated fire support officer and a combat engineer squad leader that advise him on their respective capabilities. Company and battalion units require similar combined-arms integration with population-focused specialists.

Historical case studies, contemporary military doctrine, and a host of academic studies, continue to associate certain capabilities with counterinsurgency, stability operations, and other types of irregular warfare. The demand for these capabilities depends on the scope of U.S. intentions, the scale of operations, the threat environment, foreign infrastructure capacities, and a host of other factors. The *Irregular Warfare Joint Operating Concept* identifies necessary U.S. capabilities as follows:

...information operations to include deception and PSYOP; HUMINT network operations, collect and exploit information, produce and/or disseminate intelligence; provide security assistance, training, and advisory assistance to foreign security forces; continue to conduct lethal strikes; and be able to conduct joint net-centric operations that link globally distributed forces conducting IW.<sup>182</sup>

The *Joint Urban Operations Joint Integrating Concept* outlines the necessity for military police, civil affairs, psychological operations, public affairs, and civil engineers.<sup>183</sup> Additionally, immediate assistance to the local population may require enhanced logistics and medical capacities. Military analyst Andrew Krepinevich cites a need for robust intelligence units, infantry, military police, special operations forces, construction engineers, civil affairs specialists, PSYOPs, quick-reaction force elements, advisory teams, and transportation, communication, and logistics elements.<sup>184</sup>

The Army believes these capabilities are well represented in the functional and multi-functional brigades. Yet articles from ground-level practitioners and interviews with a range of Army officers, suggest many of these skill sets are still in short supply and functional compartmentalization requires high-level capabilities integration. Colonel Brian Watson recognizes one of the current design's shortfalls:

---

<sup>182</sup> DoD, *IW JOC*, 34.

<sup>183</sup> DoD, *Joint Urban Operations JIC*, 27.



The modular BCT does feature some organic military police, intelligence collection, signal, and combat engineer assets that were not previously organic to combat brigades. However, the current design of these units represents a minimalist approach, barely capable of accomplishing the tasks necessary to support combat operations—let alone the additional tasks required for stabilization.<sup>185</sup>

While there is a general agreement to increase the capacity and capabilities of certain population-focused specialists in irregular environments, there is continued disagreement over how to integrate those capabilities with traditional combat specialties such as the infantry.

### C. DECENTRALIZATION AND INTEGRATION

Tightly controlled, top-down forms may work well in simple, stable situations but fail badly in more fluid and ambiguous ones.<sup>186</sup>

A vast array of literature analyzes the need for effective organizations when conducting irregular warfare. Historians and analysts stress the critical importance of close coordination between foreign and indigenous militaries, police, and civil administrations from the senior levels of government down to the tactical level. Furthermore, years of counterinsurgency study demonstrate the importance of small unit operations and intelligence work over large-scale conventional operations during irregular conflict.<sup>187</sup> The resulting organization should promote decentralized decision-making while retaining lateral unity of effort in all operating areas to include security, economic development, intelligence, and political authority. Austin Long's compilation of RAND counterinsurgency studies notes the recent change of Army units from division units to separate brigades as "encouraging...but insufficient." He states:

---

<sup>184</sup> Krepinevich, "SSTRO: Meeting the Challenge." Numerous other authors and publications claim similar specialized capabilities are needed in greater numbers during COIN and stability operations. Also, see Alwin-Foster, Barry, Binnendijk, Gibson, Hammes, Ollivant and Chewing, Sepp, and *FM 3-24*.

<sup>185</sup> Watson, *The Case for Greater Stabilization Capacity in the Modular Force*.

<sup>186</sup> Bolman and Deal, 42.

<sup>187</sup> Austin Long, *On "Other War," Lessons from Five Decades of RAND Counterinsurgency Research* (Santa Monica: RAND, 2006). See also Boot, *Savage Wars of Peace*; Krepinevich, *The Army and Vietnam*; and John A. Nagl, *Learning to Eat Soup With a Knife, Counterinsurgency Lessons from Malaya and Vietnam* (Chicago: University of Chicago Press, 2005).

COIN is fought at the neighborhood and village level, and is ultimately won or lost by sergeants, lieutenants, and captains, not by colonels and generals. The current focus on force protection combined with a propensity for thinking in terms of high-intensity combat has meant that there is often less autonomy for these squad, platoon, and company leaders than successful COIN requires.<sup>188</sup>

United States Army and Marine Corps' doctrine also stresses small-unit capabilities:

Battalion-sized and smaller unit operations are often most effective for countering insurgent activities. Counterinsurgents need to get as close as possible to the people to secure them and glean the maximum amount of quality information...Brigades are usually synchronizing headquarters...The sooner counterinsurgents can execute small-unit operations effectively, the better.<sup>189</sup>

The *Joint Urban Operations JIC* recognizes that “ground forces should be trained to operate in a distributed manner at the small-unit level,” noting the highly compartmentalized nature of urban operations. Each local area is very nuanced requiring small-unit actions tailored to that area. Furthermore, the authors see the need for “robust, decentralized command and control of ground forces,” and the integration of diverse capabilities at “increasingly lower levels of application.”<sup>190</sup>

Despite all the discussion of small-unit operations and lower-level capability integration, the question remains as to whether the Army is actually enabling lower units to do their jobs. In *Full Spectrum Operations*, Major General Peter Chiarelli and Major Patrick Michaelis, recognize the importance of small-unit operations with innovative leaders, empowered by resources such as money and intelligence.<sup>191</sup> However, the authors cautioned against the Army's insistence on modularity believing the smaller division headquarters would lose “force multipliers, traditionally located at the division” causing increased friction and slowing the campaign's operational tempo. This observation may have had relevance in Baghdad in 2004, but it is contrary to the

---

<sup>188</sup> Long, 62-63.

<sup>189</sup> Army, *FM 3-24, Counterinsurgency*, 5-12.

<sup>190</sup> DoD, *Joint Urban Operations JIC*, 26-33.

<sup>191</sup> Major General Peter W. Chiarelli and Major Patrick R. Michaelis, “Full Spectrum Operations,” *Military Review* July-August (2005).

historical evidence presented by Martin Van Creveld. Noting “twenty-five centuries of historical experience,” he describes a trend of successful warfare being waged through decentralized command structures.<sup>192</sup> Van Creveld asserts, “greater certainty at the top (more reserves, superior control) is only bought at the expense of less certainty at the bottom.”<sup>193</sup> Chiarelli saw his headquarters’ role as “providing the tip of the spear with the information and actionable knowledge needed to determine the best course of action.” But many officers from the “tip of the spear” frequently complain of cumbersome headquarters unable to process and analyze information they send up, and unable (or unwilling) to provide the resources that would enable them to do their job better at the lower tactical levels.

The Army’s force structure relies on customized mission tailoring—the “plug-and-play” of modular units to a given environment. According to Van Creveld, an organization’s desire for “overall flexibility” (currently maintained by harboring specialized capabilities and equipment in functional brigades and higher echelon commands) actually contributes to greater centralization, higher decision thresholds, and increased requirements for information processing.<sup>194</sup> However, he further cautions that greater autonomy of decision authority is not sufficient to determine success. Units must be properly trained and resourced. This results in cohesive, self-contained organizations that reduce the requirements for top-level information processing.

Martin Van Creveld describes, “two basic ways of coping with uncertainty, centralization and decentralization.”<sup>195</sup> He outlines numerous implications for the organization of successful combat units. One refers to command authorities. It is “the need for decision thresholds to be fixed as far down the hierarchy as possible, and for freedom of action at the bottom of the military structure.” Another is for decentralized

---

<sup>192</sup> Martin Van Creveld, *Command in War* (Cambridge: Harvard University Press, 1985). Van Creveld uses extensive case studies to blend leadership psychology and organizational theory.

<sup>193</sup> Van Creveld, *Command in War*, 274.

<sup>194</sup> Van Creveld, *Command in War*, 270.

<sup>195</sup> Van Creveld, *Command in War*, 274.

resources: “the need for an organization that will make such low-decision thresholds possible by providing self-contained units at a fairly low level.”<sup>196</sup>

The current Army design is brigade-centric. Brigade combat teams have considerably larger staffs and organic assets than their predecessors. Some of the officers interviewed for this study felt the brigade staff is an essential lynch-pin to tactical operations. They believe the many resource-intensive lines of operations pursued in a counterinsurgency operation require extensive coordination between specialized units and individuals, grouped functionally, who operate at the brigade and higher levels. One officer said most of the current operating deficiencies he’s observed at the Joint Readiness Training Center are due to ineffective brigade staffs and poor management, not a lack of specialized capabilities.<sup>197</sup> He sees operational ineffectiveness as a training issue. He believes proper training and better knowledge of COIN doctrine will allow the brigades to provide “good products to the company-level.” However, he cautioned that “brigade staffs’ products are limited by the quality of information they’re receiving from the companies.” To this officer, the largest limiting factor of an effective brigade staff is the managerial abilities of its senior officers and the quality of information its receiving through the formal information channels. Better training and managerial capabilities are necessary to optimize the brigade staff’s potential.

While this observation has merit and is shared by many, it seems there could also be an organizational issue. If brigade staffs are overwhelmed by sheer volumes of information they’re attempting to process and analyze, the staffs may need to be increased, placing an even larger demand on managerial skills. One military intelligence officer said his brigade integration and analysis cell had to sort over 700 pages of information “coming in from every direction” in a 12-hour period.<sup>198</sup> While some see technology and connectivity as a means to decentralize, it can also empower greater top-level control through increased information demands that burden subordinate

---

<sup>196</sup> Van Creveld, *Command in War*, 270.

<sup>197</sup> Ulrich interview.

<sup>198</sup> Major John Ives, (interview with author, September 5, 2007).

organizations and micromanagement. Summarizing his observations of U.S. military staffs at work, a senior British officer wrote:

...if there was a common trend it was for micro-management, with many hours devoted to daily briefings and updates. Planning tended to be staff driven and focused on processes rather than end effect. The net effect was highly centralized decision-making...it tended to discourage lower level initiative and adaptability, even when commanders consciously encouraged both.<sup>199</sup>

These staffs are expected to process and analyze large amounts of information, synchronizing complex operations across a large geographic area. While senior-level effectiveness is critical, an alternative may be to decentralize greater responsibilities to lower commands.

If exercising central control over limited resources is one way of maximizing cost-effectiveness, distributing those resources among subordinate units may, by virtue of eliminating much of the need for planning, coordination, and internal communications, be another...distributing the resources may often be the more effective way to maximize cost-effectiveness.<sup>200</sup>

Supporters of the current design believe brigade-level synchronization is important to prevent lower commands from becoming overly myopic. Limited resources require brigade and higher staffs to establish priorities for specialized units, equipment, and operational funds, oftentimes resulting in high-demand assets being frequently moved to different areas as the situation dictates. These are relevant concerns, but they must be balanced with the longevity of personal relationships (both internal and external to the organization) necessary in population-focused operations. The Army must take a critical look at its available capacity for high-demand specialists, units, and the integration of those capabilities into tactical maneuver units.

So far, this chapter has used organizational theory to infer areas of further analysis within the Army's force structure. The most important points are as follows:

---

<sup>199</sup> Alywin-Foster, "Changing the Army for Counterinsurgency Operations," *MR*, 6-7.

<sup>200</sup> Van Creveld, *Command in War*, 271. Van Creveld uses extensive case studies to blend leadership psychology and organizational theory.

- A turbulent environment requires greater decentralization of authority and resources.
- Increased complexity within the operating environment requires an increase in the number and diversity of tasks required of units and individuals.
- While increased education and training curriculums can broaden leader skill sets (and should be aggressively pursued), training time is finite. The operating environment demands an increase in specialization.
- These diverse capabilities should be integrated at lower levels of authority, allowing localized tailoring, while maintaining the means to coordinate across lateral and functional divides.

The remainder of this chapter will examine three functions essential to Army combat units conducting irregular warfare activities—intelligence operations, security and mobility, and civil-military operations. Each functional area will be examined to discern what degree of specialization is required and how those functions should be integrated to make the Army’s tactical units more effective at conducting operations in irregular environments.

### C. INTELLIGENCE OPERATIONS

Because all echelons collect and use intelligence, all staffs are heavily involved in analysis. Units are simultaneously intelligence producers and consumers...battalion staffs often do not have the personnel to collect patrol debriefs, analyze incoming information from multiple sources, produce finished intelligence products, and disseminate products to appropriate consumers. In many cases brigade intelligence sections may also be inadequate for a COIN environment...There are also instances when analysts can be beneficial at the company level.<sup>201</sup>

Historical literature and contemporary doctrine stresses the critical importance of intelligence in population-focused operations such as counterinsurgency.<sup>202</sup> Intelligence drives tactical operations and successful operations result in a greater quality and quantity

---

<sup>201</sup> Army, *FM 3-24*, 3-162, 3-163.

<sup>202</sup> See David Galula, *Counterinsurgency Warfare Theory and Practice* (Westport: Praeger Security International, 2006); Komer, Krepinevich, Nagl, Krepinevich, Crane, Hammes, Sepp, Aylwin-Foster, Gibson, Ollivant and Chewing, and *FM 3-24*.

of intelligence. This dynamic is not unique to irregular warfare, but methods of collection, types of information, and how the information is processed, are vastly different from conventional operations.

Army intelligence manning allocations and processes are indicative of its legacy design. Information has traditionally been gathered through centrally controlled systems. It was disseminated through a series of briefings and reports where the enemy situation was boiled down to an overlay of red symbols and numbers. Imagery and signals intelligence was critical to identifying the disposition, location and strength of enemy combat units and command nodes. When fighting conventional foes on linear battlefields, human intelligence was often limited to detainee questioning and the rare occurrence where civilians could provide current information on enemy troop movements. Population centers and their inhabitants were to be avoided.

Enemy situational templates were developed through a top-down process of collection and analysis with limited bottom-up refinement. Battalion intelligence specialists were often relegated to information conduits. In addition to technological methods, specialists trained in reconnaissance and surveillance collected information on the enemy situation and reported it to a staff that consolidated the “common operating picture.” The staffs then sent this information to the maneuver units tasked with destroying the enemy elements. This process resulted in a present-day intelligence organizational structure that looks like an inverse pyramid.<sup>203</sup> There are little, if any, dedicated intelligence assets at lower echelons, while higher commands maintain sizeable staffs and collection systems.

While the Army has embraced the mantra of “every soldier as a sensor”, the current intelligence structure has only seen slight incremental changes from its Cold War predecessor. The 2004 *Transformation Roadmap* recognizes numerous changes necessary to an intelligence framework originally designed to provide top-down

---

<sup>203</sup> Division intelligence staffs are approximately 300-strong, brigades are 115, and battalions 8. Additionally, there are ten active-duty MI functional brigades, typically supporting division and corps-level operations.

information to maneuver units in linear battle; yet none of these solutions have been implemented below the brigade-level. Some of these solutions include:<sup>204</sup>

- “moving appropriate Army intelligence collection capabilities forward into the tactical maneuver forces”
- “providing additional analytic capability within maneuver units to enhance situational awareness”
- “increasing the number of intelligence personnel organic to the lowest level war-fighting units”

As noted in Chapter III, there are no technologies or intelligence personnel organic to maneuver platoons or companies, while the battalion headquarters is unchanged and under-manned with a small intelligence staff of approximately six to eight personnel.<sup>205</sup> Tactical Collection Teams (TCT)<sup>206</sup> typically remain under brigade or higher control, often reporting through a classified and rigidly compartmentalized process. Additionally, high demand technologies such as signal intercept capabilities are often maintained at the brigade and higher level, attached to battalion and lower levels intermittently. These systems have proven to be extremely influential while integrated into smaller unit tactical operations.

Reconnaissance, surveillance, and target acquisition (RSTA) squadrons boast intelligence and maneuver integration offering a possible exception to stove-piped intelligence structures. Yet, these capabilities are confined to a separate battalion within a maneuver brigade. This is indicative of an organization still defined by linear battle-space. The *Guide to Modularity* states, “the reconnaissance squadron should be used in a security role only when that cannot be avoided.”<sup>207</sup> However, on the contemporary battlefield, this battalion is often given its piece of terrain identical to the other maneuver battalions, with each having similar tasks.

---

<sup>204</sup> DoD, *Transformation Roadmap*, 5-14, 5-15, 5-16.

<sup>205</sup> In the current environment, adhoc groups of untrained individuals at the company-level pour over information and forward their data to an undermanned intelligence cell at the battalion level. Increasingly and informally, units are attempting to overstaff themselves with officers to assist in the intelligence process. Email from CPT Neil Hollenbeck. His unit, 1-30 IN (Mech), deployed to Iraq in summer, 2007 with an additional lieutenant per company to serve as an intelligence officer.

<sup>206</sup> Formally know as Tactical HUMINT Teams (THT).

<sup>207</sup> Army, *Guide to Modularity*, 7-9.



There are numerous problems with the availability and allocation of current intelligence personnel and resources. (1) There are not enough specialists at lower command levels to process and properly analyze the extensive amounts of information being collected by the maneuver units. This information is bottle-necked at the battalion-level. (2) Information that is processed at the brigade and higher echelons is often incomplete. The individuals conducting analysis at that level are usually separated by layers of concrete, wire, and perimeter guards. They lack the nuanced understanding of a given area's terrain and population. (3) Intelligence received by special collection units at brigade and higher levels may not be actionable, or even relevant without the contextual information a more localized maneuver commander or embedded analyst would have.

In irregular conflict, vast amounts of information are gathered at the lowest levels by soldiers walking the streets, and platoon, company, and battalion-level leaders who have daily contact with the population. Their observations and conversations—conducted during patrols, chance encounters, and planned meetings—provide critical human intelligence. Metz and Hoffman summarize this notion in their call for additional intelligence personnel at lower levels within the military's hierarchy:<sup>208</sup>

The nature of irregular warfare reverses traditional intelligence collection requirements, which come from tactical units at the lowest levels of the military chain of command. The wealth of information gleaned from patrols and meetings with the local population must be fused with other surveillance means and law enforcement sources to produce meaningful insights.

Counterinsurgencies are traditionally dispersed operations with units being responsible for given areas of terrain and population over an extended period of time. Information has localized and sometimes timely context. Guerrillas may hide within the population, but not from it. Enemy situations often vary from neighborhood to neighborhood and town to town. Therefore, analysts must possess a detailed understanding of a given area's terrain, demographics, and population. For this reason,

---

<sup>208</sup> Steven Metz and Frank Hoffman, "Restructuring America's Ground Forces: Better, Not Bigger."

information must be processed and analyzed (at least initially) close to the point of collection and then passed to adjacent units.

In a recent survey of 109 combat-experienced company commanders, the “wartime experience” that ranked second-most challenging was developing their own “company-level intelligence cell or processes.”<sup>209</sup> One of the company commanders surveyed stated:

Our battalion has the best S-2 I have ever worked with, yet higher intel still fails us daily. It’s the nature of the war. In order to stay in touch with what is going on, I have always devoted hours daily to figuring out the terrain (people) in my sector. It’s a challenge to develop my subordinates and my command post to appreciate the importance of company-level intel processes, but we have developed some good ideas on how to battle this monster.<sup>210</sup>

Unable to handle the amount of information at their current skill capacity, companies sort information the best they can prior to forwarding it to battalion and higher levels. Essential information (or its contextual relevance) is frequently lost before it’s processed at the brigade level. Combined with a fluid environment that often requires a high operational tempo, information must be validated and processed into larger networks, much faster than current centralized structures allow. Numerous officers interviewed for this paper described brigade and division-level intelligence staffs generating target folders laced with inconsistencies—the details of which would only be known by someone acutely familiar with the area and its people.<sup>211</sup>

The Army’s counterinsurgency doctrine states, “enemy activities are more often reported by patrols, units conducting raids, or observation posts than they are by dedicated intelligence collectors.”<sup>212</sup> Lieutenant Colonel Douglas Ollivant and Captain

---

<sup>209</sup> *Army Magazine*, September 2007, 80. In a survey conducted by the CompanyCommand team of 109 combat-experienced company commanders, 58 stated “company level intelligence processes” as the area they needed the most assistance in. This was the second highest response out of 39 choices.

<sup>210</sup> CompanyCommand Team, “Leadership Challenges in Iraq,” *Army Magazine*, September 2007, 77.

<sup>211</sup> Interviews with CPT Ray Mattox, MAJ Morgan Southern, CPT Bob Gregory, 1LT Kyle Phillips, and CPT Nick Clemente.

<sup>212</sup> *Army, FM 3-24*, 3-167.

Chewing's account of operations in Iraq support this claim.<sup>213</sup> Most of their intelligence came from company and battalion-level leaders meeting regularly with influential locals. Likewise, platoon leaders and senior NCOs interacted with community members. Ollivant and Chewing discouraged further "outsourcing" intelligence gathering to young NCOs who reported directly to senior staffs.<sup>214</sup> Instead, they recommended increasing tactical HUMINT teams and attaching them directly to the battalion intelligence section to maintain a seamless relationship between intelligence and operations. Ollivant and Chewing feel HUMINT specialists play a critical and integral role in the time-consuming process of detainee interrogation, post-raid tactical questioning, source development, and intelligence analysis. However, they also argue for maneuver unit leaders (many of whom develop extensive relationships with local community leaders) to have formalized training, legal inclusions, and operational funds to properly conduct source operations themselves.

Former brigade commander, Colonel Ralph Baker stresses the importance of HUMINT-centric operations and offers numerous techniques for informant development, document exploitation, analysis, and effective interrogations.<sup>215</sup> However, he takes a very centralized approach to intelligence operations and offers little insight into his subordinates' informal methods of gathering and analyzing intelligence. To be fair, Baker claims he was eventually "able to back off and be less directive," allowing battalions and companies to modify their intelligence operations to suit their particular areas of operations. Yet the organization, reporting structures, and manning emphasis

---

<sup>213</sup> See, Ollivant and Chewing, "Rethinking Conventional Forces in COIN Operations," *Military Review*, July-August (2006): 50-59.

<sup>214</sup> See, "Army Looks for NCOs to Serve as Human Intelligence Collectors," *Army News Service*, March 28, 2007, <http://www.army.mil/-news/2007/03/28/2440-army-looks-for-ncos-to-serve-as-human-intelligence-collectors>. The Army has implemented a program to recruit additional 97-echoes (the designation for specialists trained to collect information from human sources, analyze that information, and conduct interrogations). Soliciting seasoned NCOs is an appropriate action on the part of the Army. In most traditional societies, age is an important factor of reverence. Indigenous persons will respond much better to a 35-year old than a 22-two year old. However, the recent goal of "100 [additional] staff sergeants and sergeants first class" is a trivial amount of personnel given the Army's needs. Additionally, the Army must better tailor human collection specialists to age, physical stature, and gender specific positions. Older, large, male interrogators command more respect with traditional societies; yet some women should continue to be recruited for women detainees interrogations and handling female sources.

<sup>215</sup> Baker, Ralph O, "HUMINT-CENTRIC OPERATIONS: Developing Actionable Intelligence in the Urban Counterinsurgency Environment," *Military Review*, March-April (2007).

presented in his article remain brigade-centric, designed to “ensure that the battalions’ intelligence and collection requirements were nested with the brigade’s.”<sup>216</sup> Intelligence should place less emphasis on bottom-level actions supporting higher-level situational understanding, and increase analysis that supports bottom-level actions.

At the 2007 Infantry Warfighting Conference, Brigadier General Yarborough stated that Iraq was a “company fight.”<sup>217</sup> “I get over half of my intel from the company level,” he said, and recalled a story about a company commander in Baghdad who awoke one morning to sixty-three missed cell phone calls from local Iraqis. In BG Yarborough’s opinion, company-level teams needed greatly enhanced intelligence gathering and analytical capabilities to include: tactical HUMINT teams, including interrogation specialists, signals intelligence, and intelligence-surveillance-reconnaissance capabilities (ISR).

Former battalion commander Christopher Gibson states, “experience has shown that effective targeting should be, in the main, driven by intelligence garnered by troopers interacting respectfully and empathetically with the populace.”<sup>218</sup> He advocates for numerous organizational reforms at lower levels. He calls for an overdue necessity to redistribute intelligence assets stating, “companies and battalions plainly need more intelligence analysts.” He specifically recommends that there should be tactical HUMINT teams and a dedicated interrogator at the battalion level, and intelligence analysts at the company level.

---

<sup>216</sup> If a brigade-level commander is personally involved with each facet of intelligence operations, one must question the overall effectiveness of the subordinate units’ gathering techniques. Baker’s insights are very informative, but the methods for reporting and analysis seem applicable to a unit with a slow operational tempo, or a rigidly hierarchical C2 system. Baker states, “the brigade’s intelligence sections developed a rapport with three to five informants who consistently provided reliable information.” With limited contacts it seems evident that the brigade commander would be able to receive weekly briefs on the “recruitment and development of informants.” However, as units become more adept at HUMINT-centric operations, the necessary resources for intelligence collection and analysis must be provided to lower command levels. Some of the leaders interviewed described platoons and companies with informants in the double-digits. That could equate to hundreds across a brigade task force. Bottom-up information collection is essential to COIN. Therefore bottom-up analysis with upper tier synthesis is necessary for effective operations.

<sup>217</sup> Brigadier General Yarborough, Multi-National Corps Iraq (presentation at the Infantry Warfighting Conference, September 18, 2007, Ft. Benning, GA).

<sup>218</sup> Lieutenant Colonel Chris Gibson, “Battlefield Victories and Strategic Success: The Path Forward in Iraq,” *Military Review*, September-October (2006): 47-58.

While tactical units are developing information for their designated areas of operations, higher echelons must still fuse it into operational intelligence.<sup>219</sup> Although most modern insurgencies are fractured and localized, there are social networks, financing chains, and ideological catalysts that extend throughout larger regions. Populations and enemy insurgents are not constrained by U.S. unit boundaries. Collective databases and higher-level analysis should provide critical synthesis, and cross-reference intelligence from military units, host-nation security forces, other U.S. government agencies, and intelligence organizations. Yet, the higher one goes, the less familiar staffs are with the subtle intricacies of a given area and population.

A recent RAND study on counterinsurgency discussed the necessity for all-source intelligence coordination at every echelon of military command, recommending intelligence centers at each level of organization from the village and neighborhood, to the national level.<sup>220</sup> It also warns that the intelligence community is fiercely resistant to decentralized initiatives. Intelligence organizations declare source protections, collection method sensitivities, and other important but often exaggerated legalistic minutia. Ollivant and Chewing believe unnecessary legal restrictions prevent seasoned leaders from tasking willing cohorts into gathering sensitive information.<sup>221</sup>

Critics of decentralized intelligence assets believe unfettered universal data access in the virtual realm will make geo-spacial concerns obsolete. According to one MI officer:

[Transformation] is enabling the tactical force with network connectivity so that [the] smartest people can collaboratively attack any problem from any location in the world. Do we still need MI assets and analysts forward? Absolutely! Does the analyst need to be standing in your tactical operations center in order to provide critical input as part of your collaborative team? Absolutely not!<sup>222</sup>

---

<sup>219</sup> Army, *FM 3-24*, 3-164.

<sup>220</sup> Long, 62.

<sup>221</sup> Ollivant and Chewing, "Rethinking Conventional Forces in COIN Operations."

<sup>222</sup> Brad T. Andrew, "Changing the Fundamentals of Intelligence," *Military Intelligence Professional Bulletin*, January-March (2003), [http://www.findarticles.com/p/articles/mi\\_m0IBS/is\\_1\\_29/ai\\_97822101/print](http://www.findarticles.com/p/articles/mi_m0IBS/is_1_29/ai_97822101/print).

Without a doubt, reach-back capabilities are already improving intelligence sharing. Yet, digital intelligence networks' databases are only as good as the quality of the information entered into them. The information must be continuously updated to remain relevant, and that has to be done by those who walk the streets. However, specialists can help refine unfiltered information before it overwhelms the system, and quickly identify information gaps.

In a 2004 article published in the *Military Intelligence Professional Bulletin*, Lieutenant Colonel Iwicki states, the intelligence community “know(s) where the rubber meets the road and enabling tactical forces is the heart of what we are doing.”<sup>223</sup> He claims recent transformation initiatives are dramatically changing MI operations to tailor collection and analysis capabilities, particularly suited to meet asymmetric threats. However, the tone of the article focuses largely on “embracing Information Age processes and distributed network-centric operations.” Information technologies should be aggressively pursued, but the increased proliferation of technology should promote flatter command structures and lateral communications while still allowing top-level synthesis and coordination.

Databases and information management is another often-cited area of concern for practitioners of counterinsurgency with experience in Iraq and Afghanistan. Gibson stresses the usefulness of census data and detailed population databases.<sup>224</sup> Many units had social network and population reports with names numbering in the thousands. Attempting to update that information and continuously refine linkages between individuals is a full-time job. An online OPED by a returning soldier fumed at the lack of available common intelligence databases that could enable tactical units to laterally share information. “Multiple reporting chains, proprietary databases, and top-down solutions

---

<sup>223</sup> Stephen K. Iwicki, “CSA’s Focus Area 16: Actionable Intelligence...one year later,” *Military Intelligence Professional Bulletin*, October-December (2004), [http://findarticles.com/p/articles/mi\\_m0IBS/is\\_4\\_30/ai\\_n13822278/print](http://findarticles.com/p/articles/mi_m0IBS/is_4_30/ai_n13822278/print). Iwicki describes recent improvements and tests of the Distributed Common Ground System-Army (DCGS-A) that is intended to provide the future digital architecture for intelligence analysis breaking down previous “ownership” barriers between different collection systems and echelons.

<sup>224</sup> Gibson, “Battlefield Victories and Strategic Success.”

hinder our ability to understand our enemy,” wrote Eric England.<sup>225</sup> Nearly five years into the war in Iraq, every maneuver unit leader interviewed for this study mentioned their *own* programs, databases, and templates for tracking information.<sup>226</sup>

This section has identified numerous problems with today’s intelligence structure. The current design runs counter to Army doctrine, historical insights, and comments from the field. The following chapter will provide a detailed recommendation for creating enhanced intelligence capacities within company and battalion units. For now, the attention will turn to security operations—the necessary foundation for development and the establishment of an environment that allows accelerated transitions to civil and legitimate host-nation authorities.

## **D. SECURITY AND MOBILITY**

Whatever weapon dominates the battlefield, there will always be times and places where vehicles cannot travel, shells and missiles cannot reach, and electronic sensors cannot sense. There will moreover, always be men who, for reasons of poverty or strategy, prefer to fight their battles at the retail rather than the wholesale level. For this reason, there will always be a place for first-class infantry.<sup>227</sup>

### **1. Vehicles**

The population is the center of gravity in irregular warfare.<sup>228</sup> Future ground conflict will likely continue to be conducted against guerrilla fighters hiding among sympathetic or coerced populations. Population security usually requires soldiers to live amongst the population they protect (or if need be, control), but too large a signature (the

---

<sup>225</sup> Eric England, “Six Steps to Victory, The bottom-up plan to defeat the insurgency,” (unpublished article, email to author, November 16, 2006).

<sup>226</sup> There have been some recent attempts at developing a common software program to be used at the lowest tactical levels. TIGRNet is a program being developed by DARPA to store and analyze data related to operations, terrain, and the population. Enemy and friendly pattern analysis can be conducted while social networking programs assist in understanding the local population. The author tested this program on October 13, 2006. For further information see, Stew Magnuson, “Eyes Wide Open,” *National Defense* May 2007, 46.

<sup>227</sup> John A. English and Bruce I. Gudmundsson, *On Infantry* (Connecticut: Praeger, 1994), 177-178.

<sup>228</sup> See Army, *FM 3-24* and Galula.

visible size of units and the amount of space they occupy) can accelerate resistance movements. While most security work must be done on foot, protected mobility is still critical. Soldiers will need to balance mobility, firepower, and survivability, while recognizing that “sometimes, the more force [that] is used, the less effective it is.”<sup>229</sup> Hammes’ believes heavy divisions are overly expensive, largely ill-suited for urban and restrictive terrain, and their firepower is irrelevant against guerrilla fighters. Large fleets of heavy armor require massive logistics tails, represented by sizeable support units and overhead costs (personnel, materiel, financial). In urban stabilization operations, soldiers must minimize their signature, while possessing the means for safe transport and increased firepower when necessary. This is a delicate balance.

The current Army structure is separated by a heavy, medium and light divide. Each type of BCT is distinguished primarily by its mobility platform (or lack thereof). According to the *Army’s Guide to Modularity*, “all BCTs can execute full spectrum operations”—able to operate in any threat situation, geographical region, and task environment.<sup>230</sup> The BCTs are designed to complement each other in a diverse array of mission environments; yet each type of BCT was optimized for specific types of terrain and enemy threats as described in Chapter III. All BCTs are stated to have utility in stability operations although no particular design is optimized for it.<sup>231</sup>

The Stryker BCT provides the closest balance of infantry and mobile protection necessary for an irregular, urban environment. Unfortunately, Stryker units only account for eight percent of the active component’s brigade combat teams.<sup>232</sup> Creating more Stryker BCTs may not be a fiscal reality or an operational necessity. Having enough

---

<sup>229</sup> Army, *FM 3-24*, 1-27; and Eliot Cohen, Conrad Crane, Jan Horvath, John Nagl, “Principles, Imperatives, and Paradoxes of Counterinsurgency,” *Military Review* (March-April), 2006.

<sup>230</sup> Army, *Guide to Modularity*, Chapter 6.

<sup>231</sup> Army, *Guide to Modularity*, figure 6-1, 6-2. Some analysts believe the Stryker Brigades were designed for stability-type operations as well as rapid mobility.

<sup>232</sup> Six SBCTs out of 48 programmed Brigade Combat Teams. This allocation has changed little since General Shinseki and Secretary Thomas E. White’s announcements during the 2002 AUSA Convention. Four SBCTs were originally allocated for Geographical Combatant Command requirements, one to reallocate an armored cavalry regiment capability to the XVIII Corps, and one to the National Guard as a strategic reserve. See Dennis Steele, “Realizing the Army Vision,” *ARMY Magazine*, December 2002, [http://findarticles.com/p/articles/mi\\_qa3723/is\\_200212/ai\\_n9156918/print](http://findarticles.com/p/articles/mi_qa3723/is_200212/ai_n9156918/print).



vehicles to promise every soldier a seat, SBCTs maintain a large signature and logistics requirements as compared with the lighter IBCTs. Forced-entry operations and major combat requires rapid mobility (both strategic and tactical) for the entire task force, but sustained operations permit smaller, modular pools of vehicles to support localized troop patrols. Furthermore, the SBCTs still lack the capacity for proper low-level intelligence operations and the many non-combat aspects of irregular warfare.

Heavy brigades make up forty percent of the active Army's BCTs.<sup>233</sup> The protracted and extensive use of heavily-armored, tracked vehicles can be detrimental to counter-insurgency operations.<sup>234</sup> The vehicles cause excessive damage to a town's surface and sub-surface infrastructure. They do not allow for the use of "minimum necessary force" when in contact and they limit interactions between soldiers and the populace. Lastly, armor can be psychologically menacing to local citizens, accelerating feelings of oppression and fueling resistance movements. The extensive use of heavily-armored vehicles increases budgetary requirements and support personnel reducing the number of combat troops on the ground.<sup>235</sup> Given the amount of their logistics overhead, the vehicles offer a very low "tooth-to-tail" ratio in a usually manpower-intensive operating environment.

While many armored units have adapted themselves to counterinsurgency, the old adage "if your only tool is a hammer..." may apply. During the first six months of operations in Ramadi, the 1<sup>st</sup> Brigade, 1<sup>st</sup> Armored Division fired over five-hundred 120mm main gun rounds. Noting his unit was a "hammer," and everything looked like a "nail" to his soldiers, Colonel MacFarland eventually mandated that a major or above had to approve the use of a main gun round.<sup>236</sup> As for collateral damage, the colonel stated

---

<sup>233</sup> 19 HBCTs out of 48 programmed active-duty Brigade Combat Teams.

<sup>234</sup> For a discussion in historical context, see Bound Report, *Review and Analysis of the Evaluation of the U.S. Army Mechanized and Armor Combat Operations in Vietnam*, U.S. Army Combat Development Command, 15 May, 1967, Copy #232.

<sup>235</sup> Twomey, "Cost of the Army."

<sup>236</sup> Because the approving officer was usually not on sight, approval was often differed to the requesting leader after insuring there were no "friendly's in the area." According to a former platoon leader interviewed for this paper who wished to remain anonymous, his tank platoon's battle-drill (automatic response) to an IED attack in a rural area was to fire a 120mm main gun round to the left and right of his convoy.

that “tanks crush infrastructure” and his units’ outposts became “swamps” due to broken water and sewage lines.<sup>237</sup> While almost all of the armor officers interviewed for this paper deployed with their full complement of Abrams tanks and Bradley fighting vehicles, many operated in HMMWVs. Yet, due to smaller personnel manning,<sup>238</sup> training deficiencies, or organizational resistance, some armored units were hesitant to conduct extensive dismounted patrolling—a necessary method for conducting community policing, speaking with locals, and gathering intelligence.

Conversely, most of the infantrymen interviewed wished they had more vehicles offering greater mobility and increased protection from mines, improvised explosives, and small arms. While they believed dismounted operations were essential to interacting with the public, a lack of vehicles limited their flexibility to react to attacks and conduct protected rapid movements of troops for selected operations. Alternative medium-weight vehicles are now under development to fit the immediate needs in Iraq.<sup>239</sup> These vehicles and others will likely remain in deployment pools for some time. An increase in medium-armored, wheeled vehicles should be expeditiously adapted into the standard organization of infantry units for training and wartime requirements. U.S. enemies have seen the vulnerability of U.S. light units in urban areas and will continue to exploit them.

---

<sup>237</sup> Comments by Colonel (P) Sean MacFarland, former brigade commander of 1<sup>st</sup> Brigade, 1<sup>st</sup> Armored Division, (presentation at the Infantry Warfighting Conference, September 19, 2007, Ft. Benning, GA).

<sup>238</sup> Armor units are technology centric and manpower short. An armor platoon consists of 16 personnel compared to a 39-person infantry platoon. An armor company consists of 67 personnel, compared to an infantry rifle company’s 141. Source: Army, *Guide to Modularity*, C-6, D-7. Armor has been used in dismounted operations, but at a much more limited scale than infantry units. Armor units are limited in personnel, but are maintenance, logistics, and cost heavy.

<sup>239</sup> The exact number of vehicles is unknown to the author. According to Anne Flaherty, Associated Press, “Pentagon seeks \$198B for wars,” *The Monterey County Herald*, September 27, 2007, A3, Department of Defense’s supplemental funding request for 2008 included \$11 billion for an additional 7,000 Mine Resistant Ambush Protected Vehicles (MRAP), in addition to the 8,000 MRAP vehicles already budgeted and planned for fielding bringing the total allocation to 15,000 vehicles. Another source, “Pentagon Requests Additional MRAP Funds,” *ARMY Magazine*, September 2007, 8, identified the total number of MRAPs in service at 500, with 6,415 additional on order. The military reportedly delayed large-scale production of an armored-HMMWV replacement because it did not expect the longevity of operations in Iraq and wanted to protect funding for “leap-ahead” capabilities under development such as the Marine Corps, Joint Light Tactical Vehicle program, or the Army’s Future Combat Systems family of concept vehicles. See, Peter Eisler, Blake Morrison, and Tom Vanden Brook, “Pentagon Balked at Pleas from Officers in Field for Safer Vehicles,” *USA Today*, July 16, 2007, 1.

In the next chapter, this paper will offer a standard force design to balance the demand for mobility, survivability, and firepower necessary for security duties, with the need for U.S. units to maintain a small signature and logistics tail. This lessens the population's resentment towards foreign troops and allows greater flexibility and autonomy for units operating in persistent irregular conflicts.

## 2. Military Police

“The primary frontline COIN force is often the police—not the military.”<sup>240</sup> This statement recognizes the significance of developing local security organizations that are accountable to government institutions and woven into the fabric of the environment in which they serve. However, many analysts equate “community policing,” or “police operations” in a counterinsurgency as analogous to a requirement for more military police (or contracted civilian law enforcement officers). In a hostile environment, the role of military police and infantry is oftentimes blurred. The *Stability Operations Army Action Plan* recommends the Joint Staff “assess the roles and missions of Military Police (MP) in order to determine what tasks may be executed by the GPF [used presumably to mean non-MP ground soldiers such as infantry or artillerymen] and what tasks require MPs.” Furthermore the action plan seeks to define a “clear distinction between criminal information/intelligence and police information/intelligence.”<sup>241</sup> The *IW JOC* says irregular warfare, “may require additional capabilities for police-like intelligence and security functions in support of population security and rule of law.”<sup>242</sup>

MPs have unique skill sets that can augment foreign police force training and support ongoing civil-military operations. Army counterinsurgency doctrine offers a list of skills that military police are “especially suited to teach” such as stations management, prisoner and detainee handling, and riot control.<sup>243</sup> However, other skills listed such as weapons handling, small-unit tactics, and raids are difficult (if not impossible) to

---

<sup>240</sup> Army, *FM 3-24, Counterinsurgency*, 6-19.

<sup>241</sup> DAMO-SSO, *Army Action Plan for Stability Operations*, xx.

<sup>242</sup> Army, *IW JOC*, 22.

<sup>243</sup> Army, *FM 3-24, Counterinsurgency*, 6-20.

differentiate from common infantry capabilities. Police take on more of a paramilitary role in a non-permissive environment. While all maneuver units and intelligence personnel are involved in policing duties, MPs should be able to provide more detailed investigations support to intelligence gathering requirements in an irregular operating environment. Lastly, women serving in military police units are a tremendous asset working with host-nation females from traditional societies. Female MPs can search indigenous women, question them out of sight of other males and escorts, or simply befriend them,

In a recent article, Colonel David Patton addresses the confusion that seems to exist over the current and future role of the military police.<sup>244</sup> Historically, the MPs were primarily responsible for handling enemy POWs, guarding, and facilitating the ground movement of critical supplies in rear areas. In garrison, they were charged with installation security, maintenance of law and order, and investigative duties. During the 1970s, the MPs dedicated themselves to rear battle tactics. According to Patton, “hours of training formerly devoted to garrison patrols, criminal incident response, and police report writing were given over to more hours on the ranges and in the field, learning the basics of moving, shooting and communicating necessary to fight and survive on the battlefield of Western Europe.” They focused on guarding rear-areas, protecting convoys, and directing military traffic. Through the last two decades, MPs have gradually been relieved of numerous home-station law enforcement duties by civilian contractors, while they focus on more infantry-like training. Meanwhile, non-linear conflict has altered the doctrine of rear-area duties.

Patton argues that the MPs niche’ is law enforcement and detainee operations. He cites Panama as a stability operation where “military forces were required to maintain law and order, sustain or restore basic services and nurture the development of new domestic civil institutions until they are prepared to take over these roles.” Among his numerous recommendations, Patton believes each BCT should have a dedicated MP company with platoons available to support battalion commanders in investigation

---

<sup>244</sup> Colonel David L. Patton (ret), “Put the ‘Police’ Back in Military Police,” *ARMY Magazine*, September 2007, 11-18.

procedures, law enforcement, and detainee operations. This proposal will become the basis for recommendations further outlined in the next chapter.

### **3. Combat Engineers**

Recognizing current and future “full-spectrum” operations concepts, the *Army Stability Operations Action Plan* calls on the engineer community to “ensure the proper skill sets are developed and available to meet the Army’s and the Nation’s needs.”<sup>245</sup> The engineer community has largely weighed its warfighting emphasis within its combat engineer units, steeped in infantry operations. They accompany tactical combined arms units, equipped and trained to reduce enemy obstacles while on the offense, and emplace their own while in the defense.

Guerrilla fighters of today, and potentially conventional adversaries of the future, will be less likely to establish large-scale, low-tech obstacles such as classic wire and mine obstacles. The increased proliferation of munitions and explosives technology and training is making concealed, highly-lethal, and very technical explosive devices more common. These devices have proven deadly against soldiers trafficking roads and entering houses. Engineers have knowledge on the construction of demolitions, but little training in explosive ordinance disposal (EOD). These specialists are in extremely limited supply in Iraq and Afghanistan today. The Army is exploring increased robotics technology that can detect enemies and explosive devices. Although this technology is immature at the moment, it hopes to deliver revolutionary capabilities. Combat engineers must revisit their capability mix, training emphasis and organizational structures to be more relevant in irregular warfare.

### **4. Advising Foreign Security Forces**

So far this chapter has focused solely on U.S. Army capabilities. Yet, one of the most critical steps following a U.S. foreign intervention is building, or strengthening, already established indigenous security forces capacity. More importantly, U.S.

---

<sup>245</sup> DAMO-SSO, *Army Action Plan for Stability Operations*, 18.

partnerships and multi-lateral exercises can provide preventive training opportunities to strengthen foreign militaries and police units, precluding some situations that would demand direct U.S. military ground combat. The necessity for building effective indigenous security force capacity during stability operations and counterinsurgency is rarely disputed; but, the method of organizing for this task is. Operations in Iraq and Afghanistan have witnessed dedicated advisory teams, special operations teams, informal assistance, and formal partnerships between U.S. and indigenous security units.

A thorough analysis of foreign unit training and leader advising is beyond the scope of this paper; however, one can not discuss irregular warfare without addressing this important component. The 2006 *Quadrennial Defense Review* states, “helping others to help themselves is critical to winning the long war.”<sup>246</sup> Current operations in Iraq and Afghanistan have demonstrated the importance, and difficulty, of establishing effective indigenous security forces to reduce the requirements of U.S. combat soldiers and to increase the legitimacy of the host-nation government.

While early efforts in Iraq usually relegated host-nation development to military transition teams (MiTT) teams at the battalion-level and higher, recent initiatives toward fully integrating conventional forces, the Iraqi army, and the Iraqi police at all levels of command have taken hold. Supporters of Baghdad’s Joint Security Stations (JSS) note the increased confidence and training the constant presence of U.S. troops embedded with the Iraqis provides. Small units of U.S. personnel integrated with the Iraqis merge U.S. advantages in close-air support and rapid reinforcements with Iraqi culture, linguistic, and intelligence collection benefits. A formal partnership of this type operates in the historical shadow of Vietnam’s Civilian Irregular Defense Group (CIDG) program and the Marine Corps’ Combined Action Platoon (CAP) program. Austin Long’s RAND report explains how combining U.S. squads with indigenous platoons makes an otherwise ineffective indigenous unit effective. Effective capabilities are essentially tripled.<sup>247</sup> *FM 3-24* declares that “U.S. combat operations are secondary to enabling the host nation’s

---

<sup>246</sup> DoD, 2006 *Quadrennial Defense Review*, as quoted in *FM 3-24, Counterinsurgency*, 6-1.

<sup>247</sup> Long, 64.

ability to provide for its own security.”<sup>248</sup> This statement, while unanimously accepted in word, has had a mixed following in deeds.

Critics of the MiTT program point to a lack of proper selection criteria for this essential job despite a doctrinal and senior leader adage that, “commanders must assign the best qualified Soldiers and Marines to training and advisory missions.”<sup>249</sup> Selection for a MiTT assignment has normally relied on “dwell time,” a personnel policy that often ensured officers and soldiers with the least experience would be selected for this critical duty and offers little quality control over the selection process.<sup>250</sup> A recent graduate from Fort Riley’s training program tasked to prepare MiTT teams for deployment, lamented that most of the program’s curriculum was spent refreshing basic soldier skills.<sup>251</sup>

Special Forces teams are inherently organized for advising indigenous forces at the tactical level.<sup>252</sup> However, 11-man ODA teams are not designed nor experienced enough to provide the scope of capabilities required when advising higher-level commands within institutionalized armies on logistics, maintenance, and personnel systems, legal processes, and staffing systems. As the U.S. Army Special Operations Command is exploring the clandestine side of unconventional warfare and persistent, low-visibility operations,<sup>253</sup> the *IW JOC* and the *Army Action Plan for Stability*

---

<sup>248</sup> Army, *FM 3-24, Counterinsurgency*, 6-2.

<sup>249</sup> Army, *FM 3-24, Counterinsurgency*, 6-3.

<sup>250</sup> Email to author from Human Resources Command.

<sup>251</sup> Conversation with Infantry officer who wished to remain anonymous. See also, “Troops hit Midwest before Middle East,” and “Soldiers learn survival techniques,” *AUSA News*, August 2007, 9-13. For a MiTT leaders perspective on the training program, see Major Scott A. Shaw, “Taking the Mystery out of the Fort Riley MTT Training Experience,” <https://cp.army.mil/CommunityBrowser.aspx?id=57600&lang=en-US>.

<sup>252</sup> Sepp, “Best Practices,” 10. Also, Department of the Army, *FM 31-20-3, Foreign Internal Defense: Tactics, Techniques, and Procedures for Special Forces* (Washington D.C.: Government Printing Office, September 1994).

<sup>253</sup> According to the *2006 Quadrennial Defense Review* (44), “As general purpose joint ground forces take on tasks that Special Operations Forces (SOF) currently perform, SOF will increase their capacity to perform more demanding and specialized tasks, especially long-duration, indirect and clandestine operations in politically sensitive environments and denied areas.” See also, David Tucker and Christopher J. Lamb, “Restructuring Special Operations Forces for Emerging Threats,” *Strategic Forum* no. 219 (January 2006) to understand the growing bifurcation within the SOF community over “direct versus indirect” approaches to operations.

*Operations* encourage general purpose forces to increase its capability and capacity to conduct foreign internal defense (FID) missions.<sup>254</sup>

This is where the debate begins.<sup>255</sup> Military analysts such as John Nagl and Andrew Krepinevich argue for the creation of standing, full-time advisory units.<sup>256</sup> Critics are quick to point out that every advisory mission will be different. The existing capabilities (and short-falls) of the host-nation forces, scope and scale of U.S. involvement, and political situations may require vastly different skill sets by individual advisors or advisory teams. When the U.S. presence in Iraq and Afghanistan eventually subsides, permanent advisors will have difficulty sustaining their skill proficiencies. How those proficiencies would differ from those already existent in SOF is another issue. More important than a standing advisory force may be a competitive advisory selection process and tailored training as needed. Some of the more renowned advisors in recent history did not come from a standing organization, but possessed innate personality traits and existing skills that were critical to their efforts.<sup>257</sup> Nonetheless, through training, education, or structural changes, the U.S. Army must institutionalize and improve its ability to train and advise host-nation security forces. Next, the Army's capability and capacity to conduct civil-military operations is examined.

## **E. CIVIL-MILITARY OPERATIONS**

Besides intelligence and security operations, stability operations and counterinsurgency demand other skills and capabilities directed towards the population and indirectly, against U.S. enemies. In a recent *Military Review* article, Lieutenant

---

<sup>254</sup> DAMO-SSO, *Army Action Plan for Stability Operations*, 6.

<sup>255</sup> Peter Spiegel and Julian E. Barnes, "Rethinking the U.S. Army," *Los Angeles Times*, October 10, 2007.

<sup>256</sup> John A. Nagl, "Institutionalizing Adaptation: It's Time for a Permanent Army Advisor Corps," Center for a New American Security paper, June 2007), 2, [http://www.newamericansecurity.org/publications/Nagl\\_AdvisoryCorp\\_June07.pdf](http://www.newamericansecurity.org/publications/Nagl_AdvisoryCorp_June07.pdf); and Krepinevich, "Meeting the Challenge."

<sup>257</sup> For example, see Edward Geary Lansdale, *In the Midst of Wars, An American's Mission to Southeast Asia* (New York: Fordham University Press, 1991); David Donovan, *Once A Warrior King, Memories of an Officer in Vietnam* (New York: Ballantine Books, 1985); Ben S. Malcom, *White Tigers, My Secret War in Korea* (U.S.: Brassey's, 2003).



General Peter W. Chiarelli acknowledges numerous organizational changes the Army should explore—“...as the Army and Marine Corps increase their active-duty end strengths, we should consider increasing the number and adjusting the proportion of specialized units such as civil affairs, engineers, information operations, and others that play critical roles in stability operations.”<sup>258</sup> His comments echo those of other analysts and studies presented earlier in this chapter.<sup>259</sup> This section explores those authors’ calls for increasing the capacity of information operations, civil affairs, and engineers. In addition, these specialists must have the correct skill sets for the contemporary and future operating environments (not more of the same); and those capabilities must be properly integrated with those of the maneuver BCTs and its subordinate units. While this section provides an overview of each area, the next chapter will offer specific structural recommendations.

## 1. Information Operations

Information operations (IO) must be synchronized through all levels of operations to maintain communication consistencies.<sup>260</sup> Disseminating false or misleading information to the local populace can quickly undermine U.S. credibility in a given area. Units must “develop common, multi-echelon themes based on and consistent with host nation government policies and the operation’s objectives,” according to U.S. doctrine.<sup>261</sup> However, IO should by no means be limited to broad operational and strategic themes. At the tactical-level of operations in Iraq and Afghanistan, the desire to “sustain unity of message,” often results in an overly-restrictive approval process. An over-emphasis on consistency, unity, and coordination leads to messages perceived by the local public as

---

<sup>258</sup> Lieutenant General Peter W. Chiarelli and Major Stephen M. Smith, “Learning from our Modern Wars: The Imperatives of Preparing for a Dangerous Future,” *Military Review* September-October (2007): 7.

<sup>259</sup> See, the *Irregular Warfare Joint Operating Concept*, the *Joint Urban Operations Joint Integrating Concept*, Krepinevich, Watson, Binnendijk, Barry, and others.

<sup>260</sup> Using the term Information Operations in its broadest sense. This also includes psychological operations, deception, and public affairs.

<sup>261</sup> Army, *FM 3-24, Counterinsurgency*, 5-8.

vague, watered-down, or of no particular interest. Information operations strategies must not only provide “common, multi-echelon themes,” but offer information specific to local areas.

IO are tailored to address the concerns of the populace of specific areas. IO should inform the public of successfully completed projects and improvements, including accomplishments in security, infrastructure, essential services, and economic development.<sup>262</sup>

Additionally, the approval and production process for messages and products in Iraq and Afghanistan is disappointingly slow. One of the most consistent complaints from tactical operators is the bureaucratic cycle for product creation. As noted by Gordon England, “units are not permitted to create and distribute their own flyers without approval from the generals in Baghdad.”<sup>263</sup> He recommends enhanced leader training and more empowerment to local units allowing them to “develop and share a message that works in their neighborhoods,” stressing the importance of close communication between tactical units and Iraqi locals. Top-level control and the lack of production capabilities at the brigade and below level, leads to a lack of tailored messages, delayed and ineffective targeting, and an eventual credibility gap within U.S. operations.<sup>264</sup>

Colonel Ralph Baker vented his frustrations with the IO support his Brigade received in a 2006 *Military Review* article.<sup>265</sup> He described the support as “too broad to resonate with the diverse subpopulations.” Support and products “were typically approved too late to address the issue for which we had requested them.” Baker also described out-dated legal precedents, doctrinal gaps, and training deficiencies that prevented the proper execution of IO. He was frustrated at a process that regulated approval channels “at the highest command levels.” The asymmetry of irregular warfare

---

<sup>262</sup> Army, *FM 3-24, Counterinsurgency*, 5-8.

<sup>263</sup> England, “Six Steps to Victory.”

<sup>264</sup> CPT Ray Mattox, CPT Bobby Davis, and CPT Pete Rodgers, “Information Operations (IO), The Great Disconnect: National Strategic Policy Meets the Challenges of Tactical Implementation,” (PowerPoint presentation, Naval Postgraduate School, 2007). See also, Colonel Ralph O. Baker, “The Decisive Weapon: A Brigade Combat Team Commander’s Perspective on Information Operations,” *Military Review* May-June (2006); and, Chiarelli and Smith, “Learning from our Modern Wars.”

<sup>265</sup> Baker, “The Decisive Weapon: A Brigade Combat Team Commander’s Perspective on Information Operations.”

was evident. While the insurgents were quick to exploit the media and word of mouth to shape stories to their advantage, Baker's unit was hindered by a "procedure much too slow and cumbersome to support our IO needs at the tactical level." COL Baker had his own recommendations:

To overcome what was an ineffective and usually counterproductive attempt for IO/PSYOP agencies at higher levels of command to centrally control themes and messaging, we were compelled to initiate a more tailored IO process. We developed products that incorporated relevant themes and messages far more specifically for the diverse groups and micropopulations in our area of operations.

Besides training implications, Baker suggested the creation of an IO working group at the brigade level consisting of PSYOP and CA attachments, an intelligence officer, engineer officer, and the brigade fire support officer. Baker discouraged further decentralization of themes and product development due to the risk of "IO fratricide," citing an example of conflicting battalion messages following an operation.<sup>266</sup> However, numerous officers interviewed for this paper cited the same problems (broad-based themes, and time consuming approval processes) at the company and battalion levels.

Each environment will be different and unit competencies will vary, but the Army should explore procedures and organizational mechanisms to allow nuanced messages and products to be developed at the battalion (and possibly lower) level of command, while insuring consistency with higher-level themes, and accuracy with neighboring messages.<sup>267</sup> IO, like intelligence is a "commander's issue," and all soldiers have a role in the dissemination or collection of information—resident specialists can serve as advisors and capable subject matter experts.

---

<sup>266</sup> A notorious example of "IO fratricide" allegedly occurred in Afghanistan as reported by Bradley Graham, "Alleged Desecration of Bodies Investigated," *Washington Post*, October 21, 2005, A16. According to the article, a tactical psychological operations team and their parent infantry unit burned the corpses of two insurgents and then taunted other enemy fighters in an attempt to bait them into attacking. The desecration of bodies created a large blowback throughout the international community; however, it is an exception to otherwise moral, legal, and appropriate information operations being conducted by tactical units throughout Iraq and Afghanistan. Proper training and leadership can prevent most abuses.

<sup>267</sup> A similar recommendation was made by General Chiarelli when he stated, "public affairs officers should be assigned down to the battalion level and even company level for certain missions, and when they are, we need to give them latitude to publish new releases quickly and the support they need to overcome mistakes." Chiarelli and Smith, "Learning from our Modern Wars," 12.

## 2. Civil Affairs

Civil development methodology remains a largely debated topic. Some see heavy financial and material investments in supported-nation economies as a way of “winning hearts and minds.” Others advocate for the military’s role to be immediate emergency aide, leaving development to a community of international and U.S. humanitarian, non-government organizations (NGOs). The military often views NGOs with distrust, while the NGO community criticize the military for violating “humanitarian space.”<sup>268</sup>

Another debate involves bottom-up versus top-down methods of boosting economic growth.<sup>269</sup> Many military commanders pursue numerous, small-dollar, localized, and immediate impact projects, while regional and national leaders seek fewer, expensive, longer-term, and large-impact initiatives. Proponents of the first approach see funding programs such as the Commander’s Emergency Relief Program (CERP) as essential for them to apply a nuanced “carrot and stick” approach to counterinsurgency operations. In doing so, they weave the tenants of security and economic development closely together. The benefits of bottom-up, localized and sustainable programs have been increasingly promoted. Recently, top-driven, large-scale projects in Iraq have been increasingly questioned.<sup>270</sup> The *Army Action Plan for Stability Operations*, recommends

---

<sup>268</sup> See, Michael J. Dziedzic and Colonel Michael K. Seidl, “Provincial Reconstruction Teams and Military Relations with International and Nongovernmental Organizations in Afghanistan,” *United States Institute of Peace Special Report*, no. 147 (September 2005). See also, Robert M. Perito, “Provincial Reconstruction Teams in Iraq,” *United States Institute of Peace Special Report*, no. 185 (March 2007).

<sup>269</sup> For further discussion see remarks from Ambassador David M. Satterfield, Senior Advisor to the Secretary and Coordinator for Iraq, (State Department briefing and question session, February 7, 2007), <http://www.state.gov/p/nea/rls/rm/2007/80216.htm>. See also, Yochi J. Dreazen, “New Rebuilding Plan in Iraq Ignites Debate About Tactics,” *Wall Street Journal*, April 19, 2007, 1.

<sup>270</sup> See, James Glanz, “Inspectors Find Rebuilt Projects Crumbling in Iraq,” *The New York Times*, April 29, 2007; Office of the Special Inspector General for Iraq Reconstruction, “Erbil Maternity and Pediatric Hospital, Erbil, Iraq, Sustainment Assessment,” SIGIR PA-06-094, April 19, 2007, [http://www.sigir.mil/reports/pdf/assessments/PA-06-094\\_Erbil\\_Hospital.pdf](http://www.sigir.mil/reports/pdf/assessments/PA-06-094_Erbil_Hospital.pdf). Also, Ambassador Satterfield briefing.

For further discussion on fiscal decentralization see Pranab Bardham, “Decentralization of Governance and Development,” *The Journal of Economic Perspectives*, vol. 16, no. 4 (Autumn 2002): 185-205; and, Robert M. McNab and Edward Mason, “Reconstruction, the Long-Tail, and Decentralization,” Defense Resource Management Institute working paper, October 2006.

the Army “establish mechanisms through which USACE contracting capabilities can be used to support bottom-up, small scale solutions to economic and infrastructure problems.”<sup>271</sup>

Besides “civil affairs” as a capability, it also describes a military job specialty. Civil affairs specialists have received considerable attention in light of operations in Iraq and Afghanistan. A recent Washington Post article about Iraq quipped, “inexperienced soldiers do their best to scrutinize millions of dollars in contracts and monitor projects they don't fully comprehend.” Civil affairs soldiers interviewed said their training was inadequate for the tasks at hand. One NCO was quoted stating, “I wish they had taught me how to spend money.” The role of civil affairs is evolving. The selection, organization, and training methodology for those specialists is and should be scrutinized more closely.

Proponents of maintaining most civil affairs specialists in the reserve field cite civilian functional areas that complement their military duties. However, numerous conversations with civil affairs officers reveal anecdotal evidence that most CA officers are not utilized as functional specialists.<sup>272</sup> Yet, with proper training, they can provide maneuver commanders enhanced abilities to conduct analyses of populations, and serve as economic and governance advisors. Furthermore, increased training on project management, budgeting, and contract development would benefit the CA community. While maneuver commanders are becoming increasingly aware of the benefits of closely integrated lines of operations, maneuver forces lack specialized individuals and teams that can assist in developing host-nation governing capacity and serve as catalysts for economic growth.

Historically, civil affairs specialists were essentially liaisons between military units and the civilian community. Legacy civil-military structures were oftentimes based on linear battlefields where civil affairs specialists followed in the wake of military

---

<sup>271</sup> DAMO-SSO, *Army Action Plan for Stability Operations*, 18.

<sup>272</sup> Author's conversations with Major Cameron Sellers (Army Civil Affairs), and Colonel Ferdinand Irizary, former G3 USACAPOC and commander 95<sup>th</sup> CA Brigade, April 14, 2007.

maneuvers to establish control in recently liberated or still occupied areas.<sup>273</sup> Their role was to ensure order and minimize civil interference with military operations. They provided emergency humanitarian aid, controlled refugees, and interfaced with international and non-governmental organizations within each area of operations. For fifty years, civil-military operations have been executed through ad hoc organizational structures. After World War II, large-scale occupations were led by AMGOT (Allied Military Government of Occupied Territories) teams and a civilian administration. These teams operated separately from military units. In Vietnam, the Civil Operations and Revolutionary Development Support (CORDS) Program established civil-military teams, drawing members from DoD, the Department of State, and USAID.<sup>274</sup>

More recently, and common to modern irregular conflict, civil interaction can not be easily separated from military action. Interaction with, and influence over the population is a critical effort within irregular operations. While every soldier and officer must understand the relationship of civil-military operations through expanded training programs, specialized individuals and units are still necessary to properly advise maneuver leaders and collaborate with non-military organizations.

In Afghanistan and Iraq, provincial reconstruction teams (PRTs) have received a great deal of attention as the latest civil-military concept. Although common in name, the teams do not have a unifying structure, manning requirements, or mission. They represent continued ad hoc units established to conduct focused reconstruction programs and governance development. While PRTs in Afghanistan operate mostly in permissive, or semi-permissive environments, many of their Iraqi counterparts have been “embedded” into brigade combat teams as part of General Petraeus’ counterinsurgency

---

<sup>273</sup> Although a fictional account, John Hersey’s, *A Bell for Adano* (New York: Vintage Books, 1988), provides a detailed account of civil-military relationships in WWII Italy.

<sup>274</sup> See, Robert W. Komer, *Bureacracy at War: U.S. Performance in the Vietnam Conflict* (Boulder: Westview Press, 1986), 119. Established in 1967, this program blended numerous “pacification programs” that were ongoing. Civil-military advisory teams were established in 250 districts and 44 provinces. However, the program has a controversial history. Some point to it as a beneficial program, simply initiated too late in the war. Others recognize the program’s potential, but claim its adhoc nature prevented it from receiving adequate funding and manning to make a lasting change. Another criticism of the program was allegations that USAID simply served as a cover for intelligence gathering, not an agency for economic development.

strategy. This program acknowledges the reality of irregular conflict—military and civil objectives are explicitly interdependent at all operational levels. Military activities and civil-military duties do not easily differentiate into separate organizations. Having combat units and disconnected PRTs serving in the same area creates functional stovepipes that are ineffective, if not counterproductive, to operations. Integrating the civil specialists and maneuver commanders at every echelon promotes increased unity of effort.<sup>275</sup> Although the PRT concept may not survive operations in Iraq and Afghanistan (its namesake is already being replaced by Provincial Support Teams [PST] and State Department-led Forward Advanced Civilian Teams [FACTs]), the means by which civil specialists can be formally partnered with maneuver units should continue to be explored.

Although civil development methodology and civil affair's training are fields of study in their own right, this paper is more concerned with the integration of civil affairs specialists and maneuver units. Ollivant and Chewing state, "the commander responsible for the security of a specific area must also be able to determine reconstruction priorities and control assets responsible for their implementation."<sup>276</sup> They support better resourcing tactical-unit commanders with reconstruction budgets and operational funds. Like many tactical commanders, they see money as influence with the local population. But money must be used wisely. Development projects and labor programs must be tied to information operations, security requirements, and intelligence. It must be sustainable by the locals and have a positive effect on economic growth. Unsustainable projects, with ribbon-cutting ceremonies as their end-state, should be avoided.

Many of the officers interviewed for this study agree with Ollivant and Chewing's belief that multiple lines of operations must be integrated at the lowest reasonable levels. Others question the suitability of decentralized civic action. General Chiarelli supported specialized task forces and units dedicated to each particular line of operation relying on division-level headquarters to synchronize these efforts.<sup>277</sup> General Petraeus also

---

<sup>275</sup> See, Kristin Hagerstrom, PRT team leader, and Major Lee Suttee, USMC Civil Affairs Chief, (State Department briefing via satellite, August 24, 2007), <http://www.state.gov/p/nea/rls/91450.htm>.

<sup>276</sup> Ollivant and Chewing, "Rethinking Conventional Forces in COIN Operations," 57.

<sup>277</sup> Chiarelli and Michaelis, "Full Spectrum Operations," 16.

organized his division's staff officers and non-maneuver commanders across functional boundaries within Mosul in 2003.<sup>278</sup> He ensured these civil, functional groupings closely coordinated with his brigades and battalions that were organized geographically—maintaining security through defensive measures, area-denial patrols and intelligence-driven raids. The success and longevity of their efforts is beyond the scope of this study. But generally speaking, higher-level decision-makers lack a detailed enough understanding of local-level nuances, to properly determine what mix of capabilities to employ in a given area with any precision. A senior commander's desire for efficiency through brigade and higher functional grouping results can lead to less effective operations.

Geographical grouping with integrated functional capabilities can better respond to local needs. Obviously, some top-level oversight will be necessary to determine resource priorities. Planning and prioritization may require higher levels of synchronization, but the details of execution must be maintained with lower-level commanders. Functional grouping of civil projects allows better synchronization for technical programs that transcend unit boundaries. Utility distribution is a good example of programs best aligned with functional specialists working at higher levels. However, localized, sustainable programs, particularly those that are labor-heavy, should be supervised by corresponding geographically-aligned maneuver units.

Currently, most brigades operating in Iraq and Afghanistan are receiving attached civil affairs companies. Most battalions have a CAT-A team attached. Some BCTs in Baghdad and Al Anbar province of Iraq have joint, inter-agency PRTs embedded with the BCTs. This provides an ideal environment to fuse security initiatives with other lines of operations such as economic development and governance capacity building. Yet, a common complaint is the lack of advanced, integrated collective training and the opportunity to build informal, interpersonal relationships between maneuver units and civil affairs attachments. CA teams frequently move as senior decision-makers continue

---

<sup>278</sup> Kirsten Lundberg, "The Accidental Statesman: General Petraeus and the City of Mosul, Iraq," Student case study, C15-06-1834.0, Kennedy School of Government Case Program, Harvard University, 2006.



to tailor their task organization to changes in their operating environments. While frequent changes in task organization are expected in a fluid environment, continuity with the civil population is disrupted. The Army is vigorously debating the current structure of civil affairs. The debate involves the civil affairs community's size, the allocation that should be in the active or reserve component, the force allocation that should belong in the general Army versus Special Operations Command, and whether civil affairs companies should establish a more formalized relationship with partnered brigade combat teams.<sup>279</sup> Furthermore, civil affairs selection, linguistic capabilities, and special-skill training must be reviewed.

### **3. Construction Engineers**

Also in great demand are construction engineers specializing in carpentry, electricity, plumbing, and other trade specialties. The current force design accounts for five, brigade-size construction engineer units in the active force to support theatre-level operations and forty-eight combat brigades. U.S. units can continue to expect combat operations in austere environments where trade skills are in high demand to improve minimum infrastructure requirements for outpost or base protection and basic life support. Much of their duties have been subsumed by contractors working in garrison and abroad; this is a pattern that should be re-examined from a cost and accessibility standpoint. More importantly, trade specialists are essential to providing emergency humanitarian support to indigenous populations. They can assist civil-military teams inspecting host-nation development projects and conduct indigenous craftsman training. Future force projections will not be limited to firepower. U.S. Army units must have the capability to provide critical services amidst conflict.

## **F. INSTITUTIONALIZING CHANGE**

Discussions and analysis of the Army's force structure often take place at the strategic policy level. Military capabilities are measured by large units and expensive equipment platforms—interchangeable cogs in the military machine. Many scholars

---

<sup>279</sup> Moore and Warmack, "Civil Affairs Transformation." Also, Boozell interview.

discuss capabilities as theoretical concepts without a nuanced understanding of ground-level operations. In an irregular environment, it is not just a question of how many troops, but what kind of troops, their training proficiencies, and the methods they employ. Planners must carefully consider the rapidly expanding number of tasks and technologies soldiers and officers are expected to master. A greater number of specialists will be necessary at every echelon to account for the diverse intelligence, security, and civil-military components of population-focused operations. According to Colonel Patton, “while attachments can fill requirements (augments from support and functional brigades), they can never replace the bonds of trust and confidence that come with organic affiliation.”<sup>280</sup> He not only recognizes a capacity shortage, but argues for specialists to be fully integrated into the tactical maneuver units they support. His argument is applicable to many traditional “non-combat” specialists that will continue to be in high demand throughout this century.

---

<sup>280</sup> Patton, “Put the ‘Police’ Back in Military Police.”

## VI. RECOMMENDATIONS

This chapter details a mosaic of capabilities that must be integrated with maneuver combat units at tactical levels for effective operations in irregular conflicts. It is a conceptual model tailored for irregular environments, but still capable of contributing to the Army's full spectrum requirement. This proposal does not counter the current "transformation" design—it adds to it. Organizational "boxes" can always be arranged to provide leaders particular capabilities to conduct essential missions. Some leaders see these boxes as interchangeable components—merely ingredients to task organize into ad hoc units. However, in irregular warfare, this combination of specialists should form a network of relationships and complementary proficiencies that are better strengthened through consistent structural integrities and collective training opportunities.

### A. OPTIMIZE FOR IRREGULAR WAR, MAINTAIN THE FLEXIBILITY

According to the current FORSCOM Commander, the one point of consensus from "Unified Quest 2007"<sup>281</sup> was that the U.S. Army will be in a "state of persistent conflict for a decade if not a generation."<sup>282</sup> The *IW JOC* acknowledges the need for the DoD force structure to be better designed to sustain a protracted irregular warfare effort. These campaigns have historically required a large number of troops. However, what is even more essential is the type of troops needed and the need to increase unit effectiveness in irregular environments on a per capita basis. This dynamic suggests a greater number of the high-yield specialties common to IW campaigns should be in the active force, and closely integrated with maneuver units at all echelons. Combined arms warfare must be expanded to include specialized capabilities that are not historically included in maneuver concepts. These capabilities should be integrated with maneuver units at battalion and company levels, optimizing most light infantry battalions for

---

<sup>281</sup> Sponsored by the Army and Joint Forces Command (JFCOM), Unified Quest is the Army's "premier wargame" to study future warfare. See <http://www.globalsecurity.org/military/library/news/2006/04/mil-060418-arnews01.htm>.

<sup>282</sup> General Charles Campbell, FORSCOM Commander, (Remarks at the Infantry Warfighting Conference, September 18, 2007, Fort Benning, GA).

irregular environments. Maintaining a sustained effort over a long duration and the importance of team integrity, begs a force structure that institutionalizes a close relationship between intelligence, combat, and civil-military specialties.

This concept is in keeping with the 2004 Defense Science Board study that recommended the Army “develop modules, below the brigade level, of S&R capabilities to facilitate task organization; and should exercise and experiment with them to determine where combinations of these capabilities can enhance U.S. effectiveness in stability operations.”<sup>283</sup> Intelligence cells, civil-military specialists such as CA and IO teams, MP units, EOD specialists, and construction engineers should be thoroughly integrated into battalion and company teams. With the exception of selected units that remain poised for strategic forced-entry and major combat operations, mobility platform distributions should become more flexible than the current light-medium-heavy and maneuver-RSTA designations allow. For example, current airborne and air assault IBCTs and SBCTs could be retained in their current design as strategic forcible-entry units, augmented from functional and multi-functional support brigades as necessary.

The remainder of the IBCTs should be converted into Security and Development Brigades, optimized for irregular warfare. Since maintaining security is still a paramount function, these units maintain small-unit close combat as a primary capability. However, compounded with proper training and leader education, they would be more capable at performing more constabulary duties such as counterinsurgency, foreign internal defense, and stability operations in a contested environment. Modular designs of transportation support and when necessary, additional firepower, can provide soldiers the mobility they need without overburdening support requirements or creating space concerns in small firebases central to their assigned population base. Closely coordinated security and civil-military operations would be conducted at the platoon, company, and battalion-level, dependent on terrain and threat, with limited resources and operational synchronization provided by brigade and higher headquarters.

---

<sup>283</sup> Defense Science Board, *2004 Summer Study, Transition to and from Hostilities* (Washington D.C.: Department of Defense, 2004), vii, [http://www.acq.osd.mil/dsb/reports/2004-12-DSB\\_SS\\_Report\\_Final.pdf](http://www.acq.osd.mil/dsb/reports/2004-12-DSB_SS_Report_Final.pdf). This study is often referred to as being the impetus for DoDD 3000.05.

Even though the functional and multi-functional modularity brigades are intended to augment the BCTs, the number of active duty civil-military specialists is marginal and accessing the reserves often proves politically untenable. If counterinsurgency and stability operations are to be protracted efforts, it does not make sense to have the assets most likely needed in these types of operations where they are unavailable. Further analysis and experimentation should consider disbanding some of the functional and multi-functional support brigades, using these capabilities to optimize modified infantry brigade combat teams for irregular conflict. Remaining functional and support brigades can “plug and play” into higher headquarters or augment heavy brigade combat teams when they are called upon to conduct stability missions. The HBCTs will continue to be the Army’s hedge against major conventional threats that may arise. In the meantime they should be carefully placed in rural and border areas, supplement light infantry with sub-brigade units of armor, and become a main effort in extremely high threat areas.

This proposal does not discount the necessity to tailor forces through operational task organizing, nor the requirement to maintain limited functional and support units—especially in highly-technical duties such as aviation, air-defense, or general support transportation and logistics functions. But, it establishes a new baseline from which to structure tactical units and reshape the Army’s force-mix from the bottom-up.

An infantry company, assigned to a security and development brigade and optimized for irregular warfare, consists of four maneuver platoons and an eight-vehicle motorized platoon. Normal attachments would consist of an MP squad specializing in investigative procedures, detainee handling, and biometric technologies; a mobility squad with EOD and demolition specialists; and a military dog team. Construction engineers would be available from the battalion’s construction and assessment platoon. The company headquarters would be expanded to include an intelligence section, civil affairs specialists, and an information operations (to include PSYOP and public affairs) team. Majors or qualified senior captains would have to lead this expanded company. See Figure 20 for an illustration of this design.

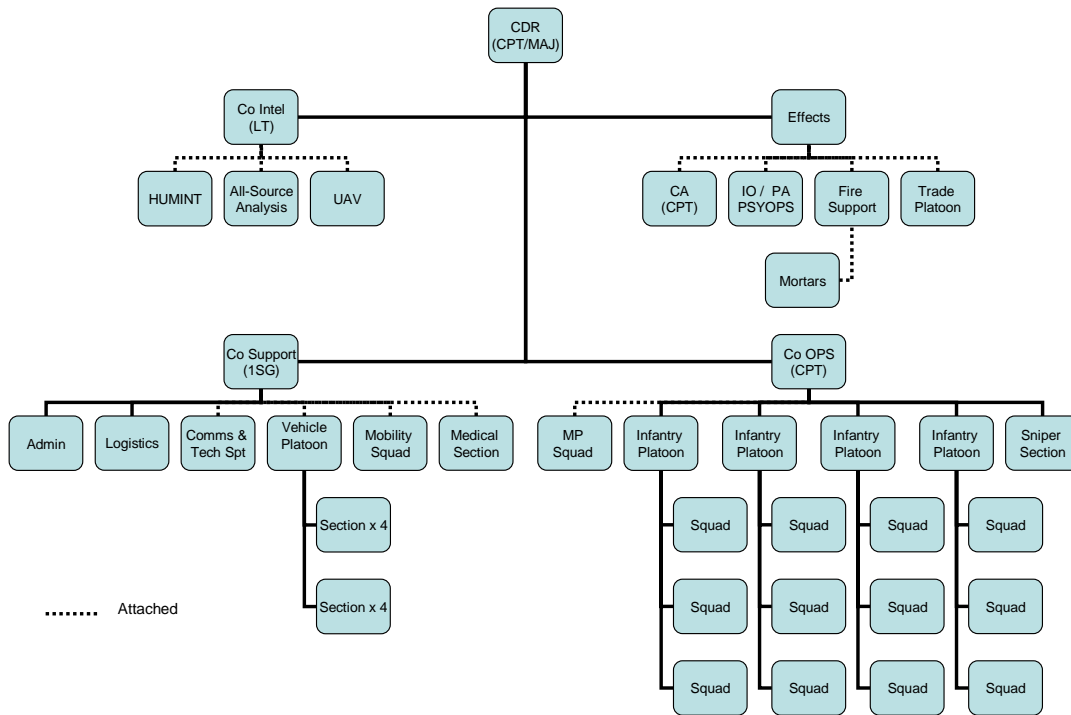

Figure 20. Infantry Company Optimized for Irregular Environments

An infantry battalion, optimized for irregular warfare in a security and development brigade has three infantry battalions, a reconnaissance company instead of a squadron, a main gun platoon, and a transport company consisting of armored vehicles with dedicated drivers and gunners. The staff has significantly increased intelligence capacities, information and public affairs staff, and dedicated civil affairs. The battalion would have an organic MP platoon to include a dedicated number of women. The battalion would also have a construction and assessment platoon led by a civil engineer. In lieu of a traditional combat engineer platoon, the modified mobility platoon would consist of explosive ordinance disposal and demolition specialists and military dog teams. See Figure 21 for an illustration of this design.

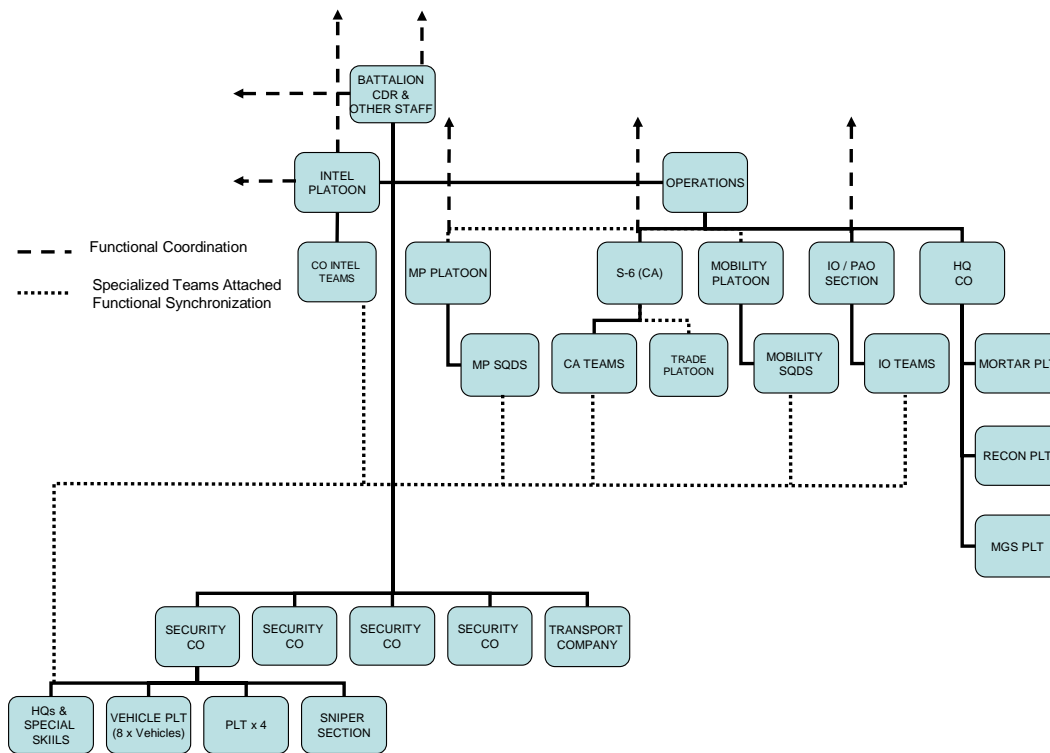

Figure 21. Infantry Battalion Optimized for Irregular Environments

The remainder of this chapter will further explain and justify these proposals. This model is designed to integrate necessary specialists at the small-unit tactical level. The Army’s force structure as a whole should be built bottom-up, using this or a similar model as a starting point. Operations in Iraq and Afghanistan and the force capability requests of geographical commanders allow for more precise operational testing and analysis.

## B. INTELLIGENCE OPERATIONS

“Conducting aggressive ISR operations and pushing intelligence collection assets and analysts to the tactical level, sometimes as far as company level, therefore benefits all echelons. It strengthens local intelligence, enhances regional and national reporting, and bolsters operations at all levels.”<sup>284</sup>

<sup>284</sup> Army, *FM 3-24, Counterinsurgency*, 3-25.

The *Army Action Plan for Stability Operations* recommends the Army develop intelligence systems “at appropriate levels” and “enhance the capability of the Army to plan, prepare, execute, and assess HUMINT operations in support of full spectrum operations.”<sup>285</sup> Trained, small units and maneuver unit leaders are some of the Army’s best collectors of raw information. But the time-consuming work of information processing and analysis should be conducted by trained specialists who work hand in hand with the collectors. Further specialization will be necessary as increased technical training is required for emerging database and digital analysis systems. These specialists should be integrated with maneuver units at every organizational level. Furthermore, continuous feedback between analysts and collectors is essential. A clear cycle of updated intelligence must be available to all echelons so that it may be consistently collaborated or refuted by all available sources.

The previous chapter argued that integration of intelligence specialists and operators must occur at lower levels within the military’s hierarchy. During irregular conflict, an extensive amount of information is collected from the bottom-up and analysis should parallel that process. *FM 3-24* states “effective operations are shaped by timely, specific, and reliable intelligence, gathered and analyzed at the lowest possible level and disseminated throughout the force.”<sup>286</sup> While every soldier may be an information collector, raw information must also be recorded, analyzed, and synthesized. This must be initially done near the point of collection where specialists have a greater understanding of the terrain and demographics of their area. The Army should continue to aggressively explore digital intelligence software systems that allow intelligence specialists assigned to the lowest-level tactical units to regularly update information and share information laterally, thereby encouraging mutual adjustments between units.

Maneuver companies should have dedicated intelligence teams with two intelligence specialists trained and capable of conducting intelligence database inputs, searches, and analysis. They should also have seasoned NCOs capable of source operations and detainee questioning. Unmanned aerial vehicle (UAV) technicians should

---

<sup>285</sup> DAMO-SSO, *Army Action Plan for Stability Operations*, 12.

<sup>286</sup> Army, *FM 3-24, Counterinsurgency*, 1-23.



also be attached for operating and maintaining designs such as the Raven or forthcoming models. Arbitrarily named the Company Intelligence Collection and Analysis Team (CAT), (see Figure 22) these specialists would ensure intelligence is effectively integrated into battalion and brigade intelligence sections and shared laterally. A former platoon leader could serve as the company intelligence officer. He would ensure the intelligence teams were properly supported by the company, and assist the commander in integrating intelligence, security, and civil-military operations.

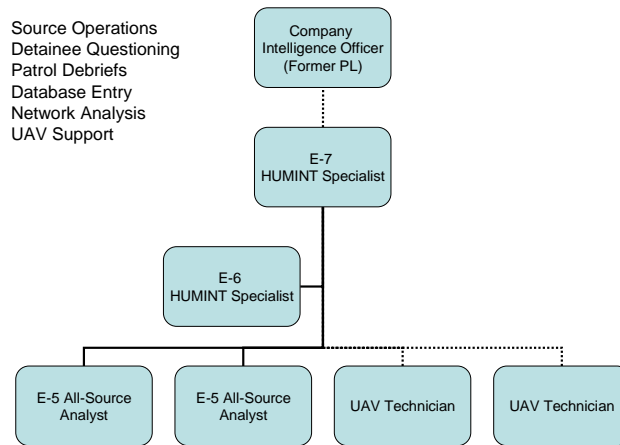

Figure 22. Company Intelligence Collection and Analysis Team (CAT)

Maneuver battalions should have an enhanced intelligence staff structured to conduct current and future operations (see Figure 23). The staff section should be led by a major, allowing the intelligence officer greater influence during the decision-making process through experience, education, and rank. He would be assisted by a senior intelligence NCO, two commissioned officers, and a warrant officer. Current operations would consist of a junior intelligence officer (or former platoon leader lieutenant), operations NCO, three radio telephone operators dual trained as analysts, a UAV section, and a human collection team dedicated to the battalion staff for detainee operations and other assigned missions. The analysis and integration section would be focused on analysis, future targeting, and integrating the battalion’s information vertically and

horizontally. The warrant officer, assisted by three all-source analysts would review company-level collection teams' information and provide top-down collection guidance as necessary.

Besides voice intercepts, tactical signal technologies have evolved into a positioning weapon allowing close integration with maneuver units to make arrests possible. These operations require close synchronization and current techniques are in keeping with *FM 3-24* which notes, "pushing SIGINT collection platforms down to tactical units can therefore improve intelligence collection."<sup>287</sup> Battalions should have a dedicated SIGINT team that would work closely with the brigade staff to conduct network analysis, collection and targeting on signals intelligence.

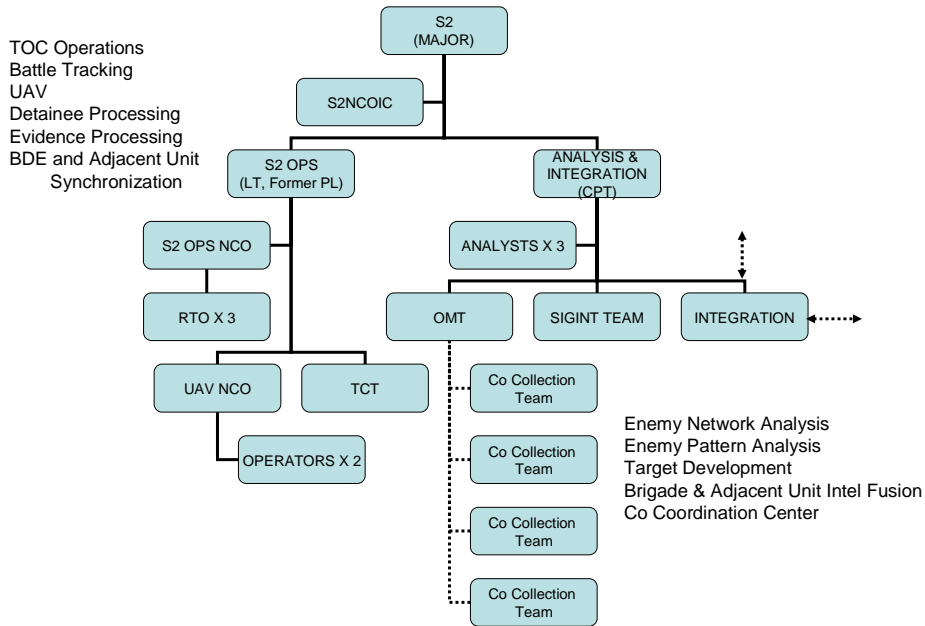

Figure 23. Battalion Intelligence Section

Brigade-level MI assets should likewise be expanded with greater HUMINT specialists that can facilitate brigades' specialized needs. In a distributed environment,

<sup>287</sup> Army, *FM 3-24, Counterinsurgency*, 3-28.

brigades should have their own DOCEX and TARGEX capabilities, limiting processing and decreasing logistics overhead for evidence transport.

The question then becomes, where will these assets come from? Some of the ten MI support brigades should be dissolved and senior intelligence staffs should be reduced, thereby pushing essential capabilities minus the duplicate command structures, to tactical units where they can be more effectively utilized. Home station individual skill training can be managed by the brigade S-2 and division G-2. Critical to this concept is for the Army to continue its recent program of recruiting older, experienced NCOs from maneuver branches for MI specialties.<sup>288</sup> There are few positions where it would be prudent for a young, inexperienced MI soldier to be conducting autonomous analysis or source operations. RTOs or drivers, jobs commonly conducted by junior analysts but not requiring a large degree of specialization, can be filled by infantrymen. Additionally, recruiting MI personnel out of the existing field provides further enlistment incentives to experience first or second-term combat soldiers.

Knowingly, further analysis and testing is required. However, the immediate necessity to increase the capacity of company and battalion intelligence capabilities should not be underestimated. Intelligence is absolutely critical to conduct precision, population-focused operations in an irregular environment. This is an area that needs the most immediate and revolutionary change within the Army's current force design.

### **C. SECURITY AND MOBILITY**

The notion that...the Army de-emphasize its strong suits (heavy units, massed firepower, high technology) in favor of stripped-down light infantry units was bound to encounter strong resistance from the Army leadership.<sup>289</sup>

---

<sup>288</sup> See, "Army Looks for NCOs to Serve as Human Intelligence Collectors," *Army News Service*, March 28, 2007, <http://www.army.mil/-news/2007/03/28/2440-army-looks-for-ncos-to-serve-as-human-intelligence-collectors>.

<sup>289</sup> Krepinevich, *The Army in Vietnam*, 36.

## **1. Vehicles**

Infantry units are best suited for most security duties in irregular environments, able to conduct extensive foot patrols and interact face to face with the populace. They are able to teach most foreign (and usually less technology-centric) armies and police forces security operations. Unfortunately, they often lack necessary vehicles for troop transport, quick reaction forces, command and control, road-blocks, and additional firepower when necessary.

Although Stryker BCTs were designed to interface those needs, it is rare that entire brigades would have to be mobile at a given time during a persistent conflict. This questions the efficacy of sustaining such large fleets. Even during forced-entry operations, Strykers are only designed to protect a toe-hold until Heavy BCTs (the force of choice for major combat operations) can arrive. Balance is necessary to make armored wheeled vehicles, such as Strykers and new variants such as the MRAP readily available to infantry units without overwhelming them with maintenance, costs, and logistics requirements. The strategic desire to maintain a small military signature in many countries of interest, and space concerns for units operating out of small fire bases or austere environments, limits the optimal number of vehicles for tactical units conducting protracted operations against an irregular threat.

More Stryker brigades is not the feasible answer. But more Stryker-like capabilities should be made available to all infantry brigade combat teams. A modular approach to support those units with adequate protected transportation and firepower is needed. Instead of light infantry being supported by limited numbers of anti-armor HMMWVs and lightly armored support vehicles such as the LMTV, they should have organic units of medium-armored, squad transportable fighting vehicles such as the Stryker or MRAP. For example, each infantry maneuver company should have approximately eight, medium-armored vehicles to transport half the company at a given time, while battalions maintain support platoons within the forward support companies to conduct logistics re-supply and additional troop movements. A battalions' reserve of transport vehicles should also be armored combat vehicles.

Similarly, the role of reconnaissance units should be re-examined. Battalion motorized companies and brigade RSTA battalions are the remnants of legacy designs suited for linear battlefields. Imagery, manned and unmanned overhead surveillance, signals intelligence, and human collection has filled the role these units were designed to perform. Joint fires, artillery smart munitions, and man-portable anti-tank weapons are quickly replacing the requirements for vehicle-mounted, direct-fire anti-tank weapons. Instead, vehicles are better utilized in an irregular, non-linear fight as modular transportation, gun, and surveillance capabilities available to all infantry battalions. Reducing the size of reconnaissance squadrons in infantry brigades to a motorized company would free up vehicles and maintenance personnel to be redistributed throughout infantry units as described previously. As additional Stryker, MRAPs, and eventually, FCS-variant vehicles come on line, a greater number of HMMWVs can be replaced.

## **2. Military Police**

Pushing HUMINT or law enforcement personnel to the battalion level and below can improve TAREX and DOCEX by tactical units...units must be able to receive intelligence collected from the documents, equipment, and personnel they capture in enough time to exploit it.<sup>290</sup>

The availability of military police should be expanded and further integrated into brigade combat teams beyond today's platoon and chance attachments. In doing so, the police must have skill sets other than common patrolling, weapons handling, and raiding techniques familiar to any infantryman. They should hone their law enforcement and evidence collection capabilities and be suited to teach station administration procedures. Trained in detainee operations, MPs can ensure prisoners are properly handled and processed. MPs should also develop technical skills in evidence collection and site exploitation to ensure detainee packets and evidence are well-documented and verified.

The *Army Action Plan* recommends the Army “develop required capabilities to provide integrated biometric collection and reporting capability at the small unit level

---

<sup>290</sup> Army, *FM 3-24, Counterinsurgency*, 3-29.

within units conducting PIO (Police Intelligence Operations) and security operations, biometric data analysis, fusion and dissemination.”<sup>291</sup> Biometric technologies need rapid fielding to assist in identifying repeat criminals and to track insurgents, despite frequent ID and passport changes and construction of databases of human networks. As biometric capabilities become more prevalent on the battlefield, MPs should become the technical specialists of choice, working closely with the intelligence sections for biometric collection, data-entry, and investigative support. MPs should no longer be trained as pseudo-SWAT teams or explicitly reserved for rear-area security details. Furthermore, females assigned to military police units are nicely suited to interact with local females, particularly in traditional societies. Non-linear operations in Afghanistan and Iraq have rapidly expanded the role of woman in irregular conflict. Establishing quotas to deliberately man MP and intelligence units with a specified number of females should be considered.

Two companies of military police should be allocated to infantry brigade combat teams. They would be led by the brigade MP, who should be a major. One company, the MP battalion support company, would allocate platoons to maneuver battalions while the MP brigade support companies would remain under the discretion of the brigade commander. The squads should be smaller, but manned with more senior MPs than currently designed. They would primarily serve as advisors and technical specialists, and less as maneuver squads (see Figure 24). The platoon leader would work closely with the battalion’s intelligence section to monitor biometric databases, conduct network analysis, and investigative police intelligence operations. The MPs would conduct prisoner and detainee handling operations and track prisoners through the prosecution system. MPs could operate as a platoon, or battalion commanders could utilize MP platoon leaders as staff propensities and detach squads to companies. MPs would augment partnered maneuver units or unilaterally embed with host-nation police when conducting advising as part of a FID effort. They should be capable of teaching and assessing community patrolling and interaction, intelligence gathering and processing, evidence gathering techniques, and assist in building judicial cases against criminals and insurgents. When

---

<sup>291</sup> DAMO-SSO, *Army Action Plan for Stability Operations*, 10.

conducting police advising, MPs should focus on stations management, investigative work, and community databases while infantrymen train weapons familiarization, arrest procedures, and community patrolling techniques. The brigade support company’s duties would be similar to today’s brigade MP platoons. They would run detention facilities, conduct guard duties, convoy security, or foreign indigenous training.

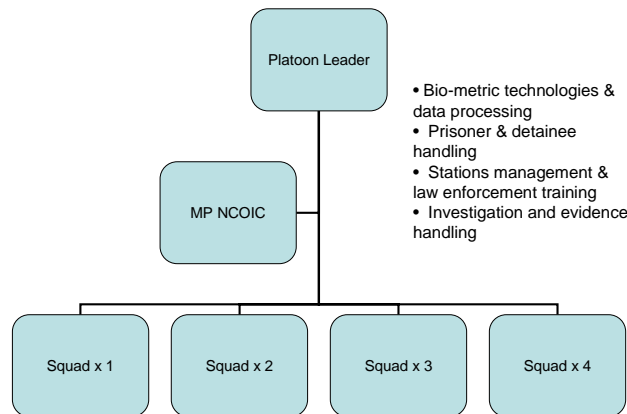

Figure 24. Battalion Military Police Platoon

### 3. Combat Engineers

Light engineers have many of the same skill sets as infantrymen, though better skilled at demolitions, obstacle development, and obstacle reduction. While adequately trained for conducting door, wall, and wire breaches, disabling improvised explosive devices such as those common to Iraq and Afghanistan is beyond their skill sets. Complex electric and mechanical explosive devices will be the continued tool of U.S. enemies. Combat engineers are generalists whose organization mirrors that of infantry units. They should be restructured as smaller, mobility platoons composed of highly—technical demolitions experts. The mobility platoon envisioned would have EOD technicians able to reduce improvised explosives in a timely fashion and serve as technical specialists to assist and supervise in the construction of explosive breach materials (see Figure 25). The execution of obstacle breaches can be performed by infantrymen. At home station, demolition specialists should attend extensive school

programs (both military and civilian law enforcement) for technical expertise and report to functional units to sustain their training abilities.

Additionally, specially-trained military working dogs have proven extremely useful in clearing buildings and sensing explosive materials.<sup>292</sup> Working dogs are in high demand in Iraq and Afghanistan. Improvised explosive devices are being used increasingly more often in Iraq to target dismounted foot patrols and soldiers entering buildings. The capacity of working dogs should be rapidly expanded. Some units already use dog teams to detect explosive materials and are experimenting with dogs as an initial entry alternative to soldiers during raids. Traditionally reserved for military police, explosive-sniffing dogs may be better associated with ordinance specialists in the proposed mobility teams and platoons.

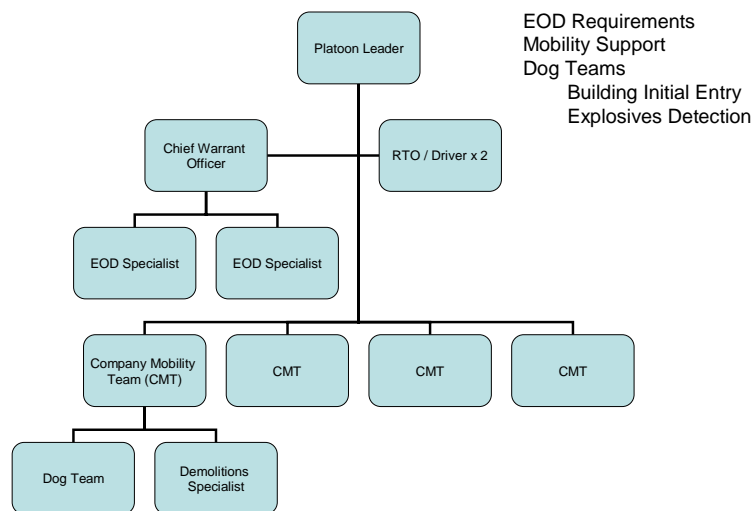

Figure 25. Battalion Mobility Platoon

The engineers also perform counter-mobility tasks that entail extensive force protection plans to support company outpost, or neighborhood defense. In some cases, despite little formal training, combat engineers have been looked to as construction

<sup>292</sup> A Special Operations officer who wished to remain anonymous, described his unit's extensive use of military dog-teams in Iraq and Afghanistan during patrols and house raids. He believed the dogs offer viable alternatives to initial entry soldiers confirming or denying the presence of explosives and enemy personnel. (Interview with the author, May 5, 2007).



project managers. Like many soldiers, combat engineers have tried to adapt to their current operating environment despite training inadequacies. Later in this section the role of civil and construction engineers will be explored. As it currently stands, combat engineers are generalists whose capabilities straddle the fence between infantrymen, EOD technicians, and civil engineers. Greater specialization is necessary.

#### **4. Advising Foreign Security Forces**

Security and development brigades, modified for irregular warfare as suggested in this paper can offer stand-alone packages for multinational exercises and extended training opportunities during steady-state operations. During stability operations, nested partnerships would allow enhanced companies with organic specialists to more effectively embed with foreign units.

Other steps could better prepare selected general purpose force leaders and units for foreign force training. Nagl's proposal for a Combat Advisor Course<sup>293</sup> should be pursued and efforts to expand individual language and foreign immersion programs for the U.S. Army should be accelerated. These skill certifications could be tagged as special skill identifiers on officer and enlisted personnel records to allow the military better tailoring when requirements for individual advising arise beyond the capacity, or capability of Special Forces units. Metz and Hoffman suggest grouping the Marine Corps and Army's brigade combat teams regionally, allowing language, geography, and cultural continuity within its units.<sup>294</sup> This may be unnecessary for heavy brigade combat teams, but could be applied to the conceptual security and development brigade's during steady-state operations.

When necessary, units can be specially designed with individuals drawn from "advisor course" graduates who have the required technical or tactical skill sets for the specific job at hand. Otherwise, an increase in age, rank, and experience for security and

---

<sup>293</sup> Nagl, John A. "Institutionalizing Adaptation: It's Time for a Permanent Army Advisor Corps."

<sup>294</sup> Metz and Hoffman, "Restructuring America's Ground Forces: Better, Not Bigger," 13. This proposal does not prevent forces from being utilized outside their regional alignments during major conflict.

development brigade company commanders, complemented by specialists in fields such as intelligence, engineering, and communications offers a suitable training team for large indigenous units. Similarly, bi-lateral and multi-national partnerships can be facilitated at other levels as well. Companies and battalions, consisting of experienced leaders, certified through a comprehensive “Advisor Course,” and supported with specialized soldiers, would be successful at operating independent of higher headquarters for distributed FID missions.

In addition to increases in intelligence capacities, this section proposed numerous changes to enhance the combat-related capabilities of infantry brigade combat teams conducting irregular warfare activities, particularly in a persistent urban environment (see Figure 26). The modified infantry brigades (security and development brigades) would increase the number of infantry battalions while reducing reconnaissance squadrons to a company-sized troop. Modular units of medium-armored wheeled vehicles would be assigned to battalions and companies for rapid troop movements and support to dismounted patrols in contested areas. However, the number of vehicles should remain small enough to minimize unit impacts on populated areas, resource requirements, costs, and space concerns. As the technology matures, main-gun system Stryker variants (MGS), FCS models, or armor attachments should be dedicated to infantry battalions as a platoon-sized reaction force. The capacity of military police in brigades would be increased to two companies. One would provide general support, while the would attach dedicated platoons to infantry battalions. Next, this chapter explores the necessary capabilities and minimum capacities for civil-military operations.

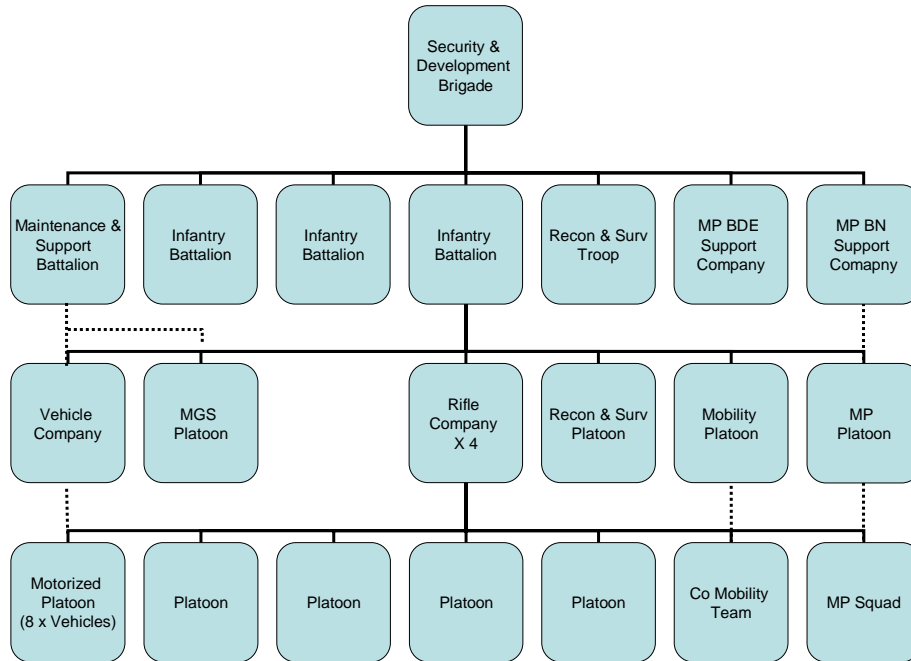

Figure 26. Combat Capabilities for the Security and Development Brigades<sup>295</sup>

## D. CIVIL-MILITARY OPERATIONS

### 1. Information Operations

In order to execute timely and relevant information operations, maneuver battalions should have an attached section of trained specialists who plan, execute, and advise battalion leadership on information operations, psychological operations, and public affairs. At a minimum, an information operations/ public affairs officer, senior NCO, two production specialists and a video technician could provide this support (see Figure 27). Production specialists would design leaflets, posters, and other written products to be produced by the brigade staff. Brigades should have production equipment, cutting down on the time and logistics required for producing and shipping

<sup>295</sup> This diagram only reflects changes as discussed in this section. It does not account for other capabilities already existing within the IBCT that haven't been discussed such as artillery, mortars, medical units etc.

products from theatre staffs. Dedicated video technicians can catalog video recordings from the companies to be used on internet and television mediums to preempt or counter insurgent propaganda.<sup>296</sup>

Companies should have an attached IO team consisting of a mid-level NCO and assistant similar to tactical PSYOPs teams. The team would advise the company commander and platoon leaders on information campaigns, synchronize efforts with the battalion staff, and conduct tactical voice broadcasts. Additionally, these specialists would assist in polling and analysis to properly target messages and determine proper dissemination techniques. Like intelligence gathering, information operations is not meant to be constrained to a handful of specialists, it must be integral to every soldiers' actions and conversations. Yet, trained specialists can work with maneuver leaders to construct and disseminate effective IO campaigns that are consistent with higher themes, but tailored to address local concerns.

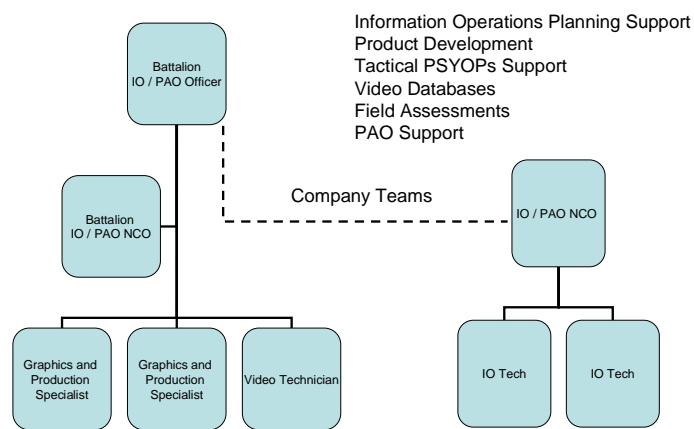

Figure 27. Battalion Information Operations Sections and Company IO Teams

<sup>296</sup> Lt. Gen. Chiarelli provides a vignette from 2006 when a combined U.S.-Iraqi SOF raid killed 17 insurgents. However, after security forces departed, the enemy moved the bodies and staged the scene to look as though security forces had executed the insurgents. Increased PAO capacities in tactical units can insure operations such as this are filmed and quickly broadcast to preempt insurgent misinformation campaigns. Chiarelli and Smith, “Learning from our Modern Wars,” 10.

## **2. Civil Affairs**

Civil Affairs teams should establish a formal partnership with maneuver units and be participants in regular collective training. Civil affairs specialists should be subject matter experts in contract proposals, civil development, economic growth, and governance capacity-building. According to Chewing and Ollivant, “civil affairs soldiers should be attached to the maneuver commander, acting more as staff proponents and subject-matter experts than as primary actors.”<sup>297</sup> Most of the maneuver commanders interviewed described the CAT-A teams as limited by the strength of one individual. The team leader conducted project site visits, met with local community members, and worked government and economic development issues. In some cases, the other team members simply served as a driver, gunner, and assistant for the team leader. Instead of autonomous teams, CA specialists should serve as integrated advisors to maneuver leaders and their staffs. As needed, they can be used as senior pay agents, project managers, and NGO intermediaries serving as the administrative headquarters and quality control for contracts with local entrepreneurs. Battalion CA members should act as liaisons between the brigade’s CMOC, B-Team, and inter-agency representatives. Companies should have civil affairs specialists serving as CMOC liaisons, advisors to the company commander, and project managers. The CA officer should also be able to assess and advise local governing bodies.

## **3. Construction Engineers**

Construction engineer unit capacities need to be increased, and their capabilities expanded. Civil and heavy engineers who are able to support force protection and civil affairs initiatives are in high demand. The future environment suggests a growing demand for engineers, both mobility and construction, and a need for greater technical specialization.

Instead of constructing and breaching wire obstacles, combat engineers need to become increasingly more specialized in a greater number of technical skills to include

---

<sup>297</sup> Chewing and Ollivant, “Rethinking Conventional Forces in COIN,” 57.

construction specialties and civil engineering. The Navy SEABEES provide an exceptional model for these skills. Naval Mobile Construction Battalions (NMCB) are one type of SEABEE unit. They consist of seven occupational specialties assigned to one of three companies in a construction battalion. NMCBs provide standard concrete, masonry, steel, and wood construction as well as specialized tasks such as water well drilling. The equipment group is composed of heavy equipment operators and mechanics. The utilities group contains utility specialists such as plumbers and construction electricians. The structural group has steelworkers, engineering aides, and builders.<sup>298</sup> Many of the officers are civil engineers with contract and project supervision tasks. When they're not deployed, the construction battalions are utilized by base public-works departments.

While the scale of work supervised or conducted by Army combat units should be kept to a necessary minimum (instead encouraging local host-nation development), a company of construction and utility specialists per brigade would greatly benefit Army operations. When necessary, construction companies could provide emergency services directly to indigenous populations. To further host-nation development, they could offer limited vocational training and supervise foreign civil projects. Each brigade would have an increased self-sustainment capacity with dedicated construction and utility engineers. Like other specialized capabilities, construction companies could report to larger functional battalions and brigades for home-station technical training. While deployed, mixed-trade platoons could be tasked to infantry battalions as needed.

#### **E. FURTHER PROFESSIONALIZE THE FORCE**

The evolutionary changes that have been posed herein are not, for the most part, based on technological solutions. They are human-capital intensive investments in the current force structure. The Army needs to transform its skill sets and organizational forms with the same effort it is investing in future weapon systems, vehicles, and hardware. Expanding the capacity of numerous "non-combat" related specialties and

---

<sup>298</sup> Lieutenant (USN) Justin Perry, civil engineer, (interview with author, October 15, 2007). See also, <https://www.seabee.navy.mil/index.cfm/4135> for further information.

increasingly integrating multiple dimensions of military expertise at lower levels within the military hierarchy will help units conducting sensitive, population-focused military operations become more effective. However, increasing job positions and changing organizational structures is not enough. Many of these specialties, such as IO, CA, MP, and engineers, must make significant capability adjustments (through profound changes in their training and educational curriculums) to ensure the right skill sets are materializing within the Army.

Irregular conflicts demand a higher caliber of leader at every level. The combined arms fight is rapidly expanding to include specialists and units beyond combat arms. Management challenges increase with larger and more diversified units as proposed in this paper. Meanwhile, the age and years of experience for most company commanders is decreasing due to accelerated promotion timelines, fast command turnovers, and post-command staffing requirements. A careful examination of the Army's promotion system is beyond the scope of this paper. However, anecdotal evidence suggests that more education, training, and preparation are needed by many company-level leaders to truly excel in the contemporary battlefield. This takes time, perhaps the most difficult resource to generate.

To manage the diverse capabilities and increased capacity of specialists advanced in this paper, infantry companies should be led by a senior captain (O-3), or junior major (O-4). They would be assisted by a captain (O-3) operations-executive officer and potentially, former platoon leaders as intelligence or effects planners (refer back to Figure 21). Battalion and brigade operations and executive officers would then be selected from among post-company command majors.<sup>299</sup> Captains would have more time for graduate education, language schools, and senior staff experiences to broaden their understanding of tactical, operational, and strategic operations. Captains could continue to command garrison companies such as recruiting and training companies where they would further prepare themselves for combat unit tours. They could also fill many of the staff positions currently manned by majors.

---

<sup>299</sup> This promotion structure would be similar to U.S. Army Special Forces where O-4s command companies and then serve as battalion and group staff officers.

Expanded opportunities for education, non-operational time and delaying the coveted company command position may encourage junior officers to stay in longer. An incremental retirement package beginning prior to the current twenty-year mark could provide a financial benefit to those who would otherwise separate. Increasing the number of platoons in a company, companies in a battalion, and battalions in a brigade as proposed, would flatten the command structure and reduce the number of headquarters, thereby reducing requirements for captains and majors on senior command staffs.

Defense planners could take personnel and organizational change one step further by cutting an entire layer of hierarchy out of the Army's force design. This would be truly transformational. Macgregor proposed the idea of decentralizing the Army's force design and making it more flexible through the creation of combat groups.<sup>300</sup> He reduced the brigade and division headquarters to one level of command. Groups (which could be designated as regiments) would consist of six to eight maneuver battalions (twice the size of today's brigades), led by a general officer and larger staff. The Groups would in turn, report to a corps-based Joint Task Force. In addition to greater flexibility in an increasingly dynamic environment, colonels (O-6) would be able to broaden their understanding of national security by serving in inter-agency and foreign military positions, seeking greater educational experiences, and further enhancing their knowledge of economic systems, governance, and strategic communications prior to assuming command of a combat group.

A further decentralized command structure, led by more experienced officers, would provide the tactical flexibility necessary in complex and politically sensitive conflicts. There are solutions to meeting the manning requirements of today, and those suggested by this proposal. The question is how much the Army is willing to part from its legacy personnel and promotion requirements to ensure combat units have the manpower they need.

Combined-arms concepts must progress beyond traditional maneuver and firepower assessments. By increasing the dedicated capacity of intelligence personnel,

---

<sup>300</sup> Macgregor, 69-86.



mobility assets, and population-focused capabilities in infantry units, the Army will be better suited for irregular warfare. Having these specialists organic to the units would promote greater effectiveness than the adhocacy generated by the current brigade modular design.

THIS PAGE INTENTIONALLY LEFT BLANK

## VII. CONCLUSION

The United States, a military and economic hegemonic power, has been humbled by low-tech guerrilla fighters in Afghanistan and Iraq. Future conflicts will likely include similar types of enemies, socio-economic variables, and political conditions. In the muddied waters of stability operations and counterinsurgency, face-to-face interaction with the population is necessary. Information and situational awareness is gained from the bottom up, and more rapid and lateral communications are necessary. Flexible, agile forces, decentralized and dispersed throughout an area for extended periods of time, are essential. Military efforts should be focused on securing the population, developing indigenous security forces, promoting economic growth, and assisting in the development of viable political systems. Acknowledging security as paramount, firepower should be used sparingly, while intelligence, information operations, and civil affairs should be employed exceedingly more. The Army's force structure should reflect this paradigm shift.

Despite rhetoric to the contrary, the Army's current organizational structure is optimized for combined arms maneuver warfare against conventional enemies. Its current hierarchy stems from the Napoleonic Era, and its organizational design has remained relatively unchanged since the U.S. prepared for war with the Soviet Union throughout the latter half of the twentieth century.<sup>301</sup> Firepower and mobility have been the hallmarks of warfare, embraced by the Army and exemplified in the helicopter attacks and tank battles of Operation Desert Storm.

Since the majority of military operations are executed at the lowest levels of command (while following operational and strategic guidance), alternative models for

---

<sup>301</sup> Wilson, *Bureaucracy*, Chapter 12, outlines four major changes the Army has made to its war-fighting doctrine and structures since WWII: traditional structure; "pentomic" division; Reorganization Objectives Army Division (ROAD); Active Defense; and AirLand Battle. While the Army saw each of these initiatives as major reorganizations, Wilson notes that "at a deeper level, very little changed...the army limited its innovations to thinking about better ways to counter a Soviet invasion of Western Europe." While the battlefield scenario changed from Europe to Asia in the 1990s, the assumptions regarding future enemy tactics were still predominately conventional in nature. As argued earlier in this paper, brigade modular organizations (the latest organizational change), and its strategic underpinning—expeditionary, "net-centric warfare" were no different.

force structure must consider how essential counterinsurgency and stabilization tasks can be optimally performed at those levels (platoon, company, and battalion). As shown in Chapter IV, scholars and policy makers who have proposed adaptations to the Army's force structure are lacking this level of organizational analysis and detail. Alternative organizational models need to be designed and field-tested. These models can then be evaluated in the context of irregular warfare and conventional combat operations. A new, more adaptive, full-spectrum force may emerge from the analytical testing, or further support for greater specialization may become evident. The security and development brigade concept could simply serve as a testing ground for capability increases to all brigade combat teams. Nevertheless, previous assumptions about the utility of forces designed for "rapid decisive operations" performing optimally in counterinsurgency and stabilization tasks need to be further examined.

The U.S. military can continue to expect increased participation in irregular environments. Its participation may be in a partnered capacity to limit conflict in allied weak states; as a contributing participant in multinational operations; or, as a unilateral effort when a threat is eminent and critical U.S. interests are vital. Witnessing the difficulties in Iraq and Afghanistan, there are many critics who negate the need for taking a profound look at the U.S. military's current capabilities. They do not see a capability gap, but a problematic foreign policy. One critic of the Iraq War stated: "Militaries are built to fight and win wars, not bind together failing nations."<sup>302</sup> That same mentality has survived within the institutional Army despite operations in Vietnam, Lebanon, Somalia, Kosovo, Bosnia, Afghanistan, and Iraq. The nature of warfare has changed beyond traditional classifications, and post-conflict stabilization and transitions will always be inextricably linked to warfare. Less, the U.S. continues to risk "losing the peace" and further empowers its potential adversaries. Foreign policy is fickle and Americans are often quick to forget (or misunderstand) history's lessons. Despite its track-record, the Army must be capable of succeeding in any environment should national interests (and those of her Allies) be at stake.

---

<sup>302</sup> Chuck Hagel, "Leaving Iraq, Honorably," *Washington Post*, November 26, 2006, B7.

Chapter II described the Department of Defense's strategic policies for adapting to changes in the U.S. threat environment, and summarized operating concepts for conducting irregular operations in the future. The Army states its current organizational plan, the modular brigade concept, is as poised for stability operations as it is for conventional offensive operations. However, a brief review of the Revolution in Military Affairs debate and defense transformation concepts in Chapter III demonstrated incongruence between transformation's initial concept of rapid decisive operations against a regional competitor, and today's notion of sustained, protracted warfare against irregular opponents. While the Army is making substantial headway in doctrine and training initiatives, its organizational details have remained unscathed. Chapter V outlined numerous shortfalls of the current design in the areas of intelligence, mobility, military police, information operations, civil affairs, and construction capabilities.

The Army continues to promote the maintenance of a "full spectrum" generalist force, able to conduct offensive, defensive, and stability operations. It negates any concepts of "specialized forces," dismissing the fact that the Army is already specialized to the degree that it has heavy, Stryker, light, functional, and multi-functional support brigades. Internal to brigades, battalions and companies have unique capabilities. While each type of brigade is capable of conducting full-spectrum operations across the spectrum of conflict, they are designed for particular threat environments, terrain conditions, and task specialties. Based on evidence collected from interviews, presentations from subject matter experts, archival analysis of the contemporary battlefield, historical insights, and organizational theory, this paper proposes numerous conceptual, and more detailed structural recommendations to the Army's force structure.

A majority of the SBCTs and IBCTs should be converted into security and development brigades (SDBs), optimized for stability operations in irregular environments focused on controlling (and protecting) populations, defeating guerrilla fighters, and conducting initial indigenous governance and economic capacity development. The units would still be full spectrum capable (in fact, establishing and maintaining a secure environment through offensive and defensive operations is critical),

but they would be designed with stability operations as their core task. These units would be no more “specialized,” than a heavy brigade is for conventional offensive and defensive warfare.

The security and development brigades would have three infantry battalions and a reconnaissance company instead of a squadron. As described in Chapter VI, they would be organized as follows:

- Infantry companies would be led by a major, or qualified senior captain. His headquarters would have a small, but highly-trained support team of intelligence and civil-military specialists such as all-source analysts, HUMINT collection specialists, UAV technicians, civil affairs, and information operations specialists. Instead of young, newly trained initial-entry soldiers, these specialists would be former maneuver NCOs and officers who conducted specialty skill transfers.
- Infantry companies would have an organic motorized platoon consisting of medium-weight vehicles such as the MRAP, Stryker, FCS, or other variant of armored vehicle that could be tailored to missions for troop transport and crew-served weapon employment. Additional armored combat vehicles could be resourced by the battalion’s transport company or higher-level modular units.
- The infantry battalions would have four companies, a reconnaissance platoon, and a main gun (or attached armor) platoon.
- The battalion staff would have significantly increased intelligence capacities, information operations and public affairs specialists, and dedicated civil affairs.
- Battalion capabilities would also be enhanced with an organic MP platoon, specializing in investigative procedures, detainee handling, and biometric technologies. A dedicated number of women would be included in the MP unit.
- The battalion would have a construction and assessment platoon, led by a civil engineer and composed of trade-craft specialists.
- The battalion would have a mobility platoon consisting of explosive ordinance disposal (EOD) and demolition specialists, and military dog teams.
- Mobility squads, military police squads, civil affairs, and construction engineers could be attached to companies as directed by the battalion commander.
- Non-combat specialists would belong to a functional chain of command for home-station technical training. During combat operations, this chain

of command would provide functional advising and staff support to brigade and higher echelons.

Selected Stryker brigade combat teams, Airborne, and Air Assault brigade combat teams tailored for strategic missions such as rapid deployment and forced-entry requirements could remain in their current design. The heavy brigade combat teams would continue to be America's dominant force in major conventional operations, conflict in open terrain, and as necessary, resourced to conduct urban and population-focused operations. Limited numbers of support and functional brigades would maintain stand-alone capabilities. They would provide theatre support and detach sub-brigade units to heavy brigade combat teams as necessary.

The proposed force structure would still allow security and development brigades to conduct conventional offensive and defensive operations where its small unit proficiency would be capable of defeating an adversary in a close fight, or utilizing stand-off joint air, man-portable, and indirect weapons against distant targets. These tactics are as essential to irregular operations as they are conventional ones. However, they are not sufficient to properly protect a given population, defeat or marginalize guerrilla fighters, train indigenous security forces, or promote the development and stability of an area before or after conflicts occur. Besides surge capabilities, an additional benefit of creating more autonomous, multi-functional units with higher rank, education, and experience levels is their ability to participate in steady-state multi-national partnerships and bilateral foreign internal defense operations.

Manpower required for this restructuring would be derived from "flattening" the command and control system by increasing the number of maneuver companies per battalion, battalions per brigade, and reducing the number of brigade and higher headquarters. Reconnaissance squadrons would be reduced to troop size allowing manpower and equipment to be reallocated to company vehicle platoons. Fewer brigades would be available for rotational pools, but fewer brigades would be necessary. The numbers would be negated by enhanced effectiveness on a per-capita basis.

Evidence from practitioners of counterinsurgency operations in Iraq and Afghanistan suggest that command relationships, intelligence, and specialized

capabilities within the brigade combat team are still confined to a steeply hierarchical and top-down driven organizational structure. Battalions and their subordinate maneuver units have remained largely untouched, lacking critical skill capabilities for population-focused operations. Despite the Army's proclamation of "the most comprehensive transformation of its force since World War II,"<sup>303</sup> this study challenges the notion that incremental steps taken by current modularity initiatives are bold enough to allow Army ground forces to properly prepare for, and face the future challenges of conducting irregular operations in the twenty-first century.

---

<sup>303</sup> Army Transformation Office, 2004 Army Transformation Roadmap.



## LIST OF REFERENCES

### BOOKS AND ARTICLES

- Allison, Graham and Philip Zelikow. *Essence of Decision*. New York: Addison-Wesley, 1999.
- Andrew, Brad T. "Changing the Fundamentals of Intelligence." *Military Intelligence Professional Bulletin*, January-March (2003).  
[http://www.findarticles.com/p/articles/mi\\_m0IBS/is\\_1\\_29/ai\\_97822101/print](http://www.findarticles.com/p/articles/mi_m0IBS/is_1_29/ai_97822101/print).  
(Last accessed May 2007).
- Arreguin-Toft, Ivan. *How the Weak Win Wars*. England: Cambridge University Press, 2005.
- Aylwin-Fosters, Nigel. "Changing the Army for Counterinsurgency Operations." *Military Review*, November-December (2005).
- Baker, Ralph O. "The Decisive Weapon: A Brigade Combat Team Commander's Perspective on Information Operations." *Military Review*. May-June (2006).
- Baker, Ralph O. "HUMINT-CENTRIC OPERATIONS: Developing Actionable Intelligence in the Urban Counterinsurgency Environment." *Military Review*, March-April (2007).
- Bardham, Pranab. "Decentralization of Governance and Development." *The Journal of Economic Perspectives*, vol. 16, no. 4 (Autumn 2002): 185-205.
- Barnett, Thomas. *Blueprint for Action, A Future Worth Creating*. New York: G.P. Putnam's Sons, 2005.
- Barnett, Thomas. *The Pentagon's New Map*. New York: Penguin Group, 2004.
- Binnendijk, Hans and Stuart Johnson, eds. *Transforming for Stabilization and Reconstruction Operations*. Washington D.C.: National Defense University Press, 2004.
- Bolman, Lee G. and Terrence E. Deal. *Reframing Organizations*. San Francisco: Jossey-Bass, 2003.
- Boot, Max. *The Savage Wars of Peace*. New York: Basic Books, 2002.
- Boot, Max. *War Made New: Technology, Warfare, and the Course of History, 1500 to Today*. New York: Gotham Books, 2006.

- Broemmel, Jarett, Terry L. Clark, and Shannon Nielsen. "The Surge Can Succeed." *Military Review* (July-August 2007).
- Cable, Larry. *Conflict of Myth*. New York: New York University Press, 1986.
- Cassidy, Robert. *Counterinsurgency and the Global War on Terror*. Westport: Praeger Security International, 2006.
- Cebrowski, Arthur K. and John J. Garstka. "Network-Centric Warfare: Its Origin and Future." *Proceedings*, January (1998).  
<http://www.comw.org/rma/fulltext/overview.html>. (Last accessed June 2007).
- Chiarelli, Peter W. and Patrick R. Michaelis. "Full Spectrum Operations." *Military Review* July-August (2005).
- Chiarelli, Peter W. and Stephen M. Smith. "Learning from our Modern Wars: The Imperatives of Preparing for a Dangerous Future." *Military Review*, September-October (2007).
- Cohen, Eliot, Conrad Crane, Jan Horvath, and John Nagl. "Principles, Imperatives, and Paradoxes of Counterinsurgency." *Military Review*, March-April (2006).
- CompanyCommand Team. "Leadership Challenges in Iraq." *ARMY*, September 2007.
- Dobbins, James, Seth G. Jones, Keith Crane, and Beth Cole DeGrasse. *The Beginner's Guide to Nation-Building*. Santa Monica: RAND, 2007.
- Dobbins, James, John G. McGinn, Keith Crane, Seth G. Jones, Rollie Lal, Andrew Rathmell, Rachel Swanger, and Anga Timilsina. *America's Role In Nation-Building, From Germany to Iraq*. Santa Monica: RAND, 2003.
- Donovan, David. *Once A Warrior King, Memories of an Officer in Vietnam*. New York: Ballantine Books, 1985.
- Dziedzic, Michael J. and Michael K. Seidl. "Provincial Reconstruction Teams and Military Relations with International and Nongovernmental Organizations in Afghanistan." *United States Institute of Peace Special Report*, no. 147 (September 2005).
- Ellsworth, James B. "SysAdmin: Toward Barnett's Stabilization and Reconstruction Force." *The Land Warfare Papers* vol. 57 (2006).
- English, John A. and Bruce I. Gudmundsson. *On Infantry*. Connecticut: Praeger, 1994.

- Galula, David. *Counterinsurgency Warfare Theory and Practice*. Westport: Praeger Security International, 2006.
- Gibson, Chris. "Battlefield Victories and Strategic Success: The Path Forward in Iraq." *Military Review*, September-October (2006).
- Glenn, Russell, John Gordon, Tom Herbert, John Matsumura, Randall Steeb, and Paul Steinberg. *Lightning Over Water: Sharpening America's Light Forces for Rapid Reaction Missions*. Santa Monica: RAND, 2001.
- Gwinn, Jeremy. "Organizing for Counterinsurgency at the Company and Platoon Level." *Small Wars Journal*, August 2, 2007.  
<http://www.smallwarsjournal.com/blog/2007/08/organizing-for-counterinsurgen/>.  
 (Last accessed September 2007).
- Hammes, Thomas X. "The Evolution of War: The Fourth Generation." *Marine Corps Gazette*, September 1994. <http://www.d-n-i.net/fcs/hammes.htm>. (Last accessed May 2007).
- Hammes, Thomas X. "Fourth Generation Warfare Evolves, Fifth Emerges." *Military Review* May-June (2007): 14-23.
- Hammes, Thomas X. "Insurgency: Modern Warfare Evolves into a Fourth Generation." *Strategic Forum* no. 214 (January 2005),  
<http://www.ndu.edu/inss/Strforum/SF214/SF214.pdf>. (Last accessed September 2007).
- Hammes, Thomas X. *The Sling and the Stone, On War in the 21st Century*. Minnesota: Zenith Press, 2004.
- Hasler, Jeffrey L., Chief Warrant Officer 4. "Defining War: New doctrinal definitions of irregular, conventional and unconventional warfare." *Special Warfare Journal*, March-April (2007).
- Hersey, John. *A Bell for Adano*. New York: Vintage Books, 1988.
- Hoffman, Bruce. *Insurgency and Counterinsurgency in Iraq*. Washington D.C.: RAND, June 2004.
- Hoffman, Frank and Steven Metz. "Restructuring America's Ground Forces: Better, Not Bigger." The Stanley Foundation Policy Analyst Brief, September 2007.  
[http://www.stanleyfoundation.org/publications/pab/Metz\\_HoffmanPAB07.pdf](http://www.stanleyfoundation.org/publications/pab/Metz_HoffmanPAB07.pdf).  
 (Last accessed October 2007).

- Huntington, Samuel P. "The Clash of Civilizations." *Foreign Affairs*, vol. 72, no. 3 (Summer 1993). <http://www.alamut.com/subj/economics/misc/clash.html>. (Last accessed November 2006).
- Iwicki, Stephen K. "CSA's Focus Area 16: Actionable Intelligence...one year later." *Military Intelligence Professional Bulletin*, October-December (2004). [http://findarticles.com/p/articles/mi\\_m0IBS/is\\_4\\_30/ai\\_n13822278/print](http://findarticles.com/p/articles/mi_m0IBS/is_4_30/ai_n13822278/print). (Last accessed June 2007).
- Kaplan, Robert D. "The Coming Anarchy." *The Atlantic Monthly*, February, 1994. <http://www.theatlantic.com/doc/prem/199402/anarchy>. (Last accessed May 2007).
- Komer, Robert W. *Bureaucracy Does Its Thing: Institutional Constraints on U.S.-GVN Performance in Vietnam*. Santa Monica: RAND, 1972.
- Komer, Robert W. *Bureacracy at War: U.S. Performance in the Vietnam Conflict*. Boulder: Westview Press, 1986.
- Krepinevich, Andrew Jr. *The Army and Vietnam*. Baltimore: John Hopkins University Press, 1986.
- Lansdale, Edward Geary. *In the Midst of Wars, An American's Mission to Southeast Asia*. New York: Fordham University Press, 1991.
- Liang, Qia and Wang Xiangsui. *Unrestricted Warfare*. Beijing: PLA Literature and Arts Publishing House, 1999.
- Long, Austin. *On "Other War," Lessons from Five Decades of RAND Counterinsurgency Research*. Santa Monica: RAND, 2006.
- Lundberg, Kirsten. "The Accidental Statesman: General Petraeus and the City of Mosul, Iraq." Student case study, C15-06-1834.0, Kennedy School of Government Case Program, Harvard University, 2006.
- Macgregor, Douglas A. *Breaking the Phalanx: A New Design for Landpower in the 21st Century*. Westport: Praeger, 1997.
- Magnuson, Stew. "Eyes Wide Open." *National Defense*, May 2007.
- Malcom, Ben S. *White Tigers, My Secret War in Korea*. U.S.: Brassey's, 2003.
- Manwaring, Max G. ed. *Uncomfortable Wars, Toward a New Paradigm of Low Intensity Conflict*. Boulder: Westview Press, 1991.

- McGrath, John. "Boots on the Ground: Troop Density in Contingency Operations." Global War on Terrorism Occasional Paper 16, Combat Studies Institute Press, Fort Leavenworth, Kansas, 2006.  
[http://www.cgsc.army.mil/carl/download/csipubs/mcgrath\\_boots.pdf](http://www.cgsc.army.mil/carl/download/csipubs/mcgrath_boots.pdf). (Last accessed September 2007).
- McMaster, H.R. "A Crack in the Foundation: Defense Transformation and the Underlying Assumption of Dominant Knowledge in Future War." Student issue paper, CSL, U.S. Army War College, vol. S03-03, November 2003.
- McNab, Robert M. and Edward Mason. "Reconstruction, the Long-Tail, and Decentralization." Defense Resource Management Institute working paper, October 2006.
- Mintzberg, Henry. *The Structuring of Organizations*. New Jersey: Prentice Hall, 1979.
- Moghaddam, Fathali M. "The Staircase to Terrorism, A Psychological Exploration." *American Psychologist*, vol. 60, no. 2 (February-March 2005).
- Murray, Williamson. *War and Urban Terrain in the Twenty-First Century*. Alexandria: Institute for Defense Analyses, 2001.
- Nagl, John A. "Institutionalizing Adaptation: It's Time for a Permanent Army Advisor Corps." Center for a New American Security paper, June 2007.  
[http://www.newamericansecurity.org/publications/Nagl\\_AdvisoryCorp\\_June07.pdf](http://www.newamericansecurity.org/publications/Nagl_AdvisoryCorp_June07.pdf). (Last accessed July 2007).
- Nagl, John A. *Learning to Eat Soup With a Knife, Counterinsurgency Lessons from Malaya and Vietnam*. Chicago: University of Chicago Press, 2005.
- Ollivant, Douglas and Eric Chewning. "Rethinking Conventional Forces in COIN Operations." *Military Review*, July-August (2006).
- Patton, David L. "Put the 'Police' Back in Military Police." *ARMY Magazine*, September 2007.
- "Pentagon Requests Additional MRAP Funds." *ARMY Magazine*, September 2007.
- Perito, Robert M. "Provincial Reconstruction Teams in Iraq." *United States Institute of Peace Special Report*, no. 185 (March 2007).
- Quinlivan, James T. "Burden of Victory, The Painful Arithmetic of Stability Operations." *RAND Review* (Summer, 2003).  
<http://www.rand.org/publications/randreview/issues/summer2003/burden.html>. (Last accessed June 2007).

- Record, Jeffrey. "The American Way of War, Cultural Barriers to Successful Counterinsurgency." Cato Institute paper, no. 577, September 1, 2006. <http://www.cato.org/pubs/pas/pa577.pdf>. (Last accessed May 2007).
- Sageman, Marc. *Understanding Terror Networks*. Philadelphia: University of Pennsylvania Press, 2004.
- Sepp, Kalev I. "Best Practices in Counterinsurgency." *Military Review*, May-June (2005).
- Steele, Dennis. "The Army Magazine Hooah Guide to Army Transformation." *ARMY Magazine*, 2001. [http://www.ousa.org/PDFdocs/Hooah\\_Guide\\_web.pdf](http://www.ousa.org/PDFdocs/Hooah_Guide_web.pdf). (Last accessed May 2007).
- Steele, Dennis. "Realizing the Army Vision." *ARMY Magazine*, December 2002. [http://findarticles.com/p/articles/mi\\_qa3723/is\\_200212/ai\\_n9156918/print](http://findarticles.com/p/articles/mi_qa3723/is_200212/ai_n9156918/print). (Last accessed May 2007).
- Tucker, David and Christopher J. Lamb. "Restructuring Special Operations Forces for Emerging Threats." *Strategic Forum* no. 219 (January 2006).
- Van Creveld, Martin. *Command in War*. Cambridge: Harvard University Press, 1985.
- Van Creveld, Martin. *The Transformation of War: The Most Radical Reinterpretation of Armed Conflict Since Clausewitz*. New York: The Free Press, 1991.
- Vick, Alan, David Orletsky, Bruce Pirnie, Seth Jones. *The Stryker Brigade Combat Team, Rethinking Strategic Responsiveness and Assessing Deployment Options*. Santa Monica: RAND, 2002.
- Watson, Brian G. *Reshaping the Expeditionary Army to Win Decisively: The Case for Greater Stabilization Capacity in the Modular Force*. Carlisle: Strategic Studies Institute, August 2005.
- Weigley, Russell F. *The American Way of War*. New York: Macmillan, 1973.
- Weimann, Gabriel. *Terror on the Internet, The New Arena, the New Challenges*. Washington D.C.: United States Institute of Peace Press, 2006.
- West, Bing. "Rediscovering the Infantry in a Time of Transformation," *Defense Horizons*, no. 10 (March 2002).
- West, Bing. *The Village*. New York: Pocket Books, 2003.
- Wilson, James. *Bureaucracy*. U.S.: Basic Books, 1989.

## U.S. GOVERNMENT SOURCES

- Commission on Roles and Missions of the Armed Forces, John P. White, Chairman.  
*Directions for Defense, The Department of Defense Report.* Washington D.C.:  
Brassey's, 1995.
- Department of the Army. *Field Manual 1-02, Operational Terms and Symbols.*  
Washington D.C.: Government Printing Office, 2004.
- Department of the Army. *Field Manual 3-0, Operations.* Washington D.C.:  
Government Printing Office, 2001. (Updated release pending).
- Department of the Army. *Field Manual 3-24, Counterinsurgency.* Washington D.C.:  
Government Printing Office, 2006.
- Department of the Army. *Field Manual 3-90.6, The Brigade Combat Team.* Washington  
D.C.: Government Printing Office, 2006.
- Department of the Army. *Field Manual 31-20-3, Foreign Internal Defense Tactics,  
Techniques, and Procedures for Special Forces.* Washington D.C.: Government  
Printing Office, 1994.
- Department of the Army. *Field Manual 3-21.31, Stryker Brigade Combat Team.*  
Washington D.C.: Government Printing Office, 2003.
- Department of the Army, G-3/5/7, Strategy, Plans, and Policy Directorate, Stability  
Operations Division (DAMO-SSO). *Army Action Plan for Stability Operations,  
Army Campaign Plan Decision Point 105.* Washington D.C.: Department of the  
Army, 2 August, 2007.
- Defense Science Board. *2004 Summer Study, Transition to and from Hostilities.*  
Washington D.C.: Department of Defense, 2004.  
[http://www.acq.osd.mil/dsb/reports/2004-12-DSB\\_SS\\_Report\\_Final.pdf](http://www.acq.osd.mil/dsb/reports/2004-12-DSB_SS_Report_Final.pdf).  
(Last accessed April 2007).
- Department of Defense. *Joint Publication 1-02, Department of Defense Dictionary of  
Military and Associated Terms.* Washington D.C.: Government Printing Office,  
2001. [http://www.dtic.mil/doctrine/jel/new\\_pubs/jp1\\_02.pdf](http://www.dtic.mil/doctrine/jel/new_pubs/jp1_02.pdf). (Last accessed  
May 2007).
- Director, Force Transformation, Office of the Secretary of Defense. *Military  
Transformation, A Strategic Approach.* Washington D.C.: Department of  
Defense, Fall 2003.  
[http://www.of.t.osd.mil/library/library\\_files/document\\_297\\_MT\\_StrategyDoc1.pdf](http://www.of.t.osd.mil/library/library_files/document_297_MT_StrategyDoc1.pdf)  
f. (Last accessed May 2007).

- England, Gordon. "Military Support for Stability, Security, Transition, and Reconstruction (SSTR) Operations." *Department of Defense Directive 3000.05*, November 28, 2005. <http://www.dtic.mil/whs/directives/corres/pdf/300005p.pdf>. (Last accessed April 2007).
- Feickert, Andrew. *U.S. Army's Modular Redesign: Issues for Congress, RL32476*. Washington D.C.: Congressional Research Service, updated May 5, 2006. <http://fpc.state.gov/documents/organization/67816.pdf>. (Last accessed May 2007).
- The Office of the Chairman of the Joint Chiefs of Staff. *Capstone Concept for Joint Operations, v 2.0*. Washington D.C.: Department of Defense, August, 2005. [http://www.dtic.mil/futurejointwarfare/concepts/approved\\_ccjov2.pdf](http://www.dtic.mil/futurejointwarfare/concepts/approved_ccjov2.pdf). (Last accessed May 2007).
- The Office of the Deputy Chief of Staff, U.S. Army Operations, Army Transformation Office. *2004 Army Transformation Roadmap*. Washington D.C.: Department of Defense, July, 2004. [http://www.oft.osd.mil/library/library\\_files/document\\_386\\_ATR\\_2004\\_Final.pdf](http://www.oft.osd.mil/library/library_files/document_386_ATR_2004_Final.pdf). (Last accessed November 2006).
- The Office of the President of the United States of America. *The National Security Strategy of the United States of America*. Washington D.C.: March, 2006. <http://www.whitehouse.gov/nsc/nss/2006/nss2006.pdf>. (Last accessed February 2007).
- The Office of the Secretary of Defense. *The National Defense Strategy of the United States of America*. Washington D.C.: Department of Defense, March, 2005. [http://www.globalsecurity.org/military/library/policy/dod/nds-usa\\_mar2005.htm](http://www.globalsecurity.org/military/library/policy/dod/nds-usa_mar2005.htm). (Last accessed February 2007).
- The Office of the Secretary of Defense. *Quadrennial Defense Review Report*. Washington D.C.: Department of Defense, September 30, 2001. <http://www.defenselink.mil/pubs/pdfs/qdr2001.pdf>. (Last accessed May 2007).
- The Office of the Secretary of Defense. *Quadrennial Defense Review Report*. Washington D.C.: Department of Defense, February 6, 2006. <http://www.defenselink.mil/qdr/report/Report20060203.pdf>. (Last accessed May 2007).
- The Office of the Secretary of Defense. *Transformation Planning Guidance*. Washington D.C.: Department of Defense, April 2003. [http://www.oft.osd.mil/library/library\\_files/document\\_129\\_Transformation\\_Planning\\_Guidance\\_April\\_2003\\_1.pdf](http://www.oft.osd.mil/library/library_files/document_129_Transformation_Planning_Guidance_April_2003_1.pdf). (Last accessed November 2006).



The Office of the Special Inspector General for Iraq Reconstruction. "Erbil Maternity and Pediatric Hospital, Erbil, Iraq, Sustainment Assessment." Report no. SIGIR PA-06-094, April 19, 2007. [http://www.sigir.mil/reports/pdf/assessments/PA-06-094\\_Erbil\\_Hospital.pdf](http://www.sigir.mil/reports/pdf/assessments/PA-06-094_Erbil_Hospital.pdf). (Last accessed May 2007).

Serafino, Nina M. *Peacekeeping and Related Stability Operations: Proposals for Army Force Structure Changes RS22473*. Washington D.C.: Congressional Research Service, July 2006. (Last accessed May 2007).

Task Force Modularity. *Army Comprehensive Guide to Modularity, vol. 1, ver. 1.0*. Fort Monroe, VA: TRADOC, October, 2004. [http://www.forscom.army.mil/weathr/Army\\_Transformation/Mod\\_OO\\_v.\\_1.0.pdf](http://www.forscom.army.mil/weathr/Army_Transformation/Mod_OO_v._1.0.pdf) (Last accessed April 2007).

U.S. Joint Forces Command. *Joint Urban Operations Joint Integrating Concept, Version 1.0*. Washington D.C.: Department of Defense, July 2007. [http://www.dtic.mil/futurejointwarfare/concepts/juo\\_jic\\_v1.pdf](http://www.dtic.mil/futurejointwarfare/concepts/juo_jic_v1.pdf). (Last accessed September 2007).

U.S. Joint Forces Command. *Military Support to Stabilization, Security, Transition, and Reconstruction Operations Joint Operating Concept, Version 2.0*. Washington D.C.: Department of Defense, December 2006. [http://www.dtic.mil/futurejointwarfare/concepts/sstro\\_joc\\_v20.doc](http://www.dtic.mil/futurejointwarfare/concepts/sstro_joc_v20.doc). (Last accessed July 2007).

U.S. Joint Forces Command, Joint Warfighting Center. *Irregular Warfare Special Study*. Washington D.C.: Department of Defense, August 2006. <http://merln.ndu.edu/archive/DigitalCollections/IrregWarfareSpecialStudy.pdf>. (Last accessed July 2007).

U.S. Special Operations Command and Marine Corps Combat Development Command. *Irregular Warfare Joint Operating Concept, Version 1.0*. Washington D.C.: Department of Defense, September 2007. <http://www.fas.org/irp/doddir/dod/iw-joc.pdf>. (Last accessed September 2007).

## **PRESENTATIONS AND BRIEFINGS**

Barry, Charles, Center for Technology and National Security Policy. "Organizing Land Forces for Stability Operations." PowerPoint presentation given at the National Defense University and CTNSP Short Course entitled, "Force Structure for Stability Operations and Interagency Integration," Fort McNair, Washington D.C., May 23, 2007. Available on CD.

- Boot, Max. "Military Strategies for Unconventional Warfare." Comments at the Council on Foreign Relations, hosted by Thomas D. Shanker, October 27, 2006.  
[http://www.cfr.org/publication/11834/military\\_strategies\\_for\\_unconventional\\_warfare\\_rush\\_transcript\\_federal\\_news\\_service.html](http://www.cfr.org/publication/11834/military_strategies_for_unconventional_warfare_rush_transcript_federal_news_service.html). (Last accessed July 2007).
- Campbell, Charles C., General. Commander, U.S. Army Forces Command. Presentation at the Infantry Warfighting Conference, September 18, 2007, Fort Benning, GA.
- Hagerstrom, Kristin, PRT team leader, and Major Lee Suttee, USMC Civil Affairs Chief. State Department briefing via satellite, August 24, 2007.  
<http://www.state.gov/p/nea/rls/91450.htm>. (Last accessed July 2007).
- Krepinevich, Andrew, Nadia Schadlow, and Marin J. Strmecki. "Stability, Security, Transition, and Reconstruction Operations: Meeting the Challenge." PowerPoint presentation, 7 March, 2007. Emailed to the author.
- Mattox, Ray, Captain, Captain Bobby Davis, Captain Pete Rodgers. "Information Operations (IO), The Great Disconnect: National Strategic Policy Meets the Challenges of Tactical Implementation." PowerPoint presentation, 2007, Naval Postgraduate School, Monterey, CA. Emailed to author.
- MacFarland, Sean, Colonel. Former commander, 1<sup>st</sup> Brigade, 1<sup>st</sup> Armored Division. Presentation at the Infantry Warfighting Conference, September 19, 2007, Fort Benning, GA.
- Moore, Ritchie, Lieutenant Colonel and Lieutenant Colonel Michael Warmack. "Civil Affairs Transformation." PowerPoint presentation dated March 24, 2005. As referenced by Cameron S. Sellars, "Provincial Reconstruction Teams: Improving Effectiveness." Draft thesis, Naval Postgraduate School, June 2007.
- Nicholson, John, Colonel. Former commander, 3<sup>rd</sup> Brigade Combat Team, 10th Mountain Division. Presentation at the Infantry Warfighting Conference, September 19, 2007, Fort Benning, GA.
- Satterfield, David M., Ambassador, Senior Advisor to the Secretary and Coordinator for Iraq. State Department briefing via teleconference, February 7, 2007.  
<http://www.state.gov/p/nea/rls/rm/2007/80216.htm>. (Last accessed July 2007).
- Shields, Mike, Colonel. Former commander, 172nd Stryker Brigade Combat Team. Presentation at the Infantry Warfighting Conference, September 19, 2007, Fort Benning, GA.
- Twomey, Andrew B., Brigadier General. "Cost of Modern War." PowerPoint presentation dated January 5, 2006. Emailed to the author.

Walker, Keith, Brigadier General, Deputy Director, Strategy, Plans, and Policy, HQ, Department of the Army. "Army Force Structure and Implementation of Directive 3000.05." PowerPoint presentation given at the National Defense University and CTNSP Short Course titled, "Force Structure for Stability Operations and Interagency Integration," Fort McNair, Washington D.C., May 23, 2007.

West, Bing. "The Coming Crash: Two Strategies on One Budget." PowerPoint presentation given at the National Defense University and CTNSP Short Course titled, "Force Structure for Stability Operations and Interagency Integration," Fort McNair, Washington D.C., May 24, 2007.

Yarborough, Brigadier General. Multi-National Corps Iraq. Presentation at the Infantry Warfighting Conference, September 18, 2007, Fort Benning, GA.

## **INTERVIEWS AND UNPUBLISHED SOURCES**

Boozell, James H., Lieutenant Colonel, AV, USA, Army G3/5/7 Branch Chief, Stability Operations and Irregular Warfare Division, October 17, 2007.

Clemente, Dominick, Captain, AR, USA, August 20, 2007.

England, Eric. "Six Steps to Victory, The bottom-up plan to defeat the insurgency." Unpublished article, email to author, November 16, 2006.

Gregory, Robert, Captain, AR, USA, August 24, 2007.

Hollenbeck, Neil, Captain, IN, USA, July 30, 2007 (email to the author).

Hunter, Leslie, Office of the Secretary of Defense, SOLIC, October 17, 2007.

Irizarry, Ferdinand, Colonel, CA, USA, former G3 USACAPOC and commander 95th CA BDE, April 14, 2007.

Ives, John, Major, MI, USA, September 5, 2007.

Mattox, Ray, Captain, IN, USA, August 22, 2007.

Perry, Justin, Lieutenant, Civil Engineer, USN, October 14, 2007.

Phillips, Kyle, Captain, AR, USA, August 24, 2007.

Sellers, Cameron, Major, CA, USA, April 14, 2007.

Shaw, Scott A. Major. "Taking the Mystery out of the Fort Riley MTT Training Experience." <https://cp.army.mil/CommunityBrowser.aspx?id=57600&lang=en-US>.

Southern, Morgan, Major, AR, USA, August 23, 2007.

Ulrich, Andy, Major (P), IN, USA, August 22, 2007 (phone interview).

## **NEWSPAPER ARTICLES**

"Army Looks for NCOs to Serve as Human Intelligence Collectors." *Army News Service*, March 28, 2007. <http://www.army.mil/-news/2007/03/28/2440-army-looks-for-ncos-to-serve-as-human-intelligence-collectors>. (Last accessed April 2007).

Associated Press. "U.S.: Iran Smuggling Missiles and Other Advanced Weapons into Iraq." *FoxNews.Com*, September 24, 2007. <http://www.foxnews.com/story/0,2933,297777,00.html>. (Last accessed October 2007).

Baldor, Lolita C. "Gates Envisions an Army Remade to Fight Future Wars." *Seattle Post-Intelligencer*, October 11, 2007.

Barnes, Julian E. "Gates Urges Funds for a Smarter Army." *Los Angeles Times*, October 11, 2007.

Barnes, Julian E. and Peter Spiegel. "Rethinking the U.S. Army." *Los Angeles Times*, October 10, 2007.

Cavallaro, Gina. "Casey Urges More Conventional Training." *Military Times*, August 17, 2007. [http://www.militarytimes.com/news/2007/08/army\\_casey\\_070814w/?fromrss=1](http://www.militarytimes.com/news/2007/08/army_casey_070814w/?fromrss=1). (Last accessed September 2007).

Cloud, David S. "Gates Says Military Faces More Unconventional Wars." *New York Times*, October 11, 2007.

Dreazen, Yochi J. "New Rebuilding Plan in Iraq Ignites Debate About Tactics." *Wall Street Journal*, April 19, 2007, 1.

Eisler, Peter, Blake Morrison, and Tom Vanden Brook. "Pentagon Balked at Pleas from Officers in Field for Safer Vehicles." *USA Today*, July 16, 2007, 1.

- Flaherty, Anne (associated press). "Pentagon seeks \$198B for wars." *The Monterey County Herald*, September 27, 2007, A3.
- Gertz, Bill. "China sub secretly stalked U.S. fleet." *The Washington Times*, November 13, 2006. [http://extendedremarks.blogspot.com/2006\\_11\\_13\\_archive.html](http://extendedremarks.blogspot.com/2006_11_13_archive.html). (Last accessed September 2007).
- Glanz, James. "Inspectors Find Rebuilt Projects Crumbling in Iraq." *The New York Times*, April 29, 2007.
- Graham, Bradley. "Alleged Desecration of Bodies Investigated." *Washington Post*, October 21, 2005.
- Hagel, Chuck. "Leaving Iraq, Honorably." *Washington Post*, November 26, 2006, B7.
- Kaufman, Marc and Dafna Linzer. "China Criticized for Anti-Satellite Missile Test." *Washington Post*, January 18, 2007. <http://www.washingtonpost.com/wp-dyn/content/article/2007/01/18/AR2007011801029.html>. (Last accessed September 2007).
- Owens, Mackubin Thomas. "Counterinsurgency Comeback." *Wall Street Journal*, September 6, 2007.
- Spiegel, Peter and Julian E. Barnes. "Rethinking the U.S. Army." *Los Angeles Times*, October 10, 2007.
- Tan, Michelle. "Deciding Who Goes, Where and When." *Army Times*, October 14, 2007.
- Tisdall, Simon. "Iran's Secret Plan for Summer Offensive to Force U.S. Out of Iraq." *The Guardian*, May 22, 2007. [http://www.guardian.co.uk/frontpage/story/0,,2085195,00.html#article\\_continue](http://www.guardian.co.uk/frontpage/story/0,,2085195,00.html#article_continue). (Last accessed September 2007).
- "Troops hit Midwest before Middle East," and "Soldiers learn survival techniques." *AUSA News*, August 2007, 9-13.

THIS PAGE INTENTIONALLY LEFT BLANK

## **INITIAL DISTRIBUTION LIST**

1. Defense Technical Information Center  
Ft. Belvoir, Virginia
2. Dudley Knox Library  
Naval Postgraduate School  
Monterey, California