

PART 1 GENERAL ORGANISATION OF CYCLING AS A SPORT

TABLE OF CONTENTS

	Page
Chapter I LICENCE HOLDERS	1
§ 1 Licences	1
§ 2 Categories of riders	9
§ 3 Teams	11
§ 4 Commissaires	12
§ 5 Team managers	17
Chapter II RACES	19
Section 1: administrative provisions	19
§ 1 Calendar	19
§ 2 Names of races	22
§ 3 Forbidden races	22
§ 4 Access to a race	23
§ 5 Sanction	23
§ 6 Classifications and cups	23
§ 7 National Championships	23
§ 8 Betting	24
Section 2: organisation of races	24
§ 1 Organiser	24
§ 2 Authorisation to organise the event	25
§ 3 Specific regulations	26
§ 4 Programme - technical guide	26
§ 5 Invitation - Enrolment	27
§ 6 Race headquarters / Secretarial office	29
§ 7 Course and safety	30
§ 8 Medical service	31
§ 9 Prizes	31
§ 10 Travel and subsistence expenses	32

Section 3: race procedures	33
§ 1 Supervision of the organisation and competition	33
§ 2 Conduct of participants in cycling races	33
§ 3 Team manager	34
§ 4 Team managers' meeting	34
§ 5 Entry check	35
§ 6 Start of the race	35
§ 7 Finish	36
§ 8 Awards ceremony	38
Section 4: supervision of races	38
§ 1 General provision	38
§ 2 Commissaires' panel	39
§ 3 Powers of the commissaires' panel	52
Section 5: UCI cups, series and classification	53
Chapter III EQUIPMENT	54
Section 1: general provisions	54
§ 1 Principles	54
§ 2 Technical innovations	54
Section 2: bicycles	55
§ 1 Principles	55
§ 2 Technical specifications	56
Section 3: riders' clothing	67
§ 1 General provisions	67
§ 2 Teams registered with the UCI	68
§ 3 Regional and club teams	69
§ 4 Leader's clothing	70
§ 5 National team clothing	72
§ 6 World champion's jersey	73
§ 7 National champion's jersey	75
§ 8 Continental champion's jersey	75
§ 9 Order of priority	76
Section 4: identification of riders	78

PART 1 GENERAL ORGANISATION OF CYCLING AS A SPORT

Chapter LICENCE-HOLDERS

§ 1 Licences

Definition

- 1.1.001** The licence is an identity document confirming that its holder undertakes to respect the constitution and regulations and which authorise him to participate in cycling events.

Principles

- 1.1.002** No-one who does not hold the requisite licence may participate in a cycling event organised or supervised by the UCI, the UCI continental confederations, the UCI member federations or their affiliates.

Participation by a person who does not hold the required licence shall be null and void, without prejudice to other penalties.

(text modified on 1.01.05).

- 1.1.003** The licence must be presented whenever requested by a duly authorised person.

- 1.1.004** Anyone requesting a licence thereby undertakes to respect the constitution and regulations of the UCI, the UCI continental confederations and the UCI member Federations, as well as to participate in cycling events in a sporting and fair manner. He shall undertake, in particular, to respect the obligations referred to in article 1.1.023.

As from the time of application for a licence and provided that the licence is issued, the applicant is responsible for any breach of the regulations that he commits and is subject to the jurisdiction of the disciplinary bodies.

Licence holders remain subject to the jurisdiction of the relevant disciplinary bodies for acts committed while applying for or while holding a licence, even if proceedings are started or continue after they cease to hold a licence.

(text modified on 1.01.04; 15.10.04).

- 1.1.005** The licence shall be issued and used under the exclusive responsibility of its holder or his legal representative.

The granting of the licence shall not imply that the issuing authority recognises or assumes any responsibility as to the aptitude of its holder, or for his compliance with the conditions of any law, statute or regulation.

- 1.1.006** Federations shall issue licences according to such criteria as they may determine. They shall be responsible for monitoring compliance with these criteria.

Before the licence is issued, the licence holder and the national federation must ensure inter alia that the licence holder is adequately insured against accidents and civil responsibility in every country where he practices competitive cycle sport or training throughout the year for which the licence is issued.

(text modified on 15.10.04).

- 1.1.007** Federations may make the issue of the licence subject to the payment of a licence fee, the amount of which they shall determine.
- 1.1.008** The licence shall be valid for one year, from 1 January to 31 December. It shall be valid in all countries where there is a UCI member national federation.
- 1.1.009** A licence holder may hold the licence of only one national federation.

Categories of licence holders

- 1.1.010** A licence shall be required for:

- 1.1 A rider (man or woman, all disciplines, all categories)
- 1.2 A participant in cycling for all
- 1.3 A pacer
A motor-cycle-mounted pacer (motorcycle, moped, demy)
- 1.4 Staff
 1. general manager
 2. team manager
 3. coach
 4. doctor
 5. paramedical assistant
 6. mechanic
 7. driver
 8. other function to be specified on the licence.
- 1.5 Officials
 1. federation administrator (status to be specified on the licence)
 2. commissaire (status to be specified on the licence)
 3. other role (e.g. timing/photo-finish operator, announcer, race radio operator, etc.) to be specified on the licence
- 1.6 Organiser
 1. organisational administrator
 2. other function to be specified on the licence.

Should a licence holder carry out multiple roles within cycling, he must apply and be licensed for each of these roles. It shall be the responsibility of the national federation to issue the licence corresponding to the primary role as per the order set out above. In addition to the licence, the national federation shall issue a certificate setting out the other roles for which the licence holder is recognised.

A rider belonging to a team registered with the UCI may not carry out another role.

(article modified on 1.01.00; 15.10.04).

Issuing procedure

- 1.1.011** The licence shall be issued by the federation of the country where, according to the legislation of that country, the applicant has his main residence at the time of application. He shall remain affiliated to that federation until the expiry of the licence, even if he changes country of residence.
- 1.1.012** National federations shall refuse to issue a licence in the event of an irregular application.
- 1.1.013** In the case of a country where there is no UCI member federation, the licence shall be issued by the UCI.
- 1.1.014** If a national federation does not respond to a licence application within 30 days of its being filed, the applicant may lodge his licence application with the UCI.
- 1.1.015** If the UCI or a federation deems that it cannot issue the requested licence, it shall inform the applicant to that effect stating its reasons by registered letter with recorded delivery. Similarly, the applicant shall be invited to defend his application, as appropriate, before such person or commission as may be designated by the president of the UCI or as indicated in the regulations of the federation or, where the regulations contain no such mention, by its president.
- The applicant shall be entitled to consult his file. He shall be entitled to present his argument and to enlist the assistance of or be represented by any person of his choice bearing a proper power-of-attorney.
- 1.1.016** The applicant shall be informed of both the refusal to issue the licence and of the reasons for the refusal by registered letter with recorded delivery.
- 1.1.017** A refusal to issue a licence shall be open to appeal before the UCI appeals board in following cases:
- the applicant has had no opportunity to present his arguments;
 - no reason was given for the decision;
 - the reasons for the refusal contain factual errors;
 - the refusal is irregular.

The appeal shall be lodged within 30 days of reception by the applicant of the notification of refusal.

- 1.1.018** A national federation may bring an appeal, before the UCI appeals board, against the issuing of a licence by another federation if the issuing federation did not have territorial jurisdiction or if the licence was irregularly issued.

This appeal shall be lodged within 15 days of the federation being informed about the issue of the licence, but at the latest within three months of the licence being issued.

(text modified on 1.01.00).

- 1.1.019** The issuing of a licence by the UCI shall be subject to the payment of an amount set annually by the management committee. To that amount shall be added such insurance premium as the UCI deems proper to take out for the rider.

- 1.1.020** Any member federation of which a licence holder possesses the nationality shall be informed within one month of the licence holder's application and the issuing of the licence in the following cases:
- a) if the applicant does not hold the nationality of the federation to which he applied;
 - b) if the applicant holds the nationality of the federation to which he applied but also of one or more other national federations;
 - c) if the licence application is made to the UCI.

(text modified on 1.01.00).

Licence

- 1.1.021** The licence application shall be made on a form to be prepared by each federation. The form must at least include the information and the undertakings stated in the following model:

1.1.022 Front

INTERNATIONAL CYCLING UNION NAME OF THE NATIONAL FEDERATION

1. Category for which the licence is requested UCI: national:
2. Surname and first name:
3. Date of birth:
4. Nationality:
5. Gender:
6. Place and address of main residence at the time of application:
7. Place and country of the previous main residence if changed in the last year:
8. Countries in which the applicant has other residences:
9. Authority (federation or UCI) that issued the applicant's previous licence:
10. Authority (federation or UCI) that has refused to issue a licence during the past three years:
11. Applicant's club:
12. Applicant's UCI team (name and type):
13. If the applicant is currently suspended and will continue to be for all or part of the year of validity of the licence, the name of the authority that imposed the suspension and the starting and ending dates of the suspension:

14. Insurance for bodily injury (in and out-patient hospital expenses and medical care, transport costs, permanent disablement, death) and material damages (loss of earnings) in case of accident on the occasion of a cycling competition or event or during training:
 - name and address of the insurance company;
 - name and address of the insured party;
 - duration of validity of the insurance policy,
 - amount of cover guaranteed
 - territorial validity.
15. Third-party liability insurance for material damage or bodily injury caused to others in the course of a competition or cycling event or during training:
 - name and address of the insurance company;
 - name and address of the insured party;
 - duration of validity of the insurance policy,
 - amount of cover guaranteed
 - territorial validity.

(article modified on 15.10.04).

Back

1.1.023

1. I hereby declare that I am aware of no reason why I should not be granted the requested licence.

I undertake to spontaneously return my licence in the event of any substantial change to the circumstances existing at the time of the application for a licence.

I declare that I have not applied for a licence for the same year to the UCI or to any other national federation.

I assume exclusive liability for this application and for the use that I shall make of the licence.

2. I hereby undertake to respect the constitution and regulations of the International Cycling Union, its continental confederations and its national federations.

I declare that I have read or have had the opportunity to become acquainted with the aforesaid constitution and regulations.

I shall participate in cycling competitions or events in a sporting and fair manner.

I shall submit to disciplinary measures taken against me and shall take any appeals and litigation before the authorities provided for in the regulations. I accept the Court of Arbitration for Sport (CAS) as the sole competent body for appeals in such cases and under the conditions set out in the regulations. I accept that the CAS shall be the court of last instance and that its decisions shall be definitive and without right of appeal. With those reservations, I shall submit any litigation with the UCI solely to the courts within whose jurisdiction the head offices of the UCI lie.

3. I agree to submit to and be bound by the UCI antidoping regulations, the clauses of the World Antidoping Code and its international Standards to which the UCI antidoping regulations refer and to the antidoping regulations of other competent bodies as per the regulations of the UCI and the World Antidoping Code provided that they comply with that Code.

I agree that the results of the analysis may be made public and communicated in detail to my club or team or to my paramedical assistant or doctor.

I agree that all urine samples taken shall become the property of the UCI which may have them analysed, especially for purposes of health protection research and information.

I agree that my doctor or the doctor of my club or team may, on a request from the UCI, communicate to it a list of any medicines I may take and treatment I may undergo before any given competition.

4. I accept the conditions regarding blood testing and accept to undergo blood tests.

Date:

Signature of applicant:

Signature of club chairman:

(text modified on 1.01.00; 13.08.04; 15.10.04)

Form of licence

1.1.024 The licence shall be in the form of a credit card.

It shall include the following data:

On the front

INTERNATIONAL CYCLING UNION		
NAME OF THE NATIONAL FEDERATION		
UCI Category:	UCI Code:	YEAR
National Category:	Number:	
Surname:	Date of birth:	
First name:	Address:	
Nationality:	Gender: M / F	
Team:		
Club:		
Issued on:		

On the back

INTERNATIONAL CYCLING UNION NAME OF THE NATIONAL FEDERATION	
Should the photograph not be required, the holder must always be able to present his licence together with an other ID document bearing his photo.	The holder agrees to abide by the regulations of the UCI and of the national federations. He accepts antidoping and blood tests provided by the rules and the sole competence of the CAS.
Signature of the President:	Signature of the holder:

(text modified on 6.10.97; 1.01.04; 13.08.04; 15.10.04).

- 1.1.025** The licence shall be written in French or English. Other language versions of its text may also appear.
- 1.1.026** The licence shall be signed by the president of the national federation that issued it or by the president of the UCI and by the holder. The holder shall sign under the declaration which reads «The holder agrees to abide by the regulations of the UCI and of the national federations. He accepts antidoping and blood tests provided by the rules and the sole competence of the CAS».
- (text modified on 6.10.97; 15.10.04).*
- 1.1.027** (N) The national federation shall determine whether the photograph of the holder has to appear on the licence. Should the photograph not be required, the holder must always be able to present his licence together with an other ID document bearing his photo.

- 1.1.028** The colour of the licence shall differ from year to year in the order given hereafter:
 2005: red
 2006: green
 2007: white
 2008: yellow
 2009: blue
 2010: red
 etc.

(text modified on 1.01.04; 15.10.04).

Penalties

- 1.1.029** The following infringements shall be penalised as indicated below:
- 1) participation or attempt to participate, in a cycling competition or event without holding the requisite licence:
 - start refused
 - and
 - a waiting period of one year before obtaining a licence

- 2) participation or attempt to participate, in a cycling competition or event without carrying the licence:
- start refused or disqualification
 - and
 - fine of 50 to 100 Swiss francs

Other than in cases of negligence, the penalty shall not apply if the licence holder's status as not suspended is determined in another manner.

(text modified on 15.10.04).

Sundry provisions

- 1.1.030** National federations may permit, under such conditions as they may determine, persons who take part in cycling events only occasionally to take part in a particular event at national level without holding a licence valid for a whole year. These conditions must include agreement to abide by the regulations of the UCI and the national federation and suitable insurance for the whole day or all days of the event.

(text modified on 1.01.05).

- 1.1.031** Articles 1.1.011 to 1.1.029 shall not apply to riders in the youth category, such matters being governed by the national federations.

- 1.1.032** A licence holder whose licence is withdrawn because of a suspension the effect of which is limited to the territory of his national federation, may obtain a provisional authorisation from the UCI which is valid in all other UCI member countries. Such a provisional authorisation shall in all other respects be subject to the rules governing the licence.

- 1.1.033** § 1 A rider may be selected solely by the federation of his nationality to participate in world championships, continental championships, and regional games or to be part of teams participating in cyclo-cross world cup and mountain bike world cup events, regardless of the federation that issued his licence. The rider shall be subject to the regulations and the discipline of the national federation of his nationality in all matters concerning his selection for the national team.

A stateless rider may be selected only by the national federation of a country where he has been continuously in residence for at least five years.

- § 2 A rider holding multiple nationalities shall be required to choose between them on the occasion of first applying for a licence. This choice of nationality shall be final for the rider's entire career unless he loses that nationality for any reason, without prejudice to the application of the third paragraph below.

The rider shall be deemed to hold the nationality thus chosen for any matter regarding the UCI regulations.

Such a rider may choose another nationality which he legitimately holds, if when first electing a nationality the rider was a minor under the relevant laws of each of the nationalities in question, and the choice is made on the first application for a licence after he reaches the age of majority under the laws of each nationality in question.

§ 3 A rider who acquires an additional nationality may choose this nationality. Such a choice shall be final, and shall be made at the latest by the second application for a licence following the acquisition of the new nationality.

§ 4 The determination of a country that a rider can represent at the Olympic Games is governed by the Olympic Charter.

(text modified on 8.06.00; 1.01.04).

§ 2 Categories of riders

Competitive cycling

1.1.034 For participation in events on the international calendar, riders' categories are determined by the age of those competing as defined by the difference between the year of the event and the year of birth of the rider.

(text modified on 1.01.05).

1.1.035 Without prejudice to relevant legal provisions, only riders aged 17 or more to whom a licence for one of the international categories below has been issued shall have the right to take part in events on the international calendar. However, riders aged 16 or under may take part in international BMX events if the applicable legislation does not prohibit it.

(text modified on 1.01.05).

Men

1.1.036 Youth

This category denotes riders aged 16 years or under and is controlled by national federations, except as provided for BMX in article 1.1.035.

Juniors (MJ: Men Juniors)

This category shall comprise riders aged 17 and 18.

Under 23 (MU: Men Under 23)

This category shall comprise riders aged 19 to 22.

A rider of this age who is a member of a UCI Pro Team shall be deemed ipso facto elite.

If such a rider, who is still under 23, ceases to belong to a UCI Pro Team by virtue of which he qualified as elite, he will be requalified in the under 23 category.

Elite (ME: Men Elite)

This category shall comprise riders aged 23 and above.

Masters (MM: Men Masters)

This category shall comprise riders of 30 years and above who elect this status. The choice of masters status shall not be open to a rider belonging to a team registered with the UCI.

Riders with disabilities

This category shall comprise riders with disabilities as specified by the International Paralympics Committee's (IPC) functional classification system for cycling. A rider with disabilities may, or may not for health and safety reasons, be issued with an additional category from the current list. This depends on the degree and nature of the disability. The rider may be required to provide proof of his functional classification.

(text modified on 1.01.03; 1.01.04; 1.01.05).

Women**1.1.037 Youth**

This category denotes riders aged 16 years or under and is controlled by national federations, except as provided for BMX in article 1.1.035.

Juniors (WJ: Women Juniors)

This category shall comprise riders of 17 and 18 years old.

Elite (WE: Women Elite)

This category shall comprise riders of 19 years and above.

Masters (WM: Women Masters)

This category shall comprise riders of 30 years and above who elect this status. The choice of the masters status shall not be open to a rider belonging to a team registered with the UCI.

Riders with a handicap

This category shall comprise riders with disabilities as specified by the International Paralympics Committee's (IPC) functional classification system for cycling. A rider with disabilities may, or may not for health and safety reasons, be issued with an additional category from the current list. This depends on the degree and nature of the disability. The rider may be required to provide proof of his functional classification.

(text modified on 1.01.03; 15.10.04).

1.1.038 Designations may be adapted in national languages according to linguistic constraints.

Cycling for all

- 1.1.039** A cycling for all licence is issued to the cyclists practising cycling as a leisure activity. This licence shall give access only to events on the cycling for all calendar.

(text modified on 1.01.05).

§ 3 Teams**Definitions**

- 1.1.040** Under these regulations a team is a sports organisation comprising riders and persons supporting them with the aim of taking part in cycling events. Depending on the context the term "team" may also denote the riders of a team who are taking part in a given event.

(article introduced on 1.01.05).

- 1.1.041** Teams registered with the UCI
The following teams are teams registered with the UCI:
UCI Pro Team: see articles 2.15.047 et seq.
UCI professional continental team: see articles 2.16.001 et seq.
UCI continental team: see articles 2.17.001 et seq.
UCI women's team: see articles 2.18.001 et seq.
UCI mountain-bike team: see articles 4.10.001 et seq.
UCI track team: see articles 3.7.001 et seq.

The reference to the UCI in the name of the categories of team above refers only to the fact that the team has been registered with the UCI under the present regulations.

(article introduced on 1.01.05).

- 1.1.042** A rider who is part of a team registered with the UCI may not enter into commitments to an organiser, whoever he may be, to take part in an event unless he has obtained prior consent from his team. That agreement shall be considered to have been granted if, on being duly requested, no answer has been received within ten days.

Any rider in breach of this regulation shall be disqualified and fined from 300 to 5000 Swiss francs.

(article introduced on 1.01.05).

- 1.1.043** A rider whose team is entered in a race may not participate independently of his team, offenders will be disqualified and fined from 300 to 2000 Swiss francs.

(article introduced on 1.01.05).

National team

1.1.044 A national team is a team of riders selected by the national federation of their nationality.

(article introduced on 1.01.05).

Regional team

1.1.045 A regional team is a team of riders selected by a territorial or other division of a national federation and composed of riders licensed by that federation who do not belong to a team registered with the UCI.

(article introduced on 1.01.05).

Club team

1.1.046 A club team is a team affiliated to a national federation. Its composition shall be regulated by the national federation, except insofar as the riders may not belong to a team registered with the UCI.

(text modified on 1.01.05).

§ 4**Commissaires**

(numbering of articles modified on 1.01.05).

(articles 1.1.112 and 1.1.122 abrogated on 1.01.04, the previous article 1.1.125 on 1.01.05)

1.1.047 The commissaire is an official appointed by the UCI or a national federation to ensure that cycling events comply with the provisions of the regulations that may apply.

1.1.048 Commissaires, both individually and/or in a panel shall direct the sporting aspects of cycling events and ensure that the event be in all respects conducted according to the regulations. They shall, in particular, ensure that the regulations specific to a race, the manner in which it is conducted and all technical provisions relating thereto comply strictly with the applicable provisions of the regulations.

Commissaires shall record breaches of the regulations and pronounce the foreseen penalties.

1.1.049 The commissaires' panel shall comprise commissaires appointed to supervise a given cycling event.

It shall record decisions of individual commissaires and shall apply and/or confirm the penalties imposed.

1.1.050 Each commissaire shall act neutrally and independently. He may in no way be involved in the organisation of the race. He shall immediately decline his appointment if he is aware of any aspect that could cast doubt on his neutrality.

1.1.051 The title of commissaire shall be conferred by the national federation competent to issue his licence. National federations shall determine the eligibility, status and functions of commissaires in accordance with the principles mentioned above.

1.1.052 Except where an exemption is granted by the UCI, a commissaire other than an UCI international commissaire may officiate only in the country of his national federation.

(text modified on 1.01.05).

UCI international commissaires

Conditions of appointment

1.1.053 The title of UCI international commissaire shall be conferred by the UCI to persons having passed the examination **and the practical assessment** referred to in article 1.1.058.

(text modified on 1.01.07).

1.1.054 **To be able to be admitted to the selection procedure to become UCI international commissaire, the concerned person has to meet the following conditions:**

- 1) be a member or licence holder of a UCI-affiliated national federation
- 2) **be proposed by that national federation. This federation shall be required to submit an application signed by its president or a person delegated by its president which shall include the following documentation:**
 - **a copy of an official identity document (passport, etc.) showing that the candidate is aged between 25 and 50 years in the year of their selection by the UCI**
 - **evidence of their having followed and passed a training course for national commissaires given by a person approved by the UCI**
 - **evidence that they have served actively as a national commissaire in the 2 years preceding the selection**
- 3) **have an excellent knowledge of the UCI regulations**
- 4) have a command of the official course language, which will be one of the two official UCI languages (French or English).

The UCI operates a first selection, based on the files received and the places available. The candidates selected must follow the course and pass the pre-selection examination, in which the knowledge of the Regulations and the language of the course shall be tested.

The pass in this examination shall remain valid for a period of five years. In case of failure, the candidate shall be permitted to retake the examination only once.

If a false statement is made, the candidate shall be excluded from **every** course or examination. Where appropriate, he shall be stripped of the title of international commissaire. The person in question may lodge an appeal with the appeals board.

(text modified on 1.01.03; 1.04.05; 1.01.07).

1.1.055 The candidates having passed the preselection test are admitted to the training course for international commissaries.

Training shall be given by instructors **recognized by the UCI**.

(text modified on 1.01.07).

1.1.056 The training shall concentrate essentially on specialisation in one of the disciplines of cycling. It shall cover both the theoretical knowledge of the regulations and their practical application in the field.

1.1.057 Class and examination sessions shall be organised separately for each different type of programme.

The syllabus for each training course shall comprise a general part common to all disciplines and a special part specific to each discipline/**category**:

General part:

- UCI constitution (general)
- general organisation of cycling as a sport
- world championships
- **continental championships**
- **Olympic Games (for Olympic disciplines)**
- discipline and procedures
- **sports safety and conditions**
- antidoping controls (general)
- the psychological aspects and ethics of the position of international commissaire

Disciplines / categories

- road
- track
- mountain bike
- cyclo-cross
- BMX
- trials
- cycle-ball
- artistic cycling
- cycling for riders with disabilities

(text modified on 1.01.05; 1.01.07).

- 1.1.058** The examination committee shall consist of the course **instructors**. **The theory** examination shall comprise a written part and an oral part. The written examination shall carry two-thirds of the points, the oral examination one third. **In the event of failure, the candidate shall be permitted to retake the examination a second time. Two failures in the same discipline shall result in exclusion for the examinations in the other disciplines.**

(text modified on 1.01.03; 1.01.07).

- 1.1.059** **Within 12 months following the examination, the candidate has to pass a practical validation as president of the commissaires panel in an international event. Such assessment shall be effected by a UCI trainer. In the event of failure, the candidate shall be permitted to retake the assessment only once.**

(text modified on 1.01.07).

- 1.1.060** To acquire the title of UCI international commissaire a candidate shall obtain 2/3 of the maximum points **in the theory examination and have passed the practical assessment.**

(text modified on 1.01.05; 1.01.07).

- 1.1.061** Candidates obtaining less than **2/3** of the maximum points shall receive a certificate indicating that they participated in the training course.

(text modified on 1.01.04; 1.01.07).

- 1.1.061 bis** **International commissaires shall be assessed periodically in order to be able to retain their position.**

An assessment panel appointed by the commissaires' unit shall conduct this assessment. The members of the panel may not be serving as international commissaires.

(article introduced on 1.01.07).

Status

- 1.1.062** A UCI international commissaire can not at the same time:
- be the holder of a licence as a rider of a team registered with the UCI;
 - exercise any technical function (team assistant, mechanic, paramedical assistant, team manager, etc.) for a national federation or for a team registered with the UCI.
 - **Exercise an elected function within a national federation.**

(text modified on 1.01.00; 1.01.05; 1.01.07).

- 1.1.063** Members of the UCI management committee as well as UCI staff members may not officiate as

international commissaires.

(text modified on 6.10.97).

1.1.064 The active career of an international commissaire shall end on 31 December of the year in which he reaches the age of **70**. Nevertheless he may be appointed as antidoping inspector beyond that age.

(text modified on 1.01.07).

1.1.065 All international commissaires shall be subject to UCI discipline when appointed by the UCI.

1.1.066 Should an international commissaire, even when not officiating as such, commit a breach of the UCI regulations or should he cause any material or moral prejudice whatsoever to cycling as a sport or to the UCI, he shall be disciplined by one of the following measures:

- his services shall not be used for a period to be determined;
- he shall be struck off the list of international commissaires.

1.1.067 The matter shall be brought before the UCI appeals board by the UCI.

(text modified on 6.10.97; 1.01.03).

1.1.068 The UCI shall be obliged to submit the case of a commissaire if his national federation so requests. That request has to be reasoned and accompanied by documentary evidence.

(text modified on 6.10.97; 1.01.03).

Mission

1.1.069 The title of UCI international commissaire shall not in itself confer the right to be entrusted with a mission.

1.1.070 The UCI's administrative offices shall designate one or more commissaires for international calendar races as it may deem fit, be it as president of the commissaires' panel, as a member of the commissaires' panel or as antidoping inspector.

(text modified on 15.10.04).

1.1.071 An international commissaire, if not appointed by the UCI, may be appointed by his national federation to officiate in its country.

1.1.072 A UCI international commissaire may not accept a mission abroad without the agreement of his national federation, other than when appointed by the UCI.

1.1.073 International commissaires appointed for a mission by the UCI shall be entitled to reimbursement of

their expenses, the amounts and payment conditions of which shall be determined by the management committee.

- 1.1.074** International commissaires appointed by the UCI or who sit on a commissaires' panel, the president of which is appointed by the UCI, shall wear the official uniforms provide by the UCI. Such uniforms may be worn solely during such missions.

§ 5 Team managers

- 1.1.075** Each team, except regional teams and club teams, must nominate a single person as team manager.

If, within a team more than one person carries the title team manager the rules stipulated in this article shall apply to the duly appointed team manager under the terms of the first part of the article above.

(text modified on 15.10.04).

- 1.1.076** No team shall be registered with the UCI or recognised by it as a national team if no team manager has been appointed.

No team may take part in events on the international calendar if it has not appointed a team manager.

(text modified on 15.10.04).

- 1.1.077** The team manager shall hold the appropriate licence.

(text modified on 15.10.04).

- 1.1.078** Besides the tasks and responsibilities which are provided for in the regulations, the team manager shall be responsible for the organisation of the sporting activities and for the social and human conditions in which the riders practise the sport of cycling within the team.

(text modified on 1.01.05).

- 1.1.079** The team manager shall constantly and systematically strive, wherever possible, to improve social and human conditions and protect the health and safety of the team's riders.

(text modified on 1.01.05).

- 1.1.080** The team manager shall ensure that the regulations are complied with by all those who belong to the team or who work for it in whatever capacity. He shall set an example to the others.

(text modified on 1.01.05).

- 1.1.081** The team manager shall ensure that there is specialist assistance for the team in the following areas: medicine, treatment in accordance with article 13.3.001 and equipment. He shall ensure that assistance is given by qualified persons and, where required, holders of a licence in accordance with the regulations.

(text modified on 1.01.04; 1.01.05).

- 1.1.082** The team manager shall ensure that tasks are appropriately divided between all the persons mentioned in article 1.1.080, with the exception of the riders. The tasks for each person shall be clearly specified and respect the regulations. Those persons with titles shall be listed by name. The division of tasks shall be in written form. A copy shall be given to all persons mentioned in 1.1.080. A copy shall also be submitted to the national federation. Teams registered with the UCI and national teams shall also submit a copy to the UCI.

(text modified on 1.01.05).

- 1.1.083** The team manager shall regularly consult all persons mentioned in article 1.1.080 regarding human and social conditions, equipment, risks involved in cycling and the competition schedule for each rider. He shall make a report on each consultation. Upon their request, a copy of the reports shall be submitted to the national federation or the UCI.

(text modified on 1.01.05).

- 1.1.084** Any failure by a team manager to meet the obligations imposed under this paragraph shall be penalised by a suspension of between 8 days and ten years, and/or a fine of between 500 and 10 000 Swiss francs. In the event of a subsequent offence occurring within two years of the first, the team manager shall be suspended for a period of at least six months or excluded permanently and fined between 1000 and 20 000 Swiss francs.

(text modified on 1.01.05).

- 1.1.085** Any person or team failing to respect the division of tasks under article 1.1.082 will be penalised by a suspension of between one month and one year and/or a fine of between 750 and 10 000 Swiss francs. If a second infraction is committed within two years, it will be penalised with a suspension of between six months minimum or with permanent exclusion and a fine of between 1500 and 20 000 Swiss francs.

(text modified on 1.01.05).

- 1.1.086** The team manager may be held responsible for infractions committed by persons indicated in article

1.1.080 and shall be penalised under the provisions for the infraction in question, unless he can demonstrate that the infraction cannot reasonably be considered to have been caused by negligence on his part, and that he did not endorse it in any way.

(text modified on 1.01.05).



Chapter RACES

Section 1: administrative provisions



Calendar

1.2.001 The calendar is the chronological list of cycling races by discipline, category and/or gender.

The procedure for the awarding of licences to organisers has yet to be determined.

1.2.002 A calendar shall be drawn up for the following disciplines:

1. road
2. track
3. mountain bike
4. cyclo-cross
5. BMX
6. trials
7. indoor cycling (cycle ball and artistic cycling)
8. cycling for all
9. cycling for riders with disabilities

(text modified on 15.10.04).

1.2.003 The calendar shall be prepared annually for a calendar year or a season.

1.2.004 In each discipline a world calendar, a continental calendar by continent and a national calendar by national federation shall be prepared.

The international calendar comprises the world calendar and continental calendars.

An international race is a race entered on a world calendar or on a continental calendar.

A national race is a race entered on a national calendar

(text modified on 1.01.01).

- 1.2.005** With the exception of UCI ProTour events, the world and continental calendars are as determined by the UCI management committee on the advice of the continental confederations for the competitions which concern them.

(text modified on 15.10.04).

The calendar of UCI ProTour events is drawn up by the UCI ProTour Council, in line with the provisions concerning the UCI ProTour in Part II, section XV.

(text modified on 15.10.04).

- 1.2.006** Each year, organisers shall apply to their respective national federations to have their races included on the world or continental calendar.

The organiser of a track, cyclo-cross or mountain bike event in which riders of 3 or more foreign federations participated, 2 foreign federations for an Indoor cycling event, must request the inclusion of the next edition of his event on the international calendar. The event shall not be included in the national calendar, except if its inclusion in the international calendar is rejected.

National federations shall pass on applications for inclusion to the UCI with a copy to their continental confederation no later than June 1st of the year preceding that for which inclusion is required. For cyclo-cross, the deadline shall be set at December 15th.

If a race is run over the territory of several countries, the race shall be included on the calendar only with the agreement of the federation of each country concerned.

If a federation does not transmit a request for inclusion on a calendar, the organiser of the race may approach the UCI directly.

(text modified on 1.06.98; 1.01.03; 1.01.04; 1.01.05).

- 1.2.007** The draft continental calendars shall be sent by the UCI to the respective continental confederations which may state their opinions thereon within 30 days of the despatch of the draft.

Continental confederations shall, whenever publishing their continental calendars, include world calendar races that are run on their territories.

- 1.2.008** National calendars shall be prepared by the respective national federations.

Federations shall, when publishing their national calendars, include international calendar races that

are run in their countries.

(text modified on 1.01.05).

- 1.2.009** The first time a race is submitted for inclusion on the international calendar, the organiser shall submit documentation including at least the following information:
- type of race (discipline, speciality, format);
 - description of the course including total length (in km) and, where applicable, that of stages and circuits;
 - the type and number of participating teams and/or riders' categories wanted;
 - financial aspects (prizes, travel and subsistence expenses);
 - references concerning organisation.

The documentation must be submitted to the UCI no later than three months before the meeting of the management committee at which the calendar in question is finalised.

(text modified on 1.01.98; 1.01.04; 1.01.05).

- 1.2.010** *[text modified on 1.01.04, abrogated on 1.01.05].*

- 1.2.011** If the documentation is accepted, the race shall be registered for a probationary year, on a date compatible with the existing calendars. The race may be supervised by a UCI delegate at the expense of the organiser.

(text modified on 1.01.99).

- 1.2.012** The inclusion of a race on the international calendar shall be subject to the payment of a fee, called the calendar fee, the amount of which shall be set annually by the UCI management committee.

The total amount of the fee must be paid by the organiser to the UCI no later than two months after the meeting of the management committee at which the calendar for the discipline in question is approved. The above deadline is the date on which the UCI account must be credited.

In case of delay, a penalty of 100 Swiss francs for each started month will automatically be applied.

The inclusion of the race on the following calendar shall be refused should the fee, as well as the penalty not have been paid one month before the meeting of the management committee at which the calendar in question is approved.

Furthermore, a race inscription shall be refused if the enrolment fees for previous races have not been paid or if the organiser does not honour its financial obligations with the UCI. This measure also applies to the new organiser of the race and, in general, to the organiser and/or race that the management committee considers to be the successor of another organiser or another race.

(text modified on 1.06.98; 1.02.03; 1.01.04; 1.01.05).

- 1.2.013** A rejection of an application for inclusion on the international calendar is decided by the UCI man-

agement committee. The organiser shall be allowed to put his case. If the organiser has not had an opportunity to defend his application, he may lodge an appeal with the appeals board.

(text modified on 2.03.00; 1.01.05).

- 1.2.014** Any change to the date of an event included on the international calendar shall be subject to prior authorisation by the UCI or, for a UCI ProTour event, the UCI ProTour Council at the request of the national federation of the organiser. If there is a change of date or if an event is cancelled, the organiser shall be liable for a fine the amount of which shall be set each year by the management committee, subject to recourse to the appeals board.

(text modified on 2.03.00; 1.01.05).

§ 2 Names of races

- 1.2.015** The organiser cannot call his event by any name other than that under which it was entered on the calendar.
- 1.2.016** The national federation and the UCI may ask that the name of the race be altered, for instance to avoid confusion with another race.
- 1.2.017** No race may be designated as a national, regional, continental, world, cup or championship event, save in the cases expressly provided for in the UCI regulations or unless prior and express authorisation has been obtained from the UCI or the competent national federation with respect to races on its national calendar.
- 1.2.018** The organiser shall avoid giving the impression that his race has a status that it does not have.

§ 3 Forbidden races

- 1.2.019** No licence holder may participate in an event that has not been included on a national, continental or world calendar or that has not been recognised by a national federation, a continental confederation or the UCI.
- A national federation may grant special exceptions for races or particular events run in its own country.
- 1.2.020** Licence holders may not participate in activities organised by a national federation that has been suspended, save in application of article 18.2 of the UCI constitution.
- 1.2.021** Breaches of articles 1.2.019 or 1.2.020 shall render the licence holder liable to one month's suspension and a fine of 50 to 100 Swiss francs.

§ 4 Access to a race

1.2.022 No suspended licence holder may be admitted to a race or to zones not accessible to the public.

Anyone knowingly engaging or entering a suspended rider for a race shall be fined between 2000 and 10 000 Swiss francs.

1.2.023 The organiser shall grant accreditation and free access to members of the bodies of its national federation and of the UCI.

§ 5 Sanction

1.2.024 The result of each race shall be sanctioned by the national federation of the organiser as fast as possible after the end of the competition.

(text modified on 1.01.98; 1.01.05).

1.2.025 National federations shall make absolutely sure that the results of the race are not being contested before sanctioning them.

§ 6 Classifications and cups

1.2.026 National federations, their affiliates and licence holders and, in general, all bodies answerable to them shall be barred from participating actively or passively in any individual or team classification based on the races on the international calendar other than those drawn up or expressly authorised by the UCI.

Events conducted by an organiser who fails to comply with the preceding paragraph shall be deleted from the international calendar for the following year.

(text modified on 1.08.00; 1.01.05).

§ 7 National Championships

1.2.027 National championships shall be ridden under UCI regulations.

1.2.028 Participation in national championships shall be regulated by the respective national federations. Only riders who have held the nationality of the country for the purposes of the present regulations as from January 1st of the year may compete for the title of national champion and the relevant points.

If a national federation organises a separate event to award the national champion's title in a given category, riders in this category may not take part in the national championship event in another category. A maximum of three national federations may organise their national championships as a joint event.

(text modified on 1.01.05).

1.2.029 National road championships shall be run on the 26th weekend of the year.

The national cyclo-cross championships **shall be run on the date approved by the Management Committee.**

National mountain bike championships shall be run on the 29th weekend of the year.

The UCI may grant dispensations for the southern hemisphere or in exceptional circumstances.

(text modified on 1.01.04; 1.01.05; 1.09.05; 1.01.06).

§ 8**Betting**

1.2.030 Anyone subject to the UCI regulations may not be involved directly or indirectly in the organisation of bets on cycling competitions, under penalty of a suspension of between 8 days and one year and/or a fine of 2000 to 200 000 Swiss francs.

In addition, if an organiser is involved, any competition organized by him may be excluded from the calendar for one year.

(text modified on 1.01.00; 1.01.05).

Section 2: organisation of races

(numbering of articles modified on 1.01.05).

§ 1**Organiser**

1.2.031 The organiser of a cycling race shall be licensed as such. He shall be a licence holder of the national federation of the country where the race is run.

1.2.032 The organiser shall be entirely and exclusively responsible for the organisation of his race, with respect both to compliance with UCI regulations and to the administrative, financial and legal aspects.

The organiser alone shall be responsible to the authorities, participants, attendants, officials and spectators.

The organiser shall be responsible for financial obligations arising from previous occasions on which that event was organised by a third party or from those to which his event is considered to be the successor by the management committee or, where the event in question is a UCI ProTour event, by the UCI ProTour Council.

(text modified on 2.03.00; 1.01.05).

1.2.033 Monitoring by the UCI, national federations and by the commissaires of the conduct of the race shall concern only the sporting requirements and the organiser alone shall be answerable for the quality and safety of the organisation and installations.

1.2.034 The organiser shall take out insurance covering all risks relating to the holding of his race. This insurance must nominate the UCI as a jointly insured party and cover claims which may be made against the UCI in connection with the event.

(article modified on 1.01.05).

1.2.035 The organiser shall take whatever safety measures caution demands.

The organiser shall ensure that the race may take place under the best material conditions for all parties concerned, riders, attendants, officials, commissaires, journalists, security services, medical services, sponsors, the public, etc.

Unless otherwise specified, the organiser must provide all the equipment required for the organisation of the event, including all timing equipment.

(text modified on 1.01.06).

1.2.036 The organiser shall always strive to attain the best quality of organisation possible with the means at his disposal.

§ 2

Authorisation to organise the event

1.2.037 A cycle race may be organised only if it has been included on a national, continental or world calendar.

The inclusion of the race on the calendar means that its organisation has been authorised, but does not imply that the UCI or the national federation that registered it undertake responsibility for it.

1.2.038 In addition, the organiser shall obtain any administrative authorisations required under the laws and regulations of the country where the competition is held.

(text modified on 1.01.05).

1.2.039 The organiser shall, within the deadline set by his national federation, submit to it the technical file on that race comprising at least the following data (if applicable):

- the specific regulations for the race; these regulations may not be published in the programme until they have been approved by the national federation;
- programme and schedule of competitions;
- invited riders (categories of rider, teams, etc.);
- entry procedure, distribution of identification numbers;
- list of prizes;
- financial conditions relating to travel and subsistence expenses;
- arrangements for in competition feeding (method, number, feed zones, etc.);
- transport arrangements for participants and baggage;
- description and detailed plans of the track or circuit, including start and finishing zones;
- location of podiums and rooms for antidoping tests, secretarial offices, pressroom, etc.;
- arrangements regarding police and security forces and set-up in case of medical emergency;
- photo-finish and time-keeping installations
- public announcement facilities and announcers.

(text modified on 1.01.05).

§ 3 Specific regulations

1.2.040 The organiser shall draw up a set of regulations specific to his race.

The regulations shall inter alia cover sporting aspects particular to the race.

These specific regulations shall comply fully with the present regulations and have been approved beforehand by the national federation of the organiser.

1.2.041 (N) The specific regulations shall be published in the programme and/or the technical guide for the race.

§ 4 Programme - technical guide

1.2.042 (N) The organiser shall prepare a programme and/or technical guide for his race, which must be approved in advance by his national federation.

The contents shall be determined by the provisions governing the various disciplines.

It shall, at least, be written in French or English; other languages may be added.

- 1.2.043** With the exception of minor alterations to the timetable for the competition, provisions once published in the programme and/or technical guide can no longer be altered save with the agreement of all concerned or where it is necessary to bring them into line with the regulations.

The organiser may, if necessary, make a substantial change to the timetable for the event subject to the following conditions:

- 1) he must notify the teams or riders and the international commissaires at least 15 days in advance;
- 2) he must repay the teams or riders, commissaires, national federations and the UCI any irrecoverable costs caused by the change to the timetable.

(text modified on 1.01.04).

- 1.2.044** Any breach of the provisions relating to the programme or technical guide shall render the organiser liable to a fine of between 500 and 2000 Swiss francs.

- 1.2.045** The organiser shall send the programme and/or technical guide to all teams or riders invited to participate in the race, at the latest when they confirm their enrolment.

The organiser shall send the programme and/or technical guide to the international commissaire(s) 30 days before the date of the race.

- 1.2.046** At the team managers' meeting, the organiser shall provide a sufficient number of copies of the programme and/or technical guide of the race for distribution to the riders.

- 1.2.047** By participating in a race, a rider shall be assumed to know and to have accepted the content of the programme and/or technical guide, including the specific race regulations.

§ 5 Invitation - Enrolment

General principle

- 1.2.048** (N) Unless otherwise specified, the organiser is free to select any teams and riders for an event, without any requirement to take account of any national protection.

Without prejudice to the provision concerning Mountain bike, BMX and the Masters category, organisers of events on the international calendar may not require any form of contribution from riders and/or teams (contribution to costs, entry fee, etc.).

(text modified on 1.01.02; 1.01.04; 1.01.05; 23.09.05).

Conditions

1.2.049 The organiser shall, at least 60 days in advance, invite the team or rider by sending general information. In the case of national, regional or club teams, he shall notify the national federation of the invitation.

At least forty days before the race, an invited party shall inform the organiser in writing (letter, fax) whether he/it wishes to participate in the race or whether he/it wishes to decline the invitation.

At least thirty days before the race, the organiser shall send an official UCI entry form to all invited parties whose participation he accepts. At the same time, he shall inform invited parties whose participation he does not accept to that effect.

At least twenty days before the race, the invited party shall return to the organiser the original and three copies of the duly completed entry form. The organiser shall keep the original of the form and shall, within 48 hours of its reception, send the three other copies to each of addresses mentioned thereon.

72 hours before the event's start time, the teams must fax the organiser a copy of the entry form giving the names of the entrants plus two reserves.

Any party failing to meet the prescribed deadlines shall forfeit its rights.

(text modified on 1.01.01; 1.01.03; 1.01.04; 1.01.05).

1.2.050 The organiser shall submit the entry forms to the commissaires' commission for verification.

General provisions

1.2.051 In a national calendar race, the entry procedures shall be determined by the national federation of the organiser.

1.2.052 National, regional and club teams and their respective riders may not start in competitions abroad unless they hold authorisation in writing issued by their federation (except teams and riders from the same federation as the event organiser). This authorisation must carry the dates of validity and the name(s) of the rider(s) concerned.

The provisions in this article shall not apply to riders covered by the provisions of article 2.1.010.

(text modified on 1.01.01; 1.01.04; 1.01.05).

1.2.053 In the event that a UCI registered team or rider belonging to such a team is entered but fails to appear, the signatory of the entry and the team that he represents shall be jointly and severally liable to pay the organiser an indemnity equal to twice the travel and subsistence expenses agreed in writing.

In other cases of failure to start, the signatory of the entry and the team which he represents shall be jointly and severally liable to pay the organiser a penalty charge equal to the travel and subsistence expenses agreed in writing.

(text modified on 1.01.02; 1.01.04; 1.01.05).

1.2.054 The organiser may not accept late entries. The organiser must inform the signatory of the entry in question of this. The president of the commissaires' panel shall rule in the event of dispute.

The organiser may not refuse to allow a team or a rider entered to start. He must submit his objections to the commissaires' panel which shall decide.

Should the organiser refuse without valid reason to allow an entered team to start in an event of road class HC or 1, the organiser must pay the team an indemnity equal to double the total sum of the allowances for the event.

(text modified on 1.01.02; 1.01.05).

Penalties

1.2.055 The following infringements shall be penalised as indicated below:

1. Rider contracted (identification number issued) absent at the start:
 - if not participating in any other event: a 50 Swiss francs fine;
 - if participating in another event: exclusion from the classification and a fine of between 500 and 3000 Swiss francs.
2. Failure on the part of the organiser to use the official entry form:
 - fine of between 300 and 1000 Swiss francs per team.

(text modified on 1.01.05).

§ 6

Race headquarters - Secretarial office

1.2.056 (N) The organiser shall provide a fully equipped secretarial office for the full duration of the race. A representative of the organiser must be present there at all times.

(article introduced on 1.01.05).

1.2.057 (N) This race headquarters will be set up at the competition venue. For road races, the race headquarters will be operational at the start location during the two hours that precede the start of the race, as well as at the finish location, during the two hours that precede the finish of the race.

1.2.058 (N) The race headquarters at the finish will remain open until the results are sent to the UCI, or, if the commissaires have not completed their work at that juncture, until such time as that work has been completed.

(article introduced on 1.01.05).

- 1.2.059** (N) The race headquarters must be provided with at least a telephone line, a fax and a computer with internet access.

(article introduced on 1.01.05).

§ 7 Course and safety

Safety

- 1.2.060** The organiser must provide an adequate security service and organise efficient cooperation with the police.

(article introduced on 1.01.05).

- 1.2.061** Without prejudice to the relevant legal and administrative provisions and the general duty of care, the organiser shall ensure that the race course or the competition grounds include no places or situations that could constitute a particular safety risk to anyone (riders, attendants, officials, spectators, etc.).

(text modified on 1.01.05).

- 1.2.062** Without prejudice to provisions requiring an entirely closed circuit, all traffic shall be stopped on the course as the race passes through.

- 1.2.063** In no case can the UCI be held responsible for defects in the course or installations of for any accidents that may occur.

(text modified on 1.01.05).

- 1.2.064** Riders shall study the course in advance.

Unless ordered so to do by a police officer, they may not leave the prescribed course and shall not be able to claim any error in this respect, nor any other motive such as, for example, incorrect directions by any person, badly placed or non-existent signs, etc.

Conversely, should the rider take a shortcut giving an advantage, **he shall be penalised in accordance with article 12.1.040.15**, notwithstanding any other disciplinary measures that may be provided for.

(text modified on 1.01.07).

- 1.2.065** If one or more riders leave the circuit on the orders of a police officer, they will not be punished. If that detour gives an advantage, the riders concerned shall wait when they return to the normal course and then restart in the positions they occupied before the detour.

If all or some of the riders take the wrong route, the organiser shall do all he can to direct the riders back to the course at the place where they left it.

§ 8 Medical service

1.2.066 The organiser shall set up an adequate medical service.

1.2.067 The organiser shall appoint one or more doctors to provide riders with medical care.

1.2.068 Facilities for rapid transfer to hospital must be available. At least one ambulance shall follow the competition or be available at the competition venue.

Prior to the start of the event, the organiser must make available to starting teams a list of the hospitals contacted to handle any injuries.

(text modified on 1.01.98; 1.01.05).

§ 9 Prizes

1.2.069 All information on prizes (number, nature, amount, conditions of awarding) shall be clearly stated in the programme or technical guide of the race.

1.2.070 The management committee may set minimum prize levels for events on the international calendar. For UCI ProTour events, the total minimum prize value is determined by the UCI ProTour Council.

(text modified on 2.03.00; 1.01.05).

1.2.071 No more than 30 days before the race, the organiser shall pay over to his national federation a sum covering the total value of the prizes. The national federation shall ensure that they be distributed. The payment may be replaced by a bank guarantee; in this case the prizes shall be paid out by the organiser.

1.2.072 Prizes shall be paid to the beneficiaries or their representatives no later than 90 days after the finish of the race.

1.2.073 If it there is any dispute that might influence placing and hence entitlement to a prize, the prize shall be withheld until a decision has been reached.

Unless specially provided otherwise, the following riders in the classification shall each advance by one place and shall be entitled to the prizes corresponding to their new places. Should a rider or a team lose the place that entitled him or them to a prize, the prize must be returned within one month. In the event of non-compliance, the total amount repayable shall be increased automatically by 20% (twenty percent) and the organiser may refer the matter to the UCI. The rider or team shall be suspended automatically if the prize, increased by 20% (twenty percent), has not been repaid to the UCI within one month of notice being given by the UCI until such time as the total amount due has been repaid.

The last paragraph applies also to any intermediary or beneficiary in possession of the prize as from the moment that the request for repayment is made.

(text modified on 1.01.05; 1.10.05).

- 1.2.074** If a race or a stage is ridden at an abnormally low average speed, the commissaires' panel may, after consulting the organiser, decide to reduce or cancel prizes.

§ 10

Travel and subsistence expenses

- 1.2.075** 1. Without prejudice to the provisions below, the contribution made by the organiser to the travel and subsistence expenses of the teams or riders in an event on the international calendar shall be negotiated directly between the parties.

The subsistence allowance shall include accommodation, meals and drinks during the event.

2. For certain events, the management committee or the UCI ProTour Council may oblige the organisers to pay a participation allowance and fix the minimum amount of the allowance. The participation allowances shall be deemed to cover travel expenses.

(text modified on 1.01.02; 1.01.03; 1.01.05; 1.01.06).

- 1.2.076** The allowance due will be paid no later than the end of the event.

For races of 4 days or more, the agreed allowance shall be paid as follows:

- one third at the end of the team managers' meeting;
- one third half way through the competition;
- the balance on the eve of the last day.

(text modified on 1.01.05).

Section 3: race procedures

(numbering of articles modified on 1.01.05).

§ 1 Supervision of the organisation and competition

1.2.077 The material administration of the race shall be assumed by the organiser or his representative. Purely material organisational problems shall be solved by race administration in accordance with applicable regulations and after consulting the commissaires' panel.

1.2.078 The president of the commissaires' panel, together with the other commissaires, shall take on the sporting administration and supervision of the competition.

(text modified on 1.01.05).

§ 2 Conduct of participants in cycling races

1.2.079 All licence holders shall at all times be properly dressed and behave correctly in all circumstances, even when not racing.

They shall refrain from any acts of violence, threats or insults or any other improper behaviour or from putting other persons in danger.

They may not in word, gesture, writing or otherwise harm the reputation or question the honour of other licence holders, officials, sponsors, federations, the UCI or cycling in general. The right of criticism shall be exercised in a motivated and reasonable manner and with moderation.

1.2.080 All licence holders shall, in whatever capacity, participate in cycling races in a sporting and fair manner. They shall look to contributing fairly to the sporting success of the race.

1.2.081 Riders shall sportingly defend their own chances.
Any collusion or behaviour likely to falsify or go against the interests of the competition shall be forbidden.

1.2.082 Riders shall act with utmost caution. They shall be held responsible for any accidents that they cause.

They shall, in the way they behave in the race, observe the legislation of the country where the race takes place.

1.2.083 Carrying and using glass containers shall be forbidden during competitions.

§ 3 Team manager

1.2.084 During events, each team, except regional and club teams, shall be managed by a team manager appointed for this purpose.

(text modified on 1.01.99; 1.01.05).

1.2.085 The team manager shall ensure that the riders of his team attend at the required times and places (signing on, start line, antidoping control, etc.).

He shall respond when summoned by the president of the commissaires' panel or by the organisation's management.

(text modified on 1.01.99).

1.2.086 The team manager may represent the riders before the commissaires' panel.

§ 4 Team managers' meeting

1.2.087 No more than 24 hours and no less than 2 hours before the start of the competition, the organiser must convene a meeting in a suitable room with the representatives of the organisation, the team managers, the commissaires and, where appropriate, the persons responsible for neutral vehicles and the services of public order, to coordinate their respective tasks and to take note of the specific characteristics of the event and safety measures as concern their own fields.

In UCI ProTour events and events in classes HC and 1 for Elite men and women's world cup events, this meeting must be held at the following times:

- event starting before 12:00: the evening before at 17:00;
- event starting after 12:00: at 10:00 on the day of the race.

For world cup cyclo-cross events, the meeting must take place the day prior to the start of competition.

For mountain bike events at the world championships, World Cups, continental championships, hors classe stage races and class 1 stage races, the meeting must take place the day before the start of competitions.

(text modified on 1.1.04; 1.01.05; 1.01.06).

1.2.088 At the meeting, the commissaires shall reiterate the applicable provisions of the regulations, especially those relating to the specific characteristics of the race. The organiser shall announce any specific legal provisions that may be applicable, e.g. in connection with doping.

The meeting shall take the form determined for that purpose by the UCI.

(text modified on 1.1.04; 1.01.05).

§ 5 **Entry check**

- 1.2.089** The organiser shall provide the commissaires' panel in due time with a list of riders who have entered for the race and who have been confirmed as titular riders or reserve riders (entry list).

(text modified on 1.01.02).

- 1.2.090** Before the team managers' meeting as per article 1.2.087, the team manager - or his representative - must confirm the identity of the riders who will be starting to the commissaires' panel. The commissaires' panel shall check the licences of these riders and ensure that they are included on the list of entrants.

Riders confirmed as starters can no longer be substituted.

The commissaires' panel shall also check authorisations to participate from the national federation required under article 1.2.052.

The operations above must be organised such that they are completed at the latest by 15 minutes before the team managers' meeting.

(text modified on 1.01.02; 1.01.04; 1.01.05).

- 1.2.091** A rider whose licence has been checked shall receive his identification number(s).

(text modified on 1.01.04; 1.01.05).

- 1.2.092** A rider whose licence could not be verified and whose status as a non-suspended licence holder can not be established in any other manner may not start and may not figure in the classification of the event.

(text modified on 1.01.05).

- 1.2.093** The licence check shall take place in an area of sufficient size and which is inaccessible to the public.

§ 6 **Start of the race**

- 1.2.094** For road races and cyclo-cross events, the riders must sign the signature sheet under the supervision of a commissaire prior to the start.

(text modified on 1.01.04; 1.01.05).

- 1.2.095** The start shall be given by means of a pistol, a whistle, a bell, a flag or by electronic means.
- 1.2.096** The start shall be given by — or under the control of — a commissaire (the starter) and he alone shall judge the validity of the start.
- 1.2.097** A false start shall be indicated by a double pistol shot, a double-whistle or a double bell-chime.
- 1.2.098** The commissaires shall verify that riders present on the start line are equipped according to the regulations (bicycle, clothing, identification numbers, etc.)

(text modified on 1.01.05).

§ 7 Finish

Finish line

- 1.2.099** The finish line shall comprise a line of 4 cm in width, painted in black on a white strip 72 cm wide thus leaving 34 cm of white on each side of the black line. For mountain bike races the white strip must be 20 cm, thus leaving 8 cm on each side of the black line.

(text modified on 1.01.04; 1.01.05).

- 1.2.100** The finish occurs at the instant that the tyre of the front wheel meets the vertical plane rising from the starting edge of the finishing line. To this end, the verdict of the photo-finish shall be final.

Unless otherwise specified, the finish may also be observed using any appropriate technical means that is accepted by the commissaires' panel.

(text modified on 1.01.00; 1.01.04; 1.09.04; 1.01.05).

- 1.2.101** In road, mountain bike, BMX and cyclo-cross events, a banner labelled "FINISH" must be fixed above the finishing line and perpendicular to the road or course. Should the banner have disappeared or been damaged, the finish line shall be indicated by a black and white chequered flag. Such a flag shall also be used for any finish or for the passing of any intermediate point for a classification as well as at the top of mountain passes during road races.

(text modified on 1.01.05).

- 1.2.102** (N) A photo-finish with electronic timing strip **is required for the following events:**
- **road races**
 - **track races**
 - **Olympic Games, world championships and world cup mountain bike events**
 - **BMX races.**

For cyclo-cross world cup events, only a photo-finish is obligatory.

(text modified on 1.01.04; 1.01.05; 1.01.06).

- 1.2.103** The film, the electronic timing strip and any other medium on which the finish is recorded shall be deemed to be valid documents. They may be consulted by all parties concerned if the finishing order should be disputed.

(text modified on 1.01.05).

Time-keeping

- 1.2.104** For each race, the national federation of the organiser shall designate a sufficient number of time-keeper-commissaires duly licensed by it. Timekeeper-commissaires may be helped in matters other than time-keeping operations proper by other persons licensed by the national federation of the organiser.

(text modified on 1.01.05).

- 1.2.105** Timekeeper-commissaires shall record the times on a form that they shall sign and hand to the finishing judge.

(text modified on 1.01.05).

- 1.2.106** Times shall be taken using an electronic time-keeping machine.

In track races and mountain bike downhill races, times shall be taken to the nearest 1000th of a second.

In other races, the times shall be taken to the nearest second at least. Results shall be communicated to the second.

Moreover manual time-keeping will be undertaken whenever deemed necessary or useful.

- 1.2.107** When several riders finish in a group, all riders in the same group shall be credited with the same time. After each gap the timekeeper-commissaires shall record a new time. This time is taken on the first rider of the group.

(text modified on 1.01.05).

Classification

- 1.2.108** Unless otherwise stated, each rider shall, in order to be classified, complete the race entirely through his own effort, without the assistance of any other person.

- 1.2.109** The rider may cross the finish line on foot, provided that has his bicycle with him.

(text modified on 1.01.05).

- 1.2.110** The finishing order, the number of points won and the number of laps ridden shall be recorded by the finish line-commissaire. If need be, the classification shall be established using the technical resources available.

(text modified on 1.01.05).

- 1.2.111** Without prejudice to any changes resulting from the application of the regulations by the competent bodies, the classification of the race may be corrected by the organiser's national federation within 30 days of the end of the race in the event of material errors in the recording of the riders' finishing order.

The organiser's national federation shall notify the organiser and all riders involved of any such correction, if necessary through their team. For races on the international calendar, it shall also notify the UCI. The organiser's national federation shall also ensure that any issues resulting from the correction of the classification shall be resolved correctly.

(text modified on 1.01.98; 1.01.05).

§ 8**Awards ceremony**

- 1.2.112** All riders concerned shall, in accordance with their placing, classifications and performances, participate in official ceremonies such as the presentation of jerseys, bouquets or medals, laps of honour, press conference and the like.

- 1.2.113** Unless otherwise stated, riders shall appear at official ceremonies wearing competition clothing.

(text modified on 1.01.05).

Section 4: supervision of races

(numeration of the articles modified on 1.01.05).

§ 1**General provision**

- 1.2.114** The supervision of races on national calendars shall be regulated by the national federation of the organiser.

The supervision of races on the international calendar shall be regulated by the present section.

(text modified on 1.01.05).

§ 2 Commissaires' panel**Task and composition**

1.2.115 The proceedings at cycling races shall be supervised by a commissaires' panel.

The organiser shall take particular care to ensure that the commissaires may work in optimum conditions.

1.2.116 The commissaires' panel shall comprise an odd number of commissaires.

The number and status of the commissaires to be appointed for each race shall be as indicated in the following table:

(text modified on 1.01.05).

ROAD RACES

Position and status	Appointed by	Riders of all categories					Riders with a disability		
		Olympic Games (1)	World Championships	Juniors World Championships & B World Championships (2)	Continental Championships & Regional Games	Masters World Championships	Paralympics Games, World Championships, Regional Games		
President of the commissaires' panel, UCI international commissaire	UCI	1	1	1	1	1			1
	NF	-	-	-	-	-			-
Member of the commissaires' panel, international commissaire UCI	UCI	4	6	5	-	-			-
	NF	-	-	-	-	2			-
Member of the commissaires' panel, UCI international or national commissaire	NF	-	-	-	-	-			-
	NF	10*	8	10	*	10*			-

ROAD RACES

Position and status	Appointed by	UCI Pro Tour				Elite Men's continental circuits			Elite Women		Juniors Men & Women	
		One-day races	Stage races	Grands Tours	Hors classe	1	2	World Cup	1	2	HC	1
President of the commissaires' panel, UCI international commissaire	UCI	1	1	1	1	1	2	1	1	1	1	1
Member of the commissaires' panel, international commissaire UCI	NF UCI	- 2	- 2	- 3	- -	- -	- -	- -	- -	1 -	- -	1 -
Member of the commissaires' panel, UCI international or national commissaire	NF NF	- -	- -	- -	2 -	2 -	- 2	2 -	2 -	- 2	- 2	- 2
Additional commissaires officiating in cars or on motorcycles	NF	3	2-4*	3-6*	2-6*	2-6*	0-2*	2-6*	1-3*	0-2*	0-2*	0-2*

* Depending on the number of participants and the nature of the course

- (1) Commissaires appointed for track, mountain bike and BMX events shall officiate as assistants at road events.
- (2) For road and track disciplines

CYCLO-CROSS EVENTS

Position and status	Appointed by	World championships	Masters World championships	World Cup	Cat. 1	Cat. 2
President of the commissaires' panel, UCI international commissaire	UCI	1	1	1	1	
President of the commissaires' panel, national commissaire	NF					1*
Member of the commissaires' panel (minimum number), UCI international commissaire	UCI	4				
Member of the commissaires' panel (minimum number), national commissaire	NF		2	2	1*	
Member of the commissaires' panel (minimum number), national commissaire	NF				1	2
Additional commissaires, UCI international or national commissaires	NF	4	3			

* of the nationality of the organising country

TRACK EVENTS

Position and status	Appointed by	Olympic games (1)	World Championships	Juniors World Championships	B World Championships	Masters World Championships	Continental Championships and Regional games	World Championships + Regional Championships for riders with a disability + Paralympics Games	World Cup	Cat. 1	Cat. 2	Cat. 3	Six days	Other events
President of the commissaires' panel, UCI international commissaire	UCI	1	1	1	1	1	1	1	1	1	1	1	1	
	NF													1
President of the commissaires' panel, national commissaire	NF													
	UCI	1	1	1	1	1		1						
Secretary of the commissaires' panel, UCI international commissaire	NF													
	NF					1								
Secretary of the commissaires' panel, national commissaire	UCI	1	1	1	1	1			1					
	NF													
Starter, UCI international commissaire	UCI	1	1	1	1	1			1					
	NF													
Starter, national commissaire	NF													
	NF													

Position and status	Appointed by	Olympic games (1)	World Championships	Juniors World Championships	B World Championships	Masters World Championships	Continental Championships and Regional games	World Championships + Regional Championships for riders with a disability + Paralympics Games	World Cup	Cat. 1	Cat. 2	Cat. 3	Six days	Other events
Referee, UCI international commissaire	UCI	1	1	1	1			1						
	NF					1	1							
Referee, national commissaire	NF													
Member of the commissaires' panel (minimum number), UCI international commissaire	UCI	1	3	1	1									
	NF													
Member of the commissaires' panel (minimum number), national commissaire	NF									2	1	1	2	2
	NF						2	10		6	6	6	4	4
Additional commissaires, UCI international or national commissaires	NF	10	12	10	10	10								

(1) The commissaires appointed for road, mountain bike and BMX events may officiate as assistants at track events.

MOUNTAIN BIKE EVENTS

Position and status	Appointed by	Olympic Games (1)	World Championships	World Marathon Championships	Masters World Championships	Continental Championships * Regional Games	World Cup	DHc	D1	D2	EHc	E1	E2	E3	E4
President of the commissaires' panel, UCI international commissaire	UCI	1	1	1	1*	1	1	1*	1	1	1	1	1	1	1
	NF														
President of the commissaires' panel, national commissaire	NF														
	UCI	1	1*	1*			1								
Assistant president of the commissaires' panel, UCI international commissaire	NF														
	NF														
Assistant president of the commissaires' panel, national commissaire	UCI	1	1*	1*											
	NF														
Secretary of the commissaires' panel, UCI international commissaires	UCI	1	1*	1*											1
	NF				1	1	1	1	1						
Secretary of the commissaires' panel, national commissaire	NF														

Position and status	Appointed by	Olympic Games (1)	World Championships	World Marathon Championships	Masters World Championships	Continental Championships * Regional Games	World Cup	DHc	D1	D2	Etc	E1	E2	E3	E4
Start line commissaire (XC), UCI international commissaire	UCI	1	1 *3	1 *3											
	NF				1	1	1								
Start line commissaire (XC), national commissaire	NF							1	1			1			
	UCI		1 *3	1 *3											
Start line commissaire (DH), UCI international commissaire	NF				1	1	1								
	NF														
Start line commissaire (DH), national commissaire	UCI	1	1 *3	1 *3											
	NF				1	1	1								
Finish line commissaire, UCI international commissaire	UCI														
	NF				1	1	1								
Finish line commissaire, national commissaire	NF							1	1	1	1	1			
	NF	10*	8	8	8	4	4	3	2	2	3	2	2	2	1

(1) The commissaires appointed for road, track and BMX events may officiate as assistants at mountain bike events.

* Depending on the number of participants and the nature of the course

*1 – coming from a continent other than that of the organiser

*2 – coming, when possible, from the host country

*3 – coming from a country other than that of the organiser

TRIALS EVENTS

Position and status	Appointed by	World Championships	World Cup	Other events
President of the commissaires' panel, UCI international commissaire	UCI	1	1	
Zone commissaire, UCI international commissaire	UCI	7	5	
Zone commissaire, national commissaire	NF	8	6	

(text introduced on 1.01.04).

BMX EVENTS

Position and status	Appointed by	Olympic Games (1)	World Championships	BMX Supercross	Continental races	Other events
President of the commissaires' panel, UCI international commissaires	UCI	1	1	1		
	NF				1	
Assistant president of the commissaires' panel, UCI international commissaires	UCI	1	1	1		
	NF					
Administrative commissaire, UCI international commissaire	UCI	1	1	1		
	NF					
Assistant administrative Commissaire, UCI international Commissaire	UCI	1	1			
	NF					
Third Commissaire, UCI international Commissaire	UCI			1		
	NF					
Stager commissaire, UCI international commissaire	UCI					
	NF	1	1	1	1	1

Position and status	Appointed by	Olympic Games (1)	World Championships	BMX Supercross	Continental races	Other events
Finish line commissaire, UCI international commissaire	UCI					
	NF	1	1	1		
Additional commissaires, UCI international or national commissaires	NF	10*	8*	2*		

(1) The commissaires appointed for road, track and mountain bike events may officiate as assistants at BMX events.

* Depending on the number of participants and the nature of the course

(text introduced on 1.01.04; modified on 1.01.06).

INDOOR CYCLING EVENTS

Position and status	Appointed by	Cycle-ball World Championships	Artistic Cycling World Championships	Cycle-ball World Cup	Cycle-ball class A events	Artistic Cycling class A events	Cycle-ball class B events	Artistic Cycling class B events	Other events
President of the commissaires' panel, UCI international commissaire	UCI	1	1	1					
	NF				1	1			
President of the commissaires' panel, UCI international or national commissaire	NF						1	1	
	UCI	6	5	3					
Member of the commissaires' panel, UCI international or national commissaire	NF								
	NF				2*	4*	1	2	
Member of the commissaires' panel, UCI international or national commissaire									

*coming from 2 different nations
(text modified on 1.01.05).

- 1.2.117** (N) The commissaires' panel shall be assisted by timekeeper-commissaire- and a commissaire-secretary, appointed and licensed by the national federation of the organiser.

(text modified on 1.01.05).

President of the commissaires' panel

- 1.2.118** The president of the commissaires' panel shall be appointed by the national federation of the organiser or by the UCI, as appropriate.

The president of the commissaires' panel or a commissaire appointed by him shall act as competition director.

(text modified on 1.01.05).

Finish line commissaire

- 1.2.119** One of the members of the commissaires' panel shall act as finish line-commissaire.

The finish line commissaire may, on his own responsibility, co-opt other persons appointed and licensed by the national federation of the organiser to assist him.

(text modified on 1.01.05).

- 1.2.120** The finish line commissaire shall be the sole judge of the finish. He shall, on a special form that he shall sign and hand in to the president of the commissaires' panel, note the finishing order, the number of points won and the number of laps covered.

(text modified on 1.01.00; 1.01.05).

- 1.2.121** (N) The finish line commissaire shall be provided with a raised and sheltered podium level with the finish line.

Meeting

- 1.2.122** The commissaires' panel shall meet before the start of each race. Its members shall also attend the meeting with the organiser and team managers.

Report

- 1.2.123** (N) The commissaires' panel shall draw up a detailed report on the event using the form provided for this purpose by the UCI. This report must be accompanied by the following documents:

- list of entered riders
- list of riders taking the start
- the classification(s)
- a copy of the technical guide

The timekeeper-commissaire's sheets and reports by individual commissaires shall be appended thereto. A copy of the report shall be sent to the national federation of the organiser so that the competition may be approved.

(text modified on 1.01.05).

- 1.2.124** UCI international commissaires have, furthermore, to provide a detailed report on the form provided for that purpose, giving their evaluation of the race, and to send it to the UCI in a maximum of 14 days. They must also use e-mail - or any other method specified by the UCI - to send the complete result of the event to the UCI, at the earliest opportunity and within 2 hours at the latest.

(text modified on 1.01.04; 1.01.05).

Expenses

- 1.2.125** Commissaires shall be entitled to reimbursement of their expenses. Except in the case of international commissaires appointed by the UCI to sit on the commissaires' panel, the amounts and modes of payment shall be determined by the national federation of the organiser.

§ 3

Powers of the commissaires' panel

- 1.2.126** The commissaires' panel shall verify that the specific race regulations comply with the present regulations. It shall rectify or have rectified any provisions that do not comply and shall mention that fact during the meeting with the organiser and team managers.
- 1.2.127** The commissaires' panel shall have any irregularity it may observe in the organisation of the race rectified.
- 1.2.128** The commissaires shall note infringements and impose penalties in matters within their authority. Each commissaire shall individually observe infringements and note them in a report bearing his signature. Commissaires' reports shall constitute conclusive evidence of the facts they observe, in the absence of proof to the contrary.

Penalties shall be imposed by the commissaires' panel by a majority vote.

- 1.2.129** Moreover each of the commissaires shall be individually entitled to take the following measures:
1. to refuse to allow riders to start who do not comply with the regulations or who are manifestly not in any condition to participate in the race;
 2. to give warnings and to inflict an admonition;
 3. to immediately remove from the competition a rider who commits a serious fault, who is manifestly not in any condition to continue the competition, who has dropped so far behind as not to be able to catch up again or who constitutes a danger to other persons.

Such decisions shall be set down in a signed report.

(text modified on 1.01.00; 1.01.05).

1.2.130 The commissaires' panel or, if necessary, each individual commissaire, shall take all decisions that may be required to ensure the proper conduct of the race. Those decisions shall be taken in keeping with the applicable provisions of the regulations and, to the extent of the possible, after consulting the race administration.

1.2.131 Licence holders who do not follow the instructions of commissaires shall be penalised by a suspension of between one day and six months and/or by a fine of 100 to 10 000 Swiss francs.

1.2.132 Without prejudice to article 12.1.012 on disciplinary matters, no appeal shall be admitted against observations of fact, assessments of the situation in races and application of the competition regulations by the commissaires' panel or, where appropriate, an individual commissaire, or against any other decision taken by them.

(text modified on 1.01.00; 1.01.05).

Section 5: UCI cups, series and classification

1.2.133 Is left out from any UCI classification as well as from any UCI cups and series classifications:

1. the suspended rider: in case of suspension until the last event counting for the ranking, the rider is immediately excluded from the classification.
2. the rider against whom the anti-doping commission, after the review described in articles 184 to 206 of the anti-doping rules, asserts that an anti-doping violation was committed, **from the date when the rider's identity has been publicly announced**, until his definitive acquittal. The place of the rider in the classification is left vacant, except where the above paragraph or the article below applies.

(text modified on 1.09.05; 19.09.06).

1.2.134 The rider found guilty of an anti-doping violation is excluded from each classification which is calculated over a period in which the violation occurred.

(article introduced on 1.09.05).

**Chapter EQUIPMENT**

(sections 1 and 2 introduced on 1.01.00).

Section 1: general provisions**§ 1 Principles**

- 1.3.001** Each licence holder shall ensure that his equipment (bicycle with accessories and other devices fitted, headgear, clothing, etc.) does not, by virtue of its quality, materials or design, constitute any danger to himself or to others.
- 1.3.002** The UCI shall not be liable for any consequences deriving from the choice of the equipment used by licence holders, nor for any defects it may have or its non-compliance.
- 1.3.003** In no event shall the fact that a rider has been able to take part in the competition give rise to liability on the part of the UCI; checks on equipment that may be carried out by the commissaires or by an agent or a body of the UCI being limited to the compliance of the overall external appearance for purely sporting purposes.

(text modified on 1.01.05).

§ 2 Technical innovations

- 1.3.004** Except in mountain bike racing, no technical innovation regarding anything used, worn or carried by any rider or license holder during a competition (bicycles, equipment mounted on them, accessories, helmets, clothing, means of communication, etc.) may be used until approved by the UCI executive bureau. Requests for approval shall be submitted to the UCI before June 30th of any year, accompanied by all necessary documentation. If accepted, the innovation shall be permitted only as from January 1st of the following year.

Acceptance shall refer solely to the fact that the innovation will be acceptable from a sporting point of view.

There is no technical innovation in the sense of the present article if the innovation entirely falls within the specifications foreseen in the regulations.

(text modified on 1.01.02; 1.01.04; 1.01.05).

1.3.005 If at the start of a competition or stage the commissaires' panel considers that a rider arrives with a technical innovation not yet accepted by the UCI, it shall refuse to permit the rider to start with such an innovation.

In the event of use in competition, the rider shall automatically be expelled from the competition or disqualified. There shall be no right to appeal against the decision of the commissaire's panel.

If this technical innovation is not noticed or sanctioned by the commissaire's panel, the UCI disciplinary commission shall order the disqualification. The UCI shall refer to the disciplinary commission, either automatically or at the request of all interested. The disciplinary commission will only apply sanctions after having received the opinion of the equipment commission.

In out of competition situations, the UCI shall decide whether an item should be considered a technical innovation and whether the procedure provided for in article 1.3.004 is to be followed.

(text modified on 1.01.05).

Section 2: bicycles

Preamble

Bicycles shall comply with the spirit and principle of cycling as a sport. The spirit presupposes that cyclists will compete in competitions on an equal footing. The principle asserts the primacy of man over machine.

§ 1 Principles

Definition

1.3.006 The bicycle is a vehicle with two wheels of equal diameter. The front wheel shall be steerable; the rear wheel shall be driven through a system comprising pedals and a chain.

Type

1.3.007 Bicycles and their accessories shall be of a type that is or could be sold for use by anyone practising cycling as a sport. The use of equipment designed especially for the attainment of a particular performance (record or other) shall be not authorised.

Position

1.3.008 The rider shall normally assume a sitting position on the bicycle. This position requires that he be supported solely by the pedals, the saddle and the handlebars.

Steering

- 1.3.009** The bicycle should have handlebars which allow it to be ridden and manoeuvred in any circumstances and in complete safety.

Propulsion

- 1.3.010** The bicycle shall be propelled solely, through a chainset, by the legs (inferior muscular chain) moving in a circular movement, without electric or other assistance.

(text modified on 1.01.05).

§ 2 Technical specifications

Except where stated to the contrary, the following technical specifications shall apply to bicycles used in road, track and cyclo-cross racing.

The specific characteristics of bicycles used in mountain bike, BMX, trials, indoor cycling and cycling for riders with disabilities are set out in the part regulating the discipline in question.

(text modified on 1.01.05).

1.3.011 a) Measurements (see diagram «Measurements (1)»)

Measurements (1)

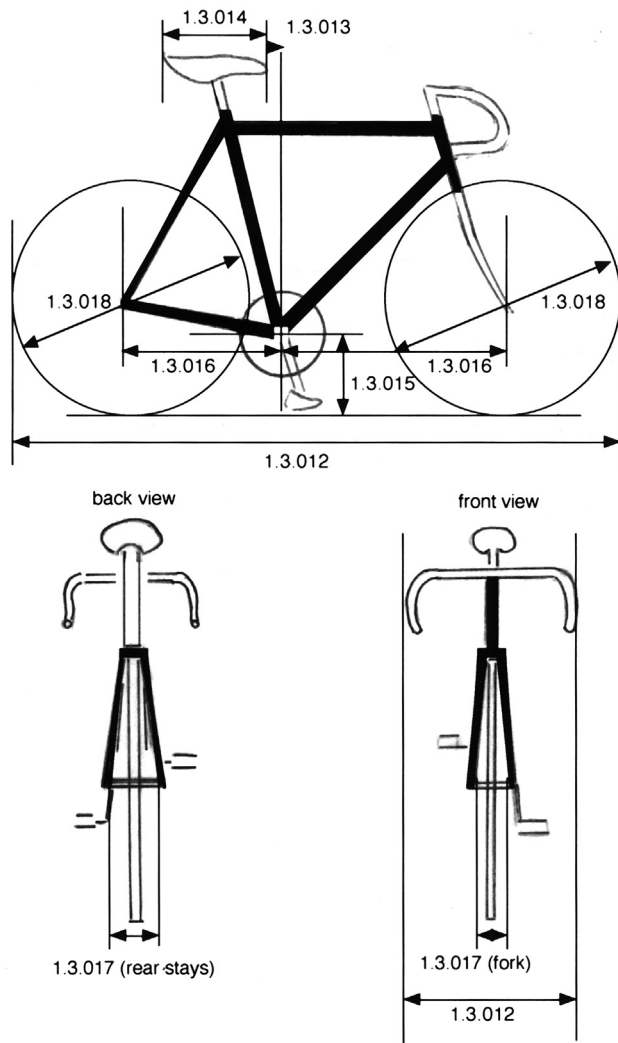

1.3.012 A bicycle shall not measure more than 185 cm in length and 50 cm in width overall.

A tandem shall not measure more than 270 cm in length and 50 cm in width overall.

1.3.013 The peak of the saddle shall be a minimum of 5 cm to the rear of a vertical plane passing through the bottom bracket spindle (1). This restriction shall not be applied to the bicycle ridden by a rider in a track sprint event, keirin, 500 metres or 1 kilometre time trials; however, in no circumstances shall the peak of the saddle extend in front of a vertical line passing through the bottom bracket spindle.

(1) The distances mentioned in footnote (1) to articles 1.3.013 and 1.3.016 above may be reduced where that is necessary for morphological reasons. By morphological reasons should be understood everything to do with the size and limb length of the rider.

Any rider who, for these reasons, considers that he needs to use a bicycle of lesser dimensions than those given shall inform the commissaires' panel to that effect when presenting his licence. In that case, the panel may conduct the following test. Using a plumb-line, they shall check to see whether, when pedalling, the point of the rider's knee when at its foremost position passes beyond a vertical line passing through the pedal spindle (see diagram «Measurements (2)»).

Measurements (2)

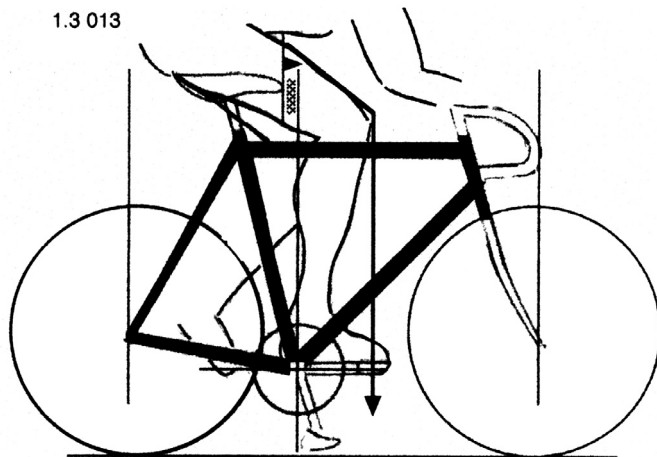

1.3.014 The saddle support shall be horizontal. The length of the saddle shall be 24 cm minimum and 30 cm maximum.

(text modified on 1.01.03).

1.3.015 The distance between the bottom bracket spindle and the ground shall be between 24 cm minimum and maximum 30 cm.

1.3.016 The distance between the vertical passing through the bottom bracket spindle and the front wheel spindle shall be between 54 cm minimum and 65 cm maximum ⁽¹⁾.

The distance between the vertical passing through the bottom bracket spindle and the rear wheel spindle shall be between 35 cm minimum and maximum 50 cm.

1.3.017 The distance between the internal extremities of the front forks shall not exceed 10.5 cm; the distance between the internal extremities of the rear triangle shall not exceed 13.5 cm.

1.3.018 Wheels of the bicycle may vary in diameter between 70 cm maximum and 55 cm minimum, including the tyre. For the cyclo-cross bicycle the width of the tyre shall not exceed 35 mm and it may not incorporate any form of spike or stud.

For massed start competitions in the disciplines road and cyclo-cross, only wheel designs granted prior approval by the UCI may be used. Wheels shall have at least 12 spokes; spokes can be round, flattened or oval, as far as no dimension of their sections exceeds 10 mm. In order to be granted approval wheels must have passed a rupture test as prescribed by the UCI in a laboratory approved by the UCI. The test results must show that the rupture characteristics obtained are compatible with those resulting from an impact sustained during normal use of the wheel. The following criteria must be fulfilled:

- On impact, no element of the wheel may become detached and be expelled outwards.
- The rupture must not present any shattered or broken off elements, or any sharp or serrated surfaces that could harm the user, other riders and/or third parties.
- The rupture characteristics must not cause the hub to become separated from the rim in such a way that the wheel becomes detached from the forks.

Without prejudice to the tests imposed by the laws, regulations or customs, standard (traditional) wheels are exempted from the rupture test referred to above. A traditional wheel is deemed to be a wheel with at least 16 metal spokes; the spokes may be round, flat or oval, provided that no dimension of their cross sections exceeds 2.4 mm; the section of the rim must not exceed 2.5 cm on each side.

Notwithstanding this article, the choice and use of wheels remains subject to articles 1.3.001 to 1.3.003.

(text modified on 1.01.02; 1.01.03; 1.09.03; 1.01.05).

1.3.019 b) Weight

The weight of the bicycle cannot be less than 6.8 kilograms.

1.3.020 c) Configuration

For road competitions other than time trials and for cyclo-cross competitions, the frame of the bicycle shall be of a traditional pattern, i.e. built around a main triangle. It shall be constructed of straight or tapered tubular elements (which may be round, oval, flattened, teardrop shaped or otherwise in cross-section) such that the form of each element encloses a straight line. The elements of the frame shall be laid out such that the joining points shall follow the following pattern: the top tube (1) connects the top of the head tube (2) to the top of the seat tube (4); the seat tube (from which the seat post shall extend) shall connect to the bottom bracket shell; the down tube (3) shall connect the bottom bracket shell to the bottom of the head tube. The rear triangles shall be formed by the chain stays (6), the seat stays (5) and the seat tube (4) with the seat stays anchored to the seat tube at points falling within the limits laid down for the slope of the top tube.

The maximum height of the elements shall be 8 cm and the minimum width 2.5 cm. The minimum width shall be reduced to 1 cm for the chain stays (6) and the seat stays (5). The minimum thickness of the elements of the front fork shall be 1 cm; these may be straight or curved (7). (See diagram «Shape (1)»).

The top tube may slope, provided that this element fits within a horizontal template defined by a maximum height of 16 cm and a minimum thickness of 2.5 cm.

(text modified on 7.06.00; 1.01.05).

Shape (1)

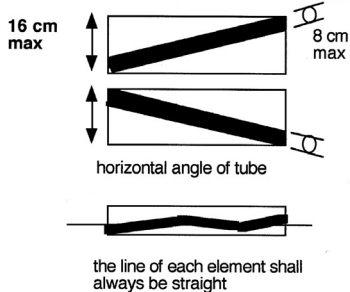
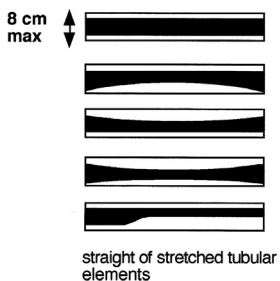
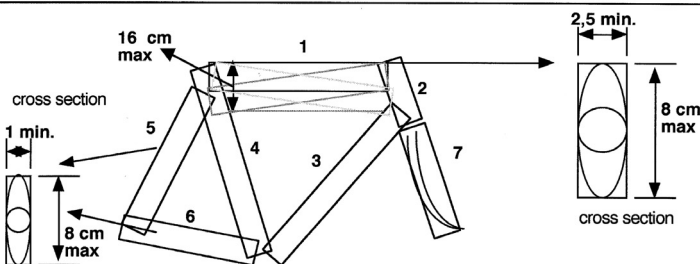
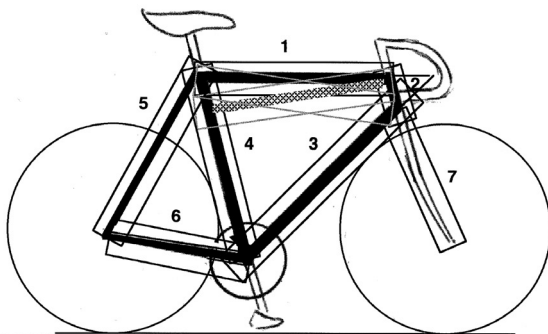

1.3.021 For road time trials and for track competitions, the elements of the bicycle frame may be tubular or solid, assembled or cast in a single piece in any form (including arches, cradles, beams or any other). These elements, including the bottom bracket shell, shall fit within a template of the «triangular form» defined in article 1.3.020. (See diagram «Shape (2)»).

(text modified on 7.06.00; 1.01.05).

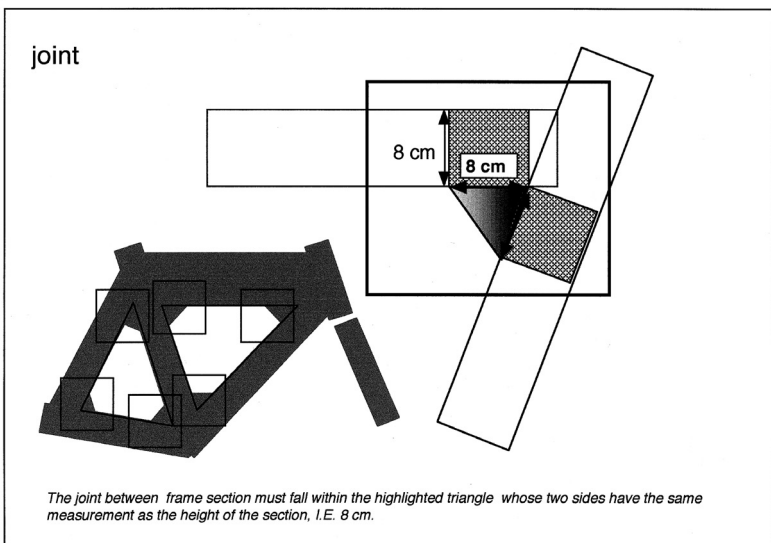
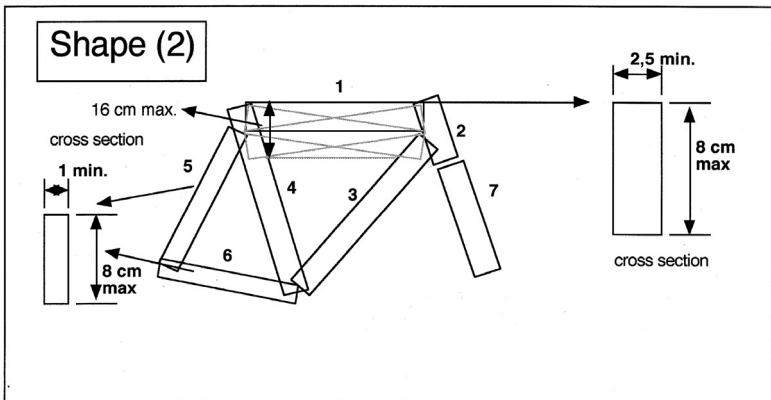

1.3.022 d) Structure

In competitions other than those covered by article 1.3.023, only the traditional type of handlebars (see diagram «structure 1») may be used. The point of support for the hands must be positioned in an area defined as follows: above, by the horizontal plane of the point of support of the saddle (B); below, by the horizontal line passing through the highest point of the two wheels (these being of equal diameter) (C); at the rear by the axis of the steerer tube (D) and at the front by a vertical line passing through the front wheel spindle with a 5 cm tolerance (see diagram «Structure (1A)»). The distance referred to in point (A) is not applicable to the bicycle of a rider who takes part in a sprint, keirin or olympic sprint race, but must not exceed 10 cm in relation to the vertical line passing through the front wheel spindle.

The brake controls attached to the handlebars shall consist of two supports with levers. It must be possible to operate the brakes by pulling on the levers with the hands on the lever supports. Any extension to or reconfiguration of the supports to enable an alternative use is prohibited. A combined system of brake and gear controls is authorised.

(text modified on 1.01.05).

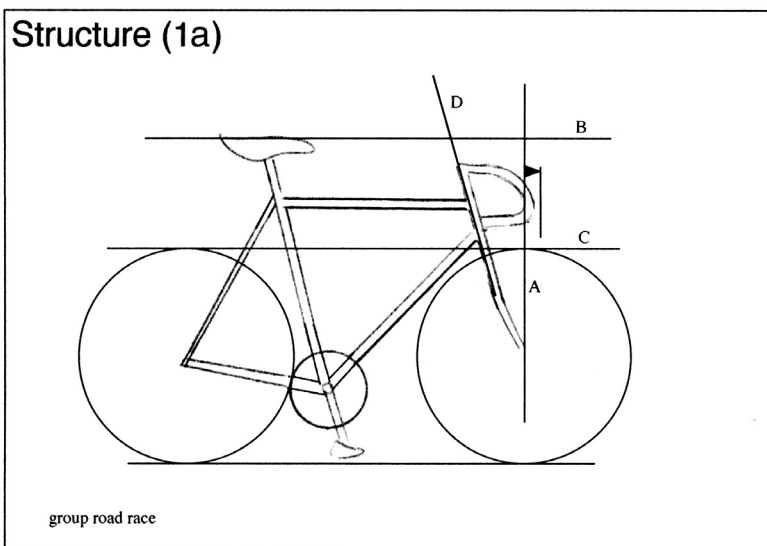

1.3.023 For road time trial competitions and for the following track competitions: individual and team pursuit, kilometre and 500 m, an extension may be added to the steering system. The distance between the vertical line passing through the bottom bracket axle and the extremity of the handlebar may not exceed 75 cm, with the other limits set in article 1.3.022 (B,C,D) remaining unchanged. A support for the elbows or forearms is permitted (see diagram «Structure (1B)»).

For road time trial competitions, controls or levers fixed to the handlebar extension may extend beyond the 75 cm limit as long as they do not constitute a change of use, particularly that of providing an alternative hand position beyond the 75 cm mark.

For the track and road competitions covered by the first paragraph, the distance of 75 cm may be increased to 80 cm to the extent that this is required for morphological reasons; «morphological reasons» should be taken as meaning anything regarding the size or length of the rider's body parts. A rider who, for this reason, considers that he needs to make use of a distance between 75 and 80 cm must inform the commissaires' panel at the moment that he presents his licence. In such cases the commissaires' panel may carry out the following test: ensuring that the angle between the forearm and upper arm does not exceed 120° when the rider is in a racing position.

(text modified on 7.06.00; 1.01.05).

Structure (1b)

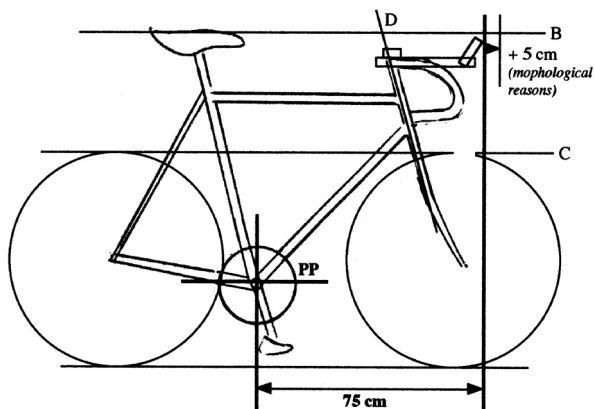

road time trials (individual and team) and track races (individual and team pursuit, kilometre, 500 metres and record attempts).

1.3.024 Any device, added or blended into the structure, that is destined to decrease, or which has the effect of decreasing, resistance to air penetration or artificially to accelerate propulsion, such as a protective screen, fuselage form of fairing or the like, shall be prohibited.

Structure (2)

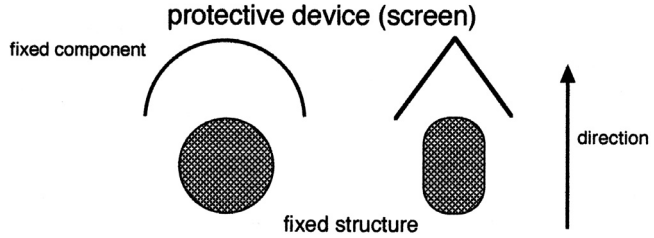

A protective screen shall be defined as a fixed component that serves as a windscreen or windbreak designed to protect another fixed element of the bicycle in order to reduce its wind resistance.

Form

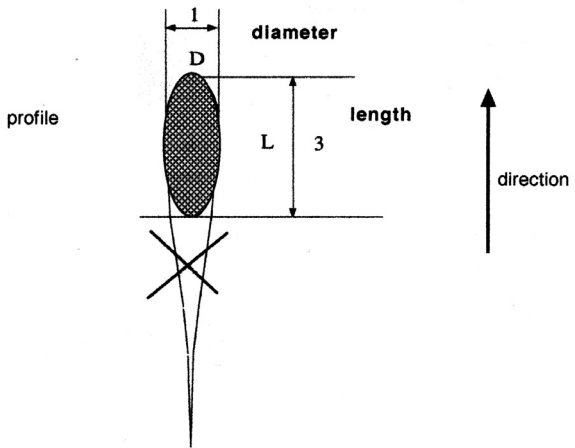

A fuselage form shall be defined as an extension or streamlining of a section. This shall be tolerated as long as the ratio between the length L and the diameter D does not exceed 3.

Structure (3)

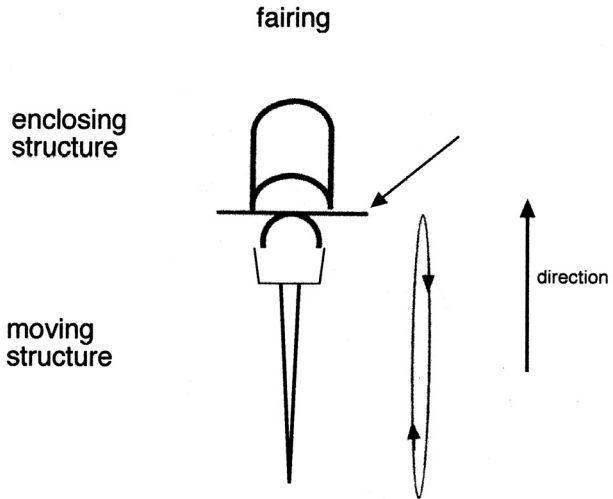

practical way of confirming the existence of fairing on a moving part such as a wheel : it should be possible to pass a rigid card (like a credit card) between the fixed structure and the moving part.

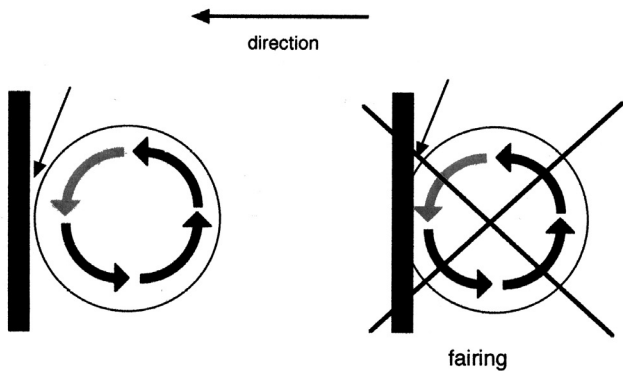

A fairing shall be defined as the use or adaptation of a component of the bicycle in such a fashion that it encloses a moving part of the bicycle such as the wheels or the chainset. Therefore it should be possible to pass a rigid card (like a credit card) between the fixed structure and the moving part.

1.3.025 Freewheels, multiple gears and brakes are not permitted for use on the track during competition or training.

Disc brakes are forbidden in cyclo-cross training and competition.

(text modified on 1.09.04; 1.01.05).

Section 3: riders' clothing

§ 1

General provisions

1.3.026 When competing, all riders shall wear a jersey with sleeves and a pair of shorts, possibly in the form of a one-piece skinsuit. By shorts it is understood that these are shorts that come above the knee. Sleeveless jerseys shall be forbidden.

However, for downhill and 4-cross mountain bike events, BMX, trials and indoor cycling, specific provisions are laid down in the part of the regulations concerning the discipline in question.

(text modified on 1.01.02; 1.01.04; 1.01.05).

1.3.027 Jerseys shall be sufficiently distinct from world champions', UCI cup and classification leaders' and national jerseys to avoid confusion.

1.3.028 Save in cases expressly provided for in the regulations, no distinctive jersey may be awarded or worn.

1.3.029 No item of clothing may hide the lettering on the jersey or the rider's identification number, particularly in competition and at official ceremonies.

(text modified on 1.01.05).

1.3.030 Rain capes must be transparent or made to look like the jersey.

(text modified on 1.01.00).

- 1.3.031**
1. Wearing a rigid safety helmet shall be mandatory during competitions and training sessions in the following disciplines: track, mountain bike, cyclo-cross, trials and BMX.
 2. During competitions on the road, a rigid safety helmet shall be worn.

Except where legal provisions determine otherwise, riders taking part in UCI ProTour events may, at their own risk, refrain from wearing a helmet during individual time trial races taking place entirely on a mountainous course. Every discussion regarding the qualification «entirely on a mountainous course» will be decided by the commissaires' panel.

3. Each rider shall be responsible for:
- ensuring that the helmet is approved in compliance with an official security standard and that the helmet can be identified as approved;
 - wearing the helmet in accordance with the security regulations in order to ensure full protection, including but not limited to a correct adjustment on the head as well as a correct adjustment of the chin strap;
 - avoiding any manipulation which could compromise the protective characteristics of the helmet and not wearing a helmet which has been undergone manipulation or an incident which might have compromised its protective characteristics;
 - using only an approved helmet that has not suffered any accident or shock;
 - using only a helmet that has not been altered or had any element added or removed in terms of design or form.

(text modified on 5.05.03; 1.01.04; 1.08.04; 1.01.05).

1.3.032 [abrogated].

1.3.033 It shall be forbidden to wear non-essential items of clothing or items designed to reduce air resistance.

In road and mountain bike races, items of clothing may be considered essential where weather conditions make them appropriate. In this case, the nature and texture of the clothing must be clearly and solely justified by the need to protect the rider from bad weather conditions. Discretion in this respect is left to the race commissaires.

(text modified on 1.01.02; 1.01.04).

1.3.034 During competitions, riders' attendants may not bear any advertising matter on their clothing other than that authorised for their team's riders for the race in question.

§ 2 Teams registered with the UCI

General observations

1.3.035 Each team may have only a single design for clothing (colours and layout) which may not be altered for the duration of the calendar year.

(text modified on 1.01.00; 1.01.05).

1.3.036 UCI ProTeams and professional continental teams must submit a specimen of their clothing to UCI headquarter no later than December 31st before the year in question. Other entities shall lodge, within the same deadline, a specimen of their clothing at the headquarters of the national federation of the team.

(text modified on 1.01.00; 1.01.04; 1.01.05).

1.3.037 Riders' clothing shall always be identical to the specimen lodged.

(text modified on 1.01.99).

Advertising matter

1.3.038 The name, company logo or trade mark of the principal partner shall be preponderant (thicker characters) and placed in the upper part of the jersey, both on the front and the back.

If there be two principal partners registered with UCI, one of them least shall appear as mentioned above.

1.3.039 The order in which the two principal partners appear on the jersey may be inverted from one race to another during the calendar year.

1.3.040 [abrogated on 1st January 1998].

1.3.041 [abrogated].

1.3.042 Other advertising inscriptions may be freely used and can vary from one race or country to another.

1.3.043 In all cases, the advertising matter and its layout shall be the same for all riders of a given team in the same competition.

(text modified on 1.01.00; 1.01.05).

1.3.044 In track events, by mutual agreement between the race organiser and the team, the team jersey may be replaced by a jersey devoid of advertising matter, not even bearing the name of the team itself.

In six-day races, the organiser may impose jerseys with the advertisement of his choice, while allowing the rider's sponsor to place its name in a rectangle of maximum 6 cm in height.

(text modified on 1.01.00; 1.01.05).

§ 3

Regional and club teams

General observations

1.3.045 For the events on the national calendar, the team may only use a single design of clothing (colours and arrangement) which must remain unaltered throughout the calendar year. In other respects, the matter shall be decided by the national federation of the country where the race is run.

For events on the international calendar, the rules below shall apply to riders belonging to a regional or club team, with the exception of riders who are also members of a team registered with the UCI.

(text modified on 1.01.05).

- 1.3.046** Each regional or club team for whom one or more riders take part in an event on the international calendar must, at the start of the year, notify the details of their clothing to their national federation specifying in detail the colours and their arrangement and the main sponsors.

The name of the region and/or club may appear, in full or in abbreviated form, on the jersey.

(text modified on 1.01.05).

- 1.3.047** Riders for the club shall wear uniform clothing complying exactly with that described in the notification referred to in article 1.3.046. Unless specifically provided for, no rider shall be permitted to ride in the colours of any association or company other than those of the club given on his licence.

Advertising matter

- 1.3.048** Clubs may display the names (logo or trade mark) of their commercial sponsors on their clothing by way of advertising.

A prior written agreement has to be concluded between the club and the sponsor.

- 1.3.049** The name, logo or trade mark of the sponsor(s) may be used freely on the jersey. In addition the jersey may bear other lettering which may even differ from one race or country to another, without any limitation on the number.

(text modified on 1.01.00).

- 1.3.050** [abrogated on 1st January 2005].

§ 4 Leaders' clothing

Stage races

- 1.3.051** A classification leader's jersey in stage races must be sufficiently distinct from those of the teams and clubs, as well as from national jerseys, world champions' jerseys and those of UCI cups, series and classification leaders.

(text modified on 1.01.05).

- 1.3.052** (N) An individual general classification leader's jersey shall be mandatory.

- 1.3.053** (N) Advertising on a leader's jersey shall be reserved for the organiser of the race.

However, on the upper front and back of the jersey, in a rectangle 32 cm high and 30 cm wide, the lower 22 cm shall be reserved for use by the teams on a white background. The principal partner(s) of a team shall stand out there from all other advertisements.

This provision shall also apply to the skinsuit worn by the leader; the lower part (shorts) of the skinsuit shall be reserved for team advertising within a 9 cm wide horizontal band on each leg.

(text modified on 1.01.00; 1.01.05).

- 1.3.054** The wearer of the leader's jersey shall be entitled to match the colour of his shorts to that of the jersey.

(text modified on 1.01.99).

- 1.3.055** In time trial stages, leaders may wear the aerodynamic jersey or skinsuit of their teams if the organiser does not provide an aerodynamic leader's jersey or skinsuit.

(text modified on 1.01.05).

UCI cups, series and classifications

- 1.3.055** 1. The designs of the leader's jerseys for UCI cups, series and classifications are determined by the UCI and are their exclusive property. They may not be reproduced without UCI authorisation. They may not be altered, except as regards the advertising space reserved for the wearer's team.
2. Advertising on the leader's jerseys of UCI cups, series and classifications is reserved for the UCI.

However, on the upper front and back of the jersey, in a rectangle 32 cm high and 30 cm wide, the lower 22 cm shall be reserved for use by the teams on a white background. The principal partner(s) of a team shall stand out there from all other advertisements.

This provision shall also apply to the skinsuit worn by the leader; the lower part (shorts) of the skinsuit shall be reserved for team advertising within a 9 cm wide horizontal band on each leg.

3. On the UCI ProTour leader's clothing, the following spaces are also reserved for the leader's team:
- sides of the jersey: a 9 cm wide lateral strip;
 - sides and rear of the shorts: a 9 cm wide lateral strip;
 - the manufacturer's label (25 cm² maximum) may appear once only on the jersey and once on each leg of the shorts.
4. The wearer of the leader's jersey shall be entitled to match the colour of his shorts to that of the jersey.
5. In time trial stages, leaders may wear the aerodynamic jersey or skinsuit of their teams if the UCI does not provide an aerodynamic leader's jersey or skinsuit.

6. Wearing the leader's jersey or **corresponding piping** is prohibited as soon as the anti-doping commission, after the review described in article 186 of the anti-doping rules, asserts that the rider committed an anti-doping violation and until his definitive acquittal.

(text introduced on 1.01.05; modified on 1.09.05; 1.01.06).

§ 5 National team clothing

- 1.3.056** National federations shall, 6 weeks before an event as specified in art. 1.3.059, submit to the UCI a sample of their national team clothing after a change (colour, design, advertising, size of the advertisement, layout, etc.) has been made.

The team clothing of the riders of a national team shall in all cases be identical to the last design submitted.

(text modified on 17.07.98; 1.01.04).

- 1.3.057** The following advertising shall be authorised:
- front of the jersey: 2 logos of 64 cm² maximum;
 - area comprising shoulders and sleeves: strip of maximum 5 cm high;
 - on the sides of the jersey: a 9 cm wide strip;
 - sides of the shorts: a 9 cm wide strip;
 - the manufacturer's label (25 cm²) may appear once only on the jersey and once on each leg of the shorts.

Advertising matter on jersey and shorts may vary from one rider to another.

The design of the jersey and shorts may vary from one category of rider to another.

Advertising on protective leggings worn for downhill mountain bike, trials and BMX events is not subject to the advertising restrictions on shorts.

Additionally, the rider's name may appear on the back of the jersey.

The above measures also apply to other items of clothing worn during competition (rain jackets, etc.).

(text modified on 1.01.00; 1.01.03; 1.01.04; 1.01.05).

- 1.3.058** The advertising spaces shall be reserved for the use of the national federation except in the following cases:

- a) track world cup
for riders belonging to a team registered with the UCI, the advertising spaces are reserved for the team, except for a logo of 64 cm² on the front of the jersey which is reserved for the national federation.
- b) cyclo-cross world cup
If the rider has one or more sponsors, a rectangle of height 10 cm and width 30 cm on the front and rear of the jersey shall in the first instance be reserved for their use. In this case these rectangles comprise the only advertising spaces available on these parts of the jersey. If and only if there is no advertising for a rider's sponsors, the national federation may make use of two 64 cm² logos on the front of the jersey.

Riders who belong to a trade team or club can wear the jersey of their trade team or club, as long as they notify the National Federation of this when they apply for selection. Otherwise the National Federation may require the wearing of the national jersey. The national jersey is compulsory for the U23 and Junior National teams.

- c) BMX world and continental championships and challenges
If the rider has one or more sponsors, a rectangle of height 10 cm and width 30 cm on the front and rear of the jersey shall be reserved for their use. In this case these rectangles comprise the only advertising spaces available on these parts of the jersey. If and only if there is no advertising for a rider's sponsors, the national federation may make use of two 64 cm² logos on the front of the jersey. The other advertising spaces on the jersey (shoulder and sleeve strip, sides) are reserved in the first instance for the rider's sponsor(s).

(text modified on 17.07.98; 1.01.05).

- 1.3.059** The wearing of national team clothing shall be mandatory:
- at world championships
 - at continental championships
 - **for the riders of a national team**
 - during Olympic Games, in accordance with the IOC and NOC Regulations.

(text modified on 1.01.98; 1.01.04; 1.01.05; 1.01.06).

§ 6 World champion's jersey

- 1.3.060** There are different world champion's jerseys according to category and/or discipline.
- 1.3.061** The design, including colours and layout, of each world champion's jersey is the exclusive property of the UCI. The jersey may not be reproduced without UCI authorisation. The design may in no way be modified.
- 1.3.062** [abrogated on 1st January 2005].

1.3.063 Until the day before the world championship of the following year, the world champions must wear their jersey in all events in the discipline, speciality and category in which they won their title, and in no other event.

For the purpose of this rule, the team time trial is put on a par with the individual time trial.

In six-day races, only madison world champions may wear the jersey, even if they are not paired together.

(text modified on 1.01.05; 1.01.06).

1.3.064 When he no longer holds the title of world champion, a rider may wear rainbow piping on the collar and cuffs of his jersey as per the technical specifications in the brochure which will be sent to him by the UCI. However, he may wear such a jersey only in events of the discipline and speciality in which he won the title and in no other event.

(text modified on 1.01.05; 1.09.05).

1.3.065 Wearing the world champion's jersey or the rainbow piping is prohibited as soon as the anti-doping commission, after the review described in article 186 of the anti-doping rules, asserts that the rider committed an anti-doping violation and until his definitive acquittal.

(text modified on 1.01.05; 1.09.05).

1.3.066 The world champion's jersey awarded at the official ceremony may carry no advertising matter other than that determined by the UCI.

1.3.067 The world champion shall be entitled to have advertising matter placed on his jersey from the day following the official ceremony until the day before the next world championships.

That advertising shall be strictly limited to the following spaces:

- on the front and back of the jersey, in a rectangle 10 cm high above the rainbow colours;
- area comprising shoulders and sleeves: maximum 5 cm high in a single line;
- the manufacturer's label (25 cm²).

The exact location of advertising space is defined in a document provided by the UCI to each national federation of which a rider becomes world champion.

The wearer of the world champion's jersey shall be entitled to match the colour of his shorts to that of the jersey.

(text modified on 1.01.01).

§ 7 National champion's jersey

1.3.068 National road, track, cyclo-cross, mountain bike, BMX, trials and indoor cycling champions must wear their jersey in all events in the discipline, speciality and category in which they won their title and no other event.

For the purpose of this rule, the team time trial is put on a par with the individual time trial.

In a six-day event, only madison national champions must wear the jersey even if they are not paired together.

(N) When he no longer holds the title of national champion, a rider must wear piping in national colours on the collar and cuffs of his jersey as per the technical specifications determined by the national federation. However, he must wear such a jersey only in events of the discipline and speciality in which he won the title and in no other event.

Wearing the national champion's jersey or piping in national colours is prohibited as soon as the anti-doping commission, after the review described in article 186 of the anti-doping rules, asserts that the rider committed an anti-doping violation and until his definitive acquittal.

(text modified on 1.01.99; 1.01.04; 1.01.05; 1.01.06).

1.3.069 On the national champion's jersey, the following advertising spaces shall be authorised:

- on the front and back of the jersey, in a rectangle 10 cm high;
- area comprising shoulders and sleeves: maximum 5 cm high in a single line;
- on the sides of the jersey: a 9 cm wide strip;
- the manufacturer's label (25 cm²) may appear once only on the jersey and once on each leg of the shorts.

these advertising spaces shall be reserved for the rider's usual sponsors.

The wearer of a national champion's jersey shall be entitled to match the colour of his shorts to that of the jersey.

(text modified on 1.01.01; 1.01.04).

§ 8 Continental champion's jersey

1.3.070 If a jersey is awarded at a continental championship, the rider may wear it in all races in the discipline, speciality and category in which he won the title and for as long as he continues to hold the title.

The authorised advertising spaces shall be identical to those on the world champion's jersey.

Wearing the continental champion's jersey is prohibited as soon as the anti-doping commission, after the review described in article 186 of the anti-doping rules, asserts that the rider committed an anti-doping violation and until his definitive acquittal.

(text modified on 1.01.04; 1.01.05; 1.09.05).

§ 9**Order of priority**

1.3.071 Should various provisions requiring the wearing of different jerseys apply to the same rider, the order of priority shall be as follows:

1. the leader's jersey of the stage race
2. the leader's jersey of the cup, series or UCI classification
3. the world champion's jersey
4. the national champion's jersey
5. the continental champion's jersey
6. the national jersey

Where the leader of the UCI ProTour is also road world champion, he must wear a UCI ProTour leader's clothing showing the rainbow colours. The advertising shall comply with the terms of article 1.3.067.

(text modified on 26.08.04; 1.01.05; 1.01.06).

1.3.072 The following infringements shall be penalised as indicated below:
(the sums are the fine in Swiss francs)

1. Non-regulation clothing (colour and layout)
 - rider: 50 to 200 and start not permitted
 - team: 250 to 500 per rider
2. Non-regulation advertising
 - 2.1 Team, per rider bearing non-regulation advertising:
 - jersey: 500 to 2100 and start of the rider concerned not permitted
 - shorts: 300 to 1050 and start of the rider concerned not permitted
 - skinsuit: 700 to 3000 and start of the rider concerned not permitted
3. Leader's jersey
 - 3.1 Unavailability of jerseys or skinsuits as required by the race regulations
 - organiser: 1000 to 2100 per rider concerned
 - 3.2 Leader's jersey or skinsuit not fit to wear
 - organiser: 1000 to 2100 per rider concerned
 - 3.3 Allocation of unauthorised jerseys
 - organiser: 1000 to 2100 per jersey concerned

4. Rider not wearing:
 - world champion's jersey: team: 2500 to 5000 and start of the rider concerned not permitted
 - leader's jersey of a UCI cup, circuit, series or classification:
 - team: 2500 to 5000 and start of the rider concerned not permitted
 - rider: start not permitted and loss of 50 points in the UCI classification concerned
 - national champion's jersey: team: 2500 to 5000
 - continental champion's jersey: team: 1250 to 2500 and start of the rider concerned not permitted
 - national clothing: team: 500 to 1000 per rider and start of the riders concerned not permitted

(text modified on 1.01.06).

5. National team clothing:
 - failure to submit to the UCI (article 1.3.056): national federation: 500 to 10000.
6. World champion's jersey:
 - in breach of article 1.3.066 or 1.3.067: rider: 2000 to 100000
 - wearing of the jersey in a discipline, speciality or category other than that in which it was won:
 - rider:
 - up to 31 December 2005:
 - first offence: warning
 - subsequent offence: 2000 to 10000
 - as from January 1st 2006:
 - 2000 to 10000
 - in breach of article 1.3.065: rider: 200 to 10000
7. National champion's jersey: in breach of article 1.3.068, second paragraph: rider: 200 to 10000

The amounts of the fines set above are doubled in the event of an offence during a world championship.

(text modified on 1.03.01; 1.01.04; 1.01.05).

Section 4: identification of riders

1.3.073 Identification number*

During competitions, the following provisions shall be made for the identification of riders.

Discipline/speciality	Body number	Frame number	Shoulder number	Handlebar number
Road				
One-day races	2	1		
Stage races	2	1		
Time trials	1			
Cyclo-cross	1		2	
Track				
Sprint	2			
Ind. pursuit.	1			
Team pursuit	1			
1 km TT	1			
500 m TT	1			
Points race	2			
Keirin	2			
Team sprint	1			
Madison	2			
BMX	1	1		
Mountain bike (all events)	1			1

* The shoulder numbers shall be worn on the upper forearm so it's visible frontally.

(text modified on 1.01.01; 1.01.04; 1.01.05; 1.09.05; 1.01.06).

1.3.074 Unless otherwise stipulated the number panels and plates shall bear black characters on a white background.

1.3.075 The characters, panels and plates shall be of the following dimensions:

	Body number	Frame number	Shoulder number	Handlebar number
Height	18 cm	9 cm	11 cm	18 cm MTB 20 cm BMX
Width	16 cm	13 cm	12 cm	18 cm MTB 25 cm BMX
Digits	10 cm	6 cm	7 cm	8 cm MTB 10 cm BMX
Line width	1.5 cm	0.8 cm	0.8 cm	1.5 cm MTB and BMX
Advertising	height 6 cm on the lower part	rectangle of 11x2 cm on the lower part	height 2 cm on the lower part	the upper and lower part - BMX upper height 6 cm on the lower part

(text modified on 1.01.01; 1.01.04).

1.3.076 Riders shall ensure that their identification number is visible and legible at all times. The identification number shall be well fixed and may not be folded or altered.

(text modified on 1.01.05).

1.3.077 Identification numbers shall be provided free of charge by the organiser. They shall be issued after the rider's licence has been checked by the commissaires' panel.

(text modified on 1.01.05).

1.3.078 *At world championships, the identification numbers shall be provided by the UCI. The advertising space shall be reserved for the UCI.*

(text modified on 1.01.05).

1.3.079 [abrogated 1st January 2005].

1.3.080 Any rider dropping out of the race shall immediately remove his identification number.

(text modified on 01.01.05).