



JAMAICA

EDUCATION

STATISTICS

2008-2009

ANNUAL STATISTICAL REVIEW OF THE EDUCATION SECTOR
MINISTRY OF EDUCATION, KINGSTON, JAMAICA

**MINISTRY OF EDUCATION
EDUCATION STATISTICS
2008 - 2009**

**STATISTICS SECTION
PLANNING & DEVELOPMENT DIVISION
MINISTRY OF EDUCATION
KINGSTON, JAMAICA**

EDUCATION STATISTICS 2008/2009

TABLE OF CONTENTS

	PAGE
INTRODUCTION	1
SECTOR OVERVIEW	
THE FORMAL EDUCATION SYSTEM	3
FLOW CHART: PRE-PRIMARY, PRIMARY, SECONDARY AND TERTIARY LEVELS	5
THE FORMAL PUBLIC EDUCATION SYSTEM IN JAMAICA: ORGANIZATION CHART	6
1 – 1 SUMMARY OF TEACHING STAFF BY LEVEL AND TYPE OF EDUCATIONAL INSTITUTION	7
1 – 3a SUMMARY OF STUDENT ENROLMENT BY LEVEL AND TYPE OF EDUCATIONAL INSTITUTION	10
1 – 4 DISTRIBUTION OF PUBLIC EDUCATIONAL INSTITUTIONS (EARLY CHILDHOOD, PRIMARY, SPECIAL) BY TYPE AND PARISH	12
1 – 5 DISTRIBUTION OF PUBLIC EDUCATIONAL INSTITUTIONS (SECONDARY, TERTIARY) BY TYPE AND PARISH	13

SECTOR OVERVIEW

PAGE

1 – 6a	DISTRIBUTION OF PUBLIC EDUCATIONAL INSTITUTIONS (INFANT, PRIMARY, ALL AGE PRIMARY & JUNIOR HIGH AND SPECIAL) BY REGION AND PARISH.	14
1 – 6b	DISTRIBUTION OF PUBLIC EDUCATIONAL INSTITUTIONS (SECONDARY AND TERTIARY) BY REGION AND PARISH	15
1 – 7	DISTRIBUTION OF INDEPENDENT INSITUTIONS BY PARISH	16
1 – 8	NUMBER OF PUBLIC EDUCATIONAL INSTITUTIONS WITH SHIFT BY SCHOOL TYPE AND PARISH	17

TEACHER STATISTICS

	OVERVIEW	19
2 – 1	TEACHERS IN INFANT, PRIMARY AND SECONDARY LEVEL SCHOOLS BY TYPE OF INSTITUTION, SEX AND PARISH	23
2 – 2	TEACHERS IN INFANT, PRIMARY AND SECONDARY SCHOOLS BY POST, SEX AND PARISH	24

TEACHER STATISTICS

	PAGE
2 – 3	TEACHERS IN INFANT, PRIMARY AND SECONDARY SCHOOLS BY QUALIFICATION, SEX AND PARISH 25
2 – 4	TEACHERS IN INFANT, PRIMARY AND SECONDARY SCHOOLS BY QUALIFICATION, SEX AND REGION 26
2 – 5	TEACHERS IN INFANT SCHOOLS BY POST, SEX AND PARISH 27
2 – 6	TEACHERS IN INFANT SCHOOLS BY QUALIFICATION, SEX AND PARISH 28
2 – 7	TEACHERS IN INFANT DEPARTMENTS OF PRIMARY SCHOOLS BY POST, SEX AND PARISH 29
2 – 8	TEACHERS IN INFANT DEPARTMENTS OF PRIMARY SCHOOLS BY QUALIFICATION, SEX AND PARISH 30
2 – 9	TEACHERS IN INFANT DEPARTMENTS OF ALL AGE SCHOOLS BY POST, SEX AND PARISH 31
2 – 10	TEACHERS IN INFANT DEPARTMENTS OF ALL AGE SCHOOLS BY QUALIFICATION, SEX AND PARISH 32

TEACHER STATISTICS

PAGE

2 – 11	TEACHERS IN INFANT DEPARTMENTS OF PRIMARY AND JUNIOR HIGH BY POST, SEX AND PARISH	33
2 – 12	TEACHERS IN INFANT DEPARTMENTS OF PRIMARY AND JUNIOR HIGH BY QUALIFICATION, SEX AND PARISH	34
2 – 13	TEACHERS IN PRIMARY SCHOOLS BY POST, SEX AND PARISH	35
2 – 14	TEACHERS IN PRIMARY SCHOOLS BY QUALIFICATION, SEX AND PARISH	36
2 – 15	TEACHERS IN ALL AGE SCHOOLS GRADES 1 - 6 BY POST, SEX AND PARISH	37
2 – 16	TEACHERS IN ALL AGE SCHOOLS GRADES 1 - 6 BY QUALIFICATION, SEX AND PARISH	38
2 – 17	TEACHERS IN ALL AGE SCHOOLS GRADES 7 - 9 BY POST, SEX AND PARISH	39
2 – 18	TEACHERS IN ALL AGE SCHOOLS GRADES 7 - 9 BY QUALIFICATION, SEX AND PARISH	40
2 – 19	TEACHERS IN PRIMARY AND JUNIOR HIGH SCHOOLS GRADES 1 - 6 BY POST, SEX AND PARISH	41
2 – 20	TEACHERS IN PRIMARY AND JUNIOR HIGH SCHOOLS GRADES 1 - 6 BY QUALIFICATION, SEX AND PARISH	42
2 – 21	TEACHERS IN PRIMARY AND JUNIOR HIGH SCHOOLS GRADES 7 - 11 BY POST, SEX AND PARISH	43

TEACHER STATISTICS

PAGE

2 – 22	TEACHERS IN PRIMARY AND JUNIOR HIGH SCHOOLS GRADES 7 - 11 BY QUALIFICATION, SEX AND PARISH	44
2 – 23	TEACHERS IN SECONDARY HIGH SCHOOLS BY POST, SEX AND PARISH	45
2 – 24	TEACHERS IN SECONDARY HIGH SCHOOLS BY QUALIFICATION, SEX AND PARISH	46
2 – 25	TEACHERS IN TECHNICAL HIGH SCHOOLS BY POST, SEX AND PARISH	47
2 – 26	TEACHERS IN TECHNICAL HIGH SCHOOLS BY QUALIFICATION, SEX AND PARISH	48
2 – 27	TEACHERS IN AGRICULTURAL HIGH SCHOOLS BY POST, SEX AND PARISH	49
2 – 28	TEACHERS IN AGRICULTURAL HIGH SCHOOLS BY QUALIFICATION, SEX AND PARISH	50
2 – 29	PERCENTAGE DISTRIBUTION OF TEACHERS IN INFANT, PRIMARY AND SECONDARY SCHOOLS BY QUALIFICATION 2003 to 2007	51
2 – 30	PERCENTAGE DISTRIBUTION OF TRAINED TEACHERS AT THE EARLY CHILDHOOD, PRIMARY AND SECONDARY LEVELS 2003 to 2007	52
2 – 31	TEACHER - PUPIL RATIO IN INFANT, PRIMARY AND SECONDARY LEVEL SCHOOLS	53
2 – 32	ACADEMIC STAFF IN TERTIARY INSTITUTIONS BY QUALIFICATION, SEX AND INSTITUTION	54
2 – 33	ACADEMIC STAFF IN COMMUNITY COLLEGES BY POST, SEX AND INSTITUTION	55

TEACHER STATISTICS

PAGE

2 – 34	ACADEMIC STAFF IN COMMUNITY COLLEGES BY QUALIFICATION, SEX AND INSTITUTION	56
2 – 35	ACADEMIC STAFF AT MONEAGUE COLLEGE BY POST AND SEX	57
2 – 36	ACADEMIC STAFF AT MONEAGUE COLLEGE BY QUALIFICATION AND SEX	57
2 – 37	ACADEMIC STAFF IN TEACHERS' COLLEGES BY POST, SEX AND INSTITUTION	58
2 – 38	ACADEMIC STAFF IN TEACHERS' COLLEGE BY QUALIFICATION, SEX AND INSTITUTION	59
2 – 39	ACADEMIC STAFF AT G.C. FOSTER COLLEGE OF PHYSICAL EDUCATION AND SPORTS BY POST AND SEX	60
2 – 40	ACADEMIC STAFF AT G.C. FOSTER COLLEGE OF PHYSICAL EDUCATION AND SPORTS BY QUALIFICATION AND SEX	60
2 – 41	ACADEMIC STAFF AT THE COLLEGE OF AGRICULTURE, SCIENCE AND EDUCATION BY POST AND SEX	61
2 – 42	ACADEMIC STAFF AT THE COLLEGE OF AGRICULTURE, SCIENCE AND EDUCATION BY QUALIFICATION AND SEX	61
2 – 43	FULL TIME ACADEMIC STAFF AT EDNA MANLEY COLLEGE OF THE VISUAL AND PERFORMING ARTS BY POST AND SEX	62

2 – 44	FULL TIME ACADEMIC STAFF AT EDNA MANLEY COLLEGE OF THE VISUAL AND PERFORMING ARTS BY QUALIFICATION AND SEX	62
2 – 45	FULL TIME ACADEMIC STAFF AT THE UNIVERSITY OF TECHNOLOGY BY POST, DEPARTMENT/SCHOOL AND SEX	63
2 – 46	FULL TIME ACADEMIC STAFF AT THE UNIVERSITY OF TECHNOLOGY BY DEPARTMENT/SCHOOL, QUALIFICATION AND SEX	64
2 – 47	TEACHERS IN SPECIAL EDUCATION INSTITUTIONS BY QUALIFICATIONS, SEX AND PARISH	65

STUDENT STATISTICS

		PAGE
	OVERVIEW	67
3 – 1(a)	PERCENTAGE DAILY ATTENDANCE BY REGION AND LEVEL.....	69
3 – 1(b)	PERCENTAGE DAILY ATTENDANCE BY REGION AND LEVEL.....	69
3 – 2	ENROLMENT IN PRIMARY, ALL AGE AND SECONDARY SCHOOLS BY AGE, SEX AND GRADE.	71
3 – 3	ENROLMENT IN PRIMARY AND SECONDARY LEVEL SCHOOLS BY REGION, GRADE AND SEX	72
3 – 4	ENROLMENT IN PRIMARY, ALL AGE AND SECONDARY SCHOOLS BY PARISH, GRADE AND SEX...	73
3 – 5	ENROLMENT IN INFANT SCHOOLS AND INFANT DEPARTMENTS BY AGE AND SEX	74
3 – 6	ENROLMENT IN INFANT SCHOOLS AND INFANT DEPARTMENTS BY PARISH AND SEX	75
3 – 7	ENROLMENT IN PRIMARY SCHOOLS BY AGE, SEX AND GRADE	76
3 – 8	ENROLMENT IN PRIMARY SCHOOLS BY PARISH, GRADE AND SEX	77

STUDENT STATISTICS

		PAGE
3 – 9	ENROLMENT IN ALL AGE SCHOOLS GRADES 1 - 6 BY AGE, SEX AND GRADE	78
3 – 10	ENROLMENT IN ALL AGE SCHOOLS GRADES 1 - 6 BY PARISH, GRADE AND SEX	79
3 – 11	ENROLMENT IN ALL AGE SCHOOLS GRADES 7 – 9 BY AGE, SEX AND GRADE	80
3 – 12	ENROLMENT IN ALL AGE SCHOOLS GRADES 7 – 9 BY PARISH, GRADE AND SEX	81
3 – 13	ENROLMENT IN PRIMARY AND JUNIOR HIGH SCHOOLS GRADE 1 - 6 BY AGE, SEX AND GRADE.....	82
3 – 14	ENROLMENT IN PRIMARY AND JUNIOR HIGH SCHOOLS GRADE 1- 6 BY PARISH, GRADE AND SEX.....	83
3 – 15	ENROLMENT IN PRIMARY AND JUNIOR HIGH SCHOOLS GRADE 7- 11 BY AGE, SEX AND GRADE	84
3 – 16	ENROLMENT IN PRIMARY AND JUNIOR HIGH SCHOOLS GRADE 7- 11 BY PARISH, GRADE AND SEX	85
3 – 17	ENROLMENT IN SECONDARY HIGH SCHOOLS BY AGE, SEX AND GRADE	86
3 – 18	ENROLMENT IN SECONDARY HIGH SCHOOLS BY PARISH, GRADE AND SEX	87
3 – 19	ENROLMENT IN TECHNICAL HIGH SCHOOLS BY AGE, SEX AND GRADE	88
3 – 20	ENROLMENT IN TECHNICAL HIGH SCHOOLS BY PARISH, GRADE AND SEX	89
3 – 21	ENROLMENT IN AGRICULTURAL HIGH SCHOOLS BY AGE, SEX AND GRADE	90
3 – 22	ENROLMENT IN AGRICULTURAL HIGH SCHOOLS BY PARISH, GRADE AND SEX	91
3 – 23	NUMBER OF REPEATERS BY GRADE, SEX AND SCHOOL TYPE: GRADE 1- 6	92
3 – 24	NUMBER OF REPEATERS BY GRADE, SEX AND SCHOOL TYPE : GRADE 7- 12	93

STUDENT STATISTICS

	PAGE
3 – 25	PROMOTION, REPETITION AND DROP - OUT RATES IN PUBLIC PRIMARY LEVEL EDUCATION. 94
3 – 26	PROMOTION, REPETITION AND DROP - OUT RATES IN PUBLIC SECONDARY LEVEL EDUCATION 94
3 – 27	ENROLMENT IN COMMUNITY COLLEGES BY SEX 95
3 – 28	ENROLMENT AT EDNA MANLEY COLLEGE OF THE VISUAL AND PERFORMING ARTS BY SCHOOL, PROGRAMME AND SEX 96
3 – 29	ENROLMENT IN TEACHER TRAINING PROGRAMMES BY YEAR, INSTITUTION AND SEX 97
3 – 30	ENROLMENT AT THE COLLEGE OF AGRICULTURE, SCIENCE AND EDUCATION BY SCHOOL, PROGRAMME AND SEX 98
3 – 31	REGISTRATION AT THE UNIVERSITY OF TECHNOLOGY BY SCHOOL/DEPARTMENT AND SEX 99
3 – 32	REGISTRATION OF JAMAICAN UNDERGRADUATE STUDENTS IN DEGREE COURSES AT THE UNIVERSITY OF THE WEST INDIES BY CAMPUS, FACULTY/SCHOOL AND SEX 100
3 – 33	REGISTRATION OF JAMAICAN GRADUATE STUDENTS FOR HIGHER DEGREE COURSES AT THE UNIVERSITY OF THE WEST INDIES BY CAMPUS, FACULTY/SCHOOL AND SEX. 101
3 – 34	REGISTRATION OF JAMAICAN STUDENTS FOR CERTIFICATE AND DIPLOMA COURSES AT THE UNIVERSITY OF THE WEST INDIES, MONA CAMPUS BY FACULTY AND SEX 102
3 – 35	ENROLMENT IN SELECTED INDEPENDENT TERTIARY INSTITUTIONS BY GENDER. 103
3 – 36 a	ENROLMENT IN SPECIAL EDUCATION INSTITUTIONS BY PARISH, SEX AND AREA OF DISABILITY 104

3 – 36 b	ENROLMENT IN SPECIAL EDUCATION INSTITUTIONS BY PARISH, SEX AND AREA OF DISABILITY cont'd	105
3 – 37	DISTRIBUTION OF ENROLMENT BY LEVEL AND SCHOOL TYPE	106

EXAMINATION STATISTICS

		PAGE
	OVERVIEW	108
4 – 1	GRADE ONE READINESS INVENTORY	112
4 – 2(a)	GRADE FOUR LITERACY TEST BY REGION AND SEX (FIRST SITTING)	113
4 – 2(b)	GRADE FOUR LITERACY TEST BY REGION AND SUBJECT.	114
4 – 3	GRADE SIX ACHIEVEMENT TEST (GSAT): MEAN SCORES BY SUBJECT AND REGION	115
4 – 4	GRADE NINE ACHIEVEMENT EXAMINATIONS AVERAGE SCORES BY SUBJECT AND REGION	116
4 – 5	CARIBBEAN SECONDARY EDUCATION CERTIFICATE: TOTAL NUMBER OF CANDIDATES SITTING & PERCENTAGE ATTAINING GRADES 1, 2, 3 & 4 AT THE GENERAL PROFICIENCY LEVEL BY SEX	117
4 – 5 (i)	CARIBBEAN SECONDARY EDUCATION CERTIFICATE: TOTAL NUMBER OF CANDIDATES SITTING & PERCENTAGE ATTAINING GRADES 1, 2, 3 & 4 AT THE GENERAL PROFICIENCY LEVEL BY SEX	118
4 – 6	CARIBBEAN SECONDARY EDUCATION CERTIFICATE: TOTAL NUMBER OF CANDIDATES SITTING & PERCENTAGE ATTAINING GRADES 1, 2 & 3 AT THE BASIC PROFICIENCY LEVEL BY SEX	119

4 –7	G.C.E. ADVANCED LEVEL AND ADVANCED SUBSIDIARY LEVEL: NUMBER OF PUBLIC SCHOOL CANDIDATES SITTING PERCENTAGE ATTAINING GRADES A-E AND GRADES a-e	120
4 –8	G.C.E. ADVANCED LEVEL AND ADVANCED SUBSIDIARY LEVEL: NUMBER OF PRIVATE CANDIDATES SITTING PERCENTAGE ATTAINING GRADES A-E AND GRADES a-e	121
4 – 9	G.C.E. ADVANCED LEVEL AND ADVANCED SUBSIDIARY LEVEL: TOTAL NUMBER OF CANDIDATES SITTING PERCENTAGE ATTAINING GRADES A-E AND GRADES a-e	122
4 – 10 (i)	CARIBBEAN ADVANCED PROFICIENCY EXAMINATIONS: TOTAL NUMBER OF CANDIDATES SITTING AND PERCENTAGE ATTAINING GRADES 1-5 UNIT 1.	123
4 – 10 (ii)	CARIBBEAN ADVANCED PROFICIENCY EXAMINATIONS: TOTAL NUMBER OF CANDIDATES SITTING AND PERCENTAGE ATTAINING GRADES 1-5 UNIT 2.	124
4 – 11	UNIVERSITY OF TECHNOLOGY GRADUATES BY DEPARTMENT & SEX	125
4 – 12	JAMAICAN STUDENTS AWARDED FIRST AND HIGHER DEGREES AT THE UNIVERSITY OF THE WEST INDIES BY CAMPUS, FACULTY AND SEX	126
4 – 13	JAMAICAN STUDENTS AWARDED CERTIFICATES AND DIPLOMAS AT THE UNIVERSITY OF THE WEST INDIES MONA BY FACULTY & SEX	127

FINANCIAL STATISTICS

		PAGE
	OVERVIEW	129
5 – 1	MINISTRY OF EDUCATION IN THE NATIONAL BUDGET	
	- (CURRENT COST) REVISED ESTIMATES	132
5 – 2(a)	MINISTRY OF EDUCATION: RECURRENT BUDGET 2005/2006 - 2007/2008	
	- CURRENT PRICES J \$'000	134
5 – 2(b)	MINISTRY OF EDUCATION: CAPITAL BUDGET 2005/2006 - 2007/2008	
	- (CURRENT COSTS J \$'000)	139
5 – 3	MINISTRY OF EDUCATION: PER CAPITA EXPENDITURE BY LEVEL 2005/2006 - 2007/2008	
	- (CURRENT PRICES J \$'000)	143

EDUCATION STATISTICS 2008/2009

LIST OF FIGURES

		PAGE
1.1	FLOW CHART OF FORMAL PUBLIC EDUCATION SYSTEM.....	5
1.2	THE FORMAL PUBLIC EDUCATION SYSTEM IN JAMAICA: ORGANIZATION CHART	6
2.1	DISTRIBUTION OF TEACHERS BY SCHOOL TYPE.....	21
2.2	DISTRIBUTION OF TEACHERS BY QUALIFICATION	22
3.1	DISTRIBUTION OF ENROLMENT BY LEVEL	68
3.2	DISTRIBUTION OF ENROLMENT BY PARISH	70

INTRODUCTION

This year marks the 33rd publication of the **Jamaica Education Statistics**. This publication gives a statistical overview of the Jamaican public institutions with regards to their plant, teachers, students, examinations and financial status for the academic year 2008-2009. The report also gives a summary of student enrolment and the distribution of schools by type for private institutions.

The Education Statistics is based on data collected during our annual census. For the year under review Census Day was October 13, 2008. Data presented on enrolment and teachers relate to the status of the education system as on that day. For the academic year 2008-2009, there were no new schools; however Gordon Town All Age was renamed to Louise Bennett Coverley All Age. The total number of schools decreased from 1015 to 1013, as a result of the closure of two schools. The number of Primary schools increased from 543 to 546, as 3 schools were reclassified from All Age schools to Primary schools. This, in addition to the closure of Bluefields All Age contributed to the number of All Age schools declining from 163 to 159. The number of secondary schools declined to 147 from 148, with the closure of Priory High School. All other school types remained the same.

The distribution of educational institutions by type and parish and a flow diagram of pupil/student movement from one level to the next are illustrated in Table 1-4, Table 1-5 and Figure 1.1 respectively. An organizational chart showing the official age range of students, by school type and level (Figure 1.2), and summaries of student enrolment and teaching staff by type of educational institution are included on pages 7 to 11.

This publication provides timely data as supplied by public and private institutions and is a reflection of what can be achieved through a collaborative and integrated effort. The MOE anticipates that the publication will assist policymakers, students, researchers and other stakeholders to get a better perspective of the education sector. It is our hope that information presented will be useful to you. Thanks to the Director - Planning and Development Division; A.C.E.O - Policy Analysis, Research and Statistics, Regional Directors, MIS Officers in the regions, Principals, Education Officers, the Statistician, the Data Control Officer, the Data Preparation Officers and the Management Information Systems Unit for their co-operation and assistance in making this publication possible.

Phillipa Livingston (Mrs.)
Senior Statistician (Acting)
MINISTRY OF EDUCATION

SECTOR

OVERVIEW

THE FORMAL EDUCATION SYSTEM

Jamaica's formal education system has four levels established by the Education Act of 1965: early childhood, primary, secondary and tertiary. The government is the main provider of education with a relatively small degree of private sector participation.

Early Childhood education is provided for children in the age group 4 to 5 years in Infant schools, Infant Departments of Primary, All Age and Primary & Junior High schools, as well as, children in the age group 3 to 5 years in **Nursery**, Kindergarten and Basic schools. Although Basic schools are community operated, those recognised by government receive subsidies to supplement teachers' salaries, and support the provision of instructional materials and lunch.

Primary education is offered to pupils 6 to 11 years old, in grades 1 to 6 of Primary, All Age, Primary & Junior High and Preparatory schools. It is at this level that the foundation is set for the acquisition of knowledge, skills and values for total development and continuation of the child's education.

Secondary level education is offered in two cycles. The first cycle is three years and is provided in grades 7 to 9 for students 12 to 14 years old. This is followed by a second cycle of two years in grades 10 and 11 for students 15 to 16 years old. Some institutions offer a further two years at grades 12 and 13. Five years of secondary education is offered in Secondary High and some Technical High schools. All Age, Primary & Junior High and Agricultural High schools offer three years of secondary education.

Special education spans the first three levels of the education system. It caters to children who find it difficult to learn in the regular school setting without specialised support services. Special education provides for the blind, deaf and hearing impaired, mentally challenged, students with multiple disabilities, the physically challenged, the learning disabled and the gifted and talented.

Tertiary level education is offered to persons who have successfully completed secondary education and are desirous of pursuing further studies. At the tertiary level the main institutions are:

- The University of the West Indies (UWI), which offers education at the under-graduate and post-graduate levels in various faculties and schools, including Humanities and Education, Law, Medical Sciences, Pure and Applied Sciences and the Social Sciences.

THE FORMAL EDUCATION SYSTEM

- The University of Technology (UTECH) offers a wide variety of technical programmes in the various disciplines: Building, Architecture, Commerce, Computer Studies, Engineering, Hospitality & Food Science, Science & Health Science and Technical Education (a training programme in teacher education). In addition to granting degrees, UTECH offers certificates, diplomas, and professional awards.
- Five Teachers' Colleges, including the newly upgraded Mico University College, which provide professional training in teacher education for early childhood, primary, secondary and special education.
- College of Agriculture, Science and Education (CASE), which is the main institution responsible for training in agricultural programmes leading to a Bachelor of Technology and an Associate degree. It also offers training in teacher education.
- G.C. Foster College of Physical Education and Sports which provides professional training in sports administration, coaching and the teaching of sports and physical education.
- Edna Manley College of the Visual and Performing Arts (EMCV&PA) comprises four schools. The schools of Art, Dance, Drama and Music which offer certificate and diploma courses, professional training, training in teacher education and undergraduate degrees.
- Moneague College (M.C.) and Bethlehem Moravian College are multi-disciplinary institutions that offer training in teacher education, professional programmes and community related courses.
- Five Community Colleges, which offer pre-university programmes, professional, commercial and vocational training as well as community oriented courses.

Private Institutions:

The University Council of Jamaica (UCJ) is a statutory body currently under the portfolio of the Ministry of Education. The UCJ is an oversight body which functions as an accrediting, awards and academic development body for degrees, diploma and certificate programmes.

Figure 1.1

FLOW CHART OF THE FORMAL PUBLIC EDUCATION SYSTEM
PRE - PRIMARY, PRIMARY
SECONDARY AND TERTIARY LEVELS

- ◆ PRINCIPAL'S DISCRETION
- GRADE SIX ACHIEVEMENT TEST (G.S.A.T. 11+)
- GRADE 9 ACHIEVEMENT TEST (G.N.A.T: 13+) / JUNIOR HIGH SCHOOL CERTIFICATE EXAM
- ⊙ COMMON ENTRANCE EXAMINATION (C.E.E 13+)
- ⊕ G.C.E "O" LEVEL
- ⊕ SECONDARY SCHOOL CERTIFICATE (S.S.C)
- 📖 CARIBBEAN EXAMINATIONS COUNCIL (C.X.C)
- ☑ G.C.E. 'A' LEVELS / C.A.P.E.
- ⊠ VOCATIONAL EXAMINATION
- ↻ FREE FLOW

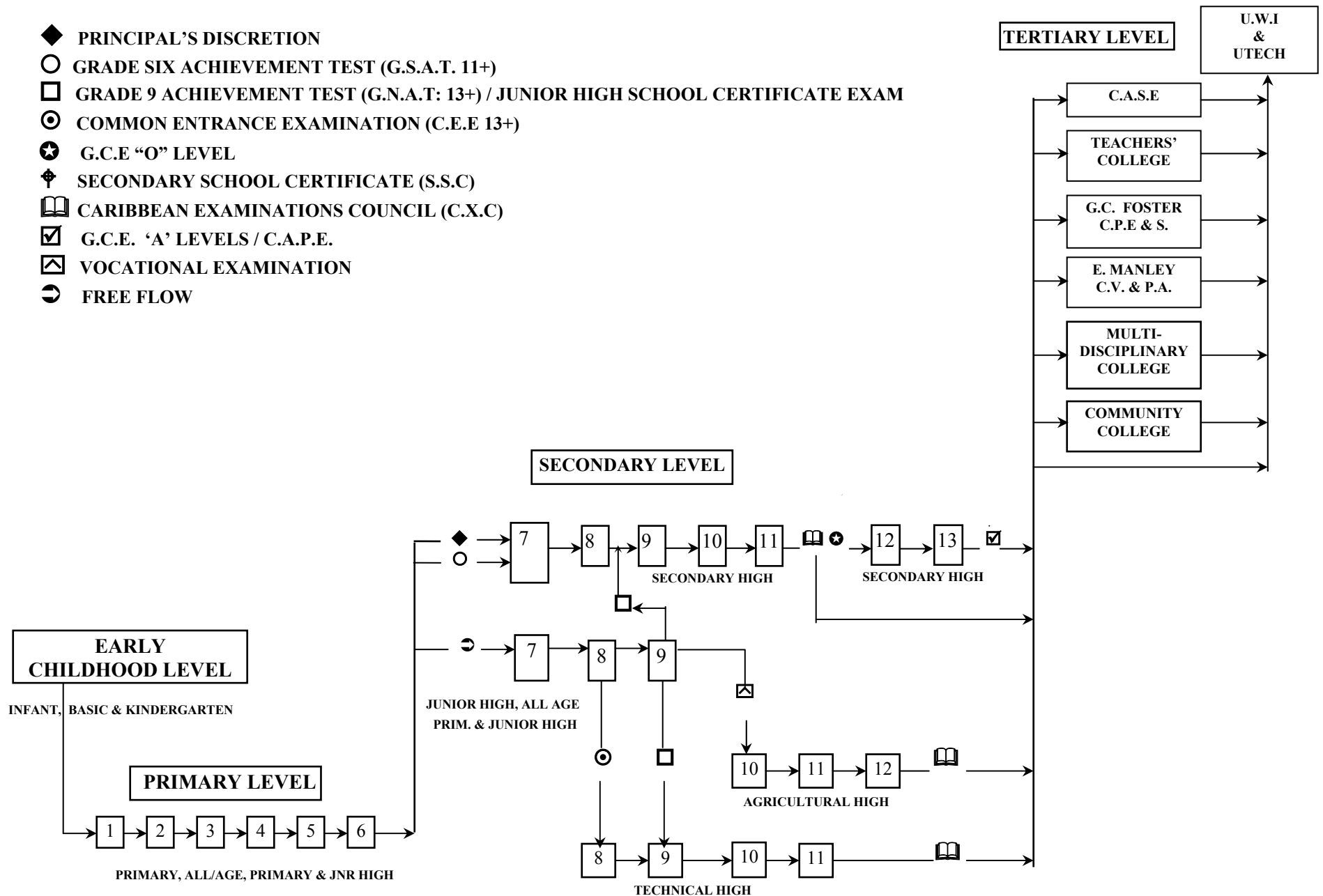

FIGURE 1.2

THE FORMAL PUBLIC EDUCATION SYSTEM IN JAMAICA: ORGANIZATION CHART

AGE BY SINGLE YEAR

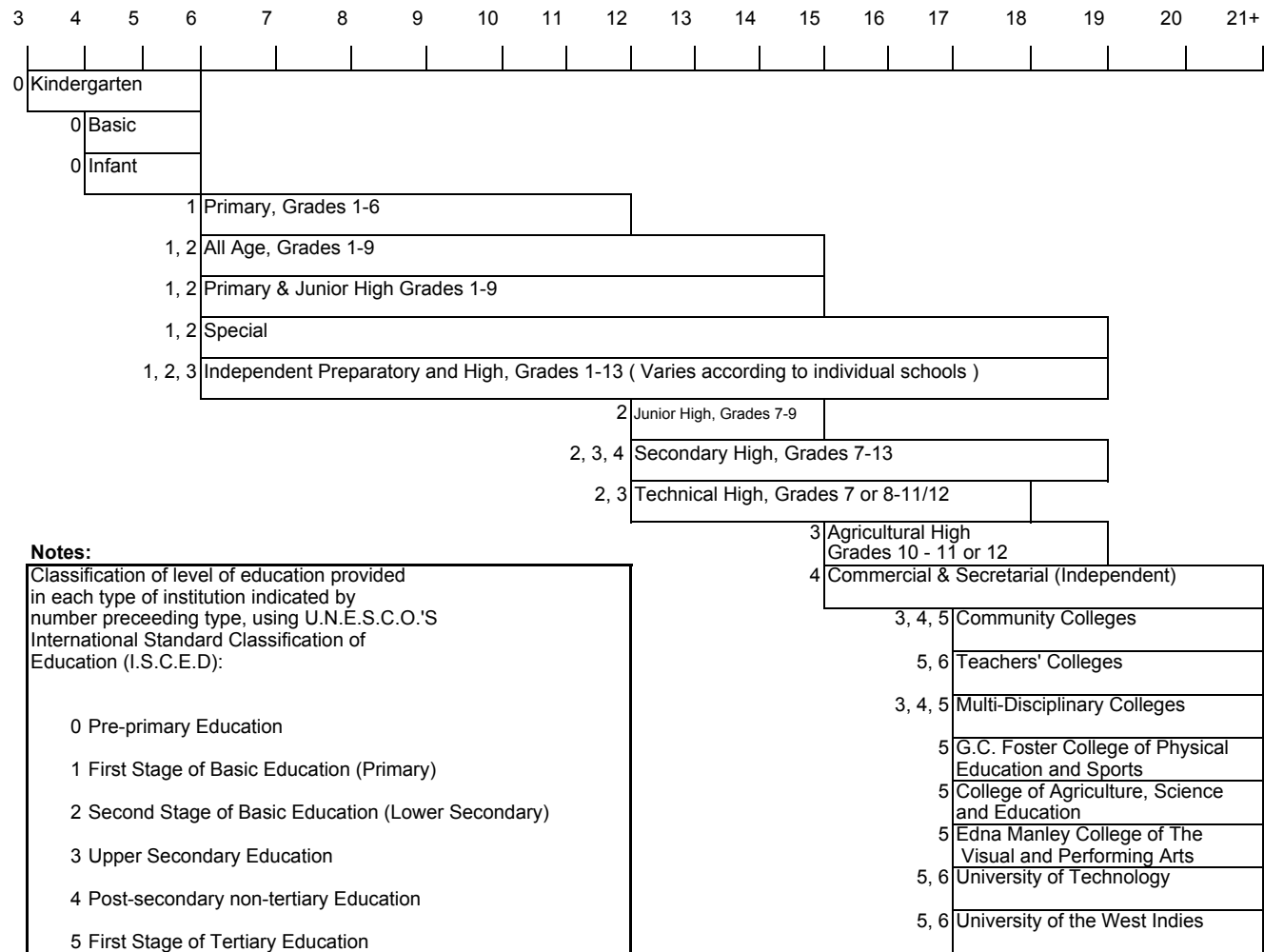

TABLE 1 -1

**SUMMARY OF TEACHING STAFF
BY TYPE OF EDUCATIONAL INSTITUTION
2008/2009**

SCHOOL TYPE	INSTITUTIONS*	TRAINED TEACHERS	UNTRAINED TEACHERS	NUMBER OF TEACHERS
PUBLIC INSTITUTIONS				
INFANT SCHOOLS	31	342	24	366
PRIMARY (Inclusive of Infant Departments)	546	7,406	773	8,179
ALL AGE (Grades 1 - 9 & Inclusive of Infant Departments)	159	1,888	212	2,100
JUNIOR HIGH and PRIMARY & JUNIOR HIGH (Grades 1 - 9 & Inclusive of Infant Departments)	87	2,522	278	2,800
SPECIAL SCHOOLS (Government Owned & Aided and Units)	17	229	117	346
SECONDARY HIGH	147	8,230	2,134	10,364
TECHNICAL HIGH	14	920	250	1,170
AGRICULTURAL HIGH	2	24	10	34
COMMUNITY COLLEGES	5	440
TEACHERS' COLLEGES	5	323
BETHLEHEM	1	59
MONEAGUE COLLEGE	1	72
EDNA MANLEY COLLEGE OF THE VISUAL & PERFORMING ARTS	1	121
COLLEGE OF AGRICULTURE, SCIENCE & EDUCATION	1	74
G.C. FOSTER COLLEGE OF PHYSICAL EDUCATION & SPORTS	1	29
UNIVERSITY OF TECHNOLOGY**	1	394
UNIVERSITY OF THE WEST INDIES (MONA)	1
SUB - TOTAL	1,020	21,561	3,798	26,871
INDEPENDENT INSTITUTIONS				
BASIC SCHOOLS (RECOGNISED)
BASIC SCHOOLS (UNRECOGNISED)
KINDERGARTEN /PREPARATORY	186
SECONDARY HIGH with PREPARATORY DEPARTMENT	31
SECONDARY HIGH	17
VOCATIONAL HIGH	62
COMMERCIAL/BUSINESS COLLEGE	106
SPECIAL	10	43	35	78
SUB - TOTAL	412	43	35	78

* Number of Institutions offering Education at the various levels

... not available

** data for University of Technology is for 2007/2008

TABLE 1-2a

**SUMMARY OF TEACHING STAFF
BY LEVEL AND TYPE OF EDUCATIONAL INSTITUTION
2008/2009**

	INSTITUTIONS*	TRAINED TEACHERS	UNTRAINED TEACHERS	NUMBER OF TEACHERS
EARLY CHILDHOOD				
INFANT SCHOOLS	31	342	24	366
PRIMARY (INFANT DEPARTMENTS)	77	226	33	259
ALL AGE (INFANT DEPARTMENTS)	14	27	4	31
PRIMARY & JUNIOR HIGH (INFANT DEPARTMENTS)	7	30	4	34
SUB - TOTAL	129	625	65	690
PRIMARY				
PRIMARY (GRADES 1 - 6)	546	7,180	740	7,920
ALL AGE (GRADES 1 - 6)	159	1,289	120	1,409
PRIMARY & JUNIOR HIGH (GRADES 1 - 6)	87	1,294	111	1,405
SUB - TOTAL	792	9,763	971	10,734
SPECIAL SCHOOLS				
GOVERNMENT / GOVERNMENT AIDED	10	205	71	276
SPECIAL EDUCATION UNIT	7	29	6	35
INDEPENDENT SPECIAL SCHOOLS	10	38	75	113
SUB - TOTAL	27	272	152	424

* Number of Institutions offering Education at the various levels

Table 1-2b

**SUMMARY OF TEACHING STAFF
BY LEVEL AND TYPE OF EDUCATIONAL INSTITUTION
2008/2009**

	INSTITUTIONS*	TRAINED TEACHERS	UNTRAINED TEACHERS	NUMBER OF TEACHERS
SECONDARY SCHOOLS				
ALL AGE (GRADES 7 - 9)	159	572	88	660
JUNIOR HIGH/PRIMARY & JUNIOR HIGH (GRADES 7 - 9)	87	1,198	163	1,361
SECONDARY HIGH	147	8,230	2,134	10,364
TECHNICAL HIGH	14	920	250	1,170
AGRICULTURAL HIGH	2	24	10	34
SUB - TOTAL	409	10,944	2,645	13,589
TERTIARY				
COMMUNITY COLLEGES	5	440
TEACHERS' COLLEGES	5	323
BETHLEHEM	1	59
MONEAGUE COLLEGE	1	72
EDNA MANLEY COLLEGE OF THE VISUAL & PERFORMING ARTS	1	121
COLLEGE OF AGRICULTURE, SCIENCE & EDUCATION	1	74
G.C. FOSTER COLLEGE OF PHYSICAL EDUCATION & SPORTS	1	29
UNIVERSITY OF TECHNOLOGY**	1	394
UNIVERSITY OF THE WEST INDIES	1
SUB - TOTAL	17	0	0	1,512
GRAND TOTAL	1,374	21,332	3,681	26,949

* Number of Institutions offering Education at the various levels

... data not available

** data for University of Technology is 2007/2008

TABLE 1-3a

**SUMMARY OF STUDENT ENROLMENT
BY LEVEL AND TYPE OF EDUCATIONAL INSTITUTION
2008/2009**

	INSTITUTIONS*	ENROLMENT			
		MALE	FEMALE	TOTAL	PERCENTAGE
EARLY CHILDHOOD					
INFANT SCHOOLS	31	3,984	3,925	7,909	1.4
PRIMARY (INFANT DEPARTMENTS)	63	2,181	2,215	4,396	0.8
ALL AGE (INFANT DEPARTMENTS)	28	218	197	415	0.1
PRIMARY & JUNIOR HIGH (INFANT DEPARTMENTS)	7	280	234	514	0.1
SUB - TOTAL	129	6,663	6,571	13,234	2.3
PRIMARY					
PRIMARY (GRADES 1 - 6)	546	100,629	98,470	199,099	34.3
ALL AGE (GRADES 1 - 6)	159	18,901	16,906	35,807	6.2
PRIMARY & JUNIOR HIGH (GRADES 1 - 6)	87	19,328	17,488	36,816	6.3
SUB - TOTAL	792	138,858	132,864	271,722	46.8
SPECIAL SCHOOLS					
GOVERNMENT / GOVERNMENT AIDED	10	1,699	979	2,678	0.5
SPECIAL EDUCATION UNIT	7	218	126	344	0.1
INDEPENDENT SPECIAL SCHOOLS	10	866	513	1,379	0.2
SUB - TOTAL	27	2,783	1,618	4,401	0.8

* Number of Institutions offering Education at the various levels

TABLE 1-3b

**SUMMARY OF STUDENT ENROLMENT
BY LEVEL AND TYPE OF EDUCATIONAL INSTITUTION
2008/2009**

	INSTITUTIONS*	ENROLMENT			
		MALE	FEMALE	TOTAL	PERCENTAGE
SECONDARY SCHOOLS					
ALL AGE (GRADES 7 - 9)	159	6,228	2,665	8,893	1.5
JUNIOR HIGH/PRIMARY & JUNIOR HIGH (GRADES 7 - 11)	87	13,690	8,284	21,974	3.8
SECONDARY HIGH	147	96,385	103,160	199,545	34.4
TECHNICAL HIGH	14	10,539	10,526	21,065	3.6
AGRICULTURAL HIGH	2	196	151	347	0.1
SUB - TOTAL	409	127,038	124,786	251,824	43.4
TERTIARY					
COMMUNITY COLLEGES	5	3,075	5,935	9,010	1.6
TEACHERS' COLLEGES	5	610	4,776	5,386	0.9
MONEAGUE COLLEGE	1	230	1,071	1,301	0.2
BETHLEHEM	1	74	646	720	0.1
EDNA MANLEY COLLEGE OF THE VISUAL & PERFORMING ARTS	1	220	253	473	0.1
COLLEGE OF AGRICULTURE, SCIENCE & EDUCATION	1	366	889	1,255	0.2
G.C. FOSTER COLLEGE OF PHYSICAL EDUCATION & SPORTS	1	270	296	566	0.1
UNIVERSITY OF TECHNOLOGY**	1	4,349	5,376	9,725	1.7
UNIVERSITY OF THE WEST INDIES	1	3,276	7,755	11,031	1.9
SUB - TOTAL	17	12,470	26,997	39,467	6.8
GRAND TOTAL	2,908	287,659	292,708	580,367	100.0

* Number of Institutions offering Education at the various levels
...data not submitted

** Data for University of Technology is for 2007/2008

TABLE 1 - 4

**DISTRIBUTION OF PUBLIC EDUCATIONAL INSTITUTIONS (EARLY CHILDHOOD, PRIMARY, SPECIAL)
BY TYPE AND PARISH
2008/2009**

PARISH	EARLY CHILDHOOD				PRIMARY			SPECIAL
	INFANT SCHOOLS	INFANT DEPT. (PRIMARY)	INFANT DEPT. (ALL - AGE)	INFANT DEPT. (PRIMARY & JNR HIGH)	PRIMARY	ALL - AGE	PRIMARY & JUNIOR HIGH	
Kingston	7	3	1	1	18	4	3	-
St. Andrew	-	10	1	3	49	13	16	5
St. Thomas	-	5	-	1	36	3	3	-
Portland	2	4	-	-	29	9	6	-
St. Mary	2	6	-	-	47	5	7	-
St. Ann	3	6	-	-	43	19	6	2
Trelawny	1	6	-	-	25	5	2	-
St. James	3	5	3	-	21	15	7	-
Hanover	2	-	1	-	18	12	3	-
Westmoreland	2	6	3	-	32	18	5	1
St. Elizabeth	-	1	2	-	57	13	5	-
Manchester	3	5	1	1	38	14	6	1
Clarendon	2	14	1	1	59	16	11	-
St. Catherine	4	6	1	-	74	13	7	1
TOTAL	31	77	14	7	546	159	87	10

TABLE 1 - 5

**DISTRIBUTION OF PUBLIC EDUCATIONAL INSTITUTIONS (SECONDARY, TERTIARY)
BY TYPE AND PARISH
2008/2009**

PARISH	SECONDARY					TERTIARY		
	ALL AGE	PRIMARY & JUNIOR HIGH	SECONDARY HIGH	TECHNICAL HIGH	AGRICULTURAL HIGH	COMMUNITY COLLEGE	TEACHERS' COLLEGE	OTHER INSTITUTIONS
Kingston	4	3	12	2	-	-	-	-
St. Andrew	13	16	27	1	-	1	3	U.T.E.C.H., U.W.I., E.M.C.V & P.A.
St. Thomas	3	3	5	1	-	-	-	-
Portland	9	6	5	-	-	-	-	C.A.S.E.
St. Mary	5	7	8	1	-	-	-	-
St. Ann	19	6	7	1	-	1	-	MONEAGUE
Trelawny	5	2	7	-	-	-	-	-
St. James	15	7	10	1	-	1	1	-
Hanover	12	3	5	1	1	-	-	-
Westmoreland	18	5	6	1	-	-	-	-
St. Elizabeth	13	5	9	1	1	-	-	BETHLEHEM
Manchester	14	6	10	1	-	-	1	-
Clarendon	16	11	16	1	-	1	-	-
St. Catherine	13	7	20	2	-	1	-	G.C. FOSTER COLLEGE
TOTAL	159	87	147	14	2	5	5	7

TABLE 1-6a

**DISTRIBUTION OF PUBLIC EDUCATIONAL INSTITUTIONS
INFANT, PRIMARY, ALL - AGE, PRIMARY & JUNIOR HIGH AND SPECIAL
BY REGION AND PARISH
2008/2009**

Region	Parish	Infant	Primary	All - Age	Primary & Junior High	Special	Sub Total
Kingston	Kingston	7	18	4	3	-	32
	St. Andrew	-	49	13	16	5	83
	St. Thomas	-	12	3	1	-	16
	Total	7	79	20	20	5	131
Port Antonio	St. Thomas	-	24	-	2	-	26
	Portland	2	29	9	6	-	46
	St. Mary	1	27	3	4	-	35
	Total	3	80	12	12	-	107
Brown's Town	St. Mary	1	20	2	3	-	26
	St. Ann	3	43	19	6	2	73
	Trelawny	1	25	5	2	-	33
	Total	5	88	26	11	2	132
Montego Bay	St. James	3	21	15	7	-	46
	Hanover	2	18	12	3	-	35
	Westmoreland	2	32	18	5	1	58
	Total	7	71	45	15	1	139
Mandeville	St. Elizabeth	-	57	13	5	-	75
	Manchester	3	38	14	6	1	62
	Total	3	95	27	11	1	137
Old Harbour	Clarendon	2	59	16	11	-	88
	St. Catherine	4	74	13	7	1	99
	Total	6	133	29	18	1	187
JAMAICA	GRAND TOTAL	31	546	159	87	10	833

TABLE 1-6b

**DISTRIBUTION OF PUBLIC EDUCATIONAL INSTITUTIONS
SECONDARY & TERTIARY
BY REGION AND PARISH
2008/2009**

Region	Parish	SECONDARY			TERTIARY			TOTAL
		Secondary High	Technical High	Vocational High	Community College	Teachers' College	Other Institutions	
Kingston	Kingston	12	2	-	-	-	-	46
	St. Andrew	27	1	-	1	3	3	118
	St. Thomas	1	-	-	-	-	-	17
	Total	40	3	-	1	3	3	181
Port Antonio	St. Thomas	4	1	-	-	-	-	31
	Portland	5	-	-	-	-	1	52
	St. Mary	5	1	-	-	-	-	41
	Total	14	2	-	-	-	1	124
Brown's Town	St. Mary	3	-	-	-	-	-	29
	St. Ann	7	1	-	1	-	1	83
	Trelawny	7	-	-	-	-	-	40
	Total	17	1	-	1	-	1	152
Montego Bay	St. James	10	1	-	1	1	-	59
	Hanover	5	1	1	-	-	-	42
	Westmoreland	6	1	-	-	-	-	65
	Total	21	3	1	1	1	-	166
Mandeville	St. Elizabeth	9	1	1	-	-	1	87
	Manchester	10	1	-	-	1	-	74
	Clarendon	3	-	-	1	-	-	4
	Total	22	2	1	1	1	1	165
Old Harbour	Clarendon	13	1	-	-	-	-	102
	St. Catherine	20	2	-	1	-	1	123
	Total	33	3	-	1	-	1	225
JAMAICA	GRAND TOTAL	147	14	2	5	5	7	1013

TABLE 1 - 7

**DISTRIBUTION OF INDEPENDENT INSTITUTIONS BY PARISH
2008/2009**

PARISH	KINDERGARTEN/ PREPARATORY	PREPARATORY/ SECONDARY HIGH	SECONDARY HIGH	VOCATIONAL HIGH	COMMERCIAL/ BUSINESS COLLEGE	SPECIAL	UNIVERSITY	TOTAL
Kingston	4	-	3	6	5	2	-	20
St. Andrew	61	10	5	29	28	3	-	136
St. Thomas	7	-	1	-	1	-	-	9
Portland	7	1	-	-	3	-	-	11
St. Mary	3	1	-	-	1	-	-	5
St. Ann	12	4	-	4	4	-	-	24
Trelawny	3	-	-	-	-	-	-	3
St. James	26	10	3	6	17	1	-	63
Hanover	4	-	-	-	1	-	-	5
Westmoreland	11	1	-	2	6	-	-	20
St. Elizabeth	9	-	2	1	4	1	-	17
Manchester	12	1	2	5	11	2	1	34
Clarendon	6	1	1	6	7	1	-	22
St. Catherine	21	2	-	3	18	-	-	44
TOTAL	186	31	17	62	106	10	1	413

TABLE 1 - 8

**NUMBER OF PUBLIC EDUCATIONAL INSTITUTIONS WITH SHIFT
BY SCHOOL TYPE & PARISH
2008/2009**

PARISH	PRIMARY	ALL AGE	PRIMARY & JUNIOR HIGH	SECONDARY HIGH	TECHNICAL HIGH	TOTAL
Kingston	-	-	-	2	-	2
St. Andrew	3	-	3	5	-	11
St. Thomas	-	-	-	2	-	2
Portland	2	1	-	1	-	4
St. Mary	-	-	1	3	-	4
St. Ann	2	3	2	2	1	10
Trelawny	-	1	-	3	-	4
St. James	-	-	5	3	-	8
Hanover	-	-	2	1	-	3
Westmoreland	3	-	1	2	-	6
St. Elizabeth	-	-	2	4	-	6
Manchester	1	-	6	2	-	9
Clarendon	4	1	6	1	-	12
St. Catherine	13	3	6	9	-	31
TOTAL	28	9	34	40	1	112



TEACHER

STATISTICS

TEACHER STATISTICS

OVERVIEW

For the academic year 2008/2009, the Ministry of Education employed 25,013 teachers in the public formal education system. This figure represents an increase of 1.7 percent in the number of teachers employed when compared with the previous year. The largest increase in employment was at the secondary level. All other school types showed an increase in the number of teachers employed except for the All Age and Primary and Junior High schools, which showed a 0.52 percent and 0.5 percent decline respectively.

Analysis of the data by professional qualification continued to show a ratio of approximately 6 trained teachers to 1 untrained teacher. Teachers with college training only accounted for the largest proportion (50.2 percent) of trained teachers in the system. This represents a decline of 4.7 percent over that of the previous year. The data also indicates that the percentage of teachers who were trained university graduates grew from 19.8 percent in 2002 to 34.2 percent in 2008. This however, may be explained by an increase in the percentage of trained graduates from 31.8 to 34.1 over the same period. Of the 3,681 untrained teachers in the system, approximately 43.2 percent had secondary education only. Of significance, the number of untrained secondary school graduate teachers has declined from 8.8 percent in 2002 to 6.4 percent in 2008.

In comparison with the previous year, all parishes indicated an increase in the number of teachers employed, except for St. Elizabeth and Portland which showed a 0.7 percent and 1.2 percent decrease respectively. St. Catherine, followed by Kingston and St. James had the largest number of teachers employed.

Women continue to outnumber men at a ratio of nine to one, with female teachers accounting for 79 percent of the teaching personnel. At the primary level there was a 1.9 percent increase in the number of females teachers employed during the period. At the early childhood level, male teachers were outnumbered by 30 to 1 in infant schools and departments. Of the 19,774 females in the public

1. Teacher pupil ratio excludes teachers on leave and administrators

TEACHER STATISTICS

school system, 6 percent were principals and vice principals compared with 9 percent of the 5,262 males. This indicates that while there are more female teachers than male teachers, the proportion of male teachers at the leadership level is greater.

The data also showed that at the primary level there were 10,734 teachers providing instruction to 271,722 pupils. The teacher pupil ratio reflected at this level was 29:1¹. The data indicates that as much as 85.8 percent of the schools at the primary level were operating with ratios below 35:1. Approximately 12.0 percent of the schools had an average of 36 or more pupils to 1 teacher and 2.2 percent of schools had the standard ratio of 35 pupils to 1 teacher.

Distribution of Pupil : Teacher Ratios at the Primary

No of Pupils: 1 Teacher	School (Percent)
20 and less	18.4
21 - 34	67.4
35	2.2
36 - 50	11.1
51 and over	0.9
Total	100

The Standard number of pupils to one teacher is 35

1. Teacher pupil ratio excludes teachers on leave and administrators

FIGURE 2.1

Distribution of Teachers by School Type 2008/2009

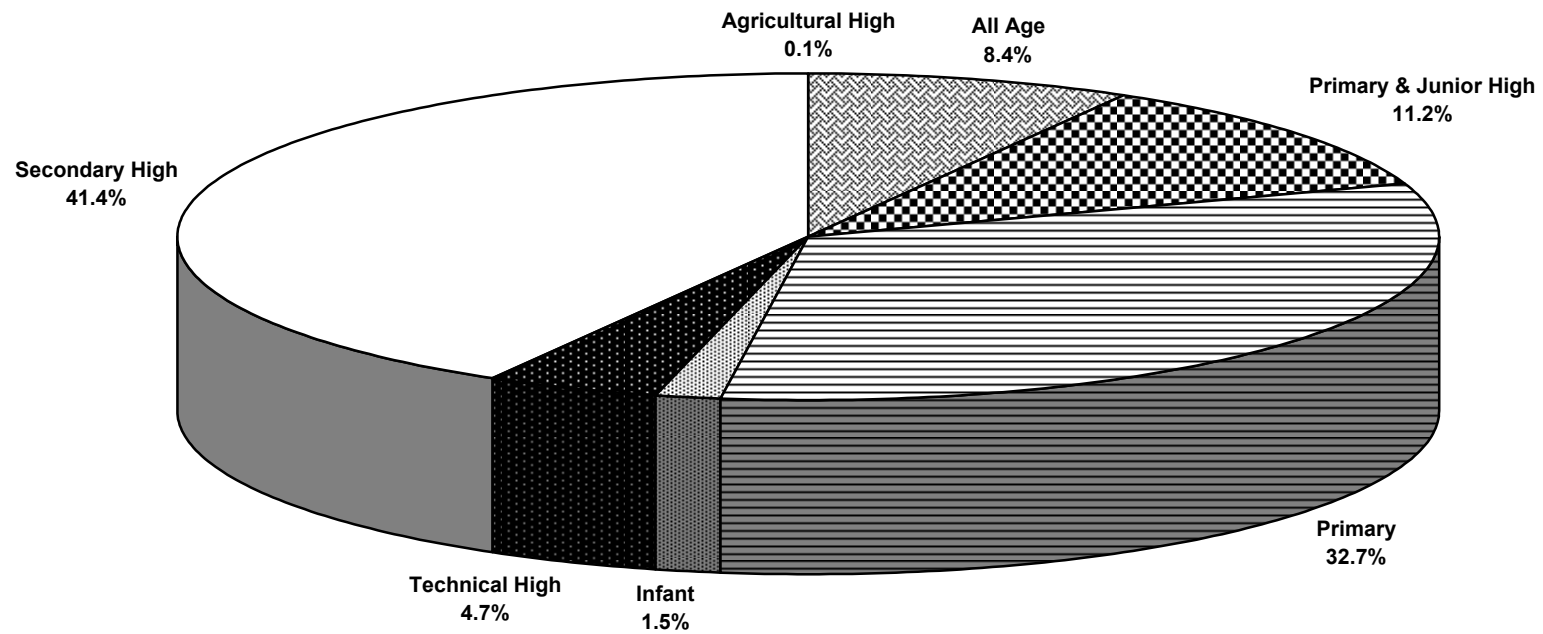

FIGURE 2.2

Distribution of Teachers by Qualification 2008/2009

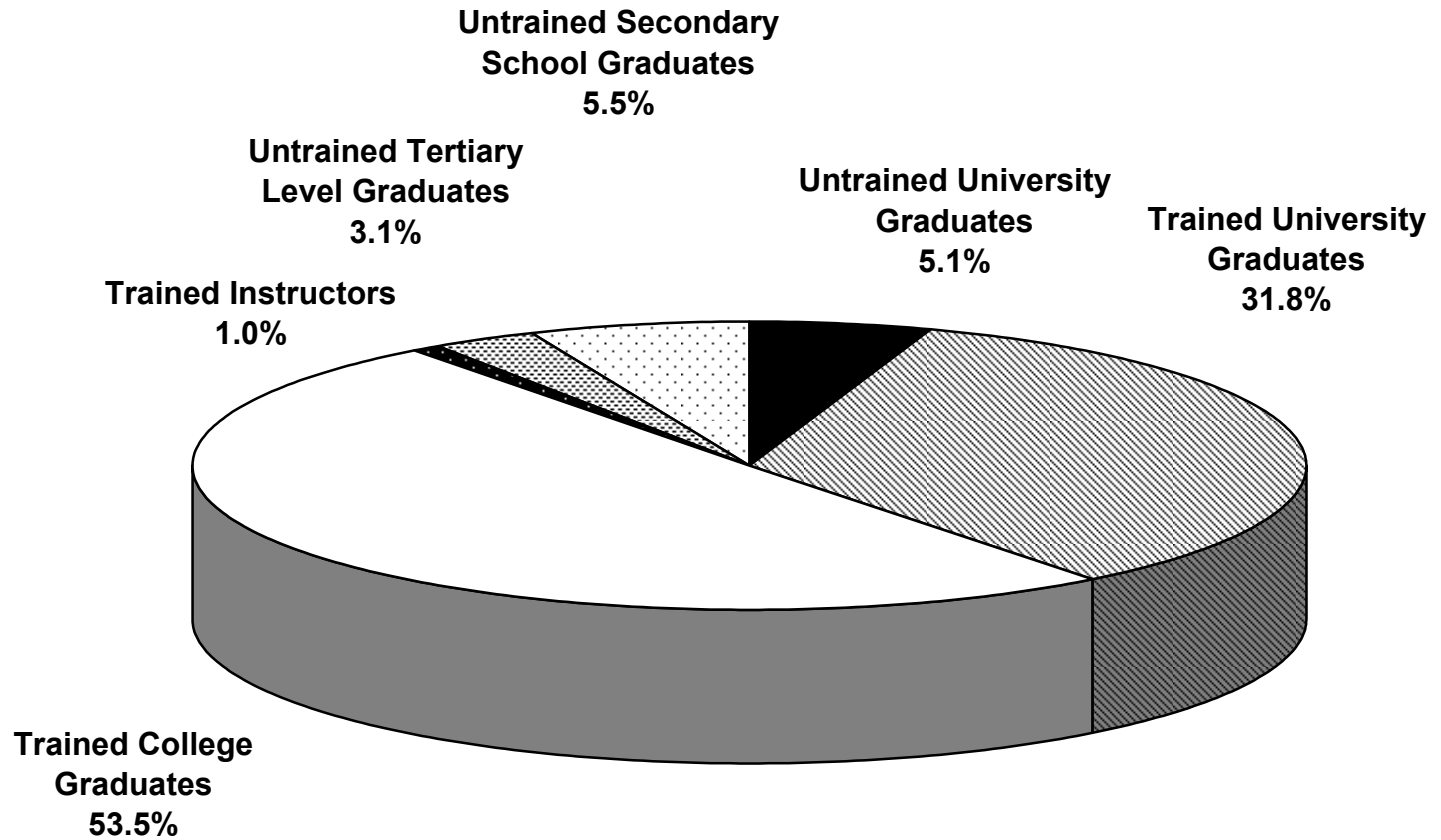

TABLE 2-1

**Teachers In Infant, Primary, and Secondary Level Schools
By Type of Institution, Sex and Parish
2008/2009**

Parish	Infant Schools		Primary Schools		All Age Schools		Primary & Junior High Schools		Secondary High Schools		Technical High Schools		Vocational/ Agricultural Schools		Total		Grand Total
	M	F	M	F	M	F	M	F	M	F	M	F	M	F	M	F	
Kingston	1	52	46	403	6	57	33	128	303	635	49	74			438	1349	1787
St. Andrew			130	1105	25	142	88	525	587	1441	42	46			872	3259	4131
St. Thomas			49	373		35	13	72	114	215	25	50			201	745	946
Portland		21	44	258	23	110	13	75	112	231					192	695	887
St. Mary		16	62	333	10	53	33	138	126	314	16	41			247	895	1142
St. Ann		31	58	447	34	230	23	134	138	337	38	99			291	1278	1569
Trelawny		11	29	239	9	91	8	38	107	254					153	633	786
St. James	2	49	61	417	18	155	25	196	200	501	38	55			344	1373	1717
Hanover		14	21	171	16	83	4	76	87	218	20	46	6	7	154	615	769
Westmoreland		20	43	384	24	169	20	76	125	315	22	44			234	1008	1242
St. Elizabeth			66	470	30	133	23	110	185	379	33	64	10	11	347	1167	1514
Manchester		47	47	390	22	132	44	235	162	397	35	38			310	1239	1549
Clarendon		26	98	758	49	234	69	297	354	749	27	70			597	2134	2731
St. Catherine		76	189	1488	26	184	48	256	543	1235	69	129			875	3368	4243
Total	3	363	943	7236	292	1808	444	2356	3143	7221	414	756	16	18	5255	19758	25013
Grand Total	366		8179		2100		2800		10364		1170		34		25013		

TABLE 2-2

Teachers In Infant, Primary and Secondary Schools By Post, Sex and Parish

2008/2009

Parish	Principal		Vice Principal		Senior Teacher		Trained Teacher		Pre-Trained Teacher		Specialist		Master Teacher		Total		Grand Total
	M	F	M	F	M	F	M	F	M	F	M	F	M	F	M	F	
Kingston	16	29	12	38	52	239	204	813	106	211	48	18		1	438	1349	1787
St. Andrew	28	84	21	82	121	563	473	2037	165	444	63	43	1	6	872	3259	4131
St. Thomas	8	40	4	17	30	116	100	466	40	96	19	9		1	201	745	946
Portland	16	34	3	23	20	99	101	451	40	83	12	5			192	695	887
St. Mary	30	41	7	25	26	137	116	555	45	123	23	14			247	895	1142
St. Ann	28	52	3	38	42	231	150	809	52	138	16	10			291	1278	1569
Trelawny	16	25	8	19	22	90	73	409	27	84	7	6			153	633	786
St. James	24	35	9	40	57	236	182	888	46	160	24	12	2	2	344	1373	1717
Hanover	16	27	3	21	26	82	66	367	33	111	10	6		1	154	615	769
Westmoreland	17	45	4	26	36	161	131	655	26	114	20	6		1	234	1008	1242
St. Elizabeth	29	59	6	36	51	207	157	735	76	115	27	14	1	1	347	1167	1514
Manchester	33	46	8	44	51	233	142	809	43	99	33	7		1	310	1239	1549
Clarendon	44	65	21	62	81	354	330	1436	80	188	41	26		3	597	2134	2731
St. Catherine	50	74	19	92	113	574	459	2192	169	367	65	69			875	3368	4243
Total	355	656	128	563	728	3322	2684	12622	948	2333	408	245	4	17	5255	19758	25013
Grand Total	1011		691		4050		15306		3281		653		21		25013		

TABLE 2-3

Teachers In Infant,Primary and Secondary Schools By Qualification, Sex and Parish

2008/2009

Parish	Trained University Graduate		Untrained University Graduate		Trained College Graduate		* Untrained Tertiary Level Graduate		Trained Instructor		Untrained Secondary School Graduate		Total		Grand Total
	M	F	M	F	M	F	M	F	M	F	M	F	M	F	
Kingston	113	557	55	133	183	556	22	22	23	11	42	70	438	1349	1787
St. Andrew	261	1388	76	233	394	1377	57	49	18	15	66	197	872	3259	4131
St. Thomas	46	233	16	26	98	404	19	14	3	4	19	64	201	745	946
Portland	48	224	19	35	89	375	19	16	4	5	13	40	192	695	887
St. Mary	55	265	12	35	124	493	25	16	7	3	24	83	247	895	1142
St. Ann	72	407	23	40	140	713	21	24	11	6	24	88	291	1278	1569
Trelawny	38	204	8	19	75	338	8	14	4	2	20	56	153	633	786
St. James	93	505	22	65	187	695	22	24	8	4	12	80	344	1373	1717
Hanover	36	174	9	43	74	321	19	27	3	1	13	49	154	615	769
Westmoreland	74	348	6	27	121	540	9	22	9	2	15	69	234	1008	1242
St. Elizabeth	68	381	32	30	169	652	29	27	12	5	37	72	347	1167	1514
Manchester	82	519	18	47	152	611	29	32	12	2	17	28	310	1239	1549
Clarendon	168	794	23	78	308	1131	45	33	23	5	30	93	597	2134	2731
St. Catherine	211	1181	61	137	451	1790	59	58	16	8	77	194	875	3368	4243
Total	1365	7180	380	948	2565	9996	383	378	153	73	409	1183	5255	19758	25013
Grand Total	8545		1328		12561		761		226		1592		25013		

* Certificate/Diploma

TABLE 2-4

**Teachers In Infant, Primary and Secondary Schools By Qualification, Sex and Region
2008/2009**

Region	Trained University Graduate		Untrained University Graduate		Trained College Graduate		* Untrained Tertiary Level Graduate		Trained Instructor		Untrained Secondary School Graduate		Total		Grand Total
	M	F	M	F	M	F	M	F	M	F	M	F	M	F	
Kingston	383	1988	134	378	593	2063	83	75	41	27	113	293	1347	4824	6171
Port Antonio	113	559	42	78	236	948	50	37	11	10	39	133	491	1765	2256
Brown's Town	137	731	33	65	274	1245	38	43	18	9	56	172	556	2265	2821
Montego Bay	203	1027	37	135	382	1556	50	73	20	7	40	198	732	2996	3728
Mandeville	165	944	53	81	348	1322	64	60	27	7	61	109	718	2523	3241
Old Harbour	364	1931	81	211	732	2862	98	90	36	13	100	278	1411	5385	6796
Total	1365	7180	380	948	2565	9996	383	378	153	73	409	1183	5255	19758	25013
Grand Total	8545		1328		12561		761		226		1592		25013		

* Certificate/Diploma

TABLE 2-5

Teachers In Infant Schools By Post, Sex and Parish

2008/2009

Parish	Principal		Vice Principal		Senior Teacher		Trained Teacher		Pre-Trained Teacher		Specialist		Master Teacher		Total		Grand Total
	M	F	M	F	M	F	M	F	M	F	M	F	M	F	M	F	
Kingston		7		1		7		35	1	2					1	52	53
Portland		2		1		5		12		1						21	21
St. Mary		3				2		10		1						16	16
St. Ann		3		1		5		21		1						31	31
Trelawny		1		1				9								11	11
St. James		3		1		9	2	34		2					2	49	51
Hanover		2				2		10								14	14
Westmoreland		2		1		2		12		3						20	20
Manchester		3		1		6		35		2						47	47
Clarendon		2				3		16		5						26	26
St. Catherine		5		3		14		49		5						76	76
Total		33		10		55	2	243	1	22					3	363	366
Grand Total		33		10		55		245		23						366	

TABLE 2-6

**Teachers In Infant Schools By Qualification, Sex and Parish
2008/2009**

Parish	Trained University Graduate		Untrained University Graduate		Trained College Graduate		* Untrained Tertiary Level Graduate		Trained Instructor		Untrained Secondary School Graduate		Total		Grand Total	
	M	F	M	F	M	F	M	F	M	F	M	F	M	F		
Kingston		20				30		1				1	1	1	52	53
Portland		9				11							1		21	21
St. Mary		7				8							1		16	16
St. Ann		4				26							1		31	31
Trelawny				1		10									11	11
St. James		16			2	31							2	2	49	51
Hanover		4				10									14	14
Westmoreland		5				12							3		20	20
Manchester		22		2		23									47	47
Clarendon		3		2		17				1			3		26	26
St. Catherine		33		1		38							4		76	76
Total		123		6	2	216		1		1		1	16	3	363	366
Grand Total		123		6		218		1		1		17			366	

* Certificate/Diploma

TABLE 2-7

Teachers In Infant Depts of Primary Schools By Post, Sex and Parish

2008/2009

Parish	Principal		Vice Principal		Senior Teacher		Trained Teacher		Pre-Trained Teacher		Specialist		Master Teacher		Total		Grand Total
	M	F	M	F	M	F	M	F	M	F	M	F	M	F	M	F	
Kingston		1				1		12	1	1					1	15	16
St. Andrew		2		1		6	1	19	1	3	1				3	31	34
St. Thomas						1		5		2						8	8
Portland	1	1						6		3					1	10	11
St. Mary	3					2		4		2					3	8	11
St. Ann		2				2		12		2						18	18
Trelawny		2		1		2		11		2						18	18
St. James	1	2		1		6		14	1	4					2	27	29
Hanover								2								2	2
Westmoreland	1	2				2	1	17		1					2	22	24
St. Elizabeth	1							8		2					1	10	11
Manchester		2				4		18								24	24
Clarendon		1				5		25		1						32	32
St. Catherine	1					3	1	11		5					2	19	21
Total	8	15		3		34	3	164	3	28	1				15	244	259
Grand Total		23		3		34		167		31		1				259	

TABLE 2-8

Teachers In Infant Depts of Primary Schools By Qualification, Sex and Parish

2008/2009

Parish	Trained University Graduate		Untrained University Graduate		Trained College Graduate		* Untrained Tertiary Level Graduate		Trained Instructor		Untrained Secondary School Graduate		Total		Grand Total	
	M	F	M	F	M	F	M	F	M	F	M	F	M	F		
Kingston		3				11		1				1		1	15	16
St. Andrew		10			1	18		1				1	3	3	31	34
St. Thomas						6						2			8	8
Portland		2	1			5						3		1	10	11
St. Mary	2	2			1	4						2		3	8	11
St. Ann		4				12						2			18	18
Trelawny		2		1		14						1			18	18
St. James	1	6				17						1	4	2	27	29
Hanover						2									2	2
Westmoreland		4			2	17						1		2	22	24
St. Elizabeth	1	5				3		1				1		1	10	11
Manchester		9				15									24	24
Clarendon		1				30						1			32	32
St. Catherine	1	3			1	11		1				4		2	19	21
Total	5	51	1	1	5	165	1	3				3	24	15	244	259
Grand Total		56		2		170		4				27			259	

* Certificate/Diploma

TABLE 2-10

**Teachers In Infant Depts of All Age Schools By Qualification, Sex and Parish
2008/2009**

Parish	Trained University Graduate		Untrained University Graduate		Trained College Graduate		* Untrained Tertiary Level Graduate		Trained Instructor		Untrained Secondary School Graduate		Total		Grand Total
	M	F	M	F	M	F	M	F	M	F	M	F	M	F	
Kingston	1					2							1	2	3
St. Andrew						1								1	1
St. James						3			1			1		5	5
Hanover						2								2	2
Westmoreland		2				3						1		6	6
St. Elizabeth		1				5								6	6
Manchester						1						1		2	2
Clarendon		3				2								5	5
St. Catherine						1								1	1
Total	1	6				20			1			3	1	30	31
Grand Total		7				20			1			3		31	

* Certificate/Diploma

TABLE 2-11

**Teachers In Infant Depts of Primary & Junior High By Post, Sex and Parish
2008/2009**

Parish	Principal		Vice Principal		Senior Teacher		Trained Teacher		Pre-Trained Teacher		Specialist		Total		Grand Total	
	M	F	M	F	M	F	M	F	M	F	M	F	M	F		
Kingston	1					4		4		2				1	10	11
St. Andrew	1			1		3	1	6		2				2	12	14
St. Thomas								2							2	2
Manchester								4							4	4
Clarendon							1	2						1	2	3
Total	2			1		7	2	18		4				4	30	34
Grand Total	2		1		7		20		4					34		

**TABLE 2-12 Teachers In Infant Depts of Primary & Junior High By Qualification, Sex and Parish
2008/2009**

Parish	Trained University Graduate		Untrained University Graduate		Trained College Graduate		* Untrained Tertiary Level Graduate		Untrained Secondary School Graduate		Total		Grand Total
	M	F	M	F	M	F	M	F	M	F	M	F	
Kingston	1	3				5				2	1	10	11
St. Andrew	2	3		1		7				1	2	12	14
St. Thomas		1				1						2	2
Manchester						4						4	4
Clarendon	1					2					1	2	3
Total	4	7		1		19				3	4	30	34
Grand Total		11		1		19				3		34	

* Certificate/Diploma

TABLE 2-13

Teachers In Primary Schools By Post, Sex and Parish

2008/2009

Parish	Principal		Vice Principal		Senior Teacher		Trained Teacher		Pre-Trained Teacher		Specialist		Master Teacher		Total		Grand Total
	M	F	M	F	M	F	M	F	M	F	M	F	M	F	M	F	
Kingston	4	11	2	15	4	76	22	250	9	33	4	3			45	388	433
St. Andrew	9	40	2	30	13	151	75	748	22	102	6	1		2	127	1074	1201
St. Thomas	4	32	2	9	3	43	33	248	6	33	1				49	365	414
Portland	8	18		8	3	25	25	178	7	19					43	248	291
St. Mary	20	23	2	7	3	42	25	218	8	35	1				59	325	384
St. Ann	14	28	1	13	4	73	34	277	3	38	2				58	429	487
Trelawny	10	14	2	4	2	29	11	157	4	16		1			29	221	250
St. James	9	11	4	9	9	63	34	264	3	43					59	390	449
Hanover	10	8		7	1	22	9	105	1	27					21	169	190
Westmoreland	8	20		9	6	57	25	259	2	17					41	362	403
St. Elizabeth	15	41		11	6	75	39	299	5	34					65	460	525
Manchester	15	24		15	3	61	26	250	3	14		1		1	47	366	413
Clarendon	18	41	4	23	5	109	61	495	6	52	4	3		3	98	726	824
St. Catherine	27	47	6	44	15	242	104	997	26	132	9	7			187	1469	1656
Total	171	358	25	204	77	1068	523	4745	105	595	27	16		6	928	6992	7920
Grand Total	529		229		1145		5268		700		43		6		7920		

TABLE 2-14

**Teachers In Primary Schools By Qualification, Sex and Parish
2008/2009**

Parish	Trained University Graduate		Untrained University Graduate		Trained College Graduate		* Untrained Tertiary Level Graduate		Trained Instructor		Untrained Secondary School Graduate		Total		Grand Total
	M	F	M	F	M	F	M	F	M	F	M	F	M	F	
Kingston	10	147	3	13	25	207	3	1			4	20	45	388	433
St. Andrew	28	361	1	22	73	602	6	8	2	3	17	78	127	1074	1201
St. Thomas	8	87	1	3	34	243	1	2		1	5	29	49	365	414
Portland	8	68	4	3	27	161					4	16	43	248	291
St. Mary	15	81	4		34	209	2	2			4	33	59	325	384
St. Ann	22	124	1	4	32	265	1	6		1	2	29	58	429	487
Trelawny	10	66	2		13	139	1	2			3	14	29	221	250
St. James	21	115		3	35	232	1	2			2	38	59	390	449
Hanover	8	44	1	14	11	94		2			1	15	21	169	190
Westmoreland	15	112		3	24	231	1	4			1	12	41	362	403
St. Elizabeth	16	116	1	4	44	307		7			4	26	65	460	525
Manchester	18	151	2	3	26	200		8			1	4	47	366	413
Clarendon	32	245	1	5	58	426	4	7	1	2	2	41	98	726	824
St. Catherine	51	419	8	30	105	910	3	17	3	2	17	91	187	1469	1656
Total	262	2136	29	107	541	4226	23	68	6	9	67	446	928	6992	7920
Grand Total	2398		136		4767		91		15		513		7920		

* Certificate/Diploma

TABLE 2-15

Teachers In All Age Schools Grades 1-6 By Post, Sex and Parish

2008/2009

Parish	Principal		Vice Principal		Senior Teacher		Trained Teacher		Pre-Trained Teacher		Specialist		Master Teacher		Total		Grand Total
	M	F	M	F	M	F	M	F	M	F	M	F	M	F	M	F	
Kingston		1				5	1	30	1	4					2	40	42
St. Andrew		8		3	1	11	7	58	2	15					10	95	105
St. Thomas						3		10		2						15	15
Portland	2	1		1	1	9	11	49	2	4					16	64	80
St. Mary		4		2		8	2	33	2	2		1		4	50	54	
St. Ann	4	2		5	1	27	8	123		15				13	172	185	
Trelawny	2	1		2	1	12	1	45	1	5				5	65	70	
St. James		2		3	1	23	6	72	1	5				8	105	113	
Hanover	1	5		3	1	11	3	40	1	6				6	65	71	
Westmoreland		3		3	2	17	9	87		14				11	124	135	
St. Elizabeth		3		5	2	14	7	61	1	9	1			11	92	103	
Manchester		5		5		17	4	62		4		1		4	94	98	
Clarendon	2	6	3	7	4	28	15	125	2	6		1		26	173	199	
St. Catherine	4	7		3		19	4	91	1	10				9	130	139	
Total	15	48	3	42	14	204	78	886	14	101	1	3		125	1284	1409	
Grand Total		63		45		218		964		115		4			1409		

TABLE 2-16

**Teachers In All Age Schools Grades 1-6 By Qualification, Sex and Parish
2008/2009**

Parish	Trained University Graduate		Untrained University Graduate		Trained College Graduate		* Untrained Tertiary Level Graduate		Trained Instructor		Untrained Secondary School Graduate		Total		Grand Total
	M	F	M	F	M	F	M	F	M	F	M	F	M	F	
Kingston		13			1	23	1					4	2	40	42
St. Andrew	2	28		2	6	52						2	13	10	105
St. Thomas		1				12						2		15	15
Portland	5	17			9	43	1					1	4	16	80
St. Mary		13		1	2	34	1	1				1	1	4	54
St. Ann	6	39		4	7	116		1		1			11	13	185
Trelawny	1	27			3	33						1	5	5	70
St. James	1	33	1	1	6	67			1				3	8	113
Hanover	1	20		2	4	38			1			1	4	6	71
Westmoreland	2	18		2	9	92							8	11	135
St. Elizabeth	4	15		2	6	66		1		1		1	7	11	103
Manchester	1	32			3	58			3				1	4	98
Clarendon	5	57		1	18	109			4	1		2	2	26	199
St. Catherine	6	34	1		2	86							10	9	139
Total	34	347	2	15	76	829	3	16	1	2	9	75	125	1284	1409
Grand Total	381		17		905		19		3		84		1409		

* Certificate/Diploma

TABLE 2-17

Teachers In All Age Schools Grades 7-9 By Post, Sex and Parish

2008/2009

Parish	Principal		Vice Principal		Senior Teacher		Trained Teacher		Pre-Trained Teacher		Specialist		Master Teacher		Total		Grand Total
	M	F	M	F	M	F	M	F	M	F	M	F	M	F	M	F	
Kingston	2			2		2		9	1	1		1			3	15	18
St. Andrew	2	7		2	2	7	5	23	4	6	2			1	15	46	61
St. Thomas		3				3		11		3						20	20
Portland	1	5		4	1	2	3	26	1	8	1	1			7	46	53
St. Mary	1					1	5	2							6	3	9
St. Ann	5	8		1	1	6	13	35	1	7	1	1			21	58	79
Trelawny		2	2	2		1	2	19		2					4	26	30
St. James	3	9		4	1	4	5	26	1	2					10	45	55
Hanover	3	4		2	2		4	9		1	1				10	16	26
Westmoreland	6	9		3	1	3	5	21		2	1			1	13	39	52
St. Elizabeth	4	7	2		1	7	9	18	2	1	1	2			19	35	54
Manchester	6	7	1	1	3	4	6	17	1	7	1				18	36	54
Clarendon	4	4	1	3	1	8	12	28	5	12		1			23	56	79
St. Catherine	1	1	1	3	2	4	9	37	3	6	1	2			17	53	70
Total	38	66	7	27	15	52	78	281	19	58	9	8		2	166	494	660
Grand Total	104		34		67		359		77		17		2		660		

TABLE 2-18

**Teachers In All Age Schools Grades 7-9 By Qualification, Sex and Parish
2008/2009**

Parish	Trained University Graduate		Untrained University Graduate		Trained College Graduate		* Untrained Tertiary Level Graduate		Trained Instructor		Untrained Secondary School Graduate		Total		Grand Total
	M	F	M	F	M	F	M	F	M	F	M	F	M	F	
Kingston	1	8			1	6					1	1	3	15	18
St. Andrew	2	21	1	1	7	18	1				4	6	15	46	61
St. Thomas		6				11						3		20	20
Portland	1	19	2	6	4	18		1				2	7	46	53
St. Mary		1			6	2							6	3	9
St. Ann	7	25		3	13	26					1	4	21	58	79
Trelawny	1	7		1	2	17			1			1	4	26	30
St. James	3	21		1	6	22	1	1					10	45	55
Hanover	3	7			6	8					1	1	10	16	26
Westmoreland	8	16		2	4	20					1	1	13	39	52
St. Elizabeth	11	11	1	1	5	22	1				1	1	19	35	54
Manchester	6	13		4	11	16		3			1		18	36	54
Clarendon	6	17		2	12	27	4	2			1	8	23	56	79
St. Catherine	3	23	1	1	10	24	1	2			2	3	17	53	70
Total	52	195	5	22	87	237	8	9	1		13	31	166	494	660
Grand Total	247		27		324		17		1		44		660		

* Certificate/Diploma

TABLE 2-19

Teachers In Primary & Junior High Schools Grades 1-6 By Post, Sex and Parish

2008/2009

Parish	Principal		Vice Principal		Senior Teacher		Trained Teacher		Pre-Trained Teacher		Specialist		Master Teacher		Total		Grand Total
	M	F	M	F	M	F	M	F	M	F	M	F	M	F	M	F	
Kingston				2	1	12	4	51		6					5	71	76
St. Andrew	2	3	1	7	1	46	12	193	3	33		1			19	283	302
St. Thomas		1				5	2	34		2					2	42	44
Portland	1	1				2	1	32		7		1			2	43	45
St. Mary		3	1	1		11	5	64		5					6	84	90
St. Ann		1		3	2	17		54		7					2	82	84
Trelawny				1		4	1	15		1					1	21	22
St. James			1	4	1	30	3	84		9					5	127	132
Hanover		1		1		10	2	39						1	2	52	54
Westmoreland		1				8	4	30		4					4	43	47
St. Elizabeth				3	1	13	1	38		6		1			2	61	63
Manchester	1			4		25	9	104	1	5					11	138	149
Clarendon	3	1	1	5		24	7	120	3	9		1			14	160	174
St. Catherine	2			5		17	5	83		7		4			7	116	123
Total	9	12	4	36	6	224	56	941	7	101		8		1	82	1323	1405
Grand Total		21		40		230		997		108		8		1		1405	

TABLE 2-20

Teachers In Primary & Junior High Schools Grades 1-6 By Qualification, Sex and Parish

2008/2009

Parish	Trained University Graduate		Untrained University Graduate		Trained College Graduate		* Untrained Tertiary Level Graduate		Trained Instructor		Untrained Secondary School Graduate		Total		Grand Total
	M	F	M	F	M	F	M	F	M	F	M	F	M	F	
Kingston	1	25		1	4	40						5	5	71	76
St. Andrew	3	87		2	12	162	1	4	1			2	19	283	302
St. Thomas		12			2	28						2	2	42	44
Portland	1	8			1	26		4		1		4	2	43	45
St. Mary	2	13			4	66						5	6	84	90
St. Ann	2	27		2		48						5	2	82	84
Trelawny		7			1	13						1	1	21	22
St. James	1	53		2	4	65						7	5	127	132
Hanover		18			2	34							2	52	54
Westmoreland	1	16			3	23		2				2	4	43	47
St. Elizabeth		24		1	2	31		1				4	2	61	63
Manchester	6	67		2	4	66						1	11	138	149
Clarendon	4	43		4	7	107		4				3	14	160	174
St. Catherine	3	29		2	4	80						5	7	116	123
Total	24	429		16	50	789	1	15	1	1		6	82	1323	1405
Grand Total	453		16		839		16		2		79		1405		

* Certificate/Diploma

TABLE 2-21

Teachers In Primary & Junior High Schools Grades 7-11 By Post, Sex and Parish

2008/2009

Parish	Principal		Vice Principal		Senior Teacher		Trained Teacher		Pre-Trained Teacher		Specialist		Master Teacher		Total		Grand Total
	M	F	M	F	M	F	M	F	M	F	M	F	M	F	M	F	
Kingston	2		2	1	4	6	13	29	2	6	4	5			27	47	74
St. Andrew	4	6	4	8	5	41	39	141	7	24	8	10			67	230	297
St. Thomas		2	1	1	3	4	2	13	4	6	1	2			11	28	39
Portland		4		1	1	4	9	20	1	3					11	32	43
St. Mary	1	3	1	4	1	14	15	22	8	9	1	2			27	54	81
St. Ann	1	4	1	3	2	10	10	29	5	4	2	2			21	52	73
Trelawny	1	1		1	1	3	3	11	1	1	1				7	17	24
St. James	4	3	2	5	4	15	9	41		2	1	2		1	20	69	89
Hanover	1	1		3	1	5		13		2					2	24	26
Westmoreland	1	2		1	6	5	6	23	2	2	1				16	33	49
St. Elizabeth	3	2		5	3	7	12	30	3	4		1			21	49	70
Manchester	3	2	2	3	5	18	17	67	4	3	2				33	93	126
Clarendon	6	2	2	4	6	20	30	98	8	8	2	3			54	135	189
St. Catherine	3	3	1	4	3	18	25	93	5	13	4	9			41	140	181
Total	30	35	16	44	45	170	190	630	50	87	27	36		1	358	1003	1361
Grand Total	65		60		215		820		137		63		1		1361		

TABLE 2-22

Teachers In Primary & Junior High Schools Grades 7-11 By Qualification, Sex and Parish

2008/2009

Parish	Trained University Graduate		Untrained University Graduate		Trained College Graduate		* Untrained Tertiary Level Graduate		Trained Instructor		Untrained Secondary School Graduate		Total		Grand Total
	M	F	M	F	M	F	M	F	M	F	M	F	M	F	
Kingston	8	20	1		16	21	1				1	6	27	47	74
St. Andrew	20	97		8	36	103	4	8	1	1	6	13	67	230	297
St. Thomas	2	9	1		4	12	2	2		1	2	4	11	28	39
Portland	4	11	1	3	6	16						2	11	32	43
St. Mary	4	23		2	14	21	4	3			5	5	27	54	81
St. Ann	5	23	2	3	10	24	1	1			3	1	21	52	73
Trelawny	2	3	1		4	13						1	7	17	24
St. James	7	38			13	28		1				2	20	69	89
Hanover	2	10		3		11							2	24	26
Westmoreland	5	18			9	13	1				1	2	16	33	49
St. Elizabeth	3	19			14	25		1			4	4	21	49	70
Manchester	7	42	1	1	20	45			2	2	3	3	33	93	126
Clarendon	15	59	2	5	29	66	5	3	2		1	2	54	135	189
St. Catherine	8	54	2	4	24	72	4	3	1	1	2	6	41	140	181
Total	92	426	11	29	199	470	22	22	6	5	28	51	358	1003	1361
Grand Total	518		40		669		44		11		79		1361		

* Certificate/Diploma

TABLE 2-23

Teachers In Secondary High Schools By Post, Sex and Parish

2008/2009

Parish	Principal		Vice Principal		Senior Teacher		Trained Teacher		Pre-Trained Teacher		Specialist		Master Teacher		Total		Grand Total
	M	F	M	F	M	F	M	F	M	F	M	F	M	F	M	F	
Kingston	6	7	6	17	39	120	129	329	87	153	36	8		1	303	635	938
St. Andrew	10	17	14	30	92	289	314	822	110	249	46	31	1	3	587	1441	2028
St. Thomas	3	2	1	5	19	45	53	121	25	36	13	5		1	114	215	329
Portland	3	2	3	8	14	52	52	128	29	38	11	3			112	231	343
St. Mary	4	5	3	11	21	55	57	171	24	61	17	11			126	314	440
St. Ann	3	4	1	10	29	73	69	200	29	44	7	6			138	337	475
Trelawny	3	4	4	7	18	39	55	142	21	57	6	5			107	254	361
St. James	6	5	1	12	32	77	102	315	36	82	22	9	1	1	200	501	701
Hanover		5	2	4	14	22	40	122	27	62	4	3			87	218	305
Westmoreland	1	4	4	8	19	58	69	181	20	62	12	2			125	315	440
St. Elizabeth	4	5	3	10	30	70	76	232	53	53	18	8	1	1	185	379	564
Manchester	7	3	3	14	32	91	70	230	28	55	22	4			162	397	559
Clarendon	11	6	9	19	63	147	188	476	50	87	33	14			354	749	1103
St. Catherine	10	11	10	26	83	237	283	744	112	174	45	43			543	1235	1778
Total	71	80	64	181	505	1375	1557	4213	651	1213	292	152	3	7	3143	7221	10364
Grand Total	151		245		1880		5770		1864		444		10		10364		

TABLE 2-24

**Teachers In Secondary High Schools By Qualification, Sex and Parish
2008/2009**

Parish	Trained University Graduate		Untrained University Graduate		Trained College Graduate		* Untrained Tertiary Level Graduate		Trained Instructor		Untrained Secondary School Graduate		Total		Grand Total
	M	F	M	F	M	F	M	F	M	F	M	F	M	F	
Kingston	78	287	49	118	111	176	16	19	17	6	32	29	303	635	938
St. Andrew	194	764	71	192	247	395	32	27	12	11	31	52	587	1441	2028
St. Thomas	29	94	13	20	50	78	14	7	1	1	7	15	114	215	329
Portland	29	90	11	23	42	95	18	11	4	4	8	8	112	231	343
St. Mary	31	116	7	27	56	126	14	9	4	3	14	33	126	314	440
St. Ann	23	137	18	18	65	147	13	10	9	1	10	24	138	337	475
Trelawny	24	92	5	16	52	99	7	12	3	2	16	33	107	254	361
St. James	43	207	17	48	105	202	19	18	7	4	9	22	200	501	701
Hanover	17	57	8	21	35	96	17	20	3	1	7	23	87	218	305
Westmoreland	33	142	5	17	61	108	6	9	9	2	11	37	125	315	440
St. Elizabeth	27	144	19	18	82	172	23	14	8	4	26	27	185	379	564
Manchester	36	167	11	30	76	170	24	17	6		9	13	162	397	559
Clarendon	97	331	17	50	176	321	28	12	16	1	20	34	354	749	1103
St. Catherine	119	527	37	91	284	517	47	34	9	3	47	63	543	1235	1778
Total	780	3155	288	689	1442	2702	278	219	108	43	247	413	3143	7221	10364
Grand Total	3935		977		4144		497		151		660		10364		

* Certificate/Diploma

TABLE 2-25

Teachers In Technical High Schools By Post, Sex and Parish

2008/2009

Parish	Principal		Vice Principal		Senior Teacher		Trained Teacher		Pre-Trained Teacher		Specialist		Master Teacher		Total		Grand Total
	M	F	M	F	M	F	M	F	M	F	M	F	M	F	M	F	
Kingston		2	2		4	5	35	63	4	3	4	1			49	74	123
St. Andrew		1			7	9	19	26	16	10					42	46	88
St. Thomas	1			2	5	12	10	22	5	12	4	2			25	50	75
St. Mary	1				1	2	7	31	3	8	4				16	41	57
St. Ann	1			2	3	18	16	58	14	20	4	1			38	99	137
St. James	1		1	1	9	9	21	35	4	9	1	1	1		38	55	93
Hanover		1		1	6	9	7	22	4	10	3	3			20	46	66
Westmoreland		1		1	2	8	12	22	2	8	6	4			22	44	66
St. Elizabeth	1	1	1	1	7	17	12	39	9	6	3				33	64	97
Manchester	1		2	1	8	7	10	21	6	8	8	1			35	38	73
Clarendon		1	1		2	10	16	48	6	8	2	3			27	70	97
St. Catherine	2		1	4	10	20	28	86	22	15	6	4			69	129	198
Total	8	7	8	13	64	126	193	473	95	117	45	20	1		414	756	1170
Grand Total	15		21		190		666		212		65		1		1170		

TABLE 2-26

**Teachers In Technical High Schools By Qualification, Sex and Parish
2008/2009**

Parish	Trained University Graduate		Untrained University Graduate		Trained College Graduate		* Untrained Tertiary Level Graduate		Trained Instructor		Untrained Secondary School Graduate		Total		Grand Total
	M	F	M	F	M	F	M	F	M	F	M	F	M	F	
Kingston	13	31	2	1	25	35	1		6	5	2	2	49	74	123
St. Andrew	10	17	3	5	12	19	12	2	2		3	3	42	46	88
St. Thomas	7	23	1	3	8	13	2	3	2	1	5	7	25	50	75
St. Mary	1	9	1	5	7	23	4	1	3			3	16	41	57
St. Ann	7	24	2	6	13	49	6	6	2	3	8	11	38	99	137
St. James	16	16	4	10	16	28	1		1			1	38	55	93
Hanover	2	11		3	13	25	2	1			3	6	20	46	66
Westmoreland	10	15	1	3	9	21	1	3			1	2	22	44	66
St. Elizabeth	6	40	8	4	12	17	2	2	4		1	1	33	64	97
Manchester	8	16	4	5	12	13	5	1	4		2	3	35	38	73
Clarendon	8	35	3	9	8	24	4	1	3	1	1		27	70	97
St. Catherine	20	59	12	8	21	51	4	1	3	2	9	8	69	129	198
Total	108	296	41	62	156	318	44	21	30	12	35	47	414	756	1170
Grand Total	404		103		474		65		42		82		1170		

* Certificate/Diploma

TABLE 2-27

Teachers In Agricultural High By Post, Sex and Parish

2008/2009

Parish	Principal		Vice Principal		Senior Teacher		Trained Teacher		Pre-Trained Teacher		Specialist		Master Teacher		Total		Grand Total
	M	F	M	F	M	F	M	F	M	F	M	F	M	F	M	F	
Hanover	1		1		1	1	1	3		3	2				6	7	13
St. Elizabeth	1			1	1	2	1	6	3		4	2			10	11	21
Total	2		1	1	2	3	2	9	3	3	6	2			16	18	34
Grand Total	2		2		5		11		6		8				34		

TABLE 2-28

**Teachers In Agricultural High By Qualification, Sex and Parish
2008/2009**

Parish	Trained University Graduate		Untrained University Graduate		Trained College Graduate		* Untrained Tertiary Level Graduate		Trained Instructor		Untrained Secondary School Graduate		Total		Grand Total
	M	F	M	F	M	F	M	F	M	F	M	F	M	F	
Hanover	3	3			3	1		3					6	7	13
St. Elizabeth		6	3		4	4		3				1	10	11	21
Total	3	9	3		7	5		3	3			1	16	18	34
Grand Total		12		3		12		6				1		34	

* Certificate/Diploma

TABLE 2 - 29

**PERCENTAGE DISTRIBUTION OF TEACHERS IN INFANT,
PRIMARY AND SECONDARY SCHOOLS
BY QUALIFICATION
2004 TO 2008**

Year	Male	Female	Total	Trained University Graduate	Untrained University Graduate	Trained College Graduate	Untrained Tertiary Level Graduate	Trained Instructor	Untrained Secondary School Graduate
2004	22.0	78.0	100.0 (23,372)	27.2	6.0	55.9	4.9	1.5	4.5
2005	21.6	78.4	100.0 (23,862)	29.1	4.8	55.8	3.3	1.0	5.9
2006	21.5	78.5	100.0 (24,276)	29.6	4.8	55.5	3.3	1.0	5.8
2007	21.3	78.7	100.0 (24,644)	31.8	5.1	53.5	3.1	1.0	5.5
2008	21.0	79.0	100.0 (25,013)	34.2	5.3	50.2	3.0	0.9	6.4

TABLE 2 - 30

**PERCENTAGE DISTRIBUTION OF TRAINED TEACHERS
AT THE EARLY CHILDHOOD, PRIMARY AND SECONDARY LEVELS
2004 TO 2008**

Year	Early childhood				Primary				Secondary			
	Number of Teachers			Percentage Trained	Number of Teachers			Percentage Trained	Number of Teachers			Percentage Trained
	M	F	T		M	F	T		M	F	T	
2004	13	635	648	89.2	1,134	9,154	10,288	89.6	3,989	8,447	12,436	80.3
2005	11	584	595	88.9	1,163	9,448	10,611	89.8	3,974	8,682	12,656	82.4
2006	13	589	602	88.9	1,136	9,526	10,662	90.4	4,076	8,936	13,012	82.4
2007	14	616	630	92.2	1,156	9,585	10,741	91.3	4,089	9,184	13,273	81.9
2008	23	667	690	90.6	1,135	9,599	10,734	91.0	4,097	9,492	13,589	80.5

TABLE 2 - 31

**TEACHER - PUPIL RATIO IN INFANT, PRIMARY & SECONDARY LEVEL SCHOOLS
2008/2009**

SCHOOL TYPE	ENROLMENT	NUMBER OF TEACHERS			TEACHER:PUPIL RATIO
		TRAINED TEACHER	UNTRAINED TEACHER	TOTAL	
INFANT	7,909	342	24	366	1:23
PRIMARY (Inclusive of Infant Department)	203,495	7,406	773	8,179	1:27
ALL AGE (Inclusive of Infant Department)	45,115	1,888	212	2,100	1:23
JUNIOR HIGH/PRIMARY & JUNIOR HIGH (Inclusive of Infant Department)	59,023	2,522	278	2,800	1:22
SECONDARY HIGH	199,545	8,230	2,134	10,364	1:20
TECHNICAL HIGH	21,065	920	250	1,170	1:19
AGRICULTURAL HIGH	347	24	10	34	1:07
TOTAL	536,499	21,332	3,681	25,013	1:22

NB. Number of teachers include administrators, guidance counsellors and teachers on leave

TABLE 2-32

**ACADEMIC STAFF IN TERTIARY INSTITUTIONS
BY QUALIFICATION, SEX AND INSTITUTION
2008/2009**

INSTITUTION	DEGREE								DIPLOMA/CERTIFICATE		TOTAL		GRAND TOTAL
	PHD		MASTERS		BACHELOR		ASSOCIATE						
	M	F	M	F	M	F	M	F	M	F	M	F	
Teachers Colleges													
Bethlehem	1	3	2	25	11	14	-	-	2	1	16	43	59
Church	1	2	4	22	4	9	-	-	1	-	10	33	43
Mico	1	5	5	47	21	34	-	-	-	-	27	86	113
Sam Sharpe	1	1	5	29	2	11	-	-	-	1	8	42	50
Shortwood	-	-	5	39	8	25	-	-	1	-	14	64	78
St.Josephs	-	1	3	19	2	13	-	-	-	1	5	34	39
Community Colleges													
Brown'sTown	-	-	4	10	18	34	-	-	2	5	24	49	73
Exed	-	3	11	20	31	32	3	-	2	2	47	57	104
Knox	1	1	8	43	23	22	-	-	5	3	37	69	106
Montego Bay	-	1	9	25	21	26	1	-	2	-	33	52	85
Portmore	-	-	6	22	19	21	1	-	-	3	26	46	72
Other													
Moneague	-	-	6	21	21	21	-	1	2	-	29	43	72
G. C. Foster College	-	-	3	9	11	5	-	-	1	-	15	14	29
Edna Manley College	2	4	15	24	16	20	1	-	27	12	61	60	121
CASE	2	4	18	18	15	16	-	-	1	-	36	38	74
Utech *	24	36	135	153	18	19	-	-	8	1	185	209	394
UWI	-	-	-	-	-	-	-	-	-	-	-	-	-
TOTAL	33	61	239	526	241	322	6	1	54	29	573	939	1512
GRAND TOTAL	94		765		563		7		83		1512		

* Data not submitted

TABLE 2 - 33

**ACADEMIC STAFF IN COMMUNITY COLLEGES
BY POST, SEX AND INSTITUTION
2008/2009**

Institution	PRINCIPAL		VICE PRINCIPAL		DIRECTOR		HEAD OF DEPARTMENT		PRINCIPAL LECTURER		SENIOR LECTURER		LECTURER		ASSISTANT LECTURER		INSTRUCTOR		TOTAL		GRAND TOTAL
	M	F	M	F	M	F	M	F	M	F	M	F	M	F	M	F	M	F	M	F	
Brown's Town	1	-	-	1			-	-	-	1	4	6	4	9	15	28	-	4	24	49	73
Exed	-	1	1	2			-	1	3	6	5	11	8	21	29	16	-	-	46	58	104
Knox	1	-	-	1			-	-	2	8	6	12	14	28	14	16	-	4	37	69	106
Montego Bay	-	1	-	1			3	5	-	-	3	8	2	10	25	26	-	1	33	52	85
Portmore	-	-	1	-	1	-	-	5	-	3	3	6	11	22	10	8	-	2	26	46	72
Total	2	2	2	5	1		3	11	5	18	21	43	39	90	93	94	-	11	166	274	440
Grand Total	4		7		1		14		23		64		129		187		11		440		

TABLE 2 - 34

**ACADEMIC STAFF IN COMMUNITY COLLEGES
BY QUALIFICATION, SEX AND INSTITUTION
2008/2009**

Institution	DEGREE								DIPLOMA/CERTIFICATE		TOTAL		GRAND TOTAL
	PH.D		MASTERS		BACHELOR		ASSOCIATE						
	M	F	M	F	M	F	M	F	M	F	M	F	
Brown's Town	-	-	4	10	18	34	-	-	2	5	24	49	73
Exed	-	3	11	20	31	32	3	-	2	2	47	57	104
Knox	1	1	8	43	23	22	-	-	5	3	37	69	106
Montego Bay	-	1	9	25	21	26	1	-	2	-	33	52	85
Portmore	-	-	6	22	19	21	1	-	-	3	26	46	72
Total	1	5	38	120	112	135	5	-	11	13	167	273	440
Grand Total	6		158		247		3		24		440		

TABLE 2 - 35

**ACADEMIC STAFF AT MONEAGUE COLLEGE
BY POST AND SEX
2008/2009**

INSTITUTION	PRINCIPAL		VICE PRINCIPAL		PRINCIPAL LECTURER		SENIOR LECTURER		LECTURER		ASSISTANT LECTURER		TOTAL	GRAND TOTAL	
	M	F	M	F	M	F	M	F	M	F	M	F			
MONEAGUE COLLEGE	1	-	-	3	1	5	7	8	14	18	6	9	29	43	72
TOTAL	1		-	3	1	5	7	8	14	18	6	9	29	43	
GRAND TOTAL	1		3		6		15		32		15		72		

TABLE 2 - 36

**ACADEMIC STAFF AT MONEAGUE COLLEGE
BY QUALIFICATION AND SEX
2008/2009**

INSTITUTION	DEGREE								DIPLOMA/CERTIFICATE	TOTAL	GRAND TOTAL		
	PHD		MASTERS		BACHELORS		ASSOCIATE						
	M	F	M	F	M	F	M	F				M	F
MONEAGUE COLLEGE	-	-	6	21	21	21	-	1	2	-	29	43	72
TOTAL	-	-	6	21	21	21	-	-	2	0	29	43	
GRAND TOTAL	-		27		42		-		2		72		

TABLE 2 - 37

**ACADEMIC STAFF IN TEACHERS' COLLEGES
BY POST, SEX AND INSTITUTION
2008/2009**

INSTITUTION	PRINCIPAL		VICE PRINCIPAL		DEAN		HEAD OF DEPARTMENT		PRINCIPAL LECTURER		SENIOR LECTURER		LECTURER		ASSISTANT LECTURER		TOTAL		GRAND TOTAL
	M	F	M	F	M	F	M	F	M	F	M	F	M	F	M	F	M	F	
BETHLEHEM	1	-	-	4	-	-	1	1	2	4	4	5	3	23	5	6	16	43	59
CHURCH	-	1	-	1	-	-	-	-	2	6	3	7	5	18	-	-	10	33	43
MICO	1	-	-	-	-	-	3	6	-	1	7	7	16	69	-	3	27	86	113
SAM SHARPE	-	1	1	-	-	-	-	-	1	6	2	10	4	20	-	5	8	42	50
SHORTWOOD	-	1	-	1	-	-	4	9	-	1	2	6	7	40	1	6	14	64	78
ST. JOSEPH'S	-	1	-	1	-	-	-	-	-	4	-	4	5	23	-	1	5	34	39
TOTAL	2	4	1	7	0	-	8	16	5	22	18	39	40	193	6	21	80	302	382
GRAND TOTAL	6		8		1		24		27		57		233		27		382		

TABLE 2 - 38

**ACADEMIC STAFF IN TEACHERS' COLLEGES
BY QUALIFICATION, SEX AND INSTITUTION
2008/2009**

INSTITUTION	DEGREE						DIPLOMA/CERTIFICATE		TOTAL		GRAND TOTAL
	PHD		MASTERS		BACHELOR						
	M	F	M	F	M	F	M	F	M	F	
BETHLEHEM	1	3	2	25	11	14	2	1	16	43	59
CHURCH	1	2	4	22	4	9	1	-	10	33	43
MICO	1	5	5	47	21	34	-	-	27	86	113
SAM SHARPE	1	1	5	29	2	11	-	1	8	42	50
SHORTWOOD	-	-	5	39	8	25	1	-	14	64	78
ST. JOSEPH'S	-	1	3	19	2	13	-	1	5	34	39
TOTAL	4	12	24	181	48	106	4	3	80	302	382
GRAND TOTAL	16		205		154		7		382		

TABLE 2 - 39

**ACADEMIC STAFF AT G.C. FOSTER COLLEGE OF PHYSICAL EDUCATION AND SPORTS
BY POST AND SEX
2008/2009**

INSTITUTION	PRINCIPAL		VICE PRINCIPAL		PRINCIPAL LECTURER		SENIOR LECTURER		LECTURER		ASSISTANT LECTURER		TOTAL		GRAND TOTAL
	M	F	M	F	M	F	M	F	M	F	M	F	M	F	
G.C. FOSTER COLLEGE OF PHYSICAL EDUCATION & SPORTS	-	1	1	1	2	2	-	-	11	9	1	1	15	14	29
TOTAL	0	-	1	-	2	2	-	0	11	9	1	1	15	14	
GRAND TOTAL	0		1		4		0		20		2		29		

TABLE 2 - 40

**ACADEMIC STAFF AT G.C. FOSTER COLLEGE OF PHYSICAL EDUCATION AND SPORTS
BY QUALIFICATION AND SEX
2008/2009**

INSTITUTION	DEGREE						DIPLOMA/CERTIFICATE	TOTAL		GRAND TOTAL	
	PH.D		MASTERS		BACHELORS			M	F		
	M	F	M	F	M	F	M	F			
G.C. FOSTER COLLEGE OF PHYSICAL EDUCATION & SPORTS	-	-	3	9	11	5	1	-	15	14	29
TOTAL	-	-	3	9	11	5	1	-	15	14	
GRAND TOTAL	-		12		16		1		29		

TABLE 2 - 41

**ACADEMIC STAFF AT THE COLLEGE OF AGRICULTURE, SCIENCE AND EDUCATION
BY POST AND SEX
2008/2009**

President		Vice President		Dean		Head of Department		Director		Senior Lecturer		Lecturer		Assistant Lecturer		Instructor		TOTAL		GRAND TOTAL
M	F	M	F	M	F	M	F	M	F	M	F	M	F	M	F	M	F	M	F	
1	-	1	-	1	2	3	1	2	-	3	3	12	26	5	4	8	2	36	38	74

TABLE 2 - 42

**ACADEMIC STAFF AT THE COLLEGE OF AGRICULTURE, SCIENCE AND EDUCATION
BY QUALIFICATION AND SEX
2008/2009**

DEGREE				DIPLOMA/CERTIFICATE	TOTAL	GRAND TOTAL						
PH.D		MASTERS					BACHELORS		ASSOCIATE			
M	F	M	F	M	F	M	F	M	F			
2	4	18	18	15	16	-	-	1	-	36	38	74

TABLE 2 - 43

**ACADEMIC STAFF AT EDNA MANLEY COLLEGE OF THE VISUAL AND PERFORMING ARTS
BY POST AND SEX
2008/2009**

INSTITUTION	PRINCIPAL		VICE PRINCIPAL		DIRECTOR		DEAN		HEAD OF DEPARTMENT		SENIOR LECTURER		LECTURER		ASSISTANT LECTURER		TOTAL	
	M	F			M	F	M	F	M	F	M	F	M	F	M	F	M	F
EDNA MANLEY COLLEGE OF THE VISUAL & PREFORMING ARTS	1	-	-	1	2	-	-	4	1	3	7	7	49	43	1	2	61	60
TOTAL	1	-	-	1	2	-	-	4	1	3	7	7	49	43	1	2	61	60
GRAND TOTAL	1		1		2		4		4		14		92		3		121	

TABLE 2 - 44

**ACADEMIC STAFF AT EDNA MANLEY COLLEGE OF THE VISUAL AND PERFORMING ARTS
BY QUALIFICATION AND SEX
2008/2009**

INSTITUTION	DEGREE								DIPLOMA/CERTIFICATE	TOTAL		GRAND TOTAL	
	PH.D		MASTERS		BACHELORS		ASSOCIATE			M	F		
	M	F	M	F	M	F	M	F	M	F			
EDNA MANLEY COLLEGE OF THE VISUAL & PERFORMING ARTS	2	4	15	24	16	20	1	-	27	12	61	60	121
TOTAL	2	4	15	24	16	20	1	-	27	12	61	60	
GRAND TOTAL	6		39		36		1		27	12	121		

TABLE 2 - 45

**FULL TIME ACADEMIC STAFF AT THE UNIVERSITY OF TECHNOLOGY
BY POST, DEPARTMENT/SCHOOL AND SEX
2007/2008**

FACUTLY	DEAN		VICE -DEAN		ASSOCIATE PROFESSOR		HEAD OF DEPARTMENT		PRINCIPAL LECTURER		SENIOR LECTURER		LECTURER		ASSISTANT LECTURER		GRAND TOTAL		
	M	F	M	F	M	F	M	F	M	F	M	F	M	F	M	F	M	F	T
BUILT ENVIRONMENT	0	1	0	0	1	0	2	0	1	0	5	1	23	12	3	1	35	15	50
BUSINESS & MANAGEMENT	1	0	0	0	0	0	0	2	0	5	2	3	23	42	1	4	27	56	83
ENGINEERING & COMPUTING	0	1	0	0	1	1	1	0	0	3	5	2	46	19	3	2	56	28	84
HEALTH AND APPLIED SCIENCE	0	1	1	0	1	0	0	0	2	0	4	7	31	41	3	3	42	52	94
EDUCATION & LIBERAL STUDIES	1	0	0	0	0	0	0	2	0	1	4	6	16	46	4	3	25	58	83
TOTAL	2	3	1	0	3	1	3	4	3	9	20	19	139	160	14	13	185	209	394

Source: University of Technology, April 2009

TABLE 2 - 46

**FULL TIME ACADEMIC STAFF AT THE UNIVERSITY OF TECHNOLOGY
BY DEPARTMENT/SCHOOL, QUALIFICATION AND SEX
2007/2008**

FACULTY	CERTIFICATE/ DIPLOMA			POST-GRAD DIPLOMA			BACHELORS			MASTERS			DOCTORATE		
	M	F	T	M	F	T	M	F	T	M	F	T	M	F	T
BUILT ENVIRONMENT															
Caribbean School of Architecture	1	0	1	0	0	0	1	0	1	3	2	5	1	1	2
School of the Built Environment	1	0	1	0	0	0	2	2	4	19	8	27	4	1	5
No specific department in Faculty	0	0	0	0	0	0	0	0	0	0	0	0	0	1	1
BUSINESS & MANAGEMENT															
School of Business Administration	0	0	0	0	0	0	1	3	4	19	22	41	3	8	11
Sch. of Hospitality and Tourism Management	1	0	1	1	0	1	0	4	4	3	19	22	0	0	0
No specific department in Faculty	0	0	0	0	0	0	0	0	0	0	1	1	0	0	0
ENGINEERING & COMPUTING															
Sch. of Computing and Information Technology	0	0	0	0	0	0	1	1	2	19	12	31	2	2	4
School of Engineering	0	0	0	0	0	0	2	1	3	26	7	33	5	3	8
No specific department in Faculty	0	0	0	0	0	0	0	0	0	0	1	1	0	0	0
HEALTH AND APPLIED SCIENCE															
Department of Science and Mathematics	0	0	0	1	0	1	2	0	2	20	14	34	4	4	8
School of Pharmacy	0	0	0	0	0	0	3	5	8	10	21	31	2	6	8
No specific department in Faculty	0	0	0	0	0	0	0	0	0	0	1	1	0	1	1
EDUCATION & LIBERAL STUDIES															
Department of Liberal Studies	0	0	0	0	0	0	1	3	4	7	24	31	1	4	5
Sch. of Technical and Vocational Education	0	0	0	0	1	1	5	0	5	9	20	29	1	3	4
No specific department in Faculty	0	0	0	0	0	0	0	0	0	0	1	1	1	2	3

Table 2 - 47

**Teachers in Special Education Institutions by Qualification, Sex and Parish
(2008/2009)**

PARISH	Trained University Graduate		Untrained University Graduate		Trained College Graduate		Untrained Tertiary Level Graduate		Trained Instructor		Untrained Secondary School Graduate		Total		Grand Total
	M	F	M	F	M	F	M	F	M	F	M	F	M	F	
Kingston	1	8	-	2	1	5	1	4	-	1	1	38	3	58	61
St. Andrew	3	55	1	9	5	69	1	8	-	1	4	31	14	173	187
St. Thomas	-	-	-	-	-	4	-	-	-	-	-	-	-	4	4
St. Ann	-	3	-	-	-	14	-	-	-	-	2	10	2	27	29
Trelawny	-	-	-	-	-	2	-	-	-	-	-	-	-	2	2
St. James	-	2	-	-	-	5	-	1	-	-	1	6	1	14	15
Westmoreland	1	6	1	1	3	17	-	-	1	-	-	1	6	25	31
St. Elizabeth	-	-	-	-	-	-	1	5	-	-	-	-	1	5	6
Manchester	-	9	-	1	2	21	-	-	-	-	1	9	3	40	43
Clarendon	-	1	-	-	-	4	-	-	-	4	-	3	-	12	12
St. Catherine	-	6	1	7	-	16	-	2	1	1	-	-	2	32	34
Total	5	90	3	20	11	157	3	20	2	7	9	98	32	392	424
Grand Total	95		23		168		23		9		107		424		



STUDENT

STATISTICS

Student Statistics

Enrolment

For the academic year 2008/2009 approximately 686, 140¹ students were enrolled in the formal public education system. Approximately 523,546 of these students fell within the age group 3 to 19 years, and were distributed across the first three levels of the public education system - infant, primary and secondary. Table 3-2 presents a breakdown of the distribution by levels.

Of the 135,539² children in the 3-5 age group in the population, an estimated 87.9 percent was enrolled in government owned and community-operated schools, with community operated schools accounting for 88.8 percent, Infant schools and departments 10.3 percent and the primary level the remaining 0.9 percent. In the age group 6-11, 256,326 children were enrolled in public schools, 80.4 percent at the primary level, and 0.4 percent at the secondary level. Approximately 90.4 percent of the population in the age group 12-14 was enrolled in the public school system with 10.2 percent and 89.8 percent enrolled at the primary and secondary levels respectively. Of the 15-16 age group, 84.3 percent was enrolled at the secondary level and a mere 0.003 percent enrolled at the primary level. In the 17-19 age group only 19.3 percent of the population was accounted for at the secondary level.

At the tertiary level there were approximately 39,000³ students registered at the various colleges and universities in the public system. Of this total, seven percent of the students was registered in higher degree programmes, 60 percent were registered in degree programmes and the remaining 33 percent in diploma, certificate and non-tertiary programmes.

¹ Includes 2007/2008 enrolment data for Basic schools and University of Technology

² Mid-year population estimates

³ Includes 2007/2008 enrolment for the University of Technology

FIGURE 3.1

DISTRIBUTION OF ENROLMENT BY LEVEL 2008/2009

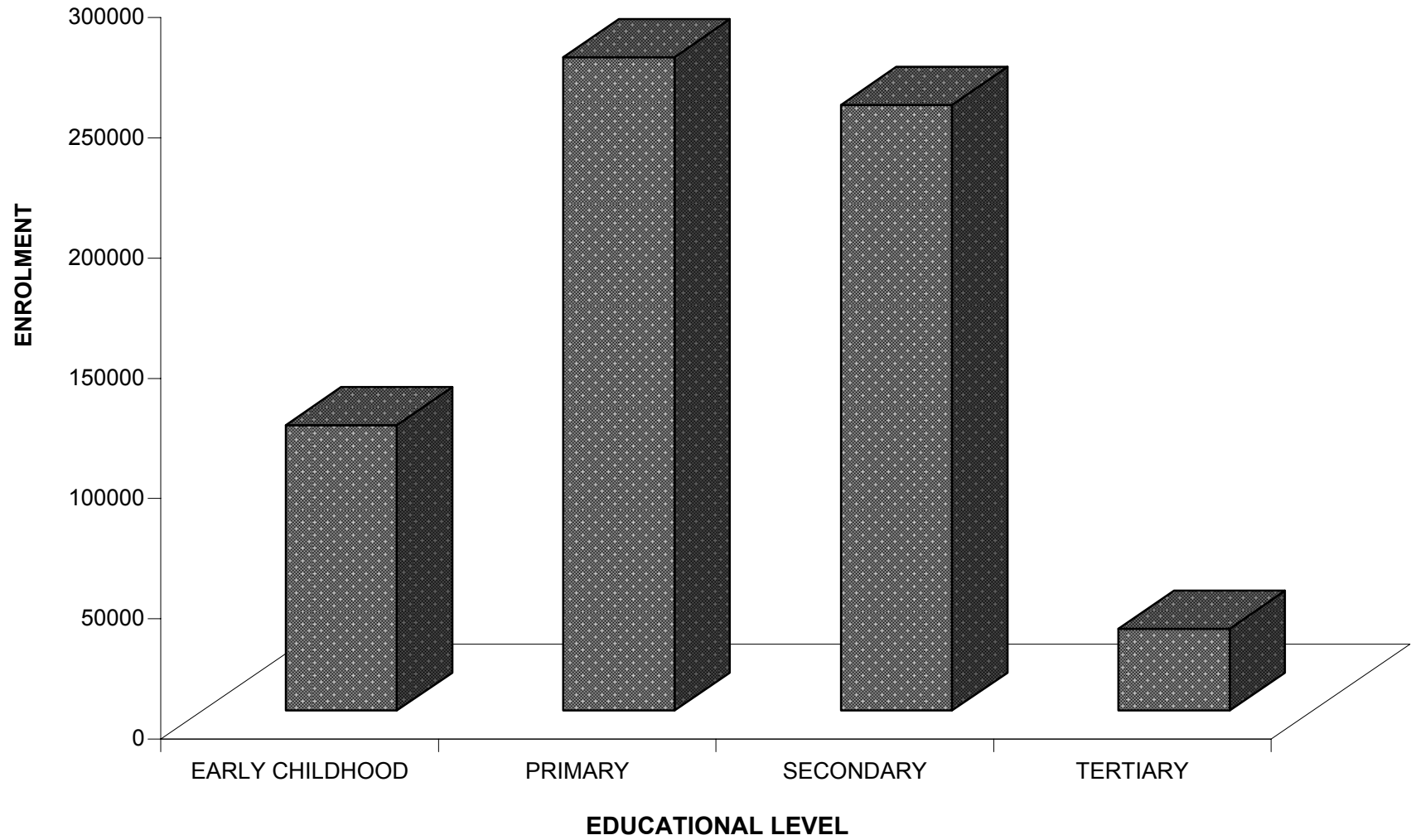

FIGURE 3.1 does not include students in special education

Table 3-1 (a) Percentage Daily Attendance by Region and Level (2006/2007)

Region	Level								
	Infant			Primary			Secondary		
	Male	Female	Total	Male	Female	Total	Male	Female	Total
Kingston	81.7	84.4	83.1	86.9	89.3	88.1	83.6	87.9	85.9
Port Antonio	72.3	74.0	73.0	83.1	85.8	84.4	81.3	87.9	84.7
Brown's Town	73.6	73.7	73.7	81.9	84.1	83.0	81.2	87.1	84.2
Montego Bay	77.0	77.3	77.1	82.3	85.0	83.6	73.2	79.9	76.7
Mandeville	81.3	81.3	81.3	84.3	87.1	85.7	77.9	83.3	80.4
Old Harbour	81.2	83.6	82.4	83.7	86.3	85.0	79.6	83.8	81.7
National	78.4	79.9	79.2	83.6	86.1	84.8	79.3	84.6	82.0

Source: Statistics Unit, Ministry of Education, 2009

Table 3-1 (b) Percentage Daily Attendance by Region and Level (2007/2008)

Region	Level								
	Infant			Primary			Secondary		
	Male	Female	Total	Male	Female	Total	Male	Female	Total
Kingston	77.6	79.8	78.7	83.1	84.9	84.0	80.1	83.7	81.9
Port Antonio	73.6	73.6	73.6	83.8	85.8	84.7	81.6	87.8	84.8
Brown's Town	76.8	76.6	76.7	83.3	85.1	84.2	80.1	85.5	82.8
Montego Bay	77.0	78.3	77.6	83.0	85.6	84.3	80.0	86.1	83.0
Mandeville	81.0	84.1	82.5	82.9	85.5	84.2	82.1	84.9	83.5
Old Harbour	73.2	71.0	72.1	79.4	81.3	80.3	79.9	83.5	81.7
National	76.4	76.9	76.6	82.0	84.1	83.1	80.4	84.7	82.6

Source: Statistics Unit, Ministry of Education, 2009

TABLE 3-2

**Enrolment in Primary, All Age and Secondary Schools
By Age, Sex and Grade
2008/2009**

Age	Sex	Total 1 - 6	Total 7 - 13	Total 1 - 13	Grade 1	Grade 2	Grade 3	Grade 4	Grade 5	Grade 6	Grade 7	Grade 8	Grade 9	Grade 10	Grade 11	Grade 12	Grade 13
3	M																
	F																
4	M	5		5	5												
	F	4		4	4												
5	M	572		572	572												
	F	543		543	538	3	2										
6	M	18,362		18,362	17,677	673	12										
	F	17,796		17,796	17,123	647	26										
7	M	21,343		21,343	3,351	17,472	519	1									
	F	20,817		20,817	2,392	17,696	719	10									
8	M	23,047		23,047	185	3,875	18,464	521	2								
	F	22,214		22,214	85	2,746	18,793	564	26								
9	M	22,534		22,534	15	231	3,923	17,605	757	3							
	F	21,593		21,593	11	107	2,667	18,033	766	9							
10	M	21,589	6	21,595	4	18	263	3,947	16,755	602	6						
	F	21,586	12	21,598	4	8	135	2,813	17,760	866	12						
11	M	22,716	456	23,172		1	26	446	5,163	17,080	449	7					
	F	21,569	686	22,255		2	10	189	3,402	17,966	670	16					
12	M	8,508	15,903	24,411		2	5	48	447	8,006	15,216	667	20				
	F	6,635	16,907	23,542		1	3	24	172	6,435	16,107	773	26	1			
13	M	162	26,398	26,560				6	19	137	8,892	16,586	906	14			
	F	102	25,276	25,378				1	7	94	6,879	17,417	905	75			
14	M	17	26,125	26,142					3	14	354	8,270	16,939	541	21		
	F	5	25,021	25,026						5	181	6,570	17,550	701	19		
15	M	3	23,406	23,409					1	2	9	395	9,635	12,823	536	8	
	F		23,174	23,174							1	170	8,056	14,376	562	9	
16	M		19,828	19,828								11	1,487	7,809	10,284	213	24
	F		20,301	20,301							1	5	996	6,393	12,594	305	7
17	M		10,757	10,757								1	129	1,601	7,644	1,192	190
	F		9,639	9,639							1		65	1,140	6,270	1,899	264
18	M		3,513	3,513									9	130	1,839	632	903
	F		3,290	3,290									1	121	1,178	536	1,454
19	M		646	646									1		199	138	308
	F		480	480										5	102	58	315
Total	M	138,858	127,038	265,896	21,809	22,272	23,212	22,574	23,147	25,844	24,926	25,937	29,126	22,918	20,523	2,183	1,425
	F	132,864	124,786	257,650	20,157	21,210	22,355	21,634	22,133	25,375	23,852	24,951	27,599	22,812	20,725	2,807	2,040
Grand Total		271,722	251,824	523,546	41,966	43,482	45,567	44,208	45,280	51,219	48,778	50,888	56,725	45,730	41,248	4,990	3,465

FIGURE 3.2

DISTRIBUTION OF ENROLMENT IN PUBLIC INSTITUTIONS BY PARISH 2008/2009

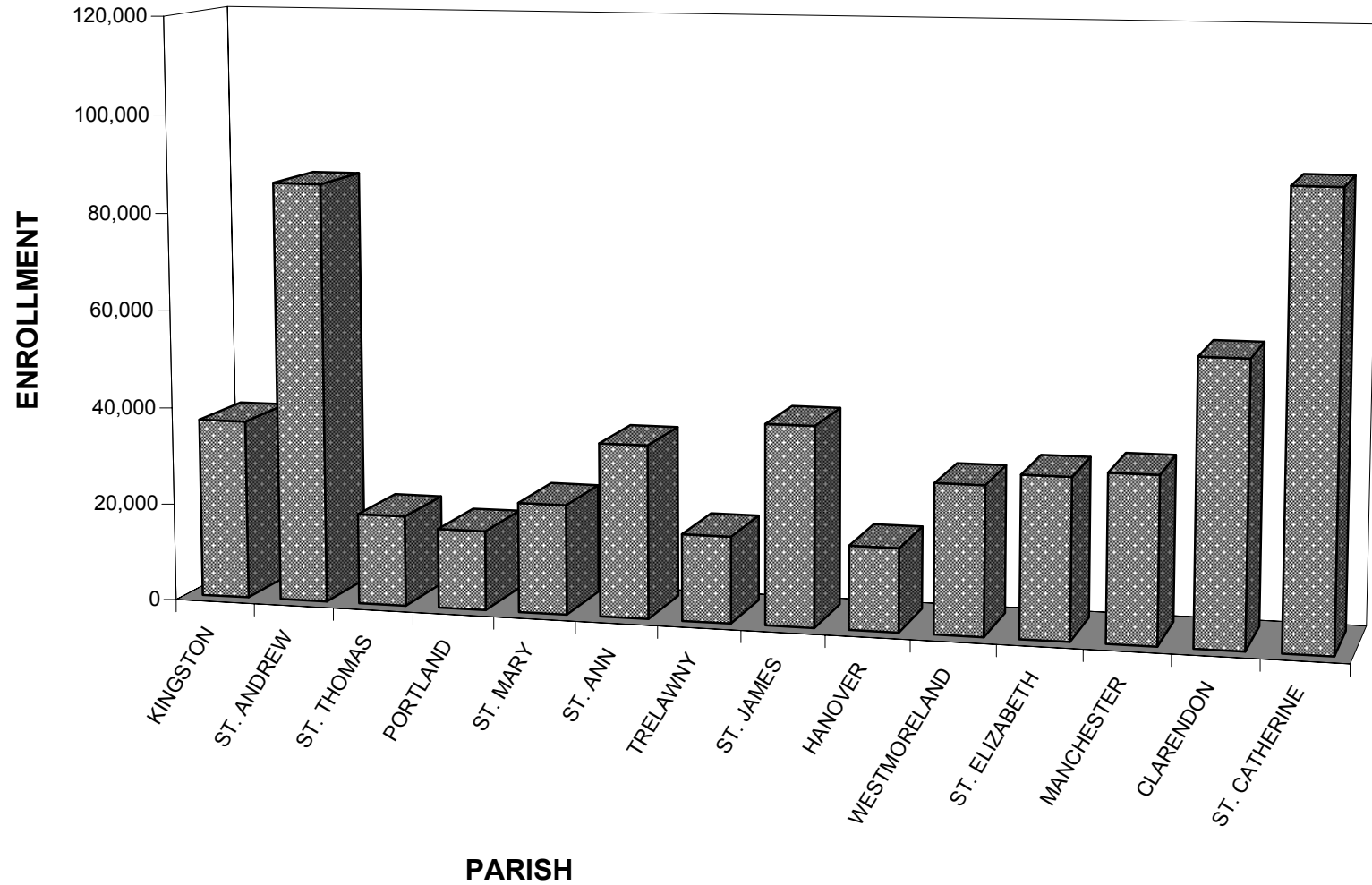

FIGURE 3.2 does not include students in special education.

TABLE 3-3

**Enrolment in Primary and Secondary Level Schools
By Region, Grade and Sex
2008/2009**

REGION	Sex	Total 1 - 6	Total 7 - 9	Total 10 - 11	Total 12 - 13	Grand Total	Grade 1	Grade 2	Grade 3	Grade 4	Grade 5	Grade 6	Grade 7	Grade 8	Grade 9	Grade 10	Grade 11	Grade 12	Grade 13
Kingston	M	30,243	20,100	10,992	1,766	63,101	4,646	4,820	4,904	4,929	5,189	5,755	6,311	6,533	7,256	5,754	5,238	1,032	734
	F	29,677	19,327	10,906	2,185	62,095	4,482	4,736	4,891	4,864	4,991	5,713	6,076	6,332	6,919	5,766	5,140	1,215	970
Port Antonio	M	10,545	6,500	3,497	275	20,817	1,683	1,708	1,717	1,725	1,818	1,894	2,046	2,102	2,352	1,784	1,713	201	74
	F	9,842	6,491	3,676	377	20,386	1,480	1,572	1,678	1,590	1,686	1,836	2,035	2,171	2,285	1,907	1,769	235	142
Brown's Town	M	17,649	9,169	4,695	38	31,551	2,768	2,868	2,998	2,903	2,821	3,291	2,761	3,047	3,361	2,501	2,194	24	14
	F	16,533	8,823	4,898	47	30,301	2,508	2,625	2,715	2,706	2,806	3,173	2,655	2,928	3,240	2,568	2,330	28	19
Montego Bay	M	23,479	12,731	6,947	285	43,442	3,779	3,801	4,021	3,774	3,799	4,305	3,981	4,264	4,486	3,691	3,256	173	112
	F	22,260	12,100	7,128	311	41,799	3,484	3,594	3,838	3,581	3,578	4,185	3,897	3,867	4,336	3,708	3,420	183	128
Mandeville	M	17,115	11,113	6,193	459	34,880	2,711	2,731	2,829	2,723	2,765	3,356	3,314	3,396	4,403	3,320	2,873	287	172
	F	16,354	10,875	6,041	730	34,000	2,419	2,489	2,683	2,707	2,596	3,460	3,313	3,443	4,119	3,133	2,908	432	298
Old Harbour	M	39,827	20,376	11,117	785	72,105	6,222	6,344	6,743	6,520	6,755	7,243	6,513	6,595	7,268	5,868	5,249	466	319
	F	38,198	18,786	10,888	1,197	69,069	5,784	6,194	6,550	6,186	6,476	7,008	5,876	6,210	6,700	5,730	5,158	714	483
Total	M	138,858	79,989	43,441	3,608	265,896	21,809	22,272	23,212	22,574	23,147	25,844	24,926	25,937	29,126	22,918	20,523	2,183	1,425
	F	132,864	76,402	43,537	4,847	257,650	20,157	21,210	22,355	21,634	22,133	25,375	23,852	24,951	27,599	22,812	20,725	2,807	2,040
Grand Total		271,722	156,391	86,978	8,455	523,546	41,966	43,482	45,567	44,208	45,280	51,219	48,778	50,888	56,725	45,730	41,248	4,990	3,465

TABLE 3-5

Enrolment in Infant Schools & Infant Departments of Primary, All Age &

Primary & Junior High Schools by Age and Sex

2008/2009

AGE	INFANT		INFANT DEPT. PRIMARY		INFANT DEPT. ALL AGE		INFANT DEPT. PRIMARY & JUNIOR HIGH		TOTAL		Grand Total
	M	F	M	F	M	F	M	F	M	F	
3	496	487	179	199	22	27	13	14	710	727	1,437
4	1,539	1,496	851	884	79	76	87	88	2,556	2,544	5,100
5	1,776	1,769	975	997	99	82	146	107	2,996	2,955	5,951
6	172	173	173	134	18	12	34	25	397	344	741
7	1		2	1					3	1	4
8			1						1		1
Total	3,984	3,925	2,181	2,215	218	197	280	234	6,663	6,571	13,234
Grand Total		7,909		4,396		415		514		13,234	

TABLE 3-6

Enrolment in Infant Schools & Infant Departments of Primary, All Age &

Primary & Junior High Schools by Parish and Sex

2008/2009

Parish	INFANT		INFANT DEPT. PRIMARY		INFANT DEPT. ALL AGE		INFANT DEPT. PRIMARY & JUNIOR HIGH		TOTAL		Grand Total
	M	F	M	F	M	F	M	F	M	F	
Kingston	606	590	79	200	15	11	64	53	764	854	1,618
St. Andrew			345	320	3	4	146	131	494	455	949
St. Thomas			108	88			6	10	114	98	212
Portland	265	248	59	61					324	309	633
St. Mary	128	112	100	77					228	189	417
St. Ann	354	296	123	105					477	401	878
Trelawny	84	76	220	200					304	276	580
St. James	609	691	158	158	37	47			804	896	1,700
Hanover	174	169			12	8			186	177	363
Westmoreland	253	236	155	150	43	42			451	428	879
St. Elizabeth			61	66	51	39			112	105	217
Manchester	395	373	221	237	9	6	53	22	678	638	1,316
Clarendon	316	256	345	331	36	30	11	18	708	635	1,343
St. Catherine	800	878	207	222	12	10			1,019	1,110	2,129
Total	3,984	3,925	2,181	2,215	218	197	280	234	6,663	6,571	13,234
Grand Total		7,909		4,396		415		514		13,234	

TABLE 3-7

**Enrolment in Primary Schools
By Age, Sex and Grade
2008/2009**

Age	Sex	Grade 1	Grade 2	Grade 3	Grade 4	Grade 5	Grade 6	Total 1 - 6	Grand Total
4	M	1						1	
	F	3						3	4
5	M	351						351	
	F	396	1	2				399	750
6	M	13141	455	11				13607	
	F	13052	483	23				13558	27165
7	M	2472	12907	391	1			15771	
	F	1822	13195	579	8			15604	31375
8	M	133	2861	13612	435	2		17043	
	F	53	2086	13966	462	14		16581	33624
9	M	9	148	2810	12825	498	3	16293	
	F	3	77	2024	13403	559	8	16074	32367
10	M	4	13	176	2809	12217	476	15695	
	F	3	5	92	2062	12993	648	15803	31498
11	M		1	14	296	3603	12355	16269	
	F		1	8	126	2553	13116	15804	32073
12	M		1	2	27	283	5222	5535	
	F			1	16	121	4433	4571	10106
13	M				1	8	54	63	
	F					4	69	73	136
14	M						1	1	
Total	M	16111	16386	17016	16394	16611	18111	100629	
	F	15332	15848	16695	16077	16244	18274	98470	199099
Grand Total		31443	32234	33711	32471	32855	36385	199099	199099

TABLE 3-8

**Enrolment in Primary Schools
By Parish, Grade and Sex
2008/2009**

Parish	Grade 1		Grade 2		Grade 3		Grade 4		Grade 5		Grade 6		Total 1 - 6		Grand Total
	M	F	M	F	M	F	M	F	M	F	M	F	M	F	
Kingston	868	950	917	937	970	1,015	912	950	938	1,016	1,087	1,131	5,692	5,999	11,691
St. Andrew	2,460	2,392	2,539	2,576	2,599	2,598	2,598	2,602	2,656	2,670	2,927	3,022	15,779	15,860	31,639
St. Thomas	731	659	744	675	765	775	720	694	794	691	718	736	4,472	4,230	8,702
Portland	491	436	455	462	458	492	442	442	452	474	540	496	2,838	2,802	5,640
St. Mary	683	580	696	607	685	654	710	656	677	654	813	730	4,264	3,881	8,145
St. Ann	921	851	989	896	1,049	940	985	985	958	970	1,127	1,169	6,029	5,811	11,840
Trelawny	494	494	516	477	594	500	534	422	426	460	508	479	3,072	2,832	5,904
St. James	1,160	1,127	1,117	1,194	1,168	1,210	1,163	1,202	1,109	1,107	1,114	1,190	6,831	7,030	13,861
Hanover	387	389	419	366	418	452	411	405	423	393	444	450	2,502	2,455	4,957
Westmoreland	970	921	969	915	1,057	971	889	882	971	900	1,014	976	5,870	5,565	11,435
St. Elizabeth	1,034	960	1,066	949	1,042	1,011	1,030	1,036	1,037	936	1,298	1,363	6,507	6,255	12,762
Manchester	809	674	728	685	749	728	767	735	733	712	921	920	4,707	4,454	9,161
Clarendon	1,612	1,567	1,604	1,661	1,738	1,712	1,663	1,547	1,756	1,681	1,761	1,764	10,134	9,932	20,066
St. Catherine	3,491	3,332	3,627	3,448	3,724	3,637	3,570	3,519	3,681	3,580	3,839	3,848	21,932	21,364	43,296
Total	16,111	15,332	16,386	15,848	17,016	16,695	16,394	16,077	16,611	16,244	18,111	18,274	100,629	98,470	199,099
Grand Total	31,443		32,234		33,711		32,471		32,855		36,385		199,099		

TABLE 3-9

Enrolment in All-Age Schools Grades 1 - 6

By Age, Sex and Grade

2008/2009

Age	Sex	Grade 1	Grade 2	Grade 3	Grade 4	Grade 5	Grade 6	Total 1 - 6	Grand Total
4	M	4						4	
5	M	131						131	
	F	102	2					104	235
6	M	2237	84					2321	
	F	2015	113	2				2130	4451
7	M	466	2308	52				2826	
	F	275	2163	82	2			2522	5348
8	M	30	457	2393	56			2936	
	F	20	304	2353	59	11		2747	5683
9	M	4	51	555	2319	146		3075	
	F	5	19	329	2139	129		2621	5696
10	M		2	32	525	2171	86	2816	
	F		2	23	413	2292	129	2859	5675
11	M			6	90	739	2260	3095	
	F			2	34	428	2266	2730	5825
12	M		1	1	14	101	1506	1623	
	F		1	1	6	40	1125	1173	2796
13	M				4	9	48	61	
	F					2	17	19	80
14	M					1	11	12	
	F						1	1	13
15	M						1	1	
Total	M	2872	2903	3039	3008	3167	3912	18901	
	F	2417	2604	2792	2653	2902	3538	16906	35807
Grand Total		5289	5507	5831	5661	6069	7450	35807	35807

TABLE 3-10

**Enrolment in All Age Schools Grades 1-6
By Parish, Grade and Sex
2008/2009**

Parish	Grade 1		Grade 2		Grade 3		Grade 4		Grade 5		Grade 6		Total 1 - 6		Grand Total
	M	F	M	F	M	F	M	F	M	F	M	F	M	F	
Kingston	80	51	87	68	88	70	101	67	102	83	127	135	585	474	1,059
St. Andrew	190	189	238	191	228	196	205	214	248	202	240	251	1,349	1,243	2,592
St. Thomas	37	31	24	22	38	26	32	26	52	35	48	32	231	172	403
Portland	122	122	156	120	125	109	142	120	140	121	169	190	854	782	1,636
St. Mary	87	84	92	84	75	87	108	99	93	72	125	83	580	509	1,089
St. Ann	390	322	382	366	416	365	382	361	437	423	506	458	2,513	2,295	4,808
Trelawny	186	169	178	150	176	168	177	163	176	179	178	196	1,071	1,025	2,096
St. James	258	216	274	212	260	241	259	199	299	256	378	328	1,728	1,452	3,180
Hanover	132	108	146	126	125	140	122	122	150	138	160	152	835	786	1,621
Westmoreland	352	309	324	325	376	349	370	289	356	346	471	414	2,249	2,032	4,281
St. Elizabeth	199	172	213	186	235	211	219	207	240	225	347	306	1,453	1,307	2,760
Manchester	199	179	186	174	224	215	206	175	204	193	296	280	1,315	1,216	2,531
Clarendon	373	316	374	364	408	391	443	391	419	380	520	460	2,537	2,302	4,839
St. Catherine	267	149	229	216	265	224	242	220	251	249	347	253	1,601	1,311	2,912
Total	2,872	2,417	2,903	2,604	3,039	2,792	3,008	2,653	3,167	2,902	3,912	3,538	18,901	16,906	35,807
Grand Total	5,289		5,507		5,831		5,661		6,069		7,450		35,807		

TABLE 3-11

Enrolment in All Age Schools Grades 7-9

By Age, Sex and Grade

2008/2009

Age	Sex	Grade 7	Grade 8	Grade 9	Grade 10	Total 7 -10	Grand Total
10	F	2				2	2
11	M	22	1			23	
	F	21				21	44
12	M	868	29	8		905	
	F	387	13			400	1305
13	M	912	1174	64		2150	
	F	331	436	34		801	2951
14	M	81	882	1284		2247	
	F	30	331	694		1055	3302
15	M	4	65	756		825	
	F		23	349		372	1197
16	M		3	73		76	
	F		1	12		13	89
17	M		1	1		2	
	F	1				1	3
Total	M	1887	2155	2186	0	6228	
	F	772	804	1089	0	2665	8893
Grand Total		2659	2959	3275	0	8893	8893

TABLE 3-12

Enrolment in All Age Schools Grades 7-9

By Parish, Grade and Sex

2008/2009

Parish	Grade 7		Grade 8		Grade 9		Grade 10		Total 7 - 10		Grand Total 7 - 9
	M	F	M	F	M	F	M	F	M	F	
Kingston	65	35	88	46	110	50			263	131	394
St. Andrew	199	98	263	123	199	101			661	322	983
St. Thomas	38	15	63	13	41	21			142	49	191
Portland	173	81	119	45	101	78			393	204	597
St. Mary	2	2	5	5	40	32			47	39	86
St. Ann	231	86	358	140	344	205			933	431	1,364
Trelawny	70	26	72	22	146	51			288	99	387
St. James	91	35	167	65	129	67			387	167	554
Hanover	49	22	97	27	54	17			200	66	266
Westmoreland	179	65	209	50	162	89			550	204	754
St. Elizabeth	143	54	119	40	166	87			428	181	609
Manchester	198	72	167	70	210	89			575	231	806
Clarendon	234	131	232	103	267	111			733	345	1,078
St. Catherine	215	50	196	55	217	91			628	196	824
Total	1,887	772	2,155	804	2,186	1,089			6,228	2,665	8,893
Grand Total		2,659		2,959		3,275				8,893	

TABLE 3-13

Enrolment in Primary & Junior High Schools Grades 1-6

By Age, Sex and Grade

2008/2009

Age	Sex	Grade 1	Grade 2	Grade 3	Grade 4	Grade 5	Grade 6	Total 1 - 6	Grand Total
4	F	1						1	1
5	M	90						90	
	F	40						40	130
6	M	2299	134	1				2434	
	F	2056	51	1				2108	4542
7	M	413	2257	76				2746	
	F	295	2338	58				2691	5437
8	M	22	557	2459	30			3068	
	F	12	356	2474	43	1		2886	5954
9	M	2	32	558	2461	113		3166	
	F	3	11	314	2491	78	1	2898	6064
10	M		3	55	613	2367	40	3078	
	F	1	1	20	338	2475	89	2924	6002
11	M			6	60	821	2465	3352	
	F		1		29	421	2584	3035	6387
12	M			2	7	63	1278	1350	
	F			1	2	11	877	891	2241
13	M				1	2	35	38	
	F				1	1	8	10	48
14	M					2	2	4	
	F						4	4	8
15	M					1	1	2	
Total	M	2826	2983	3157	3172	3369	3821	19328	
	F	2408	2758	2868	2904	2987	3563	17488	36816
Grand Total		5234	5741	6025	6076	6356	7384	36816	36816

TABLE 3-14

Enrolment in Primary & Junior High Schools Grades 1-6

By Parish, Grade and Sex

2008/2009

Parish	Grade 1		Grade 2		Grade 3		Grade 4		Grade 5		Grade 6		Total 1 - 6		Grand Total
	M	F	M	F	M	F	M	F	M	F	M	F	M	F	
Kingston	196	157	200	178	122	175	209	173	229	179	245	208	1,201	1,070	2,271
St. Andrew	553	481	562	533	608	550	657	616	720	606	807	713	3,907	3,499	7,406
St. Thomas	80	64	93	88	86	83	72	94	103	84	112	90	546	503	1,049
Portland	53	62	68	61	80	58	80	49	79	73	80	87	440	390	830
St. Mary	191	175	181	201	228	186	234	188	269	237	254	242	1,357	1,229	2,586
St. Ann	232	154	187	172	195	193	205	190	202	186	282	228	1,303	1,123	2,426
Trelawny	52	47	92	69	34	44	52	49	77	68	47	46	354	323	677
St. James	293	194	289	241	379	249	314	253	251	229	397	397	1,923	1,563	3,486
Hanover	141	125	160	122	132	114	126	144	122	98	182	157	863	760	1,623
Westmoreland	86	95	103	93	106	112	120	85	118	111	145	121	678	617	1,295
St. Elizabeth	115	79	113	97	149	128	119	141	121	116	163	164	780	725	1,505
Manchester	355	355	425	398	430	390	382	413	430	414	331	427	2,353	2,397	4,750
Clarendon	279	242	285	283	334	333	351	281	369	342	469	397	2,087	1,878	3,965
St. Catherine	200	178	225	222	274	253	251	228	279	244	307	286	1,536	1,411	2,947
Total	2,826	2,408	2,983	2,758	3,157	2,868	3,172	2,904	3,369	2,987	3,821	3,563	19,328	17,488	36,816
Grand Total	5,234		5,741		6,025		6,076		6,356		7,384		36,816		

TABLE 3-15

Enrolment in Primary & Junior High Schools Grades 7-11

By Age, Sex and Grade

2008/2009

Age	Sex	Grade 7	Grade 8	Grade 9	Grade 10	Grade 11	Total 7 - 11	Grand Total
10	M	1					1	
11	M	41	2				43	
	F	12	10				22	65
12	M	2438	121				2559	
	F	1501	21				1522	4081
13	M	1698	2737	110			4545	
	F	802	1763	45			2610	7155
14	M	83	1535	2974	2		4594	
	F	36	856	2217			3109	7703
15	M		114	1497	130		1741	
	F	1	38	864	30	1	934	2675
16	M		1	78	57	16	152	
	F		2	45	23	4	74	226
17	M			2	7	35	44	
	F			1	6	3	10	54
18	M					11	11	
	F					3	3	14
Total	M	4261	4510	4661	196	62	13690	
	F	2352	2690	3172	59	11	8284	21974
Grand Total		6613	7200	7833	255	73	21974	

TABLE 3-16

Enrolment in Primary & Junior High Schools Grades 7-11

By Parish, Grade and Sex

2008/2009

Parish	Grade 7		Grade 8		Grade 9		Grade 10		Grade 11		Total 7 - 11		Total 7 - 11	Grand Total 1 - 11
	M	F	M	F	M	F	M	F	M	F	M	F		
Kingston	276	227	248	248	245	217					769	692	1,461	3,732
St. Andrew	828	612	991	745	946	693					2,765	2,050	4,815	12,221
St. Thomas	72	47	105	54	128	57					305	158	463	1,512
Portland	120	36	97	51	111	87					328	174	502	1,332
St. Mary	221	120	211	120	241	140					673	380	1,053	3,639
St. Ann	262	183	307	200	260	170					829	553	1,382	3,808
Trelawny	76	45	101	45	109	76					286	166	452	1,129
St. James	288	119	310	183	323	276					921	578	1,499	4,985
Hanover	48	11	100	18	40	16					188	45	233	1,856
Westmoreland	217	95	211	85	190	127					618	307	925	2,220
St. Elizabeth	308	150	277	173	285	188					870	511	1,381	2,886
Manchester	392	222	382	262	365	321					1,139	805	1,944	6,694
Clarendon	597	259	579	246	699	470	138	22			2,013	997	3,010	6,975
St. Catherine	556	226	591	260	719	334	58	37	62	11	1,986	868	2,854	5,801
Total	4,261	2,352	4,510	2,690	4,661	3,172	196	59	62	11	13,690	8,284	21,974	58,790
Grand Total		6,613		7,200		7,833		255		73		21,974		

TABLE 3-17

**Enrolment in Secondary High Schools
By Age, Sex and Grade
2008/2009**

Age	Sex	Grade 7	Grade 8	Grade 9	Grade 10	Grade 11	Grade 12	Grade 13	Total 7 - 13	Grand Total
10	M	5							5	
	F	10							10	15
11	M	371	4						375	
	F	609	6						615	990
12	M	11126	502	4					11632	
	F	13254	726	20	1				14001	25633
13	M	5865	11957	699	14				18535	
	F	5337	14293	781	75				20486	39021
14	M	180	5519	11824	510	21			18054	
	F	107	5075	13824	678	19			19703	37757
15	M	4	214	6185	11626	520	7		18556	
	F		104	5551	13552	546	9		19762	38318
16	M		7	841	6539	9611	189	11	17198	
	F	1	2	539	5180	11854	294	7	17877	35075
17	M			51	1046	6409	1086	181	8773	
	F			26	655	5315	1694	242	7932	16705
18	M			6	55	1303	549	854	2767	
	F				43	649	432	1326	2450	5217
19	M			1		121	92	276	490	
	F				1	27	19	277	324	814
Total	M	17551	18203	19611	19790	17985	1923	1322	96385	
	F	19318	20206	20741	20185	18410	2448	1852	103160	199545
Grand Total		36869	38409	40352	39975	36395	4371	3174	199545	199545

TABLE 3-18

Enrolment in Secondary High Schools

By Parish, Grade and Sex

2008/2009

Parish	Grade 7		Grade 8		Grade 9		Grade 10		Grade 11		Grade 12		Grade 13		Total 7 - 13		Grand Total 7 - 13
	M	F	M	F	M	F	M	F	M	F	M	F	M	F	M	F	
Kingston	1,857	1,083	1,871	1,182	2,039	1,209	1,975	1,098	1,835	1,001	537	167	398	135	10,512	5,875	16,387
St. Andrew	2,895	3,870	2,868	3,877	3,068	3,955	3,068	3,932	2,785	3,541	452	1,010	330	825	15,466	21,010	36,476
St. Thomas	584	557	606	565	644	596	642	612	631	528	25	42	16	23	3,148	2,923	6,071
Portland	536	602	573	660	689	653	635	667	577	622	101	66	29	44	3,140	3,314	6,454
St. Mary	664	757	717	864	765	863	782	827	747	780	48	92	22	70	3,745	4,253	7,998
St. Ann	772	989	891	1,124	898	1,093	1,136	1,133	942	1,044	9	9	6	2	4,654	5,394	10,048
Trelawny	728	782	671	810	768	918	665	829	628	735	15	19	8	17	3,483	4,110	7,593
St. James	1,276	1,639	1,327	1,596	1,451	1,593	1,566	1,698	1,233	1,451	63		47		6,963	7,977	14,940
Hanover	698	730	678	621	755	747	594	572	608	658	24	33	18	30	3,375	3,391	6,766
Westmoreland	812	841	854	857	967	974	1,061	974	954	900	25	62	23	47	4,696	4,655	9,351
St. Elizabeth	974	1,101	1,038	1,156	1,157	1,214	1,173	1,206	1,096	1,041	105	191	77	128	5,620	6,037	11,657
Manchester	865	1,237	950	1,245	1,198	1,317	1,102	1,187	1,095	1,186	97	131	59	119	5,366	6,422	11,788
Clarendon	1,866	2,172	2,157	2,343	2,005	2,119	2,130	2,041	1,844	1,886	205	304	118	167	10,325	11,032	21,357
St. Catherine	3,024	2,958	3,002	3,306	3,207	3,490	3,261	3,409	3,010	3,037	217	322	171	245	15,892	16,767	32,659
Total	17,551	19,318	18,203	20,206	19,611	20,741	19,790	20,185	17,985	18,410	1,923	2,448	1,322	1,852	96,385	103,160	199,545
Grand Total		36,869		38,409		40,352		39,975		36,395		4,371		3,174		199,545	

TABLE 3-19

**Enrolment in Technical High Schools
By Age, Sex and Grade
2008/2009**

Age	Sex	Grade 7	Grade 8	Grade 9	Grade 10	Grade 11	Grade 12	Grade 13	Total 7 - 13	Grand Total
11	M	15							15	
	F	28							28	43
12	M	784	15	8					807	
	F	965	13	6					984	1791
13	M	417	718	33					1168	
	F	409	925	45					1379	2547
14	M	10	334	856	29				1229	
	F	8	308	815	23				1154	2383
15	M	1	2	1188	1061	16			2268	
	F		5	1281	790	14			2090	4358
16	M			481	1181	652	23	13	2350	
	F			390	1182	736	11		2319	4669
17	M			54	510	1189	102	9	1864	
	F			35	446	944	203	22	1650	3514
18	M			3	63	512	77	49	704	
	F				64	507	99	128	798	1502
19	M					65	37	32	134	
	F					55	31	38	124	258
Total	M	1227	1069	2623	2844	2434	239	103	10539	
	F	1410	1251	2572	2505	2256	344	188	10526	21065
Grand Total		2637	2320	5195	5349	4690	583	291	21065	21065

TABLE 3-20

Enrolment in Technical High Schools

By Parish, Grade and Sex

2008/2009

Parish	Grade 7		Grade 8		Grade 9		Grade 10		Grade 11		Grade 12		Grade 13		Total 7 - 13		Grand Total 7 - 13
	M	F	M	F	M	F	M	F	M	F	M	F	M	F	M	F	
Kingston	23	21			204	359	355	371	326	331					908	1,082	1,990
St. Andrew					248	189	235	222	177	167	43	38	6	10	709	626	1,335
St. Thomas	122	130	126	148	132	177	136	172	135	149	27	35	7	5	685	816	1,501
St. Mary	104	126	110	104	128	108	112	108	119	95					573	541	1,114
St. Ann	200	236	221	240	365	346	298	270	243	246					1,327	1,338	2,665
St. James	112	125	109	122	158	161	154	170	173	150	28	45	13	29	747	802	1,549
Hanover	111	92	98	120	97	107	142	104	99	96					547	519	1,066
Westmoreland	100	123	104	123	160	162	149	167	163	148	12	28	11	22	699	773	1,472
St. Elizabeth	127	154	111	157	150	164	211	181	163	179	37	42	23	30	822	907	1,729
Manchester					426	343	415	145	153	158	34	42	13	21	1,041	709	1,750
Clarendon	114	154			167	196	273	247	284	214	16	31	7	21	861	863	1,724
St. Catherine	214	249	190	237	388	260	364	348	399	323	42	83	23	50	1,620	1,550	3,170
Total	1,227	1,410	1,069	1,251	2,623	2,572	2,844	2,505	2,434	2,256	239	344	103	188	10,539	10,526	21,065
Grand Total		2,637		2,320		5,195		5,349		4,690		583		291		21,065	

TABLE 3-21

**Enrolment in Agricultural High
By Age, Sex and Grade
2008/2009**

Age	Sex	Grade 9	Grade 10	Grade 11	Grade 12	Total 10-12	Grand Total
14	M	1				1	
15	M	9	6		1	16	
	F	11	4	1		16	32
16	M	14	32	5	1	52	
	F	10	8			18	70
17	M	21	38	11	4	74	
	F	3	33	8	2	46	120
18	M		12	13	6	31	
	F	1	14	19	5	39	70
19	M			13	9	22	
	F		4	20	8	32	54
Total	M	45	88	42	21	196	
	F	25	63	48	15	151	347
Grand Total		70	151	90	36	347	347

TABLE 3-22

Enrolment in Agricultural High
By Parish, Grade and Sex
2008/2009

Parish	Grade 9		Grade 10		Grade 11		Grade 12		Total 9 - 12		Total 9 - 12
	M	F	M	F	M	F	M	F	M	F	
Hanover			25	23	26	17	21	15	72	55	127
St. Elizabeth	45	25	63	40	16	31			124	96	220
Total	45	25	88	63	42	48	21	15	196	151	347
Grand Total		70		151		90		36		347	

TABLE 3-23

Number of Repeaters by Grade, Sex and School Type: Grades 1-6

2008/2009

School Type	Grade 1		Grade 2		Grade 3		Grade 4		Grade 5		Grade 6		Total 1 - 6		Grand Total
	M	F	M	F	M	F	M	F	M	F	M	F	M	F	
Primary	979	446	310	173	221	88	520	194	460	303	1,798	2,003	4,288	3,207	7,495
Primary and Infant							2				2		4		4
All Age	253	129	79	23	57	25	118	44	81	45	719	562	1,307	828	2,135
Primary & Junior High	113	42	75	30	65	16	137	52	170	95	356	333	916	568	1,484
Total	1,345	617	464	226	343	129	777	290	711	443	2,875	2,898	6,515	4,603	11,118
Grand Total		1,962		690		472		1,067		1,154		5,773		11,118	11,118

TABLE 3-24

Number of Repeaters by Grade, Sex and School Type: Grades 7-12

2008/2009

School Type	Grade 7		Grade 8		Grade 9		Grade 10		Grade 11		Grade 12		Total 7 - 12		Grand Total
	M	F	M	F	M	F	M	F	M	F	M	F	M	F	
All Age	41	45	35	11	98	31							174	87	261
Primary & Junior High	54	13	37	20	63	17	9	1	17	1			180	52	232
Secondary High	86	33	85	46	248	143	318	134	1,231	438	39	12	2,007	806	2,813
Technical High			2	1	13	23	38	18	199	51	1		253	93	346
Agricultural High					3								3		3
Total	181	91	159	78	425	214	365	153	1,447	490	40	12	2,617	1,038	3,655
Grand Total		272		237		639		518		1,937		52		3,655	3,655

TABLE 3 - 25 PROMOTION, REPETITION AND DROP-OUT RATES IN PUBLIC PRIMARY LEVEL EDUCATION BY GRADE AND SEX 2007/2008

INTERNAL EFFICIENCY INDICATORS	GRADE					
	1-2	2-3	3-4	4-5	5-6	6-7
PROMOTION RATES	98.0	98.9	98.5	96.0	97.0	-
MALE	96.3	98.0	97.8	94.0	95.7	-
FEMALE	99.9	99.9	99.2	98.1	98.4	-
REPETITION RATES	4.4	1.4	1.1	2.3	2.3	10.8
MALE	5.8	1.9	1.5	3.3	2.8	10.9
FEMALE	2.5	0.8	0.8	1.5	1.6	8.8
DROP-OUT RATES	-2.4	-0.3	0.4	1.7	0.7	-
MALE	-2.1	0.1	0.7	2.7	1.5	-
FEMALE	-2.7	-0.8	0.2	0.6	-0.2	-

Promotion and drop-out rates from grades 6 - 7 are not calculated as grade 6 marks the end of primary level

TABLE 3 -26 PROMOTION, REPETITION AND DROP-OUT RATES IN PUBLIC SECONDARY LEVEL EDUCATION BY GRADE AND SEX 2007/2008

INTERNAL EFFICIENCY INDICATORS	GRADE					
	7-8	8-9	9-10	10-11	11-12	12-13
PROMOTION RATES	98.6	109.6	-	88.9	-	77.3
MALE	100.5	111.3	-	87.8	-	82.3
FEMALE	96.7	107.8	-	89.9	-	74.1
REPETITION RATES	0.4	0.4	0.9	1.1	3.5	0.5
MALE	0.7	0.6	1.5	1.7	7.0	2.3
FEMALE	2.8	0.9	0.6	1.3	1.8	10.7
DROP-OUT RATES	0.9	-10.0	-	9.9	-	21.4
MALE	-1.2	-11.9	-	10.5	-	15.4
FEMALE	2.9	-8.1	-	9.4	-	25.2

Promotion and drop-out rates from grades 9-10 and grades 11-12 cannot be calculated as most students in All Age and Primary & Junior High schools complete the secondary level at grade 9. For other secondary schools, students terminate at grade 11.

TABLE 3 - 27

**ENROLMENT IN COMMUNITY COLLEGES BY SEX
2008/2009**

COLLEGE	MALES		TOTAL MALES	FEMALES		TOTAL FEMALES	GRAND TOTAL
	Full Time	Evening/Part Time		Full Time	Evening/Part Time		
Brown's Town	422	-	422	705	-	705	1127
Excelsior	367	73	440	874	184	1058	1498
Knox	593	18	611	872	49	921	1532
*Moneague	147	45	192	437	222	659	851
Montego Bay	495	178	673	1018	412	1430	2103
**CASE	254	-	254	417	-	417	671
***Bethlehem	11	-	11	166	-	166	177
Portmore	449	476	925	729	1035	1764	2689
Total	2738	790	3528	5218	1902	7120	10648

* The Community College section of Moneague College

** The Community College section of CASE

*** The Community College section of Bethlehem Moravian College

TABLE 3 - 28

**ENROLMENT AT EDNA MANLEY COLLEGE OF THE VISUAL
AND PERFORMING ARTS BY SCHOOL, PROGRAMME AND SEX
2008/2009**

SCHOOL	DEGREE		DIPLOMA		CERTIFICATE				TOTAL		GRAND TOTAL
	M	F	M	F	M		F		M	F	
					F/T	P/T	F/T	P/T			
ARTS	117	101	78	93	10	-	2	4	205	200	405
TOTAL	117	101	78	93	10	0	2	4	205	200	405
GRAND TOTAL*	218		171		16				405		

* Does not include Teacher Training Programmes

TABLE 3 - 29

**ENROLMENT IN TEACHER TRAINING PROGRAMMES
BY YEAR, INSTITUTION & SEX
2008/2009**

COLLEGE	Sex	EARLY CHILDHOOD EDUCATION				PRIMARY EDUCATION				SECONDARY EDUCATION				SPECIAL EDUCATION				GUIDANCE & COUNSELLING				TOTAL	GRAND TOTAL
		FIRST YEAR	SECOND YEAR	THIRD YEAR	PART TIME	FIRST YEAR	SECOND YEAR	THIRD YEAR	PART TIME	FIRST YEAR	SECOND YEAR	THIRD YEAR	PART TIME	FIRST YEAR	SECOND YEAR	THIRD YEAR	PART TIME	FIRST YEAR	SECOND YEAR	THIRD YEAR	PART TIME		
*BETHLEHEM	M	-	-	-	-	15	20	13	-	5	2	5	****3	-	-	-	-	-	-	-	-	63	543
	F	-	-	-	-	135	131	114	-	29	24	24	****23	-	-	-	-	-	-	-	-	480	
CHURCH	M	2	1	-	-	-	-	-	-	22	16	15	*4	-	-	-	-	-	-	-	-	60	412
	F	18	14	17	-	7	8	-	-	84	108	91	*5	-	-	-	-	-	-	-	-	352	
G.C. FOSTER	M	-	-	-	-	-	-	-	-	65	75	61	**69	-	-	-	-	-	-	-	-	270	566
	F	-	-	-	-	-	-	-	-	88	85	78	**45	-	-	-	-	-	-	-	-	296	
MICO	M	10	-	-	2	-	6	10	36	-	85	68	176	-	-	1	2	-	14	11	20	441	2517
	F	385	-	-	56	-	50	52	475	-	181	180	401	-	7	11	41	-	69	38	130	2076	
*C.A.S.E	M	-	-	-	-	20	8	13	-	16	3	14	**38	-	-	-	-	-	-	-	-	112	584
	F	-	-	-	-	85	86	81	-	15	10	63	**132	-	-	-	-	-	-	-	-	472	
ST. JOSEPHS	M	-	1	1	-	8	2	4	-	-	-	-	-	-	-	-	-	-	-	-	-	16	705
	F	78	66	71	***39	132	148	133	***22	-	-	-	-	-	-	-	-	-	-	-	-	689	
SAM SHARPE	M	1	-	-	-	12	8	10	2	1	-	-	2	3	2	1	-	3	2	2	-	49	663
	F	48	38	42	**15	121	92	103	17	9	11	9	9	19	17	10	-	20	16	18	-	614	
SHORTWOOD	M	2	3	2	-	-	-	-	-	11	13	12	**2	-	-	-	-	-	-	-	-	45	1089
	F	143	111	130	**70	9	7	-	**1	205	155	193	**20	-	-	-	-	-	-	-	-	1044	
*MONEAGUE	M	-	-	-	-	7	7	11	**2	7	3	1	-	-	-	-	-	-	-	-	-	38	450
	F	-	-	-	-	105	82	102	**39	25	24	35	-	-	-	-	-	-	-	-	-	412	
KNOX	M	-	-	-	-	-	-	1	**3	-	-	-	-	-	-	-	-	-	-	-	-	4	61
	F	-	-	-	-	-	-	30	**27	-	-	-	-	-	-	-	-	-	-	-	-	57	
EDNA MANLEY COLLEGE	M	-	-	-	-	-	-	-	-	3	5	7	-	-	-	-	-	-	-	-	-	15	68
	F	-	-	-	-	-	-	-	-	15	20	18	-	-	-	-	-	-	-	-	-	53	
TOTAL	M	15	5	3	2	62	51	61	43	130	202	183	294	3	2	2	2	3	16	13	20	1112	7627
	F	672	229	260	180	594	604	585	581	470	618	691	635	19	24	21	41	20	85	56	130	6515	

* The Teachers' Training section of the multi-disciplinary colleges

** Students registered for the Bachelors Degree

*** Student registered for Post Certificate

**** Students Registered for the Professional Studies Diploma Programme

¶ Data not submitted

TABLE 3 - 30

**ENROLMENT AT THE COLLEGE OF AGRICULTURE, SCIENCE AND EDUCATION
BY SCHOOL, PROGRAMME AND SEX
2008/2009**

PROGRAMME	DEGREE				DIPLOMA				ASSOCIATE DEGREE				TOTAL		GRAND
	M		F		M		F		M		F		M	F	
	F/T	P/T	F/T	P/T	F/T	P/T	F/T	P/T	F/T	P/T	F/T	P/T			
Agriculture	29	-	27	-	30	-	29	-	60	-	68	-	119	124	243
Architecture & Building		-		-		-		-		-		-	-	-	0
Business & Administration	1	-	13	-	-	-	-	-	34	-	114	-	35	127	162
Hospitality & Tourism Management	-	-	-	-	-	-	-	-	6	-	49	-	6	49	55
Life/Environmental Sciences	31	-	33	-	-	-	-	-	-	-	-	-	31	33	64
Physical/Natural Sciences	-	-	-	-	-	-	-	-	21	-	36	-	21	36	57
Computing	-	-	-	-	-	-	-	-	-	-	-	-	-	-	-
TOTAL	61	0	73	0	30	-	29	-	121	0	267	0	212	369	581
GRAND TOTAL*	134				59				388				581		

* Does not include Teacher Training Programmes

TABLE 3 - 31

**REGISTRATION AT THE UNIVERSITY OF TECHNOLOGY
BY PROGRAMME, SCHOOL/DEPARTMENT AND SEX
2007/2008**

SCHOOL/DEPARTMENT	HIGHER DEGREE	DEGREE	ASSOCIATE DEGREE	DIPLOMA	DIPLOMA (POST-GRAD)	CERTIFICATE	SPECIALLY ADMITTED	TOTAL	GENDER		TOTAL
									M	F	
Caribbean School of Architecture	14	178	-	-	-	-	-	192	118	74	192
Building & Land Management	-	490	-	154	-	179	1	824	607	217	824
Business Administration	104	3723	-	-	-	-	-	3827	1226	2601	3827
Computer & Information Technology	-	1115	35	-	-	117	-	1267	877	390	1267
Engineering	-	549	-	441	-	-	-	990	895	95	990
Hospitality & Tourism Management	-	533	-	-	-	105	-	638	93	545	638
Pharmacy and Health Science	-	775	55	10	-	11	-	851	128	723	851
Mathematics & Science	-	128	8	-	-	17	-	153	76	77	153
Technical and Vocational Education	53	910	-	-	18	2	-	983	329	654	983
TOTAL	171	8401	98	605	18	431	1	9725	4349	5376	9725

Source: University of Technology, April 2009

TABLE 3 - 32

**REGISTRATION OF JAMAICAN UNDERGRADUATE STUDENTS IN DEGREE COURSES
AT THE UNIVERSITY OF THE WEST INDIES BY CAMPUS, FACULTY/SCHOOL AND SEX
2008-2009**

		HUMANITIES			SCHOOL OF EDUCATION			LAW			MEDICAL SCIENCES			PURE AND APPLIED SCIENCES			SOCIAL SCIENCES			ENGINEERING			SCHOOL OF AGRICULTURE			GRAND TOTAL					
		M	F	T	M	F	T	M	F	T	M	F	T	M	F	T	M	F	T	M	F	T	M	F	T	M	F	T			
CAVE HILL	Full Time	0	0	0	0	0	0	0	0	0	0	0	0	0	0	0	0	0	0	0	0	0	0	0	0	0	0	0	0	0	0
	Part Time	0	0	0	0	0	0	0	0	0	0	0	0	0	0	0	0	0	0	0	0	0	0	0	0	0	0	0	0	0	0
	All Students	0	0	0	0	0	0	0	0	0	0	0	0	0	0	0	0	0	0	0	0	0	0	0	0	0	0	0	0	0	0
MONA	Full Time	234	810	1044	28	178	206	17	38	55	197	859	1056	587	850	1437	562	1451	2013	0	0	0	0	0	0	1625	4186	5811			
	Part Time	157	418	575	5	42	47	0	0	0	4	21	25	157	106	263	506	1120	1626	0	0	0	0	0	0	829	1707	2536			
	All Students	391	1228	1619	33	220	253	17	38	55	201	880	1081	744	956	1700	1068	2571	3639	0	0	0	0	0	0	2454	5893	8347			
ST. AUGUSTINE	Full Time	0	1	1	0	1	1	0	0	0	6	28	34	4	1	5	0	0	0	36	7	43	2	5	7	48	43	91			
	Part Time	1	0	1	0	0	0	0	0	0	0	0	0	0	0	0	0	0	0	0	0	0	0	0	0	1	0	1			
	All Students	1	1	2	0	1	1	0	0	0	6	28	34	4	1	5	0	0	0	36	7	43	2	5	7	49	43	92			
ALL CAMPUSES	Total	392	1229	1621	33	221	254	17	38	55	207	908	1115	748	957	1705	1068	2571	3639	36	7	43	2	5	7	2503	5936	8439			

SOURCE: UNIVERSITY OF THE WEST INDIES.
Note: Mona Campus reflects on-campus student enrolment.
Data for Cave Hill is not available at this time

NOTE: Other registrations at St Augustine:
1. 1 PT (f) - Cert. - Humanities
2. 2 FT(f) - Pre-Health - Med. Sci

TABLE 3 - 33

**REGISTRATION OF JAMAICAN GRADUATE STUDENTS IN HIGHER DEGREE COURSES
AT THE UNIVERISTY OF THE WEST INDIES BY CAMPUS, FACULTY/SCHOOL AND SEX
2008-2009**

		HUMANITIES			SCHOOL OF EDUCATION			LAW			MEDICAL SCIENCES			PURE AND APPLIED SCIENCES			SOCIAL SCIENCES			GENDER STUDIES			GRADUATE STUDIES			ENGINEERING			SCHOOL OF AGRICULTURE			GRAND TOTAL					
		M	F	T	M	F	T	M	F	T	M	F	T	M	F	T	M	F	T	M	F	T	M	F	T	M	F	T	M	F	T	M	F	T			
CAVE HILL	Full Time	0	0	0	0	0	0	0	0	0	0	0	0	0	0	0	0	0	0	0	0	0	0	0	0	0	0	0	0	0	0	0	0	0	0	0	0
	Part Time	0	0	0	0	0	0	0	0	0	0	0	0	0	0	0	0	0	0	0	0	0	0	0	0	0	0	0	0	0	0	0	0	0	0	0	0
	All Students	0	0	0	0	0	0	0	0	0	0	0	0	0	0	0	0	0	0	0	0	0	0	0	0	0	0	0	0	0	0	0	0	0	0	0	0
MONA	Full Time	30	74	104	3	35	38	0	0	0	93	228	321	68	118	186	79	151	230	1	5	6	1	0	1	0	0	0	0	0	0	275	611	886			
	Part Time	50	215	265	27	149	176	0	0	0	10	64	74	94	63	157	338	692	1030	0	13	13	3	5	8	0	0	0	0	0	0	522	1201	1723			
	All Students	80	289	369	30	184	214	0	0	0	103	292	395	162	181	343	417	843	1260	1	18	19	4	5	9	0	0	0	0	0	0	797	1812	2609			
ST. AUGUSTINE	Full Time	0	3	3	0	0	0	0	0	0	0	1	1	0	0	0	1	1	2	0	0	0	0	0	0	9	4	13	4	1	5	14	10	24			
	Part Time	0	0	0	0	0	0	0	0	0	3	0	3	1	1	2	2	1	3	0	0	0	0	0	0	11	2	13	4	1	5	21	5	26			
	All Students	0	3	3	0	0	0	0	0	0	3	1	4	1	1	2	3	2	5	0	0	0	0	0	0	20	6	26	8	2	10	35	15	50			
ALL CAMPUSES	Total	80	292	372	30	184	214	0	0	0	106	293	399	163	182	345	420	845	1265	1	18	19	4	5	9	20	6	26	8	2	10	832	1827	2659			

SOURCE: UNIVERSITY OF THE WEST INDIES.

Note: Mona Campus reflects on-campus student enrolment.
Data for Cave Hill is not available at this time

TABLE 3-34

**REGISTRATION OF JAMAICAN STUDENTS FOR CERTIFICATE AND DIPLOMA
COURSES AT THE UNIVERSITY OF THE WEST INDIES, MONA CAMPUS
BY FACULTY AND SEX
2008-2009**

PROGRAMME	FULL TIME			PART TIME			GRAND TOTAL		
	MALE	FEMALE	TOTAL	MALE	FEMALE	TOTAL	MALE	FEMALE	TOTAL
CERTIFICATE									
MEDICAL SCIENCES	0	0	0	0	0	0	0	0	0
SUB-TOTAL	0	0	0	0	0	0	0	0	0
DIPLOMA									
HUMANITIES	4	2	6	0	0	0	4	2	6
EDUCATION	0	0	0	0	1	1	0	1	1
SOCIAL SCIENCES	3	5	8	7	21	28	10	26	36
MEDICAL SCIENCES	0	0	0	0	0	0	0	0	0
SUB-TOTAL	7	7	14	7	22	29	14	29	43
ADVANCED DIPLOMA									
PURE & APPLIED SCIENCES	0	0	0	7	5	12	7	5	12
EDUCATION	1	1	2	2	13	15	3	14	17
SOCIAL SCIENCES	1	0	1	0	2	2	1	2	3
SUB-TOTAL	2	1	3	9	20	29	11	21	32
TOTAL	9	8	17	16	42	58	25	50	75

SOURCE: UNIVERSITY OF THE WEST INDIES.
Mona Campus reflects on-campus student enrolment.

Table 3 - 35

**Enrolment in Selected Independent Tertiary Institutions by Gender
2007/2008**

Institution	Male	Female	Total
B & B Institute	42	157	199
Caribbean Institute of Technology	610	182	792
Caribbean Maritime Institute	540	165	705
Dental Auxillary School	0	12	12
International University of the Caribbean	128	581	709
Institute of Chartered Accountants of Jamaica	1385	3492	4877
Management Institute of National Development	985	3466	4451
Northern Caribbean University	1191	4002	5193
Nursing Schools - UWI	0	182	182
Nursing School	0	84	84
School of Physical Therapy	11	44	55
University College of the Caribbean	816	2560	3377
Vocational Training Development Institute	1507	1678	3185
Total	7215	16605	23821

Source: Economic and Social Survey Jamaica 2007

Table 3-36a

**Enrolment in Special Education Institutions by Parish, Sex and Area of Disability
(2008/2009)**

PARISH	Blind and Visually Impaired Only		Deaf & Hearing Impaired Only		Learning Disabilities Only		Mentally Retarded Only		Multiple Disabilities	
	Male	Female	Male	Female	Male	Female	Male	Female	Male	Female
Kingston	48	48	8	-	116	69	124	173	189	30
St. Andrew	1	-	116	102	73	38	488	317	144	98
St. Thomas	-	-	-	1	16	6	17	11	-	-
St. Ann	-	-	20	-	4	14	86	40	38	18
Trelawny	-	-	-	-	4	2	-	-	2	3
St. James	-	-	47	26	-	7	-	10	9	-
Westmoreland	1	-	-	-	-	-	88	24	32	49
St. Elizabeth	-	-	11	10	-	-	-	-	1	1
Manchester	-	-	49	31	45	35	32	20	28	26
Clarendon	1	-	-	-	12	3	27	26	1	1
St. Catherine	-	-	-	-	-	-	190	64	-	-
Total	51	48	251	170	270	174	1052	685	444	226
Grand Total	99		421		444		1737		670	

Table 3-36b

**Enrolment in Special Education Institutions by Parish, Sex and Area of Disability (continued)
(2008/2009)**

PARISH	Physical Disabilities		Autism		Attention Deficit Hyperactivity Disorder		Speech & Language Disabilities		Other Disabilities		Grand Total	
	Male	Female	Male	Female	Male	Female	Male	Female	Male	Female	Male	Female
Kingston	35	23	2	8	-	-	-	-	25	12	547	363
St. Andrew	46	26	4	1	13	3	66	55	76	50	1027	690
St. Thomas	1	1	-	1	9	-	6	-	-	-	49	20
St. Ann	5	2	-	-	-	1	1	1	1	-	155	76
Trelawny	-	-	1	-	-	-	-	-	-	-	7	5
St. James	-	-	4	-	1	-	-	-	-	-	61	43
Westmoreland	-	18	-	-	-	-	-	-	-	-	121	91
St. Elizabeth	2	-	-	-	-	-	-	1	-	-	14	12
Manchester	6	5	10	3	6	1	35	29	151	-	362	150
Clarendon	-	-	1	1	2	-	1	-	-	2	45	33
St. Catherine	35	13	52	15	8	8	62	18	48	17	395	135
Total	130	88	74	29	39	13	171	104	301	81	2783	1618
Grand Total	218		103		52		275		382		4401	

TABLE 3 - 37

**DISTRIBUTION OF ENROLMENT BY LEVEL AND SCHOOL TYPE
2004/2005 TO 2008/2009**

	2004			2005			2006			2007			2008		
EARLY CHILDHOOD LEVEL	MALE	FEMALE	TOTAL	MALE	FEMALE	TOTAL	MALE	FEMALE	TOTAL	MALE	FEMALE	TOTAL	MALE	FEMALE	TOTAL
Infant Schools	4,293	4,075	8,368	4,241	4,022	8,263	4,060	3,914	7,974	3,873	3,954	7,827	3,984	3,925	7,909
Infant Dept. (Primary)	2,034	2,162	4,196	2,147	2,244	4,391	2,234	2,262	4,496	2,277	2,245	4,522	2,181	2,215	4,396
Infant Dept. (All Age)	452	406	858	424	369	793	394	306	700	397	387	784	218	197	415
Infant Dept. (Prim. & Junior High)	329	254	583	90	121	211	124	97	221	129	100	229	127	106	233
Subtotal	7,108	6,897	14,005	6,902	6,756	13,658	6,812	6,579	13,391	6,676	6,686	13,362	6,510	6,443	12,953
PRIMARY LEVEL															
Primary (Grades 1 - 6)	94,850	93,207	188,057	93,736	93,214	186,950	96,891	95,713	192,604	95,694	93,954	189,648	100,629	98,470	199,099
All Age (Grades 1 - 6)	34,363	30,523	64,886	32,669	28,946	61,615	27,036	24,392	51,428	25,977	23,216	49,193	18,901	16,906	35,807
Prim. & Junior High (Grades 1 - 6)	24,675	22,668	47,343	22,879	20,973	43,852	21,850	19,852	41,702	20,558	18,739	39,297	19,328	17,488	36,816
Subtotal	153,888	146,398	300,286	149,284	143,133	292,417	145,777	139,957	285,734	142,229	135,909	278,138	138,858	132,864	271,722
SECONDARY LEVEL															
All Age (Grades 7 - 9)/10	8,100	3,588	11,688	7,444	3,585	11,029	7,034	3,488	10,522	6,615	3,201	9,816	6,228	2,665	8,893
Junior High/Prim. & Junior High (Grades 7 - 9/11)	14,086	8,204	22,290	13,511	8,541	22,052	14,042	9,204	23,246	13,788	9,132	22,920	13,690	8,284	21,974
Secondary High	86,198	99,366	185,564	86,198	99,366	185,564	91,413	101,838	193,251	93,328	103,805	197,133	96,385	103,160	199,545
Technical High	8,915	9,116	18,031	8,732	8,745	17,477	10,017	9,992	20,009	10,477	10,147	20,624	10,539	10,526	21,065
Vocational/Agricultural High	198	92	290	188	100	288	146	120	266	203	141	344	196	151	347
Subtotal	117,497	120,366	237,863	116,073	120,337	236,410	122,652	124,642	247,294	124,411	126,426	250,837	127,038	124,786	251,824
TERTIARY LEVEL															
Community Colleges	3,254	4,845	8,099	2,797	5,680	8,477	2,539	4,749	7,288	3,049	5,117	8,166	3,075	5,935	9,010
Teacher's Colleges	491	3,181	3,672	200	2,221	2,421	502	3,340	3,842	389	3,802	4,191	610	4,776	5,386
Moneague College	216	1,110	1,326	216	781	997	278	1,053	1,331	174	823	997	230	1,071	1,301
Bethlehem	176	876	1,052	95	646	741	111	691	802	115	784	899	74	646	720
Edna Manley College of the Visual & Performing Arts	390	423	813	541	719	1,260	252	219	471	414	367	781	220	253	473
College of Agriculture, Science & Education	301	575	876	305	603	908	266	633	899	255	568	823	366	889	1,255
G.C. Foster College of Physical Education & Sports	122	110	232	n/a	n/a	n/a	167	155	322	347	283	630	270	296	566
University of Technology	4,047	4,830	8,877	4,071	4,732	8,803	n/a	n/a	n/a	4,349	5,376	9,725	-	-	-
University of the West Indies	3,009	7,682	10,691	3,197	8,010	11,207	3,074	7,651	10,725	3,157	7,603	10,760	3,276	7,755	11,031
Subtotal	12,006	23,632	35,638	11,422	23,392	34,814	7,189	18,491	25,680	12,249	24,723	36,972	8,121	21,621	29,742
Grand Total	290,499	297,293	587,792	283,681	293,618	577,299	282,430	289,669	572,099	285,565	293,744	579,309	280,527	285,714	566,241

Enrolment Data for University of Technology not submitted for 2006/2007 and 2008/2009

EXAMINATION

STATISTICS

Examination Statistics

OVERVIEW

The Grade One Individual Learning Profile (GOILP)

The **Grade One Individual Learning Profile (GOILP)** was administered for the first time in 2008. It replaces the Grade One Readiness Inventory. The GOILP measures the proficiency level of students in six subtests, namely general knowledge, number concepts, oral language, reading, writing and drawing, work habits and classroom behaviour.

For the academic year 2007/2008, a total of 41,080 students sat the examination. This represents a 2.3 percent decline in the number of students who sat the Grade 1 Readiness Inventory in 2006/2007. The data also showed that more boys than girls were tested; 21,397 boys to 19,683 girls consistent with the enrolment in Grade one. The percentage of students who mastered five subsets vary among school types: Primary 22.0 (boys 16.4 and girls 27.9), All Age 15.3 (boys 11.5 and girls 19.7), Primary and Junior High 17.2 (boys 12.7 and girls 22.5) and Kindergarten/Preparatory 53.7 (boys 49.8 and girls 57.6).

The Grade Four Literacy Test

The **Grade Four Literacy Test** is designed to test the literacy levels of children in grade 4 and identify any additional support that students might need to ensure they are performing at the required grade level. The Test is administered at the end of Grade four, prior to entering Grade five. Students are examined on three components, word recognition, reading comprehension and writing task. The students' performance is categorized as Mastery, Near Mastery and Non-Mastery.

For the academic year 2007/2008, a total of 46,389 students (boys 23,633 and girls 22,756) sat the test at the first administration. Students' performance on the Grade Four Literacy Test improved significantly over that of the last academic year. Table 4-2a indicates that the national mean scores moved from 63.5 percent (boys 53.2 and girls 76.6), in 2006/2007 to 71.7 percent (boys 61.0 and girls 82.9) in 2007/2008. Table 4-2b indicates that students achieved the highest scores in word recognition, 87.9 in 2007/2008, compared to 83.5 in 2006/2007.

Examination Statistics

Grade Six Achievement Test

The **Grade Six Achievement Test (GSAT)** is a curriculum-based examination. The items on the examination are based on materials covered in the Grade 4 to Grade 6 curricula. The test is used to place students at the secondary level based on their overall performance on the subject areas tested.

The test consists of Mathematics, Science, Language Arts, Social Studies and Communication Task. The national mean scores for Mathematics was 55, Science 52, Language Arts 53, Social Studies 60 and Communication Task 7 (out of a possible 12). Girls continued to out-perform boys in all subject areas and across all regions.

Grade Nine Achievement Test (GNAT)

The **Grade Nine Achievement Test (GNAT)** is offered to students in Grade 9 at All Age and Primary and Junior High schools. Awardees are placed in Secondary High and Technical High Schools. For the year under review 2007/2008, some 7,288 students (3,000 females and 4,288 males) sat Mathematics and 7,268 students (2,978 females, 4,290 males) sat Language Arts. Students' performance in GNAT improved significantly over that of the last academic year. The National mean scores for Mathematics moved from 35 to 40, and the scores for Language Arts moved from 42 to 47. Students in Region one and Region five had the highest average scores in Mathematics and Language Arts, while, students in Region four had the lowest average scores.

Caribbean Secondary Education Certificate (CSEC)

The **Caribbean Secondary Education Certificate (CSEC)** is a terminal examination and is usually taken at the end of Grade 11. Some subjects include a School Based Assessment (SBA) component which contributes to the final grade awarded.

For matriculation purposes emphasis is placed on performance in key subject areas, including Mathematics, English Language, Information Technology and the sciences. For 2007/2008, some 37 percent of the entries for Mathematics achieved Grades I to III, an improvement over the 29.6 percent for the previous academic year. English Language suffered a decline in percentage passes when the results for the corresponding periods were compared. For 2006/2007, approximately 45.1 percent of those who sat achieved Grades I to

Examination Statistics

III, compared with 43.5 percent for 2007/2008. There was also an improvement in results for Information Technology, with 78.5 percent of candidates sitting obtained Grades I to III, up from 75.3 for 2006/2007. For Physics 77 percent of the entries achieved Grades I to III compared with 51 percent for the previous year. Human and Social Biology saw a 17 percent improvement in performance when compared with 2006/2007. For 2007/2008, approximately 68 percent of entries achieved Grades I to III compared with 51 percent for the year before. Seventy-seven percent of entries for Biology achieved Grades I to III compared with 72 percent for the previous year.

Two other science subjects, Chemistry and Integrated Science recorded a four percent improvement over 2006/2007. Sixty-eight percent of entries for Chemistry achieved Grades I to III compared with 64 percent last year, while for Integrated Science, 85 percent of entries achieved acceptable grades as against 81 percent last year. Economics showed the most improvement with 68 percent of entries achieving Grades I to III while for 2006/2007 the number was 56 percent. Principles of Business had a four percent increase in performance with 75 percent of the entries achieving acceptable grades compared with 71 percent last year. Performance in Principles of Accounts declined by two percent; 63 percent of entries achieved acceptable grades compared to 65 percent last year. Although performance in Office Administration continues to be excellent, there was a three percent decline when compared with last year. This year 82 percent of entries achieved acceptable grades, with 85 percent doing so for the previous year. Candidates continue to perform very well in Electronic Document Preparation and Management (EDPM) with 95 percent of the entries achieving acceptable grades.

Caribbean Advanced Proficiency Examinations (CAPE)

The **Caribbean Advanced Proficiency Examination (CAPE)** is designed to provide certification of the academic, vocational and technical achievement of students who, having completed five years of secondary education, and have obtained the required grades, wish to pursue further studies. The examinations address the skills and knowledge acquired by students under a flexible and articulated system where subjects are organized in 1-Unit or 2-Unit courses with each unit containing three modules.

For 2007/2008, Computer Science showed significant improvement over the performance in 2006/2007. Approximately 99.7 percent of the entries in unit 1 (table4-9), achieved Grades I to V, which is a 21 percent improvement over the previous year. Also in Unit 2, approximately 98.6 percent of entries achieved Grades I to V compared with 63 percent in 2006/2007, which is a 35 percent improvement in performance.

Examination Statistics

Performance in both Units of Environmental Science improved when compared with last year's. Ninety-four percent of entries submitted for Unit 2 achieved Grades I to V, compared with 74 percent in 2007; while 92 percent of entries submitted for Unit 1 achieved similar Grades, compared with 83 percent in 2007. In Unit 2, students achieved 100 percent acceptable Grade performances in Art and Design, and Electrical and Electronic Technology. Males also achieved 100 percent in Information Technology, Art and Design and French in Unit 1.

Table 4-1

**Grade One Individual Learning Profile
Student Performance by Subtest and Sex
2008/2009**

School Type	Gender	Number Sitting	Percentage Proficient by Number of Subtests					
			5	4	3	2	1	0
Primary	Male	13311	16.4	19.6	15.6	12.9	13.0	22.6
	Female	12594	27.9	23.5	16.2	10.4	7.7	14.3
	Total	25905	22.0	21.5	15.9	11.7	10.4	18.6
All Age	Male	3577	11.5	15.3	14.0	12.9	15.0	31.3
	Female	3022	19.7	22.2	17.4	10.9	10.6	19.2
	Total	6599	15.2	18.5	15.5	12.0	13.0	25.8
Primary & Junior High	Male	2521	12.7	16.4	16.1	14.2	13.9	26.7
	Female	2132	22.5	22.2	17.3	13.2	9.8	15.0
	Total	4653	17.2	19.1	16.6	13.7	12.1	21.3
Kindergarten/Preparatory	Male	1988	49.8	24.4	12.3	6.3	3.4	3.7
	Female	1935	57.6	24.9	10.3	3.0	2.1	2.1
	Total	3923	53.7	24.7	11.3	4.7	2.8	2.9
National	Male	21397	18.3	18.9	15.1	12.4	12.5	22.8
	Female	19683	29.0	23.3	15.9	10.0	7.8	13.9
	Total	41080	23.4	21.0	15.5	11.3	10.3	18.5

NB. Results for subtest six is not available at this time

Source: Student Assessment Unit, Ministry of Education, March 2009

TABLE 4 - 2a

**Grade 4 Literacy Test (First Sitting)
2007/2008**

REGIONS		Number Sitting	Percentage Mastering All 3 Skill Cognitive Areas Or Less			
			3	2	1	0
Region 1 (Kingston)	Total	10428	75.3	9.8	8.4	6.5
	Male	5179	65.7	12.4	12.1	9.8
	Female	5249	84.8	7.2	4.7	3.3
Region 2 (Port Antonio)	Total	3638	69.7	11.3	10.0	9.1
	Male	1930	57.8	14	14.5	13.7
	Female	1708	83	8.2	4.9	3.9
Region 3 (Brown's Town)	Total	5834	67.8	11.1	9.6	11.6
	Male	2915	55.1	13.9	13.8	17.3
	Female	2919	80.4	8.2	5.4	5.9
Region 4 (Montego Bay)	Total	7433	71.5	11.0	8.3	9.2
	Male	3871	60.8	13.6	11.7	13.9
	Female	3562	83.1	8.2	4.7	4.1
Region 5 (Mandeville)	Total	5724	68.0	10.8	10.1	11.1
	Male	2989	55.5	13	14.4	17.1
	Female	2735	81.6	8.4	5.4	4.6
Region 6 (Old Harbour)	Total	13332	73.0	10.4	7.8	8.8
	Male	6749	63.3	12.9	10.8	12.9
	Female	6583	83	7.8	4.6	4.6
Grand Total		46389	71.7	10.6	8.7	9.0
Male		23633	61.0	13.2	12.4	13.5
Female		22756	82.9	7.9	4.9	4.3

Source: Student Assessment Unit, Ministry of Education

Table 4-2b

**Grade 4 Literacy by Region and Subject (First Sitting)
(2007/2008)**

Region		Number Sitting	Subjects								
			Word Recognition			Reading Comprehension			Writing		
			M	NM	NR	M	NM	NR	M	NM	NR
Region 1 (Kingston)	Total	10428	91.1	8.7	0.2	80.4	19.3	0.3	82.5	16.4	1.2
	Male	5179	94.9	5.0	0.1	72.3	27.2	0.5	75.0	23.7	1.3
	Female	5249	95.3	4.5	0.2	88.3	11.5	0.2	89.8	9.1	1.1
Region 2 (Port Antonio)	Total	3638	87.4	12.5	0.1	75.7	24.2	0.1	78.4	21.0	0.5
	Male	1930	80.7	19.2	0.1	66.2	33.6	0.2	69.1	30.2	0.7
	Female	1708	94.9	5.0	0.1	86.4	13.5	0.1	89.0	10.6	0.4
Region 3 (Brown's Town)	Total	5834	84.8	15.1	0.1	73.4	26.4	0.2	76.8	22.8	0.3
	Male	2915	78.0	21.9	0.1	62.5	37.3	0.2	66.3	33.4	0.3
	Female	2919	91.5	8.4	0.1	84.3	15.6	0.1	87.4	12.3	0.3
Region 4 (Montego Bay)	Total	7433	43.0	8.4	0.1	76.9	23.0	0.1	80.7	19.1	0.2
	Male	3871	81.2	18.6	0.2	67.9	32.0	0.1	72.1	27.7	0.2
	Female	3562	93.6	6.3	0.1	86.6	13.3	0.1	90.0	9.8	0.2
Region 5 (Mandeville)	Total	5724	85.7	14.2	0.1	74.2	25.6	0.2	75.7	23.5	0.8
	Male	2989	78.3	21.5	0.1	63.8	36.0	0.2	64.8	34.3	0.9
	Female	2735	93.7	6.2	0.0	85.6	14.3	0.1	87.6	11.7	0.6
Region 6 (Old Harbour)	Total	13332	46.1	9.4	0.2	78.4	21.4	0.2	81.1	18.0	0.8
	Male	6749	82.9	16.7	0.4	70.7	29.0	0.3	73.0	26.0	1.0
	Female	6583	93.5	6.4	0.1	86.2	13.7	0.1	89.5	9.9	0.6
National	Grand Total	46389	87.9	12.0	0.2	77.2	22.6	0.2	79.9	19.3	0.7
	Male	23633	82.1	17.6	0.2	68.3	31.4	0.3	71.1	28.1	0.8
	Female	22756	93.8	6.1	0.1	86.5	13.4	0.1	89.1	10.3	0.6

M - Mastery

NM - Non Mastery

NR - No Response

Source: Student Assessment Unit

TABLE 4-3

**GRADE SIX ACHIEVEMENT TEST(GSAT)
MEAN SCORES BY SUBJECT AND REGION
2007/2008**

Subject	Number of Candidates Sitting	Regional and National Mean Scores						
		Region 1	Region 2	Region 3	Region 4	Region 5	Region 6	National
MATHEMATICS	48698	59	51	52	54	54	53	55
FEMALE	24370	63	56	57	59	59	57	59
MALE	24328	55	47	47	49	50	48	50
SCIENCE	48713	56	50	50	53	53	50	52
FEMALE	24376	58	53	54	57	57	53	55
MALE	24337	53	46	46	49	49	47	49
SOCIAL STUDIES	48704	60	53	53	56	56	54	56
FEMALE	24371	63	58	58	61	61	58	60
MALE	24333	57	48	48	51	52	50	51
LANGUAGE ARTS	48720	57	49	50	53	53	51	53
FEMALE	24379	61	55	56	58	58	56	58
MALE	24341	53	44	45	47	47	46	48
COMPOSITION	48717	7	7	7	7	7	7	7
FEMALE	24377	7	8	8	8	8	7	8
MALE	24340	6	6	6	6	6	6	6

*All subjects are marked out of 100 points with the exception of Composition, which is marked out of 12

Source: Student Assessment Unit, Ministry of Education

TABLE 4-4

**GRADE NINE ACHIEVEMENT EXAMINATIONS
AVERAGE SCORES BY SUBJECT AND REGION
2007/2008**

Subject	Number of Candidates Sitting	Regional and National Average						
		Region 1	Region 2	Region 3	Region 4	Region 5	Region 6	National
MATHEMATICS	7288	44	38	41	36	43	36	40
FEMALE	3000	47	42	46	41	47	40	44
MALE	4288	41	35	39	33	41	34	37
LANGUAGE ARTS	7268	53	46	47	43	50	42	47
FEMALE	2978	58	54	54	49	55	49	53
MALE	4290	49	42	43	38	46	38	43

Source: Student Assessment Unit, Ministry of Education, March 2009

TABLE 4 - 5

**CARIBBEAN SECONDARY EDUCATION CERTIFICATE: TOTAL NUMBER OF CANDIDATES SITTING
& PERCENTAGE ATTAINING GRADES 1, 2 & 3 AT THE GENERAL PROFICIENCY LEVEL
BY SEX
2007/2008**

SUBJECT	SEX	NUMBER SITTING	NUMBER ATTAINING GRADES 1&2	PERCENTAGE ATTAINING GRADES 1&2	NUMBER ATTAINING GRADE 3	PERCENTAGE ATTAINING GRADES 1,2&3	SUBJECT	SEX	NUMBER SITTING	NUMBER ATTAINING GRADES 1&2	PERCENTAGE ATTAINING GRADES 1&2	NUMBER ATTAINING GRADE 3	PERCENTAGE ATTAINING GRADES 1,2&3
Agriculture	M	155	81	52.3	49	83.9	Electronic	M	761	566	74.4	144	93.3
Science	F	196	133	67.9	43	89.8	Doc. Prep &	F	1957	1475	75.4	396	95.6
(Double Award)	T	351	214	61.0	92	87.2	Management	T	2718	2041	75.1	540	95.0
Agriculture	M	840	430	51.2	278	84.3	Electrical &	M	1744	590	33.8	537	64.6
Science	F	1359	721	53.1	471	87.7	Electronic	F	87	31	35.6	27	66.7
(Single Award)	T	2199	1151	52.3	749	86.4	Technology	T	1831	621	33.9	564	64.7
Biology	M	1634	707	43.3	607	80.4	English	M	14999	2497	16.6	3206	38.0
	F	3273	1378	42.1	1122	76.4	Language	F	24951	5720	22.9	5958	46.8
	T	4907	2085	42.5	1729	77.7		T	39950	8217	20.6	9164	43.5
Building	M	581	458	78.8	49	87.3	English	M	2165	473	21.8	396	40.1
Technology	F	66	57	86.4	3	90.9	Literature	F	5461	1927	35.3	1045	54.4
Construction	T	647	515	79.6	52	87.6		T	7626	2400	31.5	1441	50.4
Building	M	737	211	28.6	182	53.3	Food	M	722	248	34.3	303	76.3
Technology	F	47	19	40.4	11	63.8	& Nutrition	F	3874	1714	44.2	1588	85.2
Woods	T	784	230	29.3	193	54.0		T	4596	1962	42.7	1891	83.8
Caribbean	M	1827	484	26.5	736	66.8	French	M	255	71	27.8	92	63.9
History	F	3865	1294	33.5	1444	70.8		F	496	198	39.9	167	73.6
	T	5692	1778	31.2	2180	69.5		T	751	269	35.8	259	70.3
Chemistry	M	1926	551	28.6	710	65.5	Geography	M	2145	500	23.3	820	61.5
	F	2774	766	27.6	1068	66.1		F	2019	579	28.7	768	66.7
	T	4700	1317	28.0	1778	65.9		T	4164	1079	25.9	1588	64.0
Clothing	M	76	15	19.7	33	63.2	Home Econ.	M	369	132	35.8	157	78.3
& Textiles	F	1352	447	33.1	599	77.4	Management	F	2861	1258	44.0	1121	83.2
	T	1428	462	32.4	632	76.6		T	3230	1390	43.0	1278	82.6
Economics	M	212	52	24.5	94	68.9	Human	M	3300	1032	31.3	1098	64.5
	F	363	102	28.1	149	69.1	Social	F	9543	3275	34.3	3212	68.0
	T	575	154	26.8	243	69.0	Biology	T	12843	4307	33.5	4310	67.1

SOURCE: Caribbean Examinations Council

TABLE 4 - 5 (i)

**CARIBBEAN SECONDARY EDUCATION CERTIFICATE: TOTAL NUMBER OF CANDIDATES SITTING
& PERCENTAGE ATTAINING GRADES 1, 2 & 3 AT THE GENERAL PROFICIENCY LEVEL
BY SEX
2007/2008**

SUBJECT (cont'd)	SEX	NUMBER SITTING	NUMBER ATTAINING GRADES 1&2	PERCENTAGE ATTAINING GRADES 1&2	NUMBER ATTAINING GRADE 3	PERCENTAGE ATTAINING GRADES 1,2&3	SUBJECT (cont'd)	SEX	NUMBER SITTING	NUMBER ATTAINING GRADES 1&2	PERCENTAGE ATTAINING GRADES 1&2	NUMBER ATTAINING GRADE 3	PERCENTAGE ATTAINING GRADES 1,2&3
Information Technology*	M	5040	2769	54.9	1119	77.1	Principles of Business	M	4387	1827	41.6	1638	79.0
	F	7120	4069	57.1	1583	79.4		F	9360	4139	44.2	3336	79.9
	T	12160	6838	56.2	2702	78.5		T	13747	5966	43.4	4974	79.6
Integrated Science (Single Award)	M	2401	822	34.2	1172	83.0	Religious Education	M	925	336	36.3	367	76.0
	F	3509	1036	29.5	1903	83.8		F	1888	921	48.8	677	84.6
	T	5910	1858	31.4	3075	83.5		T	2813	1257	44.7	1044	81.8
Mathematics	M	13684	2394	17.5	3195	40.8	Social Studies	M	6885	1223	17.8	2828	58.8
	F	23456	3098	13.2	5126	35.1		F	12892	3368	26.1	5422	68.2
	T	37140	5492	14.8	8321	37.2		T	19777	4591	23.2	8250	64.9
Mech. Eng. Tech	M	914	388	42.5	209	65.3	Spanish	M	1109	436	39.3	336	69.6
	F	22	6	27.3	4	45.5		F	3093	1329	43.0	904	72.2
	T	936	394	42.1	213	64.9		T	4202	1765	42.0	1240	71.5
Music	M	49	10	20.4	21	63.3	Technical Drawing	M	2792	977	35.0	868	66.1
	F	99	18	18.2	50	68.7		F	325	134	41.2	99	71.7
	T	148	28	18.9	71	66.9		T	3117	1111	35.6	967	66.7
Office Administration	M	1751	683	39.0	741	81.3	Typewriting	M	2	0	0.0	0	0.0
	F	4905	2221	45.3	1951	85.1		F	4	0	0.0	0	0.0
	T	6656	2904	43.6	2692	84.1		T	6	0	0.0	0	0.0
Physical Education & Sports	M	603	521	86.4	59	96.2	Theatre Arts	M	32	8	25.0	16	75.0
	F	523	454	86.8	59	98.1		F	67	29	43.3	15	65.7
	T	1126	975	86.6	118	97.1		T	99	37	37.4	31	68.7
Physics	M	2477	993	40.1	842	74.1	Visual Arts	M	1093	280	25.6	568	77.6
	F	1902	923	48.5	652	82.8		F	859	207	24.1	430	74.2
	T	4379	1916	43.8	1494	77.9		T	1952	487	24.9	998	76.1
Principles of Accounts	M	3326	1059	31.8	975	61.2							
	F	7470	2785	37.3	2245	67.3							
	T	10796	3844	35.6	3220	65.4							

* combined General and Technical proficiencies

SOURCE: Caribbean Examinations Council

TABLE 4 - 6

**CARIBBEAN SECONDARY EDUCATION CERTIFICATE: TOTAL NUMBER OF CANDIDATES SITTING
& PERCENTAGE ATTAINING GRADES 1, 2 & 3 AT THE BASIC PROFICIENCY LEVEL
BY SEX
2007/2008**

SUBJECT	SEX	NUMBER SITTING	NUMBER ATTAINING GRADES 1&2	PERCENTAGE ATTAINING GRADES 1&2	NUMBER ATTAINING GRADE 3	PERCENTAGE ATTAINING GRADES 1,2&3 ¹
English Language	M	172	6	3.5	18	14.0
	F	137	12	8.8	15	19.7
	T	309	18	5.8	33	16.5
Mathematics	M	226	7	3.1	43	22.1
	F	326	22	6.7	50	22.1
	T	552	29	5.3	93	22.1
Social Studies	M	19	0	0.0	3	15.8
	F	29	1	3.4	5	20.7
	T	48	1	2.1	8	18.8

SOURCE: Caribbean Examinations Council

Table 4-7

**G.C.E. Advanced Level and Advanced Subsidiary Level
Number of Public School Candidates Sitting Percentage attaining Grades A-E and Grades a - e
2007 - 2008**

Subject	Number Sitting	Number Attaining Grades A - E	Number Attaining *Grades a - e	Percentage Attaining Grades A - E	Percentage Attaining *Grades a - e
Accounting	-	-	-	-	-
Art & Design	29	9	9	31.0	31.0
Biology	60	20	12	33.3	20.0
Business Studies	-	-	-	-	-
Chemistry	51	10	4	19.6	7.8
Economics	-	-	-	-	-
Law	-	-	-	-	-
Literatures in English	-	-	-	-	-
Mathematics	52	8	8	15.4	15.4
Physics	26	11	-	42.3	-
Psychology	54	20	19	37.0	35.2
Sociology	-	-	-	-	-

* GCE Advanced Subsidiary Level

Table 4-8

**G.C.E. Advanced Level and Advanced Subsidiary Level
Number of Private Candidates Sitting Percentage attaining Grades A-E and Grades a - e
2007 - 2008**

Subject	Number Sitting	Number Attaining Grades A - E	Number Attaining *Grades a - e	Percentage Attaining Grades A - E	Percentage Attaining *Grades a - e
Accounting	24	8	1	33.3	4.2
Art & Design	5	1	3	20.0	60.0
Biology	50	17	7	34.0	14.0
Business Studies	30	6	2	20.0	6.7
Chemistry	55	16	9	29.1	16.4
Economics	22	7	1	31.8	4.5
Law	37	6	1	16.2	2.7
Literatures in English	19	18	-	94.7	-
Mathematics	43	9	8	20.9	18.6
Physics	5	1	-	20.0	-
Psychology	229	40	51	17.5	22.3
Sociology	30	5	4	16.7	13.3

* GCE Advanced Subsidiary Level

TABLE 4 - 9

G.C.E. Advanced Level and Advanced Subsidiary Level
Total Number of Candidates Sitting Percentage attaining Grades A-E and Grades a - e
2007 - 2008

Subject	Number Sitting	Number Attaining Grades A - E	Number Attaining *Grades a - e	Percentage Attaining Grades A - E	Percentage Attaining *Grades a - e
Accounting	24	8	1	33.3	4.2
Art & Design	34	10	12	29.4	35.3
Biology	110	37	19	33.6	17.3
Business Studies	30	6	2	20.0	6.7
Chemistry	106	26	13	24.5	12.3
Economics	22	7	1	31.8	4.5
Law	37	6	1	16.2	2.7
Literatures in English	19	18	-	94.7	-
Mathematics	95	17	16	17.9	16.8
Physics	31	12	-	38.7	-
Psychology	283	60	70	21.2	24.7
Sociology	30	5	4	16.7	13.3

* GCE Advanced Subsidiary Level

Table 4-10 (i)

Caribbean Advanced Proficiency Examinations (CAPE)
Total Number of Candidates Sitting and Percentage attaining Grades 1-5 Unit 1
2007/2008

SUBJECT	SEX	NUMBER SITTING	NUMBER ATTAINING GRADES 1-5	PERCENTAGE ATTAINING GRADES 1-5	SUBJECT	SEX	NUMBER SITTING	NUMBER ATTAINING GRADES 1-5	PERCENTAGE ATTAINING GRADES 1-5
Accounting	M	270	235	87.0	French	M	13	13	100.0
	F	580	534	92.1		F	42	38	90.5
	T	850	769	90.5		T	55	51	92.7
Applied Mathematics	M	61	50	82.0	Geography	M	168	142	84.5
	F	99	87	87.9		F	164	146	89.0
	T	160	137	85.6		T	332	288	86.7
Art and Design	M	32	32	100.0	Geometrical and Mechanical Engineering Drawing	M	224	161	71.9
	F	41	41	100.0		F	21	16	76.2
	T	73	73	100.0		T	245	177	72.2
Biology	M	472	440	93.2	History	M	273	223	81.7
	F	936	871	93.1		F	822	714	86.9
	T	1408	1311	93.1		T	1095	937	85.6
Caribbean Studies	M	1384	1333	96.3	Information Technology	M	161	161	100.0
	F	2369	2349	99.2		F	199	197	99.0
	T	3753	3682	98.1		T	360	358	99.4
Chemistry	M	455	398	87.5	Law	M	106	73	68.9
	F	766	670	87.5		F	349	242	69.3
	T	1221	1068	87.5		T	455	315	69.2
Communication Studies	M	1788	1698	95.0	Literatures in English	M	185	161	87.0
	F	3105	3045	98.1		F	796	750	94.2
	T	4893	4743	96.9		T	981	911	92.9
Computer Science	M	373	373	100.0	Management of Business	M	617	474	76.8
	F	227	225	99.1		F	958	777	81.1
	T	600	598	99.7		T	1575	1251	79.4
Economics	M	373	335	89.8	Pure Mathematics	M	951	533	56.0
	F	557	515	92.5		F	1058	715	67.6
	T	930	850	91.4		T	2009	1248	62.1
Electrical and Electronic Technology	M	74	47	63.5	Physics	M	489	414	84.7
	F	2	2	100.0		F	312	284	91.0
	T	76	49	64.5		T	801	698	87.1
Environmental Science	M	75	67	89.3	Sociology	M	649	562	86.6
	F	169	163	96.4		F	1584	1484	93.7
	T	244	230	94.3		T	2233	2046	91.6
Food and Nutrition	M	25	22	88.0	Spanish	M	83	68	81.9
	F	175	171	97.7		F	241	215	89.2
	T	200	193	96.5		T	324	283	87.3

Table 4-10 (ii)

Caribbean Advanced Proficiency Examinations (CAPE)
Total Number of Candidates Sitting and Percentage attaining Grades 1-5 Unit 2
2007/2008

SUBJECT	SEX	NUMBER SITTING	NUMBER ATTAINING GRADES 1-5	PERCENTAGE ATTAINING GRADES 1-5	SUBJECT	SEX	NUMBER SITTING	NUMBER ATTAINING GRADES 1-5	PERCENTAGE ATTAINING GRADES 1-5
Accounting	M	369	328	88.9	French	M	12	12	100.0
	F	719	647	90.0		F	60	59	98.3
	T	1088	975	89.6		T	72	71	98.6
Applied Mathematics	M	4	4	100.0	Geography	M	184	118	64.1
	F	0	0	0.0		F	163	127	77.9
	T	4	4	100.0		T	347	245	70.6
Art and Design	M	32	32	100.0	Geometrical and Mechanical Engineering Drawing	M	100	84	84.0
	F	28	28	100.0		F	12	11	91.7
	T	60	60	100.0		T	112	95	84.8
Biology	M	338	321	95.0	History	M	221	193	87.3
	F	733	693	94.5		F	690	616	89.3
	T	1071	1014	94.7		T	911	809	88.8
Caribbean Studies	M	0	0	0.0	Information Technology	M	0	0	0.0
	F	0	0	0.0		F	0	0	0.0
	T	0	0	0.0		T	0	0	0.0
Chemistry	M	334	293	87.7	Law	M	90	50	55.6
	F	619	552	89.2		F	284	205	72.2
	T	953	845	88.7		T	374	255	68.2
Communication Studies	M	0	0	0.0	Literatures in English	M	127	115	90.6
	F	0	0	0.0		F	631	610	96.7
	T	0	0	0.0		T	758	725	95.6
Computer Science	M	233	229	98.3	Management of Business	M	496	466	94.0
	F	197	195	99.0		F	936	898	95.9
	T	430	424	98.6		T	1432	1364	95.3
Economics	M	319	216	67.7	Pure Mathematics	M	431	305	70.8
	F	529	387	73.2		F	547	450	82.3
	T	848	603	71.1		T	978	755	77.2
Electrical and Electronic Technology	M	3	3	100.0	Physics	M	366	325	88.8
	F	2	2	100.0		F	274	255	93.1
	T	5	5	100.0		T	640	580	90.6
Environmental Science	M	66	62	93.9	Sociology	M	440	410	93.2
	F	127	122	96.1		F	1217	1191	97.9
	T	193	184	95.3		T	1657	1601	96.6
Food and Nutrition	M	4	4	100.0	Spanish	M	39	34	87.2
	F	101	100	99.0		F	186	182	97.8
	T	105	104	99.0		T	225	216	96.0

TABLE 4 - 11

**UNIVERSITY OF TECHNOLOGY
GRADUATES AWARDED DEGREES, DIPLOMAS, CERTIFICATES BY
DEPARTMENT & SEX
2007/2008**

FACULTY	GRAND TOTAL			POSTGRADUATE DIPLOMA			DEGREE									DIPLOMA			CERTIFICATE		
	M	F	T	M	F	T	MASTERS			BACHELORS			ASSOCIATE			M	F	T	M	F	T
							M	F	T	M	F	T	M	F	T						
BUILT ENVIRONMENT	190	80	270	-	-	-	4	1	5	100	60	160	-	-	-	55	13	68	31	6	37
BUSINESS & MANAGEMENT	145	437	582	-	-	-	-	-	-	140	392	532	-	-	-	-	-	-	5	45	50
ENGINEERING & COMPUTING	371	107	478	-	-	-	-	-	-	211	82	293	9	2	11	126	14	140	25	9	34
HEALTH & APPLIED SCIENCE	35	176	211	-	-	-	-	-	-	26	134	160	3	25	28	1	9	10	5	8	13
EDUCATION & LIBERAL STUDIES	111	245	356	4	10	14	5	15	20	83	200	283	-	-	-	7	13	20	12	7	19
GRAND TOTAL	852	1045	1897	4	10	14	9	16	25	560	868	1428	12	27	39	189	49	238	78	75	153

Source: University of Technology, April 2009

TABLE 4-12

**JAMAICAN STUDENTS AWARDED FIRST AND HIGHER DEGREES
AT THE UNIVERSITY OF THE WEST INDIES, BY CAMPUS
BY FACULTY & SEX
2007/2008**

FACULTY/ DEPARTMENT	FIRST DEGREES									HIGHER DEGREES								
	CAMPUSES						TOTAL			CAMPUSES						TOTAL		
	CAVE HILL		MONA		ST. AUGUSTINE					CAVE HILL		MONA		ST. AUGUSTINE				
	M	F	M	F	M	F	M	F	T	M	F	M	F	M	F	M	F	T
Humanities	0	0	83	340	0	1	83	341	424	0	0	9	45	0	0	9	45	54
Social Sciences	0	0	213	794	0	1	213	795	1008	0	0	134	242	1	0	135	242	377
Law	0	0	0	0	0	0	0	0	0	0	0	0	0	0	0	0	0	0
Education	0	0	38	278	0	0	38	278	316	0	0	20	57	1	0	21	57	78
Gender Studies	0	0	0	0	0	0	0	0	0	0	0	1	3	0	0	1	3	4
Pure & Applied Sciences	0	0	127	158	0	2	127	160	287	0	0	24	19	0	0	24	19	43
Engineering	0	0	0	0	13	3	13	3	16	0	0	0	0	2	4	2	4	6
Agriculture	0	0	0	0	1	3	1	3	4	0	0	0	0	0	0	0	0	0
Medical Sciences	0	0	31	277	0	2	31	279	310	0	0	16	64	1	0	17	64	81
Total	0	0	492	1847	14	12	506	1859	2365	0	0	204	430	5	4	209	434	643

Source: University of the West Indies.

Note: Data for Cave Hill is not available at this time

TABLE 4-13

**JAMAICAN STUDENTS AWARDED CERTIFICATES AND DIPLOMAS
AT THE UNIVERSITY OF THE WEST INDIES, MONA CAMPUS
BY FACULTY & SEX
2007/2008**

FACULTY/ SCHOOL	CERTIFICATE			DIPLOMA			ADVANCED DIPLOMA			GRAND TOTAL		
	MALE	FEMALE	TOTAL	MALE	FEMALE	TOTAL	MALE	FEMALE	TOTAL	MALE	FEMALE	TOTAL
Humanities	0	0	0	1	1	2	0	0	0	1	1	2
Social Sciences	9	71	80	0	2	2	0	0	0	9	73	82
Education	0	0	0	0	0	0	2	18	20	2	18	20
Gender Studies	0	0	0	0	0	0	0	0	0	0	0	0
Pure & Applied	0	0	0	0	0	0	3	8	11	3	0	3
Total	9	71	80	1	3	4	5	26	31	15	100	115

Source: University of the West Indies.



FINANCIAL

STATISTICS

FINANCIAL STATISTICS 2008/2009

OVERVIEW

For the fiscal year ended March 31, 2009 \$65B was allocated to the Ministry of Education (MOE). This represented a 21 percent increase over the previous year. It accounted however for a slightly reduced fraction of the total national budget moving from 13.2% for the period 2007/ 2008 to 12.8 percent.

Recurrent Budget

The ministry's allotment for recurrent expenditure increased by 27 percent, moving from \$47.78B to \$60.75B. This was largely due to the increase in teacher's salaries and retroactive payments.

✍ Early Childhood Education

Early childhood education received an increased allotment of \$9M over the previous year, moving from \$2.136 billion to \$2.145 billion. The amount of money allocated to the Early Childhood Commission increased by \$74M while there was a slight reduction in the grants allocated to community/basic schools.

✍ Primary Education

The primary level received just over \$19M which accounted for 31 percent of the of the MOE's recurrent expenditure. The most significant increase was 26 percent which was for grants for instruction. This was due to the increase in teachers' salaries and subsequent retroactive payments.

✍ Secondary Education.

Secondary education accounted for 35 percent of the budget. Budgetary allocation increased from \$16.2B to \$21.2B. The main contributors to this increase were teachers' salaries and tuition fees for approximately 222,000 students.

✍ Tertiary Education.

The total allocation, for tertiary level education, increased by 25 percent. Of the \$12.6B, the University of the West Indies (UWI) received the largest portion, 60 percent, which accounted for 12.5 percent of the MOE's total recurrent expenditure. Some 44 percent more was spent on teacher education and training. Like the other levels of the system, most of the increase was to offset the additional cost of salaries.

Capital Budget

The national capital budget (Capital A and B) for the 2008/2009 period was \$198.5B of which the MOE received \$4.2B or 2.1 percent. This was 1.8 percent less than the previous period. When debt repayment was excluded, the ministry received 8 percent of the capital budget.

Capital A

Of the \$4.2B allocated to the MOE, locally funded projects (Capital A) amounted to \$2.93B. Approximately 91 percent of this amount was for the activities of the Education Transformation Project (ETP). Funds provided for maintenance of schools remained at \$1.02M for infant schools and increased by three percent at the primary level. Expenditure on secondary education fell significantly, by \$1.8B as the North Western Jamaica Schools project came to an end. At the tertiary level expenditure for Edna Manley College was reduced to 35 percent of the previous year's budget. Expenditure on teacher education and training through the Distance Education Project was reduced by 23 percent.

Capital B – Bilateral and Multilateral Projects

Early Childhood Education

❖ Enhancement of Basic Schools – Caribbean Development Bank (CDB)

This project aims at improving the quality of the learning environment at the Early Childhood level by renovating, constructing, furnishing and equipping basic schools resource centres and training early childhood practitioners. Some \$260M was allotted for this project for the financial year.

Primary Education

❖ Absenteeism in Jamaica's Primary School- International Development Bank (IDB)/ Japan Fund

The aim of the project is to determine the underlying causes of absenteeism in 100 primary schools and conduct interventions to effect improvement. \$9.3M was allocated to the project.

❖ Primary Education Support Project- IDB

For the year under review \$800m, or 73 percent more than the previous year was spent on the project, which aimed to improve access and quality at the primary level. The increased funds were to continue the works in progress of five primary schools.

❖ Expanding Education Horizons Project- United States Agency for International Development (USAID)

Some \$24.4M was spent on this project which aims to improve literacy and numeracy in targeted primary schools.

Secondary Education

- ❖ Reform of Secondary Education Project (Phase 2)- International Bank for Reconstruction and Development.(IBRD)
Rose II aims to improve quality and equity in secondary education through the creation of more places and the development of programmes to support the reform. The project was allocated \$209M.

Tertiary Education

- ❖ University of Technology Enhancement Project (CDB)
This project aims at increasing the university's capacity via the expansion and upgrading of facilities. \$22M was expended on the project.

Per Capita Expenditure (Unit Costs)

The recurrent per capita expenditure increased at all levels. The average amounts spent on a child at the primary and secondary levels were increased by 31 and 30 percent respectively. The early childhood level had the smallest increase of only 2 percent. The per capita expenditure for the primary level was \$80, 681, for the secondary level it was \$94, 755 and \$22,350 for early childhood.

Table 5-1

**MINISTRY OF EDUCATION IN THE NATIONAL BUDGET
(CURRENT PRICES) 2008/2009
REVISED ESTIMATES**

MINISTRIES:	RECURRENT		CAPITAL		TOTAL	
	J\$' 000	%	J\$' 000	%	J\$' 000	%
MINISTRY OF EDUCATION & YOUTH	60,750,000	19.63	4,259,161	2.1	65,009,161	12.8
HIS EXCELLENCY THE GOVERNOR GENERAL	113,248	0.04		0.0	113,248	0.0
HOUSES OF PARLIAMENT	650,973	0.21		0.0	650,973	0.1
OFFICE OF THE PUBLIC DEFENDER	61,877	0.02		0.0	61,877	0.0
OFFICE OF THE CONTRACTOR GENERAL	198,472	0.06		0.0	198,472	0.0
AUDITOR GENERAL	261,629	0.08		0.0	261,629	0.1
OFFICE OF THE SERVICES COMMISSIONS	141,136	0.05		0.0	141,136	0.0
OFFICE OF THE CHILDREN'S ADVOCATE	42,828	0.01		0.0	42,828	0.0
OFFICE OF THE PRIME MINISTER & DEPARTMENTS	5,174,521	1.67	3,275,763	1.7	8,450,284	1.7
OFFICE OF THE PRIME MINISTER(LOCAL GOVERNMENT)	6396367	2.07	4105405	2.1	10501772	2.1
OFFICE OF THE CABINET AND DEPT.	435,563	0.14	279,380	0.1	714,943	0.1
MINISTRY OF TOURISM	3,513,534	1.14	53,074	0.0	3,566,608	0.7
MINISTRY OF FINANCE AND PUBLIC SERVICE	149,224,538	48.22	162,733,690	82.0	311,958,228	61.4
MINISTRY OF NATIONAL SECURITY	34,599,487	11.18	2,807,276	1.4	37,406,763	7.4
MINISTRY OF JUSTICE	3,258,407	1.05	299,682	0.2	3,558,089	0.7
MINISTRY OF FOREIGN AFFAIRS & FOREIGN TRADE	2,549,058	0.82	25,240	0.0	2,574,298	0.5
MINISTRY OF LABOUR & SOCIAL SECURITY	1,869,434	0.60	2,233,507	1.1	4,102,941	0.8
MINISTRY OF HEALTH	28,508,381	9.21	1,057,729	0.5	29,566,110	5.8
MINISTRY OF INFORMATION, CULTUR, YOUTH & SPORTS	2,769,070	0.89	322,259	0.2	3,091,329	0.6
MINISTRY OF AGRICULTURE & FISHERIES	2,997,420	0.97	3,135,536	1.6	6,132,956	1.2
MINISTRY OF INDUSTRY, INVESTMENT & COMMERCE	1,847,611	0.60	457,335	0.2	2,304,946	0.5
MINISTRY OF ENERGY & MINING	369,401	0.12	130,000	0.1	499,401	0.1
MINISTRY OF MINING & TELECOMMUNICATIONS	892,064	0.29	980,697	0.5	1,872,761	0.4
MINISTRY OF ENERGY & MINING TELECOMMUNICATIONS	24,667	0.01	3	1.5E-06	24,670	0.0
MINISTRY OF WATER & HOUSING	621,896	0.20	1708624	1	2,330,520	0
MINISTRY OF TRANSPORT & WORKS	2,192,833	0.71	10643293	5	12,836,126	3
TOTAL GOVERNMENT EXPENDITURE:	309,464,415	100	198,507,654	100	507,972,069	100.0

Source: Estimates of Expenditure for the year ending 31 March 2008

Table 5-1

**MINISTRY OF EDUCATION IN THE NATIONAL BUDGET
(CURRENT PRICES) 2007/2008
ACTUAL EXPENDITURE**

MINISTRIES:	RECURRENT		CAPITAL		TOTAL	
	J\$' 000	%	J\$' 000	%	J\$' 000	%
MINISTRY OF EDUCATION & YOUTH	47,784,160	18.8	5,822,876	3.9	53,607,036	13.2
HIS EXCELLENCY THE GOVERNOR GENERAL	102,152	0.0		0.0	102,152	
HOUSES OF PARLIAMENT	574,467	0.2		0.0	574,467	0.1
OFFICE OF THE PUBLIC DEFENDER	51,307	0.0		0.0	51,307	0.0
OFFICE OF THE CONTRACTOR GENERAL	159,650	0.1		0.0	159,650	0.0
AUDITOR GENERAL	227,539	0.1		0.0	227,539	0.1
OFFICE OF THE SERVICES COMMISSIONS	119,554	0.0		0.0	119,554	0.0
OFFICE OF THE CHILDREN'S ADVOCATE	32,557	0.0		0.0	32,557	0.0
OFFICE OF THE PRIME MINISTER & DEPARTMENTS	3,857,335	1.5	2,064,447	1.4	5,921,782	1.5
OFFICE OF THE PRIME MINISTER(LOCAL GOVERNMENT)	4063252	1.6	630810	0.4	4694062	1.2
OFFICE OF THE CABINET AND DEPT.	550,461	0.2	951,972	0.6	1,502,433	0.4
MINISTRY OF TOURISM	3,518,032	1.4	101,250	0.1	3,619,282	0.9
MINISTRY OF FINANCE AND PUBLIC SERVICE	125,260,573	49.2	115,612,179	76.7	240,872,752	59.4
MINISTRY OF NATIONAL SECURITY	28,912,575	11.4	2,273,430	1.5	31,186,005	7.7
MINISTRY OF JUSTICE	2,501,730	1.0	277,762	0.2	2,779,492	0.7
MINISTRY OF FOREIGN AFFAIRS & FOREIGN TRADE	2,273,814	0.9	58,740	0.0	2,332,554	0.6
MINISTRY OF LABOUR & SOCIAL SECURITY	1,482,388	0.6	2,680,214	1.8	4,162,602	1.0
MINISTRY OF HEALTH	22,886,227	9.0	1,004,716	0.7	23,890,943	5.9
MINISTRY OF INFORMATION, CULTURE, YOUTH & SPORTS	1,014,181	0.4	312,271	0.2	1,326,452	0.3
MINISTRY OF AGRICULTURE & FISHERIES	2,611,243	1.0	2,034,909	1.4	4,646,152	1.1
MINISTRY OF INDUSTRY, TECHNOLOGY, AND COMMERCE	602,140	0.2	72,197	0.0	674,337	0.2
MINISTRY OF INDUSTRY, INVESTMENT & COMMERCE	699,065	0.3	582,400	0.4	1,281,465	0.3
MINISTRY OF ENERGY, MINING AND TELECOMMUNICATIONS	209,879	0.1	40,071	0.0	249,950	0.1
MINISTRY OF WATER AND HOUSING	264,001	0.1	1333973	0.9	1,597,974	0.4
MINISTRY OF TRANSPORT AND WORKS	1,219,314	0.5	10097076	6.7	11,316,390	2.8
MINISTRY OF HOUSING, TRANSPORT, WATER & WORKS	550,782	0.2	4527817	3.0	5,078,599	1.3
MINISTRY OF LOCAL GOVERNMENT AND ENVIRONMENT	3,174,916	1.2	202765	0.1	3,377,681	0.8
TOTAL GOVERNMENT EXPENDITURE:	254,703,294	100	150,681,875	100	405,385,169	100.0

Source: Estimates of Expenditure for the year ending 31 March 2008

Table 5 - 2(a)

**MINISTRY OF EDUCATION
RECURRENT BUDGET (2007/2008-2008/2009)
CURRENT PRICES J\$' 000**

	2007/2008	2008/2009
	Revised Estimates	Revised Estimates
CENTRAL ADMINISTRATION AND SUPPORT SERVICES:		
Executive Direction and Administration	712,703	1,164,387
Training	5,637	6,698
Regional & International Cooperation	15,867	3,571
Social and Economic Support Programme	10,706	14,316
Regional Direction and Administration	223,182	321,192
TOTAL CENTRAL ADMINISTRATION AND SUPPORT SERVICES	968,095	1,510,164
EARLY CHILDHOOD EDUCATION:		
Supervision	151,931	194,808
BASIC SCHOOLS		
Grants for Community schools	1,280,762	1,156,800
The Early Childhood Commission	106,380	180,261
INFANT SCHOOLS		
Grants for Direction and Administration	104,920	110,417
Grants for Instruction	456,946	453,694
Grants for Maintenance of Buildings and Equipment	3,240	3,240
School Feeding Programme	20,642	33,192
Grants for Day Care Centres	11,066	12,805
TOTAL EARLY CHILDHOOD EDUCATION	2,135,887	2,145,217

Table 5 - 2(a)

**MINISTRY OF EDUCATION
RECURRENT BUDGET (2007/2008-2008/2009)
CURRENT PRICES J\$' 000**

	2007/2008	2008/2009
	Revised Estimates	Revised Estimates
PRIMARY EDUCATION:		
Supervision	123,044	155,749
School Feeding Programme	846,339	1,360,883
PRIMARY SCHOOLS		
Grants for Direction and Administration	663,763	849,130
Grants for Instruction	6,554,792	9,109,933
Grants for Maintenance of Buildings and Equipment	37,082	40,287
TOTAL PRIMARY SCHOOLS	8,225,020	11,515,982
ALL AGE SCHOOLS		
Grants for Direction and Administration	547,605	549,576
Grants for Instruction	6,150,203	6,960,461
Grants for Maintenance of Buildings & Equipment	33,839	33,839
Other Grants	25,000	30,000
TOTAL ALL AGE SCHOOLS	6,756,647	7,573,876
TOTAL PRIMARY EDUCATION	14,981,667	19,089,858

Table 5 - 2(a)

**MINISTRY OF EDUCATION
RECURRENT BUDGET (2007/2008-2008/2009)
CURRENT PRICES J\$' 000**

	2007/2008	2008/2009
	Revised Estimates	Revised Estimates
SPECIAL EDUCATION:		
Administration and Supervision	19,737	22,964
Grants for Direction and Administration	187,771	224,077
Grants for Instruction	287,210	406,895
Grants for Maintenance of Buildings & Equipment	5,215	5,430
Grants for Boarding	4,156	4,160
NON-GOVERNMENT ORGANIZATIONS	46,800	52,000
MICO CARE CENTER	54,342	76,934
TOTAL SPECIAL EDUCATION	605,231	792,460
SECONDARY EDUCATION:		
Supervision	81,591	105,333
High Schools	13,820,259	17,612,585
Junior High Schools and Junior High Departments	493,783	1,019,410
GENERAL SECONDARY EDUCATION	14,395,633	18,737,328
TECHNICAL AND VOCATIONAL EDUCATION:		
School Supervision and Administration	39,191	78,609
Technical High Schools	1,474,662	1,963,507
Agricultural Schools	83,340	111,287
TOTAL TECHNICAL, VOCATIONAL AND AGRICULTURAL SECONDARY EDUCATION	1,597,193	2,153,403
School Feeding Programme	165,139	265,538
TOTAL SECONDARY EDUCATION	16,157,965	21,156,269

Table 5 - 2(a)

**MINISTRY OF EDUCATION
RECURRENT BUDGET (2007/2008-2008/2009)
CURRENT PRICES J\$' 000**

	2007/2008	2008/2009
	Revised Estimates	Revised Estimates
TERTIARY EDUCATION:		
Administration and Supervision	52,431	121,111
University Council of Jamaica	28,851	37,178
Council of Community Colleges of Jamaica	20,723	30,260
Distance Bachelor of Education (Bed.) Program for Secondary School Teachers	2,500	2,500
UNIVERSITIES		
Grants to the University of the West Indies	6,486,261	7,592,000
Scholarships and Tuition fees	33,330	40,958
Other Scholarships	2,500	3,200
Boarding Grants - U.W.I.	24,960	29,820
Grants to the University of Technology	1,261,965	1,603,403
TOTAL UNIVERSITIES	7,809,016	9,269,381
OTHER TERTIARY INSTITUTIONS		
Multi Disciplinary Colleges	890,471	1,349,791
Teachers' Education and Training	861,580	1,241,886
College of Agriculture, Science and Education	213,253	305,418
Edna Manley College of The Visual and Performing Arts	174,765	257,455
Training of Health Officials	28,688	21,420
TOTAL TERTIARY EDUCATION	10,082,278	12,636,400

Table 5 - 2(a)

**MINISTRY OF EDUCATION
RECURRENT BUDGET (2007/2008-2008/2009)
CURRENT PRICES J\$' 000**

	2007/2008	2008/2009
	Revised Estimates	Revised Estimates
ADULT EDUCATION	134,951	164,103
COMMON EDUCATIONAL SERVICES	1,265,381	1,651,605
LIBRARY SERVICES	742,393	885,539
TOTAL EDUCATIONAL EXPENDITURE	47,073,849	60,031,615
ARTS AND CULTURE	-	
YOUTH DEVELOPMENT SERVICES	710,311	718,385
GENERAL GOVERNMENT SERVICES: ELECTIONS		-
TOTAL RECURRENT EXPENDITURE	47,784,160	60,750,000

Footnote:

1. Formerly Ministry of Education and Youth

Source: Estimates of Expenditure for the year ending 31 March 2009

Table 5 - 2(b)

MINISTRY OF EDUCATION ¹
TOTAL CAPITAL BUDGET², (2007/2008-2008/2009)
(Current Prices - J\$' 000)

	2007/2008	2008/2009
	Revised Estimates	Revised Estimates
EARLY CHILDHOOD AND PRIMARY EDUCATION :		
Early Childhood Education:		
Basic Schools		
Community Schools	1,020	1,020
Enhancement of Basic Schools (CDB)	164,000	260,000
Jamaica Early Childhood Development (PHRD)	36,200	
Early Childhood Development Project (IBRD)		
Total	201,220	261,020
Primary Education		
Primary Schools	24,000	24,650
All Age Schools	-	
The Primary Education Improvement Project (PEIP) (IADB)	12,121	
Primary Education Support Project (IDB)	462,306	800,370
New Horizons for Primary Schools (USAID)	-	
Expanding Education Horizons Project (USAID)	27,120	24,400
Absenteeism in Jamaica's Primary School (IDB/Japan Fund)	7,580	9,290
Total	533,127	858,710
Special Education		
Repairs and Maintenance	2,300	7,200
TOTAL EARLY CHILDHOOD, PRIMARY & SPECIAL EDUCATION	736,647	1,126,930

Table 5 - 2(b)

MINISTRY OF EDUCATION ¹
TOTAL CAPITAL BUDGET², (2007/2008-2008/2009)
 (Current Prices - J\$' 000)

	2007/2008	2008/2009
	Estimates	Revised Estimates
SECONDARY EDUCATION:		
General Secondary Schools		
High Schools		
Repairs and Maintenance	8,000	8,100
Upgrading Programme	-	
North Western Jamaica Schools Project	1,753,874	
UDC/WICHON St Catherine Schools Project	-	
Reform of Secondary Education--ROSE (Phase 2) (IBRD)	206,200	209,000
Total:	1,968,074	217,100
Technical and Vocational Education:		
Technical High Schools	20,000	700
Agricultural Education		35,000
Total:	20,000	35,700
TOTAL SECONDARY EDUCATION:	1,988,074	252,800

Table 5 - 2(b)

MINISTRY OF EDUCATION ¹
TOTAL CAPITAL BUDGET², (2007/2008-2008/2009)
(Current Prices - J\$' 000)

	2007/2008	2008/2009
	Estimates	Revised Estimates
TERTIARY EDUCATION:		
Multi Disciplinary Colleges	100,374	35,000
Teachers' College		
Universirty of Technology Enhancement Project	-	22,000
Inservice Training for Teachers - Distance Education Project	63,740	49,224
TOTAL TERTIARY EDUCATION:	164,114	106,224
GENERAL ADMINISTRATIVE AND SUPPORT SERVICES:		
General Administration:		
Maintenance of Buildings and Equipment	10,000	34,372
Education Transformation	2,376,941	2,655,360
Social and Economic Support Programme	-	
Social Sector Development Project (IBRD)	-	
TOTAL GENERAL ADMINISTRATIVE AND SUPPORT SERVICES:	2,386,941	2,689,732

Table 5 - 2(b)

MINISTRY OF EDUCATION ¹
TOTAL CAPITAL BUDGET², (2007/2008-2008/2009)
 (Current Prices - J\$' 000)

	2007/2008	2008/2009
	Estimates	Revised Estimates
ADULT EDUCATION	-	
LIBRARY SERVICES	45,100	30,475
YOUTH DEVELOPMENT SERVICES	2,000	3,000
COMMON SERVICES:	-	
TOTAL EDUCATIONAL EXPENDITURE	5,322,876	4,209,161
ARTS AND CULTURE		
STUDENTS NUTRITION		
DISASTER MANAGEMENT	500,000	50,000
TOTAL CAPITAL BUDGET	5,822,876	4,259,161

Footnote:

1. Formerly Ministry of Education and Youth

2. The total capital budget combines the Capital A budget, which consists of locally funded projects, and Capital B, which consists of multilaterally and bilaterally funded projects.

CDB Caribbean Development Bank
IBRD: International Bank of Reconstruction and Development
IADB/IDB: Inter-American Development Bank
PHRD Population Human Resource Development Project
USAID: United States Agency for International Development

Table 5 - 3

MINISTRY OF EDUCATION ¹
PER CAPITA RECURRENT EXPENDITURE BY LEVEL
(2007/2008-2008/2009) (J\$ - Current Costs)

School Levels	2007/2008 Revised Estimates	2008/2009 Revised Estimates
Early Childhood :		
Basic	14,443	13,678
Infant	43,797	58,986
Average Early Childhood ²	19,521	19,887
Primary :		
Primary	36,700	49,989
Grades 1-6 of All Age, Primary & Junior High	80,818	101,850
Average Primary ²	53,258	69,571
Special Education	146,960	185,075
Secondary :		
Secondary High Schools	70,686	88,711
Technical High	72,402	94,032
Voc / Agricultural	267,544	321,871
Grades 7-9 of All Age, Primary & Junior High	14,888	32,213
Average Secondary Education ²	64,798	84,150

Table 5 - 3

MINISTRY OF EDUCATION ¹
PER CAPITA EXPENDITURE BY LEVEL
(2007/2008-2008/2009) (J\$ - Current Costs)

School Levels	2007/2008 Revised Estimates	2008/2009 Revised Estimates
Tertiary :		
University of the West Indies	589,744	688,867
University of Technology	135,317	167,742
Teachers' Colleges	98,151	141,738
Community Colleges	114,161	155,895
Edna Manley College of Visual & Performing Arts	380,475	555,059
College of Agriculture, Science and Education	241,441	350,250
Average Tertiary Education ²	278,002	332,331

Footnote:

1. Formerly Ministry of Education and Youth
2. Average per capita figure for each level includes administration and supervision as well as other costs which are difficult to subdivide among school types.

NB. Because of the difference between the financial and the school years, enrolment figures have been prorated to take this into account.