

These wagons were constructed between 1987 and 1989. They are internationally registered with the SNCF for use in mainland Europe only.

The wagons meet existing RIV / RID / UIC regulations and have been designed primarily for the conveyance of Hydrochloric Acid or other compatible chemical products.

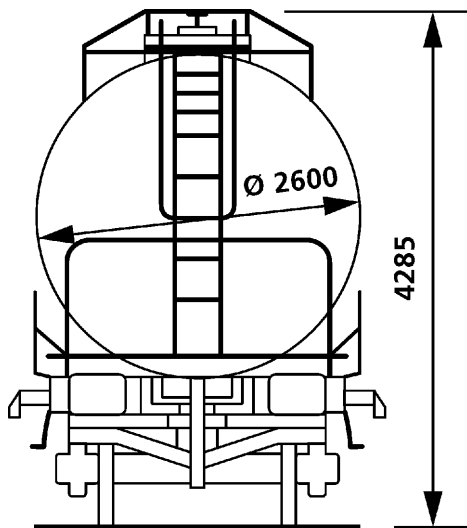
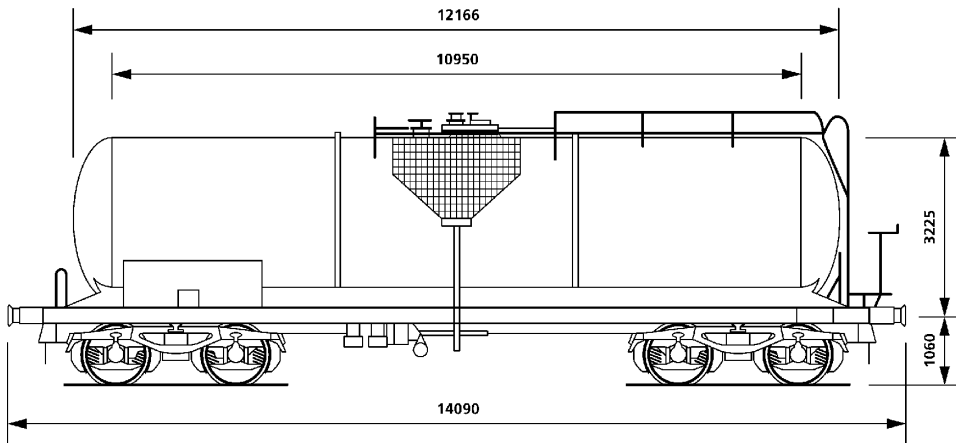

Wagon Data

<i>Overall length (over buffers)</i>	14.090mm
<i>Overall height</i>	4.285mm
<i>Tare weight</i>	23.200 kgs
<i>Payload (axle load 22.5 tonnes)</i>	66.800 kgs
<i>Minimum curve</i>	35 metres
<i>Maximum speed</i>	100 kph
<i>Maximum capacity</i>	60m3
<i>Barrel length</i>	12.166mm
<i>Barrel Lining material</i>	Ebonite
<i>Barrel pressure (Test)</i>	6.0 Bar
<i>Barrel pressure (Working)</i>	4.0 Bar

Payload	A	B1	B2	C	D
S	40.8	47.2	48.8	58.8	66.8
120	0.0				

GE301

Hydrochloric Acid Tank