

C-Major™ Consumer Audio

STEEBAC9460B Evaluation Board User's Guide

**(For the evaluation of STAC9460/61/62/63
audio codecs and DACs)**

Preliminary Version 1.0
12/6/01

2-9460-EB1-1.0-1201

Copyright © 2001 SigmaTel, Inc. All rights reserved.

All contents of this document are protected by copyright law and may not be reproduced without the express written consent of SigmaTel, Inc. SigmaTel, the SigmaTel logo, and combinations thereof are trademarks of SigmaTel, Inc. Other product names used in this publication are for identification purposes only and may be trademarks or registered trademarks of their respective companies. The contents of this document are provided in connection with SigmaTel, Inc. products. SigmaTel, Inc. has made best efforts to ensure that the information contained herein is accurate and reliable. However, SigmaTel, Inc. makes no warranties, express or implied, as to the accuracy or completeness of the contents of this publication and is providing this publication "AS IS". SigmaTel, Inc. reserves the right to make changes to specifications and product descriptions at any time without notice, and to discontinue or make changes to its products at any time without notice. SigmaTel, Inc. does not assume any liability arising out of the application or use of any product or circuit, and specifically disclaims any and all liability, including without limitation special, consequential, or incidental damages.



1. FEATURES

- 6-channel analog output with independent volume control
- Differential stereo analog input
- Dual microphone inputs with independent volume control
- Digital inputs (clock and data signals) can be provided by an external source, using standard I2S interface
- On-board, I2S clock generation
- SPDIF interface to digital audio signal sources (available soon)
- RS-232 serial interface to host computer with user-configurable baud rate

Device	DAC	ADC
STAC9460	6 DACs, 24 Bits	2 ADCs, 24 Bits
STAC9461	6 DACs, 24 Bits	N/A
STAC9462	2 DACs, 24 Bits	2 ADCs, 24 Bits
STAC9463	2 DACs, 24 Bits	N/A

Table 1. Product Comparison Table

2. DESCRIPTION

The STEEBAC9460B evaluation board (for evaluating D-Major consumer audio STAC9460/61/62/63 codecs and DACs) provides a flexible and convenient platform for evaluating the functionality and performance of the STAC9460/61/62/63; 24-bit, 192 kHz consumer audio codecs and DACs. With a full array of 6 channel analog outputs, differential and microphone inputs, and multiple options for standard I2S digital inputs, the STEEBAC9460B evaluation board interfaces easily to the majority of digital audio test equipment, providing convenient options for user application development.

Operation of the STEEBAC9460B Evaluation Board requires a minimal amount of external equipment:

- Analog/digital signal analyzer (Audio Precision Cascade SYS-2522 recommended)
- Digital signal source using standard I2S interface (Audio Precision SIA-2322 adapter recommended)
- PC with available COM port
- Power supply (7V minimum supply needed)
- Operation in Digital Loopback Mode is supported, but will be limited by the ADC dynamic range.

3. SYSTEM OVERVIEW

Note: The STEEBAC9460B evaluation board was designed for engineering evaluation and therefore includes stuffing options for circuits that would not be required in a typical consumer audio application. As a result, this board is not intended to serve as an example reference design, but rather a flexible evaluation vehicle.

Figure 1 illustrates the location of circuits and jumper settings for the STEEBAC9460B evaluation board.



C-Major™ Consumer Audio

STEEBAC9460B Evaluation Board User's Guide

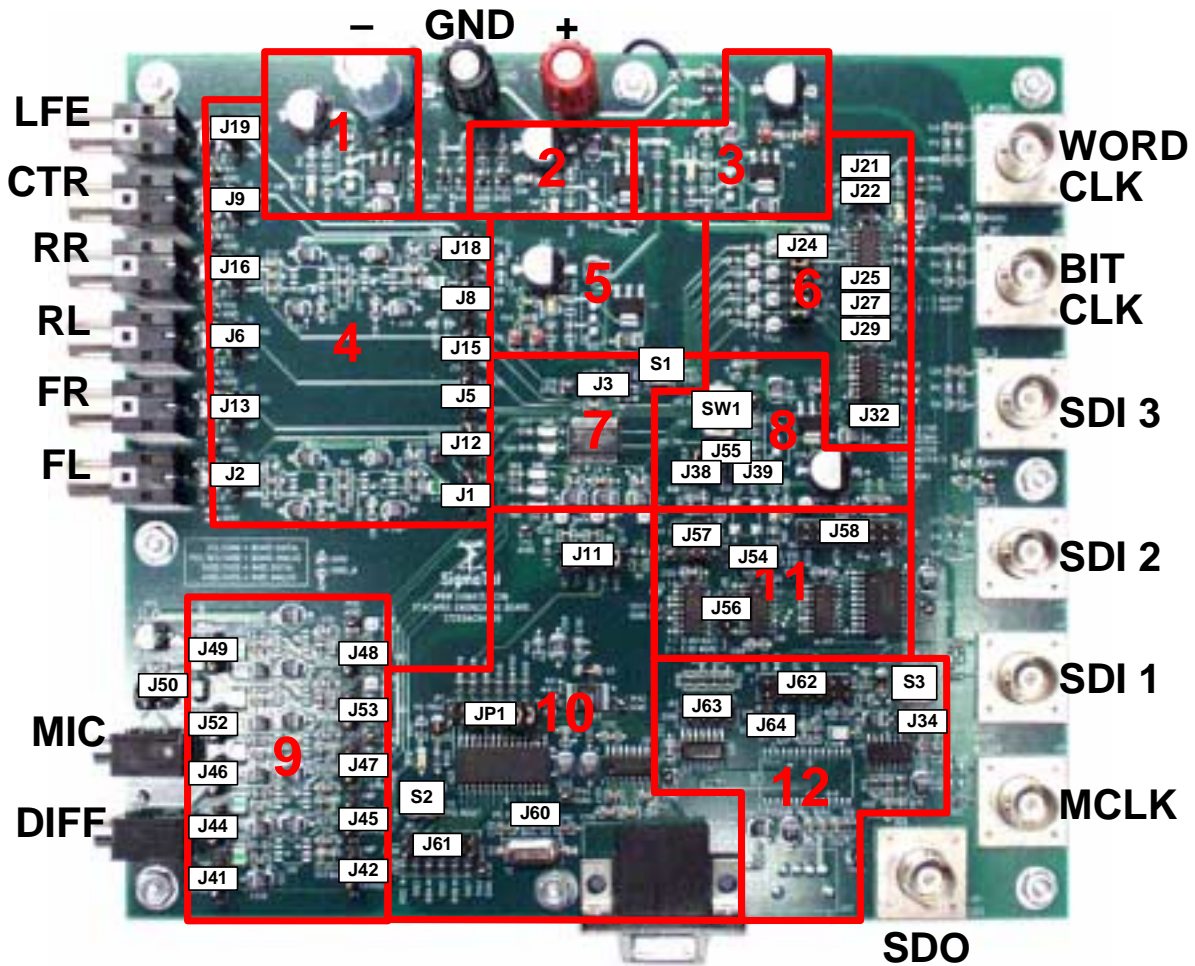

- | | |
|-------------------------------|-----------------------------------|
| 1 : OP AMP NEG. PWR | 7 : STAC9460 |
| 2 : BOARD ANALOG PWR | 8 : BOARD DIGITAL PWR* |
| 3 : CODEC DIGITAL PWR | 9 : ANALOG INPUT AMPLIFIERS* |
| 4 : ANALOG OUTPUT AMPLIFIERS* | 10 : I2C/RS232 TERMINAL INTERFACE |
| 5 : CODEC ANALOG PWR | 11 : CLK GENERATION* |
| 6 : DIGITAL INPUT BUFFERS* | 12 : SPDIF* |

* DENOTES OPTIONAL CIRCUITRY USED FOR EVALUATION/CHARACTERIZATION PURPOSES

Figure 1. STEEBAC9460B Evaluation Board



3.1. Analog I/O

6 analog outputs for front (left and right), surround (left and right), center, and LFE channels are provided through standard RCA connectors. The differential and microphone inputs are provided through standard stereo audio jacks. The microphone input is user-configurable for a biased, mono, or stereo microphone input. (See details on jumper settings for J50 in Table 7, “Description of Jumper/Switch Settings,” on page 7 below.)

3.2. Digital I/O and Clocks

3.2.1. External I2S Interface

The STEEBAC9460B evaluation board provides a convenient I2S interface through standard BNC connectors, which allows clock and data signals to be generated by an external source, such as an Audio Precision test system. To use the BNC inputs for I2S inputs, install jumpers as directed in Table 2, “Jumper Settings for BNC I2S Inputs”.

JUMPER	CONNECTIONS
J24	Install all jumpers
J58	Remove all jumpers
J62	Remove all jumpers

Table 2. Jumper settings for BNC I2S Inputs

3.2.2. I2S Clock Generation Module

In addition, the board includes a user-configurable clock generation circuit that provides I2S clock and master clock inputs to the STAC9460/61/62/63. To use the clock generation circuit, install jumpers as directed in Table 3, “Jumper Settings for CLK Generataion Circuit”.

JUMPER	CONNECTIONS
J24	Install all jumpers
J62	Remove all jumpers
J38	Install jumper
J54	Install jumper 1-2
J56	Install jumper 1-2 for 48 kHz WORD CLK or Install jumper 2-3 for 96 kHz WORD CLK
J58	Install 1-2 for 48 or 96 kHz WORD CLK Install 5-6 for 3.072 Mhz BIT CLK Install 9-10 for 24.5 Mhz MASTER CLK or Install 11-12 for 12.2 Mhz MASTER CLK Install 13-14 to enable BIT CLK

Table 3. Jumper settings for CLK Generation Circuit

Note: When using the CLK generation circuit, disconnect any BNC connectors providing clock signals.



3.2.3. SPDIF Input Interface

The STEEBAC9460B evaluation board also includes an audio receiver circuit which provides additional flexibility through a standard SPDIF input interface. To use this SPDIF receiver circuit for digital clock and data inputs, install jumpers as described in Table 4.

JUMPER	CONNECTIONS
J55	Install to provide power to receiver circuit
J39	Install to provide power to U4 inverter
J64	Do not install, leave open
J63	Install 1-2, 3-4, 7-8 to set the serial port mode configuration for the CS8414 digital audio receiver. Note: If all jumpers are unpopulated, the CS8414 is held in reset
J52	Install 1-2, 3-4, 5-6, 9-10 to provide SDI_1, WCLK, BIT CLK, and MCLK, respectively, to the STAC9460/61/62/63
J58	Do not install any jumpers This is necessary to prevent any interference from clock signals sourced by the clock generation circuit

Table 4. Jumper settings for SPDIF Receiver Circuit

3.3. Power supply

Power is provided to the STEEBAC9460B evaluation board through three binding posts: GND, +7V, -7V. The +7V supply is separated and regulated down to 5V to provide isolated supply sources to digital and analog circuits on the board. The -7V supply is optional and used only when needed to provide a negative supply to the amplifiers that can be used to boost the analog I/O signals.

4. SERIAL CONTROL PORT (RS-232 INTERFACE)

Configuration and control of the STAC9460/61/62/63 processor on the evaluation board is accomplished through an RS-232 serial connection. A terminal program, such as HyperTerminal or TeraTerm, should be used to communicate over this interface. Jumper settings (JP1) on the board determine the baud rate for the serial connection (see Table 5 for details). Note: The default setting is 1200 baud.

J 1-2	J3-4	J5-6	Baud Rate
ON	ON	ON	1200*
OFF	ON	ON	2400
ON	OFF	ON	4800
OFF	OFF	ON	9600
ON	ON	OFF	19200
OFF	ON	OFF	38400
ON	OFF	OFF	76800
OFF	OFF	OFF	115200

Table 5. RS-232 Serial Interface Baud Rate Jumper Settings (JP1)



The terminal program should be configured with the settings shown in Table 6.

Parameter	Value
Baud rate	1200 (default)
Data	8
Parity	None
Stop Bits	1
Flow Control	Off

Table 6. Terminal Program Configuration

Several functions are available within the serial interface software for configuration and control of the STAC9460/61/62/63:

“**A**”: prints the I2C slave device address used by the PIC16F876 to address the STAC9460/61/62/63.

“**D**”: dumps the contents of registers 0-A, C, E-14 to the screen. (Registers B and D are not printed because they are reserved.)

“**Rxx**”: reads the value of register xx and prints it out to the screen.

“**Wxxyy**”: writes value yy into register xx.

STAC9460/61/62/63 register configuration scripts are provided on the CD-ROM included with this evaluation board. These scripts can be used in conjunction with the terminal program to automatically configure the STAC9460/61/62/63 for performance evaluation of the DAC or ADC.

In a typical terminal program, a configuration script can be run automatically by executing a “Send file” or “Transfer file”, creating a fast and convenient method for configuring the STAC9460/61/62/63. For example, if using HyperTerminal, execute Transfer, Send Text File, and then choose the desired STAC9460/61/62/63 configuration script. This will execute all register writes contained within the chosen configuration script.

See Section 6, Recommended Test Procedures, for details on the STAC9460/61/62/63 configuration scripts.



5. JUMPER AND SWITCH SETTINGS

(Please refer to the STEEBAC9460B evaluation Board schematics for further details on jumper and switch functionality.)

Jumper	Purpose	Position	Function Selected
JP1	General I2C control	1-2, 3-4, 5-6	Select baud rate for serial interface, see Table 1.0 for details
		7-8	Enable keyboard echo; default is OFF
		9-10	Determines I2C slave address: OFF: addr. = 0x54 ON* addr. = 0x56
		11-12	Not used
		13-14	For PIC16F876 prog. only; <i>Must remain OFF</i>
J1, J2	Analog output amp. option	1-2	Amplify front left channel
		2-3*	Bypass amp.
J5, J6	Analog output amp. option	1-2	Amplify front right channel
		2-3*	Bypass amp.
J8, J9	Analog output amp. option	1-2	Amplify center channel
		2-3*	Bypass amp.
J12, J13	Analog output amp. option	1-2	Amplify front right channel
		2-3*	Bypass amp.
J15, J16	Analog output amp. option	1-2	Amplify rear right channel
		2-3*	Bypass amp.
J18, J19	Analog output amp. option	1-2	Amplify LFE channel
		2-3*	Bypass amp.
J3	PIC16F876 reset	OFF*	If On, S2 provides STAC9460/61/62/63 reset simultaneous with PIC reset
J11	I2C control	1-2*	CS high, I2C slave address = 56
		3-4	CS controlled by I2C master
		5-6	CS low, I2C slave address = 54
J21	LR_WORD buffer/invert option	1-2*	Buffer LR_WORD
		3-4	Invert LR_WORD
J22	SC_BIT buffer/invert option	1-2*	Buffer SC_BIT
		3-4	Invert SC_BIT
J24	Signal pass-through for digital I/O	All ON*	<i>Must remain ON.</i>
J25	SDI_3 buffer/invert option	1-2*	Buffer SDI_3
		3-4	Invert SDI_3
J27	SDI_2 buffer/invert option	1-2*	Buffer SDI_2
		3-4	Invert SDI_2
J29	SDI_1 buffer/invert option	1-2*	Buffer SDI_1
		3-4	Invert SDI_1
J32	MCLK buffer/invert option	1-2*	Buffer MCLK
		3-4	Invert MCLK
J34	SDO buffer/invert option	1-2*	Buffer SDO
		3-4	Invert SDO
J38	VCC CLK power source	ON*	Provides power to clk gen circuit
J39	SDO Buffer power source	ON*	Provides power to SDO buffer

Table 7. Description of Jumper/Switch Settings



Jumper	Purpose	Position	Function Selected
J41, J42	Differential input amp. option	1-2* 3-4	Bypass amp. Amplify diff. right channel
J44, J45	Differential input amp. option	1-2* 3-4	Bypass amp. Amplify diff. left channel
J46, 47	Differential input amp. option	1-2* 3-4	Bypass amp. Amplify diff. GND
J48, J49	Mic input amp. option	1-2* 3-4	Bypass amp. Amplify mic right channel
J52, J53	Mic input amp. option	1-2* 3-4	Bypass amp. Amplify mic left channel
J50	Mic input config. options	1-3 3-4* 4-6	Provide mic bias Stereo mic Mono mic
J54	Clock input select for CLK gen. circuit	1-2* 3-4	On-board OSC External CLK input
J55	SPDIF power source	OFF*	Provides power to SPDIF circuit
J56	Set value of WORD CLK from CLK. generation circuit	1-2* 3-4	48 kHz WORD CLK 96 kHz WORD CLK
J57	External CLK input for CLK gen. circuit	OFF	Option to provide external clk source to replace on-board 49 Mhz oscillator
J58	Passes thru signals from CLK generation circuit	1-2* 5-6* 9-10* 11-12 13-14*	48 or 96 kHz WORD CLK 3.072 Mhz BIT CLK 24.5 Mhz MASTER CLK 12.2 Mhz MASTER CLK Enable BIT CLK
J60	SigmaTel internal eval. only	N/A	N/A
J61	SigmaTel internal eval. only	OFF*	Must remain OFF
J62, J63, J64	SigmaTel internal eval. only	N/A	
S1	STAC9460/61/62/63 reset	N/A	Toggle provides soft reset
S2	PIC16F876 reset	N/A	Toggle provides soft reset
SW1	PIC16F876 power	ON*	Enables power supply to PIC16F876

Table 7. Description of Jumper/Switch Settings (Continued)

Note: * Denotes default jumper/switch setting



6. RECOMMENDED TEST PROCEDURES

The CD-ROM included with the STEEBAC9460B evaluation board provides standard Audio Precision test procedures and STAC9460/61/62/63 configuration scripts for use in basic ADC and DAC performance measurements.

Figures 2 and 3 illustrate the recommended Audio Precision to STEEBAC9460B evaluation Board connections, and the recommended switch settings for the transmitter module of the SIA-2322, respectively.

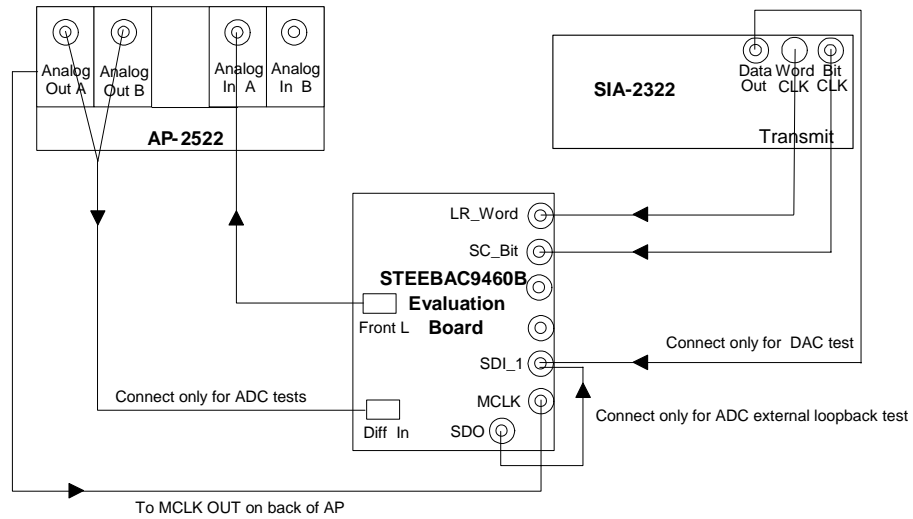

Figure 2. Audio Precision Connections

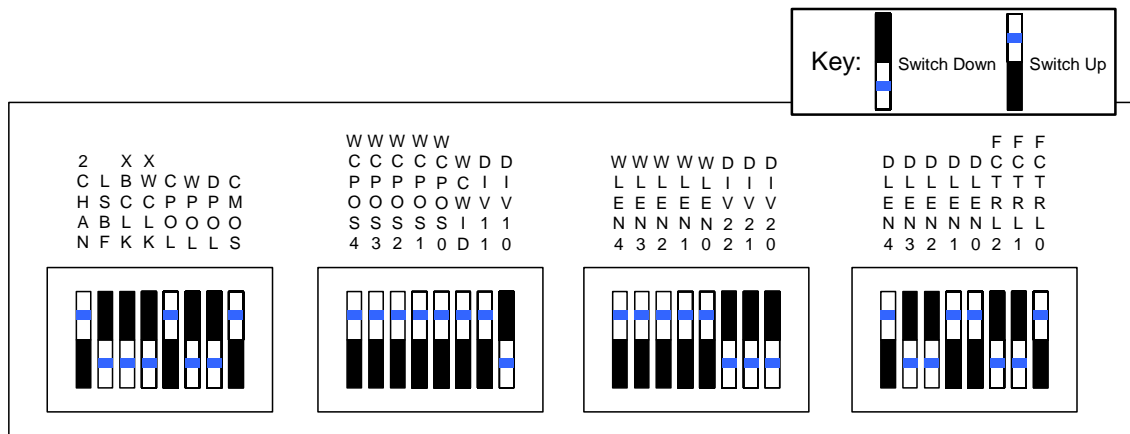

Figure 3. SIA-2322 Transmitter Switch Settings



6.1. DAC performance measurements

I2S digital inputs are provided by the external test system (i.e. the Audio Precision SIA 2322 adapter). Use the 9460_dac.txt script through the serial interface to configure the STAC9460/61/62/63. Use the 9460_DAC_FFT.at2c and 9460_DAC_THDvAMPL_sweep.at2c test procedures on the Audio Precision system to measure DAC performance.

6.2. ADC performance measurements

Only STAC9460 and STAC9462 audio codecs contain ADCs. ADC performance measurements can be achieved using either an internal loopback of the signal within the STAC9460/62 or with an external loopback of the signal by connecting SDO to SDI on the evaluation board. (The signal path for an external loopback test will include the DAC.)

For an internal loopback test, use the 9460_la2_adc_int_loopback.txt configuration script and the 9460_ADC_int_loop_FFT.at2c test procedure. For an external loopback test, use the 9460_la2_adc_ext_loopback.txt configuration script and the 9460_ADC_ext_loop_FFT.at2c test procedure. Use the 9460_ADC_THDvAMPL_sweep.at2c test procedure to perform a sweep of ADC THD+N measurements versus input amplitude, in either internal or external loopback mode.

7. EVALUATION BOARD SCHEMATICS

The following pages contain schematics for the STEEBAC9460B evaluation board.



C-Major™ Consumer Audio STEEBAC9460B Evaluation Board User's Guide

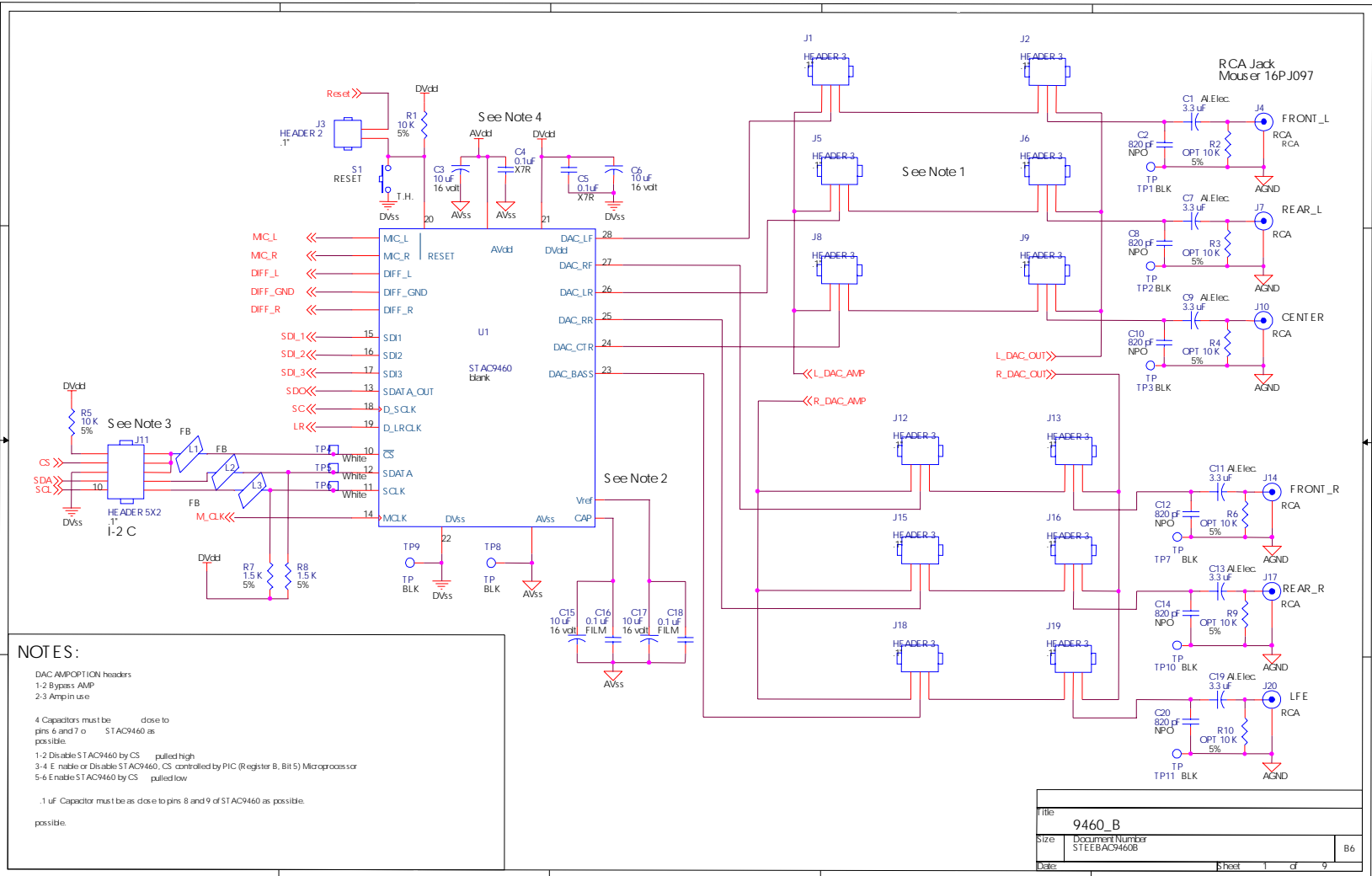

NOTES:

DAC AMPOPTION headers
 1-2 By-pass AMP
 2-3 Amp in use

4 Capacitors must be as close to pins 6 and 7 of STAC9460 as possible.

1-2 Disable STAC9460 by CS pulled high
 3-4 Enable or Disable STAC9460. CS controlled by PIC (Register B, BH5) Microprocessor
 5-6 Enable STAC9460 by CS pulled low.

.1 uF Capacitor must be as close to pins 8 and 9 of STAC9460 as possible.

possible.

Title	9460_B		
Size	Document Number	STEEBAC9460B	
Date	8/00	1	of 9

C-Major™ Consumer Audio STEEBAC9460B Evaluation Board User's Guide

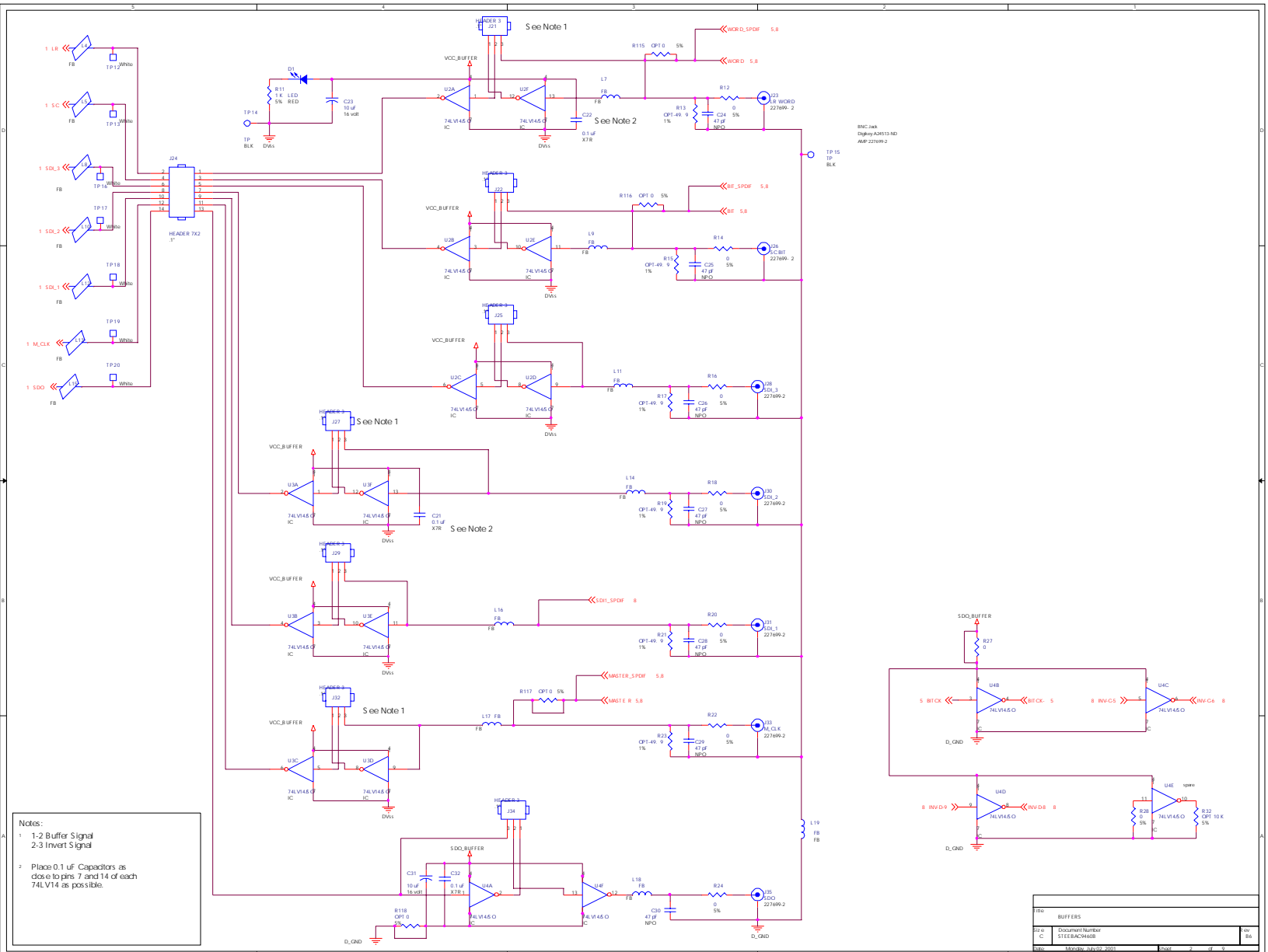

Notes:
 1 1-2 Buffer Signal
 2-3 Invert Signal
 2 Place 0.1 uF Capacitors as close to pins 7 and 14 of each 74LV14 as possible.

BUFFERS		Rev	8/0
Doc #	Document Number	Part	8/0
STEEBAC9460B	STEEBAC9460B	8/0	8/0



C-Major™ Consumer Audio STEEBAC9460B Evaluation Board User's Guide

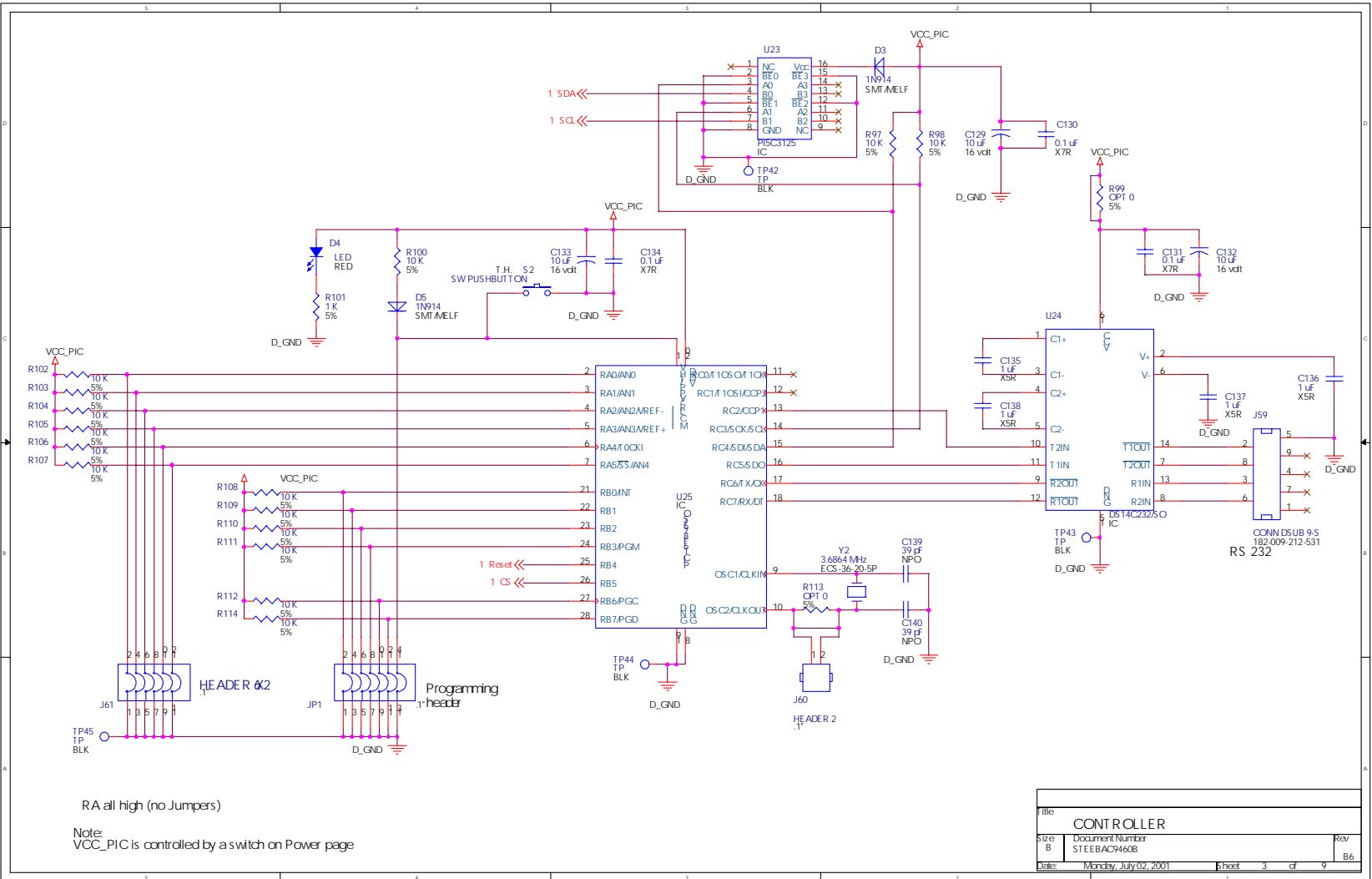

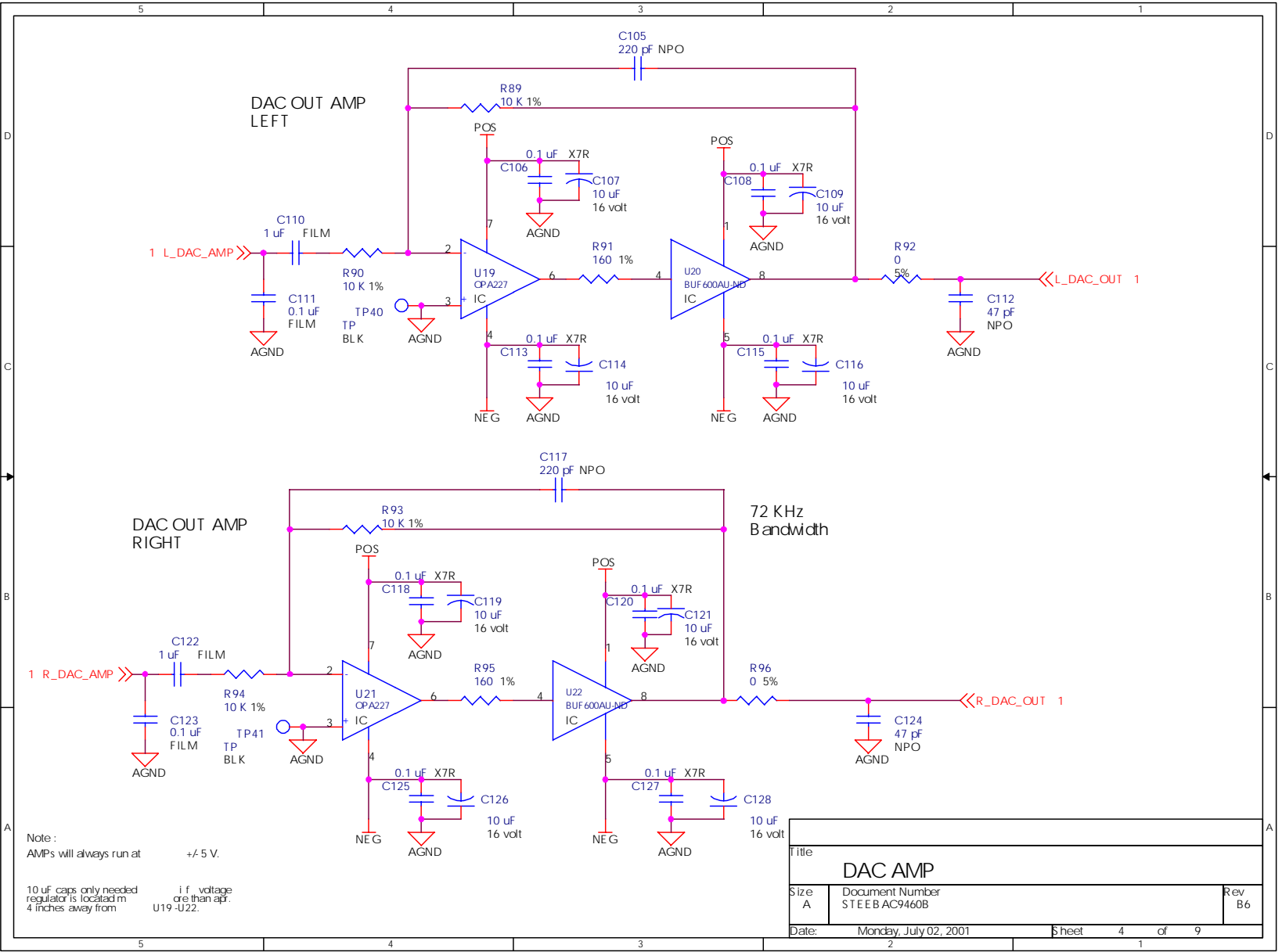



C-Major™ Consumer Audio
STEEBAC9460B Evaluation Board User's Guide

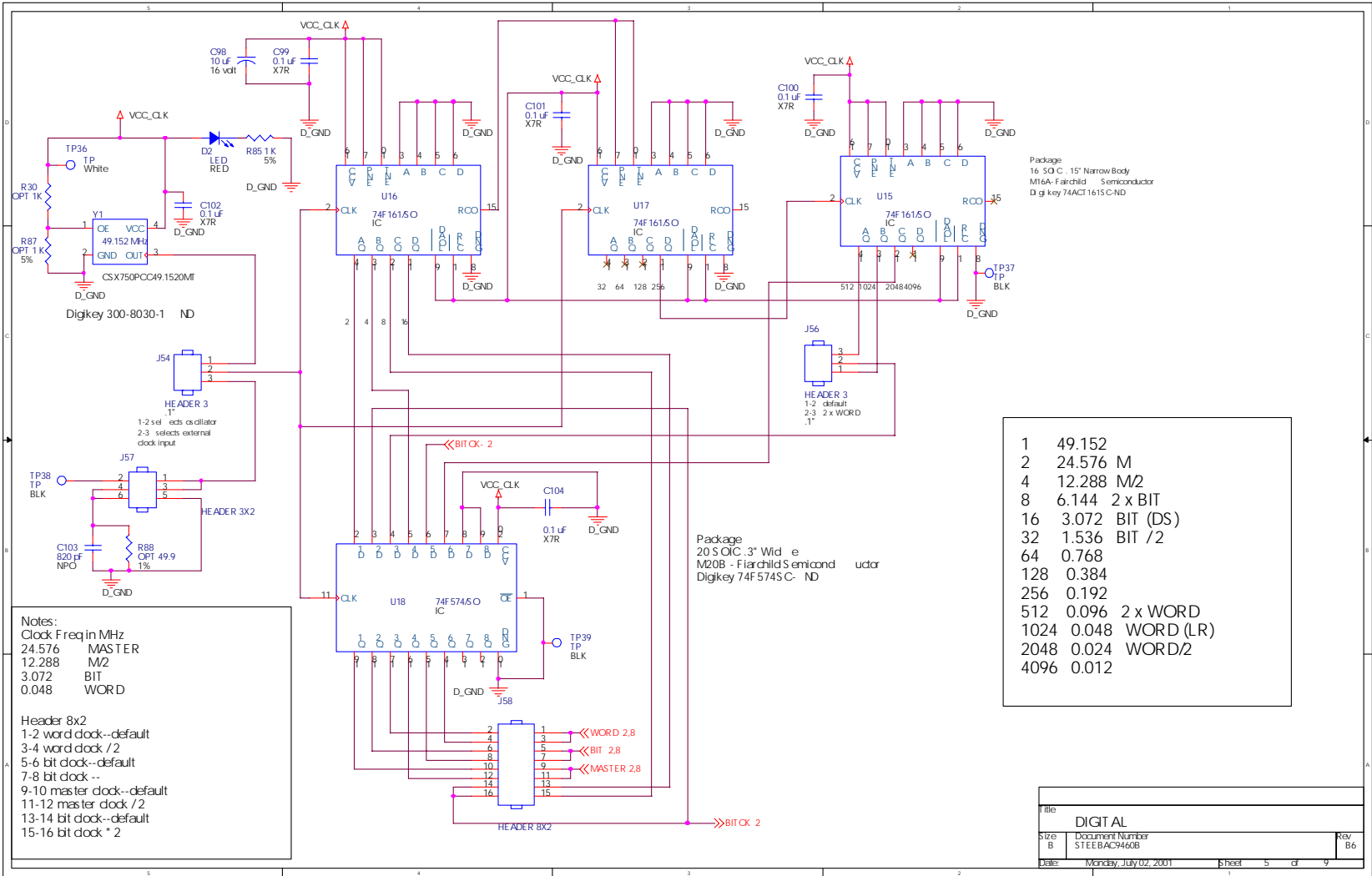

Notes:
 Clock Freq in MHz
 24.576 MASTER
 12.288 M/2
 3.072 BIT
 0.048 WORD

Header 8x2
 1-2 word clock--default
 3-4 word clock /2
 5-6 bit dock--default
 7-8 bit dock --
 9-10 master clock--default
 11-12 master clock /2
 13-14 bit dock--default
 15-16 bit dock * 2

1	49.152
2	24.576 M
4	12.288 M/2
8	6.144 2 x BIT
16	3.072 BIT (DS)
32	1.536 BIT /2
64	0.768
128	0.384
256	0.192
512	0.096 2 x WORD
1024	0.048 WORD (LR)
2048	0.024 WORD/2
4096	0.012

title		DIGITAL	
size	B	document number	STEEBAC9460B
date	Monday, July 02, 2001	sheet	5 of 9
rev	B6		

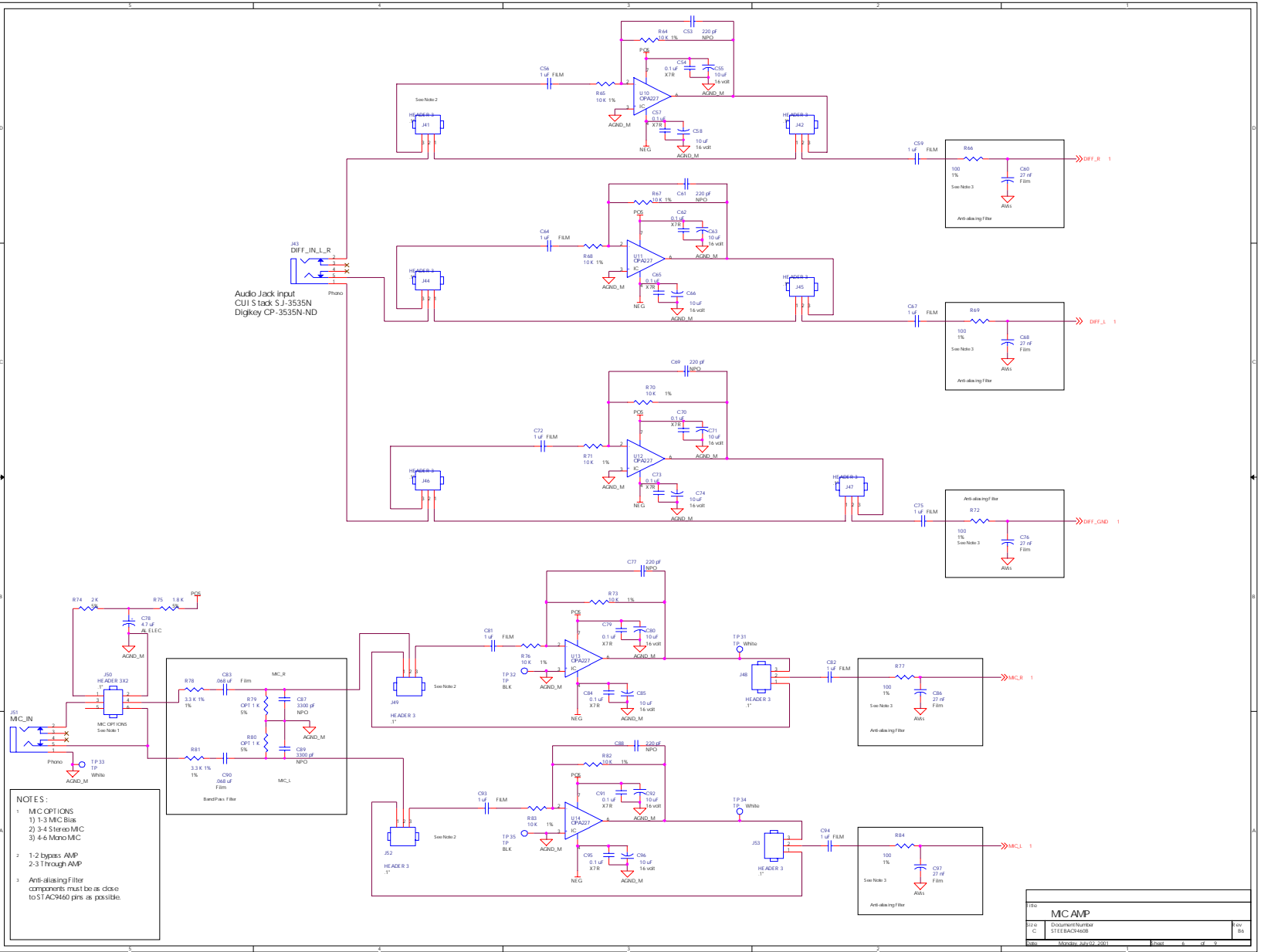

Audio Jack Input
 CUI S tack S J-3535N
 Digkey CP-3535N-ND

NOTES :

- 1 MC OPT1ONS
- 1) 1-3 MIC Bias
- 2) 3-4 Stereo MIC
- 3) 4-6 Mono MIC
- 1-2 bypass AMP
- 2-3 Through AMP
- 3 Anti-aliasing Filter components must be as close to STAC9460 pins as possible.

REV	MC AMP	Rev
REV	Document Number	Rev
C	STEEBAC9460B	5b
DATE	MOCKUP_2007_0301	Rev



C-Major™ Consumer Audio STEEBAC9460B Evaluation Board User's Guide

