

2005 FIRST Pneumatic Manual

The Advantages of Using Pneumatics in 2005

Fluid power technology encompasses both hydraulics and pneumatics. Hydraulic applications use pressurized fluids, mostly oil, while pneumatic applications use pressurized gases, mostly air. Mobile construction equipment uses a hydraulic pump mounted on the engine. The outlet of the pump is plumbed to a set of valves. Each valve is then plumbed to a cylinder. This allows you to distribute power from the engine all around the equipment. The same is true for a FIRST robot. Once you install the compressor operating one valve and cylinder combination, you've done most of the work. To add additional valve and cylinder combinations, you just tee into the pressure line and add in the additional circuit.

Weight

Compare the weight of several valves and cylinders to that of the motors, gears, belts, and chains used on some lift mechanisms and you will find the weight comparable, if not much lighter.

Simple to Design

Using pneumatics is much easier than building a motor; gear, chain and sprocket lift mechanism. Once you have reviewed the layout on page 15, you will find it very easy to build a circuit.

Adjustable Force

To adjust the force of the cylinder, all you have to do is adjust the regulator in front of it. The force is equal to the area of the cylinder piston times the pressure. Remember that the valves are rated at a minimum of 15-30psi to work properly.

Durable

All of us have problems burning up motors from time to time. You can stall an air cylinder against a load indefinitely and turn off the compressor. These are industrial grade products.

Strong

If you look at the force table on page 12, you have the option of using a small 3/4" bore cylinder at 20psi, which will produce a force of around 9 pounds. If you use a 2" bore cylinder at 60psi, you can get 180 pounds of force. As you can see, your options are wide open.

Custom Cylinders and a Rotary Actuator

You can now order the exact cylinder you need for the job and get them in a few days via regular UPS.

Last Minute Additions

At the last minute, you can add a cylinder and valve very quickly.

Congratulations on receiving your pneumatic kit for the FIRST 2005 competition.

This year we have worked very hard to make it easier for you to use pneumatics on your robot. We have also chosen components that match each other. This year almost all the major components have been manufactured exclusively for this year's competition. There are some exciting new additions to this year's kit, which we hope will make using pneumatics easier than ever

COMPRESSOR

We have the same compressor provided by **Thomas Industries** that we've had over the last few years. The compressor will put out approximately 125psi before the **Norgren** relief valve opens. Because the compressor can produce a significant amount of vibration, we have included vibration isolation mounts donated by the **Lord Corporation**. They can be screwed directly into the feet of the compressor as shown on the following picture. In order for these to isolate the vibration, they need to be mounted to a stiff piece of metal such as a 1/4" aluminum plate. The distance between the front feet is 3.5". The distance from the centerline of these feet to the rear foot is 5.19". A spike relay should be used to control the power to the compressor using a 20amp breaker, not a fuse. Ensure that the relay is programmed to provide "forward" power only to the compressor. Do not reverse the compressor!

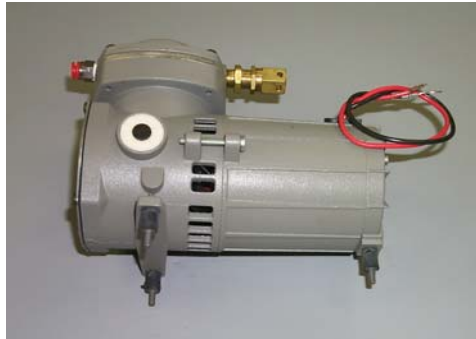

Warning: The compressor head can get quite hot during extended operation.

PRESSURE SWITCH

We have included a pressure switch manufactured by **The Nason Company**. These switches are normally closed. The switches will open at approximately 115psi and will not close again until the pressure drops to approximately 95psi. This will allow you to turn off the compressor once you are up to 115psi, saving power in the battery. It should be wired directly to the robot controller digital input bank with PWM type cable. No specific Digital Input Port is designated for the pressure switch. The Robot Controller must be programmed to react to the Input Port that is connected to the pressure switch. The Robot Controller will activate the designated Spike Relay to turn the Compressor "on" and "off". There is no default program in the Robot Controller to control the Compressor power. Do not put the pressure switch in series with the power supply to the compressor.



TANKS

We have two tanks from **Clippard Instruments**. They should be mounted right after the compressor, before the Norgren primary pressure regulator.



REGULATORS

Norgren has donated the primary pressure regulator. These are relieving regulators. Assume that you extend the cylinder or the apparatus the cylinder is attached to against a wall. Then push against the wall with your robot. That would increase the pressure in the cylinder. The increased pressure will relieve out of the regulator and the cylinder will slowly retract. This regulator has a maximum output pressure of 60psi. This regulator must be placed in-line right after the tanks to limit the pressure to all working circuits to 60psi. It is adjustable and the outlet pressure may be reduced at your discretion. Look at the top of the regulator. You will note that one port extends out a little bit more than the others. It also has an arrow on it to denote the outlet of the regulator. The opposite port is the inlet. A pressure gauge may be placed in either of the other ports. You will have to plug the other gauge port with the enclosed hex plug.



Monnier has donated the secondary regulator, which has a yellow ring around it. This is also a relieving regulator. Its purpose is to allow you to have a reduced pressure leg, if needed. There is an arrow denoting the direction of flow. The gauge may be placed in either of the other ports. The Monnier bag provides you with plugs to put into the gauge ports.



ELECTRIC VALVES

SMC has provided two valves. The following relates to the double solenoid valve:

If you pulse one of the solenoids to make the cylinder extend, you must then pulse the opposite solenoid to make it retract. Either solenoid may be left in the energized state. This is a great valve to use to maintain position when the power is turned off at the end of the match. If you use a single solenoid valve and the power is turned off, the valve would shift back to its original position and the cylinder will retract. A double solenoid valve will maintain its position until you turn on the opposite solenoid. The orange buttons on the top of the valves are manual overrides. With a double solenoid valve you can depress the override and the valve will shift and stay in that position. The valve is pilot operated and requires a minimum

pressure of 20 psi to work. The valve comes ready to assemble with two gaskets. Use the thicker of the two as the other is for another purpose. Always avoid turning on both solenoids at the same time. While this won't hurt the valve, you cannot be sure which way the spool will shift.

You need to install the pilot valves that come in the kit and then mount it on the subplate as shown below. Please note that the subplate was shipped separately to the kickoff sites. See the web site www.smcusa.com and click on the FIRST link for more information.

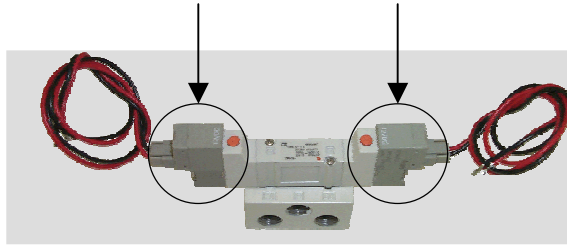

FESTO has also supplied a single solenoid valve. In order to wire the valve you must remove the white plastic pin protector that comes over the pins. Instructions in the package explain how to wire the valve. The fittings are the push to connect type so all you have to do is push in the tubing. The manual override will not maintain its position if released, similar to the single solenoid valve from **SMC**.



Bosch-Rexroth has also provided us with a single solenoid valve. The fittings allow you to push on the tubing and then tighten down on the tubing with the nut. The pressure port is shown on the top of the valve and marked "P". Flow comes out the "B" port and switches to the "A" port when the coil is energized. Two connectors are also included which allows you to crimp and wire on to the connector and then just push it over the spade. The yellow arm on the opposite side of the valve is the manual override. On this valve you can turn the override on and leave it in that position. Note there is no nut on the "R" port, which is the exhaust port. **Please remove the Black nuts which are for metric tubing and use the Gray nuts which are included.**



FLOW CONTROLS

We have flow controls donated by **SMC Pneumatics**. The purpose of a flow control is to control the speed of the cylinder when it is extending or retracting. Always mount these into the ports of the cylinders before you hook up the tubing.

Warning: Even if flow controls are used or the needle is turned out counter clockwise, the cylinder can extend very quickly. Always stay clear of any cylinder in motion.



PLUG VALVE

Parker Hannifin donated the plug valve. This valve can be used to release all the air in the system.



BRASS FITTINGS

Parker Hannifin donated all the brass fittings. These are useful where you want to plug a port or plumb from one size port to another. It is important to note that all male threads require Teflon tape to seal properly. Wrap the tape around the fitting, leaving the first two threads free of tape. This is because the threads are tapered and the tape may come loose from the first thread or so and clog up one of your valves.



QUICK CONNECT FITTINGS

SMC Pneumatics donated the quick connect fittings. These are really easy to use. All you have to do is push the tube into the fitting. Make sure you push the tubing all the way into the fitting. To release the tubing, just push on the release button and then pull the tubing out. Don't attempt to pull the tubing without first pushing the release button. Two 5/32 fittings were included should smaller tubing be required. However, that tubing must meet the same pressure requirements as the 1/4" tubing included in the kit. **The picture below shows a representative example of these fittings but does not include all the ones in the kit.**



TUBING

SMC Pneumatics has donated the tubing.

KIT CYLINDERS

We have included a cylinder from **Parker-Hannifin Manufacturing**. It is included in the kit for you to get started and understand pneumatics. Hopefully, you will find a use for it on your robot. **Please note: The switches provided by BIMBA will not work with this cylinder, as it has no magnetic piston.**

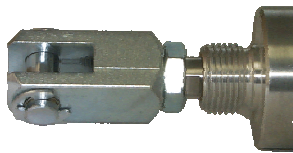

CUSTOM BIMBA CYLINDERS

You will again be able to order custom cylinders for your robot again this year. You have a choice of 3/4" bore (diameter), 1-1/2" bore and 2" bore. You can order the amount of stroke you require. This will significantly increase your ability to design a great robot. Most of the bore and stroke models are in stock and **Bimba** is ready to ship directly to your team. This year all the actuators can be ordered with a magnetic piston and two magnetically operated reed switches. These switches will close when the piston is underneath them. It is not recommended to try to sense a mid-stroke position with these. There is a PowerPoint presentation on www.pneumaticsfirst.com that contains some great discussions on how to design your cylinders in order to get the proper height for a lift mechanism.

This year rather than faxing your order to HPE Automation you can go directly online and order them. Please go to www.bimba.com and click on the FIRST link and follow the instructions. Quantities of no charge custom cylinders will be limited to **3** per team. Additional cylinders can also be purchased through a Bimba or Parker-Hannifin Distributor. You can find a distributor in your area by going to:

<http://www.bimba.com/distrib/distrib.htm>

or

<http://www.parker.com/distloc/english/search.asp>

How to calculate the retracted and extended length of a cylinder

Look at the drawing of the 1-1/2" bore cylinder (page 10). You will notice that the cylinder pivots about a pivot pin located in the rear of the cylinder. There is a dimension on the drawing from that pin to the back of the thread on the rod end. That dimension is "4.38 + Stroke". We will use this later. Look at the drawing of the rod clevis. There is a locking nut shown on the drawing. If you look, there is a dimension of the width that is 0.25". The locking nut threads on the rod first and is used to keep the clevis in place. Lastly, look at the dimension 1.31" on the rod clevis.

Therefore, if you thread the locking nut on the rod thread all the way to the bottom of the thread and then tighten the clevis against it, you can calculate the distance from the rear pin to the clevis pin. This is called the pin to pin distance. Assume you want to move something 8 inches. You will need to order an 8" stroke cylinder.

To find the retracting pin-to-pin dimension, do the following:

Base dimension	= 4.38"
Stroke	= 8.00"
Locking nut width	= 0.25"
<u>Clevis dimension</u>	= 1.31"
Pin-to-Pin Retraction	= 13.94"

To find the extended pin-to-pin dimension, just add the stroke:

Pin-to-Pin retracted	= 13.94"
<u>Stroke</u>	= 8.00"
Pin-to-Pin Extended	= 21.94"

Note: The retracted length may be somewhat longer by not tightening the clevis all the way to the end of the thread.

3/4" BORE

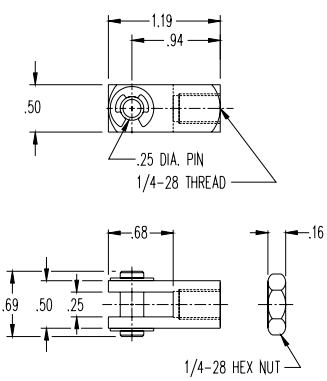
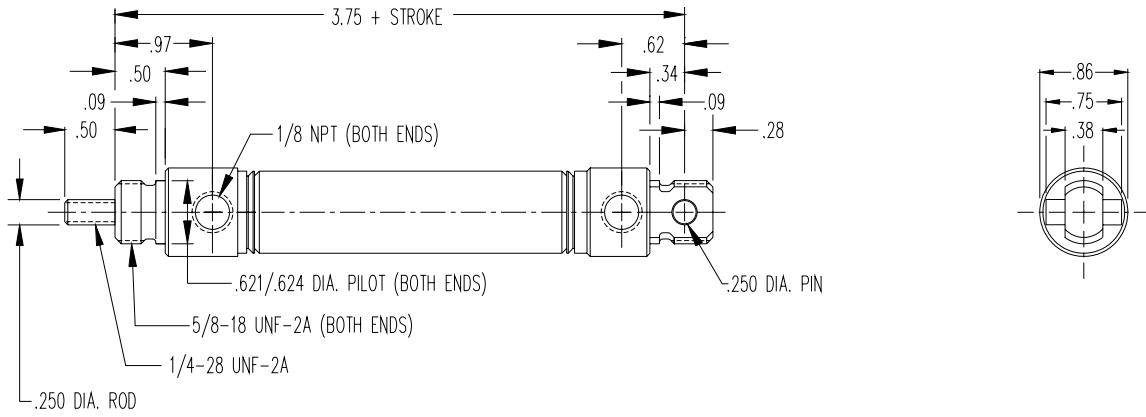

Rod Clevis
Bimba Part Number **D-166-3**

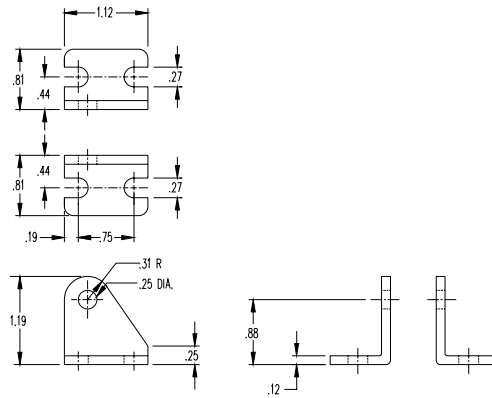

Rear Pivot Bracket
Bimba Part Number **D-167**

1-1/2" BORE

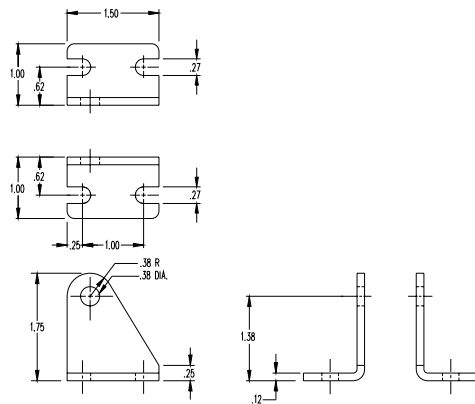
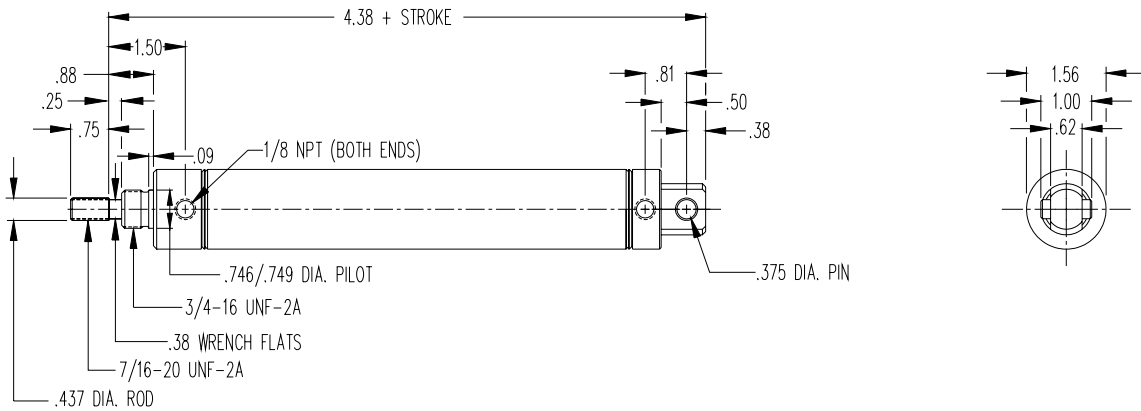

Rear Pivot Bracket
Bimba Part Number **D-229**

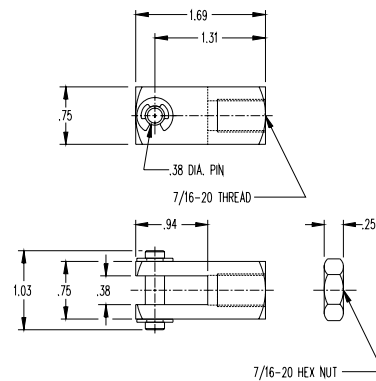

Rod Clevis
Bimba Part Number **D-231-1**

2" BORE

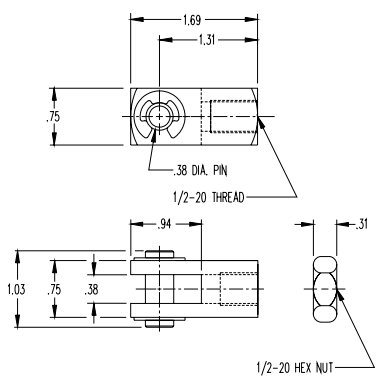
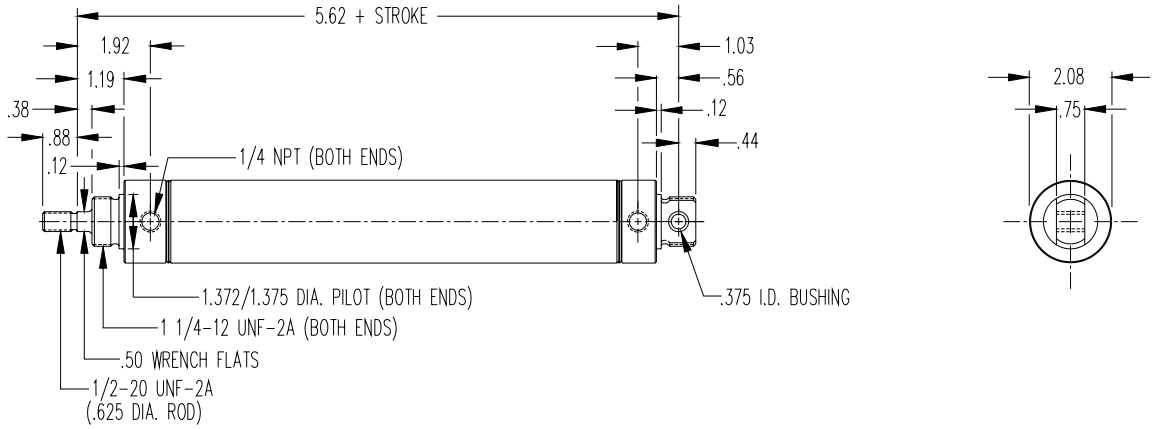

Rod Clevis
Bimba Part Number **D-231-3**

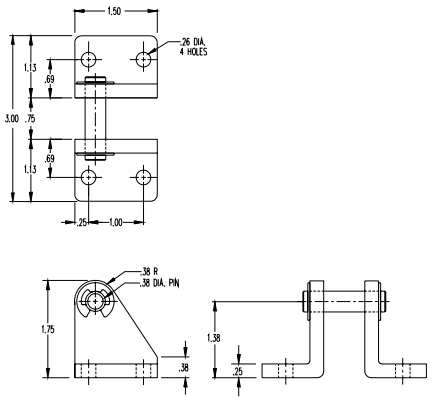

Rear Pivot Bracket
Bimba Part Number **D-620**

**Extend and retract forces
of all three bore sizes**

	3/4" Bore	3/4" Bore
Pressure	Force Extended	Force Retracted
(pounds/sq. inch)	(pounds)	(pounds)
20	9	8
25	11	10
30	13	12
35	15	14
40	18	16
45	20	18
50	22	20
55	24	22
60	26	24
	1-1/2" Bore	1-1/2" Bore
Pressure	Force Extended	Force Retracted
pounds/sq. inch	(pounds)	(pounds)
20	35	32
25	44	40
30	53	48
35	62	57
40	71	65
45	79	73
50	88	81
55	97	89
60	106	97
	2" Bore	2" Bore
Pressure	Force Extended	Force Retracted
pounds/sq. inch	(pounds)	(pounds)
20	63	57
25	79	71
30	94	85
35	110	99
40	126	113
45	141	128
50	157	142
55	173	156
60	188	170

Rotary Actuator

Bimba is again offering you a rotary actuator. This is ideal for grippers, gear shifters, brakes etc. If you choose to use one of these you will only be allowed to order 2 free cylinders instead of three. As with the cylinders, you may order a magnetic piston, which will activate the switches when the piston is directly underneath the switch. The rotational tolerance of the unit is 90 degrees -0 degrees +15 degrees. Exact angle adjustment should be made with external stops. The theoretical torque of this actuator is 0.166 inch-lbs/PSI. Using the maximum allowed pressure of 60 psi the unit could develop a theoretical torque of almost 10 inch-lbs.



The following are the specifications for the rotary actuator.

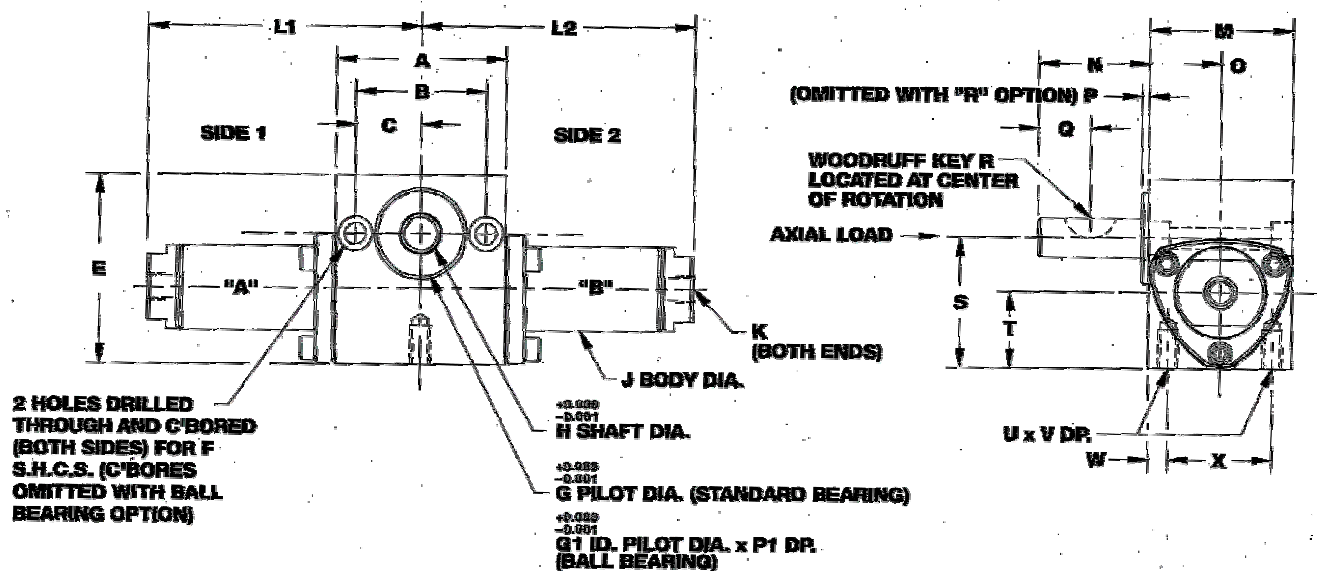

Bore	A	B	C	E	F
0.075	1.62	1.25	0.62	1.81	#10 S.H.C.S.
G	G1	H	J	K	M
0.875	0.875	0.375	0.82	#10-32	1.37
N	O	P	P1	Q	R
1.06	0.69	0.06	0.06	0.5	Below
S	T	U	V	W	X
1.25	0.73	#10-24	0.38	0.19	1

The woodruff key is 0.0625" wide and 0.032 " high

Typical 2004 Pneumatic Circuit

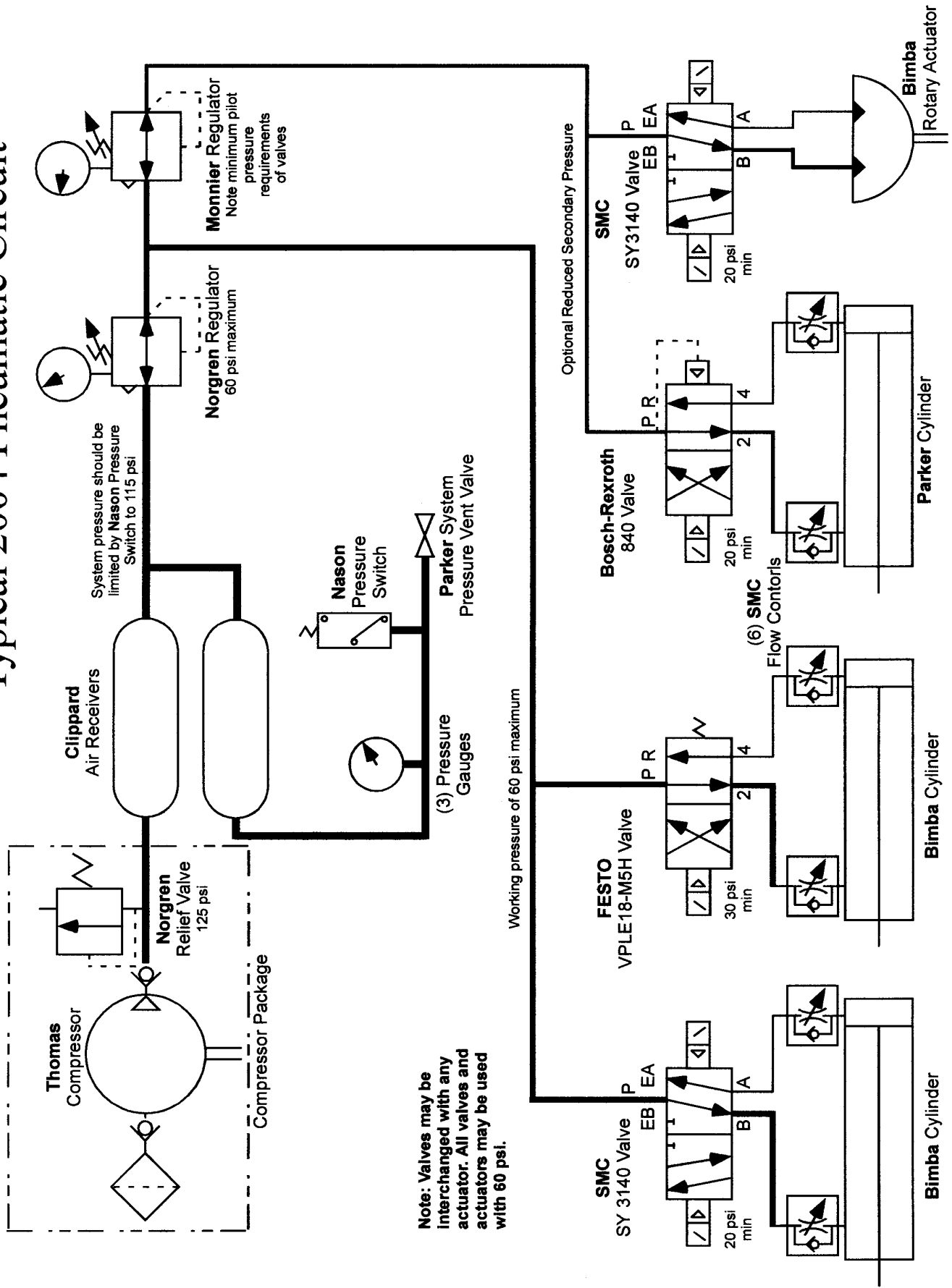

Note: Valves may be interchanged with any actuator. All valves and actuators may be used with 60 psi.

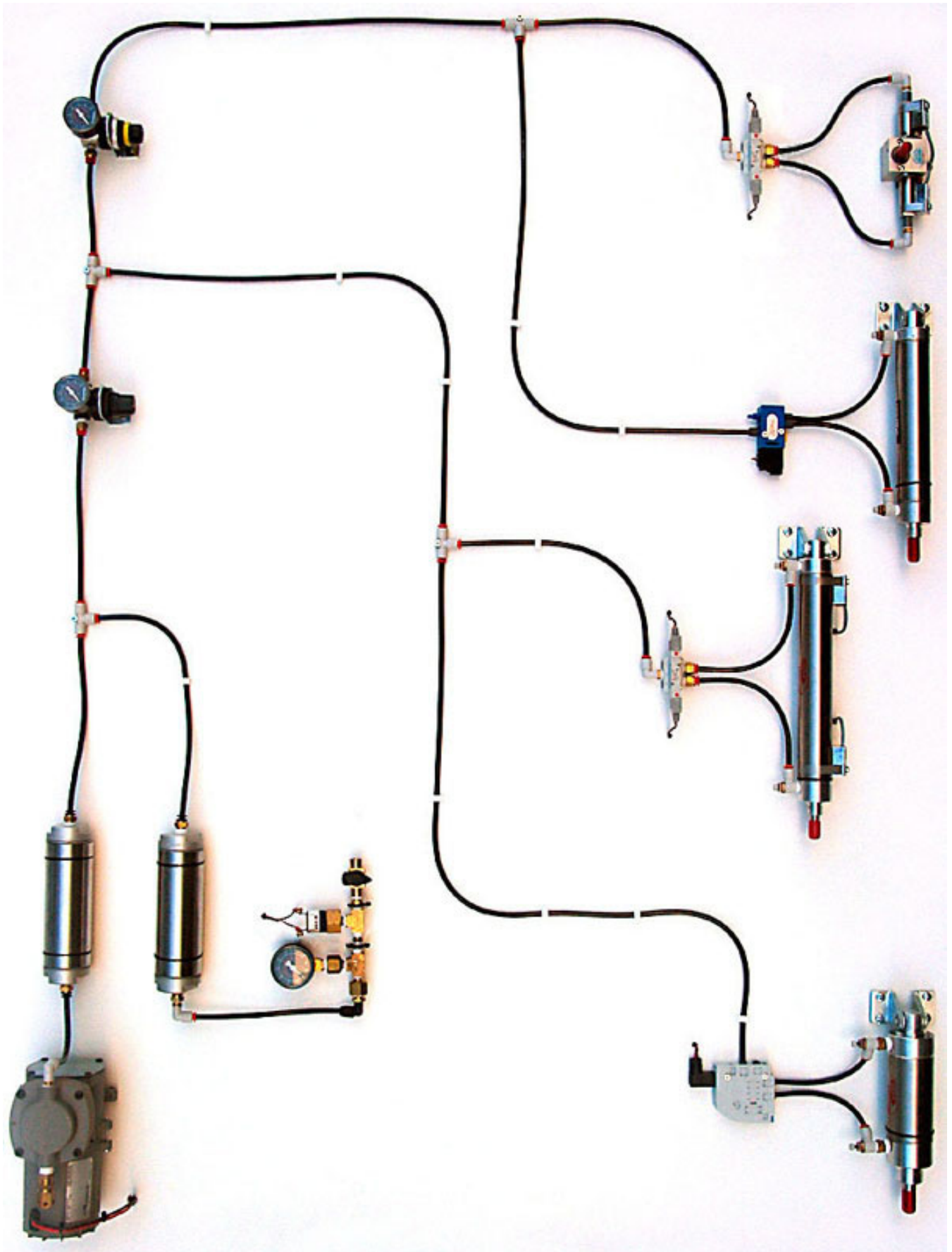

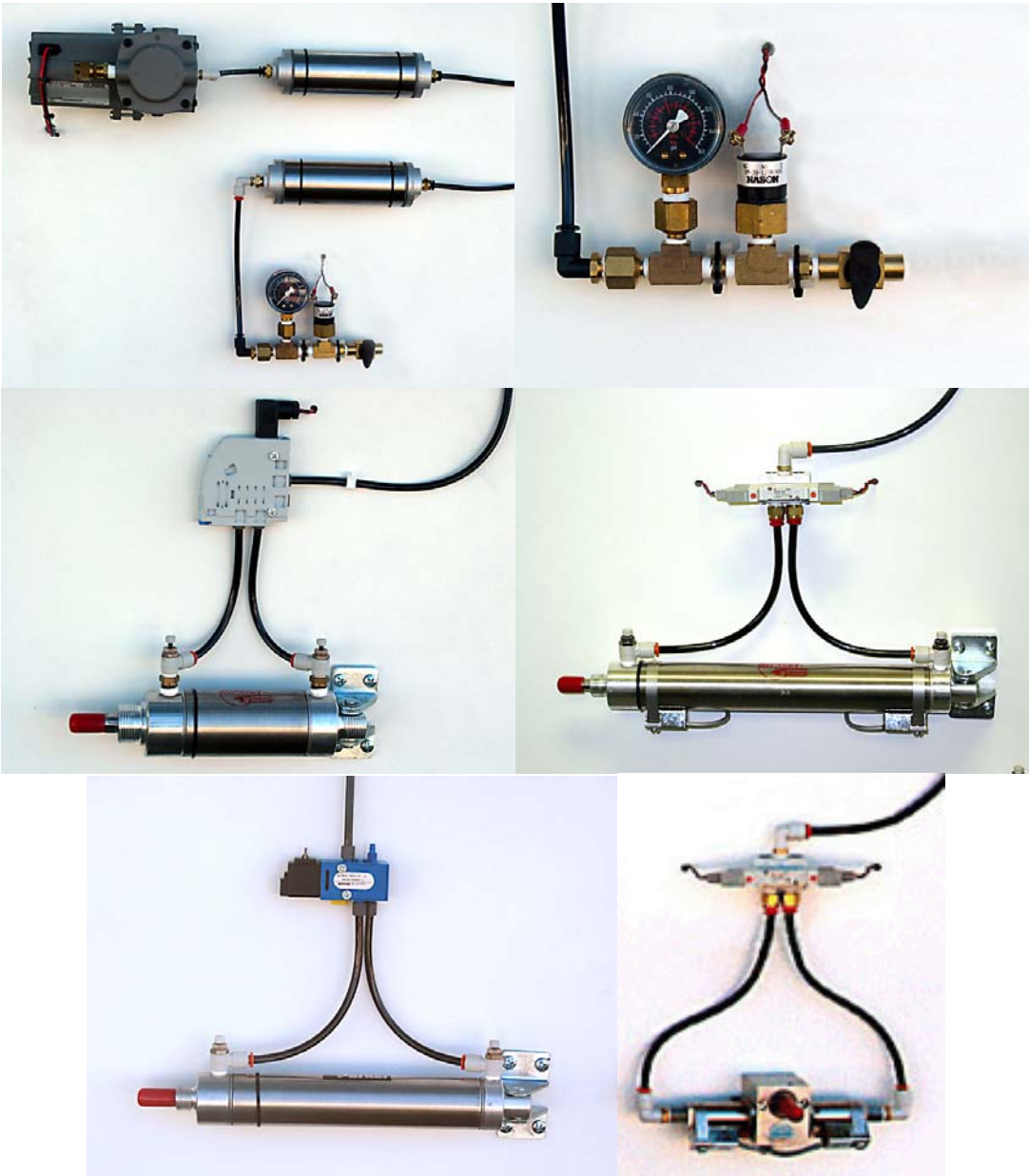

FIRST
Pneumatic Component
Bill of Material

Vendor	Quantity	Part Number	Product Weight Each	Description
Per Kit				
SMC Pneumatic Kit				
SMC	2	SY3240-5LOZ	3.0 oz.	Double solenoid valve, (2) sub plates, (4) 12vdc pilot valves and (4) wires-separate
SMC	6	NAS2201F-N01-07S	0.6 oz.	Flow control
SMC	10	KQH07-34S	0.3 oz.	Fitting, Straight 1/4 Tube
SMC	1	KQ2H03-34S	0.4 oz.	Fitting, Straight 5/32 Tube
SMC	1	KQ2L03-34S	0.4 oz.	Fitting, 90 Elbow 5/32 Tube
SMC	5	KQ2L07-34S	0.2 oz.	Fitting, 90 Elbow 1/4 Tube
SMC	10	KQL07-35-S	0.2 oz.	Fitting, 90 Elbow 1/4 Tube
SMC	5	KQT07-00	0.5 oz.	Fitting, 90 Branch 1/4 Tube
SMC	2	KQY07-34S	0.3 oz.	Fitting, Male Run T 1/8 NPT -1/4 Tube
SMC	2	KQY07-35S	0.3 oz.	Fitting, Male Run T 1/4 NPT -1/4 Tube
SMC	1	TIUB07G-20	1 #	1/4" OD tubing - 20 meters
Parker Cylinder Div.				
Parker	1	1.5DPSR8.00	7.3 oz.	Cylinder 1.5" bore x 8" stroke
Parker	1	L071310300	1.6 oz.	Cylinder pivot bracket set
Parker	1	L071300400	1.0 oz.	Cylinder rod clevis
Parker Brass Div.				
Parker	1	PV609-2	2.4 oz.	Manual 2-way plug valve
Parker	4	2203P-2	1.3 oz.	Union Tee
Parker	6	222P-4-2	1.1 oz.	Adapter 1/4" female to 1/8" male
Parker	6	216P-2	0.4 oz.	Hex nipple 1/8"npt
Parker	12	209P-4-2	0.4 oz.	Bushing 1/8" female to 1/4" male
Parker	6	218-2	0.3 oz.	Plug 1/8"
Parker	6	218-4	0.7 oz.	Plug 1/4"
Norgren Kit				
Norgren	1	16-004-015	5.1 oz.	120 psi relief valve
Norgren	1	R07-153-RNEA	4.7 oz.	Main regulator w/60psi max output
Norgren	1	18-025-003	0.7 oz.	Regulator mounting bracket and nut
Norgren	1	18-013-212	0.8 oz.	Gauge
Festo Valve	1	13026684	3.3 oz.	Single solenoid valve
Bosch/Rexroth	1	P-026641-00004	2.7 oz.	Single Solenoid Valve w/ electrical connectors & 1/4" tubing connectors
Clippard	2	AVT-32-16	14 oz.	Volume Tank 2" bore by 6" length
Nason	1	SM-2B-115R	2.1 oz.	Pressure switch
Monnier	1	101-3002-1	3.2 oz.	Secondary pneumatic regulator
Monnier	1	13536	1.2 oz.	Regulator mounting bracket and nut
Wika	3		4.0 oz.	Pressure Gauges
Lord Corporation	1	SMB003-0100-2	0.3 oz.	Vibration isolators for compressor
HPE Teflon tape	1	HPE	0.2 oz	1/4" by 100"
Thomas Compressor	1	405ADC38-12	4 lbs.- 12oz.	Compressor
BIMBA	3	Not included in the kit		Special order Actuators

The following companies provided product for the 2004 Competition:

**Bimba Manufacturing
Bosch-Rexroth
Clippard Instrument Laboratory, Inc.
Festo
Lord Corporation
Monnier, Inc.
Nason Corporation
Norgren
Parker Hannifin, Inc.
SMC Pneumatics, Inc.
Thomas Industries, Inc.
Wika Instrument**

Web Sites for Product Suppliers and Foundations

Bimba Manufacturing	- http://www.bimba.com/
Bosch-Rexroth	- http://www.boschrexroth.com/
Clippard Instrument Laboratory, Inc.	- http://www.clippard.com/
Festo	- http://www.festo.com/
Lord Corporation	- http://www.lordmpd.com/
Monnier, Inc.	- http://www.monnier.com/
Nason Company	- http://www.nasonptc.com/
Norgren	- http://www.norgren.com/
Parker Hannifin, Inc.	- http://www.parker.com/
SMC Pneumatics, Inc.	- http://www.smcusa.com/
Wika Instruments	- http://www.wika.com/
FPEF	- http://www.fpef.org/

FIRST Free Pneumatic Components Order Form



**** A maximum of 3 free cylinders may be ordered. You may substitute 1 rotary actuator for a cylinder. LIMIT IS 3 ITEMS! Additional cylinders and rotary actuators may be purchased from local distributors. See below for details. ****

How to Order

The example is a 2" bore x 6" stroke cylinder with a magnetic piston.

M - 31 6 - DXP

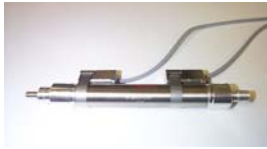

Air Cylinders

*M-Magnet	Bore	Stroke in inches	Mounting
(Optional) Includes (2) MRS-.087-B position sensors	04 = 3/4" 17 = 1 1/2" 31 = 2"	0.5, 1, 1.5, 2, 2.5, 3, 4, 5, 6, 8, 10 0.5, 1, 1.5, 2, 2.5, 3, 4, 5, 6, 7, 8, 9, 10, 11, 0.5, 1, 1.5, 2, 2.5, 3, 4, 5, 6, 7, 8, 9, 10, 12, 24	DP for 3/4" DP for 1 1/2" DXP for 2"

Please check the Bimba web site for available strokes in each bore size

All cylinder orders include clevis, jam nut and pivot brackets.

Please allow up to 4 days for shipment.

The example is a 3/4" bore, 90° rotary actuator with magnetic pistons.

PT - 017 090 - M



90° Rotary Actuators

Model	Bore	Rotation	*M-Magnet
PT	017 - 3/4" (Only bore available)	090 (90° is the only rotation available)	(Optional) Includes (2) MRS-.087-B position sensors

To order, go to: www.bimba.com and click on the FIRST link.

Shipments are sent UPS Ground Complete at no cost to teams.

IF Express Service is needed, each team is responsible for charges. Supply your carrier and account number

Technical Help: fhord@hpeco.com

Emergency Only—Phone: 954-429-9560

*After your order is placed, go to www.bimba.com and click on "Order Tracking" to check the status of your order. (Customer PO = Team No.)

**Any additional actuators or accessories can be purchased through your local Bimba or Parker-Hannifin Distributor. To find one in your area go to:

<http://www.bimba.com/distrib/distrib.htm>

or

<http://www.parker.com/distloc/english/search.asp>