

ITEM	QTY.	DESCRIPTION	LENGTH	REMARKS
1	AR	1 1/4"x1 1/4"x3/8" 6063 ALUMINUM TUBING	.	-
2	AR	1 1/4" SCHED40 ALUMINUM TUBING	.	-
3	AR	3"x3/16" 6063 ALUMINUM PLATE	.	-
4	AR	6"x3/16" 6063 ALUMINUM PLATE	.	-
5	2	TOP RAIL ASSEMBLY	.	-
6	2	LEG, LONG	.	-
7	2	BRACE, LONG	.	-
8	2	LEG, SHORT	.	-
9	3	BRACE, SHORT	.	-
10	1	BOTTOM PLATE, FRONT	.	-
11	1	BOTTOM PLATE, REAR	.	-
12	2	TETRA STOP	.	-

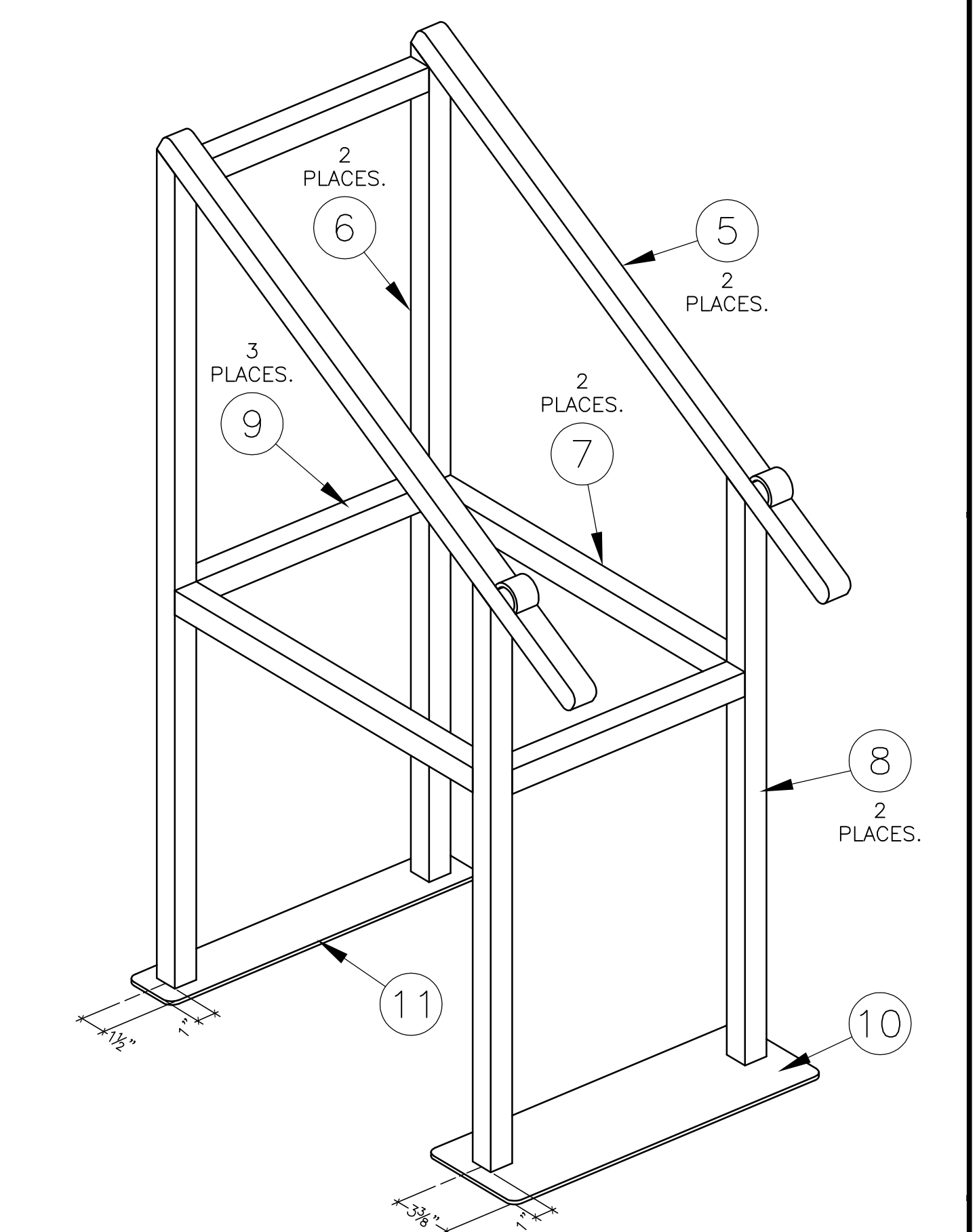
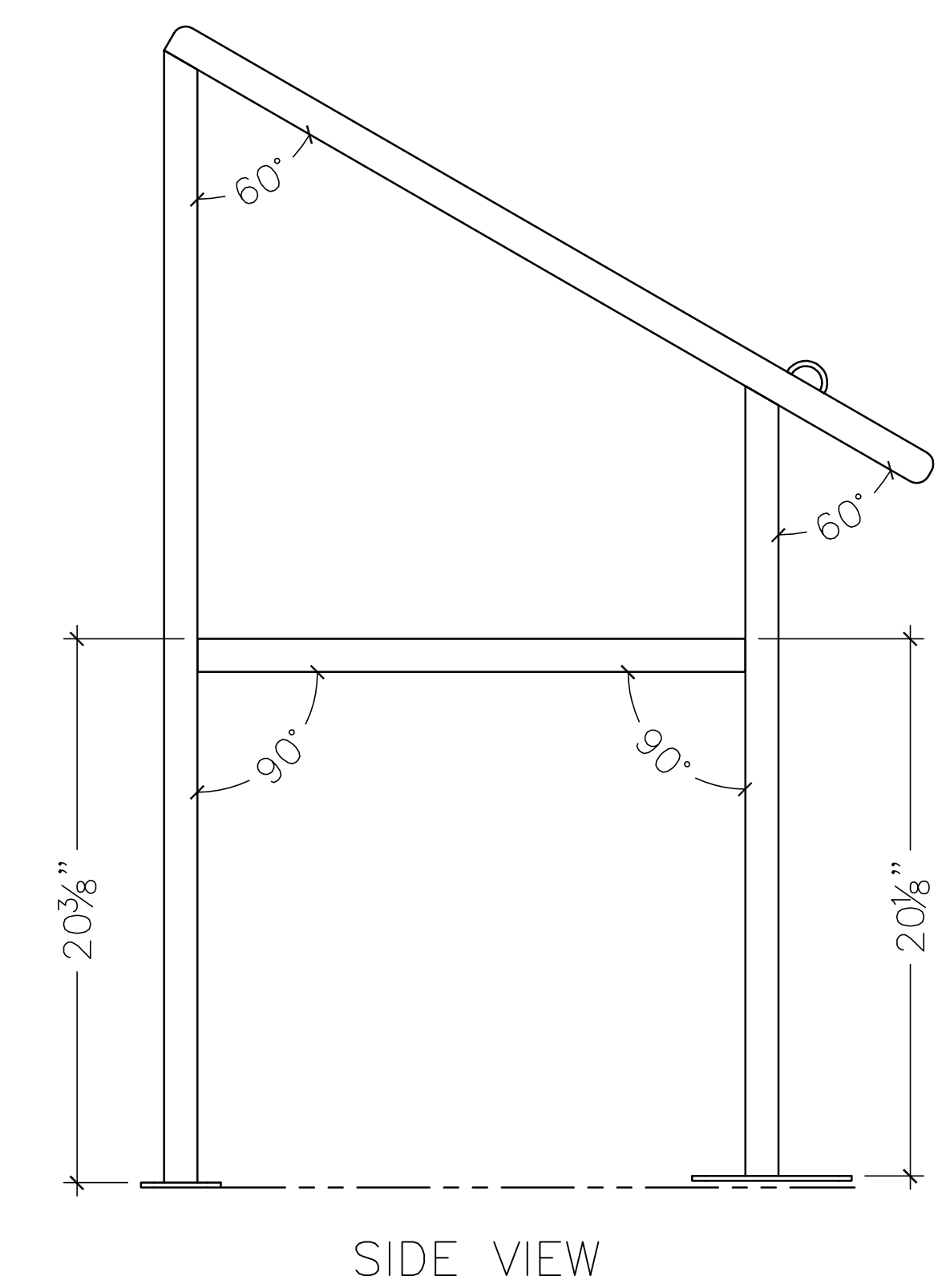

REV.		FROM	BY	DATE	FIRST 200 Bedford Street, Manchester, N.H. 03101 (603) 666-3906 ♦ FAX (603) 666-3907				
UNLESS OTHERWISE SPECIFIED									
TOLERANCE		PERPENDICULAR WITHIN			TITLE				
INCHES		PARALLEL			2005 FIELD ELEMENTS				
FRAC.	1/32	FLAT OR STRAIGHT			TETRA LOADER ASSY				
.00	1/2	CONCENTRIC T.I.R.			DRAWN BY	DATE	SCALE	CHECKED	DATE
.000	1/2	RADII : 1/2	SURFACE FINISH		JR2D2	12/07/04	NONE		
.0000	1/2	HOLES : 1/2			SIZE	No. NONE		SHEET NO.	1
FSCM									