

Inertial Navigation – Forty Years of Evolution

by A. D. KING, B.Sc., F.R.I.N.,
Marconi Electronic Systems Ltd.

For over forty years, this Company has been one of the world's significant players in the field of inertial navigation. From its inception, as an almost-impossible, barely-affordable technology for guiding strategic missiles, to today's acceptance of it as an everyday fact of life, the art and craft of inertial navigation still retains some of its mystique, and continues to provide stretching challenges in engineering.

This article doesn't pretend to be a textbook – there are plenty of excellent and readable texts available (see, for example, refs. (1-3)). This paper will attempt to explain only what is necessary in order to understand the significance of the current and future trends.

Principles of Inertial Navigation

Consider an accelerometer as an instrument that measures acceleration along a single axis. Integrate the output once, and you have velocity. Integrate again, and you have position – or rather, change of position – along the accelerometer's axis. If you know the direction of travel, you can deduce current position. Inertial Navigation is simply a form of 'dead reckoning'. You need to know the starting point – an inertial navigation device/system (I.N.) can't find its initial position on the earth (it can find latitude, with difficulty, but not longitude).

Take three accelerometers, with their sensing axes orthogonal. Arrange them so that their axes are aligned north-south, east-west, and vertical. To maintain this orientation when the vehicle manoeuvres, the accelerometers are suspended in a set of three gimbals that are gyro-stabilized to maintain the direction. I will be describing 'strapdown' arrangements later, but it always seems easier to explain the principles by starting with the 'gimballed' configuration (see fig. 1).

The gyros, similarly, are single-axis devices, of a type known as 'integrating' gyros – that is, they give an output proportional to the angle through which they have been rotated (about their input axes). The gyros are used as the sensing elements in null-seeking servos, with the output of each gyro connected to a servo-motor driving the appropriate gimbal, thus keeping the gimbal in a constant orientation in inertial space.

Integrating gyros also have what is called a 'torquer', a means of precessing the input axis at a

A. D. King joined Ferranti in 1966, initially working on development of navigation displays for aircraft, including the Harrier and Tornado. In 1975 he became Chief Engineer of a group with responsibility for many inertial navigation systems including the guidance system for the Ariane launcher. In 1981 he became manager of the Company's gyro business, and in 1989 became Chief Engineer of the Navigation and Electro-optic Systems Division. Ferranti Defence Systems was acquired by GEC-Marconi in 1990 and is now part of Marconi Electronic Systems. (E-mail: anthony.king@gecm.com)



rate proportional to input current. This forms a convenient means of cancelling out any drift errors in the gyro, and also provides another function that will be described below.

The gimbals, as shown, have a bearing at each end. Each has a motor, built around one of the bearings, and at the other end a synchro (an electromagnetic angle-measuring device). No matter how the vehicle manoeuvres, the innermost gimbal maintains its orientation in inertial space. The synchro on the innermost gimbal thus measures azimuth (or heading), the synchro on the middle gimbal measures pitch, and that on the outer gimbal measures roll.

The innermost gimbal can be thought of as a 'stable platform' on which are mounted the gyros and accelerometers (although, in practice, it looks like anything but a platform, being a miracle of mechanical packaging). The whole arrangement is generally called a 'gimballed platform'. Fig. 2 shows the interior workings of a Marconi FIN1000 inertial platform, which is used in virtually all the RAF's combat aircraft and many others worldwide, as well as in space launchers, missiles, land vehicles, etc.

The system described can thus measure the aircraft's position, velocity, acceleration, attitude, and heading. There are, of course, complications ...

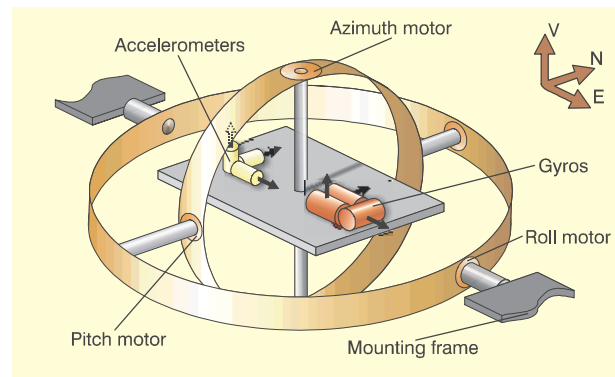

1 Gimballed inertial platform

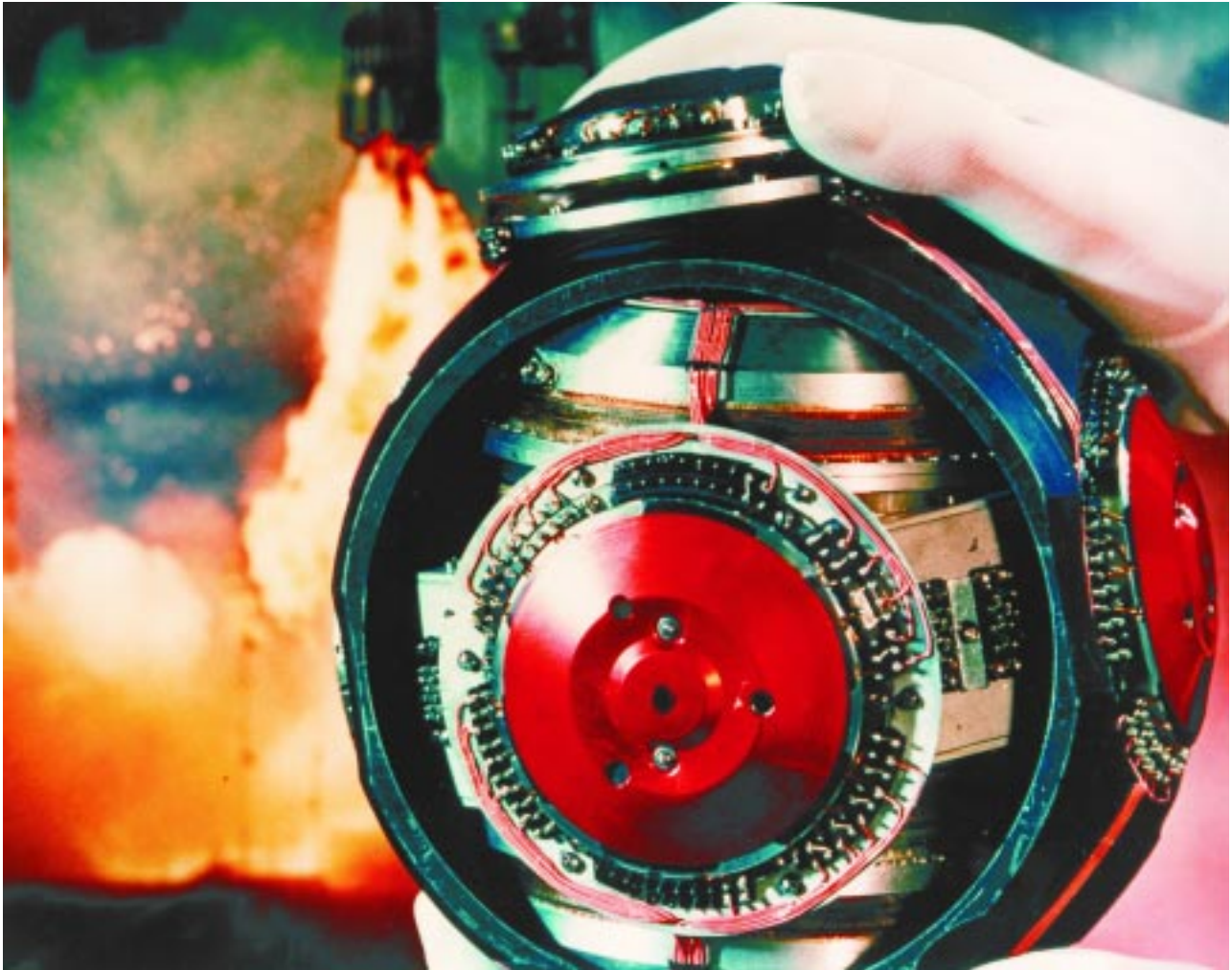

2 Gimbaled inertial platform

Schuler Tuning

The earth is not flat. As we move, close to the surface, we need to keep tilting the platform (with respect to inertial space) to keep the axes of the N and E accelerometers horizontal. To do this, we can use the gyro torquers, and feed them with a signal proportional to the N and E velocity. The angular torquing rate $\dot{\theta}$ that we apply is equal to v/R , where v is the linear velocity from the first integrator, and R is the radius of the earth (fig. 3).

Hence $\ddot{\theta} = a/R$, where a is the acceleration sensed by the accelerometer, which may be real acceleration, or a component of the gravitational field if the platform is not horizontal.

This is recognizable as the equation of motion of a simple undamped pendulum of length R , which has a period of oscillation of around 84 minutes, known as the Schuler period, after M. Schuler, who published a definitive text in 1923⁽⁴⁾.

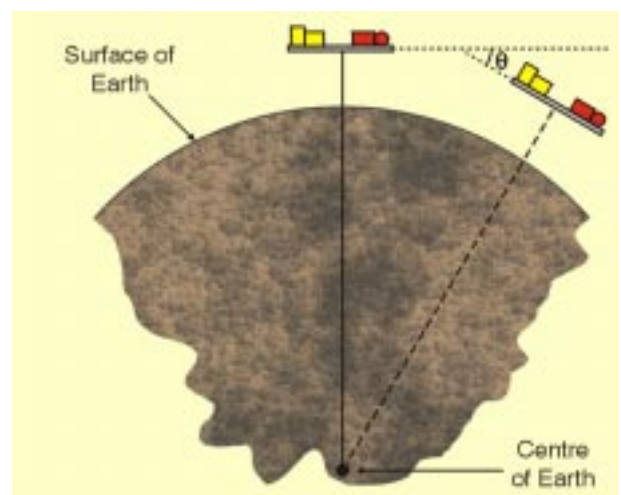

3 The 'Schuler Pendulum'

The block diagram of the system so far described is shown in fig. 4.

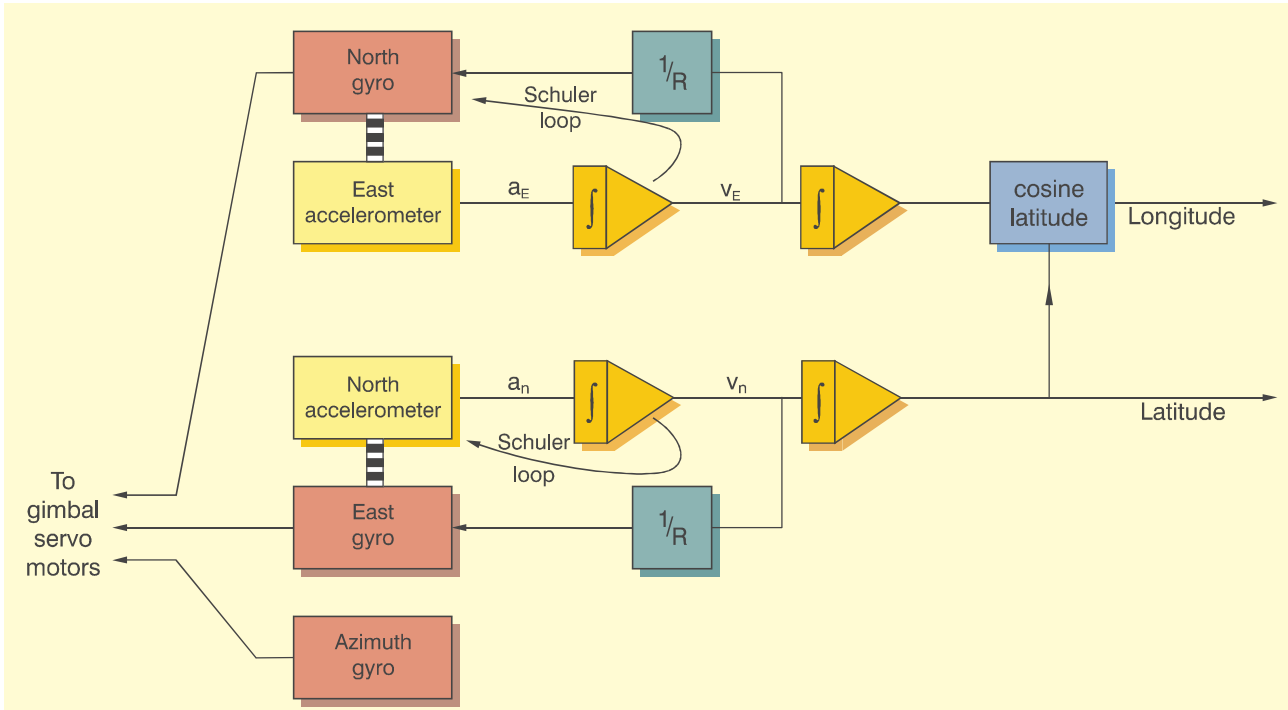

4 Simplified block diagram of inertial navigation system

Error Dynamics

To understand better the effects of errors in the system, some examples are given:

Initial Tilt Error

Assume the vehicle is stationary, and the platform is given an initial tilt of 100 microradians. This causes a 'horizontal' accelerometer to sense $100\mu g$, which, via the first integrator, torques the gyro in a direction so that the tilt reduces. The velocity and position signals oscillate at the Schuler frequency, as shown in fig. 5, with a peak position error of about 0.7 nautical miles[†]. This is equivalent to holding the bob of the pendulum off-centre, releasing it, and allowing it to swing.

Gyro Drift Error

Assume one of the gyros has a 'drift' error of 0.01deg/hour. This, via the servo, causes a tilt to build up, which oscillates at the Schuler frequency, again causing an oscillatory acceleration signal, and hence an oscillatory velocity error. In this case, however, the velocity error does not oscillate about a zero mean, and so the corresponding position error now consists of the Schuler oscillation superimposed on a ramp function

[†] 1 nautical mile (naut. mile) = 1852m

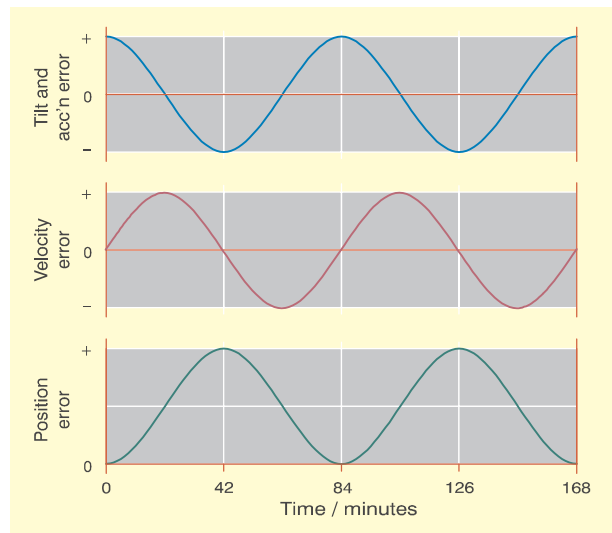

5 Effects of initial tilt error

(fig. 6). After one hour, the position error is about 0.7 nautical miles.

Azimuth Gyro Drift

This causes a different behaviour to that caused by drift in the 'horizontal' gyros. The gimbals rotate slowly about the vertical axis, thus the 'East' gyro begins to sense a small component of the earth's rotation. This in turn causes the 'East' servo to tilt the platform towards the North, causing an erroneous 'North' acceleration signal. The resulting North position error in this case is a Schuler oscillation, superimposed on a time-squared

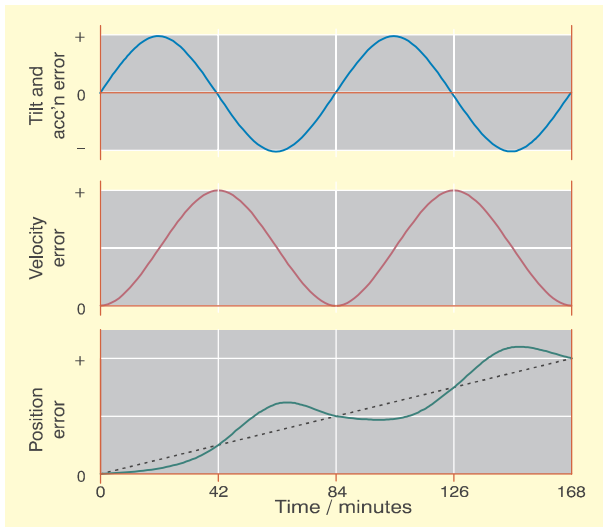

6 Effects of gyro drift error

function. For short durations, this effect is less sensitive than that of 'horizontal' gyro drift. It requires about 0.2deg/hour of azimuth gyro drift to produce a position error of 1 nautical mile after one hour – that is, a factor of 20 less sensitive.

Other Sources of Error

The above three examples give a flavour of the error dynamics. There are dozens of other sources of error, including instrument misalignments, scale factors, non-linearities. Many of these instrument errors vary each time you switch the system on – I.Ns. have good days and bad days. To characterize the performance of an I.N., you have to resort to statistics, and take the r.m.s. total error from an ensemble of many representative missions. A typical standard expected from a 'good' I.N. produces an error that increases with time (not in an entirely linear fashion), and reaches 0.6 miles after one hour (referred to as an 0.6naut. mile/hour system).

Further Complications

There are many other complications that result in a final block diagram much more complex than that shown in fig. 4. It isn't necessary to elaborate further here, but some examples include:

- Coriolis acceleration, caused by the earth's rotation,
- the effects of vertical motion (modifying the 'R' term),
- the ellipticity of the earth, and
- 'gimbal lock' in aerobatic manoeuvres.

Strapdown Systems

Gimballed I.Ns. can be very reliable, accurate, and good value for money. However, the gimbal arrangement is mechanically very complex. It contains delicate sliprings; the motors dissipate power, thus the instruments see a varying thermal environment as the gimbals move about; mechanical resonances are unavoidable. They can also be expensive to maintain – if a gyro or accelerometer needs to be replaced, the gimbal set has to be dismantled and, after replacing the instrument and rebuilding (in a surgically-clean environment), there are lengthy calibrations to be done. Testing inertial platforms is time-consuming – you can't hurry the Schuler period.

So from the early 1970s, the I.N. industry started contemplating an alternative, simpler arrangement. Why not get rid of the gimbals altogether – just 'strap down' the gyros and accelerometers onto the mounting frame? Use the gyros not as null-seekers, but as a means of measuring rotations in space, so that the system always knows which direction the accelerometer axis set is pointing in at any instant (fig. 7). In effect, we have a 'mathematical gimbal set', replacing the mechanical gimbals.

By the early 1970s gimbaled I.N. technology was fully mature, having evolved over 20 years. There were three problems standing in the way of developing a strapdown system.

Gyro Dynamic Range and Scale Factor

In a gimbaled system, gyros need to measure down to a few thousandths of a degree per hour (extremely difficult, but after 20 years' development, fully achievable). However, they had only to measure rotations up to a few tens of degrees per hour – a dynamic range of about 10^5 .

In a strapdown system, the same drift accuracy is needed, but it is also necessary to measure rotations within the full manoeuvre envelope of the aircraft – up to several hundreds of degrees per second. The dynamic range is thus four orders of magnitude greater.

Furthermore, the gyro scale factor has to be extremely accurate and linear. Rotations in three axes are not commutative. Tiny errors in scale factor accuracy can build up to big attitude errors. Scale factor accuracy needs to be a few parts per million at the most (compared to a few hundred parts per million tolerable for a gyro in a gimbaled system).

Processing

The 'attitude vector' computation, and the axis transformation, have to be carried out at very high

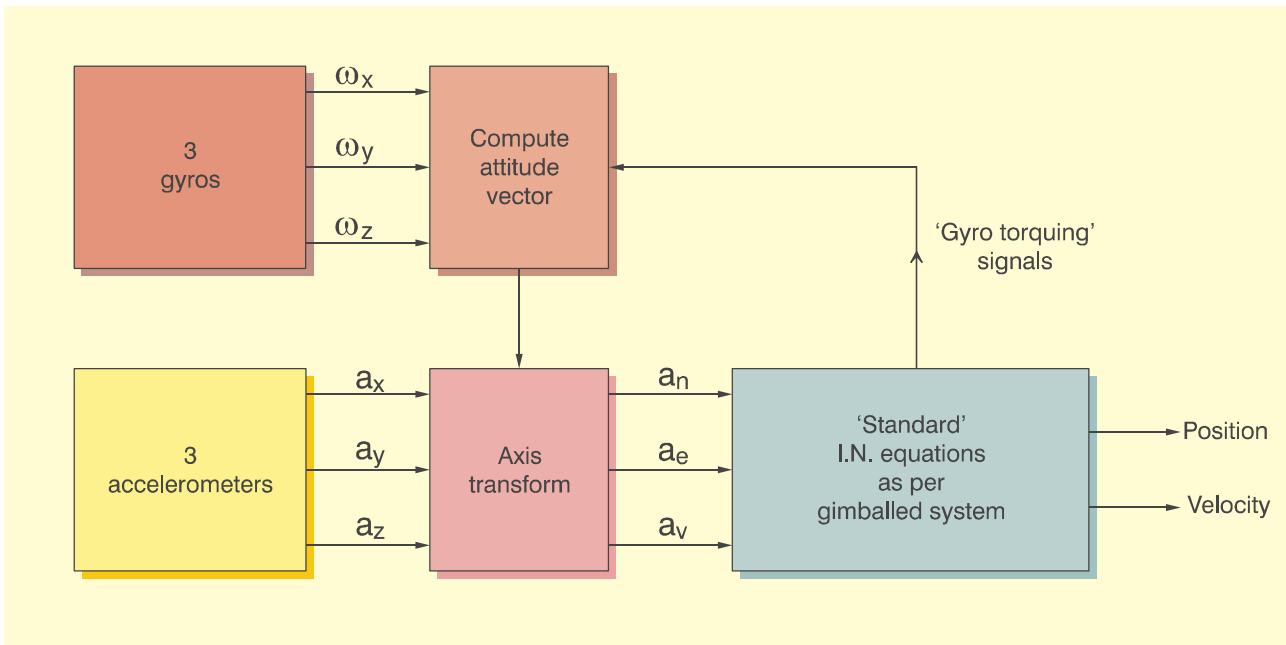

7 Strapdown inertial navigation unit block diagram

iteration rates. 2kHz is the current fashion (a combat aircraft can roll through about 2mrad in 0.5msec). In a gimballed system, the I.N. equations need to run at only 20-30Hz.

In the 1970s, the processing power for strapdown systems, in compact flyable computers, was just not available.

Accelerometers

For various complex reasons, the accelerometers need to be better (by smaller factors – about $\times 2$ to $\times 5$) than for gimballed systems, in terms of bandwidth, scale factor, and bias accuracy. This was less of a problem.

Strapdown Gyros

Throughout the 1970s, brave attempts were made to produce gyros that were man enough for strapdown systems capable of 0.5 – 1naut. mile/hour. In particular, two U.S. companies ‘nearly’ achieved it with spinning-wheel gyros – but not quite. To achieve low drift, the wheel needs a high angular momentum. For high torquing rates, this in turn needs high power in the torquer electromagnet – several hundred watts. This causes high thermal transients, which are difficult to compensate.

The real enabler for strapdown systems was the Ring Laser Gyro (RLG). This had been under development since the mid-60s, originally with the motivation of achieving better reliability than that of spinning-wheel gyros. An RLG has (almost) no moving parts. Fortuitously, it turned out that the

RLG has inherently an extremely good scale factor accuracy, typically about 5p.p.m., and furthermore dissipates the same (quite low) power, no matter what the rotation rate is.

It took about 18 years (from the mid 1960s to the early 1980s)⁽⁵⁾ for the RLG to achieve the maturity, economy, and produceability to enable it to be used on a large scale in production I.N. systems. By then, the ‘processing power’ limitation in computer technology had been removed, with the sheer passage of time (as it always will).

Interestingly enough, the ‘reliability’ advantage of RLGs has turned out to be a fallacy. Good spinning-wheel gyros today have mean time between failures (MTBFs) – in an aircraft environment – of tens of thousands of hours, and virtually no life-limiting wearout mechanisms. RLGs are not demonstrably better in either of these respects. In fact, it tends to be the reliability of the associated electronics that dominates an I.N. system’s MTBF. A modern strapdown RLG I.N. has an MTBF of 5000-10000 hours. The most recently-designed gimballed I.N.s (designed 10-12 years ago) have MTBFs of around 600 hours, with about ten times the number of electronic components.

Principles of the RLG

Any discussion of the RLG must include at least a brief introduction as to how it works (figs. 8 and 9).

The RLG body is a solid glass block, with three narrow tubes drilled in it. A mirror is placed at each corner, forming a triangular optical resonator path. The tubes are filled with a helium-neon mixture at low pressure. A high voltage (around 1kV) is

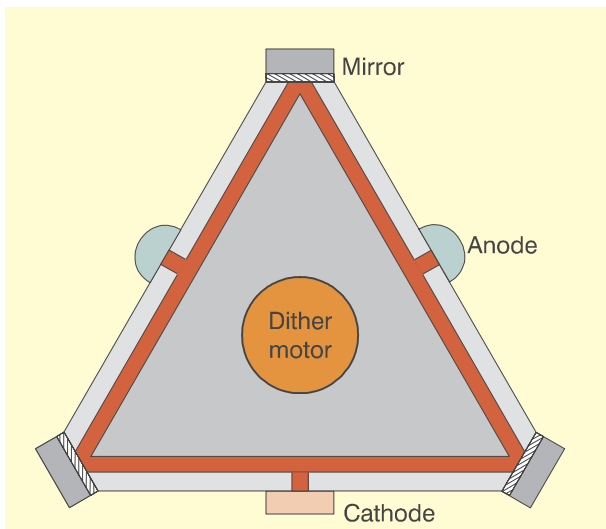

8 Ring laser gyroscope – schematic

applied between the cathode and the two anodes, causing a discharge (simply an expensive neon lamp). The discharge provides enough energy to

cause regenerative lasing action in the gas, with light beams circulating around the triangular resonator path. In fact, there are two lasers within the same cavity – one with a clockwise (CW) beam, the other counter-clockwise (CCW). When the gyro is at rest, the two beams have the same frequency (typically with a wavelength of 633 nanometres).

Now consider the block rotating in a CW direction. A photon in the CW beam, starting at the bottom left-hand mirror finds, after one traverse of the cavity, that the mirror has moved slightly further away. Thus it sees a slightly increased path length. Similarly, a photon in the CCW beam finds a shorter path length. The difference in path lengths causes a small difference in frequency. By making one of the mirrors partially-transmitting, samples of both beams can be extracted and the frequency difference measured. This is precisely proportional to the applied rotation rate.

A complication arises at very low rotation rates. The mirrors are not perfect and produce miniscule amounts of backscatter, which couples energy

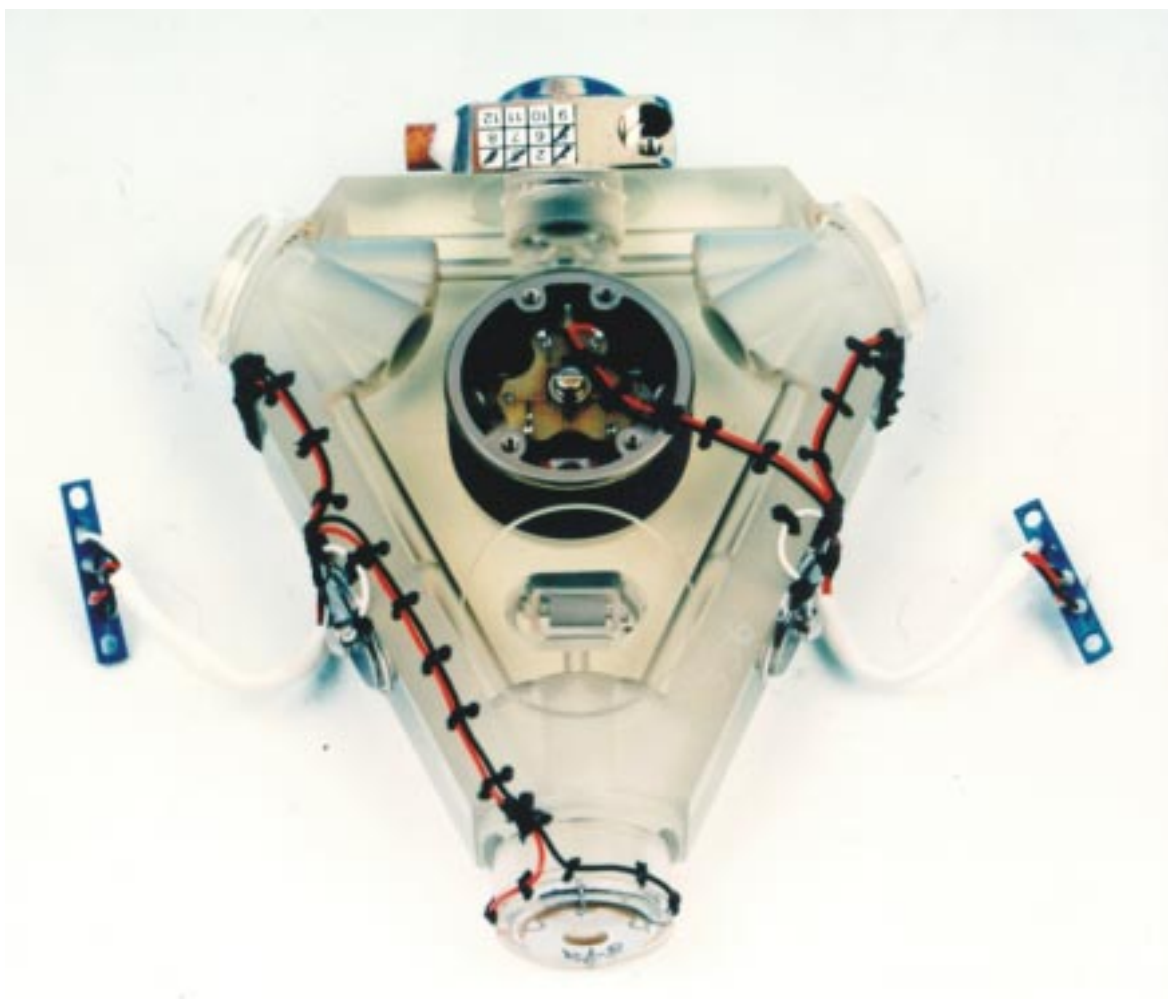

9 Photograph of a ring laser gyro

between the two beams. This coupling of energy between two very high-Q oscillators can cause the frequencies to lock together. To overcome this, the dither motor shown in fig. 8 applies a very small oscillatory rotation (about 1 arc-minute peak, at about 400Hz) to the entire block.

Modern Inertial Navigation

As mentioned, few if any high-accuracy gimbaled I.N.s have been designed within the last 10-12 years. There are still plenty of them about: if you fly in a Boeing 747 you may still be navigated by gimbaled, spinning-wheel-gyro I.N.s (three of them), although there are certainly more RLG I.N.s than gimbaled I.N.s in civil aircraft world-wide.

In Europe, gimbaled I.N.s still massively outnumber RLG I.N.s in military aircraft, although all new aircraft, and retrofits, have tended to specify RLG I.N.s over the last few years. In the USA, the numbers are probably closer, with the massive investment in re-equipping the F-16, F-18 and many other aircraft fleets.

The modern strapdown RLG I.N. is about $7 \times 7 \times 11$ inches ($178 \times 178 \times 279$ mm) in size, weighs about 10kg, with a power dissipation of about 50W. It costs some tens of £K. Typically, it contains about five circuit boards, including a processor equivalent to a 68040, 486, etc. It has a navigation performance of around 0.6naut. mile/hour in pure inertial mode, with an r.m.s. velocity accuracy of about 0.7m/sec, and an attitude accuracy of about 1mrad.

The size, cost and weight are roughly about 2-3 times better than those of the 'latest' gimbaled I.N.s, with about the same level of performance. Fig. 10 shows the Marconi FIN 3110 I.N., an example of the state-of-the-art in inertial navigation. Fig. 11 shows the instrument cluster, the heart of the system, which consists of three gyros and three accelerometers, mounted in a mechanical frame designed to mitigate the effects of vibration, shock, thermal transients and other environmental features that can make life difficult for precision instruments.

A new feature is that many I.N.s today contain an embedded GPS (Global Positioning System) receiver module. GPS and I.N. are ideal synergistic partners, as their error dynamics are totally different and uncorrelated.

The following are the main advantages:

- The integration with GPS solves the problem of 'calibrating' the instrument errors in a strapdown system. In a gimbaled system, the gimbals can be moved into different positions without removing it from



10 Marconi FIN3110 ring laser gyro inertial navigation unit

the aircraft, thus allowing the earth's rotation and gravitational field to calibrate each of the gyros and accelerometers. This cannot be done with a strapdown system.

- Similarly, the GPS provides a means of 'in-flight alignment', removing the need for the aircraft to be held stationary for up to 5 minutes while the I.N. 'gyrocompasses', prior to flight.
- The I.N. provides a seamless fill-in for GPS 'outages' resulting from jamming, obscuration caused by manoeuvring, etc.
- The I.N. provides a means of smoothing the noisy velocity outputs from the GPS, and a continuous high-bandwidth measurement of position and velocity.
- In a tightly-integrated system, the I.N. provides a means for narrowing the bandwidth of the GPS tracking loops, providing greater immunity to jamming.

Technology Milestones

It is worth pausing for a moment to look back at the significant technology 'leaps' in inertial navigation and to try to conjecture what the next milestones will be. Marconi's Navigation Systems group was originally (until 1989) part of the Ferranti Company, which had been involved with gyroscopic instruments since the early days of the 20th Century, and thus has had either a 'ringside seat' or a direct participation in the significant developments in this field throughout.

Marine gyrocompasses were in use at the end of the 19th century, although they were simply



11 *FIN3110 instrument cluster*

gyro-assisted magnetic compasses. In the early 20th century, stand-alone gyrocompasses were enabled by the introduction of damped Schuler loops.

In the 1940s, German developments advanced inertial instrument technology to the level required for missile guidance. There were still no 'Schuler-tuned' I.N.s, but the principles were established. Working closely with the Royal Aircraft Establishment (RAE), our Company's gyro developments in some cases incorporated features observed in the latest German instruments which RAE scientists had obtained.

The early 1950s saw the first Schuler-tuned I.N.s, developed by the Massachusetts Institute of Technology (MIT) Instrumentation Lab. (later the C. S. Draper Laboratory). This also included the development of the floated-rate integrating gyro – the first gyro capable of drift performance of around 0.01deg/hour. In the late 1950s we were producing inertial guidance systems for the UK's Blue Streak and Blue Steel missiles, using floated gyros and integrating accelerometers.

The mid-1960s saw a proliferation of I.N.s in high-performance combat aircraft. Also at this time, development of the dynamically-tuned gyro (DTG)

was started[†]. This is a 2-axis gyro configuration, that does not require flotation fluid or precise temperature control. It has some disadvantages to counter these advantages. It was not a significant enabler – although many US companies switched to DTGs, others in the USA (and in the UK, including ourselves) continued successfully with floated gyros.

Also in the mid-1960s, research on a high-accuracy 'Hemispherical Resonator' vibratory gyro (the HRG) and on the RLG was started by various companies in the USA. The HRG, despite decades of development, has never quite made serious inroads into the market, except in a few specialized applications. The RLG is a different matter. (In the UK, a Ministry of Defence-sponsored RLG prototype was built at Farnborough in 1967, with the participation of our company and others. However, after demonstrating that it worked as advertised, the Government lost interest for a further ten years).

In the 1970s, futile attempts were made to develop strapdown spinning-wheel-gyro I.N.s, as described earlier. However, I.N. companies, and their government patrons, had by then realized the potential of the RLG, and very large investments were made in the technology. A major breakthrough came with the selection of RLG I.N.s for Boeing's new 757. Strapdown systems at last became practicable. Our own development of RLGs and strapdown systems began in 1977, and has culminated in the FIN3110 system described earlier.

Nuclear magnetic resonance (NMR) gyros were also the subject of research in the 1970s. With hindsight, this has turned out to be simply a scientific curiosity, with no viable practical application.

A more promising 1970s development was the fibre-optic gyro (FOG)⁽⁶⁾. Unlike the RLG, which is self-resonating, the FOG is an interferometric optical device, where an external source injects coherent light in two opposite directions around an optical-fibre coil. The scale factor is not inherently as accurate or stable as that of the RLG.

The 1980s were the 'decade of the RLG'. Development of gimballed I.N.s was eventually supplanted by that of strapdown RLG systems. An example is the guidance system for the Ariane

satellite launch rocket. Since the mid-70s, we had been supplying gimballed platform systems for Ariane. Over 70 such systems were launched, with 100% success. However, by the 1980s it had become apparent that the guidance task could be performed with equal accuracy and reliability using RLG strapdown systems, with some savings in cost, weight and power consumption. We were contracted to develop an RLG system to replace the previous gimballed one and this has subsequently been used with equal success in the later Ariane Mk 4 launches.

GPS loomed on the horizon – would it supplant I.N. altogether? The answer turns out to be 'No' – considerations of integrity, both in civil and military aviation, imply that GPS becomes a partner rather than a successor. However, GPS has certainly supplanted I.N. in specialized markets such as inertial land surveying.

FOGR&D continued through the 1980s, but there were still no signs of it being able to achieve the performance required for high-accuracy I.N. It did, however, demonstrate the potential to supplant lower-performance gyros in lower-accuracy systems which are primarily Attitude/Heading Reference systems (AHRS), rather than stand-alone navigators.

The mechanical dither motor in RLGs was seen as an 'improvement opportunity'. Development of an alternative RLG configuration, the 'multi-oscillator', had been an attractive possibility and was pursued by several companies throughout the 1970s. The multi-oscillator is an RLG variety that dispenses with the mechanical dither by separating the frequencies of the CW and CCW beams using non-reciprocal elements in the optical path. It has proved very difficult and, by the end of the 1980s, only one company was having any success in producing instruments of this type.

I suspect that any advantages of the multi-oscillator technique are balanced by corresponding difficulties and, like the DTG versus the floated gyro, the overall effect on the evolution of I.N. technology will not be too significant. Our own RLGs continue to use mechanical dither, which is robust and reliable.

In the late 1980s, GPS became operational. There were significant advances in navigation integration, spurred on by GPS.

The end of the cold war removed the impetus from strategic missile guidance, which had until then been the prime 'money no object' driver for technology advances. Strategic missiles (and the submarines that carry them) need, for certain parameters, about ten times the accuracy of

[†] Although popularly believed to have been invented in the USA circa 1964, the principles of the DTG were in fact devised and patented in the UK by two Royal Aircraft Establishment scientists during World War II; however, the technology to realize it was not then available.

aircraft I.N. components – but they could afford about ten times the price!

From now on, I.N. development will be driven primarily by the needs of civil and military aircraft navigation, and by the growing market for military land vehicle applications.

In the 1990s, there have been no significant changes so far. The size of a 'typical' RLG I.N. has shrunk from the 'ENAC77/SNU84' form factor (about 22kg weight) to the current 'EGI' (about 10kg) described above, and most military I.N.s now include an embedded GPS receiver.

There is still no sign of a 0.6naut. mile/hour FOG I.N., although some vendors are beginning to make predictions that it will be achievable.

Forecast for the Future

No major evolutionary steps are foreseen for at least the next decade. There will nevertheless be some continuous improvements. Electronics (and particularly processing power) will evolve to the stage where the electronics becomes an insignificant part of an I.N.'s cost, size, weight and power. RLGs will continue to shrink (slightly), and in 10 years' time the 0.6naut. mile/hour I.N. will occupy 200cu. inches [$3.3 \times 10^{-3} \text{m}^3$] (rather than the current 500 [$8.2 \times 10^{-3} \text{m}^3$]). Cost should come down by a factor of two, also.

There would seem to be no drive towards higher performance. 0.6naut. mile/hour is adequate for all foreseeable aircraft applications, given that aircraft I.N.s will almost invariably be integrated with GPS, or other sources. In military land vehicles (a growing market for inertial navigation), the I.N. is commonly integrated with an odometer. As with GPS, this partnership provides excellent synergy.

We can already see an increasing proliferation of lower-performance I.N.s, or rather Inertial Sensing systems. If the I.N. is primarily acting as a fill-in for GPS outages, a lower performance will be tolerable in many cases. Systems will be able to use gyros around 0.1 to 1deg/hour, rather than 0.002 to 0.01deg/hour. For this reason, the FOG will come into its own, being cheaper to manufacture than the RLG.

Electro-optic and radar sensors on military aircraft require gyroscopic stabilization, local to the sensor (aircraft bend, by up to half a degree or more). The author can foresee the navigation (and flight control sensor) functions being satisfied by several small, low-cost, strapdown clusters containing 1deg/hour FOGs and 1mg accelerometers, slaved to each other and to the 'integrated navigation computation', and distributed around the airframe. There may still be a need for a

high-accuracy I.N. somewhere in the aircraft, if there is a need to assume that GPS will be unusable for high proportions of the mission, but within a decade numbers of high-accuracy I.N.s may decline to about half the current level, for new applications.

Land vehicle applications are providing some novel changes of emphasis. In many military land vehicles, the I.N. is there primarily to provide precision pointing of guns or other weapons – the provision of accurate navigation is simply an added bonus. However, there is an exploding market for automatic navigation systems in private cars and commercial vehicles. These systems primarily use GPS, RF beacons, odometer, map correlation, or some combination of these, as the primary sensor. However, some such systems also include gyroscopes to provide greater accuracy during turns, and gyroscopes and accelerometers are beginning to feature to an increasing extent. Is this 'inertial navigation'? Not yet, but it exemplifies the main principle of modern navigation – take data from as many different sources as is economically practicable, and combine them in the best way possible. The combination algorithms used owe their ancestry to the filtering techniques used to combine inertial data with radio aids, air data and visual fixes.

We can thus make a final forecast: Inertial Navigation (as a pure, stand-alone technique), may ultimately disappear – however, integrated (multi-source) navigation systems will continue to increase in sophistication, and will continue to require inertial data as an essential ingredient.

Acknowledgement

This article is based on a paper that was first presented at the IEE Workshop on Airborne Navigation Systems, held at Savoy Place, London, on 21st February 1997; the IEE's co-operation is gratefully acknowledged.

References

- 1 PARVIN, R.H., 'Inertial Navigation', Van Nostrand, 1962.
- 2 STELER, B. and WINTER, H., 'Gyroscopic Instruments and their Application to Flight Testing', AGARDograph AG-160 vol.15, NATO/AGARD, 1982.
- 3 SMITH, S.G., 'Developments in inertial navigation', *J. of Navigation*, **39**, p. 401-414, Sept 1986.
- 4 SCHULER, M., 'Die Störung von Pendel und Kreisellapparaten durch die Beschleunigung des Fahrzeuges', *Physikalische Zeitschrift*, **24**, 16, 1923.
- 5 MACKENZIE, D., 'From the luminiferous ether to the Boeing 757: a history of the laser gyroscope', *Technology and Culture*, **34**, p. 475-515, 1993.
- 6 LAWRENCE, A., 'Modern Inertial Technology', Springer-Verlag, 1993.