

*Requirements*

# Cargo Container Transfer Requirements for the Mobile Offshore Base

---

Submitted By:

**Intelligent Systems Division  
National Institute of Standards and Technology  
Gaithersburg, Maryland 20899**

To:

**Office of Naval Research (ONR)  
800 N. Quincy St.  
Arlington, VA 22217-5666**

---

## ADMINISTRATIVE INFORMATION

---

### Responsible Person / Organization

---

**Gene M. Remmers, Code 334**  
Office of Naval Research (ONR)  
800 N. Quincy St.  
Arlington, VA 22217-5666

### Performing Organization

---

National Institute of Standards and Technology  
Intelligent Systems Division  
Building 220/ Office B-127  
Gaithersburg, MD 20899

### Point of Contact

---

**Mr. Roger Bostelman**

Phone: 301-975-3426  
Email: rbostelman@nist.gov

### Principal Investigators

---

**Mr. Ken Goodwin**

Phone: 301-975-3421  
Email: kgoodwin@nist.gov

**Mr. Roger Bostelman**

Phone: 301-975-3426  
Email: rbostelman@nist.gov

**TABLE OF CONTENTS**

---

<b>PURPOSE .....</b>	<b>3</b>
<b>MOB MISSIONS AND CONCEPTS OF OPERATION .....</b>	<b>4</b>
<b>SCOPE .....</b>	<b>5</b>
<b>ASSUMPTIONS .....</b>	<b>6</b>
<b>REQUIREMENTS .....</b>	<b>8</b>
Reach.....	8
Height.....	11
Crane Lift Capacity.....	14
Airspace Restrictions .....	14
Structural Crane Support.....	15
Operational Sea States.....	16
Lighter Loading.....	18
<b>DESIRABLE FEATURES .....</b>	<b>19</b>
Crane Throughput .....	19
Cargo Placement, Storage, and Retrieval.....	20
Stowage .....	21
<b>RECOMMENDED ACTION ITEMS AND EFFORTS .....</b>	<b>23</b>
<b>REFERENCES .....</b>	<b>25</b>

## **PURPOSE**

---

The purpose of this requirements statement is to serve as a guideline to Mobile Offshore Base (MOB) concept developers, so that cargo handling requirements are fully considered and addressed in the development of concepts and preliminary designs. These requirements have evolved from National Institute of Standards and Technology (NIST) laboratory work to develop cargo crane concepts for the MOB program, as well as from several preliminary concepts of the MOB concept developers under contract to the Defense Advanced Research Projects Agency (DARPA) and the Office of Naval Research (ONR). [1]

## **MOB MISSIONS AND CONCEPTS OF OPERATION**

---

There are a wide variety of possible missions for the MOB. The Mission Needs Statement calls for a broad range of capabilities, including: support of loading and unloading of naval craft, including roll-on/roll-off (RO/RO), large medium-speed RO/RO (LMSR), oiler, container, multi-purpose, logistics support vehicle (LSV), landing craft utility (LCU), landing craft mechanized (LCM), and landing craft air cushion (LCAC) vessels. [2]

Concepts of operations, under development by Syntek for the Office of Naval Research, include: Special Operations Force, Logistics, Prepositioning, and Operation Maneuver from the Sea (OMFTS), and Tactical Aviation. [3]

Development of the MOB could meet many of the long recognized needs for Joint Logistics Over the Shore (JLOTS) operations. [4], [5]

Viewed in conjunction with the proposed next generation aircraft carrier, CVX, the MOB could also serve as a tender, tanker, aircraft repair facility, unmanned air vehicle (UAV) operations and support base, or Vertical Launch System (VLS) replenishment base. The MOB cranes could even be used to reconfigure the CVX by changing out modules. [6]

## **SCOPE**

---

**The scope of this requirements statement will include the lift on/lift off (LO/LO) transfer of cargo that is normally handled by cranes.**

This will include containers and break bulk cargo, such as tanks and causeway sections. Emphasis will be primarily upon the transfer of containers between the MOB and cargo container ships, landing craft, and lighters.

This report will not deal with loading and unloading cargo brought by aircraft to the flight deck. Such cargo will be handled by specialized forklifts, rolling equipment, ramps, and elevators. Also, it will not address Roll On/Roll Off (RO/RO) cargo (such as trucks), nor bulk liquids transfer.

---

**ASSUMPTIONS**

---

**Cranes will be used to perform LO/LO operations**

Military Sealift Command and commercial cargo container ships will deliver containers to the MOB. Although other container transfer mechanisms have been proposed, the current design of container ships requires a capability to retrieve containers from cells deep in the ship. Ships are loaded at ports by port cranes because cranes are the most cost effective mechanism available.

**Cranes will unload cargo from container ships onto a platform that is extended from the lower cargo deck of the MOB.**

On this loading platform, similar to a loading dock of a warehouse, there will be container transfer mechanisms (possibly rails and carts, monorails or automatic guided vehicles) that move containers along the side and into and out of the MOB as shown in Figure 1.

---

**FIGURE 1.**

Load Shuttle Platform outside of MOB

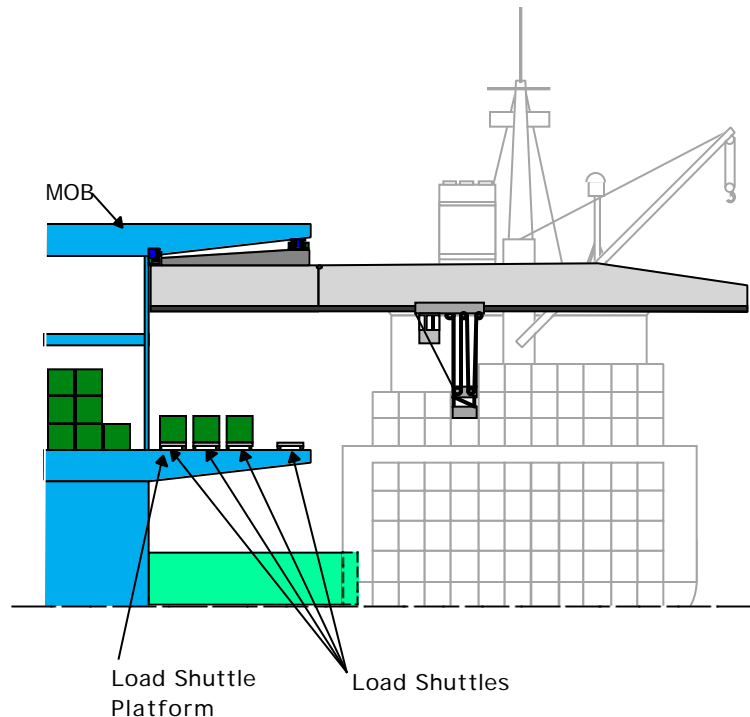

**Cost, power, reliability and other design factors will be considered later in the detailed design stage.**

Cost, power, reliability, maintenance, etc. will be important factors in the selection and design of cranes for the MOB. These factors will be considered in conjunction with each crane's capability to meet mission-derived performance throughput requirements. Power requirements for crane operations are a direct function of the throughput and motion compensation design requirements. Preliminary examination of several crane designs indicates that crane power requirements must be addressed but will not be a major driver of MOB power requirements.



## **REQUIREMENTS**

---

The following requirements are generic cargo handling system performance and design requirements, developed before specific mission scenarios are developed.

Two types of requirements are discussed below. The first set are similar to what a port crane needs for loading container ships. They include crane reach, height, and lift capacity.

The second set of requirements are specific to the MOB because of its special operating characteristics. The requirements include operating without intruding into aircraft operations space, structural support on the side of a MOB, operating in high sea states, and lighter loading.

### **Reach**

---

**Cranes must be able to reach the far side of the largest container ships currently in use (Panamax class ships).**

This requires almost a 50 m reach when fenders are considered. The reach required will depend upon the size of the container ships used, many of which are not Panamax size. However we assume that Panamax class ships will be used at times to support the MOB and the cranes must provide reach adequate to span them. The distance from the outer edge of the MOB to the ship wall berthed against the MOB will depend upon the design of the MOB and the amount of fendering required to keep the container ship clear of the flight deck overhang (if any). For the McDermott design, the distance between the MOB and a ship is about 3 m (e.g. com-

pressed fender) to 4.5 m (e.g., non-compressed fender). Figure 2 shows a Panamax ship berthed against the MOB with a compressed fender.

**FIGURE 2.** Cut-away view of a Panamax ship berthed against the MOB with a compressed fender

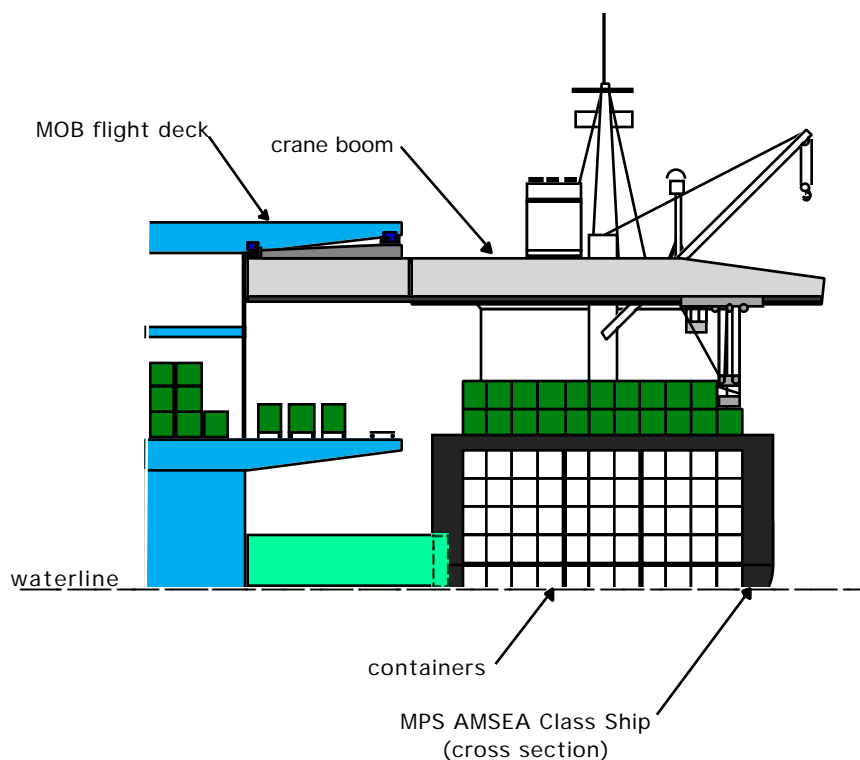

**Cranes must access container cells at various positions along the length of container ships.**

Fixed cranes would not be able to reach many cells of container ships moored alongside the MOB without warping the ship along the MOB. While moving the ship is technically possible, it is difficult and time consuming. Port cranes typically move on rails along the length of container ships. Similarly, it will be necessary for MOB cranes to move along the length of container ships (see figure 3).

However, if a container ship is longer than a MOB section, it may be necessary to warp the ship so that cranes can reach more cells. Some preliminary studies have shown that mooring lines can withstand the dynamic loads of container ships moored to the MOB in sea state 4. [7]

However, no designs have yet been developed for automatically warping container ships to move them along the MOB.

FIGURE 3. MOB top view showing crane traversal along MOB edge.

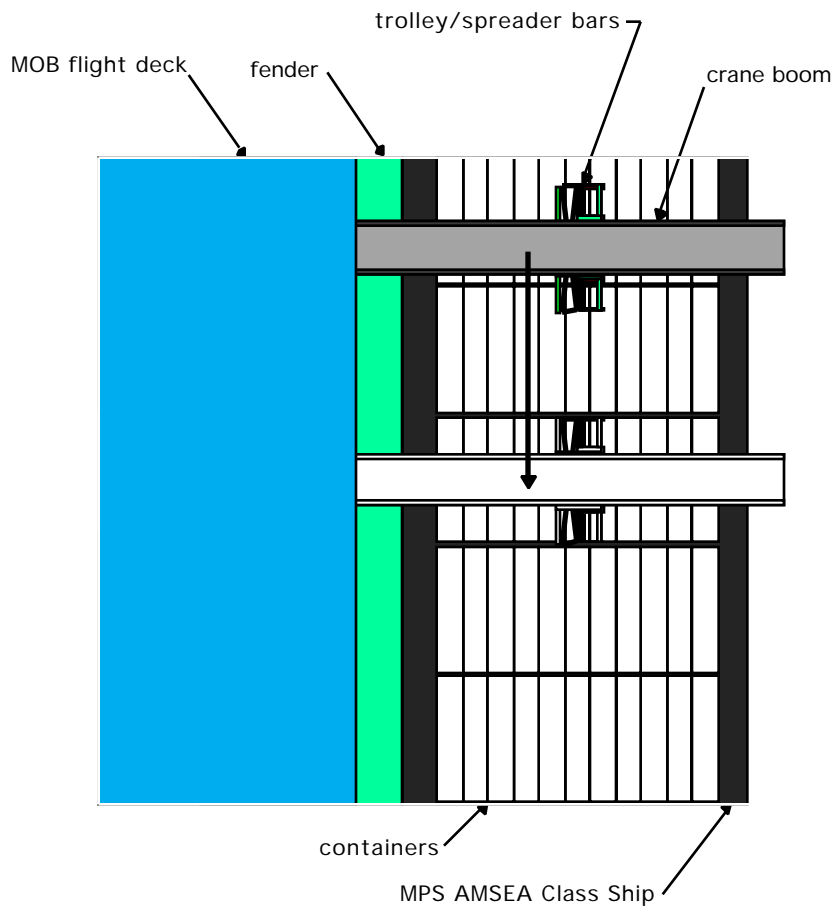

## Height

**Cranes must clear the superstructure of the ship and all shipboard obstacles.**

This means that the crane booms must be luffed or hinged so that they can be raised while container ships are docking (see Figure 4).

**FIGURE 4.** Crane boom being luffed to clear shipboard obstacles (units are in meters).

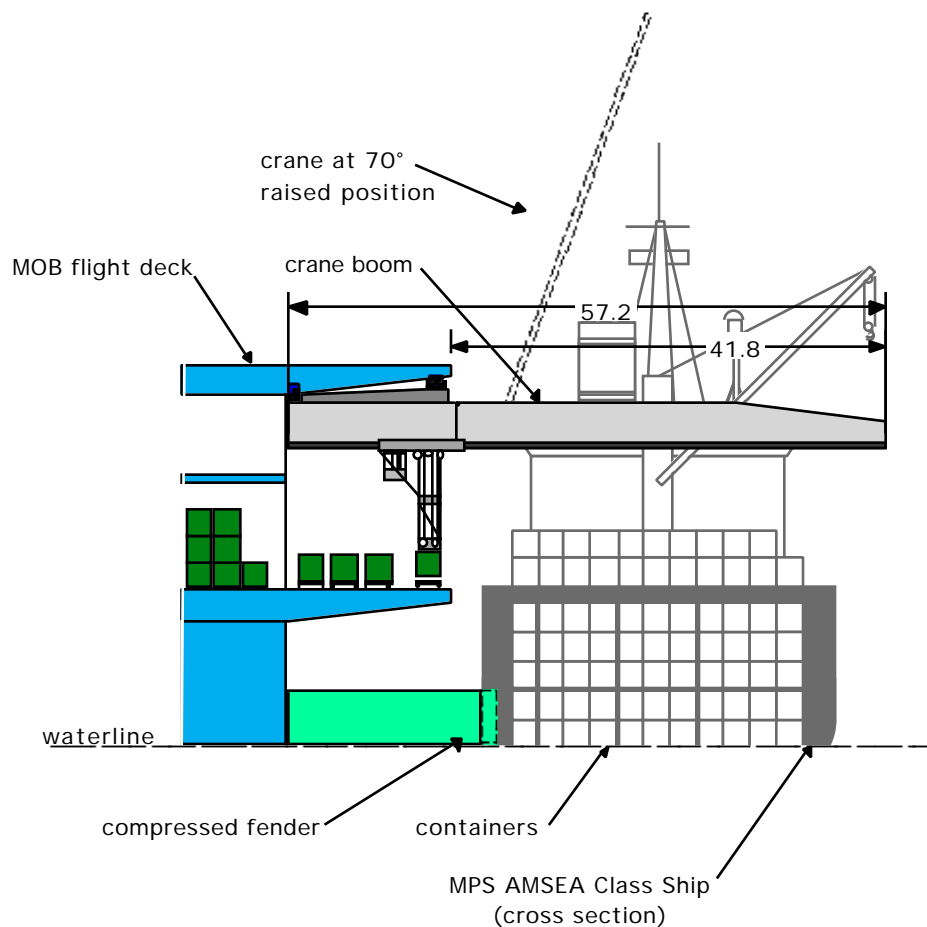

**The crane must have sufficient hook height to handle normal shipboard stacking of containers.**

For the Mc Dermott design, shown in Figure 5, the MOB flight deck will only be 36.5 m above the waterline during typical operations. The top container on a large, fully loaded container ship may sit 23.2 m or more

above the waterline (not considering vertical wave motion). This leaves only 13.3 m (= 36.5 m - 23.2 m) from the MOB flight deck to the top of the highest container. This means that the crane boom must be thin vertically to allow the highest possible hook height.

**FIGURE 5.** Rail crane height (in meters) restrictions for large ships (MPS AMSEA Class ship)

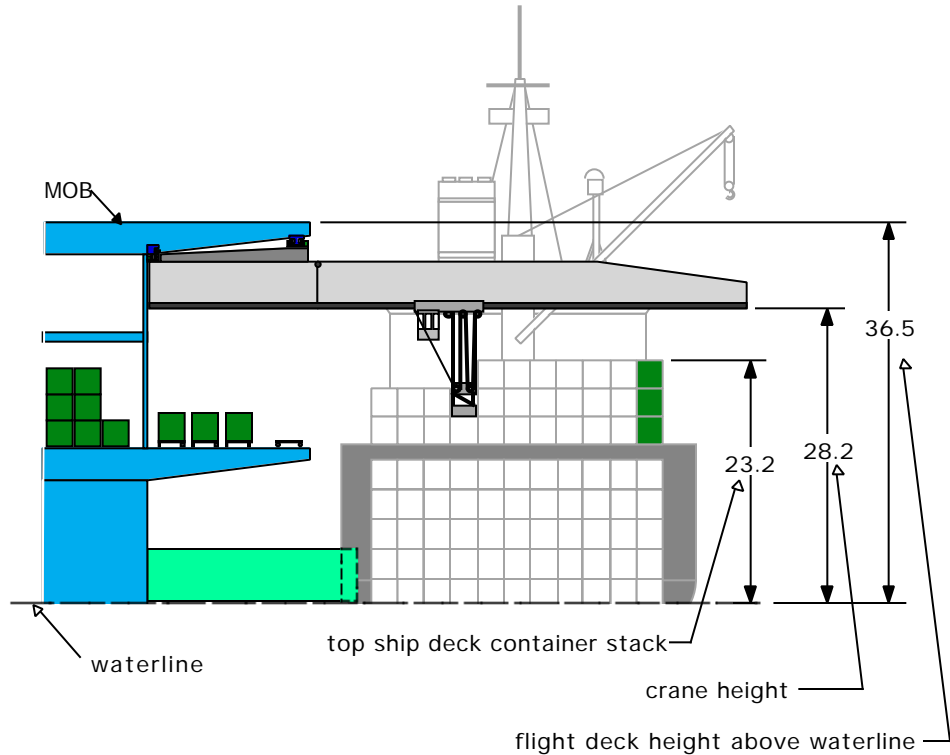

Minimum crane hook height is approximated at 25.8 m above the waterline (see Figure 6). This allows retrieval of cargo containers stacked only 2 high or less on the top deck of an MPS AMSEA Class Ship (see Figure 7).

To unload containers that are stacked 3 high on this ship, the crane must retrieve the top containers in sequence from closest to farthest from the MOB. This is assumed to be an acceptable operation constraint since an additional 2.5 m hook height would be required to lift a container over the top stacked container.

Container ships often carry containers stacked six or seven levels above the deck. To load, or unload, containers stacked higher than three levels, the MOB would have to be ballasted up to a higher level. Or an alternative crane design, such as a luffing boom crane, would be required.

**FIGURE 6.** Minimum Hook Height (in meters) for the Crane

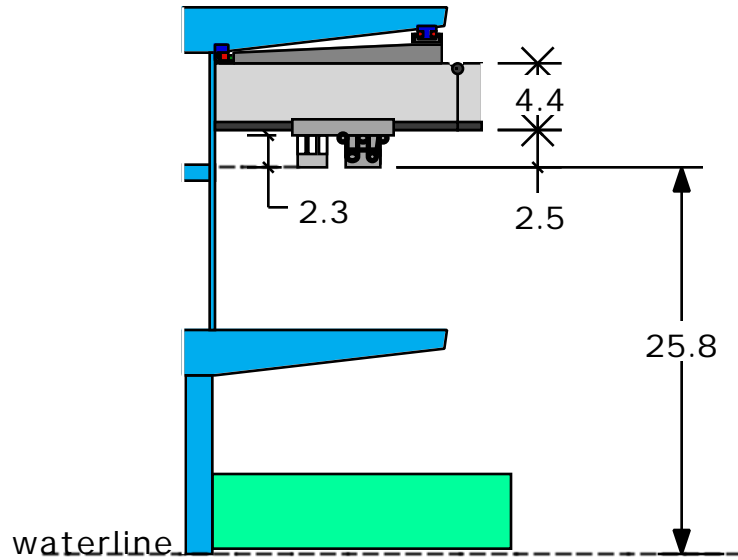

**FIGURE 7.** Crane Clearance (in meters) over Containers Stacked on an MPS AMS

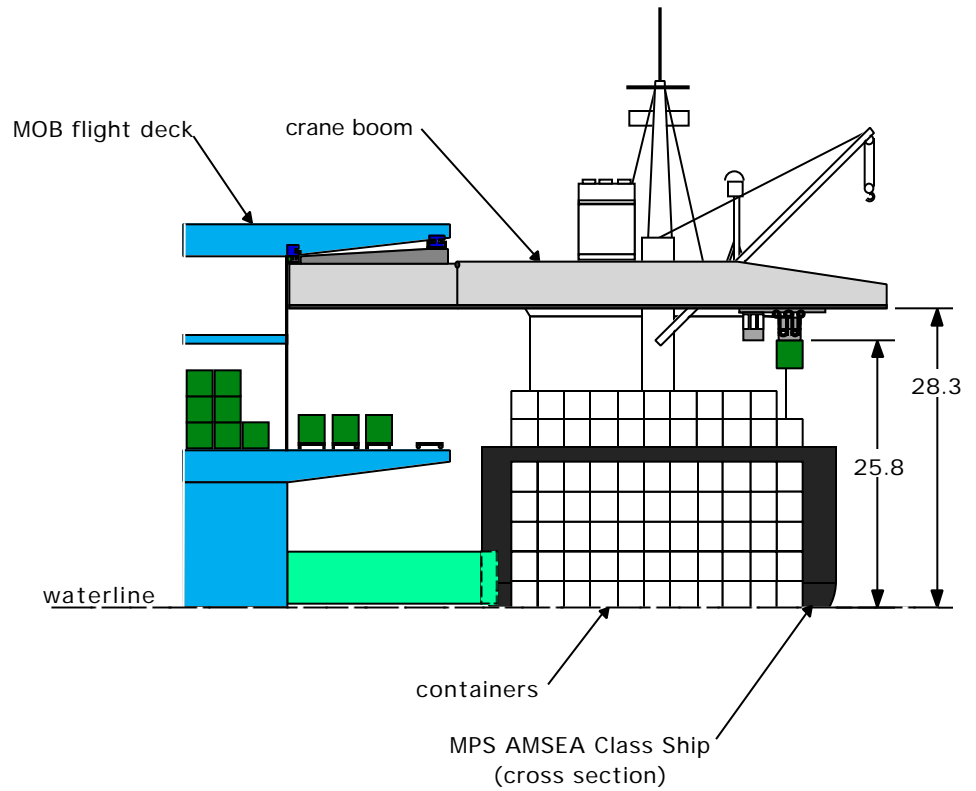

## **Crane Lift Capacity**

---

**Cranes must lift 23 tonne (25 long tons) containers from the far beam of Panamax class ships.**

Cargo is mainly containerized in 6 m to 16 m long x 2.5 m wide x 2.5 m high (20' to 52' long x 8' wide x 8.5' high) standard ISO containers.

LO/LO operations may also include break bulk and palletized cargo. Estimated maximum cargo weight positioned at a distance of 40 m (130') from the MOB edge is 23 tonnes (25 long tons).

**Cranes should be capable of lifting break bulk cargo, vehicles, and barge sections.**

This will provide lift of a 70 tonne tank at the center of a Panamax class ship (22 m) and lift of a 102 tonne causeway section at the near side of a ship (11 m).

**Cranes may be required to lift disabled RO/RO vehicles from ramps.**

In the event that RO/RO vehicles or other equipment becomes immobilized, cranes may be required to remove such items (up to the maximum crane lift capacity) from ramps to continue cargo retrieval/loading operations.

## **Airspace Restrictions**

---

**Cranes should not interfere with airspace above the flight deck.**

Cranes must not protrude into the airspace directly above the flight deck during air operations (see Figure 8). The vertical support tower that is commonly used to support and luff typical port rail cranes is not feasible for the MOB, at least not on both sides of the flight deck. It might be feasible on one side where there are air control towers.

However, there are examples of low profile rolling boom cranes currently being used in ports. These low profile booms suggest a similar rail crane design. They have larger rail cross sections than the high profile cranes because they must support the weight of the boom and cargo as a cantilevered load.

**Cranes should only rarely protrude above the plane of the flight deck.**

Air operations may require parking of aircraft with wings or tails overhanging the edge of the flight deck. Figure 8 shows "potential aircraft parking" extending 12 m beyond the MOB edge. This would interfere

with luffing crane booms or their longitudinal movement along the length of container ships during crane operations. For larger aircraft, such as the C-17 transport, takeoffs and landings may be made with one wingtip beyond the edge of the flight deck. The degree of interference between aircraft operations and crane operations depends upon the aircraft employed and the width of the flight deck. In some flight operations, it may be necessary to suspend crane operations on one side of the MOB.

**FIGURE 8.** Assumed Restricted Airspace Over the MOB Flight Deck

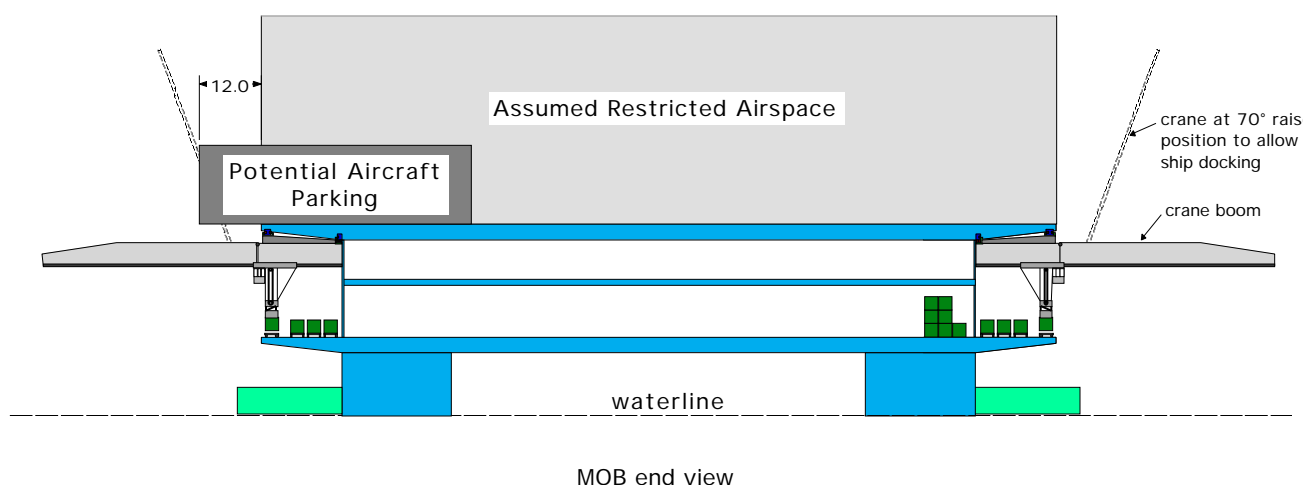

### Structural Crane Support

**The MOB structure should support cranes mounted on the side of the MOB.**

To avoid interference with aircraft operations above the flight deck, cranes must mount on the side of the MOB (see example in Figure 9). Therefore, the MOB structure must provide hardpoints which can support the load of the crane boom, the crane trolley, and a variety of cargos that are lifted at specified reaches. NIST has serious concerns about the forces that a fully loaded rail crane would exert on the MOB. A fully loaded luffing boom crane would generate much lower forces on the MOB than a rail crane, but would require the lowest deck to extend out beyond the flight deck. Some current MOB designs do not provide this feature.



FIGURE 9. Crane boom attachment to the MOB showing traversing rails and support structure.

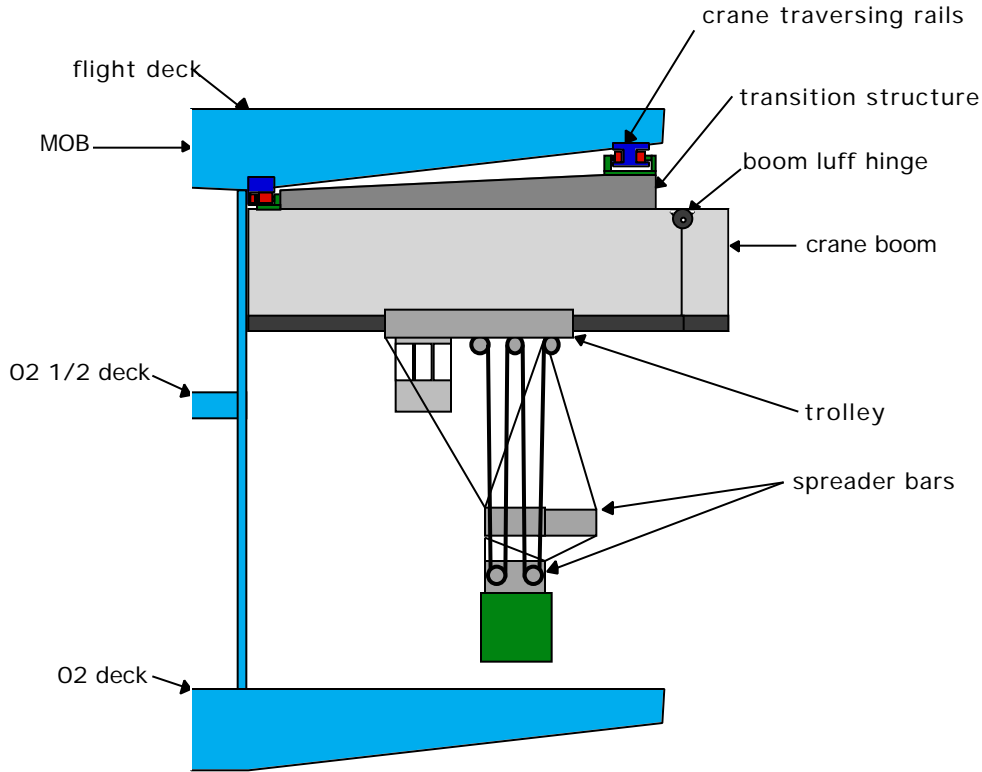

### Operational Sea States

**The MOB must be able to perform lift-on and lift-off (LO/LO) operations under weather conditions up to sea state 3, and preferably in sea state 4.**

The Mission Need Statement For the Mobile Offshore Base (MOB) calls for an operational capability in sea state 3. [2] It would be highly desirable to conduct cargo handling operations in sea state 4 because in some areas of interest this would allow operations a greater portion of the time. The maximum operational sea state in which cargo loading or unloading operations are to be performed is estimated at sea state 4, and these would be done only with large cargo container ships, since lighters would not be able to operate in sea state 4. We assume then that a reasonable design goal for cranes is to be able to perform lift-on and lift-off (LO/LO) operations under sea state conditions up to sea state 4.

**The MOB must have a capability of docking and mooring container ships.**

Container ships usually do not have sufficient dynamic positioning capability to dock with a MOB without assistance. In harbors, container ships are assisted by tugs. It will be necessary for the MOB to have its own tugs, or some automated docking system to achieve docking and mooring.

**The MOB crane must compensate for longitudinal, lateral, and vertical ship motions relative to the MOB in high seas**

Maximum motions for a Tactical Auxiliary Crane Ship (T-ACS) 4 relative to the MOB in sea state 4 are estimated to be: [8]

	<u>Displacement</u>	<u>Acceleration</u>
Longitudinal:	0.51 m (1.67 ft)	0.94 g x 100
Lateral:	1.12 m (3.69 ft)	2.16 g x 100
Vertical:	1.12 m (3.66 ft)	3.21 g x 100

Shipboard cargo motion compensation could be achieved by using automated rigging control as with the NIST RoboCrane technology. [9] This advanced technology would allow crane operators to retrieve cargo rapidly, even while at high sea states, by using an Intelligent Spreader Bar, with sensors and computer-assisted control that follows the cargo motion. [10]

## **Lighter Loading**

---

### **Loading containers from the MOB to lighters will be necessary.**

The U. S. Marine Corps vision of Operational Maneuver from the Sea (OMFTS), if implemented, would eliminate the need for displacement hull lighterage by bypassing the beach and moving cargo using aircraft from the seabase. [11]

However, the Army will continue to require lighterage. The larger Army lighterage (LSV, LCU2000) are most likely to be used for lighterage operations from the MOB. The proposed Joint Modular Lighter System (JMLS) will be designed to have a sea state 3 operating capability.[12] Smaller lighters could potentially be used, depending upon how far off-shore the MOB is located and weather conditions.

Motions of smaller ships at sea state 4 are expected to be considerably larger than motions of container ships. Wave motion compensation will require more horsepower because the smaller ships have greater relative motion than larger vessels.

It may be feasible for the MOB to replenish the Vertical Launch System (VLS) of AEGIS Class Cruiser (DDG 51) ships, a capability that does not currently exist in the fleet.[6]

---

## DESIRABLE FEATURES

---

Several desirable but not required features have been derived from preliminary design studies, model building, simulation and design development, as well as by concept developers Brown and Root and McDermott.

### Crane Throughput

---

**Operational cargo container throughput requirements are mission dependent, but could be set as high as 30 containers per hour per crane.**

Different organizations have estimated desired crane throughput rates in a variety of ways. The following cargo retrieval rate estimates represent different views of what may be required of a MOB.

- The current Naval Surface Warfare Center (NSWC) Advanced Crane Technology Demonstration goal is to unload 300 containers in one day. Current capabilities are to make one lift about every 7 min.
- Brown and Root estimated that it would take 120 hours to load 1720 containers, at a rate of 8 min per container, to support an Army Division.
- McDermott estimated that, with more cranes, it would take only 24 hours to load 720 containers, at a rate of 6 minutes per container to support a Marine Expeditionary Force.
- The Center for Naval Analyses has estimated that support of a Maritime Prepositioning Force for 2010 (MPF 2010) will require off loading of 4,166 containers. [13], [14]

Approximate maximum port crane throughput for containerized cargo is about 30 containers per hour. Although some port cranes are capable of unloading a maximum of 60 containers per hour, crane operation does not typically achieve this rate due to delays associated with ground transportation of cargo.

We believe that it is technically possible for MOB LO/LO operations to match port crane LO/LO rates of 2 min per container, under conditions of sea state 4. This can occur, provided that an advanced control system is developed and used in the MOB. If so, then a minimum of seven cranes,

operating 20 hours per day, would be required for a MOB to meet the most stringent off load requirement, for the MPF 2010, in one day.

### **Cargo Placement, Storage and Retrieval**

---

**The MOB should have the capability to store and retrieve individual containers, remove pallets, and repackage containers on demand.**

Although containerized cargo is simple and efficient for moving high volumes of cargo, Special Forces operations, OMFTS operations, and “marrying up” of MPF equipment with troops aboard the MOB will typically need cargo moved in smaller quantities, typically pallet sized loads. Therefore, an area for break-out , marshalling, and staging will be required. A capability to access multiple containers and load pallets and/or containers is needed.

**A cargo “buffer” area should allow convenient crane access and allow cargo transport along the MOB.**

As an example, in the current McDermott design, the internal decks of the MOB are recessed 15.5 m from the side edges of the MOB forming a covered external cargo handling area. Cranes would unload cargo from container ships to the covered cargo area that is attached to the lower deck of the MOB. On this platform, there would be conveyers or container shuttle mechanisms (possibly rails and carts) that would move containers along the side of the MOB as shown in Figure 1. The crane puts down and picks up containers from the outermost track (closest to the ship).

Two or more parallel tracks would be available so that containers or carts can pass while moving in opposite directions. This would permit simultaneous load and unload operations. There would be switching mechanisms that permit containers or carts to switch tracks. This enables a rapid and complex flow of traffic into and out of several doors to the storage areas.

**Cargo doors should be located at convenient points through which containers can be stored and retrieved.**

During LO/LO operations, a cargo transport system moves containers from the point where the crane puts them down and through one of several doors in the side of the MOB. These doors open to internal storage areas. Inside the MOB’s entrance doors, overhead cranes/container-movers pick up containers and move them to their storage locations.

**Stowage**

**The cargo cranes should be stowed for travel and excessive sea states.**

When in transit and during storms, the crane should be stowed, preferably in a location that provides for convenient servicing. The preferred method of stowing the crane is to move it to a home position where it can be retracted into a compartment that is internal to the MOB. Such an arrangement is illustrated in the McDermott design (see Figure 10). This option places the crane inside where it can be easily serviced.

**FIGURE 10.** Crane Stow by Retracting the Minimum Length (units shown are in meters) of Crane Boom on Rails and into the MOB

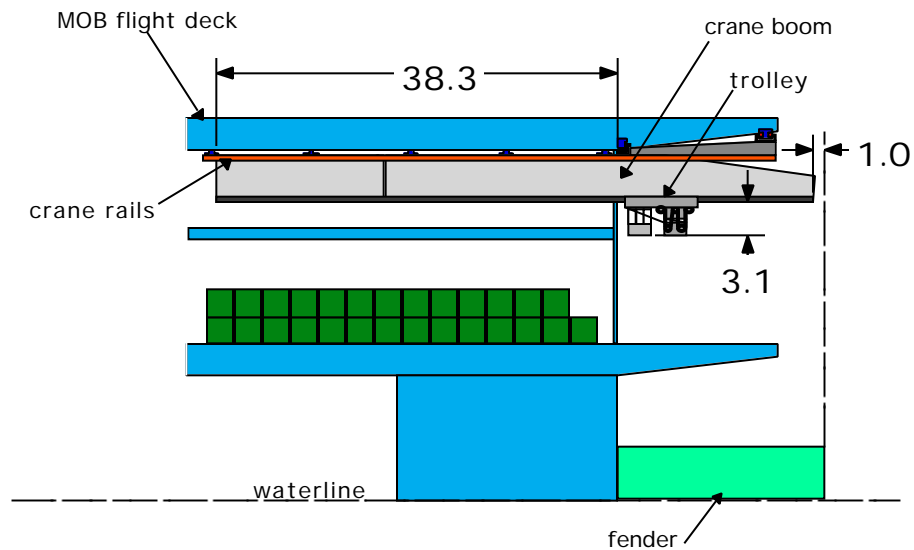

An alternative stowage concept is to rotate the crane into a position beside the MOB, as shown in Figure 11. This method can be used for either rail or luffing cranes.

FIGURE 11. Alternative Stowage concept. The top view of a luffing crane is shown.

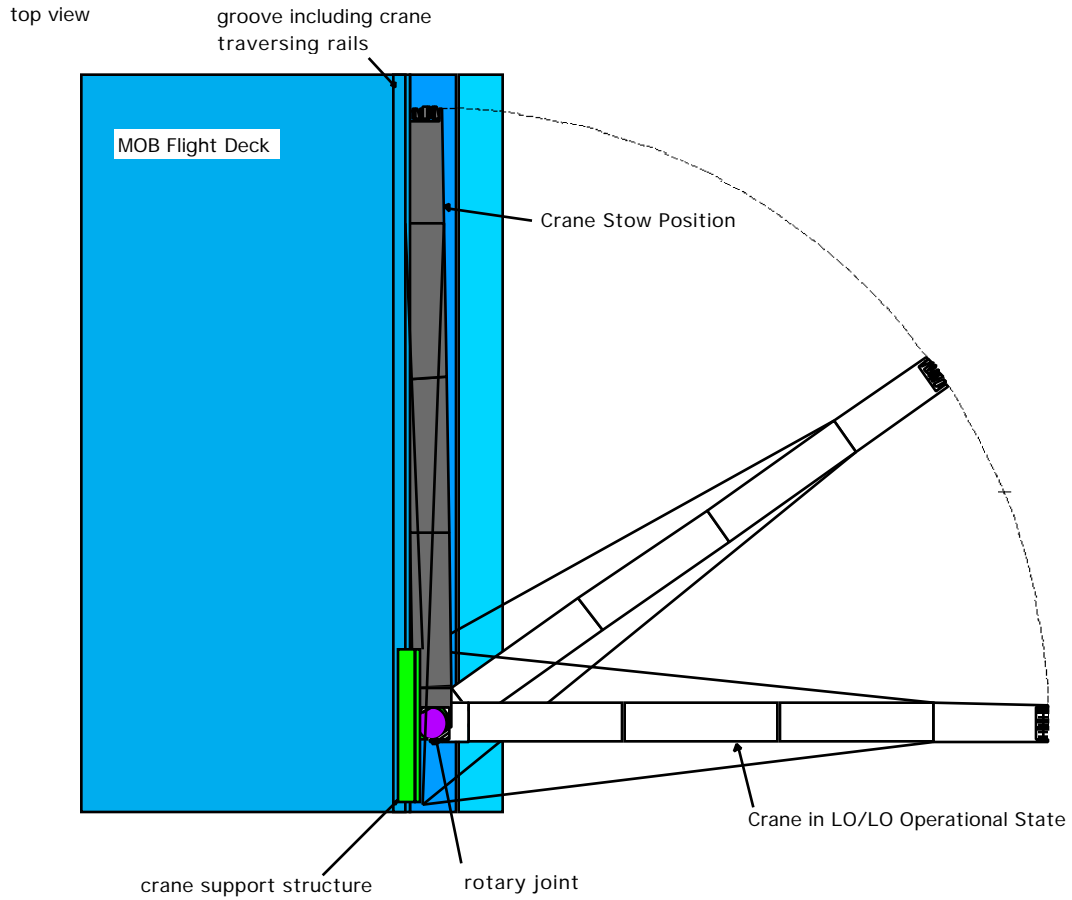

## **RECOMMENDED ACTION ITEMS AND EFFORTS**

---

The following recommendations are suggested to concept developers.

### **Consider the concept of an artificial beach for landing LCACs and for loading lighters.**

As discussed in the requirements section, the containers need to be transferred from the MOB to lighters. The preliminary MOB design of McDermott Shipbuilding Inc. includes the concept of an artificial beach, a sloping shelf, for landing and loading LCACs and lighters, and for stowing causeway sections.

Other concept designers should consider this concept or alternative features to accomplish the same functions. For some concepts, a sheltered area or well deck, similar to those included in amphibious dock, assault, transport, and dock landing ships (LHD, LHA, LPD, and LSD, respectively), might fulfill this function.

### **Design the flight deck to be capable of supporting cranes.**

For MOB designs with overhanging flight decks, cranes may have to be attached to the underside of the flight deck. The majority of the forces are located at or near the edge of the deck where some MOB designs currently show the thinnest structure. Therefore, because high forces from the crane can appear at any point along the deck edge, the crane attachment to the MOB must be supported. A rail to support the cranes will be needed at the edge of the flight deck and a second rail along the side of MOB. Maximum dynamic forces felt by the MOB during typical LO/LO operations is on the order of 14 MN (1,550 tons).

### **Simulate and model the cranes required for cargo handling.**

Scale models of a rail crane, luffing crane, triangular crane, and box crane have been constructed at NIST. These have provided some insight into the crane requirements for the MOB concepts developed by Brown and Root and McDermott. For other concept developers, it would be very useful to simulate and build a scale model of proposed container cranes and their interface to the MOB. The models could be used to verify the concept design, such as the pulley and winch locations, the stability of the cargo as a two or three stage compensation system is attached to this model, actuated boom raise, crane traversal along the MOB, and computer controlled cargo acquisition.



**Develop the advanced computer control system necessary to achieve wave motion compensation.**

Upon construction of a representative rail crane as described in this report, the model will demonstrate static control of the spreader bar and verify stability requirements. Additionally, the crane model must also demonstrate, under computer control, the synchronized winch control that will be required of a full-scale version of the crane to achieve relative motion compensation. Algorithms must be designed and demonstrated to achieve continuous servo control of the trolley and the taglines for full operator assisted/monitored six degree-of-freedom spreader bar and cargo control during high sea state conditions.

**Address specific cargo handling requirements for different MOB missions.**

As different MOB mission requirements and operational scenarios are developed, it will be necessary to look at the proposed cargo handling systems to verify that they can meet the mission requirements.

## REFERENCES

---

1. Mobile Offshore Base Technology Review Conference, Management Support Technology, Inc., October 21-23, 1997.
2. JPD, Mission Need Statement For The Mobile Offshore Base (MOB), ACAT Level I, September 15, 1995.
3. Syntek, Mobile Offshore Base Concept of Operations, (draft), January 1998.
4. CNO Strategic Sealift Division (N-42), Cargo Offload and Discharge System (COLDS), October 1992.
5. T. G. Vaughters, M.F. Mardiros, Joint Logistics Over the Shore Operations in Rough Seas, Naval Engineers Journal, pp. 385-396, May 1997.
6. Donald Bouchoux, Whitney, Bradley & Brown, Inc. BB, The MOB as a Supplement to the CVX, January 29, 1998.
7. Seaworthy Systems, Inc., Preliminary Design Mobile Offshore Base Ship Interface, (draft), April 1, 1997.
8. Cooper, Kelly, "Motion Responses for Selected Cargo Location Points on a T-ACS Auxiliary Crane Ship in an Open Seaway," Carderock Naval Systems Warfare Center, Sept. 1996: Tables 3 and 4: Ochi-Hubble Spectra Corresponding to Natural Roll.
9. Albus, James; Bostelman, Roger; and Jacoff, Adam; MOB RoboCrane Final Report, Mobile Offshore Base Project, Vol. 1, 2, NIST Internal Report (draft), 1997.
10. E.J. Dougherty, D.E. Lee, and P.D. Shively, Automated All-weather Cargo Transfer System (AACTS), Society of Naval Architects and Marine Engineers, STAR Symposium, pp S2-3-1, S2-3-6, April, 1989
11. General Charles Krulak, MPF 2010 and Beyond, December 30, 1998, reprinted in Inside the Navy, January 12, 1998.
12. Bob Webb, Naval Facilities Engineering Command, draft RFP for the Joint Modular Lighter System (JMLS) Mission Need Statement, Civil Engineering Support Office (CESO), <http://199.123.61.61>
13. John Nance, Jr., Vito R. Milano, Robert M. Souders, and Thomas A. Bowditch, Mission Area Analysis (MAA) for Maritime Prepositioning force (MPF) Future Seabasing Concepts Phase 1 Summary Report, Center for Naval Analyses, CRM 97-102.09, 26 Sept. 1997.
14. Jack Nance, Dry Cargo and Vehicle Lift Requirements, MPF MAA Study Notice #23, Center for Naval Analyses, 29 Sept. 1997.