

2.0 AIRPLANE DESCRIPTION

2.1 General Characteristics

2.2 General Dimensions

2.3 Ground Clearances

2.4 Interior Arrangements

2.5 Cabin Cross Sections

2.6 Lower Cargo Compartments

2.7 Door Clearances

2.0 AIRPLANE DESCRIPTION

2.1 General Characteristics

Maximum Design Taxi Weight (MTW). Maximum weight for ground maneuver as limited by aircraft strength and airworthiness requirements. (It includes weight of taxi and run-up fuel.)

Maximum Design Landing Weight (MLW). Maximum weight for landing as limited by aircraft strength and airworthiness requirements.

Maximum Design Takeoff Weight (MTOW). Maximum weight for takeoff as limited by aircraft strength and airworthiness requirements. (This is the maximum weight at start of the takeoff run.)

Operating Empty Weight (OEW). Weight of structure, powerplant, furnishing systems, unusable fuel and other unusable propulsion agents, and other items of equipment that are considered an integral part of a particular airplane configuration. Also included are certain standard items, personnel, equipment, and supplies necessary for full operations, excluding usable fuel and payload.

Maximum Design Zero Fuel Weight (MZFW). Maximum weight allowed before usable fuel and other specified usable agents must be loaded in defined sections of the aircraft as limited by strength and airworthiness requirements.

Maximum Payload. Maximum design zero fuel weight minus operational empty weight.

Maximum Seating Capacity. The maximum number of passengers specifically certificated or anticipated for certification.

Maximum Cargo Volume. The maximum space available for cargo.

Usable Fuel. Fuel available for aircraft propulsion.

CHARACTERISTICS	UNITS	CF6-80C2B1 ENGINES				
MAX DESIGN	POUNDS	803,000	836,000	853,000	873,000	877,000
TAXI WEIGHT	KILOGRAMS	364,235	379,204	386,915	395,987	397,801
MAX DESIGN	POUNDS	800,000	833,000	850,000	870,000	875,000
TAKEOFF WEIGHT	KILOGRAMS	362,874	377,843	385,554	394,626	396,894
MAX DESIGN	POUNDS	574,000	574,000	630,000	630,000	630,000
LANDING WEIGHT (1)	KILOGRAMS	260,362	260,362	285,764	285,764	285,764
MAX DESIGN	POUNDS	535,000	535,000	535,000	542,500	542,500
ZERO FUEL WEIGHT (2)	KILOGRAMS	242,672	242,672	242,672	246,074	246,074
SPEC OPERATING	POUNDS	394,088	394,088	394,088	394,088	394,088
EMPTY WEIGHT (3)	KILOGRAMS	178,756	178,756	178,756	178,756	178,756
MAX STRUCTURAL	POUNDS	140,912	140,912	140,912	148,412	148,412
PAYLOAD	KILOGRAMS	63,917	63,917	63,917	67,319	67,319
TYPICAL SEATING CAPACITY (INCLUDES UPPER DECK)	UPPER DECK	42 BUSINESS CLASS				
	MAIN DECK	24 FIRST, 32 BUSINESS, 302 ECONOMY				
MAX CARGO - LOWER DECK	CUBIC FEET	5,536	5,536	5,536	5,536	5,536
CONTAINERS (LD-1)	CUBIC METERS	157	157	157	157	157
MAX CARGO - LOWER DECK	CUBIC FEET	835	835	835	835	835
BULK CARGO	CUBIC METERS	24	24	24	24	24
USABLE FUEL CAPACITY (4)	U.S. GALLONS	53,765	53,763	53,765	57,065	57,065
	LITERS	203,501	203,493	203,501	215,991	215,991
	POUNDS	360,226	360,226	360,226	382,336	382,336
	KILOGRAMS	163,396	163,396	163,396	173,425	173,425

NOTES:

1. 630,000 LB LANDING WEIGHT IS OPTIONAL
2. 542,500 LB ZERO FUEL WEIGHT IS OPTIONAL
3. SPEC OPERATING EMPTY WEIGHT REFLECTS THREE-CLASS 400-PASSENGER ARRANGEMENT AND STANDARD ITEM ALLOWANCES. ACTUAL OEW WILL VARY WITH AIRPLANE CONFIGURATION. CONSULT USING AIRLINE FOR ACTUAL OEW.
4. OPTIONAL TAIL FUEL OF 3,300 US GAL IS REFLECTED IN THE HIGHER FUEL CAPACITY.

2.1.1 GENERAL CHARACTERISTICS

MODEL 747-400 (GENERAL ELECTRIC ENGINES)

CHARACTERISTICS	UNITS	PW 4056 ENGINES				
MAX DESIGN	POUNDS	803,000	836,000	853,000	873,000	877,000
TAXI WEIGHT	KILOGRAMS	364,235	379,204	386,915	395,987	397,801
MAX DESIGN	POUNDS	800,000	833,000	850,000	870,000	875,000
TAKEOFF WEIGHT	KILOGRAMS	362,874	377,843	385,554	394,626	396,894
MAX DESIGN	POUNDS	574,000	574,000	630,000	630,000	630,000
LANDING WEIGHT (1)	KILOGRAMS	260,362	260,362	285,764	285,764	285,764
MAX DESIGN	POUNDS	535,000	535,000	535,000	542,500	542,500
ZERO FUEL WEIGHT (2)	KILOGRAMS	242,672	242,672	242,672	246,074	246,074
SPEC OPERATING	POUNDS	394,660	394,660	394,660	394,660	394,660
EMPTY WEIGHT (3)	KILOGRAMS	179,015	179,015	179,015	179,015	179,015
MAX STRUCTURAL	POUNDS	140,340	140,340	140,340	147,840	147,840
PAYLOAD	KILOGRAMS	63,657	63,657	63,657	67,059	67,059
TYPICAL SEATING CAPACITY (INCLUDES UPPER DECK)	UPPER DECK	42 BUSINESS CLASS				
	MAIN DECK	24 FIRST, 32 BUSINESS, 302 ECONOMY				
MAX CARGO - LOWER DECK	CUBIC FEET	5,536	5,536	5,536	5,536	5,536
CONTAINERS (LD-1)	CUBIC METERS	157	157	157	157	157
MAX CARGO - LOWER DECK	CUBIC FEET	835	835	835	835	835
BULK CARGO	CUBIC METERS	24	24	24	24	24
USABLE FUEL CAPACITY (4)	U.S. GALLONS	53,985	53,985	53,985	57,285	57,285
	LITERS	204,333	204,333	204,333	216,824	216,824
	POUNDS	361,700	361,700	361,700	383,810	383,810
	KILOGRAMS	164,064	164,064	164,064	174,093	174,093

NOTES

1. 630,000 LB LANDING WEIGHT IS OPTIONAL
2. 542,500 LB ZERO FUEL WEIGHT IS OPTIONAL
3. SPEC OPERATING EMPTY WEIGHT REFLECTS THREE-CLASS 400-PASSENGER ARRANGEMENT AND STANDARD ITEM ALLOWANCES. ACTUAL OEW WILL VARY WITH AIRLINE CONFIGURATION AND OPTIONAL EQUIPMENT. CONSULT USING AIRLINE FOR ACTUAL OEW
4. OPTIONAL TAIL FUEL OF 3,300 US GAL IS REFLECTED IN THE HIGHER FUEL CAPACITY

2.1.2 GENERAL CHARACTERISTICS

MODEL 747-400 (PRATT & WHITNEY ENGINES)

D6-58326-1

10 DECEMBER 2002

CHARACTERISTICS	UNITS	RB211-524G2 ENGINES				
MAX DESIGN	POUNDS	803,000	836,000	853,000	873,000	877,000
TAXI WEIGHT	KILOGRAMS	364,235	379,204	386,915	395,987	397,801
MAX DESIGN	POUNDS	800,000	833,000	850,000	870,000	875,000
TAKEOFF WEIGHT	KILOGRAMS	362,874	377,843	385,554	394,626	396,894
MAX DESIGN	POUNDS	574,000	574,000	630,000	630,000	630,000
LANDING WEIGHT (1)	KILOGRAMS	260,362	260,362	285,764	285,764	285,764
MAX DESIGN	POUNDS	535,000	535,000	535,000	545,000	545,000
ZERO FUEL WEIGHT (2)	KILOGRAMS	242,672	242,672	242,672	247,208	247,208
SPEC OPERATING	POUNDS	396,284	396,284	396,284	396,284	396,284
EMPTY WEIGHT (3)	KILOGRAMS	179,752	179,752	179,752	179,752	179,752
MAX STRUCTURAL	POUNDS	138,716	138,716	138,716	148,716	148,716
PAYLOAD	KILOGRAMS	62,921	62,921	62,921	67,457	67,457
TYPICAL SEATING CAPACITY (INCLUDES UPPER DECK)	UPPER DECK	42 BUSINESS CLASS				
	MAIN DECK	24 FIRST, 32 BUSINESS, 302 ECONOMY				
MAX CARGO - LOWER DECK	CUBIC FEET	5,536	5,536	5,536	5,536	5,536
CONTAINERS (LD-1)	CUBIC METERS	157	157	157	157	157
MAX CARGO - LOWER DECK	CUBIC FEET	835	835	835	835	835
BULK CARGO	CUBIC METERS	24	24	24	24	24
USABLE FUEL CAPACITY (4)	U.S. GALLONS	53,985	53,985	53,985	57,285	57,285
	LITERS	204,333	204,333	204,333	216,824	216,824
	POUNDS	361,700	361,700	361,700	383,810	383,810
	KILOGRAMS	164,064	164,064	164,064	174,093	174,093

NOTES:

1. 630,000 LB LANDING WEIGHT IS OPTIONAL
2. 545,000 LB ZERO FUEL WEIGHT IS OPTIONAL
3. SPEC OPERATING EMPTY WEIGHT REFLECTS THREE-CLASS 400-PASSENGER ARRANGEMENT AND STANDARD ITEM ALLOWANCES. ACTUAL OEW WILL VARY WITH AIRLINE CONFIGURATION AND OPTIONAL EQUIPMENT. CONSULT USING AIRLINE FOR ACTUAL OEW.
4. OPTIONAL TAIL FUEL OF 3,300 US GAL IS REFLECTED IN THE HIGHER FUEL CAPACITY.

2.1.3 GENERAL CHARACTERISTICS

MODEL 747-400 (ROLLS-ROYCE ENGINES)

CHARACTERISTICS	UNITS	CF6-80C2B1 ENGINES				
MAX DESIGN	POUNDS	803,000	836,000	853,000	873,000	877,000
TAXI WEIGHT	KILOGRAMS	364,235	379,204	386,915	395,987	397,801
MAX DESIGN	POUNDS	800,000	833,000	850,000	870,000	875,000
TAKEOFF WEIGHT	KILOGRAMS	362,874	377,843	385,554	394,626	396,894
MAX DESIGN	POUNDS	574,000	574,000	630,000	630,000	630,000
LANDING WEIGHT (1)	KILOGRAMS	260,362	260,362	285,764	285,764	285,764
MAX DESIGN	POUNDS	545,000	545,000	545,000	565,000	565,000
ZERO FUEL WEIGHT (2)	KILOGRAMS	247,208	247,208	247,208	256,280	256,280
SPEC OPERATING	POUNDS	407,107	407,107	407,107	402,900	402,900
EMPTY WEIGHT (3)	KILOGRAMS	184,661	184,661	184,661	182,753	182,753
MAX STRUCTURAL	POUNDS	137,893	137,893	137,893	162,100	162,100
PAYLOAD	KILOGRAMS	62,547	62,547	62,547	73,527	73,527
TYPICAL SEATING CAPACITY (INCLUDES UPPER DECK)	PASSENGER	400: 24 FIRST, 74 BUSINESS, 302 ECONOMY				
	COMBI	345: 28 FIRST, 110 BUSINESS, 207 ECONOMY, 7 PALLETS				
MAX CARGO - MAIN DECK	CUBIC FEET	4,290	4,290	4,290	4,290	4,290
PALLETS (4)	CUBIC METERS	122	122	122	122	122
MAX CARGO - LOWER DECK	CUBIC FEET	5,536	5,536	5,536	5,536	5,536
CONTAINERS (LD-1)	CUBIC METERS	157	157	157	157	157
MAX CARGO - LOWER DECK	CUBIC FEET	710	710	710	710	710
BULK CARGO	CUBIC METERS	20	20	20	20	20
USABLE FUEL CAPACITY (5)	U.S. GALLONS	53,765	53,763	53,765	57,065	57,065
	LITERS	203,501	203,493	203,501	215,991	215,991
	POUNDS	360,226	360,226	360,226	382,336	382,336
	KILOGRAMS	163,396	163,396	163,396	173,425	173,425

NOTES:

1. 630,000 LB LANDING WEIGHT IS OPTIONAL
2. 565,000 LB ZERO FUEL WEIGHT IS OPTIONAL
3. SPEC OPERATING EMPTY WEIGHT REFLECTS THREE-CLASS 400-PASSENGER ARRANGEMENT AND STANDARD ITEM ALLOWANCES. ACTUAL OEW WILL VARY WITH AIRLINE CONFIGURATION AND OPTIONAL EQUIPMENT. CONSULT USING AIRLINE FOR ACTUAL OEW. THE LOWER OEW VALUE REFLECTS PASSENGER/CARGO CONFIGURATION.
4. SEVEN PALLETS AT 613 CUBIC FEET EACH
5. OPTIONAL TAIL FUEL OF 3,300 US GAL IS REFLECTED IN THE HIGHER FUEL CAPACITY

2.1.4 GENERAL CHARACTERISTICS

MODEL 747-400 COMBI (GENERAL ELECTRIC ENGINES)

D6-58326-1

12 DECEMBER 2002

CHARACTERISTICS	UNITS	PW 4056 ENGINES				
MAX DESIGN TAXI WEIGHT	POUNDS	803,000	836,000	853,000	873,000	877,000
	KILOGRAMS	364,235	379,204	386,915	395,987	397,801
MAX DESIGN TAKEOFF WEIGHT	POUNDS	800,000	833,000	850,000	870,000	875,000
	KILOGRAMS	362,874	377,843	385,554	394,626	396,894
MAX DESIGN LANDING WEIGHT (1)	POUNDS	574,000	574,000	630,000	630,000	630,000
	KILOGRAMS	260,362	260,362	285,764	285,764	285,764
MAX DESIGN ZERO FUEL WEIGHT (2)	POUNDS	545,000	545,000	545,000	565,000	565,000
	KILOGRAMS	247,208	247,208	247,208	256,280	256,280
SPEC OPERATING EMPTY WEIGHT (3)	POUNDS	407,479	407,479	407,479	403,400	403,400
	KILOGRAMS	184,830	184,830	184,830	182,979	182,979
MAX STRUCTURAL PAYLOAD	POUNDS	137,521	137,521	137,521	161,600	161,600
	KILOGRAMS	62,379	62,379	62,379	73,301	73,301
TYPICAL SEATING CAPACITY (INCLUDES UPPER DECK)	PASSENGER	400: 24 FIRST, 74 BUSINESS, 302 ECONOMY				
	COMBI	345: 28 FIRST, 110 BUSINESS, 207 ECONOMY, 7 PALLETS				
MAX CARGO - MAIN DECK PALLETS (4)	CUBIC FEET	4,290	4,290	4,290	4,290	4,290
	CUBIC METERS	122	122	122	122	122
MAX CARGO - LOWER DECK CONTAINERS (LD-1)	CUBIC FEET	5,536	5,536	5,536	5,536	5,536
	CUBIC METERS	157	157	157	157	157
MAX CARGO - LOWER DECK BULK CARGO	CUBIC FEET	710	710	710	710	710
	CUBIC METERS	20	20	20	20	20
USABLE FUEL CAPACITY (5)	U.S. GALLONS	53,985	53,985	53,985	57,285	57,285
	LITERS	204,333	204,333	204,333	216,824	216,824
	POUNDS	361,700	361,700	361,700	383,810	383,810
	KILOGRAMS	164,064	164,064	164,064	174,093	174,093

NOTES:

1. 630,000 LB LANDING WEIGHT IS OPTIONAL
2. 565,000 LB ZERO FUEL WEIGHT IS OPTIONAL
3. SPEC OPERATING EMPTY WEIGHT REFLECTS THREE-CLASS 400-PASSENGER ARRANGEMENT AND STANDARD ITEM ALLOWANCES. ACTUAL OEI WILL VARY WITH AIRLINE CONFIGURATION AND OPTIONAL EQUIPMENT. CONSULT USING AIRLINE FOR ACTUAL OEI. THE LOWER OEI VALUE REFLECTS PASSENGER/CARGO CONFIGURATION.
4. SEVEN PALLETS AT 613 CUBIC FEET EACH
5. OPTIONAL TAIL FUEL OF 3,300 US GAL IS REFLECTED IN THE HIGHER FUEL CAPACITY.

2.1.5 GENERAL CHARACTERISTICS

MODEL 747-400 COMBI (PRATT & WHITNEY ENGINES)

D6-58326-1

CHARACTERISTICS	UNITS	RB211-534G2 ENGINES				
MAX DESIGN	POUNDS	803,000	836,000	853,000	873,000	877,000
TAXI WEIGHT	KILOGRAMS	364,235	379,204	386,915	395,987	397,801
MAX DESIGN	POUNDS	800,000	833,000	850,000	870,000	875,000
TAKEOFF WEIGHT	KILOGRAMS	362,874	377,843	385,554	394,626	396,894
MAX DESIGN	POUNDS	574,000	574,000	630,000	630,000	630,000
LANDING WEIGHT (1)	KILOGRAMS	260,362	260,362	285,764	285,764	285,764
MAX DESIGN	POUNDS	545,000	545,000	545,000	565,000	565,000
ZERO FUEL WEIGHT (2)	KILOGRAMS	247,208	247,208	247,208	256,280	256,280
SPEC OPERATING	POUNDS	410,103	410,103	410,103	405,900	405,900
EMPTY WEIGHT (3)	KILOGRAMS	186,020	186,020	186,020	184,113	184,113
MAX STRUCTURAL	POUNDS	134,897	134,897	134,897	159,100	159,100
PAYLOAD	KILOGRAMS	61,188	61,188	61,188	72,167	72,167
TYPICAL SEATING CAPACITY (INCLUDES UPPER DECK)	PASSENGER	400: 24 FIRST, 74 BUSINESS, 302 ECONOMY				
	COMBI	345: 28 FIRST, 110 BUSINESS, 207 ECONOMY, 7 PALLETS				
MAX CARGO - MAIN DECK	CUBIC FEET	4,290	4,290	4,290	4,290	4,290
PALLETS (4)	CUBIC METERS	122	122	122	122	122
MAX CARGO - LOWER DECK	CUBIC FEET	5,536	5,536	5,536	5,536	5,536
CONTAINERS (LD-1)	CUBIC METERS	157	157	157	157	157
MAX CARGO - LOWER DECK	CUBIC FEET	710	710	710	710	710
BULK CARGO	CUBIC METERS	20	20	20	20	20
USABLE FUEL CAPACITY (5)	U.S. GALLONS	53,985	53,985	53,985	57,285	57,285
	LITERS	204,333	204,333	204,333	216,824	216,824
	POUNDS	361,700	361,700	361,700	383,810	383,810
	KILOGRAMS	164,064	164,064	164,064	174,093	174,093

NOTES:

1. 630,000 LB LANDING WEIGHT IS OPTIONAL
2. 565,000 LB ZERO FUEL WEIGHT IS OPTIONAL
3. SPEC OPERATING EMPTY WEIGHT REFLECTS THREE-CLASS 400-PASSENGER ARRANGEMENT AND STANDARD ITEM ALLOWANCES. ACTUAL OEW WILL VARY WITH AIRLINE CONFIGURATION AND OPTIONAL EQUIPMENT. CONSULT USING AIRLINE FOR ACTUAL OEW THE LOWER OEW VALUE REFLECTS PASSENGER/CARGO CONFIGURATION
4. SEVEN PALLETS AT 613 CUBIC FEET EACH
5. OPTIONAL TAIL FUEL OF 3,300 US GAL IS REFLECTED IN THE HIGHER FUEL CAPACITY

2.1.6 GENERAL CHARACTERISTICS

MODEL 747-400 COMBI (ROLLS-ROYCE ENGINES)

D6-58326-1

14 DECEMBER 2002

CHARACTERISTICS	UNITS	CF6-80C2B1 ENGINES				
MAX DESIGN	POUNDS	803,000	836,000	853,000	873,000	877,000
TAXI WEIGHT	KILOGRAMS	364,235	379,204	386,915	395,987	397,801
MAX DESIGN	POUNDS	800,000	833,000	850,000	870,000	875,000
TAKEOFF WEIGHT	KILOGRAMS	362,874	377,843	385,554	394,626	396,894
MAX DESIGN	POUNDS	652,000	652,000	652,000	666,000	666,000
LANDING WEIGHT (1)	KILOGRAMS	295,743	295,743	295,743	302,093	302,093
MAX DESIGN	POUNDS	610,000	610,000	610,000	635,000	635,000
ZERO FUEL WEIGHT (2)	KILOGRAMS	276,692	276,692	276,692	288,031	288,031
SPEC OPERATING	POUNDS	363,954	363,954	363,954	363,954	363,954
EMPTY WEIGHT (3)	KILOGRAMS	165,087	165,087	165,087	165,087	165,087
MAX STRUCTURAL	POUNDS	246,046	246,046	246,046	271,046	271,046
PAYLOAD	KILOGRAMS	111,605	111,605	111,605	122,945	122,945
TYPICAL CARGO - MAIN DECK	CUBIC FEET	18,720	18,720	18,720	18,720	18,720
CONTAINERS (4)	CUBIC METERS	530	530	530	530	530
MAX CARGO - LOWER DECK	CUBIC FEET	5,536	5,536	5,536	5,536	5,536
CONTAINERS (LD-1)	CUBIC METERS	157	157	157	157	157
MAX CARGO - LOWER DECK	CUBIC FEET	520	520	520	520	520
BULK CARGO	CUBIC METERS	15	15	15	15	15
USABLE FUEL CAPACITY (5)	U.S. GALLONS	53,765	53,763	53,765	57,065	57,065
	LITERS	203,501	203,493	203,501	215,991	215,991
	POUNDS	360,226	360,226	360,226	382,336	382,336
	KILOGRAMS	163,396	163,396	163,396	173,425	173,425

NOTES:

1. 666,000 LB LANDING WEIGHT IS OPTIONAL
2. 635,000 LB ZERO FUEL WEIGHT IS OPTIONAL
3. SPEC OPERATING EMPTY WEIGHT REFLECTS STANDARD ITEM ALLOWANCES. ACTUAL OEW WILL VARY WITH AIRPLANE CONFIGURATION. CONSULT WITH USING AIRLINE FOR ACTUAL OEW
4. TWENTY-NINE 10-FT CONTAINERS. ACTUAL VOLUME WILL DEPEND ON AIRPLANE CONFIGURATION
5. OPTIONAL TAIL FUEL OF 3,300 US GAL IS REFLECTED IN THE HIGHER FUEL CAPACITY.

2.1.7 GENERAL CHARACTERISTICS

MODEL 747-400 FREIGHTER (GENERAL ELECTRIC ENGINES)

CHARACTERISTICS	UNITS	PW 4056 ENGINES				
MAX DESIGN TAXI WEIGHT	POUNDS	803,000	836,000	853,000	873,000	877,000
	KILOGRAMS	364,235	379,204	386,915	395,987	397,801
MAX DESIGN TAKEOFF WEIGHT	POUNDS	800,000	833,000	850,000	870,000	875,000
	KILOGRAMS	362,874	377,843	385,554	394,626	396,894
MAX DESIGN LANDING WEIGHT (1)	POUNDS	652,000	652,000	652,000	666,000	666,000
	KILOGRAMS	295,743	295,743	295,743	302,093	302,093
MAX DESIGN ZERO FUEL WEIGHT (2)	POUNDS	610,000	610,000	610,000	635,000	635,000
	KILOGRAMS	276,692	276,692	276,692	288,031	288,031
SPEC OPERATING EMPTY WEIGHT (3)	POUNDS	364,526	364,526	364,526	364,526	364,526
	KILOGRAMS	165,346	165,346	165,346	165,346	165,346
MAX STRUCTURAL PAYLOAD	POUNDS	245,474	245,474	245,474	270,474	270,474
	KILOGRAMS	111,345	111,345	111,345	122,685	122,685
TYPICAL CARGO - MAIN DECK CONTAINERS (4)	CUBIC FEET	18,720	18,720	18,720	18,720	18,720
	CUBIC METERS	530	530	530	530	530
MAX CARGO - LOWER DECK CONTAINERS (LD-1)	CUBIC FEET	5,536	5,536	5,536	5,536	5,536
	CUBIC METERS	157	157	157	157	157
MAX CARGO - LOWER DECK BULK CARGO	CUBIC FEET	520	520	520	520	520
	CUBIC METERS	15	15	15	15	15
USABLE FUEL CAPACITY (5)	U.S. GALLONS	53,985	53,985	53,985	57,285	57,285
	LITERS	204,333	204,333	204,333	216,824	216,824
	POUNDS	361,700	361,700	361,700	383,810	383,810
	KILOGRAMS	164,064	164,064	164,064	174,093	174,093

NOTES:

1. 666,000 LB LANDING WEIGHT IS OPTIONAL
2. 635,000 LB ZERO FUEL WEIGHT IS OPTIONAL
3. SPEC OPERATING EMPTY WEIGHT REFLECTS STANDARD ITEM ALLOWANCES. ACTUAL OEW WILL VARY WITH AIRPLANE CONFIGURATION. CONSULT WITH USING AIRLINE FOR ACTUAL OEW.
4. TWENTY-NINE 10-FT CONTAINERS. ACTUAL VOLUME WILL DEPEND ON AIRPLANE CONFIGURATION.
5. OPTIONAL TAIL FUEL OF 3,300 US GAL IS REFLECTED IN THE HIGHER FUEL CAPACITY.

2.1.8 GENERAL CHARACTERISTICS

MODEL 747-400 FREIGHTER (PRATT & WHITNEY ENGINES)

D6-58326-1

CHARACTERISTICS	UNITS	RB211-524G2 ENGINES				
MAX DESIGN	POUNDS	803,000	836,000	853,000	873,000	877,000
TAXI WEIGHT	KILOGRAMS	364,235	379,204	386,915	395,987	397,801
MAX DESIGN	POUNDS	800,000	833,000	850,000	870,000	875,000
TAKEOFF WEIGHT	KILOGRAMS	362,874	377,843	385,554	394,626	396,894
MAX DESIGN	POUNDS	652,000	652,000	652,000	666,000	666,000
LANDING WEIGHT (1)	KILOGRAMS	295,743	295,743	295,743	302,093	302,093
MAX DESIGN	POUNDS	610,000	610,000	610,000	635,000	635,000
ZERO FUEL WEIGHT (2)	KILOGRAMS	276,692	276,692	276,692	288,031	288,031
SPEC OPERATING	POUNDS	366,082	366,082	366,082	366,082	366,082
EMPTY WEIGHT (3)	KILOGRAMS	166,052	166,052	166,052	166,052	166,052
MAX STRUCTURAL	POUNDS	243,850	243,850	243,850	268,850	268,850
PAYLOAD	KILOGRAMS	110,609	110,609	110,609	121,948	121,948
TYPICAL CARGO - MAIN DECK	CUBIC FEET	18,720	18,720	18,720	18,720	18,720
CONTAINERS (4)	CUBIC METERS	530	530	530	530	530
MAX CARGO - LOWER DECK	CUBIC FEET	5,536	5,536	5,536	5,536	5,536
CONTAINERS (LD-1)	CUBIC METERS	157	157	157	157	157
MAX CARGO - LOWER DECK	CUBIC FEET	520	520	520	520	520
BULK CARGO	CUBIC METERS	15	15	15	15	15
USABLE FUEL CAPACITY (5)	U.S. GALLONS	53,985	53,985	53,985	57,285	57,285
	LITERS	204,333	204,333	204,333	216,824	216,824
	POUNDS	361,700	361,700	361,700	383,810	383,810
	KILOGRAMS	164,064	164,064	164,064	174,093	174,093

NOTES:

1. 666,000 LB LANDING WEIGHT IS OPTIONAL
2. 635,000 LB ZERO FUEL WEIGHT IS OPTIONAL
3. SPEC OPERATING EMPTY WEIGHT REFLECTS STANDARD ITEM ALLOWANCES. ACTUAL OEW WILL VARY WITH AIRPLANE CONFIGURATION. CONSULT WITH USING AIRLINE FOR ACTUAL OEW.
4. TWENTY-NINE 10-FT CONTAINERS. ACTUAL VOLUME WILL DEPEND ON AIRPLANE CONFIGURATION.
5. OPTIONAL TAIL FUEL OF 3,300 US GAL IS REFLECTED IN THE HIGHER FUEL CAPACITY.

2.1.9 GENERAL CHARACTERISTICS

MODEL 747-400 FREIGHTER (ROLLS ROYCE ENGINES)

D6-58326-1

DECEMBER 2002 17

CHARACTERISTICS	UNITS	GE ENGINES CF6-80C2B5-F	PW ENGINES PW4062	RR ENGINES RB211-524H8-T
MAX DESIGN TAXI WEIGHT	POUNDS	913,000	913,000	913,000
	KILOGRAMS	414,130	414,130	414,130
MAX DESIGN TAKEOFF WEIGHT	POUNDS	910,000	910,000	910,000
	KILOGRAMS	412,770	412,770	412,770
MAX DESIGN LANDING WEIGHT	POUNDS	652,000	652,000	652,000
	KILOGRAMS	295,743	295,743	295,743
MAX DESIGN ZERO FUEL WEIGHT	POUNDS	555,000	555,000	555,000
	KILOGRAMS	251,744	251,744	251,744
SPEC OPERATING EMPTY WEIGHT (1)	POUNDS	406,900	406,900	406,900
	KILOGRAMS	184,567	184,567	184,567
MAX STRUCTURAL PAYLOAD	POUNDS	148,100	148,100	148,100
	KILOGRAMS	67,177	67,177	67,177
TYPICAL SEATING CAPACITY (INCLUDES UPPER DECK)	TWO-CLASS	500: 42 FIRST CLASS, 458 ECONOMY CLASS		
	THREE-CLASS	416: 23 FIRST CLASS, 78 BUSINESS CLASS, 315 ECONOMY CLASS		
MAX CARGO - LOWER DECK LD-2 CONTAINERS (2)	CUBIC FEET	4,550	4,550	4,550
	CUBIC METERS	129	129	129
MAX CARGO - LOWER DECK BULK CARGO	CUBIC FEET	789	789	789
	CUBIC METERS	22	22	22
USABLE FUEL CAPACITY (3)	U.S. GALLONS	63,240	63,460	63,460
	LITERS	239,363	240,196	240,196
	POUNDS	423,708	425,182	425,182
	KILOGRAMS	192,191	192,860	192,860

NOTES:

1. SPEC OPERATING EMPTY WEIGHT REFLECTS THREE-CLASS 416-PASSENGER ARRANGEMENT AND STANDARD ITEM ALLOWANCES. ACTUAL OEW WILL VARY WITH AIRPLANE CONFIGURATION. CONSULT USING AIRLINE FOR ACTUAL OEW.
2. REFLECTS TWO BODY FUEL TANKS IN THE FORWARD CARGO COMPARTMENT.
3. INCLUDES TWO BODY FUEL TANKS OF 3,060 U.S. GALLONS EACH.

2.1.10 GENERAL CHARACTERISTICS

MODEL 747-400ER

D6-58326-1

18 DECEMBER 2002

CHARACTERISTICS	UNITS	GE ENGINES CF6-80C2B5-F	PW ENGINES PW4062	RR ENGINES RB211-524H8-T
MAX DESIGN TAXI WEIGHT	POUNDS	913,000	913,000	913,000
	KILOGRAMS	414,130	414,130	414,130
MAX DESIGN TAKEOFF WEIGHT	POUNDS	910,000	910,000	910,000
	KILOGRAMS	412,770	412,770	412,770
MAX DESIGN LANDING WEIGHT	POUNDS	666,000	666,000	666,000
	KILOGRAMS	302,093	302,093	302,093
MAX DESIGN ZERO FUEL WEIGHT	POUNDS	611,000	611,000	611,000
	KILOGRAMS	277,145	277,145	277,145
SPEC OPERATING EMPTY WEIGHT (1)	POUNDS	362,400	362,400	362,400
	KILOGRAMS	164,382	164,382	164,382
MAX STRUCTURAL PAYLOAD	POUNDS	248,600	248,600	248,600
	KILOGRAMS	112,763	112,763	112,763
TYPICAL CARGO – MAIN DECK CONTAINERS (2)	CUBIC FEET	18,720	18,720	18,720
	CUBIC METERS	530	530	530
MAX CARGO - LOWER DECK CONTAINERS (LD-2)	CUBIC FEET	5,600	5,600	5,600
	CUBIC METERS	159	159	159
MAX CARGO - LOWER DECK BULK CARGO	CUBIC FEET	520	520	520
	CUBIC METERS	15	15	15
USABLE FUEL CAPACITY	U.S. GALLONS	53,765	53,985	53,985
	LITERS	203,501	204,333	204,333
	POUNDS	360,226	361,700	361,700
	KILOGRAMS	163,396	164,064	164,064

NOTES:

1. SPEC OPERATING EMPTY WEIGHT REFLECTS STANDARD ITEM ALLOWANCES.
ACTUAL OEW WILL VARY WITH AIRLINE CONFIGURATION AND OPTIONAL EQUIPMENT.
CONSULT USING AIRLINE FOR ACTUAL OEW.
2. TWENTY-NINE 10-FOOT CONTAINERS. ACTUAL VOLUME WILL DEPEND ON AIRPLANE CONFIGURATION.

2.1.11 GENERAL CHARACTERISTICS
MODEL 747-400ER FREIGHTER

CHARACTERISTICS	UNITS	CF6-80C2B1 ENGINES	
MAX DESIGN TAXI WEIGHT	POUNDS	603,000	613,500
	KILOGRAMS	273,517	278,279
MAX DESIGN TAKEOFF WEIGHT	POUNDS	600,000	610,000
	KILOGRAMS	272,156	276,692
MAX DESIGN LANDING WEIGHT	POUNDS	574,000	574,000
	KILOGRAMS	260,362	260,362
MAX DESIGN ZERO FUEL WEIGHT	POUNDS	535,000	535,000
	KILOGRAMS	242,672	242,672
SPEC OPERATING EMPTY WEIGHT (1)	POUNDS	400,630	400,630
	KILOGRAMS	181,723	181,723
MAX STRUCTURAL PAYLOAD	POUNDS	134,370	134,370
	KILOGRAMS	60,949	60,949
TYPICAL SEATING CAPACITY (INCLUDES UPPER DECK)	UPPER DECK	89 ECONOMY	
	MAIN DECK	539 ECONOMY	
MAX CARGO - LOWER DECK CONTAINERS (LD-1)	CUBIC FEET	5,600	5,600
	CUBIC METERS	159	159
MAX CARGO - LOWER DECK BULK CARGO	CUBIC FEET	835	835
	CUBIC METERS	24	24
USABLE FUEL CAPACITY	U.S. GALLONS	53,765	53,763
	LITERS	203,501	203,493
	POUNDS	360,226	360,226
	KILOGRAMS	163,396	163,396

NOTES:

1. SPEC OPERATING EMPTY WEIGHT REFLECTS ALL-ECONOMY 624-PASSENGER ARRANGEMENT AND STANDARD ITEM ALLOWANCES. ACTUAL OEW WILL VARY WITH AIRLINE CONFIGURATION AND OPTIONAL EQUIPMENT. CONSULT USING AIRLINE FOR ACTUAL OEW.

2.1.12 GENERAL CHARACTERISTICS

MODEL 747-400 DOMESTIC (GENERAL ELECTRIC ENGINES)

D6-58326-1

20 DECEMBER 2002

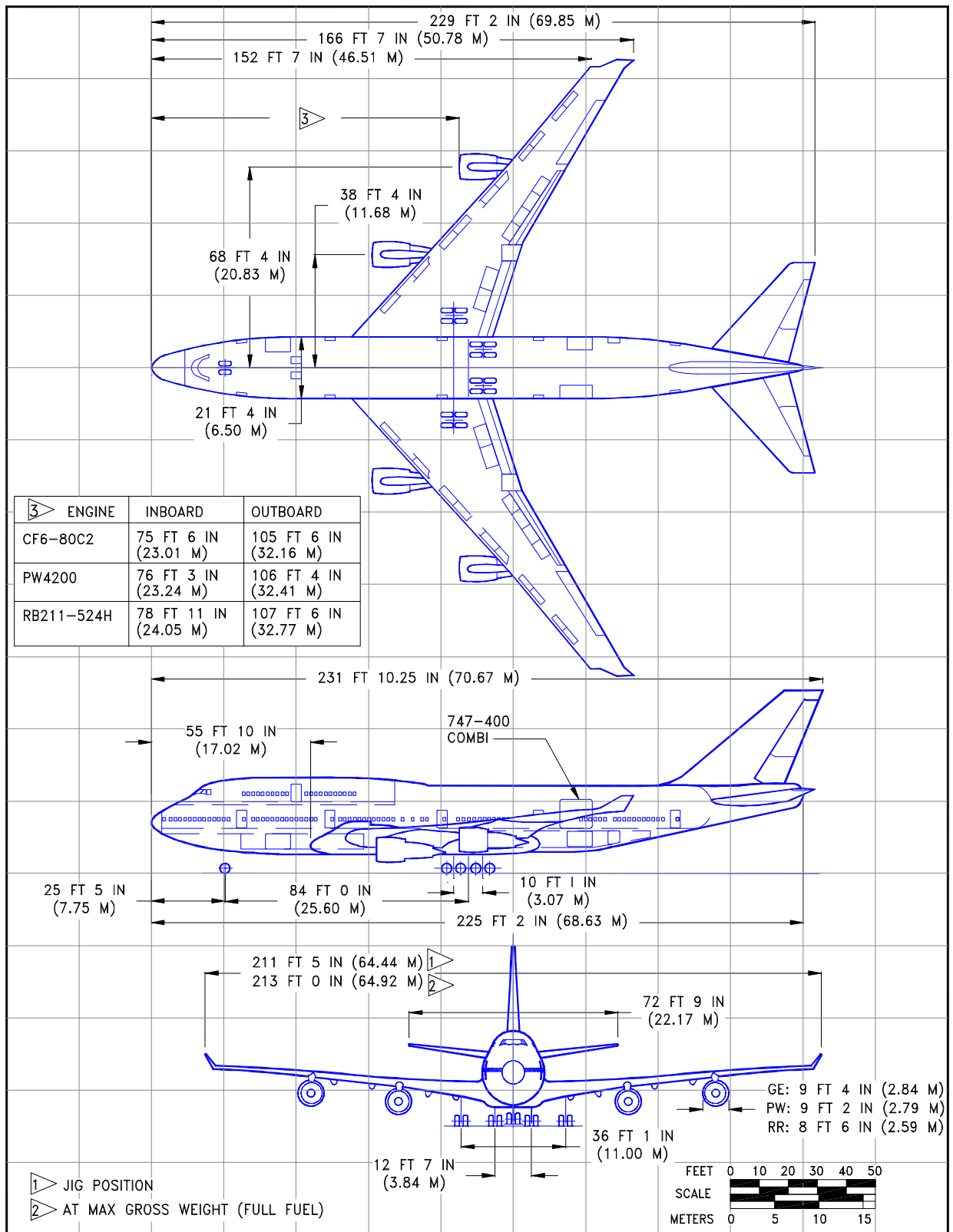

2.2.1 GENERAL DIMENSIONS

MODEL 747-400, -400 COMBI, -400ER

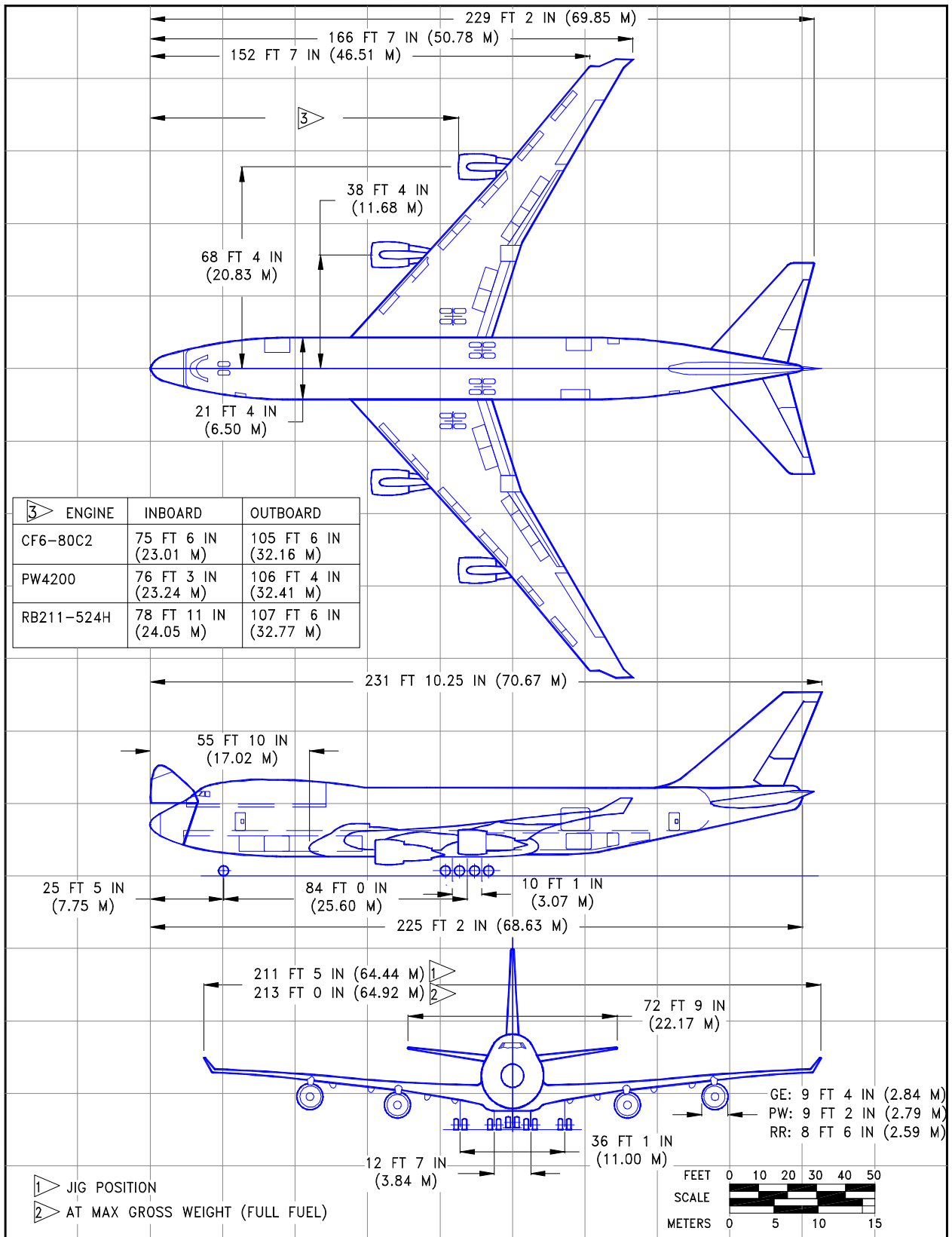

2.2.2 GENERAL DIMENSIONS

MODEL 747-400 FREIGHTER, -400ER FREIGHTER

D6-58326-1

22 DECEMBER 2002

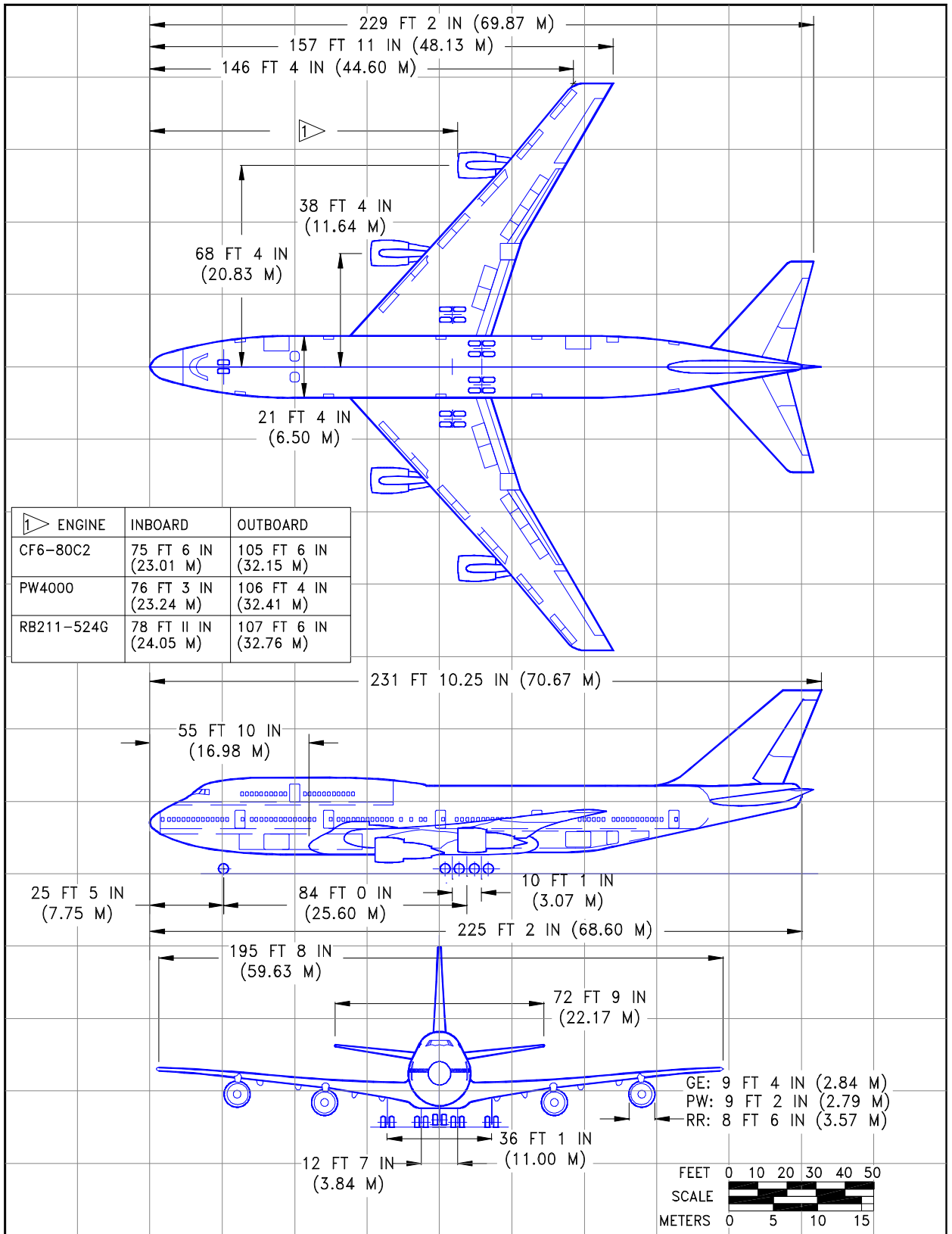

2.2.3 GENERAL DIMENSIONS
 MODEL 747-400 DOMESTIC

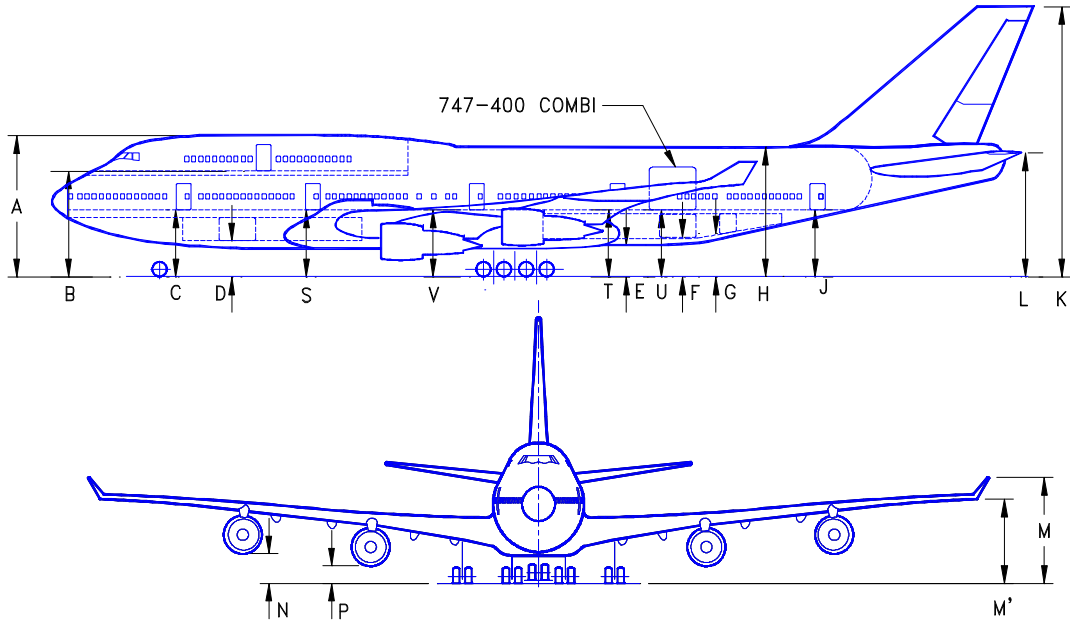

	MINIMUM		MAXIMUM	
	FT - IN	M	FT - IN	M
A	32 - 1	9.80	33 - 6	10.23
B	24 - 8	7.53	25 - 11	7.91
C	15 - 6	4.74	16 - 11	5.18
D	8 - 10	2.71	10 - 2	3.11
E	6 - 10	2.09	7 - 11	2.42
F	9 - 3	2.82	10 - 5	3.18
G	9 - 10	3.00	11 - 2	3.41
H	29 - 7	9.02	31 - 4	9.56
J	15 - 9	4.82	17 - 5	5.33
K	61 - 7	18.80	64 - 0	19.51
L	27 - 6	8.39	29 - 9	9.09
M	22 - 0	6.71	24 - 0	7.32
M'	16 - 9	5.11	18 - 9	5.71
N	4 - 4	1.32	5 - 10	1.80
P	2 - 3	0.71	3 - 0	0.93
S	15 - 9	4.80	16 - 10	5.15
T	16 - 0	4.88	17 - 0	5.19
U	16 - 0	4.88	17 - 3	5.28
V	15 - 11	4.87	16 - 9	5.11

NOTES: VERTICAL CLEARANCES SHOWN OCCUR DURING MAXIMUM VARIATIONS OF AIRPLANE ATTITUDE. COMBINATIONS OF AIRPLANE LOADING AND UNLOADING ACTIVITIES THAT PRODUCE THE GREATEST POSSIBLE VARIATIONS IN ATTITUDE WERE USED TO ESTABLISH THE VARIATIONS SHOWN.

DURING ROUTINE SERVICING, THE AIRPLANE REMAINS RELATIVELY STABLE, PITCH AND ELEVATION CHANGES OCCURRING SLOWLY.

2.3.1 GROUND CLEARANCES

MODEL 747-400, -400 COMBI

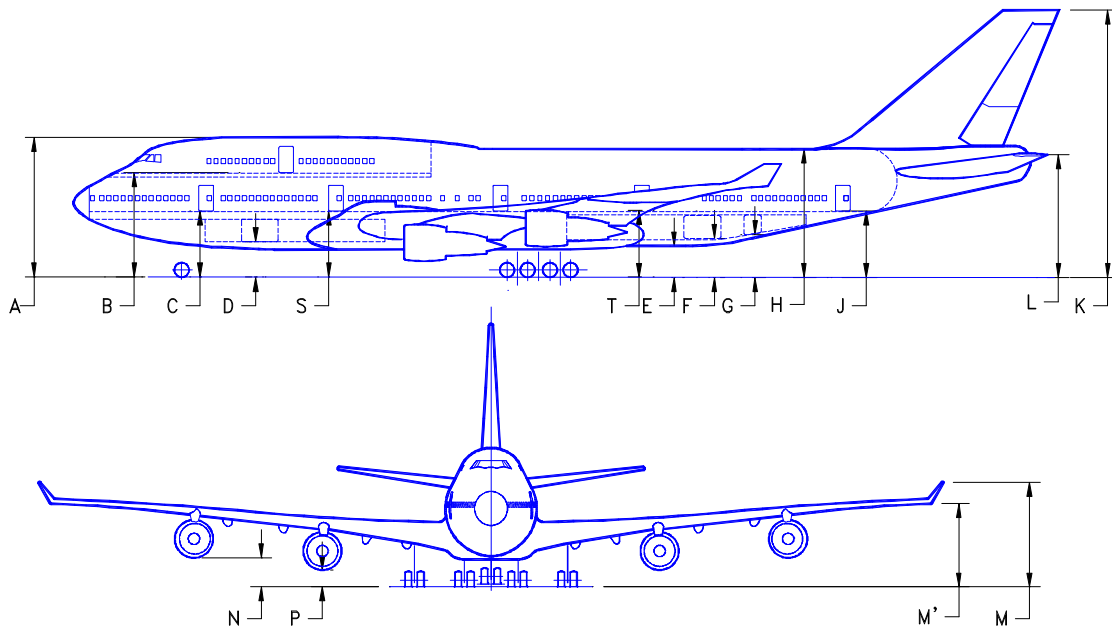

	MINIMUM		MAXIMUM	
	FT - IN	M	FT - IN	M
A	32 - 3	9.82	33 - 7	10.25
B	24 - 9	7.55	26 - 1	7.94
C	15 - 7	4.75	17 - 1	5.20
D	8 - 11	2.73	10 - 3	3.13
E	7 - 1	2.16	8 - 1	2.47
F	9 - 6	2.9	10 - 7	3.23
G	10 - 2	3.11	11 - 5	3.47
H	27 - 9	8.46	31 - 7	9.63
J	16 - 4	4.99	17 - 8	5.40
K	62 - 6	19.06	64 - 3	19.59
L	28 - 4	8.64	30 - 1	9.17
M	22 - 0	6.71	24 - 0	7.32
M'	16 - 9	5.11	18 - 9	5.71
N (PW)	4 - 7	1.40	5 - 10	1.78
N (GE)	4 - 7	1.40	5 - 11	1.80
N (RR)	4 - 4	1.32	5 - 7	1.71
P (PW)	2 - 4	0.71	3 - 0	0.91
P (GE)	2 - 5	0.72	3 - 0	0.91
P (RR)	2 - 4	0.71	3 - 0	0.91
S	15 - 10	4.82	16 - 11	5.16
T	16 - 3	4.95	17 - 2	5.25

- NOTES: 1. VERTICAL CLEARANCES SHOWN OCCUR DURING MAXIMUM VARIATIONS OF AIRPLANE ATTITUDE. COMBINATIONS OF AIRPLANE LOADING AND UNLOADING ACTIVITIES THAT PRODUCE THE GREATEST POSSIBLE VARIATIONS IN ATTITUDE WERE USED TO ESTABLISH THE VARIATIONS SHOWN.
2. DURING ROUTINE SERVICING, THE AIRPLANE REMAINS RELATIVELY STABLE, PITCH AND ELEVATION CHANGES OCCURRING SLOWLY.

2.3.2 GROUND CLEARANCES
MODEL 747-400ER

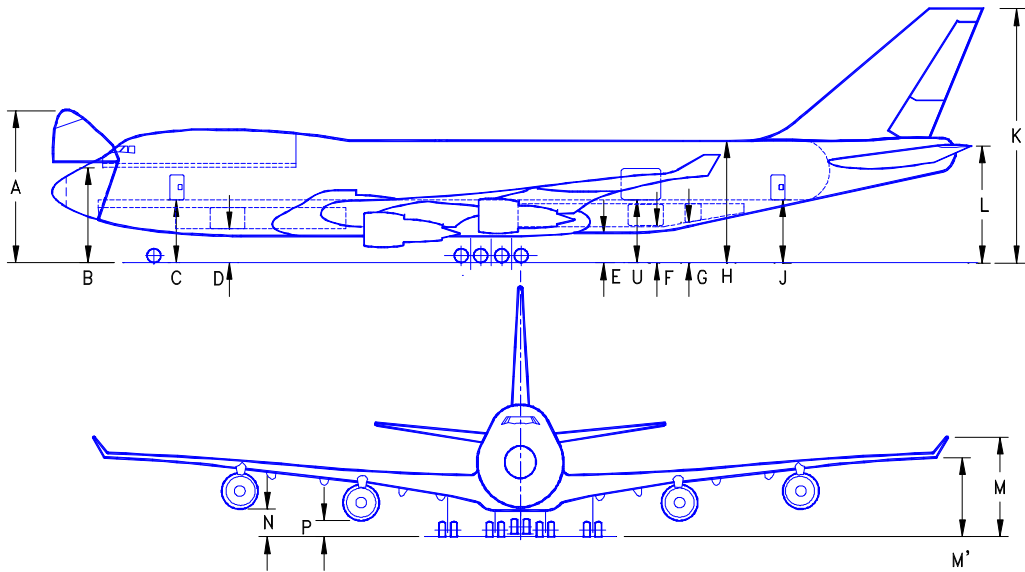

	MINIMUM		MAXIMUM	
	FT - IN	M	FT - IN	M
A	38 - 1	11.63	40 - 1	12.24
B	15 - 6	4.72	17 - 0	5.18
C	24 - 9	7.57	25 - 2	7.67
D	8 - 10	2.71	10 - 3	3.14
E	6 - 10	2.09	7 - 11	2.42
F	9 - 1	2.79	10 - 6	3.21
G	9 - 9	2.98	11 - 3	3.44
H	29 - 6	9.00	31 - 4	9.57
J	15 - 8	4.80	17 - 7	5.37
K	61 - 7	18.78	64 - 1	19.54
L	27 - 5	8.37	29 - 11	9.13
M	22 - 0	6.71	24 - 0	7.32
M'	16 - 9	5.11	18 - 9	5.71
N	4 - 4	1.32	5 - 10	1.80
P	2 - 3	0.71	3 - 0	0.93
S	15 - 9	4.80	16 - 10	5.15
T	16 - 0	4.88	17 - 0	5.19
U	16 - 0	4.88	17 - 3	5.28

NOTES: VERTICAL CLEARANCES SHOWN OCCUR DURING MAXIMUM VARIATIONS OF AIRPLANE ATTITUDE. COMBINATIONS OF AIRPLANE LOADING/UNLOADING ACTIVITIES THAT PRODUCE THE GREATEST POSSIBLE VARIATIONS OF ATTITUDE WERE USED TO ESTABLISH THE VARIATIONS SHOWN. DURING ROUTINE SERVICING, THE AIRPLANE REMAINS RELATIVELY STABLE; PITCH AND ELEVATION CHANGES OCCUR SLOWLY.

AT MAJOR TERMINALS, A GSE TETHERING DEVICE MAY BE USED TO MAINTAIN STABILITY BETWEEN THE MAIN DECK DOOR SILL AND THE LOADING DOCK. CARGO BRIDGE ATTACHMENT FITTINGS LOCATED ON THE NOSE DOOR SILL AT THE FORWARD EDGE OF THE MAIN CARGO DOOR DECK MAY BE USED FOR NOSE DOOR SILL STABILIZATION.

2.3.3 GROUND CLEARANCES
MODEL 747-400 FREIGHTER

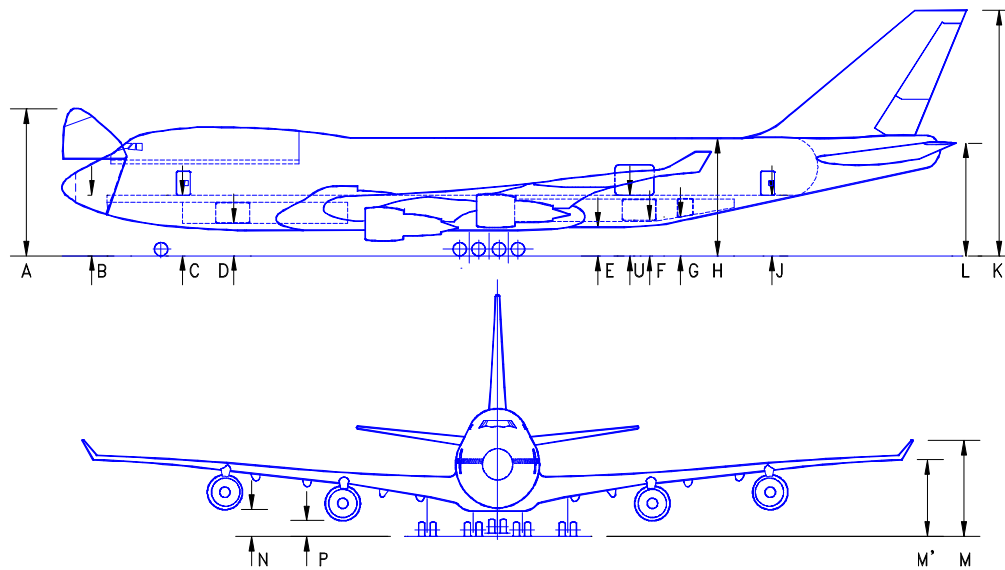

	MINIMUM		MAXIMUM	
	FT - IN	M	FT-IN	M
A	38 - 2	11.79	40 - 2	12.24
B	15 - 6	4.72	17 - 2	5.23
C	15 - 7	4.74	17 - 8	5.37
D	9 - 0	2.75	10 - 9	3.28
E	7 - 1	2.16	8 - 1	2.47
F	9 - 6	2.89	10 - 7	3.23
G	10 - 2	3.10	11 - 4	3.46
H	27 - 9	8.46	31 - 7	9.63
J	16 - 3	4.97	17 - 8	5.38
K	61 - 11	18.87	64 - 1	19.54
L	27 - 9	8.47	29 - 11	9.12
M	22 - 0	6.71	24 - 0	7.32
M'	16 - 9	5.11	18 - 9	5.71
N (PW)	4 - 7	1.40	5 - 10	1.78
N (GE)	4 - 7	1.40	5 - 11	1.80
N (RR)	4 - 4	1.32	5 - 7	1.71
P (PW)	2 - 4	0.71	3 - 0	0.91
P (GE)	2 - 5	0.72	3 - 0	0.91
P (RR)	2 - 4	0.71	3 - 0	0.91
U	16 - 3	4.97	17 - 5	5.31

NOTES: (1) VERTICAL CLEARANCES SHOWN OCCUR DURING MAXIMUM VARIATIONS OF AIRPLANE ATTITUDE. COMBINATIONS OF AIRPLANE LOADING/UNLOADING ACTIVITIES THAT PRODUCE THE GREATEST POSSIBLE VARIATIONS OF ATTITUDE WERE USED TO ESTABLISH THE VARIATIONS SHOWN. DURING ROUTINE SERVICING, THE AIRPLANE REMAINS RELATIVELY STABLE; PITCH AND ELEVATION CHANGES OCCUR SLOWLY.

(2) AT MAJOR TERMINALS, A GSE TETHERING DEVICE JULY BE USED TO MAINTAIN STABILITY BETWEEN THE MAIN DECK DOOR SILL AND THE LOADING DOCK. CARGO BRIDGE ATTACHMENT FITTINGS LOCATED ON THE NOSE DOOR SILL AT THE FORWARD EDGE OF THE MAIN CARGO DOOR DECK JULY BE USED FOR NOSE DOOR SILL STABILIZATION.

2.3.4 GROUND CLEARANCES
MODEL 747-400ER FREIGHTER

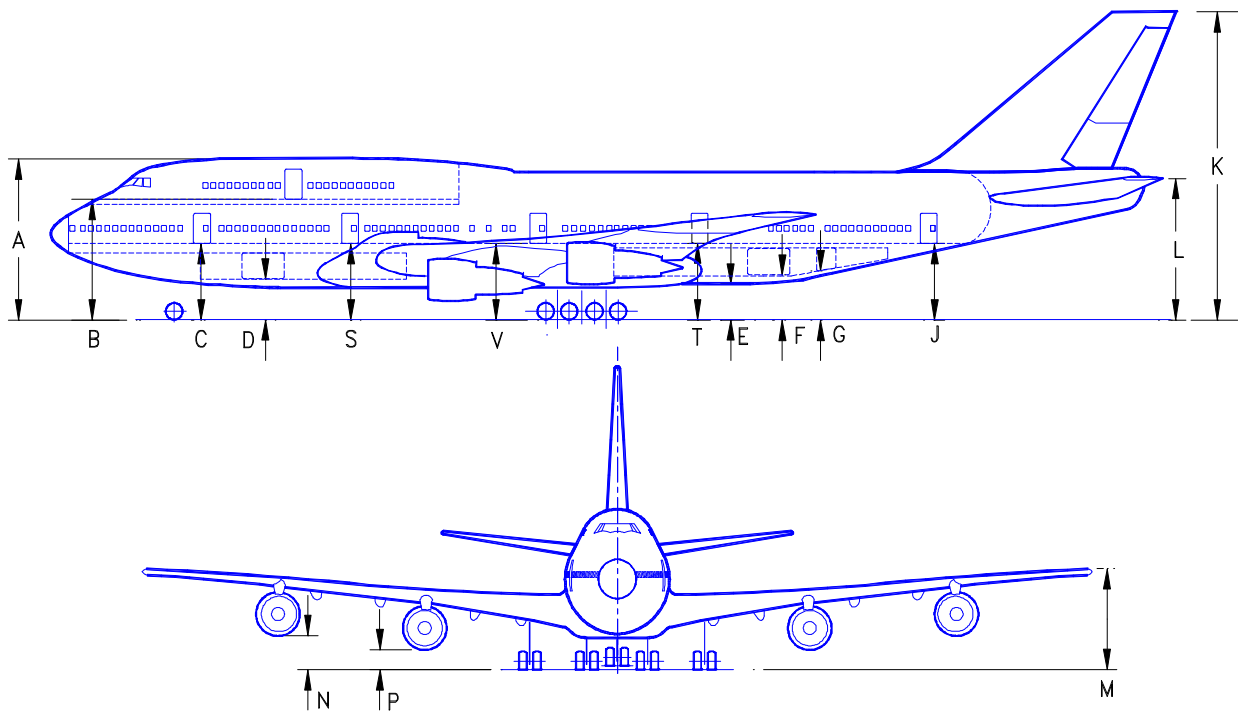

	MINIMUM		MAXIMUM	
	FT - IN	M	FT - IN	M
A	31 - 10	9.70	34 - 1	10.39
B	24 - 10	7.57	27 - 5	8.36
C	15 - 3	4.65	17 - 7	5.36
D	8 - 8	2.64	10 - 8	3.25
E	6 - 3	1.91	6 - 9	2.06
F	8 - 10	2.69	10 - 4	3.15
G	9 - 6	2.90	11 - 4	3.45
H	28 - 6	8.69	31 - 0	9.45
J	15 - 0	4.57	17 - 6	5.33
K	60 - 2	18.34	64 - 3	19.58
L	27 - 0	8.23	30 - 8	9.35
M	17 - 7	5.36	19 - 2	5.84
N	6 - 0	1.83	7 - 0	2.13
P	3 - 9	1.14	4 - 6	1.37
S	15 - 8	4.78	17 - 2	5.23
T	15 - 8	4.78	16 - 7	5.05

NOTES: VERTICAL CLEARANCES SHOWN OCCUR DURING MAXIMUM VARIATIONS OF AIRPLANE ATTITUDE. COMBINATIONS OF AIRPLANE LOADING AND UNLOADING ACTIVITIES THAT PRODUCE THE GREATEST POSSIBLE VARIATIONS IN ATTITUDE WERE USED TO ESTABLISH THE VARIATIONS SHOWN.

DURING ROUTINE SERVICING, THE AIRPLANE REMAINS RELATIVELY STABLE, PITCH AND ELEVATION CHANGES OCCURRING SLOWLY.

2.3.5 GROUND CLEARANCES
MODEL 747-400 DOMESTIC

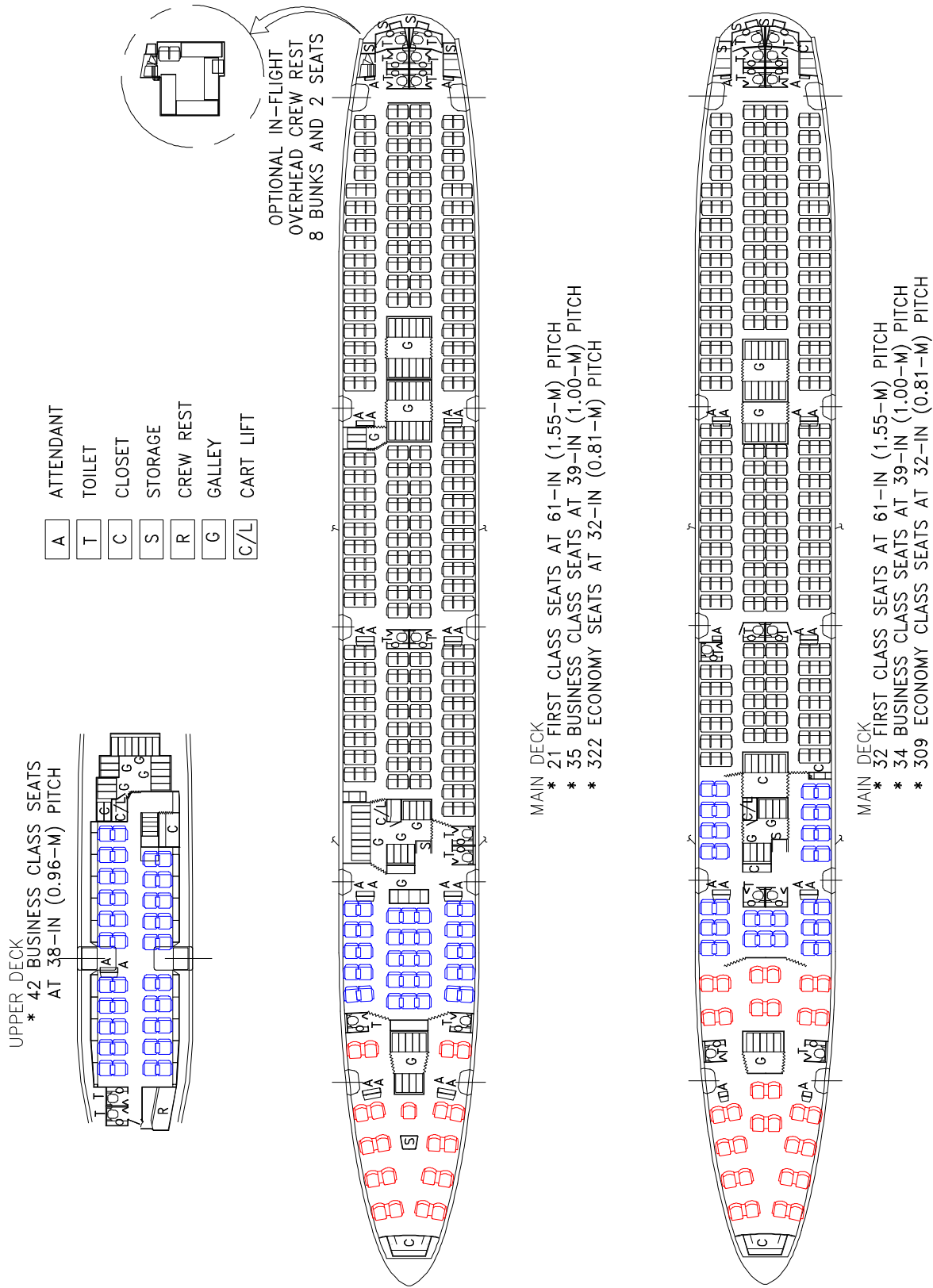

2.4.1 INTERIOR ARRANGEMENTS - TRI-CLASS CONFIGURATION
 MODEL 747-400

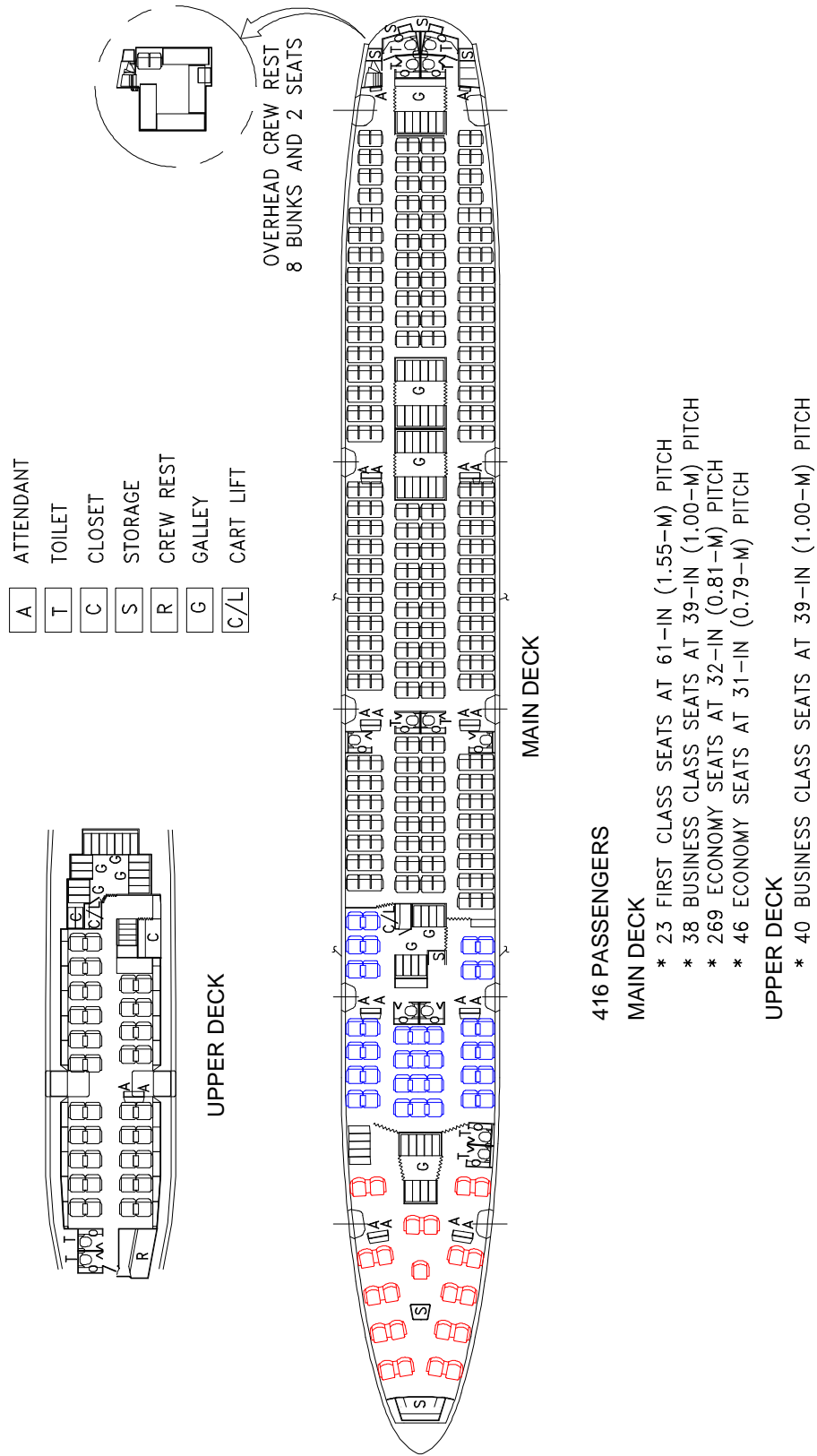

2.4.2 INTERIOR ARRANGEMENTS - TRI-CLASS CONFIGURATION
MODEL 747-400ER

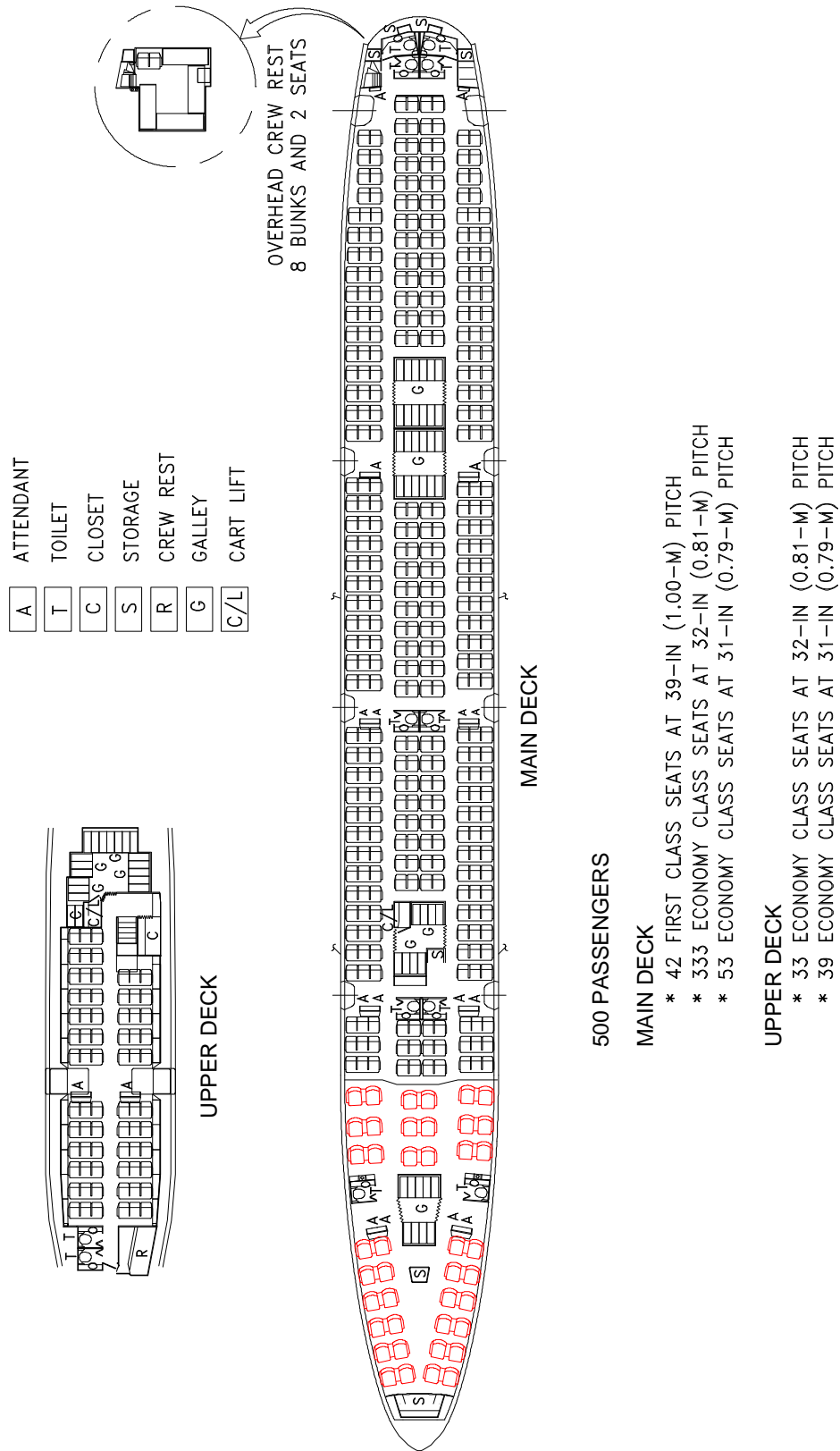

2.4.3 INTERIOR ARRANGEMENTS – DUAL CLASS CONFIGURATION
MODEL 747-400ER

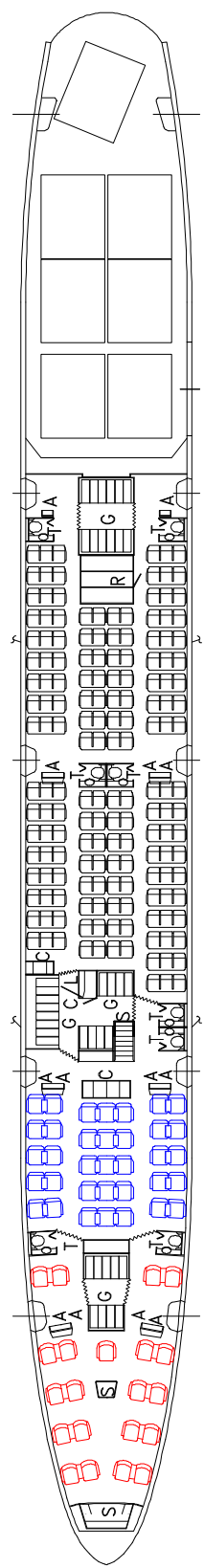
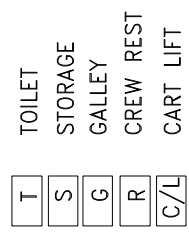
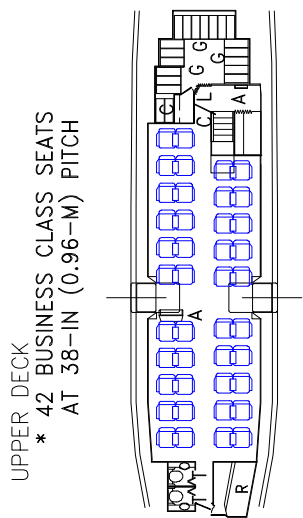

MAIN DECK - COMBI LOAD

- * 21 FIRST CLASS SEATS AT 61-IN (1.55-M) PITCH
- * 35 BUSINESS CLASS SEATS AT 38-IN (0.96-M) PITCH
- * 168 ECONOMY CLASS SEATS AT 32-IN (0.81-M) PITCH
- * 7 PALLETS

2.4.4 INTERIOR ARRANGEMENTS - PASSENGER/CARGO CONFIGURATION
 MODEL 747-400 COMBI

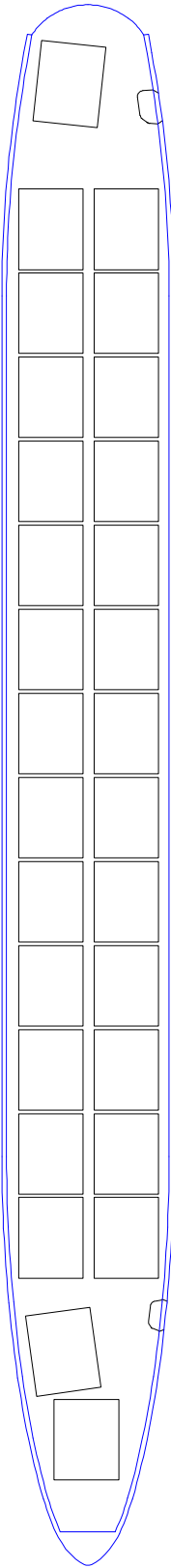

* 29 10-FT (3-M) CONTAINERS

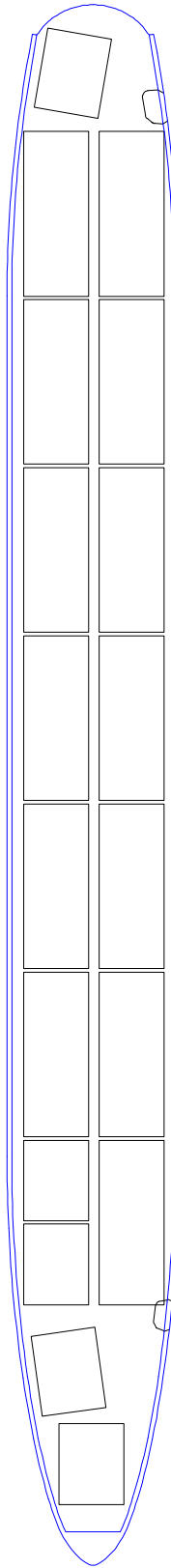

* 13 20-FT (6-M) CONTAINERS
* 5 10-FT (3-M) CONTAINERS

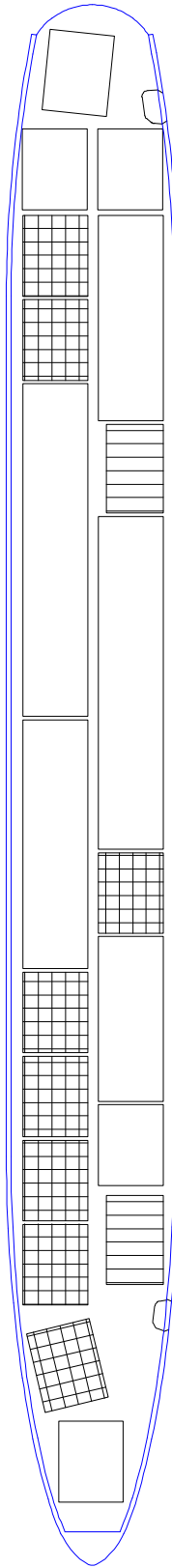

* RANDOM MIX OF CARGO PALLETS
AND CONTAINERS UP TO 40 FT (12 M)

2.4.5 INTERIOR ARRANGEMENTS - MAIN DECK CARGO
MODEL 747-400 FREIGHTER, -400ER FREIGHTER

- A ATTENDANT
- T TOILET
- S STORAGE
- G GALLEY

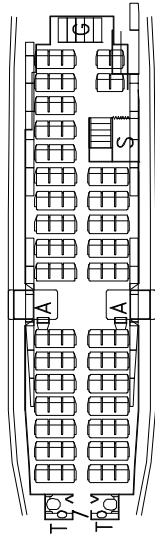

UPPER DECK

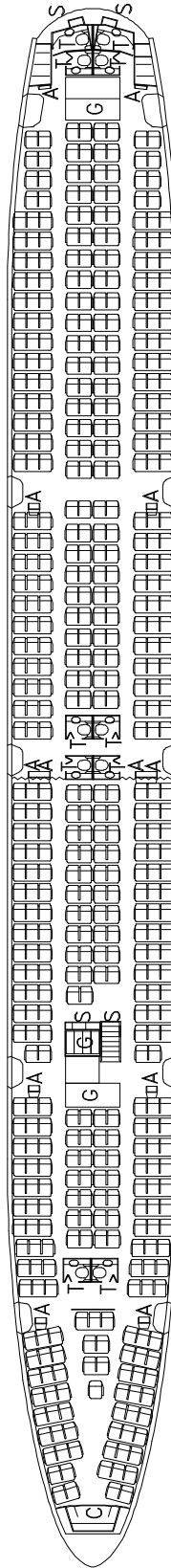

MAIN DECK

* 539 ECONOMY CLASS SEATS AT 31-IN (0.79 M) OR 32-IN (0.81-M) PITCH

UPPER DECK

* 85 ECONOMY CLASS SEATS AT 31-IN (0.79-M) OF 32-IN (0.81-M) PITCH

2.4.6 INTERIOR ARRANGEMENTS - HIGH-DENSITY SEATING CONFIGURATION
 MODEL 747-400 DOMESTIC

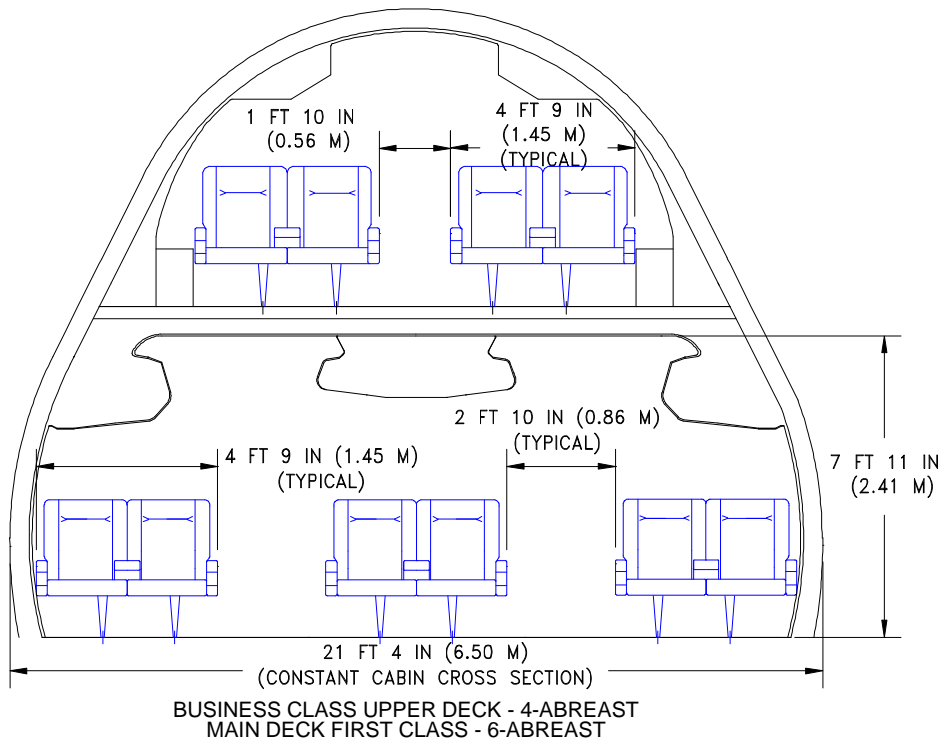
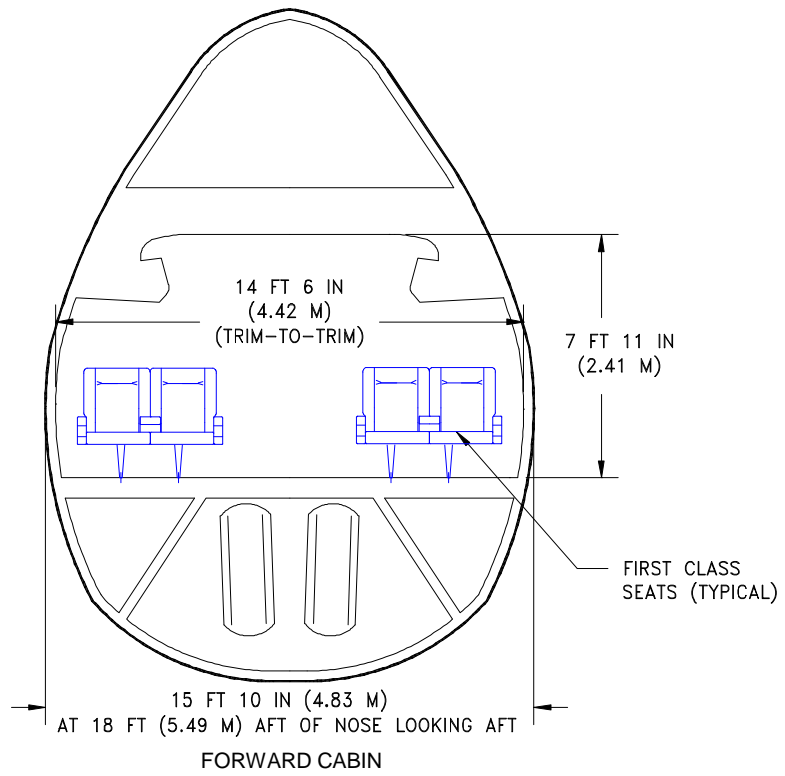

2.5.1 CABIN CROSS-SECTIONS - FIRST AND BUSINESS CLASS SEATS
MODEL 747-400

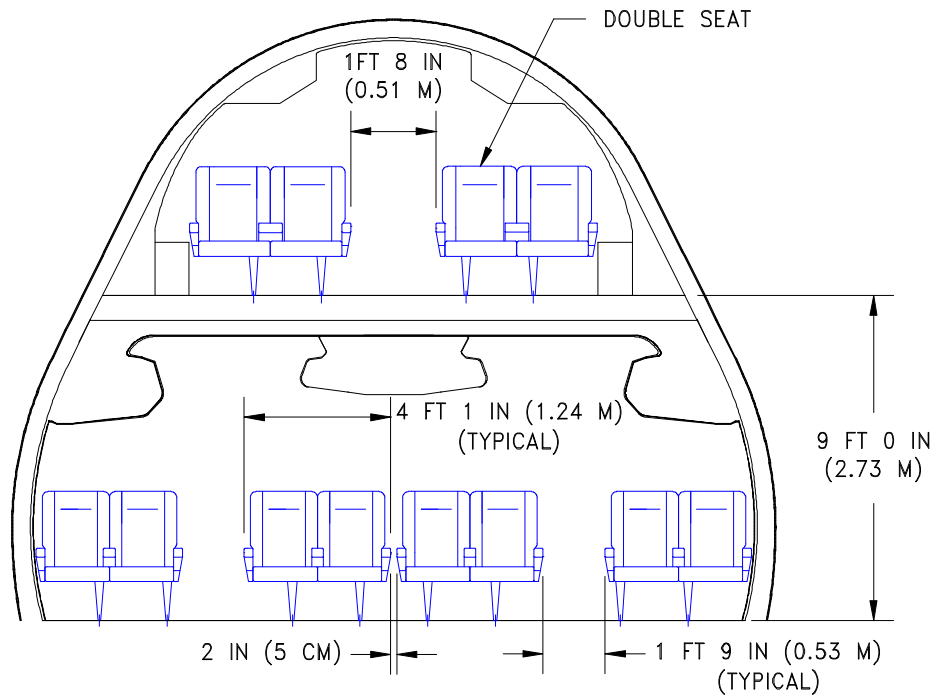

UPPER DECK - 4-ABREAST
 MAIN DECK - 8-ABREAST

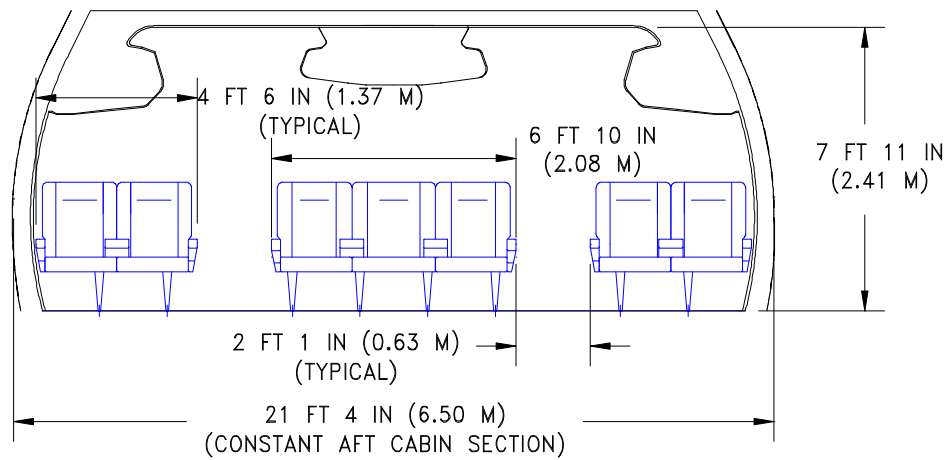

MAIN DECK - 7-ABREAST

2.5.2 CABIN CROSS-SECTIONS - BUSINESS CLASS SEATS

MODEL 747-400

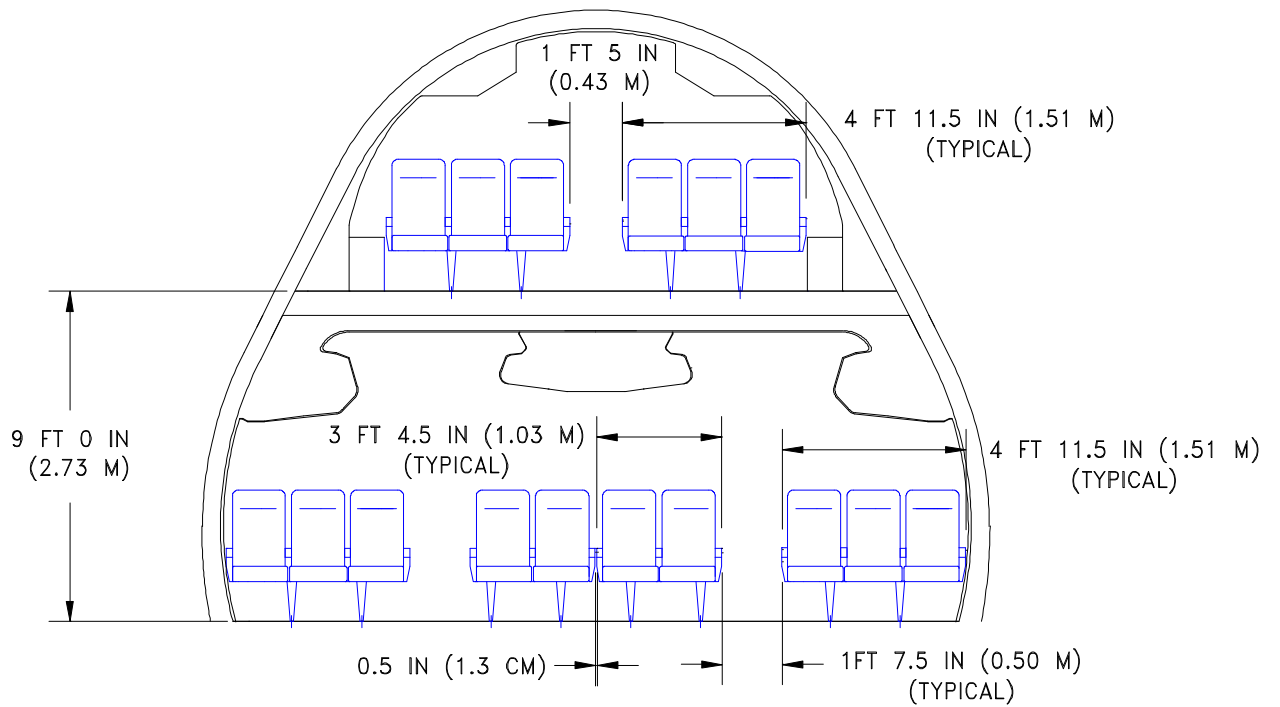

UPPER DECK - 6-ABREAST
 MAIN DECK - 10-ABREAST

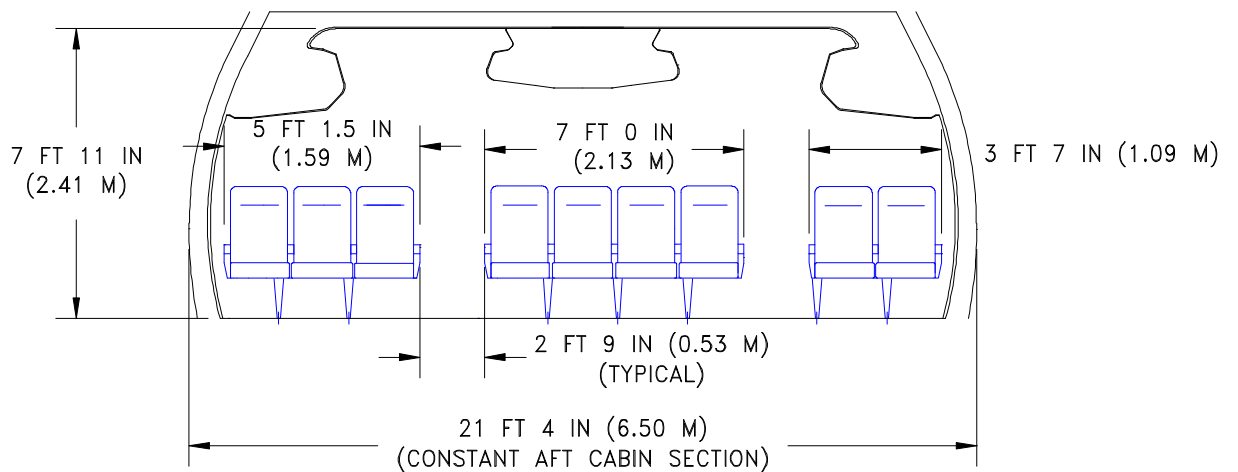

MAIN DECK - 9-ABREAST

2.5.3 CABIN CROSS-SECTIONS - ECONOMY CLASS SEATS
 MODEL 747-400

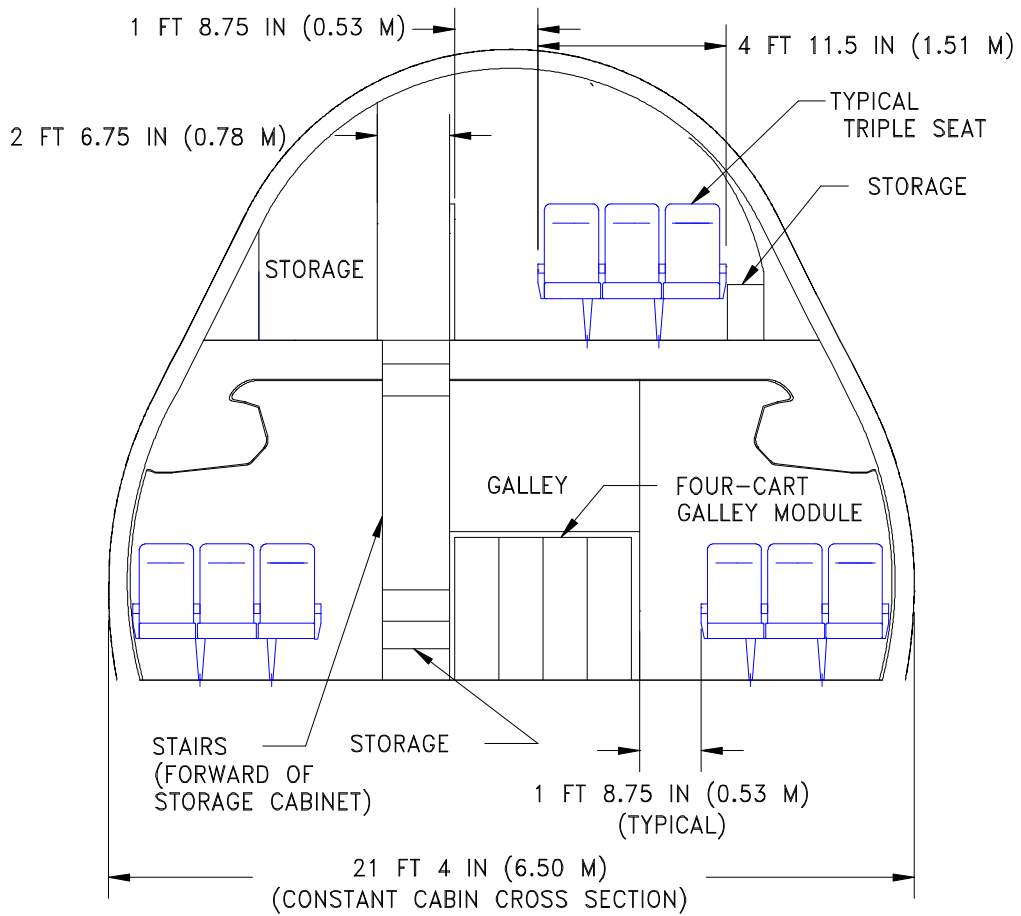

SECTION THROUGH STAIRS
(VIEW LOOKING FORWARD)

2.5.4 CABIN CROSS-SECTIONS - GALLEY AND STAIRS
MODEL 747-400

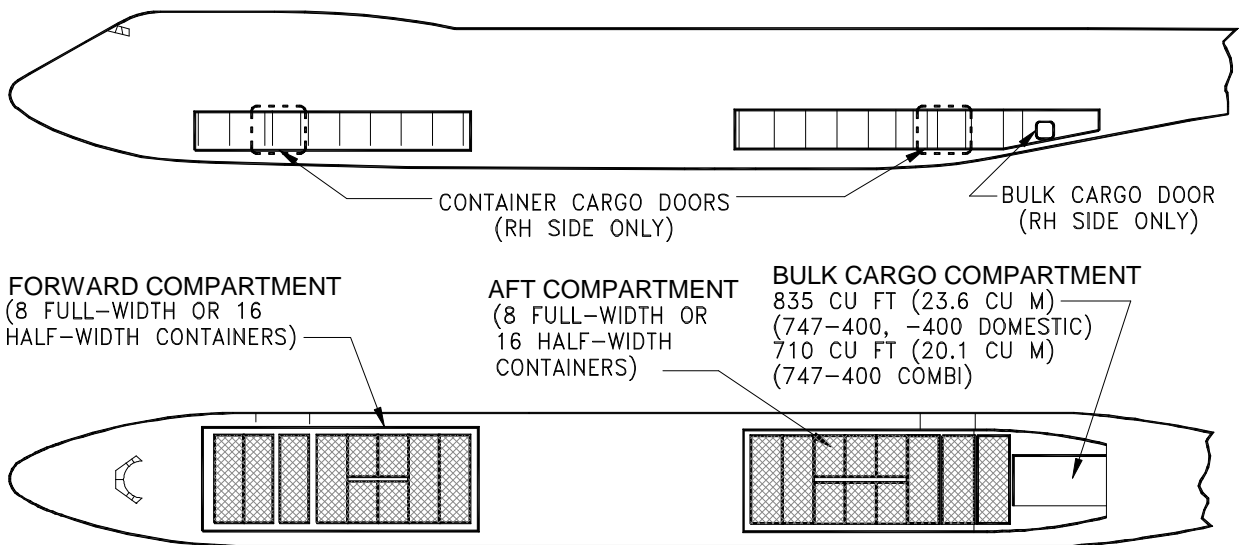

FORWARD COMPARTMENT
(8 FULL-WIDTH OR 16
HALF-WIDTH CONTAINERS)

AFT COMPARTMENT
(8 FULL-WIDTH OR
16 HALF-WIDTH
CONTAINERS)

BULK CARGO COMPARTMENT
835 CU FT (23.6 CU M)
(747-400, -400 DOMESTIC)
710 CU FT (20.1 CU M)
(747-400 COMBI)

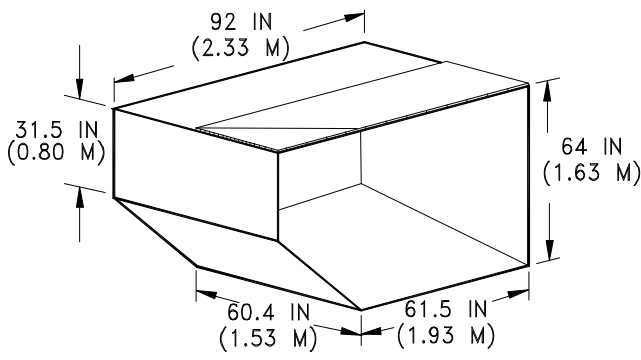

HALF-WIDTH CONTAINER (LD1)

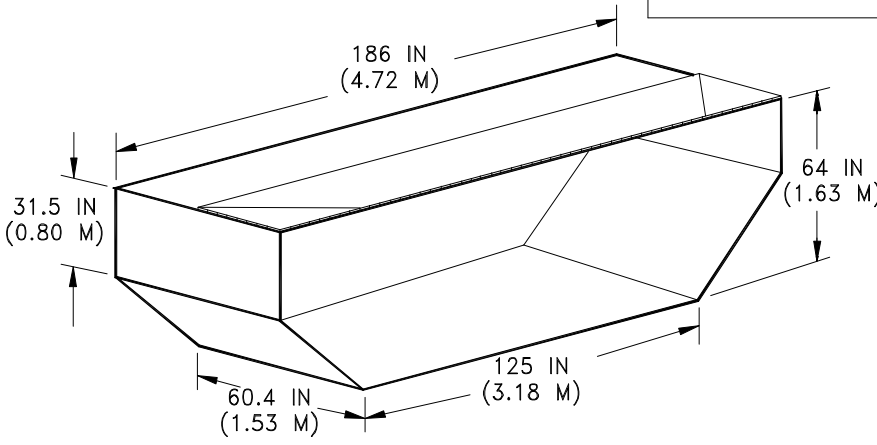

FULL-WIDTH CONTAINER (LD2)

CONTAINER DATA		
	HALF-WIDTH	FULL-WIDTH
INTERNAL VOLUME PER CONTAINER	173 CU FT 4.9 CU M	350 CU FT 9.9 CU M
TARE WEIGHT	270 LB 123 KG	470 LB 213 KG
MAXIMUM CARGO WEIGHT PER CONTAINER	3,230 LB 1,467 KG	6,530 LB 2,965 KG
MAXIMUM GROSS WEIGHT PER CONTAINER	3,500 LB 1,590 KG	7,000 LB 3,180 KG
TOTAL VOLUME OF 16 FULL-WIDTH CONTAINERS IS 5,600 CU FT (158.6 CU M)		
GROSS WEIGHT FOR 16 FULL-WIDTH OR 32 HALF-WIDTH CONTAINERS IS 112,000 LB (50,802 KG)		

- NOTES:**
1. CONTAINER WEIGHT AND DATA ARE TYPICAL. CONSULT USING AIRLINE FOR SPECIFIC DATA.
 2. OPTIONS ARE OFFERED FOR CARRIAGE OF CERTAIN STANDARD MILITARY AND COMMERCIAL PALLETS IN CONTAINER COMPARTMENTS.

2.6.1 LOWER CARGO COMPARTMENTS - CONTAINERS AND BULK CARGO
MODEL 747-400, -400 COMBI, -400 DOMESTIC

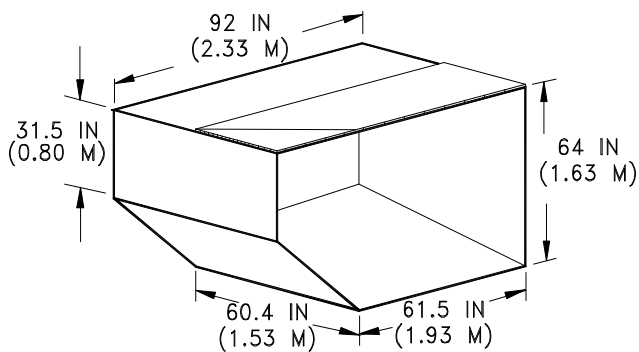
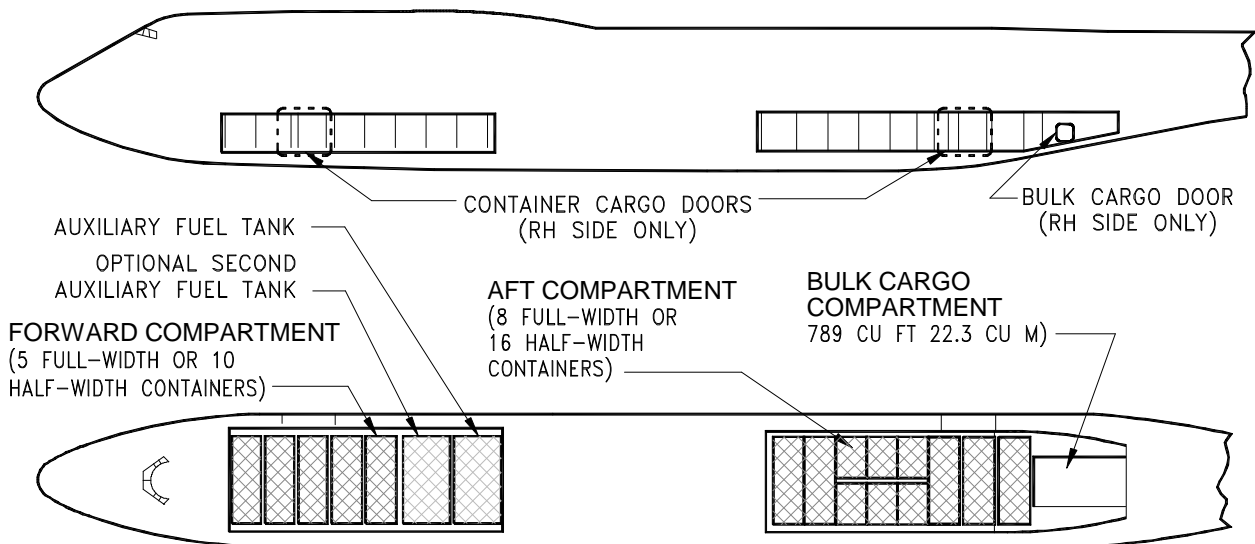

HALF-WIDTH CONTAINER (LD1)

CONTAINER DATA		
CONTAINER DATA	HALF-WIDTH	FULL-WIDTH
INTERNAL VOLUME PER CONTAINER	173 CU FT 4.9 CU M	350 CU FT 9.9 CU M
TARE WEIGHT	270 LB 123 KG	470 LB 213 KG
MAXIMUM CARGO WEIGHT PER CONTAINER	3,230 LB 1,467 KG	6,530 LB 2,965 KG
MAXIMUM GROSS WEIGHT PER CONTAINER	3,500 LB 1,590 KG	7,000 LB 3,180 KG
TOTAL VOLUME OF 13 FULL-WIDTH CONTAINERS IS 4,550 CU FT (128.8 CU M)		
GROSS WEIGHT FOR 13 FULL-WIDTH OR 26 HALF-WIDTH CONTAINERS IS 91,000 LB (35,872 KG)		

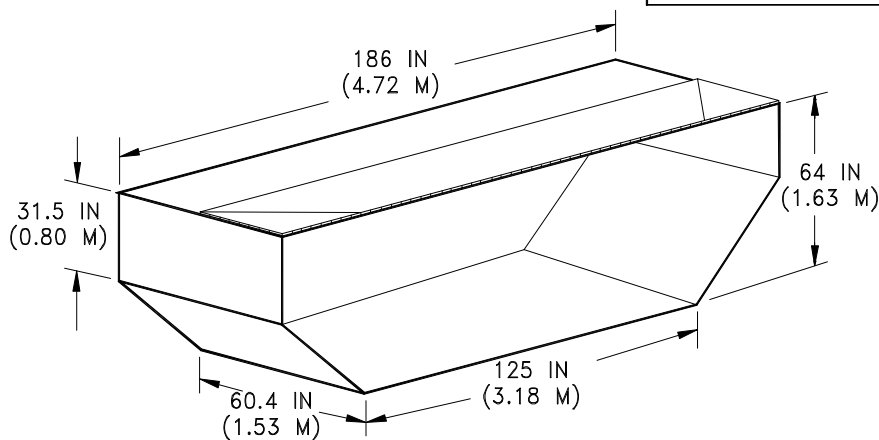

FULL-WIDTH CONTAINER (LD2)

NOTES:

1. CONTAINER WEIGHT AND DATA ARE TYPICAL. CONSULT USING AIRLINE FOR SPECIFIC DATA.
2. OPTIONS ARE OFFERED FOR CARRIAGE OF CERTAIN STANDARD MILITARY AND COMMERCIAL PALLETS IN CONTAINER COMPARTMENTS.

2.6.2 LOWER CARGO COMPARTMENTS - CONTAINERS AND BULK CARGO

MODEL 747-400ER

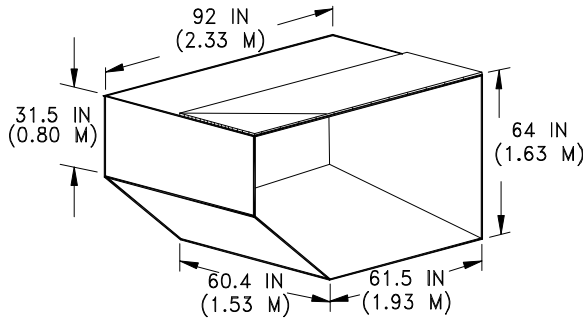
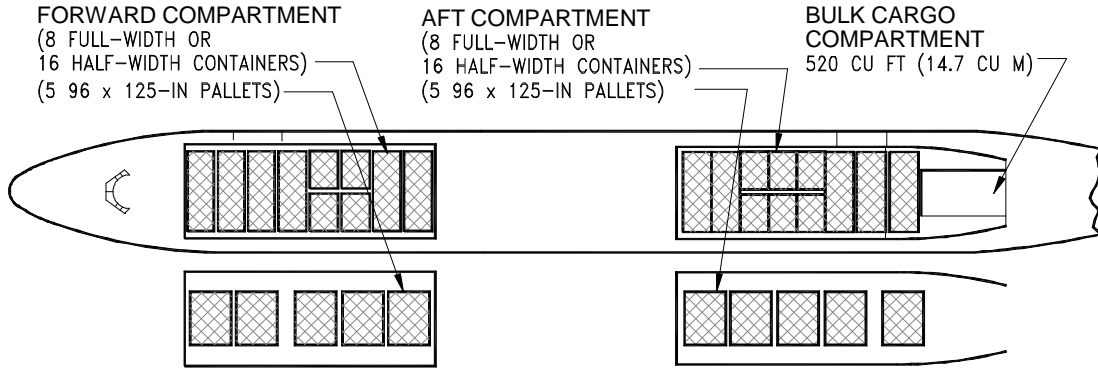

HALF-WIDTH CONTAINER (LD1)

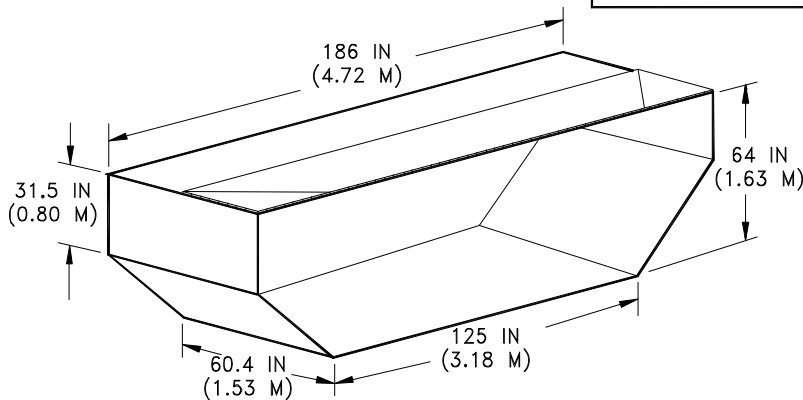

FULL-WIDTH CONTAINER (LD2)

CONTAINER DATA		
CONTAINER DATA	HALF-WIDTH	FULL-WIDTH
INTERNAL VOLUME PER CONTAINER	173 CU FT 4.9 CU M	350 CU FT 9.9 CU M
TARE WEIGHT	270 LB 123 KG	470 LB 213 KG
MAXIMUM CARGO WEIGHT PER CONTAINER	3,230 LB 1,467 KG	6,530 LB 2,965 KG
MAXIMUM GROSS WEIGHT PER CONTAINER	3,500 LB 1,590 KG	7,000 LB 3,180 KG
TOTAL VOLUME OF 16 FULL-WIDTH CONTAINERS IS 5,600 CU FT (158.6 CU M)		
GROSS WEIGHT FOR 16 FULL-WIDTH OR 32 HALF-WIDTH CONTAINERS IS 112,000 LB (50,802 KG)		

NOTES:

1. CONTAINER WEIGHT AND DATA ARE TYPICAL. CONSULT USING AIRLINE FOR SPECIFIC DATA.
2. OPTIONS ARE OFFERED FOR CARRIAGE OF CERTAIN STANDARD MILITARY AND COMMERCIAL PALLETS IN CONTAINER COMPARTMENTS.

2.6.3 LOWER CARGO COMPARTMENTS - CONTAINERS AND BULK CARGO

MODEL 747-400 FREIGHTER, -400ER FREIGHTER

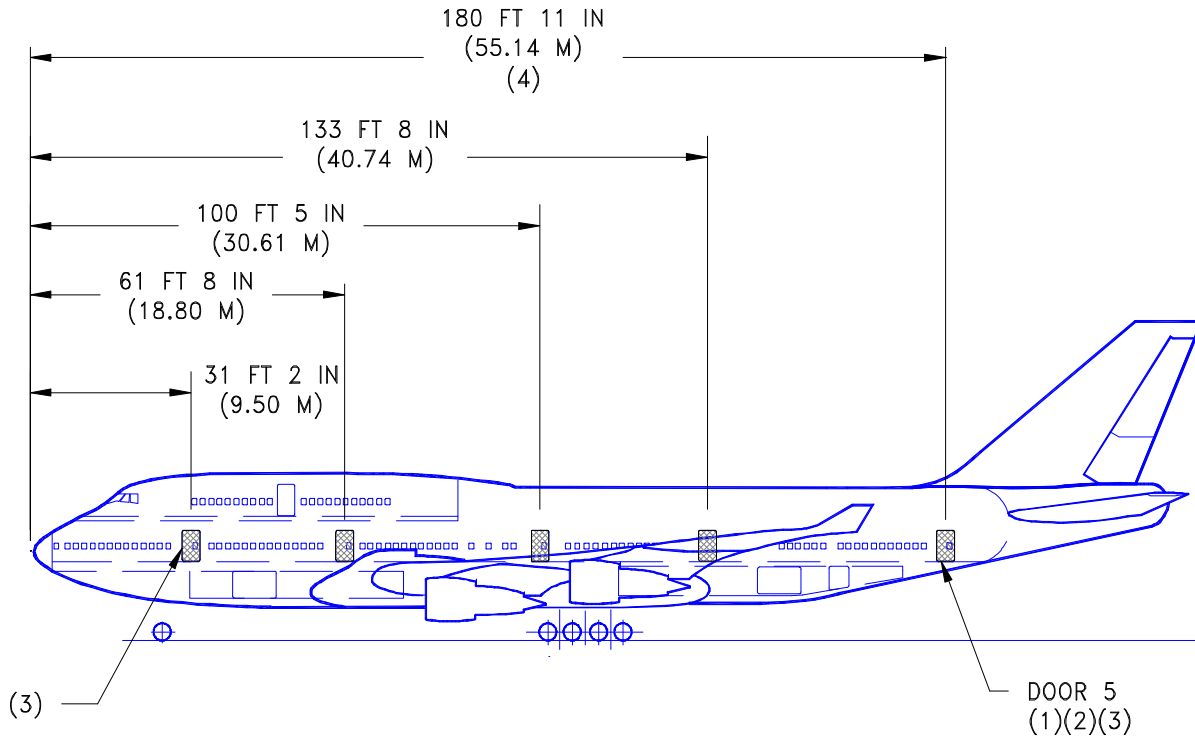

NOTES:

- (1) 10 PASSENGER DOORS – 5 EACH SIDE
DOOR OPENING SIZE = 42 BY 76 IN (1.07 BY 1.93 M)
OVERALL DOOR SIZE = 47 BY 76 IN (1.19 BY 1.93 M)
- (2) SEE SECTION 2.3 FOR DOOR SILL HEIGHTS
- (3) LH DOOR NO. 1 AND NO. 5 ON 747-400 FREIGHTER, -400ER FREIGHTER
- (4) 180 FT 5 IN (55.00 M) ON 747-400 FREIGHTER, -400ER FREIGHTER

2.7.1 DOOR CLEARANCES - MAIN ENTRY DOOR LOCATIONS

MODEL 747-400

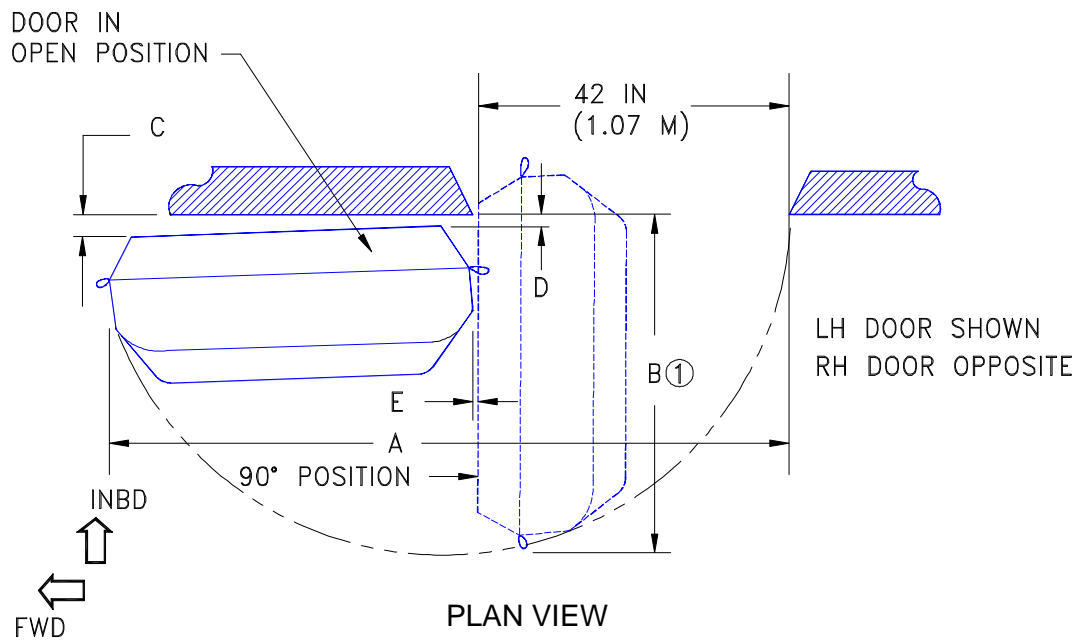

	DOOR NUMBER			
	1 ②	2	3	4
A	7 FT 6 IN	7 FT 6 IN	7 FT 6 IN	7 FT 6 IN
	2.29 M	2.29 M	2.29 M	2.29 M
B ①	3 FT 9 IN	3 FT 10 IN	3 FT 10 IN	3 FT 10 IN
	1.14 M	1.17 M	1.17 M	1.17 M
C	4 IN	3 IN	3 IN	3 IN
	0.102 M	0.076 M	0.076 M	0.076 M
D	1 IN	1 IN	1 IN	1 IN
	0.025 M	0.025 M	0.025 M	0.025 M
E	1 IN	1 IN	1 IN	1 IN
	0.025 M	0.025 M	0.025 M	0.025 M

① MEASURED AT DOOR OPENING CENTERLINE AT DOOR SILL LEVEL AT 90° FROM AIRPLANE CENTERLINE.

② LH SIDE ONLY ON 747-400 FREIGHTER, -400ER FREIGHTER.

2.7.2 DOOR CLEARANCES - MAIN ENTRY DOORS 1-4 (PLAN VIEW)

MODEL 747-400

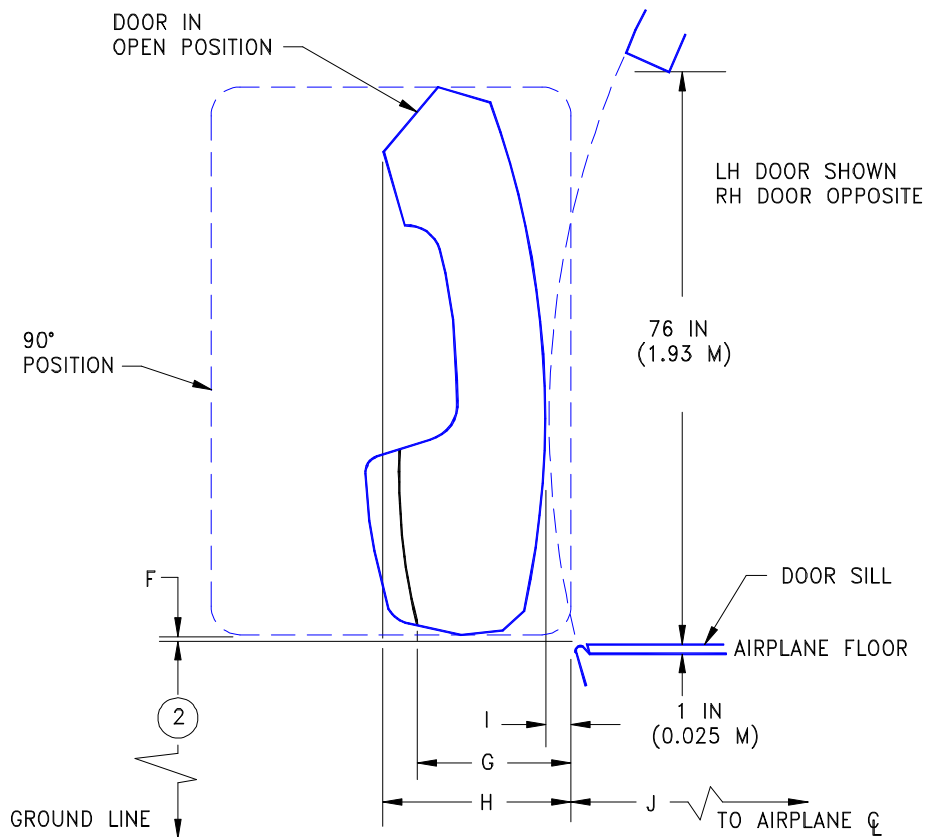

VIEW LOOKING FORWARD

	DOOR NUMBER			
	1 (3)	2	3	4
F	2 IN (0.05 M)			
G (1)	1 FT 7 IN (0.48 M)	1 FT 10 IN (0.56 M)		
H (1)	1 FT 11 IN (0.58 M)	2 FT (0.61 M)	1 FT 9 IN (0.53 M)	2 FT (0.61 M)
I (1)	1 IN (0.025 M)	3 IN (0.076 M)	0	3 IN (0.076 M)
J (1)	9 FT 6 IN (2.90 M)	10 FT 5 IN (3.18 M)	10 FT 8 IN (3.25 M)	10 FT 5 IN (3.18 M)

- (1) MEASURED AT DOOR OPENING CENTERLINE AT DOOR SILL LEVEL AT 90° FROM AIRPLANE CENTERLINE
- (2) SEE SEC. 2.3 FOR DOOR SILL HEIGHTS
- (3) LH SIDE ONLY ON 747-400 FREIGHTER, -400ER FREIGHTER

2.7.3 DOOR CLEARANCES - MAIN ENTRY DOORS 1-4 (SIDE VIEW)
 MODEL 747-400

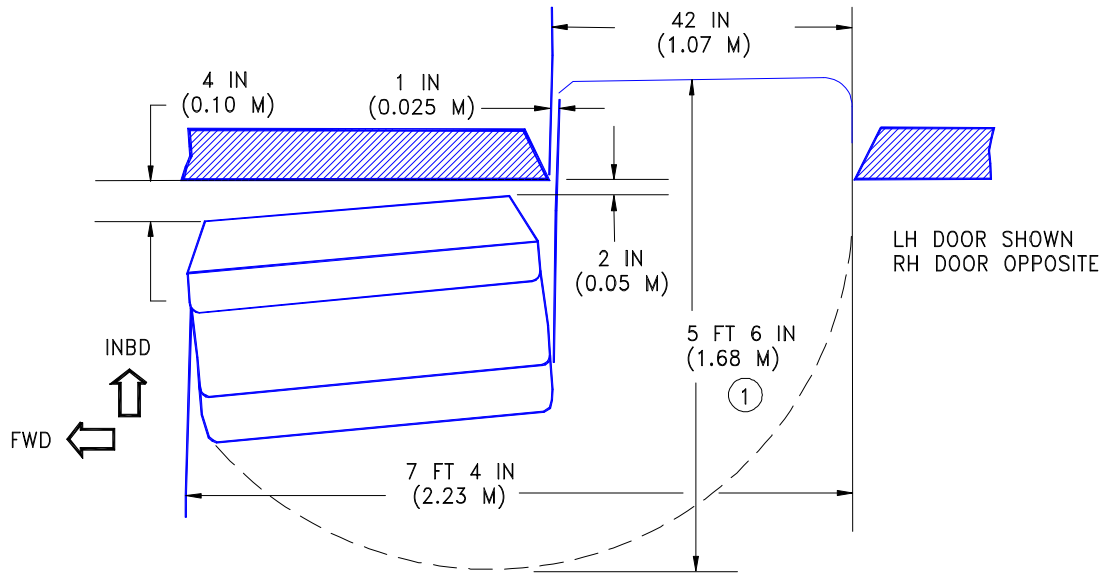

PLAN VIEW

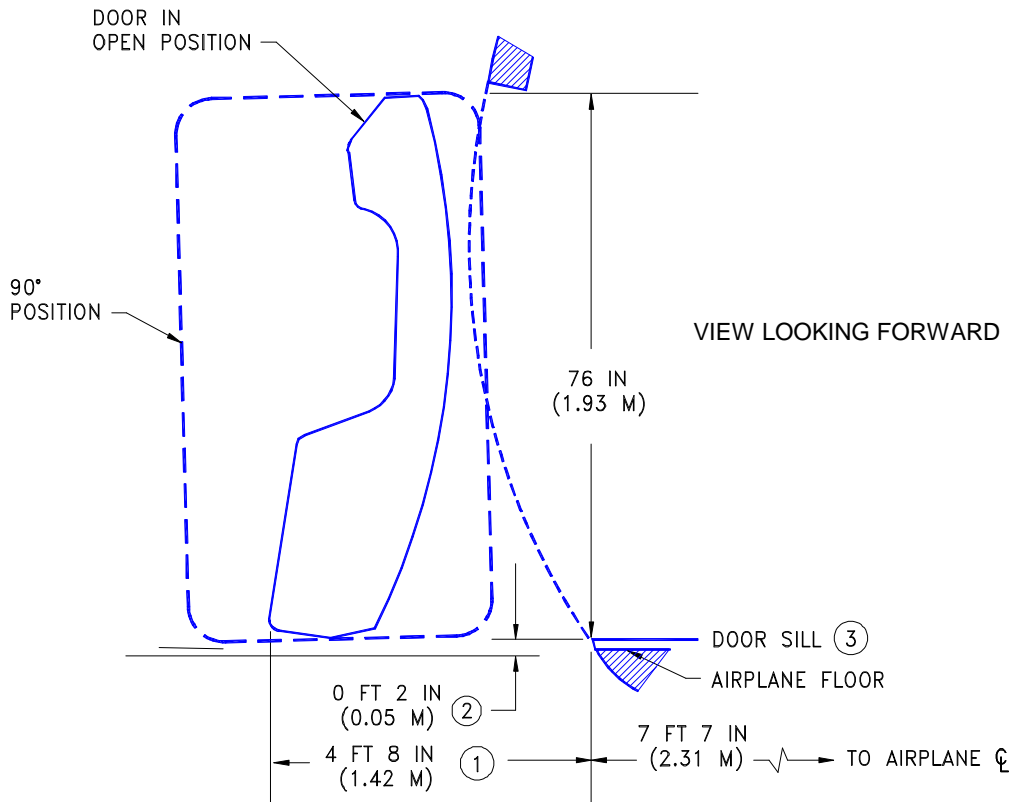

- ① MEASURED AT DOOR OPENING CENTERLINE AT DOOR SILL LEVEL AT 90° FROM AIRPLANE CENTERLINE
- ② DOOR HINGE IS INCLINED 3 DEGREES FROM VERTICAL
- ③ SEE SEC. 2.3 FOR DOOR SILL HEIGHTS
- ④ LH SIDE ONLY ON 747-400 FREIGHTER, -400ER FREIGHTER

2.7.4 DOOR CLEARANCES - MAIN ENTRY DOOR 5
 MODEL 747-400

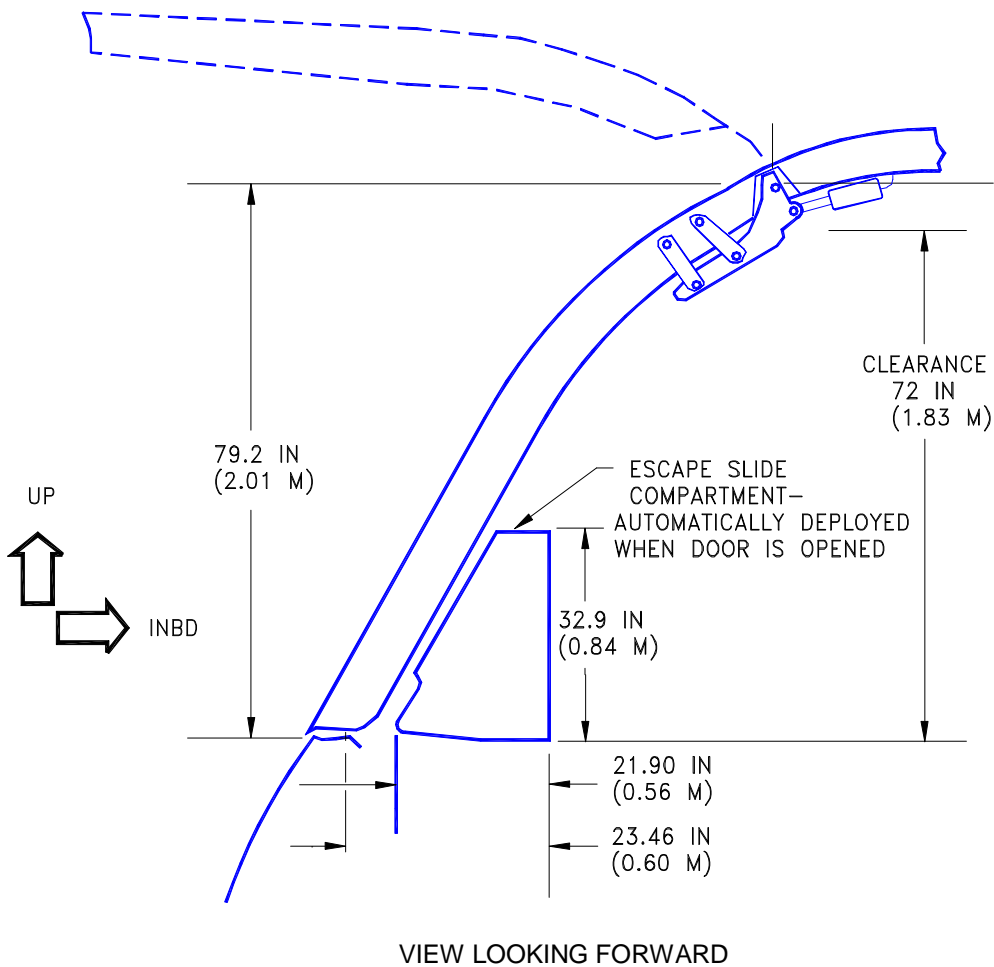
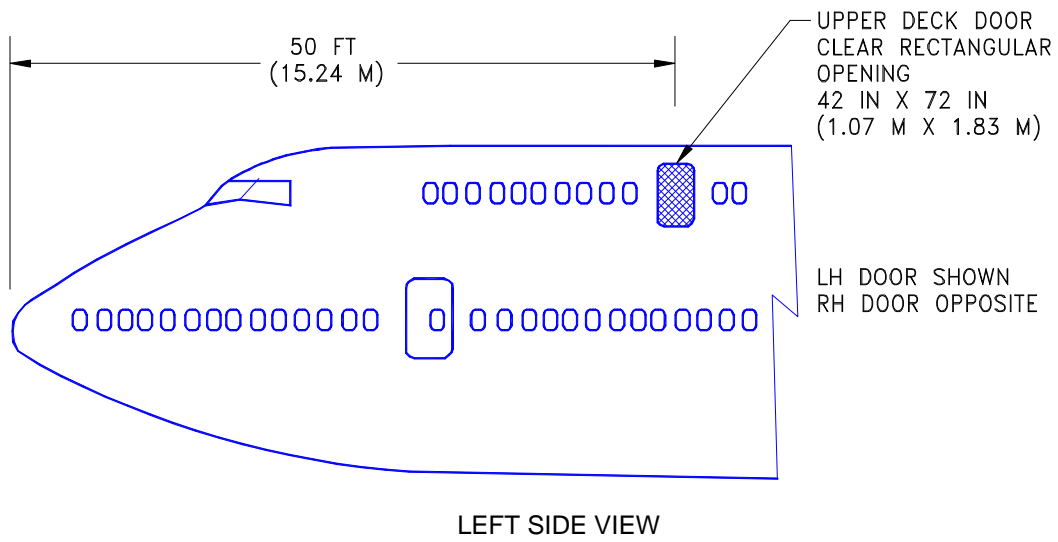

2.7.5 DOOR CLEARANCES - UPPER DECK EMERGENCY EXIT DOOR
MODEL 747-400

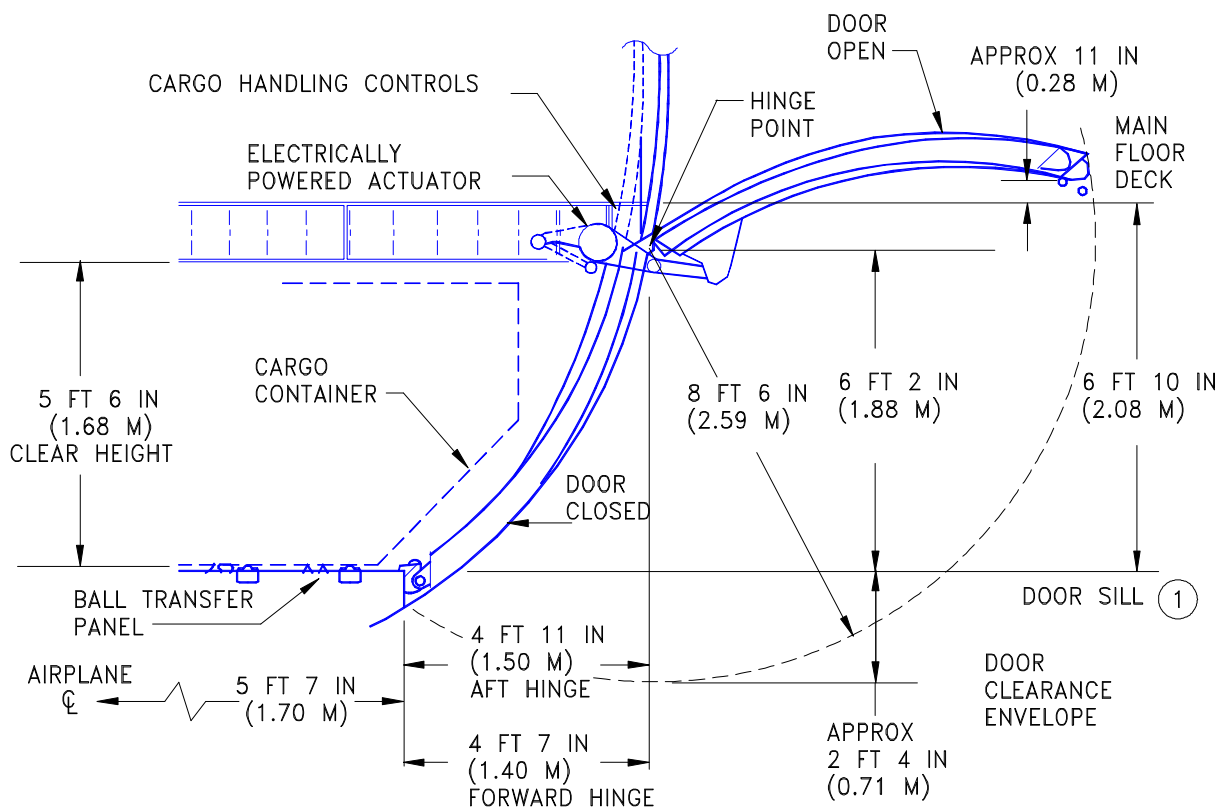
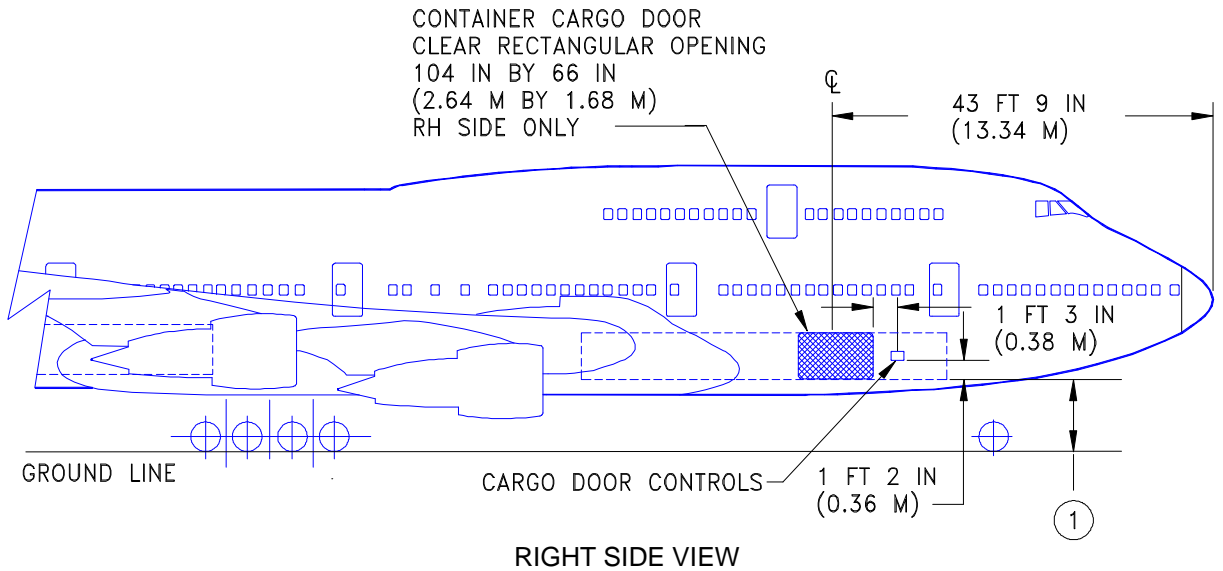

CONTAINER CARGO DOOR - VIEW LOOKING FORWARD

① SEE SECTION 2.3 FOR DOOR SILL HEIGHTS

2.7.6 DOOR CLEARANCES - LOWER FORWARD CARGO COMPARTMENT
MODEL 747-400

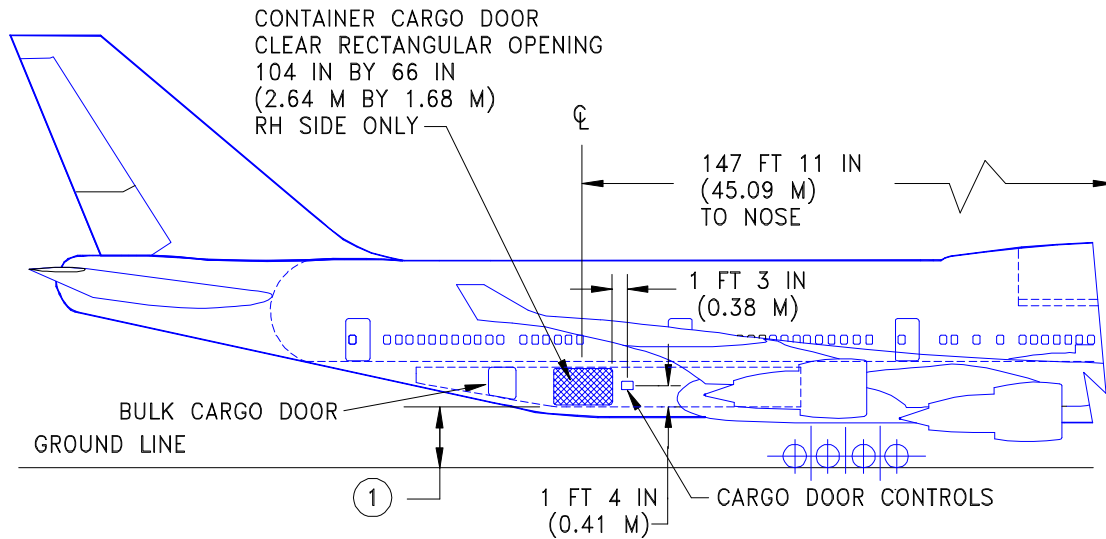

RIGHT SIDE VIEW

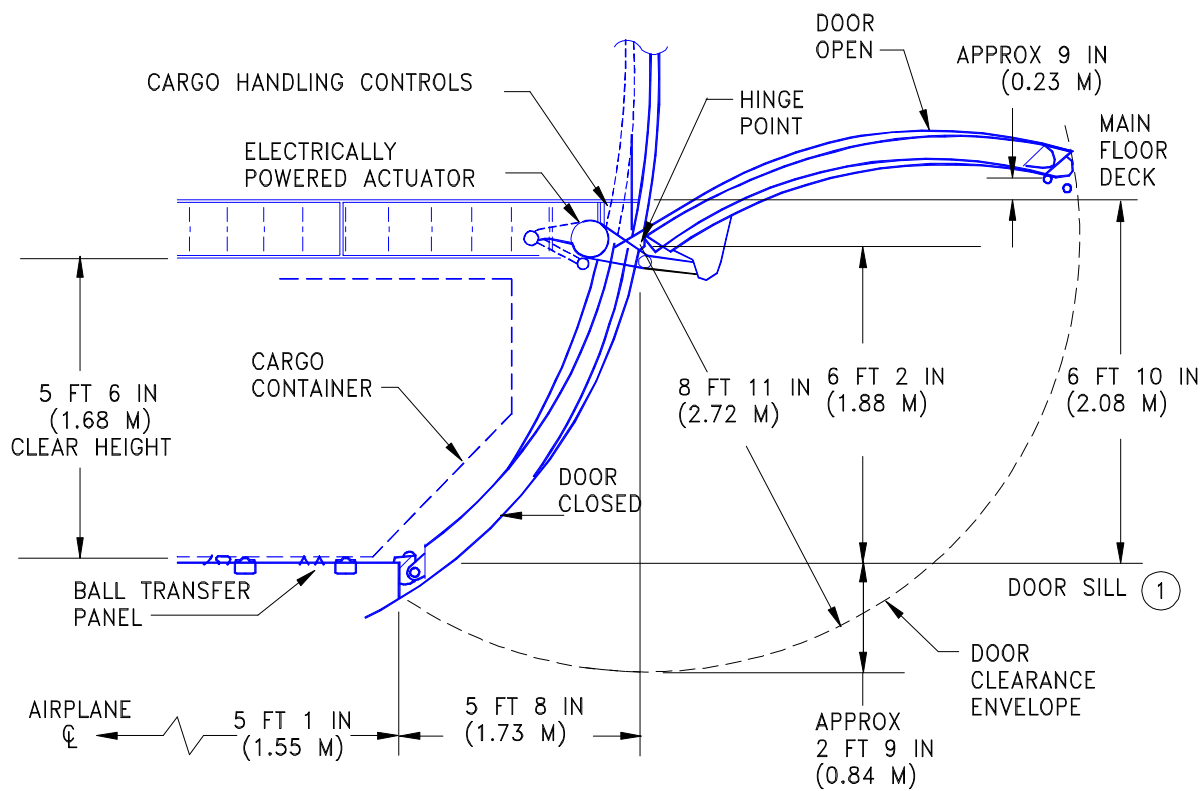

CONTAINER CARGO DOOR - VIEW LOOKING FORWARD

① SEE SECTION 2.3 FOR DOOR SILL HEIGHTS

2.7.7 DOOR CLEARANCES - LOWER AFT CARGO COMPARTMENT

MODEL 747-400

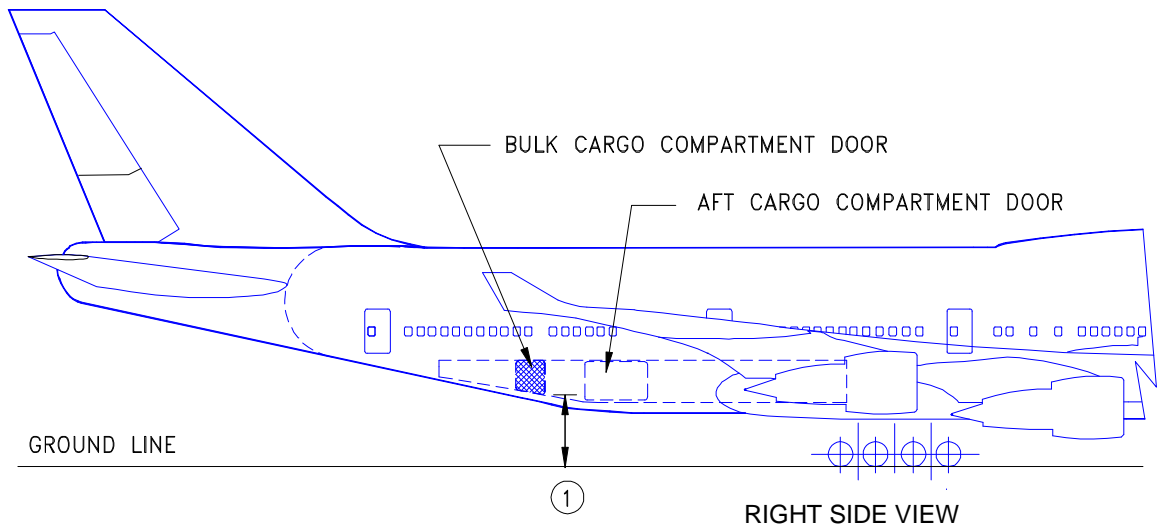

① SEE SECTION 2.3 FOR DOOR SILL HEIGHTS

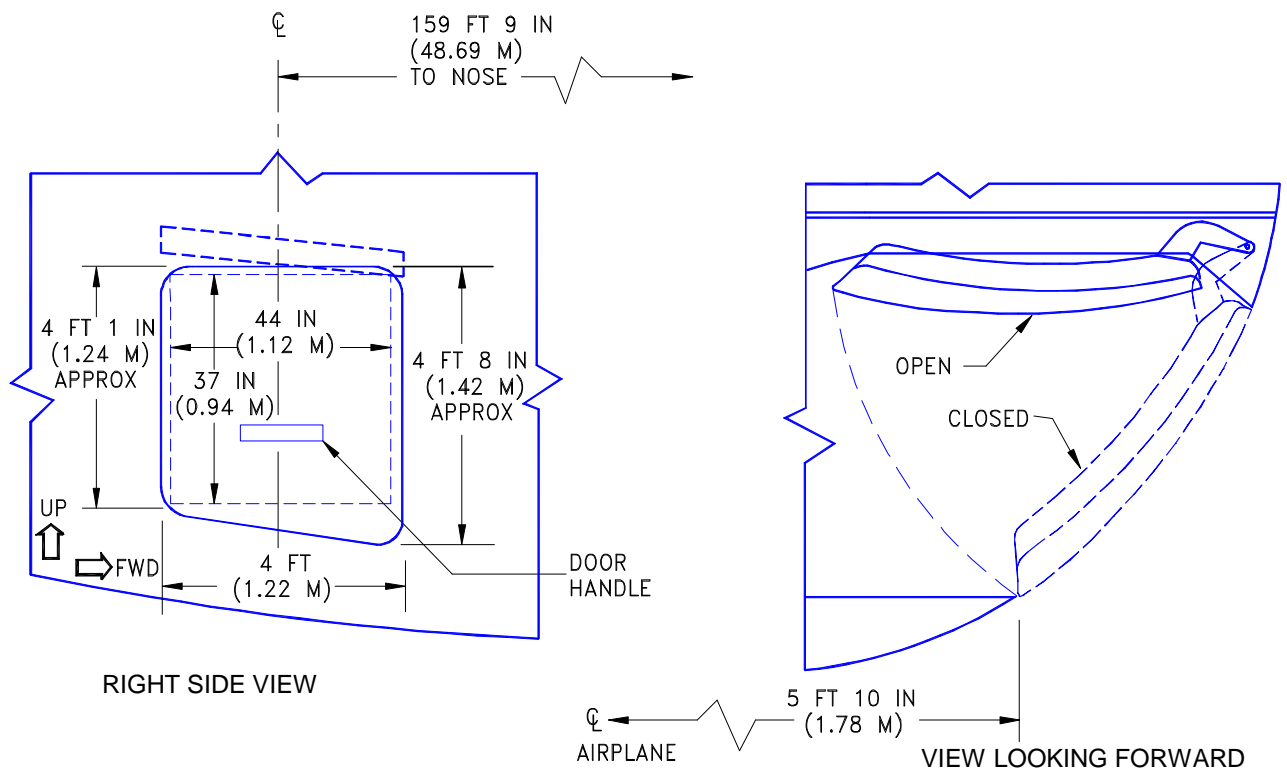

2.7.8 DOOR CLEARANCES - BULK CARGO COMPARTMENT
MODEL 747-400

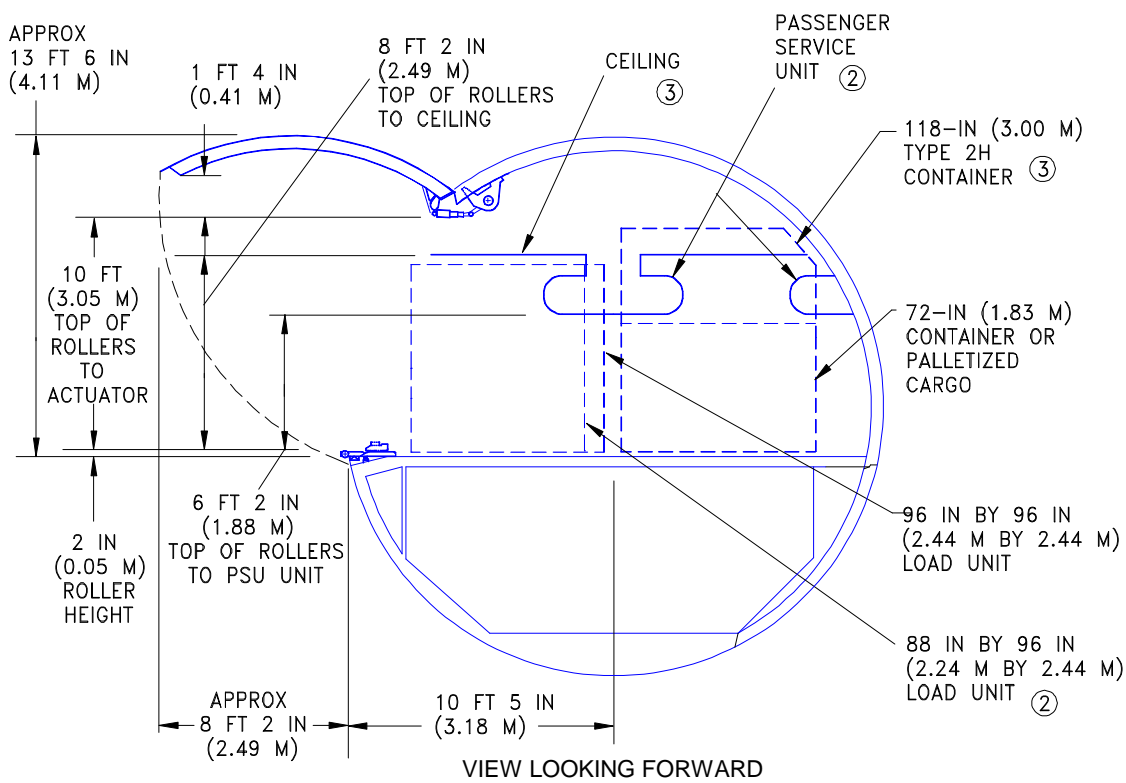
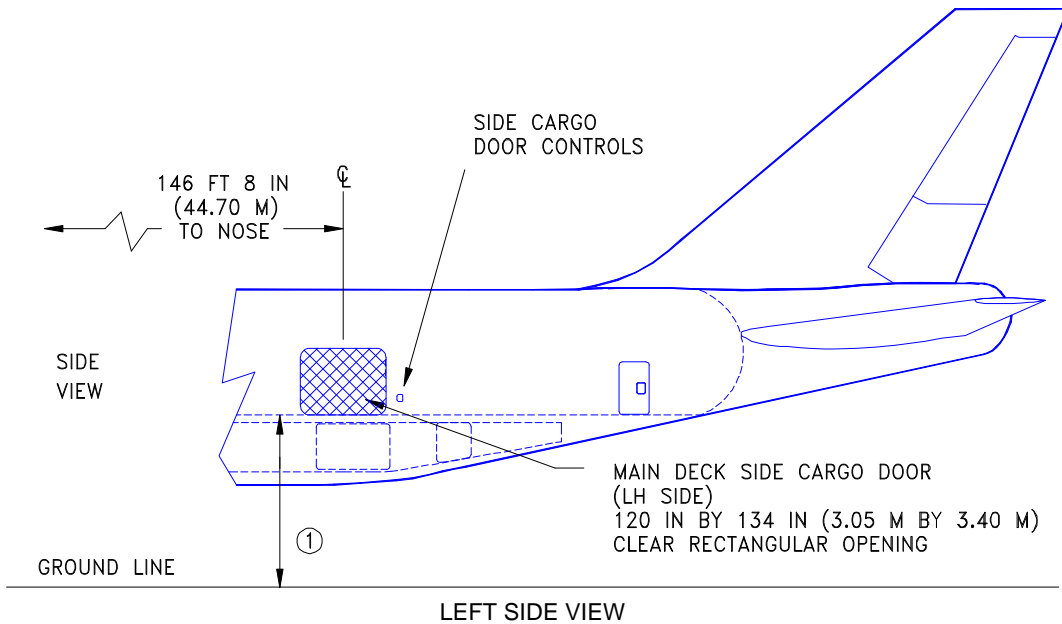

- ① SEE SECTION 2.3 FOR DOOR SILL HEIGHTS
- ② PSU'S ARE REMOVED WHEN 96-IN HIGH CONTAINER OR PALLET IS LOADED
- ③ CEILING IS REMOVED WHEN TYPE 2H CONTAINER IS LOADED

2.7.9 DOOR CLEARANCES - MAIN DECK CARGO DOOR
 MODEL 747-400 COMBI, -400 FREIGHTER, -400ER FREIGHTER

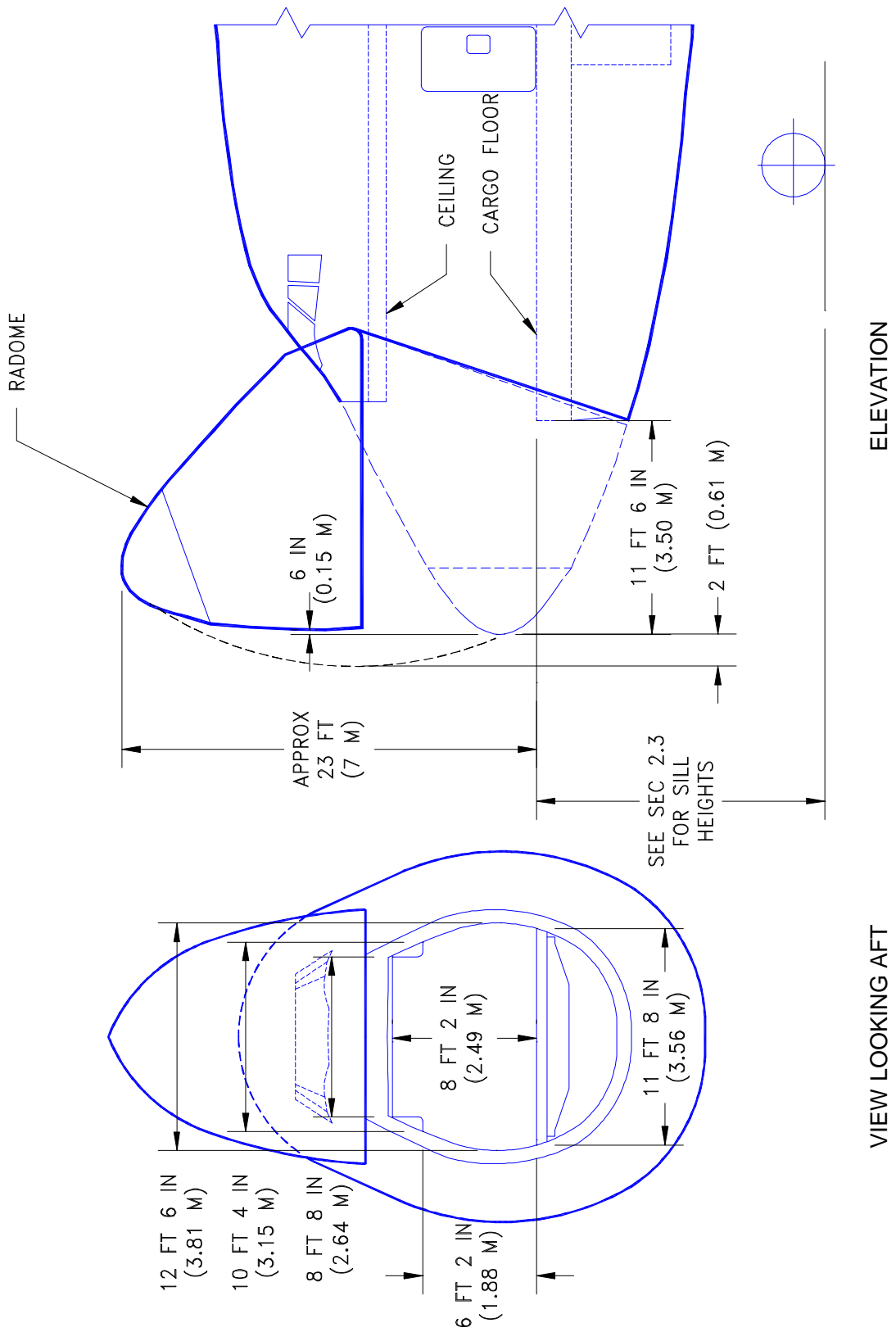

2.7.10 DOOR CLEARANCES - NOSE CARGO DOOR
 MODEL 747-400 FREIGHTER, -400ER FREIGHTER

THIS PAGE INTENTIONALLY LEFT BLANK