

~~SECRET~~

ARMY AIR FORCES HISTORICAL STUDIES: No. 13

UNCLASSIFIED

Classification Cancelled
By Authority of Director,
Research Studies Institute
By REDA
Date SEP 18 1959

RETURN TO
USAF Historical Archives
ASIS(AHAF-A)
Maxwell AFB, Ala 36112

THE DEVELOPMENT OF TACTICAL DOCTRINES AT AAFSAT & AAFTAC

DO NOT LOAN

The original of this monograph and the documents from which it was written are in the USAF Historical Division, Archives Branch, Bldg. 914, Maxwell Air Force Base, Alabama.

AIR HISTORICAL OFFICE
Headquarters, Army Air Forces

7-15-13
10467605

UNCLASSIFIED

SCANNED BY ISA

UNCLASSIFIED

<p>100-100000-100000</p>	<p>REFUND TO</p>
--------------------------	------------------

Director
 Aerospace Studies Inst
 AFIT, Dayton, Ohio
 Maxwell AFB, Alabama

UNCLASSIFIED

0457505
 1 - 10-10

ARMY AIR FORCES HISTORICAL STUDIES: No. 13

UNCLASSIFIED

THE DEVELOPMENT OF TACTICAL DOCTRINES

AT

AAFSAT AND AAFTAC

Prepared by
Assistant Chief of Air Staff, Intelligence
Historical Division
July 1944

UNCLASSIFIED

*Classification
Restricted to
2671000
2671000
146*

UNCLASSIFIED

FOREWORD

It is the desire of the President, the Secretary of War, and the Commanding General, Army Air Forces, that a solid record of the experiences of the AAF be compiled. This is one of a series of studies prepared as a "first narrative" in the projected overall history of the Army Air Forces.

The decision to make the information contained herein available for staff and operational use without delay has prevented recourse to some primary sources. Readers familiar with this subject matter are invited to contribute additional facts, interpretations, and constructive suggestions.

This study will be handled in strict compliance with AR 380-5.



THOMAS D. WHITE
Brigadier General, U. S. Army
Assistant Chief of Air Staff,
Intelligence

Readers are requested to forward comments and criticisms, and to this end perforated sheets, properly addressed, are appended at the back of this study.

UNCLASSIFIED



4-5426, AF

UNCLASSIFIED

C O N T E N T S

INTRODUCTION 1

I THE ORGANIZATIONAL PROBLEM

 Headquarters Organization of Tactical Development,
 1939-1943 6

 The School of Applied Tactics and the Army Air
 Forces Board 22

II THE DEVELOPMENT OF TACTICS

 The Establishment of the Tactical Problem 34

 The Development of Tactics 45

III TACTICAL INTELLIGENCE

 Assembling and Use of Tactical Information 60

 Dissemination of Tactics 81

IV CONCLUSIONS 91

GLOSSARY OF ABBREVIATIONS 99

BIBLIOGRAPHY 100

INDEX 103

UNCLASSIFIED

CONFIDENTIAL

~~CONFIDENTIAL~~

117-1455-3

ILLUSTRATIONS

<u>Chart</u>	<u>Following</u>
1. Army Air Forces after Reorganization of June 20, 1941 [At time of Pearl Harbor]	8
2. Army Air Forces Organization, March 9, 1942 [Establishment of the directorates].	9
3. Organization of Army Air Forces, January 25, 1943	12
4. Army Air Forces Organization, March 29, 1943	17
5. Organizational Chart--Army Air Forces School of Applied Tactics	29
6. Organization Chart for Executive Director of Army Air Forces Board	31

117-1455-3

~~CONFIDENTIAL~~

UNCLASSIFIED

The Development of Tactical Doctrines at AAFSAT and AAFTAC

UNCLASSIFIED

~~CONFIDENTIAL~~

INTRODUCTION

Shortly after the close of World War I there was established in the Army Air Service a tactical school. During the course of nearly two decades, this school gradually assumed the functions of a true tactical center--that is, in addition to disseminating tactics through the instruction of especially selected officers it engaged in tactical development, test, and demonstration. Yet, when the United States declared war against the Axis powers, the Army Air Forces had no tactical center, nor even a tactical school. Indeed, it was more than 11 months after Pearl Harbor before the tactical school was reestablished as the Army Air Forces School of Applied Tactics. Meanwhile, tactical problems were dealt with almost at random by a number of Headquarters offices employing a variety of units in tactical development and test. The functions and facilities of the new tactical school in Orlando, Fla. were expanded gradually, and it was another 11 months before the organization was redesignated the Army Air Forces Tactical Center, thereby acknowledging its enlarged role. This study is an attempt to describe briefly just what the tactical problem was at various stages in the expansion of the Army Air Forces, how the problem was dealt with, and why it was handled in a particular way at a particular time.

The development of tactics is an essential function of any military organization. When the necessary materiel has been created, when the required number of personnel have been selected and trained, there arises the problem of how the two may best be employed in com-

~~CONFIDENTIAL~~

RESTRICTED
SECURITY INFORMATION

2

ination in the waging of war. Briefly, tactics is the art of using military force. Tactics, as distinguished from strategy, involves the techniques of warfare, whereas strategy concerns the ends toward which those techniques are applied. For example, it is the province of the strategist to decide whether a bomber force would better be employed in bombing an enemy's production and communications centers than in destroying his ammunition dumps and troop concentrations. It is the problem of the tactician to determine how the bombing mission may be conducted most effectively.

The modern army or air force which is unable to adapt its tactics to changing conditions of combat, or which is tardy in developing tactical devices that will insure the most effective use of available men and materiel, is certain to meet with reverses and is almost as certain to encounter ultimate defeat. How then may a modern army or air force secure for itself adequate adaptability in tactics? A number of considerations are fundamental to the problem:

1. The tactical need or opportunity must be perceived and defined promptly.
2. Elements of the situation which are not strictly tactical, but which involve questions of materiel or the training of personnel, must be assigned to be dealt with by appropriate agencies.
3. The tactical aspects of the situation must be defined and worked upon until a solution is reached.
4. Solutions to problems must be placed in the hands of the fighting men as promptly as possible and in such fashion as will insure their being adopted and applied. To the same end, alterations in fundamental tactical doctrine must be incorporated into the training of new soldiers as quickly as possible.

~~RESTRICTED~~

~~RESTRICTED~~
~~SECURITY INFORMATION~~

3

In order that none of the above steps in tactical development may be neglected, it is necessary: (1) that the tactical aspects of every situation that is confronted be known in detail, and (2) that strategically located personnel of rank and authority be assigned the specific responsibility of seeing to it that this information is acted upon promptly and effectively when necessary.

It is desirable that an army or air force be so organized that information necessary for tactical development be immediately available, that new tactics be rapidly and thoroughly worked out, and that the results be quickly disseminated. However, tactics is such an integral part of every activity in the AAF that the problem cuts across all conventional organizational barriers and constantly defies efforts to isolate the function and assign it to a single authority or organization. There are tactical aspects of training. There are training aspects to every tactic. There is a tactical factor present in every new development of materiel. There are nearly always some materiel problems presented by a newly conceived tactic. But perhaps the most difficult problem to cope with derives from the fact that tactical needs ultimately grow out of combat experience. And the men who are doing the fighting are likely to have little time to analyze that experience sufficiently to report its tactical elements and needs in order that experts at home may be enabled to devise new weapons and new uses for weapons old and new. A special difficulty faced by the U. S. Army Air Forces when the country found itself involved in the present war was

~~RESTRICTED~~
~~SECURITY INFORMATION~~

~~RESTRICTED~~
SECURITY INFORMATION

4

that of the limited number of experienced military personnel available for a large number of responsible positions at Headquarters, with combat units, in the training program, and in tactical development. These factors did not present themselves separately. They were part and parcel of every situation confronted by and within the AAF. And the situation was one which changed rapidly from day to day.

The picture of tactical development within the Army Air Forces during the period of wartime expansion, roughly from the summer of 1939 to the end of 1943, is consequently often confused as a result of frequent organizational changes and the deliberate postponement of any attempt at a comprehensive treatment of the problem of tactical development until fundamental difficulties of more immediate urgency were overcome.

Perhaps a word of explanation is due the reader in view of the fact that the development of the tactical air force is not treated in this study. The reason is that the creation of a tactical air force, a strategic air force, and the other components of the three air forces under the command of Air Chief Marshal Tedder in the Mediterranean, was fundamentally an organizational rather than a tactical achievement, as has been pointed out by Col. Percy M. Barr in a study on Lessons of Tunisia: Victory Through Organization, published in July 1943.¹ The basic concepts embodied in the new

1. AAFSAT Air Room Interview. See also Col. H. V. Dexter, G-3, 2d Armored Corps, Operation of Air Support for Ground Troops, AAFSAT Air Room Interview No. 1; Report on Organization of AAF in North Africa Prepared by Bradley Committee 23 June 1943; AAFSAT Intelligence Reports, Oct. 1943, "Fighter Support in North Africa"; "Air Power in the Final Phase of the Closing Campaign of the Battle for Tunisia, April 11 to May 14, 1943," study prepared by Combat Operations Branch, AFHQ.

~~RESTRICTED~~

5

~~SECURITY~~

employment of air power had been developed by airmen over a period of many years. The perfection of airplanes and armament and the tactics of air support of ground troops had finally made possible the translation of those concepts into a technique of employment for air power which has now become doctrine in the Army Air Forces.²

The development of the functional air command with its two principal offensive weapons, the strategical and the tactical air forces, involves tactics in their broadest aspect in that it permits of the freest and most efficient use of the newest military arm. Its initiation involved the heads of two Allied governments and their combined military staffs.³ Its application and test took place on the battlefield itself. Its adoption involved a major revision of military organization, thinking, and planning. Its origins cannot be specifically noted, for the doctrine which it embodies was the fruit of many years' thinking and experience to which many men and many factors contributed. But they are rooted in the painstaking and continuing work of tactical test and development, the function of which is to discover how men and materiel may be employed in warfare with maximum effectiveness.

-
2. WD Field Service Regulations, FM 100-20, "Command and Employment of Air Power," 21 July 1943.
 3. AAF Historical Studies: No. 6, The Ploesti Mission 1 August 1943.

~~RESTRICTED~~
~~SECURITY INFORMATION~~

Chapter I

THE ORGANIZATIONAL PROBLEM

Headquarters Organization of Tactical Development, 1939-1943

Shortly after the close of World War I, the Director of the Air Service sought permission to establish a tactical school.¹ In August 1920 the War Department authorized the establishment of a Field Officers' School at Langley Field, Hampton, Va.,² and in November 1922 the name of the school was changed to the Air Service Tactical School.³ In time, the crowded condition at Langley Field suggested the advisability of locating the Tactical School elsewhere, and in 1931 a board of officers decided upon Maxwell Field, in Alabama, as the most desirable alternative location.⁴ Here the school remained until the suspension of its activities in the spring of 1940.

At Maxwell Field, the Tactical School gradually developed the functions of a true tactical center. Not only were officers given tactical and technical training; an organization for research in

-
1. A letter from the Director of the Air Service to The Adjutant General, 21 October 1919, requested authority to establish an Air Service School of Application at Langley Field, Va., to develop and standardize the instruction and training of officers in the techniques and tactics of the Air Service. In AAF Central Files [hereinafter cited AAG] 352.9, Tactical School, Langley Field.
 2. WD GO # 18, 14 Aug. 1920.
 3. AR 350-105, 8 Nov. 1922.
 4. Memo for Executive by Training and Operations Div., 8 Apr. 1931, in AAG 352.9, Tactical School, Langley Field.

~~RESTRICTED~~
~~SECURITY INFORMATION~~

~~RESTRICTED~~
SECURITY INFORMATION

7

tactical employment of aircraft grew up and a demonstration air force was created. Projects were assigned to the center for solution. By 1939 the importance of the tactical center at Maxwell Field was sufficiently recognized so that it became the subject of a series of studies which were designed to establish its role, clarify the assignment of its responsibilities, and increase the efficiency of its operation and service to the Air Corps.⁵ And although the activities of the Tactical School at Maxwell Field were temporarily suspended in the spring of 1940, it was these studies and the thinking which went into them that provided the basis for the plans which were later drawn up and put into effect.

The increasing imminence of American involvement in war in Europe and in the East made necessary the rapid expansion of the military organization, an expansion which got effectively under way in the latter half of 1939. The war impressively demonstrated the tremendous role which the aerial arm would have to assume, and as a consequence the Air Corps found itself confronted with the necessity for putting into effect a tremendous training program. It had been foreseen that the Tactical School might have to be sacrificed temporarily in order to provide experienced personnel for training. Concurrent with the conduct of studies looking toward the improvement and expansion of the services of the tactical center, there were in progress others anticipating the temporary suspension of the activities of the Tactical

5. See: Col. W. R. Weaver, Comdt., Air Corps Tactical School, Maxwell Field, to Brig. Gen. B. K. Yount, Asst. C/AC, 19 Sep. 1939; R&R, Plans Div. to Executive, 11 Apr. 1940; Col. W. R. Weaver to C/AC, 17 Jan. 1940, and attached study, in AAG 321.9, Maxwell Field, Misc. Organizations.

~~RESTRICTED~~
SECURITY INFORMATION

~~RESTRICTED~~
~~SECURITY INFORMATION~~

8

School. These dealt with reorganization and the reallocation of personnel that would be imposed by the expansion program.⁶ It was this latter course which was followed perforce.

From the spring of 1940, when it was decided to suspend the activities of the Tactical School at Maxwell Field, to the early winter of 1942, when the new Army Air Forces School of Applied Tactics (AAFSAT) was established in Orlando, Fla.,⁷ responsibility for the development of tactics was scattered throughout the air force.⁸ Immediately prior to the creation of the Air Staff in June 1941, tactical development activities were coordinated at Headquarters by the Plans Division, Office of the Chief of the Air Corps. A Foreign Trends Unit of Section 2 (Intelligence) studied and made recommendations on "the application of foreign trends to Air Corps policy relating to equipment, tactics, techniques, organization and personnel."⁹ The Training, Tactics, and Air Strategy Unit of Section 3 (Operations) prepared "plans for the improvement of tactics and techniques." A Technical Committee Unit of Section 2 (Intelligence) established requirements and priorities and coordinated matters "pertaining to research, development and tests, including projects assigned to the Materiel Division, the Air Corps Board,

-
6. Col. G. H. Brett to C/AC, 11 Jan. 1939, in AAF 320, Misc., Orlando, Fla. See also directive of 1 November 1935 to President, Air Corps Board from Lt. Col. R. M. Jones, Acting Executive, OCAC, contemplating suspension of activity of the Air Corps Tactical School on M Day in accordance with the War Department Mobilization Plan, 1933, in AAG 321.9, Maxwell Field, Misc. Organizations.
 7. Organization Charts, 30 Apr. 1941 and 13 June 1942; AAF Reg. 20-1, 27 June 1941 and 31 Mar. 1942.
 8. Organization Chart, 30 Apr. 1941.
 9. Ibid.

~~RESTRICTED~~
~~SECURITY INFORMATION~~

ARMY AIR FORCES — AFTER REORGANIZATION of JUNE 20, 1941

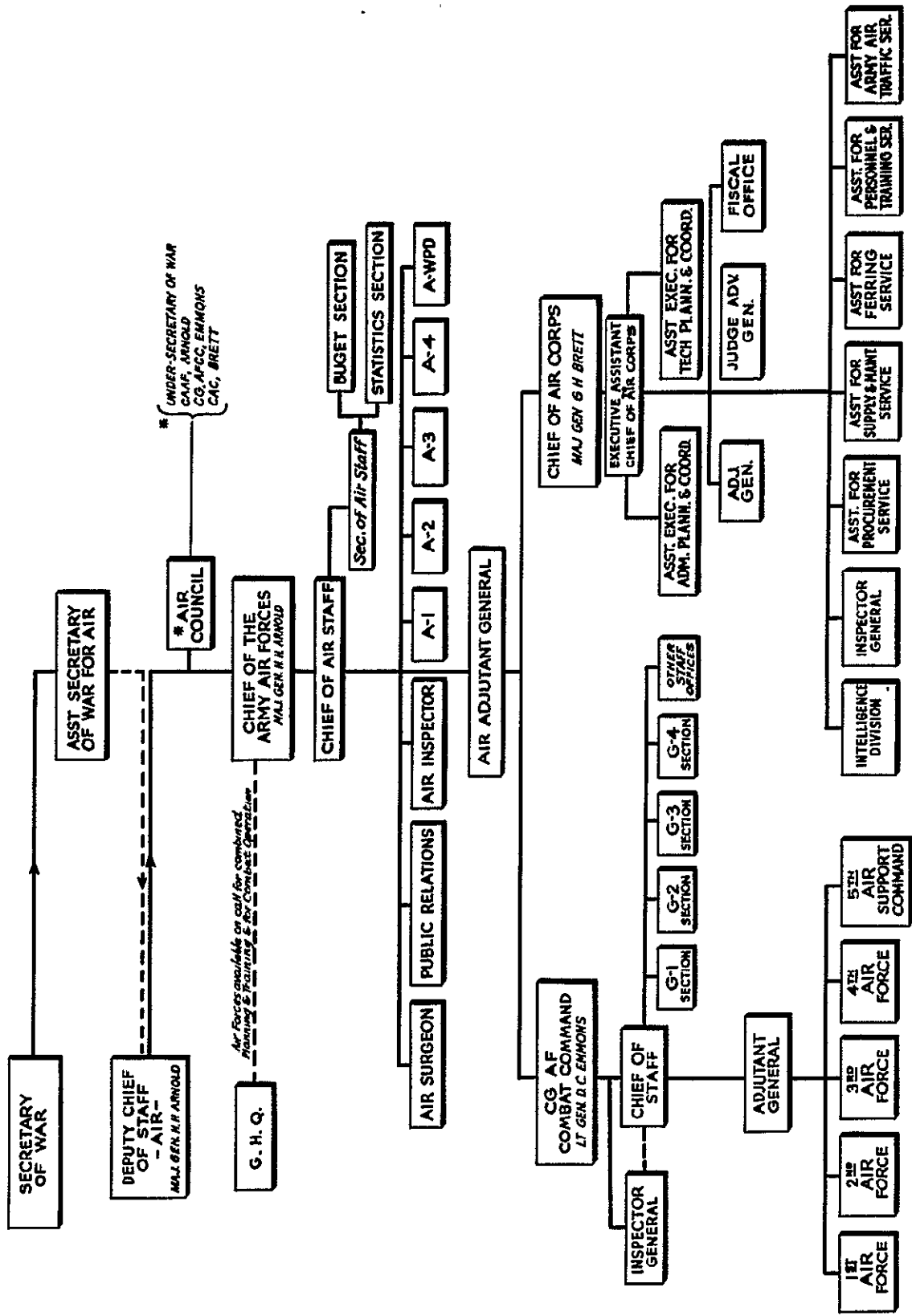

the 23d Composite Group, the Air Corps Proving Ground, and other organizations" which were actually engaged in the carrying out of tests under variously assigned projects. And under the Training and Operations Division, a Training Literature Unit coordinated "field and technical manuals between the Training Literature Unit, the Air Corps Tactical Schools, and other Air Corps agencies, and the War Department General Staff."¹⁰ When the Air Staff was created in June 1941, these functions were carried on by A-2, A-3, and the office of Air War Plans, and the coordination of tactical matters with the Air Force Combat Command was assumed. This, in broad outline, was the distribution of tactical development activities and responsibilities when the United States suddenly found itself at war with the Axis.

The reorganization of 9 March 1942 established the directorates.¹¹ The primary function of the directorates was to coordinate and direct the activities of the many offices and agencies which had been created in the course of expansion and to maintain liaison between Headquarters and the commands and other subordinate offices. In order to insure that the development of tactics would not be neglected, responsibility for fostering the development of tactics was assigned to every office within the directorates which exercised any supervision over agencies likely to confront tactical problems. The result was a considerable distribution of the functions of supervision, direction, and review

10. Ibid.

11. AAF Reg. 20-1, 31 Mar. 1942, and AR 95-5, 16 June 1942.

ARMY AIR FORCES ORGANIZATION

MARCH 9, 1942*

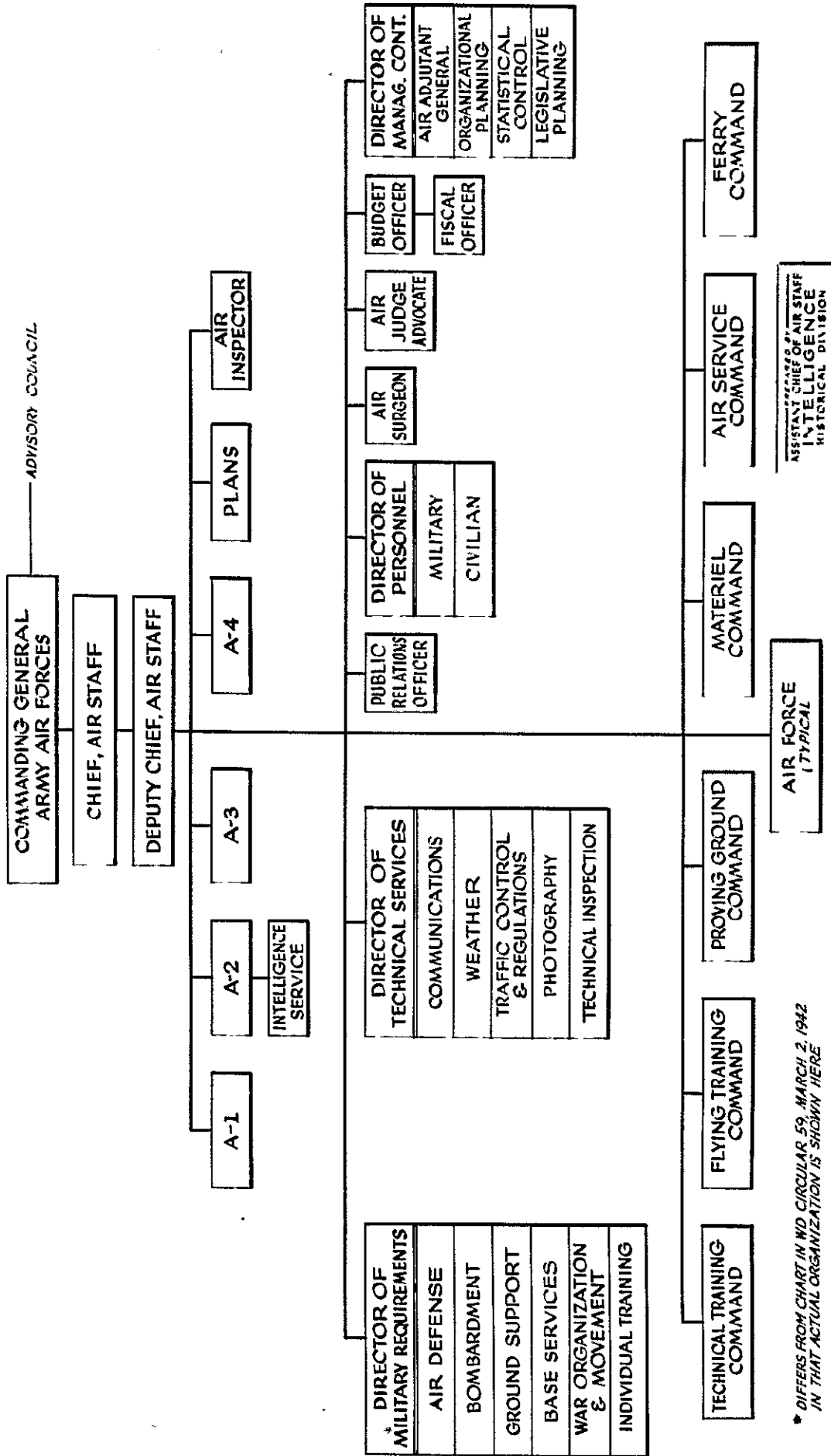

* DIFFERS FROM CHART IN WD CIRCULAR 59, MARCH 2, 1942 IN THAT ACTUAL ORGANIZATION IS SHOWN HERE

~~RESTRICTED~~
~~SECRET~~

under the sub-directorates which were subordinate to the Director of Military Requirements and the Director of Technical Services. Under Military Requirements were the directorates of Air Defense, Bombardment, Ground Support, Base Services, War Organization and Movement, and Individual Training. Under Technical Services were the directorates of Communications; Weather; Civil Aviation and Traffic Control; Photography, Maps and Charts; and Technical Inspection.

Under Air Defense a Development Section of the Fighter Division was assigned the task of coordinating "tactical units and Materiel Command relative to tactical requirements and technical possibilities." It organized experimental units and submitted them to service tests. It further developed tactics and techniques as determined by analysis of combat trends and tactics. A Current Operations Section of the Fighter Division coordinated tactical requirements with training programs and established training requirements as indicated by analyses of combat trends and tactics. The Plans and Projects Division recommended the institution of the latest developments in tactics and techniques of air defense. Under this division a Fighter Command School Liaison Section furnished constant liaison between the directorate and the Fighter Command School, which had been established in Orlando early in 1942.

The Directorate of Bombardment contained a Tactics and Technique Section to which was assigned responsibility for developing "tactics and techniques for Bombardment and accompanying aircraft operations to effectively perform the Bombardment mission." It also kept the directorate advised on matters regarding tactics and techniques in bombardment operations.

~~RESTRICTED~~
~~SECRET~~

~~RESTRICTED~~

11

The Directorate of Ground Support, or Air Support as it was sometimes called (meaning air support of ground operations), contained an Air Section under which an Observation Branch was made responsible for the development of tactics and techniques for ground-air support observation aviation while a Combat Branch performed a similar function with respect to combat aviation. Within the Ground Section of the directorate five branches--Infantry, Field Artillery, Cavalry, Armored Force, and Signal--were all assigned responsibility for the development of "tactics and techniques" appropriate to the service of the branch.¹²

The field organizations actively engaged in tactical test and development were chiefly the AAF Board, the Air Defense Board, the Fighter Command School, the AAF Proving Ground at Eglin Field, and the Materiel Command at Wright Field. However, reports of experience in the theaters of operations provided sufficient data to enable technical experts in the offices of the directorates to work out solutions to important tactical problems.¹³

The organization put into effect on 9 March 1942 was top-heavy. But like other reorganizations of the AAF, it was devised in response to the needs and possibilities of the moment. An immense air force organization had been built up almost overnight, and its personnel was lacking in military experience. It was essential that at this

12. Organization Chart, 13 June 1942.

13. See Chap. II

~~RESTRICTED~~

~~RESTRICTED~~
~~CONFIDENTIAL~~

point in the expansion of the AAF, experienced personnel be concentrated at the top and placed in a position to give detailed supervision and direction to the myriad activities of the new organization. This placed a heavy burden upon the directorates and inevitably resulted in duplication of responsibilities for review; it as inevitably tended to retard action and to delay the reaching of decisions affecting activities throughout the air force. But serious as were these dangers, which are inherent in any top-heavy organization, the alternative was even more dangerous. Unless all AAF activities were subject to direction and review by experienced men, strategically located at the top, there would have been left open the possibility that vital services might have been neglected by personnel whose limited experience would not have enabled them to discern the neglect and correct it promptly. Ideally, most of the directive and review functions exercised by the directorates should have been decentralized--allocated to lower echelons--just as soon as procedures became clarified and the new personnel became sufficiently familiar with broad problems to be capable of assuming wider responsibilities. But for a time the tendency was just the reverse.

Nearly 11 months after the directorates had been instituted, a new organization chart was issued revealing the extent to which their organizational units had been multiplied and their directive functions extended.¹⁴ It is worth while to note the variety of relationships established between the Headquarters directorates and the newly created AAF School of Applied Tactics at which tactical development was now to

14. Organization Chart, 25 Jan. 1943.

ORGANIZATION OF THE ARMY AIR FORCES

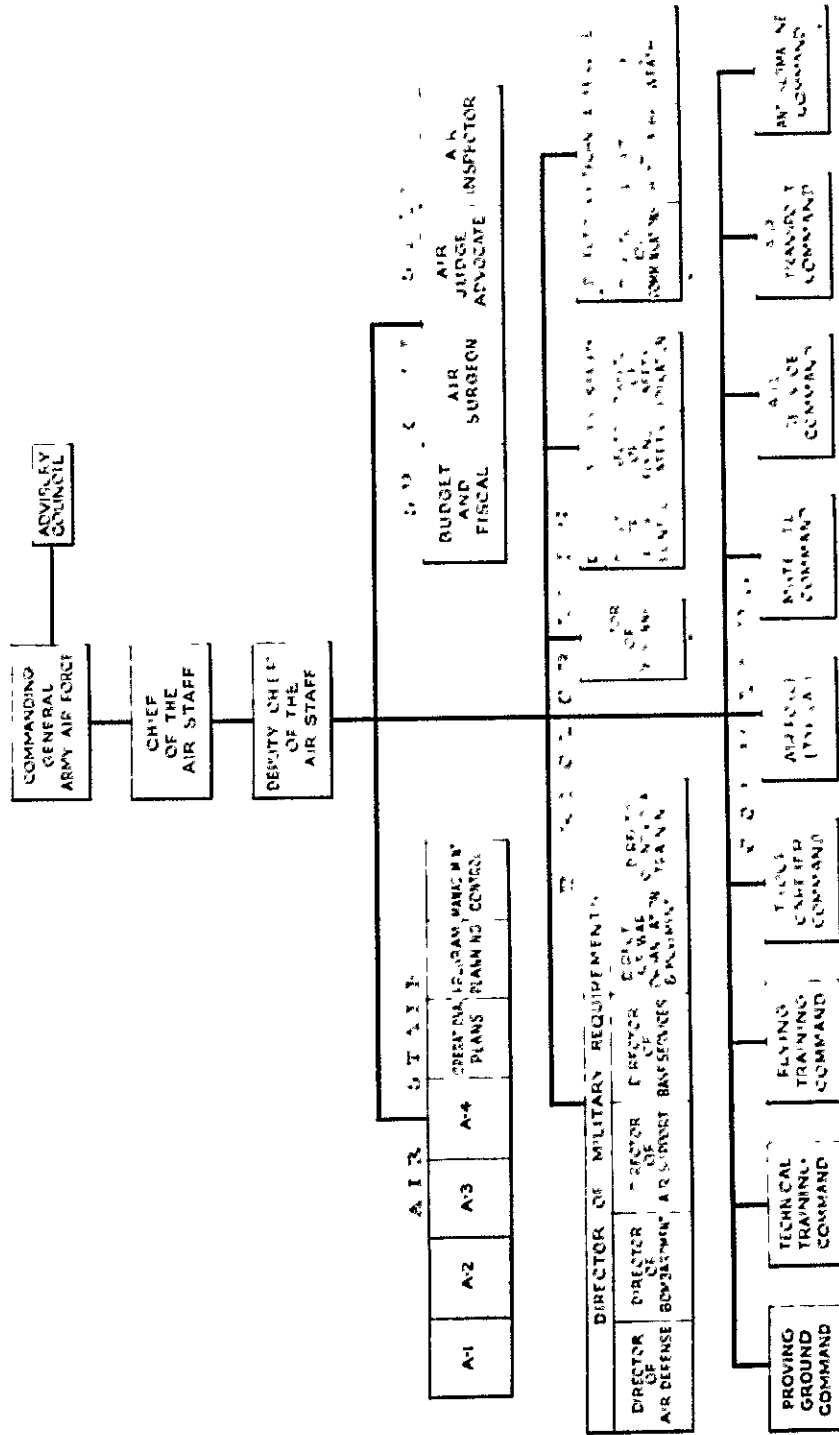

JANUARY 25, 1943

~~RESTRICTED~~

13

~~SECURITY INFORMATION~~

be centered. These elaborate and complicated relationships, involving dispersed and pyramiding responsibilities of supervision and review, not only inhibited the development of AAFSAT and the AAF Board, but they tended to involve the business of tactical development in time-consuming procedures which, if not checked, would nullify much of the work of the tactical center.

Under the January reorganization, the Director of Military Requirements exercised for the Commanding General, AAF, "control of the AAF School of Applied Tactics."¹⁵ But under this directorate four "type directorates" were assigned control of the activities of the tactical center. The Director of Air Defense, part of whose mission was "to determine the tactics for unified air defense operations," made frequent field trips to observe functions of and ascertain military requirements for fighter aviation, aircraft warning service, and airdrome defense.¹⁶ He also maintained "direct liaison with the Air Defense Department of the AAF School of Applied Tactics on all matters relating to tactics and techniques of air defense training; [and] maintain[ed] liaison through the Director of War Organization and Movement with the Commandant of the School with respect to the operation of the Air Defense Department."¹⁷

Under the Director of Air Defense a Field Inspection Section made detailed surveys of the fighter commands in the United States and over-

15. Ibid., Directorate of Military Requirements, Item 9.

16. Ibid., Directorate of Air Defense, Item 6.

17. Ibid., Item 8.

~~RESTRICTED~~~~SECURITY INFORMATION~~

~~RESTRICTED~~

14

seas. This function was also performed intermittently by the Air Defense Board, the personnel of which was drawn from the Directorate of Air Defense and from AAFSAT. An Assistant Director, Plans and Projects, defined and submitted projects to the Air Defense Department of the AAFSAT Board¹⁸ and maintained liaison with the board, seeing that action was taken on reports received from it. An Operational Analyst analyzed existing and planned operational methods for air defense and made recommendations for increasing their efficiency. An Aircraft Warning Division, through its Plans and Development Section, developed tactics and techniques for aircraft warning service operations, determined military characteristics and operational requirements for new aircraft warning equipment, promulgated operational procedures for the use of all aircraft warning installations, conducted inspections to insure the observance of proper procedures, and made recommendations regarding aircraft warning service for the theaters of operations to the Operations Division, General Staff. A Division of Anti-Aircraft and Airdrome Defense had an Airdrome Defense Section which made recommendations on tactical doctrine employed in airdrome defense. A Fighter Division had a Communications Section and a Training and Tactics Section both of which collaborated with AAFSAT in the performance of their functions.

18. Designated elsewhere as the Air Defense Department Board of AAFSAT. This was the Air Defense Board which was set up in November 1942 and predated AAFSAT.

~~RESTRICTED~~

~~RESTRICTED~~

15

The Directorate of Bombardment was more simply organized with respect to its responsibilities for tactical development. Its mission was "to direct the development of heavy and medium bombardment aviation; to determine the tactics, and the technical requirements of personnel and equipment; and to establish training standards for personnel and units of heavy and medium bombardment aviation." Two divisions were concerned with tactical development and application, the Status and Operations Division and the Training Division. The Status and Operations Division made frequent inspections of the status of operations of bombardment units in the theaters of operations and on the basis of these observations prepared formal reports and submitted recommendations to higher authority where corrective action seemed necessary. The Training Division maintained direct liaison with the Bombardment Department at AAFSAT on all matters relating to tactics and techniques of heavy and medium bombardment aviation and prescribed training standards for use in the Bombardment Department of AAFSAT. It also integrated the development and distribution of heavy and medium bombardment training aids through liaison and cooperation with the Air Service Command, the Materiel Command, and AAFSAT.

The general mission of the Director of Air Support with respect to tactical development was similar to that of the other sub-directorates of Military Requirements. A Liaison and Intelligence Division collected, collated, catalogued, and distributed to other divisions of the directorate and, after proper coordination, to other activities of the AAF, information and intelligence relating to air support

~~RESTRICTED~~
~~SECRET~~

aviation. A Communications Division planned and developed tactics and techniques and disseminated tactical and technical doctrine pertaining to air support communications units. It also planned and developed techniques of air support signal operations and disseminated to field activities technical doctrine pertaining to air support and signal operations through the preparation of field manuals, technical manuals, publications, and correspondence. A Combat Division, an Observation Division, and a Transport and Facilities Division were all assigned similar responsibilities with respect to tactical development, to plan and develop tactics and techniques and disseminate tactical and technical doctrine which fell within the fields of their assigned responsibilities.

The tactical mission of the Directorate of War Organization and Movement was "to provide liaison between both Headquarters AAF offices and other War Department offices, and the Proving Ground Command, the School of Applied Tactics, the Headquarters Army Air Base, Bolling Field, the Cold Weather Testing Detachment, Sherman Field, and the Civil Air Patrol," most of the liaison work being handled by a Special Projects Division.

Under the Director of Technical Services, a Directorate of Photography was responsible for developing the most effective use of aerial photographic mapping and charting and for devising tactics and techniques and training doctrine required for aerial mapping and charting. A Directorate of Weather developed effective weather service for the Army and determined training doctrine. It also devised and improved weather equipment, technique, and tactics.

~~RESTRICTED~~
~~SECURITY INFORMATION~~

17

In summary, more than 25 organizational units at Headquarters were in some degree responsible for originating, fostering, directing, supervising, controlling, inspecting, and reviewing tactical development and were further made responsible for establishing tactical standards and disseminating tactical information to the air forces. Had this process of extension of directive powers been permitted to continue, it would have defeated the purpose which the newly created AAF tactical center and Air Forces Board were designed to serve. As it was, the dispersal of tactical functions which took place under the directorates undoubtedly retarded, to an extent, the full assumption of responsibilities by these new tactical agencies.

The tendency toward the elaboration of directive functions and the complication of Headquarters procedures which had gathered momentum during the course of 11 months were reversed in the AAF reorganization of 29 March 1943.¹⁹ The directorates were disbanded and their function and responsibilities were divided between the commands and the staff. The removal of the mediatory directorates brought the staff into closer relationship with the commands and to that extent made possible an acceleration of the translation of policy and doctrine into practice. A number of services which could be performed better by offices in Headquarters than by lower echelon organizations were assigned to the Assistant Chief of Air Staff, Operations, Commitments, and Requirements (OC&R), an office created

19. Organization Chart, "U. S. Army Air Forces, Organization and Functions," 29 Mar. 1943.

~~RESTRICTED~~
~~SECURITY INFORMATION~~

ARMY AIR FORCES ORGANIZATION

MARCH 29, 1943

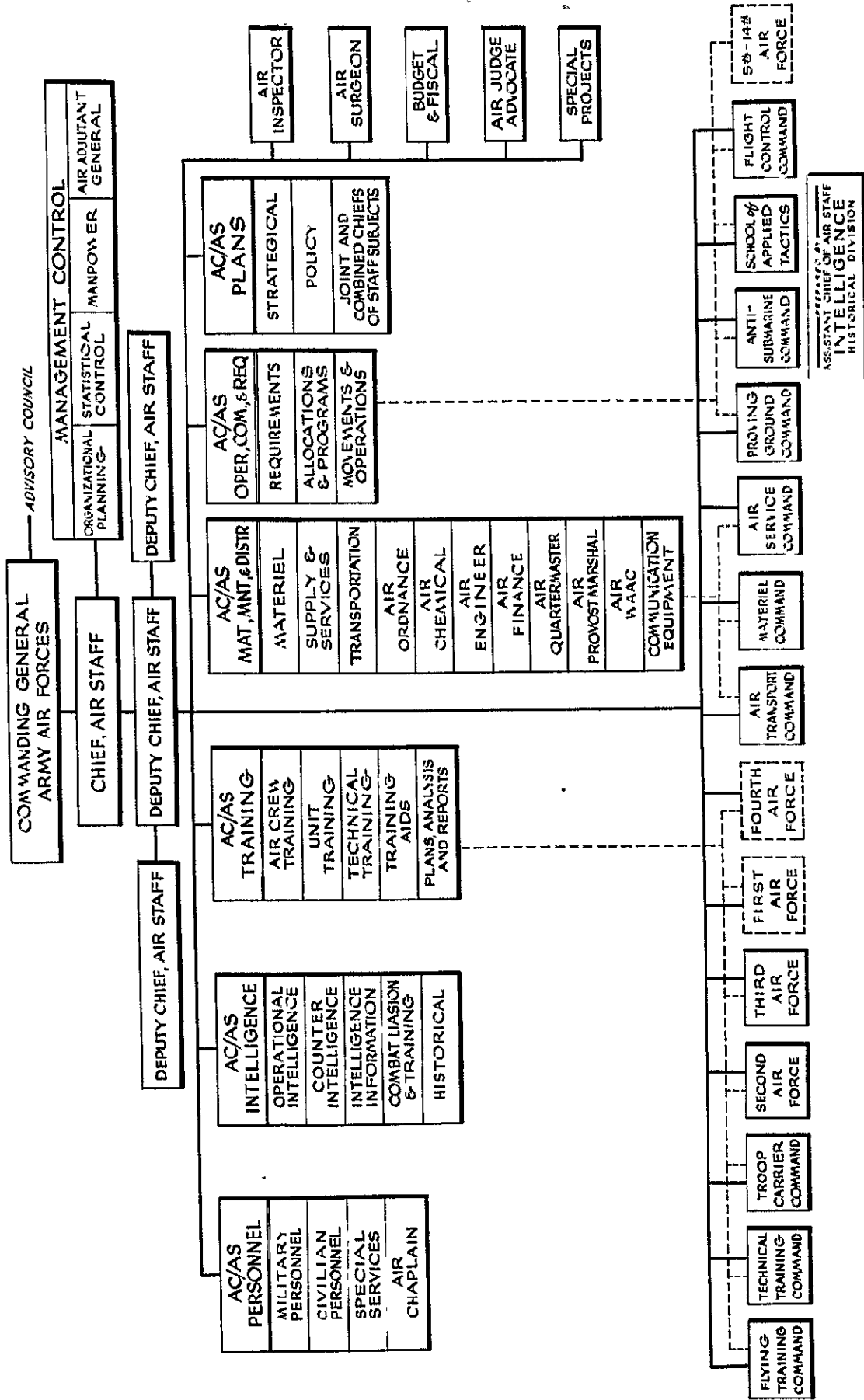

~~RESTRICTED~~

18

~~SECURITY INFORMATION~~

under the new AAF reorganization. One of the functions assigned to this office was that of determining tactics and techniques of aerial warfare for the Army Air Forces.

With specific reference to development of tactics, the organizational chart of 29 March 1943 declared that OC&R:

Determines tactics and techniques of aerial warfare and establishes technical and tactical proficiency requirements for air force combat and attached service units, transmitting such requirements to Assistant Chief of Air Staff, Training, and to air forces

Maintains observers in theaters of operations and defense commands to determine means of increasing the combat effectiveness of Army Air Forces Units, through improvement of personnel, materiel, organization, training, and tactical doctrine.

Provides overall supervision of the activities of the Army Air Forces School of Applied Tactics, the Proving Ground Command, and the Cold Weather Testing Detachment.²⁰

Indirectly related to and affecting the problem of tactical development were other controls assigned to OC&R. The office was to determine and approve military characteristics for all materiel procured or used solely by the Army Air Forces. It was to direct the preparation of, approve, and process for the AAF all Tables of Organization, Tables of Allotment, Manning Tables, Tables of Basic Allowances and Equipment Lists. Further, it was to allocate and order the movement of aircraft and aircrews to meet the AAF strategical, tactical, and technical requirements.²¹ Within OC&R responsibility for the direction of tactical development fell to the Requirements Division initially.

20. Ibid., Summary Statement of Functions, 8.

21. Ibid., 8-A.

~~RESTRICTED~~~~SECURITY INFORMATION~~

~~RESTRICTED~~
~~SECURITY INFORMATION~~

The Chief of the Requirements Division had an Assistant for Tactics and Plans who supervised the operations of the several branches insofar as they concerned tactics and plans. Air Defense, Bombardment, and Air Support branches were delegated responsibilities prescribed for the Requirements Division which fell within their respective spheres. A Tactical Services Branch dealt with matters relating to weather, photography, and communications; on 8 May 1943 this branch was transferred to the Movements and Operations Division of OC&R and became part of a new Technical Services Division. A Requirements Liaison Branch performed the familiar functions of liaison for the Requirements Division.²²

The actual test and development of tactics took place at the tactical center in Orlando. But the ultimate source of any tactical problem, as well as the final test of any tactic, is combat. The tactical need always develops out of combat operations, whether these occur in a theater of operations in actual warfare or in the military exercises and tests which substitute for that condition in time of peace. It is necessary therefore that the tactical center, seeking solutions upon which depend the lives of men and the issues which they represent, be fully cognizant of the conditions and circumstances of actual warfare out of which the problem arises. Obviously, the newly created tactical center was not in a position to obtain for itself all the information that would be needed to define and solve tactical problems arising in many theaters of

22. Ibid.

~~RESTRICTED~~
~~SECURITY INFORMATION~~

~~RESTRICTED~~
~~SECURITY INFORMATION~~

operations scattered over the face of the globe, in which every possible combination of conditions was confronted. As obviously, AAF Headquarters in Washington was the agency through which this information could best be assembled, sifted, and considered. This function was assigned to OC&R.

But often a combat situation involving tactical aspects is not completely soluble in terms of tactics alone. The difficulty may be met in part by an increase in the speed or maneuverability of a plane or by an increase in quantity or change in the caliber of a plane's armament. Such a situation involves questions of materiel and equipment as well as tactics. Again, all these factors could best be weighed and dealt with at Headquarters where the component parts of the initial problem could be assigned as projects, with the necessary degree of priority, to the appropriate developmental agency. Thus OC&R was assigned responsibility for defining and assigning projects to the tactical center.

In order to carry on its work, it was necessary that the tactical center be provided with adequate personnel and equipment. Here again, through its control over allocations of AAF units and equipment, OC&R found itself in a position to facilitate the work of the tactical center by making sure that the evolution of vitally important tactics was not retarded through failure to provide properly experienced test units and special personnel and equipment.

Finally, it was necessary that the tactics developed at Orlando be reviewed in the light of the latest combat experience and that the

~~RESTRICTED~~
~~SECURITY INFORMATION~~

~~RESTRICTED~~

recommendations of the tactical center be placed in the hands of the men flying planes in the theaters of operations in a manner which would insure their prompt employment against the enemy. Related, as part of the general function of dissemination of tactical information, was the responsibility for seeing to it that changes which altered fundamental tactical doctrine be embodied in training and incorporated in changed training standards when necessary. OC&R was charged with this function.

In summary, the very important service performed by OC&R in tactical development presented the following four aspects:

1. Discerning the need for a tactical solution to a particular combat situation.
2. Defining the problem and assigning it as a project, or projects, to the appropriate developmental unit, or units.
3. Obtaining and placing all necessary information in the hands of the organization charged with the project and providing the developmental center with special personnel and equipment needed to complete the projects assigned to it.
4. Disseminating the findings of the tactical center to the combat theaters and other AAF elements affected.

OC&R was charged with a further responsibility which cannot be classified properly as part of a service activity, since it is strictly a Headquarters prerogative of supervision and direction. This was that it provide over-all supervision of the activities of the AAF School of Applied Tactics, of which the tactical center was a part.²³

23. Ibid.

~~RESTRICTED~~

~~RESTRICTED~~

22

The School of Applied Tactics and the Army Air Forces Board

In order to isolate the problem of tactical development and to determine to what extent the function could be decentralized, it was necessary that there be created a center for the conduct of tactical development and testing and one at which tactical instruction could be given to flyers about to be dispatched to the theaters of operations. To this end there was established at Orlando, Fla., in November 1942 the Army Air Forces School of Applied Tactics (AAFSAT). The new organization was composed of available units which had been engaged in some degree in conducting test and development under the direction of Headquarters, Washington. Inevitably, the rapidity with which the new tactical center could assume and perform the functions assigned to it was determined by the nature of the organizations which became its components, and by the nature of the facilities made immediately available to it. An examination of these factors is essential to an understanding of the situation which existed during the first months of AAFSAT's operation.

During the early months of 1943, while the directorates, by a kind of fission, were multiplying organizational cells and were extending and specifying directive and review functions, the tactical center at Orlando was rapidly preparing itself to assume broader responsibilities in the development of tactics. The origins of the AAF School of Applied Tactics, which was redesignated the AAF Tactical Center (AAFTAC) in October 1943, help explain this preparation for greater service.

~~RESTRICTED~~
~~SECURITY INFORMATION~~

23

In the spring of 1940 the activities of the old tactical center at Maxwell Field were suspended because of the imperative need that its experienced personnel be employed in Headquarters, in the training program, and in the tactical units of the rapidly expanding air forces. It was pretty generally recognized that the suspension of the activities of the tactical center was only temporary, and in the minds of many responsible officers practical means for its re-establishment were being considered. At Maxwell Field, the librarian of the old tactical school kept the collection intact and continued to accession material in order to keep it up-to-date. When, in July 1942, Col. Harvey H. Holland was called to succeed Lt. Col. J.G. Hopkins as head of the Training Literature Division under the Director of Individual Training in Washington, he laid claim to the library of the Tactical School at Maxwell Field. A Personnel Procurement Section was established under Colonel Holland, the chief purpose of which was to recruit and commission civilians whose background would enable them to prepare training manuals and other teaching aids for the Training Literature Division. Colonel Holland anticipated that this organization would be absorbed eventually into a new tactical school, part of the function of which would be to establish and maintain tactical training standards, and to disseminate information with that end in view.²⁴

24. Interview with Capt. Charles C. Robinson, AC, Special Projects Officer, AAFSAE, 6 Nov. 1943, AFTHI files.

~~RESTRICTED~~

~~RESTRICTED~~

24

Throughout the spring and summer of 1942 there was much discussion, both written and oral, of the need for re-establishing a tactical center. Naturally, most of that which took place in conversation is lost from the record. In a memorandum to Maj. Gen. G. E. Stratemyer, Chief of the Air Staff, Col. Don Zimmerman, Director of Weather, recommended that a tactical school be established at the earliest possible date. He observed:

The Army Air Forces in closing its tactical school and reducing the Air Force instructors at the Command and General Staff School have followed a policy contrary to the other branches of the Army. It is realized that the unusual requirements for experienced officer personnel in the Headquarters of the Army Air Forces and in the tactical units has caused the withdrawal of officers from both the above activities but it is believed that such a policy is only a temporary expedient and will prove to be shortsighted in the long run.

Among those engaged in working out a plan for a new tactical center during the course of the summer of 1942 were: General Stratemyer; Col. Edgar P. Sorensen, AC/AS, Intelligence; Maj. Gen. Muir S. Fairchild, Director of Military Requirements; Col. Hume Peabody, Director of War Organization and Movement; and Col. Gordon P. Saville, Director of Air Defense. On 1 September 1942 Colonel Holland and Col. Luther S. Smith, Director of Individual Training, submitted memos to General Stratemyer outlining plans for a tactical school.

-
25. Memo for Maj. Gen. G. E. Stratemyer, Chief of the Air Staff, (unsigned), 27 June 1942, in AAG 352, School of Applied Tactics.
26. Copies in AFHFI files.

~~RESTRICTED~~

~~RESTRICTED~~
~~SECURITY INFORMATION~~

25

A number of the plans proposed envisaged the creation of four tactical schools in different localities, one each for Air Defense, Bombardment, Air Support, and Air Service. An investigation of available sites was undertaken. It was decided finally to locate all four tactical training projects in a single school at Orlando, where ample space was available. This centering of tactical training and development under a single administration would save administrative costs and physical outlay, and would facilitate close coordination among the four departments and agencies responsible for tactical development.

The Orlando site was decided upon around 1 November 1942, and on 12 November 1942 the Army Air Forces School of Applied Tactics was activated.²⁷ Two of the departments of AAFSAT were set up as going concerns from the start, the Air Defense Department and the Air Service Department, as there were already in existence organizations which could be assimilated to form these departments of the school. The most completely developed of these organizations was the Fighter Command School which became the Air Defense Department of AAFSAT. In February 1942 the Fifth Interceptor Command under Col. W. R. Taylor, was dispatched to Orlando from San Francisco to form the Interceptor Command

27. AAF Reg. 20-14, 12 Nov. 1942.

~~RESTRICTED~~
~~SECURITY INFORMATION~~

~~RESTRICTED~~

School.²⁸ Shortly thereafter, all interceptor units in the AAF became known as fighter units and the school was henceforth known as the Fighter Command School.²⁹ At the time the Fighter Command School became the Air Defense Department of AAFSAT under Taylor (by then a brigadier general), Assistant Commandant, it had developed radar and radio instructional facilities and, in addition to the personnel of the Fighter Command School, had the 50th Fighter Group as an operational training unit, the only place in the United States where fighter-searchlight tactics were being taught.

The Air Service Department was also a going concern from the start. The old 91st Service Group at Camp Dix, N. J., was transferred to Orlando and became the Air Service Department of AAFSAT under Col. John M. McCulloch, who became Assistant Commandant. However, it had still to develop a teaching organization.³⁰

28. Late in 1941, the Second Interceptor Command at Seattle, Wash., was stripped of its personnel in order to enlarge the Fifth Interceptor Command located in the Hawaiian Islands. These reinforcements were designated Fifth Interceptor Command and were moved to San Francisco, from which port they put out for Manila on 6 December 1941. The command was at sea when the Japanese attacked Pearl Harbor. The ship was ordered back to port to await convoy. In view of the danger of attack upon the West Coast, the reinforcement units, still designated the Fifth Interceptor Command, were returned to Seattle to take up their old work with the Second Interceptor Command in defense of the coast. Apparently the command was returned to San Francisco before being ordered to Orlando early in February 1942. See Interview with Capt. C. C. Robinson, and Historical Data, 481st Night Fighter Operational Training Gp., AAFZAC.

29. Interview with Capt. Charles C. Robinson.

30. Ibid. The facts referred to were checked with documents in the files at Orlando before this interview was signed by Captain Robinson.

~~RESTRICTED~~

~~RESTRICTED~~

27

~~SECURITY INFORMATION~~

Col. H. G. Montgomery, Jr., Chief of the Tactics Section of the Directorate of Bombardment at Headquarters in Washington was sent to Orlando to take charge of the Bombardment Department as Assistant Commandant. The 9th Bombardment Group was subsequently assigned to AAFSAT as a training unit. An Air Support Department was designated under the command of Col. M. H. McKinnon as Assistant Commandant.³¹

The most immediate need which was to be met by the new organization at Orlando was that of cadre training in tactics. Classroom instruction and demonstration under simulated combat conditions were both important elements in that training. During the winter months of 1942 and 1943, AAFSAT rapidly developed curricula, instructional staffs, demonstration units, and bases from which to conduct operations. However, the new organization immediately faced the need of continuing tactical projects which were in the course of development under units being absorbed by AAFSAT. Some of these were under the direction of the Air Defense Board which came into being in the spring of 1942 shortly after the establishment of the Interceptor Command School.

It had not been anticipated that the new school could begin operations before January 1943.³² On the twenty-third of that month

31. Ibid.

32. Col. M. H. McKinnon, Air Support Dept., AAFSAT, to CG, Troop Carrier Command (thru Dir. of Air Support), 12 Nov. 1943, in AAG 352, School of Applied Tactics. At this time the Fighter Command School was absorbed into AAFSAT in accordance with directive. In a memo for the Director of Military Requirements, 18 February 1943, the Director of Air Defense reported that from May 1942 to January 1943 an average of 518 officers and 579 enlisted men had been trained monthly by the Fighter Command School "for a total of 92,000 average hours of instruction per month." In ibid.

~~RESTRICTED~~

~~RESTRICTED~~
~~SECURITY INFORMATION~~

28

a Headquarters Office Instruction announced that departmental boards had been set up in the four departments of AAFSAT to perform the necessary research, development, and test of techniques, organization, and equipment as required by: (1) directives from the AAF Board, (2) the receipt of instructions and/or equipment forwarded by the type director concerned in Headquarters, AAF, (3) the definite need found to exist by the department of the school concerned, and (4) requests from other governmental agencies when approved by the Commanding General, AAF.³³

It has already been pointed out that tests ultimately involving tactical problems were concurrently conducted by the Materiel Center at Wright Field and by the Proving Ground Command at Eglin Field. On 20 February, Brig. Gen. E. L. Eubank, Director of Bombardment, stated the relationship of these three organizations to the Director of Military Requirements:

New equipment and weapons are developed and procured by the Materiel Command under the direction of this headquarters. Eglin Field then conducts special service tests which form the basis of determining the operational suitability and the necessary refining modifications thereto. If suitable, the weapon or equipment is then turned over to AAFSAT for development and publication of proper methods of employment.³⁴

The re-establishment of a tactical center--a project long held in abeyance through necessity--is symptomatic of the change which

33. AAFTAC Hq. O. I., 23 Jan. 1943.

34. In AAG 352, School of Applied Tactics.

~~RESTRICTED~~
~~SECURITY INFORMATION~~

had taken place throughout the Army Air Forces. Personnel had gained in experience and capacity for assuming and exercising responsibilities capably. Experience had likewise clarified many functions, and the passage of time in combination with these other factors had made possible the improvement of organization on lower echelons. A reorganization of the AAF in line with the new possibilities that had been opened up by time and experience was in order and was being thought out. Reassured that no important change in the plan for the tactical center was being contemplated,³⁵ on 15 March 1943, Brig. Gen. Hume Peabody, the Commandant, approved an organizational chart which was forwarded to Headquarters, Washington.³⁶ While the chart was in some respects no more than a plan on paper, it did represent the organization which was in rapid process of formation.³⁷

When the new tactical center was established in November 1942 there were a number of developments then in progress under the direction of the Air Defense Board. Although the old Air Corps Board, which had been located at Eglin Field, was dissolved shortly before the March 1943 reorganization of the AAF, the Air Defense Board continued to carry on its work at Orlando without interruption to November 1942. The same AAF Regulation which established the School of

35. Memo for Comdt., AAFSAT (thru C/AS) by Management Control, 13 Mar. 1943, in AAG 321, Organization.

36. Organization Chart drawn up at AAFSAT and signed by Brig. Gen. Hume Peabody on 15 Mar. 1943, in AAG 352, School of Applied Tactics.

37. Interview with Capt. Charles C. Robinson.

ORGANIZATIONAL CHART — ARMY AIR FORCES SCHOOL OF APPLIED TACTICS

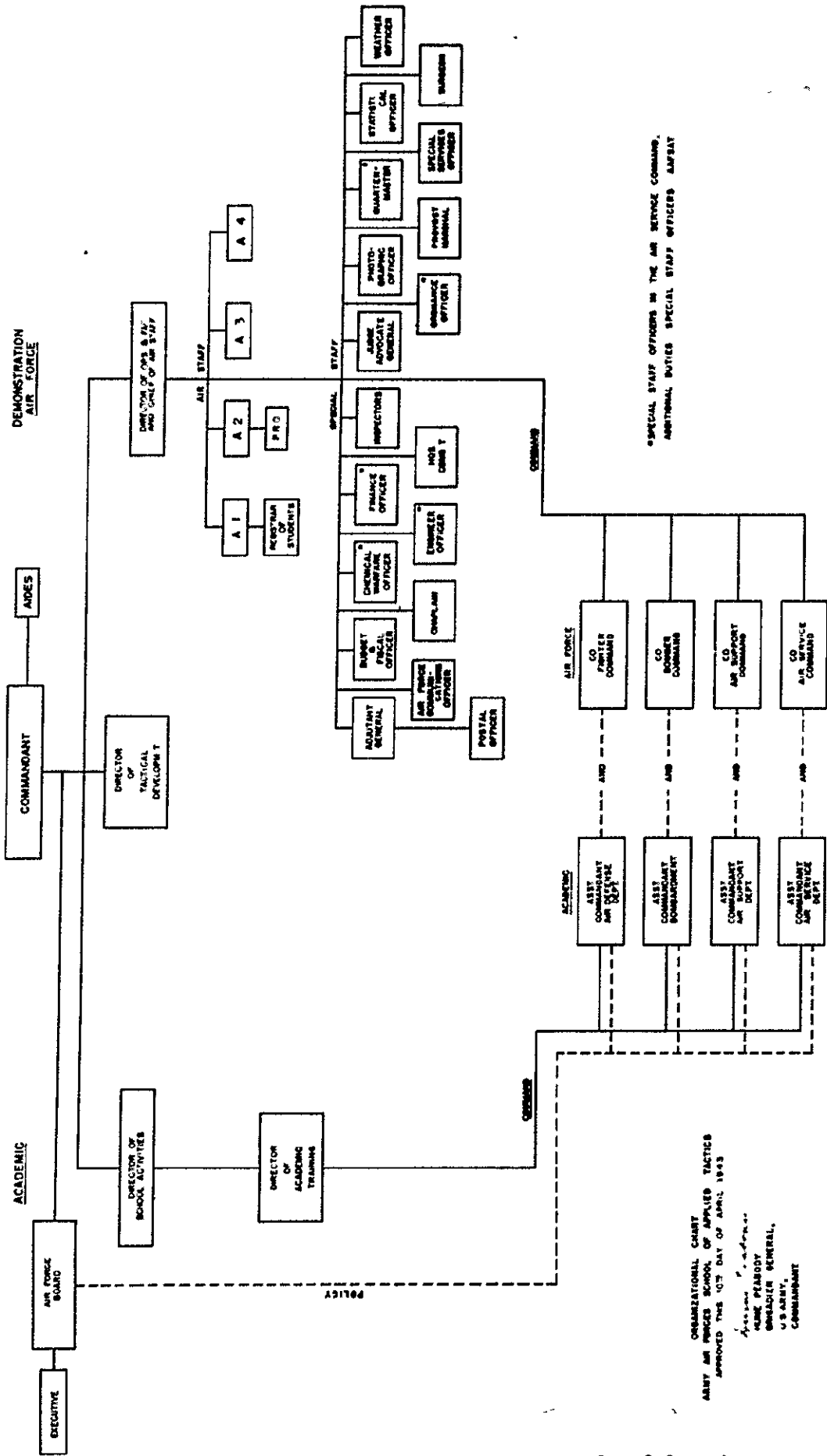

SPECIAL STAFF OFFICERS IN THE AIR SERVICE COMMAND.
 ADDITIONAL DUTIES SPECIAL STAFF OFFICERS AIRFAT

ORGANIZATIONAL CHART
 ARMY AIR FORCES SCHOOL OF APPLIED TACTICS
 APPROVED THIS 10TH DAY OF APRIL 1943

James P. ...
 CHIEF HEADQUARTERS
 GENERAL
 U.S. ARMY
 COMMANDANT

Incl. #1 to G.O. #53, AAFSAT, 4-17-43.

~~RESTRICTED~~

Applied Tactics also proclaimed the existence of the Army Air Forces Board,³⁸ which immediately took over general supervision of developmental projects while the Air Defense Board became part of the Air Defense Department and a subordinate agency of the AAF Board.

This first AAF Board consisted of a president and a recorder. Its first function was the assignment of tactical projects to the appropriate developmental units at Orlando. However, it was assumed from the start that the functions and responsibilities of the board would be greatly expanded as the opportunity arose. A pattern for an AAF Board with extensive powers was provided by the Infantry Board, and already AAF Headquarters planners were considering a reorganization of the AAF and the centralization of many Headquarters functions. It was obvious, of course, that circumstances would have to determine just how much responsibility and authority could be assigned to the new board at any particular time. Consequently, during the first six months of 1943, the responsibilities assumed by the AAF Board were, of necessity, tentative and exploratory.

On 6 April 1943 there was established the Army Air Forces Equipment Board to function as a subagency of the AAF Board, to make recommendations regarding the adoption and issue of AAF equipment, and to review constantly the suitability of current equipment with a view of eliminating unnecessary or unsuitable items. And on 17 April 1943 General Peabody submitted to Headquarters an organizational chart which subordinated

38. AAF Reg. 20-14, 12 Nov. 1942.

~~RESTRICTED~~
~~SECURITY INFORMATION~~

31

the AAF Board to the Commandant of the School of Applied Tactics. Accompanying the chart was a general order designating Brig. Gen. Gordon P. Saville both Director of Tactical Development at AAFSAT and member of the AAF Board.³⁹ Largely through the energy of General Saville, the board developed its services to the point where it became possible to make an official assignment of responsibilities.

It was not until 2 July 1943, however, that an AAF Regulation authorized the establishment of the AAF Board--which had heretofore enjoyed a kind of legal existence by implication--and assigned to it specific functions.⁴⁰ It was declared that the board had no operating responsibilities but was to be responsible for:

- a. Coordinating the activities of the Office of the Director of Tactical Development, the Proving Ground Command, and the AAF School of Applied Tactics to insure the most efficient utilization of personnel and facilities to accomplish their combined missions.
- b. Reviewing, approving, or providing for the approval of all matters pertaining to the development, operational testing and the establishment of military requirements for all tactical aircraft, equipment, organizations, and doctrine.

The board continued subordinate to the authority of the Commandant of the School of Applied Tactics.

In order to understand the position of the AAF Board it is necessary to examine the concept of it which was developed during the first half of 1943. Over a period of months General Saville

39. AAF Reg. 20-16, 6 Apr. 1943; AAF GO # 53, 17 Apr. 1943.

40. AAF Reg. 20-20, 2 July 1943.

**ORGANIZATION CHART
FOR
EXECUTIVE DIRECTOR OF
ARMY AIR FORCES BOARD.....**

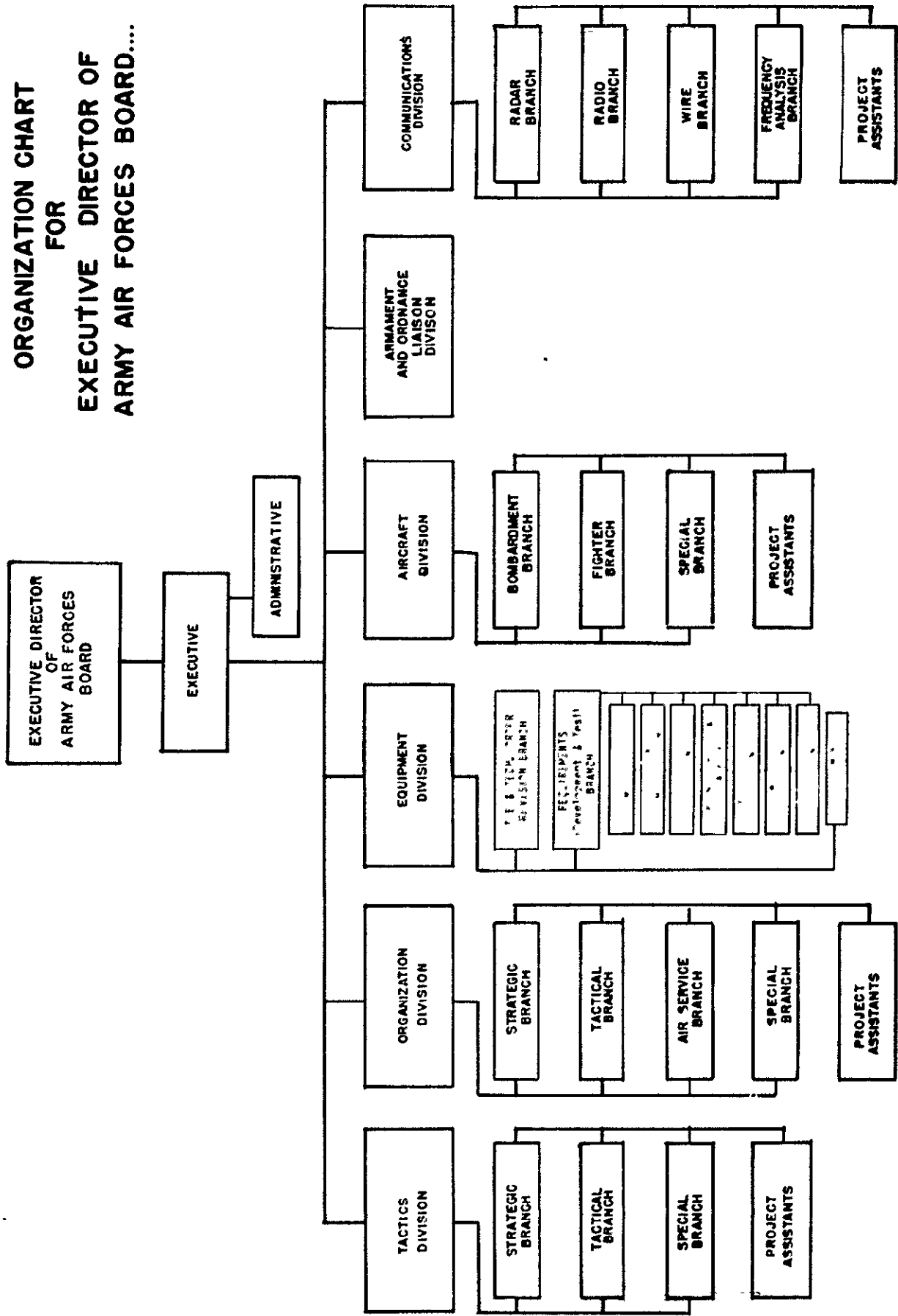

2-461

~~RESTRICTED~~
~~SECURITY INFORMATION~~

32

discussed a plan for an AAF Board with a number of Headquarters officers. The plan, which was pretty generally discussed in Headquarters, contemplated the ultimate assumption of very broad powers by the board. It would have general direction of all test and development activities relating directly or indirectly to tactics and would accordingly coordinate the work of the proving ground and the tactical center. It would determine training standards, issue manuals, establish tables of organization, tables of equipment, manning tables, and would ultimately determine pretty largely military requirements for the AAF. It was thought that in time of peace new tactics would be originated at one or another of the centers under the supervision of the board. In brief, Headquarters would delegate to the AAF Board responsibility for all tactical matters as well as the establishment and maintenance of standards. Obviously, such a plan could not be realized while the AAF was engaged in a global war. It was designed to be a part of the peacetime organization of the AAF. But the concept did undoubtedly influence the later assignment of responsibilities and functions to the AAF Board.⁴¹

The board remained under the authority of the Commandant, AAFSAT until 8 October 1943, when it was set up independently as an agency of Headquarters, AAF with its purpose to develop tactics, techniques,

41. Conversations with Lt. Col. R. D. S. Deichler and Maj. J. S. Kaufman, Management Control; cf. AAG 352, School of Applied Tactics.

~~RESTRICTED~~
~~SECURITY INFORMATION~~

~~RESTRICTED~~
~~SECURITY INFORMATION~~

33

and doctrines and determine all military requirements for the Army Air Forces.⁴² In early 1944 the board functioned under the direction of the AC/AS, OC&R who was its president. The other members were General Eubank, Executive Director in Orlando, and the commandants of the AAF Tactical Center and the Proving Ground Command. In practice, military requirements were still determined by the Requirements Division of OC&R. The board issued only those Training Standards and manuals which were tactical. The degree of control which it would exercise over the Proving Ground Command had yet to be determined. In effect it was an agency of OC&R, and in the latest chart analysis of AAF organization had been shown as part of that office.⁴³

42. AAF Reg. 20-20, 8 Oct. 1943.

43. Organization Chart, "Organization of the Army Air Forces," 1 Apr. 1944.

~~RESTRICTED~~
~~SECURITY INFORMATION~~

~~RESTRICTED~~
~~SECURITY INFORMATION~~

Chapter II

THE DEVELOPMENT OF TACTICS

The Establishment of the Tactical Problem

It is doubtful whether anyone, by a study of the complicated allocations of functions just reviewed, could gain a very clear picture of how the tactics in practical use by AAF flyers actually came into being. Nevertheless, before making any attempt to describe the processes by which tactics have been evolved, it was essential that the general situation be taken into account. For the course of tactical development was but an aspect or a detail of the evolution of the Army Air Forces. The procedures followed in tactical development were determined very largely by the current state of AAF organization and the immediate need to be met.

At once the reader must be cautioned that the word procedures is misleading. For most of the procedures followed were of necessity informal in the extreme. It should be obvious that it is impossible to establish formal channels governing the development of ideas on so elusive a subject as tactics. The practical possibilities of a tactical idea are best explored--in the initial stages at least--through an informal exchange of ideas among experts who are familiar with a variety of elements which must be taken into consideration. Much of this was accomplished informally at Headquarters. Much was achieved

~~RESTRICTED~~

~~RESTRICTED~~
~~SECURITY INFORMATION~~

35

through the same informal procedure at Orlando, among the personnel of the AAF Board and AAFAC. Constant exchange of thought and information took place in similar informal fashion between the personnel of Headquarters, the AAF Board, AAFAC, and other interested agencies.

There are, however, discernible stages in the process of tactical development. The first of these consists in perceiving the opportunity or need for a new tactic and in defining the problem in terms of its various components--material, organizational, and purely tactical. Although, in wartime, tactical problems arise out of combat experience, it is often the case that the men in the theaters of operations do not perceive the possibility of improving a particular situation by resorting to a change in tactics. They are too close to the conflict to see it in perspective, too fully engaged in meeting urgent daily demands for missions and sorties, in planning details of large and small actions, in replacing casualties and damages and keeping up strength and morale, in keeping essential supplies moving, in thwarting the attempts of an active and resourceful enemy to interfere with the carrying out of all these functions. It was necessary, therefore, that Headquarters, Washington, insure that new tactics be constantly developed and that no opportunity for applying a tactical solution be neglected.

Actually, a good tactical idea can originate almost any place within or outside of the AAF. It may develop out of the experience of a commercial pilot. It may derive from tests conducted by a plane manufacturer. An alert instructor in a training center may perceive an

~~RESTRICTED~~
~~SECURITY INFORMATION~~

~~RESTRICTED~~
~~SECURITY INFORMATION~~

36

opportunity for a more skillful employment of a plane or a formation in combat than is the current practice. Most frequently the flyers actually engaged in combat operations, the Headquarters experts who study mission reports and analyses, and the men at the tactical center are those who evolve new tactics. But it is of utmost importance that no source of new tactics be overlooked, and to that end Headquarters must be ever alert to pick up any suggestion which seems promising and to see that it is properly tested and developed. The difficulty of making formal assignment for origination of tactical ideas explains the scattering of tactical responsibility through a large number of organizational units before the establishment of the tactical center. Yet, despite this dispersal of responsibility and the resulting difficulties encountered when it became possible to attempt a concentration and simplification of the organization of tactical development, the performance of American airmen in combat provides evidence of the effectiveness with which tactics were developed under difficult circumstances. Some examples will serve to illustrate how important tactics were initiated.

In May 1942 Headquarters, Washington, became interested in low-altitude bombing as a result of having observed that where the tactic was employed by the RAF the results were a high degree of accuracy combined with a low rate of loss among the attacking planes. This observation led to the perfection of one of the most important tactical developments of the war. A careful study of RAF experience

~~RESTRICTED~~
~~SECURITY INFORMATION~~

~~RESTRICTED~~

37

~~SECURITY INFORMATION~~

was immediately undertaken and a technique for low-level bombing worked out. The problem was assigned to Eglin Field with a request that the Proving Ground Command proceed to develop the technique along with any materiel refinements which seemed necessary.¹ Attached to the Proving Ground at Eglin Field was Col. Sargent Prentiss Huff who, as early as 1925, had foreseen the possibilities of low-level bombardment once planes had achieved requisite speed and bombs and fuses had developed to a sufficient point.² By 3 July 1942 it was clear that the technique devised was correct. On that date, while the Proving Ground was still working out refinements of the technique, the Director of Bombardment sent cables to the commanding officers in the theaters of operations describing the technique and recommending its adoption.³ Only two theaters were interested in the information. The Alaskan theater made the first American use of the tactic in the Aleutians with marked success. However, this first success was overshadowed by the spectacular victory which attended its employment by the Fifth Air Force in the Battle of the Bismarck Sea, 1-4 March 1943.⁴

More recently, a departure from established tactical procedure was conceived in planning the bombing attack on the Floesti oil fields

-
1. Interview with Col. H. G. Montgomery, Jr., Chief, Tactics Division, AAF Board, 8 Nov. 1943. Copy in AFIFI files.
 2. Colonel Huff was awarded the Legion of Merit in recognition of his contribution to the development of minimum-altitude bombing. WD GO #30, 12 June 1943.
 3. Interview with Colonel Montgomery.
 4. Ibid.

~~RESTRICTED~~

~~RESTRICTED~~
~~SECURITY INFORMATION~~

38

in Romania which was carried out on 1 August 1943.⁵ Here the non-success of the Russian attempts at night bombing of the field posed a tactical as well as a strategical problem. Naturally, high-level precision bombing of the fields was considered. However, the distance to the fields was great. The bombers would be exposed to concentrated enemy attack by fighter planes and a reinforced anti-aircraft defense. In order to complete the destruction of the fields, the operations would have to be continued over a considerable period of time, during which the enemy would be enabled to concentrate his defensive resources to protect this supply of vitally necessary oil. The cost of prolonged high-level attack on the fields would be high, the results long-deferred.

But here again Headquarters planners were able to draw upon combat experience in envisaging the employment of heavy bombardment aircraft in a mass attack at zero altitude, one which would complete the destruction of the oil fields in a single blow. Maj. Norman G. Appold, the commanding officer of one squadron of the 376th Group, had made a successful low-altitude attack against the ferry slips at Messina, Sicily, and against a chemical plant in the vicinity of Naples. But what was unique in the plan proposed by Col. J. E. Smart of General Arnold's Advisory Council was the employment of five heavy bomb groups in one mass low-level attack. Intensive train-

5. Memo for Joseph Reither, AFIHI, by Col. J. E. Smart, Advisory Council to CG, AAF, 10 Jan. 1944, in AFIHI files.

~~RESTRICTED~~
~~SECURITY INFORMATION~~

~~RESTRICTED~~
~~SECURITY INFORMATION~~

37

ing was necessary before even highly experienced flyers could be entrusted with the application of so hazardous a tactic. The result, however, was the destruction of approximately 3,935,000 tons of refining capacity.⁶

Many times, of course, a tactical problem arises from the fact that a new weapon has been developed. It then becomes necessary to test the possibilities of the weapon and determine how it may be most efficiently employed before it is turned over to the men who will use it. An outstanding example of this type of tactical project is that covered by the AAF Board Report (M-111), Tactical Employment Trials on the Republic Airplane P-47-C, 16 February 1943.

Rumors of the exceptional performance of the new Republic airplane, which became known as the Thunderbolt, circulated widely while the plane was still in the developmental stage. In response to a suggestion conveyed informally to Washington from Orlando, General Fairchild, Director of Military Requirements, authorized the development units of the Fighter Command School to conduct tactical tests in April 1942.⁷ At that date, however, the plane had not yet reached a stage of production suitable for test by the tactical center. It was not until September, after the plane had been subjected to various tests by the Materiel Center at Wright Field and by the I Fighter Command at Eglin Field, that production aircraft were ready

6. See AAF Historical Studies: No. 6, The Ploesti Mission, 1 August 1943.

7. Interview with Lt. Col. Charles W. Stark, Chief, Fighter Branch, Aircraft Division, AAF Board, 10 Nov. 1943, in AFIHI files.

~~RESTRICTED~~
~~SECURITY INFORMATION~~

~~RESTRICTED~~

40

~~SECURITY INFORMATION~~

for investigation by the tactical center. Six production aircraft reached Orlando in October, and tests were begun. The final report, completed 16 February 1943, was prepared by the new tactical center in a manner which would assure its being read with interest. Headquarters considered the report excellent, and General Arnold telephoned General Peabody stating the 1,000 copies would be needed at once. The success of this complete report on the tactical employment of a new plane resulted in a request for similar studies to be made of new models of planes already in use.⁸

An interesting example of the way in which a tactical problem was posed by a contemplated military action is that of the demand for a mobile aircraft warning and control system to be employed in the Allied landing in North Africa. In the early summer of 1942, air warning and control, involving radar and various types of radio communications, had developed as fixed-type installations. But the operation being planned for North Africa revealed the need for an air defense system adaptable to a mobile situation.⁹ Aircraft warning and control systems, as they then existed, were cumbersome, heavy, and still in a highly experimental stage of development. However, sufficient progress had been made so that it was reasonable to believe that a mobile system could be worked out.

8. Ibid.

9. Interview with Lt. Col. Walter E. Lotz, Jr., Chief, Headquarters Division, Communications Department, AAFSAT, 10 Nov. 1943, in AFHFI files.

~~RESTRICTED~~~~SECURITY INFORMATION~~

~~RESTRICTED~~
~~SECURITY INFORMATION~~

41

On 8 July 1942, Colonel Saville, Director of Air Defense, Washington, issued a directive to the President of the Air Defense Board through the Commanding Officer, Fighter Command School, assigning the project. He defined a mobile situation as

one in which, in a theater of operations lacking an integrated air defense, early warning and some measure of control is required in order to prevent enemy aircraft from seriously hindering our operations. Such a situation would exist were we to attempt an invasion of Africa in the vicinity of Casablanca, for example. It would not exist in an invasion of Martinique. It might not exist in an invasion of France from Britain.¹⁰

Consideration was to be given to the question of making warning and control equipment air-transportable, truck-transportable, or both. The immediate requirement was that a theoretical solution be worked out capable of application as soon as sufficient materiel became available. There was no time to develop new equipment; it was necessary to adapt that which existed. The Fighter Command School was charged with: (1) designing the system; (2) investigating all available radio equipment; (3) improvising light weight radars; and (4) determining the organization and training of new units. The project called for an "air transportable" air defense system to be "in the hands of using troops on September 30, 1942." However, at the time this requirement was established, Colonel Saville stated that probably one time out of ten the system would be moved into combat via

10. Director of Air Defense to President, Air Defense Board, Fighter Command School, Orlando, Fla., 8 July 1942, in AFHFI files.

~~RESTRICTED~~
~~SECURITY INFORMATION~~

~~RESTRICTED~~

42

~~SECURITY INFORMATION~~

air; the other times it would go in by assault boat.¹¹

Of course the tactical center constantly studied enemy tactics and maintained a close scrutiny of the tactical situations existing in the theaters. Intelligence reports were carefully reviewed, but the most intimate liaison was maintained through consultation with theater personnel. Flyers returned from the theaters of operations were immediately sent to Orlando where they were closely questioned with respect to their combat experience--the tactics most frequently employed by the enemy, the measures most successful in countering enemy attacks, performance of planes under varying conditions of weather, altitude, and stress. It was this information, tested in flight over Orlando, which enabled the experts at the tactical center to decide upon the best measures for meeting the enemy in the air. These measures were embodied in such AAF Board reports as Indoctrination of Fighter Pilots in Best Approach Angles for Attacking Enemy Aircraft, or Tactical Use of Fighter Aircraft in Close Support of Heavy Bombers, or again, Fighter Formations--Combat.¹²

-
11. Draft report of conference in Washington, D.C., attended by Colonel Saville, Director of Air Defense; Col. Thomas J. Cody, SC, Project Officer; Lt. Col. Robert L. Schoenlein, AC, Executive, Air Defense Board; Lt. Col. Joseph D. Lee, Jr., AC, Fighter Command School; and L. A. Dorf, Technical Adviser, 24 Aug. 1942, in AFIFI files.
 12. Projects (T-1)5, (T)5c, changed to (T)5b, and (T-2)16, listed in Report on the Status of Army Air Forces Board Projects for the Month Ending 15 January 1944. This is the first monthly report which includes descriptive titles of secret projects.

~~RESTRICTED~~~~SECURITY INFORMATION~~

~~RESTRICTED~~~~SECURITY INFORMATION~~

43

Finally, there are certain continuing tactical situations that are subject to constant change which must be studied unremittingly in order that any alteration in the situation which presents a tactical opportunity may be seized immediately. Such is the problem of landings on enemy coasts. While there are certain tactics which are basic in any such landing operations, particular cases present special problems of their own. The reef-ringed beaches/^{of}low-lying equatorial islands offer very different hazards from those encountered on the open but shallow beaches of the Italian coast. Enemy tactics, equipment, and defense vary from place to place and from month to month. To meet such situations, the AAF Board maintained continuing projects out of which new tactical adjustments flowed. On 10 July 1943 OC&R assigned to the board the "Development of Technique for the Passage of Beach and Underwater Obstacles." This project was set up as a staff study by the board and as late as February 1944 was still under continuous review. A further project was launched on 17 September 1943 to bring about the "Development of Offensive Tactics Versus Japanese Fortifications." This project was assigned to AAFTAC by the AAF Board and was classified "continuous until complete." On 16 November 1943, Headquarters assigned as a project to the board the "Command and Employment of Air Power in Joint Amphibious Operations." This was set up as a board staff study, and a first phase report was written on 23 December 1943.

13

13. Projects (T-2)7, (T-1)13, in ibid.

~~RESTRICTED~~

~~RESTRICTED~~
~~SECURITY INFORMATION~~

44

The above examples illustrate the principle ways in which tactical developments were envisaged and initiated. In two instances, that of the Floesti raid and that of the North African landing, contemplated military actions created demands for new tactics. In another instance, the tactical problem arose out of the creation of a new weapon--the P-47. In still another instance, which resulted in the development of a technique for low-level bombing, Headquarters was able, as a result of close study of foreign aerial missions, to discern the opportunity for employing a new bombing technique that was ultimately perfected at Eglin Field. It has been noted how, through conference with personnel returned from the theaters, the tactical center was able to test the latest enemy tactics and formulate the best means for countering them. And it has also been indicated that certain basic tactical situations, such as landings on enemy coasts, were subject to unremitting scrutiny and test in order that no tactical opportunity be overlooked. Examples could be multiplied almost without limit. And--such is the nature of tactics--each instance would show some variation from the others. But essentially, the procedures described sufficiently indicate the manner in which tactical development was initiated in the Army Air Forces up to February 1944.

~~RESTRICTED~~
~~SECURITY INFORMATION~~

~~RESTRICTED~~

45

~~RESTRICTED~~

The Development of Tactics

The actual conduct of tactical testing and development which takes place at the tactical center is not the concern of this study except insofar as it involves the services of Headquarters, Washington. However, the importance of those services is emphasized again by the fact that the actual problems confronted cannot be typed and subjected to routine developmental procedures. Often a problem involved materiel and organizational aspects as well as tactical. In such cases it became necessary for Headquarters, or an agency of Headquarters such as the AAF Board, to assign the different aspects of the problem as separate projects to different developmental agencies and then to coordinate the results of their work. In other cases, considerations lying entirely outside the scope of the immediate problem imposed limitations upon a particular development. A review of some outstanding projects should be of help in arriving at an understanding of these factors.

AAF Board Old Project No. 38, New Project No. (M-1)2 involved nearly all of the above elements.¹⁴ The YB-40 was a fighter-destroyer airplane designed to furnish protection for heavy bomber forma-

14. Report of AAF Board, Tactical Employment Trials of the YB-40 Airplane, (Old) Project No. 38, (New) Project No. (M-1)2, 21 April 1943.

~~RESTRICTED~~~~RESTRICTED~~

RESTRICTED

46

tions on long-distance missions. It masqueraded as a B-17 and flew as part of a bomber formation. The plane was under development when AAFSAT was created. It was immediately proposed that the new tactical center undertake the running of tests as soon as production aircraft were ready. Late in March 1943, Lt. Col. K. H. Gibson of the Requirements Division of OC&R telephoned AAFSAT and arranged for the tactical center to undertake the running of tactical tests and the training of combat crews for 13 YB-40's.¹⁵

Between 2 and 6 April the planes were flown to Orlando from El Paso, Tex. The crews were immediately subjected to a thorough training program. In order to cut down the training use of the YB-40's to a minimum of about 65 hours, AAFSAT facilities for the training of navigators, bombers, gunners, and pilots were used. Tactical trials and training, which took place at Montbrook, outside of Orlando, were finished 18 April 1943. A report dated 21 April was submitted and a copy of this report accompanied the planes to the United Kingdom although the report was not actually published until 15 May 1943.

Here was a project which involved training and organizational aspects, materiel aspects, and tactical aspects. The YB-40 was a modified and armored B-17. The tactical center was assigned the task of appraising its worth as a destroyer-fighter, of recommending modifications to perfect its performance, of giving transition and tactical training to the newly assigned operational training unit

15. Interview with Colonel Montgomery.

RESTRICTED

~~RESTRICTED~~
~~SECURITY INFORMATION~~

47

crews allocated for the project, and of determining the proper tactical employment of the craft. That the plane was not considered the final answer to the need for escort fighters for heavy bombers is indicated by the report itself, which stated:

Opinions discouraging the fighter-destroyer should not be based upon the YB-40. Rather, all effort should be made to use this airplane as a basis for recommendations for the fighter-destroyer of the future, as it is believed that this type of aircraft will be capable of and necessary to escort all bombing missions beyond the range of local fighters.

Nevertheless, the personnel of the tactical center were interested in the plane as a step toward the development of the fighter-escort of the future and were naturally anxious that its recommended modifications be incorporated in the plane and that a full report of its performance in the theater be made at as early a date as possible.

However, other factors influenced Headquarters in its arrival at a decision to send the planes to the theaters at once without further modification. Modified fighter craft, with auxiliary gasoline tanks which would enable them to accompany long-range bombers as fighter-escort, were then under development. Any considerable production of fighter-destroyers or the conversion of B-17's into YB-40's would have forced a curtailment of bomber production, and this was not desired. It was immediately necessary to furnish some kind of escort protection to heavy bombers in the theaters of operations, and Headquarters was satisfied to use the YB-40's as a temporary solution to this problem. The planes were immediately dispatched to the Eighth Air Force, and a copy of the AAFSAT recommend-

~~RESTRICTED~~
~~SECURITY INFORMATION~~

~~RESTRICTED~~
~~SECURITY INFORMATION~~

ations as to modifications and tactical employment accompanied them.

After a period of experimental use by the Eighth Air Force, one YB-40 returned to the United States, modified in accordance with the 8th Bombardment Group's recommendations which were practically the same as AAFSAT's, and was sent down to Orlando for further test. Ultimately the remaining planes were returned to the United States. After thorough test by the Proving Ground, the AAF Board endorsed the Proving Ground recommendation of 6 November 1943 that the production and use of the YB-40 airplane be discontinued. The reasons for this recommendation were chiefly that:

1. The YB-40 was originally designed to offset the lack of long-range fighter planes to protect bombers. Fighter planes capable of accompanying B-17's and B-24's on long-distance missions had since been developed.
2. The features which rendered the YB-40 especially formidable--two extra guns, extra armor, extra ammunition, a chin-turret for protection against frontal attack--had most of them been embodied in the B-17, rendering it formidable to attacking fighters but leaving it still a bomber.
3. The YB-40, because of the extra weight of armor, armament, and ammunition, was seriously slowed down by the disabling of one of its motors. To a much greater extent than the B-17 it was, in these circumstances, forced to break formation and was in such case worse off than a B-17 with one damaged motor. 16

This project revealed the rapidity with which tactical test and training could be conducted; only 15 days elapsed between the time the planes reached Orlando and the date when they were ready for dispatch to the theater, provided with completely trained crews and complete recommendations upon the tactical employment of the craft.

16. Ibid.

~~RESTRICTED~~

~~RESTRICTED~~
~~SECURITY INFORMATION~~

49

Despite the sound recommendations made by the tactical center covering modification of the plane, Headquarters decided to speed the planes to the theater of operations without waiting for the modifications to be made. ¹⁷ That this decision was a wise one is demonstrated by the subsequent history of the YB-40. The fighter-destroyer took the enemy by surprise and did furnish protection to the Eighth Air Force's big bombers during the interval when long-distance fighters were being developed. But perhaps the greatest contribution made by the YB-40 was that it made possible the improvement of the B-17, rendering that plane much more formidable to attacking fighters while it remained primarily a bomber.

In this case, however, as in many other instances, the tactical center was not informed of the practical consequences of the application of its recommendations in the theater. Through random intelligence reports and from contact with personnel returned from the theater, it was learned at AAFSAT that theater criticism of the YB-40 corresponded exactly with its own. In this case and in others, it would have been of considerable value to the tactical center if it had been given an early report upon the extent to which its recommendations were applied in the theaters along with a comment on the results obtained. In like manner, reports on any modifications made in the application of tactical recommendations and the reasons for them would have been of value.

17. Ibid.

~~RESTRICTED~~
~~SECURITY INFORMATION~~

~~RESTRICTED~~
~~SECURITY INFORMATION~~

50

In many instances projects assigned to the tactical center involved the complete investigation of the tactical employment of a new item of materiel. One of the first projects assigned to AAFSAT at the time of its establishment was of this nature. AAF Board Old Project No. 23, New Project No. (M-1)1, the tactical employment trials on the Republic P-47C,¹⁸ was carried through to completion during a period of important organizational change both at the tactical center and at Headquarters, Washington. Production aircraft were not available for tactical test until the fall of 1942. On 27 September General Saville gave verbal instructions to Col. Joseph D. Lee, Jr., and Lt. Col. Charles W. Stark to proceed with tactical suitability trials on the P-47C.¹⁹ At that time tactical tests were being handled, when needed, by the 81st Fighter Squadron, 50th Fighter Group, of the Fighter Command School at Orlando.

In October 1942 six production aircraft were received in Orlando, and tests were begun. Since the report on the tactical use of the new plane was to be written for the use of pilots of varying degrees of skill and experience who had never seen the plane before, it was desired that the tests be conducted under conditions which would approximate as closely as possible the conditions under which they would be used. Accordingly, tests were made with production aircraft,

18. Report of AAF Board, Tactical Employment Trials on the Republic Airplane P-47-C, (Old) Project No. 23, (New) Project No. (M-1)1, 16 Feb. 1943.

19. Interview with Colonel Stark.

~~RESTRICTED~~

~~RESTRICTED~~
~~SECURITY INFORMATION~~

51

under all sorts of flying conditions, with pilots of varying grades in charge of the planes.²⁰

It was equally important that the recommendations of the tactical center be presented in such a fashion as would insure their being read with interest and full attention. Since the reports being issued by the RAF Development Unit in England were being prepared in a manner conducive to interested reading, it was arranged that W/C I. Campbell-Orde, Commanding Officer, RAF Development Unit, be sent to AAFSAT to act as adviser to Colonel Stark in the preparation of AAFSAT's recommendations on the tactical employment of the new plane.

The report on the tactical employment of the P-47 was issued on 16 February 1943. On 17 March General Saville wrote that it had been carefully studied and was considered excellent.²¹ General Arnold telephoned General Peabody, Commandant of AAFSAT, indicating his desire that the recommendations be placed in the hands of theater personnel as quickly as possible.²² This report is interesting because it was the first time that the new tactical center was called upon to make a complete study of the tactical suitability of a new plane. The collaboration of an RAF officer in the presentation of the report, thus making available to AAFSAT the skill and experience of an Allied service, is also an item worthy of note. But here, once again, AAFSAT was allowed to rely on random intelligence reports and contacts with theater personnel for knowledge of the extent to which experience in the theaters

20. Ibid.

21. Brig. Gen. G. P. Saville, Director of Air Defense, to Commandant, AAFSAT, 17 Mar. 1943, in AFIMI files.

22. Memo for L. A. Dorf by [Capt. Trygve Sandberg], [9 Nov. 1943], in AFIMI files.

~~RESTRICTED~~~~SECURITY INFORMATION~~

~~RESTRICTED~~

52

confirmed its own judgment and recommendations upon the tactical use of the plane.

AAF Board Project (T-5)13²³ is an example of an instance in which the time factor was an element of such importance that it was not possible to deal with the various aspects of the problem separately. The materiel, tactical, organizational, and training phases had to be dealt with at the same time, at the same place, and in most instances by the same people. The project is also an example of a problem which was so basic in character that its progress revealed requirements for the setting up of subordinate and derivative projects in considerable number.

A mobile warning and control system was first conceived in connection with the project of a landing on the North African coast. The project referred to above was assigned to the Air Defense Board through the commanding officer of the Fighter Command School on 3 July 1942. The requirement was that an air-transportable system be in the hands of using troops on 30 September 1942. It was realized that no matter how sound a system might be evolved, the necessity for constructing makeshift equipment from the limited amount of apparatus available might produce practical results of very doubtful value. As a result of these considerations, two projects were launched, a short-range project which was to be completed by the end of September and a long-range project to be finished "as soon as possible."²⁴

23. Report of AAF Board, Mobile A. u. Control System, Project (T-5)13, 1 Nov. 1943.

24. Interview with Colonel Lotz.

~~RESTRICTED~~

~~RESTRICTED~~
~~SECURITY INFORMATION~~

53

The system designed for the immediate project proved to be sound, for after a year's work in operational development essentially the same system was employed. Radio equipment provided the units was poor because in the short time available to complete the project it was necessary to procure radio sets already manufactured and available in sufficient quantities for that purpose. The radars provided were poor in that they had deficiencies which limited their operational performance. But it is important that the radars developed were the first operational radar sets in the light-weight, highly transportable field; and considering that those radars were developed by military personnel, with a minimum of technical assistance from civilian scientists, the contribution of these radars to the ultimate completion of the project was extensive in that they proved what could be done in the radar field if the proper brains and development facilities were allocated to the task.²⁵ The units organized to operate this pioneering mobile system received a bare minimum of training. In the case of one battalion, only 10 days were available to organize, equip, train, and ship that unit to the port of embarkation.

In the North African landing no actual test was made of the value of the new units in fulfilling their mission. One battalion was landed with hastily improvised equipment because its own equipment was left in the United States due to lack of required shipping space. Another unit had its personnel landed at one point and its equipment at another port several hundred miles away. A portion of the third battalion was

25. Ibid.

~~RESTRICTED~~
~~SECURITY INFORMATION~~

~~RESTRICTED~~~~SECURITY INFORMATION~~

54

utilized as assault infantry troops for unknown reasons, and another portion was denied permission to land at the proper time to fulfill its mission. All these factors were beyond the control of the unit commander and those conducting the project. However, although the mobile air warning and control system contributed nothing to the military enterprise for which it was originally designed—the actual landing operation—the system devised, which was sound, laid the basis for enormously important developments in detection, warning, control, and communications achievements which contributed largely to the perfection of the tactical air force.²⁶

Inevitably the work of the immediate project and that of the long-range project became merged. It had become necessary to manufacture apparatus at Orlando in order to meet the urgent requirements of the immediate project, and available parts and equipment were used and adapted to the needs of the system. The need for special equipment and of especially trained personnel was acute; consequently a request was addressed to the office of the Director of Air Defense, Headquarters, for authorization to obtain the special assignment of needed personnel. The authorization was given 15 December 1942.

In the summer of 1942 it had seemed advisable to employ frequency bands that had not yet been used by the Army and the Navy. This course was followed. Through the month of November field testing was conducted at the tactical center to try all radio equipment then being studied. Radar projects were initiated at Belmar (near Orlando) to meet the

26. Ibid.

~~RESTRICTED~~~~SECURITY INFORMATION~~

~~RESTRICTED~~
~~SECURITY INFORMATION~~

55

requirements of the project. Headquarters, Washington, was kept fully informed of the progress and difficulties that were being experienced.

In 1942 the field of electronics was a very new field indeed. What had been accomplished in aircraft warning and control represented pioneering achievements. Although significant advances were being made in all quarters of the field, scientific knowledge of and experience with the various aspects of the subject were limited and scattered. In view of this situation, the Director of Air Defense in Headquarters arranged for a meeting of interested AAFSAT and Signal Corps personnel with members of the National Defense Research Council in Washington in January 1943. The tactical problem was described to the meeting by General Saville. Incidentally, this was the first occasion on which a complete tactical picture was given to the National Defense Research Council in connection with the technical problem presented to it. Colonel Lee, Lt. Col. W. E. Lotz, and L. A. Dorf outlined the system that had been devised by AAFSAT.²⁷ Reports on the planning for the North African project served to give definition to the problem which was then thoroughly discussed.

Following the meeting, on 1 February 1943 a subcommittee of NDRC was formed which lent a degree of cooperation and support that was an important factor in the progress of the project from this point forward.²⁸ A field laboratory was established at Orlando, and distinguished radio

27. Ibid.

28. Memo for the files (Subject: Sub-Committee on Air Transportable Communication Equipment for Aircraft Warning System) by Lt. Col. W. D. Inness, Chief, Installations and Maintenance Section, Directorate of Communications, 5 Feb. 1943, in AFPHI files.

~~RESTRICTED~~
~~SECURITY INFORMATION~~

~~RESTRICTED~~

56

experts were provided as advisers. The Signal Corps cooperated in the tests conducted in Orlando by the NDRC of all available equipment. From 18 February to 23 April the work was facilitated by the efforts of a joint committee comprising members of AAF Headquarters, AAFSAT, and the Signal Corps. Men recruited for the battalions were used in conducting the tests. About 1 March 1943 requirements were established.

Around 14 April an airborne fighter control squadron was created and field operations were conducted under combat conditions. The mountainous terrain in the vicinity of Asheville, N. C., was selected for final tests. Results were described in a detailed report forwarded to Washington by Colonel Lotz on 12 June 1943.

The result of the original tactical need envisaged in connection with the North African landings was that a heavy, fixed, defense mechanism was developed into a mobile offensive mechanism involving ultimately the development of new tactical techniques. The solution of the problem tied up with the development of the tactical air force through its control and warning system. The technical aspects of the problem dovetailed with the progress being made concurrently in radar, radio, and communications. The success of the project opened up new fields in air force operations and communications.

In the course of development the over-all project was broken down into a number of subsidiary projects, an example of which is AAF Board Project AN/TTQ-1 through which the SUS-5, weighing 14 tons, was replaced by portable information-center equipment weighing two tons and transportable on a single truck. The over-all project developed two phases, one of which was met by a Light Mobile set, transportable by

~~RESTRICTED~~

~~RESTRICTED~~
~~SECURITY INFORMATION~~

57

aircraft or on landing craft. In landing operations this was to be followed up by the heavier, more efficient equipment embodied in the Intermediate or Road Mobile set.

The complicated project, or series of projects, which grew out of the assignment given the Air Defense Board in July 1942 provides an example of the ramified and often highly informal relationships maintained between Headquarters, the tactical center, and outside agencies whose experience and expert guidance were needed in the course of meeting tactical requirements. It would be incorrect to stress formal channels by describing them, for the fact is that between the formal assignment of a project and the formal presentation of a final report by the AAF Board, the procedure was characterized by a high degree of informality. In general, the personnel at the tactical center knew pretty definitely what expert assistance was needed and where aid could be obtained. Where it was possible by direct negotiation to obtain the temporary assignment to the tactical center of the experts whose advice was needed, this procedure was followed. Where the cooperation of Headquarters would facilitate the securing of the needed help, that collaboration was obtained by the most direct and informal methods. In general, Headquarters was kept informed of the progress of important projects by reports, letters, and personal contact by telephone and in conference. Much the same procedure existed in the obtaining of needed equipment.

The projects that have been discussed were of outstanding importance and were among the first to be developed under the organization set up in November 1942 as the AAF School of Applied Tactics, since redesignated

~~RESTRICTED~~

~~RESTRICTED~~
~~CONFIDENTIAL~~

the AAF Tactical Center. The brief review of the projects given here is sufficient to indicate the high degree of cooperation and collaboration which was maintained between the tactical center and Headquarters, Washington, during the course of the development of the projects. The standard set was very high.

In the course of something more than a year previous to February 1944, during which the new tactical center had been functioning, many projects had been assigned to it. In February 1944 all projects for the tactical center were assigned to the AAF Board by OC&R, with two exceptions. The Materiel Command at Wright Field was permitted to assign projects direct to the AAF Board and to supply needed personnel and equipment in connection with such projects. The AC/AS, Training was also permitted to make direct assignments of projects to the board when they involved training matters exclusively. The number of projects assigned to the AAF Board and the Tactical Center since their establishment is impressive. The report of the AAF Board for the month ending 15 December 1943 listed a total of projects completed to date as 393.²⁹ Seventy-two projects were brought to completion during the period 15 November to 15 December. During that same month 108 new projects were activated, raising the total of projects current on 15 December to 294. The total of projects current plus the total of projects completed made a grand total of 687. The board report of 15 December 1943 did not show the distribution of projects between the Tactical Center and the Proving Ground. However, the board report

29. Information supplied by Maj. R. A. Fisher, AAFTAC Representative, Liaison Division, AC/AS, OC&R.

~~RESTRICTED~~
~~CONFIDENTIAL~~

for 15 January 1944 revealed that of a total of 371 projects current, 96 were being conducted by the Tactical Center, 147 by the Proving Ground Command, and 102 jointly by these two agencies. The remaining projects were either board staff studies or special projects being developed elsewhere.³⁰

It was obviously impossible that the same degree of intimate liaison could have been maintained between Headquarters, Washington, and the Tactical Center on each and every one of these projects. It should be noted, too, that a large number of the projects listed were subordinate and derivative. The initial assignment of the development of a mobile air warning and control system, for example, was ultimately broken down into a number of separate projects, all of which were covered in some degree by the liaison maintained with Headquarters. Despite the rapid increase in the number of projects being developed at Orlando, close cooperation was maintained. On 13 December 1943 there was established in the office of AC/AS, CC&R an AAF Board Control Office, the function of which was to facilitate understanding and cooperation between the two responsible offices.³¹

30. Report on the Status of AAF Board Projects for the Month Ending 15 December 1943.

31. Office Memorandum for all divisions and branches of CC&R by AC/AS, CC&R, 13 Dec. 1943, in AFHQ files.

~~RESTRICTED~~
~~SECURITY INFORMATION~~

~~RESTRICTED~~
~~SECURITY INFORMATION~~

Chapter III

TACTICAL INTELLIGENCE

Assembling and Use of Tactical Information

Headquarters ultimately determines tactical requirements and tactical doctrines for the air forces. In order to perform that function it is necessary that at all times there be available at Headquarters full and accurate information relating to the tactical situations currently confronted or likely to be encountered in the future by the men who fly the planes. The obtaining, reporting, accumulating, and classifying of this information was the function which in February 1944 was carried on by the Tactical and Technical Branch of the Informational Division of the office of the AC/AS, Intelligence.

It should be obvious that AAFTAC, the agency charged by Headquarters with the task of testing and developing tactics, is equally dependent upon full, current tactical information if it is to perform its service properly. Unfortunately this fact has not always been fully understood. The reasons for the failure to appreciate the relationship of adequate tactical information to efficient tactical development are not difficult to discover. Prior to the creation of the Air Corps Board in 1934 the whole question of tactics and tactical doctrine was handled rather informally. The Air Corps was small.

~~RESTRICTED~~

~~RESTRICTED~~
~~SECURITY INFORMATION~~

Its personnel were bound together by exceptionally close personal relationships. The speed and mobility of the airplane made the maintenance of direct personal contacts easy as well as pleasant. The result of all this was that there were many informal exchanges of tactical information among Air Corps personnel and that many problems were worked out in informal conversations and with a minimum employment of the tedious routines of office procedure. The convenience of these informal processes is obvious. Their disadvantages are equally clear.

A record of the conferences at which important tactical projects were put forward and discussed in detail by men possessed of a rich background of flying and military experience might have proved of inestimable value had they been available for consultation and study by less experienced men during the period when the air force was undergoing rapid expansion. A permanent record of these discussions and of the tactical information upon which they were based might also have helped to standardize the tactical training of new flyers. But it was a long time before tactical development became formalized.

During World War I an Advisory Board studied all important Air Service questions, including tactical, and advised the Chief of the Air Service upon them. In 1922 there was created an Air Service Board which officially continued in existence until it was replaced by the Air Corps Board in 1924. The functions assigned to the board were very general: "The purpose of the Air Service Board is to consider

~~RESTRICTED~~
~~SECURITY INFORMATION~~

such subjects pertaining to the Air Service as may be referred to the Board by the Chief of the Air Service and to originate and submit to the Chief of the Air Service recommendations looking to the improvement of the Air Service."¹

By 1934 the Air Corps Board was enjoying little more than a legal existence with the result that in July of that year the Baker Board, then investigating the Air Corps, recommended "the early creation of the Air Corps Board and that when created this Board give prompt attention to the formulation of uniform tactical doctrines for all types of Air Corps units."² In addition the committee recommended "the creation of a model Air Corps unit at the Air Corps Tactical School for demonstration and exercises in the training of student officers and for cooperation with the Air Corps Board in the development of tactical doctrines." As a result of these recommendations and in accordance with suggestions made by the Plans Division, CGAC,³ there was established in November 1934 the Air Corps Board. However, it was decided in the spring of 1935 that

-
1. AR 95-20, 1 Aug. 1922.
 2. Final Report of the War Department Special Committee [Baker Board] on Army Air Corps, July 19, 1934, 72.
 3. AR 95-20, 9 Nov. 1934; memo for C/AC by Plans Division, CGAC, 24 Aug. 1934, in AAG 334.7, A.C. Board (Special).

~~RESTRICTED~~

~~SECURITY INFORMATION~~

~~RESTRICTED~~
~~SECURITY INFORMATION~~

until more personnel are available for appointment to the Air Corps Board, it will devote itself to formulating a uniform tactical doctrine for all types of Air Corps units. As a basis for study the Board will use the types and numbers of aircraft now in existence in the Army Air Corps, or on order, and the types and models which are standard and, therefore, capable of production, should cover the functions of the Air Force as a whole and of its separate classes, the organization and composition best suited to accomplish the functions, the ground facilities required, and the general methods of operating.⁴

It was the training angle, the translation of tactical doctrine into practice, which was emphasized in the Baker Board Report and in the Air Corps policy deriving therefrom. The agencies employed in the actual test and development of tactics at Maxwell Field and later at Orlando were schools: the Air Corps Tactical School and the Fighter Command School. This emphasis upon instruction later affected the attitude of the office of the AC/AC, Intelligence in the matter of supplying complete and current tactical information to the tactical center at Orlando.

Another factor which explains the failure to realize the full extent of the tactical center's dependence upon complete tactical information is the practice which was resorted to of necessity during the interval when there was no functioning tactical center.

4. 1st Ind. (basic unsigned to C/AC, 5 Feb. 1935), C/AC to President, Air Corps Board, 13 March 1935, in AAG 334.7, A.C. Board (Special).

~~RESTRICTED~~
~~SECURITY INFORMATION~~

~~RESTRICTED~~
~~SECURITY INFORMATION~~

During that interim period the directorates maintained full control of tactical development and a close supervision of the actual tests. The services of tactical intelligence were directed, therefore, to supplying Headquarters with complete and current tactical information. The needs of a tactical center for adequate sources of tactical intelligence were not confronted during the first year of the country's involvement in war, for AAFSAT was not established until November 1942.

When, during the winter of 1942-1943, preparations were being made for the decentralization of the AAF and the assignment of many directive responsibilities to lower echelon organizations, it was realized that Headquarters would have to retain a considerable degree of control over the definition and assignment of tactical projects. It was not easy to determine all at once just what degree of supervision and direction ought to be surrendered to AAFSAT, especially as the new center needed time in which to round out its organization and to organize its functioning. And as it was difficult to determine at once to what extent the tactical center would assume the direction of the responsibilities assigned to it, the corollary problem of intelligence was difficult to clarify.

Again, as was the case in 1935, the first emphasis was upon training. The most obvious and pressing need was for the establishment of training in tactics for air force officers. The new center was accordingly called the Army Air Forces School of Applied Tactics, its training function being emphasized in its name. But the function

~~RESTRICTED~~
~~SECURITY INFORMATION~~

~~RESTRICTED~~
~~SECURITY INFORMATION~~

assigned to it was a double one: training and tactical test and development.

Sources of reference material on tactics which were immediately available to the newly created center were, first of all, the digests made at the Air Corps Tactical School library at Maxwell Field during the spring of 1942. For although the activities of the school were then suspended, the librarian continued to collect tactical information in anticipation of the re-establishment of a tactical training program.⁵

In December, the Training Literature Section of the Directorate of Individual Training was transferred to Orlando and became the Training Aids Directorate of AAFSAT. The Training Literature Section brought with it a collection of reports which it had assembled or directed at AAF Headquarters, between 5 September and 10 November 1942. These too had been collected in anticipation of the reactivation of an AAF tactical school. There was also turned over to the center a collection of manuals and instruction books on radar, provided chiefly by the RAF for the use of the Fifth Interceptor Command and later⁶ of the Fighter Command School at Orlando.

5. See interview with Capt. G. C. Robinson.

6. Memo for Joseph Reither, AFPHI, by Lt. Harry H. Ransom, AAFAC, Dec. 1943, in AFPHI files.

~~RESTRICTED~~
~~SECURITY INFORMATION~~

~~RESTRICTED~~

But in January 1943, the new Training Aids Directorate at AAFSAT confronted a confused situation with respect to obtaining A-2 information.⁷ An AAF Regulation of 1 January 1943 provided that "The Assistant Chief of Air Staff, A-2, Headquarters Army Air Forces, will collect and supply the Training Aids Directorate, AAFSAT, with all available intelligence information which may bear on aircraft tactics and operations, training methods, synthetic devices, and recognition of aircraft, combat vehicles, and naval vessels."⁸ This was broadly interpreted by the directorate, which requested copies of every kind of information A-2 had. The result of this sudden heavy demand upon A-2 for all kinds of intelligence information was, as might have been expected, a considerable delay in filling the request.

The physical consolidation of all intelligence activities at AAFSAT took place in March 1943 and on the twenty-eighth of that month the AAFSAT library was formally established. At that time there was turned over to it a collection of reports, often duplicating those in the Training Aids Directorate collection, which had been accumulated at AAFSAT since 10 November 1942.

-
7. Interview with Lt. Col. Robert G. Storoy, Chief, Intelligence Department, AAFSAT, 11 Nov. 1943, in AFTHI files.
 8. AAF Reg. 50-19, 1 Jan. 1943.

~~RESTRICTED~~
~~SECURITY INFORMATION~~

In coordinating the library facilities with the work of the newly consolidated center, Lt. Charles D. Chamberlin, executive officer of the library, conducted a study which revealed the extent of the time-lag in the sending of intelligence information to AAFSAT.⁹ The average time-lag at that time was about three months. In order to improve this situation, Col. Percy M. Barr came down to Orlando from Washington and acquainted himself with the informational needs of AAFSAT. It was observed that one of the reasons for the delay in passing on ^{tactical} information from the theaters was the time required for the reproduction of reports in quantities sufficient for distribution to all organizations requesting such information. In order to cut down the reproduction of intelligence information, it was decided that A-2 would issue an accessions list on the basis of which specific items would be requested. Colonel Barr proposed that combat reports be routed to AAFSAT immediately upon receipt from the theaters and Colonel Sorensen, AC/AS, Intelligence, agreed to frame cables requesting special information from the theaters when needed.¹⁰

In practice, however, it was found that from three to six weeks were consumed in making out the accessions list and in effecting deliveries of the material to AAFSAT. As a result of this, on 4 June 1943, General Peabody wrote to the AC/AS, intelligence reporting upon

9. Interview with Col. Storey.

10. Revision of AR 95-20, 9 Nov. 1934. For correspondence relating to this revision see AIG 334.7, A.C. Board (Special).

~~RESTRICTED~~

~~SECURITY INFORMATION~~

11

the time-lag to be overcome. A new study revealed that over 30 per cent of all documents received during the month of May were more than three months old, and over half of the 964 intelligence publications received during that month were three months old or older--7 per cent of them were dated prior to October 1942.

About this time an incident occurred which sharply emphasized both the dangers of out-of-date intelligence and Headquarters' failure to appreciate the importance of current intelligence to the School of Applied Tactics. Lt. Walter R. Hoagher, of the library staff at AAFSAT, published the first of several monographs on enemy aircraft in June 1943. The monograph was issued as AAFSAT Intelligence Digest No. 1, Messerschmitt 109-G. A copy of this study reached the Tactical and Technical Branch of the office of the AC/AS, Intelligence, which protested that it was not proper for AAFSAT to issue studies of this type since Headquarters was much better supplied with relevant data and was in general better equipped for the job. With this latter point the people at AAFSAT were not disposed to take issue. Their concern was a practical one, to see that the job was done so that the men about to be sent into the theaters would be acquainted with the types of fighter aircraft that would be opposed to them. One month later, A-2 in Washington issued a study on the Messerschmitt 109-F, an earlier model than the 109-G, although it was likely that by the time the flyers then being trained would have

11. Gen. Peabody to AC/AS, Intelligence, 4 June 1943. Copy in AFHFI files.

~~RESTRICTED~~

~~CONFIDENTIAL~~

~~RESTRICTED~~

~~RESTRICTED~~ 12
reached the theaters, the later model would be the one to be met.

Like obstacles were encountered with respect to other types of intelligence. Certain kinds of information needed by the Director of Tactical Development and the AAF Board were often difficult to obtain. Requests were made for late information concerning certain enemy defenses and other secret information. The Library also requested specific technical information which was to be used in the consideration
13
of projects of the AAF Board.

On 9 June 1943 General Sorenson addressed a letter to the Commandant, AAFSAT, in which he stated:

It is, at present, impossible to send one copy of all combat reports and periodical intelligence summaries to the School of Applied Tactics immediately upon receipt by this Headquarters. Reproduction is necessary in many cases where only one copy is received here. This causes obvious delay. The immediate need of the School of Applied Tactics for information of this nature is appreciated, however, as well as the inadequacy of the past system.¹²

General Sorenson then proposed that AAFSAT place in the office of the AC/AS, Intelligence a full-time liaison officer whose duty it would be to arrange for the prompt dispatch to Orlando of reports of value to the tactical center. This was done. After the appointment of Maj. Thompson Dean as liaison officer the situation improved greatly. A comparison between receipts of intelligence documents in May and October revealed a most satisfactory improvement. In May only 13 per cent of the material received could be classified as recent, that is, as having

12. Interview with Col. Storey.

13. Ibid.

14. 1st Ind. (Gen. Peabody to AC/AS, Intelligence, 4 June 1943), Brig. Gen. E. P. Sorenson, AC/AS, Intelligence, to Comdt., AAFSAT, 9 June 1943, in AFHQ files.

~~RESTRICTED~~

~~RESTRICTED~~

70

been received within eight weeks of the date of issuance. In October the material that fell into the classification "recent" amounted to 15 78 per cent of total receipts.

The time-lag however, was but one aspect of the informational problem which confronted the tactical center. Another element in the problem was the kind of information being made available to AAFSAT (after 8 October 1943, AAFAC) and the adequacy of the intelligence documents themselves. From the establishment of the AAFSAT library in March 1943 to the end of the year, the information needs of the tactical center became fairly well defined by the demands made upon the library during that time and by the opportunities for service which had arisen.

16

The functions to be performed may be summarized as follows:

1. To facilitate research projects by experimental and testing agencies operating under the Army Air Forces Board.
2. To provide information for the Air Room.
3. To provide material for tactical and technical instruction at AAFSAT.
4. To act as an information center for tactical units attached to AAFSAT, and specifically to provide intelligence library facilities for the Demonstration Air Force.
5. To provide proper materials for the intelligence files at satellite fields.
6. To assist visiting research workers from other stations and commands.
7. To provide properly authorized individuals with information on specific topics pertaining to their military duties.
8. To maintain an active comparison of training literature with reports from theaters of operations and to provide new material for revision of training manuals and pamphlets.
9. To act as a clearing house for inquiries to be forwarded to the Liaison Officer in Washington.

-
15. Memo for Lt. Col. R. G. Storey by Lt. C. D. Chamberlin, 10 Nov. 1943. Copy in AFIRI files.
 16. Memo for Joseph Reither, AFIRI, by Lt. E. H. Benson, AAFAC, Dec. 1943, in AFIRI files.

~~RESTRICTED~~

- ~~RESTRICTED~~
~~SECURITY INFORMATION~~
10. To act as a distribution center for AFSAT intelligence publications.
 11. To prepare continuing bibliographies and check-lists for reference work in intelligence.
 12. To edit intelligence extracts and directs for distribution to the local command.
 13. To maintain files and indexes for all the purposes previously listed.
 14. To preserve intelligence materials suitable for inclusion in archives.

These functions were gradually clarified by demands for information from the various organizations and individuals of the tactical center. A list of typical sources of these demands will indicate the nature of the problem. The following list is typical, but not complete, and takes no account of requests for numerous individual documents or fragmentary information:¹⁷

AAF Board
 Air Room
 Air-Sea Rescue Section
 Antiaircraft Artillery
 Armament Section
 Chemical Warfare
 Combat Operations
 Communications, AFSAT, and Kent Unit
 Control
 Demonstration Air Force, A-2
 Ground Arms
 Intelligence Department, AFSAT
 Maintenance
 Night Fighters, Group S-2
 Night Bombardment Group
 Recognition Section
 Royal Air Force Office
 Tactical Air Force, A-2
 Weather Squadron

17. Ibid.

~~RESTRICTED~~
~~SECURITY INFORMATION~~

~~RESTRICTED~~
~~SECURITY INFORMATION~~

In addition to those demands made upon the intelligence collection by the tactical center itself, many other stations sought and obtained tactical information at the tactical center library. The following is a typical, though not a complete, list of stations which at the close of the year 1943 availed themselves of the resources of the intelligence library at MATIC:

AAC Intelligence School, Harrisburg
 Camp Hood
 Camp Lee
 Central Flying Training Command
 Command and General Staff School
 Droy Field
 First Bomber Command
 First Motion Picture Unit
 Fort Benning
 Fortune Magazine (unclassified information)
 Foster Field
 Fourth Air Force
 Hondo Navigation School
 MacDill Field
 Maxwell Field
 McLaughlin Field
 Netherlands East Indies Air Force, through AAF
 AAF Delegation
 Randolph Field
 Second Air Force
 Third Air Force
 Twentieth Bomber Command
 Wendover Field
 U. S. Military Academy
 U. S. Naval Station, Jacksonville

From March through June the number of reference requests handled by the library registered a fairly moderate growth. But during the course of the survey the requests increased tenfold. Circulation of intelligence items increased from 5,369 in April to 16,831 in June. From June to November 1943 there was a steady increase in circulation

~~RESTRICTED~~

~~SECURITY INFORMATION~~

~~RESTRICTED~~
~~SECURITY INFORMATION~~

73

of items to a total of 64,324 in the last-mentioned month. In September, due to the establishment of new staff and inspection courses at AASST, circulations temporarily jumped to 106,720, and it may be expected that similar variations in the steady growth of circulation will occur whenever special demands are made upon the tactical school.¹⁸

The statistical data just presented give a notion of the quantity and variety of demands for tactical and technical information confronted by the intelligence collection at AAFIC. By early 1944 the situation was very much improved over what it was in June 1943, but it was difficult to judge how much further improvement was practically possible. Since AAFIC had to rely upon Headquarters for much of the intelligence material upon which it depended, it was all too easy to assume that delays in forwarding intelligence reports were attributable to inefficiency or indifference on the part of Headquarters personnel.

It has already been pointed out that Headquarters in general consistently failed to appreciate the need of the tactical center for exact, current tactical information. But it is also a fact that in many cases Headquarters itself had been unable to obtain prompt forwarding of material from the theaters and other sources. British pamphlets, Intelligence Summaries, and Intelligence Bulletins all bore a date of issue. Frequently several issues under various dates were received at Headquarters in a batch. The same thing was true of Daily Intelligence Summaries and Abstracts as well as weekly reports from the Tenth and Fourteenth Air Forces. These usually arrived at Headquarters

18. Ibid.

~~RESTRICTED~~

~~RESTRICTED~~
~~SECURITY INFORMATION~~

in a batch covering two or three weeks' accumulation of reports. And it was likely that, given the conditions which inevitably prevailed in the theaters, it would not be possible to establish more frequent transmission of intelligence reports to Headquarters. 19

As has already been indicated, however, the amount of time consumed in forwarding tactical and technical information from a variety of sources to the tactical center was not the only difficulty confronted. The nature of the reports themselves and the information they contained often left much to be desired from the point of view of the personnel of the tactical center whose main interest was the tactical aspect of theater experience. One example of this is the mission report. These often contained a great deal of interesting information and gave a fairly complete picture of the conduct of the mission covered. This information was usually presented under such headings as the following: 20

- Start of the mission
- Briefing
- Flight to the target
- Interception encountered
- Fighter combat
- Bombing of the target
- AA Antiaircraft Artillery
- Weather
- Results of the mission
- Interrogation of flyers

However, in the great majority of such cases AFPTAC wanted to be told: Why was this target selected? How was the mission planned? By whom? Why 500 instead of 300 planes? What were the reasons for employing

19. Interview with Maj. Thompson Dean, AFPTAC Liaison Officer, AG/AS, Intelligence, 8 Feb. 1944, in AFTHI files.
 20. Ibid.

~~RESTRICTED~~
~~SECURITY INFORMATION~~

~~RESTRICTED~~

75

aircraft from widely scattered bases instead of drawing them all from the same region? Why 500-pound bombs instead of 1000-pound bombs? What formations were employed? In what positions in these formations are planes most vulnerable to enemy attack? This type of information has always been of interest from the point of view of tactical development. More recently it has become important in connection with the instructional functions of MFSAT.

There was difficulty in establishing definitely the informational requirements of the tactical center. And the determination of standards for reporting tactical information was important as a step in assuring the steady flow of essential information. The difficulties were increased by the fact that the functions, and consequently the intelligence needs of MFTIC, were subject to constant change. For example, during the first half of 1943 the School of Applied Tactics was engaged in training cadres. Its chief concern was to teach young flyers how to conduct themselves on the missions that would be assigned to them and how to encounter all the obstacles of antiaircraft, fighter opposition, weather, and a variety of other factors which might interfere with the performance of their assigned tasks. But during the summer of 1943, there began to arrive at MFSAT classes from the Army-Navy Staff College (ANSCOL). The members of these classes, who were being trained for combined operations, were very much interested in the planning aspect of missions and larger actions.

It was immediately apparent to the high-ranking officers of the ANSCOL classes that their instructors were not in possession of all

~~RESTRICTED~~~~RESTRICTED~~

~~RESTRICTED~~
~~SECURITY INFORMATION~~

76

21

the information necessary for higher staff instruction. Col. J. E. Smart, assistant on General Arnold's Advisory Council, was a member of the ANECOL elder attending courses at AFSAF in October 1943. Appreciating the difficulties of the situation, he left with the Intelligence Department of AFSAF valuable information and promised that he would take steps to see that information on a higher level would be made available to the tactical center.

In line with these efforts to obtain intelligence which had formerly not been made available to the tactical center, a letter was sent to OCAE on 31 August 1943 indicating a need for additional information on heavy bombardment missions. Finally, on 14 October 1943, a request was addressed to the Commanding General, Eighth Air Force, that in addition to the usual information contained in reports of bomber missions--routes, enemy air action, bombing, flak diagrams, weather, battle damage, statistical data--²² there be given the following information for the use of AFSAF:

1. Types of formation flown and evasive action used by the heavy bombardment units.
2. Types of formation, positions flown, and tactics used by escorting fighters.
3. Interrogation data and field orders or briefing data for escorting fighters.
4. Data on which the heavy bombardment mission was based or briefing notes for the mission.

The request was complied with. Beginning 17 November 1943, extra copies of reports on Eighth Air Force bombing missions for the use of

21. Interview with Col. Storey.
22. Col. Morris R. Nelson, Chief, Requirements Div., 10/15, OCAE, to CG, 8th AF, 1/ Oct. 1943. Copy in AFSAF files.

~~RESTRICTED~~
~~SECURITY INFORMATION~~

77

AIRMG contained the desired information.

It is understandable that theater personnel did not have time to analyze every combat problem to the full satisfaction of each and every expert in the War Department at home. Their irritation with demands for detailed reporting of theater activities was natural. Similarly, the exasperation felt by many a technical expert at home at his inability to obtain essential information from the theaters was comprehensible and, to an extent, justifiable. But under the pressures and ever-changing conditions of warfare, it was unlikely that it would ever be possible to establish anything like perfect liaison between component parts of the different branches of the service. Frictions had to be established for information as well as for material and personnel.

Perhaps a final example will serve to illustrate the shifting nature of the considerations which governed the routing of intelligence. When the first 13 YF-40s were shipped to the Eighth Air Force in the spring of 1943, the personnel of the tactical center who had recommended a number of modifications in the plane were naturally interested in knowing to what extent theater experience confirmed their judgment of the capabilities and defects of the plane. Such information would have great value in the development of a completely new fighter-destroyer project. But it was known in the theater at the time that the development of long-range fighter escort planes was well under way and that these would before long replace the YF-40s. It was also realized that any considerable production of fighter-destroyer planes

~~RESTRICTED~~
~~SECURITY INFORMATION~~

~~SECRET~~

would interfere with bomber production, and the theaters were anxious to receive as many heavy bombers as could be provided at as early a date as possible. Ultimately, the original thirteen XB-40's were modified, but no detailed report on their performance was submitted to Headquarters or to the tactical center. Since the production of XB-40's was abandoned, it might easily be argued that a final report from the theater on their performance would be of little value except as a final footnote for the historical record. However, flak damage to airplane motors later made necessary the consideration of armor protection. It was realized that a report on the armor protection of the XB-40's would be of value in devising armor protection for various types of planes and motors. As a result it was necessary to cable the Eighth Air Force requesting an investigation and report on the armor of the XB-40.²³ Ideally, it would have been convenient to have this information on file in a report on the XB-40. Practically, such information could only be insisted upon when its primary importance was established.

However, the difficulty of obtaining needed tactical information from the theaters was only one aspect of a many-sided problem. Headquarters continued to manifest a very conservative attitude with respect to the release of intelligence to the tactical center. Despite the improvements that had been brought about in this situation, there were indications that APTAC would continue to meet resistance to its

23. Interview with Capt. C. E. Michohl, Requirements Div., 16/12, OMR, 15 Feb. 1944, and Daily Diary, Requirements Div., 16/13, OMR, 4 Feb. 1944, Item 2, in APTAC files.

~~RESTRICTED~~

79

~~SECURITY INFORMATION~~

demands for highly classified information. In April 1942 there developed a need for certain specific information to be used in the instruction of senior officers and of classes in combined operations of the Army-Navy Staff College. A request was made for statistical data showing the total tonnage that had been ferried "over the hump" by the Air Transport Command, the monthly tonnage ferried by LIC to China, and the percentage of tonnage delivered to Chinese and U. S. Army units respectively. The request met with 100 per cent non-concurrence from CG/AS, Plans, CG/AS Intelligence, the Deputy Chief of the Air Staff, and Management Control.

With respect to the inadequacy of theater intelligence, Headquarters was in part responsible for not providing for the proper qualification of intelligence officers. This fact was most strikingly apparent to observers in the field who were given an opportunity to contrast American intelligence officers with combat units with the British. Unfortunately, much of the criticism of this situation was by word of mouth as was the case with Headquarters discussions of the problem. However, in one case comments of Lt. Col. Palmer Dixon are recorded in an interview and later embodied in a memorandum to General Craig. Colonel Dixon noted the need for additional training of intelligence officers destined for foreign theaters. He asserted that their ignorance of tactical and strategic problems in general and their failure to make a proper study of the particular

2/. REF, CG/AS, OOR (AF Board Control Office) to (1) CG/AS Plans, (2) CG/AS Intelligence, (3) Secretary of Air Staff (Attn: Lt. Col. R. H. Harper,) (4) correspondence in AFHQ files.

~~RESTRICTED~~

~~RESTRICTED~~
~~SECURITY INFORMATION~~

tactical and strategic problems of the theater to which they were assigned impaired their efficiency both in rendering guidance to the flyers themselves and in making discriminating use of the information which came to their notice for digest and report to Headquarters. He developed these views as follows:

In order to turn the information that we get from these intercept units into useful Intelligence we have to have Intelligence officers trained in correlating the various items of interception. We are at present dependent on the RIF for such officers....

There aren't in our Headquarters, American officers who have been specially trained. The British have had three years to train their officers in these particular specialty phases, and we have not had any such time. We need several more specially picked officers to complete the U.S. representation in the U.S.C. Intelligence....

Question. To what extent do the A-2's and Intelligence officers of higher echelons go on missions; accompany missions over enemy territory?

Answer. Not much, sir. As a matter of fact, I would say General Doolittle and General Spartz and some of the higher people who shouldn't be doing it are going on many more missions than some of the S-3's. Colonel Young, the A-2 for the Strategic Air Force, has been on at least half a dozen, but I would say by and large that they mostly stay home. They have a lot of other duties, such as censorship, counter-intelligence, and various other things that keep the average officer pretty close to the ground.

The gathering and dissemination of tactical intelligence is one of those problems which can never be solved to everyone's satisfaction. The time factor involved in securing and transmitting intelligence is always subject to criticism. The nature of the intelligence itself is something that can never be definitely established, for the tactical situation in the theater is undergoing constant change, and the requirements and problems of the tactical center shift from month to

25. Digest of Interview with Lt. Col. Palmer Dixon, 10 June 1942, in AFHQ files.

~~RESTRICTED~~
~~SECURITY INFORMATION~~

~~RESTRICTED~~
~~SECURITY INFORMATION~~

81

month. Discrimination must be used in selecting tactical data for forwarding to Headquarters and thence to the tactical center. Were every item which might have some tactical value carefully noted down and reported, the whole intelligence system would bog down. Yet, an item of tactical intelligence which it seems perfectly safe to ignore today may prove to be of crucial significance a month hence.

These unsatisfactory basic factors cannot be altered. But effort can and should be constantly directed toward securing a clear definition of the informational needs to be satisfied as quickly as possible and to facilitating and speeding the transmission of intelligence by maintenance of the most perfect liaison possible among the offices and agencies controlling intelligence functions.

Dissemination of Tactics

By early 1944 the general procedure in tactical development was about as follows: When a tactical need had been recognized, when the problem had been broken down into its components and material changes had been made where needed, when the tactical center had developed the tactical solution which it was convinced would meet the demands of the situation, the AEF Board then submitted a full report of its findings and recommendations to OCSB. As a rule, six copies of the report were submitted in order to facilitate review by different officers. Copies of the report were then submitted to Headquarters experts who reviewed the recommendations in the light of a multitude of considerations.

~~RESTRICTED~~
~~SECURITY INFORMATION~~

~~RESTRICTED~~
~~SECURITY INFORMATION~~

82

Conditions, equipment, and techniques of combat differed in the various theaters of operations, and it was necessary to decide whether the recommendations of the tactical center could be applicable in all cases. If important modification of planes or equipment were involved, it became necessary to decide whether these changes could be undertaken without disrupting schedules of production or of shipments to the theaters. When all aspects of the problem had been reviewed by qualified officers and their opinions had been recorded, objections or criticisms noted and discussed, a decision was reached as to whether and in what manner the recommendations would be communicated to the theaters.

The application of a new tactic occurred in a variety of ways. Usually the tactical procedure was recommended to the theaters concerned by OCSB, and the theaters then often conducted their own tests to decide to what extent the recommendations would be adopted. With few exceptions, theater experience fully confirmed the value of the recommendations made by the tactical center through the AF Board. Meanwhile, the School of Applied Tactics would have embodied instruction in the new tactics in its program of instruction to cadres. In cases where training procedures in the domestic training centers were affected, a training standard was produced as a means of disseminating the new tactic. Although a number of Headquarters officers were concerned with the establishment of Training Standards, the AF Board assumed primary responsibility for preparing Training Standards for new types of tactical units and with the development and maintenance of up-to-date Training Standards for all established types of AF tactical units. ²⁶

26. AF Reg. 5-20, 30 Dec. 1943.

~~RESTRICTED~~

In forwarding the recommendations of the tactical center to the Air Forces in the theaters of operations, there are two considerations of basic importance. The recommendations must be presented in a manner which will insure that they are read, understood, and adopted. Clarity in presentation is a prime requisite. Attention was given to this factor when the recommendations were drawn up by the AIF Board, and it was kept in mind by the tactical and technical experts in OADR whose responsibility it was to review the recommendations of the board. An example has already been cited of the care given to the presentation of tactical recommendations. The tactical suitability trials of the F-47C were the first in which the new tactical center was called upon to make a complete study of the tactical employment of a new plane. In this instance, the reports of the RIF Development Unit were adopted as a model, and the assistance of an RIF officer was obtained in the preparation of the first report.³⁷

The second consideration is the time factor. It is necessary that tactical solutions to combat problems be placed in the hands of the fighting men as quickly as possible. At the same time, it is of utmost importance that tactical recommendations be fully reviewed and checked before they are passed on to the theaters. A proper balance of emphasis must be maintained in reviewing and dispatching recommendations to the theaters. Too much haste in passing on recommendations without giving proper consideration to all the factors involved could result in inappropriate action and a discrediting of the tactical

37. See Chap. II, The Development of Tactics.

~~RESTRICTED~~~~RESTRICTED INFORMATION~~

~~RESTRICTED~~~~SECURITY~~

development agencies in the eyes of theater personnel. On the other hand, overcaution or a failure to appreciate the importance of prompt action would deprive the fighting man of one of his means of performing their missions effectively.

A study of all projects completed at AFSAF from the time of its establishment to 15 August 1943 reveals that the average time elapsed between the date of the submission of the report and final action by CGAR was six to seven weeks. In a very few cases only, the time-lag was nearer six months.²⁸ Even had there been a disposition on the part of review officers to overlook the importance of the time element in approving or disapproving tactical recommendations, there was little likelihood that they could forget it for long. The close personal liaison maintained between the tactical center and headquarters provided many opportunities for the personnel of the tactical center to demand by so much time as required to approve its recommendations. And these opportunities were not neglected.

The danger was acutely appreciated in other quarters. The office of CGAR was constantly under the scrutiny of Management Control. On 27 September 1943 a study called attention to the fact that review procedures "if improperly conducted, may result in administrative bottle-necking and even in 'back room' erosion of Board recommendations." It was considered essential that a representative or deputy of the AF Board "be given authority to compel prompt and incisive consideration of all AF Board matters to the end that the constructive work done at Orlando not be lost in the Washington paper mill."²⁹

28. Study by Service Section, AFHQ-11, in AFHQ files.

29. Memo for 16/13, CGAR by Management Control, copy unsigned, 27, 27 Oct. 1943, in AFHQ files.

~~RESTRICTED~~
~~SECURITY~~

The matter already established in COMAF a liaison officer for AEFMC (later AEFMC). This officer's time was fully occupied, however, with business growing out of projects currently under development by the tactical center. It was not possible for him to devote any considerable amount of his time to following up requisite action on the projects that had been turned over to the AEF Board and which had been sent to COMAF in the form of recommendations by the Board. The appointment of a special liaison officer in the office of the AG/AS, Intelligence had greatly facilitated the transmission of intelligence to the tactical center, and it seemed likely that a similar arrangement would result in speeding the dispatch of the board's business with the office of the AG/AS, COMAF. Col. Raleigh H. Packlin was selected to represent the AEF Board at Headquarters. On 13 December 1943 an Office Memorandum announced the establishment of an Army Air Forces Board Control Office in COMAF.³⁰ The same memorandum established procedures for liaison with the board and for the processing of board reports. There was every indication that through this liaison office procedural difficulties and delays would be reduced to a minimum.

The embodiment of new tactics in the curriculum at AEFMC as a means of imparting the latest tactics to the cadets sent there for tactical instruction requires no more than a brief comment here. It is fundamentally a training problem and as such has no place in this study. However, the establishment of training standards affecting tactical training is a

30. Office Memorandum for all divisions and branches, COMAF, by Col. Raleigh H. Packlin, Deputy AG/AS, COMAF, 13 Dec. 1943.

~~SECRET~~

Headquarters function which is fundamental to the dissemination of tactical doctrine and procedures, and consequently warrants consideration here. Theoretically the Requirements Division of OOR established a requirement for a new Training Standard or for the revision of an old one, and the Training Standard was then drawn up by the AIF Board and submitted to OOR for review, approval, and issuance. Actually, the procedures leading to the initiation of a Training Standard were always highly informal.

It has been observed that practically every item of material and personnel has a tactical aspect--the aspect which involves its military employment. Consequently every change in material or organization potentially involves training procedures. When a particular type of foot car is made standard in the AIF it is obviously unnecessary to issue a Training Standard to explain its use. But a more complicated item of equipment is likely to require the establishment of standards for its correct employment. In February 1944, when a change of procedure, or material, or organization, was likely to involve questions of correct application, the officer most directly concerned with the establishment of the new requirement in the Requirements Division of OOR would probably raise the question of a need for a change in Training Standards. Informally the matter would be laid before interested personnel in the office of the AG/AS, Training. It was likely that the Air Inspector could be consulted. Often the AIF Board would be asked whether a need for the revision of a Training Standard or the issuance of a new one was acknowledged. In this informal manner, decisions were arrived at quickly and the board was asked to draw up a Training

~~SECRET~~

~~RESTRICTED~~
~~SECURITY INFORMATION~~

Standard.

The chief problem arising in connection with the tactical aspects of training resulted from the multiplicity of procedures. The situation was the occasion of a letter addressed to the Commanding General by the Executive Director of the IAF Board on 30 October 1943. In it General Eubank called attention to the fact that:

Recent observations of operations in the continental United States of Air Force and Combined Arms maneuvers, in cooperation with the Third Air Force, relative to Tactical Air Force organization and operation, and the training of Aircraft Landing and Fighter Control units, bring to light the following conditions:

a. Widely divergent operating procedures in the Fixed Air Defense operations of the First, Third and Fourth Air Forces.

b. Separate, duplicate and widely divergent plans, organization and procedures in Combined Mobile Air Defense maneuvers, which is, in fact, training for Tactical Air Force operations. A large part of this work is a duplication of the work already completed by the Army Air Forces Board and approved by Headquarters, Army Air Forces.

c. A lack of information on the part of the new commanders and their Staffs relative to the basic organization and procedures for Fixed Air Defense. Therefore, these new commanders and staffs are duplicating the basic studies of organization and procedure for Air Defense (Fixed) due to lack of sufficient directives for the employment of approved doctrine.

General Eubank reminded the Commanding General that "The basic principles, tactics and techniques recommended by the Army Air Forces Board for the above operations are those now being employed in the combat theaters in whole or in part. Therefore, to efficiently conduct OTU and LFW training, the above procedures should be standard

31. Orig. Gen. E. L. Eubank, Executive Director, IAF Board, to CG, IAF, 30 Oct. 1943. Copy in AFHQ files.

~~RESTRICTED~~

~~RESTRICTED~~
~~SECURITY INFORMATION~~

in the various training elements of the Army Air Forces." ³² The procedures referred to were contained in manuals and projects listed in three appendices to the letter.

Aids from the multiplicity of procedures involved, part of the difficulty described by General Dufank was a consequence of the multiplicity of factors affecting training. Pilots and their instructors were equally anxious to pick up the latest "dope" on tactics employed in the theaters. In general, however, they were not in a position to acquaint themselves with all the factors which must be considered before a tactical procedure is adopted. At the tactical center it was observed "that many training centers and units have eagerly sought out any bit of intelligence for training, however obsolete the information. Preventing the dissemination of dead or dangerously misleading intelligence is of primary importance." ³³

By early 1944, many flyers with theater experience had been returned to the United States to train the pilots with which they would return to various theaters of operations as squadron leaders or in other positions of command. In most cases, the experience of the individuals was limited to a single theater and often to a particular type operation. Their youth and limited experience did not enable them to perceive readily that their experiences would not be applicable to situations arising in far distant theaters of operations. They were all too easily disposed to

32. Ibid.

33. Memo for Joseph Feithar, AWHI, by Lt. H. E. Hanson, AWHI, Dec. 1943, in AWHI files.

~~RESTRICTED~~
~~SECURITY INFORMATION~~

~~RESTRICTED~~
~~SECRET~~

regard as armchair theorists the instructors whose responsibility it was to impart tactical procedures and doctrine. And their youthful associates could not help but be influenced by the views of these young veterans.

Also theater personnel were constantly returned to the United States and time available for discussions of their combat experience. Late in 1943 a party of eight officers under Brig. Gen. Curtis LeMay, Commanding General, 3rd Bombardment Division (H), Eighth Air Force, was conducted on a tour of some seven training centers where they addressed groups of students and instructors on the tactics of combat employed in the Eighth Air Force. ³⁴ While the value of this sort of liaison with the theaters is obvious, it should be apparent that students would not always realize that the experience of even a group of officers from an important theater would not cover the whole tactical field.

In summary, the dissemination of tactics occurred through direct recommendations to the commanders of the air forces in the theaters of operations and through training. In the first instance, the chief problems encountered were that tactical recommendations be adequately and clearly presented and that they be placed in the hands of the men in the theaters with as little delay as possible. In the second, the situation is less clear. It is observable, however, that early in 1944 there was still a need for standardizing the tactical aspects of training and for protecting instructors and flyers against the criticism

34. Itinerary and personnel lists covering trip of Brig. Gen. Curtis LeMay and party, 2 Dec. 1943. Copy in FHM files.

~~RESTRICTED~~
~~SECURITY INFORMATION~~

of partial, obsolete, or misleading tactical information. In the first case, a practical solution seemed to have been found for the difficulties inherent in the situation. In the second instance, much remained to be done.

~~RESTRICTED~~
~~SECURITY INFORMATION~~

~~RESTRICTED~~
~~SECURITY INFORMATION~~

Chapter IV

CONCLUSIONS

SA
The only sound approach to any general appraisal of the work of tactical development in the Army Air Forces is the historical one--that is, judgment must be based upon the actual situation as it was confronted and dealt with from day to day rather than upon any theoretical scheme of tactical development. For a whole year after the United States was actively at war with the Axis powers, it was not possible to establish a center organized for tactical development and training for two principal reasons: (1) it was necessary first of all to turn out planes and men who had been taught to fly them, before attention could be given to tactical training, and (2) it was vital that the limited number of experienced personnel available be assigned to other tasks. In the meantime, such opportunities as presented themselves for the development and test of new tactics had to be met practically and to be dealt with by whatever existing agencies were best fitted to carry on the work.

When the tactical center was set up in Orlando in November 1942 it was called the Army Air Forces School of Applied Tactics (AAFSAT), thus giving emphasis to the fact that it had been established to give training in tactics to cadres selected from units being prepared for combat. At the same time AAFSAT took over the development work in

~~RESTRICTED~~
~~SECURITY INFORMATION~~
91

~~RESTRICTED~~
~~SECRET~~

tactics which was then being carried on largely by the Air Defense Board and the Fighter Command School at Orlando. Time was required in which to establish curricula and to develop facilities and organization. A certain amount of time and experience was necessary before it was possible to establish definitely just what the needs of the tactical center would be and in what manner it would have to rely upon the services of Headquarters in the matter of tactical intelligence and in the establishment of procedures for the assignment and conduct of tactical test and development.

As the needs of the tactical center became clarified, necessary personnel was secured, facilities were expanded, the curricula of the tactical school were revised, teaching methods were studied and perfected. In a similar fashion, the conduct of tactical development and testing resulted in expansion of facilities and in the development of valuable liaison with experts within and without the Army Air Forces whose knowledge and experience could be drawn upon in connection with tactical development.¹ Careful studies of the informational needs developed in connection with both tactical instruction and tactical development were submitted to the AC/AS, Intelligence; these resulted in the establishment of an AAFSAT representative in the office of the

1. Note comments on AAF Board Project (T-5) 13, Chap. II.

~~RESTRICTED~~
~~SECRET~~

~~RESTRICTED~~
~~SECURITY INFORMATION~~

93

AC/AS, Intelligence whose function it was to accelerate the dispatching of tactical intelligence to the center and to make known to the AC/AS, Intelligence the informational needs of AAFSAT.

In November 1943, the tactical center was reorganized and redesignated the Army Air Forces Tactical Center (AAFTAC), thus giving proper recognition to its dual function which included a greatly extended program of tactical development and test.

In line with the general effort to decentralize as many functions as possible, the Army Air Forces Board was created on 12 November 1942 to take over the detailed assignment of tactical development and test, and to coordinate the work of the tactical center and the Proving Ground Command in this work. The board also assumed responsibility for the issuance and revision of Training Standards as they affected tactical instruction. As difficulties arose, particularly in connection with the time involved in securing review and final approval of AAF Board recommendations and in the maintenance of training procedures in line with tactical Training Standards, it was decided to adopt a solution similar to the one which had resulted in the improvement of Headquarters' intelligence services to the tactical center. A Deputy Assistant for the AAF Board was established in OC&R.

What has been described in this study is a gradual redefinition

~~RESTRICTED~~
~~SECURITY INFORMATION~~

~~RESTRICTED~~

94

~~SECURITY INFORMATION~~

and reintegration of tactical developmental processes in the Army Air Forces after an initial dispersal--resulting momentarily in almost complete neglect--that was made mandatory by the sudden demand to create a super-air force practically overnight. As a result of this calculated neglect, the gradual re-establishment of developmental processes and agencies encountered some psychological obstacles which must not be overlooked in any appraisal of the problem. In the first place, tactics are intangible and are therefore, in a sense, nonexistent except insofar as they are actively understood and applied. Since, to the average person, the tactical aspect of a situation is usually the most difficult to perceive, there is a general tendency to ignore it or to underestimate its importance.

Furthermore, the problem of correct techniques of employment of modern mechanisms is one to which the average American has never had to give much attention. Each new gadget that is made available to him in civilian life is simpler to operate than the one that went before. Tuning-in a station on an old-fashioned radio was often a delicate operation. However, as radio receiving sets grew more complicated in mechanism it became possible to tune in a station merely by pressing a button. But the simple act of putting a domestic machine in operation is in no way comparable to the elaborate technique often involved in the correct employment of complicated instruments of warfare. The skill and precision which must be developed in the

~~RESTRICTED~~~~SECURITY INFORMATION~~

~~RESTRICTED~~
~~SECURITY INFORMATION~~

95

latter case are more akin to the expert practice which enables a physician to wield his knife in removing a malignant growth without endangering the life of the patient.

As a result of these factors, the tactical center was sometimes the subject of unintelligent criticism. Its tangible aspects were an extensive plant equipped with expensive installations and a demonstration air force of considerable size. These were occasionally the subject of unfavorable comment on the part of persons who little understood either the needs or the services of the tactical center. It is perhaps inevitable that among the many components of a huge military organization hastily drawn together there would be little time to appreciate either the importance or the difficulties of the other fellow's job. And since the "gripe" is traditional in the American military service, little restraint is exercised in the expression of unfavorable opinions. As time passes and the relationships between Headquarters and the developmental agencies operating under the direction and coordinating influence of the AAF Board become further defined and established, these factors will become of minor importance.

Experience would seem to indicate that during the course of a war which is being fought in every area of the globe, there is a definite limit to the extent to which responsibilities for tactical development and the dissemination of tactical information can be decentralized.

~~RESTRICTED~~
~~SECURITY INFORMATION~~

~~RESTRICTED~~
~~SECURITY INFORMATION~~

96

Lacking the corrective of definite past experience with a similarly functioning organization, it would seem likely that when peace is once again established it should be possible for the AAF Board to assume full and comprehensive responsibility for both the development of new tactics and for the dissemination of tactics and the maintenance of tactical standards in training and in operations. But in the situation which actually confronted the Army Air Forces in early 1944, several obstacles prevented the realization of this ideal. Tactics originate and have their ultimate application and test in combat operations. But as has been indicated, due to the highly technical character of modern warfare tactical problems usually have nontactical aspects which must be dealt with by other than tactical agencies. The separation and assignment of the separate projects growing out of a tactical situation must pass under the review of Headquarters. In addition, military plans and the pressure of other considerations occasionally necessitate at least the temporary sacrifice of tactical developments which are in themselves logical and even inevitable.² It is necessary that decisions in such instances be arrived at and coordinated at Headquarters, and finally, the concentration of intelligence at Headquarters makes necessary either the dependence of the tactical center upon Headquarters intelligence, or

2. For example, the Headquarters decision not to modify the YB-40; see Chap. II.

~~RESTRICTED~~
~~SECURITY INFORMATION~~

~~RESTRICTED~~

97

alternatively, the establishment of a wasteful duplication of intelligence services.

In February 1944, the services performed by the tactical center in tactical development were equivalent to those performed jointly by the Materiel Center and the aircraft production plants. Neither of these agencies was able to establish military requirements with respect to airplanes or other items of materiel, although either or both might produce a plane or item of equipment for which it might be discovered that a military requirement existed but had not been formulated. Consequently Headquarters, which was able to weigh every related fact, including future plans, training and production schedules, and tactical considerations, determined requirements and assigned developmental projects accordingly. The development of tactics was handled fundamentally in much the same way. Tactical needs along with suggestions or indications of possible solutions were communicated to Headquarters where every consideration affecting the situation was taken into account and coordinated. Finally, the problem was analyzed and was assigned in the form of projects which might involve tactics, materiel, organization, equipment, or other factors. The time element was an important consideration, and only at Headquarters was it possible to effect the necessary initial coordination of all relevant factors by immediate personal contact in a minimum of time.

When the urgent pressure of a changing war situation is removed,

~~RESTRICTED~~~~CONFIDENTIAL~~

~~RESTRICTED~~
~~SECURITY INFORMATION~~

it is possible that these functions may be efficiently performed by some board or agency detached from Headquarters. Until that time, it is probable that Headquarters will have to function actively and extensively in tactical development. The weaknesses inherent in this situation have been pointed out. They are the consequence of organizational tenuousness and they result in critical delays in assigning projects, in transmitting essential information, and in taking prompt final action upon tactical recommendations. In addition, a number of psychological factors tend to distort perspectives and heighten tension. Nevertheless, a frequent review of the situation with an alert eye to its inherent weaknesses should make possible the maintenance of effective development of tactics and their prompt dissemination under the changing conditions of the present war.

~~RESTRICTED~~
~~SECURITY INFORMATION~~

~~RESTRICTED~~

~~SECURITY INFORMATION~~

GLOSSARY OF ABBREVIATIONS

AAF	Army Air Forces
AAFSAT	Army Air Forces School of Applied Tactics
AAFTAC	Army Air Forces Tactical Center
AAG	Air Adjutant General
AC	Air Corps
AC/AS	Assistant Chief of Air Staff
AFIHI	Assistant Chief of Air Staff, Intelligence, Historical Division
AFIHI-AH	Assistant Chief of Air Staff, Intelligence, Historical Division, Administrative History Branch
ANSCOL	Army-Navy Staff College
AR	Army Regulation
G/AC	Chief of the Air Corps
C/AS	Chief of Air Staff
Comdt.	Commandant
Dir.	Director or Directorate
FM	Field Manual
GO	General Order
Hq. O. I.	Headquarters Office Instruction
M.A.C.	Mediterranean Allied Command
NDRC	National Defense Research Council
OCAC	Office of the Chief of the Air Corps
OC&R	Operations, Commitments, and Requirements
R&R	Routing and Record Sheet
WD	War Department

~~RESTRICTED~~
~~SECURITY INFORMATION~~

~~RESTRICTED~~
~~SECRET~~

BIBLIOGRAPHY

Official Publications

War Department

- Adjutant General Letters
- Army Regulations
- General Orders
- Manuals
- Memorandums

Army Air Forces

- Board Reports. These include Project Reports and Monthly Status Reports.
- Headquarters Office Instructions
- Letters
- Memorandums
- Regulations
- Organization Charts
- AAFSAT Air Room Interviews
- AAFSAT Intelligence Reports

Files

AAF Cables

AAF Central Files (Unclassified)

- 320. Misc. Orlando, Florida
- 321. Organization
- 321.9 Maxwell Field, Misc.
- 352. School of Applied Tactics
- 352.9 Tactical School

AAF Office Files

- AAF Board--files of development sections
- AAFTAC--Intelligence files; Historical Section files
- AC/AS, Intelligence--file of AAFTAC Liaison Officer
- AC/AS, OCS&T, Requirements Division--files of Project Officers; files of Liaison Office

~~RESTRICTED~~
~~SECRET~~
100

~~RESTRICTED~~
~~SECURITY INFORMATION~~

Interviews*

- Col. Joseph D. Lee, Jr., Executive Officer, AAF Board
- Lt. Col. Walter E. Lotz, Jr., Chief, Headquarters Division, Communications Department, AAFSAT
- Col. H. G. Montgomery, Jr., Chief, Tactics Division, AAF Board
- Capt. C. C. Robinson, Special Projects Officer, AAFSAT
- Col. J. E. Smart, Member Advisory Council to Commanding General, AAF
- Lt. Col. Charles W. Stark, Chief, Fighter Branch, Aircraft Division, AAF Board
- Lt. Col. Robert G. Storey, Chief, Intelligence Department, AAFSAT

*The above are signed interviews, in most cases based upon a series of discussions.

- Lt. M. J. Dauer, Operations Officer and Instructor, Army-Navy Staff Officers' Course, Air Support Department, AAFSAT
- Maj. Thompson Dean, AC/AS, Intelligence, Liaison Officer for AAFTAC
- Lt. Col. R. E. S. Deichler, Chief, Organizational Planning Division, Management Control
- Maj. R. A. Fisher, AC/AS, OC&R, Liaison Officer for AAFTAC
- Maj. J. S. Kaufman, Chief, Training & Operations Branch, Management Control
- Col. R. H. Packlin, Chief, AAF Board Control Office

*No signed report was obtained for the preceding six interviews. However, in most cases the individual interviewed supplied documentary support for important statements made during the course of the interview, and the documents have been cited in the text rather than the interviews.

Special Studies and Reports

- Annual Reports of the Chief of the Air Corps
- Baker Board Report. Final Report of the War Department Special Committee on Army Air Corps, July 19, 1934
- Biennial Report, Army Air Forces, 1941-1943, prepared by Historical Division, AC/AS, Intelligence
- Bradley Committee (Report on Organization of AAF in North Africa)
- History of the Air Defense Board

Records in Historical Division

- Cables--between Headquarters and theaters of operations, June 1942 to March 1944 inclusive

~~RESTRICTED~~
~~SECURITY INFORMATION~~

~~RESTRICTED~~
~~SECURITY INFORMATION~~

Historical Section, AAFAC, files

Interviews

Miscellaneous letters and documents--in most instances copies of letters and documents the originals of which are in office files in Headquarters, Washington, AAFAC, or the developmental sections of the AAF Board.

Unit Histories

~~RESTRICTED~~
~~SECURITY INFORMATION~~

~~RESTRICTED~~
SECURITY INFORMATION

I N D E X

A

A-2, 9. See also Intelligence.
 A-3, 9. See also Training.
 AAF Board, 11, 13, 17, 28, 30-32, 35, 43, 45, 48, 58, 69-70, 81-87, 93, 95-96
 Control Office, 59, 85
 Reports, 39-40, 42-43, 45, 50-52, 56-57
 AAF Equipment Board, 30
 AAF School of Applied Tactics. See Schools.
 AAF Tactical Center, 1, 22, 33, 35-36, 43, 45, 58-60, 70-75, 79-85, 93-98. See also Schools.
 Adjutant General, Office of The, 6 n
 Airborne fighter control squadron, 56
 Air Corps Board, 8, 29, 60-63
 Aircraft Warning Division, 14
 Aircraft warning service, 13-14, 40-42, 52-57, 59, 87
 Types of equipment, 56-57
 Air Defense, Directorate of, 10, 13-14, 24-25, 41-42, 54
 Air Defense Board, 11, 14, 27, 29-30, 41, 52, 55, 57, 91
 Air defense (fixed), 87
 Airdrome Defense Section, AA and Airdrome Defense Div., 14
 Air Forces:
 1st, 87
 3d, 87
 4th, 87
 5th, 37
 8th, 47-49, 78, 89
 9th, 37-38
 11th, 37
 Strategic, 80; creation of, 4-5
 Tactical, 87; development of, 4-5, 54
 Air Inspector, 86
 Air power, employment of, 5, 43

Air Section, Dir. of Ground Support, 11
 Air Service, 6, 61-62
 Board, 61-62
 Air Staff, 8-9, 17
 Air Support, 15-16, 25. See also Ground Support.
 Air War Plans office, 9
 Alaskan theater, 37
 Amphibious operations, 43
 Anti-Aircraft and Airdrome Defense Division, 14
 Appold, Maj. Norman C., 38
 Armored Force Branch, Dir. of Ground Support, 11
 Armor protection, 78
 Army-Navy Staff College (ANSCOL), 75-76, 79
 Arnold, Gen H. H., 40, 51. See also Commanding General, AAF.
 Advisory Council, 38, 76
 Asheville, N. C., 56

B

B-17 aircraft, 46-49
 Baker Board, 62-63
 Barr, Col. Percy H., 4, 67
 Base Services, Directorate of, 10
 Belmar, Fla., 54
 Bismarck Sea, Battle of, 37
 Bolling Field, D. C., 16
 Bombardment, Directorate of, 10, 15, 25, 27-28, 37

C

Campbell-Orde, W/C I., 51
 Cavalry Branch, Dir. of Ground Support, 11
 Civil Air Patrol, 16
 Civil Aviation and Traffic Control, Directorate of, 10

RESTRICTED

~~SECRET~~

Chamberlin, Lt. Charles D., 67
 Chief of Air Staff, 24
 Cody, Col. Thomas J., 42 n
 Cold Weather Testing Detachment,
 16, 18
 Combat Branch, Dir. of Ground Sup-
 port, 11
 Combat Division, Dir. of Ground
 Support, 16
 Commanding General, AAF, 13, 28,
 87. See also Arnold, Gen. H. H.
 Commands, 17
 1st Fighter, 39
 2d Interceptor, 26 n
 5th Interceptor, 25, 26 n, 65.
See also Schools, Interceptor
 Command.
 Air Force Combat, 19
 Air Service, 15
 Air Transport, 79
 Fighter, 13-14
 Materiel, 10-11, 15, 28, 58
 Proving Ground, 9, 11, 16, 18, 28,
 31-33, 37, 44, 49, 58-59, 93
 Communications, 19, 54, 56
 Directorate of, 10
 Division, Dir. of Ground Sup-
 port, 16
 Section, Fighter Div., 14
 Craig, Gen., 79
 Current Operations Section, Fight-
 er Div., 10

D

Dean, Maj. Thompson, 69
 Demonstration air force, 70; crea-
 tion of, 7, 27
 Deputy Chief of Air Staff, 79
 Development Section, Fighter
 Div., 10
 Directorates, establishment of, 9
 Dixon, Lt. Col. Palmer, 79
 Doolittle, Gen. J. H., 80
 Dorf, L. A., 42 n, 55

E

8th Bombardment Group, 48

81st Fighter Squadron, 50
 Eglin Field, Fla., 29, 39. See
also Commands, Proving Ground.
 Eubank, Brig. Gen. E. L., 28, 33,
 87-88

F

50th Fighter Group, 26, 50
 Fairchild, Maj. Gen. Muir S., 24, 39
 Field Artillery Branch, Dir. of
 Ground Support, 11
 Field Inspection Section, Dir. of
 Air Defense, 13
 Fighter control units, 87
 Fighter Division, Dir. of Air De-
 fense, 10, 14
 Foreign Trends Unit, Intelligence, 8

G

General Staff, WD, 9
 Operations Division, 14
 Gibson, Lt. Col. Kenneth H., 46
 Great Britain, Intelligence, 79-
 80; pamphlets, 73
 Ground Support, Directorate of, 10-
 11. See also Air Support and di-
 visions.
 Section, 11

H

Holland, Col. Harvey H., 23-24
 Hopkins, Lt. Col. J. G., 23
 Huff, Col. Sargent Prentiss, 37

I, J

Individual Training, Directorate of,
 10, 23-24, 65
 Infantry Board, 30
 Infantry Branch, Dir. of Ground Sup-
 port, 11
 Informational Division, AC/AS, Intel-
 ligence, 60
 Tactical and Technical Br., 60, 68

~~SECRET~~

~~RESTRICTED~~

~~RESTRICTED~~
~~SECURITY INFORMATION~~

105

Intelligence, 3, 15, 42, 60-90,
92-93, 96-97; (Section 2), 8
AC/AS, 24, 60, 63, 66-67, 79,
92-93
AAFSAT Liaison Officer, 70,
85, 92-93
Japanese fortifications, 43

91st Service Group, 26
Naples, 38
National Defense Research Council
(NDRC), 55-56
North African theater, 40, 44, 52-56

O

I
Langley Field, Va., 6
Lee, Col. Joseph D., Jr., 42 n,
50, 55
LeMay, Brig. Gen. Curtis, 89
Liaison and Intelligence Divi-
sion, 15
Lotz, Col. W. E., 55-56

Observation Branch, Dir. of Ground
Support, 11; Division, 16
Operational Analyst, Dir. of Air De-
fense, 14
Operations, Commitments, and Re-
quirements, AC/AS, 17-21, 33, 43,
58-59, 76, 81-85
AAFSAT Liaison Officer, 85
Operations (Section 3), 8
Orlando, Fla. See Schools, AAF
School of Applied Tactics.

N

McCulloch, Col. John H., 26
McInnon, Col. M. H., 27
Macklin, Col. Raleigh H., 85
Management Control, Office of,
79, 84
Material Center, 28, 39, 97
Material Division, 8
Maxwell Field, Ala. See Schools,
Air Corps Tactical.
Mergher, Lt. Walter R., 67
Mediterranean theater, 4
Mediterranean Allied Command
(M.A.C.), 80
Military Requirements, Direc-
torate of, 10, 13, 15, 24,
28, 39
Minimum-altitude bombing,
37-39, 44
Mission reports, 74-76
Montbrook, Fla., 46
Montgomery, Col. H. G., Jr., 27
Movements and Operations Divi-
sion, OC&R, 19

P

P-47. See Thunderbolt.
Peabody, Col. Hume, 24, 29-30, 40,
51, 67
Personnel problems:
Civilian, 23, 54
Military, 4, 7-8, 11-12, 20-21,
23-24
Photography, 19
Photography, Maps, and Charts, Di-
rectorate of, 10, 16
Plans, AC/AS, 79
Plans and Projects Division, Dir. of
Air Defense, 10, 14
Fighter Command School Liaison Sec-
tion, 10
Plans Division, OCAO, 8, 63
Ploesti mission, 37-38, 44
Proving Ground, 9, 11. See also Com-
mands, Proving Ground.

R

R
9th Bombardment Group, 27

Radar and radio facilities, 26, 40-
41, 53-55, 65

~~RESTRICTED~~
SECURITY INFORMATION

106

Requirements Division, OOR, 18-19, 33, 46, 86
Air Defense Br., 19
Air Support Br., 19
Bombardment Br., 19
Requirements Liaison Br., 19
Tactical Services Br., 19
Robinson, Capt. G. C., 26 n
Royal Air Force, 36-37, 51, 65
Royal Air Force Development Unit, 51, 83

S

Saville, Brig. Gen. Gordon P., 24, 31-32, 41-42, 50-51, 55
Schoenlin, Lt. Col. Robert L., 42 n

Schools:

AAF School of Applied Tactics, 1, 8, 12-10, 44, 46, 58, 63-69, 73-76, 82, 84-86. See also AAF Tactical Center.
Activation of, 25, 91
Air Defense Dept. [Board], 13-14, 25-26, 30
Air Room, 70
Air Service Dept., 25-26
Air Support Dept., 27
Bombardment Dept., 15, 27
Executive Director, 33
Intelligence Dept., 76
Intelligence Digest, 68
Liaison officers. See Intelligence, AC/AS; OOR, AC/AS.
Library, 23, 66-68, 70-75
Tactical Development, Directorate of, 31, 69
Training Aids Directorate, 65-66
Air Corps Tactical, 6-9, 23, 62-63, 65
Air Service School of Application, proposed, 6 n
Air Service School of Tactics, 6
Command and General Staff, 24
Field Officers', 6

Fighter Command, 10-11, 25-26, 27 n, 39, 41, 42 n, 50, 52, 63, 65, 91
Interceptor Command, 25-27. See also Fighter Command School.
Sherman Field, Tex., 16
Sicily, 38
Signal Branch, Dir. of Ground Support, 11
Signal Corps, 55-56
Smart, Col. J. E., 38, 76
Smith, Col. Luther S., 24
Sorensen, Col. Edgar P., 24, 67, 69
Spaatz, Gen. Carl, 80
Special Projects Division, 16
Stark, Lt. Col. Charles W., 50-51
Statistical data, 73, 76, 79
Status and Operations Division, 15
Stratemeyer, Maj. Gen. G. E., 24

T

23d Composite Group, 9
376th Bombardment Group, 38
Tactics, importance of, 1-3; fundamental considerations, 2-3
Tactics and Plans, Asst. for, 19
Tactics and Technique Section, Dir. of Bombardment, 10
Tactics Section, Dir. of Bombardment, 27
Taylor, Brig. Gen. W. R., 25-26
Technical Committee Unit, Intelligence, 8
Technical Inspection, Directorate of, 10
Technical Services, Director of, 10, 16
Technical Services Division, OOR, 19
Tedder, Air Chief Marshal, 4
Theaters of operations, 4, 15, 18, 35, 37-38, 40, 42, 44, 49, 52-56, 67, 70, 73, 76-84, 87-89
Thunderbolt (Republic P-47) aircraft, 39-40, 44, 50-51, 83

~~RESTRICTED~~
~~SECURITY INFORMATION~~

Training:

U, W, Y, Z

AC/AS, 18, 58, 86
And Operations Division, 9
 Training Literature Unit, 9
And Tactics Section, Fight-
 er Div., 14
Division, 15
Literature Division, 23
 Personnel Procurement Sec-
 tion, 23
Literature Section, 65
Standards, 82, 85-87, 93
Tactics and Air Strategy Unit,
 Operations, 8
Transport and Facilities Divi-
 sion, Dir. of Air Support, 16
Tunisia, 4

United Kingdom, 46. See also
 Great Britain.
War Organization and Movement, Di-
 rectorate of, 10, 13, 16, 24
 Special Projects Div., 16
Weather, 19, 42, 76
Weather, Directorate of, 10, 16, 24
Wright Field, Ohio. See Commands,
 Materiel; Materiel Center.
YB-40 aircraft, 45-49, 73
Young, Col., 80
Zimmerman, Col. Don, 24

~~RESTRICTED~~
~~SECURITY INFORMATION~~

MEMORANDUM FOR THE COMMANDING GENERAL, ARMY AIR FORCES: (Office of the Assistant Chief of Air Staff, Intelligence; Attention: Chief, Historical Division)

Subject: Critique of Army Air Forces Historical Studies: No. 13, The Development of Tactical Doctrines at AAFSAT and AAFTAC

~~RESTRICTED~~
~~SECURITY INFORMATION~~

~~RESTRICTED~~
~~SECURITY INFORMATION~~

MEMORANDUM FOR THE COMMANDING GENERAL, ARMY AIR FORCES: (Office of the Assistant Chief of Air Staff, Intelligence; Attention: Chief, Historical Division)

Subject: Critique of Army Air Forces Historical Studies: No. 13, The Development of Tactical Doctrines at AAFSAT and AAFTAC

~~RESTRICTED~~
~~SECURITY INFORMATION~~