

Technical Note on Refrigerating Technologies

Ice Slurry: a Promising Technology

For centuries, ice has been considered as effective storage material for temperatures around 0°C. Using ice can reduce the size of a water storage tank by a factor of two to ten, depending on the temperature range used for operating the system. The reason for the high energy density is the latent heat of phase change. For a pure substance, under constant pressure, at the freezing temperature, a large amount of energy is required to build up a regular crystalline structure, which leads to the solid phase. In the opposite process of melting, the crystal is destroyed and energy released at the same temperature, now called the melting temperature. For temperatures other than 0°C, other materials that exhibit a change of phase, phase-change materials (PCM), can be used. In technical applications, mixtures are the most used. They show a temperature glide (continuous transition) in the enthalpy function during the phase change. If a PCM is finely dispersed in a carrier fluid, a phase-change slurry is obtained. The particles need to be stable and should not lead to high stratification effects in the system, caused by the buoyancy force. Phase-change slurries may be micro-emulsions, shape-stabilized paraffins, clathrates, microencapsulated phase-change slurries, etc.¹ In April 2003, in Switzerland, an international conference and business forum on the new fields of PCM and energy storage based on these materials was organized.² In this type of energy storage, PCMs – which have a high thermal energy density and stable temperature due to the phase change – are also used for the transport of cold or heat. Ice slurry is the oldest and most commonly used substance in the phase-change slurries group. This technical note briefly highlights the state of the art of this promising technology.

Definitions

In early times, to cool their food, the Romans used naturally occurring ice slurries, e.g. snow-water mixtures, crushed ice, flake ice, etc. Last century, ice slurries were created artificially. Initially, these were basically water with large ice particles with a characteristic diameter of one to several centimetres and were mainly used to cool coal and silver or gold mines. The production of fine-crystalline ice slurries then allowed the technique to be applied in small-scale systems, e.g. for the cooling of display cabinets in supermarkets (see *Figure 1*).

It is difficult to define “ice slurries”. Ice slurries can be classified using the following definitions³:

Definition 1: An ice slurry consists of solid ice particles in a fluid forming a suspension with two phases.

Definition 2: A fine-crystalline ice slurry is a substance comprising ice particles with an average (characteristic) diameter which is equal to or smaller than 1 mm.

Definition 2 is a little arbitrary, but still very useful. This technical note only addresses fine-crystalline ice slurries, produced for example with mechanical scraper-type ice-slurry generators. With this method, the ice particles created have a characteristic diameter of approximately 200 µm.

Application in refrigeration systems and environmental benefits

Experience has demonstrated that conventional direct evaporation systems are usually low-cost and are technically very reliable. However, they use the same fluid – the refrigerant – for “production” and “transport” of cold from the central refrigeration unit to the end users (e.g. display cabinets). As a result, these systems contain large masses of refrigerant and, in the case of permanent or accidental leakage, may lead to high losses with drastic consequences for the environment. Furthermore, high system charges of refrigerants lead to higher costs, because new replacements of CFCs and HCFCs are several times more expensive.

In indirect systems, the production of cold and its transport are separated. Cold is transferred in a heat exchanger from the primary to the secondary circuit. Indirect systems facilitate the use of refrigerants such as ammonia (R-717) or propane (R-290). A large number of fluids are available and used as “secondary liquid refrigerants”. The use of ice slurries is a development in such systems where the phase change is used in order to reduce the required mass flow for a given capacity compared with that obtained using a secondary liquid refrigerant.

The difficult search for alternative refrigerants, due to the phasing out of CFCs and HCFCs, has led to the envisaging of the development of ice-slurry technology.

Production methods

Currently, the most commonly applied techniques are mechanical ones. Usually, the refrigerant is evaporated in a cylindrical double-wall evaporator. In the inner domain, a water-additive mixture leads to the creation of ice crystals on the wall; these are then mechanically removed. As the crystals drop into the fluid, the number of ice particles per volume and, therefore also the ice concentration, increases. Mechanical-scraper type ice-slurry generators with:

- rotating knives
- rotating cylindrical slabs (see *Figure 2*)
- rotating brushes
- screws in cylinders

have appeared on the market and are now widely used for experiments and in some installations.

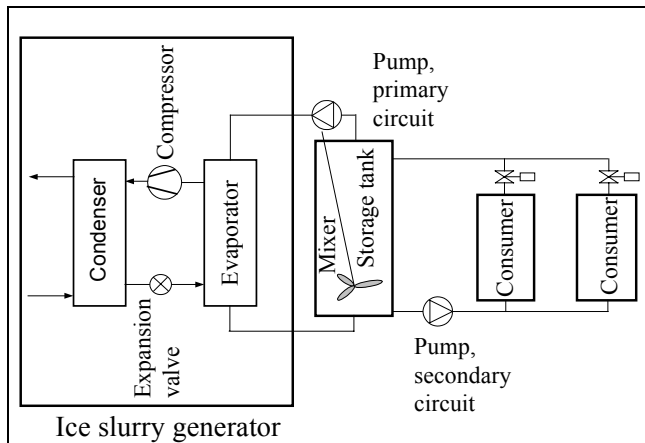

Figure 1. A schematic drawing of an ice-slurry system, e.g. of a supermarket, is shown. The left part shows the ice-slurry generator

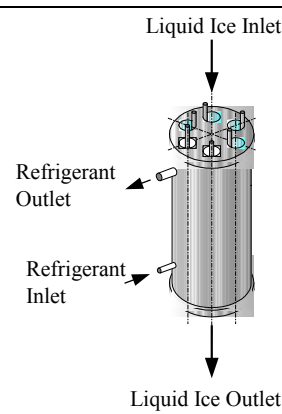

Figure 2. The principle of an ice slurry generator with rotating slabs allows a high ice production rate per volume

Other ice-slurry generators under investigation are:

- vortex-flow type (turbulent fluid eddies remove the ice particles from special treated surfaces with little adhesion)
- direct-injection or direct-heat exchange type (the refrigerant is directly injected into the water)
- fluidized bed ice generator (the flow enables steel or glass spheres to hit the ice crystals and remove them from the wall)
- ice generators using supercooled water with different types of nucleation initiation:
 - by a momentum decrease (flow perpendicular to a cold wall)
 - by an ultra-sound field
 - by bubble nucleation
- vacuum ice generators (the pressure is lowered to the triple point of water)
- hydro scraped generator.

Advantages of ice-slurry technology

The potential advantages of ice-slurry systems, which are listed in this section, are valid in comparison with direct evaporation systems or/and indirect refrigeration systems containing brines as a secondary refrigerant:

- high cooling capacity given by the latent heat
- smaller tube diameters for the piping system (A)
- lower energy demand for the pumps (B)
- practical observations tend to prove that the “quality” of cold produced by ice-slurry systems is improved: better temperature stability, easier moisture and frosting/defrosting management...
- combined with energy storage, the high thermal capacity of the system may bridge small electricity supply cuts
- cheaper electricity and the low nocturnal condensing pressure can be taken advantage of
- increased safety by storing cold in storage tanks
- smaller filling mass of primary circuits
- if the cooling demand of an existing system has to be extended, then the electrical supply does not have to be increased, because cold production can be extended to 24 h
- the peak supply power of cold is many times larger in an ice-slurry system than in a conventional storage system (e.g. an ice-on-coil system).

The system design engineer may choose between (A) and (B) or take partial advantage of both. High heat transfer rates are possible because the ice particles are very finely dispersed in the fluid. *Figure 3* shows numerous ice particles in an ice slurry, and *Figure 4* the related surface of the total amount of ice particles in one kilogram of ice slurry.

Drawbacks and limits

Ice-slurry systems also show some significant disadvantages, which are listed below:

- additional heat exchanger between the primary refrigerant system and the secondary transportation system for cold
- additional pump
- additional energy demand for the pump to charge the storage tank and for the operation of the mixing element
- additional systems for controlling and monitoring the ice-slurry quality
- not adapted for use in air-conditioning and chiller systems, except where savings offered by this technology offset the thermodynamic penalty due to cooling below 0°C to fulfil a cooling task at only 12-14°C
- ice-water systems are most advantageous at temperatures close to the freezing point of water.

The latter disadvantages have recently led to the development of other PCMs, e.g. use of substances such as paraffins. With such substances the melting point can be continuously adjusted to the requirements dictated by the particular application.

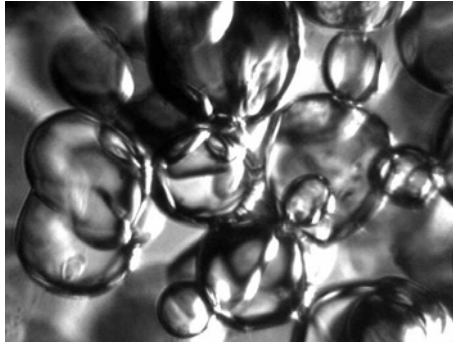

Figure 3. A microscopic photograph of an ice slurry is shown in this figure.³ After their creation, the ice particles grow slightly as a function of time, leading to time-related behaviour of physical properties

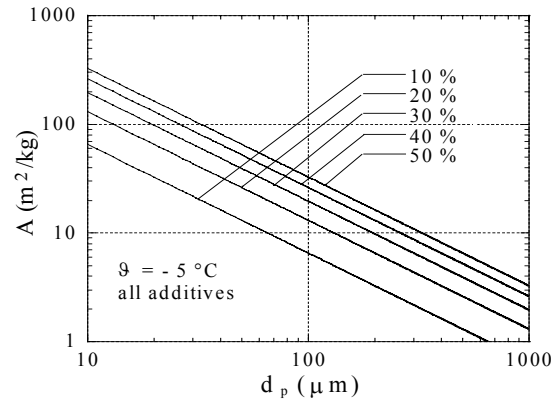

Figure 4. The total surface areas A of all the particles in one kg ice slurry, for different ice mass fractions, are presented. These results are valid for spherical particles with a diameter d_p

Current applications

Ice-slurry systems can be applied in the following domains:

- refrigeration in supermarkets
- cooling in dairies and cheese production facilities
- cooling in breweries
- fast food cooling
- cooling of planes in airports (transport of cold over long distances to the docks)
- cooling of pharma parks (analogous to technoparks, but for pharmaceutical research)
- direct immersion of food (e.g. shrimps).
- cold storage in the food industry, in air conditioning and in district cooling.

These are some examples that can be spread to many other domains.

Possible future applications

Future applications are expected in the following domains:

- plastics production: temperature stabilization leads to more homogeneous temperature profiles in the plastic extruders. This will increase the product quality
- cooling of chemical processes
- immediate stopping of a chemical process by direct injection of ice slurry into the reactor to absorb as much heat as possible, for safety reasons
- mixing of concrete with ice slurry in a quantity so that after the melting of the ice particles exactly the right mass of water is added to the concrete. The latent heat will be used to absorb the reaction heat. Particularly in the construction of road and train tunnels, the technical cooling system may be reduced in size or even economized.

The IIR Working Party on Ice Slurries, which was set up in 1998, has organized five workshops and published proceedings of the papers presented. The contributions cover all important topics that still need to be investigated in order to favour the development of this technology: from physical properties and their time behaviour to fluid dynamics (e.g. pressure drop calculations in piping systems), heat transfer (Nusselt functions) for laminar and turbulent flows, ice generation, storage, mixing, piping, etc. Special contributions will be published in a Special Issue on Ice Slurries of the *International Journal of Refrigeration* in 2004. All useful and available practical knowledge will be brought together in an *IIR Handbook on Ice Slurries*, which will be published in 2005.

Conclusion

Ice slurry is undoubtedly a promising technology that should be encouraged because of its numerous advantages, in particular energy saving and environmental benefits.

Further research and development work needs to be carried out, particularly on how to generate ice slurry in an efficient, reliable and economical way, and on fluid properties and measuring techniques in order to open up this technology for use in a broader range of applications.⁵

References

1. Inaba H. et al. New Challenge in Advanced Thermal Energy Transportation Using Functionally, Thermal Fluids, *Int. J. Therm. Sci.*, 39, 991-1003, 2000.
2. Proceedings of the *Phase Change Material and Slurry Scientific Conference and Business Forum*, Editors Egolf P.W., Sari O. Yverdon-les-Bains, Switzerland, April 23-26, 2003.
3. Egolf P.W., Sari O. A Review from Physical Properties of Ice Slurries to Industrial Ice Slurry Applications. *Proceedings of the Phase Change Material and Slurry Scientific Conference and Business Forum*, 15-25, Yverdon-les-Bains, Switzerland, April 23-26, 2003.
4. Brühlmeier J, Egolf PW. Flüssigeis - ein neuer Kälte-träger. Booklet printed in the framework of a special prize donated by the Swiss Bank Association (UBS), 1996.
5. Granryd E. Perspectives on ice slurries, *Proceedings of the Fifth IIR Workshop on Ice Slurries*, Stockholm, Sweden, 2002.

This Technical Note was prepared by Peter W. Egolf, past President of the IIR Working Party on Ice Slurries and current President of the IIR Working Party on Magnetic Cooling. It was reviewed by IIR experts worldwide.