

NASA TECHNICAL NOTE



NASA TN D-8093

NASA TN D-8093

CASE FILE
COPY

APOLLO EXPERIENCE REPORT - DEVELOPMENT OF THE EXTRAVEHICULAR MOBILITY UNIT

*Charles C. Lutz, Harley L. Stutesman,
Maurice A. Carson, and James W. McBarron II*

*Lyndon B. Johnson Space Center
Houston, Texas 77058*



NATIONAL AERONAUTICS AND SPACE ADMINISTRATION • WASHINGTON, D. C. • NOVEMBER 1975

1. Report No. NASA TN D-8093	2. Government Accession No.	3. Recipient's Catalog No.	
4. Title and Subtitle APOLLO EXPERIENCE REPORT DEVELOPMENT OF THE EXTRAVEHICULAR MOBILITY UNIT		5. Report Date November 1975	
		6. Performing Organization Code JSC-08597	
7. Author(s) Charles C. Lutz, Harley L. Stutesman, Maurice A. Carson, and James W. McBarron II		8. Performing Organization Report No. JSC S-440	
		10. Work Unit No. 914-50-80-01-72	
9. Performing Organization Name and Address Lyndon B. Johnson Space Center Houston, Texas 77058		11. Contract or Grant No.	
		13. Type of Report and Period Covered Technical Note	
12. Sponsoring Agency Name and Address National Aeronautics and Space Administration Washington, D. C. 20546		14. Sponsoring Agency Code	
		15. Supplementary Notes	
16. Abstract This report describes the development and performance history of the Apollo extravehicular mobility unit and its major subsystems. The three major subsystems, the pressure garment assembly, the portable life-support system, and the oxygen purge system, are defined and described in detail as is the evolutionary process that culminated in each major subsystem component. Descriptions of ground-support equipment and the qualification testing process for component hardware are also presented.			
17. Key Words (Suggested by Author(s)) * Environmental Control System * Space Suit * Pressure Garment * Life-Support System * Protective Clothing * Oxygen Purge System		18. Distribution Statement STAR Subject Category: 12 (Astronautics, General)	
19. Security Classif. (of this report) Unclassified	20. Security Classif. (of this page) Unclassified	21. No. of Pages 78	22. Price* \$4.75

APOLLO EXPERIENCE REPORT

EDITORIAL COMMITTEE

The material submitted for the Apollo Experience Reports (a series of NASA Technical Notes) was reviewed and approved by a NASA Editorial Review Board at the Lyndon B. Johnson Space Center consisting of the following members: Scott H. Simpkinson (Chairman), Richard R. Baldwin, James R. Bates, William M. Bland, Jr., Aleck C. Bond, Robert P. Burt, Chris C. Critzos, John M. Eggleston, E. M. Fields, Donald T. Gregory, Edward B. Hamblett, Jr., Kenneth F. Hecht, David N. Holman (Editor/Secretary), and Carl R. Huss. The prime reviewer for this report was Donald T. Gregory.

CONTENTS

Section	Page
SUMMARY	1
INTRODUCTION	1
APOLLO EMU FLIGHT HISTORY	2
PRESSURE GARMENT ASSEMBLY	7
Apollo 11 PGA Configuration	8
Evolution of the PGA	22
Communications Carrier Assembly	29
Bioinstrumentation System	30
DESCRIPTION OF THE PLSS AND THE OPS	34
Apollo 11 PLSS Configuration	35
Apollo 11 OPS Configuration	42
Apollo 15 PLSS and OPS Configurations	43
Evolution of the PLSS and OPS	45
QUALIFICATION TESTING	59
The PGA	60
The PLSS	62
The EMU	64
CREW SUPPORT EQUIPMENT	66
Ventilators	66
Mockups	67
Pad Emergency Air Pack	68
CONCLUDING REMARKS	69

TABLES

Table		Page
I	APOLLO EMU EVA DATA	6
II	PRESSURE GARMENT ASSEMBLY CHARACTERISTICS	7
III	PRESSURE RELIEF VALVE AND PURGE VALVE CHARACTERISTICS	18
IV	LIQUID-COOLING GARMENT CHARACTERISTICS	18
V	THERMAL AND OPTICAL PROPERTIES OF THE LEVA	20
VI	PORTABLE LIFE-SUPPORT SYSTEM CONFIGURATIONS	46
VII	SPECIFICATION REQUIREMENTS FOR THE PORTABLE LIFE-SUPPORT SYSTEM	47

FIGURES

Figure		Page
1	Apollo 11 to 14 EMU	2
2	Apollo 11 PLSS oxygen supply pressure profile for the commander	4
3	Apollo 11 PLSS battery current profile for the commander	4
4	Apollo 11 PLSS sublimator gas outlet temperature profile for the commander	4
5	Apollo 11 PLSS LCG inlet temperature profile for the commander	4
6	Apollo 11 PLSS feedwater pressure profile for the commander	4
7	Apollo 11 PLSS LCG water delta temperature profile for the commander	5
8	Intravehicular pressure garment assembly	9
9	Extravehicular pressure garment assembly	9
10	Extravehicular torso limb suit assembly	9

Figure		Page
11	Torso limb suit assembly liner	9
12	Ventilation system and ventilation flow diagram of the EV TLSA . . .	11
13	Intravehicular torso limb suit assembly	11
14	Pressure helmet and helmet attaching neckring	11
15	Pressure gloves	11
16	Material cross section for EV glove	13
17	Intravehicular cover layer	13
18	Lunar integrated thermal micrometeoroid garment	14
19	Material cross section for ITMG (Apollo 10 to 14 missions)	14
20	Gas connectors	15
21	Liquid-cooling garment multiple water connector	
	(a) Front view	15
	(b) Rear view	15
22	The PGA electrical harness	15
23	Neck dam with lanyard	15
24	Apollo 9 to 12 single-flow purge valve	
	(a) Purge mode	17
	(b) Unactivated	17
25	Apollo 14 to 17 dual-flow purge valve	17
26	Liquid-cooling garment and coolant system	17
27	Lunar boot	17
28	Lunar extravehicular visor assembly (Apollo 13 to 17)	21
29	Constant wear garment	21
30	Waste management systems	
	(a) Fecal containment subsystem	21
	(b) Urine collection and transfer assembly	21

Figure	Page
31	Communications carrier 29
32	Bioinstrumentation system 31
33	Portable life-support system
	(a) Component assembly 34
	(b) Schematic diagram 35
34	Oxygen ventilating circuit schematic 36
35	Diagram of the primary oxygen subsystem 37
36	Liquid transport loop schematic 38
37	Schematic of the PLSS feedwater loop 40
38	Extravehicular communications system for EVC 1 40
39	Extravehicular communications system for EVC 2 41
40	Remote control unit 42
41	Oxygen purge system components 42
42	Oxygen purge system
	(a) Purge mode 43
	(b) Schematic diagram 44
43	Early Apollo PLSS expendables duration (Apollo 9 to 14 missions) 45
44	Extended Apollo PLSS expendables duration (Apollo 15 to 17 missions) 45
45	Sectional view of the sublimator 49
46	The LiOH cartridge
	(a) Canister and reservoir assembly 51
	(b) Canister flow diagram 51
	(c) Cartridge 51
47	Extravehicular communications system pictorial diagram: dual-dual 57

Figure		Page
48	Extravehicular communications system pictorial diagram: dual-secondary	58
49	Extravehicular communications system pictorial diagram: secondary-primary	59
50	Portable oxygen ventilator	67
51	Cryogenic pack	67
52	Pad emergency air pack	68

ACRONYMS

AM	amplitude modulated
BSLSS	buddy secondary life-support system
CDR	commander
CM	command module
CMP	command module pilot
CSM	command and service module
CWG	constant wear garment
ECG	electrocardiograph
ECS	environmental control system
EMI	electromagnetic interference
EMU	extravehicular mobility unit
EOS	emergency oxygen system
EV	extravehicular
EVA	extravehicular activity
EVC	extravehicular communicator
EVCS	extravehicular communications system
EVVA	extravehicular visor assembly
FCS	fecal containment subsystem
FM	frequency modulated
ITMG	integrated thermal micrometeoroid garment
IV	intravehicular
IVCL	intravehicular cover layer
JSC	Lyndon B. Johnson Space Center
LCG	liquid-cooling garment

LEVA	lunar extravehicular visor assembly
LM	lunar module
LMP	lunar module pilot
LOX	liquid oxygen
LRV	lunar roving vehicle
MCC	Mission Control Center
MSC	Manned Spacecraft Center
OPS	oxygen purge system
PCV	pressure control valve
PEAP	pad emergency air pack
PGA	pressure garment assembly
PLSS	portable life-support system
POV	portable oxygen ventilator
PTT	push to talk
PVC	polyvinyl chloride
RCU	remote control unit
SSC	space suit communications
SI	Système International d'Unités
TLSA	torso limb suit assembly
T/R	transmitter/receiver
UCTA	urine collection and transfer assembly
VCO	voltage-controlled oscillator
VOX	voice-operated transmitter
WMS	waste management system
ZPN	impedance pneumograph

APOLLO EXPERIENCE REPORT

DEVELOPMENT OF THE EXTRAVEHICULAR MOBILITY UNIT

By Charles C. Lutz, Harley L. Stutesman, Maurice A. Carson,
and James W. McBarron II
Lyndon B. Johnson Space Center

SUMMARY

The extravehicular mobility unit was developed to provide the Apollo crewman with a life-support system that would enable him to perform useful work tasks in the free-space environment or on the lunar surface. The system could function independently for periods of up to 8 hours, or it could operate with the environmental control systems of the command module or the lunar module to provide life support during planned or contingency cabin depressurization. Technology from the Gemini Program was incorporated wherever possible in the design of the Apollo extravehicular mobility unit. The evolution of the extravehicular mobility unit and the development and testing programs for the major subsystems of the unit are discussed in this report. Operating parameters and the in-flight performance of the unit are also discussed.

INTRODUCTION

This report traces the history of the Apollo extravehicular mobility unit (EMU) worn by crewmen on the lunar surface. The EMU consists of three major subsystems, the pressure garment assembly (PGA), the portable life-support system (PLSS), and the oxygen purge system (OPS). The configuration of these subsystems as used on the Apollo 11 mission is described in detail in this report. The evolutionary process that culminated in the EMU configuration is also presented, and each major subsystem or component is described from its initial concept to its present design, with particular emphasis on the reasons for the changes. Also included in this report are a discussion of the major test programs conducted to qualify the system for flight usage and a summary of the actual in-flight performance.

As an aid to the reader, where necessary the original units of measure have been converted to the equivalent value in the Système International d'Unités (SI). The SI units are written first, and the original units are written parenthetically thereafter.

APOLLO EMU FLIGHT HISTORY

The following information pertains to the in-flight usage of the PGA, the PLSS, and the OPS. The importance of the three major subsystems of the EMU (fig. 1) increased with the complexity of each succeeding flight and the demands of each extravehicular activity (EVA) period.

The Apollo 7 to 10 missions were planned to demonstrate the capability of all flight hardware to operate in space before the actual lunar landing. Because extravehicular activities were not scheduled for the Apollo 7 and 8 flights, the only subsystem of the EMU onboard the spacecraft was the PGA. The primary purposes for using the PGA on these flights were to serve as a backup to the command module (CM) pressure and the environmental control system (ECS) and to protect the crewmen from

noise, vibration, et cetera, during launch and reentry. The performance of the PGA was satisfactory, and each flightcrew reported that PGA ventilation was adequate during the orbital phase of these missions. Doffing and donning were found to be much easier at zero g than at one g and created no problems for the crewmen.

As a result of knowledge gained during the Apollo 7 flight and because of some problems encountered, a few minor design changes were made in the PGA before the Apollo 8 mission. Because of head colds and sinus problems, the Apollo 7 crewmen decided to make the Earth reentry with helmets and gloves removed to provide a means of clearing the sinus and inner-ear cavities (Valsalva maneuver). Because it was desirable to have the complete PGA donned during this critical phase of the flight, a device was incorporated on Apollo 8 and subsequent flight helmets to allow the Valsalva maneuver to be accomplished without removal of the helmet or use of the hands. Because the Apollo 8 mission objective was to circle the Moon and return to Earth and because no EVA was required, all three crewmen wore the intravehicular (IV) configuration of the PGA.

The first use of the complete EMU under flight conditions was accomplished during the Apollo 9 mission. The objective of this mission was to check out and test the lunar module (LM) ascent and descent stages, including the main and attitude propulsion systems; the ECS; and the LM/CM undocking/docking procedures. The Apollo 9 mission was also important for EVA evaluation because some of the LM-to-CM contingency transfer procedures were to be performed. The lunar module pilot (LMP) in the EMU configuration opened the side hatch of the LM and egressed to simulate the contingency transfer, a simulation that lasted for approximately 40 minutes. During the LMP

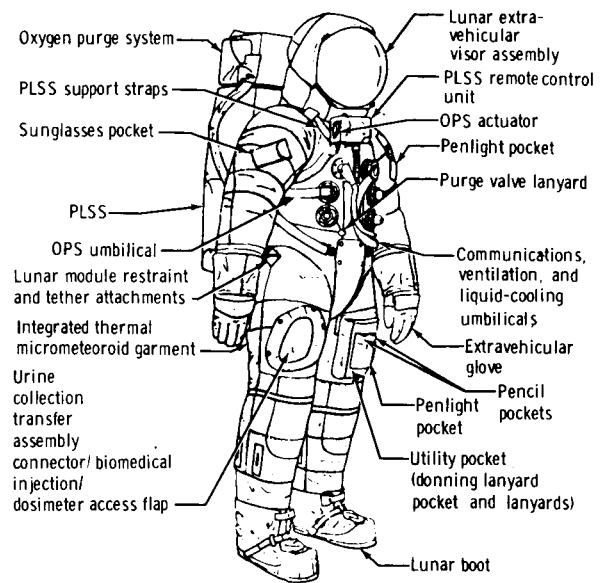

Figure 1. - Apollo 11 to 14 EMU.

EVA, the command module pilot (CMP), while connected to the CM ECS, opened the CM side hatch and maneuvered partially in and out of the hatch several times, retrieving thermal samples and taking photographs. Both crewmen reported that they were comfortable and that they experienced no visual problems with the extravehicular visor assembly (EVVA). The CMP wore one extravehicular (EV) glove and one IV pressure glove; the IV pressure glove (worn for sample retrieval) became warm but not uncomfortable.

The LMP ingressed the LM after completion of the EVA and doffed the PLSS, the OPS, and the EVVA with no problems. At that time, the PLSS was recharged in the LM cabin for possible contingency reuse and for demonstration of the feasibility of this operation under actual flight conditions. The recharge was completed with no problems.

Each Apollo 9 crewman wore his PGA for approximately 52 hours; most of this time was spent in the helmet-and-glove-off or ventilation mode. For approximately 47 minutes of the flight, the PGA's were pressurized to 26 kN/m^2 (3.75 psia).

The Apollo 10 mission was similar to the Apollo 7 and 8 missions in that the EMU was not used for EV activities, and the PGA was used only as a backup to the CM ECS. The performance of the PGA was satisfactory.

The Apollo 11 mission was the first mission on which the EMU was exposed to the lunar environment, for which it had been designed and tested. All aspects of EMU operation demonstrated during testing and on previous flights were proved on the lunar surface. Typical telemetry data received from the lunar surface are presented in figures 2 to 7. An evaluation of EMU performance for the Apollo 11 mission follows.

No significant problems were noted at LM egress. Both crewmen stated that they were comfortable while waiting for the cabin to depressurize, even though the liquid-cooling garment (LCG) inlet temperature exceeded 305 K (90° F) before PLSS sublimator startup. No thermal changes were noted at egress. The crew stated that the PLSS/OPS was thermally quite comfortable and that the mass was not objectionable.

The maximum range traversed on the lunar surface was approximately 60 meters. One crewman commented that the traverse left him a little tired. However, this fatigue occurred toward the end of the EVA, and the crewman had not rested before the EVA.

Mobility and balance in the EMU were sufficient to allow stable movement while performing lunar surface tasks. The LMP demonstrated the capability to walk, run, change direction while running, and stop movement without difficulty. No thermal problems occurred during the EVA; however, the commander's hands sweated inside the EV gloves. Because the commander (CDR) did not wear comfort gloves, his hands tended to slip inside the EV gloves; consequently, there was a loss in his dexterity and ability to handle objects.

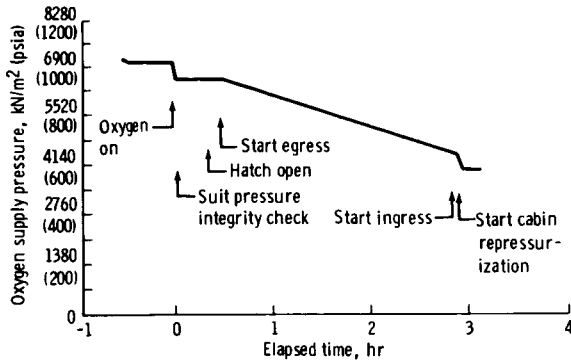

Figure 2.- Apollo 11 PLSS oxygen supply pressure profile for the commander.

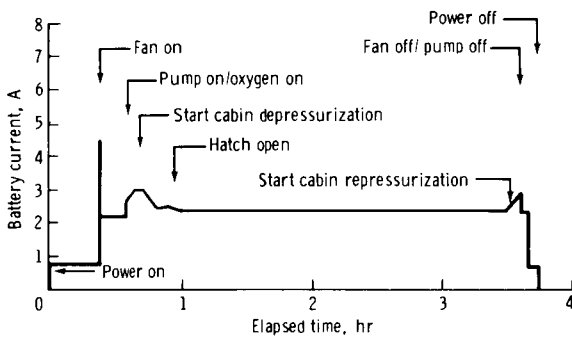

Figure 3.- Apollo 11 PLSS battery current profile for the commander.

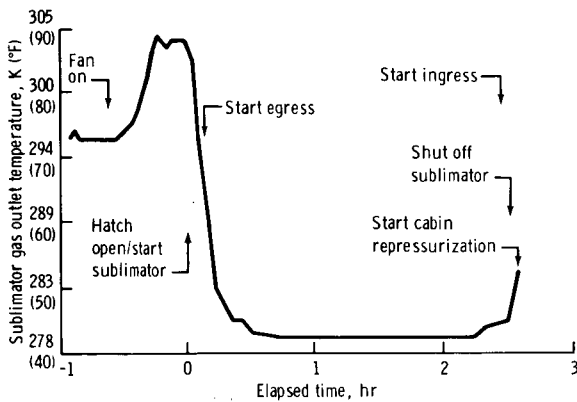

Figure 4.- Apollo 11 PLSS sublimator gas outlet temperature profile for the commander.

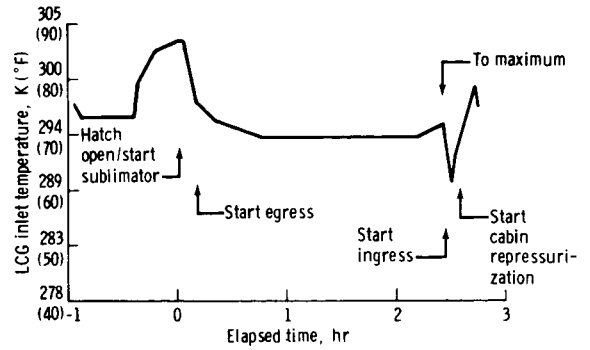

Figure 5.- Apollo 11 PLSS LCG inlet temperature profile for the commander.

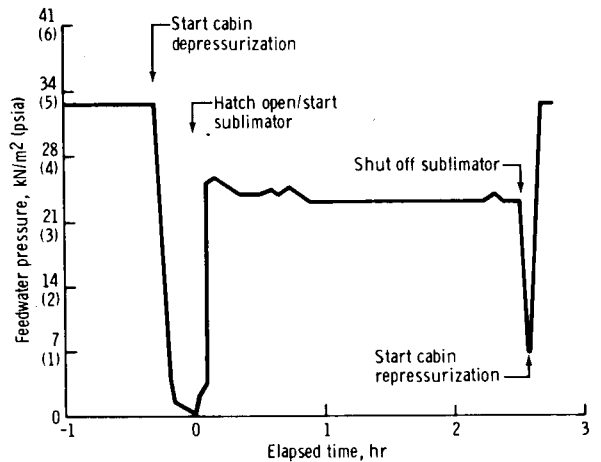

Figure 6.- Apollo 11 PLSS feedwater pressure profile for the commander.

The LCG cooling was adequate, although the recorded temperatures were much higher (warmer) for the CDR than for the LMP. This difference correlates with previous chamber experience, which indicated that the CDR preferred to maintain a warmer body temperature than did the LMP. This parameter is controlled by the crewman to meet his comfort requirements.

The Apollo 12 mission was the first mission that had two EVA periods. Both crewmen spent approximately 4 hours

on the lunar surface during each EVA, and the EMU's performed satisfactorily. Because of the additional EVA, a recharge of each PLSS was performed. No problems were noted during the recharge.

The full EMU's were not used during the Apollo 13 mission because the mission was aborted and a lunar landing was not made. The PGA's were used, however, as backup to the spacecraft ECS.

The Apollo 14 mission consisted of two EVA periods and was the first mission in which the buddy secondary life-support system (BSLSS) was carried. The BSLSS could provide backup cooling if the PLSS cooling loop failed. The BSLSS was necessary because the crewmen traversed approximately 1.5 kilometers from the LM, a distance that was too great to allow return by use of the OPS alone if an emergency occurred. A special two-position purge valve installed in the PGA allowed the oxygen in the OPS to be used at a slower rate than had been necessary before the BSLSS was added. Although the BSLSS was never used, it allowed the crewmen to safely travel greater distances from the LM. The performance of the EMU during the Apollo 14 mission was satisfactory.

The lunar roving vehicle (LRV) was first used during the Apollo 15 mission. The LRV allowed the crewmen to travel even farther from the LM (as far as 7.8 kilometers during the Apollo 17 mission). The improved A7LB PGA and the SV706100-7 model PLSS, which carried additional expendables (water, power, lithium hydroxide (LiOH), and oxygen), allowed much longer EVA's than had been possible on earlier missions. In addition, the number of EVA periods was increased from two to three to allow greater lunar exploration time.

The Apollo 15 mission also included an EVA during the return to Earth, in which the CMP egressed the CM to retrieve a film package from outside the spacecraft. A pressure control valve (PCV) was used in conjunction with an umbilical supplying oxygen from the CM. The OPS was used as a backup system and was worn behind the CMP's helmet.

The Apollo 16 and 17 missions were virtually the same in scope as the Apollo 15 mission, with three lunar surface EVA's and one CM EVA on each mission. The longest EVA of the Apollo Program was the Apollo 17 second lunar surface EVA, which lasted 7 hours 37 minutes. A summary of Apollo EMU EVA data is presented in table I.

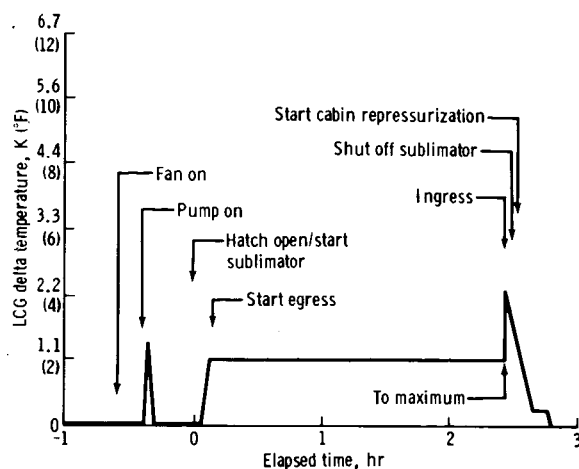

Figure 7. - Apollo 11 PLSS LCG water delta temperature profile for the commander.

TABLE I. - APOLLO EMU EVA DATA

Mission	Date	Type of EVA	Crewman	EVA time, hr:min			
				Standup	Umbilical	Free	Cumulative ^a
Apollo 9	Mar. 1969	Earth orbital	LMP CMP	-- 00:47	-- --	00:47 --	1:34
Apollo 11	July 1969	Lunar surface	CDR LMP	-- --	-- --	02:48 02:48	7:10
Apollo 12	Nov. 1969	Lunar surface (EVA 1)	CDR LMP	-- --	-- --	04:00 04:00	22:42
		Lunar surface (EVA 2)	CDR LMP	-- --	-- --	03:46 03:46	
Apollo 14	Jan. 1971	Lunar surface (EVA 1)	CDR LMP	-- --	-- --	04:48 04:48	41:28
		Lunar surface (EVA 2)	CDR LMP	-- --	-- --	04:35 04:35	
Apollo 15	July 1971	Lunar surface	CDR	00:33	--	--	80:27
		Lunar surface (EVA 1)	CDR LMP	-- --	-- --	06:33 06:33	
		Lunar surface (EVA 2)	CDR LMP	-- --	-- --	07:12 07:12	
		Lunar surface (EVA 3)	CDR LMP	-- --	-- --	04:50 04:50	
		Transearth	CMP LMP	-- 00:38	00:38 --	-- --	
Apollo 16	Apr. 1972	Lunar surface (EVA 1)	CDR LMP	-- --	-- --	07:11 07:11	123:41
		Lunar surface (EVA 2)	CDR LMP	-- --	-- --	07:23 07:23	
		Lunar surface (EVA 3)	CDR LMP	-- --	-- --	05:40 05:40	
		Transearth	CMP LMP	-- 01:23	01:23 --	-- --	
Apollo 17	Dec. 1972	Lunar surface (EVA 1)	CDR LMP	-- --	-- --	07:12 07:12	170:01
		Lunar surface (EVA 2)	CDR LMP	-- --	-- --	07:37 07:37	
		Lunar surface (EVA 3)	CDR LMP	-- --	-- --	07:15 07:15	
		Transearth	CMP LMP	-- 01:06	01:06 --	-- --	
Totals				04:27	03:07	162:27	--

^aRepresents man-hours.

PRESSURE GARMENT ASSEMBLY

The PGA is an anthropomorphic protective assembly that encloses the crewman in a pressurized environment and permits performance of mission tasks in a vacuum ambient pressure condition. The PGA is worn by the crewman during IV spacecraft operations and during EV free-space operations and lunar surface explorations.

The PGA is designed to be worn for a contingency CM transearth return of 115 hours at a regulated pressure of $26 \pm 1.7 \text{ kN/m}^2$ ($3.75 \pm 0.25 \text{ psid}$) in conjunction with either the constant wear garment (CWG) or the LCG. The operating characteristics of the PGA are listed in table II. A detailed description of the A7L PGA's used for the Apollo 11 lunar landing and surface exploration mission follows.

TABLE II. - PRESSURE GARMENT ASSEMBLY CHARACTERISTICS

Characteristic	Value	
	PGA with ITMG ^a	PGA with IV cover layer
Weight, kg (lb)	19.69 (43.42)	15.48 (34.13)
Operational temperature limitations, K (°F)	+394 (+250)	^b 244 to +339 (-20 to +150)
Leak rate at 25.5 kN/m^2 (3.7 psid) max., scc/min (lb/hr)	180.00 (0.0315)	180.00 (0.0315)
Operating pressure, kN/m^2 (psid)	26 ± 1.7 (3.75 ± 0.25)	26 ± 1.7 (3.75 ± 0.25)
Structural pressure, kN/m^2 (psid)	41 (6.00)	41 (6.00)
Proof pressure, kN/m^2 (psid)	55 (8.00)	55 (8.00)
Burst pressure, kN/m^2 (psid)	69 (10.00)	69 (10.00)
Pressure drop, kN/m^2 (in. of H ₂ O) At $0.34 \text{ m}^3/\text{min}$ (12 acfm), 24 kN/m^2 (3.5 psia), 283 K (50° F), with inlet diverter valve open (IV position)	1.17 (4.70)	1.17 (4.70)
At $0.17 \text{ m}^3/\text{min}$ (6 acfm), 27 kN/m^2 (3.9 psia), 298 K (77° F), with inlet diverter valve closed (EV position)	0.45 (1.80)	Not applicable
Pressure gage range, kN/m^2 (psid)	17 to 41 (2.5 to 6.0)	17 to 41 (2.5 to 6.0)

^aIntegrated thermal micrometeoroid garment.

^bSpacecraft wall.

Apollo 11 PGA Configuration

Two configurations of the PGA were worn on the Apollo 11 mission. The A7L IV PGA shown in figure 8 was worn by the CMP. The A7L EV PGA shown in figure 9 was worn by the CDR and the LMP. The two configurations were similar except that the A7L IV PGA was equipped with a lighter weight and less bulky IV cover layer (IVCL) and did not include the hardware and controls necessary for EV use.

Each A7L PGA (IV and EV) consisted basically of a torso limb suit assembly (TLSA) with an integrated protective cover layer, a pressure helmet, pressure gloves, controls, instrumentation, and communication equipment. Additional equipment consisting of a lunar extravehicular visor assembly (LEVA) and lunar boots was provided to complete the EV PGA.

The TLSA. - The TLSA is that part of the PGA that covers the crewman's entire body except his head and hands. The TLSA's for both PGA configurations are basically the same, but some differences exist primarily because of different mission requirements. The A7L EV PGA TLSA will be described fully, and only the differences will be discussed for the A7L IV PGA configuration.

The EV TLSA: The EV TLSA is shown in figure 10. The torso portion of the TLSA is custom sized and the limb portions are graduated in size and adjustable to accommodate individual crewman limb lengths. A pressure sealing and restraint slide fastener closure permits crewman entry into the TLSA. A lock assembly is secured to the restraint assembly to captivate the pressure sealing slider and prevent inadvertent opening.

The pressure-containing bladder of the TLSA is a neoprene-coated nylon fabric. Directly over the bladder outer surface is a nylon restraint layer that controls the conformational shape and provides structural support to the bladder. Dipped-rubber convoluted joints of near-constant volume are located at the shoulders, elbows, wrists, hips, knees, and ankles to permit joint movement with a minimum expenditure of energy. Restraint cables or cords with reinforced attachment points are provided to sustain axial limb loads during pressurized modes of operation and to prevent ballooning of the convoluted joints. A biomedical injection patch is built into the right thigh portion of the TLSA to permit a crewman to self-administer a hypodermic injection without jeopardizing the gas retention quality of the PGA.

The TLSA has an arm bearing to enhance arm rotational movements above the elbow. The PGA boot, which is connected to the TLSA, is sized to the individual crewman's foot and has an ankle convolute designed to permit ankle extension and flexion movements. A metal heel clip is provided to attach the boot to the CM couch footpan for leg restraint during launch and reentry.

The innermost layer of the TLSA is a nylon liner (fig. 11) provided for comfort and to facilitate donning. A series of noncollapsible ducts is attached on the inner surface of the neoprene-coated nylon bladder and serves as part of the ventilation system.

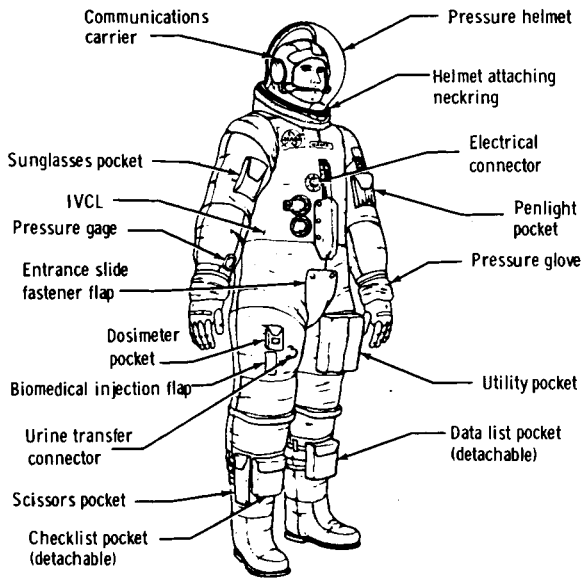

Figure 8. - Intravehicular pressure garment assembly.

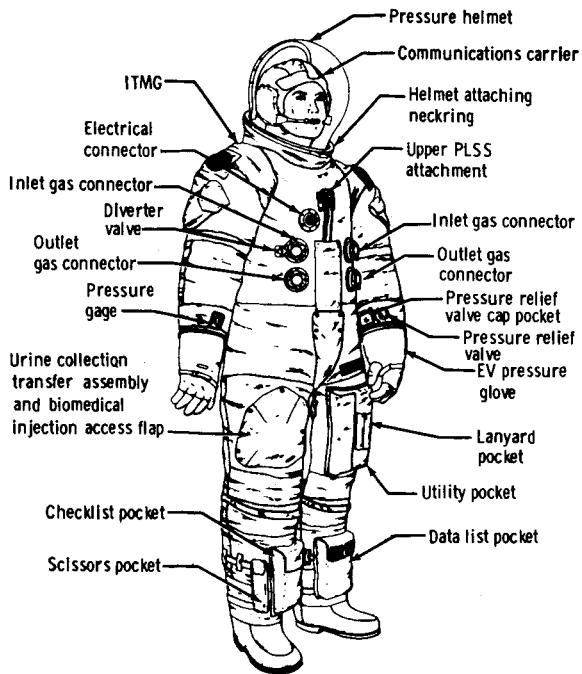

Figure 9. - Extravehicular pressure garment assembly.

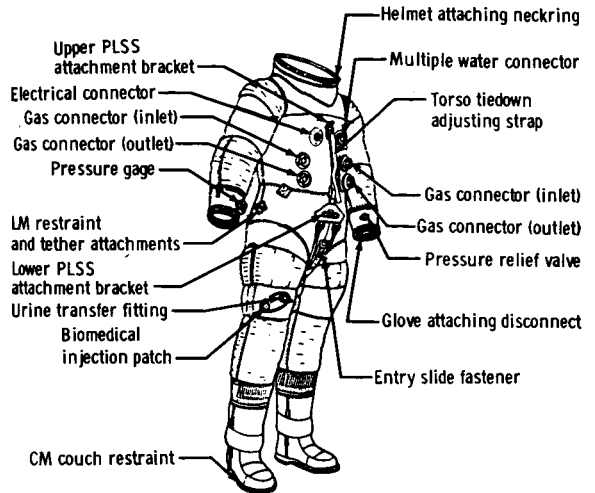

Figure 10. - Extravehicular torso limb suit assembly.

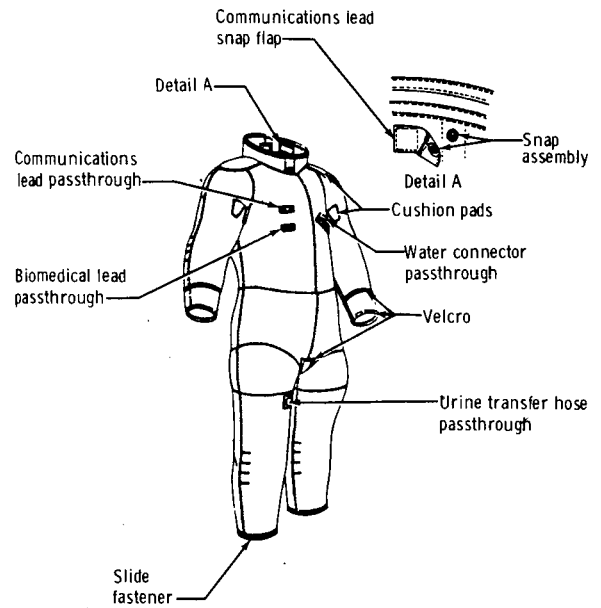

Figure 11. - Torso limb suit assembly liner.

The ventilation system provides for two modes of operation, EV and IV. In the EV mode, all inlet gas flow is directed to the helmet for respiration and helmet defogging. The gas flow then travels over the body to the extremities, where return ducting routes the flow to the suit outlet. In the IV mode, the gas flow is split, with part of the gas flow going into a torso duct and directly over the body and the remaining gas going to the helmet. The ventilation system and ventilation flow paths for the EV TLSA are shown in figure 12. Metal brackets are provided at the upper buckle and lower pulley of the torso tiedown system for attachment of the PLSS restraint straps. The LM restraint tether attachments are located on each side of the PGA torso at the hip area.

The IV TLSA: The IV configuration of the TLSA (fig. 13) is basically the same as that for the EV TLSA. The IV TLSA incorporates an arm assembly with a net restraint elbow joint because the added mobility provided by the arm bearing is not necessary for IV operations. The IV ventilation system requires only one set of inlet and outlet gas connectors with only one torso vent duct, instead of two as used in the EV configuration.

The left arm of the IV TLSA does not incorporate provision for a pressure relief valve because pressure relief capability is provided in the CM ECS. Other components not included in the IV TLSA are the LCG multiple water connector and the LM restraint tether and PLSS attachment brackets.

Pressure helmet assembly. - The pressure helmet is a detachable, transparent closure with provisions for feeding and drinking and for attachment of the LEVA. The helmet is made by a special heat-forming process from high-optical-quality polycarbonate plastic. The helmet and the ring that attaches it to the TLSA are shown in figure 14. The helmet contains a feedport that allows insertion of a probe for administering water and contingency food to a crewman wearing the complete PGA in either the pressurized or unpressurized condition. A synthetic elastomer-foam vent pad bonded to the rear of the helmet shell provides a headrest and acts as a ventilation flow manifold directing gas flow to the oral-nasal area. This flow causes an efficient exhaust of carbon dioxide (CO₂) from the nasal area to the TLSA through the torso neck opening.

Pressure gloves. - The pressure glove is a flexible, gas-retaining device that attaches and locks to the TLSA through a quick-disconnect coupling. There are two basic types of pressure gloves, the IV pressure glove used only for IV operations with the PGA and the EV glove used during EVA's.

The IV glove assembly: The IV glove (fig. 15) is used for IV activities only. Under normal conditions, the gloves are donned only when the suit is pressurized. The IV glove consists primarily of a bladder molded from a cast of the crewman's hand. Dexterity of the bladder is increased by built-in relief projections located over the knuckle areas. A convoluted section is incorporated in the wrist area to provide omnidirectional mobility of the wrist. The convoluted section is restrained by a system of sliding cables secured to the wrist disconnect. The glove side wrist disconnect is the male portion of the wrist disconnect assembly and has a sealed bearing that permits 360° glove rotation. The fingerless glove is a restraint assembly that is cemented onto the bladder at the wrist area and encloses the entire hand except the fingers and

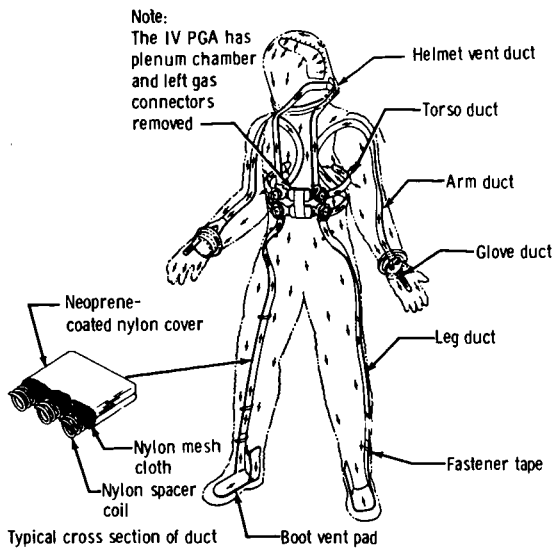

Figure 12. - Ventilation system and ventilation flow diagram of the EV TLSA.

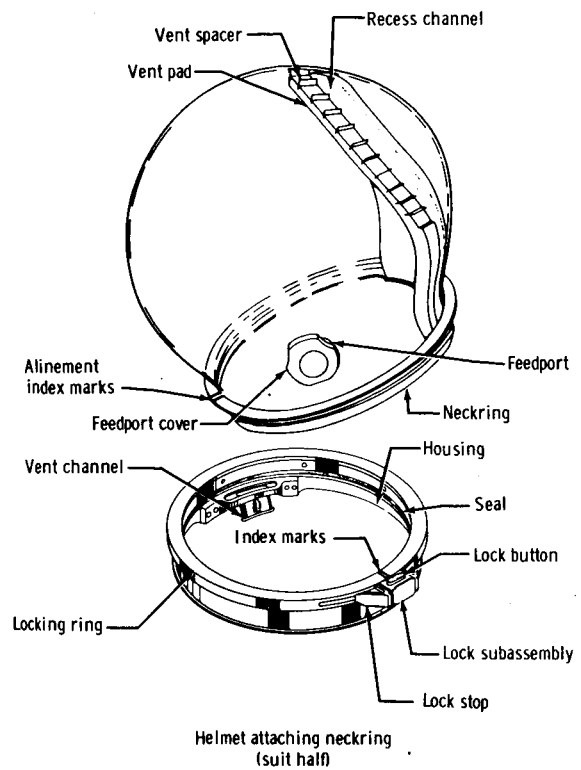

Figure 14. - Pressure helmet and helmet attaching neckring.

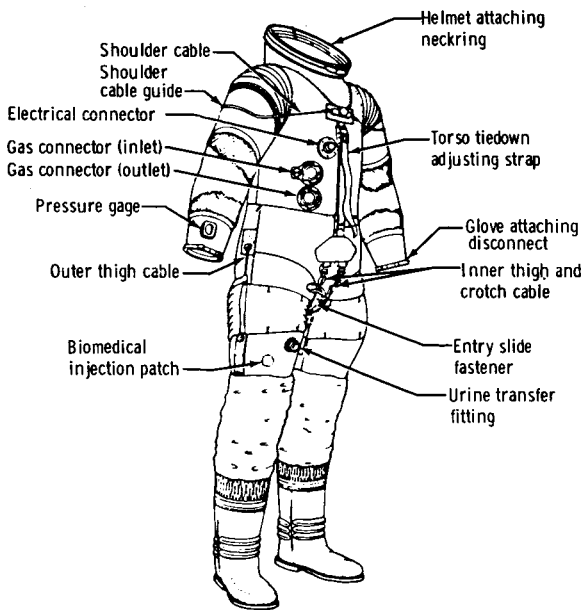

Figure 13. - Intravehicular torso limb suit assembly.

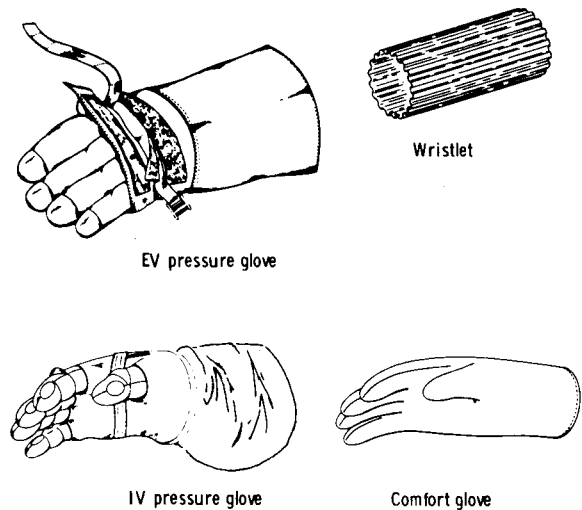

Figure 15. - Pressure gloves.

thumb. A palm restraint strap is used to minimize the ballooning effect created under pressurized conditions and to enhance grip control. The convolute covers protect the bladder and the convolute restraint system. The sliding cable-type convolute restraint system accepts the axial load across the convolute.

The EV glove assembly: The EV glove (fig. 15) is a protective hand cover that interfaces with the TLSA before crewman egress for EV operations. The glove consists of a modified IV pressure glove covered by an EV glove shell. The shell covers the entire hand and has an integral cuff, or gauntlet, that extends above the wrist disconnect on the arm as far as the PGA pressure gage or the pressure relief valve. The EV glove shell, a multilayered assembly, provides scuff, abrasion, and thermal protection for the pressure glove. The material layout of the EV glove is described in figure 16. A woven metal fabric (Chromel-R) is incorporated over the palm and fingers to provide abrasion protection. The thumb and fingertip shells are made of high-strength, silicone-rubber-coated nylon tricot for improved tactility and strength. A silicone dispersion coating is applied to the palm, around the thumb, and to the inner side of each finger to provide increased gripping characteristics. The outer cover is conformal and does not appreciably lessen the flexibility of the inner glove. A flap is sewn onto the back of the glove shell and provides access to the palm restraint strap. The flap is opened or closed by engaging or disengaging the hook-and-pile fastener (Velcro) tape strips. The palm restraint strap can be tightened as necessary to minimize the ballooning effect of pressurization. The shell assembly is secured to the pressure glove at the back and palm of the hand by Velcro tape and near the tip of each finger by two anchor straps and neoprene adhesive.

Cotton wristlets are used to prevent arm chafing caused by the PGA wrist disconnects when the TLSA is worn without the gloves. Comfort gloves constructed of nylon tricot are provided for wear under either the IV gloves or the EV gloves. The comfort glove facilitates donning of the pressure glove and acts as a perspiration absorption layer between the hand and the pressure glove bladder.

Integrated protective cover layers . - Cover layers are integrated with the TLSA to provide added protection to the crewman and to the PGA. The extent of this protection depends on the configuration of the PGA and on the environment to which it will be exposed. The IV PGA is provided with an IVCL, and the EV PGA is provided with an integrated thermal micrometeoroid garment (ITMG).

The IVCL: The IVCL (fig. 17) is a three-layer overgarment designed to protect the crewman and the TLSA from abrasion. The IVCL is conformal to the TLSA, with mobility relief incorporated into the knee, elbow, shoulder, and hip areas. The cover layer is composed of three layers: an inner layer of Nomex cloth and two outer layers of nonflammable Teflon-coated-filament Beta cloth. Additional abrasion layers (constructed of one thickness of Teflon-coated-filament Beta cloth) are added to the exterior of the suit at the knee, elbow, and shoulder areas. An abrasion pad, constructed of Nomex felt, is attached to the suit at each shoulder. Additional scuff protection is provided by Teflon cloth patches in high abrasion areas.

Flap assemblies provide access through the IVCL for the entrance closure, the biomedical injection disk, and the urine collection and transfer assembly (UCTA) connector. These flap assemblies have identical cross sections to the main body of the IVCL. The IVCL also includes a flashlight pocket on the upper right arm section,

Material	Function 1	Function 2	Function 3
PGA glove	Pressure retention	Thermal cross section	Thermal, micrometeoroid protection pressure retention cross section
Aluminized Mylar* (7 layers)	Insulation film		
Nonwoven Dacron* (6 layers)	Insulation spacer		
Teflon-coated filament Beta cloth	Nonflammable shell		
Gauntlet			
PGA glove	Pressure retention	Thermal cross section	Thermal, micrometeoroid protection pressure retention cross section
Aluminized Mylar* (7 layers)	Insulation film		
Nonwoven Dacron* (6 layers)	Insulation spacer		
Silicone-rubber-coated nylon tricot	Increased tactility shell		
Thumbtip and fingertips			
PGA glove	Pressure retention	Thermal cross section	Thermal, micrometeoroid protection pressure retention cross section
Aluminized Mylar* (7 layers)	Insulation film		
Nonwoven Dacron* (6 layers)	Insulation spacer		
Chromel-R metal fabric	Nonflammable and abrasion and heat resistant		
Palm, thumb, and fingers			

*Alternating layers of insulation and spacer.

Figure 16. - Material cross section for EV glove.

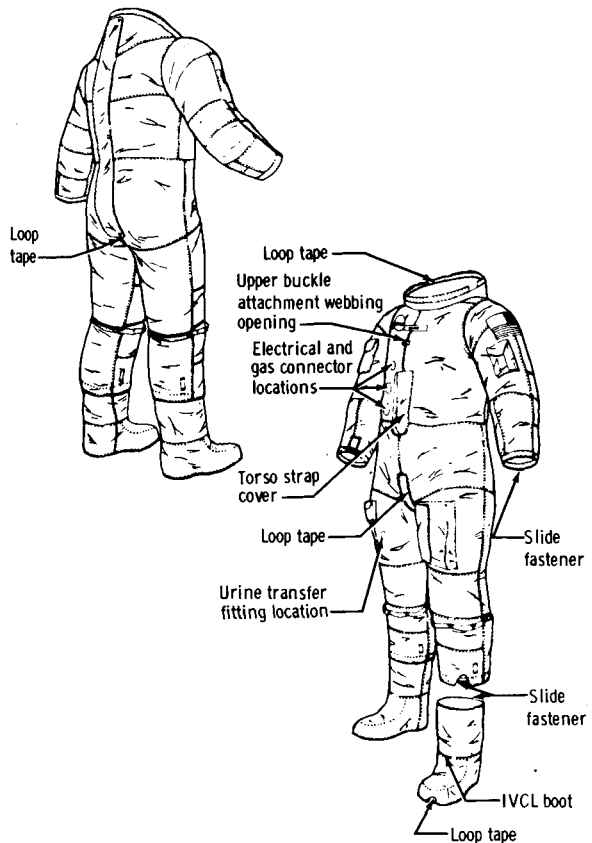

Figure 17. - Intravehicular cover layer.

and a utility pocket on the upper left thigh section. All pocket assemblies are constructed of an outer layer of Beta cloth over an inner layer of Nomex fabric, and all are held closed by flameproof Velcro on the flaps.

An IVCL boot cover assembly fits over the TLSA boot and is secured by loop tape located around the top and the bottom of the boot. The IVCL boot cover assembly is constructed of the same materials as the IVCL.

The ITMG: The ITMG (fig. 18) is a lightweight multilaminate assembly designed to cover and conform to the contours of the TLSA. The layers of materials composing the ITMG provide protection against the thermal and micrometeoroid hazards encountered during the free-space and lunar excursions of an Apollo mission. The cross section of the ITMG materials is shown in figure 19. For protection against abrasion, an additional external layer of Teflon fabric is attached to the knee, waist, elbow, and shoulder areas, and a layer of Chromel-R is added on the back under the PLSS.

Pockets are provided on the shoulder of each arm and on the thigh of the left leg. Three belt loops are secured at the bottom of each leg for holding the detachable data list pocket and the checklist and scissors pockets. An active dosimeter pocket is located under the UCTA connector and biomedical injection access flap.

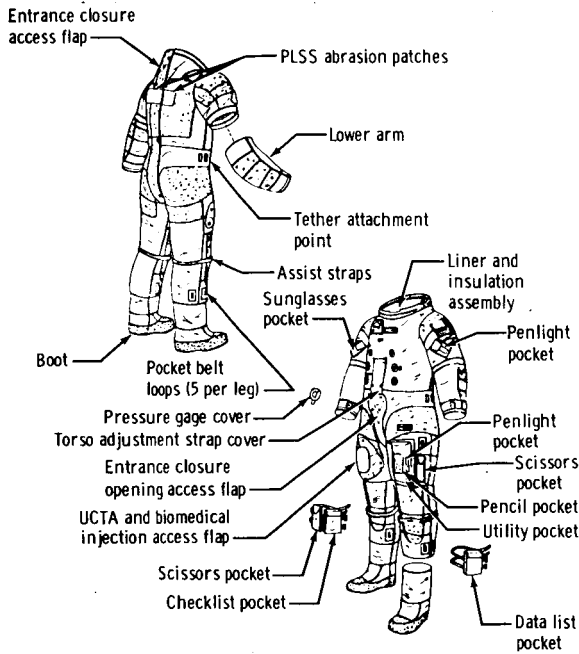

Figure 18. - Lunar integrated thermal micrometeoroid garment.

Access flaps constructed of a thermal-resistant cross section of materials are held closed by a system of snap fasteners and fire-resistant Velcro tape. These access flaps cover the entrance closure and the UCTA connector and biomedical injection area. Thermal protective covers provide protection to the pressure relief valve and the PGA pressure gage while permitting continuous monitoring of the suit pressure.

The ITMG boots cover the PGA boots except for the sole and heel. Each boot assembly has the same cross section as the ITMG. A system of loop tape and lacing cord secures the ITMG boots to the PGA boots at the boot top and around the sole and heel area. A zipper is provided at the top of each boot for attachment to the leg of the ITMG. A Teflon patch encircling the ankle is added to each ITMG boot assembly to prevent abrasion caused by the lunar boot.

The PGA connectors, controls, and instrumentation. - The PGA contains various connectors, controls, and instrumentation necessary (1) to interface with the spacecraft ECS, (2) to allow the crewman to make adjustments for comfort and safety, (3) to allow the crewman to monitor system status, and (4) to interface with the PLSS and OPS (EV PGA only). All the oxygen and pressure integrity connectors have positive redundant locking devices that permit safe connection and disconnection by an unassisted crewman in a vacuum.

Gas connector: Both PGA configurations are provided with an inlet and an outlet gas connector (fig. 20) for interfacing with the ventilation loops of the ECS, the PLSS, or other life-supporting systems. The EV PGA, however, is provided with two sets: two inlet connectors interconnected by a plenum chamber and two outlet connectors

Material	Function 1	Function 2	Function 3
Rubber-coated nylon (ripstop)	Inner liner	Thermal cross section	Thermal, micrometeoroid protection cross section
Aluminized Mylar* (5 layers)	Thermal radiation protection		
Nonwoven Dacron* (4 layers)	Thermal spacer layer		
Aluminized Kapton film/Beta marquisette laminate (2 layers)	Thermal radiation protection		
Teflon-coated filament Beta cloth	Nonflammable and abrasion protection layer		
Teflon cloth	Nonflammable abrasion patches		

*Alternating layers of insulation and spacer.

Figure 19. - Material cross section for ITMG (Apollo 10 to 14 missions).

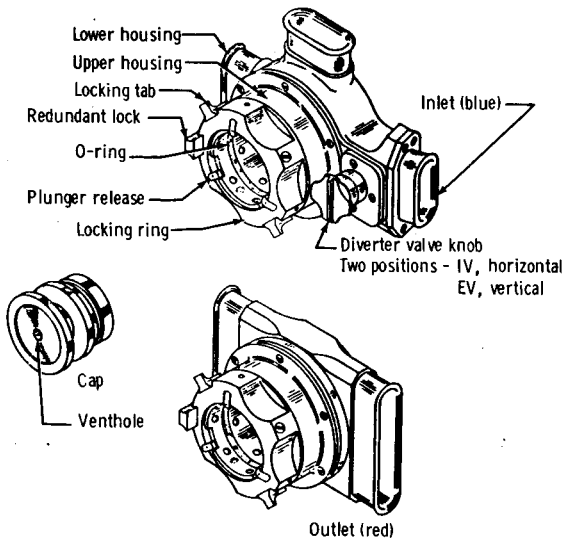

Figure 20. - Gas connectors.

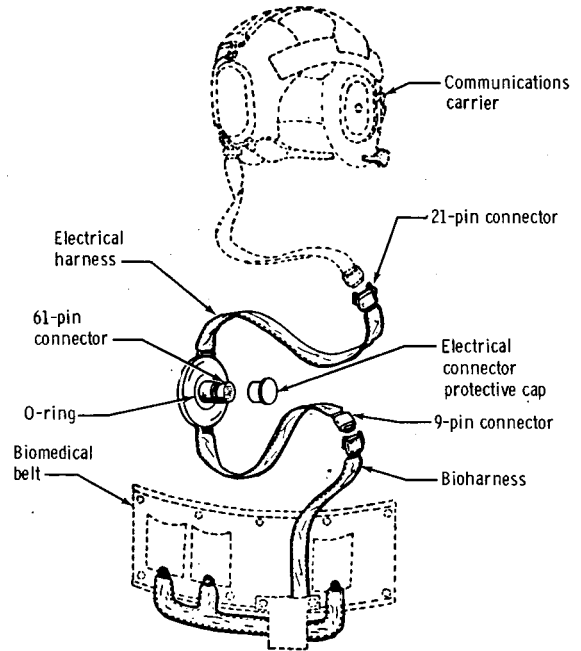
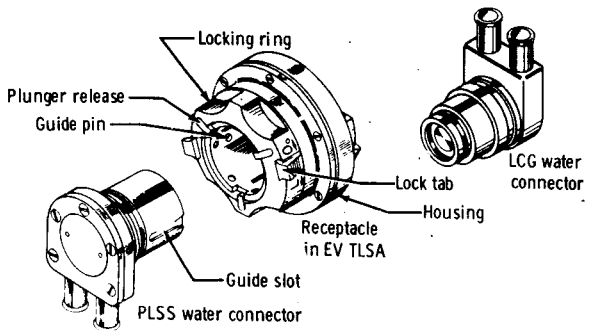
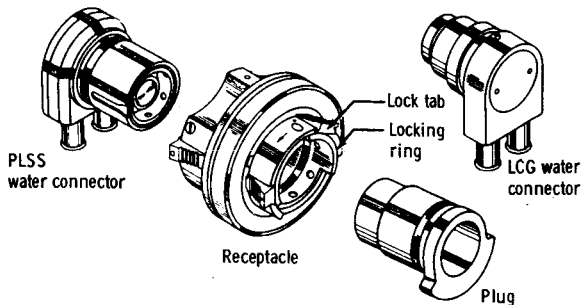

Figure 22. - The PGA electrical harness.



(a) Front view.



(b) Rear view.

Figure 21. - Liquid-cooling garment multiple water connector.

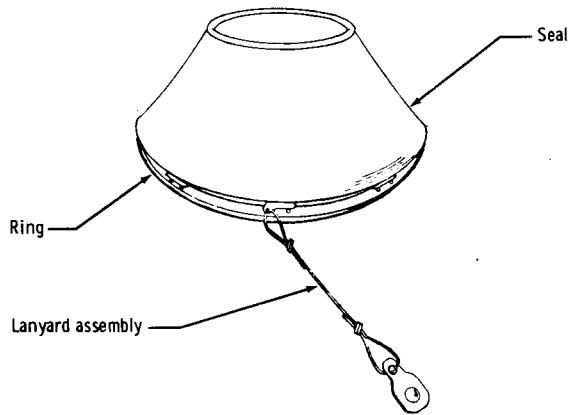

Figure 23. - Neck dam with lanyard.

interconnected the same way. This configuration is required to provide an uninterrupted gas flow and a constant pressure during transfer between life-support systems.

Multiple water connector: The multiple water connector (fig. 21) is a dual-passage ball/lock assembly consisting of a receptacle, an LCG water connector, a PLSS water connector, and a plug. The receptacle is mounted on the EV PGA and acts as the interface between the LCG connector and the PLSS water connector. A protective internal plug provides PGA pressure integrity after the LCG water connector has been removed from the PGA multiple water receptacle.

The UCTA connector and hose installation: The UCTA connector and hose installation consists of a ball/lock connection and a sized length of hose. The connector is flange mounted to the right leg thigh cone and is designed to receive the spacecraft waste management umbilical. The hose assembly is attached to the inner connector and extends to a male adapter that mates with the UCTA connector. The installation is designed to convey waste from the UCTA to the spacecraft waste management system (WMS).

Electrical harness and bioharness: The PGA electrical harness (fig. 22) has a central 61-pin connector from which two branches extend. One branch is used to connect the harness to the communications carrier, and the second, shorter branch is connected to the bioharness. The communications branch includes a 21-pin connector, and the bioinstrumentation branch has a 9-pin connector. Each branch is covered with a Teflon fabric sheath and a Teflon fabric cover and is attached to each connector by a metal clamp. The central 61-pin connector is designed to receive the ball/lock engagement mechanism of the communications and bioinstrumentation umbilical of the spacecraft or the PLSS.

Neck dam: A rubber neck dam (fig. 23) engages the helmet attaching ring to prevent water from entering the suit during CM water egress. A restraining lanyard that snaps onto the PGA is provided.

The PGA controls consist of two-position ventilation-flow diverter valves located on the inlet gas connectors, a pressure relief valve, and a detachable, manually activated purge valve (figs. 24 and 25) used for EV operation with the OPS. The characteristics of the pressure relief valve and the purge valve are listed in table III. The PGA displays consist of a pressure gage (14 to 41 kN/m² (2.0 to 6.0 psid)) mounted on the lower arm.

The LCG. - The LCG is worn next to the skin under the PGA during LM activities and EVA's. The LCG (fig. 26) is made of nylon spandex knitted material and provides for general comfort, perspiration absorption, and thermal transfer between the crewman's body and the cooling fluid in the garment. The garment provides a continuous flow of temperature-controlled water through a network of polyvinyl chloride (PVC) tubing stitched to the inside surface of the open-mesh fabric garment. A lightweight nylon comfort liner separates the body from the tubing network. Front closure is by a slide fastener.

The LCG coolant water from the PLSS passes through the inlet passage of the multiple water connector and circulates through the manifold and the tubing network. The LCG can also be supplied with coolant water from the lunar module. The network of tubing has a parallel flow path providing maximum surface coverage for optimum cooling. Although the LCG has attached, custom-sized socks, the socks do not

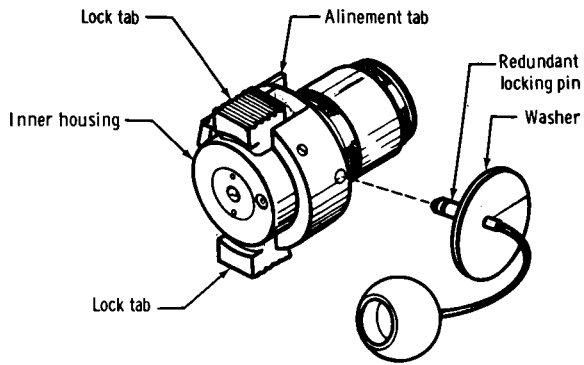

(a) Purge mode.

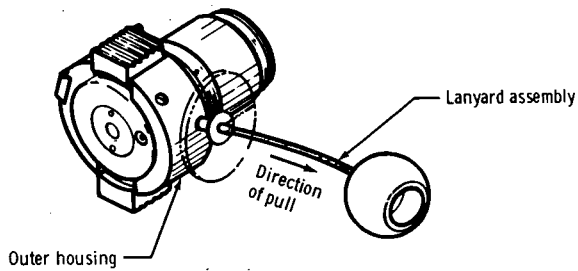

(b) Unactivated.

Figure 24. - Apollo 9 to 12 single-flow purge valve.

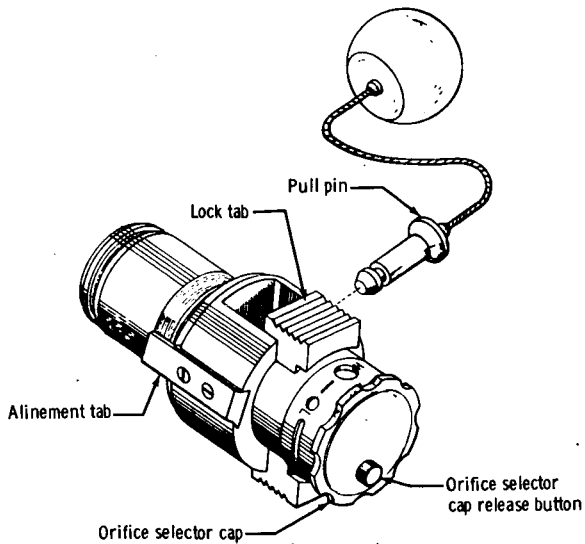

Figure 25. - Apollo 14 to 17 dual-flow purge valve.

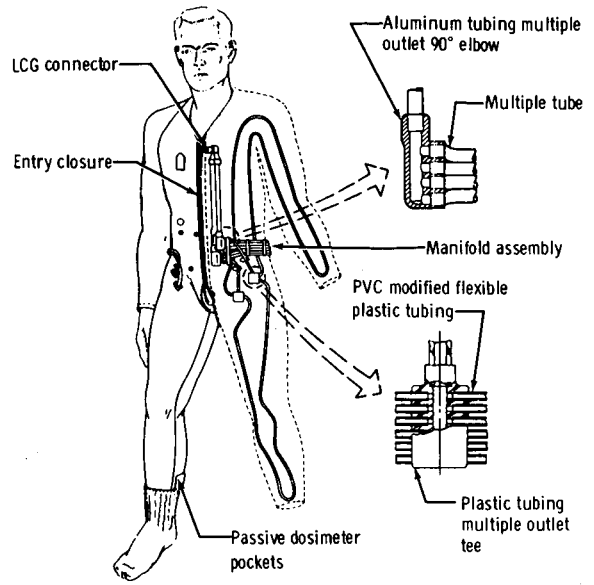

Figure 26. - Liquid-cooling garment and coolant system.

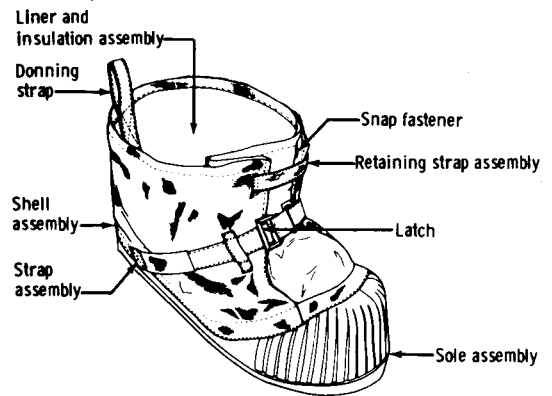

Figure 27. - Lunar boot.

TABLE III. - PRESSURE RELIEF VALVE AND PURGE VALVE CHARACTERISTICS

Characteristics	Value	
	Pressure relief valve	Purge valve
Weight, kg (lb)	Not applicable	0.29 (0.63)
Operational pressure limits, kN/m ² (psid)	55 (8.0)	55 (8.0)
Leak rate, scc/min		
At 26 ± 1.7 kN/m ² (3.75 ± 0.25 psid)	Not applicable	4.0
At 35 kN/m ² (5.0 psid) before cracking	4.0	Not applicable
At 32 kN/m ² (4.6 psid) after reseal	4.0	Not applicable
Cracking pressure, kN/m ² (psid)	35 to 40 (5.0 to 5.75)	Not applicable
Flow rate, kg/hr (lb/hr)		
At 40.3 kN/m ² (5.85 psia)	5.53 (12.2)	Not applicable
At 28 kN/m ² (4.0 psia)	Not applicable	3.62 (8.0)

TABLE IV. - LIQUID-COOLING GARMENT CHARACTERISTICS

Weight (charged), kg (lb)	2.09 (4.60)
Operating pressure, kN/m ² (psid)	29 to 158 (4.20 to 23.0)
Structural pressure, kN/m ² (psid)	217 ± 3 (31.50 ± 0.50)
Proof pressure, kN/m ² (psid)	217 ± 3 (31.50 ± 0.50)
Burst pressure, kN/m ² (psid)	328 (47.50)
Pressure drop, kN/m ² (psi), at 1.8 kg/min (4.0 lb/min) and 294 ± 5.5 K (70° ± 10° F) inlet	^a 22 (3.2)
Leak rate, cm ³ /hr, at 131 kN/m ² (19.0 psid) and 280 K (45° F)	0.058

^aIncluding both halves of connector.

incorporate the cooling tubes. The coolant water is warmed by heat transfer from the crewman's body. The warm water returns to the PLSS through the outlet channel of the multiple water connector. The LCG can remove heat at a maximum rate of 586 watts (2000 Btu/hr). Characteristics of the LCG are given in table IV.

Lunar boots . - The lunar boots (fig. 27) provide thermal and abrasive protection for the PGA boots during lunar surface operations. The lunar boots are donned by inserting and positioning the PGA boots with the donning straps (located at the top rear of each lunar boot) and engaging the snap strap. A strap that extends across the instep from each heel is also latched to provide a more secure fastening. The latching mechanism of the strap can be activated by a crewmember wearing EV gloves.

Except for the sole, the outer layer of a lunar boot is fabricated from metal Chromel-R woven fabric; the tongue area, from Teflon-coated Beta cloth. Ribs project from the bottom of the silicone rubber sole to increase thermal insulation qualities, to provide lateral rigidity, and to provide traction on the lunar surface.

The inner layers (from the Chromel-R fabric inward) consist of two layers of aluminized polyimide (Kapton) followed by five layers of aluminized perforated Mylar separated by four layers of nonwoven Dacron followed by an inner liner of Teflon-coated Beta cloth. Two layers of Nomex felt in the sole provided additional thermal insulation from the lunar surface.

The LEVA . - The LEVA (fig. 28) furnishes visual, thermal, and mechanical protection to the crewman's helmet and head. The LEVA is composed of a plastic shell, three eyeshades (left, center, and right), and two visors. The outer visor, or Sun visor, is made of high-temperature polysulfone plastic. The inner visor, or protective visor, is made of ultraviolet-stabilized polycarbonate plastic. The outer visor filters visible light and rejects a significant amount of ultraviolet and infrared rays. The inner visor filters ultraviolet rays, rejects infrared rays, and, in combination with the Sun visor and pressure helmet, forms an effective thermal barrier. The two visors in combination with the helmet protect the crewmember from micrometeoroid damage and from damage that could result if he fell on the lunar surface. A hard shell protects the Sun visor during nonuse periods. The eyeshades are adjusted by the crewman to prevent glare from obscuring vision during EVA.

The Sun visor and eyeshades may be individually positioned anywhere between "full up" and "full down," but the protective visor is used in the "full down" position for EV operations. A crewman can attach or detach the LEVA from his helmet without the aid of tools. A latching mechanism allows the lower rim of the LEVA to be tightened and secured around the neck area of the pressure helmet. The mechanism consists of an overcenter latch that locks on the lower rim, draws the two sides together, and holds them secure. The LEVA/PGA interface collar provides thermal and dust protection for the neckring. The LEVA thermal and optical properties are listed in table V.

The CWG . - The CWG (fig. 29) is a cotton fabric undergarment worn next to the skin during IV CM operation. The CWG provides general comfort and perspiration absorption and holds the bioinstrumentation system. In the CM, the CWG is worn under the PGA.

TABLE V. - THERMAL AND OPTICAL PROPERTIES OF THE LEVA

Parameter	Spectral band wavelength λ , μm			
	Ultraviolet, to 0.38	Visible, 0.38 to 0.76	Near infrared, 0.76 to 3.0	Far infrared, from 3.0
Pressure helmet				
Reflectance inside, ρ_i	0.14	0.01	0.15	0.07
Reflectance outside, ρ_014	.01	.15	.07
Transmittance, τ18	.92	.68	.00
Emittance inside, ϵ_i	--	--	--	.93
Emittance outside, ϵ_0	--	--	--	.93
Impact protective visor				
Reflectance inside, ρ_i	0.13	0.07	0.50	0.90
Reflectance outside, ρ_007	.11	.37	.05
Transmittance, τ00	.63	.37	.00
Emittance inside, ϵ_i	--	--	--	.10
Emittance outside, ϵ_0	--	--	--	.95
Sun visor				
Reflectance inside, ρ_i	0.08	0.04	0.66	0.94
Reflectance outside, ρ_008	.28	.58	.06
Transmittance, τ01	.19	.12	.00
Emittance inside, ϵ_i	--	--	--	.06
Emittance outside, ϵ_0	--	--	--	.94

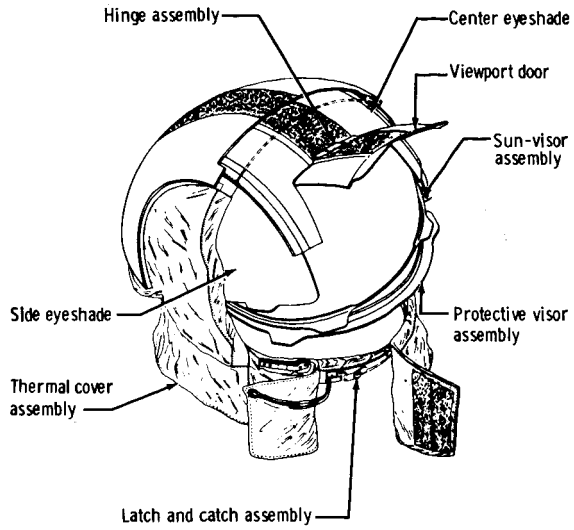
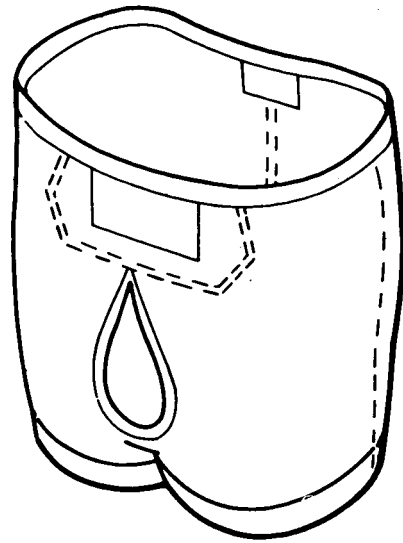

Figure 28. - Lunar extravehicular visor assembly (Apollo 13 to 17).



(a) Fecal containment subsystem.

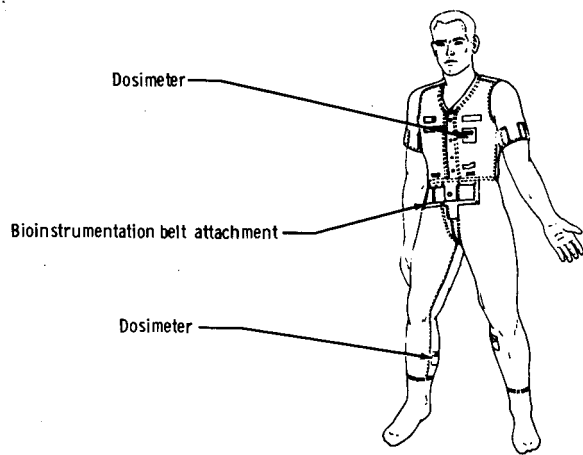
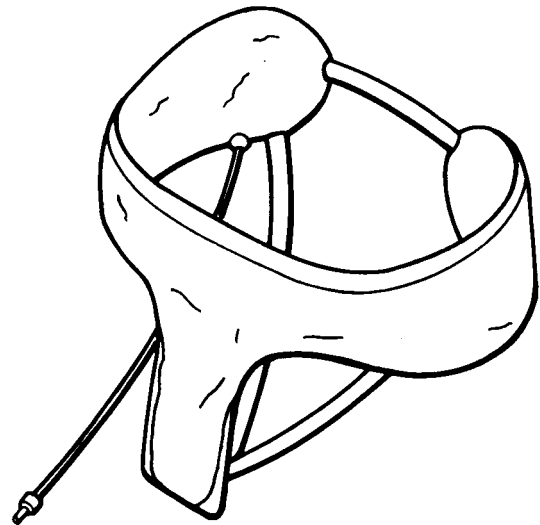

Figure 29. - Constant wear garment.



(b) Urine collection and transfer assembly.

Figure 30. - Waste management systems.

Waste management provisions are provided by a fly opening and a buttock port in the CWG to allow urination and defecation to the CM WMS without removing the garment. Snaps are provided to attach the biobelt, which contains the bioinstrumentation.

The WMS . - Management of body waste when the PGA is donned is accomplished through the fecal containment subsystem (FCS) and the UCTA.

The FCS: The FCS (fig. 30(a)) consists of elastic underwear with an absorbent liner around the buttock area. This subsystem is worn under the LCG or CWG to allow emergency defecation when the PGA is pressurized. The FCS weighs 0.227 kilogram (0.50 pound) and has a capacity of 1000 cubic centimeters of solids.

The UCTA: The UCTA (fig. 30(b)) provides for collection and intermediate storage of a crewman's urine during lift-off, EVA, or emergency modes when the spacecraft WMS cannot be used. The UCTA will accept urine at rates as high as $30 \text{ cm}^3/\text{sec}$ with a maximum stored volume of 950 cubic centimeters. No manual adjustment or operation by the crewman is required while the UCTA is collecting urine. Pressure relief valves are incorporated in the urine collection bag to prevent exposure of the body to pressure differentials of $\pm 249 \text{ N/m}^2$ (± 1 inch of water) between the collection bag and the PGA. The valves open automatically as required to increase pressure in the collection bag. A flapper check valve prevents reverse flow from the collection bag to the urinal portion of the UCTA. The stored urine can be transferred through the suit wall by hose, when feasible, to the CM or LM during either pressurized or depressurized cabin operation.

The UCTA is worn over the CWG or the LCG and is connected by hose to the urine transfer connector on the PGA. This urine transfer connector is a quick-disconnect fitting that is used for the transfer of urine from the UCTA to the spacecraft WMS. A UCTA transfer adapter is provided onboard the CM for use by the crewmen to dump the UCTA's after the PGA's have been doffed.

Evolution of the PGA

The discussion of PGA evolution includes the A5L, A6L, A7L, and A7LB PGA models.

The A5L PGA model. - The configuration of the PGA selected for use in the Apollo Program resulted from a competitive evaluation of three different prototype models in 1965. The PGA configuration selected was designated the AX5L PGA and consisted of a TL5A, IV pressure gloves, and a bubble-shaped helmet. Improvements and changes identified during the evaluation were incorporated, and the model was redesignated the A5L PGA. Changes incorporated into the A5L PGA configuration included use of a pressure sealing closure (similar to that of the G-4C model Gemini space suit) with reinforcement gussets added at each end, use of Velcro to attach the inner liner to permit easy removal for cleaning, addition of lace sizing adjustments at the elbow and knee joints, and repositioning of the neckring to provide the correct crewman eye-to-heart angle required for launch acceleration. Antichafing or anti-abrasion patches also were added on various convolutes and areas of the pressure bladder at high-wear points.

The A5L PGA was used for design verification testing, crewmember evaluations, and spacecraft systems configuration reviews. Use of the A5L PGA in these programs resulted in additional changes and improvements, which were incorporated into the A6L PGA model.

The A6L PGA model .- The A6L PGA was originally intended to be the crew training and flight configuration model. Changes and improvements resulting from testing and crew evaluation of the A5L PGA that were incorporated in the A6L PGA included addition of a mobility joint at the ankles to provide for easier donning and doffing of the boots, lengthening of the pressure sealing closure in the front lower torso to increase ease of donning and closing of the closure, replacement of the neckring with a more reliable and positive locking type that had retractable latches instead of the single-piston-ring type used in the A5L design, and redesign of electrical connectors and wrist disconnects to provide easier-to-operate and more positive locking features.

Most of these changes were made to improve crew operation of the PGA; however, one significant change was made as a result of a cable failure that occurred during low-pressure chamber testing of the EMU. The cable break in the crotch area occurred during a step-up/step-down exercise to simulate high metabolic loads. The friction and loading imposed on the cable, which passed through Teflon guides while restraining the axial force induced by thigh convolute motion, caused the cable to break. These Teflon guides cracked and caused excessive wear on the cable, which eventually broke. The crotch/thigh restraint system was redesigned to incorporate a pulley on the inside of each leg in lieu of the Teflon guides, a change that enabled a more erect standing posture and increased ease in moving this joint area.

Another problem area uncovered during testing and use of the A6L PGA was ballooning of the boot sole when the PGA was pressurized, causing standing instability of the crewman and an interference with the spacecraft couch foot restraint. This problem was solved by reinforcing the boot sole with a lightweight internal aluminum honeycomb truss core.

New mission requirements also resulted in changes to the A6L PGA configuration. These changes included removing the relief valve from the upper leg and redesigning it so that it could be plugged into a gas connector. This relief valve was required only for PLSS operation to prevent PGA overpressurization that would result if the PLSS high-pressure oxygen regulator failed. Because both the CM and LM spacecraft ECS's had overpressure protective devices, a PGA relief valve was not desired when the PGA was connected to them. Also, a differential-type pressure gage replaced the previously used ambient-reference-type gage to permit both sea-level and low-ambient-pressure readouts. A requirement to permit the crewman to self-administer a medical injection while wearing the PGA was met by the addition of a self-sealing patch on the right thigh.

During the time when qualification testing of the A6L PGA incorporating the above changes was underway, the Apollo spacecraft 204 accident at the NASA John F. Kennedy Space Center occurred. As a result of this accident, a major redesign of the PGA incorporated nonflammable materials and protective features wherever possible.

Thermal micrometeorite protective cover layer: The need for an outer PGA cover layer was established early in the development program. Puncture and abrasion protection for the basic TLSA pressure and restraint layers and thermal and micrometeorite protection during EVA's on the lunar surface or in free space were required. The initial A6L cover layer design consisted of a separate jacket and a pair of trousers made from multilayer thermal insulating materials like those of the Gemini G-4C space suit. The materials cross section consisted of alternate layers of perforated aluminized Mylar film, marquisette, and nonwoven Dacron sandwiched between a high-temperature-resistant outer layer of Nomex fabric and an inner layer of neoprene-coated ripstop nylon fabric. The separate jacket and trousers were to be donned and doffed over the basic PGA during flight.

To provide complete flammability protection at all times in the mission when the PGA was worn, the separate jacket and trousers design was changed to an integrated cover layer design approach, which led to the ITMG. After extensive materials evaluations and testing, the materials cross section was changed to use a nonflammable outer layer of Teflon-coated Beta cloth. The multilayer thermal insulating materials were changed to seven layers of gridded Kapton film separated by six layers of Beta marquisette and an inner layer of neoprene-coated ripstop nylon. Flaps were added to cover all exposed areas of the PGA such as the pressure sealing closure and the hardware-to-softgoods interfaces. Nonflammable Velcro fastener material was used to keep these flaps closed. A patch of Chromel-R woven stainless steel cloth was added on the back of the cover layer to provide higher abrasion resistance at the PLSS contact surface. This design was found satisfactory and was selected for use on the Apollo 7 mission. The EV gloves and lunar boot materials were also changed to incorporate nonflammable materials selected for the ITMG.

Electrical harnesses: The A6L PGA electrical harnesses initially used the same construction techniques that were used for the Gemini space suit. Individual wires were molded in a flat belt of silicone rubber. The wiring between the electrical connectors was covered with nylon cloth.

An exhaustive study and development program was initiated to determine and subsequently eliminate any possible ignition sources in the PGA. The harness was required to operate in a high-oxygen environment and in proximity to the cotton CWG material without posing any hazard of self-ignition or of igniting the cotton material under any combination of failure conditions, both in the PGA and in the Apollo spacecraft. Failures of this type included a short circuit of the current-limiting resistors in the spacecraft wiring in conjunction with a fault of the two power wires in the PGA electrical harness.

A method was developed for constructing the entire harness by braiding twisted shielded pairs. This procedure produced a harness with excellent flexibility in two axes, as opposed to the one-axis flexibility of the silicone belt, and with a tensile strength greater than the sum of the tensile strengths of the individual wire conductors. To further increase the durability, the primary conductors were constructed of Copperply, a copper-plated steel material with approximately 30 percent of the conductivity of copper. The superior strength of this material permitted the use of a smaller wire size, which increased the flexibility and retained the required tensile strength. At the same time, the higher electrical resistance of this wire, because of the small size and higher resistivity, caused fusion at far lower currents during

electrical overload, permitting the use of a minimum-weight cover material. Teflon-coated Beta cloth was initially used as the protective cover but was subsequently replaced by T-162 Teflon cloth when the Teflon-coated Beta cloth proved susceptible to wear and frequent patching or replacement.

Other changes made to the PGA included replacement of the polyurethane boot sole material with a less flammable silicone material and finally with a nonflammable molded Fluorel rubber, replacement of polycarbonate plastic actuation tabs on connectors and disconnects with aluminum tabs, addition of redundant locking features to all pressure integrity connectors and to the pressure sealing closure, covering of the polyurethane foam vent pad in the helmet with metal foil and a hydroformed aluminum cover, and addition of a Fluorel rubber coating to the IV pressure glove bladder.

While the redesign to incorporate nonflammable materials was being accomplished, the crewmen selected to fly the first orbital mission, Apollo 7, were provided with modified A6L training PGA's. During training in the CM simulator, the Apollo 7 crewmen experienced difficulty in operating controls required to safely reenter the Earth atmosphere in a contingency mode with the spacecraft decompressed. This problem was caused by the excessive upper arm and shoulder widths of the PGA's resulting in interference when all three crewmen were lying side by side in the couches. To alleviate this problem, the arms of the PGA's were changed to replace the arm rotational bearings with a newly designed elbow convolute having a nylon net restraint. Arm mobility was reduced as a result of this change, but because the initial Apollo missions did not require EVA or a high degree of pressurized PGA mobility, arm mobility was found acceptable.

During this period, problems with materials and molding techniques were encountered in the manufacture of the bubble-shaped helmet. Special molding techniques using temperature and pressure were developed to ensure an even thickness throughout the shell of the helmet and to provide good optical characteristics. Only the highest grade polycarbonate raw materials available were used; however, a high rejection rate resulted because of dirt inclusion. Also, the attachment of the polycarbonate shell to the helmet-half neckring by adhesive bonding was made stronger and more impact resistant by the addition of machined, bayonet-type mating grooves that provided a mechanical interface. To allow drinking water and food probes to be inserted into the helmet without losing pressurization, an aluminum feedport was added on the left side. A purge valve that also plugged into this feedport was evaluated but was found to be too difficult to operate because of visibility and arm reach limitations. For this reason, and to alleviate the need for a complex interface with the EVVA, the purge valve was redesigned to plug into an outlet gas connector, which was satisfactory.

Long sleeves were incorporated in the LCG to increase metabolic heat removal capacity and to provide lower arm cooling. A zipper was added in the crotch area to provide an opening for body waste management. Also, noncollapsible silicone rubber riser tubes were provided between the LCG manifold and the LCG multiple water connector, and aluminum fittings were incorporated at the LCG manifold and riser tube junctions. These changes were effected to prevent collapsing of the riser tubes, which would result in blockage and loss of cooling. Because of the extensive nature of these redesigns, the resultant PGA model was designated the A7L PGA.

The A7L PGA model .- The A7L PGA represented the final design model for the Apollo 7 to 14 missions. Changes and improvements resulting from qualification testing and crew evaluation during the initial orbital flights were incorporated into the Apollo 11 configuration previously described in this report. Significant improvements or changes to the A7L PGA made between the Apollo 7 and 14 missions are described in the following sections.

The IV PGA for the CMP: To save weight and reduce the bulkiness of the PGA worn by the CMP, who was not required to perform EVA, an IV version of the A7L EV PGA was developed. This IV PGA consisted basically of an EV PGA with features removed that were not required. The ITMG was replaced by a lighter weight cover layer; one set of gas connectors, the LCG water connector, and the PLSS interfacing attachment features were omitted from the IV design. Because the Apollo 8 mission did not require EVA capability, all three crewmen were provided an IV PGA. The CMP for the Apollo 9 to 14 missions was provided with the IV PGA.

The EVVA: The EVVA used on the Apollo 9 mission was designed to attenuate light and heat energy, to protect the pressure helmet from accidental impact, and to provide a nearly unobstructed and undistorted field of vision. Light seals, located along the lower rim of the protective visor and the upper rim of the Sun visor, were used to prevent any leakage of light or ultraviolet rays between the two visor assemblies and the shell assembly. A collar constructed from ITMG materials was attached around the base of the EVVA to provide thermal and micrometeoroid protection for the EVVA/PGA interface area. Thermal insulation for the helmet was contained under the EVVA shell. The visor assemblies, the pivot mechanisms, the collar assembly, and the latching mechanism were attached to a polycarbonate shell assembly.

The protective visor, a transparent, ultraviolet-stabilized polycarbonate shield, provided impact protection to the PGA helmet and thermal insulation during dark/cold environmental operations. The Sun visor provided ultraviolet absorption and was coated to provide light attenuation and to minimize heat leak into the helmet. Both visors were made of polycarbonate plastic and were molded by techniques used for the pressure helmet shell. Each visor could be positioned up or down as required by the crewman. The pivot mechanisms, located on each side of the EVVA shell, were support and pivot devices for the protective visor and the Sun visor. An attachment and lock mechanism allowed the lower rim of the EVVA to be tightened around the bottom of the pressure helmet for positive retention.

The LEVA: The LEVA used for the Apollo 11 to 17 missions incorporated improvements required as a result of thermal qualification testing and of an increase in the anticipated lunar surface temperature environment. These changes included the following improvements.

1. Increased protection from ultraviolet radiation and greater thermal stability was accomplished by replacing the polycarbonate Sun visor with a polysulphone Sun visor that had a higher temperature limit and greater ultraviolet absorption.
2. Increased protection was provided for thermal-optical coatings on the visors. The EVVA Sun-visor coating, required to reduce the environmental temperatures of the plastic to acceptable values, was vacuum deposited on the visor outer surface and

basically unprotected. Accidental coating removal during handling and use, regardless of the care taken, resulted in the need to coat the inner surface of the LEVA Sun visor instead of the outer surface.

3. Increased protection for the visors was provided by enlarging the shell to allow the visors to ride inside rather than outside as on the EVVA.

4. The addition of sunshades (on each side) improved visibility for normal operations on the lunar surface. These sunshades were constructed of fiberglass and coated on the outer surfaces with white paint and on the inner surfaces with black enamel. The sunshades were attached to the visor pivot mechanism and could be lowered independently of the Sun visor and of each other to prevent light penetration of the side-viewing areas, thereby reducing low-angle solar glare.

The LEVA worn on the Apollo 11 mission was improved for the Apollo 12 mission and incorporated the following changes.

1. Improved clearances throughout the assembly (visor/visor, visor/shell, visor/helmet)

2. Improved Sun-visor optics using a high-grade polysulphone material

3. Improved remote control unit (RCU) visibility by optimizing the tab locations, tab shelf distances, light seals, and thermal collar to enhance this critical interface

4. Improved pivot mechanisms that allowed more precise torque adjustment for visor actuating force

5. Improved sunshade design for ease of operation of the blinders with the Sun visor in the raised position, which was needed for looking into shadows at right angles to the Sun

The LEVA was modified for the Apollo 14 to 17 missions to incorporate a center eyeshade, recommended by the Apollo 12 crew. This center eyeshade consisted of an integral hinged-door mechanism positioned by the action of a ratchet device. The eyeshade reduced glare when walking toward the Sun during low-Sun-angle conditions. This configuration was satisfactorily used on all subsequent Apollo missions.

Arm mobility: After the arm bearings were omitted from the A7L PGA's before the Apollo 7 mission, development was implemented to provide the increased arm and shoulder mobility that was necessary for lunar surface work tasks. This development resulted in the design of a low-profile arm bearing that minimized CM couch interface problems. This design was evaluated by the Apollo 11 EVA crewmen and found to be a considerable improvement over the existent flight configuration. The low-profile arm bearings were incorporated into the A7L EV PGA and successfully used on the Apollo 11 and subsequent missions.

Materials durability: The gridded Kapton film used in the multilayer thermal insulation of the ITMG had very low tear strength. Also, during manufacturing, the Beta marquisette spacer material caused numerous problems in handling, cutting, shaping, and edgelocking. To solve these problems, the materials cross section was

modified for the A7L EV PGA's used on the Apollo 10 to 14 missions to incorporate two layers of Kapton film laminated to Beta marquisette and five layers of perforated Mylar film interspersed with four Dacron spacer layers. The laminated Kapton and Beta marquisette eliminated the handling problems, and the Mylar film, a stronger material than the Kapton, increased durability. The two layers of the Kapton film were retained for flame impingement protection. To improve abrasion resistance, external scuff patches of Teflon fabric were attached to the knee, waist, elbow, and shoulder areas. Mobility relief was designed into the knee, elbow, shoulder, and waist areas to reduce restrictions.

The redesigned ITMG satisfactorily accomplished the design objectives and was successfully used during the Apollo 11, 12, and 14 lunar surface EVA's.

Dual-flow purge valve: Before the Apollo 14 mission, the purge valve, used in conjunction with the OPS to provide for an open-loop-type EMU pressurization and ventilation, was redesigned to provide two positions for flow. A lower flow mode with a 1.8-kg/hr (4 lb/hr) rate was added to increase the operating time of the OPS when used in conjunction with the BSLSS, described later in this report.

The A7LB PGA model .- Additional requirements for the Apollo 15 to 17 missions resulted in redesign of both the A7L EV PGA and IV PGA configurations. These additional requirements included an increase in the number of lunar surface EVA periods to three and an increase in the time of each EVA to 8 hours. The LRV became available for these missions, which added the requirement for waist mobility to enable crewmen to get on, drive, and get off the vehicle. Also, the CMP was required to perform an EVA during the return to Earth to retrieve film packages from a camera located in the service module of the Apollo spacecraft. Significant changes incorporated into the A7LB PGA's and the problems encountered are described in the following paragraphs.

The A7LB PGA for the CMP: The configuration of the A7LB CMP PGA, selected to provide a 1-hour EVA capability, was essentially the same as the A7L EV PGA with improvements resulting from previous mission experiences; it was designed to maintain as much commonality as possible with the A7LB EV PGA's used by the CDR and the LMP. Major changes included incorporation of more durable and abrasion-resistant TLSA arms and legs, which were standardized for both PGA configurations; redesign of the pressure relief valve with a flow capability of 5.53 kilograms (12.2 pounds) of oxygen per hour, which was the maximum flow of the CM ECS life-support umbilical; replacement of the Teflon-coated Beta cloth outer layer of the ITMG with a more abrasion-resistant woven Teflon fabric; and the addition of a PCV that plugged into a gas connector to maintain pressure in conjunction with the CM ECS umbilical.

The CMP was provided EV gloves and used one of the other crewmen's LEVA's that had been brought back from the lunar surface. The Apollo 15 to 17 CMP's successfully completed EVA's and returned the film packages with no major problems.

The A7LB PGA for the CDR and the LMP: The A7LB EV PGA worn by the CDR and the LMP for lunar surface exploration incorporated redesigns to permit waist mobility not available in the A7L EV PGA. The A7LB EV PGA also had a reinforced and more durable pressure bladder.

The waist convolute joint provided increased waist mobility in forward, backward, and side-to-side directions. Incorporation of the waist convolute into the A7LB PGA precluded the use of the A7L-type rear vertical entry closure, and hardware location and donning problems precluded the use of a horizontal closure. Therefore, a new entry closure was provided that extended from the upper right front side near the torso/neck interface to under the right arm, passed diagonally across the back, and ended at the lower left front side. Gas sealing was accomplished by a Talon omnienvironmental-barrier (OEB) type pressure-seal closure located inside a load-carrying restraint zipper.

The A7LB EV PGA also incorporated a neck convolute to provide both forward and backward neck mobility. This feature not only allowed variations in head position but also improved crewman visibility for LRV driving. A neck convolute restraint cable system provided convolute adjustment capability to accommodate variations in crewman head and neck height. To increase the durability and abrasion resistance of the pressure bladder, a nylon-cloth scuff layer was bonded to the entire inner surface of the nylon-coated neoprene bladder, the joint convolutes, and the boot bladder.

Other changes incorporated in the A7LB EV PGA's were the addition of hinged pulleys at the ends of the shoulder joint cable guides, which reduced torque; an increase in the diameter of the glove wrist disconnects to provide for easier donning and greater wrist comfort; an improved glove bladder assembly to provide increased thumb dexterity, comfort, and hand-clenching capability; and a redesigned pressure relief valve incorporating a manual override cap with an increased flow capability of 5.53 kg/hr (12.2 lb/hr).

Communications Carrier Assembly

The personal communications equipment for the suited mode of operations was designed into the helmet for Mercury, Gemini, and early prototype Apollo space suits. With the advent of the AX5L bubble helmet, it became necessary to remove the communications equipment (microphones, earphones, and related electrical harness) from the helmet and to affix the equipment directly on the crewman's head. This device, originally intended to provide for communications when the helmet was not worn, was known as the communications carrier (fig. 31).

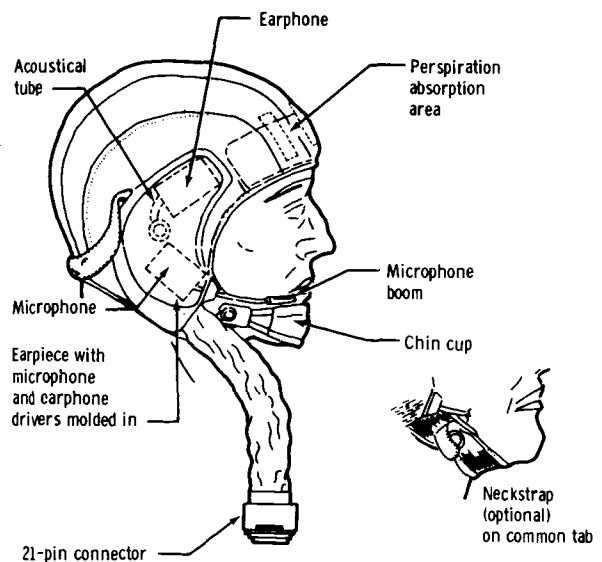

Figure 31. - Communications carrier.

The initial design of the communications carrier incorporated microphones and earphones contained in plastic earcups. The earcups were covered with nylon fabric and suspended from a strap arrangement that held them on the head.

Through tests and training exercises, it became apparent that the following basic problems required correction.

1. The strap arrangement did not hold the communications carrier adequately in position on the head.
2. The suppressor circuit produced unacceptable intelligibility.
3. The 30-decibel isolation provided by the polycarbonate earcups was not sufficient. Testing showed that a level of approximately 50 to 60 decibels was necessary.
4. The brittle plastic (diallyl phthalate) of the electrical connector was easily damaged.

Because of these problems, a complete redesign was implemented. The effort included the following major changes:

1. The strap-suspension system was changed to a skullcap, and the ear seals were changed from plastic to deerskin-leather-covered foam inserts.
2. The noise-suppressor configuration was eliminated.
3. The microphone and earphone modules were molded into silicone rubber earcups.
4. The electrical connector was changed to an identical type made of polycarbonate.

The only other change made was in the procurement of new microphones and earphones. The microphone power leads were shielded. Communications carriers with this shielding were required for PLSS operation because of the proximity to the PLSS antenna. Further attempts to improve the radiofrequency interference susceptibility by double shielding the microphone wires were unsuccessful. The configuration resulting from this redesign proved acceptable for all the Apollo missions.

Bioinstrumentation System

The development of bioinstrumentation and related hardware was primarily program or mission oriented and was directed toward fulfilling one or more of the following objectives: operational in-flight safety monitoring, in-flight medical experiments, or safety monitoring during ground-based operations.

The bioinstrumentation system (fig. 32) consists of one electrocardiograph (ECG) signal conditioner, one impedance pneumograph (ZPN) signal conditioner, one direct current (dc)/dc converter, one sternal electrode harness, and one axillary electrode harness.

The ECG signal conditioner with associated electrodes is designed to provide in-flight measurements of crewmembers' ECG activity and to develop a signal wave ranging between 0 and 5 volts peak-to-peak, which is representative of crewman ECG activity. The unit is provided with a device that permits preflight gain adjustments.

The ZPN signal conditioner and associated electrodes are designed for measurement of a change in the transthoracic impedance to a low-level current at a frequency of approximately 50 kilohertz. Measurement is obtained from a pair of appropriately placed electrodes that present a changing impedance to a signal conditioner, which in turn develops signals (0 to 5 volts peak to peak) corresponding to the respiration rate over a wide dynamic range of respiratory activity of the crewman or test subject. This

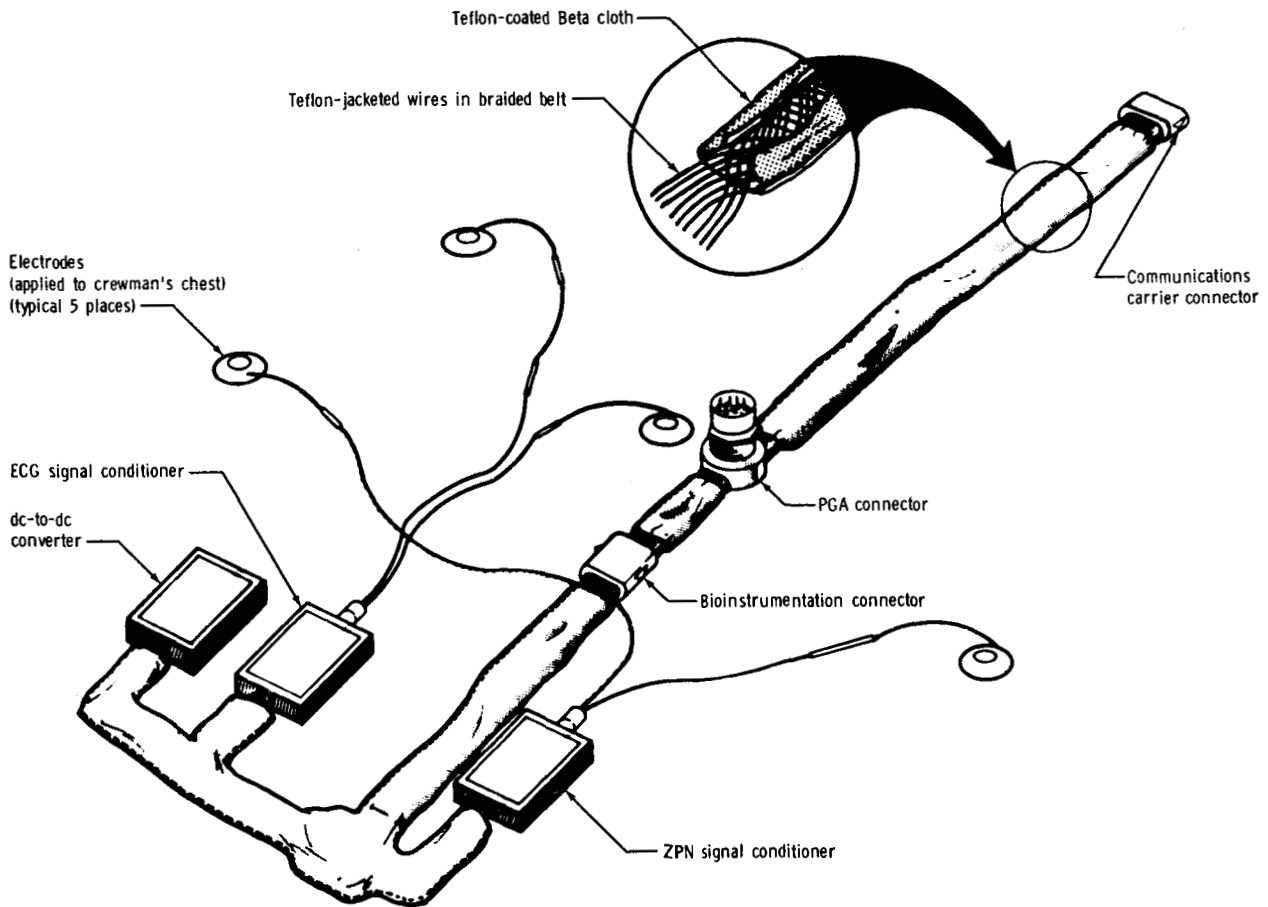

Figure 32. - Bioinstrumentation system.

unit is provided with controls that permit preflight adjustments of circuit gain to accommodate the characteristics of the individual.

The dc/dc power converter is a component of the bioinstrumentation system that delivers the regulated positive 10-volt and negative 10-volt power to each signal conditioner. The converter is powered from the unipolar nominal 16.8 volts available for suit electronic equipment. The converter converts 16.8 volts to the isolated and balanced bipolar supply required by the bioinstrumentation system. The design characteristics incorporate features for reverse-polarity protection, for load-current limiting, and for electrical isolation of the input and output ground systems. The ECG and ZPN signal conditioners and the dc/dc converter are worn in a pocket attached to the CWG or LCG.

The axillary electrode harness, a small cable used in conjunction with the ZPN signal conditioner, provides the interface between the crewman and the ZPN signal conditioner. The sternal electrode harness, a small cable used in conjunction with the ECG signal conditioner, provides the electrical interface with the crewman and provides a system ground electrode, which is a high-impedance ground used primarily to remove the static charge on the test subject.

The system to be used inside the PGA was the result of various trade-off considerations. Although comfort problems exist if the system is placed inside the suit, these problems are more than offset by the improved signal-to-noise ratio obtained and the electrical isolation provided by the signal conditioners that afford maximum protection against accidental shock. Another reason for having the system located in the space suit is that the gain settings for each crewman are different, and having one centrally located set of instrumentation would cause additional switching problems in the low-level signal lines.

The system, as designed, has provided satisfactory and useful data for the space program but has not been completely free of either mechanical or electrical problems. The following paragraphs briefly summarize the problems that were encountered and their solutions.

The first problem encountered was one of determining whether or not a fire hazard existed inside the PGA. Considerable testing revealed that a spark produced by short circuiting the output leads of the dc/dc converter would ignite cotton in an environment of 131 kN/m^2 (19 psia) oxygen. This ignition source was traced to energy storage in the output capacitors in the dc/dc power converter and to the capability of the converter to produce a high-current, short-duration pulse in a short-circuit condition, even though the output current is limited to 50 milliamperes in a steady-state condition. This high-current pulse and the associated ignition hazard were eliminated by the installation of current-limiting resistors in the positive 10-volt and negative 10-volt output leads of the dc/dc converter.

The next major problem occurred during the first manned Apollo flight (Apollo 7) when the single-pin disconnects in both electrode harnesses separated inside the PGA. Data were lost until the suit was removed and the connection remade. Lead breakage occurred at the connectors of the electrode harnesses, which added to the overall

problem experienced on this flight. Also during the Apollo 7 mission, one of the crewmen reported that he had a hot signal conditioner. On receiving this information, the Mission Control Center (MCC) instructed the crewman to remove and stow the biomedical hardware.

The solutions to these problems did not come quickly. First, the electrode harness was redesigned to eliminate the pin disconnect that came loose during flight. Later electrodes were wired as a permanent part of the harnesses, which were also custom fitted to the crewman. A series of meetings was held to review test results on various materials and their application in the solution of the fatigue problem. As a result, the wire insulation was changed from Teflon to PVC, and the strain relief boot, from epoxy to silicone rubber. Subsequent qualification tests showed this combination to be considerably better than the original concept.

An investigation of the hot-signal-conditioner problem revealed that the dc/dc converter ran warm to the touch under normal operation and could be uncomfortably hot if a short circuit of the series voltage-dropping resistor in the spacecraft occurred with resultant application of 30 volts to the dc/dc converter. The converter was not redesigned, but crews were briefed before flight on what to expect under normal and abnormal conditions. In addition, a temperature-recording label was affixed to each signal conditioner.

As a result of a continuing test effort, a sneak groundpath was discovered in the electrode leads into the ECG signal conditioner. This problem was solved by increasing the lead impedance with the addition of series current-limiting resistors to the sternal electrode harness. A ground electrode was also added to reduce noise and artifact on the ECG data. Again, a series resistor was used to provide current limiting.

The ECG and ZPN electrodes are silver/silver-chloride-anodized disks in an acrylic housing. The wiring is a highly flexible PVC-insulated cable with a silicone rubber bend relief at the connector.

The electrodes are filled with electrolyte (paste) and attached to the crewman with double-back adhesive tape. The electrode is then covered with a porous surgical tape that permits normal skin respiration. The electrochemical activity that occurs at the electrode surface is degraded if the anodization is damaged. This degradation occurs after many usage cycles. The problem could be eliminated by replacing the anodized disk with a pressed pellet of powdered silver and silver chloride. This change, which provided a homogeneous electrode that would not be affected by surface damage, was used in subsequent programs.

The attachment technique is limited by safety and comfort. The problem is to maintain contact while minimizing discomfort and skin damage. Because an electrode can be dislodged under a severe strain such as suit doffing and donning, a kit is provided for replacement of electrodes, if necessary, during unsuited periods.

DESCRIPTION OF THE PLSS AND THE OPS

To provide a suitable protective environment while outside the LM during both lunar surface and free-space excursions, the crewman carries on his back a compact assembly of various environmental control devices, which, when joined together, form the PLSS (fig. 33). The PLSS supplies breathing oxygen; controls suit pressure; reprocesses the recirculated oxygen by removing CO₂, odors, moisture, and some trace contaminant gases; controls temperature; provides warnings of certain system malfunctions; and provides voice communications and data telemetry.

The OPS, an emergency oxygen supply, is manually actuated when needed to supply breathing oxygen, to control suit pressure, to remove contaminants, or to cool

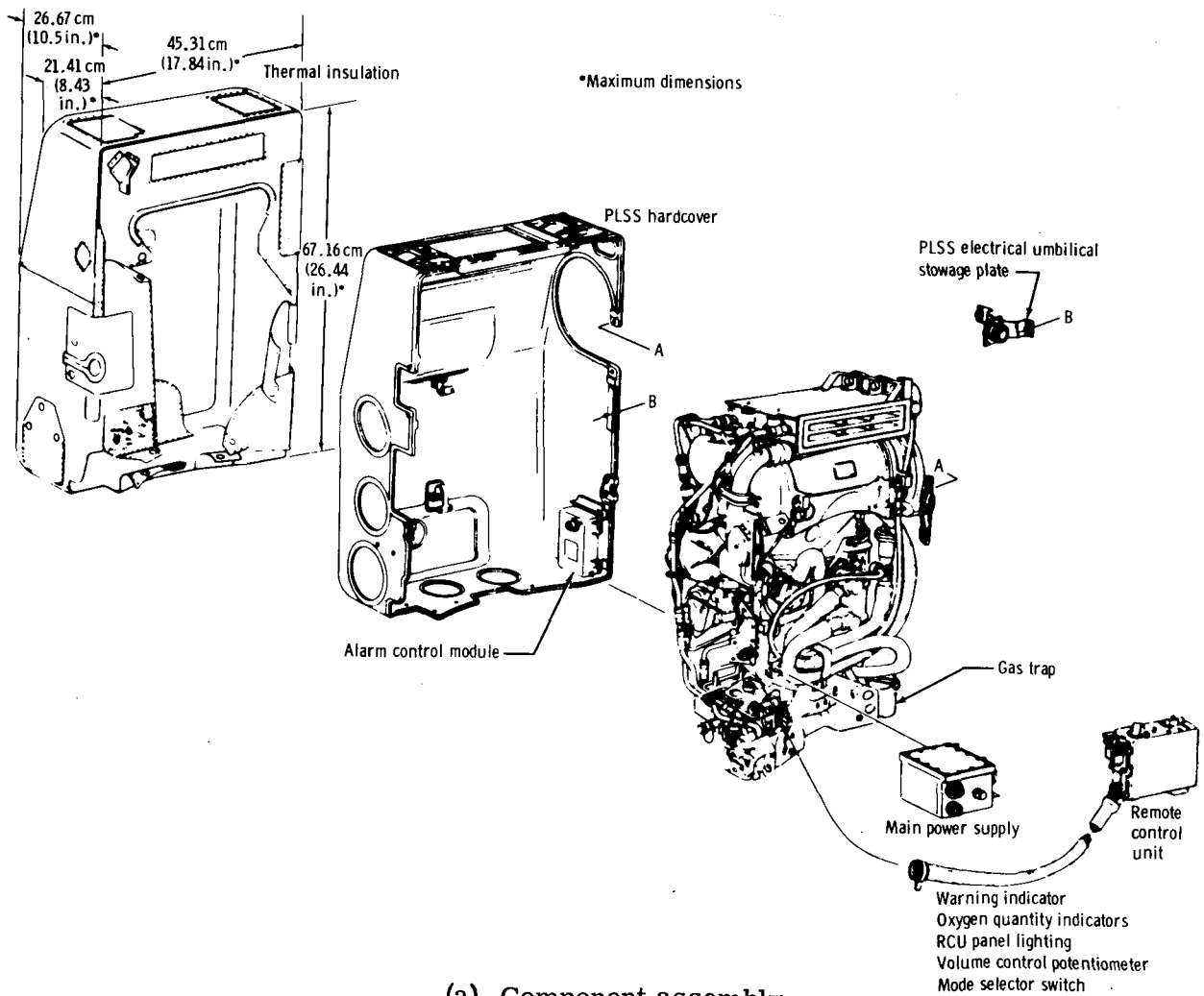

Figure 33. - Portable life-support system.

the crewman if these functions in the PLSS are impaired. A high oxygen flow is introduced directly into the oral-nasal area by suit ducting and is dumped overboard through a suit-mounted purge valve.

Multiple EVA's were planned for each mission; therefore, provisions were made for recharging or replacing the PLSS expendables (oxygen, water, contaminant-removal cartridges, and power supplies) from the LM. There was no requirement to recharge the OPS. The OPS was never used in an actual emergency during the Apollo Program.

Apollo 11 PLSS Configuration

The Apollo 11 PLSS (part number SV706100-6) consists of equipment necessary to support a crewman during EVA. The PLSS supplies oxygen to the PGA at a pressure

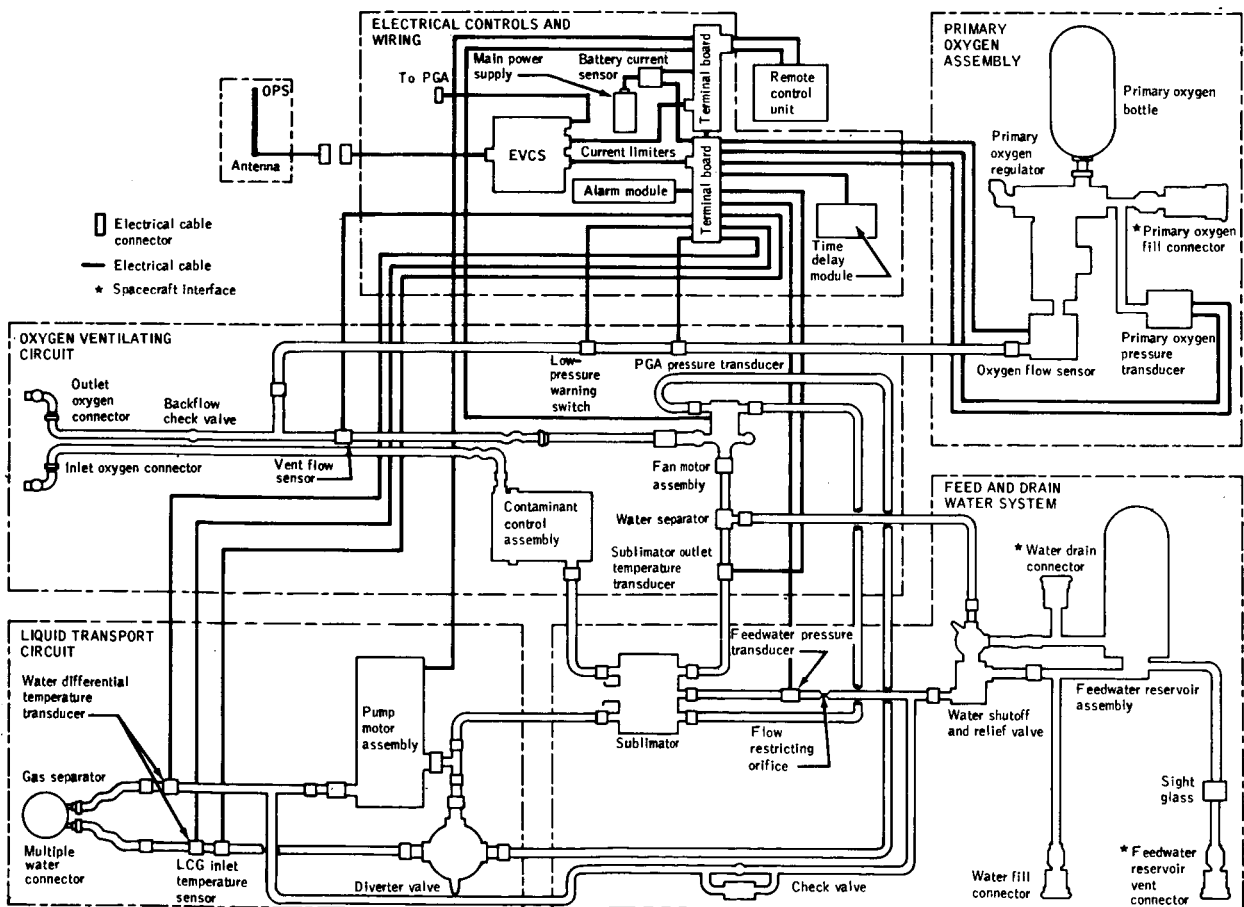

(b) Schematic diagram.

Figure 33. - Concluded.

of $26.4 \pm 1 \text{ kN/m}^2$ ($3.85 \pm 0.15 \text{ psid}$) and cooling water to the LCG at a minimum flow rate of 1.72 kg/min (3.8 lb/min). The PLSS is composed of the oxygen ventilating circuit, the primary oxygen subsystem, the liquid transport loop, the feedwater loop, and the electrical subsystem.

The oxygen ventilating circuit (fig. 34) provides temperature, humidity, and contaminant control of the recirculating breathing oxygen. Oxygen from the circuit enters the suit ventilation distribution system at a minimum flow of $0.156 \text{ m}^3/\text{min}$ (5.5 acfm) and absorbs heat, moisture, and metabolic byproduct contaminants as it passes through the suit adjacent to the crewman's body. The warm, moist, contaminated gas is then returned to the PLSS where it is transported to the contaminant control package, which consists of an activated charcoal bed that absorbs trace contaminant gases and an LiOH bed that reacts with CO_2 to form lithium carbonate. Byproducts of this chemical reaction, heat and moisture, are added to the heat and moisture already carried by the recirculating gas stream. The gas stream then enters the heat exchanger (sublimator) where the heat is given up, and the excess moisture in the stream is condensed. When it leaves the heat exchanger, the entrained free water is removed from the gas stream by an elbow wick-type water separator and transferred to the back side of the feedwater reservoir bladder. The temperature of the gas leaving the sublimator is telemetered

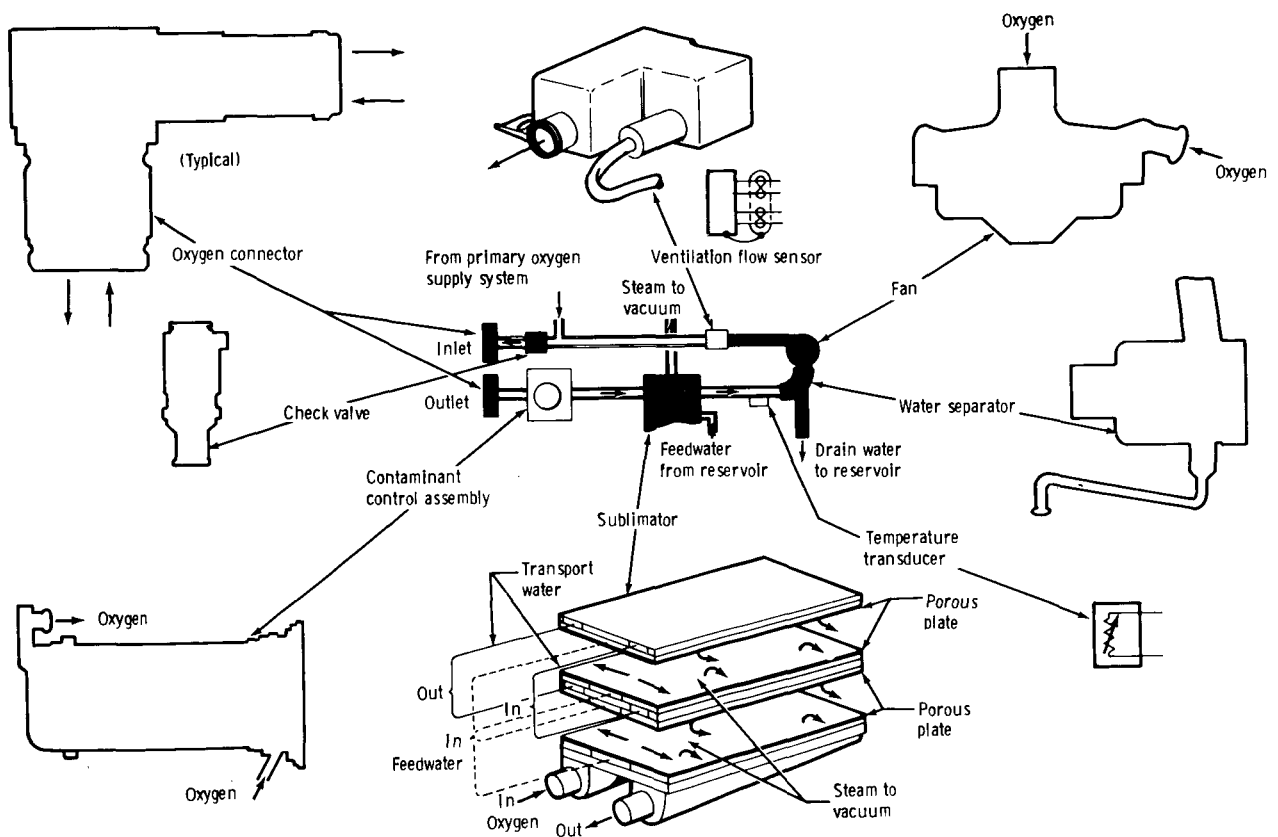

Figure 34. - Oxygen ventilating circuit schematic.

by the sublimator outlet gas temperature transducer. The stream then goes to a centrifugal fan driven by an electric motor and supplies the energy for overcoming the pressure drop in the EMU system. A ventilation flow sensor provides an input signal to the alarm module and to the RCU warning indicators when ventilation flow drops to between 0.113 and $0.150 \text{ m}^3/\text{min}$ (4.0 and 5.3 acfm). After passing through a backflow check valve, the cooled, dried, decontaminated gas is then returned to the suit for reuse.

The gaseous oxygen in the PLSS primary oxygen subsystem (fig. 35) regulates the oxygen pressure in the PLSS oxygen ventilating circuit to $26.5 \pm 1 \text{ kN/m}^2$ ($3.85 \pm 0.15 \text{ psid}$). Fully ground charged, the primary oxygen bottle contains 0.472 kilogram (1.04 pounds) of usable oxygen at $7033 \pm 69 \text{ kN/m}^2$ ($1020 \pm 10 \text{ psia}$) and 294 K (70° F). This amount supplies adequate makeup oxygen to satisfy a metabolic load of 352 watts

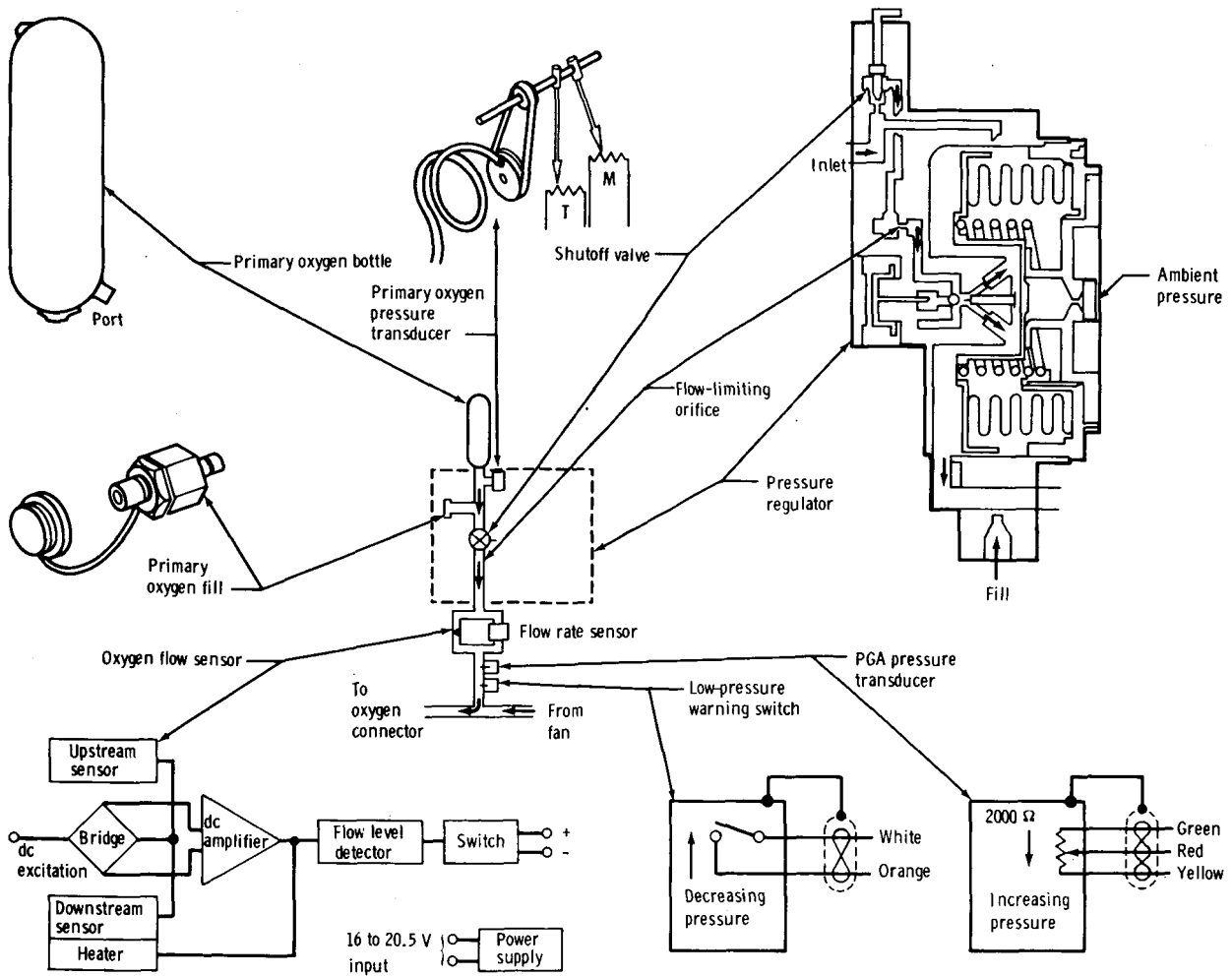

Figure 35. - Diagram of the primary oxygen subsystem.

(1200 Btu/hr) and a specified EMU leakage for 4 hours. High-pressure, corrosion-resistant steel tubes and fittings connect the primary oxygen bottle to the oxygen regulator assembly. The oxygen supply shutoff valve is actuated by an operating linkage at the lower right front corner of the donned PLSS. The oxygen shutoff valve is closed when the PLSS is not in use or when the primary oxygen subsystem is being charged.

The flow of oxygen through the regulator assembly is limited to a maximum of 1.63 kg/hr (3.6 lb/hr) with a full charge to protect the PGA against overpressurization in the event of a failed-open regulator. A self-sealing, quick-disconnect fill connector is used for recharging the primary oxygen subsystem. An oxygen flow sensor activates an audible tone when the PLSS primary oxygen usage exceeds 0.295 kg/hr (0.65 lb/hr) and is deactivated when oxygen makeup flow decreases to 0.23 kg/hr (0.5 lb/hr) or less. A primary oxygen pressure transducer provides electrical signals to the oxygen quantity display and to the telemetry system of the PLSS. Two additional pressure transducers in the primary oxygen subsystem monitor the PGA pressure. One transducer is used for telemetry monitoring, and the other activates an audible warning tone when the PGA pressure drops below 21 kN/m^2 (3.10 psid).

The liquid transport loop (fig. 36) is the primary means of thermal control of the crewman. Water from the LCG enters the loop through the multiple water connector and passes into a gas separator, where a 400-mesh semipermeable screen traps any free gas in the water to avoid cavitation in the pump. Excess separated gas can be

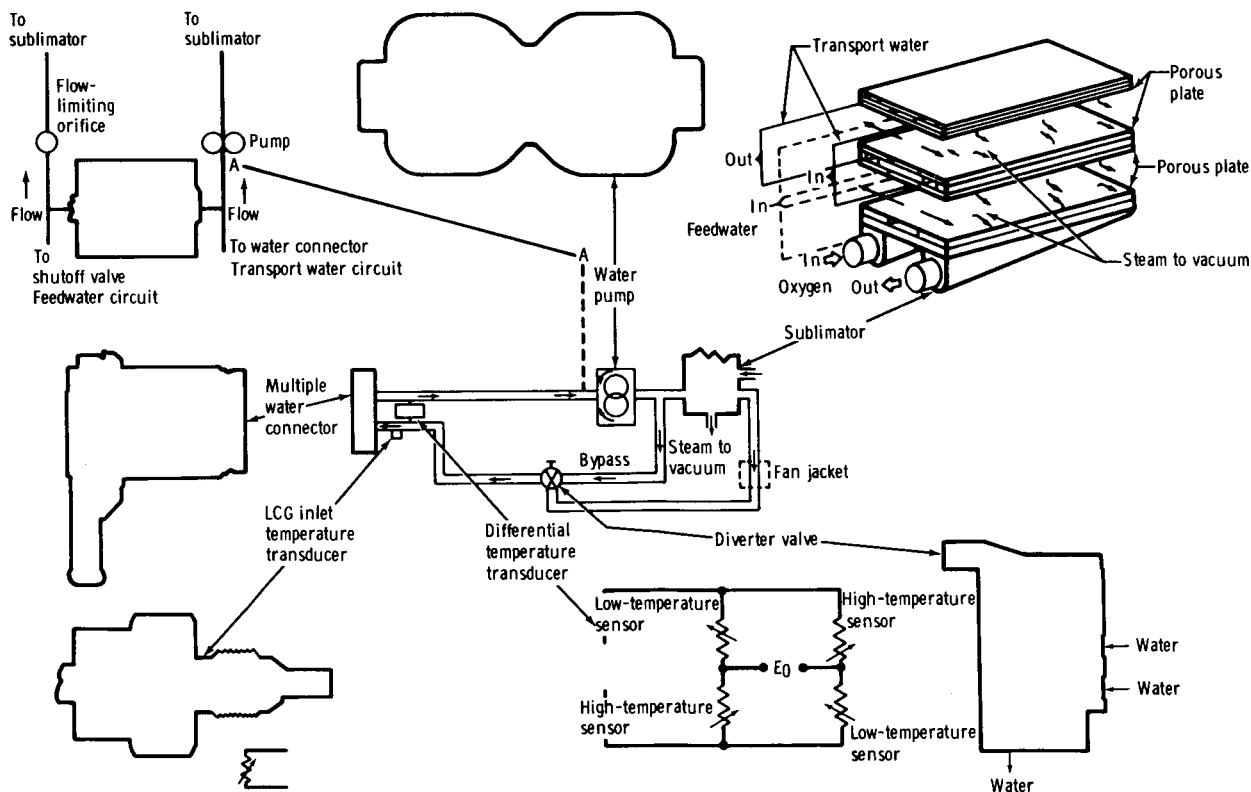

Figure 36. - Liquid transport loop schematic.

bled through a manually operated gas bleed port. From the gas separator, the water flows to the pump motor assembly, which creates a minimum pressure rise of 18.5 kN/m^2 (2.68 psi). The pump forces water through the transport water loop at a minimum flow rate of 1.72 kg/min (3.8 lb/min). In the sublimator, heat is transferred by the heat exchanger fins from the liquid transport loop to the feedwater loop. After passing through the sublimator, the cooled water circulates around the fan motor to cool the motor electronics. A check valve located between the feedwater loop and the liquid transport loop maintains a constant operating pressure on the pump. The coolant flow rate through the sublimator is regulated by the PLSS water diverter valve, which, in the minimum position, diverts the flow, allowing most of the water to bypass the sublimator before returning to the LCG. In the maximum valve position, all transport water flows through the sublimator; the intermediate position is a midpoint between the two extremes. The temperature difference between the water entering and leaving the water transport loop is sensed by a differential temperature transducer, and the output signal is telemetered. The actual temperature of the water leaving the PLSS is sensed by the LCG inlet temperature sensor and is carried on telemetry. The cooled water is finally returned to the LCG through the multiple water connector.

The PLSS feedwater loop (fig. 37) is rechargeable, supplies expendable water to the porous plate sublimator, and stores condensation removed by the water separator in a reservoir. The reservoir is a bladder-type rechargeable tank that provides a minimum of 3.81 kilograms (8.4 pounds) of expendable feedwater for sublimation. Water from the water separator is stored between the reservoir housing and bladder. The bladder contains a vent line for removal of entrapped gas to ensure a full charge. A manually operated water shutoff and relief valve allows feedwater to flow to the sublimator and, when closed, acts as pressure-relief protection against feedwater reservoir overpressurization. The combination of stored drain water pressure and oxygen ventilation loop pressure through the water shutoff valve pressurizes the feedwater bladder to 23 kN/m^2 (3.3 psid) minimum. A water fill connector and a water drain connector allow access to both sides of the reservoir bladder to facilitate recharge and drain. Because the reservoir contains a bladder, fill and drain operations are performed simultaneously. Recharge time from a 276 kN/m^2 (40 psid) source is less than 5 minutes. A pressure transducer provides system telemetry monitoring to identify sublimator breakthrough and low feedwater reservoir level.

The electrical power subsystem provides dc power through the appropriate connectors to the fan and motor assembly, the pump motor assembly, the communications system, and the instrumentation. The power is supplied by a $16.8 \pm 0.8 \text{ V}$ dc, 11-cell, silver zinc alkaline battery with a minimum capability of 59.8 kilocoulombs (21.4 A-h).

The extravehicular communications system (EVCS) provides voice communications and telemetry transmission of performance parameters. In detail, the capabilities include duplex voice communications and emergency communications between the spacecraft and the EV crewman, voice communications between the crewmembers, duplex voice communications between Earth and one or both crewmen, pulse amplitude modulation sampling of 30 channels at 1.5 samples/sec, simultaneous telemetry from two crewmembers, and audible alarm signaling in response to emergency conditions. The EVCS consists of two EV communicators that are integrated with the PLSS. The

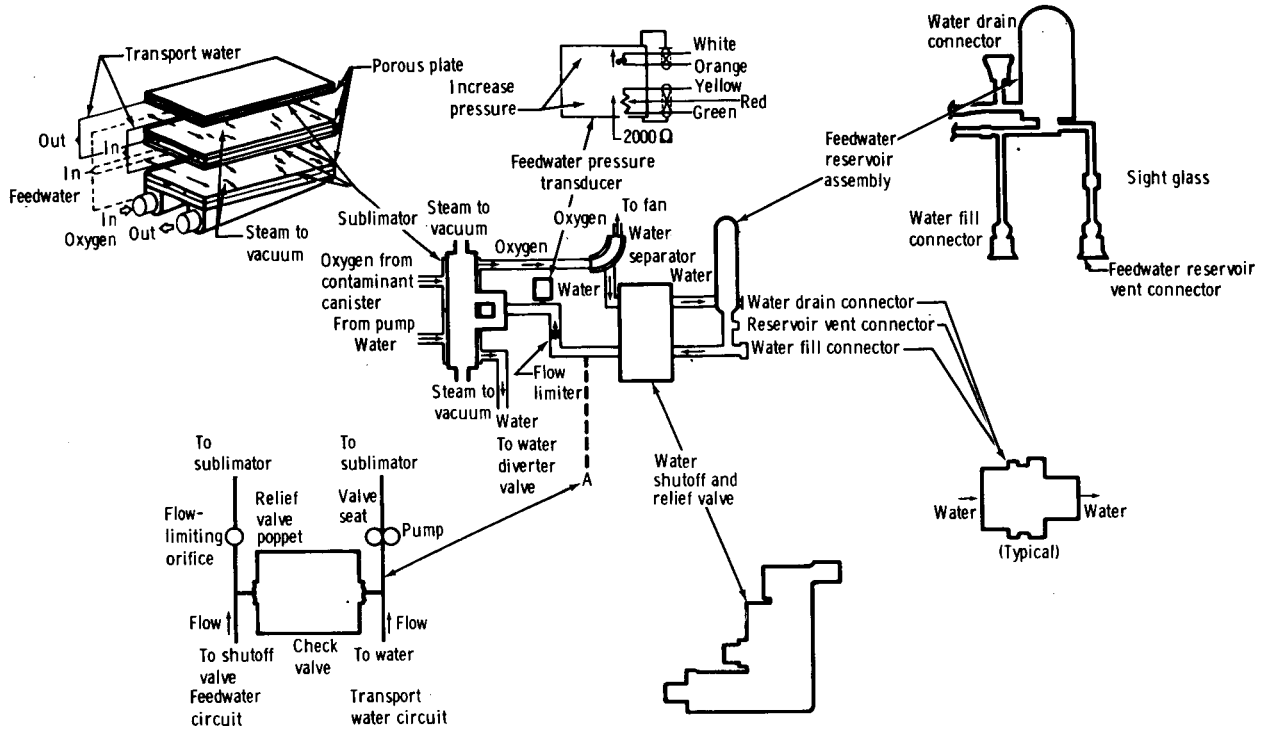

Figure 37. - Schematic of the PLSS feedwater loop.

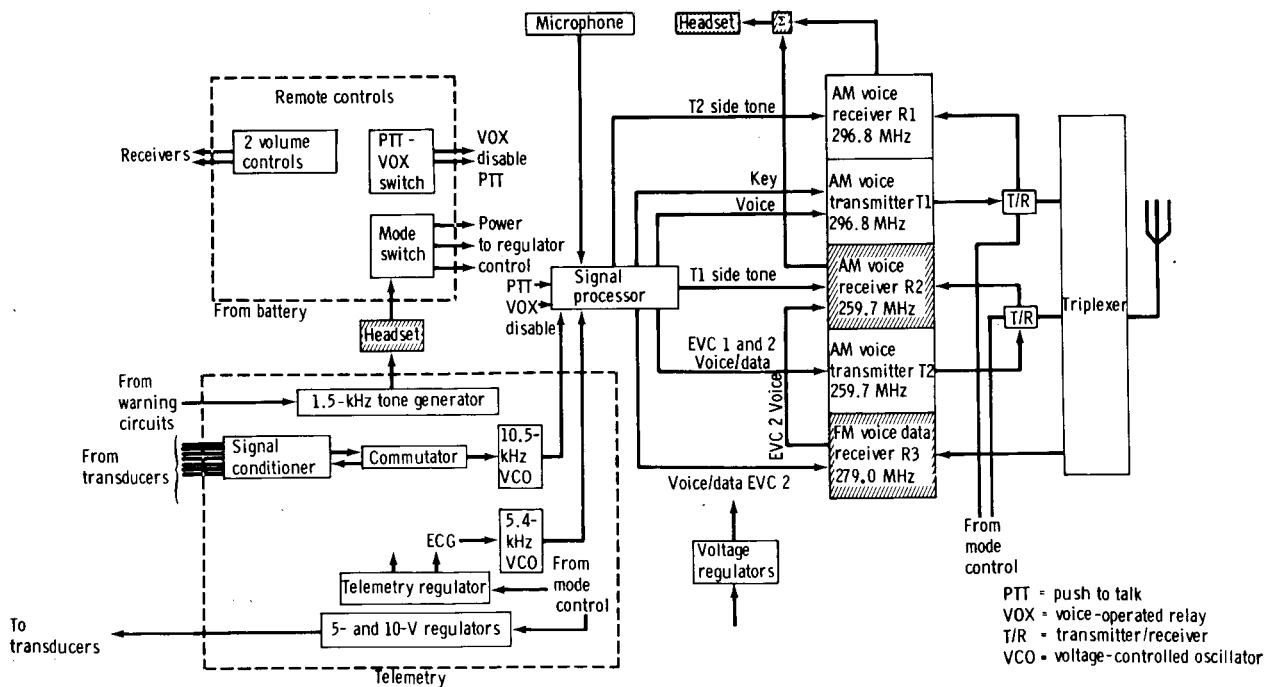

Figure 38. - Extravehicular communications system for EVC 1.

first EV communicator (EVC 1) (fig. 38) consists of two amplitude-modulated (AM) transmitters, two AM receivers, one frequency-modulated (FM) receiver, signal-conditioning circuits, a telemetry system, a warning system, and other components required for operation. The EVC 2 (fig. 39) is similar to the EVC 1 except that the EVC 2 has an FM transmitter instead of an FM receiver. The composite signal of voice and four subcarriers is relayed from the LM to the Earth by S-band, and the S-band communications signals from Earth are relayed to both crewmen through the LM.

The RCU (fig. 40), mounted on the chest of the PGA, houses electrical controls for the PLSS, the primary oxygen quantity indicator, and visual warning devices; the RCU also serves as an anchor point for a camera bracket and for the OPS actuator mechanism. The controls are the fan on/off switch, the pump on/off switch, the push-to-talk switch (which can override the voice-operated switch normally used in the communications system), the communications system volume control, and the communications system mode selector switch. An audible warning signal is given to the crewman if certain parameters fall outside desired limits, and visual identification of the problem and the required corrective action are given by small "flags" or indicators on the RCU. The parameters covered are low feedwater pressure, low ventilation flow, low PGA pressure, and high oxygen flow. The required corrective actions are mission abort and use of the OPS for purge flow or makeup flow.

Both the PLSS and the RCU are enclosed in hard covers for structural protection and in thermal covers for thermal protection.

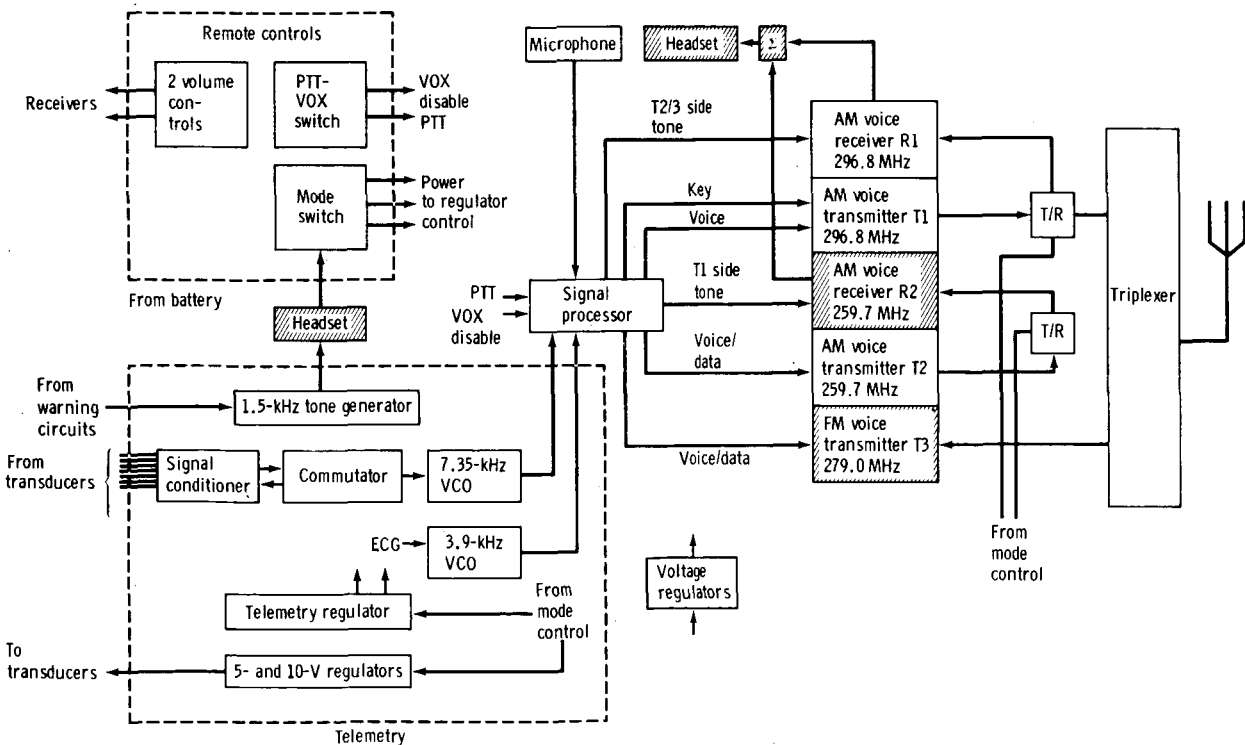

Figure 39. - Extravehicular communications system for EVC 2.

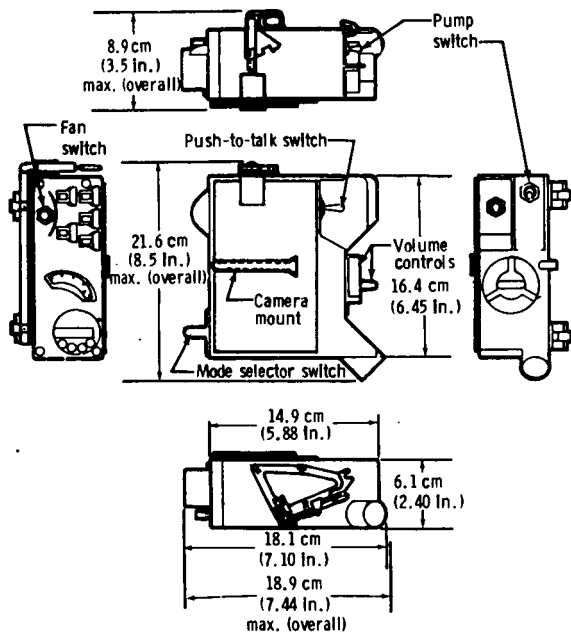

Figure 40. - Remote control unit.

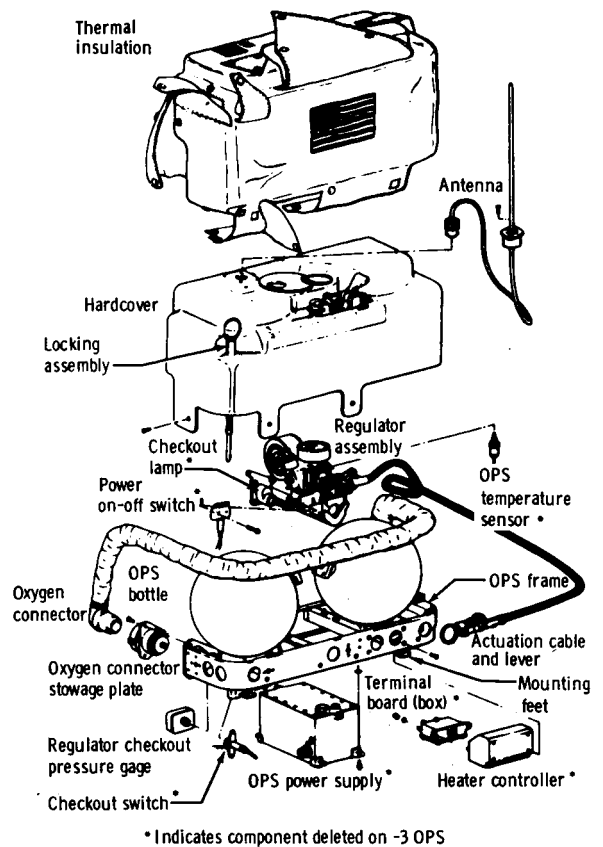
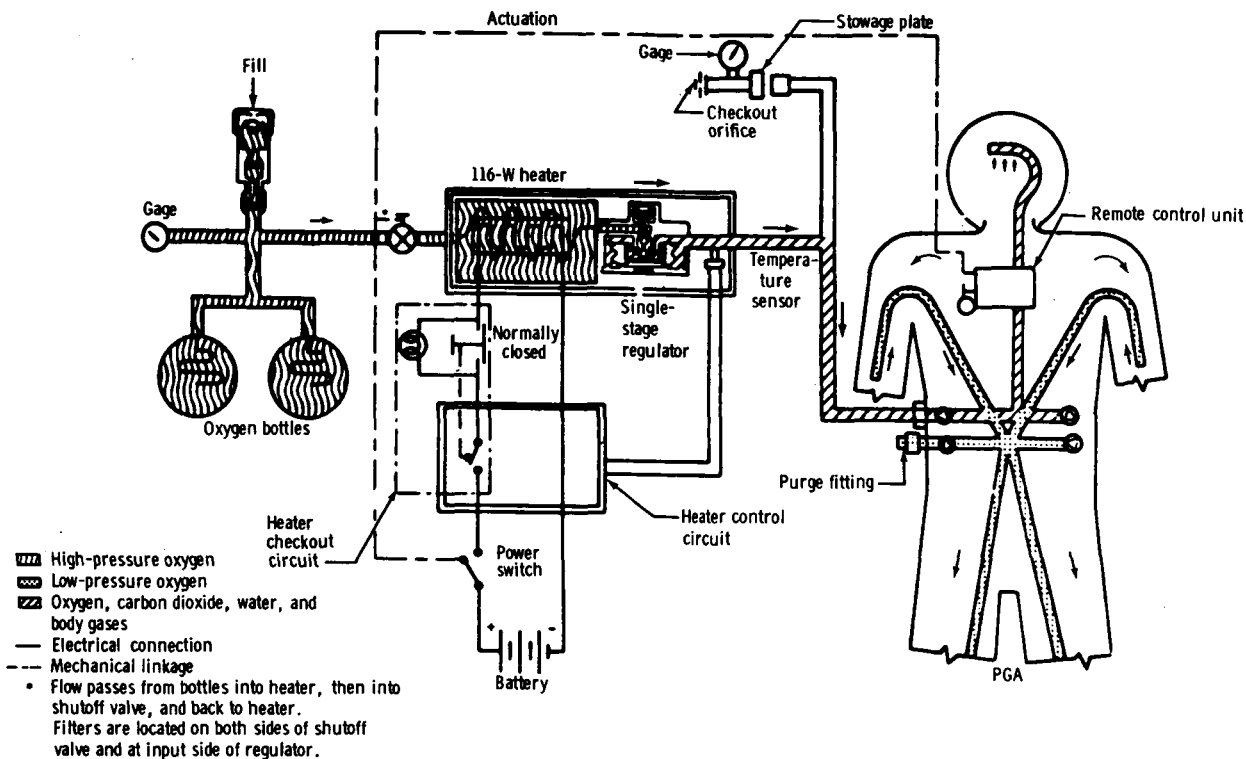

Figure 41. - Oxygen purge system components.

Apollo 11 OPS Configuration

The OPS configuration (part number SV730101-2) used for the Apollo 11 mission (figs. 41 and 42) provided the EMU with an oxygen supply and pressure control for certain failure modes of the PLSS or PGA during the EVA. In the normal EVA configuration, the OPS is mounted on top of the PLSS and is used only during emergency operations. In the contingency EV configuration, the OPS is attached to the PGA front lower torso and functions independently of the PLSS. The OPS is self-contained, independently powered, and nonrechargeable. The OPS provides a minimum of 30 minutes of regulated ($25.5 \pm 2 \text{ kN/m}^2$ ($3.7 \pm 0.3 \text{ psid}$)) purge flow at a nominal flow of 3.63 kg/hr (8 lb/hr) ($0.176 \text{ m}^3/\text{min}$ ($6.2 \text{ ft}^3/\text{min}$)) to prevent excessive CO_2 buildup and to provide limited cooling.

The high-pressure oxygen supply consists of two interconnected, spherical, high-pressure oxygen bottles (each with approximately 0.91 kilogram (2 pounds) of usable oxygen at $40\,540 \pm 3450 \text{ kN/m}^2$ ($5880 \pm 500 \text{ psig}$)), an automatic temperature control module, a pressure regulator, a battery, an oxygen connector, and the necessary checkout instrumentation. The OPS provides the hard mount for the PLSS very-high-frequency antenna.



(a) Purge mode.

Figure 42. - Oxygen purge system.

The OPS oxygen pressure regulator is a single-stage, variable-orifice regulator that keeps the PGA inlet oxygen pressure at $25.5 \pm 2 \text{ kN/m}^2$ ($3.7 \pm 0.3 \text{ psid}$). The regulator has an in-line electric heater and automatic temperature control module to maintain the normal PGA inlet oxygen temperature between 272 and 300 K (30° and 80° F). Power is supplied by a 27-volt battery. Both the regulator and the heater have preoperational checkout systems. The OPS pressure gage, used for both ground fill and preoperational checkout, monitors the source pressure of the interconnected OPS oxygen bottles. The OPS regulator pressure gage verifies regulated flow through a 0.032- to 0.163-kg/hr (0.07 to 0.36 lb/hr) orifice mounted on the stowage plate. A status check switch will, when actuated, illuminate a green light if the heating circuitry is functioning acceptably. During OPS usage, the outflow of oxygen from the suit is controlled by the suit-mounted oxygen purge valve (table III and figs. 24 and 25).

Apollo 15 PLSS and OPS Configurations

The SV706100-7 PLSS was used on the Apollo 15 to 17 missions. The PLSS had been modified to support longer lunar surface missions (as long as 8 hours). The extended capability was achieved by increasing the operating pressure level in the

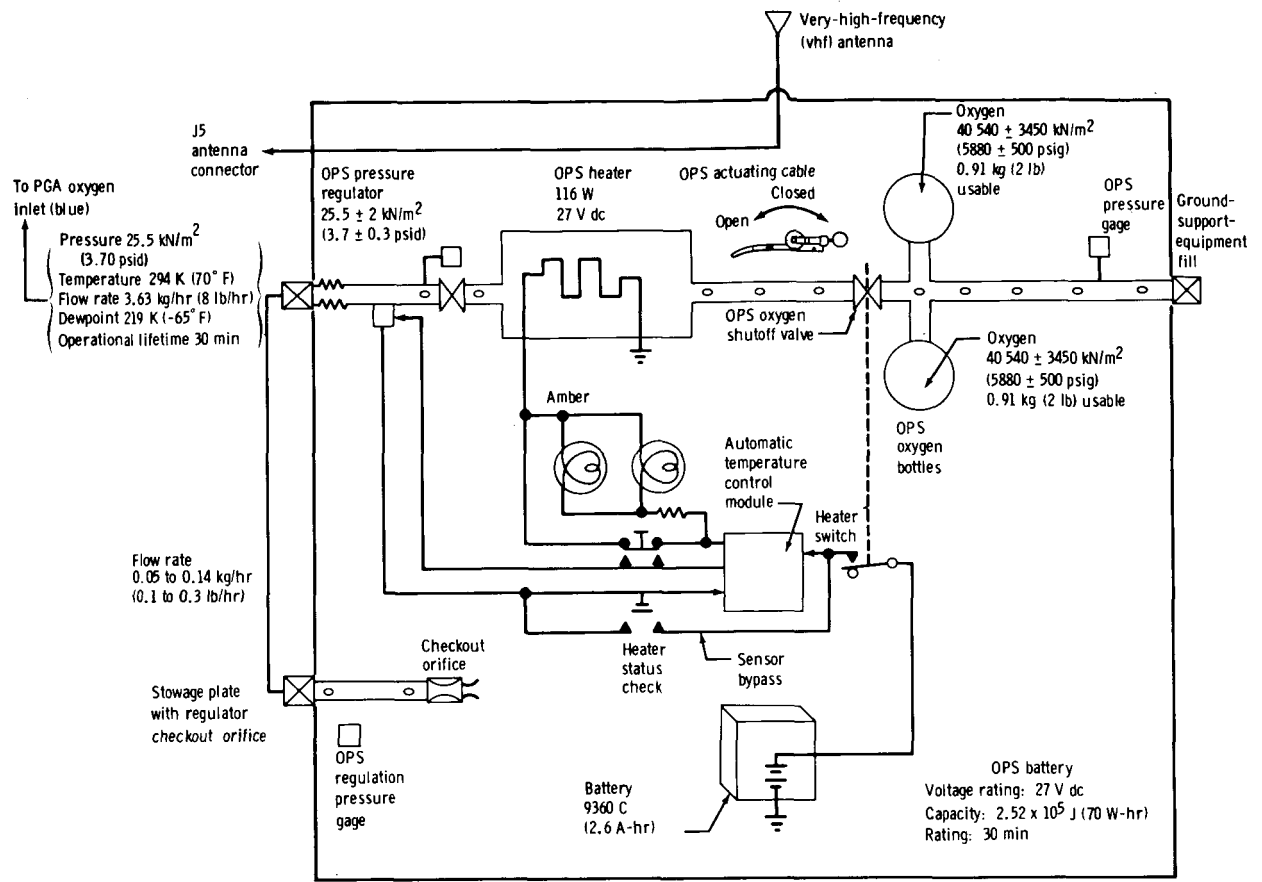

(b) Schematic diagram.

Figure 42. - Concluded.

high-pressure oxygen subsystem with a corresponding redesign of the subsystem components, incorporating an auxiliary water tank for storage of additional feedwater, increasing the size of the power supply with the mounting provisions redesigned to support the increased weight, and increasing the amount of LiOH by using revised cartridge-packing techniques.

The SV730101-3 OPS was the result of extensive qualification and manned test programs performed on the SV730101-2 OPS configuration. This testing revealed that oxygen flow, pressure regulation, and crewman thermal comfort could be maintained without the OPS heater. Thus, the heater, the temperature controller, the battery, and all other electrical equipment on the OPS were deleted.

A new item, the BSLSS, was added to the EMU for use if loss of cooling occurred in the PLSS. The BSLSS consists of a pair of water umbilical hoses with a standard connector on one end and a special divider connector at the other end. A tether strap, two snap hooks, and an insulation sheath complete the assembly. If one crewman's PLSS water cooling capacity is impaired or lost, he disconnects the normal PLSS water umbilical and connects the standard connector end of the BSLSS to his suit. The

other crewman, whose PLSS is still functioning normally, disconnects his PLSS water umbilical, attaches the divider connector to his PGA, and reconnects the PLSS water umbilical to the other side of the divider connector. The transport water flow from the functioning PLSS is now shared by the two crewmen. The tether hooks are attached to the PGA LM restraint brackets so that the tether relieves the water hoses of any strain.

Evolution of the PLSS and OPS

Evolution of the PLSS and emergency oxygen provisions was marked by several changes that resulted from a better appreciation of equipment capability, significant changes in the state of the art of available equipment, revised mission performance requirements, additional firesafety standards for materials in the presence of oxygen, and improved knowledge of man's requirements and physical limitations. Implementation of these changes resulted in the Apollo 11 crewmembers using the eighth configuration of the emergency oxygen supply system. The changes in requirements and configurations that have occurred are summarized in tables VI and VII and in figures 43 and 44, and the rationale behind the major design changes is presented in the following paragraphs.

Liquid-cooled PLSS. - Revisions in the specified metabolic heat rejection rate had the most influence on changing the physical makeup of the PLSS. The original requirement for metabolic heat rejection was an average rate of 273 watts (930 Btu/hr) and a peak rate of 469 watts (1600 Btu/hr). Traditionally, personnel in aircraft have been cooled by gas ventilation systems, which carry heat from the generating source to the rejection device, through a rise in temperature of the ventilating gas (sensible means) or through an increase in the absolute humidity of the ventilating gas caused by evaporation of available moisture (latent means). This approach was used on the Mercury, Gemini, Apollo CM, and Apollo LM vehicles and was considered appropriate for the original PLSS. A limitation of this approach is that the sensible capacity of the ventilating gas is quite small because of the limited flow caused by fan power considerations and the small differential between the minimum practical heat exchanger outlet temperature and the allowable maximum skin-surface temperature.

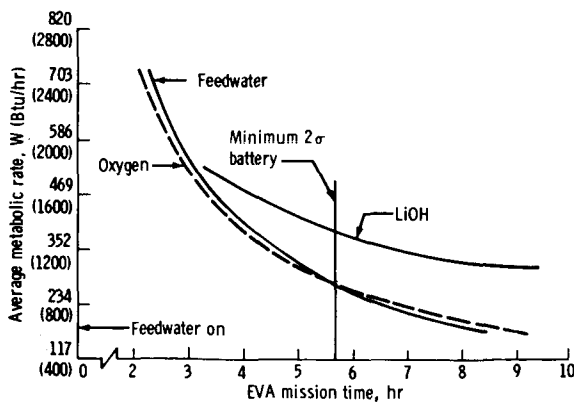

Figure 43. - Early Apollo PLSS expendables duration (Apollo 9 to 14 missions).

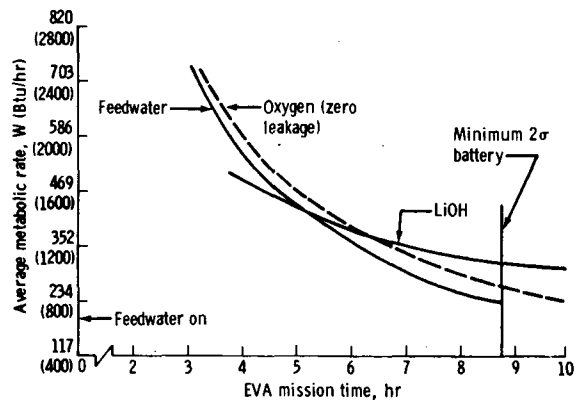

Figure 44. - Extended Apollo PLSS expendables duration (Apollo 15 to 17 missions).

TABLE VI. - PORTABLE LIFE-SUPPORT SYSTEM CONFIGURATIONS

Hardware item	Part number	Configuration or changes
Gas-cooled PLSS	SV585200	Not applicable
Liquid-cooled PLSS	SV594750	First prototype water-cooled system
	SV706100-1	Revised envelope for vehicle stowage Increased duration and heat rejection specification Added instrumentation Incorporated cryoformed oxygen tank
	SV706100-2	Altered complete PLSS electrical system
	SV706100-3	Added water quantity sensor and other instrumentation Relocated emergency oxygen system (EOS) from PGA to PLSS Incorporated Whitaker pump Incorporated space suit communications (SSC)
	SV706100-4	Enlarged water separator Deleted water quantity sensor Incorporated blade antenna
	SV706100-5	Added backflow check valve to vent loop Deleted transport water accumulator Added check valves to gas connectors Made extensive material changes Changed to high-reliability electronic components Added further instrumentation Changed from EOS to OPS Incorporated RCU
	SV706100-6	Replaced SSC with EVCS Added instrumentation and controls Incorporated visual warning flags
	SV706100-7	Increased expendable duration
EOS	SV585115	Two-stage regulator Spherical tank
	SV594200	One-stage regulator Toroidal tank
OPS	SV730101-1	One-stage regulator Two large spherical tanks Added heater, battery, and electronic controller
	SV730101-2	Was compatible with SV706100-6 PLSS
	SV730101-3	Deleted heater, battery, and electronic controller

Because studies indicated that the lunar surface EVA metabolic load might average 352 watts (1200 Btu/hr) over a 4-hour span or 469 watts (1600 Btu/hr) over a 3-hour span with peaks of 586 watts (2000 Btu/hr), it was apparent that the capacity of the gas ventilation system would be exceeded. Therefore, the system was revised to handle the above-average loads. In the present system, the ventilating gas still serves

TABLE VII. - SPECIFICATION REQUIREMENTS FOR THE PORTABLE LIFE-SUPPORT SYSTEM

Design requirements	Gas-cooled PLSS	Liquid-cooled PLSS	
		^a SV706100-5 and ^b SV706100-6	^c SV706100-7
Average metabolic load, W (Btu/hr)	272 (930)	469 (1600)	469 (1600)
Peak metabolic load, W (Btu/hr)	469 (1600)	586 (2000)	586 (2000)
Maximum heat leak in, W (Btu/hr)	73 (250)	73 (250)	88 (300)
Maximum heat leak out, W (Btu/hr)	73 (250)	73 (250)	103 (350)
Maximum CO ₂ partial pressure, N/m ² (mmHg)	1013 (7.6)	1999 (15)	1999 (15)
PGA pressure, kN/m ² (psia)	24 and 35 (3.5 and 5.0)	26.5 (3.85)	26.5 (3.85)
Ventilation flow, m ³ /min (ft ³ /min)	0.51 (18)	0.16 (5.5)	0.16 (5.5)
Minimum duration, hr, at 272 W (930 Btu/hr)	4	(d)	(e)
Oxygen charge pressure at 294 K (70° F), kN/m ²	6550 (950)	7030 (1020)	9720 (1410)
Battery capacity, J (W-hr)	1.04 × 10 ⁶ (290)	1.00 × 10 ⁶ (279)	1.29 × 10 ⁶ (360)
Emergency oxygen:			
Minimum duration, min	^f 5	^g 30	^g 30
Maximum flow, kg/hr (lb/hr)	^f 0.91 (2)	^g 3.6 (8)	^g 3.6 (8)
PGA pressure, kN/m ² (psia)	^f 23.8 (3.45)	^g 25.5 (3.7)	^g 25.5 (3.7)

^aConfiguration used on Apollo 9 and 10 missions.

^bConfiguration used on Apollo 11 and 14 missions.

^cConfiguration used on Apollo 15 to 17 missions.

^dRefer to figure 43.

^eRefer to figure 44.

^fEOS.

^gOPS.

to transport a limited amount of heat, but a water loop is introduced solely for transporting metabolic heat sensibly rather than latently. A special undergarment, the LCG, was devised to form, in effect, a plastic tubing heat exchanger. The LCG is worn against the crewman's body surface, and water is recirculated at 1.8 kg/min (4 lb/min) through a network of tubing distributed over the body surface roughly in proportion to the body mass, from the wrist and ankle of the limbs to the neck on the upper torso. Heat is transferred from the crewman's skin through the tubing wall into the water, which carries the heat to the sublimator in the PLSS. The large sensible capacity of water permits the 1.8 kg/min (4 lb/min) to carry the maximum design load of 586 watts (2000 Btu/hr) with a temperature rise of only 4.6 K (8.3° F). The temperature of the crewman's skin can be held sufficiently low to inhibit sweating.

Conceptual changes. - A number of other changes were made to the original concepts as certain items were found to be unnecessary or impractical. Typical of these changes were those to the emergency power supply and to the antenna for the space suit communications (SSC) unit.

As originally conceptualized, the emergency power supply was a battery to be used to power the communications system in the event of failure or premature depletion of the main power supply. Analysis of the reliability of the silver zinc alkaline battery once it had been activated showed the emergency power supply to be unnecessary. The added complexity of the system caused by the addition of the redundant power supply did not warrant the change.

The initial design of an antenna for voice communications and data telemetry called for a toroidal antenna that was to be embedded into the helmet. During the design of the suit/helmet interface, the electrical interconnection between the antenna and the communications unit was found to be extremely difficult to make because of alignment problems. The difficulty was compounded by the requirement for a 5-second helmet donning period. Accordingly, the antenna was relocated to the top of the PLSS. At the same time, the antenna was changed from a toroidal shape to a monopole blade. When the OPS was added to the system, the antenna was subsequently placed on top of the OPS.

Incorporation of the sublimator. - In the initial gas-cooled concept of the PLSS, cooling was achieved by the ventilation gas carrying heat from the point of generation to the heat rejection device, which was a plate-fin, wick-filled water boiler. All the water required for rejecting heat to space by boiling was carried in the wick reservoir. The temperature at which boiling occurred was controlled by a back-pressure valve placed in the steam duct leading overboard to space vacuum. This valve was actuated by the expansion and contraction of a small quantity of a special wax and metal particle mixture that exhibited a very high rate of volume change with temperature. The valve was adjusted so that the temperature at which boiling occurred was maintained in the 275- to 283-K (35° to 50° F) range. If the rate of heat rejection increased, the rate of steam production would increase and cause a rise in pressure and consequently elevate the boiling temperature. The temperature-sensitive valve would then respond by opening. The reverse would be true for a reduction in heat rejection rate.

With the change to higher metabolic loads and the water-cooled concept, it was decided to change from the water boiler concept to the sublimator to take advantage of its improved performance. Developmental work on this new type of space heat exchanger had shown improvements over the water boiler of approximately 30 percent in heat rejection per 0.45 kilogram (1 pound) of equipment and approximately 40 percent in heat rejection per unit of volume. As designed for the PLSS, the sublimator (fig. 45) contains flow paths for both the ventilating gas and the transport water. Adjacent to the plates that form the walls of these passages are sintered nickel plates having micrometer-size pores. One side of the porous plate is exposed to vacuum; the cavity between the other side of the porous plate and the transport fluid passage plate is filled with water under slight pressure. The slight pressurization is derived from the internal suit pressure. This "feedwater" is carried in a reservoir in sufficient quantity to satisfy all heat rejection requirements. As the feedwater exudes through the pores of the sintered plate, it freezes on the vacuum side and forms, in effect, a seal against

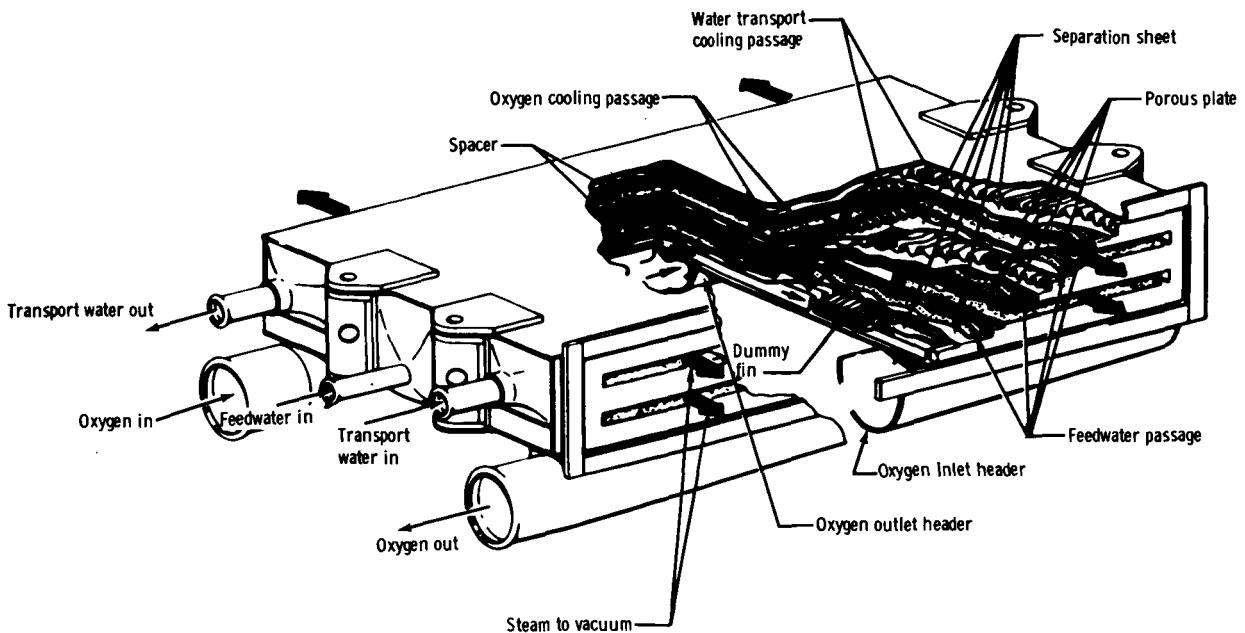

Figure 45. - Sectional view of the sublimator.

feedwater loss. Heat transferred from the gas path or from the transport water path is carried through fins and through the feedwater to the porous metal plate. The rate of sublimation of the ice formed on the porous plate is a direct function of the amount of heat carried to the sublimator by the transport fluids. Entirely self-regulating, this system requires no valving to control the amount of feedwater admitted to the sublimator section, nor does it require a temperature-sensitive or pressure-sensitive valve to maintain a controlled pressure in the boiling chamber for temperature control.

Oxygen supply bottle .- The original high-pressure oxygen tanks used on the first PLSS, built in 1963, were constructed of heat-treated AISI 4130 alloy steel with a protective coating of electroless nickel to prevent corrosion. Considerable difficulty was encountered in obtaining a satisfactory protective coating on the inside tank surface. Inspection techniques were quite difficult, and, because of the lack of assurance of a satisfactory continuous coating of electroless nickel, frequent inspection was necessary to ensure that no degradation of the inner surface occurred in the presence of small amounts of moisture and pure oxygen.

While these problems were being experienced, a development program was in progress on a manufacturing process that showed considerable promise of achieving excellent high-strength characteristics in a material having inherently high corrosion resistance in the presence of pure oxygen. Consequently, a subcontract was awarded for the development of a tank for the PLSS. Basically, the manufacturing process involves stretch forming a semifinished tank of a special grade of AISI 301 stainless steel to a finish die by pressurizing the tank with liquid nitrogen. The resultant "work hardening" of the material at a very low temperature gives excellent unaged physical properties; for example, the ultimate tensile strength for design purposes is

$165 \times 10^7 \text{ N/m}^2$ (240 ksi) compared to approximately $124 \times 10^7 \text{ N/m}^2$ (180 ksi) for the heat-treated AISI 4130 steel. The high ultimate tensile strength enabled the fabrication of a thinner walled vessel, which weighed much less than the original oxygen bottle. Thus, all PLSS oxygen bottles have been fabricated by this process.

Fan and motor assembly development. - The original fan and motor assembly consisted of a centrifugal fan with backward-curved blades rotating in a vaneless diffuser housing driven by an alternating-current motor using a static inverter. This approach was selected because of a requirement for brushless operation, and it was judged that an alternating-current motor using a static inverter for conversion of the dc power supplied by the battery represented the most feasible approach because no brushless dc motor of the size range required existed. During prototype testing, the control electronics proved successful; however, fabrication of the dynamic portion of the motor was unsuccessful. No successful fabrication technique could be found, and schedule delays were encountered. A brushless motor using a chopped dc voltage input was being developed at that time, and a decision was made to change to this approach. This second concept was successfully developed and is currently used on the PLSS. Initial development of the chopped dc motor was performed by a subcontractor. Problems of poor quality control and inadequate delivery schedules on the part of this vendor were encountered. Accordingly, the program was assumed by the prime contractor, and the problems were resolved. The initial motors fabricated to this design had an erratic starting characteristic; on starting, the motor might rotate either clockwise or counterclockwise. This problem was resolved by complete redesign of the starter circuit.

During initial system level testing, a significant gas temperature rise occurred across the fan as a result of the gas absorbing the heat generated by the motor electronics. Because the temperature rise was excessive for the specification gas loop operation, the fan motor housing was redesigned to incorporate a flow path for water from the water transport loop. This technique proved successful; a negligible temperature rise occurred in the ventilation circuit, and the heat was removed by the water.

The LiOH cartridges. - A bed of LiOH granules was used for removing CO_2 from the oxygen stream. This technique was chosen because it offered advantages in absorption capacity, low heat of reaction, speed of reaction, and weight over other CO_2 removal methods. In the initial units, the granular LiOH could abrade when a unit was subjected to vibration, and the dust generated was very caustic and irritating to the eyes, the nose, and the throat. Consequently, the design was changed by compressing the granules tighter within the container so that relative motion was inhibited. In addition, the packing procedure was changed so that the granules were alternately loaded and vibrated lightly to settle them until the unit was properly filled. A foam material was used to compress the granules.

Several types of LiOH were tested during the development program. Because of the quantity of CO_2 with which it could react, an LiOH monohydrate was chosen because it contained the necessary water of hydration to permit CO_2 removal from the ventilation circuit immediately on startup. This particular type of LiOH, however, was found to be temperature and vacuum sensitive. Exposure to vacuum withdraws the water of hydration and thereby slows down the reaction capability. Exposure to temperature changes causes the water of hydration to cycle in and out of the LiOH and results in

a glazing of the LiOH surface that reduces the capability of the LiOH to react with CO_2 . To ensure that the LiOH was not unknowingly exposed to vacuum or to temperature extremes, strictly controlled storage was required and temperature-sensitive decals were placed on the LiOH cartridge and on the cartridge container assembly (fig. 46) to indicate any high-temperature exposure.

Water pump. - The initial concepts for pumping the coolant flow were based on centrifugal pumping principles. The basic difficulty was that the efficiency of a centrifugal machine for the small flow and low head requirement was unacceptably low. When it was determined that a small diaphragm pump was being developed, a contract was placed to develop a model that would meet PLSS requirements. This development was aimed at minimizing the amount of power consumed so that the battery, which is one of the heavier and bulkier components, could be reduced in both size and weight. The pump includes two small diaphragms at the end of a walking beam supported by a torsion rod. Inlet and outlet valves are provided for each diaphragm chamber. Part of the walking beam structure is a magnetic armature that can be moved in either direction by an electromagnetic field to effect displacement of the diaphragms by the walking beam. The electromagnetic field polarity can be reversed by an electronic control at a frequency chosen to be nearly coincident with the natural frequency of the spring mass system supported by the torsion bars. By properly tuning the driving frequency to that of the resonance of the system, a significant reduction in electrical input power is achieved for a given pumping load. This pump requires approximately 10 watts of input power to pump 1.8 kg/min (4 lb/min) with a head pressure of 39 kN/m^2 (5.65 psi). Equivalent performance by a centrifugal machine required 30 watts of input power.

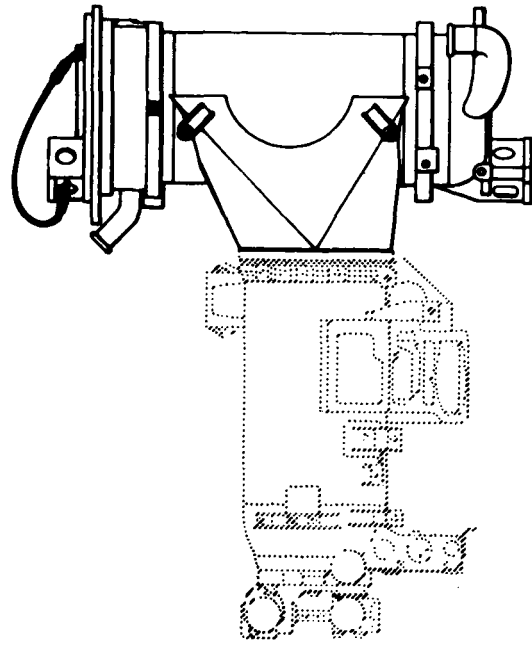

(a) Canister and reservoir assembly.

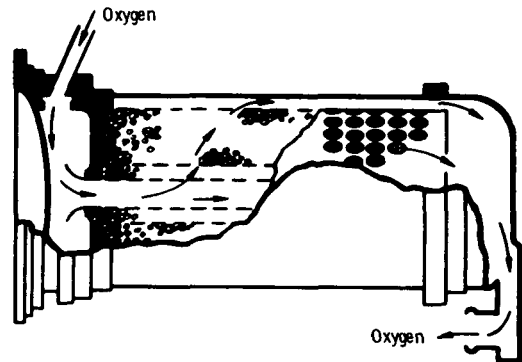

(b) Canister flow diagram.

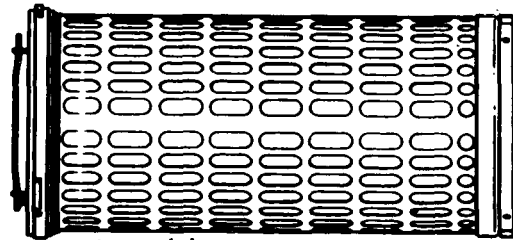

(c) Cartridge.

Figure 46. - The LiOH cartridge.

During an unmanned system performance test, the fan generated transient pulses on the power line and caused open-circuit failures in the pump. To prevent these pulses from entering the pump, a high-speed switching diode was incorporated into the pump electronics, and the fan power lead was connected to the battery side of the electromagnetic interference (EMI) filter.

Water separator. - Water separation from the ventilation loop is performed by an elbow separator that centrifuges entrained moisture from the recirculating gas and transfers the moisture through a wick to the storage portion of the feedwater reservoir. The design of the water separator had been based on a continuous entrained moisture level. The initial manned tests determined that the moisture tended to puddle in the sublimator as it condensed. As the test subject moved, slugs of water would be discharged from the sublimator. These slugs exceeded the storage capability of the water separator, and water was discharged. To correct this problem, the total wicking volume was increased.

Feedwater system. - The original expendable water system had undergone several conceptual changes. The water supply system on the LM, which is used to recharge the PLSS on the lunar surface, is nitrogen saturated. A positive displacement feed system was needed for the LM because the feed system must operate in a zero-g environment. The method selected was a nitrogen-pressurized bladder. Nitrogen saturation of the water occurs because the bladder material separating the water from the nitrogen is permeable to nitrogen. When this water was used to recharge the PLSS on the lunar surface, a bubble of nitrogen would form at the top of the bladder in the feedwater reservoir, and the bladder would not be fully recharged. To prevent this occurrence, a standpipe was added to the reservoir, and a sight glass was added between the reservoir and the vent connector. When water is charged into the PLSS, flow is continued until water is observed in the vent-line sight glass.

The original PLSS concept included an expendable water quantity sensor to provide telemetered data on the remaining supply of water. This sensor was substantially beyond the state of the art, and resolution of the resultant problems had so slowed development of this item that further effort was terminated and the sensor was omitted from the PLSS.

The feedwater pressure transducer was added when the expendable water quantity sensor was deleted, and the vacated telemetry channel was used for feedwater pressure transducer data. The transducer provides data on water depletion and on sublimator performance degradation resulting from breakthrough or loss of feedwater pressure. A problem was experienced with water freezing in the feedwater pressure transducer during deactivation. Because of the orientation and plumbing of the transducer, exposure to vacuum during deactivation resulted in freezing of some water within the transducer and subsequent damage to the sensing element. This problem was resolved by putting a flow-limiting orifice into the transducer inlet, thereby reducing the boil-off rate and preventing freezing.

Emergency system. - Three emergency oxygen systems were developed or qualified during the program. The first two configurations were both called the emergency oxygen system (EOS) and performed identical functions. The EOS supplied oxygen to the crewman in the event of a failed-open PGA relief valve, excessive suit leakage,

or any failure causing low PGA pressure or insufficient ventilation flow. The EOS was an open system that provided oxygen to the PGA ventilating system. Instead of recirculating as it did in the PLSS, the oxygen exhausted to the ambient environment through a purge valve mounted on the PGA torso subassembly. The purge valve was actuated by the crewman after actuation of the EOS. A sufficient quantity of oxygen was contained in the EOS to maintain PGA pressure at 25.5 kN/m^2 (3.7 psia) for 5 minutes with a failed-open PGA relief valve.

Major components of the EOS were a supply-oxygen reservoir, a lanyard-type actuating mechanism, a two-stage regulator, a fill valve, a reservoir pressure-sensing gage, a PGA purge valve, and a quick-disconnect coupling. The supply-oxygen reservoir was charged with oxygen to $51\,710 \text{ kN/m}^2$ (7500 psia). The quick-disconnect coupling mated with the multiple gas connector on the PGA. Both EOS units provided for a 5-minute emergency flow at 0.91 kg/hr (2 lb/hr), but a later configuration, which used a single-stage pressure regulator nested in a toroidal tank rather than a two-stage regulator in a spherical tank, reduced the volume to one-third and the weight to two-thirds of the original configuration.

In mid-1967, mission requirements were reviewed and revised to establish the need for additional emergency oxygen to permit EV excursions to greater distances from the LM. The OPS that was designed for the new requirement performs the same function as the EOS; however, the OPS provides a minimum of 30 minutes of flow at 3.63 kg/hr (8 lb/hr) (for increased metabolic heat rejection) and an extension of the safe EVA range. The fill valve, regulator, and pressure gage designs were direct derivations from the EOS. The EOS was sealed by a rupture disk that was punctured by an actuation system to allow the release of the gas when needed. This concept was omitted from the OPS in favor of a multicycle shutoff valve as field experience with the EOS revealed that training and preflight acceptance testing were excessively limited by the one-cycle feature of the EOS.

When design of the OPS was initiated, analytical studies of the adiabatic cooling of the gas from the oxygen bottle indicated that the gas could freeze in the regulator. This potential problem, coupled with the requirement for an outlet gas temperature between 272 and 300 K (30° and 80° F), led to the incorporation of an electric heater with an automatic temperature controller. Initial feasibility tests confirmed that freezing was possible. Only after extensive qualification testing was it demonstrated that the OPS could be operated successfully without the heater, and the heater and associated components were subsequently deleted.

With the addition of the OPS to the life-support system, a backflow check valve had to be added to the PLSS. The changes made to the PLSS and the suit at that time would have permitted gas from the OPS to flow in reverse through the PLSS and then out the suit purge valve and thus to bypass the suit flow path necessary for life-support and cooling purposes. The backflow check valve is a low-pressure-drop reed valve that effectively prevents reverse flow of oxygen.

Added instrumentation. - Throughout the course of the program, instrumentation has been added to the PLSS to provide additional alarm systems for warning the crewman of off-nominal performance and to provide additional telemetry data for Earth monitoring of the performance of the PLSS and for monitoring the crewman. Typical

of this instrumentation are the high oxygen flow sensor (detecting excessive oxygen flow from the oxygen bottle), the primary oxygen subsystem pressure transducer (measuring pressure in the oxygen bottle and thus the quantity of oxygen remaining), the LCG inlet temperature transducer (measuring the temperature of the fluid leaving the sublimator), and the CO₂ sensor (measuring the partial pressure of CO₂ in the ventilation loop).

Nonmetallic materials. - As a result of the Apollo spacecraft 204 accident, new firesafety criteria were established governing the use of all nonmetallic materials exposed to oxygen or otherwise used in the life-support system. These new criteria necessitated the partial redesign of the thermal cover and of some components in the oxygen and electrical subsystems to eliminate certain undesirable materials or to prevent their exposure to fire-inducing or fire-supporting environments. All materials to be used in the life-support system were proved to be eligible either by existing test data or by specific combustion tests on samples of the specific materials. Changes were made to incorporate eligible materials.

The RCU. - The gas-cooled PLSS had the controls mounted on the front of the PGA. The first water-cooled PLSS had the electrical controls (fan and pump switches, volume control, and mode selector switch) located in the lower left corner on the front of the PLSS; the mechanical controls were (and are) on the right-hand side. During the system redesign after the Apollo spacecraft 204 accident, these electrical controls were removed from the PLSS and installed in a box (called the RCU) to be mounted on the chest of the suit for operating convenience. The oxygen quantity indicator also was installed in the RCU. This allowed the crewman greater access to the controls and greater ability to view continuously the oxygen pressure, the mode selector switch position, and the fan switch position. The RCU was stowed separately from the PLSS and connected to it electrically after being mounted on the PGA chest area by two upper hooks that attached to the PLSS straps and a lower hook that attached to the D-ring of the suit. Aluminum tape was added to exposed nonmetallic surfaces for fire protection, and the electrical cable was covered with a Beta-cloth sheath. The OPS actuator was mounted on the side of the RCU. Switch guards were added to prevent accidental switching of the fan or pump.

For the Apollo 11 mission, the RCU was further refined to incorporate warning indicators (flags), a new mode selector switch, and a new dual volume control (one for receiving through the LM transmitter, the other for receiving the other EV crewman) that were compatible with the EVCS. Also, the upper mounting hooks were modified to provide positive locking. The OPS actuator release handle was repositioned to preclude inadvertent release, and a camera-mounting bracket was added at crew request to allow "hands free" camera aiming and generally to simplify photography. This bracket was partly detachable to allow unaffected stowage of the RCU and to aid in ingress and egress. Another addition to the Apollo 11 PLSS was the push-to-talk switch that allows the crewman to bypass the voice-operated relay of the EVCS. This switch is a three-position, double-pole, double-throw toggle switch with a center "off" position. One position is maintained momentarily (spring loaded to return to the center "off" position when released); the other position is an "on" position (that is, not momentarily). Five warning indicators were incorporated in the RCU to provide the crewman with a visual warning of a failure in the EMU. In the event of a failure, the face of the associated indicator will expose a black surface with white lettering. In the normal mode, a clear white surface is visible. The lettering on the indicator surface

assigns a specific course of action that must be taken to solve the problem (P for purge, A for abort, O for OPS makeup). The indicator will remain in the energized position until the failure has been resolved; only then will it return to the deenergized position (white face). Beta lights were incorporated into the face of the RCU to provide illumination of the warning indicators and the oxygen quantity indicator. Beta lights are sealed glass capsules, internally coated with a phosphor and filled with a radioactive gas (tritium). The radioactive decay particles are absorbed by the phosphor to produce a blue light in the visible spectrum.

Transport water loop. - The initial design of the pump (centrifugal) required a relatively high pressure (approximately 131 kN/m^2 (19 psia)) to prevent cavitation. To accomplish this pressurization, it was necessary to provide an accumulator in the transport loop. In addition, the accumulator, a spring-loaded-piston device that held approximately 0.45 kilogram (1 pound) of water, provided for any systems leakages.

Extensive testing during the pump development program demonstrated that the pump could be operated at low pressures. The transport loop was then redesigned without the accumulator. With the loop operating essentially at suit pressure, it was possible to connect the feedwater loop to the transport water loop with a check valve. This change provided continuous transport loop recharge capability and eliminated the need for a fill connector for the transport loop. The net effects of this change were a significant reduction in system weight, a reduction in operational complexity, and an increase in system reliability.

Main power supply. - The design requirements for the LM specified that the on-board electrical power was to be provided by fuel cells; therefore, the battery for the PLSS was designed to be rechargeable from the LM for the second and any subsequent EVA's. However, the LM fuel cell was eliminated because of performance, reliability, cost, and availability considerations, and LM onboard electrical power was provided by batteries. Because it was no longer possible to recharge the PLSS battery from the LM supply, the battery was changed from a rechargeable to a nonrechargeable configuration. Batteries were carried on the LM for each EVA. This change permitted the incorporation of a safety feature on the battery. The rechargeable configuration of the battery had a male electrical connector, which had the potential for fire hazard or for internal damage to the battery because of inadvertent shorting of the pins by tools or other means. As a result of the change to a nonrechargeable configuration, a female electrical connector that removed the potential hazard could be incorporated.

Ventilation flow sensor. - Several methods to sense flow in the ventilation circuit were evaluated. The initial approaches concentrated on sensing fan performance because fan performance was the primary key to gas flow. The two simplest techniques were the measurement of fan rotational speed and the measurement of a pressure rise across the fan. Both these techniques were dropped because they would not effectively reflect a blockage or disconnection in the ventilation system. The technique that was chosen was the insertion of a low-pressure-drop venturi tube into the line downstream from the fan outlet and the measurement of the resultant pressure drop. The sensing of the pressure drop was accomplished by the measurement of changes in capacitance between two parallel plates that moved in response to pressure changes. The initial

units were determined to be sensitive to ambient temperature changes and to the entrapment of moisture between the parallel plates, which changed the capacitance characteristics. The temperature sensitivity was resolved by a minor modification to the electrical circuitry. The sensitivity to moisture could not be resolved without a complete redesign of the measurement concept. Because the basic concept of the unit was fully adequate, the problem was resolved by instituting a requirement for a thermal-vacuum drying of the sensor after any usage in a humid environment.

High-reliability electronics . - In accordance with Apollo Program policies, all resistors, diodes, capacitors, transistors, and similar electrical and electronic hardware were designed for high reliability. However, early in the program, it became apparent that high-reliability test and initial nonflight units could not be obtained on a satisfactory cost or schedule basis because of the extensive test programs and component burn-in requirements of the high-reliability specification. Some simple, readily available electrical components had delivery schedules of as long as 9 months after ordering when high-reliability requirements were imposed. Therefore, the decision was made to use low-reliability components for the initial test programs and to phase high-reliability components into the system as they became available. This technique resulted in significant improvements in the schedule for completion of the initial program testing.

Communications system . - The initial communications system, the SSC system, was a hermetically sealed case containing electronic components for communications and for telemetry of physiological and suit environmental data. The SSC capabilities included a primary duplex voice communications system between the two crewmen (using the LM onboard transceiver station as a relay station), a secondary duplex voice communications system between the two crewmen, provision for telemetry transmission of seven channels of physiological and suit environmental data, an audio tone system to warn the crewmember of dangerous suit environmental conditions, and voltage regulation for the external transducers. .

The original liquid-cooled PLSS was designed on the basis of one EV crewman at a time, and the SSC system design reflected this requirement. Early in 1967, the requirement for two simultaneous EV crewmen was established. For a dual EVA, the SSC system provided for voice communications of both crewmen and for telemetry transmission of either crewman but not for telemetry transmissions of both crewmen simultaneously. In addition, EVA would have been limited to line of sight between the LM and the crewmen to maintain communications with Earth. Consequently, a new communications system, the EVCS (figs. 47 to 49), was designed and incorporated into the PLSS. The EVCS provides the following additional capabilities: continuous telemetry data relayed to Earth simultaneously from both crewmen; 19 additional telemetry channels; line-of-sight limitation for EV exploration eliminated for one crewman (with the other crewman's communications system serving as a relay station to the LM); and greater output power to increase the operating range from the LM.

Gas separator . - The LCG waterflow passages are constructed of flexible plastic tubing. The LCG is charged and then stored for some time before use. Because the flexible plastic tubing is slightly permeable to both air and water, some of the water in the LCG is displaced with air during this storage period. When the LCG is connected to the PLSS at the reduced pressure level 20.6 kN/m^2 (3 psi), the quantity of air present

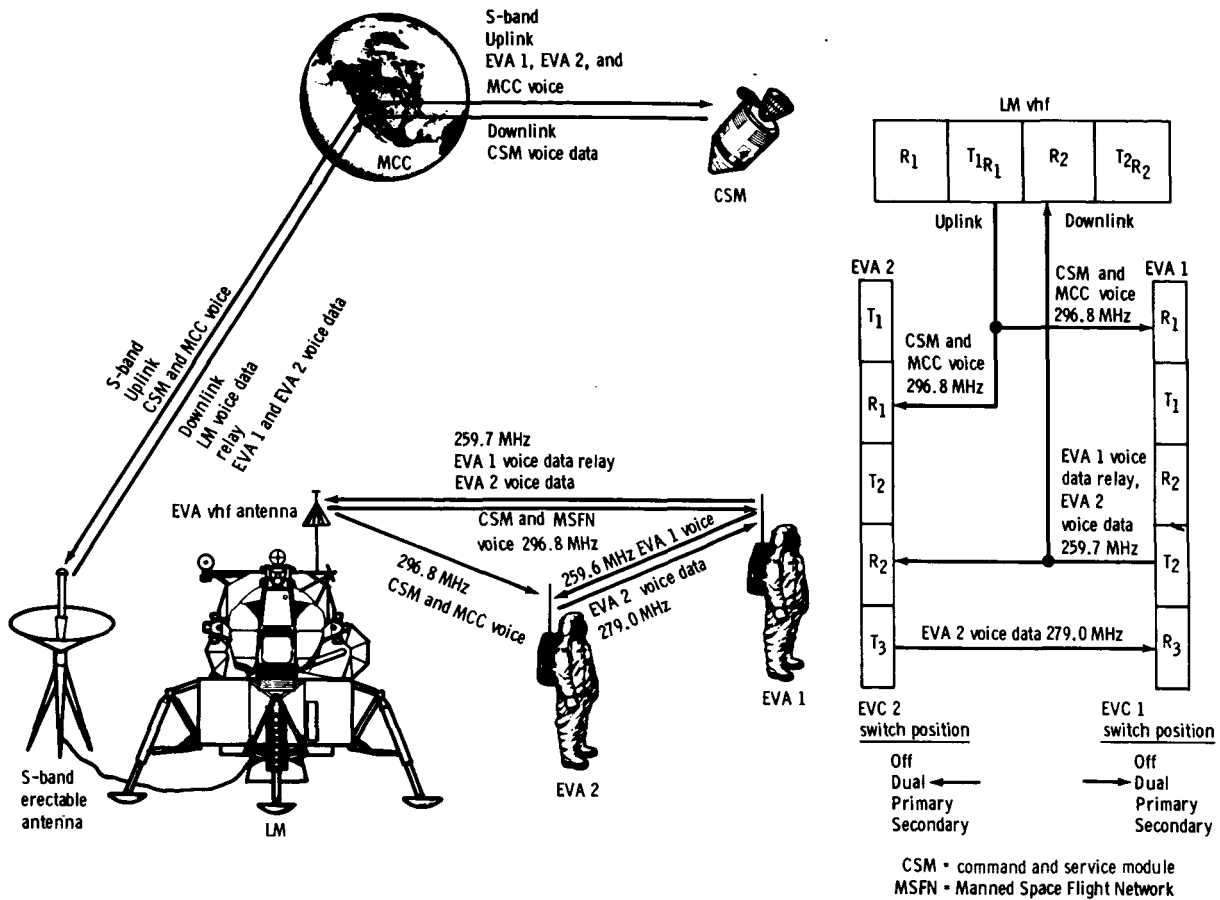

Figure 47.- Extravehicular communications system pictorial diagram: dual-dual.

in the LCG is sufficient to cause performance degradation of the pump and, in the worst cases, cavitation. Gas may also be introduced into the system during feedwater recharging from the LM water system. To prevent damage to the pump, a gas separator was added to the water transport loop, and a procedural change was initiated to seal the charged LCG in an evacuated plastic bag before stowage.

Hose delamination . - The hoses used in the oxygen and water umbilicals are composed of laminated silicone rubber with an integral wire stiffener to prevent kinking. These hoses are then encased in a multilayer sheath to minimize heat leak.

On some of the early PLSS units, excessive pressure drop was experienced in the oxygen ventilation circuit. Investigation showed the problem to be a partial blockage of the hoses caused by delamination of the inner wall of the hose when exposed to a negative pressure differential. The delamination was determined to be the result of inadequate manufacturing process control on the part of the hose manufacturer. The corrective action included the imposition of stricter cleanliness and quality control requirements on the supplier and the addition of a screening test (flexing of the hose followed by X-ray inspection under negative pressure) to the hose production acceptance test.

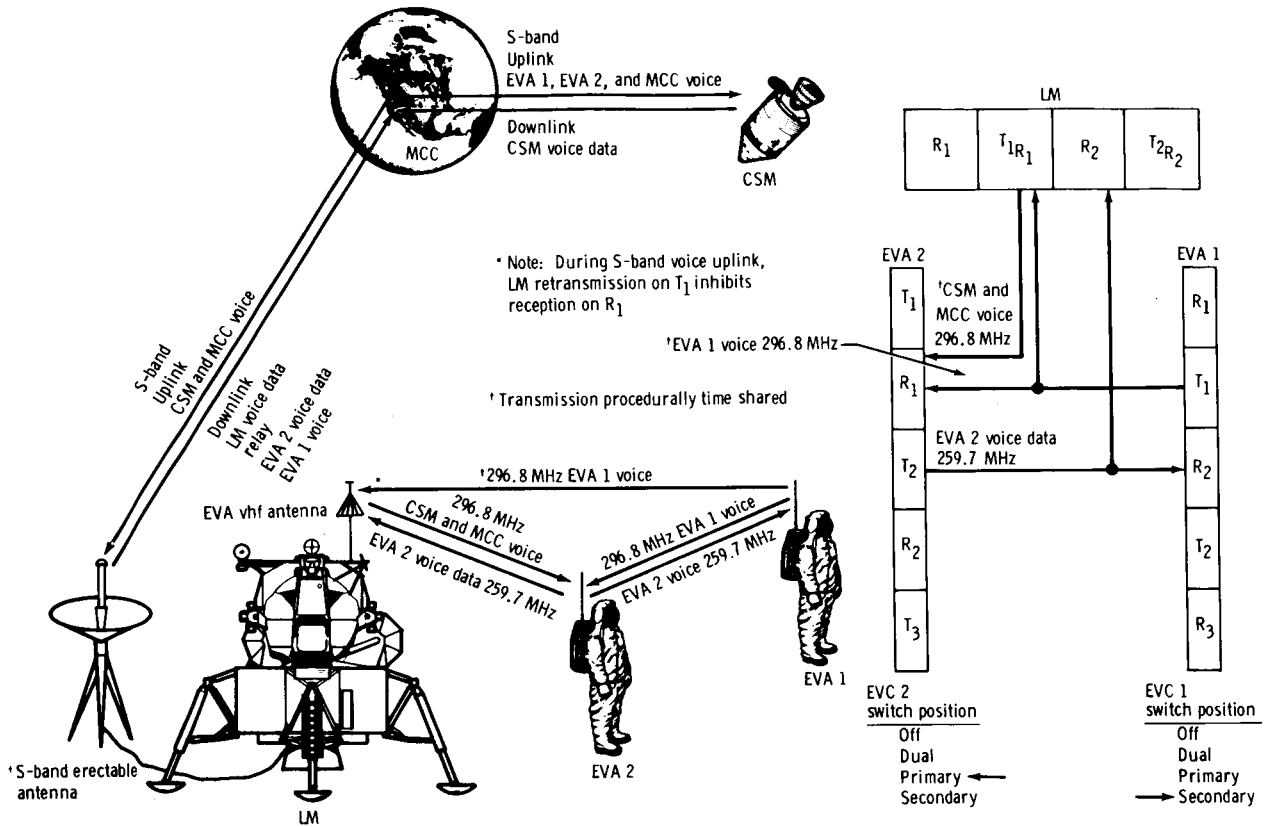

Figure 48. - Extravehicular communications system pictorial diagram: dual-secondary.

Terminal boxes. - Electrical discontinuities and cracks in the solder joints between the current terminals and the printed circuitry were detected in some of the PLSS terminal boxes. Investigation showed that the solder being used was brittle and susceptible to cracking. Corrective action included reworking all printed circuit/terminal pin solder junctions by applying convex solder caps using SN 60 or SN 63 solder. This solder had a lower melting point, was less brittle, and thus was less susceptible to cracking. Additional heat sinking of areas to be soldered and more complete checkout procedures were also added, and these proved to be successful.

The OPS seals. - The OPS design was initiated after the Apollo spacecraft 204 fire and, consequently, reflected the firesafety criteria from the conceptual stage onward. Firesafety criteria specified that the necessary O-ring seals were to be made from Viton A with Vespel backup rings. Investigation of repeated O-ring failures showed that gas saturation of the Viton A was causing swelling, blistering, splitting, and extruding of the seals used on the high-pressure side of the regulator. Therefore, the Viton A material was replaced by silicone rubber, and the Vespel material was replaced by Kel-F material. Seal performance has been satisfactory since then.

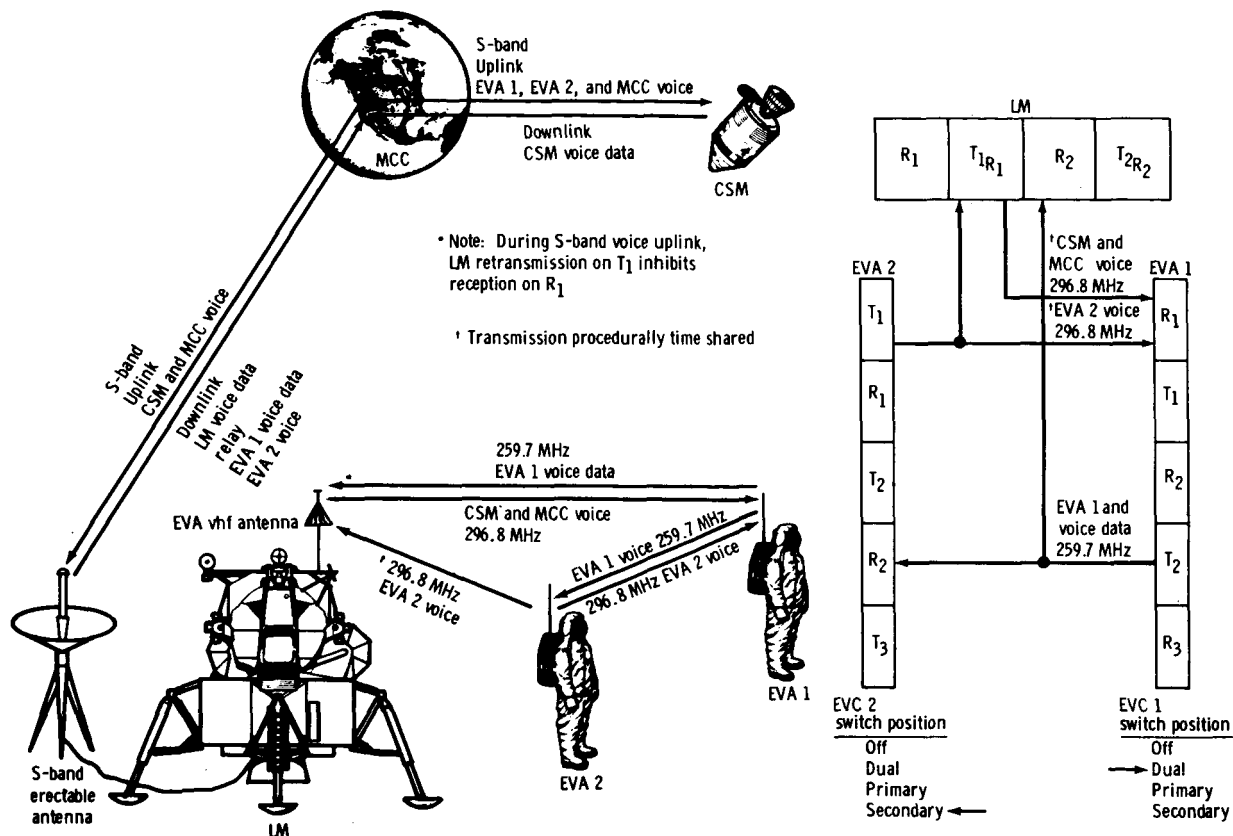

Figure 49. - Extravehicular communications system pictorial diagram: secondary-primary.

QUALIFICATION TESTING

Qualification of Apollo EMU hardware was based on formal tests and previous mission usage of similar items. Because the configuration of EMU items changed as mission applications evolved, testing accomplished by using an earlier configuration than that scheduled for the mission served as a baseline reference for additional incremental or delta qualification. Where changes in configuration were minor, previous test experience justified qualification by similarity. If changes were significant enough to invalidate qualification by similarity, additional testing was accomplished to verify that the current configuration was qualified for the intended mission application.

The requirements for the various qualification test exposures were derived from a detailed analysis of mission operations and of spacecraft- and mission-induced environments, from mission thermal analysis, and from detailed evaluations of EMU/spacecraft/crew interface requirements. The formal qualification tests subsequently performed can be grouped into one of three categories: life-cycle testing, design-limit testing, or nominal-mission testing.

Life-cycle testing was based on a factor of two times the maximum number of operations anticipated for flight items throughout the crew training, ground test, and operational phases of the anticipated mission. Most cycling was accomplished in the normal operating mode of the equipment being tested. All cycles performed were accomplished at the maximum amplitude of movement expected during mission and support usage. This activity included operation of all equipment, closures, connectors, and controls. The method used for conducting cycling tests was to exercise each flexible and manual aspect of the equipment repeatedly to the limits established for each mission. Periodic checks, operating torque, force to connect and disconnect, and structural integrity were conducted throughout the testing program.

Design-limit testing consisted of exposure to each mission-profile environment (singly applied), followed by a performance-record test to check minimum functional performance. In general, operation of the test item was not required during exposure. The environmental exposure tests were basically the same for the PLSS, the OPS, and the PGA, although the values of specific parameters (length of test, temperature, pressure, vibration spectra, etc.) varied depending on the component or subsystem being tested. Exposures to the following environments were conducted.

1. High-temperature and low-temperature thermal soaking to simulate spacecraft temperature excursions and stowage and shipment environments
2. Salt fog exposure to demonstrate the capability to endure long-term exposure to the corrosive effects of perspiration and salt air
3. Acceleration tests to simulate the g-level extremes encountered during launch, ascent, and descent
4. Shock tests to simulate accidental IV and EV impacts, lunar landing, and emergency Earth-landing shocks
5. Static load tests to simulate abnormal static loading (such as a crewman standing on the PLSS) that might be encountered during the mission

Where applicable, electrical insulation resistance, electrical continuity, examination of product, and minimum functional performance checks were conducted after exposure to the environments described previously to verify equipment durability and operability. Nominal-mission testing involved actual performance verification of the major subsystems of the EMU under simulated mission-profile environmental conditions. A description of the nominal-mission tests that were performed on the PGA, the PLSS, and the EMU during formal qualification testing is presented in the following paragraphs.

The PGA

The space-suit garments and associated hardware were subjected to design-limit environmental exposure for qualification for manned flight. The tests conducted are described as follows.

Oxygen and humidity exposure. - All items were placed in a thermovacuum chamber and subjected to the following environmental conditions.

1. Temperature: $330 \begin{smallmatrix} +5.6 \\ -0 \end{smallmatrix}$ K $\left(135 \begin{smallmatrix} +10 \\ -0 \end{smallmatrix}$ F) for 115 hours
2. Pressure: $137 \begin{smallmatrix} +3 \\ -0 \end{smallmatrix}$ kN/m² $\left(19.9 \begin{smallmatrix} +0.5 \\ -0 \end{smallmatrix}$ psia) for 24 hours
 $36 \begin{smallmatrix} +3 \\ -0 \end{smallmatrix}$ kN/m² $\left(5.2 \begin{smallmatrix} +0.5 \\ -0 \end{smallmatrix}$ psia) for 91 hours
3. Gas (oxygen): 95 ± 5 percent by weight
4. Relative humidity: 95 ± 5 percent

At test completion, the items were examined for signs of degradation before the next test series was begun.

Low-temperature environmental exposure. - All items were placed in a low-temperature environmental chamber and exposed to a chamber temperature of 230 K (-45° F) for 8 hours. When the exposure was terminated, the test items were removed and examined for degradation.

Salt fog environmental exposure. - The salt fog environmental exposure test series consisted of exposing the equipment to the corrosive effects of salt fog (simulating the effects of perspiration and sea air) for 48 hours at a temperature of 308 K (95° F) by using a reservoir solution of 1 percent sodium chloride in distilled water. The items were examined for degradation when the exposure was terminated.

Intravehicular impact environmental exposure. - The vibration environmental exposure test series exposed the equipment to design-limit vibration spectra as defined for the Apollo CM and LM during powered flight. The equipment was donned on a 15 percentile anthropomorphic dummy and placed in a simulated CM crew couch. The equipment was subjected to the design-limit vibration spectrum in the axial directions at various couch positions. Vibrations input to the couch were measured by three triaxially mounted accelerometers and recorded on magnetic tape. Vibration levels included those possible in mission-abort conditions. The structural and leakage integrity of all items was checked before and after each test.

Acceleration environmental exposure. - In the acceleration environmental exposure test series, the equipment was subjected to the design-limit acceleration environment applicable to the CM and the LM during powered flight. The equipment was donned on a 15 percentile anthropomorphic dummy constrained in a simulated spacecraft crew couch in the centrifuge facility. Acceleration levels reached a peak of 20g ± 0.3g. The test was performed unidirectionally, and the acceleration input was measured by three triaxially mounted accelerometers and recorded on magnetic tape. The structural and leakage integrity of all items was checked before and after each test.

Earth-landing impact environmental exposure. - During the Earth-landing impact environmental exposure test series, the equipment was subjected to design-limit Earth-landing impact shock as defined for the Apollo CM. The equipment was placed on a 15 percentile anthropomorphic dummy and subjected to impacts producing acceleration as high as 35g. Acceleration was measured as previously described. The structural and leakage integrity of all equipment was checked before and after each test.

Design-limit cycling of the space suit. - The design-limit cycling of the space-suit test series was conducted by suited test subjects cycling the suit at levels higher than would be incurred by the crewmen during training and flight usage. These cycling tests included donning and doffing all equipment; actuating all connections, zippers, et cetera; and performing a series of specific movements. The equipment was monitored continuously throughout the test series. Structural and leakage capability, degradation, et cetera, were recorded as a function of use cycles.

The PLSS

The PLSS was subjected to a total of 20 thermal-vacuum lunar mission profiles, each lasting 3 or 4 hours. Test conditions simulated lunar day, lunar night, and LM cabin temperatures and pressures as well as crewman heat loads and contaminant-level inputs. The total PLSS functional performance was evaluated for the three possible startup conditions: after a cold soak (116-K (-250° F) chamber wall temperature for 2 hours), after a hot soak (366-K (200° F) chamber wall temperature for 2 hours), and at ambient conditions.

The EMI testing was conducted on the combined PLSS/OPS to evaluate susceptibility to and generation of EMI. The program included investigation of radiated interference (broadband and narrow band), antenna-conducted interference, radiofrequency radiated susceptibility, communications receiver front-end rejection, and receiver intermodulation. During the tests, the PLSS transport-water and ventilating loops were operative; the fan, pump, SSC mode selector switch, and OPS were cycled off and on in various combinations to permit investigation of all possible modes of PLSS/OPS operation. Deactivation and charging tests verified the capability of the PLSS liquid loop (both feedwater and transport water) and the primary oxygen subsystem to withstand charging/discharging and deactivation that might be encountered during preflight testing and checkout and during the mission.

Phase I qualification testing of the model 5 PLSS, conducted during July and August 1968, was performed in three parts: EMI tests were conducted on the model 5 PLSS and the OPS combined; salt fog and humidity tests were conducted on the PLSS branched-wire harness and RCU harness; and nominal-mission and design-limit testing was performed on the model 5 PLSS. No serious anomalies were noted during the test.

Phase II qualification testing of the model 5 PLSS was conducted from October 25, 1968, to January 10, 1969. A series of performance and structural tests was performed. The performance tests were unmanned lunar-mission-simulation thermal runs and subsequent performance records, including SSC system evaluation. The structural tests consisted of nominal-mission PLSS and RCU vibration, thermal soaks, and primary-oxygen-bottle burst tests. During testing, the Lexan feedwater vent indicator cracked in the area of the threaded insert. The indicator was subsequently redesigned

and successfully qualified. No other serious discrepancies arose during testing, and the model 5 PLSS successfully met all Phase II qualification test requirements.

Differential (delta) qualification testing of the model 6 PLSS was conducted from January 30 to March 28, 1969. The testing was performed in three phases: EMI tests were conducted on the model 6 PLSS and OPS; environmental testing was performed on the RCU; and the model 6 PLSS was subjected to endurance-qualification and design-limit testing.

The qualification requirements for the model 6 PLSS were satisfied by the results of the model 5 Phase I (Earth-orbital mission) and Phase II (lunar mission) qualification test program (because of similarity of configuration) and by the model 6 delta qualification test program. The configuration changes made between the model 5 PLSS and the model 6 PLSS that necessitated the delta qualification testing were as follows.

1. The EVCS replaced the SSC.
2. The wiring harness had been modified to include additional instrumentation cables.
3. The terminal boxes had been redesigned to contain new or modified components.
4. The RCU had been redesigned to contain the following new or modified components: an EVCS mode-selector switch, a dual volume control, a push-to-talk switch, five warning indicators, and a panel light.
5. The alarm control module had been modified.
6. The sublimator oxygen temperature transducer was used.
7. The PGA differential-pressure switch and transducer had been modified.

No serious discrepancies were encountered during delta qualification testing; when the test program was completed, the model 6 PLSS was qualified for the lunar mission.

The formal qualification test program for the OPS was conducted from July to November 1968. Testing was accomplished in two series, with a separate OPS used for each. The first series was nominal-mission testing and the second was design-limit testing. These two test series were described in some detail earlier in this section.

Anomalies that occurred during testing included failure of the OPS actuator to activate the OPS and heater circuit and structural failure of the shaft and handle of the hardcover locking pin. The actuator cable was readjusted under load conditions and performed normally. The locking pin was redesigned to allow load distribution directly in line with the shaft. A delta qualification test was performed to verify adequacy of the hardware changes.

The delta qualification testing consisted of two nominal-mission tests (one hot start and one cold start), OPS actuator cycling, vibration and shock tests, a high-humidity exposure, and subsequent performance runs. On completion of the delta qualification tests, the OPS was qualified for lunar missions.

The EMU

The EMU qualification test program was conducted at various locations based on facility availability and program schedule requirements. Garment items were cycle tested at the vendor's facility; some environmental tests were conducted at the NASA White Sands Test Facility in New Mexico; and dynamic tests (vibration, shock, and acceleration) were accomplished at the NASA Lyndon B. Johnson Space Center (JSC) (formerly the Manned Spacecraft Center (MSC)). (End-item qualification tests of the PLSS and the OPS were conducted at the vendor's facility.) The EMU system EMI tests were conducted at MSC. The EMU system Earth-orbital tests were performed in the vendor's thermal-vacuum facility. The lunar surface functional demonstration was conducted in the Space Environment Simulation Laboratory at MSC.

Earth-orbital qualification tests. - The manned EMU Earth-orbital qualification tests were conducted to verify that the EMU could sustain a crewman working at system specification work rates while exposed to the environmental conditions of both a dayside and a nightside Earth-orbital EVA. Verifying the ability of the crewman to accomplish a contingency-mode EV transfer between vehicles was also a requirement of this simulation.

The test environment differed somewhat from the anticipated Earth-orbital environment because of the test facility limitations. However, environmental conditions were developed to provide confidence in the ability of the EMU to perform satisfactorily during the Earth-orbital mission. The test environmental conditions were to subject the EMU to the following thermal conditions in a vacuum environment of less than 6.7 mN/m^2 (9.65×10^{-7} psia).

Hot-case conditions: The EMU was subjected to a total absorbed heat load of 1084 ± 88 watts (3700 ± 300 Btu/hr) for a period of at least 3.0 hours. The heat load was distributed such that the ratio of the load on the side facing the source to that on the opposite side was 2.4:1. This condition was imposed with the subject facing the heat source for at least 3.0 hours and facing away from the heat source for at least 3.0 hours.

Cold-case conditions: The EMU was subjected to a total absorbed heat load of 264 ± 59 watts (900 ± 200 Btu/hr) for a period of at least 3.0 hours. The heat load was distributed so that the ratio of the load on the side facing the source of heat to that on the opposite side was at least 3:1. This condition was imposed with the subject facing away from the heat source.

The EMU test performance requirements were as follows.

1. Sufficient cooling shall be provided to accommodate a total metabolic expenditure of 5064 kilojoules (4800 British thermal units) over a 3-hour period.

2. Sufficient cooling shall be provided for crewman metabolic work rates of 586 watts (2000 Btu/hr) for periods of 15 minutes.

3. The crewman shall be protected from thermal shock during periods of varying thermal or metabolic loads.

4. The crewman shall not be subcooled while working at metabolic work rates of 117 watts (400 Btu/hr) for periods of as long as 20 minutes.

5. The local skin temperature shall not exceed 314 K (105° F), and the minimum skin temperature shall not be less than 283 K (50° F). In emergency conditions, the body may be allowed to absorb 129 watts (440 Btu/hr) or to lose 97 watts (330 Btu/hr).

6. The temperature of the ventilating gas at the PGA inlet shall be within the limits of 275 to 303 K (35° to 85° F), and the dewpoint shall be no greater than 286 K (55° F).

7. The CO₂ concentration in the crewman oral-nasal area shall not exceed 1000 N/m² (7.5 torr) during the first 2.5 hours of operation, 1333 N/m² (10.0 torr) for 2.5 to 3.0 hours of operation, or 2000 N/m² (15.0 torr) beyond 3 hours of operation.

8. A sufficient oxygen supply shall be provided to maintain life for 30 minutes in a purge mode requiring an oxygen flow of 3.63 kg/hr (8 lb/hr). The purge mode shall be configured to enable activation by an unassisted crewman during EV operation.

9. Antiglare protection and maintenance of normal vision shall be provided.

10. Satisfactory human factors (reach, mobility, etc.) shall be provided.

On completion of the test, the EMU was qualified for Earth-orbital missions.

Lunar surface demonstration. - A lunar surface functional demonstration was conducted to qualify the EMU for normal mode use in crewman life support during the lunar exploration phase of the Apollo Program. The lunar surface environments, lunar-stay duration, and crewman metabolic loads, as defined in the design reference mission, were simulated. The test was conducted in a thermal-vacuum chamber that was fitted with a means of exercising to obtain metabolic rates while the test crewman was exposed to specific lunar environments. The following tests were conducted.

1. A lunar-plain night test was conducted to demonstrate the ability of the EMU to support the crewman during a lunar-plain night or while working in a shadow.

2. A lunar-plain day test was conducted to demonstrate the capability of the EMU to support the crewman properly during a lunar-plain day with a 33° Sun angle.

3. Lunar-crater day tests were conducted to demonstrate the capability of the EMU to support the crewman properly during a lunar day in a 10:1 aspect-ratio spherical crater with a 33° Sun angle and with a 48° Sun angle.

4. A cold-soak test was conducted to evaluate the ability of the EMU to maintain body temperatures under worst-case cold conditions.

5. A hot-case test was conducted to define the performance envelope during the lunar day in craters with aspect ratios of 10:1, 8:1, 6:1, and 5:1.

The following performance requirements were met.

1. The EMU will support tasks producing metabolic heat loads predicted for lunar surface activities in lunar surface environments.

2. The EMU can be operated by an Apollo crewman satisfactorily for the duration and sequence delineated by the Apollo design reference mission.

3. The thermal protection of the ITMG is adequate to maintain crewman comfort and to maintain the skin temperature of the crewman's hands and feet between 289 and 316 K (60° and 110° F).

CREW SUPPORT EQUIPMENT

Ventilators

Ventilators are portable sources of cryogenic air or oxygen used with suited crewmen. They were used on Project Mercury and the Gemini Program to a lesser degree. The ventilators used in the Apollo Program were used for three distinct purposes.

The Apollo portable oxygen ventilator (POV) (fig. 50) is designed primarily to maintain a crewman or a test subject in a preoxygenated state before launch or altitude testing. Because of the decompression involved, nitrogen must be purged from the subject to avoid the bends, and it is imperative that the subject be maintained in a 100-percent-oxygen environment for several hours before decompression. The POV is a hand-carried, self-contained, life-support unit capable of performing this function while providing some degree of cooling. For training use when altitude will not exceed 3048 meters (10 000 feet), liquid air can be substituted for the liquid oxygen (LOX). There is no change in the requirements of the specification if liquid air is substituted for LOX. The operation of the unit is relatively simple. The LOX or the liquid air is stored in a Dewar flask. A buildup valve allows some liquid to boil, maintaining the pressure at 1034 to 1103 kN/m² (150 to 160 psig). Opening the supply valve allows this pressure to force liquid out the bottom of the Dewar flask into a heat exchanger. The liquid boils and absorbs heat in a series of heat exchangers. A diverter valve alters flow through a heat exchanger to regulate the gas temperature. The gas then is routed to the diffusion pump and exhausted through an ejector into the suit loop. The gas, having achieved a high velocity at the ejector, impinges on the gas in the suit loop, providing the force for a ventilation flow of at least 0.28 m³/min (10.0 scfm). This ventilation flow passes through one of two 1.8-meter (6 foot) long umbilicals to the suited subject. The ventilating flow provides oxygen for breathing and cooling and also absorbs moisture emitted by the subject. The flow returns through the other

umbilical. A PCV maintains a positive pressure of 2.5 kN/m^2 (10 inches of water) by dumping approximately $0.04 \text{ m}^3/\text{min}$ (1.5 cfm). The flow is cooled, dehumidified, and returned to the diffusion pump for reuse.

The open-loop ventilator is similar in operation and function to the POV except that it is used only with helmet and gloves off for cooling purposes. The open-loop ventilator uses liquid air rather than oxygen and weighs 9.53 kilograms (21 pounds) when filled with 0.003 cubic meter (3 liters) of liquid air.

The cryogenic pack (fig. 51) is a liquid-air ventilator housed in the same envelope as the PLSS and worn on the back for mission simulations. The cryogenic pack pressurizes the suit to 17 to 25.5 kN/m^2 (2.5 to 3.7 psi) and operates for 90 minutes on a full charge. The suit interfaces are the same as for an actual PLSS except that the cryogenic pack does not have the water and communication connections. The charged weight, with mockups of the OPS and controls, is approximately 31.75 kilograms (70 pounds).

Mockups

Mockups of flight hardware were used extensively in the development of the EMU for the Apollo Program. Some examples of the uses of mockups are spacecraft fit checks; one-g, 1/6-g, and zero-g vehicle ingress and egress simulations; harness fittings; suit and EMU interface tests; crew training; hardware evaluation; burn tests; vehicle stowage reviews; evaluation of prototypes; administrative demonstrations; and display purposes. Mockups were used for these purposes because either the flight hardware was not delivered or the use of flight hardware was impractical or unnecessary. The weight and the stringent preflight handling requirements of the flight units precluded the use of actual flight hardware in many instances.

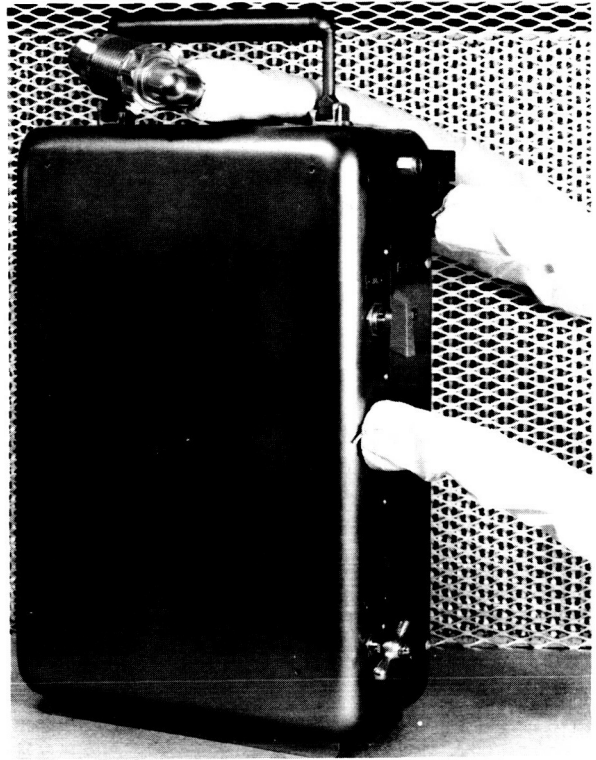

Figure 50. - Portable oxygen ventilator.

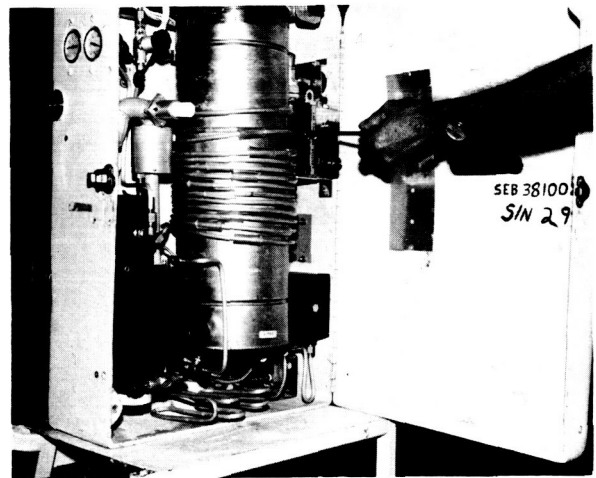

Figure 51. - Cryogenic pack.

The most frequently used mockups were PLSS and OPS controls mockups. The weight of these units was approximately half that of the flight units. The units had envelope dimensions and PGA interfaces identical to the PLSS and the OPS. Also, all crewman and vehicle interfaces (i. e., controls, connectors, and hardpoints) were flight configured. Early in the program, special mockup connectors were built, but actual flight-type connectors were found to be better for training purposes. In addition, the cost of building only one configuration connector (flight type) was less expensive than building two configurations (flight and mockup).

Heavyweight mockups were made by weighting the control mockups. These heavyweight mockups were used for reduced-gravity flights, hardware testing, and crew training.

Three of the early configuration PLSS's were made obsolete by major design changes and were subsequently used for training purposes and as display units. Very early in the program, wooden mockups of batteries and cartridges were used. These were replaced with expended batteries and obsolete cartridges when they became available.

Pad Emergency Air Pack

The pad emergency air pack (PEAP) (fig. 52) is a portable package designed to supply breathing air during emergency egress operations at the launch pad. The surface is contoured to accommodate the upper front part of the torso. The PEAP is designed such that the operations required to connect to the PGA and activate the system are minimal and can be performed by an unassisted crewman using either one or both gloved hands under adverse emergency conditions (including impaired vision). The PEAP provides an airflow into the PGA at a rate sufficient to maintain the CO₂ level within acceptable limits during the evacuation period. The unit consists of an oxygen supply capable of maintaining a gas flow of 0.12178 ± 0.0023 kg/min (0.2685 ± 0.005 lbm/min) at a temperature of 294 K (70° F) and at a regulated pressure of 563 kN/m^2 (81.7 psia) for 4.25 ± 0.25 minutes. Internal suit pressure is maintained by a suit purge valve provided for installation

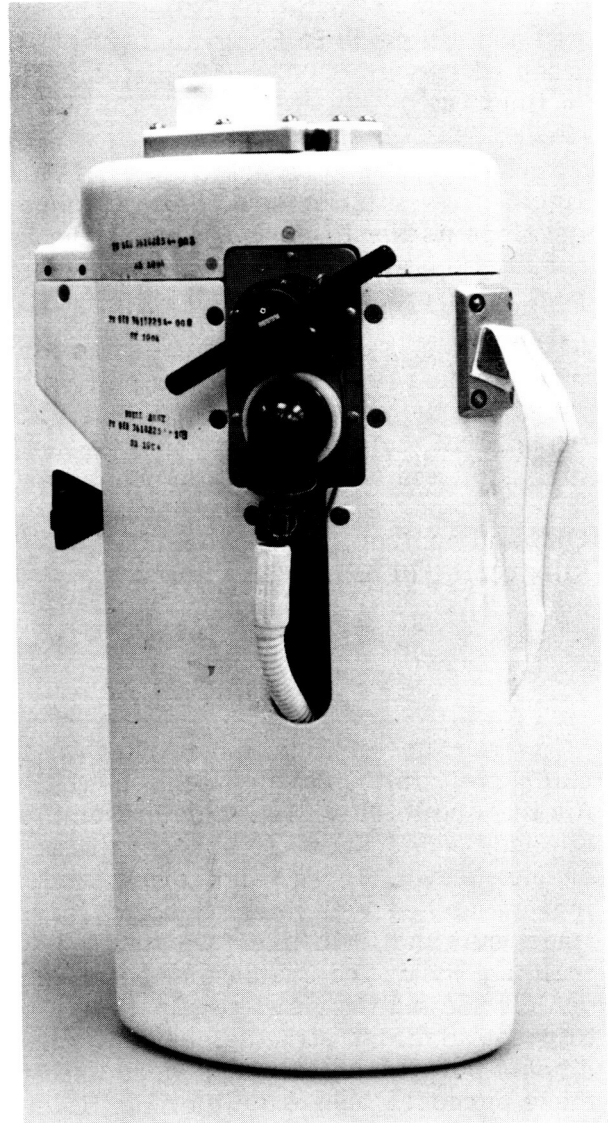

Figure 52. - Pad emergency air pack.

in the PGA outlet gas connector . The purge valve acts as a pressure controller to maintain a suit pressure of 373 N/m^2 (1.5 inches of water) at the specified flow rate. The valve is color coded red. A flexible supply umbilical with a male-type connector is provided to mate with the PGA inlet gas connector receptacles . This connector is color coded blue. The PEAP has an on/off - type valve located on the air pack to control oxygen flow. Stowage points on the pack are used for stowing the supply umbilical and the system purge valve.

CONCLUDING REMARKS

The extravehicular mobility unit was successfully used for the first time during the Apollo 9 Earth-orbital mission. Performance of the hardware was excellent and it was deemed fully acceptable for use on the Apollo 11 mission, the first lunar landing mission.

On July 20, 1969, man took his first step onto the surface of the Moon and collected scientific data while his life was sustained by the extravehicular mobility unit. Throughout the Apollo Program, this unit was used to provide a habitable environment for 16 different crewmen on 7 different missions. It provided more than 160 man-hours of life-supporting environment on the Moon with no significant problems.

The value of the developmental approach used in this program was demonstrated by the successful use of the extravehicular mobility unit on the Apollo 11 mission and all subsequent manned lunar landing missions.

Lyndon B. Johnson Space Center
National Aeronautics and Space Administration
Houston, Texas, March 27, 1975
914-50-80-01-72