



**Specification for the use of
Video and Audio Coding in Broadcasting Applications
based on the MPEG-2 Transport Stream**

**DVB Document A001 Rev. 7
February 2007**

*Reproduction of the document in whole or in part without prior permission of the DVB Project Office is
forbidden.*

Contents

Contents	2
Introduction	8
1 Scope	11
2 References	11
3 Definitions and abbreviations.....	13
3.1 Definitions	13
3.2 Abbreviations.....	15
4 Systems layer	16
4.1 Broadcast bitstreams and Baseline IRDs	16
4.1.1 Introduction (ITU-T Recommendation H.222.0 ISO/IEC 13818-1 Introduction).....	16
4.1.2 Packetized Elementary Stream (PES) (ITU-T Recommendation H.222.0 ISO/IEC 13818-1 clause Intro .4).....	17
4.1.3 Transport stream system target decoder (ITU-T Recommendation H.222.0 ISO/IEC 13818-1 clause 2.4.2)	17
4.1.4 Transport packet layer (ITU-T Recommendation H.222.0 ISO/IEC 13818-1 clause 2.4.3.2)	17
4.1.4.1 Null packets.....	17
4.1.4.2 Transport packet header.....	17
4.1.4.2.1 transport_error_indicator	17
4.1.4.2.2 transport_priority	17
4.1.4.2.3 transport_scrambling_control	17
4.1.4.2.4 Packet IDentifier (PID) values for Service Information (SI) Tables.....	17
4.1.5 Adaptation field (ITU-T Recommendation H.222.0 ISO/IEC 13818-1 clause 2.4.3.4)	18
4.1.5.1 Random_access_indicator	18
4.1.5.2 Elementary_stream_priority_indicator	18
4.1.5.3 Program Clock Reference (PCR).....	18
4.1.5.4 Other fields	19
4.1.6 Packetized Elementary Stream (PES) Packet (ITU-T Recommendation H.222.0 ISO/IEC 13818-1 clause 2.4.3.6)	19
4.1.6.1 stream_id and stream_type	19
4.1.6.2 PES_scrambling_control	20
4.1.6.3 PES_priority	20
4.1.6.4 Copyright and original_or_copy.....	20
4.1.6.5 Trick mode fields.....	20
4.1.6.6 additional_copy_info.....	20
4.1.6.7 Optional fields	21
4.1.6.8 PES_extension_field.....	21
4.1.6.9 Multiple video pictures per PES packet.....	21
4.1.6.10 Presentation Time Stamp and Decoding Time Stamp occurrence.....	22
4.1.7 Program Specific Information (PSI) (ITU-T Recommendation H.222.0 ISO/IEC 13818-1 clause 2.4.4)	23
4.1.8 Program and elementary stream descriptors (ITU-T Recommendation H.222.0 ISO/IEC 13818-1 clause 2.6)	23
4.1.8.1 video_stream_descriptor and audio_stream_descriptor.....	23
4.1.8.2 hierarchy_descriptor	23
4.1.8.3 registration_descriptor	23
4.1.8.4 data_stream_alignment_descriptor	23
4.1.8.5 target_background_grid_descriptor	24
4.1.8.6 video_window_descriptor	24
4.1.8.7 Conditional Access CA_descriptor.....	24
4.1.8.8 ISO_639_Language_descriptor	24
4.1.8.9 system_clock_descriptor	24
4.1.8.10 multiplex_buffer_utilization_descriptor	24
4.1.8.11 copyright_descriptor.....	24
4.1.8.12 maximum_bitrate_descriptor.....	24

4.1.8.13	private_data_indicator_descriptor	25
4.1.8.14	smoothing_buffer_descriptor.....	25
4.1.8.15	STD_descriptor.....	25
4.1.8.16	IBP_descriptor.....	25
4.1.8.17	MPEG-4_audio_descriptor.....	25
4.1.8.18	AVC_video_descriptor.....	25
4.1.8.19	STD audio buffer size.....	25
4.1.8.20	Use of the DVB-SI component_descriptor and multilingual_component_descriptor	26
4.1.8.21	AC-3_descriptor	26
4.1.8.22	Enhanced_AC-3_Descriptor.....	26
4.1.8.23	DTS registration descriptor	26
4.1.8.23.1	descriptor_tag.....	26
4.1.8.23.2	descriptor_length	27
4.1.8.23.3	format_identifier	27
4.1.8.24	DTS_descriptor.....	27
4.1.8.25	AAC_descriptor.....	27
4.1.9	Compatibility with ISO/IEC 11172-1 (ITU-T Recommendation H.222.0 ISO/IEC 13818-1 clause 2.8)	27
4.1.10	Storage Media Interoperability.....	28
4.2	Bitstreams from storage applications and IRDs with digital interfaces	28
4.2.1	Partial Transport Streams	28
4.2.2	Decoding of Trick Play data (ITU-T Recommendation H.222.0 ISO/IEC 13818-1 clause 2.4.3.7)	28
5	Video	29
5.1	25 Hz MPEG-2 SDTV IRDs and Bitstreams.....	29
5.1.1	Profile and level	30
5.1.2	Frame rate	30
5.1.3	Aspect ratio	30
5.1.4	Luminance resolution.....	31
5.1.5	Chromaticity Parameters	32
5.1.6	Chrominance	33
5.1.7	Video sequence header.....	33
5.2	25 Hz MPEG-2 HDTV IRDs and Bitstreams	33
5.2.1	Profile and level	33
5.2.2	Frame rate	33
5.2.3	Aspect ratio	34
5.2.4	Luminance resolution.....	34
5.2.5	Chromaticity Parameters	35
5.2.6	Chrominance	35
5.2.7	Video sequence header.....	35
5.2.8	Backwards Compatibility	35
5.3	30 Hz MPEG-2 SDTV IRDs and Bitstreams.....	35
5.3.1	Profile and level	36
5.3.2	Frame rate	36
5.3.3	Aspect ratio	36
5.3.4	Luminance resolution.....	37
5.3.5	Chromaticity Parameters	38
5.3.6	Chrominance	39
5.3.7	Video sequence header.....	39
5.4	30 Hz MPEG-2 HDTV IRDs and Bitstreams	39
5.4.1	Profile and level	39
5.4.2	Frame rate	39
5.4.3	Aspect ratio	40
5.4.4	Luminance resolution.....	40
5.4.5	Chromaticity Parameters	41
5.4.6	Chrominance	41
5.4.7	Video sequence header.....	41
5.4.8	Backwards Compatibility	41
5.5	Specifications Common to all H.264/AVC IRDs and Bitstreams.....	42
5.5.1	General.....	42
5.5.2	Sequence Parameter Set and Picture Parameter Set.....	42
5.5.2.1	pic_width_in_mbs_minus1 and pic_height_in_map_units_minus1	42

5.5.3	Video Usability Information	43
5.5.3.1	Aspect Ratio Information	43
5.5.3.2	Colour Parameter Information	43
5.5.3.3	Chrominance Information	43
5.5.3.4	Timing Information	43
5.5.3.5	Picture Structure Information	43
5.5.4	Supplemental Enhancement Information	44
5.5.4.1	Picture Timing SEI Message	44
5.5.4.2	Pan-Scan Rectangle SEI Message	44
5.5.4.3	Still pictures	44
5.5.5	Random Access Point	44
5.5.5.1	Time Interval Between RAPs	45
5.6	H.264/AVC SDTV IRDs and Bitstreams	45
5.6.1	Specifications Common to all H.264/AVC SDTV IRDs and Bitstreams	45
5.6.1.1	Sequence Parameter Set and Picture Parameter Set	45
5.6.1.2	Profile and level	46
5.6.1.3	Aspect ratio	46
5.6.2	25 Hz H.264/AVC SDTV IRD and Bitstream	46
5.6.2.1	Colour Parameter Information	46
5.6.2.2	Frame rate	47
5.6.2.3	Luminance resolution	47
5.6.3	30 Hz H.264/AVC SDTV IRD and Bitstream	48
5.6.3.1	Colour Parameter Information	48
5.6.3.2	Frame rate	49
5.6.3.3	Luminance resolution	49
5.7	H.264/AVC HDTV IRDs and Bitstreams	50
5.7.1	Specifications common to all H.264/AVC HDTV IRDs and Bitstreams	50
5.7.1.1	Sequence Parameter Set and Picture Parameter Set	50
5.7.1.2	Profile and level	51
5.7.1.3	Aspect ratio	51
5.7.1.4	Colour Parameter Information	51
5.7.1.5	Luminance resolution	51
5.7.2	25 Hz H.264/AVC HDTV IRD and Bitstream	52
5.7.2.1	Frame rate	52
5.7.2.2	Backwards Compatibility	52
5.7.3	30 Hz H.264/AVC HDTV IRDs and Bitstreams	52
5.7.3.1	Frame rate	52
5.7.3.2	Backwards Compatibility	53
5.8	25 Hz VC-1 SDTV IRDs and Bitstreams	53
5.8.1	Profile, Level and Colour Difference Format	53
5.8.2	Frame rate	53
5.8.3	Aspect ratio	54
5.8.4	Luminance resolution	54
5.8.5	Colour Parameter Information	55
5.8.6	Random Access Point	55
5.9	25 Hz VC-1 HDTV IRDs and Bitstreams	55
5.9.1	Profile, Level and Colour Difference Format	55
5.9.2	Frame rate	56
5.9.3	Aspect ratio	56
5.9.4	Luminance resolution	56
5.9.5	Colour Parameter Information	56
5.9.6	Random Access Point	57
5.9.7	Backwards Compatibility	57
5.10	30 Hz VC-1 SDTV IRDs and Bitstreams	57
5.10.1	Profile and level	57
5.10.2	Frame rate	57
5.10.3	Aspect ratio	58
5.10.4	Luminance resolution	58
5.10.5	Colour Parameter Information	59
5.10.6	Random Access Point	59
5.11	30 Hz VC-1 HDTV IRDs and Bitstreams	59
5.11.1	Profile, Level and Colour Difference Format	59

5.11.2	Frame rate	60
5.11.3	Aspect ratio	60
5.11.4	Luminance resolution	60
5.11.5	Colour Parameter Information	60
5.11.6	Random Access Point	61
5.11.7	Backwards Compatibility	61
6	Audio	61
6.1	MPEG-1 and MPEG-2 backward compatible audio	61
6.1.1	Audio mode	61
6.1.2	Layer	62
6.1.3	Bit rate	62
6.1.4	Sampling frequency	62
6.1.5	Emphasis	63
6.1.6	Cyclic redundancy code	63
6.1.7	Prediction	63
6.1.8	Multilingual	63
6.1.9	Extension Stream	63
6.1.10	Ancillary Data	63
6.2	AC-3 and Enhanced AC-3 audio	64
6.2.1	AC-3 and Enhanced AC-3 PES constraints	64
6.2.1.1	Encoding	64
6.2.1.2	Decoding	64
6.2.1.3	Byte-alignment	65
6.2.2	Enhanced AC-3 with multiple independent substreams – PES constraints	65
6.2.2.1	Encoding	65
6.2.2.2	Decoding	66
6.3	DTS audio	66
6.3.1	DTS PES Constraints	66
6.3.1.1	Encoding	66
6.3.1.2	Decoding	67
6.3.1.3	Byte-alignment	67
6.4	MPEG-4 AAC, MPEG-4 HE-AAC and MPEG-4 HE-AAC v2 audio	67
6.4.1	LATM/LOAS formatting	67
6.4.2	Profiles and Levels	68
6.4.3	Dynamic Range Control	69
Annex A (informative): Examples of Full screen luminance resolutions for SDTV and HDTV		70
Annex B (informative): Auxiliary Data in the Video Elementary Stream		72
B.1	Overview	72
B.2	Common Syntax and Semantics	72
B.3	Active Format Description (AFD)	73
B.3.1	Coded Frame in MPEG-2 Video	73
B.3.2	Coded Frame in H264/AVC Video	74
B.3.3	Coded Frame in VC-1 Video	74
B.3.4	Common Semantics of AFD	74
B.3.5	Relationship with Pan Vectors	77
B.4	Bar data	77
B.4.1	Recommended Receiver Response to Bar Data	78
B.4.2	Relationship Between Bar Data and AFD	78
B.5	Closed Captions	79
B.5.1	Syntax and Semantics of cc_data()	79
B.6	Auxiliary Data and MPEG-2 video	79
B.6.1	Coding	79
B.6.2	Syntax and Semantics	80
B.7	Auxiliary Data and H264/AVC video	80
B.7.1	Coding	80

B.7.2	Syntax and Semantics	81
B.8	Auxiliary Data and VC-1 video	81
B.8.1	Coding	81
B.8.2	Syntax and Semantics	81
B.9	Relationship with Wide Screen Signalling (WSS).....	82
B.10	Aspect Ratio Ranges	82
Annex C (informative): Implementation of Ancillary Data for MPEG Audio		83
C.1	Scope	83
C.2	Introduction	83
C.3	DVB Compliance	83
C.4	Detailed specification for MPEG1 and MPEG2	83
C.4.1	DVD-Video Ancillary Data	83
C.4.2	Extended ancillary data syntax	84
C.4.2.1	ancillary_data_sync.....	85
C.4.2.2	bs_info.....	85
C.4.2.3	mpeg_audio_type	85
C.4.2.4	dolby_surround_mode.....	85
C.4.2.5	ancillary_data_bytes.....	85
C.4.2.6	ancillary_data_status	86
C.4.2.7	advanced_dynamic_range_control	86
C.4.2.8	dialog_normalization.....	86
C.4.2.8.1	dialog_normalization_on	87
C.4.2.8.2	dialog_normalization_value	87
C.4.2.9	reproduction_level.....	87
C.4.2.9.1	surround_reproduction_level.....	87
C.4.2.9.2	production_roomtype	87
C.4.2.9.3	reproduction_level_value	88
C.4.2.10	downmixing_levels_MPEG2	88
C.4.2.10.1	center_mix_level_on	88
C.4.2.10.2	surround_mix_level_on.....	88
C.4.2.10.3	mix_level_value	88
C.4.2.11	audio_coding_mode	89
C.4.2.11.1	compression_on.....	89
C.4.2.12	compression_value.....	89
C.4.2.13	coarse_grain_timecode.....	89
C.4.2.14	fine_grain_timecode.....	90
C.4.2.15	scale_factor_CRC	90
C.4.2.16	Announcement Switching Data.....	90
C.4.2.17	Scale Factor Error Check	91
C.4.2.18	RDS data via UECP protocol.....	91
C.5	Detailed specification for MPEG-4 Audio.....	92
C.5.1	Transmission of MPEG-4 Audio ancillary data.....	92
C.5.2	MPEG4 ancillary data syntax	93
C.5.2.1	ancillary_data_sync.....	93
C.5.2.2	bs_info.....	93
C.5.2.2.1	mpeg_audio_type	93
C.5.2.2.2	dolby_surround_mode.....	94
C.5.2.3	ancillary_data_status	94
C.5.2.4	downmixing_levels_MPEG4	94
C.5.2.4.1	center_mix_level_on	95
C.5.2.4.2	surround_mix_level_on.....	95
C.5.2.4.3	mix_level_value	95
C.5.2.5	audio_coding_mode	95
C.5.2.5.1	compression_on.....	96
C.5.2.5.2	compression_value	96
C.5.2.6	coarse_grain_timecode.....	96

C.5.2.7	fine_grain_timecode.....	96
C.5.3	Announcement Switching Data	96
Annex D (informative): Coding of Data Fields in the Private Data Bytes of the Adaptation Field		98
D.1	Introduction	98
D.2	Detailed specification.....	98
D.2.1	Announcement Switching Data	99
D.2.2	AU_information.....	99
Annex E (informative): Receiver-Mixed Audio Description and other supplementary Audio Services		104
E.1	Overview	104
E.2	Coding.....	104
E.2.1	Syntax and Semantics	105
E.3	Decoder behaviour	107
E.4	Decoder user indicators.....	107
Annex F (informative): Encoding Guidelines to Enable Trick Play Support of H.264/AVC Streams		108
F.1	Introduction	108
F.1.1	Overview	108
F.1.2	Technical Requirements	108
F.2	Discardable Pictures.....	108
F.2.1	MPEG-2 Discardable Pictures	109
F.2.2	H.264/AVC Discardable Pictures	110
F.2.3	Discardable Pictures and Trick Play Speeds.....	110
F.2.4	Smooth Trick Play and Compression Efficiency	111
F.2.5	Impact of Adaptive Encoding on Guidelines.....	112
Annex G (informative): Bibliography.....		113

Introduction

The present document presents guidelines covering coding and decoding using the MPEG-2 system layer, video coding and audio coding.

The guidelines presented in the present document for the Integrated Receiver-Decoder (IRD) are intended to represent a minimum functionality that all IRDs of a particular class are required to either meet or exceed. It is necessary to specify the minimum IRD functionality for basic parameters, if broadcasters are not to be prevented from ever using certain features. For example, if a significant population of IRDs were produced that supported only the Simple Profile, broadcasters would never be able to transmit Main Profile bit-streams.

IRDs are classified in five dimensions as:

- "25 Hz" or "30 Hz", depending on whether the nominal video frame rates based on 25 Hz or 30 000/1 001 Hz (approximately 29,97 Hz) are supported. It is expected that 25 Hz IRDs will be used in those countries where the existing analogue TV transmissions use 25 Hz frame rate and 30 Hz IRDs will be used in countries where the analogue TV transmissions use 30 000/1 001 Hz frame rate. There are also likely to be "dual-standard" IRDs which have the capabilities of both 25 Hz and 30 Hz IRDs.
- "SDTV" or "HDTV", depending on whether or not they are limited to decoding pictures of conventional TV resolution. The capabilities of an SDTV IRD are a sub-set of those of an HDTV IRD.
- "with digital interface" or "Baseline", depending on whether or not they are intended for use with a digital bitstream storage device such as a digital VCR. The capabilities of a Baseline IRD are a sub-set of those of an IRD with digital interface.
- MPEG-2 video, H.264/AVC or VC-1 video coding formats.
- Audio coding formats according to clause 6.

To give a complete definition of an IRD, all five dimensions need to be specified, e.g.:

- 25 Hz SDTV Baseline IRD MPEG-2 video, 25 Hz SDTV Baseline IRD MPEG-2 video, MPEG-1 Layer 2 audio, for an IRD able to decode 720×576 interlaced 25 Hz video pictures.
- 30 Hz HDTV Baseline IRD H264/AVC video, HE AAC Level 4 audio, for an IRD able to decode up to 1920×1080 interlaced 30 Hz video pictures or 1280×720 progressive 60 Hz video pictures.

All the formats supported by an IRD conforming to this specification are listed in annex A.

It should be noted that in DVB systems the source picture format, encoded picture format and display picture format do not need to be identical. For example, HDTV source material may be broadcast as an SDTV bitstream after down-conversion to SDTV resolution and encoding within the constraints of MPEG-2 video Main Profile at Main Level. The IRD receiving the bitstream may then up-convert the decoded picture for display at HDTV resolution.

Another notable feature of the DVB system is that a single Transport Stream may contain programme material intended for more than one type of IRD. A typical example of this is likely to be the simulcasting of SDTV and HDTV video material. In this case an SDTV IRD will decode and display SDTV pictures whilst an HDTV IRD will decode and display HDTV pictures from the same Transport Stream.

Where a feature described in the present document is mandatory, the word "shall" is used and the text is in *italics*; all other features are optional. The functionality is specified in the form of constraints on MPEG-2 systems, video and audio formats which the IRDs are required to decode correctly.

The specification of these baseline features in no way prohibits IRD manufacturers from including additional features, and should not be interpreted as stipulating any form of upper limit to the performance. The guidelines do not cover features, such as the IRDs up-sampling filter, which affect the quality of the displayed picture rather than whether the IRD is able to decode pictures at all. Such issues are left to the marketplace.

The guidelines presented for IRDs observe the following principles:

- wherever practical, IRDs should be designed to allow for future compatible extensions to the bit-stream syntax;
- all "reserved" and "private" bits in MPEG-2 systems, video and audio formats should be ignored by IRDs not designed to make use of them.

The rules of operation for the encoders are features and constraints which the encoding system should adhere to in order to ensure that the transmissions can be correctly decoded. These constraints may be mandatory or optional. Where a feature or constraint is mandatory, the word "shall" is used and the text is italic; all other features are optional.

Clauses 4 to 6 and the annexes, provide the guidelines for the Digital Video Broadcasting (DVB) systems layer, video, and audio respectively. For information, some of the key features are summarized below, but clauses 4 to 6 and the annexes should be consulted for all definitions:

Systems:

- MPEG-2 Transport Stream (TS) is used;
- Service Information (SI) is based on MPEG-2 program-specific information;
- Scrambling is as defined in ETR 289 [5];
- Conditional access uses the MPEG-2 Conditional Access CA_descriptor;
- Partial Transport Streams are used for digital VCR applications.

Video:

- MPEG-2 Main Profile at Main Level is used for MPEG-2 encoded SDTV;
- MPEG-2 Main Profile at High Level is used for MPEG-2 encoded HDTV;
- H.264/AVC Main Profile at Level 3 is used for H.264/AVC SDTV;
- H.264/AVC High Profile at Level 4 is used for H.264/AVC HDTV;
- VC-1 Advanced Profile at Level 1 is used for VC-1 SDTV;
- VC-1 Advanced Profile at Level 3 is used for VC-1 HDTV;
- The 25 Hz MPEG-2 SDTV IRD, 25 Hz H.264/AVC SDTV IRD and 25 Hz VC-1 SDTV IRD support 25 Hz frame rate;
- The 25 Hz MPEG-2 HDTV IRD, 25 Hz H.264/AVC HDTV IRD and 25 Hz VC-1 HDTV IRD support frame rates of 25 Hz or 50 Hz;
- The 30 Hz MPEG-2 SDTV IRD, 30 Hz H.264/AVC SDTV IRD and 30 Hz VC-1 SDTV IRD support frame rates of 24 000/1 001, 24, 30 000/1 001 and 30 Hz;
- The 30 Hz MPEG-2 HDTV IRD, 30 Hz H.264/AVC HDTV IRD and 30 Hz VC-1 HDTV IRD supports frame rates of 24 000/1 001, 24, 30 000/1 001, 30, 60 000/1 001 and 60 Hz;
- SDTV pictures may have either 4:3, 16:9 or 2.21:1 aspect ratio; IRDs support 4:3 and 16:9 and optionally 2.21:1 aspect ratio;
- MPEG-2 HDTV pictures have 16:9 or 2.21:1 aspect ratio; IRDs support 16:9 and optionally 2.21:1 aspect ratio;
- H.264/AVC HDTV pictures have 16:9 aspect ratio ; IRDs support 16:9 aspect ratio;
- VC-1 HDTV pictures have 16:9 aspect ratio ; IRDs support 16:9 aspect ratio;
- MPEG-2 IRDs support the use of pan vectors to allow a 4:3 monitor to give a full-screen display of a 16:9 coded picture of SDTV resolution;

- IRDs may also optionally support the use of the Active Format Description (refer to annex B of the present document) as part of the logic to control the processing and positioning of the reconstructed image for display.

Audio:

- Audio content complies with MPEG-1 Layer I, MPEG-1 Layer II, MPEG-2 Layer II backward compatible, AC-3, Enhanced AC-3, DTS, MPEG-4 AAC, MPEG-4 HE-AAC or MPEG-4 HE-AACv2 audio;
- Sampling rates of 32 kHz, 44,1 kHz and 48 kHz are supported by IRDs;
- The encoded bit-stream does not use emphasis;
- IRDs may also optionally support full multi-channel decoding of MPEG-2 Layer II backwards compatible multi-channel audio;
- The use of Layer II encoding is recommended for MPEG-1 audio bit-streams;
- IRDs may also optionally support the decoding of MPEG audio streams which include ancillary data (see Annex C);
- IRDs may also optionally support receiver-mixed audio (see Annex E).

1 Scope

The present document provides implementation guidelines for the use of audio-visual coding in satellite, cable and terrestrial broadcasting distribution systems that utilize MPEG-2 Systems. Both Standard Definition Television (SDTV) and High Definition Television (HDTV) are covered. MPEG-2, H.264/AVC and VC-1 video coding systems are covered. MPEG-1/MPEG-2 Layer II, Dolby AC-3, Enhanced AC-3, DTS, MPEG-4 HE AAC and MPEG-4 HE AAC v2 audio coding systems are covered. Guidelines for devices equipped with a digital interface intended for digital VCR applications are also given in the present document. It does not cover applications such as contribution services which are likely to be the subject of subsequent "Guidelines" documents.

The rules of operation for the encoders are features and constraints which the encoding system should adhere to in order to ensure that the transmissions can be correctly decoded. These constraints may be mandatory, recommended or optional.

2 References

The following documents contain provisions which, through reference in this text, constitute provisions of the present document.

- References are either specific (identified by date of publication and/or edition number or version number) or non-specific.
- For a specific reference, subsequent revisions do not apply.
- For a non-specific reference, the latest version applies.

Referenced documents which are not found to be publicly available in the expected location might be found at <http://docbox.etsi.org/Reference>.

- [1] ITU-T Recommendation H.222.0 | ISO/IEC 13818-1 (2000): "Information Technology - Generic Coding of moving pictures and associated audio information: Systems" - and ITU-T Recommendation H.222.0 | Amendment 3 (2004)/ISO/IEC 13818-1: 2000/Amendment 3:(2004): "Transport of AVC video data over ITU-T Recommendation H.222.0 | ISO/IEC 13818-1 streams".
- [2] ITU-T Recommendation H.262 (2000)/ISO | IEC 13818-2 (2000): "Information Technology - Generic Coding of moving pictures and associated audio information: Video".
- [3] ISO/IEC 13818-3 (1998): "Information technology - Generic coding of moving picture and associated audio information; Part 3: Audio".
- [4] ISO/IEC 13818-9 (1996): "Information technology - Generic coding of moving pictures and associated audio information - Part 9: Extension for real time interface for systems decoders".
- [5] ETSI ETR 289: "Digital Video Broadcasting (DVB); Support for use of scrambling and Conditional Access (CA) within digital broadcasting systems".
- [6] ETSI EN 300 468: "Digital Video Broadcasting (DVB); Specification for Service Information (SI) in DVB systems".
- [7] ETSI ETR 211: "Digital Video Broadcasting (DVB); Guidelines on implementation and usage of Service Information (SI)".
- [8] ISO/IEC 11172-1: "Information Technology - Coding of moving pictures and associated audio for digital storage media up to about 1,5 Mbit/s - Part 1: Systems".
- [9] ISO/IEC 11172-3 (1993): "Information Technology - Coding of moving pictures and associated audio for digital storage media at up to about 1,5 Mbit/s - Part 3: Audio".
- [10] ITU-T Recommendation J.17 (1988): "Pre-emphasis used on sound-programme circuits".

- [11] EBU Recommendation R.68: "Alignment level in digital audio production equipment and in digital audio recorders".
- [12] ETSI TS 102 366: "Digital Audio Compression (AC-3, Enhanced AC-3) Standard".
- [13] ITU-R Recommendation BT.709: "Parameter values for the HDTV standards for production and international programme exchange".
- [14] ETSI EN 300 294: "Television systems; 625-line television Wide Screen Signalling (WSS)".
- [15] ETSI TS 102 114: "DTS Coherent Acoustics; Core and Extensions".
- [16] ITU-T Recommendation H.264 (2005) | ISO/IEC 14496-10:2005: "Information technology - Coding of audio-visual objects- Part 10: Advanced Video Coding".
- [17] ISO/IEC 14496-3: "Information technology -- Coding of audio-visual objects - Part 3: Audio, including amendment 1: "Bandwidth Extension" and amendment 2: "Parametric Coding for High Quality Audio".
- [18] ISO/IEC 13818-1 (2000) Amd 5 (FPDAM): "New audio profile and level signalling and change to audio-type table entry".
- [19] ETSI EN 300 401 (V.1.3.3): "Radio Broadcasting Systems; Digital Audio Broadcasting (DAB) to mobile, portable and fixed receivers".
- [20] ITU-T Recommendation T.35 (2000): "Procedure for the allocation of ITU-T defined codes for non-standard facilities".
- [21] SMPTE 421M (2006): " VC-1 Compressed Video Bitstream Format and Decoding Process".
- [22] SMPTE RP 227 (2006): " VC-1 Bitstream Transport Encodings".
- [23] IEC 62106:1999: "Radio Data System"
- [24] RDS-Forum SPB 490: "RDS Universal Encoder Communication Protocol", Final Version 6.01, June 2003
- [25] SMPTE 2016-1-2006: "Format for Active Format Description and Bar Data".
- [26] CEA-CEB16 (2006): "Active Format Description (AFD) & Bar Data Recommended Practice".
- [27] ITU-R Recommendation BT.1700 (2005): "Characteristics of video signals for conventional analogue television systems".
- [28] CEA-708-C (2006): "Digital Television (DTV) Closed Captioning," Consumer Electronics Association.

3 Definitions and abbreviations

3.1 Definitions

For the purposes of the present document, the following terms and definitions apply:

25 Hz MPEG-2 SDTV IRD: IRD which is capable of decoding and displaying pictures based on a nominal video frame rate of 25 Hz from MPEG-2 Main Profile, Main Level bitstreams as specified in TS 101 154

25 Hz MPEG-2 SDTV Bitstream: bitstream which contains only MPEG-2 Main Profile, Main Level video at 25 Hz frame rate as specified in TS 101 154

25 Hz MPEG-2 HDTV IRD: IRD that is capable of decoding and displaying pictures based on a nominal video frame rate of 25 Hz or 50 Hz from MPEG-2 Main Profile, High Level bitstreams as specified in TS 101 154, in addition to providing the functionality of a 25 Hz SDTV IRD

25 Hz MPEG-2 HDTV Bitstream: bitstream which contains only MPEG-2 Main Profile, High Level (or simpler) video at 25 Hz or 50 Hz frame rates as specified in TS 101 154

30 Hz MPEG-2 SDTV IRD: IRD which is capable of decoding and displaying pictures based on a nominal video frame rate of 24 000/1001 (approximately 23.98), 24, 30000/1001 (approximately 29,97) or 30 Hz from MPEG-2 Main Profile at Main Level bitstreams as specified in TS 101 154

30 Hz MPEG-2 SDTV Bitstream: bitstream which contains only MPEG-2 Main Profile, Main Level video at 24 000/1001, 24, 30000/1001 or 30 Hz frame rate as specified in TS 101 154

30 Hz MPEG-2 HDTV IRD: IRD that is capable of decoding and displaying pictures based on nominal video frame rates of 24 000/1001, 24, 30000/1001, 30, 60/1001 or 60 Hz from MPEG-2 Main Profile, High Level bitstreams as specified in TS 101 154, in addition to providing the functionality of a 30 Hz SDTV IRD

30 Hz MPEG-2 HDTV Bitstream: bitstream which contains only MPEG-2 Main Profile, High Level (or simpler) video at 24 000/1001, 24, 30000/1001, 30, 60/1001 or 60 Hz frame rates as specified in TS 101 154

MPEG-2 IRD: a collective term referring to the 25 Hz MPEG-2 SDTV IRD, 30 Hz MPEG-2 SDTV IRD, 25 Hz MPEG-2 HDTV IRD, 30 Hz MPEG-2 HDTV IRD

MPEG-2 Bitstream: a collective term referring to the 25 Hz MPEG-2 SDTV Bitstream, 30 Hz MPEG-2 SDTV Bitstream, 25 Hz MPEG-2 HDTV Bitstream, 30 Hz MPEG-2 HDTV Bitstream

25 Hz H.264/AVC SDTV IRD: IRD which is capable of decoding and displaying pictures based on a nominal video frame rate of 25 Hz from H.264/AVC Main Profile at Level 3 bitstreams as specified in TS 101 154

25 Hz H.264/AVC SDTV Bitstream: bitstream which contains only H.264/AVC Main Profile at Level 3 video at 25 Hz frame rate as specified in TS 101 154

25 Hz H.264/AVC HDTV IRD: IRD that is capable of decoding and displaying pictures based on a nominal video frame rate of 25 Hz or 50 Hz from H.264/AVC High Profile at Level 4 bitstreams as specified in TS 101 154, in addition to providing the functionality of a 25 Hz H.264/AVC SDTV IRD

25 Hz H.264/AVC HDTV Bitstream: bitstream which contains only H.264/AVC High Profile at Level 4 (or simpler) video at 25 Hz or 50 Hz frame rates as specified in TS 101 154

30 Hz H.264/AVC SDTV IRD: IRD which is capable of decoding and displaying pictures based on a nominal video frame rate of 24 000/1001 (approximately 23.98), 24, 30000/1001 (approximately 29,97) or 30 Hz from H.264/AVC Main Profile at Level 3 bitstreams as specified in TS 101 154

30 Hz H.264/AVC SDTV Bitstream: bitstream which contains only H.264/AVC Main Profile at Level 3 video at 24 000/1001, 24, 30000/1001 or 30 Hz frame rate as specified in TS 101 154

30 Hz H.264/AVC HDTV IRD: IRD that is capable of decoding and displaying pictures based on nominal video frame rates of 24 000/1001, 24, 30000/1001, 30, 60/1001 or 60 Hz from H.264/AVC High Profile at Level 4 bitstreams as specified in TS 101 154, in addition to providing the functionality of a 30 Hz SDTV IRD

30 Hz H.264/AVC HDTV Bitstream: bitstream which contains only H.264/AVC High Profile at Level 4 (or simpler) video at 24 000/1001, 24, 30000/1001, 30, 60/1001 or 60 Hz frame rates as specified in TS 101 154

H.264/AVC SDTV IRD: collective term referring to the 25 Hz H.264/AVC SDTV IRD and the 30 Hz H.264/AVC SDTV IRD

H.264/AVC SDTV Bitstream: collective term referring to the 25 Hz H.264/AVC SDTV Bitstream and the 30 Hz H.264/AVC SDTV Bitstream

H.264/AVC HDTV IRD: collective term referring to the 25 Hz H.264/AVC HDTV IRD and the 30 Hz H.264/AVC HDTV IRD

H.264/AVC HDTV Bitstream: collective term referring to the 25 Hz H.264/AVC HDTV Bitstream and the 30 Hz H.264/AVC HDTV Bitstream

H.264/AVC IRD: collective term referring to the H.264/AVC SDTV IRD and the H.264/AVC HDTV IRD

H.264/AVC Bitstream: collective term referring to the H.264/AVC SDTV Bitstream and the H.264/AVC HDTV Bitstream

25 Hz VC-1 SDTV IRD: IRD which is capable of decoding and displaying pictures based on a nominal video frame rate of 25 Hz from VC-1 Advanced Profile at Level 1 bitstreams as specified in TS 101 154

25 Hz VC-1 SDTV Bitstream: bitstream which contains only VC-1 Advanced Profile at Level 1 video at 25 Hz frame rate as specified in TS 101 154

25 Hz VC-1 HDTV IRD: IRD that is capable of decoding and displaying pictures based on a nominal video frame rate of 25 Hz or 50 Hz from VC-1 Advanced Profile at Level 3 bitstreams as specified in TS 101 154, in addition to providing the functionality of a 25 Hz VC-1 SDTV IRD

25 Hz VC-1 HDTV Bitstream: bitstream which contains only VC-1 Advanced Profile at Level 3 (or simpler) video at 25 Hz or 50 Hz frame rates as specified in TS 101 154

30 Hz VC-1 SDTV IRD: IRD which is capable of decoding and displaying pictures based on a nominal video frame rate of 24 000/1001 (approximately 23.98), 24, 30000/1001 (approximately 29.97) or 30 Hz from VC-1 Advanced Profile at Level 1 bitstreams as specified in TS 101 154

30 Hz VC-1 SDTV Bitstream: bitstream which contains only VC-1 Advanced Profile at Level 1 video at 24 000/1001, 24, 30000/1001 or 30 Hz frame rate as specified in TS 101 154

30 Hz VC-1 HDTV IRD: IRD that is capable of decoding and displaying pictures based on nominal video frame rates of 24 000/1001, 24, 30000/1001, 30, 60/1001 or 60 Hz from VC-1 Advanced Profile at Level 3 bitstreams as specified in TS 101 154, in addition to providing the functionality of a 30 Hz SDTV IRD

30 Hz VC-1 HDTV Bitstream: bitstream which contains only VC-1 Advanced Profile at Level 3 (or simpler) video at 24 000/1001, 24, 30000/1001, 30, 60/1001 or 60 Hz frame rates as specified in TS 101 154

VC-1 SDTV IRD: collective term referring to the 25 Hz VC-1 SDTV IRD and the 30 Hz VC-1 SDTV IRD

VC-1 SDTV Bitstream: collective term referring to the 25 Hz VC-1 SDTV Bitstream and the 30 Hz VC-1 SDTV Bitstream

VC-1 HDTV IRD: collective term referring to the 25 Hz VC-1 HDTV IRD and the 30 Hz VC-1 HDTV IRD

VC-1 HDTV Bitstream: collective term referring to the 25 Hz VC-1 HDTV Bitstream and the 30 Hz VC-1 HDTV Bitstream

VC-1 IRD: collective term referring to the VC-1 SDTV IRD and the VC-1 HDTV IRD

VC-1 Bitstream: collective term referring to the VC-1 SDTV Bitstream and the VC-1 HDTV Bitstream

I picture: picture (frame or field) containing only intra macroblocks

Baseline IRD: IRD which provides the minimum functionality to decode transmitted bitstreams as recommended in TS 101 154. It is not required to have the ability to decode Partial Transport Streams as may be received from a digital interface connected to digital bitstream storage device such as a digital VCR

IRD with Digital Interface: IRD which has the ability to decode Partial Transport Streams received from a digital interface connected to digital bitstream storage device such as a digital VCR as specified in TS 101 154, in addition to providing the functionality of a Baseline IRD

Pan Vector: horizontal offset in video frame centre position specified by non zero value in the frame_centre_horizontal_offset field in the MPEG video stream

Partial Transport Stream: bitstream derived from an MPEG-2 Transport Stream by removing those Transport Stream Packets that are not relevant to one particular selected programme, or a number of selected programmes

H.264/AVC RAP: access unit with AU delimiter in an H.264/AVC Bitstream at which an IRD can begin decoding video successfully. This access unit shall include exactly one Sequence Parameter Set (that is active) with VUI and the Picture Parameter Set that is required for decoding the associated picture. The SPS shall also precede any SEI NAL units in this access unit. This access unit must contain an IDR picture or an I picture

H.264/AVC GOP: A collection of H.264/AVC Access Units (AUs) starting at, and including the AU comprising the H.264/AVC RAP, and including all the AUs upto, but not including the next AU that is an H.264/AVC RAP.

VC-1 Access Point: access unit in a VC-1 Bitstream at which an IRD can begin decoding video successfully. This access unit must contain a sequence header and can have no decoding dependence on any data preceding this point.

3.2 Abbreviations

For the purposes of the present document, the following abbreviations apply:

AAC	Advanced Audio Coding according to ISO/IEC 14496-3 [17]
AC-3	Dolby AC-3 audio coding system according to TS 102 366 [12]
AFD	Active Format Description
AOT	Audio Object Type
AVC	Advanced Video Coding
CA	Conditional Access
DAB	Digital Audio Broadcasting
DRC	Dynamic Range Control, as defined in ISO/IEC 14496-3 [17]
DTS	DTS audio coding system according to TS 102 114 [15]
DVB	Digital Video Broadcasting
DVD	Digital Versatile Disc
ES	Elementary Stream
ESCR	Elementary Stream Clock Reference
H.264/AVC	Advanced Video Coding for Generic Audiovisual Services according to ITU-T Recommendation H.264 [16]
HDTV	High Definition Television
HE AAC	High-Efficiency Advanced Audio Coding according to ISO/IEC 14496-3 [17]
IDR	Instantaneous Decoding Refresh, as defined in ITU-T Recommendation H.264 [16]
I-frame	Intra-coded frame
IRD	Integrated Receiver-Decoder
LATM	Low overhead Audio Transport Multiplex
LOAS	Low Overhead Audio Stream
MPEG	Moving Pictures Experts Group
NIT	Network Information Table
PAT	Program Association Table
PCR	Program Clock Reference
PES	Packetized Elementary Stream
PID	Packet Identifier
PMT	Program Map Table
PPS	Picture Parameter Set, as defined in ITU-T Recommendation H.264 [16]
PS	Parametric Stereo
PSI	Program Specific Information
RAP	Random Access Point
RDS	Radio Data System
SBR	Spectral Band Replication
ScF-CRC	Scale Factor Cyclic Redundancy Check
SDTV	Standard Definition Television

SEI	Supplemental Enhancement Information
SI	Service Information
SPS	Sequence Parameter Set, as defined in ITU-T Recommendation H.264 [16]
STD	System Target Decoder
TS	Transport Stream
TSDT	Transport Stream Description Table
T-STD	Transport stream System Target Decoder
UECP	Universal Encoder Communication Protocol
VC-1	Advanced Video Coding according to SMPTE Standard 421M [21]
VCR	Video Cassette Recorder
VUI	Video Usability Information

4 Systems layer

This clause describes the guidelines for encoding the systems layer of MPEG-2 in DVB broadcast bit-streams, and for decoding this layer in the IRD. The source bitstream may be transmitted via a satellite, cable or terrestrial channel, or via a digital interface. Clause 4.1 applies to the encoding of all source bitstreams and their decoding by a Baseline IRD. Clause 4.2 gives specific information relating to bitstreams transmitted via a digital interface intended for VCR applications and decoding by IRDs equipped with such an interface.

4.1 Broadcast bitstreams and Baseline IRDs

The multiplexing of baseband signals and associated data conforms to ITU-T Recommendation H.222.0 | ISO/IEC 13818-1 [1]. Some of the parameters and fields are not used in the DVB System and these restrictions are described below.

To allow full compliance to ITU-T Recommendation H.222.0 | ISO/IEC 13818-1 [1] and upward compatibility with future enhanced versions, a DVB IRD shall be able to skip over data structures which are currently "reserved", or which correspond to functions not implemented by the IRD. As an example of this capability, a descriptor tag not yet defined within the DVB System shall be interpreted as a no-action tag, its length field correctly decoded and subsequent data skipped.

For the same reason, IRD design should be made under the assumption that any legal structure as permitted by ITU-T Recommendation H.222.0 | ISO/IEC 13818-1 [1] may occur in the broadcast stream even if presently reserved or unused. Therefore the following is assumed:

- private data shall only be acted upon by decoders which are so enabled;
- filling out the bit-stream shall be carried out using the normal stuffing mechanism. Reserved fields shall not be used for this purpose. Data of reserved fields shall be set to 0xFF.

The headings in this clause are based on ITU-T Recommendation H.222.0 | ISO/IEC 13818-1 [1]. The numbers in brackets after the headings are the relevant chapter and clause headings of ITU-T Recommendation H.222.0 | ISO/IEC 13818-1 [1].

4.1.1 Introduction (ITU-T Recommendation H.222.0 | ISO/IEC 13818-1 Introduction)

MPEG-2 systems specify two types of multiplexed data stream: the transport stream and the program stream.

Encoding: *The transmitted multiplex shall use the transport stream.*

Decoding: *All Baseline IRDs shall be able to demultiplex the MPEG-2 transport stream. Demultiplexing of program streams (as described in clauses Intro .2 and Intro .3 of ITU-T Recommendation H.222.0 | ISO/IEC 13818-1 [1]) is optional.*

4.1.2 Packetized Elementary Stream (PES) (ITU-T Recommendation H.222.0 | ISO/IEC 13818-1 clause Intro .4)

Encoding: The creation of a physical Packetized Elementary Stream (PES) by an encoder is not required. ESCR fields and ES rate fields need not be coded.

Decoding: ESCR fields and ES rate fields need not be decoded.

4.1.3 Transport stream system target decoder (ITU-T Recommendation H.222.0 | ISO/IEC 13818-1 clause 2.4.2)

Encoding: *The system clock frequency shall conform to the tolerance specified in clause 2.4.2.1 of ITU-T Recommendation H.222.0 | ISO/IEC 13818-1 [1]. It is recommended that the tolerance is within 5 parts per million.*

Decoding: *The IRD shall operate over the full tolerance range of the system clock frequency specified in clause 2.4.2.1 of ITU-T Recommendation H.222.0 | ISO/IEC 13818-1 [1].*

4.1.4 Transport packet layer (ITU-T Recommendation H.222.0 | ISO/IEC 13818-1 clause 2.4.3.2)

4.1.4.1 Null packets

Encoding: *The encoding of null packets (those with PID value 0x1FFF) shall be as specified in ITU-T Recommendation H.222.0 | ISO/IEC 13818-1 [1].*

4.1.4.2 Transport packet header

4.1.4.2.1 transport_error_indicator

Encoding: It is recommended that any error detecting devices in a transmission path should set the **transport_error_indicator** bit when uncorrectable errors are detected.

Decoding: Whenever the **transport_error_indicator** flag is set in the transmitted stream it is recommended that the IRD should then invoke a suitable concealment or error recovery mechanism.

4.1.4.2.2 transport_priority

Decoding: The **transport_priority** bit has no meaning to the IRD, and may be ignored.

4.1.4.2.3 transport_scrambling_control

Encoding: *The transport_scrambling_control bits shall be set according to Table 1, in accordance with ETR 289 [5].*

Table 1: Coding of transport_scrambling_control bits

Value	Description
00	no scrambling of TS packet payload
01	reserved for future DVB use
10	TS packet scrambled with Even key
11	TS packet scrambled with Odd key

Decoding: *These bits shall be read by the IRD, and the IRD shall respond in accordance with Table 1.*

4.1.4.2.4 Packet Identifier (PID) values for Service Information (SI) Tables

Encoding: The assignment of PID values for SI data is given in EN 300 468 [6].

4.1.5 Adaptation field (ITU-T Recommendation H.222.0 | ISO/IEC 13818-1 clause 2.4.3.4)

4.1.5.1 Random_access_indicator

For MPEG-2 Video Bitstreams, the following applies.

Encoding: It is recommended that the **random_access_indicator** bit is set whenever a random access point occurs in video streams (i.e. video sequence header immediately followed by an I-frame).

For H.264/AVC Bitstreams, the following applies.

Encoding: *The **random_access_indicator** bit shall be set whenever an H.264/AVC RAP occurs in video streams (see H.264/AVC RAP definition in clauses 3.1 and 5.5.5).*

Decoding: The **random_access_indicator** bit may be ignored by the IRD. It can be beneficially utilized together with the **elementary_stream_priority** indicator to identify RAP.

For VC-1 Bitstreams, the following applies.

Encoding: *The **random_access_indicator** bit shall be set whenever a VC-1 Access Point occurs in video streams (see **random_access_indicator** and VC-1 Access Point definitions in SMPTE RP 227 [22]).*

Decoding: The **random_access_indicator** bit may be ignored by the IRD. It can be beneficially utilized together with the **elementary_stream_priority** indicator to identify a VC-1 Access Point.

4.1.5.2 Elementary_stream_priority_indicator

For MPEG-2 Video Bitstreams, the following applies:

Decoding: The **elementary_stream_priority_indicator** bit may be ignored by the IRD.

For H.264/AVC Bitstreams, the following applies:

Encoding: *The **elementary_stream_priority_indicator** bit shall be set only when an access unit containing an I or IDR picture (slice_type 0x02 or 0x07) is present in H264/AVC video streams.*

NOTE: The **elementary_stream_priority_indicator** shall be set in the adaptation header of the transport packet that contains the first slice start code of this I or IDR picture (per ISO/IEC 13818-1 [1]). This adaptation header may be in the transport packet immediately after the packet containing the **random_access_indicator**.

Decoding: The **elementary_stream_priority_indicator** bit may be ignored by the IRD. It can be beneficially utilized to support trick modes.

For VC-1 Bitstreams, the following applies:

Encoding: *The **elementary_stream_priority_indicator** bit shall be set only when an access unit containing an I picture is present in VC-1 video streams (see **elementary_stream_priority_indicator** definition in SMPTE RP 227 [22]).*

Decoding: The **elementary_stream_priority_indicator** bit may be ignored by the IRD. It can be beneficially utilized to support trick modes.

4.1.5.3 Program Clock Reference (PCR)

Encoding: *The time interval between two consecutive PCR values of the same program shall not exceed 100 ms as specified in clause 2.7.2 of ITU-T Recommendation H.222.0 | ISO/IEC 13818-1 [1].*

Decoding: *The IRD shall operate correctly with PCRs for a program arriving at intervals not exceeding 100 ms.*

4.1.5.4 Other fields

This clause covers the following fields:

- `original_program_clock_reference_base`;
- `original_program_clock_reference_extension`;
- `splice_countdown`;
- `private_data_byte`;
- `adaptation_field_extension` (including fields within).

Encoding: These fields are optional in a DVB bit-stream. *The flags that indicate the presence or absence of each of these fields shall be set appropriately.*

NOTE: *The usage of `private_data_byte` should comply with Annex D of this specification.*

Decoding: *IRDs shall be able to accept bit-streams which contain these fields.* IRDs may ignore the data within the fields.

4.1.6 Packetized Elementary Stream (PES) Packet (ITU-T Recommendation H.222.0 | ISO/IEC 13818-1 clause 2.4.3.6)

4.1.6.1 `stream_id` and `stream_type`

Encoding: *Elementary streams shall be identified by `stream_id` and `stream_type` in accordance with ITU-T Recommendation H.222.0 | ISO/IEC 13818-1 [1], tables 2-18 and 2-29.*

For VC-1 Bitstreams, the following applies:

Encoding: *Elementary streams shall be identified by **`stream_id`** (with the extension mechanism) and **`stream_type`** in accordance with SMPTE RP 227 [22].*

NOTE: *For VC-1 Bitstreams, the value of **`stream_type`** shall be set to 0xEA.*

Decoding: *IRDs shall be able to accept bitstreams which contain these encoded values.*

For MPEG-4 AAC, MPEG-4 HE AAC and MPEG-4 HE-AAC v2 audio streams, the following applies:

Encoding: *The value of the **`stream_id`** field for LATM/LOAS formatted MPEG-4 AAC, MPEG-4 HE AAC and MPEG-4 HE AAC v2 packetized elementary streams shall be 110x xxxx, where each x can be either 0, or 1. The value of **`stream_type`** for MPEG-4 AAC, MPEG-4 HE AAC and MPEG-4 HE AAC v2 packetized elementary streams shall be 0x11 (indicating ISO/IEC 14496-3 [17] Audio with the LATM transport syntax).*

Decoding: *This field shall be read by the IRD, and the IRD shall interpret this field in accordance with MPEG systems syntax.*

For AC-3, Enhanced AC-3 or DTS audio streams, the following applies:

Encoding: *AC-3, Enhanced AC-3 and DTS packetized elementary streams shall conform to the requirements of a user private stream type 1, as described in ITU-T Recommendation H.222.0 | ISO/IEC 13818-1 [1]. The value of the **`stream_id`** field for an AC-3, Enhanced AC-3 or DTS elementary stream shall be 0xBD (indicating `private_stream_1`). The recommended value of **`stream_type`** for an AC-3, Enhanced AC-3 or DTS elementary stream shall be 0x06 (indicating PES packets containing private data). Multiple AC-3, Enhanced AC-3 or DTS streams may share the same value of **`stream_id`** since each stream is carried with a unique PID value. The mapping of values of PID to **`stream_type`** is indicated in the transport stream Programme Map Table (PMT).*

Decoding: *These fields shall be read by the IRD, and the IRD shall interpret these fields in accordance with MPEG systems syntax.*

4.1.6.2 PES_scrambling_control

Encoding: *The PES_scrambling_control bits shall be set according to Table 2, in accordance with ETR 289 [5].*

Table 2: Coding of PES_scrambling_control bits

Value	Description
00	no scrambling of PES packet payload
01	reserved for future DVB use
10	PES packet scrambled with Even key
11	PES packet scrambled with Odd key

Decoding: *The PES_scrambling_control bits shall be read by the IRD, and the IRD shall respond in accordance with Table 2.*

4.1.6.3 PES_priority

Decoding: The **PES_priority** bit may be ignored by the IRD.

4.1.6.4 Copyright and original_or_copy

Encoding: The copyright and **original_or_copy** bits may be set as appropriate.

Decoding: The IRD need not interpret these bits. *The setting of these bits shall not be altered in any digital output from the IRD.*

4.1.6.5 Trick mode fields

This clause covers the following fields:

- trick_mode_control;
- field_id;
- intra_slice_refresh;
- frequency_truncation;
- field_rep_cntrl.

Encoding: *These trick mode fields shall not be transmitted in a broadcast bit-stream. Bit-streams for other applications (e.g. for non-broadcast interactive services, storage applications, etc.) may use these fields.*

Decoding: The IRD may skip over any data which is flagged as being in a trick mode, if it does not support decoding of trick modes. If the IRD has a digital interface intended for digital VCR applications, it is recommended that it supports decoding of trick modes as indicated in clause 4.2.2.

4.1.6.6 additional_copy_info

Encoding: This field may be used as appropriate.

Decoding: The IRD need not interpret this field. *The coding of the field shall not be altered in any digital output from the IRD.*

4.1.6.7 Optional fields

This clause covers the following fields:

- ESCR;
- ESCR_extension;
- ES_rate;
- previous_PES_packet_CRC;
- PES_private_data;
- pack_header();
- program_packet_sequence_counter;
- MPEG1_MPEG2_identifier;
- original_stuff_length;
- P-STD_buffer_scale;
- P-STD_buffer_size.

Encoding: These fields are optional in a DVB bit-stream. *The flags that indicate the presence or absence of each of these fields shall be set appropriately.*

Decoding: *The IRD shall be able to accept bit-streams which contain these fields.* The IRD may ignore the data within the fields.

4.1.6.8 PES_extension_field

For MPEG-2 Video Bitstreams and H.264/AVC Bitstreams the **PES_extension_field** data field is currently "reserved".

Encoding: *This extension field shall not be coded unless specified in the future by MPEG.*

Decoding: *The IRD shall be able to accept bit-streams which contain this field.* The IRD may ignore the data within the field.

For VC-1 Bitstreams the **PES_extension_field** data field is used to provide the **stream_id_extension** field which identifies this stream as a VC-1 bitstream.

Encoding: *This extension field shall be coded as defined in SMPTE RP 227[22].*

Decoding: *The IRD shall be able to accept bit-streams which contain this field.*

4.1.6.9 Multiple video pictures per PES packet

For MPEG-2 video bitstreams, while there is no restriction against multiple video pictures in a single PES packet, there may be some MPEG-2 decoders that do not support this.

Encoding: The encoder should not put multiple video pictures in a single PES packet.

Decoding: The IRD may be able to accept and decode bit-streams which contain multiple video pictures in a single PES.

For H.264/AVC bitstreams, multiple video pictures are allowed in a single PES packet.

Encoding: *A PES packet per access unit start shall be sent unless multiple access units can be placed in a single transport packet. In this last case, the encoder may put multiple complete access units in a single PES packet. In applications where the IRD is capable of decoding and displaying bitstreams that contain fractions of access unit, the PES packet may contain fractions of Access Units and encoders are recommended to utilize this option for instance when bitrate savings can be achieved.*

An access unit with H.264/AVC RAP shall be the first access unit in the PES packet (see clause 4.1.5.1) and shall always be preceded by a PES header. Changes to picture size or frame rate cannot occur between access units in the same PES packet. The maximum increment in PTS values between two successive PES packets shall be less than 700 ms with the exception case where video is coded using still pictures where the spacing shall be less than 5 seconds. A single PES packet shall not contain multiple H.264/AVC Still pictures or multiple H.264/AVC RAPs.

NOTE: Usage of multiple pictures per PES packet as per the above represents a very constrained set of conditions under which this may occur. Use of this feature potentially introduces complexity in timing extraction. Therefore, it is recommended that this feature is only used where the consequential bitrate savings are essential and the potential system effects are considered.

Decoding: *The IRD shall support decoding and displaying bitstreams, which contain multiple complete access units in a single PES packet.* It is strongly recommended that the IRD also supports decoding and displaying bitstreams that contain fractions of access units in PES packet.

For VC-1 Bitstreams, multiple video pictures are allowed in a single PES packet.

Encoding: *A PES packet per access unit start shall be sent unless if multiple access units can be placed in a single transport packet. In this last case, the encoder may put multiple complete access units in a single PES packet. In applications where the IRD is capable of decoding and displaying bitstreams that contain fractions of access unit, the PES packet may contain fractions of access units and encoders are recommended to utilize this option for instance when bitrate savings can be achieved.*

An access unit with a VC-1 Access Point shall be the first access unit in the PES packet (see clause 4.1.5.1) and shall always be preceded by a PES header.

NOTE: Usage of multiple pictures per PES packet as per the above represents a very constrained set of conditions under which this may occur. Use of this feature potentially introduces complexity in timing extraction. Therefore, it is recommended that this feature is only used where the consequential bitrate savings are essential and the potential system effects are considered.

Decoding: *The IRD shall support decoding and displaying bitstreams, which contain multiple complete access units in a single PES packet.* It is strongly recommended that the IRD also supports decoding and displaying bitstreams that contain fractions of access units in PES packet.

4.1.6.10 Presentation Time Stamp and Decoding Time Stamp occurrence

For H.264/AVC Bitstreams:

Encoding: *Every PES header shall contain the Presentation Time Stamp and the Decoding Time Stamp (only if it differs from the Presentation Time Stamp) of the first access unit in the PES packet. The start of the first access unit shall occur in the same transport packet as the PES header or the packet of same PID immediately following the packet with the PES header, if the data preceding the access unit start code forces the access unit start code into the next transport packet. When a PES packet contains multiple access units, for any access units following the first access unit in the same PES packet the H.264/AVC syntax elements num_units_in_tick, time_scale, pic_struct (if present), and the value of the H.264/AVC variables TopFieldOrderCnt and BottomFieldOrderCnt of the access unit shall allow the derivation of Presentation Time Stamp and the Decoding Time Stamp for the access unit.*

Decoding: *If Presentation Time Stamp is available and Decoding Time Stamp is not available for the first access unit in the PES packet, the H.264/AVC IRD shall set the Decoding Time Stamp equal to the Presentation Time Stamp (per ISO/IEC 13818-1 [1]). The Presentation Time Stamp and the Decoding Time Stamp of any access units following the first access unit in the same PES packet shall be derived using the H.264/AVC syntax elements num_units_in_tick, time_scale, pic_struct (if present), and the value of the H.264/AVC variables TopFieldOrderCnt and BottomFieldOrderCnt of the access unit.*

NOTE: Within the accuracy of their respective clocks, the Decoding Time Stamp and Presentation Time Stamp shall indicate the same instant in time as the nominal CPB removal time and the DPB output time in the HRD respectively when picture timing SEI information is transmitted (per Subclause 2.4.3.7 of Amendment 3 of ISO/IEC 13818-1 [1]). This ensures consistency between the STD model of ISO/IEC 13818-1 [1] and the HRD model of ITU-T Rec. H.264 | ISO/IEC 14496-10 [16].

4.1.7 Program Specific Information (PSI) (ITU-T Recommendation H.222.0 | ISO/IEC 13818-1 clause 2.4.4)

The data formats for the Transport Stream Description Table (TSDT) and Network Information Table (NIT) in DVB bit-streams are given in EN 300 468 [6]. The present document also defines additional tables for service information which use Program Specific Information (PSI) private_section structure defined in ITU-T Recommendation H.222.0 | ISO/IEC 13818-1 [1].

It is recommended that the Program Association Table (PAT) and Program Map Table (PMT) are repeated with a maximum time interval of 100 ms between repetitions. It is recommended that the Transport Stream Description Table (TSDT) is repeated with a maximum time interval of 10 seconds between repetitions.

4.1.8 Program and elementary stream descriptors (ITU-T Recommendation H.222.0 | ISO/IEC 13818-1 clause 2.6)

4.1.8.1 video_stream_descriptor and audio_stream_descriptor

For MPEG-2 Video bitstreams,

Encoding: *The **video_stream_descriptor** shall be used to indicate video streams containing still picture data, otherwise these descriptors may be used when appropriate. If **profile_and_level_indication** is not present, then the video bit-stream shall comply with the constraints of Main Profile at Main Level. The appropriate **profile_and_level_indication field** shall always be transmitted for Profiles and Levels other than Main Profile at Main Level.*

If the **audio_stream_descriptor** is not present, then the audio bit-stream shall not use sampling frequencies of 16 kHz, 22,05 kHz or 24 kHz, and all audio frames in the stream shall have the same bit rate.

Decoding: The IRD may use these descriptors when present to determine if it is able to decode the streams.

Note: The video_stream_descriptor defined in this section is not applicable to H.264/AVC or VC-1 bitstreams

4.1.8.2 hierarchy_descriptor

Encoding: *The **hierarchy_descriptor** shall be used if, and only if, audio is coded as more than one hierarchical layer.*

4.1.8.3 registration_descriptor

For MPEG-2 Video bitstreams and H.264/AVC:

Encoding: The **registration_descriptor** may be used when appropriate.

Decoding: The IRD need not make use of this descriptor.

For VC-1 Bitstreams, the following applies.

Encoding: *A **registration_descriptor** shall be used for the signalling of VC-1 bitstreams as defined in SMPTE RP 227 [22]. One and only one **registration_descriptor** shall be present.*

Decoding: *The IRD shall decode and process the VC-1 registration descriptor to access information relevant to the encoded bitstream.*

4.1.8.4 data_stream_alignment_descriptor

For MPEG-2 Video bitstreams and H.264/AVC:

Encoding: The **data_stream_alignment_descriptor** may be used when appropriate.

Decoding: The IRD need not make use of this descriptor.

For VC-1 Bitstreams, the following applies.

Encoding: *The **data_stream_alignment_descriptor** shall not be used. See SMPTE RP 227 [22] for a functional equivalent of the **data_stream_alignment_descriptor** that is specific to VC-1 bitstreams.*

4.1.8.5 target_background_grid_descriptor

Encoding: *The **target_background_grid_descriptor** shall be used when the horizontal or vertical resolution is other than 720×576 pixels for a 25 Hz bitstream or is other than 720×480 pixels for a 30 Hz bitstream, otherwise its use is optional.*

Decoding: *If this descriptor is absent, a default grid of 720×576 pixels shall be assumed by a 25 Hz IRD, a default grid of 720×480 pixels shall be assumed by a 30 Hz IRD. The display of correctly windowed video on background grids other than 720×576 pixels is optional for a 25 Hz SDTV IRD, the display of correctly windowed video on background grids other than 720×480 pixels is optional for a 30 Hz SDTV IRD. The HDTV IRD shall read this descriptor, when present, to override the default values.*

4.1.8.6 video_window_descriptor

Encoding: The **video_window_descriptor** may be used when appropriate, to indicate the required position of the video window on the screen.

Decoding: *The IRD shall read this descriptor, when present, and position the video window accordingly.*

4.1.8.7 Conditional Access CA_descriptor

Encoding: *The **CA_descriptor** shall be encoded as defined in ETR 289 [5].*

Decoding: *The IRD shall interpret this descriptor as defined in ETR 289 [5].*

4.1.8.8 ISO_639_Language_descriptor

Encoding: *The **ISO_639_Language_descriptor** shall be present if more than one audio (or video) stream with different languages is present within a program. It is optional otherwise. The use of the **ISO_639_Language_descriptor** is recommended for all audio, video and data streams.*

Decoding: *The IRD shall use the data from this descriptor to assist the selection of appropriate audio (or video) stream of program, if more than one stream is available.*

4.1.8.9 system_clock_descriptor

Encoding: It is recommended that the **system_clock_descriptor** is included in the program_info part of the Program Map Table for each program.

Decoding: The IRD need not make use of this descriptor.

4.1.8.10 multiplex_buffer_utilization_descriptor

Encoding: The **multiplex_buffer_utilization_descriptor** may be used when appropriate.

Decoding: The IRD need not make use of this descriptor.

4.1.8.11 copyright_descriptor

Encoding: The **copyright_descriptor** may be used when appropriate.

Decoding: The IRD need not make use of this descriptor.

4.1.8.12 maximum_bitrate_descriptor

Encoding: The **maximum_bitrate_descriptor** may be used when appropriate.

Decoding: The IRD need not make use of this descriptor.

4.1.8.13 private_data_indicator_descriptor

Encoding: The **private_data_indicator_descriptor** may be used when appropriate.

Decoding: The IRD need not make use of this descriptor.

4.1.8.14 smoothing_buffer_descriptor

Encoding: It is recommended that the **smoothing_buffer_descriptor** is included in the program_info part of the Program Map Table for each program.

Decoding: The IRD need not make use of this descriptor, but the information may be of assistance to digital VCRs.

4.1.8.15 STD_descriptor

Encoding: *The **STD_descriptor** shall be used as specified in ITU-T Recommendation H.222.0 | ISO/IEC 13818-1 [1].*

Decoding: The IRD need not make use of this descriptor.

4.1.8.16 IBP_descriptor

Encoding: The **IBP_descriptor** may be used when appropriate.

Decoding: The IRD need not make use of this descriptor.

4.1.8.17 MPEG-4_audio_descriptor

For MPEG-4 AAC, MPEG-4 HE-AAC and MPEG-4 HE-AAC v2:

Encoding: The **MPEG-4_audio_descriptor** may be used when appropriate.

Decoding: The IRD need not make use of this descriptor.

4.1.8.18 AVC_video_descriptor

For H.264/AVC:

Encoding: The **AVC_video_descriptor** may be used when appropriate. *The **AVC_video_descriptor** shall be used to signal presence of H.264/AVC still pictures within the coded video sequence (see clause 5.5.4.3).*

Decoding: The IRD need not make use of this descriptor. However, the information may assist in support for H.264/AVC still pictures (see clause 5.5.4.3).

4.1.8.19 STD audio buffer size

For AC-3 and Enhanced AC-3:

It is recommended that for AC-3 and Enhanced AC-3 audio in a DVB system, the main audio buffer size (BS_n) has a fixed value of 5 696 bytes.

For MPEG-4 AAC, MPEG-4 HE-AAC and MPEG-4 HE-AAC v2:

It is recommended that for MPEG-4 AAC, MPEG-4 HE AAC and MPEG-4 HE AAC v2 audio in a DVB system, the main audio buffer size (BS_n) has a value of 3 584 bytes for level 2 decoders and 8 976 bytes for level 4 decoders as defined in ITU-T Recommendation H.222.0 | ISO/IEC 13818-1 [1], clause 2.11.2.2.

Refer to ITU-T Recommendation H.222.0 | ISO/IEC 13818-1 [1] for the derivation of (BS_n) for audio elementary streams.

4.1.8.20 Use of the DVB-SI component_descriptor and multilingual_component_descriptor

- Semantics:** The semantics of the **component_descriptor** and **multilingual_component_descriptor** are defined in EN 300 468 [6]. The stream_content and component_type assigned values for DVB AC-3, Enhanced AC-3, MPEG-4 HE AAC, MPEG-4 HE-AAC v2 and DTS audio streams are listed in EN 300 468 [6], table 26.
- Encoding:** *The values for the elements of the component_descriptor and multilingual_component_descriptor shall be set in accordance with EN 300 468 [6].*
- Decoding:** *These fields shall be read by the IRD, and the IRD shall interpret these fields to indicate the type of audio service present.*

4.1.8.21 AC-3_descriptor

- Semantics:** The **AC-3_descriptor** syntax provides information about individual AC-3 elementary streams within a DVB transport stream that are to be identified in the PSI PMT sections. The **AC-3_descriptor** is located in the PMT and the Selection Information Table of the DVB SI Tables defined in EN 300 468 [6] and is defined in EN 300 468 [6], annex D.
- Encoding:** *The AC-3_descriptor shall be included once in a program map section following the relevant ES_info_length field for any AC-3 audio stream coded in accordance with TS 102 366 [12] (not including annex E) that is included in a DVB transport stream.*
- Decoding:** *This descriptor shall be read and interpreted by the IRD.*

4.1.8.22 Enhanced_AC-3_Descriptor

- Semantics:** The **Enhanced_AC-3_descriptor** syntax provides information about individual Enhanced AC-3 elementary streams within a DVB transport stream that are to be identified in the PSI PMT sections. The **Enhanced_AC-3_descriptor** is located in the PMT and the Selection Information Table of the DVB SI Tables defined in EN 300 468 [6] and is defined in EN 300 468 [6], annex D.
- Encoding:** *The Enhanced_AC-3_descriptor shall be included once in a program map section following the relevant ES_info_length field for any Enhanced AC-3 audio stream coded in accordance with TS 102 366 [12], annex E that is included in a DVB transport stream.*
- Decoding:** *This descriptor shall be read and interpreted by the IRD.*

4.1.8.23 DTS registration descriptor

The **DTS registration descriptor** is shown in Table 3. It is mandatory that the IRD decodes of the registration descriptor so that the stream is clearly identified as carrying DTS data.

Table 3: DTS registration descriptor

Syntax	Number of Bits	Mnemonic
registration_descriptor(){		
descriptor_tag	8	uimsbf
descriptor_length	8	uimsbf
format_identifier	32	uimsbf
}		

4.1.8.23.1 descriptor_tag

- Encoding:** The registration descriptor tag is an 8-bit field, which identifies each descriptor. The value assigned to the DTS **descriptor_tag** is 0x05.

Decoding: *This field shall be read by the IRD, and the IRD shall interpret this field in accordance with ITU-T Recommendation H.222.0 | ISO/IEC 13818-1 [1].*

4.1.8.23.2 descriptor_length

Semantics: This 8-bit field specifies the total number of bytes of the data portion of the registration descriptor following the byte defining the value of this field. The value assigned to the DTS **registration descriptor_length** is 0x04.

Decoding: *This field shall be read by the IRD, and the IRD shall interpret this field in accordance with ITU-T Recommendation H.222.0 | ISO/IEC 13818-1 [1].*

4.1.8.23.3 format_identifier

Encoding: The SMPTE registered **format_identifier** sets the frame size for the DTS coded stream and is set according to the values as follows;

- DTS **format_identifier** is 0x44545331 ("DTS1") for frame size 512;
- DTS **format_identifier** is 0x44545332 ("DTS2") for frame size 1 024;
- DTS **format_identifier** is 0x44545333 ("DTS3") for frame size 2 048.

Decoding: This field shall be read by the IRD, and the IRD shall interpret this field in accordance with ITU-T Recommendation H.222.0 | ISO/IEC 13818-1 [1].

4.1.8.24 DTS_descriptor

Semantics: The **DTS_descriptor** syntax provides information about individual DTS elementary streams within a DVB transport stream that are to be identified in the PSI PMT sections. The **DTS_descriptor** is located in the PMT and the Selection Information Table of the DVB SI Tables defined in EN 300 468 [6] and is defined in EN 300 468 [6], annex G.

Encoding: *The **DTS_descriptor** shall be included once in a program map section following the relevant ES_info_length field for any DTS audio stream coded in accordance with TS 102 114 [15] that is included in a DVB transport stream.*

Decoding: *This descriptor shall be read and interpreted by the IRD.*

4.1.8.25 AAC_descriptor

Semantics: The MPEG-4 **AAC_descriptor** syntax provides information about individual MPEG-4 AAC, MPEG-4 HE-AAC or HE-AAC v2 elementary streams within a DVB transport stream that are to be identified in the PSI PMT sections. The **AAC_descriptor** is located in the PMT and the Selection Information Table of the DVB SI Tables defined in EN 300 468 [6] and is defined in EN 300 468 [6], annex H.

Encoding: *The **AAC_descriptor** shall be included once in a program map section following the relevant ES_info_length field for any MPEG-4 AAC, MPEG-4 HE-AAC or MPEG-4 HE-AAC v2 audio stream coded in accordance with ISO/IEC 14496-3 [17] that is included in a DVB transport stream.*

Decoding: *This descriptor shall be read and interpreted by the IRD.*

4.1.9 Compatibility with ISO/IEC 11172-1 (ITU-T Recommendation H.222.0 | ISO/IEC 13818-1 clause 2.8)

Decoding: Compatibility with ISO/IEC 11172-1 [8] (MPEG-1 Systems) is optional.

4.1.10 Storage Media Interoperability

It is recommended that the total bitrate of the set of components, associated PMT and PCR packets for an SDTV service anticipated to be recorded by a consumer, should not exceed 9 000 000 bit/s. It is recommended that the total bitrate of the set of components, associated PMT and PCR packets for an HDTV service anticipated to be recorded by a consumer, should not exceed 28 000 000 bit/s.

It is recommended that the parameters `sb_size` and `sb_leak_rate` in the `smoothing_buffer_descriptor` remain constant for the duration of an event. The value of the `sb_leak_rate` should be the peak attained during the event. The `short_smoothing_buffer_descriptor` is defined in EN 300 468 [6] and guidelines for its use are provided in ETR 211 [7].

4.2 Bitstreams from storage applications and IRDs with digital interfaces

This clause covers both the treatment of Partial Transport Streams which result from external program selection and Trick Play information received from a storage device. MPEG-2 PSI and DVB SI Tables for use specifically in storage applications are defined in EN 300 468 [6].

4.2.1 Partial Transport Streams

Partial transport streams for transfer on a digital interface, e.g. for digital VCR applications, have been defined in IEC CD - 100C/1883. A Partial Transport Stream may be created by selection of Transport Stream Packets from one or more program(s), including PSI Packets.

Encoding: *The Partial Transport Stream shall be fully MPEG compliant with reference to MPEG-2 "Extension for Real-Time-Interface for systems decoders" (ISO/IEC 13818-9 [4]).*

Decoding: *Devices equipped with a digital interface intended for digital VCR applications shall accept the bursty character of a Partial Transport Stream with gaps of variable length between the Transport Stream Packets.*

4.2.2 Decoding of Trick Play data (ITU-T Recommendation H.222.0 | ISO/IEC 13818-1 clause 2.4.3.7)

Encoding: *Trick mode operation shall be signalled by use of the `DSM_trick_mode` flag in the header of the video Packetized Elementary Stream (PES) packets. During trick mode playback the storage device shall construct a bitstream which is syntactically and semantically correct, except as outlined in the note below.*

Decoding: *It is recommended that devices decode the `DSM_trick_mode_flag` and the eight bit trick mode field. Devices which decode the trick mode data shall follow the normative requirements detailed in ITU-T Recommendation H.222.0 | ISO/IEC 13818-1 [1], 2 for all values of the `trick_mode_control` field.*

NOTE: Trick Mode Semantic Constraints.

The bitstream delivered to the decoder during trick mode shall comply with the syntax defined in the MPEG-2 standard. However, for the following video syntax elements, semantic exceptions apply in the presence of the `DSM_trick_mode` field:

- `bit_rate`;
- `vbv_delay`;
- `repeat_first_field`;
- `v_axis_positive`;
- `field_sequence`;
- `subcarrier`;

- burst_amplitude;
- subcarrier_phase.

A decoder cannot rely on the values encoded in these fields when in trick mode.

Similarly, for the systems layer, the following semantic exceptions apply in the presence of the DSM_trick_mode field:

- maximum spacing of PSI information may exceed 400 ms;
- maximum spacing of Presentation Time Stamp or Decoding Time Stamp occurrences may exceed 700 ms;
- PES packets may be void of video data to indicate a change in trick mode byte;
- a PES packet void of video data may contain a Presentation Time Stamp to indicate effective presentation time of new trick mode control;
- when trick_mode status is true, the elementary stream buffers in the T-STD may underflow.

5 Video

This clause describes the guidelines for encoding MPEG-2 video, or H.264/AVC video, or VC-1 video in DVB broadcast bit-streams, and for decoding this bit-stream in the IRD.

Clause 5.1 applies to 25 Hz MPEG-2 SDTV IRDs and broadcasts intended for reception by such IRDs.

Clause 5.2 applies to 25 Hz MPEG-2 HDTV IRDs and broadcasts intended for reception by such IRDs.

Clause 5.3 applies to 30 Hz MPEG-2 SDTV IRDs and broadcasts intended for reception by such IRDs.

Clause 5.4 applies to 30 Hz MPEG-2 HDTV IRDs and broadcasts intended for reception by such IRDs.

Clause 5.5 applies to all H.264/AVC IRDs and broadcasts intended for reception by such IRDs.

Clause 5.6 applies to H.264/AVC SDTV IRDs and broadcasts intended for reception by such IRDs.

Clause 5.7 applies to H.264/AVC HDTV IRDs and broadcasts intended for reception by such IRDs.

Clause 5.8 applies to 25 Hz VC-1 SDTV IRDs and broadcasts intended for reception by such IRDs.

Clause 5.9 applies to 25 Hz VC-1 HDTV IRDs and broadcasts intended for reception by such IRDs.

Clause 5.10 applies to 30 Hz VC-1 SDTV IRDs and broadcasts intended for reception by such IRDs.

Clause 5.11 applies to 30 Hz VC-1 HDTV IRDs and broadcasts intended for reception by such IRDs.

To allow full compliance to the MPEG-2, H.264/AVC and VC-1 standards and upward compatibility with future enhanced versions, a DVB IRD shall be able to skip over data structures which are currently "reserved", or which correspond to functions not implemented by the IRD.

This clause is based on ITU-T Recommendation H.262 | ISO/IEC 13818-2 [2], ITU-T Recommendation H.264 | ISO/IEC 14496-10 [16] and SMPTE 421M [21] .

NOTE: The following clauses do not imply that either MPEG-2 video, H.264/AVC video or VC-1 video are mandatory. The codecs that a given IRD supports will define which of the following clauses the IRD shall comply with.

5.1 25 Hz MPEG-2 SDTV IRDs and Bitstreams

The video encoding shall conform to ITU-T Recommendation H.262 | ISO/IEC 13818-2 [2]. Some of the parameters and fields are not used in the DVB System and these restrictions are described below. The IRD design shall be made under the assumption that any legal structure as permitted by ITU-T Recommendation H.262 | ISO/IEC 13818-2 [2] may occur in the broadcast stream even if presently reserved or unused.

5.1.1 Profile and level

Encoding: *Encoded bit-streams shall comply with the Main Profile Main Level restrictions, as described ITU-T Recommendation H.262 | ISO/IEC 13818-2 [2], clause 8.2. The **profile_and_level_indication** is "01001000" or, if appropriate, "Onnnnnnn", where "Onnnnnnn">"01001000", indicating a "simpler" profile or level than Main Profile, Main Level.*

Decoding: *The 25 Hz MPEG-2 SDTV IRD shall support the decoding of Main Profile Main Level bitstreams. Support for profiles and levels beyond Main Profile, Main Level is optional. If the IRD encounters an extension which it cannot decode, such as one whose identification code is Reserved, Picture Sequence Scaleable, Picture Spatial Scaleable or Picture Temporal Scaleable, it shall discard the following data until the next start code (to allow backward compatible extensions to be added in the future).*

5.1.2 Frame rate

Encoding: *The frame rate shall be 25 Hz, i.e. **frame_rate_code** is "0011".*

Still pictures may be encoded by use of a video sequence consisting of a single intra-coded picture (see definition of still pictures in ITU-T Recommendation H.222.0 | ISO/IEC 13818-1 [1], clause 2.1.48).

Decoding: *All 25 Hz MPEG-2 SDTV IRDs shall support the decoding and display of video material with a frame rate of 25 Hz interlaced (i.e. **frame_rate_code** of "0011"). Support of other frame and field rates is optional.*

25 Hz MPEG-2 SDTV IRDs shall be capable of decoding and displaying still pictures, i.e. video sequences consisting of a single intra-coded picture (see definition of still pictures in ITU-T Recommendation H.222.0 | ISO/IEC 13818-1 [1], clause 2.1.48).

5.1.3 Aspect ratio

Encoding: *The source aspect ratio in 25 Hz MPEG-2 SDTV bit-streams shall be either 4:3, 16:9 or 2.21:1. Note that decoding of 2.21:1 aspect ratio is optional for the 25 Hz MPEG-2 SDTV IRD.*

The **aspect_ratio_information** in the sequence header shall have one of the following three values:

- 4:3 aspect ratio source: "0010";
- 16:9 aspect ratio source: "0011";
- 2.21:1 aspect ratio source: "0100".

It is recommended that pan vectors for a 4:3 window are included in the transmitted bit-stream when the source aspect ratio is 16:9 or 2.21:1. *The vertical component of the transmitted pan vector shall be zero.*

If pan vectors are transmitted then the **sequence_display_extension** shall be present in the bit-stream and the **aspect_ratio_information** shall be set to '0010' (4:3 display). The **display_vertical_size** shall be equal to the **vertical_size**. The **display_horizontal_size** shall contain the resolution of the target 4:3 display. The value of the **display_horizontal_size** field may be calculated by the following equation:

$$\text{display_horizontal_size} = \frac{4}{3} \times \frac{\text{horizontal_size}}{\text{source aspect ratio}}$$

Table 4 gives some typical examples:

Table 4: Values for display_horizontal_size

horizontal_size × vertical_size	Source aspect ratio	display_horizontal_size
720 × 576	16:9	540
544 × 576	16:9	408
480 × 576	16:9	360
352 × 576	16:9	264
352 × 288	16:9	264

Decoding: The 25 Hz MPEG-2 SDTV IRD shall be able to decode bit-streams with values of **aspect_ratio_information** of "0010" and "0011", corresponding to 4:3 and 16:9 aspect ratio respectively. If the IRD has a digital interface, this should be capable of outputting bit-streams with aspect ratios which are not directly supported by the IRD to allow their decoding and display via an external unit.

All 25 Hz MPEG-2 SDTV IRDs shall support the use of pan vectors and up sampling to allow a 4:3 monitor to give a full-screen display of a selected portion of a 16:9 coded picture with the correct aspect ratio. IRDs implementing the 2.21:1 aspect ratio should support the use of pan vectors and up sampling to allow a 4:3 monitor to give a full-screen display of a selected portion of the 2.21:1 picture with the correct aspect ratio. Support for pan vectors with non-zero vertical components is optional. When no pan vectors are present in the transmitted bit-stream, the central portion of the wide-screen picture shall be displayed. The support of vertical resampling to obtain the correct aspect ratio for a letterbox display of a 16:9 or 2.21:1 coded picture on a 4:3 monitor is optional.

5.1.4 Luminance resolution

Encoding: The encoded picture shall have a full-screen luminance resolution (horizontal × vertical) of one of the following values:

- 720 × 576;
- 544 × 576;
- 480 × 576;
- 352 × 576;
- 352 × 288.

In addition, non full-screen pictures may be encoded for display at less than full-size (when using one of the standard up-conversion ratios at the IRD).

Decoding: The 25 Hz MPEG-2 SDTV IRD shall be capable of decoding pictures with luminance resolutions as shown in Table 5 and applying up sampling to allow the decoded pictures to be displayed at full-screen size. In addition, IRDs shall be capable of decoding lower picture resolutions and displaying them at less than full-size after using one of the standard up-conversions, e.g. a horizontal resolution of 704 pixels within the 720 pixel full-screen display.

Table 5: Resolutions for Full-screen Display from 25 Hz MPEG-2 SDTV IRD

Coded Picture		Displayed Picture Horizontal up sampling	
Luminance resolution (horizontal × vertical)	Aspect Ratio	4:3 Monitors	16:9 Monitors
720 × 576	4:3 16:9 2.21:1	× 1 × 4/3 (see note 2) × 5/3 (see note 3)	× 3/4 (see note 1) × 1 × 5/4 (see note 4)
544 × 576	4:3 16:9 2.21:1	× 4/3 × 16/9 (see note 2) × 20/9 (see note 3)	× 1 (see note 1) × 4/3 × 5/3 (see note 4)
480 × 576	4:3 16:9 2.21:1	× 3/2 × 2 (see note 2) × 5/2 (see note 3)	× 9/8 (see note 1) × 3/2 × 15/8 (see note 4)
352 × 576	4:3 16:9 2.21:1	× 2 × 8/3 (see note 2) × 10/3 (see note 3)	× 3/2 (see note 1) × 2 × 5/2 (see note 4)
352 × 288	4:3 16:9 2.21:1	× 2 × 8/3 (see note 2) × 10/3 (see note 3)	× 3/2 (see note 1) × 2 × 5/2 (see note 4)

(and vertical up sampling × 2) (and vertical up sampling × 2)

NOTE 1: Up sampling of 4:3 pictures for display on a 16:9 monitor is optional in the IRD, as 16:9 monitors can be switched to operate in 4:3 mode.

NOTE 2: The up sampling with this value is applied to the pixels of the 16:9 picture to be displayed on a 4:3 monitor.

NOTE 3: The up sampling with this value is applied to the pixels of the 2.21:1 picture to be displayed on a 4:3 monitor. Up sampling from 2.21:1 pictures for display on a 4:3 monitor is optional in the IRD.

NOTE 4: The up sampling with this value is applied to the pixels of the 2.21:1 picture to be displayed on a 16:9 monitor. Up sampling from 2.21:1 pictures for display on a 16:9 monitor is optional in the IRD.

NOTE 5: It is recommended that luminance resolution of 704 pixels represents the "middle" of the picture, and that it be decoded to a 720 pixel full-screen display by placing 8 pixels of padding at each side. It is recommended that luminance resolutions, such as 352 pixels, that are natural scalings of 704 pixels, be upscaled to 704 pixels and padded as above. It is recommended that all other resolutions be scaled as indicated by the table above. Where this does not result in the expected 720 pixel full-screen display, it is recommended that the result of the scaling be clipped or padded symmetrically as required to produce a 720 pixel full-screen display.

5.1.5 Chromaticity Parameters

Encoding: It is recommended that the chromaticity co-ordinates of the ideal display, opto-electronic transfer characteristic of the ideal display and matrix coefficients used in deriving luminance and chrominance signals from the red, green and blue primaries be explicitly signalled in the encoded bitstream by setting the appropriate values for each of the following 3 parameters in the **sequence_display_extension()**: **colour_primaries**, **transfer_characteristics**, and **matrix_coefficients**.

*Within 25 Hz MPEG-2 SDTV bitstreams, if the **sequence_display_extension()** is not present in the bitstream or **colour_description** is zero, the chromaticity shall be implicitly defined to be that corresponding to **colour_primaries** having the value 5, the transfer characteristics shall be implicitly defined to be those corresponding to **transfer_characteristics** having the value 5 and the matrix coefficients shall be implicitly defined to be those corresponding **matrix_coefficients** having the value 5. This set of parameter values corresponds signals compliance with ITU-R Recommendation BT. 1700 Part B [27].*

NOTE: Previous editions of this document referenced ITU-R Recommendation BT.470 System B, G, I colorimetry (see Bibliography). ITU-R Recommendation BT.1700 [27] replaces ITU-R Recommendation BT. 470.

5.1.6 Chrominance

Encoding: *The operation used to down sample the chrominance information from 4:2:2 to 4:2:0 shall be indicated by the parameter **chroma_420_type** in the picture coding extension. A value of zero indicates that the fields have been down sampled independently. A value of one indicates that the two fields have been combined into a single frame before down sampling. It is desirable that the fields are down sampled independently (i.e. **chroma_420_type** = 0) to allow the IRD to use less memory for picture reconstruction.*

Decoding: *It is desirable that the operation used to up sample the chrominance information from 4:2:0 to 4:2:2 should be dependent on the parameter **chroma_420_type** in the picture coding extension.*

5.1.7 Video sequence header

Encoding: *It is recommended that a video sequence header, immediately followed by an I-frame, be encoded at least once every 500 ms. If quantizer matrices other than the default are used, the appropriate **intra_quantizer_matrix** and/or **non_intra_quantizer_matrix** are recommended to be included in every sequence header.*

NOTE 1: *Increasing the frequency of video sequence headers and I-frames will reduce channel hopping time but will reduce the efficiency of the video compression.*

NOTE 2: *Having a regular interval between I-frames may improve trick mode performance, but may reduce the efficiency of the video compression.*

5.2 25 Hz MPEG-2 HDTV IRDs and Bitstreams

The video encoding shall conform to ITU-T Recommendation H.262 | ISO/IEC 13818-2 [2]. Some of the parameters and fields are not used in the DVB System and these restrictions are described below. The IRD design shall be made under the assumption that any legal structure as permitted by ITU-T Recommendation H.262 | ISO/IEC 13818-2 [2] may occur in the broadcast stream even if presently reserved or unused.

5.2.1 Profile and level

Encoding: *Encoded 25 Hz MPEG-2 HDTV bit-streams shall comply with the Main Profile High Level restrictions, as described ITU-T Recommendation H.262 | ISO/IEC 13818-2 [2], clause 8.2. The **profile_and_level_indication** is "01000100" or, if appropriate, "0nnnnnnn", where "0nnnnnnn">"01000100", indicating a "simpler" profile or level than Main Profile, High Level.*

Decoding: *The 25 Hz MPEG-2 HDTV IRD shall support the decoding of Main Profile High Level bitstreams. This requirement includes support for "simpler" profiles and levels, including Main Profile at Main Level, as defined in table 8-15 of ITU-T Recommendation H.262 | ISO/IEC 13818-2 [2]. Support for profiles and levels beyond Main Profile, High Level is optional. If the IRD encounters an extension which it cannot decode, such as one whose identification code is Reserved, Picture Sequence Scaleable, Picture Spatial Scaleable or Picture Temporal Scaleable, it shall discard the following data until the next start code (to allow backward compatible extensions to be added in the future).*

5.2.2 Frame rate

Encoding: *The frame rate shall be 25 Hz or 50 Hz, i.e. **frame_rate_code** is "0011" or "0110".*

The source video format for 50 Hz frame rate material shall be progressive. The source video format for 25 Hz frame rate material may be interlaced or progressive.

Still pictures may be encoded by use of a video sequence consisting of a single intra-coded picture (see definition of still pictures in ITU-T Recommendation H.222.0 | ISO/IEC 13818-1 [1], clause 2.1.48).

Decoding: *All 25 Hz MPEG-2 HDTV IRDs shall support the decoding and display of video material with a frame rate of 25 Hz progressive, 25 Hz interlaced or 50 Hz progressive (i.e. **frame_rate_code** of "0011" or "0110") within the constraints of Main Profile at High Level. Support of other frame and field rates is optional.*

25 Hz MPEG-2 HDTV IRDs shall be capable of decoding and displaying still pictures, i.e. video sequences consisting of a single intra-coded picture (see definition of still pictures in ITU-T Recommendation H.222.0 | ISO/IEC 13818-1 [1], clause 2.1.48).

5.2.3 Aspect ratio

Encoding: *The source aspect ratio in 25 Hz MPEG-2 HDTV bit-streams shall be 16:9 or 2.21:1. Note that decoding of 2.21:1 aspect ratio is optional for the 25 Hz MPEG-2 HDTV IRD.*

*The **aspect_ratio_information** in the sequence header shall have the value "0011" or "0100".*

Decoding: *The 25 Hz MPEG-2 HDTV IRD shall be able to decode bit-streams with **aspect_ratio_information** of value "0011", corresponding to 16:9 aspect ratio. The support of the aspect ratio 2.21:1 is optional. If the IRD has a digital interface, this should be capable of outputting bit-streams with aspect ratios which are not directly supported by the IRD to allow their decoding and display via an external unit.*

5.2.4 Luminance resolution

Encoding: *The encoded picture shall have a full-screen luminance resolution within the constraints set by Main Profile at High Level, i.e. it shall not have more than:*

- 1 088 lines per frame;
- 1 920 luminance samples per line;
- 62 668 800 luminance samples per second.

It is recommended that the source video for 25 Hz MPEG-2 HDTV Bitstreams has a luminance resolution of:

- 1 080 lines per frame;
- 1 920 luminance samples per line;
- with an associated frame rate of 25 Hz, with two interlaced fields per frame.

The source video may or may not be down-sampled prior to encoding.

The use of other encoded video resolutions within the constraints of Main Profile at High Level is also permitted. annex A of the present document provides examples of supported full-screen luminance resolutions. In addition, non full-screen pictures may be encoded for display at less than full-size.

NOTE 1: The limit of 62 668 800 luminance samples per second of Main Profile at High Level excludes the use of the maximum allowed picture resolution at 50 Hz frame rate.

NOTE 2: If the recommended source video format is encoded without down-sampling it gives 51 840 000 luminance samples per second and therefore falls within the allowed range for Main Profile at High Level.

Decoding: *The 25 Hz MPEG-2 HDTV IRD shall be capable of decoding and displaying pictures with luminance resolutions within the constraints set by Main Profile at High Level.*

5.2.5 Chromaticity Parameters

Encoding: *The chromaticity co-ordinates of the ideal display, opto-electronic transfer characteristic of the source picture and matrix coefficients used in deriving luminance and chrominance signals from the red, green and blue primaries shall be explicitly signalled in the encoded HDTV bitstream by setting the appropriate values for each of the following 3 parameters in the `sequence_display_extension()`: **colour_primaries**, **transfer_characteristics**, and **matrix_coefficients**.*

It is recommended that ITU-R Recommendation BT.709 [13] colorimetry is used in the 25 Hz HDTV bitstream, which is signalled by setting **colour_primaries** to the value 1, **transfer_characteristics** to the value 1 and **matrix_coefficients** to the value 1.

Decoding: *The 25 Hz MPEG-2 HDTV IRD shall be capable of decoding bitstreams with any allowed values of **colour_primaries**, **transfer_characteristics** and **matrix_coefficients**. It is recommended that appropriate processing be included for the accurate representation of pictures using ITU-R Recommendation BT.709 [13] colorimetry.*

NOTE: For the 50 Hz 576P video format the colorimetry standard recommended is ITU-R Recommendation BT.1358.

5.2.6 Chrominance

Encoding: The operation used to down sample the chrominance information from 4:2:2 to 4:2:0 shall be indicated by the parameter **chroma_420_type** in the picture coding extension. A value of zero indicates that the fields have been down sampled independently. A value of one indicates that the two fields have been combined into a single frame before down sampling. It is desirable that the fields are down sampled independently (i.e. **chroma_420_type** = 0) to allow the IRD to use less memory for picture reconstruction.

Decoding: It is desirable that the operation used to up sample the chrominance information from 4:2:0 to 4:2:2 should be dependent on the parameter **chroma_420_type** in the picture coding extension.

5.2.7 Video sequence header

Encoding: It is recommended that a video sequence header, immediately followed by an I-frame, be encoded at least once every 500 ms. If quantizer matrices other than the default are used, the appropriate **intra_quantizer_matrix** and/or **non_intra_quantizer_matrix** are recommended to be included in every sequence header.

NOTE 1: Increasing the frequency of video sequence headers and I-frames will reduce channel hopping time but will reduce the efficiency of the video compression.

NOTE 2: Having a regular interval between I-frames may improve trick mode performance, but may reduce the efficiency of the video compression.

5.2.8 Backwards Compatibility

Decoding: *In addition to the above, a 25 Hz MPEG-2 HDTV IRD shall be capable of decoding any bitstream that a 25 Hz MPEG-2 SDTV IRD is required to decode, as described in clause 5.1.*

5.3 30 Hz MPEG-2 SDTV IRDs and Bitstreams

The video encoding shall conform to ITU-T Recommendation H.262 | ISO/IEC 13818-2 [2]. Some of the parameters and fields are not used in the DVB System and these restrictions are described below. The IRD design shall be made under the assumption that any legal structure as permitted by ITU-T Recommendation H.262 | ISO/IEC 13818-2 [2] may occur in the broadcast stream even if presently reserved or unused.

5.3.1 Profile and level

Encoding: *Encoded bit-streams shall comply with the Main Profile Main Level restrictions, as described ITU-T Recommendation H.262 | ISO/IEC 13818-2 [2], clause 8.2. The **profile_and_level_indication** is "01001000" or, if appropriate, "Onnnnnnn", where "Onnnnnnn">"01001000", indicating a "simpler" profile or level than Main Profile, Main Level.*

Decoding: *The IRD shall support the syntax of Main Profile. Support for profiles and levels beyond Main Profile, Main Level is optional. If the IRD encounters an extension which it cannot decode, such as one whose identification code is Reserved, Picture Sequence Scaleable, Picture Spatial Scaleable or Picture Temporal Scaleable, it shall discard the following data until the next start code (to allow backward compatible extensions to be added in the future).*

5.3.2 Frame rate

Encoding: *The frame rate shall be either 24 000/1 001, 24, 30 000/1 001 or 30 Hz, i.e. the **frame_rate_code** field shall be encoded with one of the following values: "0001", "0010", "0100" or "0101".*

Still pictures may be encoded by use of a video sequence consisting of a single intra-coded picture (see definition of still pictures in ITU-T Recommendation H.222.0 | ISO/IEC 13818-1 [1], clause 2.1.48).

Decoding: *All 30 Hz SDTV IRDs shall support the decoding and display of Main Profile @ Main Level video with a frame rate of 24 000/1001, 24, 30 000/1 001 or 30 Hz. Support of other frame rates is optional.*

IRDs shall be capable of decoding and displaying still pictures, i.e. video sequences consisting of a single intra-coded picture (see definition of still pictures in ITU-T Recommendation H.222.0 | ISO/IEC 13818-1 [1], clause 2.1.48).

5.3.3 Aspect ratio

Encoding: *The source aspect ratio in 30 Hz MPEG-2 SDTV bit-streams shall be either 4:3, 16:9 or 2.21:1. Note that decoding of 2.21:1 aspect ratio is optional for the 30 Hz SDTV IRD.*

*The **aspect_ratio_information** in the sequence header shall have one of the following three values:*

- 4:3 aspect ratio source: "0010";
- 16:9 aspect ratio source: "0011";
- 2.21:1 aspect ratio source: "0100".

It is recommended that pan vectors for a 4:3 window are included in the transmitted bit-stream when the source aspect ratio is 16:9 or 2.21:1. The vertical component of the transmitted pan vector shall be zero.

*If pan vectors are transmitted then the **sequence_display_extension** shall be present in the bit-stream and the **aspect_ratio_information** shall be set to '0010' (4:3 display). The **display_vertical_size** shall be equal to the **vertical_size**. The **display_horizontal_size** shall contain the resolution of the target 4:3 display. The value of the **display_horizontal_size** field may be calculated by the following equation:*

$$\text{display_horizontal_size} = \frac{4}{3} \times \frac{\text{horizontal_size}}{\text{source aspect ratio}}$$

Table 6 gives some typical examples:

Table 6: Values for display_horizontal_size

horizontal_size × vertical_size	Source aspect ratio	display_horizontal_size
720 × 480	16:9	540
640 × 480	16:9	480
544 × 480	16:9	408
480 × 480	16:9	360
352 × 480	16:9	264
352 × 240	16:9	264

Decoding: *The 30 Hz MPEG-2 SDTV IRD shall be able to decode bit-streams with values of aspect_ratio_information of "0010" and "0011", corresponding to 4:3 and 16:9 aspect ratio respectively. If the IRD has a digital interface, this should be capable of outputting bit-streams with aspect ratios which are not directly supported by the IRD to allow their decoding and display via an external unit.*

All 30 Hz MPEG-2 SDTV IRDs shall support the use of pan vectors and up sampling to allow a 4:3 monitor to give a full-screen display of a selected portion of a 16:9 coded picture with the correct aspect ratio. IRDs implementing the 2.21:1 aspect ratio should support the use of pan vectors and up sampling to allow a 4:3 monitor to give a full-screen display of a selected portion of the 2.21:1 picture with the correct aspect ratio. Support for pan vectors with non-zero vertical components is optional. When no pan vectors are present in the transmitted bit-stream, the central portion of the wide-screen picture shall be displayed. The support of vertical resampling to obtain the correct aspect ratio for a letterbox display of a 16:9 or 2.21:1 coded picture on a 4:3 monitor is optional.

5.3.4 Luminance resolution

Encoding: The encoded picture shall have a full-screen luminance resolution (horizontal × vertical) of one of the following values:

- 720 × 480;
- 640 × 480;
- 544 × 480;
- 480 × 480;
- 352 × 480;
- 352 × 240.

In addition, non full-screen pictures may be encoded for display at less than full-size (when using one of the standard up-conversion ratios at the IRD).

Decoding: *The 30 Hz MPEG-2 SDTV IRD shall be capable of decoding pictures with luminance resolutions as shown in Table 7 and applying up sampling to allow the decoded pictures to be displayed at full-screen size. In addition, IRDs shall be capable of decoding lower picture resolutions and displaying them at less than full-size after using one of the standard up-conversions, e.g. a horizontal resolution of 704 pixels within the 720 pixel full-screen display.*

Table 7: Resolutions for Full-screen Display from 30 Hz MPEG-2 SDTV IRD

Coded Picture		Displayed Picture Horizontal up sampling	
Luminance resolution (horizontal × vertical)	Aspect Ratio	4:3 Monitors	16:9 Monitors
720 × 480	4:3 16:9 2:21:1	× 1 × 4/3 (see note 2) × 5/3 (see note 3)	× 3/4 (see note 1) × 1 × 5/4 (see note 4)
640 × 480	4:3	× 9/8	× 27/32 (see note 1)
544 × 480	4:3 16:9 2:21:1	× 4/3 × 16/9 (see note 2) × 20/9 (see note 3)	× 1 (see note 1) × 4/3 × 5/3 (see note 4)
480 × 480	4:3 16:9 2:21:1	× 3/2 × 2 (see note 2) × 5/2 (see note 3)	× 9/8 (see note 1) × 3/2 × 15/8 (see note 4)
352 × 480	4:3 16:9 2:21:1	× 2 × 8/3 (see note 2) × 10/3 (see note 3)	× 3/2 (see note 1) × 2 × 5/2 (see note 4)
352 × 240	4:3 16:9 2:21:1	× 2 × 8/3 (see note 2) × 10/3 (see note 3)	× 3/2 (see note 1) × 2 × 5/2 (see note 4)
		(and vertical up sampling × 2)	(and vertical up sampling × 2)

NOTE 1: Up sampling of 4:3 pictures for display on a 16:9 monitor is optional in the IRD, as 16:9 monitors can be switched to operate in 4:3 mode.

NOTE 2: The up sampling with this value is applied to the pixels of the 16:9 picture to be displayed on a 4:3 monitor.

NOTE 3: The up sampling with this value is applied to the pixels of the 2.21:1 picture to be displayed on a 4:3 monitor. Up sampling from 2.21:1 pictures for display on a 4:3 monitor is optional in the IRD.

NOTE 4: The up sampling with this value is applied to the pixels of the 2.21:1 picture to be displayed on a 16:9 monitor. Up sampling from 2.21:1 pictures for display on a 16:9 monitor is optional in the IRD.

NOTE 5: It is recommended that luminance resolution of 704 pixels represents the "middle" of the picture, and that it be decoded to a 720 pixel full-screen display by placing 8 pixels of padding at each side. It is recommended that luminance resolutions, such as 352 pixels, that are natural scalings of 704 pixels, be upscaled to 704 pixels and padded as above. It is recommended that all other resolutions be scaled as indicated by the table above. Where this does not result in the expected 720 pixel full-screen display, it is recommended that the result of the scaling be clipped or padded symmetrically as required to produce a 720 pixel full-screen display.

5.3.5 Chromaticity Parameters

Encoding: It is recommended that the chromaticity co-ordinates of the ideal display, opto-electronic transfer characteristic of the ideal display and matrix coefficients used in deriving luminance and chrominance signals from the red, green and blue primaries be explicitly signalled in the encoded bitstream by setting the appropriate values for each of the following 3 parameters in the **sequence_display_extension()**: **colour_primaries**, **transfer_characteristics**, and **matrix_coefficients**.

*Within 30 Hz SDTV bitstreams, if the **sequence_display_extension()** is not present in the bitstream or **colour_description** is zero, the chromaticity shall be implicitly defined to be that corresponding to **colour_primaries** having the value 6, the transfer characteristics shall be implicitly defined to be those corresponding to **transfer_characteristics** having the value 6 and the matrix coefficients shall be implicitly defined to be those corresponding **matrix_coefficients** having the value 6. This set of parameter values signals compliance with ITU-R Recommendation BT.1700 Part A [27].*

NOTE: Previous editions of this document referenced SMPTE 170M colorimetry (see Bibliography). ITU-R Recommendation BT.1700 Part A [27] references SMPTE 170M.

5.3.6 Chrominance

Encoding: *The operation used to down sample the chrominance information from 4:2:2 to 4:2:0 shall be indicated by the parameter **chroma_420_type** in the picture coding extension. A value of zero indicates that the fields have been down sampled independently. A value of one indicates that the two fields have been combined into a single frame before down sampling. It is desirable that the fields are down sampled independently (i.e. **chroma_420_type** = 0) to allow the IRD to use less memory for picture reconstruction.*

Decoding: *It is desirable that the operation used to up sample the chrominance information from 4:2:0 to 4:2:2 should be dependent on the parameter **chroma_420_type** in the picture coding extension.*

5.3.7 Video sequence header

Encoding: *It is recommended that a video sequence header, immediately followed by an I-frame, be encoded at least once every 500 ms. If quantizer matrices other than the default are used, the appropriate **intra_quantizer_matrix** and/or **non_intra_quantizer_matrix** are recommended to be included in every sequence header.*

NOTE 1: *Increasing the frequency of video sequence headers and I-frames will reduce channel hopping time but will reduce the efficiency of the video compression.*

NOTE 2: *Having a regular interval between I-frames may improve trick mode performance, but may reduce the efficiency of the video compression.*

5.4 30 Hz MPEG-2 HDTV IRDs and Bitstreams

The video encoding shall conform to ITU-T Recommendation H.262 | ISO/IEC 13818-2 [2]. Some of the parameters and fields are not used in the DVB System and these restrictions are described below. The IRD design shall be made under the assumption that any legal structure as permitted by ITU-T Recommendation H.262 | ISO/IEC 13818-2 [2] may occur in the broadcast stream even if presently reserved or unused.

5.4.1 Profile and level

Encoding: *Encoded 30 Hz MPEG-2 HDTV bit-streams shall comply with the Main Profile High Level restrictions, as described ITU-T Recommendation H.262 | ISO/IEC 13818-2 [2], clause 8.2.*

*The **profile_and_level_indication** is "01000100" or, if appropriate, "Onnnnnnn", where "Onnnnnnn">"01000100", indicating a "simpler" profile or level than Main Profile, High Level.*

Decoding: *The 30 Hz MPEG-2 HDTV IRD shall support the decoding of Main Profile High Level bitstreams. This requirement includes support for "simpler" profiles and levels, including Main Profile at Main Level, as defined in table 8-15 of ITU-T Recommendation H.262 | ISO/IEC 13818-2 [2]. Support for profiles and levels beyond Main Profile, High Level is optional. If the IRD encounters an extension which it cannot decode, such as one whose identification code is Reserved, Picture Sequence Scaleable, Picture Spatial Scaleable or Picture Temporal Scaleable, it shall discard the following data until the next start code (to allow backward compatible extensions to be added in the future).*

5.4.2 Frame rate

Encoding: *The frame rate shall be 24 000/1 001, 24, 30 000/1 001, 30, 60 000/1 001 or 60 Hz, i.e. **frame_rate_code** is "0001", "0010", "0100", "0101", "0111" or "1000".*

The source video format for 24 000/1 001, 24, 60 000/1 001 and 60 Hz frame rate material shall be progressive. The source video format for 30 000/1 001 and 30 Hz frame rate material may be interlaced or progressive.

Still pictures may be encoded by use of a video sequence consisting of a single intra-coded picture (see definition of still pictures in ITU-T Recommendation H.222.0 | ISO/IEC 13818-1 [1], clause 2.1.48).

Decoding: *All 30 Hz MPEG-2 HDTV IRDs shall support the decoding of video material with a frame rate of 24 000/1 001, 24, 30 000/1 001, 30, 60 000/1 001 or 60 Hz (i.e. **frame_rate_code** of "0001", "0010", "0100", "0101", "0111" or "1000") within the constraints of Main Profile at High Level. Support of other frame rates is optional.*

30 Hz MPEG-2 HDTV IRDs shall support the display of video whose source frame rate is 24 000/1 001, 24, 30 000/1 001, 30, 60 000/1001 or 60 Hz progressive. 30 Hz MPEG-2 HDTV IRDs shall support the display of video whose source frame rate is 30000/1001 or 30 Hz interlaced.

30 Hz MPEG-2 HDTV IRDs shall be capable of decoding and displaying still pictures, i.e. video sequences consisting of a single intra-coded picture (see definition of still pictures in ITU-T Recommendation H.222.0 | ISO/IEC 13818-1 [1], clause 2.1.48).

5.4.3 Aspect ratio

Encoding: *The source aspect ratio in 30 Hz MPEG-2 HDTV bit-streams shall be 16:9 or 2.21:1. Note that decoding of 2.21:1 aspect ratio is optional for the 30 Hz MPEG-2 HDTV IRD.*

*The **aspect_ratio_information** field in the sequence header shall have the value "0011" or "0100".*

Decoding: *The 30 Hz MPEG-2 HDTV IRD shall be able to decode bit-streams with **aspect_ratio_information** of value "0011", corresponding to 16:9 aspect ratio. If the IRD has a digital interface, this should be capable of outputting bit-streams with aspect ratios which are not directly supported by the IRD to allow their decoding and display via an external unit.*

5.4.4 Luminance resolution

Encoding: *The encoded picture shall have a full-screen luminance resolution within the constraints set by Main Profile at High Level, i.e. it shall not have more than:*

- 1 088 lines per frame;
- 1 920 luminance samples per line;
- 62 668 800 luminance samples per second.

It is recommended that the source video for 30 Hz MPEG-2 HDTV Bitstreams has a luminance resolution of:

- 1 080 lines per frame and 1 920 luminance samples per line, with an associated frame rate of 30 000/1 001 (approximately 29.97) Hz with two interlaced fields per frame.
- The source video may or may not be down-sampled prior to encoding.
- The use of other encoded video resolutions within the constraints of Main Profile at High Level is also permitted. annex A of the present document provides examples of supported full-screen luminance resolutions. In addition, non full-screen pictures may be encoded for display at less than full-size.
- The limit of 62 668 800 luminance samples per second of Main Profile at High Level excludes the use of the maximum allowed picture resolution at 60 Hz and 60 000/1001 frame rates.

NOTE: If the recommended source video format is encoded without down-sampling it gives 62 145 854 luminance sample per second and therefore falls within the allowed range for Main Profile at High Level.

Decoding: *The 30 Hz MPEG-2 HDTV IRD shall be capable of decoding and displaying pictures with luminance resolutions within the constraints set by Main Profile at High Level.*

5.4.5 Chromaticity Parameters

Encoding: *The chromaticity co-ordinates of the ideal display, opto-electronic transfer characteristic of the source picture and matrix coefficients used in deriving luminance and chrominance signals from the red, green and blue primaries shall be explicitly signalled in the encoded HDTV bitstream by setting the appropriate values for each of the following 3 parameters in the `sequence_display_extension()`: **colour_primaries**, **transfer_characteristics**, and **matrix_coefficients**.*

It is recommended that ITU-R Recommendation BT.709 [13] colorimetry is used in the 30 Hz HDTV bitstream, which is signalled by setting **colour_primaries** to the value 1, **transfer_characteristics** to the value 1 and **matrix_coefficients** to the value 1.

Decoding: *The 30 Hz HDTV IRD shall be capable of decoding bitstreams with any allowed values of **colour_primaries**, **transfer_characteristics** and **matrix_coefficients**. It is recommended that appropriate processing be included for the accurate representation of pictures using ITU-R Recommendation BT.709 [13] colorimetry*

NOTE: For the 60 000/1 001 or 60 Hz 480P video format the colorimetry standard recommended is ITU-R Recommendation BT.1358.

5.4.6 Chrominance

Encoding: *The operation used to down sample the chrominance information from 4:2:2 to 4:2:0 shall be indicated by the parameter **chroma_420_type** in the picture coding extension. A value of zero indicates that the fields have been down sampled independently. A value of one indicates that the two fields have been combined into a single frame before down sampling. It is desirable that the fields are down sampled independently (i.e. **chroma_420_type** = 0) to allow the IRD to use less memory for picture reconstruction.*

Decoding: It is desirable that the operation used to up sample the chrominance information from 4:2:0 to 4:2:2 should be dependent on the parameter **chroma_420_type** in the picture coding extension.

5.4.7 Video sequence header

Encoding: It is recommended that a video sequence header, immediately followed by an I-frame, be encoded at least once every 500 ms. If quantizer matrices other than the default are used, the appropriate **intra_quantizer_matrix** and/or **non_intra_quantizer_matrix** are recommended to be included in every sequence header.

NOTE 1: Increasing the frequency of video sequence headers and I-frames will reduce channel hopping time but will reduce the efficiency of the video compression.

NOTE 2: Having a regular interval between I-frames may improve trick mode performance, but may reduce the efficiency of the video compression.

5.4.8 Backwards Compatibility

Decoding: *In addition to the above, a 30 Hz MPEG-2 HDTV IRD shall be capable of decoding any bitstream that a 30 Hz MPEG-2 SDTV IRD is required to decode, as described in clause 5.3.*

5.5 Specifications Common to all H.264/AVC IRDs and Bitstreams

The specification in this clause applies to the following IRDs and Bitstreams:

- 25 Hz H.264/AVC SDTV IRD and Bitstream;
- 30 Hz H.264/AVC SDTV IRD and Bitstream;
- 25 Hz H.264/AVC HDTV IRD and Bitstream;
- 30 Hz H.264/AVC HDTV IRD and Bitstream.

5.5.1 General

The video encoding and video decoding shall conform to ITU-T Recommendation H.264 | ISO/IEC 14496-10 [16]. Some of the parameters and fields are not used in the DVB System and these restrictions are described below. H.264/AVC Bitstreams and IRDs shall support some parts of the "Supplemental enhancement information (SEI)" and the "Video usability information (VUI)" syntax elements as specified in ITU-T Recommendation H.264 | ISO/IEC 14496-10 annexes D and E [16]. The H.264/AVC IRD design shall be made under the assumption that any legal structure as permitted by ITU-T Recommendation H.264 | ISO/IEC 14496-10 [16] and the restrictions that are specified for the H.264/AVC IRDs may occur in the broadcast stream even if presently reserved or unused.

NOTE: To improve trick mode it is strongly recommended to disable non-paired fields in H.264/AVC Encoder.

5.5.2 Sequence Parameter Set and Picture Parameter Set

Encoding: More than one picture parameter set can be present in the bitstream between two H.264/AVC RAPs. *Between two H.264/AVC RAPs, the content of a picture parameter set with a particular **pic_parameter_set_id** shall not change.* I.e. if more than one picture parameter set is present in the bitstream and these picture parameter sets are different from each other, then each picture parameter set shall have a different **pic_parameter_set_id**.

NOTE: Multiple PPSs may be present in the H.264/AVC RAP access unit and the number of PPS that may be present is constrained by 4.1.5.2 where the start of the access unit (**access_unit_delimiter**) and the start of the first slice of the access unit must occur either in the same transport packet or in 2 successive transport packets.

5.5.2.1 **pic_width_in_mbs_minus1** and **pic_height_in_map_units_minus1**

Encoding: *The time interval between two changes in pairs of **pic_width_in_mbs_minus1** and **pic_height_in_map_units_minus1** shall be greater than or equal to one second.* Changing the pair **pic_width_in_mbs_minus1** and **pic_height_in_map_units_minus1** requires software processing in the decoder. Limiting the frequency of this change is to constrain the IRD software processing required to support aspect ratio changes.

NOTE: A pair of **pic_width_in_mbs_minus1** and **pic_height_in_map_units_minus1** is distinct from another pair if one or both syntax element values **pic_width_in_mbs_minus1** and **pic_height_in_map_units_minus1** differ.

If the number of samples per row of the luminance component of the source picture is not an integer multiple of 16 and additional samples are padded to make the number of samples per row of the luminance component an integer multiple of 16, it is recommended that these samples are padded at the right side of the picture.

If the number of samples per column of the luminance component of the source picture is not an integer multiple of 16 and additional samples are padded to make the number of samples per column of the luminance component an integer multiple of 16, it is recommended that these samples are padded at the bottom of the picture.

5.5.3 Video Usability Information

The IRD shall support the use of Video Usability Information of the following syntax elements:

- Aspect Ratio Information (*aspect_ratio_idc*);
- Colour Parameter Information (*colour_primaries*, *transfer_characteristics*, and *matrix_coefficients*);
- Chrominance Information (*chroma_sample_loc_type_top_field* and *chroma_sample_loc_type_bottom_field*);
- Timing information (*time_scale*, *num_units_in_tick*, and *fixed_frame_rate_flag*).
- Picture Structure Information (*pic_struct_present_flag*)

5.5.3.1 Aspect Ratio Information

The support of **aspect_ratio_idc** values for H.264/AVC SDTV IRDs and Bitstreams is specified in clause 5.6.1.3 and for H.264/AVC HDTV IRDs and Bitstreams is specified in clause 5.7.1.3.

5.5.3.2 Colour Parameter Information

The support of **colour_primaries**, **transfer_characteristics**, and **matrix_coefficients** values for the 25 Hz H.264/AVC SDTV IRD and Bitstream is specified in clause 5.6.2.1, for the 30 Hz H.264/AVC SDTV IRD and Bitstream is specified in clause 5.6.3.1, and for H.264/AVC HDTV IRDs and Bitstreams is specified in clause 5.7.1.3.

5.5.3.3 Chrominance Information

- Encoding: It is recommended to specify the chrominance locations using the syntax elements **chroma_sample_loc_type_top_field** and **chroma_sample_loc_type_bottom_field** in the VUI. It is recommended to use chroma sample type equal to 0 for both fields.
- Decoding: *H.264/AVC IRDs shall support decoding any allowed values of **chroma_sample_loc_type_top_field** and **chroma_sample_loc_type_bottom_field**. It is recommended that appropriate processing be included for the display of pictures.*

5.5.3.4 Timing Information

The support of **time_scale** and **num_units_in_tick** values for the 25 Hz H.264/AVC SDTV IRD and Bitstream is specified in clause 5.6.2.2, for the 30 Hz H.264/AVC SDTV IRD and Bitstream is specified in clause 5.6.3.2, for the 25 Hz H.264/AVC HDTV IRD and Bitstream is specified in clause 5.7.2.1, for the 30 Hz H.264/AVC HDTV IRD and Bitstream is specified in clause 5.7.3.1. *In the case of still picture the **fixed_frame_rate_flag** shall be equal to 0. In other cases, the **fixed_frame_rate_flag** shall be equal to 1.* The frame rate can not be changed between two IDR access units.

5.5.3.5 Picture Structure Information

The support of **pic_struct_present_flag** and Bitstream is specified in clause 5.5.4.1 related to use of Picture Structure information in the Picture Timing SEI and is common to all H.264/AVC IRDs and Bitstreams. For bitstreams that carry the picture structure information (such as film mode), it is recommended that the **pic_struct_present_flag** be set to "1" in the VUI and the picture timing SEI is associated with each access unit in the coded sequence. If the sequence does not require picture structure information, then the **pic_struct_present_flag** should be set to "0" in the VUI. Use of this flag bit in the VUI allows use of picture timing SEI with only the picture structure information without the need to include HRD information (such as CPB and DPB delay or initial values of the delay in the buffering period SEI).

5.5.4 Supplemental Enhancement Information

The IRD shall support the use of Supplemental Enhancement Information of the following message types:

- Picture Timing SEI Message;
- Pan and Scan Rectangle SEI Message;
- "User data registered by ITU-T Recommendation T.35 SEI message" syntactic element [20] **user_data_registered_itu_t_t35** as defined in B.7.

5.5.4.1 Picture Timing SEI Message

Encoding: *If the H.264/AVC bit stream contains picture structure information, then the **pic_struct_present_flag** shall be set to "1" in the VUI and the Picture Timing SEI message shall be associated with every access unit. Otherwise the **pic_struct_present_flag** shall be set to "0".*

Decoding: *H.264/AVC IRDs shall support all values defined in **pic_struct** including all modes requiring field and frame repetition. The H.264/AVC IRDs need not make use of any other syntax elements (except **pic_struct**) in the Picture Timing SEI message, if these elements are present.*

NOTE: If present, the picture structure information shall convey the picture output order in the same order as the Picture Order Count (POC) information in the H.264/AVC bitstream (per Subclause D.2.2 of ITU-T Rec. H.264 | ISO/IEC 14496-10 [16]). This ensures consistency between the SEI message and the HRD model of ITU-T Rec. H.264 | ISO/IEC 14496-10 [16].

5.5.4.2 Pan-Scan Rectangle SEI Message

Encoding: The **pan_scan_rect** SEI may be used when appropriate.

Decoding: *H.264/AVC IRDs shall support all values specified in **pan_scan_rect**, except **pan_scan_rect_top_offset[i]** and **pan_scan_rect_bottom_offset[i]**. The IRD need not make use of **pan_scan_rect_top_offset[i]** and **pan_scan_rect_bottom_offset[i]** parameters in the **pan_scan_rect** SEI message.*

The support of the use of **pan_scan_rect** for up sampling is specified to allow a 4:3 monitor to give a full-screen display of a selected portion of a 16:9 coded picture with the correct aspect ratio. The support of vertical resampling to obtain the correct aspect ratio for a letterbox display of a 16:9 coded picture on a 4:3 monitor is optional.

NOTE: Use of AFD as defined in B.3 and Bar Data as defined in B.4 may provide a more convenient mechanism for enabling the full screen display of a selected portion of the coded picture.

5.5.4.3 Still pictures

Encoding: *Still pictures shall comply with "AVC still picture" definition as per ITU-T Recommendation H.222.0 | ISO/IEC 13818-1 / Amd-3 [1]. For Still pictures the frame rate specification for H264 AVC IRDs shall not apply. The **fixed_frame_rate_flag** shall be equal to 0.*

NOTE: For display that requires a fixed frame refresh according to the IRD frequency, the previously decoded picture should be displayed till the next picture is available.

5.5.5 Random Access Point

The definition for H.264/AVC RAP in clause 3 shall apply.

Encoding: The time interval between H.264/AVC RAPs may vary between programs and also within a program. The broadcast requirements should set the time interval between H.264/AVC RAPs as specified in clause 5.5.5.1 below.

NOTE: The AU_information_descriptor described in Annex D provides a means of signalling information about Random Access Points that may be used by some applications, and it is recommended that this is present.

All pictures with PTS greater than or equal to PTS(rap) shall be fully reconstructable and displayable, where PTS(rap) represents the Presentation Time Stamp of the picture of the H.264/AVC RAP. This means that decoders receiving the RAP shall not need to utilise data transmitted prior to the RAP to decode pictures displayed after the RAP..

To improve applications such as channel change, it is recommended that the Presentation Time Stamp of the picture of H.264/AVC RAP be less than or equal to $[DTS(rap) + 0.5 \text{ seconds}]$ where DTS(rap) represents the Decoding Time Stamp of the picture of H.264/AVC RAP.

Packetization of random access points shall comply with the following additional rule:

*A transport packet containing the PES header of a H.264/AVC RAP shall have an adaptation field. The **payload_unit_start_indicator** bit shall be set to "1" in the transport packet header and the **adaptation_field_control** bits shall be set to "11" (as per ITU-T Recommendation H.222.0 | ISO/IEC 13818-1 [1]). In addition, the **random_access_indicator** bit in the adaptation header shall be set to "1". The **elementary_stream_priority_indicator** bit shall also be set to "1" in the same adaptation header if this transport packet contains the slice start code of the H.264/AVC RAP access unit (see clauses 4.1.5.1 and 4.1.5.2).*

Decoding: *H.264/AVC IRDs shall be able to start decoding and displaying an H.264/AVC Bitstream at an H.264/AVC RAP.*

5.5.5.1 Time Interval Between RAPs

Encoding: The encoder shall place H.264/AVC RAPs in the video elementary stream at least once every 5 s. It is recommended that H.264/AVC RAPs occur in the video elementary stream on average at least every 2 s. Where rapid channel change times are important or for applications such as PVR it may be appropriate for H.264/AVC RAPs to occur more frequently, such as every 500 ms. The time interval between successive RAPs shall be measured as the difference between their respective DTS values.

NOTE 1: Decreasing the time interval between H.264/AVC RAPs may reduce channel hopping time and improve trick modes, but may reduce the efficiency of the video compression.

NOTE 2: Having a regular interval between H.264/AVC RAPs may improve trick mode performance, but may reduce the efficiency of the video compression.

5.6 H.264/AVC SDTV IRDs and Bitstreams

5.6.1 Specifications Common to all H.264/AVC SDTV IRDs and Bitstreams

The specification in this clause applies to the following IRDs and bitstreams:

- 25 Hz H.264/AVC SDTV IRD and Bitstream;
- 30 Hz H.264/AVC SDTV IRD and Bitstream.

5.6.1.1 Sequence Parameter Set and Picture Parameter Set

Encoding: *In addition to the provisions set forth in ITU-T Recommendation H.264 | ISO/IEC 14496-10 [16], the following restrictions apply for the fields in the sequence parameter set:*

profile_idc = 77 (Main Profile)

profile_idc	= 100 when bitstream complies with High Profile. See clause 5.6.1.2 for details of when the bitstream may optionally comply with High Profile
constraint_set0_flag	= 0
constraint_set1_flag	= 1 (when profile_idc = 77) or = 0 (when profile_idc = 100)
constraint_set2_flag	= 0
constraint_set3_flag	= 0 (when profile_idc = 100)
gaps_in_frame_num_value_allowed_flag	= 0 (gaps not allowed)
vui_parameters_present_flag	= 1

5.6.1.2 Profile and level

Encoding: *H.264/AVC SDTV Bitstreams shall comply with Main Profile Level 3 restrictions, as described in ITU-T Recommendation H.264 | ISO/IEC 14496-10 [16]. In addition, in applications where decoders support the High Profile, the encoded bitstream may optionally comply with the High Profile.*

The value of level_idc shall be equal to 30.

Decoding: *H.264/AVC SDTV IRDs shall support decoding and displaying of Main Profile Level 3 bitstreams. Support of the High Profile and other profiles beyond Main Profile is optional. Support of levels beyond Level 3 is optional. If the H.264/AVC SDTV IRD encounters an extension which it cannot decode, it shall discard the following data until the next start code prefix (to allow backward compatible extensions to be added in the future).*

5.6.1.3 Aspect ratio

Encoding: *The source aspect ratio in H.264/AVC SDTV Bitstreams shall be either 4:3 or 16:9.*

The frame cropping information in the Sequence Parameter Set may be used when appropriate.

Decoding: *H.264/AVC SDTV IRDs shall support decoding and displaying H.264/AVC SDTV Bitstreams with the values of aspect_ratio_idc and other constraints that are specified in clause 5.6.2 for the 25 Hz H.264/AVC SDTV IRDs and Bitstreams and clause 5.6.3 for the 30 Hz H.264/AVC SDTV IRDs and Bitstreams.*

*The source aspect ratio information shall be derived from the **pic_height_in_map_units_minus1** and the **pic_width_in_mbs_minus1** and the frame cropping information coded in the Sequence Parameter Set as well as the sample aspect ratio encoded with the **aspect_ratio_idc** value in the Video Usability Information (see values of **aspect_ratio_idc** in ITU-T Recommendation H.264 | ISO/IEC 14496-10 [16], table E-1).*

H.264/AVC SDTV IRDs shall support frame cropping.

5.6.2 25 Hz H.264/AVC SDTV IRD and Bitstream

This clause specifies the 25 Hz H.264/AVC SDTV IRD and Bitstream. All specifications in clauses 5.5 and 5.6.1 shall apply. The specification in the remainder of this clause only applies to the 25 Hz H.264/AVC SDTV IRD and Bitstream.

5.6.2.1 Colour Parameter Information

Encoding: *The chromaticity co-ordinates of the ideal display, opto-electronic transfer characteristic of the source picture and matrix coefficients used in deriving luminance and chrominance signals from the red, green and blue primaries shall be explicitly signalled in the encoded 25 Hz H.264/AVC SDTV Bitstream by setting the appropriate values for each of the following 3 parameters in the VUI: **colour_primaries**, **transfer_characteristics**, and **matrix_coefficients**.*

It is recommended that ITU-R Recommendation BT.1700 Part B [27] colorimetry is used in the H.264/AVC bitstream, which is signalled by setting **colour primaries** to the value 5, **transfer characteristics** to the value 5 and **matrix coefficients** to the value 5.

Decoding: *25 Hz H.264/AVC SDTV IRDs shall support decoding bitstreams with any allowed values of **colour primaries**, **transfer characteristics** and **matrix coefficients**. It is recommended that appropriate processing be included for the accurate representation of pictures using BT. ITU-R Recommendation BT.1700 Part B [27] colorimetry.*

NOTE: Previous editions of this document referenced ITU-R Recommendation BT.470 System B, G colorimetry (see Bibliography). ITU-R Recommendation BT.1700 [27] replaces ITU-R Recommendation BT. 470.

5.6.2.2 Frame rate

Encoding: The frame rate shall be 25 Hz in 25 Hz H.264/AVC Bitstreams. This shall be indicated in the VUI by setting **time_scale** and **num_units_in_tick** according to Table 8. **time_scale** and **num_units_in_tick** define the picture rate of the video.

Table 8: time_scale and num_units_in_tick for Progressive and Interlace Frame Rates for 25 Hz H.264/AVC SDTV

Frame Rate	Interlaced or Progressive	time_scale	Num_units_in_tick
25	P	50	1
25	I	50	1

Decoding: *25 Hz H.264/AVC SDTV IRDs shall support decoding and displaying video with a frame rate of 25 Hz within the constraints of Main Profile at Level 3. Support of other frame rates is optional.*

5.6.2.3 Luminance resolution

Encoding: *25 Hz H.264/AVC SDTV Bitstreams shall represent video with luminance resolutions as shown in Table 9. Non full-screen pictures may be encoded for display at less than full-size (when using one of the standard up-conversion ratios at the 25 Hz H.264/AVC SDTV IRD).*

Decoding: *25 Hz H.264/AVC SDTV IRDs shall be capable of decoding pictures with luminance resolutions as shown in Table 9 and applying up sampling to allow the decoded pictures to be displayed at full-screen size. In addition, 25 Hz H.264/AVC SDTV IRDs shall be capable of decoding lower picture resolutions and displaying them at less than full-size after using one of the standard up-conversions, e.g. a horizontal resolution of 704 pixels within the 720 pixel full-screen display.*

Table 9: Resolutions for Full-screen Display from 25 Hz H.264/AVC SDTV IRD

Coded Picture			Displayed Picture Horizontal up sampling	
Luminance resolution (horizontal × vertical)	Source Aspect Ratio	Aspect_ratio_idc	4:3 Monitors	16:9 Monitors
720 × 576	4:3 16:9	2 4	× 1 × 4/3 (see note 2)	× 3/4 (see note 1) × 1
544 × 576	4:3 16:9	4 12	× 4/3 × 16/9 (see note 2)	× 1 (see note 1) × 4/3
480 × 576	4:3 16:9	10 6	× 3/2 × 2 (see note 2)	× 9/8 (see note 1) × 3/2
352 × 576	4:3 16:9	6 8	× 2 × 8/3 (see note 2)	× 3/2 (see note 1) × 2
352 × 288	4:3 16:9	2 4	× 2 × 8/3 (see note 2) (and vertical up sampling × 2)	× 3/2 (see note 1) × 2 (and vertical up sampling × 2)

NOTE 1: Up sampling of 4:3 pictures for display on a 16:9 monitor is optional in the IRD, as 16:9 monitors can be switched to operate in 4:3 mode.

NOTE 2: The up sampling with this value is applied to the pixels of the 16:9 picture to be displayed on a 4:3 monitor.

NOTE 3: It is recommended that luminance resolution of 704 pixels represents the "middle" of the picture, and that it be decoded to a 720 pixel full-screen display by placing 8 pixels of padding at each side. It is recommended that luminance resolutions, such as 352 pixels, that are natural scalings of 704 pixels, be upscaled to 704 pixels and padded as above. It is recommended that all other resolutions be scaled as indicated by the table above. Where this does not result in the expected 720 pixel full-screen display, it is recommended that the result of the scaling be clipped or padded symmetrically as required to produce a 720 pixel full-screen display.

5.6.3 30 Hz H.264/AVC SDTV IRD and Bitstream

This clause specifies the 30 Hz H.264/AVC SDTV IRD and Bitstream. All specifications in clauses 5.5 and 5.6.1 shall apply. The specification in the remainder of this clause only applies to the 30 Hz H.264/AVC SDTV IRD and Bitstream.

5.6.3.1 Colour Parameter Information

Encoding: *The chromaticity co-ordinates of the ideal display, opto-electronic transfer characteristic of the source picture and matrix coefficients used in deriving luminance and chrominance signals from the red, green and blue primaries shall be explicitly signalled in the encoded H.264/AVC bitstream by setting the appropriate values for each of the following 3 parameters in the VUI: **colour_primaries**, **transfer_characteristics**, and **matrix_coefficients**.*

It is recommended that ITU-R Recommendation BT.1700 Part A [27] colorimetry is used for video of all other vertical resolutions in the H.264/AVC bitstream, which is signalled by setting **colour_primaries** to the value 6, **transfer_characteristics** to the value 6 and **matrix_coefficients** to the value 6.

Decoding: *The 30 Hz H.264/AVC SDTV IRD shall be capable of decoding bitstreams with any allowed values of **colour_primaries**, **transfer_characteristics** and **matrix_coefficients**. It is recommended that appropriate processing be included for the accurate representation of pictures using ITU-R Recommendation BT.1700 Part A [27] colorimetry.*

NOTE: Previous editions of this document referenced SMPTE 170M colorimetry (see Bibliography). ITU-R Recommendation BT.1700 Part A [27] references SMPTE 170M.

5.6.3.2 Frame rate

Encoding: *The frame rate shall be 24 000/1 001, 24, 30 000/1 001, 30 Hz. This shall be indicated in the VUI by setting **time_scale** and **num_units_in_tick** according to Table 10. Time_scale and num_units_in_tick define the picture rate of the video.*

Table 10: time_scale and num_units_in_tick for Progressive and Interlace Frame Rates for 30 Hz H.264/AVC SDTV

Frame Rate	Interlaced or Progressive	time_scale	Num_units_in_tick
24 000/ 1 001	P	48 000	1 001
24	P	48	1
30 000/ 1 001	P	60 000	1 001
30	P	60	1
30 000/ 1 001	I	60 000	1 001
30	I	60	1

Decoding: *The 30 Hz H.264/AVC SDTV IRD shall support decoding and displaying video with a frame rate of 24 000/1 001, 24, 30 000/1 001 or 30 Hz within the constraints of Main Profile at Level 3. Support of other frame rates is optional.*

5.6.3.3 Luminance resolution

Encoding: *30 Hz H.264/AVC SDTV Bitstreams shall represent video with luminance resolutions as shown in Table 11. Non full-screen pictures may be encoded for display at less than full-size (when using one of the standard up-conversion ratios at the 30 Hz H.264/AVC SDTV IRD).*

Decoding: *30 Hz H.264/AVC SDTV IRDs shall be capable of decoding pictures with luminance resolutions as shown in Table 11 and applying up sampling to allow the decoded pictures to be displayed at full-screen size. In addition, 30 Hz H.264/AVC SDTV IRDs shall be capable of decoding lower picture resolutions and displaying them at less than full-size after using one of the standard up-conversions, e.g. a horizontal resolution of 704 pixels within the 720 pixel full-screen display.*

Table 11: Resolutions for Full-screen Display from 30 Hz H.264/AVC SDTV IRD

Coded Picture			Displayed Picture Horizontal up sampling	
Luminance resolution (horizontal × vertical)	Source Aspect Ratio	aspect_ratio_idc	4:3 Monitors	16:9 Monitors
720 × 480	4:3 16:9	3 5	× 1 × 4/3 (see note 2)	× 3/4 (see note 1) × 1
640 × 480	4:3 16:9	1 14	× 9/8 × 3/2	× 27/32 (see note 1) × 9/8
544 × 480	4:3 16:9	5 13	× 4/3 × 16/9 (see note 2)	× 1 (see note 1) × 4/3
480 × 480	4:3 16:9	11 7	× 3/2 × 2 (see note 2)	× 9/8 (see note 1) × 3/2
352 × 480	4:3 16:9	7 9	× 2 × 8/3 (see note 2)	× 3/2 (see note 1) × 2
352 × 240	4:3 16:9	3 5	× 2 × 8/3 (see note 2) (and vertical up sampling × 2)	× 3/2 (see note 1) × 2 (and vertical up sampling × 2)

NOTE 1: Up sampling of 4:3 pictures for display on a 16:9 monitor is optional in the IRD, as 16:9 monitors can be switched to operate in 4:3 mode.

NOTE 2: The up sampling with this value is applied to the pixels of the 16:9 picture to be displayed on a 4:3 monitor.

NOTE 3: It is recommended that luminance resolution of 704 pixels represents the "middle" of the picture, and that it be decoded to a 720 pixel full-screen display by placing 8 pixels of padding at each side. It is recommended that luminance resolutions, such as 352 pixels, that are natural scalings of 704 pixels, be upscaled to 704 pixels and padded as above. It is recommended that all other resolutions be scaled as indicated by the table above. Where this does not result in the expected 720 pixel full-screen display, it is recommended that the result of the scaling be clipped or padded symmetrically as required to produce a 720 pixel full-screen display.

5.7 H.264/AVC HDTV IRDs and Bitstreams

5.7.1 Specifications common to all H.264/AVC HDTV IRDs and Bitstreams

The specification in this clause applies to the following IRDs and bitstreams:

- 25 Hz H.264/AVC HDTV IRD and Bitstream;
- 30 Hz H.264/AVC HDTV IRD and Bitstream.

5.7.1.1 Sequence Parameter Set and Picture Parameter Set

Encoding: *In addition to the provisions set forth in ITU-T Recommendation H.264 | ISO/IEC 14496-10 [16], the following restrictions apply for the fields in the sequence parameter set:*

<i>profile_idc</i>	<i>= 100 (High Profile [16Error! Reference source not found.])</i>
<i>constraint_set0_flag</i>	<i>= 0</i>
<i>constraint_set1_flag</i>	<i>= 0</i>
<i>constraint_set2_flag</i>	<i>= 0</i>
<i>constraint_set3_flag</i>	<i>= 0</i>
<i>gaps_in_frame_num_value_allowed_flag</i>	<i>= 0 (gaps not allowed)</i>
<i>vui_parameters_present_flag</i>	<i>= 1</i>

5.7.1.2 Profile and level

Encoding: *H.264/AVC HDTV Bitstreams shall comply with the High Profile Level 4 restrictions, as described ISO/IEC 14496-10 [16].*

*The value of **level_idc** shall be equal to 30, 31, 32, or 40.*

Decoding: *H.264/AVC HDTV IRDs shall support the decoding of High Profile Level 4 bitstreams. This requirement includes support for High Profile and levels 3 to 4. Support for profiles and levels other than High Profile, Level 3 to 4 is optional. If the H.264/AVC HDTV IRD encounters an extension which it cannot decode, it shall discard the following data until the next start code prefix (to allow backward compatible extensions to be added in the future).*

5.7.1.3 Aspect ratio

Encoding: *The source aspect ratio in H.264/AVC HDTV Bitstreams shall be 16:9.*

The source aspect ratio information shall be derived from the **aspect_ratio_idc** value in the Video Usability Information (see values of **aspect_ratio_idc** in ITU-T Recommendation H.264 | ISO/IEC 14496-10 [16], table E-1).

The frame cropping information in the Sequence Parameter Set may be used when appropriate.

Decoding: *H.264/AVC HDTV IRDs shall support decoding and displaying H.264/AVC HDTV Bitstreams with the values of **aspect_ratio_idc** as specified in Table 12.*

The source aspect ratio information shall be derived from the **pic_height_in_map_units_minus1** and the **pic_width_in_mbs_minus1** and the frame cropping information coded in the Sequence Parameter Set as well as the sample aspect ratio encoded with the **aspect_ratio_idc** value in the Video Usability Information (see values of **aspect_ratio_idc** in ITU-T Recommendation H.264 | ISO/IEC 14496-10 [16], table E-1).

H.264/AVC HDTV IRDs shall support frame cropping.

5.7.1.4 Colour Parameter Information

Encoding: *The chromaticity co-ordinates of the ideal display, opto-electronic transfer characteristic of the source picture and matrix coefficients used in deriving luminance and chrominance signals from the red, green and blue primaries shall be explicitly signalled in the encoded H.264/AVC HDTV Bitstream by setting the appropriate values for each of the following 3 parameters in the VUI: **colour_primaries**, **transfer_characteristics**, and **matrix_coefficients**.*

It is recommended that ITU-R Recommendation BT.709 [13] colorimetry is used for all H.264/AVC HDTV Bitstreams, which is signalled by setting **colour_primaries** to the value 1, **transfer_characteristics** to the value 1 and **matrix_coefficients** to the value 1.

Decoding: *H.264/AVC HDTV IRDs shall be capable of decoding bitstreams with any allowed values of **colour_primaries**, **transfer_characteristics** and **matrix_coefficients**. It is recommended that appropriate processing be included for the accurate representation of pictures using ITU-R Recommendation BT.709 [13] colorimetry.*

5.7.1.5 Luminance resolution

Encoding: *H.264/AVC HDTV Bitstreams shall represent video with luminance resolutions as shown in Table 12. Non full-screen pictures may be encoded for display at less than full-size (when using one of the standard up-conversion ratios at the H.264/AVC HDTV IRD).*

Decoding: *H.264/AVC HDTV IRDs shall be capable of decoding pictures with luminance resolutions as shown in Table 12 and applying up sampling to allow the decoded pictures to be displayed at full-screen size.*

Table 12: Resolutions for Full-screen Display from H.264/AVC HDTV IRD

Coded Picture			
Luminance resolution (horizontal × vertical)	Source Aspect Ratio	aspect_ratio_idc	16:9 Monitors Horizontal up sampling
1 920 × 1 080	16:9	1	× 1
1 440 × 1 080	16:9	14	× 4/3
1 280 × 1 080	16:9	15	× 3/2
960 × 1 080	16:9	16	× 2
1 280 × 720	16:9	1	× 1
960 × 720	16:9	14	× 4/3
640 × 720	16:9	16	× 2

5.7.2 25 Hz H.264/AVC HDTV IRD and Bitstream

This clause specifies the 25 Hz H.264/AVC HDTV IRD and Bitstream. All specifications in clauses 5.5 and 5.7.1 shall apply. The specification in the remainder of this clause only applies to the 25 Hz H.264/AVC HDTV IRD and Bitstream.

5.7.2.1 Frame rate

Encoding: *The frame rate shall be 25 or 50 Hz. This shall be indicated in the VUI by setting **time_scale** and **num_units_in_tick** according to Table 13. Time_scale and num_units_in_tick define the picture rate of the video. The source video format for 50 Hz frame rate material shall be progressive. The source video format for 25 Hz frame rate material shall be interlaced or progressive.*

Table 13: time_scale and num_units_in_tick for Progressive and Interlace Frame Rates for 25 Hz H.264/AVC HDTV

Frame Rate	Interlaced or Progressive	time_scale	Num_units_in_tick
25	P	50	1
25	I	50	1
50	P	100	1

Decoding: *25 Hz H.264/AVC HDTV IRDs shall support decoding and displaying video with a frame rate of 25 Hz interlaced or progressive, or 50 Hz progressive within the constraints of High Profile at Level 4. Support of other frame rates is optional.*

5.7.2.2 Backwards Compatibility

Decoding: *25 Hz H.264/AVC HDTV IRDs shall be capable of decoding any bitstream that a 25 Hz H.264/AVC SDTV IRD is required to decode and resulting in the same displayed pictures as the 25 Hz H.264/AVC SDTV IRD, as described in clause 5.6.2.*

5.7.3 30 Hz H.264/AVC HDTV IRDs and Bitstreams

This clause specifies the 30 Hz H.264/AVC HDTV IRD and Bitstream. All specifications in clauses 5.5 and 5.7.1 shall apply. The specification in the remainder of this clause only applies to the 30 Hz H.264/AVC HDTV IRD and Bitstream.

5.7.3.1 Frame rate

Encoding: *The frame rate shall be 24 000/1 001, 24, 30 000/1 001, 30, 60 000/1 001 or 60 Hz. This shall be indicated in the VUI by setting **time_scale** and **num_units_in_tick** according to Table 14. Time_scale and num_units_in_tick define the picture rate of the video. The source video format for 24 000/1 001, 24, 60 000/1 001 and 60 Hz frame rate material shall be progressive. The source video format for 30 000/1 001 and 30 Hz frame rate material shall be interlaced or progressive.*

Table 14: time_scale and num_units_in_tick for Progressive and Interlace Frame Rates for 30 Hz H.264/AVC HDTV

Frame Rate	Interlaced or Progressive	time_scale	Num_units_in_tick
24 000/ 1 001	P	48 000	1 001
24	P	48	1
30 000/ 1 001	P	60 000	1 001
30	P	60	1
30 000/ 1 001	I	60 000	1 001
30	I	60	1
60 000/ 1 001	P	120 000	1 001
60	P	120	1

Decoding: *30 Hz H.264/AVC HDTV IRDs shall support decoding and displaying video with a frame rate of 30 000/1 001, 30 Hz interlaced or progressive, or 24 000/1 001, 24, 60 000/1 001 or 60 Hz progressive within the constraints of High Profile at Level 4. Support of other frame rates is optional.*

5.7.3.2 Backwards Compatibility

Decoding: *30 Hz H.264/AVC HDTV IRDs shall be capable of decoding any bitstream that a 30 Hz H.264/AVC SDTV IRD is required to decode and resulting in the same displayed pictures as the 30 Hz H.264/AVC SDTV IRD, as described in clause 5.7.2.*

5.8 25 Hz VC-1 SDTV IRDs and Bitstreams

The video encoding and video decoding shall conform to SMPTE 421M [21]. Some of the parameters and fields are not used in the DVB System and these restrictions are described below. The VC-1 IRD design shall be made under the assumption that any legal structure as permitted by SMPTE 421M [21] and the restrictions that are specified for the VC-1 IRDs may occur in the broadcast stream even if presently reserved or unused.

5.8.1 Profile, Level and Colour Difference Format

Encoding: *25 Hz VC-1 SDTV Bitstreams shall comply with the restrictions described in SMPTE 421M [21] for Advanced Profile at Level 1.*

*The value of **PROFILE** shall be equal to “11” indicating Advanced Profile. The value of **LEVEL** shall be equal to “001” indicating Level 1 or, if appropriate, “000” indicating Level 0.*

Decoding: *25 Hz VC-1 SDTV IRDs shall support decoding and displaying of Advanced Profile bitstreams at Level 1 using 4:2:0 colour difference format. Support of levels beyond Level 1 is optional. If the VC-1 IRD encounters an extension which it cannot decode, it shall discard the following data until the next start code prefix (to allow backward compatible extensions to be added in the future).*

5.8.2 Frame rate

Encoding: *The frame rate in 25 Hz VC-1 SDTV Bitstreams shall be 25 Hz. This shall be indicated by setting **FRAMERATENR** to 2 and **FRAMERATEDR** to 1.*

Decoding: *25 Hz VC-1 SDTV IRDs shall support decoding and displaying video with a frame rate of 25 Hz within the constraints of Advanced Profile at Level 1. Support of other frame rates is optional.*

5.8.3 Aspect ratio

Encoding: *The source aspect ratio in 25 Hz VC-1 SDTV Bitstreams shall be either 4:3 or 16:9. The display geometry information to optimally render the decoded picture shall be signalled by an appropriate combination of **DISP_HORIZ_SIZE**, **DISP_VERT_SIZE**, **ASPECT_RATIO**, **ASPECT_HORIZ_SIZE** and **ASPECT_VERT_SIZE**.*

Decoding: *25 Hz VC-1 SDTV IRDs shall support decoding and displaying 25 Hz VC-1 SDTV Bitstreams with source aspect ratios of either 4:3 or 16:9. It is recommended that the display process use the display geometry information signalled by **DISP_HORIZ_SIZE**, **DISP_VERT_SIZE**, **ASPECT_RATIO**, **ASPECT_HORIZ_SIZE** and **ASPECT_VERT_SIZE** to optimally render the decoded picture.*

5.8.4 Luminance resolution

Encoding: *25 Hz VC-1 SDTV Bitstreams shall represent coded video with luminance resolutions as shown in Table 15. Non full-screen pictures may be encoded for display at less than full-size, when using one of the standard up-conversion ratios at the 25 Hz VC-1 SDTV IRD (e.g. a horizontal resolution of 704 pixels within the 720 pixel full-screen display).*

Decoding: *25 Hz VC-1 SDTV IRDs shall be capable of decoding pictures with luminance resolutions as shown in Table 15 and applying up sampling to allow the decoded pictures to be displayed at full-screen size. In addition, 25 Hz VC-1 SDTV IRDs shall be capable of decoding lower picture resolutions and displaying them at less than full-size after using one of the standard up-conversions, e.g. a horizontal resolution of 704 pixels within the 720 pixel full-screen display.*

Table 15: Resolutions for Full-screen Display from 25 Hz VC-1 SDTV IRD

Coded Picture		Displayed Picture Horizontal up sampling	
Luminance resolution (horizontal × vertical)	Source Video Aspect Ratio	4:3 Monitors	16:9 Monitors
720 × 576	4:3 16:9	× 1 × 4/3 (see note 2)	× 3/4 (see note 1) × 1
544 × 576	4:3 16:9	× 4/3 × 16/9 (see note 2)	× 1 (see note 1) × 4/3
480 × 576	4:3 16:9	× 3/2 × 2 (see note 2)	× 9/8 (see note 1) × 3/2
352 × 576	4:3 16:9	× 2 × 8/3 (see note 2)	× 3/2 (see note 1) × 2
352 × 288	4:3 16:9	× 2 × 8/3 (see note 2)	× 3/2 (see note 1) × 2
		(and vertical up sampling × 2)	(and vertical up sampling × 2)

NOTE 1: Up sampling of 4:3 pictures for display on a 16:9 monitor is optional in the IRD, as 16:9 monitors can be switched to operate in 4:3 mode.

NOTE 2: The up sampling with this value is applied to the pixels of the 16:9 picture to be displayed on a 4:3 monitor.

NOTE 3: It is recommended that luminance resolution of 704 pixels represents the "middle" of the picture, and that it be decoded to a 720 pixel full-screen display by placing 8 pixels of padding at each side. It is recommended that luminance resolutions, such as 352 pixels, that are natural scalings of 704 pixels, be upscaled to 704 pixels and padded as above. It is recommended that all other resolutions be scaled as indicated by the table above. Where this does not result in the expected 720 pixel full-screen display, it is recommended that the result of the scaling be clipped or padded symmetrically as required to produce a 720 pixel full-screen display.

5.8.5 Colour Parameter Information

Encoding: *The chromaticity co-ordinates of the ideal display, opto-electronic transfer characteristic of the source picture and matrix coefficients used in deriving luminance and chrominance signals from the red, green and blue primaries shall be explicitly signalled in the encoded 25 Hz VC-1 SDTV Bitstream by setting the appropriate values for each of the following 3 parameters: **COLOR_PRIM**, **TRANSFER_CHAR** and **MATRIX_COEFF**.*

It is recommended that ITU-R Recommendation BT.1700 Part B [27] colorimetry is used in the 25 Hz VC-1 SDTV bitstream, which is signalled by setting **COLOR_PRIM** to the value 5, **TRANSFER_CHAR** to the value 5 and **MATRIX_COEFF** to the value 6.

Decoding: *25 Hz VC-1 SDTV IRDs shall support decoding bitstreams with any allowed values of **COLOR_PRIM**, **TRANSFER_CHAR** and **MATRIX_COEFF**. It is recommended that appropriate processing be included for the accurate representation of pictures using ITU-R Recommendation BT.1700 Part B [27] colorimetry.*

NOTE: Previous editions of this document referenced ITU-R Recommendation BT.470 System B, G colorimetry (see Bibliography). ITU-R Recommendation BT.1700 [27] replaces ITU-R Recommendation BT. 470.

5.8.6 Random Access Point

Encoding: Where channel change times are important it is recommended that a Sequence Header and Entry-Point Header are encoded at least once every 500 ms. In applications where channel change time is an issue but coding efficiency is critical, it is recommended that a Sequence Header and Entry-Point Header are encoded at least once every 2 s. For those applications where channel change time is not an issue, it is recommended that a Sequence Header and Entry-Point Header are sent at least once every 5 s.

NOTE 1: Increasing the frequency of Sequence Header and Entry-Point Header will reduce channel hopping time but will reduce the efficiency of the video compression.

NOTE 2: Having a regular interval between Entry-Point Headers may improve trick mode performance, but may reduce the efficiency of the video compression.

NOTE 3: The AU_information_descriptor described in Annex D provides a means of signalling information about Random Access Points that may be used by some applications, and it is recommended that this is present.

5.9 25 Hz VC-1 HDTV IRDs and Bitstreams

The video encoding and video decoding shall conform to SMPTE 421M [21]. Some of the parameters and fields are not used in the DVB System and these restrictions are described below. The VC-1 IRD design shall be made under the assumption that any legal structure as permitted by SMPTE 421M [21] and the restrictions that are specified for the VC-1 IRDs may occur in the broadcast stream even if presently reserved or unused.

5.9.1 Profile, Level and Colour Difference Format

Encoding: *25 Hz VC-1 HDTV Bitstreams shall comply with the restrictions described in SMPTE 421M [21] for Advanced Profile at Level 3.*

*The value of **PROFILE** shall be equal to "11" indicating Advanced Profile. The value of **LEVEL** shall be equal to "011" indicating Level 3 or, if appropriate, "010" indicating Level 2, "001" indicating Level 1 or "000" indicating Level 0.*

Decoding: *25 Hz VC-1 HDTV IRDs shall support decoding and displaying of Advanced Profile bitstreams at Level 3 using 4:2:0 colour difference format. Support of levels beyond Level 3 is optional. If the VC-1 IRD encounters an extension which it cannot decode, it shall discard the following data until the next start code prefix (to allow backward compatible extensions to be added in the future).*

5.9.2 Frame rate

- Encoding: *The frame rate in 25 Hz VC-1 HDTV Bitstreams shall be 25 Hz or 50 Hz. This shall be indicated by setting **FRAMERATENR** to 2 or 4, as appropriate, and **FRAMERATEDR** to 1.*
- Decoding: *25 Hz VC-1 HDTV IRDs shall support decoding and displaying video with a frame rate of 25 Hz or 50 Hz within the constraints of Advanced Profile at Level 3. Support of other frame rates is optional.*

5.9.3 Aspect ratio

- Encoding: *The source aspect ratio in 25 Hz VC-1 HDTV Bitstreams shall be 16:9. The display geometry information to optimally render the decoded picture shall be signalled by an appropriate combination of **DISP_HORIZ_SIZE**, **DISP_VERT_SIZE**, **ASPECT_RATIO**, **ASPECT_HORIZ_SIZE** and **ASPECT_VERT_SIZE**.*
- Decoding: *25 Hz VC-1 HDTV IRDs shall support decoding and displaying 25 Hz VC-1 HDTV Bitstreams with source aspect ratios of 16:9. It is recommended that the display process use the display geometry information signalled by **DISP_HORIZ_SIZE**, **DISP_VERT_SIZE**, **ASPECT_RATIO**, **ASPECT_HORIZ_SIZE** and **ASPECT_VERT_SIZE** to optimally render the decoded picture.*

5.9.4 Luminance resolution

- Encoding: *25 Hz VC-1 HDTV Bitstreams shall represent video with luminance resolutions as shown in Table 16. Non full-screen pictures may be encoded for display at less than full-size (when using one of the standard up-conversion ratios at the 25 Hz VC-1 HDTV IRD).*
- Decoding: *25 Hz VC-1 HDTV IRDs shall be capable of decoding pictures with luminance resolutions as shown in Table 16 and applying up sampling to allow the decoded pictures to be displayed at full-screen size.*

Table 16: Resolutions for Full-screen Display from 25 Hz VC-1 HDTV IRD

Luminance resolution (horizontal × vertical)	Coded Picture	
	Source Aspect Ratio	16:9 Monitors Horizontal up sampling
1 920 × 1 080	16:9	× 1
1 440 × 1 080	16:9	× 4/3
1 280 × 1 080	16:9	× 3/2
960 × 1 080	16:9	× 2
1 280 × 720	16:9	× 1
960 × 720	16:9	× 4/3
640 × 720	16:9	× 2

5.9.5 Colour Parameter Information

- Encoding: *The chromaticity co-ordinates of the ideal display, opto-electronic transfer characteristic of the source picture and matrix coefficients used in deriving luminance and chrominance signals from the red, green and blue primaries shall be explicitly signalled in the encoded 25 Hz VC-1 HDTV Bitstream by setting the appropriate values for each of the following 3 parameters: **COLOR_PRIM**, **TRANSFER_CHAR** and **MATRIX_COEFF**.*

It is recommended that ITU-R Recommendation BT.709 [13] colorimetry is used for all 25 Hz VC-1 HDTV Bitstreams, which is signalled by setting **COLOR_PRIM** to the value 1, **TRANSFER_CHAR** to the value 1 and **MATRIX_COEFF** to the value 1.

Decoding: *25 Hz VC-1 HDTV IRDs shall support decoding bitstreams with any allowed values of **COLOR_PRIM**, **TRANSFER_CHAR** and **MATRIX_COEFF**. It is recommended that appropriate processing be included for the accurate representation of pictures using ITU-R Recommendation BT.709 [13] colorimetry.*

5.9.6 Random Access Point

Encoding: Where channel change times are important it is recommended that a Sequence Header and Entry-Point Header are encoded at least once every 500 ms. In applications where channel change time is an issue but coding efficiency is critical, it is recommended that a Sequence Header and Entry-Point Header are encoded at least once every 2 s. For those applications where channel change time is not an issue, it is recommended that a Sequence Header and Entry-Point Header are sent at least once every 5 s.

NOTE 1: Increasing the frequency of Sequence Header and Entry-Point Header will reduce channel hopping time but will reduce the efficiency of the video compression.

NOTE 2: Having a regular interval between Entry-Point Headers may improve trick mode performance, but may reduce the efficiency of the video compression.

NOTE 3: The AU_information_descriptor described in Annex D provides a means of signalling information about Random Access Points that may be used by some applications, and it is recommended that this is present.

5.9.7 Backwards Compatibility

Decoding: *25 Hz VC-1 HDTV IRDs shall be capable of decoding any bitstream that a 25 Hz VC-1 SDTV IRD is required to decode and resulting in the same displayed pictures as the 25 Hz VC-1 SDTV IRD.*

5.10 30 Hz VC-1 SDTV IRDs and Bitstreams

The video encoding and video decoding shall conform to SMPTE 421M [21]. Some of the parameters and fields are not used in the DVB System and these restrictions are described below. The VC-1 IRD design shall be made under the assumption that any legal structure as permitted by SMPTE 421M [21] and the restrictions that are specified for the VC-1 IRDs may occur in the broadcast stream even if presently reserved or unused.

5.10.1 Profile and level

Encoding: *30 Hz VC-1 SDTV Bitstreams shall comply with the restrictions described in SMPTE 421M [21] for Advanced Profile at Level 1.*

*The value of **PROFILE** shall be equal to "11" indicating Advanced Profile. The value of **LEVEL** shall be equal to "001" indicating Level 1 or, if appropriate, "000" indicating Level 0.*

Decoding: *30 Hz VC-1 SDTV IRDs shall support decoding and displaying of Advanced Profile bitstreams at Level 1 using 4:2:0 colour difference format. Support of levels beyond Level 1 is optional. If the VC-1 IRD encounters an extension which it cannot decode, it shall discard the following data until the next start code prefix (to allow backward compatible extensions to be added in the future).*

5.10.2 Frame rate

Encoding: *The frame rate in 30 Hz VC-1 SDTV Bitstreams shall be 24 000/1 001, 24, 30 000/1 0001 or 30 Hz. This shall be indicated by setting **FRAMERATENR** to 1 or 3 and **FRAMERATEDR** to 1 or 2, as appropriate.*

Decoding: 30 Hz VC-1 SDTV IRDs shall support decoding and displaying video with a frame rates of 24 000/1 001, 24, 30 000/1 0001 or 30 Hz within the constraints of Advanced Profile at Level 1. Support of other frame rates is optional.

5.10.3 Aspect ratio

Encoding: The source aspect ratio in 30 Hz VC-1 SDTV Bitstreams shall be either 4:3 or 16:9. The display geometry information to optimally render the decoded picture shall be signalled by an appropriate combination of **DISP_HORIZ_SIZE**, **DISP_VERT_SIZE**, **ASPECT_RATIO**, **ASPECT_HORIZ_SIZE** and **ASPECT_VERT_SIZE**.

Decoding: 30 Hz VC-1 SDTV IRDs shall support decoding and displaying 30 Hz VC-1 SDTV Bitstreams with source aspect ratios of either 4:3 or 16:9. It is recommended that the display process use the display geometry information signalled by **DISP_HORIZ_SIZE**, **DISP_VERT_SIZE**, **ASPECT_RATIO**, **ASPECT_HORIZ_SIZE** and **ASPECT_VERT_SIZE** to optimally render the decoded picture.

5.10.4 Luminance resolution

Encoding: 30 Hz VC-1 SDTV Bitstreams shall represent coded video with luminance resolutions as shown in Table 17. Non full-screen pictures may be encoded for display at less than full-size, when using one of the standard up-conversion ratios at the 30 Hz VC-1 SDTV IRD (e.g. a horizontal resolution of 704 pixels within the 720 pixel full-screen display).

Decoding: 30 Hz VC-1 SDTV IRDs shall be capable of decoding pictures with luminance resolutions as shown in Table 17 and applying up sampling to allow the decoded pictures to be displayed at full-screen size. In addition, 30 Hz VC-1 SDTV IRDs shall be capable of decoding lower picture resolutions and displaying them at less than full-size after using one of the standard up-conversions, e.g. a horizontal resolution of 704 pixels within the 720 pixel full-screen display.

Table 17: Resolutions for Full-screen Display from 30 Hz VC-1 SDTV IRD

Coded Picture		Displayed Picture Horizontal up sampling	
Luminance resolution (horizontal × vertical)	Source Video Aspect Ratio	4:3 Monitors	16:9 Monitors
720 × 480	4:3	× 1	× 3/4 (see note 1)
	16:9	× 4/3 (see note 2)	× 1
640 × 480	4:3	× 9/8	× 27/32 (see note 1)
	16:9	× 3/2	× 9/8
544 × 480	4:3	× 4/3	× 1 (see note 1)
	16:9	× 16/9 (see note 2)	× 4/3
480 × 480	4:3	× 3/2	× 9/8 (see note 1)
	16:9	× 2 (see note 2)	× 3/2
352 × 480	4:3	× 2	× 3/2 (see note 1)
	16:9	× 8/3 (see note 2)	× 2
352 × 240	4:3	× 2	× 3/2 (see note 1)
	16:9	× 8/3 (see note 2)	× 2

NOTE 1: Up sampling of 4:3 pictures for display on a 16:9 monitor is optional in the IRD, as 16:9 monitors can be switched to operate in 4:3 mode.

NOTE 2: The up sampling with this value is applied to the pixels of the 16:9 picture to be displayed on a 4:3 monitor.

NOTE 3: It is recommended that luminance resolution of 704 pixels represents the "middle" of the picture, and that it be decoded to a 720 pixel full-screen display by placing 8 pixels of padding at each side. It is recommended that luminance resolutions, such as 352 pixels, that are natural scalings of 704 pixels, be upsampled to 704 pixels and padded as above. It is recommended that all other resolutions be scaled as indicated by the table above. Where this does not result in the expected 720 pixel full-screen display, it is recommended that the result of the scaling be clipped or padded symmetrically as required to produce a 720 pixel full-screen display.

5.10.5 Colour Parameter Information

Encoding: *The chromaticity co-ordinates of the ideal display, opto-electronic transfer characteristic of the source picture and matrix coefficients used in deriving luminance and chrominance signals from the red, green and blue primaries shall be explicitly signalled in the encoded 30 Hz VC-1 SDTV Bitstream by setting the appropriate values for each of the following 3 parameters: **COLOR_PRIM**, **TRANSFER_CHAR** and **MATRIX_COEFF**.*

It is recommended that ITU-R Recommendation BT.1700 Part A [27] colorimetry is used for 30 Hz VC-1 SDTV bitstreams, which is signalled by setting **COLOR_PRIM** to the value 6, **TRANSFER_CHAR** to the value 6 and **MATRIX_COEFF** to the value 6.

Decoding: *30 Hz VC-1 SDTV IRDs shall support decoding bitstreams with any allowed values of **COLOR_PRIM**, **TRANSFER_CHAR** and **MATRIX_COEFF**. It is recommended that appropriate processing be included for the accurate representation of pictures using ITU-R Recommendation BT.1700 Part A [27] colorimetry.*

NOTE: Previous editions of this document referenced SMPTE 170M colorimetry (see Bibliography). ITU-R Recommendation BT.1700 Part A [27] references SMPTE 170M.

5.10.6 Random Access Point

Encoding: Where channel change times are important it is recommended that a Sequence Header and Entry-Point Header are encoded at least once every 500 ms. In applications where channel change time is an issue but coding efficiency is critical, it is recommended that a Sequence Header and Entry-Point Header are encoded at least once every 2 s. For those applications where channel change time is not an issue, it is recommended that a Sequence Header and Entry-Point Header are sent at least once every 5 s.

NOTE 1: Increasing the frequency of Sequence Header and Entry-Point Header will reduce channel hopping time but will reduce the efficiency of the video compression.

NOTE 2: Having a regular interval between Entry-Point Headers may improve trick mode performance, but may reduce the efficiency of the video compression.

NOTE 3: The AU_information_descriptor described in Annex D provides a means of signalling information about Random Access Points that may be used by some applications, and it is recommended that this is present.

5.11 30 Hz VC-1 HDTV IRDs and Bitstreams

The video encoding and video decoding shall conform to SMPTE 421M [21]. Some of the parameters and fields are not used in the DVB System and these restrictions are described below. The VC-1 IRD design shall be made under the assumption that any legal structure as permitted by SMPTE 421M [21] and the restrictions that are specified for the VC-1 IRDs may occur in the broadcast stream even if presently reserved or unused.

5.11.1 Profile, Level and Colour Difference Format

Encoding: *30 Hz VC-1 HDTV Bitstreams shall comply with the restrictions described in SMPTE 421M [21] for Advanced Profile at Level 3.*

*The value of **PROFILE** shall be equal to "11" indicating Advanced Profile. The value of **LEVEL** shall be equal to "011" indicating Level 3 or, if appropriate, "010" indicating Level 2, "001" indicating Level 1 or "000" indicating Level 0.*

Decoding: *30 Hz VC-1 HDTV IRDs shall support decoding and displaying of Advanced Profile bitstreams at Level 3 using 4:2:0 colour difference format. Support of levels beyond Level 3 is optional. If the VC-1 IRD encounters an extension which it cannot decode, it shall discard the following data until the next start code prefix (to allow backward compatible extensions to be added in the future).*

5.11.2 Frame rate

- Encoding: *The frame rate in 30 Hz VC-1 HDTV Bitstreams shall be 24 000/1 001, 24, 30 000/1 0001, 30, 60 000/1 000 or 60 Hz. This shall be indicated by setting **FRAMERATENR** to 1, 3 or 5 and **FRAMERATEDR** to 1 or 2, as appropriate.*
- Decoding: *30 Hz VC-1 HDTV IRDs shall support decoding and displaying video with a frame rate of 24 000/1 001, 24, 30 000/1 0001, 30, 60 000/1 000 or 60 Hz within the constraints of Advanced Profile at Level 3. Support of other frame rates is optional.*

5.11.3 Aspect ratio

- Encoding: *The source aspect ratio in 30 Hz VC-1 HDTV Bitstreams shall be 16:9. The display geometry information to optimally render the decoded picture shall be signalled by an appropriate combination of **DISP_HORIZ_SIZE**, **DISP_VERT_SIZE**, **ASPECT_RATIO**, **ASPECT_HORIZ_SIZE** and **ASPECT_VERT_SIZE**.*
- Decoding: *30 Hz VC-1 HDTV IRDs shall support decoding and displaying 30 Hz VC-1 HDTV Bitstreams with source aspect ratios of 16:9. It is recommended that the display process use the display geometry information signalled by **DISP_HORIZ_SIZE**, **DISP_VERT_SIZE**, **ASPECT_RATIO**, **ASPECT_HORIZ_SIZE** and **ASPECT_VERT_SIZE** to optimally render the decoded picture.*

5.11.4 Luminance resolution

- Encoding: *30 Hz VC-1 HDTV Bitstreams shall represent video with luminance resolutions as shown in Table 18. Non full-screen pictures may be encoded for display at less than full-size (when using one of the standard up-conversion ratios at the 30 Hz VC-1 HDTV IRD).*
- Decoding: *30 Hz VC-1 HDTV IRDs shall be capable of decoding pictures with luminance resolutions as shown in Table 18 and applying up sampling to allow the decoded pictures to be displayed at full-screen size.*

Table 18: Resolutions for Full-screen Display from 30 Hz VC-1 HDTV IRD

Luminance resolution (horizontal × vertical)	Coded Picture	
	Source Aspect Ratio	16:9 Monitors Horizontal up sampling
1 920 × 1 080	16:9	× 1
1 440 × 1 080	16:9	× 4/3
1 280 × 1 080	16:9	× 3/2
960 × 1 080	16:9	× 2
1 280 × 720	16:9	× 1
960 × 720	16:9	× 4/3
640 × 720	16:9	× 2

5.11.5 Colour Parameter Information

- Encoding: *The chromaticity co-ordinates of the ideal display, opto-electronic transfer characteristic of the source picture and matrix coefficients used in deriving luminance and chrominance signals from the red, green and blue primaries shall be explicitly signalled in the encoded 30 Hz VC-1 HDTV Bitstream by setting the appropriate values for each of the following 3 parameters: **COLOR_PRIM**, **TRANSFER_CHAR** and **MATRIX_COEFF**.*

It is recommended that ITU-R Recommendation BT.709 [13] colorimetry is used for all 30 Hz VC-1 HDTV Bitstreams, which is signalled by setting **COLOR_PRIM** to the value 1, **TRANSFER_CHAR** to the value 1 and **MATRIX_COEFF** to the value 1.

Decoding: *30 Hz VC-1 HDTV IRDs shall support decoding bitstreams with any allowed values of **COLOR_PRIM**, **TRANSFER_CHAR** and **MATRIX_COEFF**. It is recommended that appropriate processing be included for the accurate representation of pictures using ITU-R Recommendation BT.709 [13] colorimetry.*

5.11.6 Random Access Point

Encoding: Where channel change times are important it is recommended that a Sequence Header and Entry-Point Header are encoded at least once every 500 ms. In applications where channel change time is an issue but coding efficiency is critical, it is recommended that a Sequence Header and Entry-Point Header are encoded at least once every 2 s. For those applications where channel change time is not an issue, it is recommended that a Sequence Header and Entry-Point Header are sent at least once every 5 s.

NOTE 1: Increasing the frequency of Sequence Header and Entry-Point Header will reduce channel hopping time but will reduce the efficiency of the video compression.

NOTE 2: Having a regular interval between Entry-Point Headers may improve trick mode performance, but may reduce the efficiency of the video compression.

NOTE 3: The AU_information_descriptor described in Annex D provides a means of signalling information about Random Access Points that may be used by some applications, and it is recommended that this is present.

5.11.7 Backwards Compatibility

Decoding: *30 Hz VC-1 HDTV IRDs shall be capable of decoding any bitstream that a 30 Hz VC-1 SDTV IRD is required to decode and resulting in the same displayed pictures as the 30 Hz VC-1 SDTV IRD.*

6 Audio

This clause describes the guidelines for encoding MPEG-1 or MPEG-2 layer 2 backward compatible audio, or AC-3 audio, or Enhanced AC-3 audio, or DTS audio, or MPEG-4 AAC audio, or MPEG-4 HE-AAC audio, or MPEG-4 HE AACv2 audio in DVB broadcast bit-streams, and for decoding this bitstream in the IRD.

The recommended level for reference tones for transmission is 18 dB below clipping level, in accordance with EBU Recommendation R.68 [11].

6.1 MPEG-1 and MPEG-2 backward compatible audio

The audio encoding shall conform to either ISO/IEC 11172-3 [9] or ISO/IEC 13818-3 [3]. Some of the parameters and fields in ISO/IEC 11172-3 [9] and ISO/IEC 13818-3 [3] are not used in the DVB System and these restrictions are described below.

The IRD design should be made under the assumption that any legal structure as permitted by ISO/IEC 11172-3 [9] or ISO/IEC 13818-3 [3] may occur in the broadcast stream even if presently reserved or unused. To allow full compliance to ISO/IEC 11172-3 [9] and ISO/IEC 13818-3 [3] and upward compatibility with future enhanced versions, a DVB IRD shall be able to skip over data structures which are currently "reserved", or which correspond to functions not implemented by the IRD. For example, an IRD which is not designed to make use of the ancillary data field shall skip over that portion of the bit-stream.

This clause is based on ISO/IEC 11172-3 [9] (MPEG-1 audio) and ISO/IEC 13818-3 [3] (MPEG-2 backward compatible audio).

6.1.1 Audio mode

Encoding: *The audio shall be encoded in one of the following modes:*

- ISO/IEC 11172-3 [9] single channel;
- ISO/IEC 11172-3 [9] joint stereo;

- ISO/IEC 11172-3 [9] stereo;
- ISO/IEC 13818-3 [3] multi-channel audio, backwards compatible to ISO/IEC 11172-3 [9] (dematrix procedure = 0, 1 or 2).

In addition, audio may be encoded in ISO/IEC 11172-3 [9] dual channel mode, as specified by TR 102 154, in a transmission intended both as a contribution feed and for direct-to-home (DTH) reception. However, this is not recommended. Care needs to be taken to ensure that the optional dual channel decoding mode is supported in the DTH IRD. Furthermore, there may be problems due to the left/right channel selection being performed by different equipment from the decoding unit (e.g. decoding may be by a set-top-box but left/right channel selection and audio balance may be performed by the TV set).

Decoding: *The IRD shall be capable of decoding the following audio modes:*

- ISO/IEC 11172-3 [9] single channel;
- ISO/IEC 11172-3 [9] joint stereo;
- ISO/IEC 11172-3 [9] stereo.

The IRD shall be capable of decoding at least the ISO/IEC 11172-3 [9] compatible basic stereo information from an ISO/IEC 13818-3 [3] multi-channel audio bit-stream. Full decoding of an ISO/IEC 13818-3 [3] multi-channel audio bit-stream is optional.

Support for decoding of ISO/IEC 11172-3 [9] dual channel is optional.

6.1.2 Layer

Encoding: *An ISO/IEC 11172-3 [9] encoded bit-stream shall use either Layer I or Layer II coding (**layer** = "11" or "10" respectively). Use of Layer II is recommended.*

*An ISO/IEC 13818-3 [3] multi-channel encoded bit-stream shall use Layer II coding (**layer** = "10").*

Decoding: *IRDs shall be capable of decoding Layer I and Layer II.*

6.1.3 Bit rate

Encoding: *The value of **bitrate_index** in the encoded bit-stream shall be one of the 14 values from "0001" to "1110"(inclusive).*

For Layer I, these correspond to bit rates of: 32 kbits/s, 64 kbits/s, 96 kbits/s, 128 kbits/s, 160 kbits/s, 192 kbits/s, 224 kbits/s, 256 kbits/s, 288 kbits/s, 320 kbits/s, 352 kbits/s, 384 kbits/s, 416 kbits/s or 448 kbits/s.

For Layer II, these correspond to bit rates of: 32 kbits/s, 48 kbits/s, 56 kbits/s, 64 kbits/s, 80 kbits/s, 96 kbits/s, 112 kbits/s, 128 kbits/s, 160 kbits/s, 192 kbits/s, 224 kbits/s, 256 kbits/s, 320 kbits/s, 384 kbits/s.

For ISO/IEC 13818-3 [3] encoded bit-streams with total bit rates greater than 384 kbit/s, an extension bit-stream shall be used. The bit rate of that extension may be in the range of 0 to 682 kbit/s.

Decoding: *IRDs shall be capable of decoding bit-streams with a value of **bitrate_index** from "0001" to "1110"(inclusive). Support for the free format bit rate (**bitrate_index** = "0000") is optional.*

6.1.4 Sampling frequency

Encoding: *The audio sampling rate of primary sound services shall be 32 kHz, 44,1 kHz or 48 kHz. Sampling rates of 16 kHz, 22,05 kHz, 24 kHz, 32 kHz, 44,1 kHz or 48 kHz may be used for secondary sound services.*

Decoding: *The IRD shall be capable of decoding audio with sampling rates of 32 kHz, 44,1 kHz and 48 kHz. Support for sampling rates of 16 kHz, 22,05 kHz and 24 kHz is optional.*

6.1.5 Emphasis

Encoding: *The encoded bit-stream shall have no emphasis (**emphasis** = "00").*

Decoding: *The IRD shall be capable of decoding audio with no emphasis. Support for 50/15 microseconds de-emphasis and ITU-T Recommendation J.17 [10] de-emphasis (**emphasis** = "01" or "11") is optional.*

6.1.6 Cyclic redundancy code

Encoding: *The parity check word (**crc_check**) shall be included in the encoded bit-stream.*

Decoding: *It is recommended that the IRD use **crc_check** to detect errors and subsequently invoke suitable concealment or muting mechanisms.*

6.1.7 Prediction

Encoding: *ISO/IEC 13818-3 [3] multichannel encoded bit-streams shall not use **mc_prediction** (**mc_prediction_on** equals "0").*

Decoding: *The IRD shall be capable of decoding ISO/IEC 13818-3 [3] multichannel encoded bit-streams which do not use **mc_prediction**.*

6.1.8 Multilingual

Encoding: *ISO/IEC 13818-3 [3] multichannel encoded bit-streams shall not contain multilingual channels (**no_of_multilingual_channels** equals "0").*

Decoding: *The IRD shall be capable of decoding ISO/IEC 13818-3 [3] multichannel encoded bit-streams which do not contain multilingual channels.*

6.1.9 Extension Stream

Encoding: *When an ISO/IEC 13818-3 [3] encoded bit-stream uses an extension stream, it is recommended that a continuous stream of extension frames is maintained for the duration of a programme, even if a total bit rate of less than 384 kbits/s would be sufficient to encode individual frames. This prevents undesired resets of the audio decoder.*

6.1.10 Ancillary Data

Encoding: *ISO/IEC 13818-3 [3] stereo or multichannel encoded bitstreams may contain ancillary data as described in Annex C. It is recommended to include the data in the bitstream.*

- *In order to support the contribution of DAB signals, the ancillary data field may embed the DAB ancillary data field [19]*
- *In order to support the transmission of RDS data to DVB receivers and analogue UKW/FM transmitters, the ancillary data field may embed RDS data via the UECP protocol*
- *If data fields according to DVD-Video extended ancillary data (as described in Annex C) or ancillary data according to the DAB specification [19] are used, they have, for backward compatibility reasons, to be the first data field at the end of the audio frame. This means that a common usage of DVD-Video and DAB data is excluded.*

Decoding: *The IRD may interpret the ancillary data field in an ISO/IEC 13818-3 [3] stereo or multichannel bitstream as described in Annex C and it is recommended that the contribution IRD make use of this data.*

6.2 AC-3 and Enhanced AC-3 audio

The coding and decoding of AC-3 and Enhanced AC-3 elementary streams is based upon ETSI TS 102 366 [12].

IRDs compatible with AC-3 shall decode all bit rates and sample rates listed in TS 102 366 [12] (not including annex E).

IRDs compatible with Enhanced AC-3 shall additionally decode Enhanced AC-3 streams with data rates from 32 kbps to 3 024 kbps and support all sample rates listed in TS 102 366 [12] annex E.

Enhanced AC-3 bit streams are similar in nature to standard AC-3 bit streams, but are not backwards compatible (i.e., they are not decodable by standard AC-3 decoders). Some constraints are placed on the PES layer for the case of multiple audio streams intended to be reproduced in exact sample synchronism as described in clause 6.2.1.

6.2.1 AC-3 and Enhanced AC-3 PES constraints

6.2.1.1 Encoding

In some applications, the audio decoder may be capable of simultaneously decoding two elementary streams containing different programme elements, and then combining the programme elements into a complete programme.

Most of the programme elements are found in the main audio service. Another programme element (such as a spoken narration of the picture content intended for the visually impaired listener, a specially created dialogue based audio service for the hearing impaired listener, or additional audio services such as a spoken director's commentary or alternative languages) may be found in an associated audio service.

In order to have the audio from the two elementary streams reproduced in exact sample synchronism, it is necessary for the original audio elementary stream encoders to have encoded the two audio programme elements frame synchronously; i.e., if audio stream 1 has sample 0 of frame n taken at time t_0 , then audio stream 2 should also have frame n beginning with its sample 0 taken the identical time t_0 . *If the encoding of multiple audio services is done frame and sample synchronous, and decoding is intended to be frame and sample synchronous, then the PES packets of these audio services shall contain identical values of PTS, which refer to the audio access units intended for synchronous decoding.*

Audio services intended to be combined together for reproduction according to the mixing process defined in TS 102 366 [12](annex E) shall meet the following constraints:

- *Audio services intended to be combined together for reproduction shall be encoded at an identical sample rate.*
- *The main programme audio shall be encoded as either an AC-3 or an Enhanced AC-3 elementary stream. The associated audio service shall be encoded as an Enhanced AC-3 elementary stream.*
- *The Enhanced AC-3 elementary stream carrying the associated audio service shall contain mixing metadata for use by the decoder to control the mixing process.*
- *The main programme shall contain from 1 to 5.1 channels of audio. The Enhanced AC-3 elementary stream that carries the associated audio services to be mixed with the main programme audio shall contain no more than two audio channels, and shall not contain more audio channels than the main audio programme.*
- *Dual-mono coding mode is not supported for either the main programme or associated audio service.*
- *The encoding of the associated audio service and subsequent creation of the associated audio service elementary stream shall be done with knowledge of the encoding of the main programme stream.*
- *The pgmscl field in the associated programme bitstream should be set to a positive value. It is recommended this be positive 12 dB to match the default user volume adjustment setting in the decoder.*

6.2.1.2 Decoding

If audio access units from two audio services which are to be simultaneously decoded have identical values of PTS indicated in their corresponding PES headers, then the corresponding audio access units shall be presented to the

audio decoder for simultaneous synchronous decoding. Synchronous decoding means that for corresponding audio frames (access units), corresponding audio samples are presented at the identical time.

If the PTS values do not match (indicating that the audio encoding was not frame synchronous) then the audio frames (access units) of the main audio service may be presented to the audio decoder for decoding and presentation at the time indicated by the PTS. An associated service, which is being simultaneously decoded, may have its audio frames (access units), which are in closest time alignment (as indicated by the PTS) to those of the main service being decoded, presented to the audio decoder for simultaneous decoding. In this case the associated service may be reproduced out of sync by as much as 1/2 of a frame time. (This is typically satisfactory; a visually impaired narration does not require highly precise timing.)

A minimum functionality mixer is described in clause E.4 of TS 102 366 [12]. IRDs that implement this mixing method shall set the default user volume adjustment of the associated programme level to minus 12 dB.

The IRD may use the ISO 639 language descriptor to indicate the language of the content of the associated programme. As the associated services are carried in separate elementary streams to the main service different languages may be indicated for each programme stream.

6.2.1.3 Byte-alignment

The AC-3 and Enhanced AC-3 elementary stream shall be byte-aligned within the MPEG-2 data stream. This means that the initial 8 bits of an AC-3 or Enhanced AC-3 frame shall reside in a single byte, which is carried by the MPEG-2 data stream.

6.2.2 Enhanced AC-3 with multiple independent substreams – PES constraints

6.2.2.1 Encoding

In some applications, the audio decoder may be capable of simultaneously decoding two different programme elements, carried as separate independent substreams within a single Enhanced AC-3 elementary stream, and then combining the programme elements into a complete programme.

Most of the programme elements are found in the main audio service. Another programme element (such as a spoken narration of the picture content intended for the visually impaired listener, a specially created dialogue based audio service for the hearing impaired listener or additional audio services such as a spoken director's commentary) may be found in one or more independent substreams carried in the same Enhanced AC-3 bitstream as the main programme.

The Enhanced AC-3 elementary stream shall contain no more than three independent substreams in addition to the independent substream containing the main audio programme. The main audio programme shall only be delivered in independent substream 0.

In order to have the independent substreams containing audio from the main programme and the associated audio service reproduced in exact sample synchronism, it is necessary for the Enhanced AC-3 encoder to have encoded all of the audio programme elements frame synchronously; i.e., if the independent substream 0 has sample 0 of frame n taken at time t_0 , then independent substream 1 should also have frame n beginning with its sample 0 taken the identical time t_0 .

Independent substreams intended to be combined together for reproduction according to the mixing process defined in TS 102 366 [12] (annex E) shall meet the following constraints:

- *Independent substreams intended to be combined together for reproduction shall be encoded at an identical sample rate.*
- *The independent substream carrying the associated audio service shall contain mixing metadata for use by the decoder to control the mixing process.*
- *The independent substream that carries the main programme shall contain from 1 to 5.1 channels of audio. The independent substream that carries the associated audio services to be mixed with the main programme audio shall contain no more than two audio channels, and shall not contain more audio channels than the main audio programme.*

- *Dual-mono coding mode is not supported for either the main programme or associated audio service.*
- *The encoding of the associated audio service and subsequent creation of the associated audio service substream shall be done with knowledge of the encoding of the main programme substream.*
- *The pgmscl field in the associated programme substream should be set to a positive value. It is recommended this be positive 12 dB to match the default user volume adjustment setting in the decoder.*

6.2.2.2 Decoding

IRDs shall be able to accept Enhanced AC-3 elementary streams that contain more than one independent substream.

For TV-broadcasting applications, noticeably public service broadcasting, there is often a requirement for commentary or narration audio services to provide for different languages or Visually Impaired or Hearing Impaired audiences. To allow cost effective transmission and reproduction of these services it is strongly recommended that IRDs be able to select additional independent substreams carried in an Enhanced AC-3 elementary stream and mix the selected independent substream with the main audio programme. A minimum functionality mixer is described in clause E.4 of TS 102 366 [12]. IRDs that include this mixing capability shall set the default user volume adjustment of the associated programme level to minus 12 dB.

The IRD may use the ISO 639 language descriptor to indicate the language of the content of the main programme. As the associated programmes are carried in the same elementary stream as the main programme, the IRD shall assume that the language of associated programmes carried in independent substreams is the same as that of the main programme. To deploy associated programmes with different languages than the main programme, separate Enhanced AC-3 elementary streams shall be used, as described in clauses 6.2.1.1 and 6.2.1.2.

IRDs that support multiple different output-interfaces, for example headphone output or baseband analogue outputs, may optionally support separate mixes for each output created by multiple Enhanced AC-3 decoders.

6.3 DTS audio

The coding and decoding of DTS coded elementary streams is based upon ETSI TS 102 114 [15].

IRDs shall decode all bit rates and sample rates listed in ETSI TS 102 114 [15].

Some constraints are placed on the PES layer for the case of multiple audio streams intended to be reproduced in exact sample synchronism as described in clause 6.3.1.

6.3.1 DTS PES Constraints

6.3.1.1 Encoding

In some applications, the audio decoder may be capable of simultaneously decoding two elementary streams containing different programme elements, and then combining the programme elements into a complete programme.

Most of the programme elements are found in the main audio service. Another programme element (such as a narration of the picture content intended for the visually impaired listener) may be found in the associated audio service.

In order to have the audio from the two elementary streams reproduced in exact sample synchronism, it is necessary for the original audio elementary stream encoders to have encoded the two audio programme elements frame synchronously; i.e., if audio stream 1 has sample 0 of frame n taken at time t_0 , then audio stream 2 should also have frame n beginning with its sample 0 taken the identical time t_0 . *If the encoding of multiple audio services is done frame and sample synchronous, and decoding is intended to be frame and sample synchronous, then the PES packets of these audio services shall contain identical values of PTS, which refer to the audio access units intended for synchronous decoding.*

Audio services intended to be combined together for reproduction shall be encoded at an identical sample rate.

6.3.1.2 Decoding

If audio access units from two audio services which are to be simultaneously decoded have identical values of PTS indicated in their corresponding PES headers, then the corresponding audio access units shall be presented to the audio decoder for simultaneous synchronous decoding. Synchronous decoding means that for corresponding audio frames (access units), corresponding audio samples are presented at the identical time.

If the PTS values do not match (indicating that the audio encoding was not frame synchronous) then the audio frames (access units) of the main audio service may be presented to the audio decoder for decoding and presentation at the time indicated by the PTS. An associated service, which is being simultaneously decoded, may have its audio frames (access units), which are in closest time alignment (as indicated by the PTS) to those of the main service being decoded, presented to the audio decoder for simultaneous decoding. In this case the associated service may be reproduced out of sync by as much as 1/2 of a frame time. (This is typically satisfactory; a visually impaired narration does not require highly precise timing.)

6.3.1.3 Byte-alignment

The DTS elementary stream shall be byte-aligned within the MPEG-2 data stream. This means that the initial 8 bits of a DTS frame shall reside in a single byte, which is carried by the MPEG-2 data stream.

6.4 MPEG-4 AAC, MPEG-4 HE-AAC and MPEG-4 HE-AAC v2 audio

The coding and decoding of MPEG-4 AAC, MPEG-4 HE AAC and MPEG-4 HE AAC v2 elementary streams is based upon ISO/IEC 14496-3 [17].

The MPEG-4 AAC and the MPEG-4 HE AAC profiles are subsets of the MPEG-4 HE AAC v2 profile. The MPEG-4 HE AAC adds the AOT SBR to the MPEG-4 AAC profile. The MPEG-4 HE AAC v2 Profile adds the AOT PS to the MPEG-4 HE AAC profile to improve the audio quality at low bit rates. Every HE AAC decoder can decode an HE AAC v2 bitstream, but will not be able to use the parametric stereo information and will therefore replay on a mono signal.

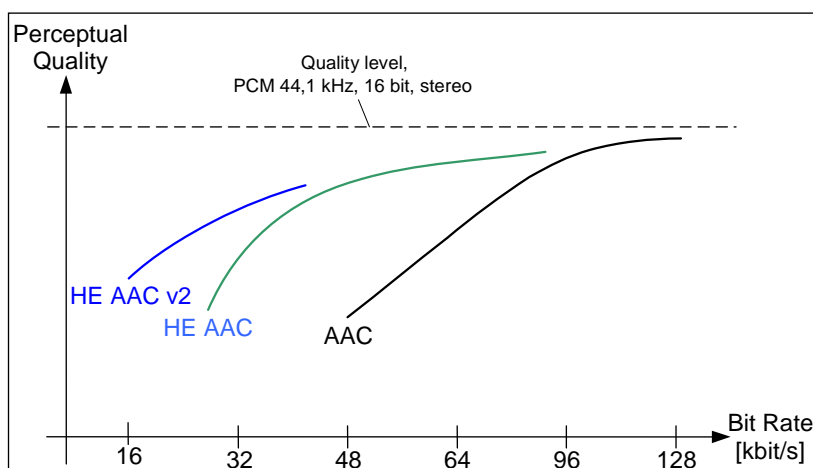

Figure 1: Typical bit rate range of the HE AAC v2, HE AAC and AAC for stereo

Figure 1 indicates the typical bit rate ranges for the use of MPEG-4 HE AAC v2, MPEG-4 HE AAC and MPEG-4 AAC on the encoder side for stereo. The actual bit rates for the use of the different tools is dependent from the encoder implementation.

6.4.1 LATM/LOAS formatting

The MPEG-4 HE AAC or HE AAC v2 elementary stream data shall be first encapsulated in the LATM multiplex format according to ISO/IEC 14496-3 [17]. The **AudioMuxElement()** multiplex element format shall be used.

The LATM formatted MPEG-4 HE AAC or HE AAC v2 elementary stream data shall be encapsulated in the LOAS transmission format according to ISO/IEC 14496-3 [17]. The `AudioSyncStream()` version shall be used. `AudioSyncStream()` adds a sync word to the audio stream to allow for synchronization. Semantics: The semantics of the `AudioMuxElement()` and `AudioSyncStream()` formatting are described in ISO/IEC 14496-3 [17].

Encoding: The MPEG-4 HE AAC and HE AAC v2 elementary streams shall be formatted with `AudioMuxElement()` LATM multiplex format, and `AudioSyncStream()` LOAS transmission format.

The following limitations to the LATM multiplex shall apply;

- **numLayer** shall be "0", as no scalable profile is used;
- **numProgram** shall be "0", as there is only one audio program per LATM multiplex;
- **numSubFrames** shall be "0", as there is only one **PayloadMux()** (access unit) per LATM **AudioMuxElement()**;
- **allStreamsSameTimeFraming** shall be "1", as all payloads belong to the same access unit.

Decoding: These formats shall be read by the IRD, and the IRD shall interpret these formats in accordance with MPEG-4 audio syntax.

6.4.2 Profiles and Levels

MPEG-4 HE AAC and HE AAC v2 is defined in the HE AAC and the HE AAC v2 profile. For Monaural, Parametric Stereo and Stereo, MPEG-4 HE AAC v2 bit-streams will comply with level 2. For Monaural and Stereo, MPEG-4 HE AAC bit-streams will comply with level 2. For multichannel, up to 5.1 channels, MPEG-4 HE AAC and HE AAC v2 bit-streams will comply with level 4.

Encoding: The encoder shall use either the MPEG-4 AAC LC Profile, the MPEG-4 HE AAC Profile or the MPEG-4 HE AAC v2 Profile. Use of the MPEG-4 HE AAC Profile is recommended.

Bit-streams including support for MPEG-4 HE AAC v2 monaural, parametric stereo and stereo shall comply with the HE AAC v2 Profile Level 2 restrictions.

Bit-streams including support for MPEG-4 HE AAC monaural and stereo shall comply with the HE AAC Profile Level 2 restrictions.

Bit-streams including support for MPEG-4 HE AAC or HE AAC v2 multichannel shall comply with the HE AAC or HE AAC v2 Profile Level 4 restrictions respectively.

Decoding: The IRD shall be capable of decoding the MPEG-4 HE AAC or the MPEG-4 HE AAC v2 Profile.

A MPEG-4 HE AAC v2 monaural, parametric stereo and stereo enabled decoder shall support MPEG-4 HE AAC v2 Level 2 bitstreams. This requirement does include support for lower levels, but not other profiles. Support for other profiles and for levels beyond Level 2 is optional.

A MPEG-4 HE AAC monaural and stereo enabled decoder shall support MPEG-4 HE AAC Level 2 bitstreams. This requirement does include support for lower levels, but not other profiles. Support for other profiles and for levels beyond Level 2 is optional.

MPEG-4 HE AAC or HE AAC v2 multi-channel enabled decoder shall support MPEG-4 HE AAC or HE AAC v2 Level 4 bitstreams respectively. This requirement does include support for lower levels, but not other profiles. Support for other profiles and for levels beyond Level 4 is optional.

If an IRD supports more than Level 2 then it shall also support Matrix-Mixdown. It shall further support the application of `downmixing_levels_MPEG4` in ancillary data (Annex C).

6.4.3 Dynamic Range Control

The MPEG-4 AAC Dynamic Range Control (DRC) tool is defined in ISO/IEC 14496-3 [17], clause 4.5.2.7. The default level for the program reference level as referred to in clause 4.5.2.7.3 shall be -31.75 dB, which corresponds to **prog_ref_level = 127**. For more detailed information on the MPEG-4 AAC Dynamic Range Control tool see ISO/IEC 14496-3 [17].

Encoding: The encoder may use the MPEG-4 AAC Dynamic Range Control (DRC) tool.

Decoding: *Each IRD shall support the MPEG-4 AAC Dynamic Range Control (DRC) tool. In case no DRC data is transmitted by the encoder, the decoder shall not apply the DRC tool.*

Annex A (informative): Examples of Full screen luminance resolutions for SDTV and HDTV

Table A.1: Examples of MPEG-2 screen resolution

vertical_size value	horizontal_size value	aspect_ratio information	frame_rate code (see note)	Progressive or Interlace	Decodeable by MPEG-2 SDTV IRD
1 080	1 920	16:9	25	P	N
1 080	1 920	16:9	23.976, 24, 29.97, 30	P	N
1 080	1 920	16:9	25	I	N
1 080	1 920	16:9	29.97, 30	I	N
720	1280	16:9	25, 50	P	N
720	1 280	16:9	23.976, 24, 29.97, 30, 59.94, 60	P	N
576	720	16:9	50	P	N
576	720	4:3, 16:9	25	P	Y
576	720	4:3, 16:9	25	I	Y
576	544	4:3, 16:9	25	P	Y
576	544	4:3, 16:9	25	I	Y
576	480	4:3, 16:9	25	P	Y
576	480	4:3, 16:9	25	I	Y
576	352	4:3, 16:9	25	P	Y
576	352	4:3, 16:9	25	I	Y
480	720	16:9	59.94, 60	P	N
480	720	4:3, 16:9	23.976, 24, 29.97, 30	P	Y
480	720	4:3, 16:9	29.97, 30	I	Y
480	640	4:3	23.976, 24, 29.97, 30	P	Y
480	640	4:3	29.97, 30	I	Y
480	544	4:3, 16:9	23.976, 29.97	P	Y
480	544	4:3, 16:9	29.97	I	Y
480	480	4:3, 16:9	23.976, 29.97	P	Y
480	480	4:3, 16:9	29.97	I	Y
480	352	4:3, 16:9	23.976, 29.97	P	Y
480	352	4:3, 16:9	29.97	I	Y
288	352	4:3, 16:9	25	P	Y
240	352	4:3, 16:9	23.976, 29.97	P	Y

NOTE: Shaded "frame_rate_code" values indicate 30 Hz bitstreams, clear values 25 Hz bitstreams.

Table A.2: Examples of H.264/AVC Screen Resolution

Vertical size	Horizontal size	Aspect ratio	Frame rate (see note)	Progressive or Interlaced	Decodable by H.264/AVC SDTV IRD
1 080	1 920, 1 440, 1 280, 960	16:9	23.976, 24	P	N
			25	I	N
			29.97, 30	P	N
			29.97, 30	I	N
720	1 280, 960, 640	16:9	25, 50	P	N
			23.976, 24, 29.97, 30, 59.94, 60	P	N
576	720	4:3, 16:9	25	P	Y
	544, 480, 352	4:3, 16:9	25	I	Y
				P	Y
				I	Y
480	720, 640, 544, 480, 352	4:3, 16:9	23.976, 24, 29.97, 30	P	Y
			29.97, 30	I	Y
288	352	4:3	25, 50	P	Y
			25	I	Y
240	352	4:3	23.976, 24, 29.97, 30, 59.94, 60	P	Y
			29.97, 30	I	Y

NOTE: Shaded "frame_rate_code" values indicate 30 Hz bitstreams, clear values 25 Hz bitstreams.

Table A.3: Examples of VC-1 screen resolution

Vertical size	Horizontal size	Aspect ratio	Frame rate (see note)	Progressive or Interlaced	Decodable by VC-1 SDTV IRD
1 080	1 920, 1 440, 1 280, 960	16:9	23.976, 24	P	N
			25	I	N
			29.97, 30	P	N
			29.97, 30	I	N
720	1 280, 960, 640	16:9	25, 50	P	N
			23.976, 24, 29.97, 30, 59.94, 60	P	N
576	720	4:3, 16:9	25	P	Y
	544, 480, 352	4:3, 16:9	25	I	Y
				P	Y
				I	Y
480	720, 640, 544, 480, 352	4:3, 16:9	23.976, 24, 29.97, 30	P	Y
			29.97, 30	I	Y
288	352	4:3	25, 50	P	Y
			25	I	Y
240	352	4:3	23.976, 24, 29.97, 30, 59.94, 60	P	Y
			29.97, 30	I	Y

NOTE: Shaded "frame_rate" values indicate 30 Hz bitstreams, clear values 25 Hz bitstreams.

Annex B (informative): Auxiliary Data in the Video Elementary Stream

B.1 Overview

Certain picture-related types of data may be carried in the video elementary stream. While the “outer wrapper” is codec dependent, the basic data structures are shared in common between MPEG-2, H.264/AVC, and VC-1. These picture-related data types include Active Format Description (AFD), bar data, and North American-style closed captions.

Transmission of these descriptions, and use of these descriptions by a receiver, are both optional.

B.2 Common Syntax and Semantics

The payload is identified by use of several identifier values. Each one specifies the underlying payload syntax. In the case of the **DVB1_data()** structure, there is an additional sub-identifier and several sub-structures are used.

Table B.1: Values for user_identifier

user_identifier	user_structure()
0x47413934 (“GA94”)	DVB1_data()
0x44544731 (“DTG1”)	afd_data()

NOTE: Values of the user_identifier are registered with SMPTE-RA.

user_identifier: A 32 bit field whose value indicates the contents of the **user_structure()** as indicated in Table B.1.

user_structure() – This is a variable length data structure defined by the value of **user_identifier** and Table B.1. The two possible structures are shown in Table B.2 and Table B.3.

Table B.2: afd_data() Syntax

Syntax	No. of Bits	Identifier
afd_data() {		
'0'	1	bslbf
active_format_flag	1	bslbf
reserved (set to '00 0001')	6	bslbf
if (active_format_flag == 1) {		
reserved (set to '1111')	4	bslbf
active_format	4	bslbf
}		
}		

active_format_flag: A 1 bit flag. A value of '1' indicates that an active format is described in this data structure.

active_format: A 4 bit field describing the "area of interest" in terms of its aspect ratio within the coded frame.

Table B.3: DVB1_data() Syntax

Syntax	No. of Bits	Identifier
DVB1_data() {		
user_data_type_code	8	uimsbf
user_data_type_structure()		
}		

user_data_type_code: An 8-bit value that identifies the type of user data to follow in the **user_data_type_structure()**. The values are defined in Table B.4.

Table B.4: Values for user_data_type_code

user_data_type_code	user_data_type_structure()
0x00 – 0x02	DVB Reserved
0x03	cc_data()
0x04	DVB Reserved
0x05	DVB Reserved
0x06	bar_data()
0x07 – 0xFF	DVB Reserved

user_data_type_structure: This is a variable length set of data defined by the value of **user_data_type_code** and Table B.7 (bar data) or Table B.9 (closed captions).

B.3 Active Format Description (AFD)

The AFD describes the portion of the coded video frame that is "of interest". It is intended for use in networks that deliver mixed formats to a heterogeneous receiver population. The format descriptions are informative in nature and are provided to assist receiver systems to optimize their presentation of video. The AFD may be supplemented by "bar data," which describes the size of either a pair of top and bottom bars ("letterbox") or a pair of side bars ("pillarbox"). This permits a display of either 4:3 or 16:9 aspect ratio to best display a picture of any aspect ratio.

The AFD is intended for use where there are compatibility problems between the source format of a programme, the format used for the transmission of that programme, and the format of the target receiver population. For example, a wide-screen production may be transmitted as a 14:9 letter-box within a 4:3 coded frame, thus optimized for the viewer of a 4:3 TV, but causing problems to the viewer of a wide screen TV. The appropriate AFD may be transmitted with the video to indicate to the receiver the "area of interest" of the image, thereby enabling a receiver to present the image in an optimum fashion (which will depend on the format and functionality of the receiving equipment combined with the viewer's preferences). In this example, the functionality provided by the AFD is analogous to (but different from) that provided by Wide Screen Signalling (WSS) described in EN 300 294 [14].

In addition, the AFD extends WSS by allowing the "area of interest" of a full-frame 16:9 (anamorphic) image to be described, for example to indicate that the centre 4:3 portion of the image has been protected such that a set-top box connected to a 4:3 set may perform a centre cut-out without removing any essential picture information.

The AFD itself does not describe the aspect ratio of the coded frame (as this is described elsewhere in the MPEG-2, H264/AVC, or SMPTE VC-1 video syntax).

B.3.1 Coded Frame in MPEG-2 Video

The **active_format** is used by the decoder in conjunction with the "source aspect ratio". The source aspect ratio is derived from the "display aspect ratio"(DAR) signalled in the **aspect_ratio_information**, the **horizontal_size**, **vertical_size**, and **display_horizontal_size** and **display_vertical_size** if present (see ITU-T Recommendation H.262 | ISO/IEC 13818-2 [2]):

- If **sequence_display_extension()** is not present:

$$\text{source aspect ratio} = \text{DAR}$$

- If **sequence_display_extension()** is present:

$$\text{source aspect ratio} = \text{DAR} \times \frac{\text{display_horizontal_size}}{\text{display_vertical_size}} \times \frac{\text{vertical_size}}{\text{horizontal_size}}$$

B.3.2 Coded Frame in H264/AVC Video

The `active_format` is used by the receiver in conjunction with picture size and shape information as indicated in the “sequence parameter set Rbsp” and the `aspect_ratio_idc` field of the “VUI parameters”. In particular, the picture width, picture height, frame cropping information, and sample aspect ratio are important for proper use of `active_format`. (see ISO/IEC 14496-10 [16]):

The combination of source aspect ratio and `active_format` allows the receiver to identify whether the “area of interest” is the whole of the frame (e.g., source aspect ratio 16:9, `active_format` 16:9 center), a letterbox within the frame (e.g., source aspect ratio 4:3, `active_format` 16:9 center), or a “pillarbox” within the frame (e.g., source aspect ratio 16:9, `active_format` 4:3 center).

B.3.3 Coded Frame in VC-1 Video

The `active_format` is used by the decoder in conjunction with the sample aspect ratio signalled in a VC-1 elementary stream by means of the `ASPECT_RATIO` field in the sequence header as defined in SMPTE 421M [21].

The combination of sample aspect ratio and `active_format` allows the decoder to identify whether the “area of interest” is the whole of the frame (e.g. source aspect ratio 16:9, `active_format` 16:9 centre), a letterbox within the frame (e.g. source aspect ratio 4:3, `active_format` 16:9 centre), or a “pillar-box” within the frame (e.g. source aspect ratio 16:9, `active_format` 4:3 centre).

B.3.4 Common Semantics of AFD

The combination of source aspect ratio and `active_format` allows the decoder to identify whether the “area of interest” is the whole of the frame (e.g. source aspect ratio 16:9, `active_format` 16:9 centre), a letterbox within the frame (e.g. source aspect ratio 4:3, `active_format` 16:9 centre), or a “pillar-box” (see NOTE) within the frame (e.g. source aspect ratio 16:9, `active_format` 4:3 centre).

NOTE: “Pillar-box” describes a frame that the image fails to fill horizontally, in the same way that a “Letterbox” describes a frame that the image fails to fill vertically.

Table B.5: active_format

Active_format	Aspect ratio of the "area of interest"
0000	AFD unknown (see below)
0001	Reserved
0010	box 16:9 (top)
0011	box 14:9 (top)
0100	box > 16:9 (centre)
0101 – 0111	Reserved
1000	Active format is the same as the coded frame
1001	4:3 (centre)
1010	16:9 (centre)
1011	14:9 (centre)
1100	Reserved
1101	4:3 (with shoot & protect 14:9 centre)
1110	16:9 (with shoot & protect 14:9 centre)
1111	16:9 (with shoot & protect 4:3 centre)

AFD 0000 indicates that information is not available and is undefined. Unless bar data is available, DTV receivers and video equipment should interpret the active format as being the same as the coded frame. AFD ‘0000’, when accompanied by bar data, signals that the image’s aspect ratio is narrower than 16:9, but is not either 4:3 or 14:9. The bar data should be used to determine the extent of the image.

AFD ‘0100’, which should be accompanied by bar data, signals that the image’s aspect ratio is wider than 16:9, as is typically the case with widescreen features. The bar data should be used to determine the height of the image.

The complete set of Active Formats described in the present document is illustrated in Table B.6. Note that for each format two example illustrations have been given, corresponding to the source aspect ratio of the coded frame being 4:3 and 16:9. The AFD may also be used with coded frames of other aspect ratios. For example a coded frame of 2.21:1 with active_format 10 would represent a 16:9 image centred (pillar-box) within a 2.21:1 frame.

The Active Formats are illustrated using the following diagrammatic representation.

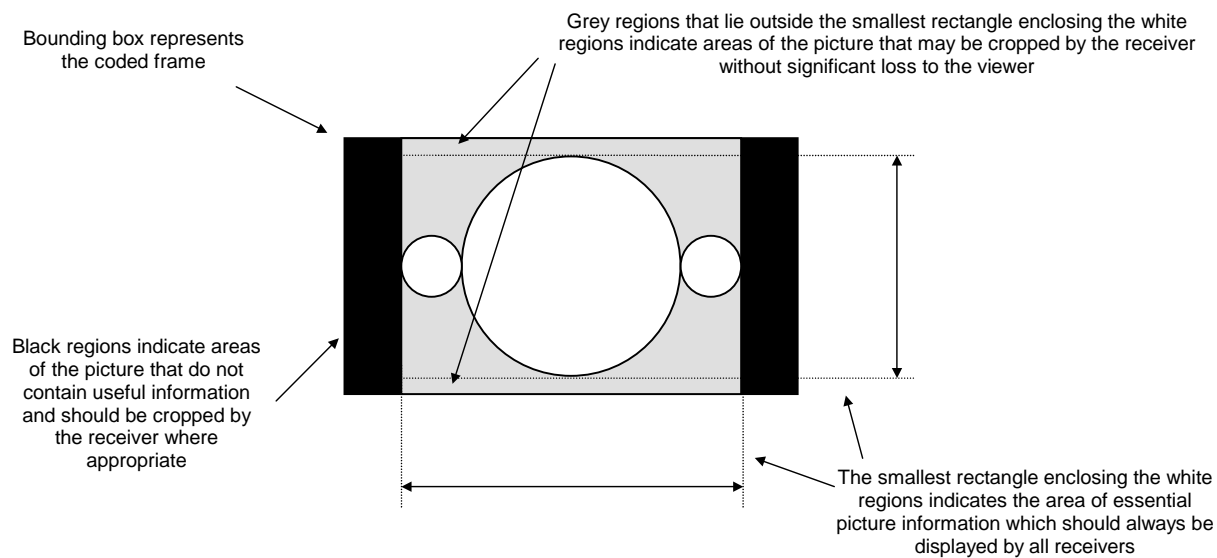
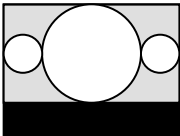
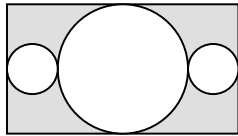
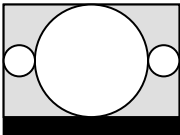
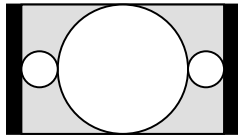
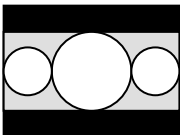
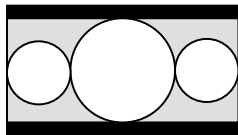
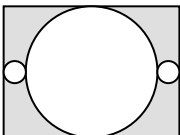
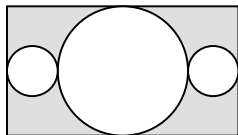
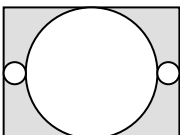
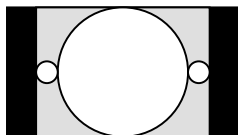
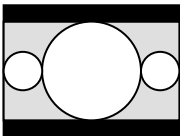
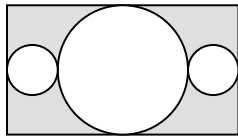
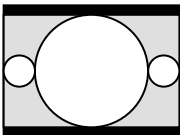
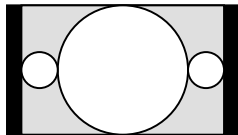
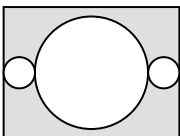
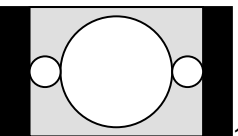
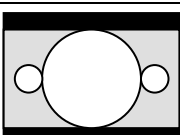
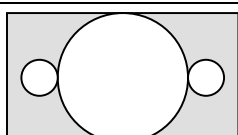
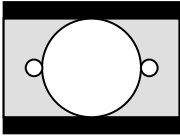
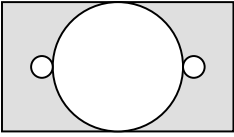

Figure B.1

Table B.6: Active Formats Illustrated

Active_format		Illustration of described format	
value	description	in 4:3 coded frame	in 16:9 coded frame
0000 - 0001	reserved		
0010	box 16:9 (top)		
0011	box 14:9 (top)		
0100	box > 16:9 (centre)		
0101 - 0111	reserved		
1000	As the coded frame		
1001	4:3 (centre)		 (see note)
1010	16:9 (centre)		
1011	14:9 (centre)		
1100	reserved		
1101	4:3 (with shoot & protect 14:9 centre)		 ₁
1110	16:9 (with shoot & protect 14:9 centre)		

Active_format		Illustration of described format	
value	description	in 4:3 coded frame	in 16:9 coded frame
1111	16:9 (with shoot & protect 4:3 centre)		
NOTE: It is recommended to use the 4:3 coded frame mode to transmit 4:3 source material rather than using a pillar box to transmit it in a 16:9 coded frame. This allows for higher horizontal resolution on both 4:3 and 16:9 sets.			

B.3.5 Relationship with Pan Vectors

Encoding: Encoded bit-streams may optionally include pan vectors and AFDs.

Decoding: The decoder may use the AFD as part of the logic that decides how the IRD processes and positions the reconstructed image for display on a monitor, where the monitor aspect ratio does not match the source aspect ratio (e.g. whether to use pan vectors, or generate a letterbox display).

B.4 Bar data

Table B.7 describes the syntax of bar data. Bar data should be included in video user data whenever the rectangular picture area containing useful information does not extend to the full height or width of the coded frame and AFD alone is insufficient to describe the extent of the image. See clause B.3.4 of this Annex..

Bar data is constrained (below) to be signalled in pairs, either top and bottom bars or left and right bars, but not both pairs at once. Bars may be unequal in size. One bar of a pair may be zero width or height.

Table B.7: Bar Data Syntax

Syntax	No. of Bits	Identifier
bar_data() {		
top_bar_flag	1	bslbf
bottom_bar_flag	1	bslbf
left_bar_flag	1	bslbf
right_bar_flag	1	bslbf
reserved (set to '1111')	4	bslbf
if (top_bar_flag == '1') {		
marker_bits (set to '11')	2	bslbf
line_number_end_of_top_bar	14	uimsbf
}		
if (bottom_bar_flag == '1') {		
marker_bits (set to '11')	2	bslbf
line_number_start_of_bottom_bar	14	uimsbf
}		
if (left_bar_flag == '1') {		
marker_bits (set to '11')	2	bslbf
pixel_number_end_of_left_bar	14	uimsbf
}		
if (right_bar_flag == '1') {		
marker_bits (set to '11')	2	bslbf
pixel_number_start_of_right_bar	14	uimsbf
}		
}		

Designation of line numbers for line_number_end_of_top_bar and line_number_start_of_bottom_bar is video format-dependent and shall conform to the applicable standard indicated in Table B.8.

Note: The range of line numbers and pixels within the coded frame for each image format is specified in Table 2 of SMPTE 2016-1 [25].

Table B.8: Line Number Designation

Video Format	Applicable Standard
480 Interlaced 4:3	SMPTE 125M
480 Interlaced 16:9	SMPTE 267M
480 Progressive	SMPTE 293M
720 Progressive	SMPTE 296M
1080 Interlaced	SMPTE 274M
1080 Progressive	SMPTE 274M

top_bar_flag: This flag shall indicate, when set to '1', that the top bar data is present. If left_bar_flag is '1', this flag shall be set to '0'.

bottom_bar_flag: This flag shall indicate, when set to '1', that the bottom bar data is present. This flag shall have the same value as top_bar_flag.

left_bar_flag: This flag shall indicate, when set to '1', that the left bar data is present. If top_bar_flag is '1', this flag shall be set to '0'.

right_bar_flag: This flag shall indicate, when set to '1', that the right bar data is present. This flag shall have the same value as left_bar_flag.

line_number_end_of_top_bar: A 14-bit unsigned integer value representing the last line of a horizontal letterbox bar area at the top of the reconstructed frame. Designation of line numbers shall be as defined per each applicable standard in Table B.8.

line_number_start_of_bottom_bar: A 14-bit unsigned integer value representing the first line of a horizontal letterbox bar area at the bottom of the reconstructed frame. Designation of line numbers shall be as defined per each applicable standard in Table B.8.

pixel_number_end_of_left_bar: A 14-bit unsigned integer value representing the last horizontal luminance sample of a vertical pillarbox bar area at the left side of the reconstructed frame. Pixels shall be numbered from zero, starting with the leftmost pixel.

pixel_number_start_of_right_bar: A 14-bit unsigned integer value representing the first horizontal luminance sample of a vertical pillarbox bar area at the right side of the reconstructed frame. Pixels shall be numbered from zero, starting with the leftmost pixel.

additional_bar_data: Reserved for future DVB definition.

B.4.1 Recommended Receiver Response to Bar Data

Receiving device designers are strongly encouraged to study Consumer Electronics Association (CEA) bulletin CEB16 [26], which contains recommendations regarding the processing of bar data.

B.4.2 Relationship Between Bar Data and AFD

Certain combination of Active Format Description and bar data may be present in video user data (either, neither, or both). Note that AFD data may not always exactly match bar data because AFD only deals with 4:3, 14:9, and 16:9 aspect ratios while bar data can represent nearly any aspect ratio. When AFD and bar data are present together, AFD should be used in preference to bar data, except in the cases of AFD '0000' and '0100', where bar data should be used in concert with AFD as described above.

B.5 Closed Captions

The caption data, (as well as AFD and bar data) is carried in the user data of the video elementary stream.

The underlying structure, `cc_data()`, is common across MPEG-2, H.264/AVC, and VC-1.

B.5.1 Syntax and Semantics of `cc_data()`

The syntax for `cc_data()` is shown in Table B.9.

Table B.9: `cc_data` Syntax

Syntax	No. of Bits	Identifier
<code>cc_data() {</code>		
reserved (set to '1')	1	bslbf
process_cc_data_flag	1	bslbf
zero_bit (set to '0')	1	bslbf
cc_count	5	uimsbf
reserved (set to '1111 1111')	8	bslbf
for (i=0 ; i < cc_count ; i++) {		
one_bit (set to '1')	1	
reserved (set to '1111')	4	
cc_valid	1	bslbf
cc_type	2	bslbf
cc_data_1	8	bslbf
cc_data_2	8	bslbf
}		
marker_bits = '11111111'	8	bslbf
}		

process_cc_data_flag: This flag is set to indicate whether it is necessary to process the `cc_data`. If it is set to '1', the `cc_data` shall be parsed and its meaning processed. When it is set to '0', the `cc_data` shall be discarded.

zero_bit: This bit shall be '0' to maintain backwards compatibility with previous versions of CEA-708-C [28].

cc_count: This 5-bit integer indicates the number of closed caption constructs following this field. It can have values 0 through 31. The value of `cc_count` shall be set according to the frame rate and coded picture structure (field or frame) such that a fixed bandwidth of 9600 bits per second is maintained for the closed caption payload data. Sixteen (16) bits of closed caption payload data are carried in each pair of the fields `cc_data_1` and `cc_data_2`.

one_bit: This bit shall be '1' to maintain backwards compatibility with previous versions of CEA-708-C [28].

cc_valid: This flag is set to '1' to indicate that the two closed caption data bytes that follow are valid. If set to '0' the two data bytes are invalid, as defined in CEA-708-C [28].

cc_type: Denotes the type of the two closed caption data bytes that follow, as defined in CEA-708-C [28].

cc_data_1: The first byte of a closed caption data pair as defined in CEA-708-C [28].

cc_data_2: The second byte of a closed caption data pair as defined in CEA-708-C [28].

B.6 Auxiliary Data and MPEG-2 video

B.6.1 Coding

The Auxiliary Data (AFD, bar data, and caption data) is carried in the video elementary stream at the picture level as shown in Table B.10. The repetition rate of the Auxiliary Data depends upon its payload.

When present, caption data shall be carried in the data structure **cc_data()**, within the picture user data syntax as shown in Table B.9, and shall be present for every picture. Receivers may ignore caption data.

When present, bar data shall be carried in the data structure **bar_data()**, within the picture user data syntax as shown in Table B.7. After any **sequence_header()** such bar data shall appear before the next **picture_data()** within **extension_and_user_data(2)**. After introduction, such bar data shall remain in effect until:

1. the next **sequence_header()**, or
2. **extension_and_user_data(2)** containing a **bar_data()** structure which contains new bar data, or
3. **extension_and_user_data(2)** containing AFD per Section B.3.4.

After any **sequence_header()**, unless AFD data is present specifying otherwise, the absence of bar data shall indicate that the rectangular picture area containing useful information extends to the full height and width of the coded frame.

B.6.2 Syntax and Semantics

Table B.10 is provided to show the syntax that is required for picture extension and user data (specifically **extension_and_user_data(2)**) as defined by MPEG-2 video (ISO/IEC 13818-2 [2]).

Table B.10: Auxiliary Data for MPEG-2 video

Syntax	No. of Bits	Identifier
user_data() {		
user_data_start_code	32	bslbf
user_identifier	32	bslbf
user_structure()		
}		

In accordance with the bit stream syntax in Table B.10, more than one picture user data construct may follow any given picture header. However, no more than one picture user data construct using the same **user_identifier** or **user_data_type_code** shall follow any given picture header.

Receiving devices are expected to silently discard any unrecognized video user data encountered in the video bit stream. For example, if an unrecognized 32-bit identifier is seen following the **user_data_start_code**, or an unrecognized 8-bit **user_data_type_code** is seen following the **DVB_identifier**, data should be discarded until another start code is seen.

user_data_start_code: This shall be set to 0x0000 01B2 per ISO/IEC 13818-2 [2].

user_identifier: This is a 32 bit code that indicates the contents of the **user_structure()** as indicated in Table B.1.

user_structure(): This is a variable length data structure defined by the value of **user_identifier** and Table B.1.

B.7 Auxiliary Data and H264/AVC video

B.7.1 Coding

The Auxiliary Data is carried in the data as Supplemental Enhancement Information in H.264/AVC's "User data registered by ITU-T Recommendation T.35 [20] SEI message" syntactic element (See clauses D.8.5 and D.9.5 of ISO/IEC 14496-10 [16]).

Encoding: Support for the encoding of Auxiliary Data is optional.

Decoding: Support for the decoding of Auxiliary Data is optional.

B.7.2 Syntax and Semantics

The Auxiliary Data (AFD, bar data, and caption data) is carried in the video elementary stream as Supplemental Enhancement Information in H.264/AVC's "User data registered by ITU-T Recommendation T.35 SEI message" syntactic element [20]. The syntax of Auxiliary Data is illustrated in Table B.11.

Table B.11: Active Format Description for H264/AVC video

<code>user_data_registered_itu_t_t35(payloadSize) {</code>	Descriptor	Notes
<code> itu_t_t35_country_code</code>	b(8)	0xB5
<code> itu_t_t35_provider_code</code>	u(16)	0x0031
<code> user_identifier</code>	f(32)	
<code> user_structure()</code>		
<code>}</code>		

itu_t_t35_country_code: this 8 bit field shall have the value 0xB5.

itu_t_t35_provider_code: this 16 bit field shall have the value 0x0031.

user_identifier: This is a 32 bit code that indicates the contents of the **user_structure()** as indicated in Table B.1.

NOTE: In MPEG-2, the only discriminator within **user_data** is this 32-bit value. In the context of H.264/AVC, the value of **user_identifier** is used in addition to country and provider codes to definitively identify this as Auxiliary Data.

user_structure(): This is a variable length data structure defined by the value of **user_identifier** and Table B.1.

B.8 Auxiliary Data and VC-1 video

B.8.1 Coding

The Auxiliary Data is carried in the user data of the video elementary stream as defined in SMPTE 421M [21]. After each sequence start (and repeat sequence start) the default aspect ratio of the area of interest is that signalled by the sequence header and sequence display extension parameters. When present, after introduction, an AFD or bar data persists until the next sequence start or until another AFD or different bar data is introduced.

Encoding: Support for the encoding of Auxiliary Data is optional.

The Auxiliary Data may be inserted in the video elementary stream as sequence level, entry-point level or frame level user data as specified in SMPTE 421M [21]. For example, it could be inserted once per sequence, once per entry-point, or once per frame. It may be changed for each frame. Caption data, when present, shall be inserted once per frame.

After introduction, such an AFD remains in effect until the next sequence start or until a new AFD is introduced.

Decoding: Support for the decoding of Auxiliary Data is optional.

A decoder that supports the decoding of Auxiliary Data shall be capable of decoding it from the sequence level, entry-point level and frame level locations specified in SMPTE 421M [21].

B.8.2 Syntax and Semantics

The Auxiliary Data is carried in the user data of the video elementary stream as defined in SMPTE 421M [21]. The syntax is illustrated in Table B.12.

Table B.12: Auxiliary Data for VC-1 video

Syntax	No. of Bits	Identifier
user_data() {		
VC1_user_data_start_code	32	bslbf
user_identifier	32	bslbf
user_structure()		
}		

VC1_user_data_start_code: This 32-bit field shall be set to 0x0000011D to indicate the beginning of a user data structure in the VC-1 elementary stream.

user_identifier: This is a 32 bit code that indicates the contents of the **user_structure()** as indicated in Table B.1.

user_structure(): This is a variable length data structure defined by the value of **user_identifier** and Table B.1.

B.9 Relationship with Wide Screen Signalling (WSS)

The AFD and bar data provide a super-set of the aspect ratio signalling specified in EN 300 294 [14]. The mapping of source aspect ratio and active_format to WSS Aspect Ratio is given in Table B.13.

Table B.13: Support for WSS

Sequence Header	Active Format Description	WSS	
source aspect ratio	value	code (bits 0-3)	description
	1001	0001	full format 4:3
	1011	1000	box 14:9 Centre
	0011	0100	box 14:9 Top
4:3	1010	1101	box 16:9 Centre
	0010	0010	box 16:9 Top
	0100	1011	box > 16:9 Centre
	1101	0111	full format 4:3 (shoot and protect 14:9 Centre)
16:9	1010	1110	full format 16:9 (anamorphic)

As all-digital systems are constructed, there may remain legacy (or even regulatory) requirements to provide WSS support at some IRD outputs. It is recommended that transmission systems make use of SMPTE 2016-1 [25] for signalling AFD and bar data in the incoming video, and that IRDs provide support for this on digital outputs.

Encoding: Incoming aspect ratio signalling (whether originating via WSS or AFD) should be placed in the video elementary stream per this document. If desired, the encoder may also carry equivalent WSS data per EN 300 294 [14] in a separate PID.

Decoding: IRDs shall pass AFD and bar data values to their digital video outputs. Such values may be translated, per Table B.13 into analog WSS waveforms for appropriate placement on analog outputs.

B.10 Aspect Ratio Ranges

The labels 4:3, 14:9, 16:9 and > 16:9 used in the AFD shall correspond to the aspect ratio ranges specified in EN 300 294 [14]. (Note that the corresponding active lines specified in EN 300 294 [14] do not, in general, apply.)

Annex C (informative): Implementation of Ancillary Data for MPEG Audio

C.1 Scope

This annex contains the guidelines required to include ancillary data in the MPEG Audio elementary stream.

The IRD design should be made under the assumption that any structure as permitted by this annex may occur in the broadcast stream. The IRD is not required to make use of this data but its use is recommended.

C.2 Introduction

An MPEG audio elementary stream provides for the inclusion of ancillary data. This data can be used to convey specific information about the audio content to the decoder, allowing the broadcaster to control rendering of the content to a greater extent. The data includes dynamic range control information and dialogue normalization information.

In case of MPEG1 streams or MPEG2 streams without an extension stream (MPEG audio format 1), ancillary data described in this annex is placed at the end of each base frame.

In case of MPEG2 streams with extension stream (MPEG audio format 2), the ancillary data described in this annex is placed at the end of each base frame.

In case of MPEG4 streams in LATM/LOAS format, the ancillary data described in this annex is placed into `data_stream_element()` (see ISO/IEC 14496-3 [17], table 4.10).

C.3 DVB Compliance

The ancillary data format described in this annex does not introduce any additional elements to the DVB transport stream. It is compliant with the current specification and compatible with all MPEG audio decoders.

Presence and type of ancillary data in audio elementary streams is signalled in DVB SI Program Map Table by the "Ancillary data descriptor" (see EN 300 468 [6], clause 6.2.2).

C.4 Detailed specification for MPEG1 and MPEG2

C.4.1 DVD-Video Ancillary Data

The transmission of "dynamic_range_control" in MPEG1 Layer I/II and MPEG2 Layer I audio is optional. *If applied, 16 bits of ancillary data [b15.b0] (situated at the end of each MPEG audio base frame) shall be used.*

Table C.1: DVD-Video ancillary data syntax

Syntax	No. of bits	Mnemonic
<code>dvd_ancillary_data() {</code>		
dynamic_range_control	8	bslbf
dynamic_range_control_on	1	bslbf
reserved (set to "000 0000b")	7	bslbf
<code>}</code>		

Semantics: The 8-bit dynamic_range_control field leads to the following gain control value by considering the upper 3 bits as unsigned integer X and the binary value of the lower 5 bits as unsigned integer Y:

- linear: $G = 2^{4-(X + Y/30)}$

$$(0 \leq X \leq 7, 0 \leq Y \leq 29)$$

- in dB: $G = 24.082 - 6.0206 X - 0.2007 Y$

$$(0 \leq X \leq 7, 0 \leq Y \leq 29)$$

If the `dynamic_range_control_on` field is set to "0b", the `dynamic_range_control` field does not convey useful information.

Encoding: *When dynamic range control is temporarily not applied, that value of `dynamic_range_control` shall be set to "1000 0000b" or `dynamic_range_control_on` shall be set to "0b".*

Decoding: *The decoder shall read this field, and the decoder shall interpret the value G as a gain value applied to all sub band samples, before the reconstruction filter. This value may be scaled in the decoder to allow user control of the amount of dynamic range compression that is applied.*

C.4.2 Extended ancillary data syntax

The syntax of the extended ancillary data field is described in Table C.2.

The extended ancillary data is inserted beginning from the end of the base frame. It is recommended that it be parsed from the end. The description in Table C.2 is in the reverse order of the transmission. The bit order in each byte is, however, such that the msb comes first in the transmission.

Table C.2: Extended ancillary data syntax

Syntax	No. of bits	Mnemonic
extended_ancillary_data() {		
dvd_ancillary_data	16	bslfb
extended_ancillary_data_sync (set to 0xBC)	8	bslfb
bs_info	8	bslbf
ancillary_data_status	8	bslbf
if(advanced_dynamic_range_control_status == 1)		
advanced_dynamic_range_control	24	bslbf
if(dialog_normalization_status == 1)		
dialog_normalization	8	bslbf
if(reproduction_level_status == 1)		
reproduction_level	8	bslbf
if(downmixing_levels_MPEG2_status == 1)		
downmixing_levels_MPEG2	8	bslbf
if(audio_coding_mode_and_compression_status == 1) {		
audio_coding_mode	8	bslbf
Compression	8	bslbf
}		
if(coarse_grain_timecode_status == 1)		
coarse_grain_timecode	16	bslbf
if(fine_grain_timecode_status == 1)		
fine_grain_timecode	16	bslbf
if(scale_factor_CRC_status == 1)		
scale_factor_CRC	16 - 32	bslbf
}		

The elements of the ancillary data structure are described in the following clauses. The order of the bits is in transmission order, msb first.

C.4.2.1 ancillary_data_sync

Encoding: *This field shall be set to 0xBC.*

Decoding: The decoder may use this field to verify the availability of the extended ancillary data. If the IRD indicates that this information is present, this takes precedence.

C.4.2.2 bs_info

The detailed syntax is described in Table C.3.

Table C.3: bs_info syntax

Syntax	No. of bits	Mnemonic
bs_info() {		
mpeg_audio_type	2	bslbf
dolby_surround_mode	2	bslbf
ancillary_data_bytes	4	uimsbf
}		

C.4.2.3 mpeg_audio_type

Table C.4: MPEG audio type Table

mpeg_audio_type	Description
"00"	Reserved
"01"	Only MPEG1 audio data
"10"	MPEG2 audio data
"11"	Reserved

Decoding: The decoder may ignore this field.

C.4.2.4 dolby_surround_mode

Table C.5: Dolby surround mode Table

mpeg_audio_type	Description
"00"	Reserved
"01"	MPEG1 part is not Dolby surround encoded
"10"	MPEG1 part is Dolby surround encoded
"11"	Reserved

Decoding: It is recommended that the decoder parse this field and provides this information to the reproduction set-up.

C.4.2.5 ancillary_data_bytes

This field indicates the amount of ancillary data bytes that precede this byte in the transmission. This field may be used by the decoder as an indication of how many bytes it needs to buffer.

C.4.2.6 ancillary_data_status

The detailed syntax is described on Table C.6.

Table C.6: ancillary_data_status syntax

Syntax	No. of bits	Mnemonic
ancillary_data_status() {		
advanced_dynamic_range_control_status	1	bslbf
dialog_normalization_status	1	bslbf
reproduction_level_status	1	bslbf
downmix_levels_MPEG2_status	1	bslbf
scale_factor_CRC_status	1	bslbf
audio_coding_mode_and_compression_status	1	bslbf
coarse_grain_timecode_status	1	bslbf
fine_grain_timecode_status	1	bslbf
}		

Semantics: The bits in this field indicate the presence of the associated fields in the ancillary data.

Encoding: *A bit in this field shall be set to "1" if the associated field is present in the bitstream.*

Decoding: It is recommended that the decoder parse this field to allow parsing of the following fields in the ancillary data section.

C.4.2.7 advanced_dynamic_range_control

The detailed syntax is described on Table C.7.

Table C.7: advanced_dynamic_range_control syntax

Syntax	No. of bits	Mnemonic
advanced_dynamic_range_control() {		
advanced_drc_part_0	8	bslbf
advanced_drc_part_1	8	bslbf
advanced_drc_part_2	8	bslbf
}		

Semantics: Each field consists of an unsigned integer value X in the three msb's and an unsigned integer value Y in the five lsb's. The actual value is $24.082 - 6.0206 X - 0.2007 Y$ dB. The 1152 samples of an MPEG2 frame are divided in 3 parts of 384 samples. The advanced_drc values are applicable for the corresponding part of the audio frame.

Decoding: *If this field is present and the decoder supports this type of dynamic range control, these values shall be used rather than the DVD-Video ancillary data. The decoder shall apply these values to the sub band samples, before the reconstruction filter. These values may be scaled in the decoder to allow user control of the amount of dynamic range compression that is applied.*

C.4.2.8 dialog_normalization

The detailed syntax is described on Table C.8.

Table C.8: dialog_normalization syntax

Syntax	No. of bits	Mnemonic
dialog_normalization() {		
dialog_normalization_on	2	bslbf
dialog_normalization_value	6	uimsbf
}		

C.4.2.8.1 dialog_normalization_on

Table C.9: Dialog normalization Table

dialog_normalization_on	Description
"00"	dialog_normalization_value is not valid
"01"	reserved
"10"	dialog_normalization_value is valid
"11"	Reserved

C.4.2.8.2 dialog_normalization_value

Semantics: This field represents the headroom in dB of the dialogue component in the MPEG1 compatible part, relative to full-scale sine wave. Values 41 through 63 are reserved. *When dialogue normalization is temporarily not applied, "Dialogue_Normalization_on" shall be set to "00" and "Dialog_Normalization_value" shall be set to "000000".*

Decoding: It is recommended that the decoder parse this field. The decoder should apply these values to the sub band samples, before the reconstruction filter, in order to allow reproduction of different programmes with the same dialogue level.

C.4.2.9 reproduction_level

The detailed syntax is described on Table C.10.

Table C.10: reproduction_level syntax

Syntax	No. of bits	Mnemonic
reproduction_level () {		
Surround_reproduction_level	1	bslbf
production_roomtype	2	bslbf
reproduction_level_value	5	uimsbf
}		

C.4.2.9.1 surround_reproduction_level

Table C. 11: Surround reproduction level Table

surround_reproduction_level	Description
"0"	The surround channels have the correct level for reproduction
"1"	The surround channels should be attenuated by 3 dB during reproduction

Decoding: It is recommended that the decoder parse this field and pass the value to the reproduction unit to allow correct adjustment of the surround levels.

C.4.2.9.2 production_roomtype

Table C. 12: Production room type Table

production_roomtype	Description
"00"	not indicated
"01"	large room
"10"	small room
"11"	reserved

Decoding: It is recommended that the decoder parse this field and pass the value to the reproduction unit to allow correct adjustment of the monitoring equipment.

C.4.2.9.3 reproduction_level_value

Semantics: This field represents the absolute acoustic sound pressure level in dB SPL during the final audio mixing session.

Decoding: The decoder may ignore this field.

C.4.2.10 downmixing_levels_MPEG2

The detailed syntax is described on Table C.13. The down mixing levels describe the down mix in the decoder for stereo reproduction.

Table C.13: downmixing_levels_MPEG2 syntax

Syntax	No. of bits	Mnemonic
downmixing_levels_MPEG2 () {		
center_mix_level_on	1	bslbf
center_mix_level_value	3	bslbf
Surround_mix_level_on	1	bslbf
Surround_mix_level_value	3	bslbf
}		

C.4.2.10.1 center_mix_level_on

Semantics: If this field is set to "1" the center_mix_value field indicates nominal down mix level of the centre channel with respect to the left and right front channels. *If this field is set to "0" the center_mix_value field shall be set to "000".*

Decoding: It is recommended that the decoder parse this field.

C.4.2.10.2 surround_mix_level_on

Semantics: If this field is set to "1" the surround_mix_value field indicates nominal down mix level of the surround channels with respect to the left and right front channels. *If this field is set to "0" the surround_mix_value field shall be set to "000".*

Decoding: It is recommended that the decoder parse this field.

C.4.2.10.3 mix_level_value

Table C.14: Mix level value Table

mix_level_value	Multiplication factor
"000"	1.000 (0.0 dB)
"001"	0.841 (-1.5 dB)
"010"	0.707 (-3.0 dB)
"011"	0.596 (-4.5 dB)
"100"	0.500 (-6.0 dB)
"101"	0.422 (-7.5 dB)
"110"	0.355 (-9.0 dB)
"111"	0.000 ($-\infty$ dB)

Decoding: The multi-channel decoder may apply these values as gain factors to the individual channels when a down mix for stereo listening has to be created. The values need to be scaled to avoid overload after the mixing process.

C.4.2.11 audio_coding_mode

The detailed syntax is described in Table C.15.

Table C.15: audio coding mode syntax

Syntax	No. of bits	Mnemonic
audio_coding_mode () {		
MPEG2_extension_stream_present	1	bslbf
MPEG2_center	2	bslbf
MPEG2_surround	2	bslbf
MPEG2_lfeon	1	bslbf
MPEG2_copyright_ident_present	1	bslbf
compression_on	1	bslbf
}		

Semantics: The semantics of the fields MPEG2_extension_stream_present, MPEG2_center, MPEG2_surround and MPEG2_lfeon is as defined in the mc_header field in [3].

If MPEG2_copyright_ident_present is set to "0" the copyright identification in the MPEG 2 mc_header is not filled in. If MPEG2_copyright_ident_present is set to "1" the copyright identification in the MPEG 2 mc_header is used.

Decoding: The decoder may ignore this field. It may be parsed by multiplexers and bitstream monitors to simplify extraction of these parameters from a bitstream.

C.4.2.11.1 compression_on

Semantics: If this field is set to "1" the compression_value field indicates the heavy compression factor used for monophonic down mix reproduction. *If this field is set to "0" the compression_value field shall be "0000 0000".*

Decoding: It is recommended that the decoder parse this field.

C.4.2.12 compression_value

Semantics: This field consists of a value X in the four msb's and a value Y in the four lsb's. The actual value is $48.164 - 6.0206 X - 0.4014 Y$ dB.

Decoding: *These values shall be applied to the sub band samples, before the reconstruction filter when the decoder has to create a mix for monophonic listening where overloading of a subsequent analog transmission is highly undesirable.*

C.4.2.13 coarse_grain_timecode

The detailed syntax is described on Table C.16.

Table C.16: coarse grain time code syntax

Syntax	No. of bits	Mnemonic
coarse_grain_timecode () {		
coarse_grain_timecode_on	2	bslbf
coarse_grain_timecode_value	14	bslbf
}		

Semantics: If coarse_grain_timecode_on is set to "10" the five msb's of this value represents the time in hours, the next six bits represent time in minutes, and the final three bits represent the time in eight second increments. *If coarse_grain_timecode_on is not set to "10" all the bits of coarse_grain_timecode_value shall be set to "0".*

Decoding: The decoder may ignore this field.

C.4.2.14 fine_grain_timecode

The detailed syntax is described in Table C.17.

Table C.17: fine grain time code syntax

Syntax	No. of bits	Mnemonic
fine_grain_timecode () {		
fine_grain_timecode_on	2	bslbf
fine_grain_timecode_value	14	bslbf
}		

Semantics: If fine_grain_timecode_on is set to "10" the three msb's of this value represents the time in seconds, the next five bits represent time in video frames, and the final six bits represent the time in fractions of 1/64 of a video frame. *If fine_grain_timecode_on is not set to "10" all the bits of fine_grain_timecode_value shall be set to "0".*

Decoding: The decoder may ignore this field.

C.4.2.15 scale_factor_CRC

Semantics: The scale_factor_CRC permits to verify the integrity of the MPEG Audio scale factors. The coding is according to [20].

Encoding: It recommended that scale_factor_CRC be included for mobile applications.

Decoding: It is recommended to parse the data from the end. The length of the field depends on the bit rate index of the MPEG 1 header of the following frame. It is recommended to always parse the full 32 possible bits.

C.4.2.16 Announcement Switching Data

The transmission of announcement switching data in the ancillary data field of MPEG audio frames is optional. The syntax of the announcement switching data field is described in Table C.18. Note that the description in Table C.18 is in the reverse order of the transmission. The bit order in each byte is, however, such that the msb comes first in the transmission. The data field length gives the number of bytes following this byte within this data field.

Table C.18: Announcement switching data field

Syntax	No. of bits	Mnemonic
announcement_switching_data() {		
announcement_switching_data_sync	8	bslbf
data_field_length	8	bslbf
announcement_switching_flag_field_1	16	bslbf
announcement_switching_flag_field_2	16	bslbf
}		

Semantics: The announcement_switching_data_sync should be set to 0 x AD.

The announcement_switching_flag_fields are 16-bit flag fields specifying which type of announcements are actually running. *The association between the bits of the flag field and the announcement types shall be according to the announcement_support_indicator [6]. A bit shall be set to "1" if the announcement is running and it shall be set to "0" if the announcement is not running.*

The announcement_switching_flag_field_1 shall be used for announcements within the audio elementary stream that is actually decoded.

The announcement_switching_flag_field_2 shall be used for announcements within other audio elementary streams. Corresponding links shall be provided by means of the announcement_support_descriptor [6].

Encoding: The `announcement_switching_data_field` is allowed to be embedded at the end of a MPEG audio packet, between the end of the audio data and another data field that is part of the ancillary data field or between two other data fields that are part of the ancillary data field.

If data fields according to DVD-Video, extended ancillary data or ancillary data according to the DAB specification [19] are used, then the `announcement_switching_data_field` is not allowed to be inserted at the end of an audio packet.

Decoding: It is recommended to parse the data from the end.

C.4.2.17 Scale Factor Error Check

The transmission of a scale factor error check in the ancillary data field of MPEG audio frames is optional. The syntax of the corresponding data field is described in Table C.19. Note that the description in Table C.19 is in the reverse order of the transmission. The bit order in each byte is, however, such that the msb comes first in the transmission. The `data_field_length` gives the number of bytes following this byte within this data field.

Table C.19: Scale factor error check data field

Syntax	No. of bits	Mnemonic
<code>scale_factor_error_check_data() {</code>		
<code>scale_factor_error_check_data_sync</code>	8	Bslbf
<code>data_field_length</code>	8	Bslbf
<code>scale factor CRC</code>	32	Bslbf
<code>}</code>		

Semantics: The `scale_factor_error_check_data_sync` should be set to 0 x FE.

The `scale_factor CRC` permits to verify the integrity of the MPEG Audio scale factors.

Encoding: The `scale_factor_error_check` is allowed to be embedded at the end of a MPEG audio packet, between the end of the audio packet and another data field that is part of the ancillary data field or between two other data fields that are part of the ancillary data field.

If data fields according to DVD-Video extended ancillary data (as described in clause C.4.1) or ancillary data according to the DAB specification EN 300 401[19] are used, then the `scale_factor_error_check_data_field` is not allowed to be inserted at the end of an audio packet.

Decoding: It is recommended to parse the data from the end.

C.4.2.18 RDS data via UECP protocol

The transmission of RDS data via the UECP protocol [24] in the ancillary data field of MPEG audio frames is optional. The syntax of the UECP data field is described in Table C.20. Note that the description in Table C.20 is in the reverse order of the transmission. The bit order in each byte is, however, such that the msb comes first in the transmission. The `data field length` gives the number of bytes following this byte within this data field.

Table C.20: UECP data field

Syntax	No. of bits	Mnemonic
<code>UECP_data() {</code>		
<code>UECP_data_sync</code>	8	bslbf
<code>data_field_length</code>	8	bslbf
for (i=0; i<N; i++){		
<code>UECP_data_byte</code>	8	uimsbf
}		
<code>}</code>		

Semantics: The `UECP_data_sync` should be set to 0xFD.

The bytes in the UECF_data_byte field shall be byte aligned with the UECF data bytes. There is no need to align the UECF_data_byte field with the UECF frames. Consequently, one or more complete UECF frames and/or only parts of UECF frames may be contained in one UECF_data_byte field.

The length of the UECF_data_byte field can vary between consecutive audio packets.

Encoding: The encoding complies fully to the UECF specification [24].

The following addresses are assigned to DVB consumer receivers which are tuned to the indicated programme. For dual mono, the Terminal Address allows to assign different RDS information to the different audio channels.

NOTE: Within the DVB system the dual mono mode is generally deprecated. For legacy reasons, however, this option has been kept for RDS transmission.

Site Address	Terminal Address	DVB consumer receiver
0	0	All
1008	0	Stereo
	1	Dual Channel, ch. A
	2	Dual Channel, ch. B
	3	Single Channel (Mono)
	4 – 63	Not yet assigned

For professional decoding equipment at UKW/FM transmitters the addresses are individually assigned.

Decoding: It is recommended to parse the data from the end.

C.5 Detailed specification for MPEG-4 Audio

C.5.1 Transmission of MPEG-4 Audio ancillary data

Presence of MPEG-4 ancillary data shall be signalled in DVB SI by setting b_5 in *ancillary_data_identifier* to "1" (see EN 300 468 [6], table 16).

MPEG4 ancillary data as defined in this annex shall be placed into a single *data_stream_element()* as defined in ISO/IEC 14496-3, table 4.10 [17].

The *data_stream_element()* <DSE> shall follow any combination of related <SCE>, <CPE>, <LFE>, and <FIL <EXT-SBR_DATA>> audio elements, to which the ancillary data applies.

The *element_instance_tag* of this *data_stream_element()* shall have the same value as the *element_instance_tag* of the first audio element to which the ancillary data applies.

Examples of possible streams are:

for a 2-channel program:

<CPE><DSE><FIL><TERM><CPE><DSE><FIL><TERM>...

for a 2-channel program with SBR:

<CPE><SBR(CPE)><DSE><FIL><TERM><CPE><SBR(CPE)><DSE><FIL><TERM>...

for a 5.1-channel program

<SCE><CPE><CPE><LFE><DSE><FIL><TERM><SCE><CPE><CPE><LFE><DSE><FIL><TERM>...

For further reference see clauses 4.5.2.1.2 and 4.5.2.9.2 in ISO/IEC 14496-3 [17].

C.5.2 MPEG4 ancillary data syntax

The syntax of the ancillary data field is described in Table C.21. Data are transmitted in the order as given in the table.

Table C.21: MPEG4 ancillary data syntax

Syntax	No. of bits	Mnemonic
MPEG4 ancillary_data() {		
ancillary_data_sync	8	bslfb
bs_info	8	bslbf
ancillary_data_status	8	bslbf
If (downmixing_levels_MPEG4_status == 1)		
downmixing_levels_MPEG4	8	bslbf
If (audio_coding_mode_and_compression_status == 1) {		
audio_coding_mode	8	bslbf
Compression_value	8	bslbf
}		
if(coarse_grain_timecode_status == 1)		
coarse_grain_timecode	16	bslbf
if(fine_grain_timecode_status == 1)		
fine_grain_timecode	16	bslbf
}		

C.5.2.1 ancillary_data_sync

Encoding: *This field shall be set to 0xBC.*

Decoding: The decoder may use this field to verify the availability of the MPEG4 ancillary data.

C.5.2.2 bs_info

The detailed syntax is described in Table C.22.

Table C.22: bs_info syntax

Syntax	No. of bits	Mnemonic
bs_info() {		
mpeg_audio_type	2	bslbf
dolby_surround_mode	2	bslbf
reserved, set to "0000"	4	bslbf
}		

C.5.2.2.1 mpeg_audio_type

Table C.23: MPEG audio type Table

mpeg_audio_type	Description
"00"	Reserved
"01"	Reserved
"10"	Reserved
"11"	MPEG4 Audio data

Encoding: *This field shall be set according to Table C.23.*

Decoding: The decoder may ignore this field.

C.5.2.2.2 dolby_surround_mode

Table C.24: Dolby surround mode Table

mpeg_audio_type	Description
"00"	Dolby surround mode not indicated
"01"	2-ch audio part is not Dolby surround encoded
"10"	2-ch audio part is Dolby surround encoded
"11"	Reserved

Semantics: In case of 2-channel audio streams it can be indicated, whether the audio signal is encoded in Dolby surround mode. Encoding: This field may be provided by encoders when the audio stream is in 2-channel (stereo) format. *It shall be set to "00" for other than 2-channel audio streams.*

Decoding: It is recommended that the decoder parses this field and provides this information to the reproduction set-up.

C.5.2.3 ancillary_data_status

The detailed syntax is described on Table C.25.

Table C.25: ancillary_data_status syntax

Syntax	No. of bits	Mnemonic
ancillary_data_status() {		
Reserved, set to "0"	1	bslbf
Reserved, set to "0"	1	bslbf
Reserved, set to "0"	1	bslbf
downmixing_levels_MPEG4_status	1	bslbf
Reserved, set to "0"	1	bslbf
audio_coding_mode_and_compression_status	1	bslbf
coarse_grain_timecode_status	1	bslbf
fine_grain_timecode_status	1	bslbf
}		

Semantics: The bits in this field indicate the presence of the associated fields in the ancillary data.

Encoding: *A bit in this field shall be set to "1" if the associated field is present in the bitstream.*

Decoding: It is recommended that the decoder parse this field to allow parsing of the following fields in the ancillary data section.

C.5.2.4 downmixing_levels_MPEG4

When multichannel audio streams are decoded by an IRD and only 2-channel audio output is required, then matrix mix down has to be applied. For MPEG-4 AAC and MPEG-4 HE AAC matrix mix down is described in ISO/IEC 14496-3 [17].

This part of MPEG-4 ancillary data gives a possibility to transmit matrix mix down coefficients with higher resolution than defined in ISO/IEC 14496-3 [17]. The detailed syntax is described in table D.26.

Table C.26: downmixing_levels_MPEG4 syntax

Syntax	No. of bits	Mnemonic
downmixing_levels_MPEG4 () {		
center_mix_level_on	1	bslbf
center_mix_level_value	3	bslbf
surround_mix_level_on	1	bslbf
surround_mix_level_value	3	bslbf
}		

Encoding: This matrix mix down information may be supplied by the encoder.

Decoding: It is recommended that the decoder parses this field and uses the information in cases matrix mix down is needed.

C.5.2.4.1 center_mix_level_on

Semantics: This field indicates, whether the **center_mix_value** field carries information for matrix mix down.

Encoding: *If this field is set to "1" the **center_mix_value** field shall indicate the matrix mix down level of the centre channel with respect to the left and right front channels. If this field is set to "0" the **center_mix_value** field shall be set to "000".*

Decoding: It is recommended that the decoder parse this field.

C.5.2.4.2 surround_mix_level_on

Semantics: This field indicates, whether the **surround_mix_value** field carries information for matrix mix down.

Encoding: *If this field is set to "1" the **surround_mix_value** shall indicate the matrix mix down level of the surround channels with respect to the left and right front channels. If this field is set to "0" the **surround_mix_value** field shall be set to "000".*

Decoding: It is recommended that the decoder parse this field.

C.5.2.4.3 mix_level_value

Table C.27: Mix level value Table

mix_level_value	Multiplication factor
"000"	1.000 (0.0 dB)
"001"	0.841 (-1.5 dB)
"010"	0.707 (-3.0 dB)
"011"	0.596 (-4.5 dB)
"100"	0.500 (-6.0 dB)
"101"	0.422 (-7.5 dB)
"110"	0.355 (-9.0 dB)
"111"	0.000 ($-\infty$ dB)

Encoding: When provided, the values of **center_mix_level_value** and **surround_mix_level_value** shall be set to indicate the multiplication factors for 2-channel matrix mix down.

Decoding: The multi-channel decoder may apply these values as gain factors to the individual channels when a down mix for 2-channel stereo listening has to be created. The values need to be scaled to avoid overload after the mixing process.

C.5.2.5 audio_coding_mode

The detailed syntax is described in Table C.28.

Table C.28: audio coding mode syntax

Syntax	No. of bits	Mnemonic
audio_coding_mode () {		
reserved, set to "000 0000"	7	bslbf
compression_on	1	bslbf
}		

Decoding: It is recommended that the decoder parse this field.

C.5.2.5.1 compression_on

Semantics: This field indicates, whether the **compression_value** field carries information.

Encoding: If this field is set to "1" the **compression_value** field indicates the heavy compression factor used for monophonic down mix reproduction. *If this field is set to "0" the **compression_value** field shall be "0000 0000".*

Decoding: It is recommended that the decoder parse this field.

C.5.2.5.2 compression_value

Semantics: This field consists of a value X in the four msb's and a value Y in the four lsb's. The actual value is $48.164 - 6.0206 X - 0.4014 Y$ dB.

Encoding: The encoder may provide this information.

Decoding: *When available, the IRD shall apply these values to the spectral samples, before the reconstruction transform, when the decoder has to create a mix for monophonic listening where overloading of a subsequent analog transmission is highly undesirable.*

C.5.2.6 coarse_grain_timecode

See clause C.4.2.13.

C.5.2.7 fine_grain_timecode

See clause C.4.2.14.

C.5.3 Announcement Switching Data

The transmission of announcement switching data in MPEG4 ancillary data is optional. The syntax of the announcement switching data field is described in Table C.29.

Table C.29: Announcement switching data field

Syntax	No. of bits	Mnemonic
announcement_switching_data() {		
announcement_switching_data_sync	8	bslbf
data_field_length	8	bslbf
announcement_switching_flag_field_1	16	bslbf
announcement_switching_flag_field_2	16	bslbf
}		

Semantics: The **announcement_switching_data_sync** should be set to 0xAD.
The **data_field_length** gives the number of bytes following this byte within this data field.

The **announcement_switching_flag_fields** are 16-bit flag fields specifying which type of announcements are actually running. *The association between the bits of the flag field and the announcement types shall be according to **the announcement_support_indicator** [6]. A bit shall be set to "1" if the announcement is running and it shall be set to "0" if the announcement is not running.*

*The **announcement_switching_flag_field_1** shall be used for announcements within the audio elementary stream that is actually decoded.*

*The **announcement_switching_flag_field_2** shall be used for announcements within other audio elementary streams. Corresponding links shall be provided by means of the **announcement_support_descriptor** [6].*

Decoding: It is recommended that the decoder parse this field.

Annex D (informative): Coding of Data Fields in the Private Data Bytes of the Adaptation Field

D.1 Introduction

This annex contains the guidelines required to include and to decode data fields in the private data bytes of the adaptation field [1].

D.2 Detailed specification

Transport stream (TS) packets coded according to ITU-T Recommendation H.222.0 | ISO/IEC 13818-1 [1] may include an adaptation field. The presence of an adaptation field is indicated by means of the `adaptation_field_control`, i.e. a 2-bit field in the header of the TS packet. The adaptation field itself may contain `private_data_bytes`. The presence of private data bytes is signalled by means of the `transport_private_data_flag` coded at the beginning of the adaptation field. If private data bytes exist the total number of private data bytes is specified by means of the `transport_private_data_length`, an 8-bit field that is directly followed by the private data bytes. The private data bytes may be composed of one or more data fields as shown in Figure D.1. Gaps are not allowed between two data fields.

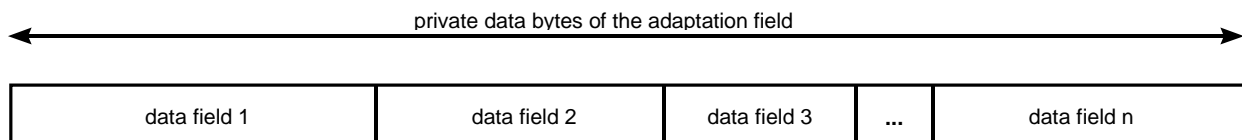

Figure D.1: Coding scheme for private data bytes within the adaptation field

Encoding: *The support of data fields that are specified in this annex shall be indicated by means of the `adaptation_field_data_descriptor` [7]. This descriptor shall be inserted in the corresponding `ES_info` loop.*

Moreover, the following semantics apply to all data fields specified in this annex.

`data_field_tag`: The data field tag is an 8-bit field which identifies the type of each data field. The values of `data_field_tag` are defined in Table D.1.

`data_field_length`: The data field length is an 8-bit field specifying the total number of bytes of the data portion of the data field following the byte defining the value of this field.

Table D.1: Allocation of `data_field_tags`

<code>data_field_tag</code>	Description
0x00	Reserved
0x01	Announcement switching data field
0x02	AU_information data field
0 x 03 to 0 x 9F	Reserved for future use
0 x A0 to 0 x FF	User defined

Decoding: The IRD design should be made under the assumption that any structure as permitted by this annex may occur in the broadcast stream. The IRD is not required to make use of this data.

D.2.1 Announcement Switching Data

The announcement switching data field is used to indicate whether spoken announcements are actually running or not. In comparison with that, the general support of announcements is indicated by means of the `announcement_support_descriptor` [7].

The transmission of the announcement switching data field is optional but it shall be continuously provided in those audio streams that may carry announcements at some point in time. The announcement switching data field shall be present at least every 100 ms. The syntax of the announcement switching data field is described in Table D.2.

Table D.2: Announcement switching data field

Syntax	No. of bits	Mnemonic
<code>announcement_switching_data() {</code>		
<code>data_field_tag</code>	8	uimsbf
<code>data_field_length</code>	8	uimsbf
<code>announcement_switching_flag_field</code>	16	bslbf
<code>}</code>		

Semantics: `announcement_switching_flag_field`: This 16-bit flag field specifies which type of announcements are actually running. *The association between the bits of the flag field and the announcement types shall be according to the `announcement_support_descriptor` that is specified for the `announcement_support_descriptor` [7]. A bit shall be set to "1" if the announcement is running and it shall be set to "0" if the announcement is not running.*

D.2.2 AU_information

The `AU_information` data field is used to signal the presence of the start of an access unit in the payload of the transport packet containing the data field, and to convey information about that access unit that is of use to PVR applications. All the information provided in this descriptor should be considered "helper" information rather than definitive information. *Thus, if there are any conflicts between the information signalled in this descriptor and the actual stream, then the information in the stream shall take precedence over the information in this descriptor.* However, such a conflict should be considered an error condition and as such should not occur. It is recommended that the `AU_information` data field is present at the start of each access unit of an H.264/AVC [16] video streams.

Where multiple access units occur in a transport packet, then multiple `AU_information` data fields may be used. *Each descriptor shall apply to the corresponding access unit in the transport packet. I.e. the first data field shall apply to the first access unit starting in the transport packet, the second data field shall apply to the second access unit starting in the transport packet, etc.*

The `AU_information` data field(s), when present, shall be the first data field(s) in the adaptation field.

There shall not be more descriptors than there are access units starting in the packet.

The presence of `AU_information` data fields shall be indicated via bit b_1 of the `adaptation_field_data_identifier` in the adaptation field descriptor.

Table D.3: AU_information data field

Syntax	No. of Bits	Mnemonic
AU_information () {		
data_field_tag	8	uimsbf
data_field_length	8	uimsbf
AU_coding_format	4	uimsbf
AU_coding_type_information	4	bslbf
AU_ref_pic_idc	2	uimsbf
AU_pic_struct	2	bslbf
AU_PTS_present_flag	1	bslbf
AU_profile_info_present_flag	1	bslbf
AU_stream_info_present_flag	1	bslbf
AU_trick_mode_info_present_flag	1	bslbf
if (AU_PTS_present_flag == "1") {		
AU_PTS_32	32	uimsbf
}		
if (AU_stream_info_present_flag == "1") {		
Reserved	4	"0000"
AU_frame_rate_code	4	uimsbf
}		
if (AU_profile_info_present_flag == "1") {		
AU_profile	8	uimsbf
AU_constraint_set0_flag	1	bslbf
AU_constraint_set1_flag	1	bslbf
AU_constraint_set2_flag	1	bslbf
AU_AVC_compatible_flags	5	bslbf
AU_level	8	uimsbf
}		
if (AU_trick_mode_info_present_flag == "1") {		
AU_max_I_picture_size	12	uimsbf
AU_nominal_I_period	8	uimsbf
AU_max_I_period	8	uimsbf
Reserved	4	"0000"
}		
if (data_parsed < data_field_length) {		
AU_Pulldown_info_present_flag	1	bslbf
AU_reserved_zero	6	"000000"
AU_flags_extension_1	1	bslbf
if (AU_Pulldown_info_present_flag == "1") {		
AU_reserved_zero	4	"0000"
AU_Pulldown_info	4	bslbf
}		
if (AU_flags_extension_1 == "1") {		
AU_reserved	8	bslbf
}		
}		
for(i=0; i<n; i++) {		
AU_reserved_byte	8	bslbf
}		
}		

Semantics:

data_field_tag: this shall have the value 0x02.

data_field_length: this indicates the length of the descriptor. The values 0 and 1 may be used to signal short versions of the descriptor. The value 0 means that no fields after the data_field_length are sent, and is used as a dummy descriptor. The value 1 means that only the fields AU_coding_format and AU_coding_type_information are present.

AU_coding_format: This shall signal the coding format used by the elementary stream carried on this packet. The values are as show in Table D.4.

Table D.4: AU_coding_format values

Value	Stream Type
0	Undefined
1	ITU-T Rec H.262 ISO/IEC 13818-2 [2] Video or ISO/IEC 11172-1 [8] constrained parameter video stream
2	H.264/AVC video stream as defined in ITU-T Recommendation H.264 ISO/IEC 14496-10 [16] Video
3	VC-1 video stream as defined in SMPTE 421M [21].
4-0xF	reserved

AU_coding_type_information: indicates the elementary stream types present in the immediately following access unit. For ITU-T Recommendation H.264 | ISO/IEC 14496-10 [16] video, this field shall be interpreted as a four bit field with the syntax shown in Table D.5.

Table D.5: AU_coding_type_information for ITU-T Recommendation H.264 | ISO/IEC 14496-10 [16] video

Syntax	No. of Bits	Mnemonic
AU_IDR_slice_present_flag	1	bslbf
AU_I_slice_present_flag	1	bslbf
AU_P_slice_present_flag	1	bslbf
AU_B_slice_present_flag	1	bslbf

For ITU-T Recommendation H.262 | ISO/IEC 13818-2 [2] Video, this field shall be interpreted according to Table D.6. These values are identical to (but one bit longer than) the values in table 6-12 of ISO/IEC 13818-2 [2].

For VC-1 (SMPTE 421M), this field shall be interpreted as per Table D.6.

Table D.6: AU_coding_type_information for ITU-T Recommendation H.262 | ISO/IEC 13818-2 [2] video

Value	AU_coding_type_information
0	Undefined
1	I
2	P
3	B
4-0xF	Reserved

AU_ref_pic_idc: This field indicates if any of the access unit is required in the reconstruction of other access units. The value "00" means that it is not used by other access units. In the case of ITU-T Recommendation H.264 | ISO/IEC 14496-10 [16], the value shall be the nal_ref_idc field in the NAL header used for any slice that makes up the access unit.

For VC-1 (SMPTE 421M) [21], this shall take the value '00' for all pictures (and related headers) that are not used as reference, and shall not take the value '00' for all pictures that are used as reference.

For ITU-T Recommendation H.262 | ISO/IEC 13818-2 [2], this field shall take the value '00' for pictures (and related headers) that are not used as reference (i.e. B pictures), and shall not take the value '00' for all other pictures (and related headers).

AU_pic_struct: This field shall be set to "01" if the access unit is a top field picture, "10" if it is a bottom field. Otherwise, it shall be set to "00". "11" value is reserved.

AU_PTS_present_flag: This field shall be set to "1" when the AU_PTS_32 value is present in the descriptor, otherwise it shall take the value "0".

AU_profile_info_present_flag: This field shall be set to "1" when the AU_profile_idc and AU_level_idc values are present in the descriptor, otherwise it shall take the value "0".

AU_stream_info_present_flag: This field shall be set to "1" when the AU_frame_rate_code value is present in the descriptor, otherwise it shall take the value "0".

AU_trick_mode_info_present_flag: This field shall be set to "1" when the *AU_max_I_picture_size* and *AU_max_I_period* are present in the descriptor.

AU_PTS_32: the 32 most significant bits of the 33-bit PTS encoded in the PES header immediately following this adaptation field, or of the value that applies to the access unit to which this descriptor applies, if no PES header is present.

AU_frame_rate_code: this field indicates the video frame rate in the stream carried on the current PID. In the case of video, this is encoded as in clause 6.3.3 of ISO/IEC 13818-2 [2]:2000, as shown in table 6-4 of the same. The values in this table are informatively replicated on Table D.7.

Table D.7: Informative Frame Rate values taken from table 6-4 of 13818-2:2000

AU_frame_rate_code	Corresponding Frame Rate (Hz)
0	Forbidden
1	23.976
2	24
3	25
4	29.97
5	30
6	50
7	59.94
8	60
9 to 0xF	Reserved

AU_profile: this field conveys the profile used to which the access unit conforms.

For ITU-T Recommendation H.264 | ISO/IEC 14496-10 [16] video this contains the *profile_idc* value as defined ISO/IEC 14496-10 [16], annex A.

For ITU-T Recommendation H.262 | ISO/IEC 13818-2 [2] video the least significant 3 bits of this field carry the profile as defined in clause 8 of ITU-T Recommendation H.262 | ISO/IEC 13818-2 [2].

For VC-1 (SMPTE 421M) [21] video the least significant bits of this field carry the profile as defined in SMPTE 421M [21].

Constraint_set0_flag, constraint_set1_flag, constraints_set2_flag, AVC_compatible_flags: These fields carry the same semantics as the fields of the same name in the *AVC_video_descriptor* in clause 2.6.54 of ISO/IEC 13818-1: [1] 2000 (AMD3), which in turn have semantics defined in ISO/IEC 14496-10 [16] **Error! Reference source not found.**, clause 7.4.2.1. Note that with High profile, the first bit in *AVC_compatible_flags* contains *constraint_set3_flag*.

For ITU-T Recommendation H.262 | ISO/IEC 13818-2 [2] video and VC-1 (SMPTE 421M) [21] video these fields shall take the value '0'.

AU_level: this field conveys the level used to which the access unit conforms.

For ITU-T Recommendation H.264 | ISO/IEC 14496-10 [16] video this carries the *level_idc* value as defined ISO/IEC 14496-10 [16], annex A.

For ITU-T Recommendation H.262 | ISO/IEC 13818-2 [2] video the least significant 4 bits of this field carry the level as defined in clause 8 of ITU-T Recommendation H.262 | ISO/IEC 13818-2 [2].

For VC-1 (SMPTE 421M) video, the least significant bits of this field shall carry the level as defined in SMPTE 421M [21].

AU_max_I_picture_size: this value indicates the buffer size, in units of 16x1024 bits, that is implemented by the encoder rate control, and thus the maximum intra picture size that can be found in the current bitstream. This value, according to profile and level, shall comply with ISO/IEC 14496-10 [16] **Error! Reference source not found.** and ISO/IEC 13818-2 [2] limits. The value 0 is forbidden.

AU_nominal_I_period: this value indicates the nominal distance between two consecutive I/IDR pictures, on a frame picture count basis. The value 0 is forbidden.

AU_max_I_period: this value indicates the maximum distance that can be found in the stream between two consecutive I/IDR pictures, on a frame picture count basis. The value 0 is forbidden.

AU_Pulldown_info_present_flag: this field shall be set to “1” if the AU_Pulldown_info field is present.

AU_flags_extension_1: this field shall be set to “1” if the AU_reserved bytes is used for additional flags.

NOTE: This flag provides for future extensions. Whilst for the current specification, the value of this flag should be “0”, the value of “1” should be correctly processed.

AU_Pulldown_info: This field carries the four bits carried in the H.264/AVC structure signalling the AU’s display characteristics, specifically the pic_struct field of the SEI message pic_timing. The default value for this field shall be the same as AU_pic_struct. Table D.9 below shows the default values to be used for Pulldown_info if the field is not transmitted.

Table D.8: AU_Pulldown_info default values

AU_pic_struct default	AU_Pulldown_info value
00	0
01	1
10	2

Annex E (informative): Receiver-Mixed Audio Description and other supplementary Audio Services

E.1 Overview

Audio description (AD) delivers a description of the scene as an ancillary component associated with a TV service. It is intended to aid understanding and enjoyment particularly, but not exclusively, for viewers who have visual impairments.

Loud sound effects or music could make added description hard to discern so an important requirement is to adjust, on a passage-by-passage basis, the relative level of programme sound in the mix which the AD user hears. The programme maker is best able to determine the level under controlled conditions when authoring the AD - information to modulate the level of programme sound in the AD-capable receiver is thus transmitted within the AD stream.

Individual AD users will have different aural acuity, describers will have different styles of delivery (voice pitch and timbre), several voices may be used to describe one programme and there are, in practice, differences in audio signal level for different home receivers. An essential requirement is for the user to be able to adjust the volume of the description signal to suit his/her condition.

The ability to optionally mix one or more supplementary additional audio channels with the main programme sound can have other applications, including multi-language commentaries, use for interactivity, and educational purposes.

E.2 Coding

Description content is voice only and is conveyed as a mono signal coded in accordance with ISO/IEC 11172-3 [9].

The principles of processing in a basic AD decoder are shown diagrammatically below in Figure E.1.

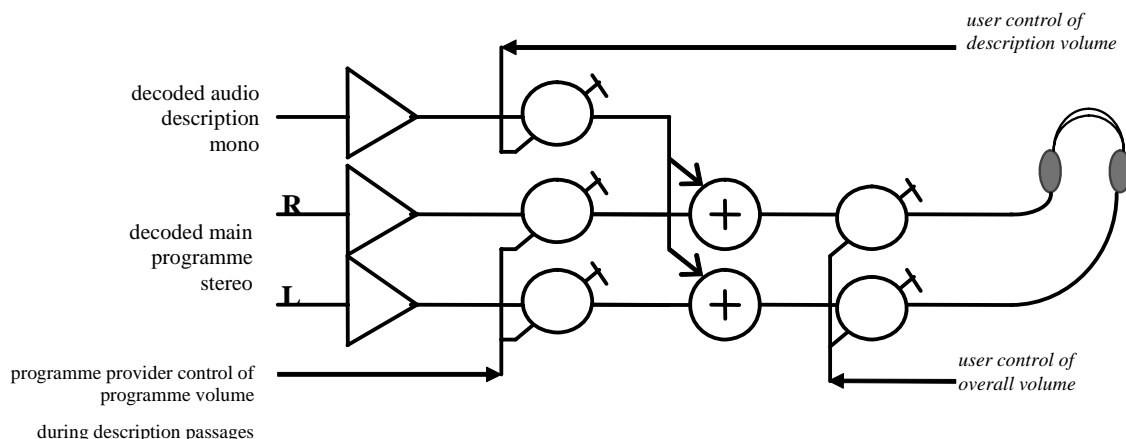

Figure E.1: Functionality of AD decoder processing

The level by which the programme sound should be attenuated during a description passage is signalled in PES_private_data within the PES encapsulation of the coded AD component (as specified in ITU-T Recommendation H.222.0 | ISO/IEC 13818-1 [1]).

- Encoding : Support for the encoding of AD is optional.
Decoding : Support for the encoding of AD is optional.

The signalled fade value is an unsigned byte value, 0x00 representing 0 dB, each increment representing a nominal 0,3 dB, 0xFE representing approximately -77 dB whilst the fade value 0xFF represents completely mute programme sound.

A pan control value is also included within the transmitted data structure, enabling the decoded AD signal to be panned around the sound stage of the main programme sound and thus allowing the programme maker to place the "describer" at any preferred position within the sound field. As with fade, transmitted pan is a byte value, 0x00 representing centre front where each increment represents about 1.4° clockwise looking down on the listener (see Figure E.2 below). For stereo the pan value will be restricted to $\pm 30^\circ$ of the centre front (i.e. to the range 0xEB..0xFF & 0x00..0x15) but the syntax of the signalling allows for any future use in which an AD component might be provided with a surround-sound main programme audio.

The values of fade & pan signalled in a PES packet apply to each access unit of AD sound contained within that same PES packet. This allows a fade (and a pan) to be relatively gradual or to be abrupt as the programme material allows.

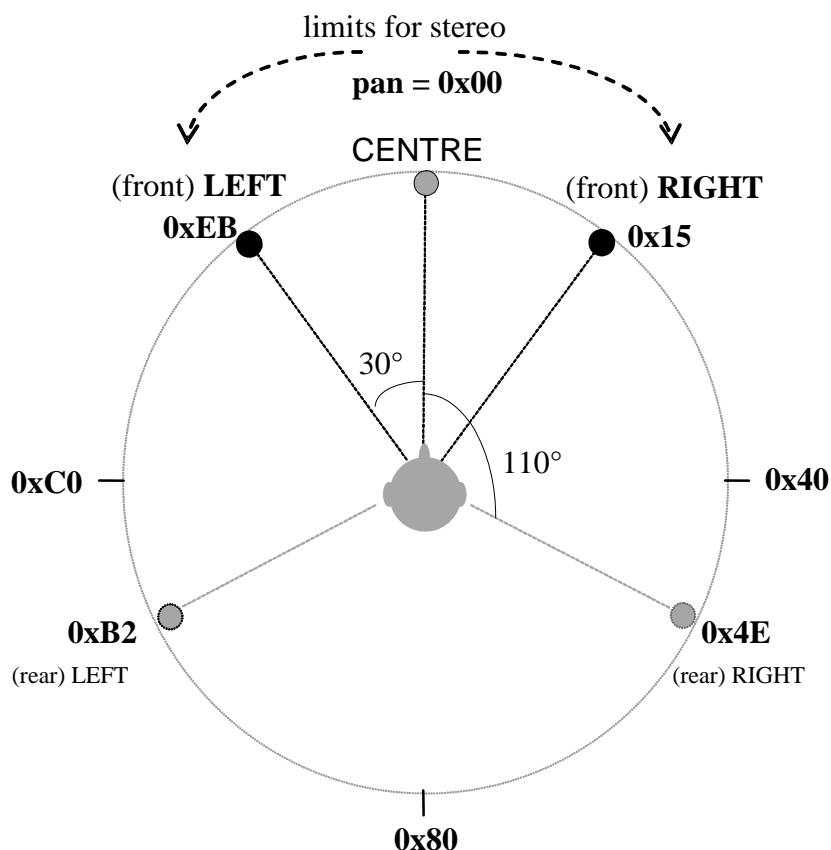

NOTE: (Seen from above the listener; includes mapping onto multi-channel sound presentation).

Figure E.2: interpretation of audio description pan value

E.2.1 Syntax and Semantics

AD fade & pan control information is coded in PES_private_data within the PES encapsulation of the coded AD component in accordance with ITU-T Recommendation H.222.0 | ISO/IEC 13818-1 [1].

Table E.1: AD_descriptor

Syntax	value	No.of bits	Identifier
AD_descriptor {			
Reserved	1111	4	bslbf
AD_descriptor_length	1000	4	bslbf
AD_text_tag	0x4454474144	40	bslbf
revision_text_tag	0x31	8	bslbf
AD_fade_byte	0xXX	8	bslbf
AD_pan_byte	0xYY	8	bslbf
Reserved	0xFFFFFFFFFFFFFFF	56	bslbf
}			

AD_descriptor_length: the number of significant bytes following the length field (i.e. 8).

AD_text_tag: a string of 5 bytes forming a simple and unambiguous means of distinguishing this from any other PES_private_data. A receiver which fails to recognize this tag should not interpret this audio stream as audio description.

revision_text_tag: the AD_text_tag is extended by a single ASCII character version designator (here "1" indicates revision 1). *Descriptors with the same AD_text_tag but a higher revision number shall be backwards compatible with this specification* - the syntax and semantics of the fade & pan fields will be identical but some of the reserved bytes may be used for additional signalling.

AD_fade_byte: takes values between 0x00 (representing no fade of the main programme sound) and 0xFF (representing a full fade). Over the range 0x00 to 0xFE one lsb represents a step in attenuation of the programme sound of approximately 0.3 dB giving a range of about 77 dB. The fade value of 0xFF represents no programme sound at all (i.e. mute). The rate of signalling and the expected behaviour of a decoder to changes in fade byte are described below.

AD_pan_byte: takes values between 0x00 representing a central forward presentation of the audio description and 0xFF, each increment representing a $360/256$ degree step clockwise looking down on the listener (i.e. just over 1.4 degrees, see Figure E.2 above). The rate of signalling and the expected behaviour of a decoder are described below.

reserved: the remaining 7 bytes are set to 0xFF and reserved for future developments if and when required.

The maximum rate of signalling of fade & pan values is determined by the number of audio PES packets per second for that AD stream. For efficiency several access units (AUs) of audio are typically encapsulated within one PES packet and the fade & pan values in each AD_descriptor are deemed to apply to each AU encapsulated within, and which commences in, that PES packet. In typical efficient encapsulation fade & pan values are transmitted every 120 ms to 200 ms. This allows the control over the attack and decay of a fade where a particular gap in the narrative permits.

An AD decoder must maintain the relative timing between the decoded description signal and the decoded programme sound signal and between the appropriate fade & pan values and the decoded description signal.

During programmes for which there is no description there is little reason to transmit an AD stream of continual silence; in these cases the bit-rate accorded to AD may be reassigned for other purposes. Decoders should therefore be able to respond promptly to the restoration of the AD component at the start of a described programme.

The streams for programme sound and for AD are distinguished in the PSI by the use of the ISO_639_language descriptor. The audio_type field within the descriptor associated with programme sound is typically assigned the value 0x00 ("undefined") whilst the equivalent descriptor associated with AD has its audio_type field assigned the value 0x03 ("visual impaired commentary"). If a service has AD in several languages the PMT reference to each stream will have the appropriate ISO_639_language_code and the AD-capable decoder should discriminate between them on the basis of the preferred language chosen in the user settings.

E.3 Decoder behaviour

If there is a valid AD descriptor in the encoded description signal for the selected service, the AD decoder should present the appropriate mix of programme sound and description signal to the user, attenuating the programme sound by 0.3 dB per fade value increment. If the AD decoder cannot support such small steps then the implemented attenuation should match the intended attenuation as closely as possible. For example if only 1 dB steps are possible then fade values of 0x00 and 0x01 should map to 0 dB, 0x02, 0x03 and 0x04 should map to 1dB, 0x05, 0x06, 0x07 & 0x08 to -2 dB etc.

When the fade value is 0x00 (or in the absence of an AD stream) the programme sound level should be unattenuated. Care should be taken to ensure that the default levels of programme sound and description are consistent when fed with streams coding standard level signals. It is also important that the mono description is matrixed to the stereo output so as to achieve a constant perceived description volume as the description is panned from stereo left through stereo centre to stereo right.

NOTE 1: E.g. using a model based on constant power as the description is panned across the stereo sound stage.

NOTE 2: The perceived loudness level of the main programme audio may well vary between different broadcast services. If the main programme audio is derived from a system using gain control metadata, for example AC-3, then the perceived loudness of the programme dialogue should be constant but it is likely to be different to that of a service for which the programme sound is delivered as MPEG-1 layer II. For any receiver which can decode main audio sources other than MPEG-1 layer II, the manufacturer may need to consider implementing different default gain levels for the audio description signal to provide a reasonable match of loudness to that of the programme dialogue. The ability of the user to adjust the relative level of description should nevertheless be retained.

In a stereo environment the AD decoder should interpret any pan values outside the ranges 0xEB..0xFF and 0x00..0x15 in the following manner. Pan values from 0x16 to 0x7F inclusive should be mapped to the value 0x15 (i.e. stereo hard right). Pan values from 0x80 to 0xEA should be mapped to the value 0xEB (i.e. stereo hard left).

When the user selects a new service or if the AD decoder detects an error in, or absence of, the AD descriptor in the encoded AD signal, the AD decoder should have a strategy which leads to muting the decoded description signal, restoring the programme sound to its default unfaded amplitude and setting the effective fade & pan values to 0x00. This restoration should not be abrupt - it is recommended that under such conditions the value of fade and of pan are ramped to the default values (0x00) over a period of at least 1 second. Equally, if the AD stream component is suddenly regained the implemented value of fade and of pan should be ramped to the signalled values from the default values (0x00) over a similar period.

E.4 Decoder user indicators

Description is typically confined to gaps in the programme narrative; these opportunities are therefore dependent on the programme. Some programmes are more suited to description than others; one may be effectively self-describing whilst another (e.g. news or a studio interview) might offer no opportunity for descriptive interpolation. Receiver implementations of AD should therefore allow the user to confirm that, in what may be extended gaps between description passages, description silence does not necessarily imply failure in delivery of the service or in the receiving equipment.

Many potential users of AD will be visually impaired. The user interface should not, therefore, rely solely on visual clues (lights or on-screen display logos) to indicate status (e.g. presence or absence of description). Audible indications are desirable and designers should consider how to distinguish different states using, for example, contrasting tones.

Annex F (informative): Encoding Guidelines to Enable Trick Play Support of H.264/AVC Streams

F.1 Introduction

F.1.1 Overview

This appendix discusses informative guidelines on the encoding of H.264/AVC bitstreams to enable support of trick play modes. MPEG-2 personal video recording devices and services are increasingly being used in the marketplace and it is reasonable to expect this trend to continue. As industry migrates to the H.264/AVC standard, it is therefore also reasonable to believe that consumers will expect the functionality of their H.264/AVC PVR services to be at least as good as (and most likely better than) their MPEG-2 counterparts. It is important to recognize that the unofficial widely-adopted methods of MPEG-2 encoding directly enabled many of the techniques currently used to achieve trick mode functionality. The same is true of VC-1 encodings. Note that MPEG-2 video can be encoded in a manner that makes PVR very difficult but since most encoders encoded bitstreams in a “PVR-friendly” manner, this was not an issue with MPEG-2 bitstreams. Again, the same is true of VC-1 encodings. Currently, the lack of syntax and semantics constraints on H.264/AVC bitstreams combined with the rich set of video coding tools in H.264/AVC allows for a wide variety of potential bitstreams with some being very problematic for any type of sophisticated bitstream manipulation such as the trick modes in H.264/AVC PVR implementations. For these reasons, the guidelines in this appendix were constructed to assist encoders to create H.264/AVC bitstreams that are “PVR-friendly” while not imposing significant constraints that would impact coding efficiency. Note that this appendix is informative since it is understood that enabling trick play support is an optional feature that may or may not be appropriate depending on its intended use.

F.1.2 Technical Requirements

One class of trick play modes consists of the desire to play back the video at a speed that is a multiple of real-time playback. Let a Nx trick play mode (where N is a positive number greater than 1) represent video playback at a speed of N times real-time playback. For example, a $3x$ trick play mode may be desired which would allow a user to fast forward through a program three times as fast as normal playback, i.e., in one-third the time. It is often desired for these trick modes to be relatively “smooth”, i.e., an Nx trick mode (where N is a positive integer) requires (at least approximately) every N th picture in the bitstream to be displayed. For example, repeating every thirtieth picture ten times would not constitute a “smooth” $3x$ trick mode using this definition. This “smooth” requirement may not be required for very fast trick modes like $15x$ or $30x$ fast forward since the human visual system cannot process such rapid motion. However, this requirement is desirable for trick modes such as $2x$ and $3x$ fast forward to obtain the satisfactory visual appearance of moving objects during the trick play.

In general, without any encoding constraints, the minimum requirement to implement trick modes is for the decoding to be done at the same speed as the desired trick mode to ensure that every prediction region is available for use in the motion compensation process, e.g., a decoder that runs at three times the normal speed of decoding is needed to guarantee $3x$ fast forward functionality. Note that this is a significant increase from the minimum requirement needed for normal playback. This approach has been done before for trick play with MPEG-2 standard definition content but is not practical or cost effective for many current and future applications. For example, decoding HD H.264/AVC video at three times the normal decoding speed is currently not possible in a cost-efficient fashion and even if this increased capability were made available in the future, it may not be desirable because of the increased cost relative to the minimum requirement for normal playback. This leads to a key technical assumption for the cost-effective implementation of trick play modes:

- Encoding intended for trick-play will be done in such a way that it does not burden decoders to decode pictures at a rate faster than normal playback to implement a trick play mode.

F.2 Discardable Pictures

Many PVR implementations drop pictures in the bitstream (i.e., skip over and do not present these pictures to the decoder) to circumvent the need to decode bitstreams at speeds that are a multiple of real-time decoding. The visual

effect of decoding at a multiple of real-time decoding can then be achieved using a normal decoder. This is only possible if a dropped picture is not needed for display and also not needed as a reference frame for another picture that is needed for display. These pictures are termed “discardable” pictures. The following sections will discuss how the “discardable” pictures concept was exploited in MPEG-2 trick play implementations and then how this same concept can be used to implement H.264/AVC trick play.

F.2.1 MPEG-2 Discardable Pictures

In the MPEG-2 video standard, B-pictures are not allowed to be used as reference pictures for motion compensation. This has a significant benefit for trick play modes since any B-pictures in a MPEG-2 bitstream can be dropped without affecting the decodability of other pictures. The “discardability” property of B-pictures is commonly used by many MPEG-2 trick mode implementations.

Figure F.1 illustrates the unofficial but widely-adopted MPEG-2 GOP structure, the IBBP GOP structure, which has two B-pictures placed between every pair of anchor I- and/or P-pictures. By dropping the B-pictures in this type of stream and passing the remaining pictures to the decoder, the visual effect of 3x fast forward trick play can be implemented with a decoder running at normal playback speed.

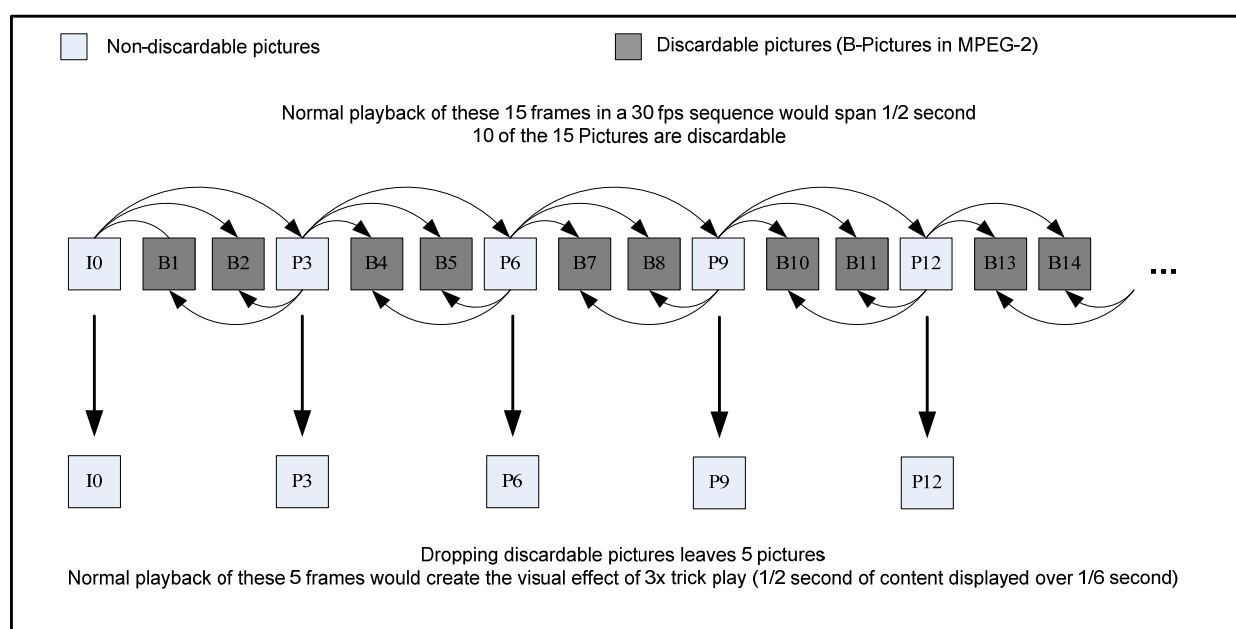

Figure F.1: Example of achieving a 3x trickplay mode from a common MPEG-2 GOP structure (IBBP)

Figure F.2 illustrates a MPEG-2 GOP structure, the IPPP GOP structure, where no B pictures are placed between every pair of anchor I- and/or P- pictures. Note that this structure is compliant to MPEG-2 but the technique of dropping B-pictures described above will not create a 3x trick play mode with this MPEG-2 coding structure since there are not enough B-pictures to drop (there is only one discardable picture at the end of the MPEG-2 GOP). In this case, a decoder that can run at N times normal decoding speed is necessary to support N times fast forward trick play since every picture is dependent on the previous picture in the MPEG-2 GOP.

Note that the problematic effect on PVR of a bitstream with a coding structure as shown in Figure F.1 has often been overlooked and not usually an issue because this type of MPEG-2 GOP structure is rarely used in broadcast applications.

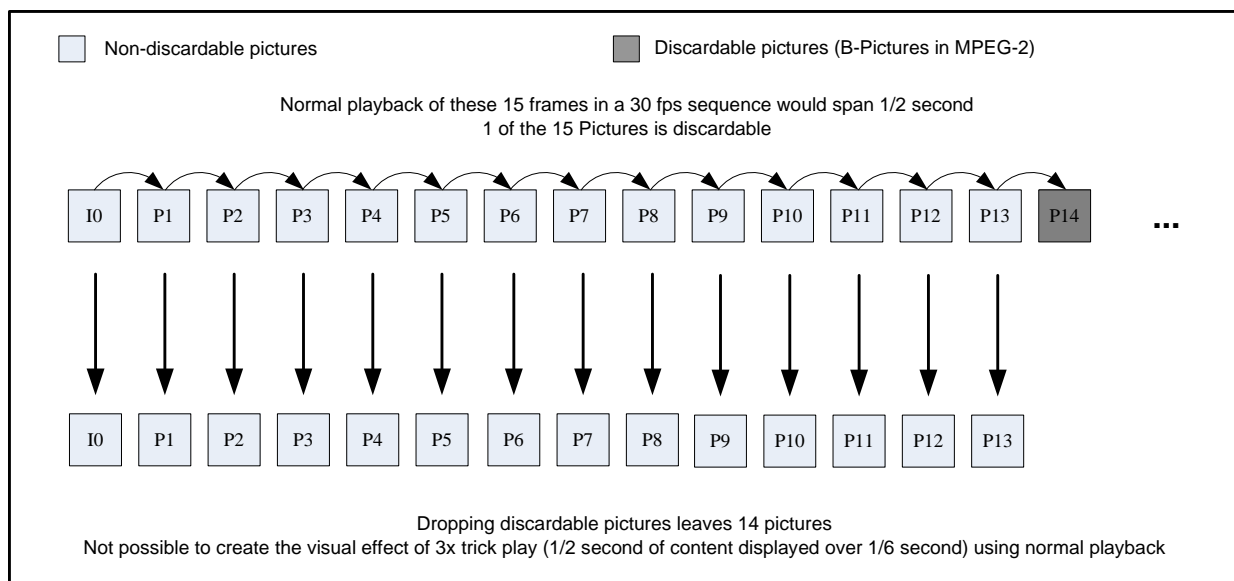

Figure F.2: Example of a compliant MPEG-2 GOP structure (IPPP) that cannot achieve 3x trick play by discarding pictures

F.2.2 H.264/AVC Discardable Pictures

The H.264/AVC compression standard has some substantial differences compared to MPEG-2 that significantly affect the picture coding structure and complicate trick mode implementations. These include the fact that B-pictures can be used as reference pictures for prediction, i.e., not all B-pictures are discardable as in MPEG-2. Note that the discardability of pictures is specifically indicated in the H.264/AVC standard by the `nal_ref_idc` flag in the NAL header (`nal_ref_idc = 0` indicates a discardable picture). Therefore, for H.264/AVC bitstreams, the important factor in trick mode functionality is the location of discardable pictures, not the location of B-pictures as in MPEG-2. The presence of discardable pictures determines the feasibility of dropping pictures that are not needed for display to achieve the visual effect of a trick play mode.

F.2.3 Discardable Pictures and Trick Play Speeds

The percentage of pictures in the bitstream that are discardable determines the maximum trick play speed that could be achieved by just dropping discardable pictures while operating the decoder at normal processing speeds. The formula below can be used to associate the percentage of discardable pictures with the maximum trick play speed that could be achieved by dropping discardable pictures:

$$\text{Trick Play Speed} = 100 / (100 - X) \text{ where } X \text{ is the percentage of discardable pictures}$$

Examples using common ratios of discardable pictures are listed in Table F.1:

Table F.1: Discardable Picture Percentages and Maximum Achievable Trick Play Speeds by discard process

Percentage of Discardable Pictures	Maximum Trick Play Speed Achievable By Dropping Pictures
16% (1/6 of the pictures)	1.2x
20% (1/5 of the pictures)	1.25x
25% (1/4 of the pictures)	1.33x
33% (1/3 of the pictures)	1.5x
50% (1/2 of the pictures)	2x
66% (2/3 of the pictures)	3x
75% (3/4 of the pictures)	4x

Note: Trick play speeds slower than the maximum achievable by dropping pictures can always be created by choosing to display some of the discardable pictures.

F.2.4 Smooth Trick Play and Compression Efficiency

Constraining a certain percentage of pictures in the bitstream to be discardable is necessary to enable the technique of dropping discardable pictures to achieve a trick play mode. However, it is important to recognize that determining the interval period between pictures where this percentage is constrained has a tradeoff between whether a smooth trick play is achieved and the coding structure which can impact coding efficiency. For example, Figure F.3 and Figure F.4 both illustrate coding structures with 66% of its pictures as discardable pictures (in both cases 10 of the 15 total pictures are discarded).

Figure F.3 has a more regular discardable picture structure and represents the further requirement of 2 out of every 3 pictures to be discardable. Dropping the discardable pictures in Figure F.3 will result in smooth 3x playback since every third picture in the original stream remains. However, note that the tradeoff for the ability to create a smooth 3x trick play is that the discardable picture structure places a tight constraint on the encoding which could reduce compression efficiency.

Ten out of the 15 total pictures in Figure F.4 are discardable as in Figure F.3, but its discardable picture structure is not as regular. Dropping the discardable pictures in Figure F.4 will not result in a smooth trick play experience as in Figure F.3. However, note that dropping discardable pictures can still be used to achieve the visual effect of playing through the content at three times the speed (since 5 frames remain) but without the serious constraint on the encoding.

NOTE: Although structure may not always guarantee smooth playback, there are methods that could create an appearance of smoother playback by means outside of this appendix.

To enable trick play support and still facilitate maximum compression efficiency, the percentage of discardable pictures will be calculated over the length of a H.264/AVC GOP (which, at the maximum 5 second time interval between the DTS of successive RAPs, may be up to 300 pictures). Encoding for the smoothest trick-play will distribute discardable pictures evenly in time throughout the H.264/AVC GOP.

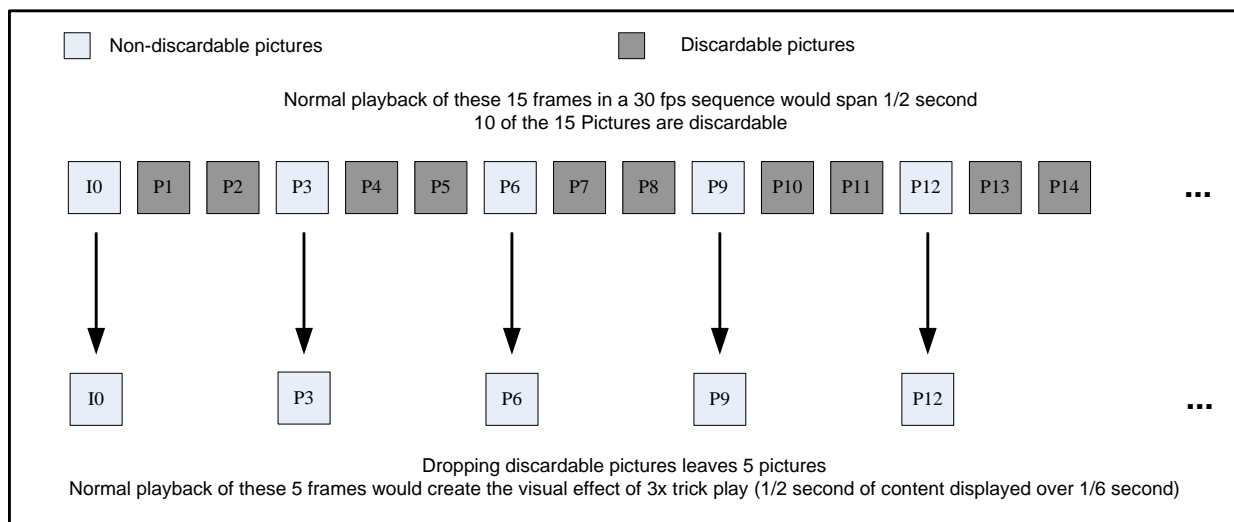

**Figure F.3: Coding Structure with 2 Out of Every 3 Pictures as Discardable Pictures
(The Discardable Pictures Are Inserted Consistently)**

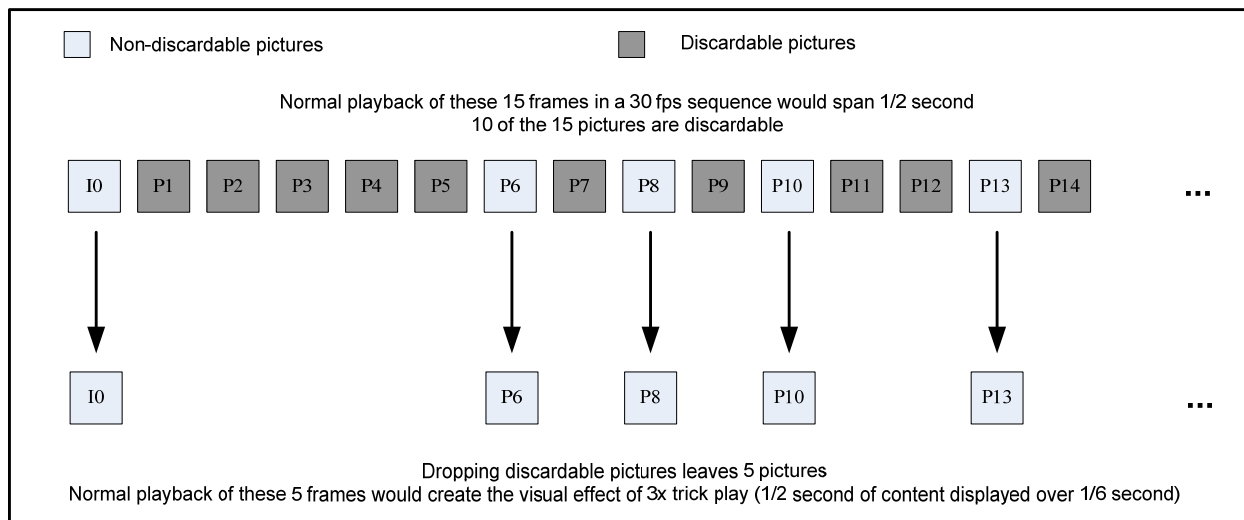

**Figure F.4: Coding Structure with 10 out of Every 15 Pictures as Discardable Pictures
The Discardable Pictures Are Not Inserted Consistently)**

F.2.5 Impact of Adaptive Encoding on Guidelines

It is well known that greater compression efficiency can be achieved by encoders that are able to dynamically adapt to content. This adaptation may occur in the middle of encoding a H.264/AVC GOP, especially with real-time encoders. For this reason, it is often difficult for an encoder to forecast a resulting property of the H.264/AVC GOP such as the number of discardable pictures in a H.264/AVC GOP before it actually encodes the H.264/AVC GOP since it may decide to change its methodology while encoding the H.264/AVC GOP. On the other hand, there is typically a general encoding methodology that will be used if the content being encoded is not drastically different from what the encoder is expecting.

Annex G (informative): Bibliography

ITU-R Recommendation BT.470: "Conventional Television Systems" (Note: This document only references Systems B, G, and I).

ETSI TR 101 162: "Digital broadcasting systems for television, sound and data services; Allocation of Service Information (SI) codes for Digital Video Broadcasting (DVB) systems".

CEI/IEC 61883-1: "Consumer audio/video equipment - Digital interface - Part 1: General".

CEI/IEC 61883-2: "Consumer audio/video equipment - Digital interface - Part 2: SD-SVCR data transmission".

CEI/IEC 61883-3: "Consumer audio/video equipment - Digital interface - Part 3: HD-DVCR data transmission".

CEI/IEC 61883-4: "Consumer audio/video equipment - Digital interface - Part 4: MPEG2-TS data transmission".

SMPTE 125M, "Component Video Signal 4:2:2 - Bit-Parallel Digital Interface"

SMPTE 170M, "Composite Analog Video Signal - NTSC for Studio Applications"

SMPTE 267M, "Bit-Parallel Digital Interface - Component Video Signal 4:2:2 16x9 Aspect Ratio"

SMPTE 274M, "1920 x 1080 Image Sample Structure, Digital Representation and Digital Timing Reference Sequences for Multiple Picture Rates"

SMPTE 293M, "720 x 483 Active Line at 59.94-Hz Progressive Scan Production - Digital Representation"

SMPTE 296M, "1280 x 720 Progressive Image Sample Structure - Analog and Digital Representation and Analog Interface"

ITU-R Recommendation BT.1358 (1998): "Studio parameters of 625 and 525 line progressive scan television systems"