

26 October 2005

AGREEMENT

CONCERNING THE ADOPTION OF UNIFORM TECHNICAL PRESCRIPTIONS FOR WHEELED VEHICLES, EQUIPMENT AND PARTS WHICH CAN BE FITTED AND/OR BE USED ON WHEELED VEHICLES AND THE CONDITIONS FOR RECIPROCAL RECOGNITION OF APPROVALS GRANTED ON THE BASIS OF THESE PRESCRIPTIONS */

(Revision 2, including the amendments which entered into force on 16 October 1995)

Addendum 36: Regulation No. 37

Revision 4

Incorporating all valid text up to:

Supplement 21 to the 03 series of amendments - Date of entry into force: 4 December 2001

Supplement 22 to the 03 series of amendments - Date of entry into force: 7 December 2002

Corrigendum 1 to Revision 3 of the Regulation, subject of Depositary Notification

C.N.32.2003.TREATIES-1 dated 17 January 2003

Supplement 23 to the 03 series of amendments - Date of entry into force: 26 February 2004

Supplement 24 to the 03 series of amendments - Date of entry into force: 13 November 2004

Supplement 25 to the 03 series of amendments - Date of entry into force: 23 June 2005

UNIFORM PROVISIONS CONCERNING THE APPROVAL OF FILAMENT LAMPS FOR USE IN APPROVED LAMP UNITS ON POWER-DRIVEN VEHICLES AND OF THEIR TRAILERS



UNITED NATIONS

*/ Former title of the Agreement:

Agreement Concerning the Adoption of Uniform Conditions of Approval and Reciprocal Recognition of Approval for Motor Vehicle Equipment and Parts, done at Geneva on 20 March 1958.

Regulation No. 37

UNIFORM PROVISIONS CONCERNING THE APPROVAL OF FILAMENT LAMPS
FOR USE IN APPROVED LAMP UNITS ON POWER-DRIVEN VEHICLES
AND OF THEIR TRAILERS

CONTENTS

REGULATION		<u>Page</u>
1.	Scope	5
2.	Administrative provisions	5
2.1.	Definitions	5
2.2.	Application for approval	5
2.3.	Inscriptions	6
2.4.	Approval.....	7
3.	Technical requirements	8
3.1.	Definitions	8
3.2.	General specifications	9
3.3.	Manufacture	9
3.4.	Tests	9
3.5.	Filament position and dimensions.....	10
3.6.	Colour.....	11
3.7.	UV radiation	12
3.8.	Observation concerning selective-yellow colour	12
3.9.	Check on optical quality.....	13
3.10.	Standard filament lamps.....	14
4.	Conformity of production.....	14
5.	Penalties for non-conformity of production	15
6.	Production definitely discontinued.....	16
7.	Names and addresses of technical services responsible for conducting approval tests, and of administrative departments.....	16
8.	Transitional provisions	16

CONTENTS (continued)

ANNEXES

Annex 1: Sheets for filament lamps

Annex 2: Communication concerning the approval or extension or refusal or withdrawal of approval or production definitely discontinued of a type of filament lamp pursuant to Regulation No. 37

Annex 3: Example of the arrangement of the approval mark

Annex 4: Luminous centre and shapes of filament lamps

Annex 5: Checking the colour of filament lamps

Annex 6: Minimum requirements for quality procedures by the manufacturer

Annex 7: Sampling and compliance levels for manufacturer test records

Annex 8: Minimum requirements for spot checks by the administrative authority

Annex 9: Compliance approved by spot check

1. SCOPE

This Regulation applies to filament lamps shown in Annex 1 and intended for use in approved lamp units of power-driven vehicles and of their trailers.

2. ADMINISTRATIVE PROVISIONS

2.1. Definitions

2.1.1. Definition of "category"

The term "category" is used in this Regulation to describe different basic design of standardised filament lamps. Each category has a specific designation, as for example: "H4", "P21W", "T4W".

2.1.2. Definition of "type"

Filament lamps of different "types" are filament lamps within the same category which differ in such essential respects as:

2.1.2.1. trade name or mark; 1/

2.1.2.2. bulb design, in so far as these differences affect the optical results;

2.1.2.3. bulb colour

A selective-yellow bulb or an additional selective-yellow outer bulb, solely intended to change the colour but not the other characteristics of a filament lamp emitting white light, does not constitute a change of type of the filament lamp;

2.1.2.4. rated voltage;

2.1.2.5. halogen.

2.2. Application for approval

2.2.1. Application for approval shall be submitted by the owner of the trade name or mark, or by his duly accredited representative.

2.2.2. Every application for approval shall be accompanied (see also paragraph 2.4.2.) by:

2.2.2.1. drawings in triplicate, sufficiently detailed to permit identification of the type;

1/ Filament lamps bearing the same trade name or mark but produced by different manufacturers are considered as being of different types. Filament lamps produced by the same manufacturer differing only by the trade name or mark may be considered to be of the same type.

- 2.2.2.2. a brief technical description;
- 2.2.2.3. five samples of each colour which has been applied for;
- 2.2.3. In the case of a type of filament lamp differing only by the trade name or mark from a type that has already been approved it shall be sufficient to submit:
 - 2.2.3.1. a declaration by the manufacturer that the type submitted is identical (except in the trade name or mark) with and has been produced by the same manufacturer as, the type already approved, the latter being identified by its approval code;
 - 2.2.3.2. two samples bearing the new trade name or mark.
- 2.2.4. The competent authority shall verify the existence of satisfactory arrangements for ensuring effective control of the conformity of production before type approval is granted.
- 2.3. Inscriptions
 - 2.3.1. Filament lamps submitted for approval shall bear on the cap or bulb: 2/
 - 2.3.1.1. the trade name or mark of the applicant;
 - 2.3.1.2. the rated voltage. However, for filament lamps for which only a 12 V type is standardised and the maximum allowed bulb diameter of which does not exceed 7.5 mm, the rated voltage need not be marked;
 - 2.3.1.3. the international designation of the relevant category. The wattage character "W" of this designation need not be marked when the maximum allowed bulb diameter of the filament lamp type does not exceed 7.5 mm;
 - 2.3.1.4. the rated wattage (in the sequence, high wattage/low wattage filament for dual-filament lamps); this need not be indicated separately if it is part of the international designation of the relevant filament lamp category;
 - 2.3.1.5. a space of sufficient size to accommodate the approval mark.
 - 2.3.2. The space mentioned in paragraph 2.3.1.5. above shall be indicated in the drawings accompanying the application for approval.
 - 2.3.3. Halogen filament lamps meeting the requirements of paragraph 3.7. below shall be marked with a "U".

2/ In the latter case, the luminous characteristics shall not be adversely affected.

2.3.4. Inscriptions other than those covered by paragraphs 2.3.1. and 2.4.3. may be affixed, on the condition that they do not adversely affect the luminous characteristics.

2.4. Approval

2.4.1. If all samples of a type of filament lamp which are submitted in pursuance of paragraphs 2.2.2.3. or 2.2.3.2. above meet the requirements of this Regulation, approval shall be granted.

2.4.2. An approval code shall be assigned to each type approved. Its first character (at present 2, corresponding to the 02 series of amendments which entered into force on 27 October 1983 and to the 03 series of amendments (not requiring changes in the approval number), which entered into force on 1 June 1984) shall indicate the series of amendments incorporating the most recent major technical amendments made to the Regulation at the time of issue of the approval. This will be followed by an identification code comprising not more than two characters. Only the Arabic numerals and capital letters listed in footnote 3/ shall be used. The same Contracting Party may not assign the same code to another type of filament lamp. Notice of approval or of extension or refusal or withdrawal of approval or production definitely discontinued of a type of filament lamp pursuant to this Regulation shall be communicated to the Parties of the Agreement which apply this Regulation by means of a form conforming to the model in Annex 2 to this Regulation and of a drawing, supplied by the applicant for approval in a format not exceeding A4 (210 x 297 mm) and on a scale of at least 2 : 1. If the applicant so desires, the same approval code may be assigned to the filament lamp emitting white light and to the filament lamp emitting selective-yellow light (see para. 2.1.2.3.).

2.4.3. To every filament lamp conforming to a type approved under this Regulation there shall be affixed in the space referred to in paragraph 2.3.1.5., in addition to the inscriptions required under paragraph 2.3.1., an international approval mark consisting of:

3/ 0 1 2 3 4 5 6 7 8 9
A B C D E F G H J K L M N P R S T U V W X Y Z

- 2.4.3.1. a truncated circle surrounding the letter "E" followed by the distinguishing number of the country which has granted approval; 4/
- 2.4.3.2. the approval code, placed close to the truncated circle.
- 2.4.4. If the applicant has obtained the same approval code for several trade names or marks, one or more of them will suffice to meet the requirements of paragraph 2.3.1.1.
- 2.4.5. The marks and inscriptions specified in paragraphs 2.3.1. and 2.4.3. shall be clearly legible and be indelible.
- 2.4.6. Annex 3 to this Regulation gives an example of arrangement of the approval mark.

3. TECHNICAL REQUIREMENTS

3.1. Definitions

- 3.1.1. Rated voltage: voltage (in volts) marked on the filament lamp;
- 3.1.2. Rated wattage: wattage (in watts) marked on the filament lamp which may be incorporated into the international designation of the relevant category;
- 3.1.3. Test voltage: voltage, at the filament lamp terminals for which the electrical and photometric characteristics of the filament lamp are intended and are to be tested.
- 3.1.4. Objective values: values to be achieved, within the specified tolerances, when the filament lamp is supplied with current at its test voltage;

4/ 1 for Germany, 2 for France, 3 for Italy, 4 for the Netherlands, 5 for Sweden, 6 for Belgium, 7 for Hungary, 8 for the Czech Republic, 9 for Spain, 10 for Serbia and Montenegro, 11 for the United Kingdom, 12 for Austria, 13 for Luxembourg, 14 for Switzerland, 15 (vacant), 16 for Norway, 17 for Finland, 18 for Denmark, 19 for Romania, 20 for Poland, 21 for Portugal, 22 for the Russian Federation, 23 for Greece, 24 for Ireland, 25 for Croatia, 26 for Slovenia, 27 for Slovakia, 28 for Belarus, 29 for Estonia, 30 (vacant), 31 for Bosnia and Herzegovina, 32 for Latvia, 33 (vacant), 34 for Bulgaria, 35 (vacant), 36 for Lithuania, 37 for Turkey, 38 (vacant), 39 for Azerbaijan, 40 for The former Yugoslav Republic of Macedonia, 41 (vacant), 42 for the European Community (Approvals are granted by its Member States using their respective ECE symbol), 43 for Japan, 44 (vacant), 45 for Australia, 46 for Ukraine, 47 for South Africa, 48 for New Zealand, 49 for Cyprus, 50 for Malta and 51 for the Republic of Korea. Subsequent numbers shall be assigned to other countries in the chronological order in which they ratify or accede to the Agreement Concerning the Adoption of Uniform Technical Prescriptions for Wheeled Vehicles, Equipment and Parts which can be Fitted and/or be Used on Wheeled Vehicles and the Conditions for Reciprocal Recognition of Approvals Granted on the Basis of these Prescriptions, and the numbers thus assigned shall be communicated by the Secretary-General of the United Nations to the Contracting Parties to the Agreement.

- 3.1.5. Standard (étalon) filament lamp: a filament lamp emitting white or amber or red light with reduced dimensional tolerances, used for the photometric testing of lighting and light-signalling devices. Standard filament lamps are specified in only one voltage rating for each category;
- 3.1.6. Reference luminous flux: specified luminous flux of a standard filament lamp to which the optical characteristics of a lighting device shall be referred;
- 3.1.7. Measuring luminous flux: specified value of the luminous flux for testing a filament lamp in a standard headlamp as specified in paragraph 3.8.;
- 3.1.8. Reference axis: an axis defined with reference to the cap and to which certain dimensions of the filament lamp are referred;
- 3.1.9. Reference plane: a plane defined with reference to the cap and to which certain dimensions of the filament lamp are referred.
- 3.2. General specifications
- 3.2.1. Each sample submitted shall conform to the relevant specifications of this Regulation.
- 3.2.2. Filament lamps shall be so designed as to be and to remain in good working order when in normal use. They shall moreover exhibit no fault in design or manufacture.
- 3.3. Manufacture
- 3.3.1. Filament lamp bulbs shall exhibit no scores or spots which might impair their efficiency and their optical performance.
- 3.3.2. Filament lamps shall be equipped with standard caps complying with the cap data sheets of IEC Publication 60061, third edition, as specified on the individual data sheets of Annex 1.
- 3.3.3. The cap shall be strong and firmly secured to the bulb.
- 3.3.4. To ascertain whether filament lamps conform to the requirements of paragraphs 3.3.1. to 3.3.3. above, a visual inspection, a dimension check and, where necessary, a trial fitting shall be carried out.
- 3.4. Tests
- 3.4.1. Filament lamps shall first be aged at their test voltage for approximately one hour. For dual-filament lamps, each filament shall be aged separately.

- 3.4.2. In the case of a filament lamp having a coated bulb, after the ageing period corresponding to paragraph 3.4.1., the surface of the bulb shall be lightly wiped with a cotton cloth soaked in a mixture of 70 vol. per cent of n-heptane and 30 vol. per cent of toluol. After about five minutes, the surface shall be inspected visually. It shall not show any apparent changes.
- 3.4.3. The position and dimensions of the filament shall be measured with the filament lamps being supplied with current at from 90 per cent to 100 per cent of the test voltage.
- 3.4.4. Unless otherwise specified, electrical and photometric measurements shall be carried out at the test voltage.
- 3.4.5. Electrical measurements shall be carried out with instruments of at least class 0.2.
- 3.4.6. The luminous flux (in lumen) specified on the filament lamp data sheets of Annex 1 is valid for filament lamps emitting white light unless a special colour is stated there.

In the case where the selective-yellow colour is allowed, the luminous flux of the filament lamp with the selective-yellow outer bulb shall be at least 85 per cent of the specified luminous flux of the relevant filament lamp emitting white light.

3.5. Filament position and dimensions

- 3.5.1. The geometric shapes of the filament shall in principle be as specified on the filament lamp data sheets of Annex 1.
- 3.5.2. For line filaments the correct position and shape shall be checked as specified in the relevant data sheets.
- 3.5.3. If the filament is shown on the filament lamp data sheet in at least one view as a point, the position of the luminous centre shall be determined in conformity with Annex 4.
- 3.5.4. The length of a line filament shall be determined by its ends, defined - unless otherwise specified on the relevant data sheet - as the apices of the first and the last filament turn as seen in projection perpendicular to the reference axis of the filament lamp. Such an apex shall comply with the requirement that the angle formed by the legs shall not exceed 90°. In the case of coiled-coil filaments the apices of the secondary turns shall be taken into account.
- 3.5.4.1. For axial filaments the extreme position of the apices considered shall be determined by rotating the filament lamp about its reference axis. The length shall then be measured in a direction parallel to the reference axis.

3.5.4.2. For transverse filaments the filament axis shall be placed perpendicular to the direction of projection. The length shall be measured in a direction perpendicular to the reference axis.

3.6. Colour

3.6.1. The colour of the light emitted by the filament lamp shall be white unless otherwise specified on the relevant data sheet.

3.6.2. The colourimetric characteristics of the light emitted, expressed in CIE trichromatic coordinates, shall lie within the following limits:

finished filament lamps emitting white light:

limit towards blue:	$x \geq 0.310$
limit towards yellow:	$x \leq 0.500$
limit towards green:	$y \leq 0.150 + 0.640 x$
limit towards green:	$y \leq 0.440$
limit towards purple:	$y \geq 0.050 + 0.750 x$
limit towards red:	$y \geq 0.382;$

finished filament lamps emitting selective-yellow light:

limit towards red:	$y \geq 0.138 + 0.580 x$
limit towards green:	$y \leq 1.290 x - 0.100$
limit towards white:	$y \geq 0.966 - x$ ($y \geq 0.940 - x$ and $y = 0.440$ for front fog lamps)
limit towards spectral value:	$y \leq 0.992 - x;$

finished filament lamps emitting amber light:

limit towards green:	$y \leq x - 0.120$
limit towards red:	$y \geq 0.390$
limit towards white:	$y \geq 0.790 - 0.670 x;$

finished filament lamps emitting red light:

limit towards yellow:	$y \leq 0.335$
limit towards purple:	$y \geq 0.980 - x.$

3.6.3. The colour of the light emitted shall be measured by the method specified in Annex 5. Each measured value shall lie within the required tolerance area. 5/ Moreover, in the

5/ For Conformity of Production purposes and for amber and red colour only, at least 80 per cent of the measuring results shall lie within the required tolerance area.

case of filament lamps emitting white light, the measured values shall not deviate more than 0.020 units in the x and/or y direction from a point of choice on the Planckian locus (IEC Publication 15.2 Colorimetry, 1986). Filament lamps for use in light signalling devices shall meet the requirements as specified in paragraph 2.4.2. of IEC Publication 60809, Amendment 3 to Edition 2.

3.7. UV radiation

The UV radiation of a halogen lamp shall be such that:

$$k_1 = \frac{\int_{\lambda=315nm}^{400nm} E_e(\lambda) \cdot d\lambda}{683 \int_{\lambda=380nm}^{780nm} E_e(\lambda) \cdot V(\lambda) \cdot d\lambda} \leq 2 \times 10^{-4} \quad W/lm$$

$$k_2 = \frac{\int_{\lambda=250nm}^{315nm} E_e(\lambda) \cdot d\lambda}{683 \int_{\lambda=380nm}^{780nm} E_e(\lambda) \cdot V(\lambda) \cdot d\lambda} \leq 2 \times 10^{-6} \quad W/lm$$

where:

- $E_e(\lambda)$ [W/nm] is the spectral distribution of the radiant flux;
- $V(\lambda)$ [1] is the spectral luminous efficiency;
- λ [nm] is the wave length.

This value shall be calculated using intervals of five nanometres.

3.8. Observation concerning selective-yellow colour

An approval of a filament lamp type under this Regulation may be granted, pursuant to paragraph 3.6. above, for a filament lamp emitting white light as well as selective-yellow light; Article 3 of the Agreement to which this Regulation is annexed shall not prevent the Contracting Parties from prohibiting, on vehicles registered by them, filament lamps emitting either white or selective-yellow light.

3.9. Check on optical quality

(Applies only to filament lamps of categories R2, H4 and HS1).

3.9.1. This check on optical quality shall be carried out at a voltage such that the measuring luminous flux is obtained; the specifications of paragraph 3.4.6. are to be observed accordingly.

3.9.2. For 12-Volt filament lamps emitting white light:

The sample which most nearly conforms to the requirements laid down for the standard filament lamp shall be tested in a standard headlamp as specified in paragraph 3.9.5. and it shall be verified whether the assembly comprising the aforesaid headlamp and the filament lamp being tested meets the light-distribution requirements laid down for the passing-beam in the relevant Regulation.

3.9.3. For 6-Volt and 24-Volt filament lamps emitting white light:

The sample which most nearly conforms to the nominal dimension values shall be tested in a standard headlamp as specified in paragraph 3.9.5. and it shall be verified whether the assembly comprising the aforesaid headlamp and the filament lamp being tested meets the light-distribution requirements laid down for the passing-beam in the relevant Regulation. Deviations not exceeding 10 per cent of the minimum values will be acceptable.

3.9.4. Filament lamps emitting selective-yellow light shall be tested in the same manner as described in paragraphs 3.9.2. and 3.9.3. in a standard headlamp as specified in paragraph 3.9.5. to ensure that the illumination complies with at least 85 per cent for 12-Volt filament lamps, and at least 77 per cent for 6-Volt and 24-Volt filament lamps, with the minimum values of the light-distribution requirements laid down for the passing-beam in the relevant Regulation. The maximum illumination limits remain unchanged.

In the case of a filament lamp having a selective-yellow bulb, this test shall be left out if the approval is also given to the same type of filament lamp emitting white light.

3.9.5. A headlamp shall be deemed to be a standard headlamp if:

3.9.5.1. it satisfies the pertinent conditions of approval;

3.9.5.2. it has an effective diameter of not less than 160 mm;

3.9.5.3. with a standard filament lamp it produces at the various points and in the various zones specified for the headlamp type concerned, illumination equal to:

3.9.5.3.1. not more than 90 per cent of the maximum limits;

3.9.5.3.2. not less than 120 per cent of the minimum limits prescribed for the headlamp type concerned.

3.10. Standard filament lamps

Additional requirements for standard (étalon) filament lamps are given on the relevant data sheets of Annex 1.

Bulbs of standard (étalon) filament lamps emitting white light shall not alter the CIE trichromatic coordinates of a luminous source having a colour temperature of 2,856 K by more than 0.010 units in the x and/or y direction.

For standard (étalon) filament lamps emitting amber or red light, changes of the bulb temperature shall not affect the luminous flux which might impair photometric measurements of signalling devices.

4. CONFORMITY OF PRODUCTION

4.1. Filament lamps approved to this Regulation shall be so manufactured as to conform to the type approved by meeting the inscriptions and technical requirements set forth in paragraph 3. above and Annexes 1, 3 and 4 to this Regulation.

4.2. In order to verify that the requirements of paragraph 4.1. are met, suitable controls of the production shall be carried out.

4.3. The holder of the approval shall in particular:

4.3.1. ensure existence of procedures for the effective control of the quality of products,

4.3.2. have access to the control equipment necessary for checking the conformity to each approved type,

4.3.3. ensure that data of test results are recorded and that related documents shall remain available for a period to be determined in accordance with the administrative service,

4.3.4. analyse the results of each type of test, applying criteria of Annex 7, in order to verify and ensure the stability of the product characteristics making allowance for variation of an industrial production,

4.3.5. ensure that for each type of filament lamp, at least the tests prescribed in Annex 6 to this Regulation are carried out,

- 4.3.6. ensure that any collecting of samples giving evidence of non-conformity with the type of test considered shall give rise to another sampling and another test. All the necessary steps shall be taken to re-establish the conformity of the corresponding production.
- 4.4. The competent authority which has granted type-approval may at any time verify the conformity control methods applicable to each production unit.
- 4.4.1. In every inspection, the test books and production survey records shall be presented to the visiting inspector.
- 4.4.2. The inspector may take samples at random which will be tested in the manufacturer's laboratory. The minimum number of samples may be determined according to the results of the manufacturer's own verification.
- 4.4.3. When the quality level appears unsatisfactory or when it seems necessary to verify the validity of the tests carried out in application of paragraph 4.4.2. above, the inspector shall select samples, to be sent to the technical service which has conducted the type approval tests.
- 4.4.4. The competent authority may carry out any tests prescribed in this Regulation. Where the competent authority decides to carry out spot checks, criteria of Annexes 8 and 9 to this Regulation shall be applied.
- 4.4.5. The normal frequency of inspection authorised by the competent authority shall be one every two years. In the case where negative results are recorded during one of these visits, the competent authority shall ensure that all necessary steps are taken to re-establish the conformity of production as rapidly as possible.
5. PENALTIES FOR NON-CONFORMITY OF PRODUCTION
- 5.1. The approval granted in respect of a filament lamp pursuant to this Regulation may be withdrawn if the requirements are not met or if a filament lamp bearing the approval mark does not conform to the type approved.
- 5.2. If a Contracting Party to the Agreement applying this Regulation withdraws an approval it has previously granted, it shall forthwith so notify the other Contracting Parties applying this Regulation, by means of a communication form conforming to the model in Annex 2 to this Regulation.

6. PRODUCTION DEFINITELY DISCONTINUED

If the holder of the approval completely ceases to manufacture a type of filament lamp approved in accordance with this Regulation, he shall so inform the authority which has granted the approval. Upon receiving the relevant communication, that authority shall inform thereof the other Parties to the 1958 Agreement applying this Regulation by means of a communication form conforming to the model in Annex 2 to this Regulation.

7. NAMES AND ADDRESSES OF THE TECHNICAL SERVICES RESPONSIBLE FOR CONDUCTING APPROVAL TESTS, AND OF ADMINISTRATIVE DEPARTMENTS

The Parties to the 1958 Agreement which apply this Regulation shall communicate to the United Nations secretariat the names and addresses of the technical services responsible for conducting approval tests and of the administrative departments which grant approval and to which forms certifying approval or extension or refusal or withdrawal of approval, or production definitely discontinued issued in other countries, are to be sent.

8. TRANSITIONAL PROVISIONS

- 8.1. Approvals granted under the preceding series of amendments shall remain valid, except that for conformity of production, current production filament lamps shall comply with the requirements of the latest series of amendments starting 12 months from the date of application of this amendment. 6/

6/ The amended text of this paragraph was introduced by Supplement 14 to the 03 series of amendments. This supplement entered into force on 3 September 1997 and it also introduced in the text of the Regulation new paragraphs 2.3.3. and 3.7. and in Annex 1 new sheets HIR1 and PY27/7W.

8.2. The correspondence between the former designations and the new ones is indicated in the following table:

Old designations	New designations in the 03 series of amendments
P25-1	P21W
P25-2	P21/5W
R19/5	R5W
R19/10	R10W
C11	C5W
C15	C21W
T8/4	T4W
W10/5	W5W
W10/3	W3W

Annex 1

SHEETS */ FOR FILAMENT LAMPS

List of categories of filament lamps and their sheet numbers:

<u>Category</u>	<u>Sheet number(s)</u>
H1	H1/1 to 3
H3	H3/1 to 4
H4	H4/1 to 5
H7	H7/1 to 4
H8	H8/1 to 4
H8B	H8/1 to 4
H9	H9/1 to 4
H9B	H9/1 to 4
H10	H10/1 to 3
H11	H11/1 to 4
H11B	H11/1 to 4
H12	H12/1 to 3
H13	H13/1 to 4
H13A	H13/1 to 4
H14	H14/1 to 4
H27W/1	H27W/1 to 3
H27W/2	H27W/1 to 3
HB3	HB3/1 to 4
HB3A	HB3/1 to 4
HB4	HB4/1 to 4
HB4A	HB4/1 to 4
HIR1	HIR1/1 to 3
HIR2	HIR2/1 to 3
HS1	HS1/1 to 5
HS2	HS2/1 to 3
HS5	HS5/1 to 4
R2	R2/1 to 3
S1	S1/S2/1 to 2
S2	S1/S2/1 to 2
S3	S3/1

*/ Tables, Electrical and Photometric characteristics:

Voltage is expressed in V;

Wattage is expressed in W;

Luminous flux is expressed in lm.

Category	Sheet number(s)
only for signalling lamps:	
C5W	C5W/1
C21W	C21W/1 to 2
H6W	H6W/1
H21W	H21W/1 to 2
P13W	P13W/1 to 3
P19W	P19W/1 to 3
P21W	P21W/1 to 2
P21/4W	P21/4W/1 (P21/5W/2 to 3)
P21/5W	P21/5W/1 to 3
P24W	P24W/1 to 3
P27W	P27W/1 to 2
P27/7W	P27/7W/1 to 3
PR19W	P19W/1 to 3
PR21W	PR21W/1 (P21W/2)
PR21/4W	PR21/4W/1 (P21/5W/2 to 3)
PR21/5W	PR21/5W/1 (P21/5W/2 to 3)
PR24W	P24W/1 to 3
PR27/7W	PR27/7W/1 (P27/7W/2 to 3)
PS19W	P19W/1 to 3
PS24W	P24W/1 to 3
PSR19W	P19W/1 to 3
PSR24W	P24W/1 to 3
PSY19W	P19W/1 to 3
PSY24W	P24W/1 to 3
PY19W	P19W/1 to 3
PY21W	PY21W/1 (P21W/2)
PY24W	P24W/1 to 3
PY27/7W	PY27/7W/1 (P27/7W/2 to 3)
R5W	R5W/1
R10W	R10W/1
RR5W	R5W/1
RR10W	R10W/1
RY10W	R10W/1
T1.4W	T1.4W/1
T4W	T4W/1
W2.3W	W2.3W/1
W3W	W3W/1
W5W	W5W/1
W16W	W16W/1
W21W	W21W/1 to 2
W21/5W	W21/5W/1 to 3
WP21W	WP21W/1 to 2
WPY21W	WPY21W/1 to 2
WR5W	W5W/1

<u>Category</u>	<u>Sheet number(s)</u>
WR21/5W	WR21/5W/1 (W21/5W/2 to 3)
WY2.3W	WY2.3W/1
WY5W	W5W/1
WY21W	WY21W/1 to 2

List of sheets for filament lamps and their sequence in this annex:

Sheet number(s)

- C5W/1
- C21W/1 to 2
- H1/1 to 3
- H3/1 to 4
- H4/1 to 5
- H7/1 to 4
- H8/1 to 4
- H9/1 to 4
- H10/1 to 3
- H11/1 to 4
- H12/1 to 3
- H13/1 to 4
- H14/1 to 4
- H6W/1
- H21W/1 to 2
- H27W/1 to 3
- HB3/1 to 4
- HB4/1 to 4
- HIR1/1 to 3
- HIR2/1 to 3
- HS1/1 to 5
- HS2/1 to 3
- HS5/1 to 4
- P13W/1 to 3
- P19W/1 to 3
- P21W/1 to 2
- P21/4W/1
- P21/5W/1 to 3
- P24W/1 to 3
- P27W/1 to 2
- P27/7W/1 to 3
- PR21W/1
- PR21/4W/1
- PR21/5W/1
- PR27/7W/1

Sheet number(s)

PY21W/1
PY27/7W/1
R2/1 to 3
R5W/1
R10W/1
S1/S2/1 to 2
S3/1
T1.4W/1
T4W/1
W2.3W/1
W3W/1
W5W/1
W16W/1
W21W/1 to 2
W21/5W/1 to 3
WP21W/1 to 2
WR21/5W/1
WY2.3W/1
WY21W/1 to 2

CATEGORY C5W

Sheet C5W/1

The drawings are intended only to illustrate the essential dimensions (in mm) of the filament lamp

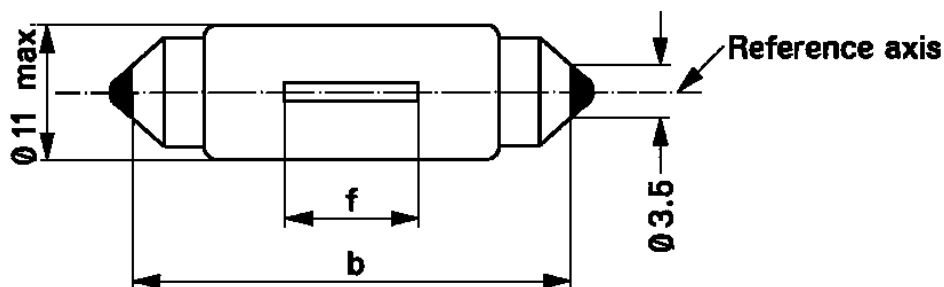

Dimensions in mm	Filament lamps of normal production			Standard filament lamp	
	min.	nom.	max.		
b <u>1/</u>	34.0	35.0	36.0	35.0 ± 0.5	
f <u>2/ 3/</u>	7.5 <u>4/</u>		15 <u>5/</u>	9 ± 1.5	
Cap SV8.5 in accordance with IEC Publication 60061 (sheet 7004-81-4)					
ELECTRICAL AND PHOTOMETRIC CHARACTERISTICS					
Rated values	Volts	6	12	24	12
	Watts	5			5
Test voltage	Volts	6.75	13.5	28.0	13.5
Objective values	Watts	5.5 max.		7.7 max.	5.5 max.
	Luminous flux	45 \pm 20 %			
Reference luminous flux: 45 lm at approximately 13.5 V					

- 1/ This dimension corresponds to a distance between two apertures of 3.5 mm diameter each bearing against one of the caps.
- 2/ The filament shall be housed in a cylinder 19 mm long co-axial with the filament lamp and placed symmetrically about the filament lamp centre.
The diameter of the cylinder is for 6 V and 12 V filament lamps: $d + 4$ mm (for standard filament lamps: $d + 2$ mm) and for 24 V filament lamps: $d + 5$ mm, "d" being the nominal diameter of the filament as stated by the manufacturer.
- 3/ The deviation of the filament centre from the centre of the filament lamp shall not be more than ± 2.0 mm (for standard filament lamps: ± 0.5 mm) measured in the direction of the reference axis.
- 4/ 4.5 mm for 6 V filament lamps.
- 5/ 16.5 mm for 24 V filament lamps.

CATEGORY C21W

Sheet C21W/1

The drawings are intended only to illustrate the essential dimensions (in mm) of the filament lamp

Filament lamp for reversing lamp only

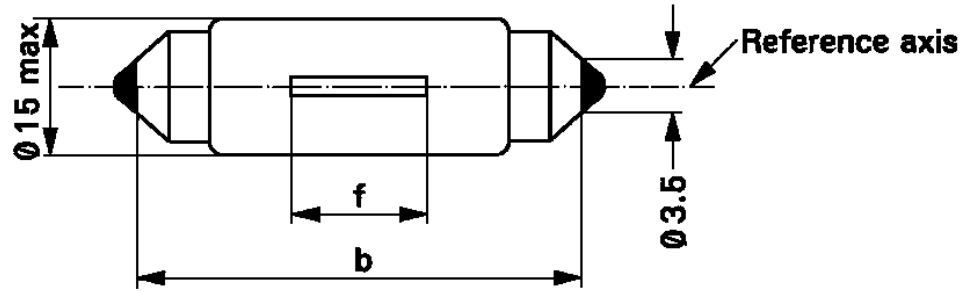

Dimensions in mm		Filament lamps of normal production			Standard filament lamp
		min.	nom.	max.	
b	<u>1/</u>	40.0	41.0	42.0	41.0 ± 0.5
f	<u>2/</u>	7.5		10.5	8 ± 1.0
Cap SV8.5 in accordance with IEC Publication 60061 (sheet 7004-81-4)					
ELECTRICAL AND PHOTOMETRIC CHARACTERISTICS					
Rated values	Volts	12			12
	Watts	21			21
Test voltage	Volts	13.5			13.5
Objective values	Watts	26.5 max.			26.5 max.
	Luminous flux	460 ± 15 %			
Reference luminous flux: 460 lm at approximately 13.5 V					

1/ This dimension corresponds to a distance between two apertures of 3.5 mm diameter.

2/ The position of the filament is checked by means of a "Box-System"; sheet C21W/2.

Screen projection requirements

This test is used to determine, by checking whether the filament is correctly positioned relative to the reference axis and to the centre of the filament lamp's length, whether a filament lamp complies with the requirements.

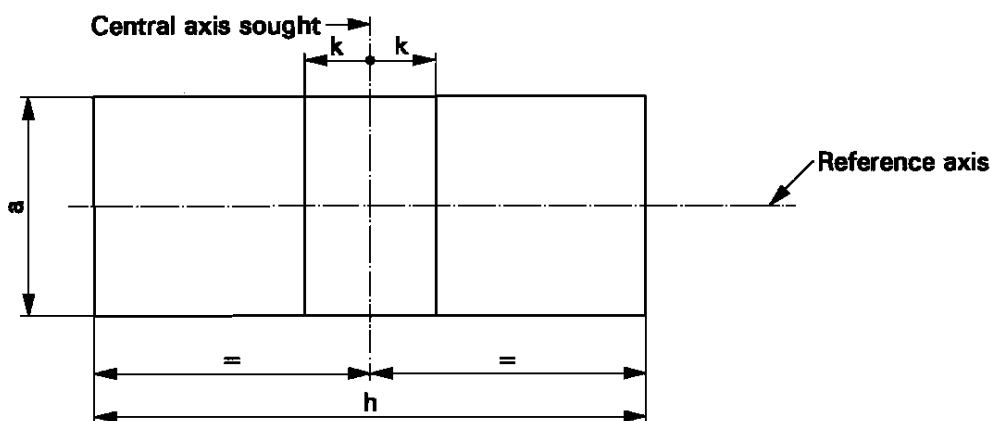

12 V	a	h	k
filament lamps of normal production	4.0 + d	14.5	2.0
standard filament lamp	2.0 + d	14.5	0.5

d = nominal filament diameter as stated by the manufacturer.

Test procedure and requirements.

1. The filament lamp is placed in a holder (socket) capable of being so rotated through 360° about the reference axis that the front elevation is seen on the screen on to which the image of the filament is projected. The reference plane on the screen shall coincide with the centre of the filament lamp. The central axis sought on the screen shall coincide with the centre of the filament lamp length.
2. Front elevation
 - 2.1. The projection of the filament shall lie entirely within the rectangle when the filament lamp is rotated through 360°.
 - 2.2. The centre of the filament shall not be offset by more than distance "k" from the central axis sought.

CATEGORY H1

Sheet H1/1

The drawings are intended only to illustrate the essential dimensions (in mm) of the filament lamp

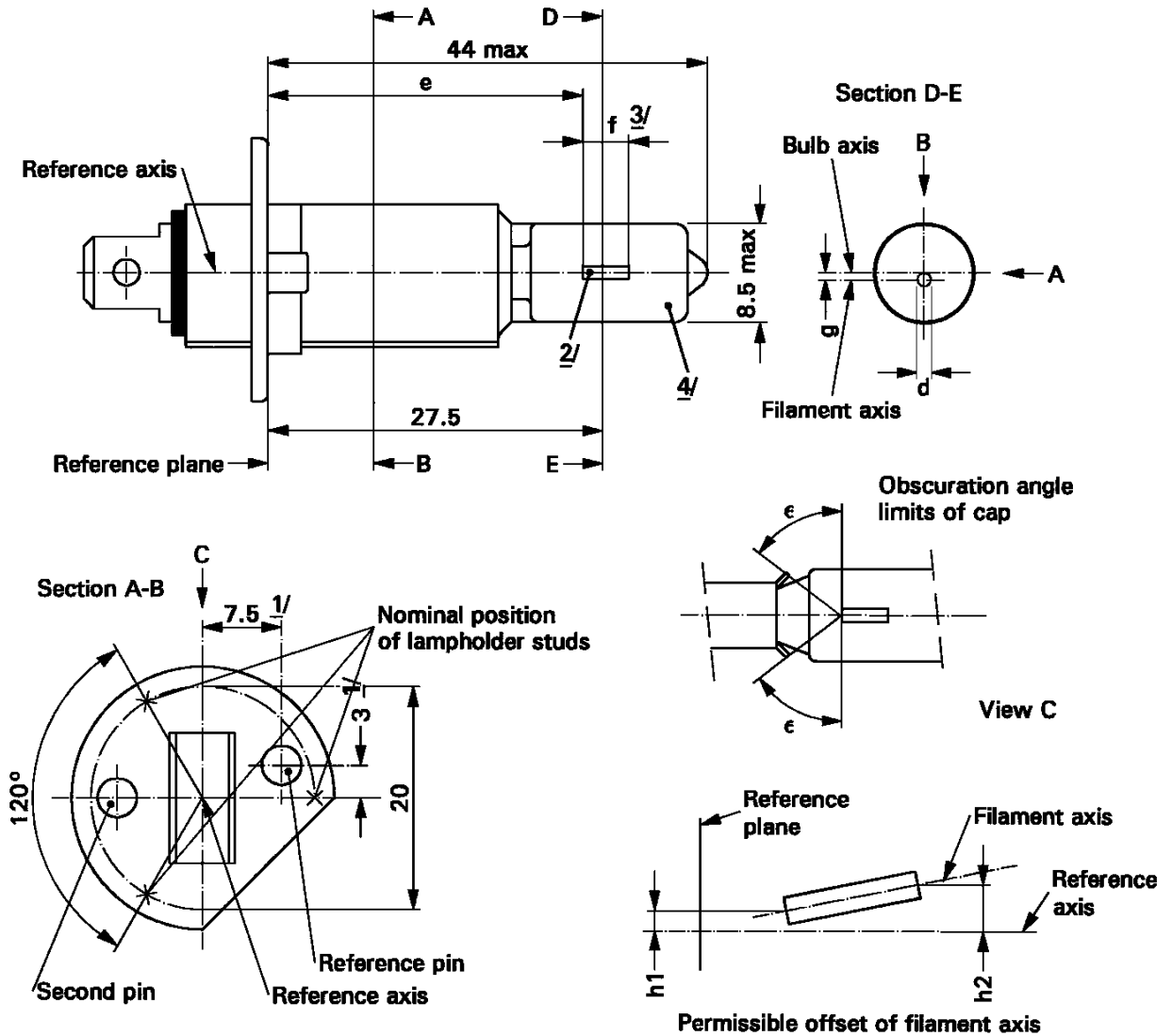

- 1/ The reference axis is perpendicular to the reference plane and passes through the point defined by the dimensions marked with 1/.
- 2/ Both current lead-in electrodes shall be positioned in the bulb, the longer electrode above the filament (the filament lamp being viewed as shown in the figure). The internal design should be then such that stray light images and reflections are reduced to the minimum, e.g. by fitting cooling jackets over the non-coiled parts of the filament.
- 3/ The cylindrical portion of the bulb over length "f" shall be such as not to deform the projected image of the filament to such an extent as appreciably to affect the optical results.
- 4/ The bulb shall be colourless or selective-yellow.

CATEGORY H1

Sheet H1/2

Dimensions in mm	Filament lamps of normal production			Standard filament lamp	
	6 V	12 V	24 V	12 V	
e <u>6/ 10/</u>	25.0 <u>9/</u>			25.0 ± 0.15	
f <u>6/ 10/</u>	4.5 ± 1.0	5.0 ± 0.5	5.5 ± 1.0	5.0 +0.50/-0.00	
g <u>7/ 8/</u>	0.5 d ± 0.5 d			0.5 d ± 0.25 d	
h1	<u>9/</u>			0 ± 0.20 <u>5/</u>	
h2	<u>9/</u>			0 ± 0.25 <u>5/</u>	
ε	45° ± 12°			45° ± 3°	
Cap P14.5s in accordance with IEC Publication 60061 (sheet 7004-46-2)					
ELECTRICAL AND PHOTOMETRIC CHARACTERISTICS					
Rated values	Volts	6	12	24	12
	Watts	55		70	55
Test Voltage	Volts	6.3	13.2	28.0	13.2
Objective values	Watts	63 max.	68 max.	84 max.	68 max.
	Luminous flux	1,350	1,550	1,900	
	± %	15			
Reference luminous flux: 1150 at approximately 12 V					

- 5/ The eccentricity is measured only in the horizontal and vertical directions of the filament lamp as shown in the figure. The points to be measured are those where the projections of the outside of the end turns nearest to or furthest from the reference plane crosses the filament axis.
- 6/ The viewing direction is the perpendicular to the reference axis contained in the plane defined by the reference axis and the centre of the second pin of the cap.
- 7/ Offset of filament in relation to bulb axis measured at 27.5 mm from the reference plane.
- 8/ d: diameter of filament.
- 9/ To be checked by means of a "Box System", sheet H1/3.
- 10/ The ends of the filament are defined as the points where, when the viewing direction is as defined in note 6/ above, the projection of the outside of the end turns nearest to or furthest from the reference plane crosses the reference axis.(special instructions for coiled-coil filaments are under consideration).

CATEGORY H1

Sheet H1/3

Screen projection requirements

This test is used to determine, by checking whether the filament is correctly positioned relative to the reference axis and reference plane, whether a filament lamp complies with the requirements.

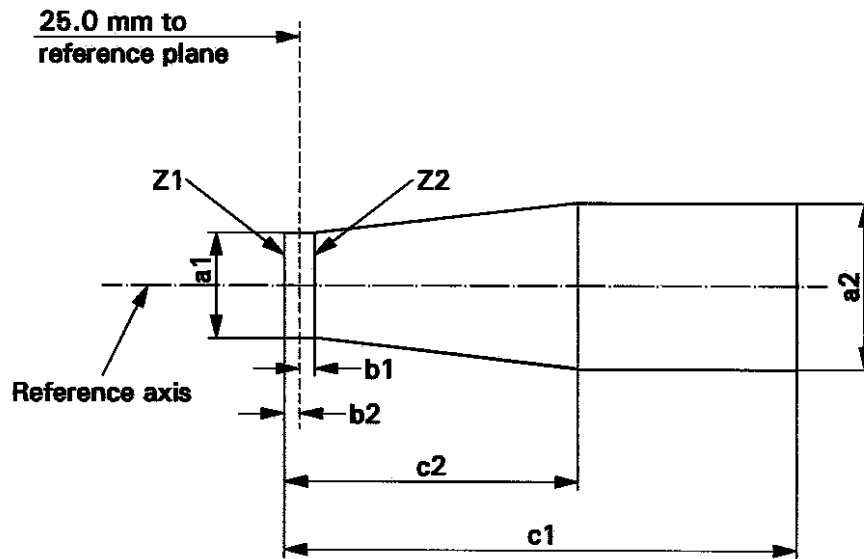

	a1	a2	b1	b2	c1	c2
6 V	1.4d	1.9 d	0.25		6	3.5
12 V					6	4.5
24 V					7	4.5

d = diameter of filament.

The filament position is checked solely in directions A and B as shown on sheet H1/1.

The filament shall lie entirely within the limits shown.

The beginning of the filament as defined on sheet H1/2, note 10/, shall lie between lines Z1 and Z2.

The drawings are intended only to illustrate the essential dimensions (in mm) of the filament lamp

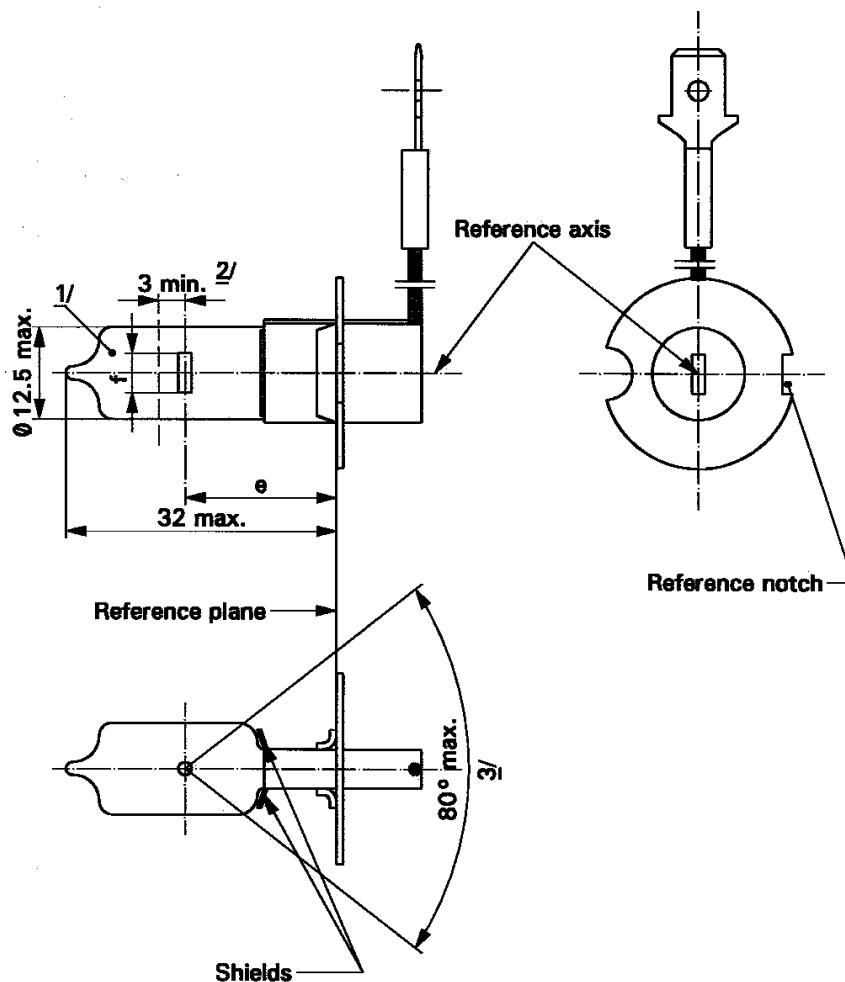

- 1/ Bulb colourless or selective-yellow.
- 2/ Minimum length above the height of the light emitting centre ("e") over which the bulb shall be cylindrical.
- 3/ The distortion of the base-end portion of the bulb shall not be visible from any direction outside the obscuration angle of 80° max. The shields shall produce no inconvenient reflections. The angle between the reference axis and the plane of each shield, measured on the bulb side, shall not exceed 90° .

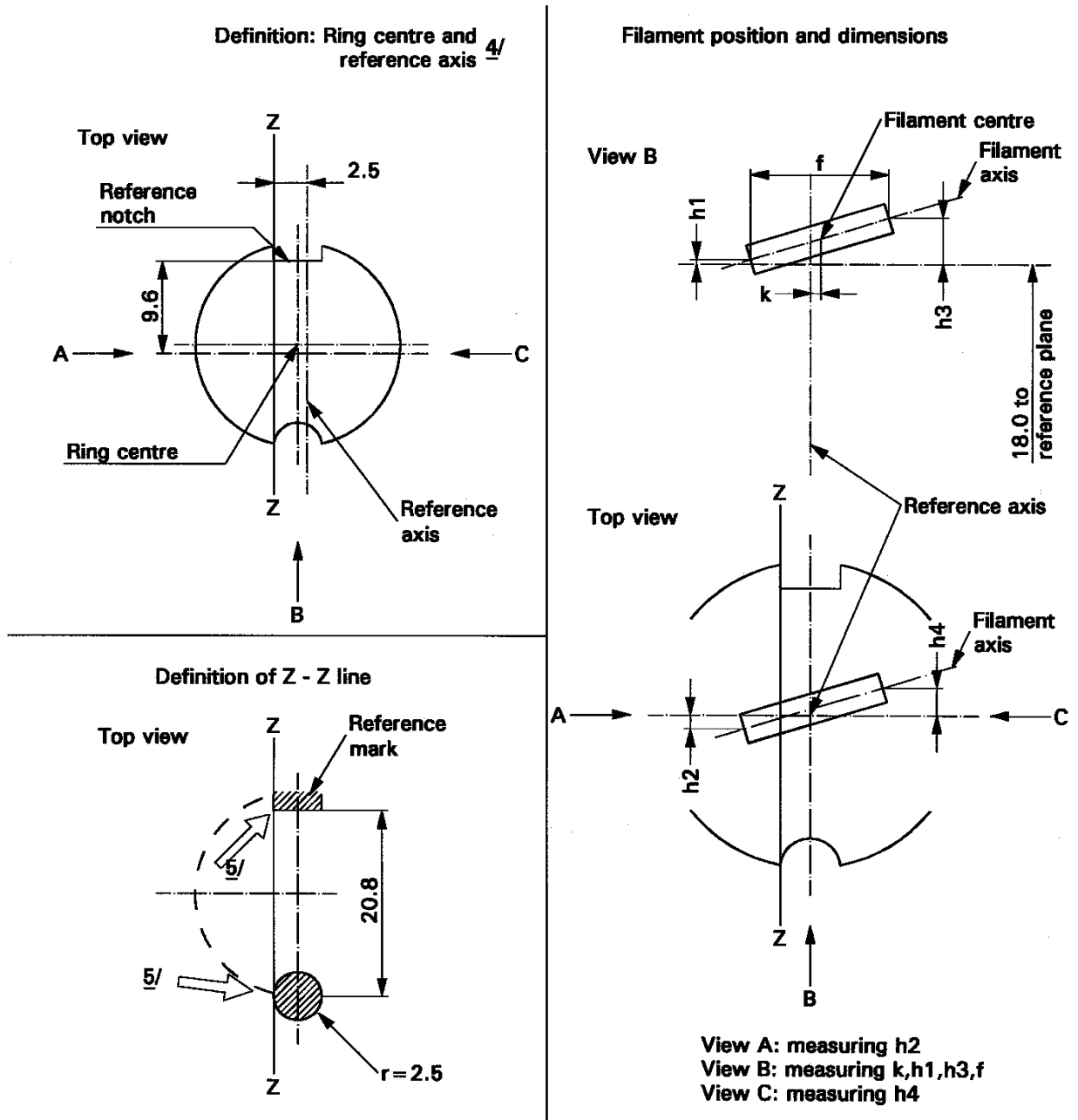

^{4/} The permissible deviation of the ring centre from the reference axis is 0.5 mm in the direction perpendicular to the Z-Z line and 0.05 mm in the direction parallel to the Z-Z line.

^{5/} The cap shall be pressed in these directions.

CATEGORY H3

Sheet H3/3

Dimensions in mm	Filaments lamps of normal production			Standard filament lamp	
	6 V	12 V	24 V	12 V	
e	18.0 <u>6/</u>			18.0	
f <u>8/</u>	3.0 min.	4.0 min.		5.0 ± 0.50	
k	0 <u>6/</u>			0 ± 0.20	
h1, h3	0 <u>6/</u>			0 ± 0.15 <u>7/</u>	
h2, h4	0 <u>6/</u>			0 ± 0.25 <u>7/</u>	
Cap PK22s in accordance with IEC Publication 60061 (sheet 7004-47-4)					
ELECTRICAL AND PHOTOMETRIC CHARACTERISTICS					
Rated values	Volts	6	12	24	12
	Watts	55		70	55
Test voltage	Volts	6.3	13.2	28.0	13.2
Objective values	Watts	63 max.	68 max.	84 max.	68 max.
	Luminous flux ± %	1,050	1,450	1,750	
		15			
Reference luminous flux: 1,100 lm at approximately 12 V					

- 6/ To be checked by means of a "Box-System"; sheet H3/4.
- 7/ For standard filament lamps the points to be measured are those where the projection of the outside of the end turns crosses the filament axis.
- 8/ The positions of the first and the last turn of the filament are defined by the intersections of the outside of the first and of the last light emitting turn, respectively, with the plane parallel to and 18 mm distant from the reference plane. (Additional instructions for coiled-coil filament are under consideration).

CATEGORY H3

Sheet H3/4

Screen projection requirements

This test is used to determine, by checking whether the filament is correctly positioned relative to the reference axis and reference plane, whether a filament complies with the requirements.

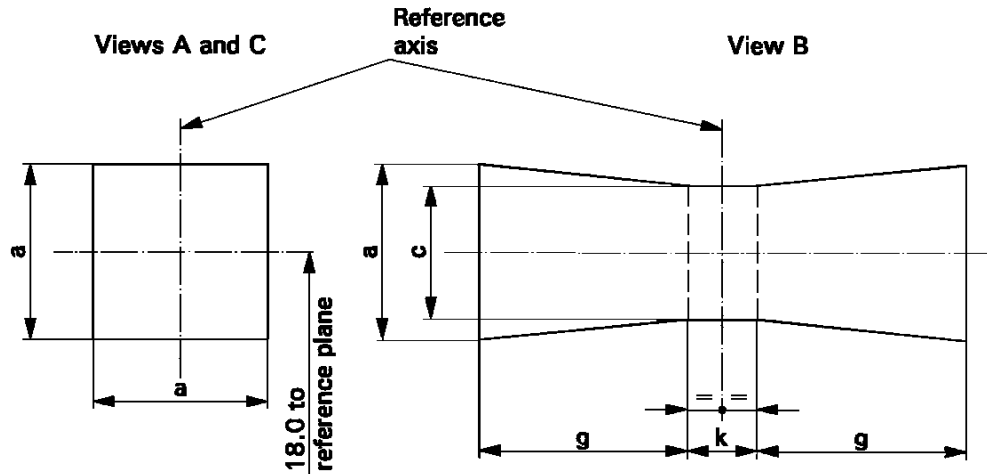

	a	c	k	g
6 V	1.8 d	1.6 d	1.0	2.0
12 V				2.8
24 V				2.9

d = diameter of filament

The filament shall lie entirely within the limits shown.

The centre of the filament shall lie within the limits of dimension k.

The drawings are intended only to illustrate the essential dimensions (in mm) of the filament lamp

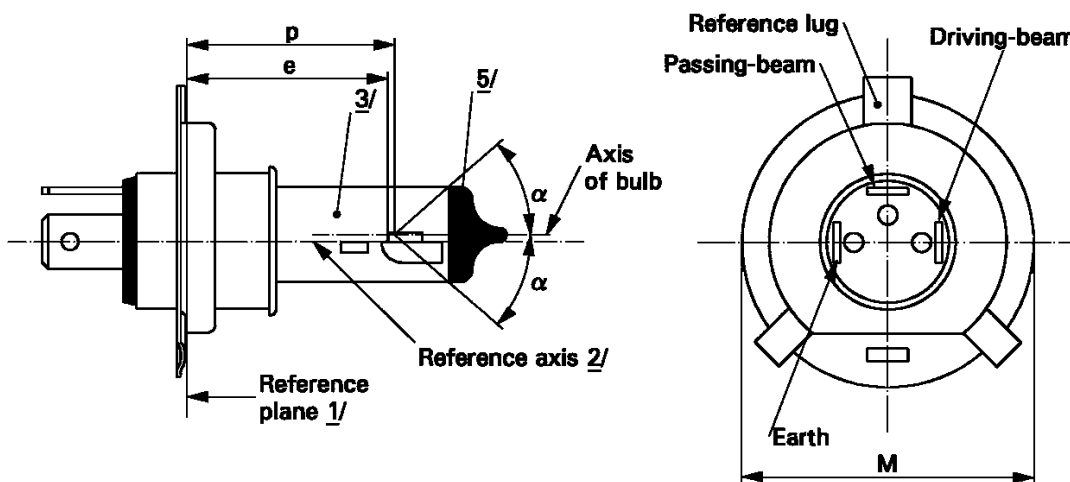

Figure 1 Main drawing

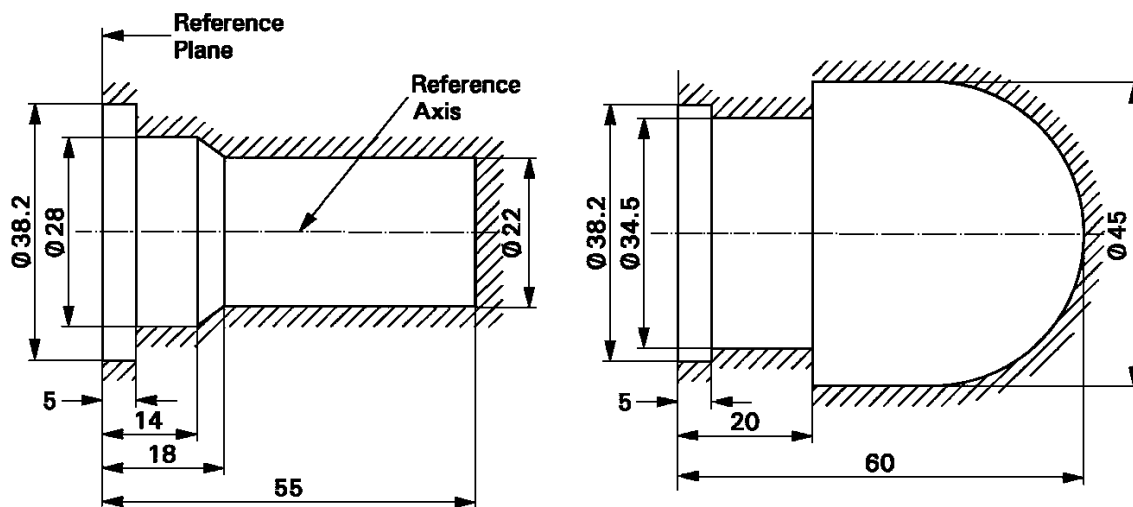

Figure 2

Maximum lamp outlines 4/

Figure 3

- 1/ The reference plane is the plane formed by the seating points of the three lugs of the cap ring.
- 2/ The reference axis is perpendicular to the reference plane and passes through the centre of the circle of diameter "M".
- 3/ The bulb shall be colourless or selective-yellow.
- 4/ The bulb and supports shall not exceed the envelope as in Figure 2. However, where a selective-yellow outer bulb is used the bulb and supports shall not exceed the envelope as in Figure 3.
- 5/ The obscuration shall extend at least as far as the cylindrical part of the bulb. It shall also overlap the internal shield when the latter is viewed in a direction perpendicular to the reference axis.

CATEGORY H4

Sheet H4/2

Dimensions in mm		Filament lamps of normal production				Standard filament lamp	
		12 V		24 V		12 V	
e		28.5 +0.35/-0.25		29.0 ± 0.35		28.5 + 0.20/-0.00	
p		28.95		29.25		28.95	
α		max. 40°				max. 40°	
Cap P43t in accordance with IEC Publication 60061 (sheet 7004-39-6)							
ELECTRICAL AND PHOTOMETRIC CHARACTERISTICS							
Rated values	Volts	12 <u>6/</u>		24 <u>6/</u>		12 <u>6/</u>	
	Watts	60	55	75	70	60	55
Test voltage	Volts	13.2		28.0		13.2	
Objective values	Watts	75 max.	68 max.	85 max.	80 max.	75 max.	68 max.
	Luminous flux ± %	1,650	1,000	1,900	1,200		
		15					
Measuring flux <u>7/</u> lm		-	750	-	800		
Reference luminous flux at approximately 12 V						1,250	750

6/ The value indicated in the left hand column relate to the driving-beam filament. Those indicated in the right-hand column relate to the passing beam filament.

7/ Measuring luminous flux for measuring according to paragraph 3.9. of this Regulation.

Position of shield

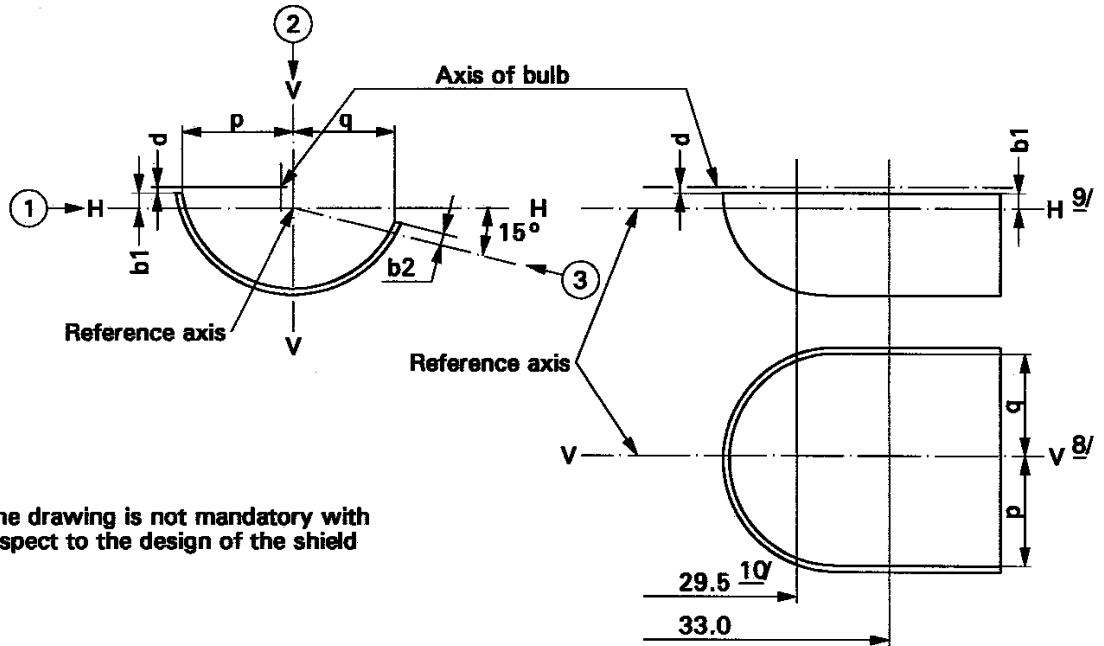

Position of filaments

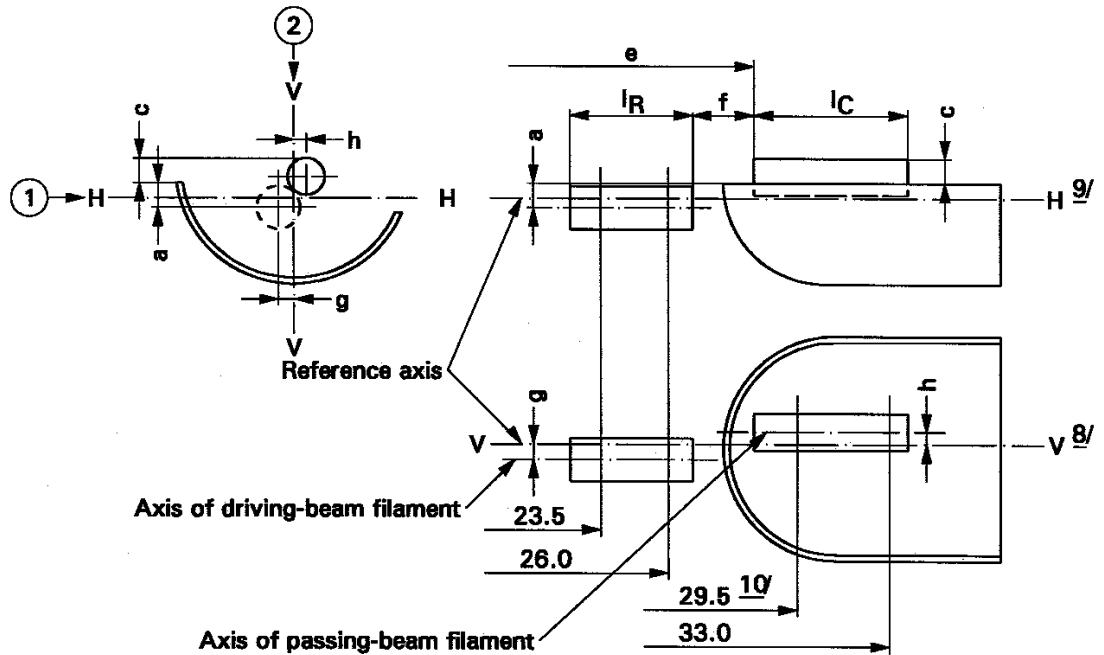

CATEGORY H4

Sheet H4/4

Table of the dimensions (in mm) referred to in the drawings on sheet H4/3

Reference <u>*/</u>		Dimension <u>**/</u>		Tolerance		
				Filaments lamps of normal production		Standard filament lamp
12 V	24 V	12 V	24 V	12 V	24 V	12 V
a/26		0.8		± 0.35		± 0.20
a/23.5		0.8		± 0.60		± 0.20
b1/29.5	30.0	0		± 0.30	± 0.35	± 0.20
b1/33		b1/29.5 mv	30.0 mv	± 0.30	± 0.35	± 0.15
b2/29.5	30.0	0		± 0.30	± 0.35	± 0.20
b2/33		b1/29.5 mv	30.0 mv	± 0.30	± 0.35	± 0.15
c/29.5	30.0	0.6	0.75	± 0.35		± 0.20
c/33		c/29.5 mv	30.0 mv	± 0.35		± 0.15
d		min. 0.1		-		-
e <u>13/</u>		28.5	29.0	+ 0.35 - 0.25	± 0.35	+ 0.20 - 0.00
f <u>11/ 12/ 13/</u>		1.7	2.0	+ 0.50 - 0.30	± 0.40	+ 0.30 - 0.10
g/26		0		± 0.50		± 0.30
g/23.5		0		± 0.70		± 0.30
h/29.5	30.0	0		± 0.50		± 0.30
h/33		h/29.5 mv	30.0 mv	± 0.35		± 0.20
lR <u>11/ 14/</u>		4.5	5.25	± 0.80		± 0.40
lC <u>11/ 12/</u>		5.5	5.25	± 0.50	± 0.80	± 0.35
p/33		Depends on the shape of the shield		-		-
q/33		(p+q)/2		± 0.60		± 0.30

*/ "./26" means dimension to be measured at the distance from the reference plane indicated in mm after the stroke.

**/ "29.5 mv" or "30.0 mv" means the value measured at a distance of 29.5 or 30.0 mm from the reference plane.

- 8/ Plane V-V is the plane perpendicular to the reference plane and passing through the reference axis and through the intersection of the circle of diameter "M" with the axis of the reference lug.
- 9/ Plane H-H is the plane perpendicular to both the reference plane and plane V-V and passing through the reference axis.
- 10/ 30.0 mm for the 24-Volt type.
- 11/ The end turns of the filament are defined as being the first luminous turn and the last luminous turn that are at substantially the correct helix angle. For coiled-coil filaments, the turns are defined by the envelope of the primary coil.
- 12/ For the passing-beam filament, the points to be measured are the intersections, seen in direction 1, of the lateral edge of the shield with the outside of the end turns defined under footnote 11/.
- 13/ "e" denotes the distance from the reference plane to the beginning of the passing beam filament as defined above.
- 14/ For the driving-beam filament the points to be measured are the intersections, seen in direction 1, of a plane, parallel to plane H-H and situated at a distance of 0.8 mm below it, with the end turns defined under footnote 11/.

Additional explanations to sheet H4/3

The dimensions below are measured in three directions:

- 1 for dimensions a, b1, c, d, e, f, lR and lC;
- 2 for dimensions g, h, p and q;
- 3 for dimension b2.

Dimensions p and q are measured in planes parallel to and 33 mm away from the reference plane.

Dimensions b1, b2, c and h are measured in planes parallel to and 29.5 mm (30.0 mm for 24 V filament lamps) and 33 mm away from the reference plane.

Dimensions a and g are measured in planes parallel to and 26.0 mm and 23.5 mm away from the reference plane.

Note: For the method of measurement, see Appendix E of IEC Publication 60809.

CATEGORY H7

Sheet H7/1

The drawings are intended only to illustrate the essential dimensions (in mm) of the filament lamp

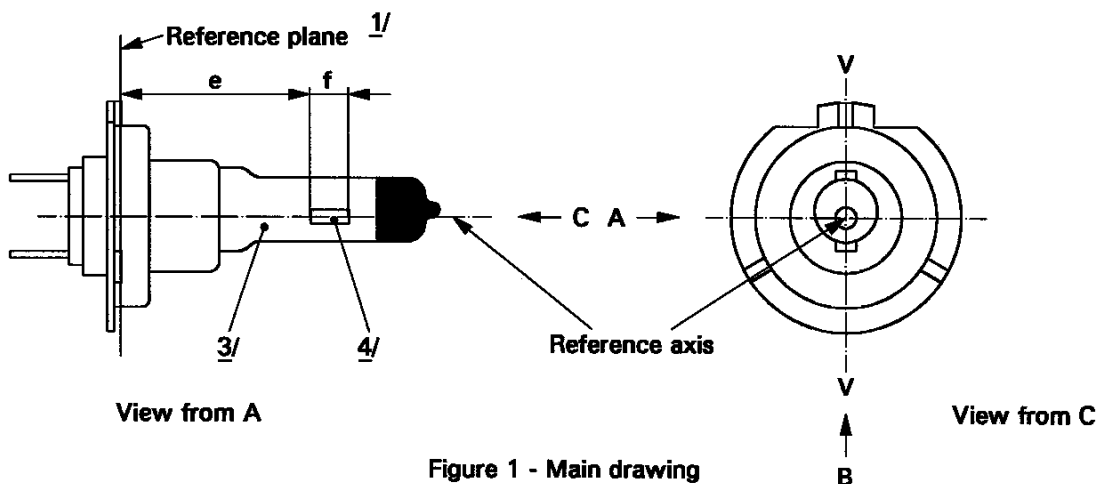

Figure 1 - Main drawing

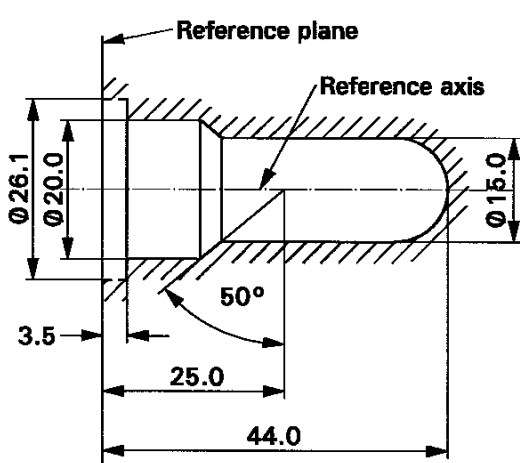

Figure 2 - Maximum lamp outline 5/

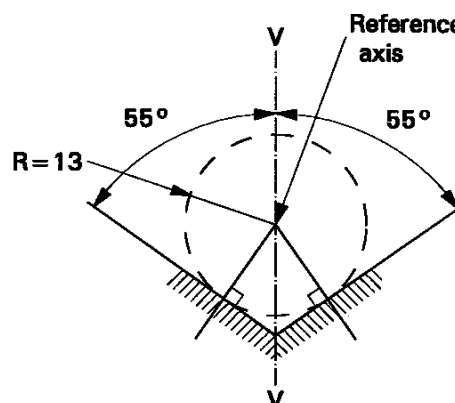
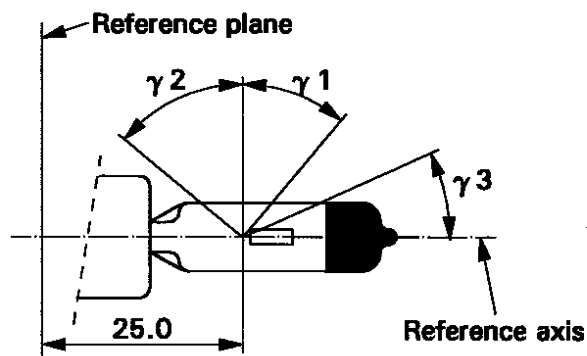

Figure 3 - Definition of reference axis 2/

- 1/ The reference plane is defined by the points on the surfaces of the holder on which the three supporting bosses of the cap ring will rest.
- 2/ The reference axis is perpendicular to the reference plane and crosses the intersection of the two perpendiculars as indicated in Figure 3.
- 3/ The bulb shall be colourless or selective-yellow.
- 4/ Notes concerning the filament diameter.
 - No actual diameter restrictions apply but the objective for future developments is to have $d_{max.} = 1.3$ mm for 12 V and $d_{max.} = 1.7$ for 24V filament lamps.
 - For the same manufacturer, the design diameter of standard (étalon) filament lamp and filament lamp of normal production shall be the same.
- 5/ Glass bulb and supports shall not exceed the envelope as indicated in Figure 2. The envelope is concentric to the reference axis.



View from B

Figure 4
 Distortion free area and black top 6/ 7/

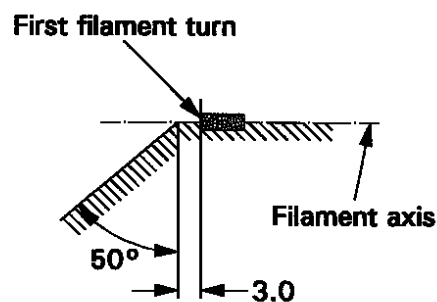

View from A

Figure 5
 Metal free zone 8/

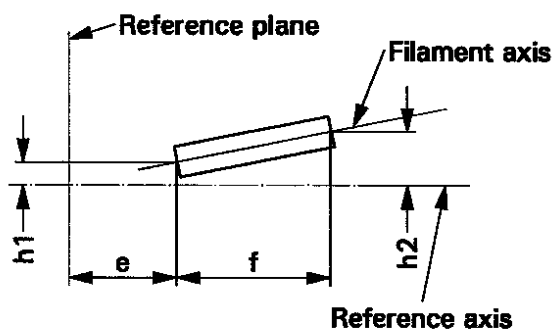

Figure 6
 Permissible offset of filament axis
 (for standard filament lamps only)

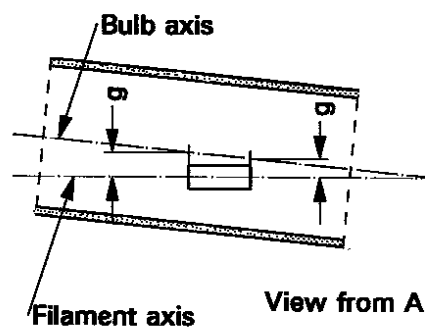

Figure 7
 Bulb eccentricity

- 6/ Glass bulb shall be optically distortion free within the angles γ_1 and γ_2 . This requirement applies to the whole bulb circumference within the angles γ_1 and γ_2 .
- 7/ The obscuration shall extend at least to angle γ_3 and shall extend at least to the cylindrical part of the bulb on the whole bulb top circumference.
- 8/ The internal design of the lamp shall be such that stray light images and reflections are only located above the filament itself seen from the horizontal direction. (View A as indicated in Figure 1 on sheet H7/1).
 No metal parts other than filament turns shall be located in the shaded area as seen in Figure 5.

CATEGORY H7

Sheet H7/3

Dimensions in mm	Filaments lamps of normal production		Standard filament lamp	
	12 V	24 V	12 V	
e <u>9/</u>	25.0	<u>10/</u>	25.0 ± 0.1	
f <u>9/</u>	4.1 <u>10/</u>	4.9 <u>10/</u>	4.1 ± 0.1	
g <u>12/</u>	0.5 min.		u.c.	
h1 <u>11/</u>	0	<u>10/</u>	0 ± 0.10	
h2 <u>11/</u>	0	<u>10/</u>	0 ± 0.15	
γ1	40° min.		40° min.	
γ2	50° min.		50° min.	
γ3	30° min.		30° min.	
Cap PX26d in accordance with IEC Publication 60061 (sheet 7004-5-6)				
ELECTRICAL AND PHOTOMETRIC CHARACTERISTICS				
Rated values	Volts	12	24	12
	Watts	55	70	55
Test voltage	Volts	13.2	28.0	13.2
Objective values	Watts	58 max.	75 max.	58 max.
	Luminous flux	1,500 ± 10 %	1,750 ± 10 %	
Reference luminous flux: 1,100 at approximately 12 V				

- 9/ The ends of the filament are defined as the points where, when the viewing direction is direction A as shown in Figure 1 on sheet H7/1, the projection of the outside of the end turns crosses the filament axis. (Special instructions for coiled-coil filaments are under consideration).
- 10/ To be checked by means of a "Box System", sheet H7/4.
- 11/ The offset of the filament with respect to the reference axis is measured only in viewing directions A and B as shown in Figure 1 in sheet H7/1. The points to be measured are those where the projection of the outside of the end turns nearest to or furthest from the reference plane crosses the filament axis.
- 12/ Offset of filament in relation to bulb axis measured in two planes parallel to the reference plane where the projection of the outside of the end turns nearest to or furthest from the reference plane crosses the filament axis.

Screen projection requirements

This test is used to determine, by checking whether the filament is correctly positioned relative to the reference axis and reference plane, whether a filament lamp complies with the requirements.

Dimensions in mm

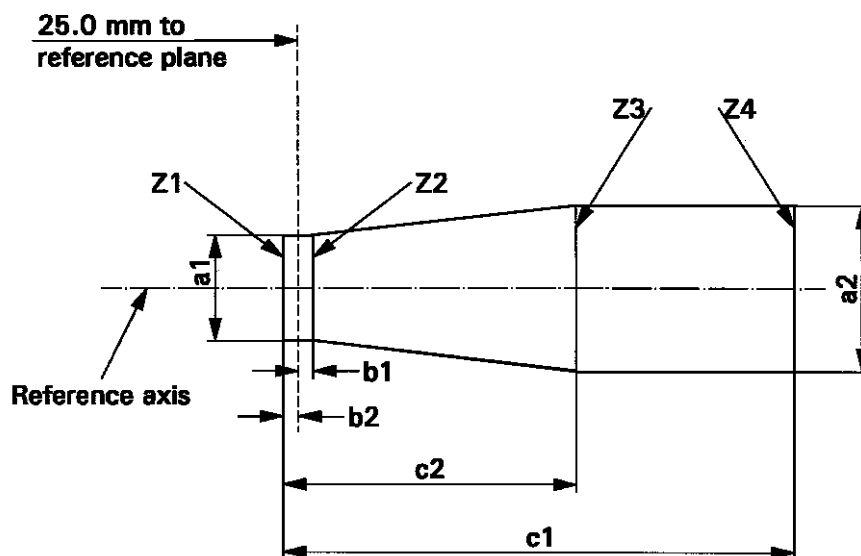

	a1	a2	b1	b2	c1	c2
12 V	$d + 0.30$	$d + 0.50$	0.2		4.6	4.0
24V	$d + 0.60$	$d + 1.00$	0.25		5.9	4.4

d = diameter of filament

The filament position is checked solely in directions A and B as shown on sheet H7/1, Figure 1.

The filament shall lie entirely within the limits shown.

The ends of the filament as defined on sheet H7/3, note 9/, shall lie between lines Z1 and Z2 and between Z3 and Z4.

CATEGORIES H8 AND H8B

Sheet H8/1

The drawings are intended only to illustrate the essential dimensions (in mm) of the filament lamp

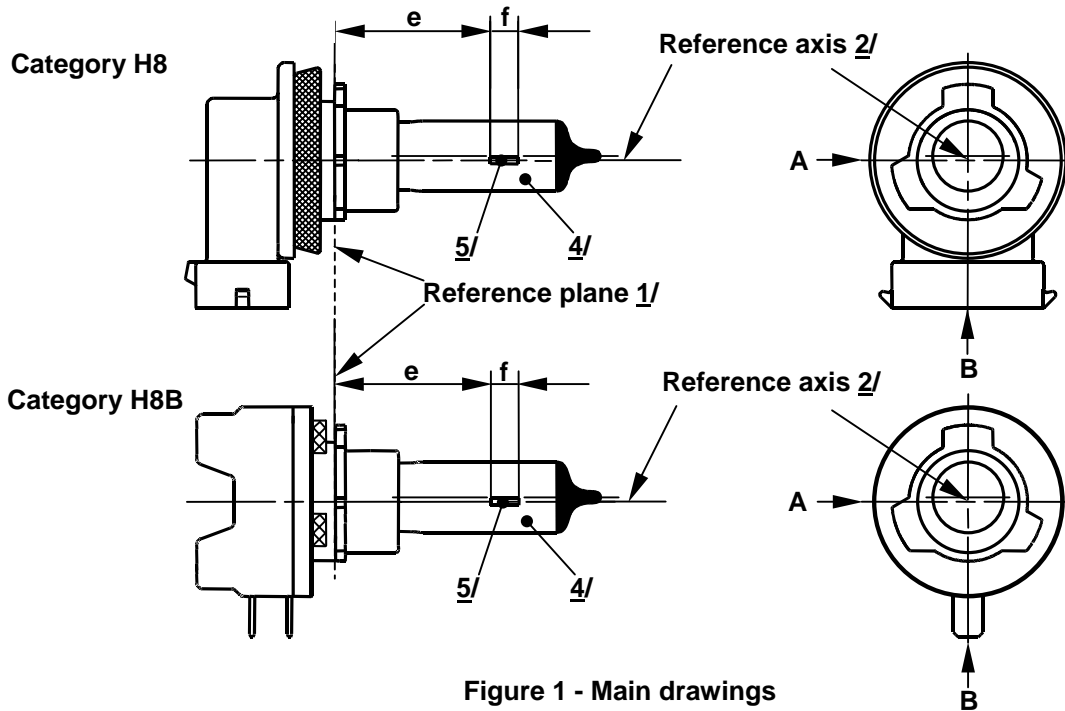

Figure 1 - Main drawings

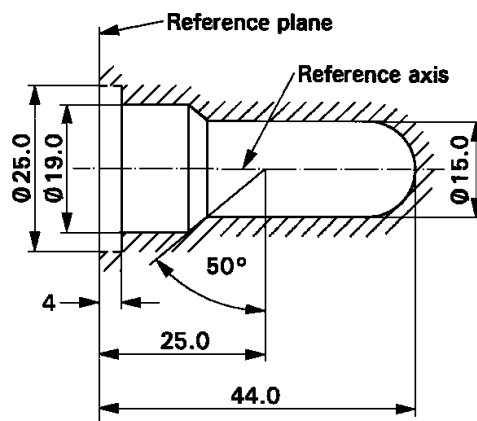
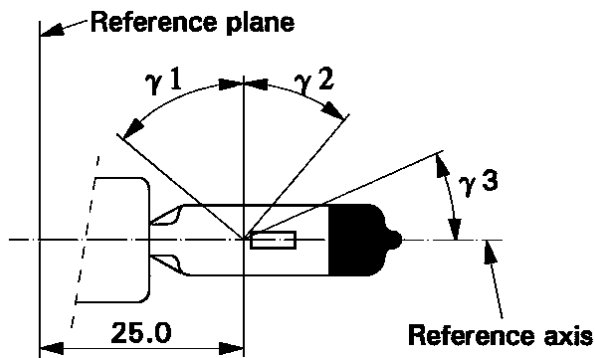

Figure 2 - Maximum lamp outline 3/

- 1/ The reference plane is the plane formed by the underside of the bevelled lead-in flange of the cap.
- 2/ The reference axis is perpendicular to the reference plane and passing through the centre of the 19 mm cap diameter.
- 3/ Glass bulb and supports shall not exceed the envelope as indicated in Figure 2. The envelope is concentric to the reference axis.
- 4/ The light emitted shall be white or selective yellow.
- 5/ Notes concerning the filament diameter.
 - No actual diameter restrictions apply but the objective for future developments is to have $d_{max} = 1.2$ mm.
 - For the same manufacturer, the design diameter of standard (étalon) filament lamp and filament lamp of normal production shall be the same.



View B

Figure 3
Distortion free area 6/ and black top 7/

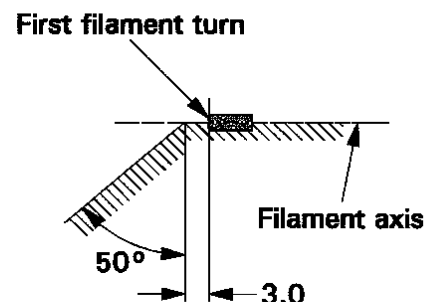

View A

Figure 4
Metal free zone 8/

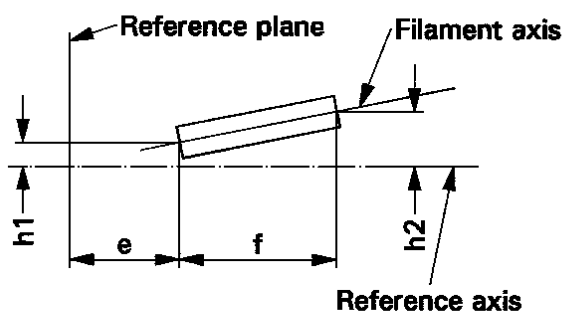

Figure 5
Permissible offset of filament axis 9/
(for standard filament lamps only)

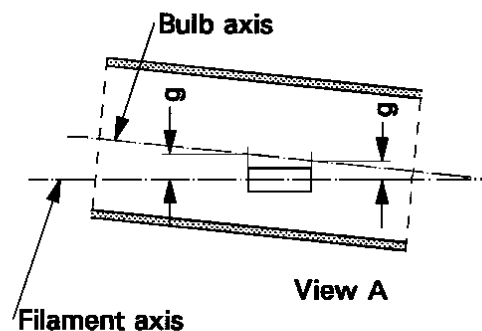

Figure 6
Bulb eccentricity 10/

- 6/ Glass bulb shall be optically distortion free within the angles γ_1 and γ_2 . This requirement applies to the whole bulb circumference within the angles γ_1 and γ_2 .
- 7/ The obscuration shall extend at least to angle γ_3 and shall extend at least to the cylindrical part of the bulb on the whole bulb top circumference.
- 8/ The internal design of the lamp shall be such that stray light images and reflections are only located above the filament itself seen from the horizontal direction. (View A as indicated in Figure 1 on sheet H8/1). No metal parts other than filament turns shall be located in the shaded area as seen in Figure 4.
- 9/ The offset of the filament with respect to the reference axis is measured only in viewing directions A and B as shown in Figure 1 in sheet H8/1. The points to be measured are those where the projection of the outside of the end turns nearest to or furthest from the reference plane crosses the filament axis.
- 10/ Offset of filament in relation to bulb axis measured in two planes parallel to the reference plane where the projection of the outside of the end turns nearest to or furthest from the reference plane crosses the filament axis.

CATEGORIES H8 AND H8B

Sheet H8/3

Dimensions in mm	Filaments lamps of normal production		Standard filament lamp
	12 V		12 V
e	<u>11/</u>	25.0 <u>12/</u>	25.0 ± 0.1
f	<u>11/</u>	3.7 <u>12/</u>	3.7 ± 0.1
g		0.5 min.	u.c.
h1		0 <u>12/</u>	0 ± 0.1
h2		0 <u>12/</u>	0 ± 0.15
γ1		50° min.	50° min.
γ2		40° min.	40° min.
γ3		30° min.	30° min.
Cap:	H8: PGJ19-1 H8B: PGJY19-1	in accordance with IEC Publication 60061 (sheet 7004-110-2) in accordance with IEC Publication 60061 (sheet 7004-...)	
ELECTRICAL AND PHOTOMETRIC CHARACTERISTICS			
Rated values	Volts	12	12
	Watts	35	35
Test voltage	Volts	13.2	13.2
Objective values	Watts	43 max.	43 max.
	Luminous flux	800 ± 15 %	
Reference luminous flux: 600 lm at approximately 12 V			

11/ The ends of the filament are defined as the points where, when the viewing direction is direction A as shown in Figure 1 on sheet H8/1, the projection of the outside of the end turns crosses the filament axis.

12/ To be checked by means of a "Box System"; sheet H8/4.

Screen projection requirements

This test is used to determine, by checking whether the filament is correctly positioned relative to the reference axis and reference plane, whether a filament complies with the requirements.

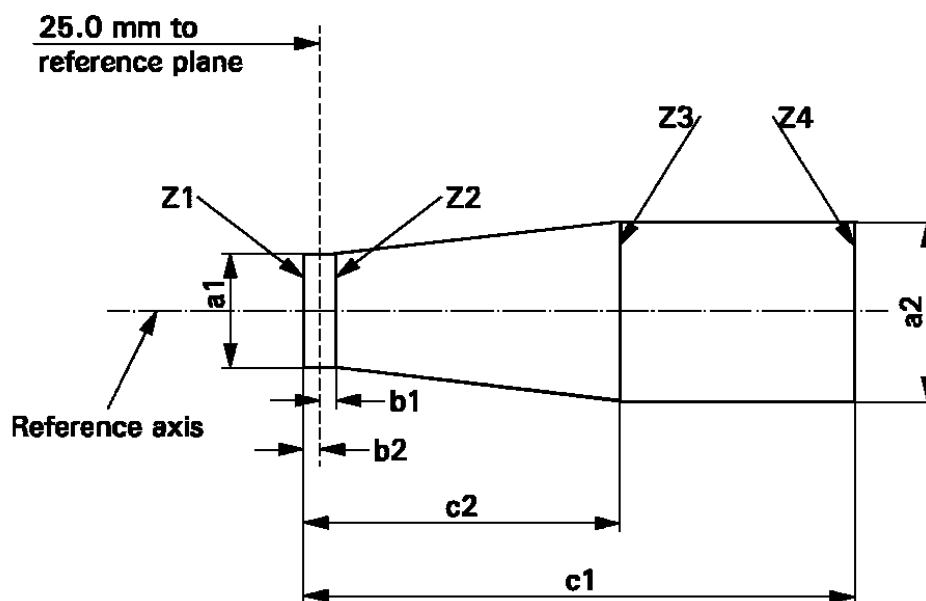

a1	a2	b1	b2	c1	c2
$d + 0.50$	$d + 0.70$	0.25		4.6	3.5

d = diameter of filament

The filament position is checked solely in directions A and B as shown on sheet H8/1, Figure 1.

The filament shall lie entirely within the limits shown.

The ends of the filament as defined on sheet H8/3, note 11/, shall lie between lines Z1 and Z2 and between Z3 and Z4.

CATEGORIES H9 AND H9B

Sheet H9/1

The drawings are intended only to illustrate the essential dimensions (in mm) of the filament lamp

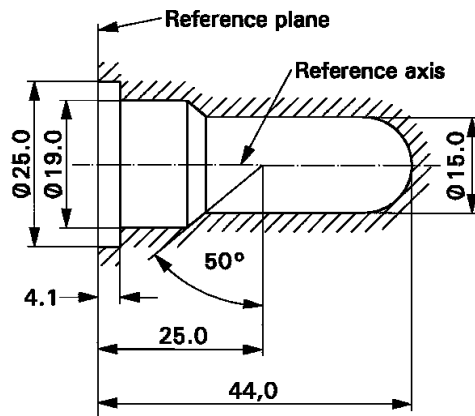
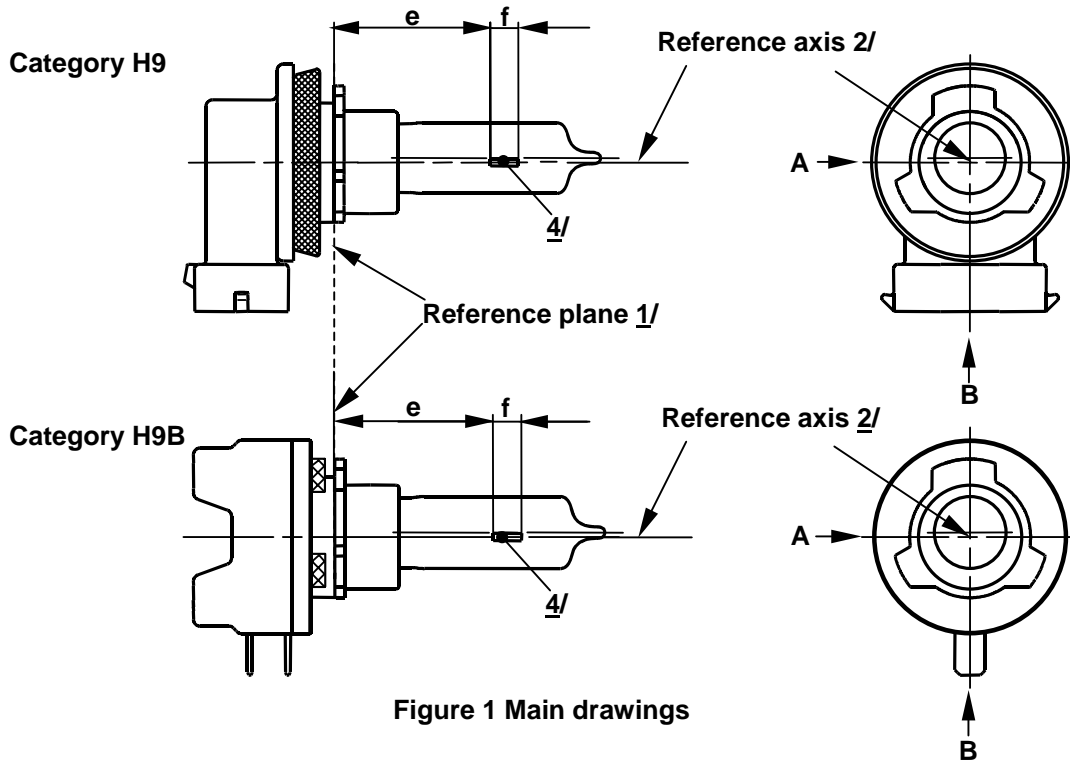

- 1/ The reference plane is the plane formed by the underside of the bevelled lead-in flange of the cap.
- 2/ The reference axis is perpendicular to the reference plane and passing through the centre of the 19 mm cap diameter .
- 3/ Glass bulb and supports shall not exceed the envelope as indicated in Figure 2. The envelope is concentric to the reference axis.
- 4/ Notes concerning the filament diameter.
 - No actual diameter restrictions apply but the objective for future developments is to have $d_{max.} = 1.4$ mm.
 - For the same manufacturer, the design diameter of standard (étalon) filament lamp and filament lamp of normal production shall be the same.

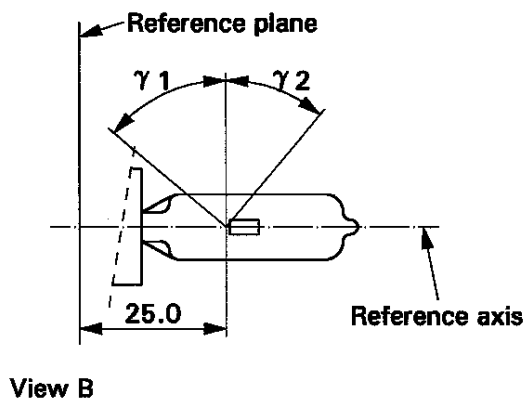

Figure 3
Distortion free area 5/

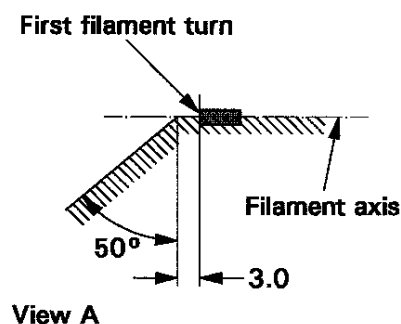

Figure 4
Metal free zone 6/

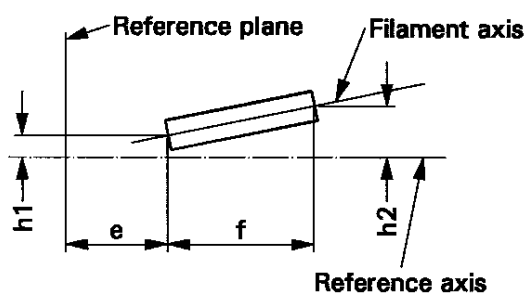

Figure 5
Permissible offset of filament axis 7/
(for standard filament lamps only)

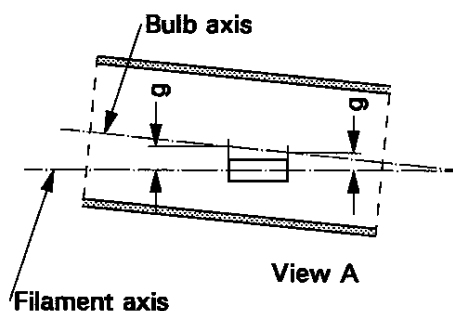

Figure 6
Bulb eccentricity 8/

- 5/ Glass bulb shall be optically distortion free within the angles γ_1 and γ_2 . This requirement applies to the whole bulb circumference within the angles γ_1 and γ_2 .
- 6/ The internal design of the lamp shall be such that stray light images and reflections are only located above the filament itself seen from the horizontal direction. (View A as indicated in Figure 1, sheet H9/1). No metal parts other than filament turns shall be located in the shaded area as seen in Figure 4.
- 7/ The offset of the filament with respect to the reference axis is measured only in viewing directions A and B as shown in Figure 1 on sheet H9/1. The points to be measured are those where the projection of the outside of the end turns nearest to or furthest from the reference plane crosses the filament axis.
- 8/ Offset of filament in relation to bulb axis measured in two planes parallel to the reference plane where the projection of the outside of the end turns nearest to or furthest from the reference plane crosses the filament axis.

CATEGORIES H9 AND H9B

Sheet H9/3

Dimensions in mm		Tolerances		
		Filaments lamps of normal production	Standard filament lamp	
		12 V	12 V	
e	<u>9/</u> <u>10/</u>	25	<u>11/</u>	± 0.10
f	<u>9/</u> <u>10/</u>	4.8	<u>11/</u>	± 0.10
g	<u>9/</u>	0.7	± 0.5	± 0.30
h1		0	<u>11/</u>	± 0.10 <u>12/</u>
h2		0	<u>11/</u>	± 0.15 <u>12/</u>
γ1		50° min.	-	-
γ2		40° min.	-	-
Cap:	H9: PGJ19-5 H9B: PGJY19-5	in accordance with IEC Publication 60061 (sheet 7004-110-2) in accordance with IEC Publication 60061 (sheet 7004-...)		
ELECTRICAL AND PHOTOMETRIC CHARACTERISTICS				
Rated values	Volts		12	12
	Watts		65	65
Test voltage	Volts		13.2	13.2
Objective values	Watts		73 max.	73 max.
	Luminous flux		2,100 ± 10%	
Reference luminous flux: 1,500 lm at approximately 12 V				

- 9/ The viewing direction is direction A as shown in Figure 1 on sheet H9/1.
- 10/ The ends of the filament are defined as the points where, when the viewing direction is as defined in note 9/ above, the projection of the outside of the end turns crosses the filament axis.
- 11/ To be checked by means of a "Box System"; sheet H9/4.
- 12/ The eccentricity is measured only in viewing directions A and B as shown in Figure 1 on sheet H9/1. The points to be measured are those where the projection of the outside of the end turns nearest or furthest from the reference plane crosses the filament axis.

Screen projection requirements

This test is used to determine, by checking whether the filament is correctly positioned relative to the reference axis and reference plane, whether a filament complies with the requirements.

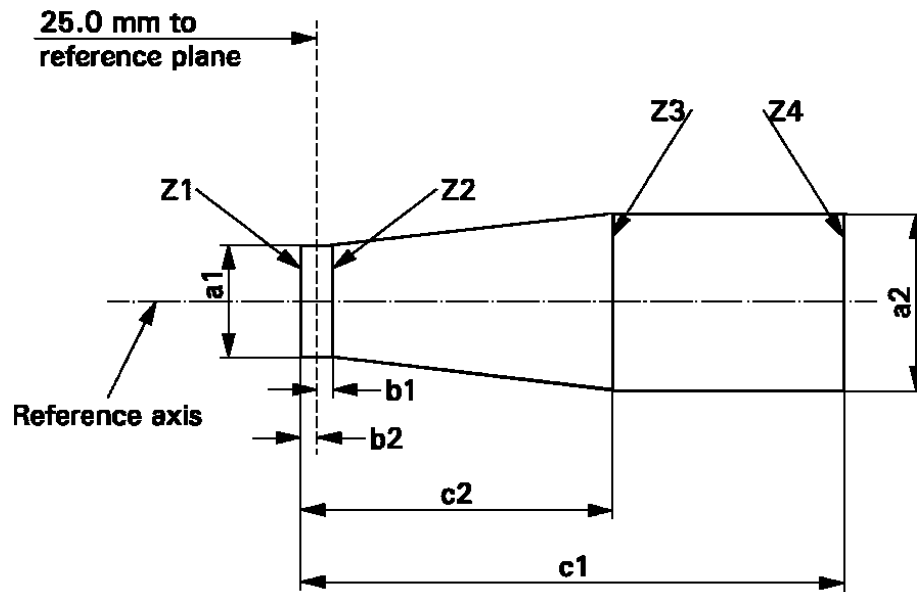

a1	a2	b1	b2	c1	c2
d + 0.4	d + 0.7	0.25		5.7	4.6

d = diameter of filament

The filament position is checked solely in directions A and B as shown on sheet H9/1, Figure 1.

The filament shall lie entirely within the limits shown.

The ends of the filament as defined on sheet H9/3, note 10/, shall lie between lines Z1 and Z2 and between Z3 and Z4.

CATEGORY H10

Sheet H10/1

The drawings are intended only to illustrate the essential dimensions (in mm) of the filament lamp

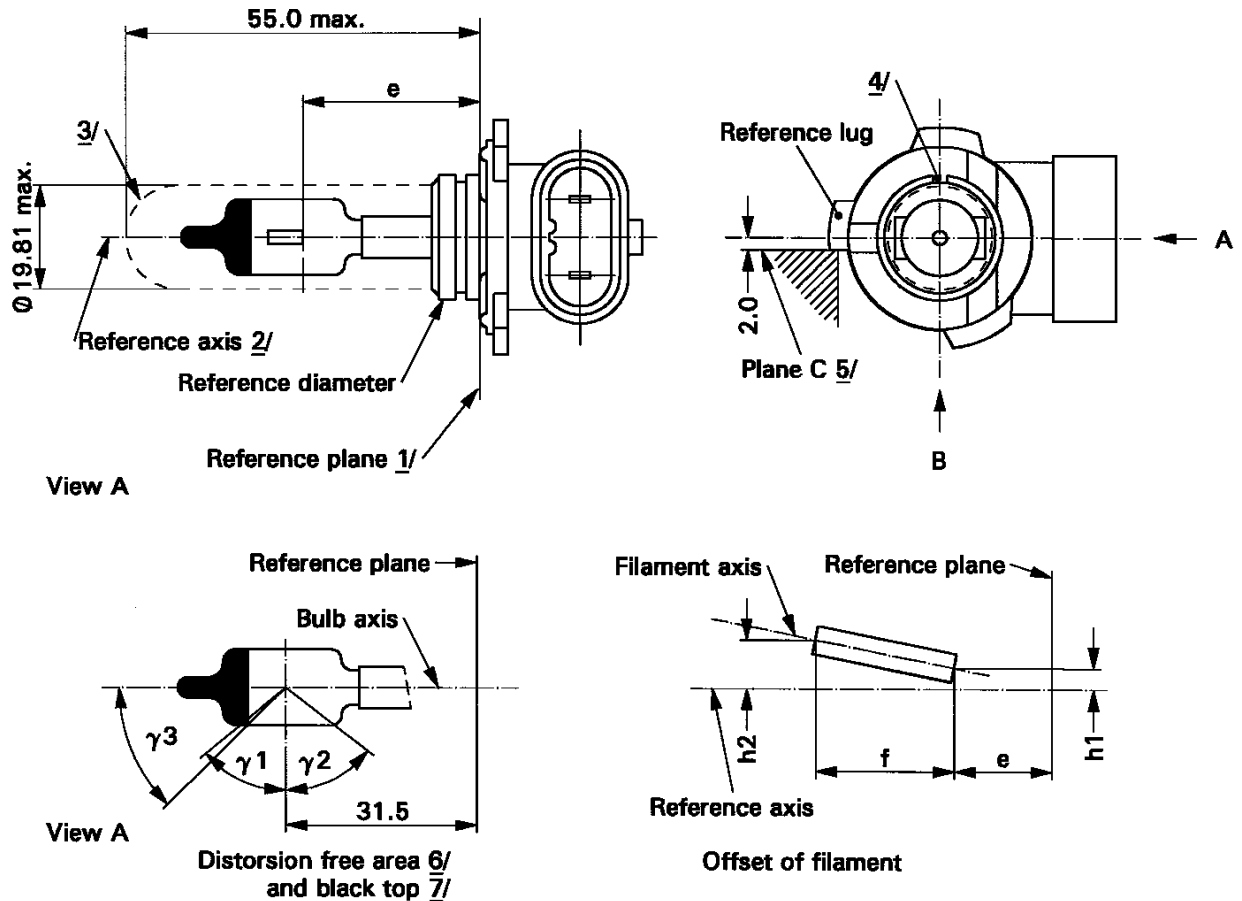

- 1/ The reference plane is the plane defined by the meeting points of cap-holder fit.
- 2/ The reference axis is perpendicular to the reference plane and concentric with the reference diameter of the cap.
- 3/ Glass bulb and supports shall not exceed the envelope and shall not interfere with insertion past the lamp key. The envelope is concentric to the reference axis.
- 4/ The keyway is mandatory.
- 5/ The filament lamp shall be rotated in the measuring holder until the reference lug contacts plane C of the holder.
- 6/ Glass bulb periphery shall be optically distortion-free axially within the angles γ_1 and γ_2 . This requirement applies to the whole bulb circumference within the angles γ_1 and γ_2 .
- 7/ The obscuration shall extend to at least angle γ_3 and shall be at least as far as the undistorted part of the bulb defined by angle γ_1 .

Dimensions in mm <u>8/</u>		Tolerance		
		Filament lamps of normal production	Standard filament lamp	
e	<u>9/ 10/</u>	28.9	<u>11/</u>	± 0.16
f	<u>9/ 10/</u>	5.2	<u>11/</u>	± 0.16
h1, h2		0	<u>11/</u>	± 0.15 <u>12/</u>
γ1		50° min.	-	-
γ2		52° min.	-	-
γ3		45°	± 5°	± 5°
Cap PY20d in accordance with IEC Publication 60061 (sheet 7004-31-2)				
ELECTRICAL AND PHOTOMETRIC CHARACTERISTICS				
Rated values	Volts		12	12
	Watts		42	42
Test voltage	Volts		13.2	13.2
Objective values	Watts		50 max.	50 max.
	Luminous flux		850 ± 15 %	
Reference luminous flux: 600 lm at approximately 12 V				

8/ Dimensions shall be checked with O-ring removed.

9/ The viewing direction is direction */ B as shown in the figure on sheet H10/1.

10/ The ends of the filament are defined as the points where, when the viewing direction */ as defined in note 9/ above, the projection of the outside of the end turns crosses the filament axis.

11/ To be checked by means of a "Box-System", sheet H10/3. */

12/ The eccentricity is measured only in viewing directions */ A and B as shown in the figure on sheet H10/1. The points to be measured are those where the projection of the outside of the end turns nearest to or furthest from the reference plane crosses the filament axis.

*/ Manufacturers may choose another set of perpendicular viewing directions. The viewing directions specified by the manufacturer are to be used by the testing laboratory when checking filament dimensions and position.

CATEGORY H10

Sheet H10/3

Screen projection requirements

This test is used to determine, by checking whether the filament is correctly positioned relative to the reference axis and reference plane, whether a filament lamp complies with the requirements.

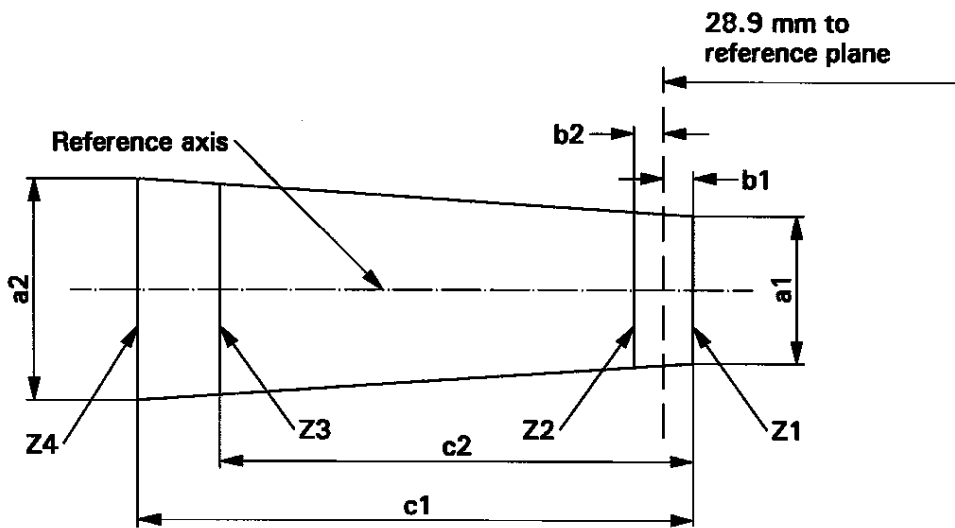

	a1	a2	b1	b2	c1	c2
12 V	1.4 d	1.8 d	0.25		6.1	4.9

d = diameter of filament

The filament position is checked solely in directions A and B as shown on sheet H10/1.

The filament shall lie entirely within the limits shown.

The ends of the filament as defined on sheet H10/2 note 10/ shall lie between lines Z1 and Z2 and between lines Z3 and Z4.

CATEGORIES H11 AND H11B

Sheet H11/1

The drawings are intended only to illustrate the essential dimensions (in mm) of the filament lamp

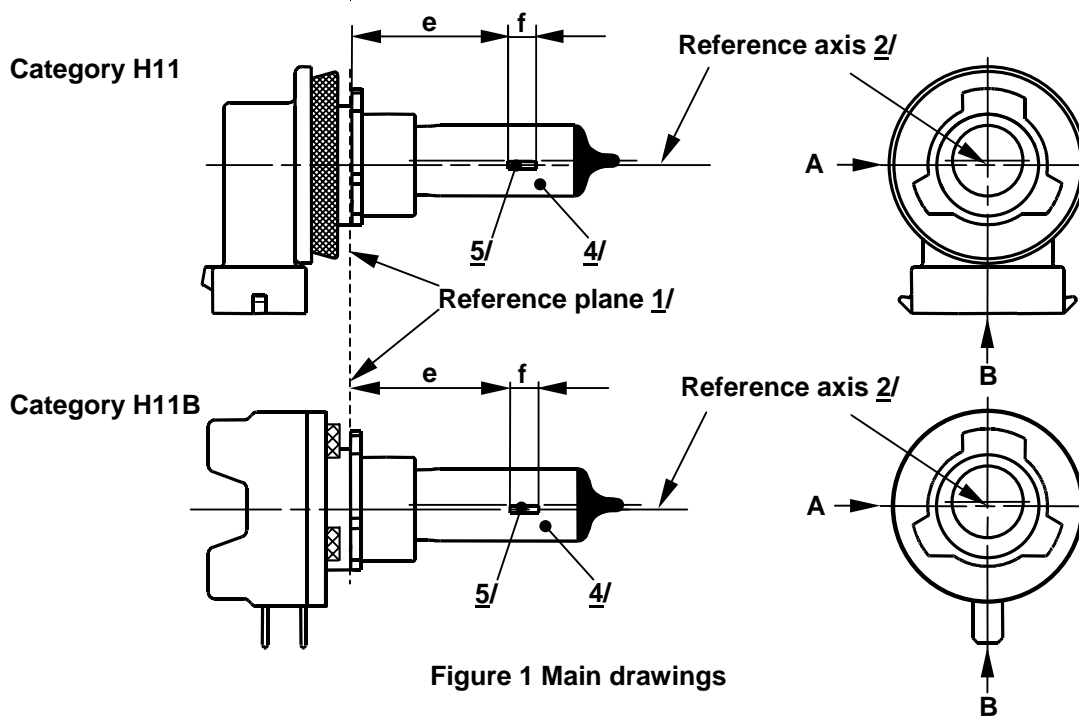

Figure 1 Main drawings

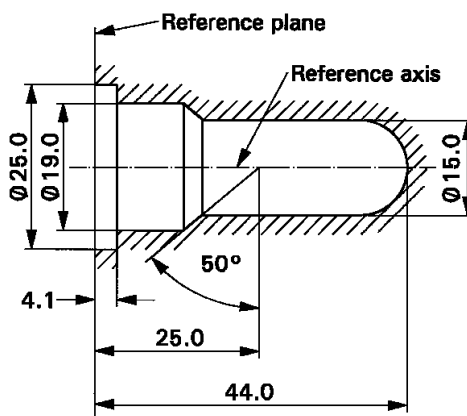
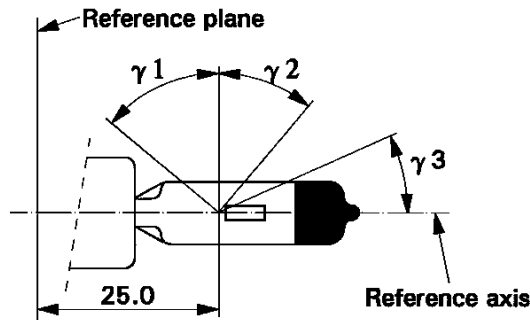

Figure 2 - Maximum lamp outline 3/

- 1/ The reference plane is the plane formed by the underside of the bevelled lead-in flange of the cap.
- 2/ The reference axis is perpendicular to the reference plane and passing through the centre of the 19 mm cap diameter.
- 3/ Glass bulb and supports shall not exceed the envelope as indicated in Figure 2. The envelope is concentric to the reference axis.
- 4/ The light emitted shall be white or selective yellow.
- 5/ Notes concerning the filament diameter.
 - No actual diameter restrictions apply but the objective for future developments is to have $d_{max} = 1.4$ mm.
 - For the same manufacturer, the design diameter of standard (étalon) filament lamp and filament lamp of normal production shall be the same.



View B

Figure 3
Distortion free area 6/ and black top 7/

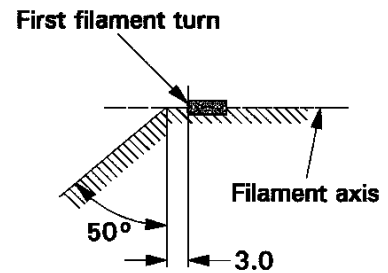

View A

Figure 4
Metal free zone 8/

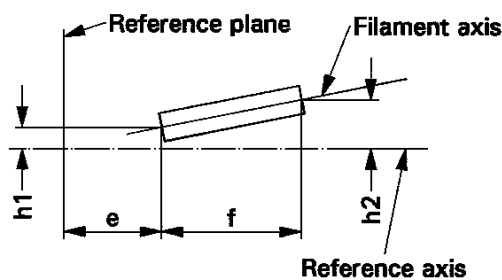

Figure 5
Permissible offset of filament axis 9/
(for standard filament lamps only)

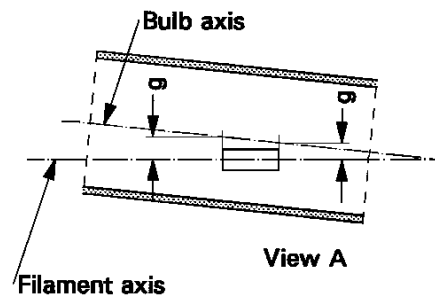

Figure 6
Bulb eccentricity 10/

- 6/ Glass bulb shall be optically distortion free within the angles γ_1 and γ_2 . This requirement applies to the whole bulb circumference within the angles γ_1 and γ_2 .
- 7/ The obscuration shall extend at least to angle γ_3 and shall extend at least to the cylindrical part of the bulb on the whole bulb top circumference.
- 8/ The internal design of the lamp shall be such that stray light images and reflections are only located above the filament itself seen from the horizontal direction (view A as indicated in Figure 1 on sheet H11/1). No metal parts other than filament turns shall be located in the shaded area as seen in Figure 4.
- 9/ The offset of the filament with respect to the reference axis is measured only in viewing directions A and B as shown in Figure 1 on sheet H11/1. The points to be measured are those where the projection of the outside of the end turns nearest to or furthest from the reference plane crosses the filament axis.
- 10/ Eccentricity of bulb axis with respect to filament axis measured in two planes parallel to the reference plane where the projection of the outside of the end turns nearest to or furthest from the reference plane crosses the filament axis.

CATEGORIES H11 AND H11B

Sheet H11/3

Dimensions in mm	Filaments lamps of normal production		Standard filament lamp	
	12 V	24 V	12 V	
e <u>11/</u>	25.0	<u>12/</u>	25.0 ± 0.1	
f <u>11/</u>	4.5	5.3 <u>12/</u>	4.5 ± 0.1	
g	0.5 min.		u.c.	
h1	0	<u>12/</u>	0 ± 0.1	
h2	0	<u>12/</u>	0 ± 0.15	
γ1	50° min.		50° min.	
γ2	40° min.		40° min.	
γ3	30° min.		30° min.	
Cap:	H11: PGJ19-2 H11B: PGJY19-2	in accordance with IEC Publication 60061 (sheet 7004-110-2) in accordance with IEC Publication 60061 (sheet 7004-...)		
ELECTRICAL AND PHOTOMETRIC CHARACTERISTICS				
Rated values	Volts	12	24	12
	Watts	55	70	55
Test voltage	Volts	13.2	28.0	13.2
Objective values	Watts	62 max.	80 max.	62 max.
	Luminous flux	1350 ± 10 %	1600 ± 10 %	
Reference luminous flux: 1,000 lm at approximately 12 V				

11/ The ends of the filament are defined as the points where, when the viewing direction is View A as shown in Figure 1 on sheet H11/1, the projection of the outside of the end turns crosses the filament axis.

12/ To be checked by means of a "Box System"; sheet H11/4.

CATEGORIES H11 AND H11B

Sheet H11/4

Screen projection requirements

This test is used to determine, by checking whether the filament is correctly positioned relative to the reference axis and reference plane, whether a filament complies with the requirements.

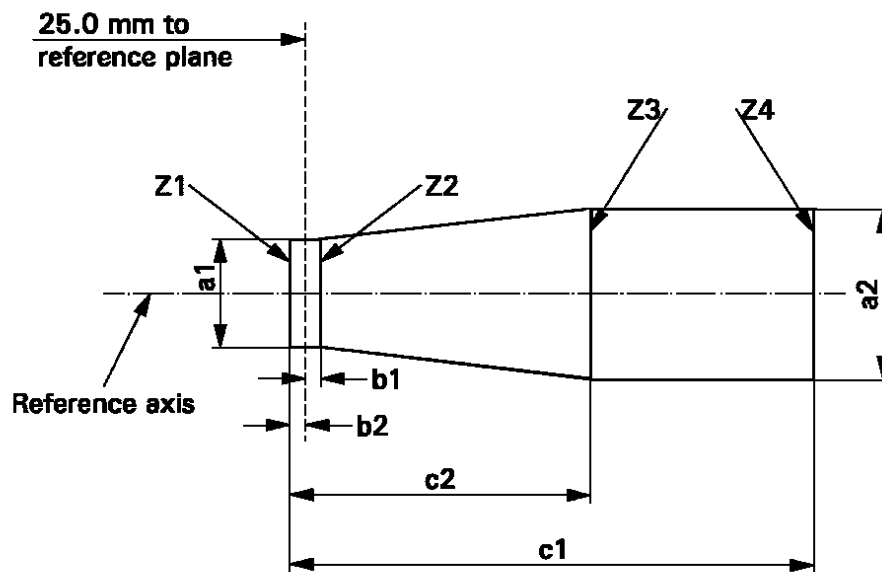

	a1	a2	b1	b2	c1	c2
12 V	$d + 0.3$	$d + 0.5$	0.2		5.0	4.0
24 V	$d + 0.6$	$d + 1.0$	0.25		6.3	4.6

d = diameter of filament

The filament position is checked solely in directions A and B as shown on sheet H11/1, Figure 1.

The filament shall lie entirely within the limits shown.

The ends of the filament as defined on sheet H11/3, note 11/, shall lie between lines Z1 and Z2 and between Z3 and Z4.

CATEGORY H12

Sheet H12/1

The drawings are intended only to illustrate the essential dimensions (in mm) of the filament lamp

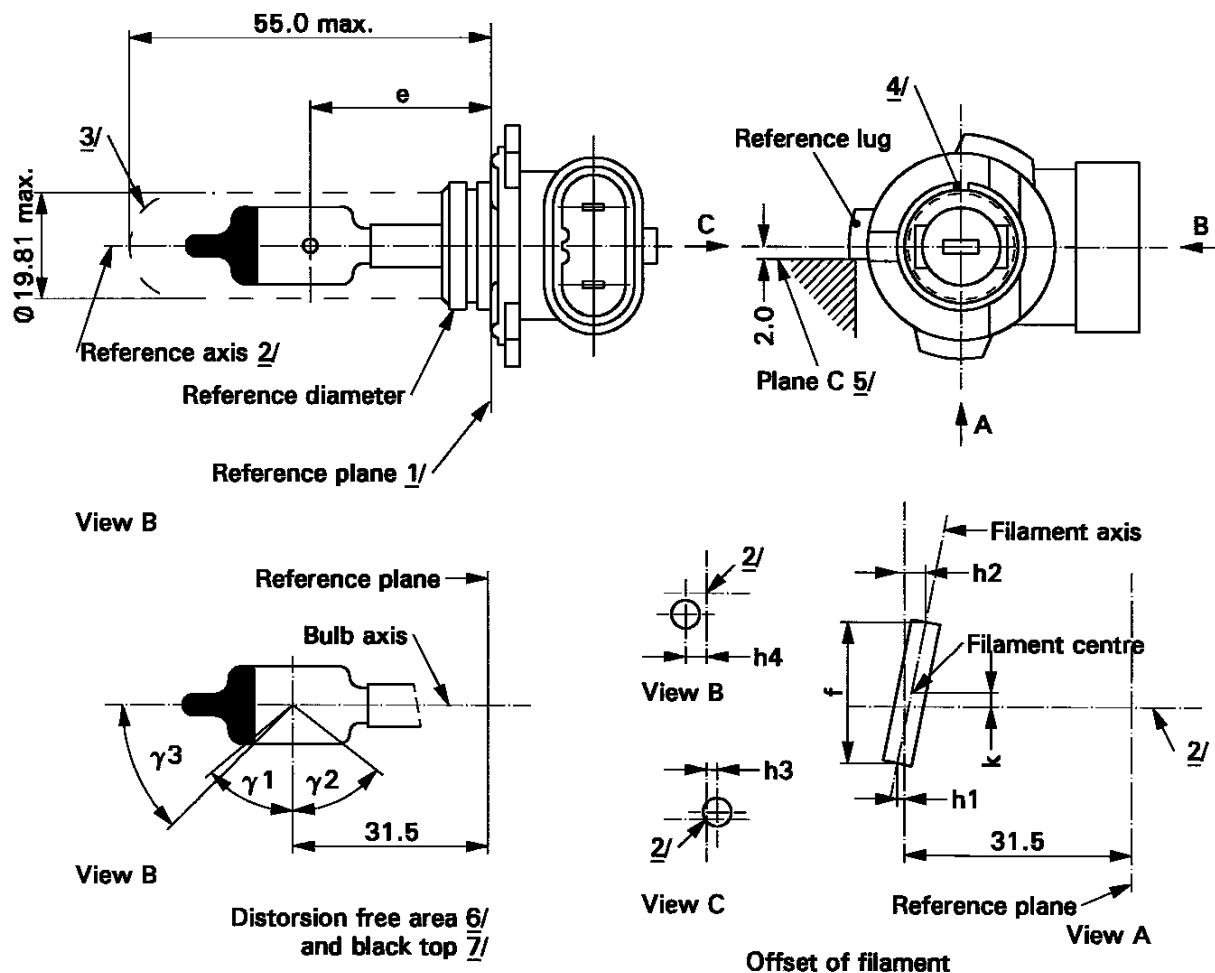

- 1/ The reference plane is the plane defined by the meeting points of cap-holder fit.
- 2/ The reference axis is perpendicular to the reference plane and concentric with the reference diameter of the cap.
- 3/ Glass bulb and supports shall not exceed the envelope and shall not interfere with insertion past the lamp key. The envelope is concentric to the reference axis.
- 4/ The keyway is mandatory.
- 5/ The filament shall be rotated in the measuring holder until the reference lug contacts plane C of the holder.
- 6/ Glass bulb periphery shall be optically distortion-free axially within the angles γ_1 and γ_2 . This requirement applies to the whole bulb circumference within the angles γ_1 and γ_2 .
- 7/ The obscuration shall extend to at least angle γ_3 and shall be at least as far as the undistorted part of the bulb defined by angle γ_1 .

CATEGORY H12

Sheet H12/2

Dimensions in mm <u>8/</u>		Tolerance		
		Filament lamps of normal production	Standard filament lamp	
e	<u>9/ 10/</u>	31.5	<u>11/</u>	± 0.16
f	<u>9/ 10/</u>	5.5	<u>11/</u>	± 0.16
h1, h2, h3, h4		0	<u>11/</u>	± 0.15 <u>12/</u>
k		0	<u>11/</u>	± 0.15 <u>13/</u>
γ1		50° min.	-	-
γ2		52° min.	-	-
γ3		45°	± 5°	± 5°
Cap PZ20d in accordance with IEC Publication 60061 (sheet 7004-31-2)				
ELECTRICAL AND PHOTOMETRIC CHARACTERISTICS				
Rated values	Volts		12	12
	Watts		53	53
Test voltage	Volts		13.2	13.2
Objective values	Watts		61 max.	61 max.
	Luminous flux		1,050 ± 15 %	
Reference luminous flux: 775 lm at approximately 12 V				

8/ Dimensions shall be checked with O-ring removed.

9/ The viewing direction is direction A as shown in the figure on sheet H12/1.

10/ The ends of the filament are defined as the points where, when the viewing direction as defined in note 9/ above, the projection of the outside of the end turns crosses the filament axis.

11/ To be checked by means of a "Box-System"; sheet H12/3.

12/ Dimensions h1 and h2 are measured in viewing direction A, dimension h3 in direction C and dimension h4 in direction B as shown in the figure on sheet H12/1. The points to be measured are those where the projection of the outside of the end turns nearest to or furthest from the reference plane crosses the filament axis.

13/ Dimension k is measured only in viewing direction A.

Screen projection requirements

This test is used to determine, by checking whether the filament is correctly positioned relative to the reference axis and reference plane, whether a filament lamp complies with the requirements.

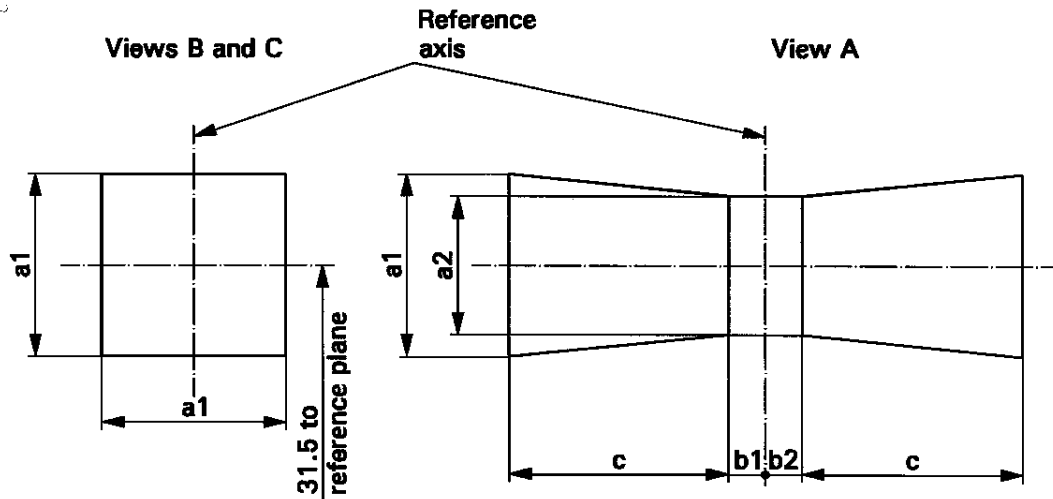

a1	a2	b1	b2	c
1.6 d	1.3 d	0.30	0.30	2.8

d = diameter of filament

For the directions of view A, B and C, see sheet H12/1.

The filament shall lie entirely within the limits shown.

The centre the filament shall lie between the limits of dimensions b1 and b2.

CATEGORIES H13 AND H13A

Sheet H13/1

The drawings are intended only to illustrate the essential dimensions (in mm) of the filament lamp

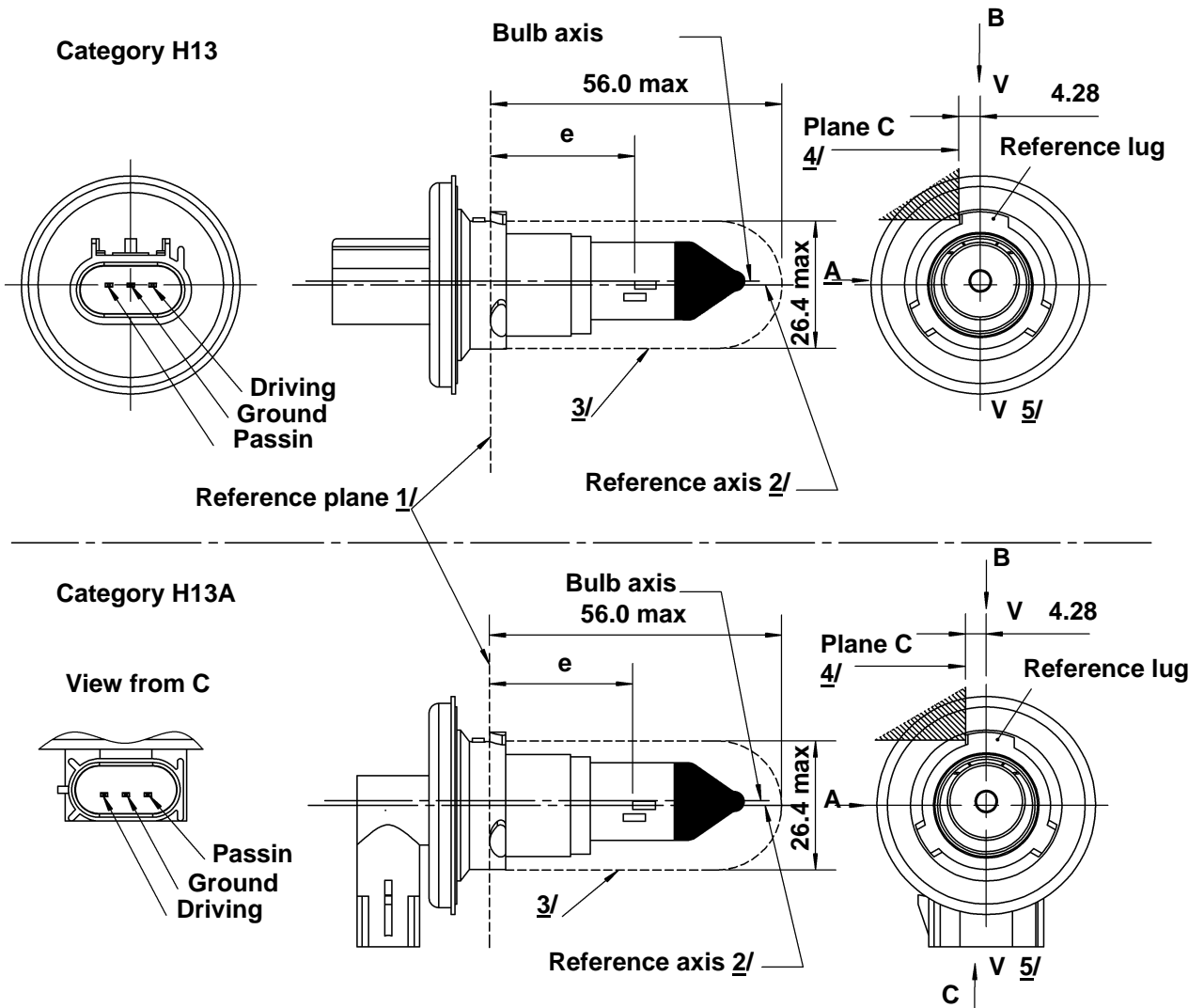

Figure 1 Main drawing

- 1/ The reference plane is the plane formed by the underside of the three radiused tabs of the cap.
- 2/ The reference axis is perpendicular to the reference plane and crosses the intersection of the two perpendiculars as indicated in Figure 2 on sheet H13/2.
- 3/ Glass bulb and supports shall not exceed the envelope as indicated. The envelope is concentric to the reference axis.
- 4/ The filament lamp shall be rotated in the measuring holder until the reference lug contacts plane C of the holder.
- 5/ Plane V-V is the plane perpendicular to the reference plane passing through the reference axis and parallel to plane C.

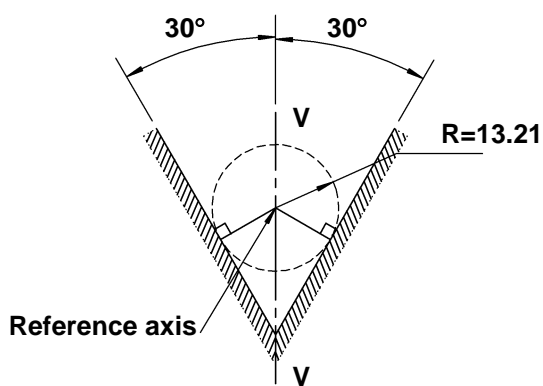

Figure 2
Definition of reference axis 2/

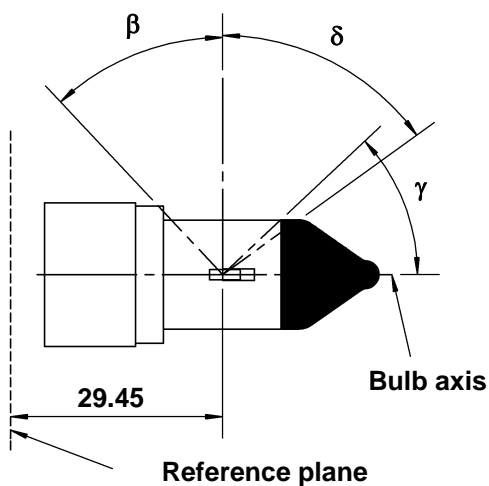
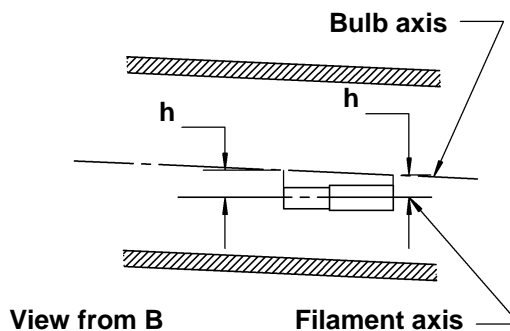
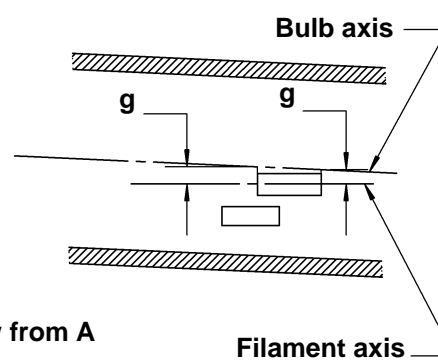

Figure 3
Undistorted area 6/
and opaque coating 7/



View from B



View from A

Figure 4
Bulb offset 8/

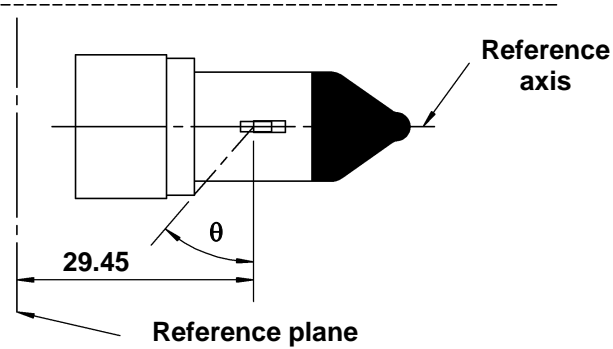

Figure 5
Light blocking toward cap 9/

- 6/ Glass bulb shall be optically distortion-free axially within the angles β and δ . This requirement applies to the whole bulb circumference within the angles β and δ .
- 7/ The opaque coating shall extend to angle γ and shall extend at least to the cylindrical part of the bulb on the whole bulb circumference.
- 8/ Offset of passing-beam filament in relation to the bulb axis is measured in two planes parallel to the reference plane where the projection of the outside end turns nearest to and farthest from the reference plane crosses the passing-beam filament axis.
- 9/ Light shall be blocked over the cap end of the bulb extending to angle θ . This requirement applies in all directions around the reference axis.

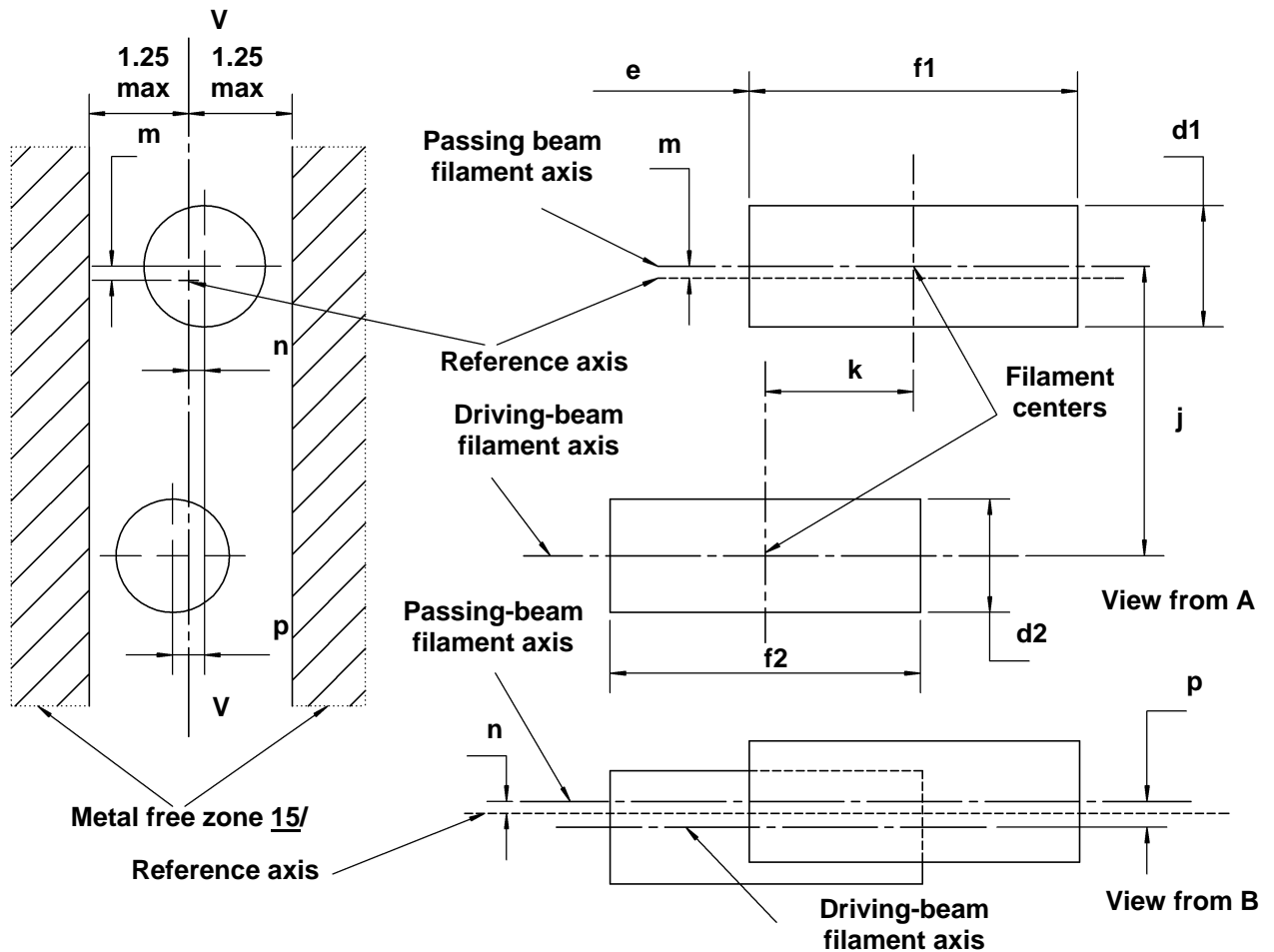

Figure 6
Position and dimensions of filaments 10/ 11/ 12/ 13/ 14/

- 10/ Dimensions j , k and p are measured from the centre of the passing-beam filament to the centre of the driving-beam filament.
- 11/ Dimensions m and n are measured from the reference axis to the centre of the passing-beam filament.
- 12/ Both filaments axis are to be held within a 2° tilt with respect to the reference axis about the centre of the respective filament.
- 13/ Note concerning the filament diameters.
 - For the same manufacturer, the design filament diameter of standard (étalon) filament lamp and filament lamp of normal production shall be the same.
- 14/ For both the driving-beam and the passing-beam filament distortion shall not exceed ± 5 per cent of filament diameter from a cylinder.
- 15/ The metal free zone limits the location of lead wires within the optical path. No metal parts shall be located in the shaded area as seen in Figure 6.

CATEGORIES H13 AND H13A

Sheet H13/4

Dimensions in mm			Tolerance			
			Filaments lamps of normal production		Standard filament lamp	
d1	<u>13/ 17/</u>	1.8 max.	-		-	
d2	<u>13/ 17/</u>	1.8 max.	-		-	
e	<u>16/</u>	29.45	± 0.20		± 0.10	
f1	<u>16/</u>	4.6	± 0.50		± 0.25	
f2	<u>16/</u>	4.6	± 0.50		± 0.25	
g	<u>8/ 17/</u>	0.5 d1	± 0.40		± 0.20	
h	<u>8/</u>	0	± 0.30		± 0.15	
j	<u>10/</u>	2.5	± 0.20		± 0.10	
k	<u>10/</u>	2.0	± 0.20		± 0.10	
m	<u>11/</u>	0	± 0.20		± 0.13	
n	<u>11/</u>	0	± 0.20		± 0.13	
p	<u>10/</u>	0	± 0.08		± 0.08	
β		42° min.	-		-	
δ		52° min.	-		-	
γ		43°	+0° / -5°		+0° / -5°	
θ	<u>9/</u>	41°	± 4°		± 4°	
Cap:	H13: P26.4t H13A: PJ26.4t	in accordance with IEC Publication 60061 (sheet 7004-128-2)				
ELECTRICAL AND PHOTOMETRIC CHARACTERISTICS <u>18/</u>						
Rated values	Volts	12		12		
	Watts	55	60	55	60	
Test voltage	Volts	13.2		13.2		
Objective values	Watts	68 max.	75 max.	68 max.	75 max.	
	Luminous flux	1,100 ± 15%	1,700 ± 15%			
Reference luminous flux: 800/1,200 lm at approximately 12 V						

- 16/ The ends of the filament are defined as the points where, when the viewing direction is direction A as shown on sheet H13/1, the projection of the outside of the end turns crosses the filament axis.
- 17/ d1 is the actual diameter of the passing-beam filament. d2 is the actual diameter of the driving-beam filament.
- 18/ The values indicated in the left-hand columns relate to the passing-beam filament and those indicated in the right-hand columns to the driving-beam filament.

CATEGORY H14

Sheet H14/1

The drawings are intended only to illustrate the essential dimensions (in mm) of the filament lamp

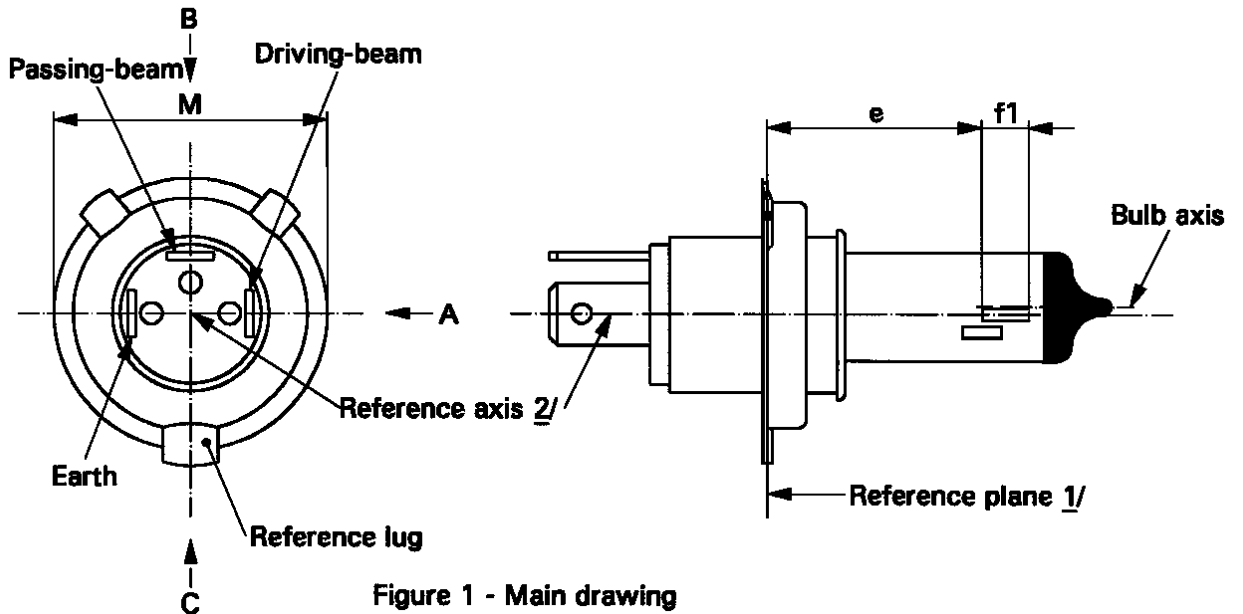

Figure 1 - Main drawing

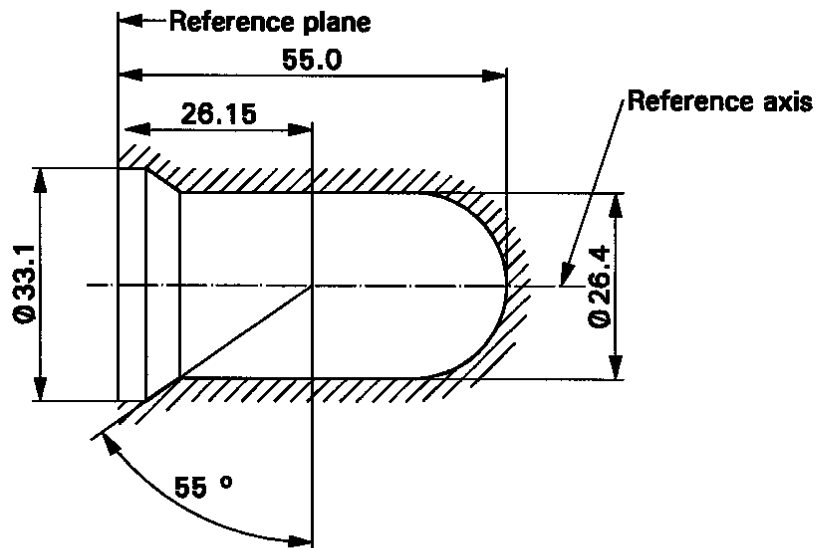
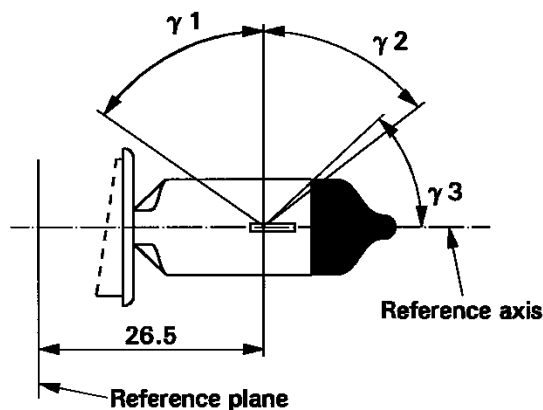
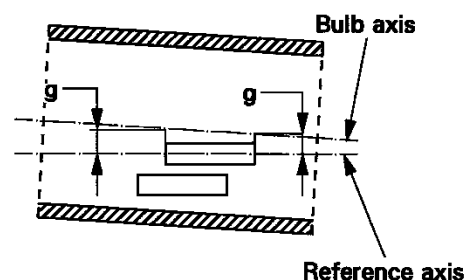

Figure 2 - Maximum lamp outline 3/

- 1/ The reference plane is defined by the points on the surface of the holder on which the three lugs of the cap ring will rest.
- 2/ The reference axis is perpendicular to the reference plane and passing through the centre of the cap ring diameter "M"
- 3/ Glass bulb and supports shall not exceed the envelope as indicated in Figure 2. The envelope is concentric to the reference axis.



View B Figure 3 - Distortion free area 4/ and black top 5/



View A Figure 4 - Bulb eccentricity 6/

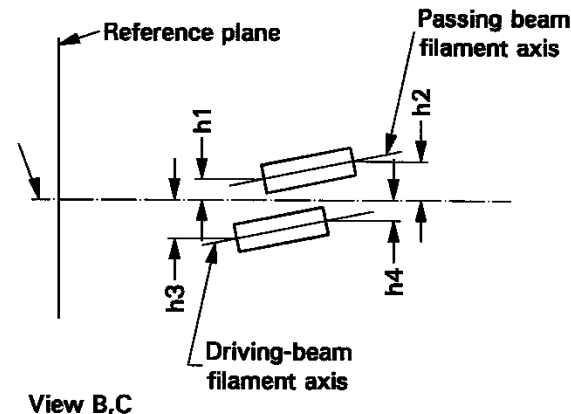
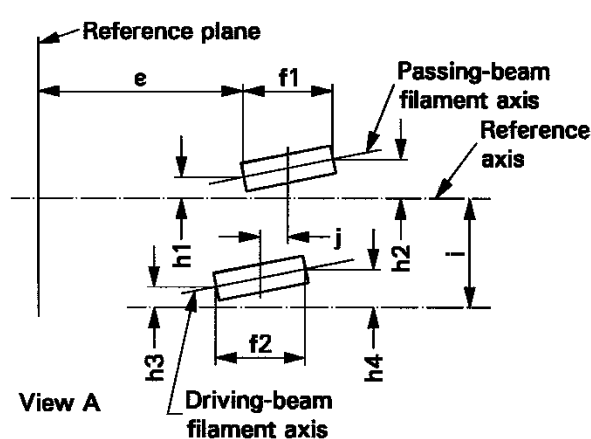

View A View B,C Figure 5- Offset of filament axis 7/ (for standard filament lamps only)

- 4/ Glass bulb shall be optically distortion free within the angles γ_1 and γ_2 . This requirement applies to the whole bulb circumference within the angles γ_1 and γ_2 .
- 5/ The obscuration shall extend at least to angle γ_3 and shall extend at least to the cylindrical part of the bulb on the whole bulb top circumference.
- 6/ Eccentricity of bulb with respect to passing-beam filament axis is measured in two planes parallel to the reference plane where the projection of the outside of the end turns nearest to or furthest from the reference plane crosses the passing-beam filament axis.
- 7/ The offset of the filaments with respect to the reference axis is measured only in viewing direction A, B and C as shown in Figure 1 on sheet H14/1. The points to be measured are those where the projection of the outside of the end turns nearest to or furthest from the reference plane crosses the filaments axis.

CATEGORY H14

Sheet H14/3

Dimensions in mm		Filament lamp of normal production	Standard filament lamps		
e	<u>8/</u>	26.15	<u>12/</u>	± 0.1	
f1	<u>8/ 9/</u>	5.3	<u>12/</u>	± 0.1	
f2	<u>8/ 9/</u>	5.0	<u>12/</u>	± 0.1	
g		0.3 min.			
h1		0	<u>12/</u>	± 0.1	
h2		0	<u>12/</u>	± 0.15	
h3		0	<u>12/</u>	± 0.15	
h4		0	<u>12/</u>	± 0.15	
i		2.7		-	
j		2.5	<u>12/</u>	± 0.1	
γ1		55° min.	-	-	
γ2		52° min.	-	-	
γ3		43°	0/-5°	0/5°	
Cap P38t-33 in accordance with IEC Publication 60061 (sheet 7004-133-1)					
ELECTRICAL AND PHOTOMETRIC CHARACTERISTICS					
Rated values	Volts	12		12	
	Watts	55	60	55	60
Test voltage	Volts	13.2		13.2	
Objective values	Watts	68 max.	75 max.	68 max.	75 max.
	Luminous flux	1,150 ± 15%	1,750 ± 15%		
Reference luminous flux at approximately 12 V				860	1,300

8/ The ends of the filaments are defined as the points where, when the viewing direction is direction A as shown in Figure 1 on sheet H14/1, the projection of the outside of the end turns crosses the filaments axis.

9/ "f1" represents the length of the passing-beam filament and "f2" represents the length of the driving-beam filament.

10/ "d1" represents the diameter of the passing-beam filament and "d2" represents the diameter of the driving-beam filament.

11/ Notes concerning the filaments diameter.

- No actual diameter restrictions apply but the objective for future developments is to have d1 max. = 1.6 mm and d2 max. = 1.6 mm.
- For the same manufacture, the design diameter of standard filament lamps and filament lamps of normal production shall be the same.

12/ To be checked by means of a "Box system"; sheet H14/4.

Screen projection requirements

This test is used to determine, by checking whether the filaments are correctly positioned relative to the reference axis and the reference plane, whether a filament lamp complies with the requirements.

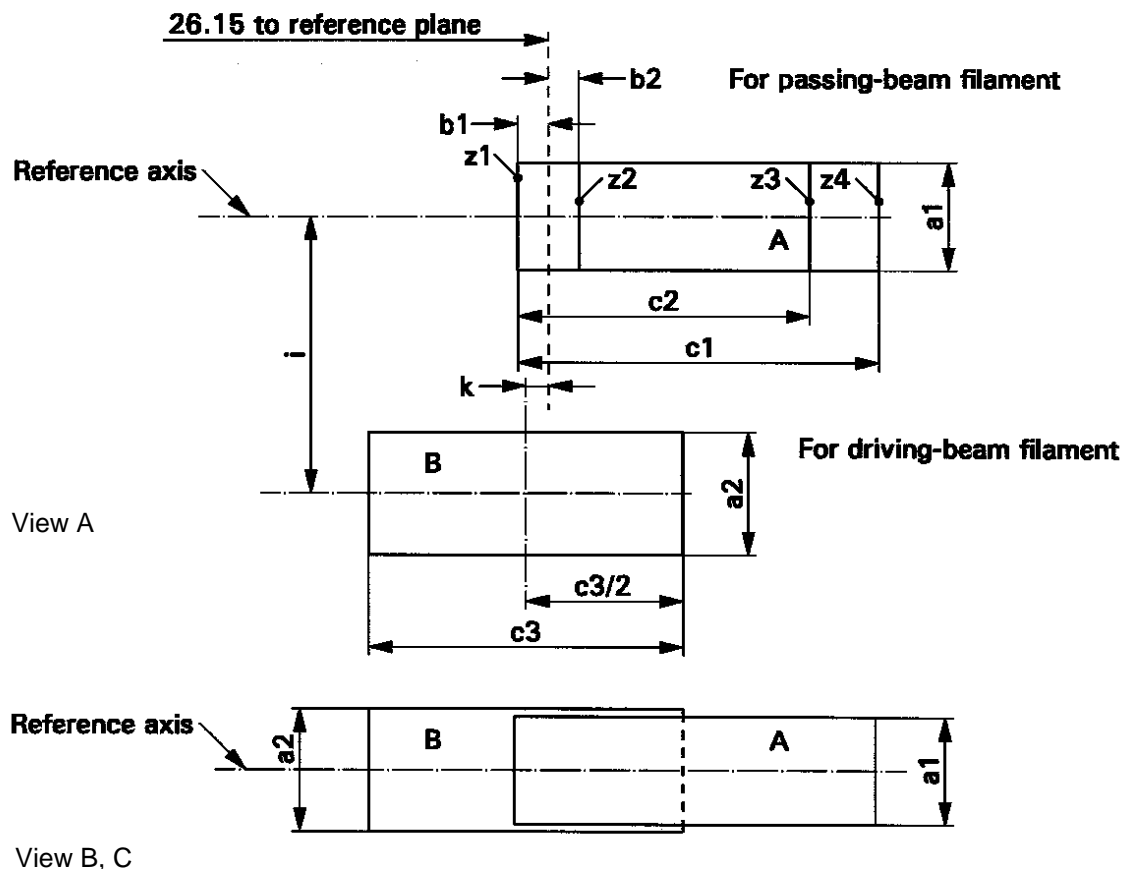

a1	a2	b1	b2	c1	c2	c3	i	k
d1 +0.5	1.6 * d2	0.2		5.8	5.1	5.75	2.7	0.15

d1 is diameter of the passing beam filament and d2 that of the driving beam filament

The positions of the filaments are checked solely in directions A, B and C as shown in Figure 1 on sheet H14/1.

The passing-beam filament shall lie entirely in the rectangle A and the driving beam filament entirely in rectangle B.

The ends of the passing-beam filament as defined on sheet H14/3, note 8/ shall lie between lines Z1 and Z2 and between lines Z3 and Z4.

CATEGORY H6W

Sheet H6W/1

The drawings are intended only to illustrate the essential dimensions (in mm) of the filament lamp

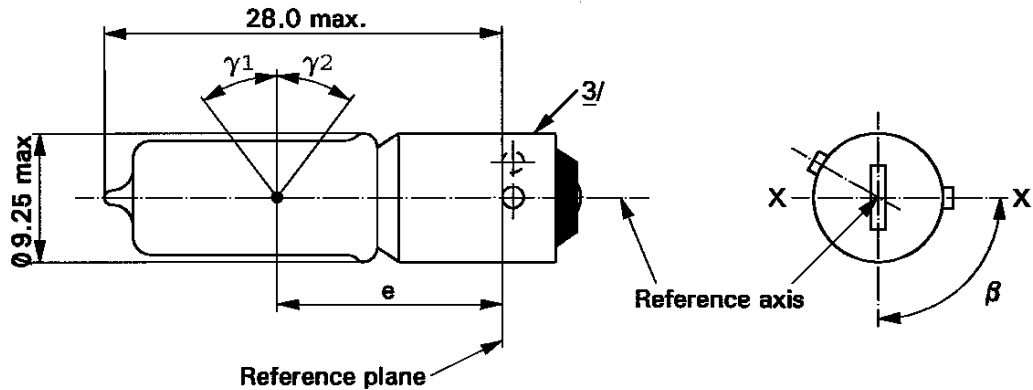

Dimensions in mm	Filament lamps of normal production			Standard filament lamp
	min.	nom.	max.	
e	14.25	15.0	15.75	15.0 ± 0.25
Lateral deviation <u>1/</u>			0.75	0.4 max
α	82.5°	90°	97.5°	$90^\circ \pm 5^\circ$
γ_1, γ_2 <u>2/</u>	30°			30° min.
Cap BAX9s in accordance with IEC Publication 60061 (sheet 7004-8-1)				
ELECTRICAL AND PHOTOMETRIC CHARACTERISTICS				
Rated values	Volts	12		12
	Watts	6		6
Test voltage	Volts	13.5		13.5
Objective values	Watts	7.35 max.		7.35 max.
	Luminous flux	$125 \pm 12\%$		
Reference luminous flux: 125 lm at approximately 13.5 V				

- 1/ Maximum lateral deviation of filament centre from two mutually perpendicular planes both containing the reference axis and one containing axis X-X.
- 2/ In the area between the outer legs of the angles γ_1 and γ_2 , the bulb shall have no optically distorting areas and the curvature of the bulb shall have a radius not less than 50 per cent of the actual bulb diameter.
- 3/ Over the entire length of the cap there shall be no projections or soldering exceeding the permissible maximum diameter of the cap.

CATEGORY H21W

Sheet H21W/1

The drawings are intended only to illustrate the essential dimensions (in mm) of the filament lamp

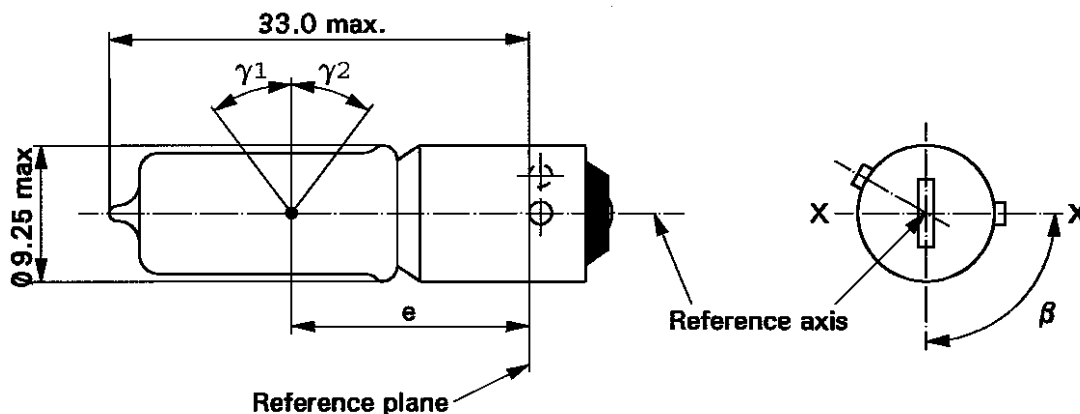

Dimensions in mm		Filament lamps of normal production			Standard filament lamp
		min.	nom.	max.	
e			20.0 <u>1/</u>		20.0 ± 0.25
f	12 V			3.8	3.8 + 0/ - 1
	24 V			4.5	
Lateral deviation <u>2/</u>				<u>1/</u>	0.0 ± 0.15 <u>3/</u>
β		82.5°	90°	97.5°	90° ± 5°
γ1, γ2 <u>4/</u>		45°			45° min.
Cap BAY9s in accordance with IEC Publication 60061 (sheet 7004-9-1)					
ELECTRICAL AND PHOTOMETRIC CHARACTERISTICS					
Rated values	Volts	12		24	12
	Watts	21		21	21
Test voltage	Volts	13.5		28.0	13.5
Objective values	Watts	26.25 max.		29.4 max.	26.25 max.
	Luminous flux	600 ± 12 %		600 ± 15 %	
Reference luminous flux: 600 lm at approximately 13.5 V					

- 1/ To be checked by means of a "Box System", sheet H21W/2.
- 2/ Maximum lateral deviation of filament centre from two mutually perpendicular planes both containing the reference axis and one containing axis X-X.
- 3/ The lateral deviation with respect to the plane perpendicular to axis X-X, is measured in the position described in clause 1 of the test procedure on sheet H21W/2.
- 4/ In the area between the outer legs of the angles γ1 and γ2, the bulb shall have no optical distorting areas and the curvature of the bulb shall have a radius not less than 50 per cent of the actual bulb diameter.

CATEGORY H21W

Sheet H21W/2

Screen projection requirements

This test is used to determine, by checking whether the filament is correctly positioned relative to the reference axis and reference plane and has an axis perpendicular, within $\pm 7.5^\circ$, to the plane through the centre line of the reference pin and the reference axis, whether a filament lamp complies with the requirements

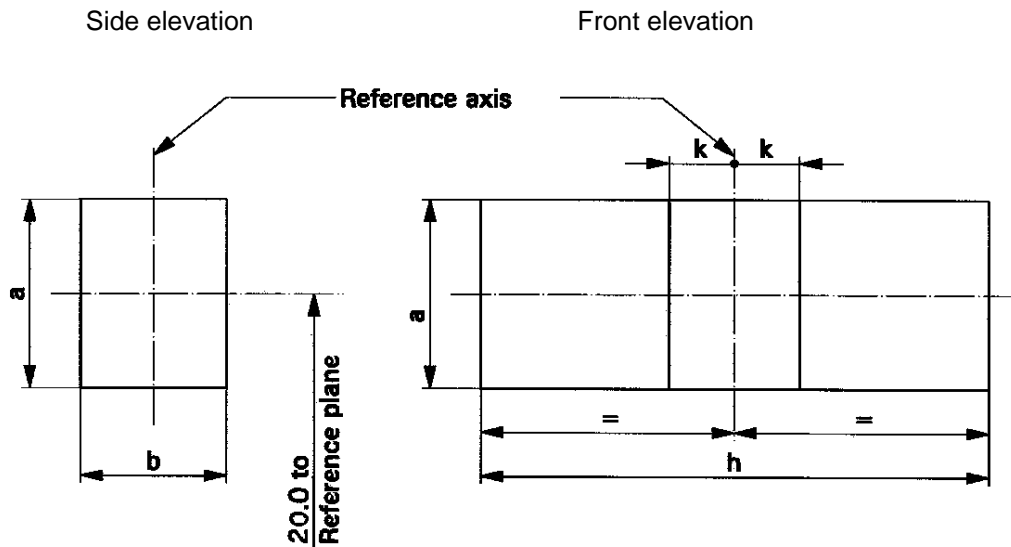

Reference	a	b	h	k
Dimension	d + 1.0	d + 1.0	f + 1.2	0.50

d = actual filament diameter
 f = actual filament length

Test procedures and requirements.

1. The filament lamp is placed in a holder capable of being rotated about its axis and having either a calibrated scale or fixed stops corresponding to the angular displacement tolerance limits. The holder is then so rotated that an end view of the filament is seen on the screen on to which the image of the filament is projected. The end view of the filament shall be obtained within the angular displacements tolerance limits.
2. Side elevation
 The filament lamp placed with the cap down, the reference axis vertical and the filament seen end-on, the projection of the filament shall lie entirely within a rectangle of height "a" and width "b", having its centre at the theoretical position of the centre of the filament.
3. Front elevation
 The filament lamp placed with the cap down and the reference axis vertical, the filament lamp being viewed in a direction at right angles to the filament axis:
 - 3.1. the projection of the filament shall lie entirely within a rectangle of height "a" and width "h", having its centre at the theoretical position of the centre of the filament;
 - 3.2. the centre of the filament shall not be offset by more than distance "k" from the reference axis.

CATEGORIES H27W/1 AND H27W/2

Sheet H27W/1

The drawings are intended only to illustrate the essential dimensions (in mm) of the filament lamp

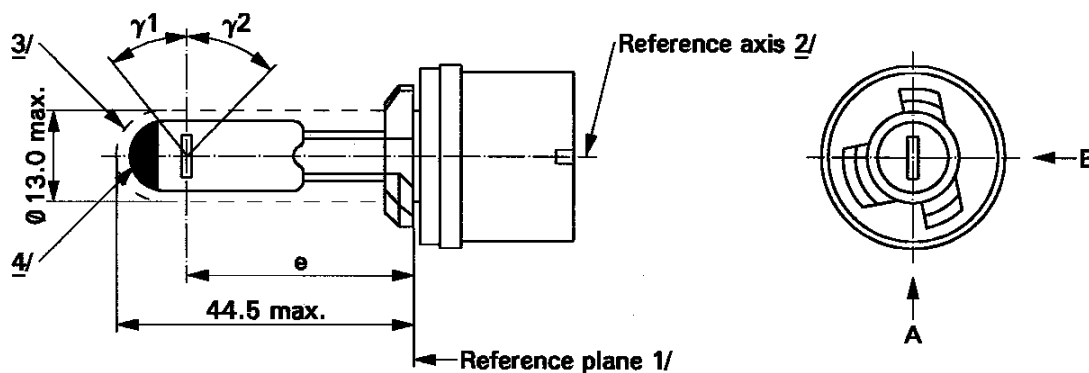

Category H27W/1

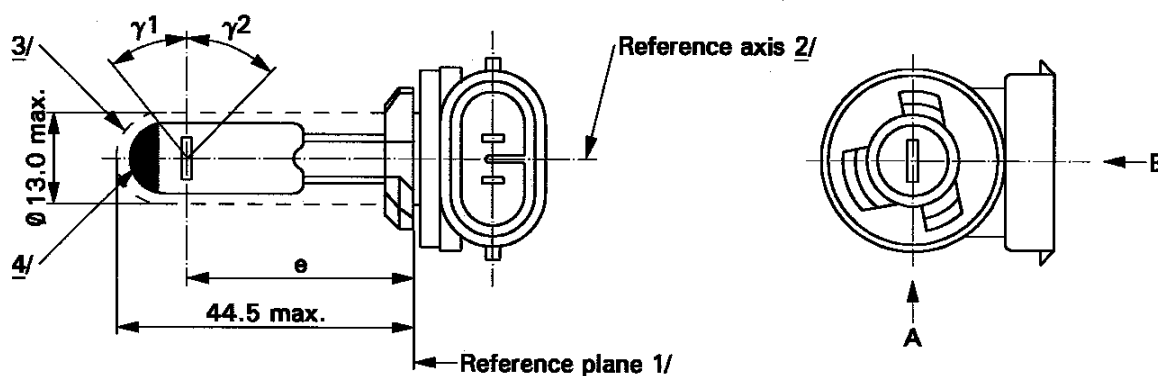

Category H27W/2

- 1/ The reference plane is defined by the plane formed by the underside of the bevelled lead-in flange of the cap.
- 2/ The reference axis is perpendicular to the reference plane and passes through the centre of the 13.10 mm cap diameter.
- 3/ Glass bulb and supports shall not exceed the size of a theoretical cylinder centred on the reference axis.
- 4/ The obscuration shall extend over the whole bulb top including the bulb cylindrical portion up to the intersection with γ_1 .

CATEGORIES H27W/1 AND H27W/2

Sheet H27W/2

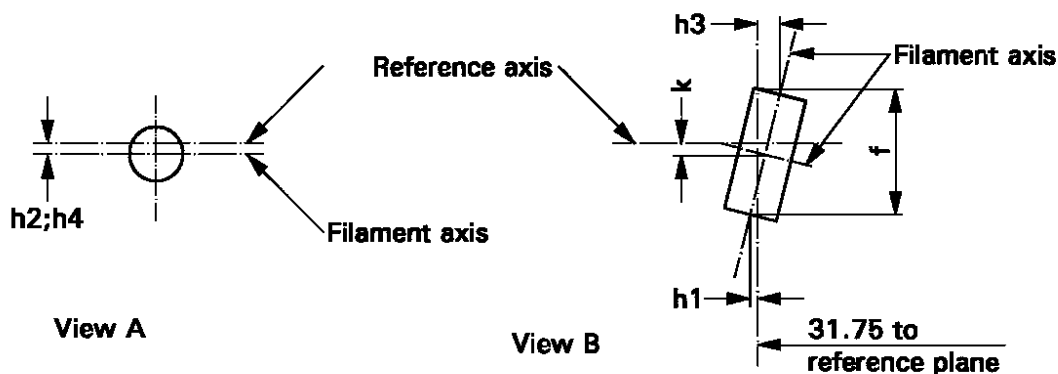

Filament dimensions and position
(Dimensions f for all filament lamps)
(Dimensions h1, h2, h3, h4 and k for standard filament lamps only)

Dimensions in mm		Filament lamp of normal production	Standard filament lamp
e		31.75 <u>6/</u>	31.75 ± 0.25
f	<u>8/</u>	4.8 max.	4.2 ± 0.20
k		0 <u>6/</u>	0.0 ± 0.25
h1, h2, h3, h4	<u>7/</u>	0 <u>6/</u>	0.0 ± 0.25
γ1	<u>5/</u>	38° nom.	38° nom.
γ2	<u>5/</u>	44° nom.	44° nom.
Cap	H27W/1: PG13 H27W/2: PGJ13	in accordance with IEC Publication 60061 (sheet 7004-107-3)	
ELECTRICAL AND PHOTOMETRIC CHARACTERISTICS			
Rated values	Volts	12	12
	Watts	27	27
Test voltage	Volts	13.5	13.5
Objective values	Watts	31 max.	31 max.
	Luminous flux	477 ± 15 %	
Reference luminous flux: 477 lm at approximately 13.5 V			

- 5/ Glass bulb shall be optically distortion free within the angles γ1 and γ2. This requirement applies to the whole bulb circumference within the angles γ1 and γ2.
- 6/ To be checked by means of a "Box System", sheet H27W/3.
- 7/ For standard filament lamps, the points to be measured are those where the projection of the outside of the end turns crosses the filament axis.
- 8/ The ends of the filament are defined by the intersections of the outside of the first and of the last light emitting turn, respectively, with the plane parallel to and 31.75 mm from the reference plane.

Screen projection requirements

This test is used to determine, by checking whether the filament is correctly positioned relative to the reference axis and reference plane, whether a filament lamp complies with the requirements.

Dimensions in mm

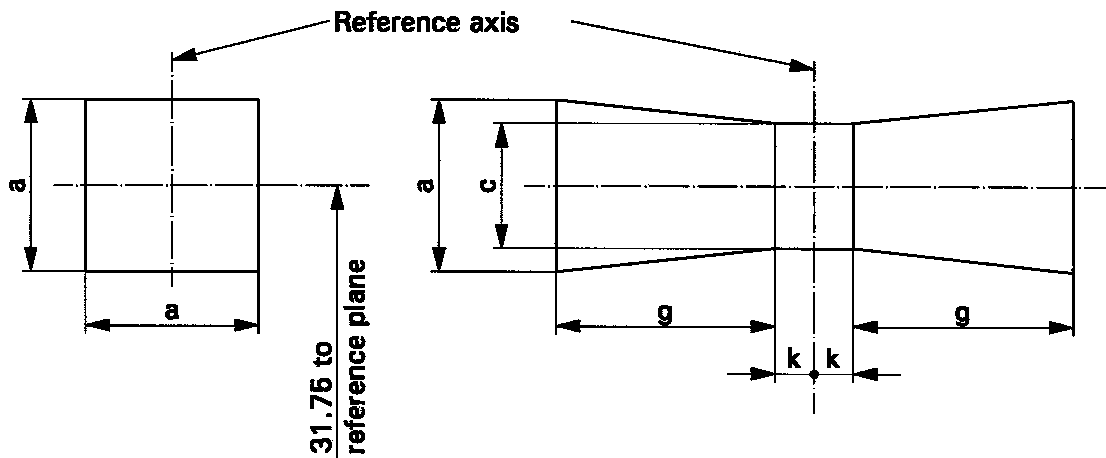

Reference	a	c	k	g
Dimensions	$d + 1.2$	$d + 1.0$	0.5	2.4

d = actual diameter of filament

The filament shall lie entirely within the limits shown.

The centre of the filament shall lie within the limits of dimension k .

CATEGORIES HB3 AND HB3A

Sheet HB3/1

The drawings are intended only to illustrate the essential dimensions (in mm) of the filament lamp

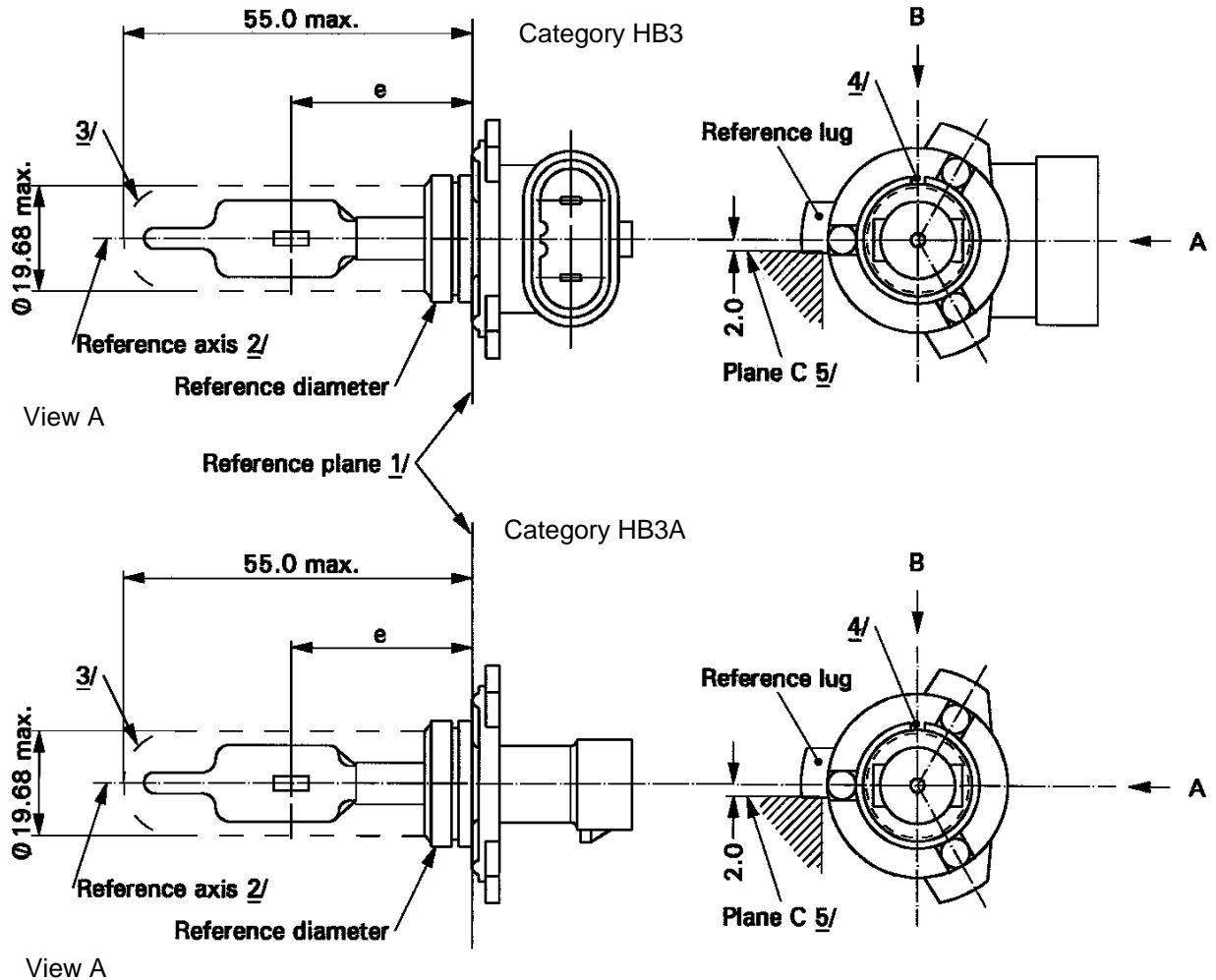

- 1/ The reference plane is the plane defined by the meeting points of cap-holder fit.
- 2/ The reference axis is perpendicular to the reference plane and concentric with the reference diameter of the cap.
- 3/ Glass bulb and supports shall not exceed the envelope and shall not interfere with insertion past the lamp key.
- 4/ The keyway is mandatory.
- 5/ The filament lamp shall be rotated in the measuring holder until the reference lug contacts plane C of the holder.

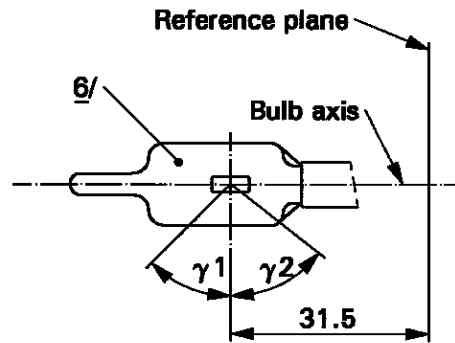

Distortion free area 7/

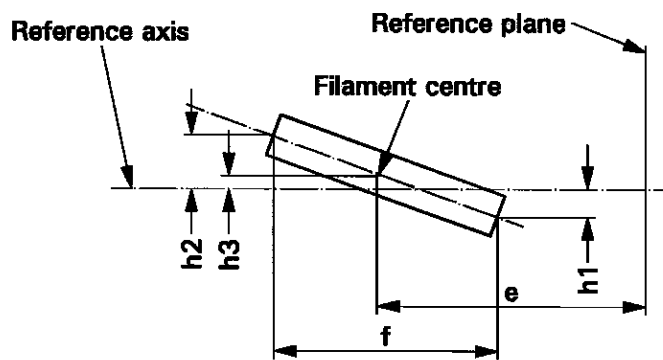

Filament position and dimensions

- 6/ The bulb shall be colourless or yellow.
- 7/ Glass bulb periphery shall be optically distortion-free axially within the angles γ_1 and γ_2 . This requirement applies to the whole bulb circumference within the angles γ_1 and γ_2 .

CATEGORIES HB3 AND HB3A

Sheet HB3/3

Dimensions in mm <u>12/</u>		Tolerances		
		Filament lamps of normal production	Standard filament lamp	
e	<u>9/ 11/</u>	31.5	<u>10/</u>	± 0.16
f	<u>9/ 11/</u>	5.1	<u>10/</u>	± 0.16
h1, h2		0	<u>10/</u>	± 0.15 <u>8/</u>
h3		0	<u>10/</u>	± 0.08 <u>8/</u>
γ1		45° min.	-	-
γ2		52° min.	-	-
Cap P20d in accordance with IEC Publication 60061 (sheet 7004-31-2) <u>13/</u>				
ELECTRICAL AND PHOTOMETRIC CHARACTERISTICS				
Rated values	Volts		12	12
	Watts		60	60
Test voltage	Volts		13.2	13.2
Objective values	Watts		73 max.	73 max.
	Luminous flux		1,860 ± 12 %	
Reference luminous flux: 1,300 lm at approximately 12 V				

- 8/ The eccentricity is measured only in viewing directions */ A and B as shown in the figure on sheet HB3/1. The points to be measured are those where the projection of the outside of the end turns nearest to or furthest from the reference plane crosses the filament axis.
- 9/ The viewing direction is direction */ B as shown in the figure on sheet HB3/1.
- 10/ To be checked by means of a "Box-System"; sheet HB3/4. */
- 11/ The ends of the filament are defined as the points where, when the viewing direction */ as defined in note 9/ above, the projection of the outside of the end turns crosses the filament axis.
- 12/ Dimensions shall be checked with O-ring removed.
- 13/ Filament lamp HB3 shall be equipped with the right-angle cap and filament lamp HB3A with the straight cap.

*/ Manufacturers may choose another set of perpendicular viewing directions. The viewing directions specified by the manufacturer are to be used by the testing laboratory when checking filament dimensions and position.

Screen projection requirements

This test is used to determine, by checking whether the filament is correctly positioned relative to the reference axis and reference plane, whether a filament lamp complies with the requirements.

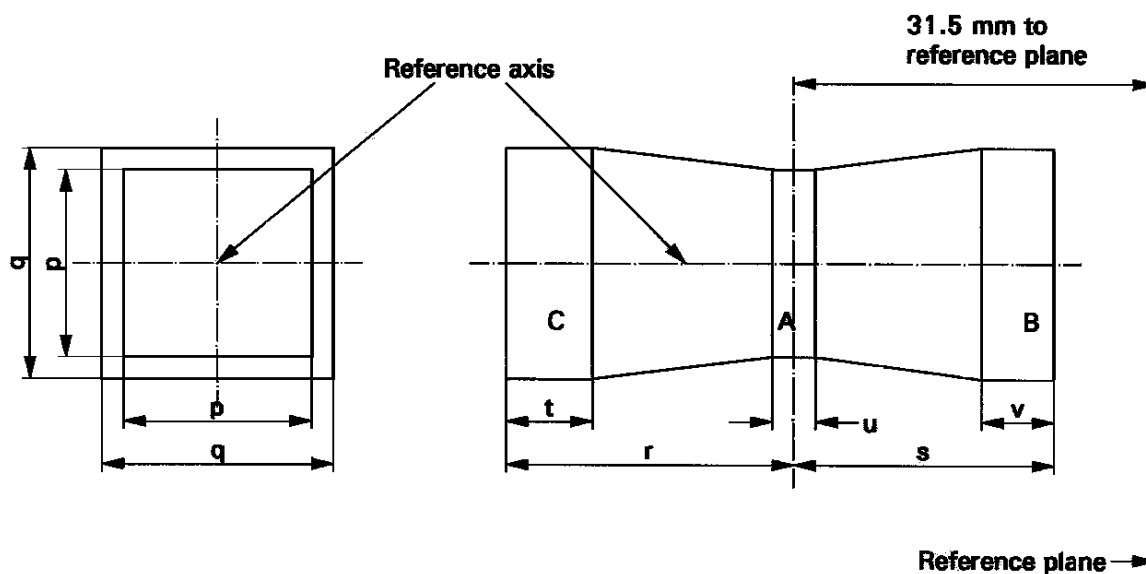

	p	q	r	s	t	u	v
12 V	1.3 d	1.6 d	3.0	2.9	0.9	0.4	0.7

d = diameter of filament

The filament position is checked solely in directions A and B as shown on sheet HB3/1.

The filament shall lie entirely within the limits shown.

The beginning of the filament as defined on sheet HB3/3, note 11/, shall lie in volume "B" and the end of the filament in volume "C".

Volume "A" does not involve any filament centre requirement.

CATEGORIES HB4 AND HB4A

Sheet HB4/1

The drawings are intended only to illustrate the essential dimensions (in mm) of the filament lamp

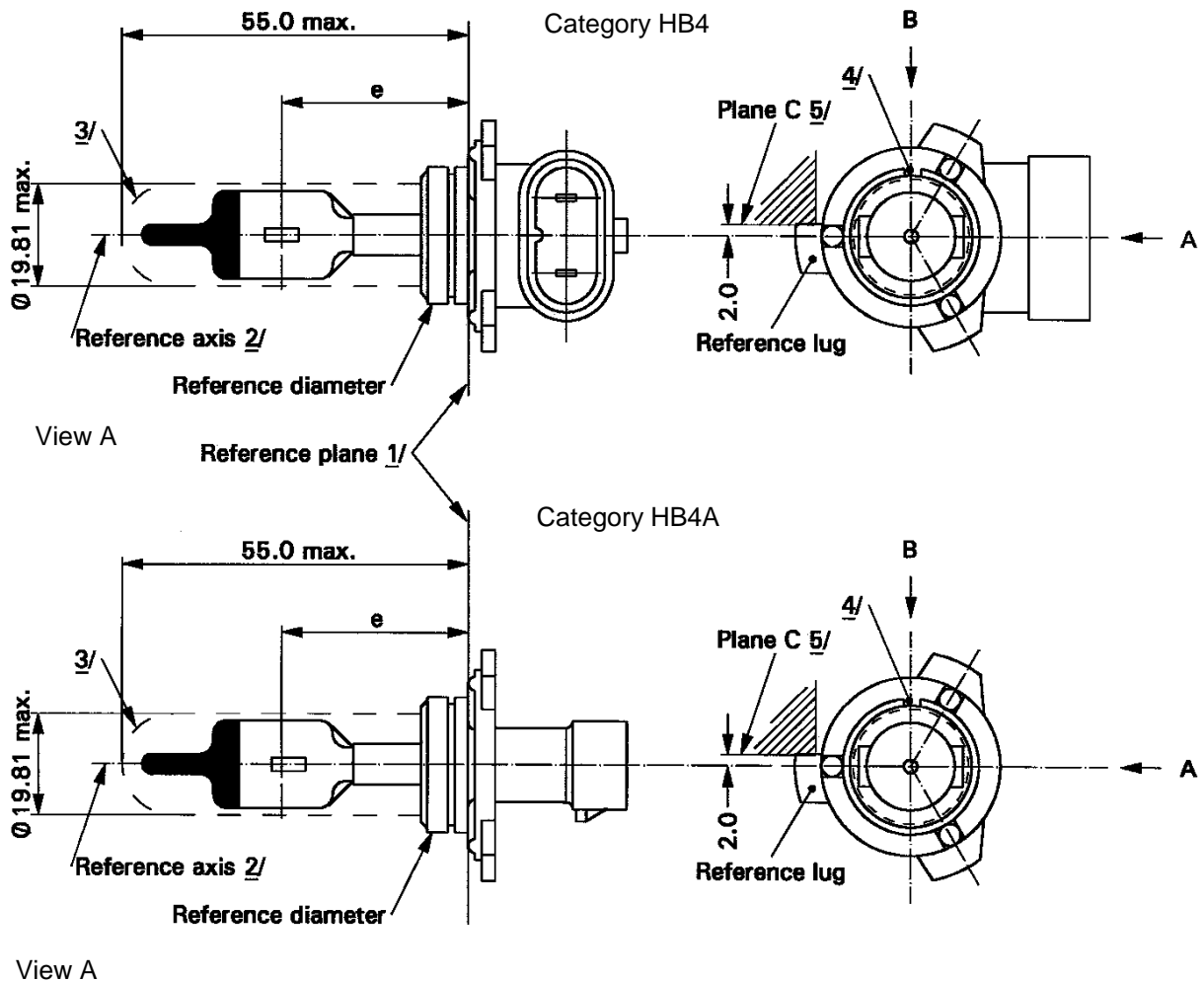

- View A
- 1/ The reference plane is the plane defined by the meeting points of cap-holder fit.
 - 2/ The reference axis is perpendicular to the reference plane and concentric with the reference diameter of the cap.
 - 3/ Glass bulb and supports shall not exceed the envelope and shall not interfere with insertion past the lamp key. The envelope is concentric to the reference axis.
 - 4/ The keyway is mandatory.
 - 5/ The filament shall be rotated in the measuring holder until the reference lug contacts plane C of the holder.

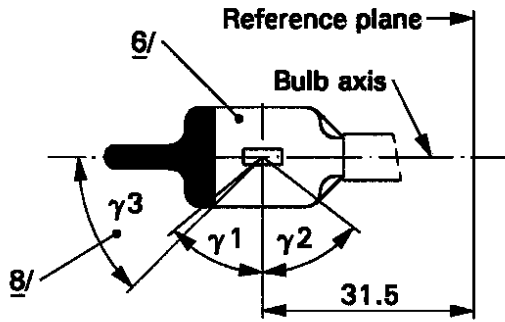

Distortion free area 7/ and black top 8/

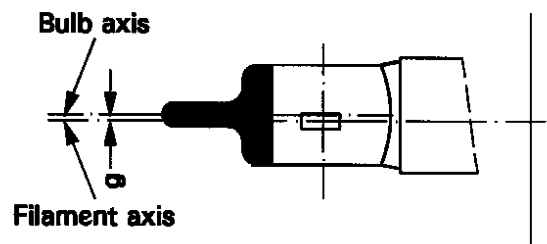

Bulb eccentricity

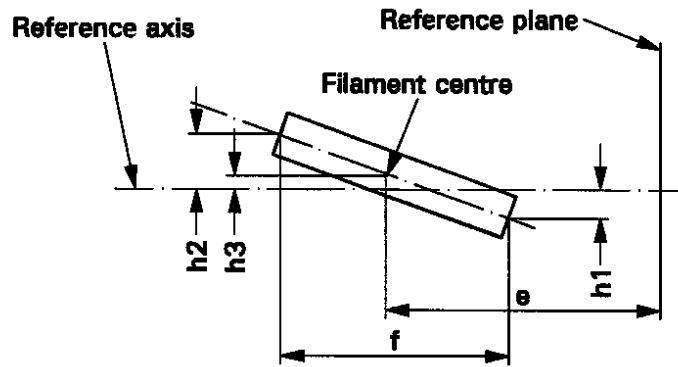

Filament position and dimensions

- 6/ The bulb shall be colourless or yellow.
- 7/ Glass bulb periphery shall be optically distortion-free axially within the angles γ_1 and γ_2 . This requirement applies to the whole bulb circumference within the angles γ_1 and γ_2 .
- 8/ The obscuration shall extend to at least angle γ_3 and shall be at least as far as the undistorted part of the bulb defined by angle γ_1 .

CATEGORIES HB4 AND HB4A

Sheet HB4/3

Dimensions in mm <u>13/</u>		Tolerances		
		Filament lamps of normal production	Standard filament lamp	
e	<u>10/ 12/</u>	31.5	<u>11/</u>	± 0.16
f	<u>10/ 12/</u>	5.1	<u>11/</u>	± 0.16
h1, h2		0	<u>11/</u>	± 0.15 <u>9/</u>
h3		0	<u>11/</u>	± 0.08 <u>9/</u>
g	<u>10/</u>	0.75	± 0.5	± 0.3
γ1		50° min.	-	-
γ2		52° min.	-	-
γ3		45°	± 5°	± 5°
Cap P22d in accordance with IEC Publication 60061 (sheet 7004-32-2) <u>14/</u>				
ELECTRICAL AND PHOTOMETRIC CHARACTERISTICS				
Rated values	Volts		12	12
	Watts		51	51
Test voltage	Volts		13.2	13.2
Objective values	Watts		62 max.	62 max.
	Luminous flux		1,095 ± 15 %	
Reference luminous flux: 825 lm at approximately 12 V				

- 9/ The eccentricity is measured only in viewing directions */ A and B as shown in the figure on sheet HB4/1. The points to be measured are those where the projection of the outside of the end turns nearest to or furthest from the reference plane crosses the filament axis.
- 10/ The viewing direction is direction */ B as shown in the figure on sheet HB4/1.
- 11/ To be checked by means of a "Box-System"; sheet HB4/4. */
- 12/ The ends of the filament are defined as the points where, when the viewing direction */ as defined in note 10/ above, the projection of the outside of the end turns crosses the filament axis.
- 13/ Dimensions shall be checked with O-ring removed.
- 14/ Filament lamp HB4 shall be equipped with the right-angle cap and filament lamp HB4A with the straight cap.

*/ Manufacturers may choose another set of perpendicular viewing directions. The viewing directions specified by the manufacturer are to be used by the testing laboratory when checking filament dimensions and position.

CATEGORIES HB4 AND HB4A

Sheet HB4/4

Screen projection requirements

This test is used to determine, by checking whether the filament is correctly positioned relative to the reference axis and reference plane, whether a filament lamp complies with the requirements.

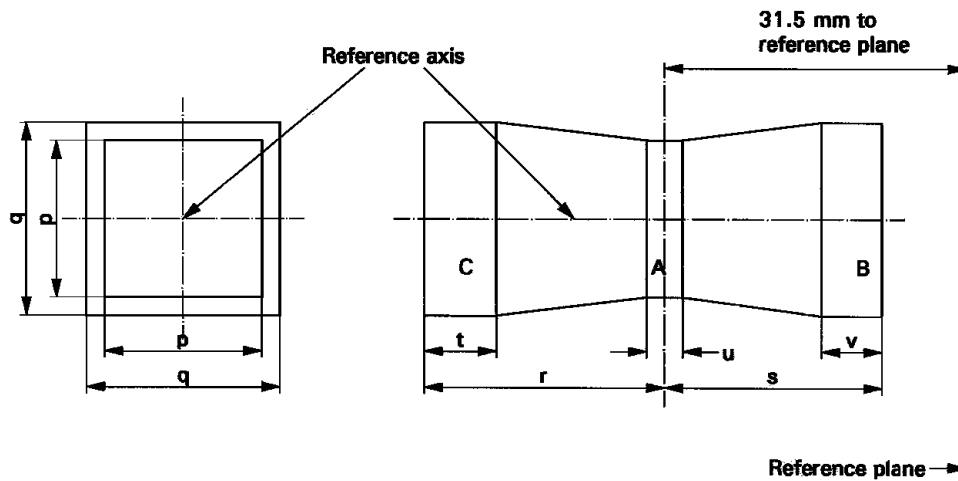

	p	q	r	s	t	u	v
12 V	1.3 d	1.6 d	3.0	2.9	0.9	0.4	0.7

d = diameter of filament

The filament position is checked solely in directions A and B as shown on sheet HB4/1.

The filament shall lie entirely within the limits shown.

The beginning of the filament as defined on sheet HB4/3 note 12/ shall lie in volume "B" and the end of the filament in volume "C".

Volume "A" does not involve any filament centre requirement.

CATEGORY HIR1

Sheet HIR1/1

The drawings are intended only to illustrate the essential dimensions (in mm) of the filament lamp

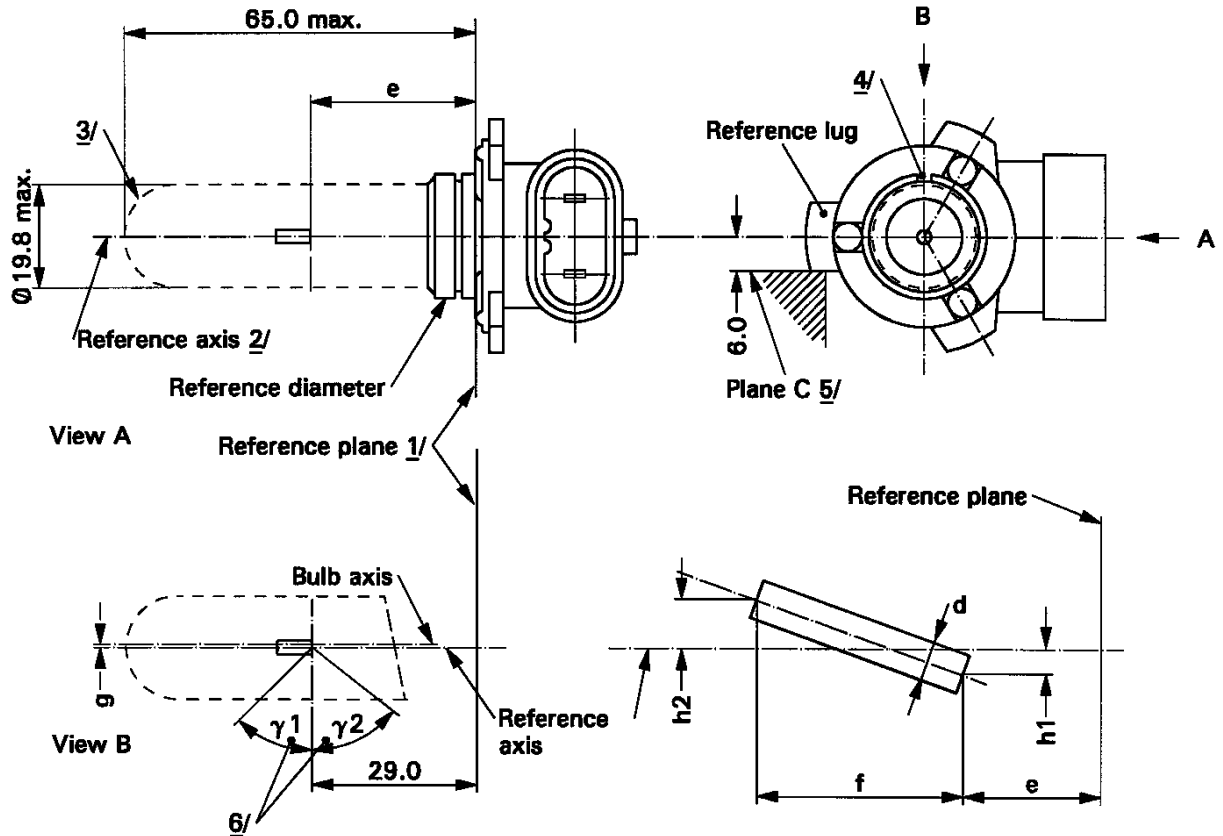

- 1/ The reference plane is the plane defined by the three supporting bosses on the cap flange.
- 2/ The reference axis is perpendicular to the reference plane and concentric with the reference diameter of the cap.
- 3/ Glass bulb and supports shall not exceed the envelope. The envelope is concentric to the reference axis.
- 4/ The keyway is mandatory.
- 5/ The filament shall be rotated in the measuring holder until the reference lug contacts plane C of the holder.
- 6/ Glass bulb periphery shall be optically distortion-free axially within the angles γ_1 and γ_2 . This requirement applies to the whole bulb circumference within the angles γ_1 and γ_2 .

CATEGORY HIR1

Sheet HIR1/2

Dimensions in mm <u>11/</u>		Tolerances		
		Filament lamps of normal production	Standard filament lamp	
e	<u>8/ 10/</u>	29	<u>9/</u>	± 0.16
f	<u>8/ 10/</u>	5.1	<u>9/</u>	± 0.16
g	<u>8/</u>	0	+ 0.7/ - 0.0	+ 0.4/ - 0.0
h1, h2		0	<u>9/</u>	± 0.15 <u>7/</u>
d		1.6 max.		
γ1		50° min.	-	-
γ2		50° min.	-	-
Cap PX20d in accordance with IEC Publication 60061 (sheet 7004-31-2)				
ELECTRICAL AND PHOTOMETRIC CHARACTERISTICS				
Rated values	Volts		12	12
	Watts		65	65
Test voltage	Volts		13.2	13.2
Objective values	Watts		73 max.	73 max.
	Luminous flux		2,500 ± 15 %	
Reference luminous flux: 1,840 lm at approximately 12 V				

- 7/ The eccentricity is measured only in viewing directions A and B as shown in the figure on sheet HIR1/1. The points to be measured are those where the projection of the outside of the end turns nearest to or furthest from the reference plane crosses the filament axis.
- 8/ The viewing direction is direction B as shown in the figure on sheet HIR1/1.
- 9/ To be checked by means of a "Box-System"; sheet HIR1/3.
- 10/ The ends of the filament are defined as the points where, when the viewing direction as defined in note 8/ above, the projection of the outside of the end turns crosses the filament axis.
- 11/ Dimensions shall be checked with O-ring mounted.

CATEGORY HIR1

Sheet HIR1/3

Screen projection requirements

This test is used to determine, by checking whether the filament is correctly positioned relative to the reference axis and reference plane, whether a filament lamp complies with the requirements.

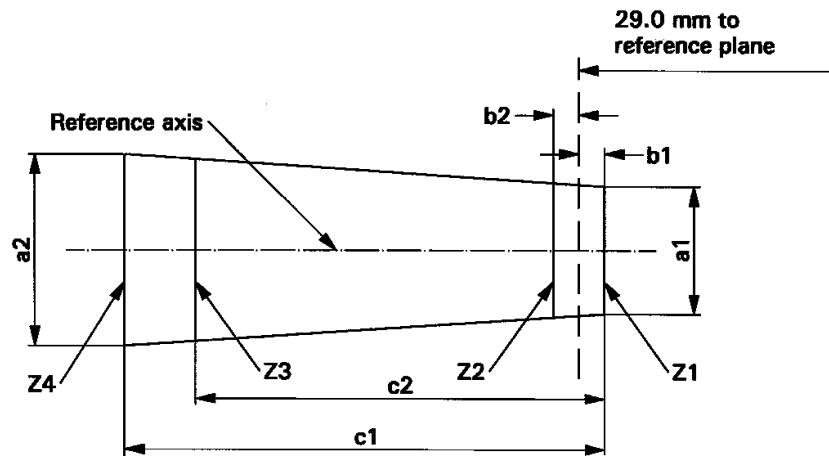

	a1	a2	b1	b2	c1	c2
12 V	$d + 0.4$	$d + 0.8$	0.35		6.1	5.2

d = diameter of filament

The filament position is checked solely in directions A and B as shown on sheet HIR1/1.

The ends of the filament as defined on sheet HIR1/2 note 10/ shall lie between lines Z_1 and Z_2 and between lines Z_3 and Z_4 .

CATEGORY HIR2

Sheet HIR2/1

The drawings are intended only to illustrate the essential dimensions (in mm) of the filament lamp

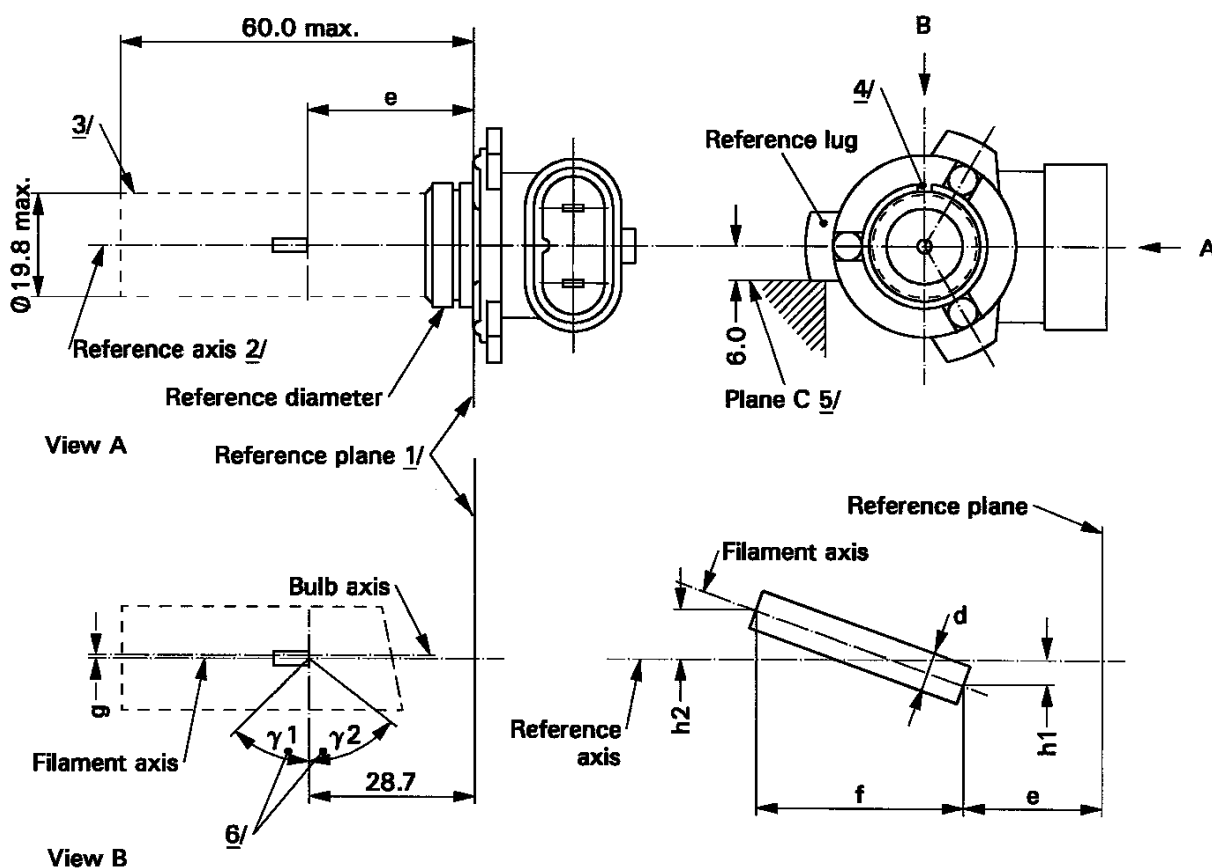

- 1/ The reference plane is the plane defined by the three meeting points of the cap holder fit.
- 2/ The reference axis is perpendicular to the reference plane and passes through the centre of the reference diameter of the cap.
- 3/ Glass bulb and supports shall not exceed the envelope. The envelop is concentric to the reference axis.
- 4/ The keyway is mandatory.
- 5/ The filament lamp shall be rotated in the measuring holder until the reference lug contacts plane C of the holder.
- 6/ Glass bulb periphery shall be optically distortion-free axially within the angles γ_1 and γ_2 . This requirement applies to the whole bulb circumference within the angles γ_1 and γ_2 .

CATEGORY HIR2

Sheet HIR2/2

Dimensions in mm <u>11/</u>		Tolerances		
		Filament lamps of normal production	Standard filament lamp	
e	<u>8/ 10/</u>	28.7	<u>9/</u>	± 0.16
f	<u>8/ 10/</u>	5.3	<u>9/</u>	± 0.16
g	<u>8/</u>	0	+ 0.7 / - 0.0	+ 0.4 / - 0.0
h1, h2		0	<u>9/</u>	± 0.15 <u>7/</u>
d		1.6 max.	-	-
γ1		50° min.	-	-
γ2		50° min.	-	-
Cap PX22d in accordance with IEC Publication 60061 (sheet 7004-32-2)				
ELECTRICAL AND PHOTOMETRIC CHARACTERISTICS				
Rated values	Volts		12	12
	Watts		55	55
Test voltage	Volts		13.2	13.2
Objective values	Watts		63 max.	63 max.
	Luminous flux		1,875 ± 15 %	
Reference luminous flux: 1,355 lm at approximately 12 V				

- 7/ The eccentricity is measured only in viewing directions A and B as shown in the figure on sheet HIR2/1. The points to be measured are those where the projection of the outside of the end turns nearest to or furthest from the reference plane crosses the filament axis.
- 8/ The viewing direction is direction B as shown in the figure on sheet HIR2/1.
- 9/ To be checked by means of a "Box-System"; sheet HIR2/3.
- 10/ The ends of the filament are defined as the points where, when the viewing direction as defined in note 8/ above, the projection of the outside of the end turns crosses the filament axis.
- 11/ Dimensions shall be checked with O-ring removed.

Screen projection requirements

This test is used to determine, by checking whether the filament is correctly positioned relative to the reference axis and reference plane, whether a filament lamp complies with the requirements.

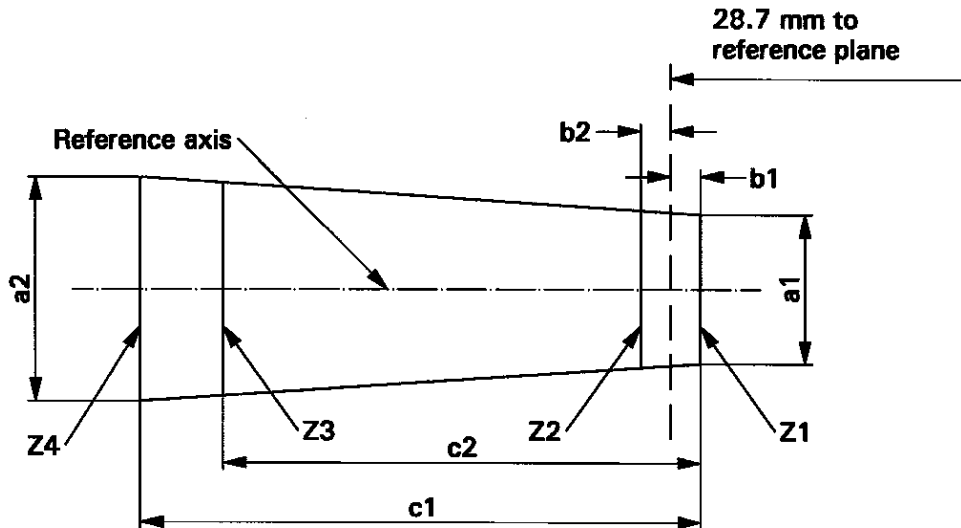

	a1	a2	b1	b2	c1	c2
12 V	$d + 0.4$	$d + 0.8$	0.35		6.6	5.7

d = diameter of filament

The filament position is checked solely in directions A and B as shown on sheet HIR2/1.

The ends of the filament as defined on sheet HIR2/2 note 10/ shall lie between lines Z1 and Z2 and between lines Z3 and Z4.

CATEGORY HS1

Sheet HS1/1

The drawings are intended only to illustrate the essential dimensions (in mm) of the filament lamp

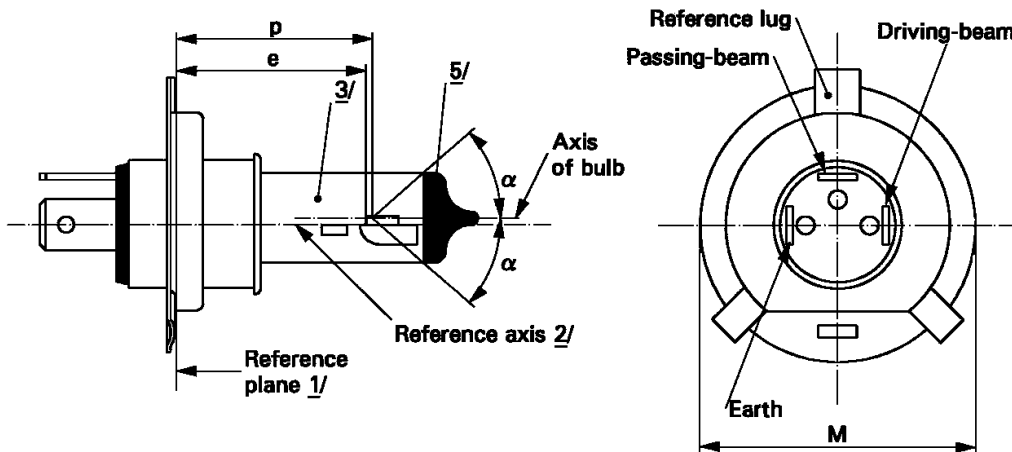

Figure 1 Main drawing

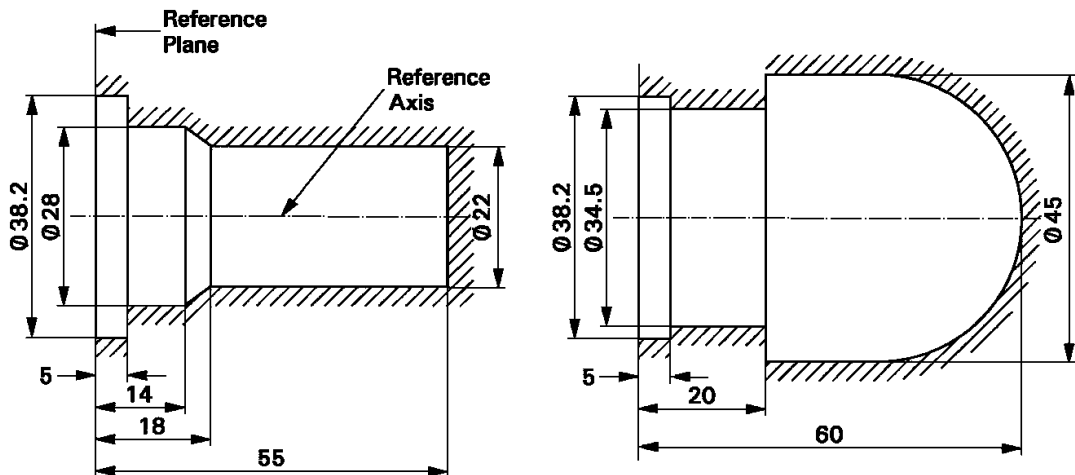

Figure 2

Maximum lamp outlines 4/

Figure 3

- 1/ The reference plane is the plane formed by the seating points of the three lugs of the cap ring.
- 2/ The reference axis is perpendicular to the reference plane and passes through the centre of the circle of diameter "M".
- 3/ The bulb shall be colourless or selective-yellow.
- 4/ The bulb and supports shall not exceed the envelope as in Figure 2. However, where a selective-yellow outer bulb is used the bulb and supports shall not exceed the envelope as in Figure 3.
- 5/ The obscuration shall extend at least as far as the cylindrical part of the bulb. It shall also overlap the internal shield when the latter is viewed in a direction perpendicular to the reference axis.

CATEGORY HS1

Sheet HS1/2

Dimensions in mm		Filament lamps of normal production				Standard filament lamp	
		6 V		12 V		12 V	
e		28.5 + 0.45/ - 0.25				28.5 + 0.20/-0.00	
p		28.95				28.95	
α		max. 40°				max. 40°	
Cap PX43t in accordance with IEC Publication 60061 (sheet 7004-34-2)							
ELECTRICAL AND PHOTOMETRIC CHARACTERISTICS							
Rated values	Volts	6 <u>6/</u>		12 <u>6/</u>		12 <u>6/</u>	
	Watts	35	35	35	35	35	35
Test voltage	Volts	6.3		13.2		13.2	
Objective values	Watts	35	35	35	35	35	35
	±%	5				5	
	Luminous flux	700	440	825	525		
	±%	15					
Measuring flux <u>7/</u> lm		-		-	450		
Reference luminous flux at approximately 12 V						700	450

6/ The values indicated in the left hand column relate to the driving-beam. Those indicated in the right-hand column relate to the passing beam.

7/ Measuring luminous flux for measuring according to paragraph 3.9. of this Regulation.

CATEGORY HS1

Sheet HS1/3

Position of shield

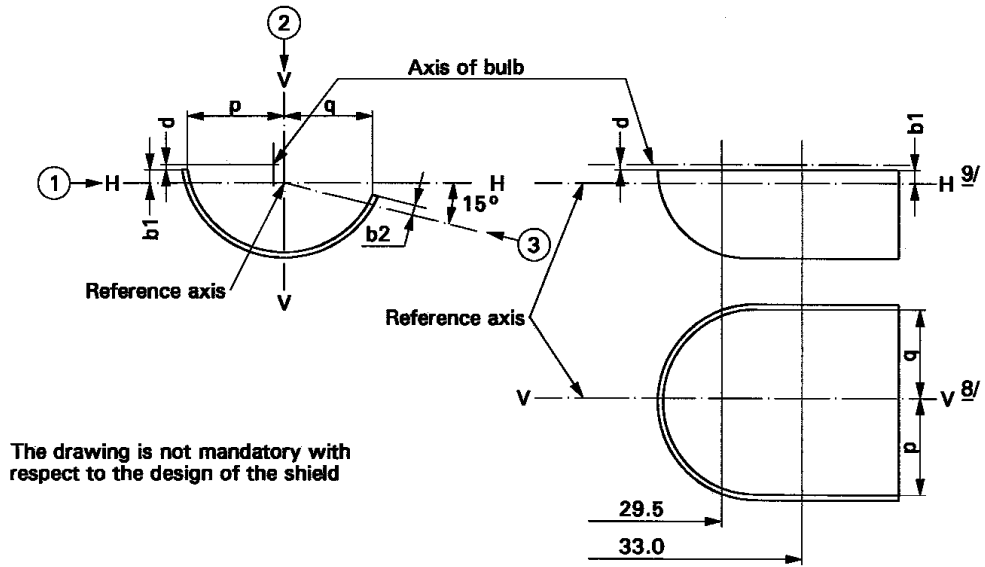

The drawing is not mandatory with respect to the design of the shield

Position of filaments

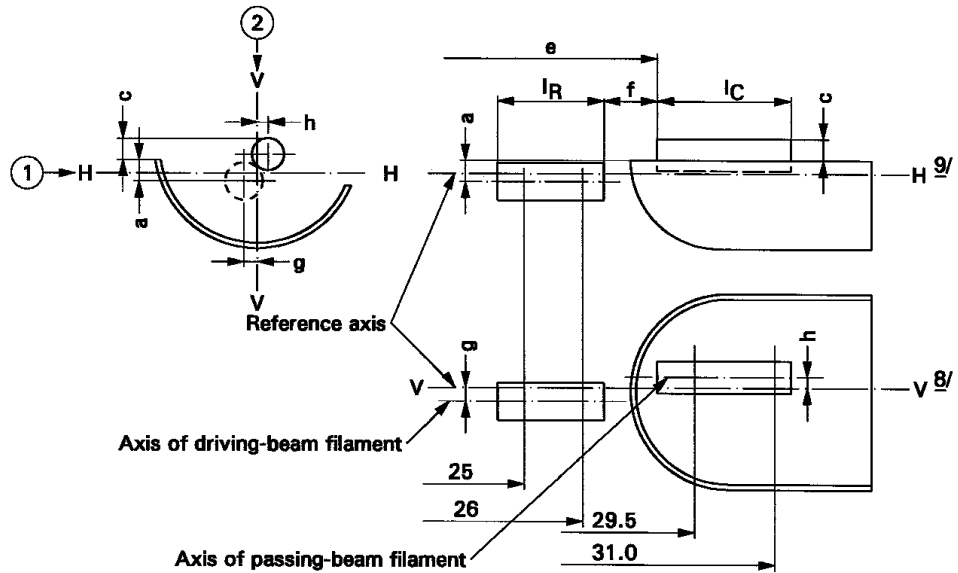

Axis of driving-beam filament

Axis of passing-beam filament

CATEGORY HS1

Sheet HS1/4

Table of the dimensions (in mm) referred to in the drawings on sheet HS1/3

Reference <u>*/</u>		Dimensions <u>**/</u>		Tolerance		
				Filaments lamps of normal production		Standard filament lamp
6 V	12 V	6 V	12 V	6 V	12 V	12 V
a/26		0.8		± 0.35		± 0.20
a/25		0.8		± 0.55		± 0.20
b1/29.5		0		± 0.35		± 0.20
b1/33		b1/29.5 mv		± 0.35		± 0.15
b2/29.5		0		± 0.35		± 0.20
b2/33		b1/29.5 mv		± 0.35		± 0.15
c/29.5		0.6		± 0.35		± 0.20
c/31		c/29.5 mv		± 0.30		± 0.15
d		min. 0.1 / max. 1.5		-		-
e <u>13/</u>		28.5		+ 0.45 / - 0.25		+0.20 / -0.00
f <u>11/ 12/ 13/</u>		1.7		+ 0.50 / -0.30		+ 0.30 / - 0.10
g/26		0		± 0.50		± 0.30
g/25		0		± 0.70		± 0.30
h/29.5		0		± 0.50		± 0.30
h/31		h/29.5 mv		± 0.30		± 0.20
lR <u>11/ 14/</u>		3.5	4.0	± 0.80		± 0.40
lC <u>11/ 12/</u>		3.3	4.5	± 0.80		± 0.35
p/33		Depends on the shape of the shield		-		-
q/33		(p+q)/2		± 0.60		± 0.30

*/ "./26" means dimension to be measured at the distance from the reference plane indicated in mm after the stroke.

**/ "29.5 mv" means the value measured at a distance of 29.5 mm from the reference plane.

CATEGORY HS1

Sheet HS1/5

- 8/ Plane V-V is the plane perpendicular to the reference plane and passing through the reference axis and through the intersection of the circle of diameter "M" with the axis of the reference lug.
- 9/ Plane H-H is the plane perpendicular to both the reference plane and plane V-V and passing through the reference axis.
- 10/ (Blank).
- 11/ The end turns of the filament are defined as being the first luminous turn and the last luminous turn that are at substantially the correct helix angle. For coiled-coil filaments, the turns are defined by the envelope of the primary coil.
- 12/ For the passing-beam filament, the points to be measured are the intersections, seen in direction 1 , of the lateral edge of the shield with the outside of the end turns defined under footnote 11/.
- 13/ "e" denotes the distance from the reference plane to the beginning of the passing beam filament as defined above.
- 14/ For the driving-beam filament the points to be measured are the intersections, seen in direction 1 , of a plane, parallel to plane H-H and situated at a distance of 0.8 mm below it, with the end turns defined under footnote 11/.

Additional explanations to sheet HS1/3

The dimensions below are measured in three directions:

- 1 for dimensions a, b1, c, d, e, f, lR and lC;
- 2 for dimensions g, h, p and q;
- 3 for dimension b2.

Dimensions p and q are measured in planes parallel to and 33 mm away from the reference plane.

Dimensions b1 and b2 are measured in planes parallel to and 29.5 mm and 33 mm away from the reference plane.

Dimensions a and g are measured in planes parallel to and 25.0 mm and 26.0 mm away from the reference plane.

Dimensions c and h are measured in planes parallel to and 29.5 mm and 31 mm away from the reference plane.

Note: For the method of measurement, see Appendix E of IEC Publication 60809.

The drawings are intended only to illustrate the essential dimensions (in mm) of the filament lamp

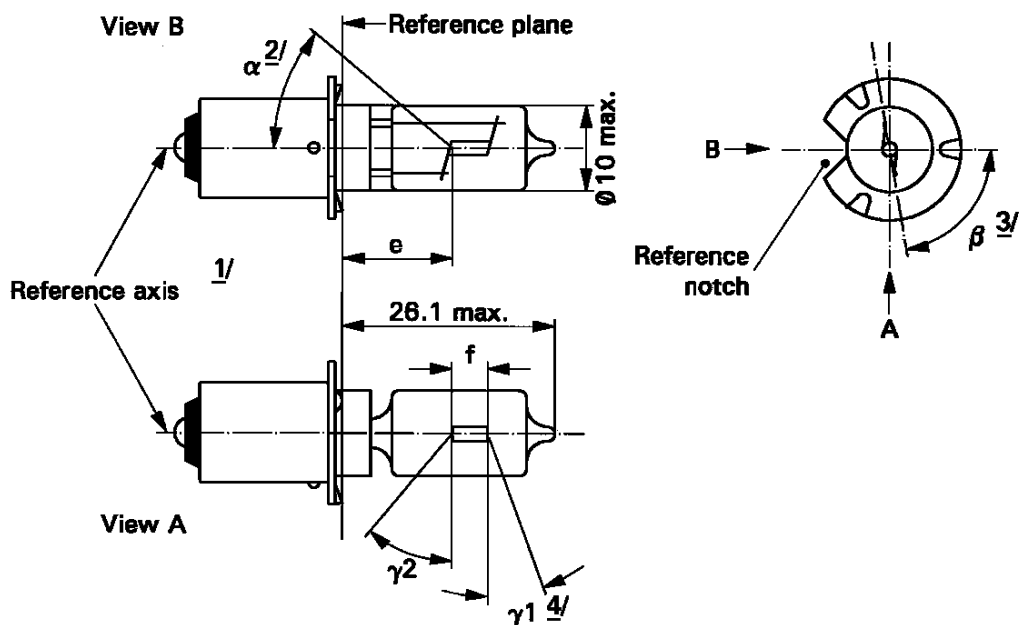

Filament position

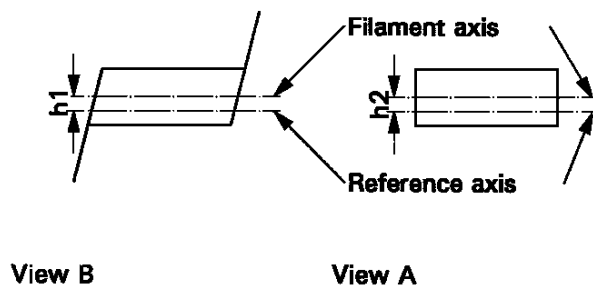

- 1/ The reference axis is perpendicular to the reference plane and passes through the intersection of this plane with the axis of the cap ring.
- 2/ All parts which may obscure the light or may influence the light beam shall lie within angle α .
- 3/ Angle β denotes the position of the plane through the inner leads with reference to the reference notch.
- 4/ In the area between the outer legs of the angles γ_1 and γ_2 , the bulb shall have no optically distorting areas and the curvature of the bulb shall have a radius not less than 50 per cent of the actual bulb diameter.

CATEGORY HS2

Sheet HS2/2

Dimensions in mm		Filament lamps of normal production			Standard filament lamp
		min.	nom.	max.	
e			11.0 <u>5/</u>		11.0 ± 0.15
f	<u>6/</u> 6 V	1.5	2.5	3.0	2.5 ± 0.15
	12 V	2.0	3.0	4.0	
h1, h2			<u>5/</u>		0 ± 0.15
α	<u>2/</u>			40°	
β	<u>3/</u>	75°	90°	105°	90° ± 5°
γ1	<u>4/</u>	15°			15° min.
γ2	<u>4/</u>	40°			40° min.
Cap PX13.5s in accordance with IEC Publication 60061 (sheet 7004-35-2)					
ELECTRICAL AND PHOTOMETRIC CHARACTERISTICS					
Rated values	Volts	6	12	6	
	Watts	15			15
Test voltage	Volts	6.75	13.5	6.75	
Objective values	Watts	15 ± 6 %			15 ± 6 %
	Luminous flux	320 ± 15 %			
Reference luminous flux: 320 lm at approximately 6.75 V					

5/ To be checked by means of the "box system", sheet HS2/3.

6/ In order to avoid rapid filament failure, the supply voltage shall not exceed 8.5 V for 6 V filament lamps and 15 V for 12 V types.

Screen projection requirements

This test is used to determine, by checking whether the filament lamp complies with the requirements by checking whether the filament lamp is correctly positioned relative to the reference axis and reference plane.

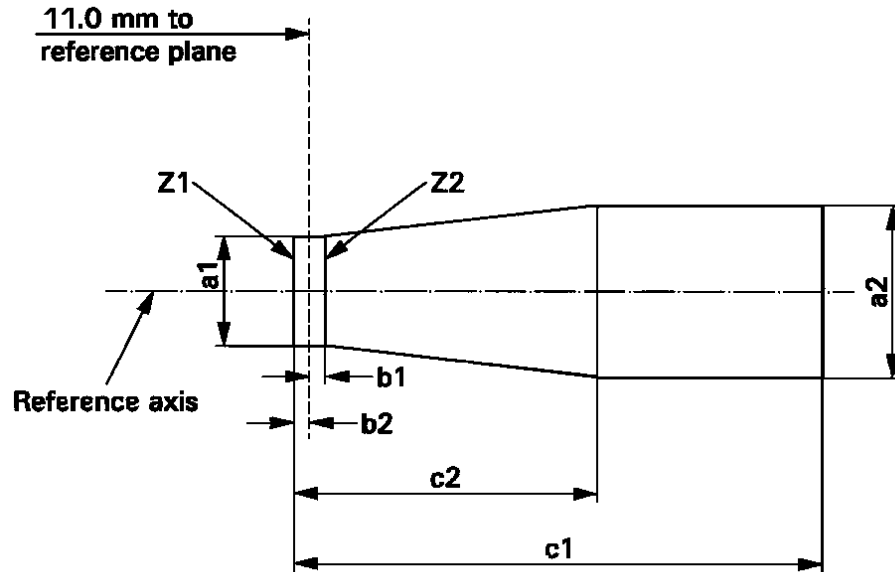

Reference	a1	a2	b1	b2	c1 (6 V)	c1 (12V)	c2
Dimension	d + 1.0	d + 1.4	0.25	0.25	4.0	4.5	1.75

d= actual filament diameter

The filament shall lie entirely within the limits shown.

The beginning of the filament shall lie between the lines Z1 and Z2.

CATEGORY HS5

Sheet HS5/1

The drawings are intended only to illustrate the essential dimensions (in mm) of the filament lamp

FILAMENT LAMP FOR MOTORCYCLES

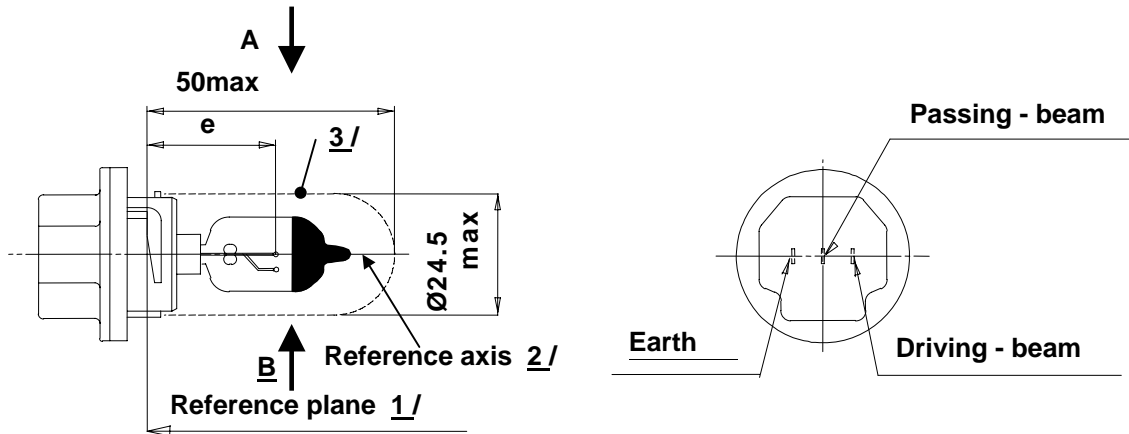

Figure 1 Main drawing

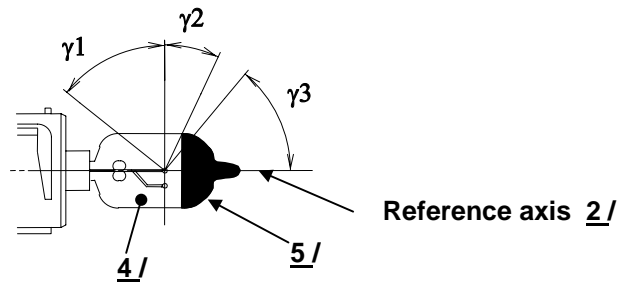
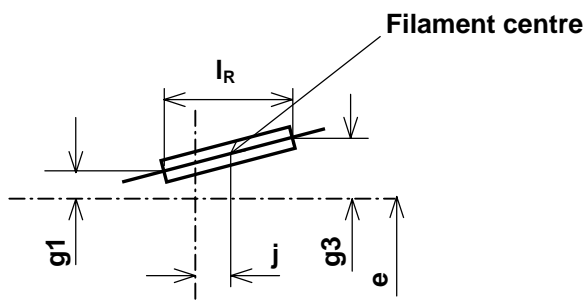

Figure 2 Distortion free area 4/ and black top 5/

- 1/ The reference plane is defined by the three ramp inside surface.
- 2/ The reference axis is perpendicular to the reference plane and passing through the centre of the 23 mm cap diameter.
- 3/ Glass bulb and supports shall not exceed the envelope as indicated in Figure 1. The envelope is concentric to the reference axis.
- 4/ Glass bulb shall be optically distortion free within the angles γ_1 and γ_2 . This requirement applies to the whole bulb circumference within the angles γ_1 and γ_2 .
- 5/ The obscuration shall extend at least to angle γ_3 and shall extend at least to the cylindrical part of the bulb on the whole top circumference.

View B of driving-beam filament



View A of passing-beam filament

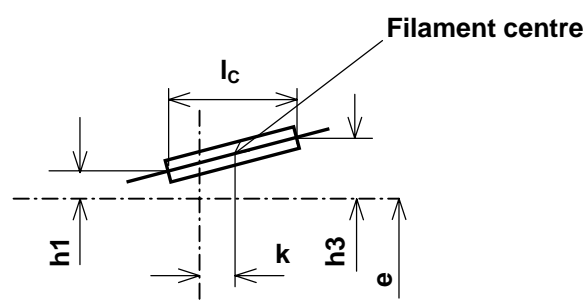

Top view of driving-beam filament

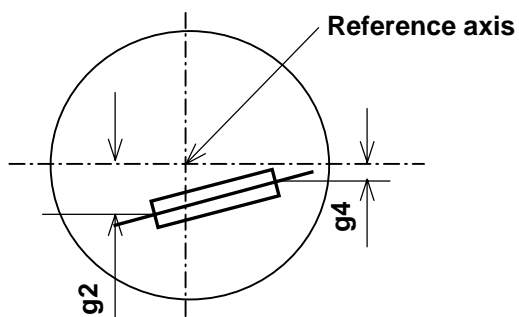

Top view of passing-beam filament

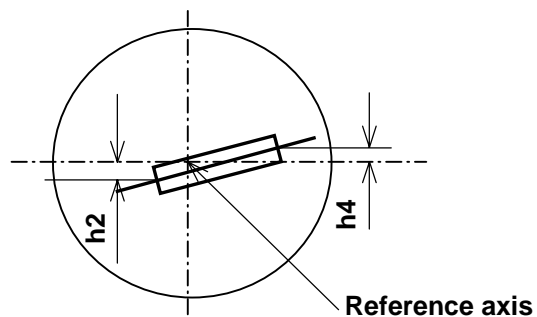

Figure 3
 Filament position and dimensions

CATEGORY HS5

Sheet HS5/3

Dimensions in mm		Filament lamps of normal production		Standard filament lamp		
		12V		12V		
e	26	<u>6/</u>		± 0.15		
l _c	<u>7/</u> 4.6			± 0.3		
k	0			± 0.2		
h1, h3	0			± 0.15		
h2, h4	0			± 0.20		
l _R	<u>7/</u> 4.6			± 0.3		
j	0			± 0.2		
g1, g3	0			± 0.30		
g2, g4	2.5			± 0.40		
γ1	50° min.			-		-
γ2	23° min.	-		-		
γ3	50° min.	-		-		
Cap P23t in accordance with IEC Publication 60061 (sheet [7004-138-1])						
ELECTRICAL AND PHOTOMETRIC CHARACTERISTICS						
Rated values	Voltage	V	12		12	
	Wattage	W	35	30	35	30
Test voltage		V	13.2		13.2	
Objective Values	Wattage	W	40 max.	37 max.	40 max.	37 max.
	Luminous flux	lm	620	515		
		±%	15	15		
Reference luminous at approximately 12V				460 lm	380 lm	

6/ To be checked by means of a "Box-System". Sheet HS5/4.

7/ The positions of the first and the last turn of the filament are defined by the intersections of the outside of the first and the outside of the last light-emitting turn, respectively, with the plane parallel to and 26 mm distant from the reference plane.

Screen projection requirement

This test is used to determine whether a filament lamp complies with the requirements by checking whether:

- (a) the passing-beam filament is correctly positioned relative to the reference axis and the reference plane; and whether
- (b) the driving-beam filament is correctly positioned relative to the passing-beam filament.

Side elevation

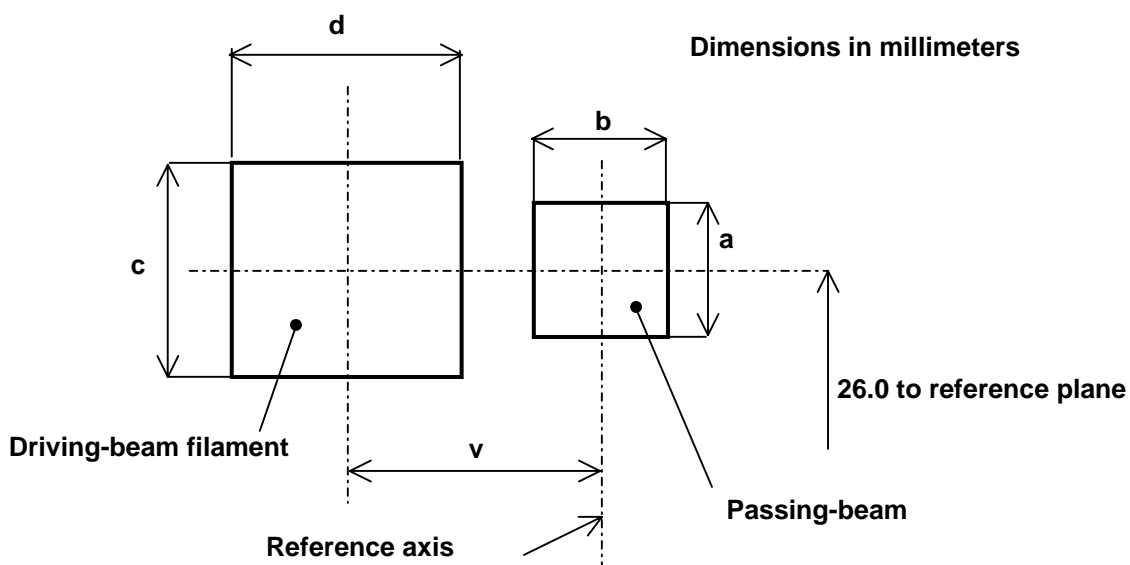

Reference	a	b	c	d	v
Dimensions	$d1+0.6$	$d1+0.8$	$d2+1.2$	$d2+1.6$	2.5

d1 : Diameter of the passing-beam filament
 d2 : Diameter of the driving-beam filament

Front elevation

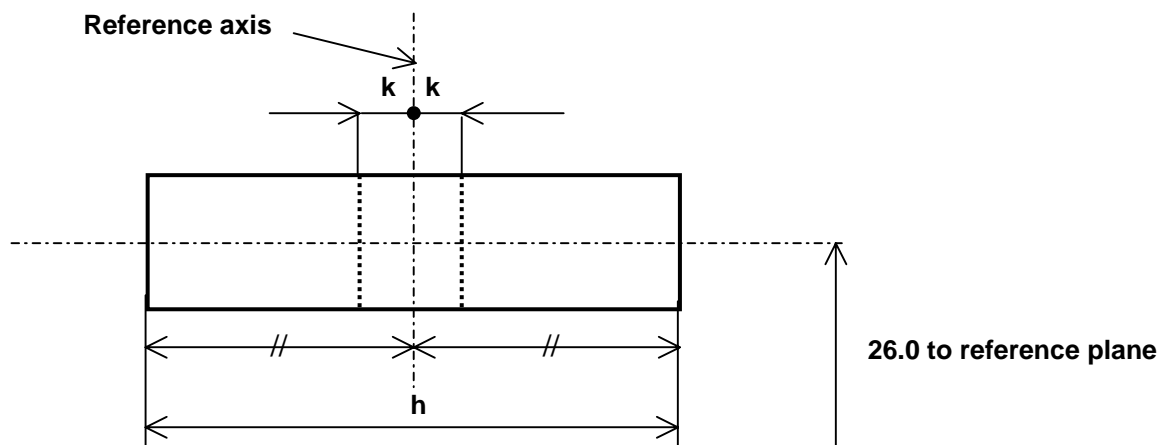

Reference	h	k
Dimensions	6.0	0.5

The filaments shall lie entirely within the limits shown.
 The centre of the filament shall lie within the limits of dimension k.

CATEGORY P13W

Sheet P13W/1

The drawings are intended only to illustrate the essential dimensions (in mm) of the filament lamp

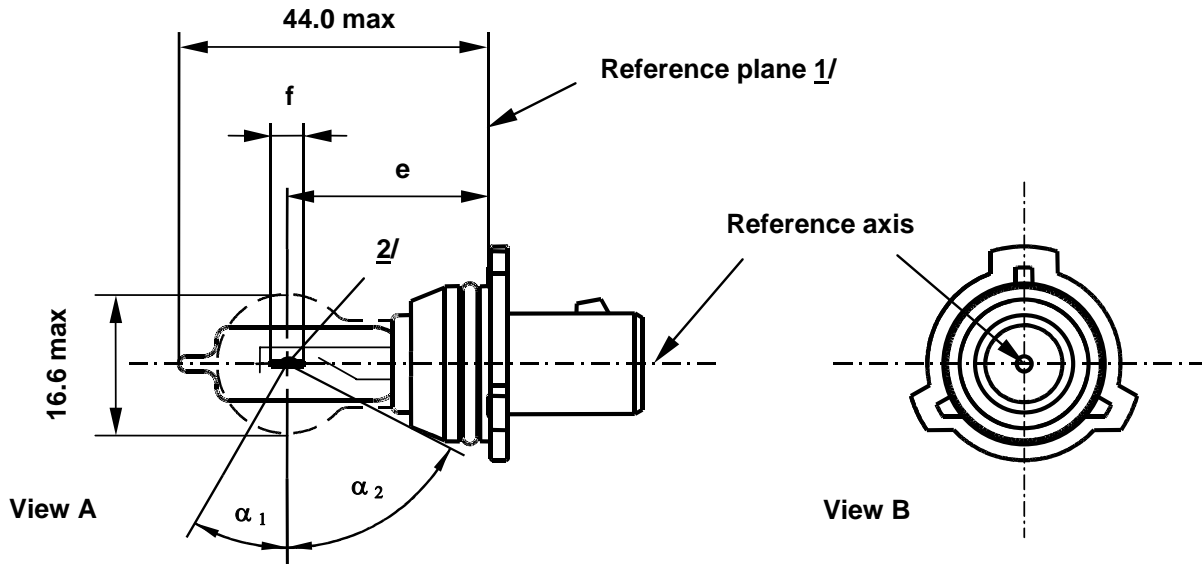

Figure 1 – Main drawing

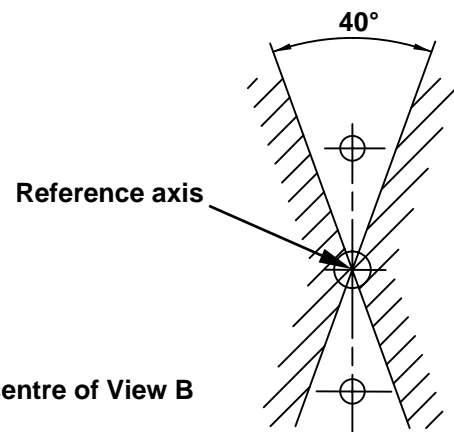

Figure 2 – Metal free zone 3/

- 1/ The reference plane is defined by the meeting points of the cap-holder fit.
- 2/ No actual filament diameter restrictions apply but the objective is $d_{max} = 1.0$ mm.
- 3/ No opaque parts other than filament turns shall be located in the shaded area indicated in Figure 2. This applies to the rotational body within the angles $\alpha_1 + \alpha_2$.

CATEGORY P13W

Sheet P13W/2

Dimensions in mm		Filament lamps of normal production		Standard filament lamp
e	<u>5/</u>	25.0	<u>4/</u>	25.0 ± 0.25
f	<u>5/</u>	4.3	<u>4/</u>	4.3 ± 0.25
α_1	<u>6/</u>	30.0° min.		30.0° min.
α_2	<u>6/</u>	58.0° min.		58.0° min.
Cap PG18.5d		in accordance with IEC Publication 60061 (sheet 7004-xxx-1)		
ELECTRICAL AND PHOTOMETRIC CHARACTERISTICS				
Rated values	Voltage	V	12	12
	Wattage	W	13	13
Test voltage		V	13.5	13.5
Objective values	Wattage	W	19 max.	19 max.
	Luminous flux	lm	250	
		±	+15% / -20%	
Reference luminous flux at approximately 13.5V				250 lm

- 4/ To be checked by means of a "Box-System"; sheet P13W/3.
- 5/ The ends of the filament are defined as the points where, when the viewing direction is perpendicular to the plane through the filament lead-in wires, the projection of the outside of the end turns crosses the filament axis.
- 6/ No part of the cap beyond the reference plane shall interfere with angle α_2 as shown in Figure 1 on sheet P13W/1. The bulb shall be optically distortion free within the angles $\alpha_1 + \alpha_2$. These requirements apply to the whole bulb circumference.

CATEGORY P13W

Sheet P13W/3

Screen projection requirements

This test is used to determine, by checking whether the filament is correctly positioned relative to the reference axis and reference plane, whether a filament lamp complies with the requirements.

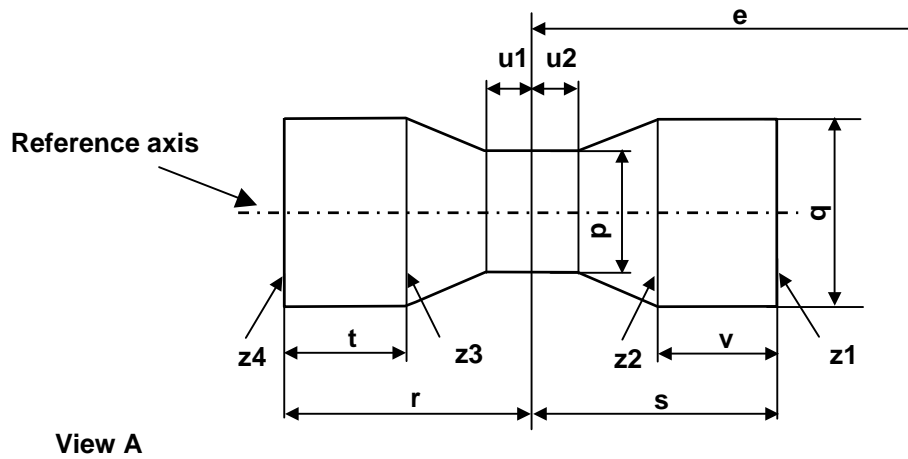

	p	q	u1,u2	r,s	t,v
Filament lamps of normal production	1.7	1.9	0.3	2.6	0.9
Standard filament lamps	1.5	1.7	0.25	2.45	0.6

The filament position is checked in two mutually perpendicular planes, one of them being the plane through the lead-in wires.

The ends of the filament as defined on sheet P13W/2, note 4/, shall lie between Z1 and Z2 and between the lines Z3 and Z4.

The filament shall lie entirely within the limits shown.

The drawings are intended only to illustrate the essential dimensions (in mm) of the filament lamp

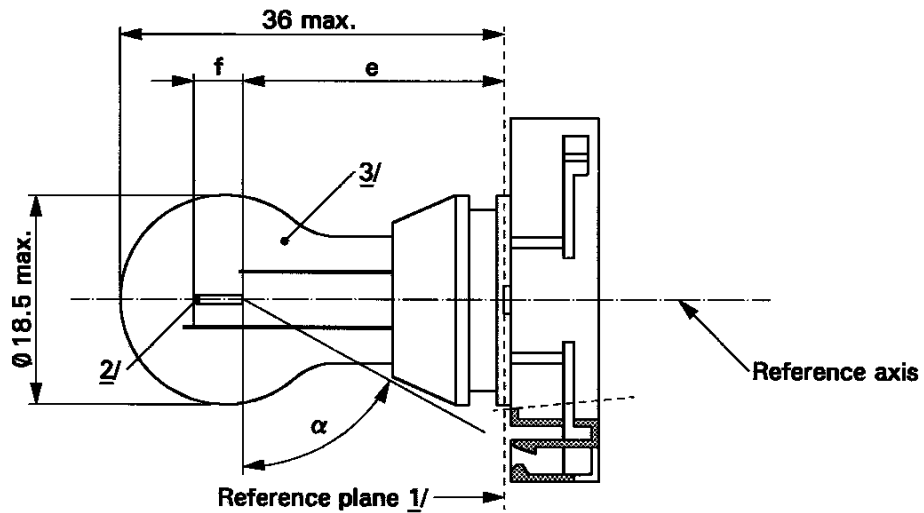

- 1/ The reference plane is defined by the meeting points of the cap-holder fit.
- 2/ No actual filament diameter restrictions apply but the objective is $d \text{ max.} = 1.1 \text{ mm}$.
- 3/ The light emitted from normal production lamps shall be white for categories P19W and PS19W; amber for categories PY19W and PSY19W; red for categories PR 19W and PSR 19W (see also note 8/).

CATEGORIES P19W, PY19W, PR19W, PS19W, PSY19W AND PSR19W

Sheet P19W/2

Dimensions in mm	<u>4/</u>	Filament lamps of normal production			Standard filament lamp
		min.	nom.	max.	<u>8/</u>
e	<u>5/</u> <u>6/</u>		24.0		24.0
f	<u>5/</u> <u>6/</u>		4.0		4.0 ± 0.2
α	<u>7/</u>	61.5°			61.5° min.
P19W Cap PGU20-1 PY19W Cap PGU20-2 PR19W Cap PGU20-5 PS19W Cap PG20-1 PSY19W Cap PG20-2 PSR19W Cap PG20-5		in accordance with IEC Publication 60061 (sheet 7004-127-2)			
ELECTRICAL AND PHOTOMETRIC CHARACTERISTICS					
Rated values	Volts	12			12
	Watts	19			19
Test voltage	Volts	13.5			13.5
Objective values	Watts	20 max.			20 max.
	Luminous flux	P19W PS19W	350 ± 15 %		
		PY19W PSY19W	215 ± 20 %		
		PR19W PSR19W	80 ± 20 %		
Reference luminous flux at approximately 13.5 V		White: 350 lm Amber: 215 lm Red: 80 lm			

- 4/ For categories PS19W, PSY19W and PSR19W, dimensions shall be checked with O-ring removed.
- 5/ The filament position is checked by means of a "Box-System"; sheet P19W/3.
- 6/ The ends of the filament are defined as the points where, when the viewing direction is perpendicular to the plane through the filament lead-in wires as showed in the drawing on sheet P19W/1, the projection of the outside of the end turns crosses the filament axis.
- 7/ No part of the cap beyond the reference plane shall interfere with angle α. The bulb shall be optically distortion free within the angle 2α + 180°.
- 8/ The light emitted from standard filament lamps shall be white for categories P19W and PS19W; white or amber for categories PY19W and PSY19W; white or red for categories PR19W and PSR19W.

CATEGORIES P19W, PY19W, PR19W, PS19W, PSY19W AND PSR19W

Sheet P19W/3

Screen projection requirements

This test is used to determine, by checking whether the filament is correctly positioned relative to the reference axis and reference plane, whether a filament lamp complies with the requirements.

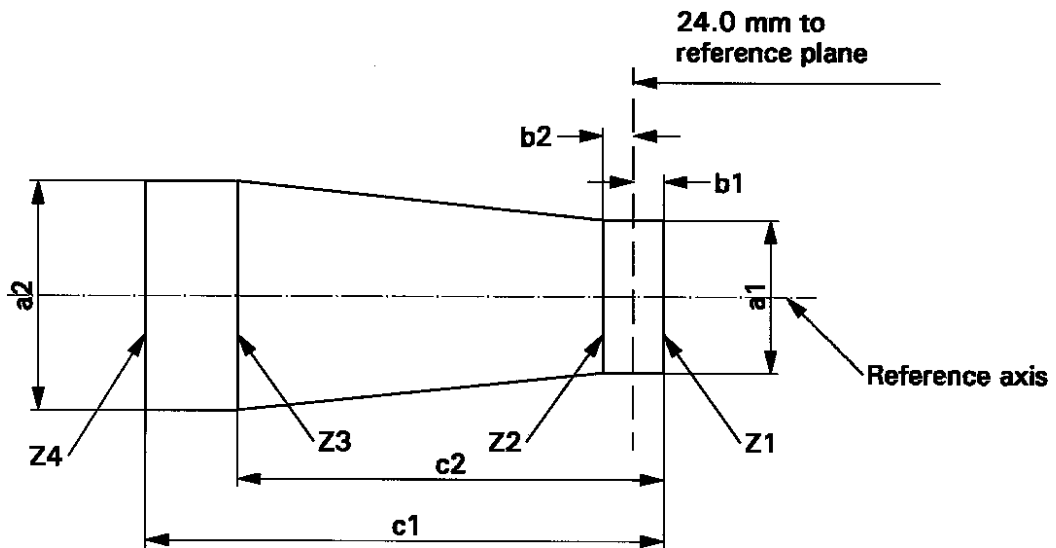

	a1	a2	b1, b2	c1	c2
Filament lamps of normal production	2.9	3.9	0.5	5.2	3.8
Standard filament lamps	1.5	1.7	0.25	4.7	3.8

The filament position is checked in two mutually perpendicular planes, one of them being the plane through the lead-in wires.

The ends of the filament as defined on sheet P19W/2, note 6/, shall lie between Z1 and Z2 and between the lines Z3 and Z4.

The filament shall lie entirely within the limits shown.

CATEGORY P21W

Sheet P21W/1

The drawings are intended only to illustrate the essential dimensions (in mm) of the filament lamp

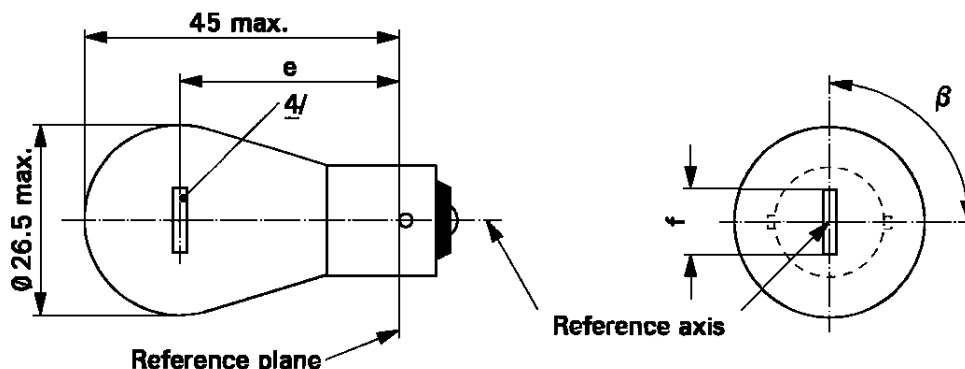

Dimensions in mm		Filament lamps of normal production			Standard filament lamp
		min.	nom.	max.	
e	6, 12 V		31.8 <u>3/</u>		31.8 ± 0.3
	24 V	30.8	31.8	32.8	
f	12 V	5.5	6.0	7.0	6.0 ± 0.5
	6 V			7.0	
Lateral deviation <u>1/</u>	6, 12 V			<u>3/</u>	0.3 max.
	24 V			1.5	
β		75°	90°	105°	90° ± 5°
Cap BA15s in accordance with IEC Publication 60061 (sheet 7004-11A-9) <u>2/</u>					
ELECTRICAL AND PHOTOMETRIC CHARACTERISTICS					
Rated values	Volts	6	12	24	12
	Watts	21			21
Test voltage	Volts	6.75	13.5	28.0	13.5
Objective values	Watts	27.6 max.	26.5 max.	29.7 max.	26.5 max.
	Luminous flux	460 ± 15 %			
Reference luminous flux: 460 lm at approximately 13.5 V					

- 1/ Maximum lateral deviation of filament centre from two mutually perpendicular planes both containing the reference axis and one containing the axis of the pins.
- 2/ Filament lamps with cap BA15d may be used for special purposes; they have the same dimensions.
- 3/ To be checked by means of a "Box-System"; sheet P21W/2.
- 4/ In this view the filament of the 24 V type may be straight or V-shaped. This shall be indicated in the application of approval. If it is straight, the screen projection requirements, sheet P21W/2, apply. If it is V-shaped, the filament ends shall be at the same distance within ± 3 mm from the reference plane.

Screen projection requirements

This test is used to determine, by checking whether the filament is correctly positioned relative to the reference axis and reference plane and has an axis perpendicular, within $\pm 15^\circ$, to the plane through the centre line of the pins (P21W) or of the reference pin (PY21W and PR21W) and the reference axis, whether a filament lamp complies with the requirements.

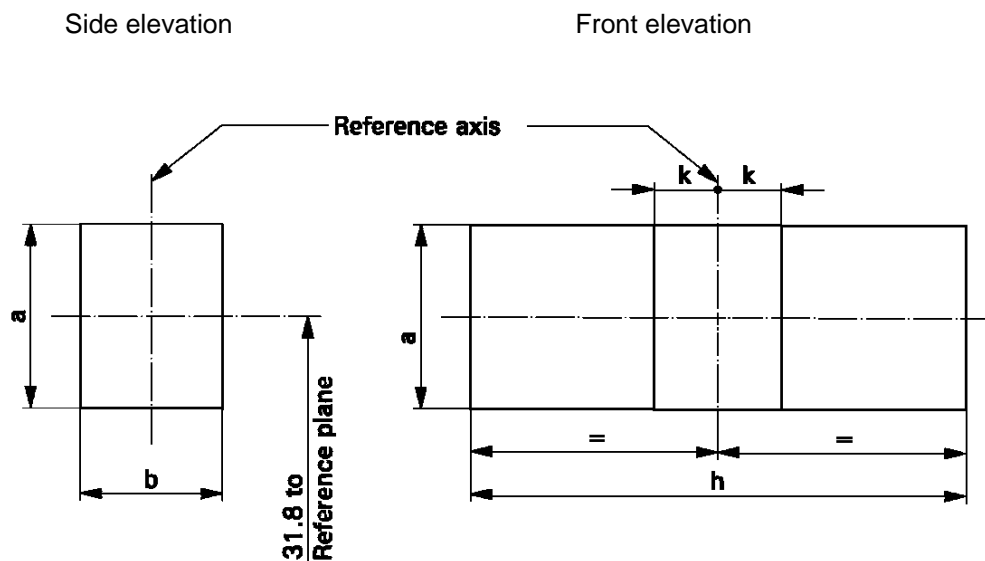

Reference	a	b	h	k
Dimension	3.5	3.0	9.0	1.0

Test procedures and requirements.

1. The filament lamp is placed in a holder capable of being rotated about its axis and having either a calibrated scale or fixed stops corresponding to the angular displacement tolerance limits. The holder is then so rotated that an end view of the filament is seen on the screen on to which the image of the filament is projected. The end view of the filament shall be obtained within the angular displacements tolerance limits.
2. Side elevation
 The filament lamp placed with the cap down, the reference axis vertical and the filament seen end-on, the projection of the filament shall lie entirely within a rectangle of height "a" and width "b", having its centre at the theoretical position of the centre of the filament.
3. Front elevation
 The filament lamp placed with the cap down and the reference axis vertical, the filament lamp being viewed in a direction at right angles to the filament axis:
 - 3.1. The projection of the filament shall lie entirely within a rectangle of height "a" and width "h", having its centre at the theoretical position of the centre of the filament.
 - 3.2. The centre of the filament shall not be offset by more than distance "k" from the reference axis.

CATEGORY P21/4W

Sheet P21/4W/1

The drawings are intended only to illustrate the essential dimensions (in mm) of the filament lamp

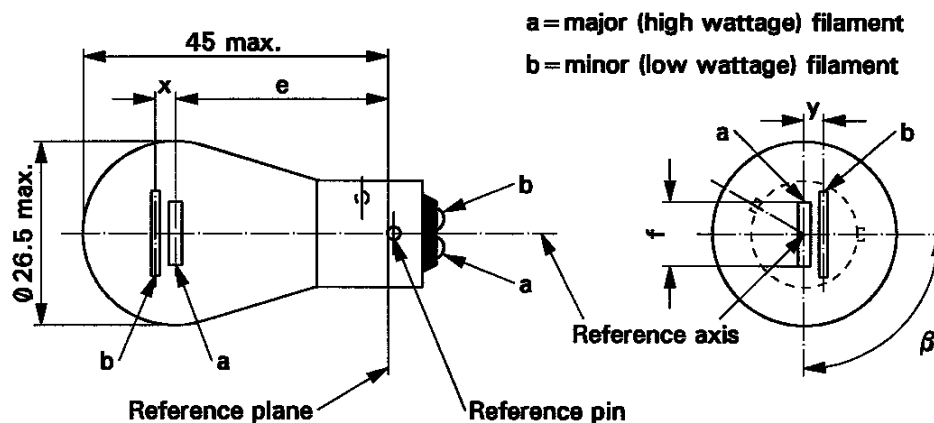

Dimensions in mm	Filament lamps of normal production			Standard filament lamp		
	min.	nom.	max.			
e		31.8 <u>1/</u>		31.8 ± 0.3		
f			7.0	7.0 + 0/- 2		
Lateral deviation			<u>1/</u>	0.3 max. <u>2/</u>		
x,y	<u>1/</u>			2.8 ± 0.5		
β	75° <u>1/</u>	90° <u>1/</u>	105° <u>1/</u>	90° ± 5°		
Cap BAZ15d in accordance with IEC Publication 60061 (sheet 7004-11C-3)						
ELECTRICAL AND PHOTOMETRIC CHARACTERISTICS						
Rated values	Volts	12		24		12
	Watts	21	4	21	4	21/4
Test voltage	Volts	13.5		28.0		13.5
Objective values	Watts	26.5 max.	5.5 max.	29.7 max.	8.8 max.	26.5/5.5 max.
	Luminous flux ± %	440	15	440	20	
		15	20	15	20	
Reference luminous flux: 440 lm and 15 lm at approximately 13.5 V						

- 1/ These dimensions shall be checked by means of a "Box-System" 3/ based on the dimensions and tolerances shown above. "x" and "y" refer to the major (high-wattage) filament, not to the reference axis. Means of increasing the positioning accuracy of the filament and of the cap-holder assembly are under consideration.
- 2/ Maximum lateral deviation of the major filament centre from two mutually perpendicular planes both containing the reference axis and one containing the axis of the reference pin.
- 3/ The "Box-System" is the same as for filament lamp P21/5W.

CATEGORY P21/5W

Sheet P21/5W/1

The drawings are intended only to illustrate the essential dimensions (in mm) of the filament lamp

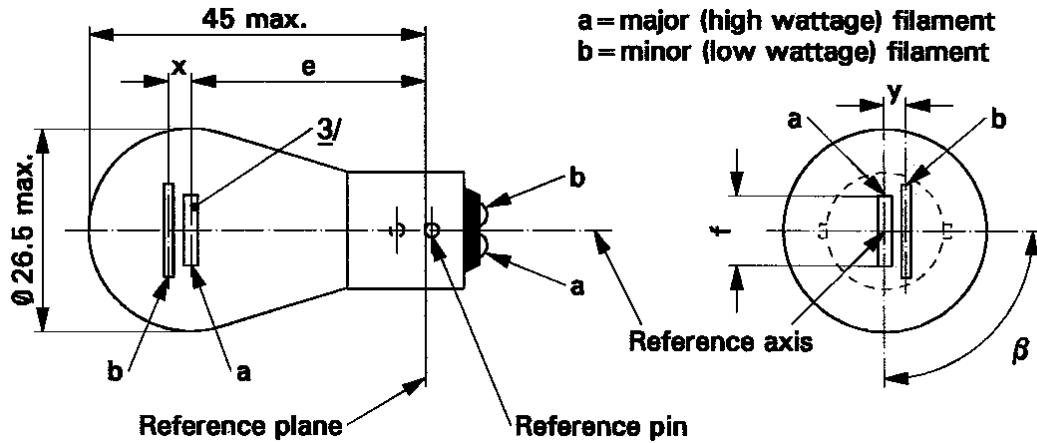

Dimensions in mm		Filament lamps of normal production			Standard filament lamp			
		min.	nom.	max.				
e	6, 12 V		31.8 <u>1/</u>		31.8 ± 0.3			
	24 V	30.8	31.8	32.8				
f	6, 12 V			7.0	7.0 + 0/- 2			
Lateral deviation <u>2/</u>	6, 12 V			<u>1/</u>	0.3 max.			
	24 V			1.5				
x, y	6, 12 V		<u>1/</u>		2.8 ± 0.3			
x	24 V <u>3/</u>	-1.0	0	1.0				
y	24 V <u>3/</u>	1.8	2.8	3.8				
β		75°	90°	105°	90° ± 5°			
Cap BAY15d in accordance with IEC Publication 60061 (sheet 7004-11B-7)								
ELECTRICAL AND PHOTOMETRIC CHARACTERISTICS								
Rated values	Volts	6		12		24		12
	Watts	21	5	21	5	21	5	21/5
Test voltage	Volts	6.75		13.5		28.0		13.5
Objective values	Watts	27.6 max.	6.6 max.	26.5 max.	6.6 max.	29.7 max.	11.0 max.	26.5 and 6.6 max.
	Luminous flux ± %	440	35	440	35	440	40	
		15	20	15	20	15	20	
Reference luminous flux: 440 and 35 lm at approximately 13.5 V								

For the notes see sheet P21/5W/2.

CATEGORY P21/5W

Sheet P21/5W/2

Notes

- 1/ These dimensions shall be checked by means of a "box-system". See sheets P21/5W/2 and P21/5W/3. "x" and "y" refer to the major (high-wattage) filament, not to the reference axis.
- 2/ Maximum lateral deviation of the major (high wattage) filament centre from two mutually perpendicular planes both containing the reference axis and one containing the axis of the reference pin.
- 3/ In this view the filaments of the 24 V type may be straight or V-shaped. This shall be indicated in the application of approval. If the filaments are straight, the screen projection requirements apply. If they are V-shaped, the ends of each filament shall be at the same distance within ± 3 mm from the reference plane.

Screen projection requirements

This test is used to determine, by checking whether:

- (a) the major (high wattage) filament is correctly positioned relative to the reference axis and reference plane and has an axis perpendicular, within $\pm 15^\circ$, to the plane through the centres of the pins and the reference axis; and whether
- (b) the minor (low wattage) filament is correctly positioned relative to the major (high wattage) filament, whether a filament lamp complies with the requirements.

Test procedure and requirements

1. The filament lamp is placed in a holder capable of being rotated about its axis and having either a calibrated scale or fixed stops corresponding to the angular displacement tolerance limits. (i.e. 15°). The holder is then so rotated that an end view of the major filament is seen on the screen on which the image of the filament is projected. The end view of that filament shall be obtained within the angular displacement tolerance limits.
2. Side elevation
The filament lamp placed with the cap down, the reference axis vertical, the reference pin to the right and the major filament seen end-on:
 - 2.1. the projection of the major filament shall lie entirely within a rectangle of height "a" and width "b", having its centre at the theoretical position of the centre of the filament;
 - 2.2. the projection of the minor filament shall lie entirely:
 - 2.2.1. within a rectangle of width "c" and height "d" having its centre at a distance "v" to the right of and at a distance "u" above the theoretical position of the centre of the major filament;
 - 2.2.2. above a straight line tangential to the upper edge of the projection of the major filament and rising from left to right at an angle of 25° .
 - 2.2.3. to the right of the projection of the major filament.
3. Front elevation
The filament lamp being placed with the cap down and the reference axis vertical, the filament lamp being viewed in a direction at right angles to axis of the major filament:
 - 3.1. the projection of the major filament shall lie entirely within a rectangle of height "a" and width "h", centred on the theoretical position of the centre of the filament;
 - 3.2. the centre of the major filament shall not be offset by more than distance "k" from the reference axis.
 - 3.3. the centre of the minor filament axis shall not be offset from the reference axis by more than ± 2 mm (± 0.4 mm for standard filament lamps).

Dimensions in mm

Side elevation

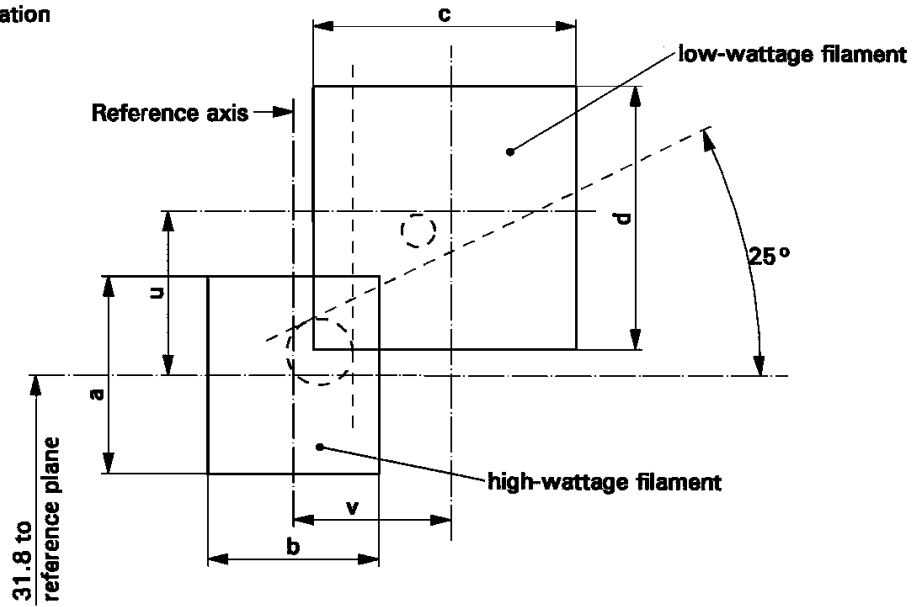

Reference	a	b	c	d	u	v
Dimensions	3.5	3.0	4.8			2.8

Front elevation

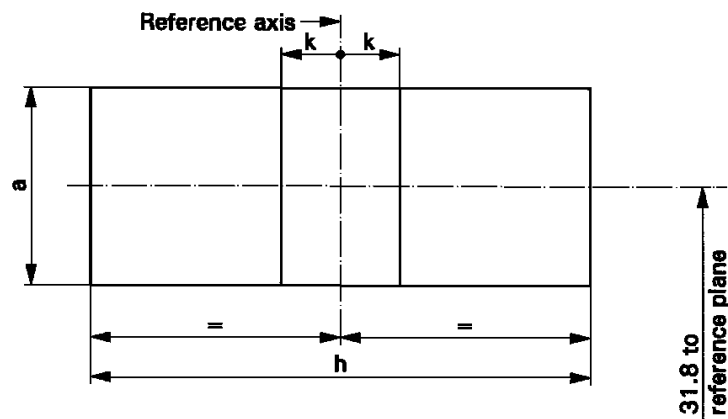

Reference	a	h	k
Dimensions	3.5	9.0	1.0

CATEGORIES P24W, PY24W, PR24W, PS24W, PSY24W AND PSR24W

Sheet P24W/1

The drawings are intended only to illustrate the essential dimensions (in mm) of the filament lamp

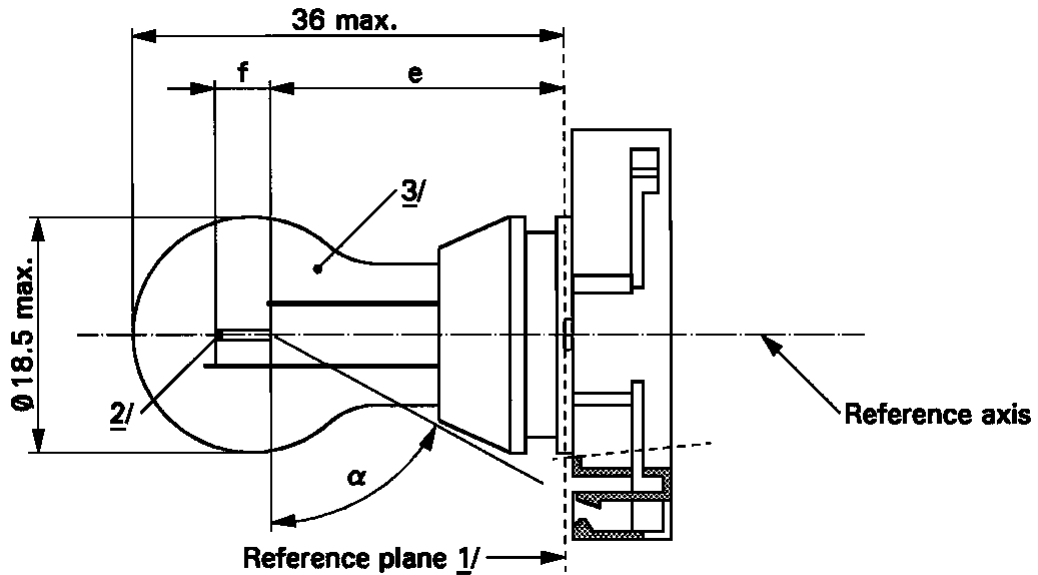

- 1/ The reference plane is defined by the meeting points of the cap-holder fit.
- 2/ No actual filament diameter restrictions apply but the objective is $d \text{ max.} = 1.1 \text{ mm}$.
- 3/ The light emitted from normal production lamps shall be white for categories P24W and PS24W; amber for categories PY24W and PSY24W; red for the categories PR24W and PSR24W (see also note 8/).

CATEGORIES P24W, PY24W, PR24W, PS24W, PSY24W AND PSR24W

Sheet P24W/2

Dimensions in mm	<u>4/</u>	Filament lamps of normal production			Standard filament lamp
		min.	nom.	max.	<u>8/</u>
e	<u>5/</u> <u>6/</u>		24.0		24.0
f	<u>5/</u> <u>6/</u>		4.0		4.0 ± 0.2
α	<u>7/</u>	61.5°			61.5° min.
P24W Cap PGU20-3 PY24W Cap PGU20-4 PR24W Cap PGU20-6 PS24W Cap PG20-3 PSY24W Cap PG20-4 PSR24W Cap PG20-6		in accordance with IEC Publication 60061 (sheet 7004-127-2)			
ELECTRICAL AND PHOTOMETRIC CHARACTERISTICS					
Rated values	Volts	12			12
	Watts	24			24
Test voltage	Volts	13.5			13.5
Objective values	Watts		25 max.		25 max.
	Luminous flux	P24W PS24W	500 +10/-20 %		
		PY24W PSY24W	300 +15/-25 %		
		PR24W PSR24W	115 +15/-25 %		
Reference luminous flux at approximately 13.5 V		White: 500 lm Amber: 300 lm Red: 115 lm			

- 4/ For categories PS24W, PSY24W and PSR24W, dimensions shall be checked with O-ring removed.
- 5/ The filament position is checked by means of a "Box-System"; sheet P24W/3.
- 6/ The ends of the filament are defined as the points where, when the viewing direction is perpendicular to the plane through the filament lead-in wires as showed in the drawing on sheet P24W/1, the projection of the outside of the end turns crosses the filament axis.
- 7/ No part of the cap beyond the reference plane shall interfere with angle α. The bulb shall be optically distortion free within the angle 2α + 180°.
- 8/ The light emitted from standard filament lamps shall be white for categories P24W and PS24W; white or amber for categories PY24W and PSY24W; white or red for categories PR24W and PSR24W.

CATEGORIES P24W, PY24W, PR24W, PS24W, PSY24W AND PSR24W

Sheet P24W/3

Screen projection requirements

This test is used to determine, by checking whether the filament is correctly positioned relative to the reference axis and reference plane, whether a filament lamp complies with the requirements.

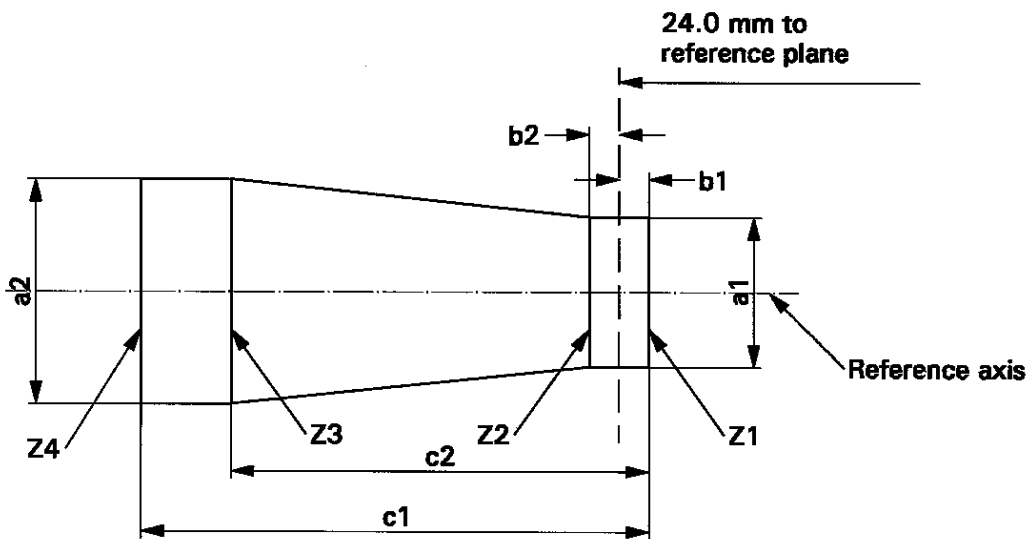

	a1	a2	b1, b2	c1	c2
Filament lamps of normal production	2.9	3.9	0.5	5.2	3.8
Standard filament lamps	1.5	1.7	0.25	4.7	3.8

The filament position is checked in two mutually perpendicular planes, one of them being the plane through the lead-in wires.

The ends of the filament as defined on sheet P24W/2, note 6/, shall lie between Z_1 and Z_2 and between the lines Z_3 and Z_4 .

The filament shall lie entirely within the limits shown.

CATEGORY P27W

Sheet P27W/1

The drawings are intended only to illustrate the essential dimensions (in mm) of the filament lamp

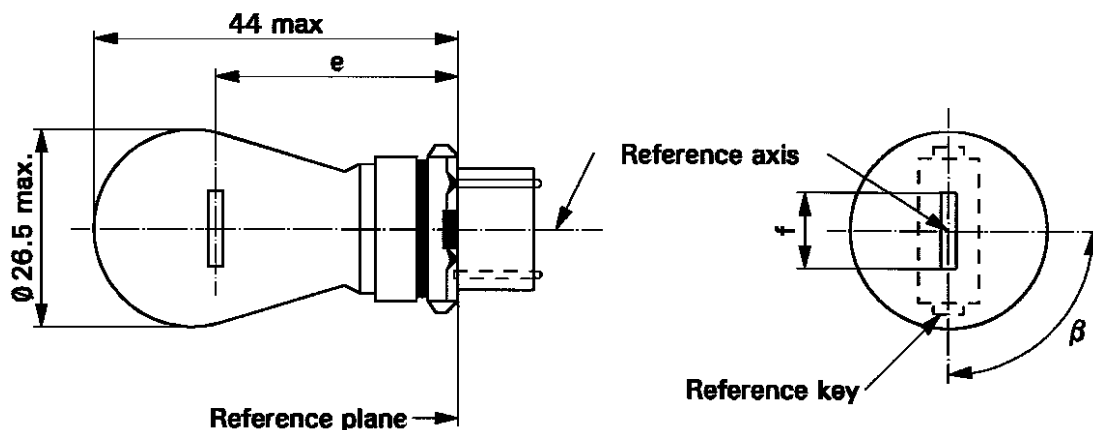

Dimensions in mm	Filament lamps of normal production			Standard filament lamp
	min.	nom.	max.	
e		27.9 <u>3/</u>		27.9 ± 0.3
f			9.9	9.9 + 0/ - 2
Lateral deviation <u>2/</u>			<u>3/</u>	0.0 ± 0.4
β	75° <u>3/</u>	90°	105° <u>3/</u>	90° ± 5°
Cap W2.5x16d in accordance with IEC Publication 60061 (sheet 7004-104-1)				
ELECTRICAL AND PHOTOMETRIC CHARACTERISTICS				
Rated values	Volts	12		12
	Watts	27		27
Test voltage	Volts	13.5		13.5
Objective values	Watts	32.1 max.		32.1 max.
	Luminous flux	475 ± 15 %		
Reference luminous flux: 475 lm at approximately 13.5 V				

- 1/ The reference axis is defined with respect to the reference keys and is perpendicular to the reference plane.
- 2/ Maximum lateral deviation of filament centre from two mutually perpendicular planes both containing the reference axis and one containing the axis through the reference keys.
- 3/ To be checked by means of a "Box System", sheet P27W/2.

CATEGORY P27W

Sheet P27W/2

Screen projection requirements

This test is used to determine, by checking whether the filament is correctly positioned relative to the reference axis and reference plane and has an axis perpendicular, within $\pm 15^\circ$, to the plane through the centres of the keys and the reference axis, whether a filament lamp complies with the requirements.

Side elevation

Front elevation

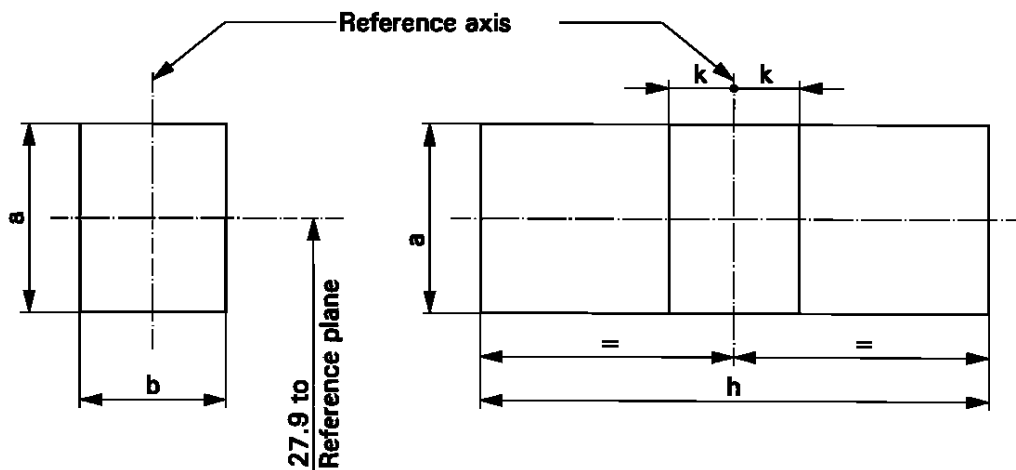

Reference	a	b	h	k
Dimension	3.5	3.0	11.9	1.0

Test procedures and requirements.

1. The filament lamp is placed in a holder capable of being rotated about its axis and having either a calibrated scale or fixed stops corresponding to the angular displacement tolerance limits. The holder is then so rotated that an end view of the filament is seen on the screen on to which the image of the filament is projected. The end view of the filament shall be obtained within the angular displacements tolerance limits.
2. Side elevation
 The filament lamp placed with the cap down, the reference axis vertical and the filament seen end-on, the projection of the filament shall lie entirely within a rectangle of height "a" and width "b", having its centre at the theoretical position of the centre of the filament.
3. Front elevation
 The filament lamp placed with the cap down and the reference axis vertical, the filament lamp being viewed in a direction at right angles to the filament axis:
 - 3.1. The projection of the filament shall lie entirely within a rectangle of height "a" and width "h", having its centre at the theoretical position of the centre of the filament.
 - 3.2. The centre of the filament shall not be offset by more than distance "k" from the reference axis.

CATEGORY P27/7W

Sheet P27/7W/1

The drawings are intended only to illustrate the essential dimensions (in mm) of the filament lamp

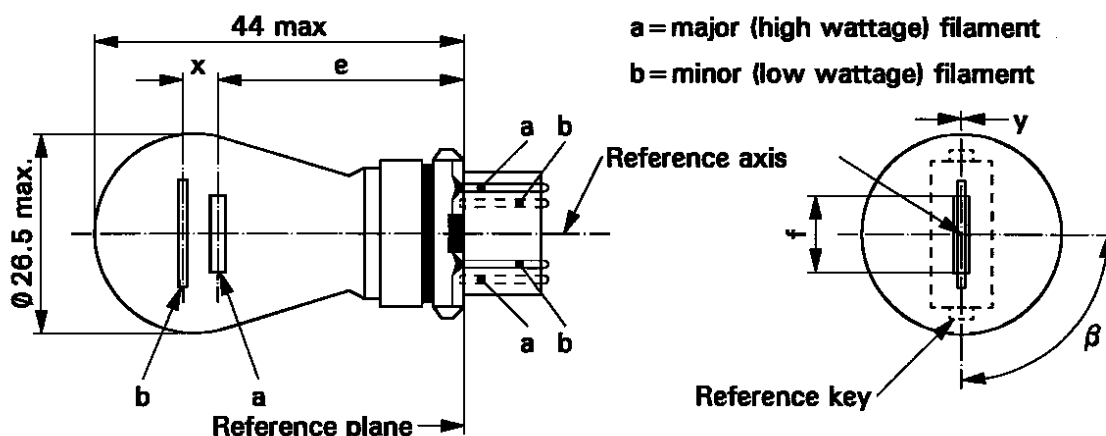

Dimensions in mm	Filament lamps of normal production			Standard filament lamp		
	min.	nom.	max.			
e		27.9 <u>3/</u>		27.9 ± 0.3		
f			9.9	9.9 + 0/ - 2		
Lateral deviation <u>2/</u>			<u>3/</u>	0.0 ± 0.4		
x <u>4/</u>		5.1 <u>3/</u>		5.1 ± 0.5		
y <u>4/</u>		0.0 <u>3/</u>		0.0 ± 0.5		
β	75° <u>3/</u>	90°	105° <u>3/</u>	90° ± 5°		
Cap W2.5x16q in accordance with IEC Publication 60061 (sheet 7004-104-1)						
ELECTRICAL AND PHOTOMETRIC CHARACTERISTICS						
Rated values	Volts	12			12	
	Watts	27		7	27	7
Test voltage	Volts	13.5			13.5	
Objective values	Watts	32.1 max.		8.5 max.	32.1 max.	8.5 max.
	Luminous flux	475 ± 15 %		36 ± 15 %		
Reference luminous flux: 475 and 36 lm at approximately 13.5 V						

- 1/ The reference axis is defined with respect to the reference keys and is perpendicular to the reference plane.
- 2/ Maximum lateral deviation of the major (high wattage) filament centre from two mutually perpendicular planes both containing the reference axis and one containing the axis through the reference keys.
- 3/ To be checked by means of a "Box-System", sheets P27/7W/2 and 3.
- 4/ "x" and "y" denote the offset of the axis of the minor (low wattage) filament with respect to the axis of the major (high wattage) filament.

CATEGORY P27/7W

Sheet P27/7W/2

Screen projection requirements

This test is used to determine, by checking whether:

- (a) the major (high wattage) filament is correctly positioned relative to the reference axis and reference plane and has an axis perpendicular, within $\pm 15^\circ$, to the plane through the centres of the keys and the reference axis; and whether:
- (b) the minor (low wattage) filament is correctly positioned relative to the major (high wattage) filament, whether a filament lamp complies with the requirements.

Test procedure and requirements.

1. The filament lamp is placed in a holder capable of being rotated about its axis and having either a calibrated scale or fixed stops corresponding to the angular displacement tolerance limits. The holder is then so rotated that an end view of the major filament is seen on the screen on which the image of the filament is projected. The end view of that filament shall be obtained within the angular displacement tolerance limits.
2. Side elevation
The filament lamp placed with the cap down, the reference axis vertical, the reference key to the right and the major filament seen end-on:
 - 2.1. the projection of the major filament shall lie entirely within a rectangle of height "a" and width "b", having its centre at the theoretical position of the centre of the filament;
 - 2.2. the projection of the minor filament shall lie entirely within a rectangle of width "c" and height "d" having its centre at a distance "u" above the theoretical position of the centre of the major filament.
3. Front elevation
The filament lamp being placed with the cap down and the reference axis vertical, the filament lamp being viewed in a direction at right angles to axis of the major filament:
 - 3.1. the projection of the major filament shall lie entirely within a rectangle of height "a" and width "h", centred on the theoretical position of the centre of the filament;
 - 3.2. the centre of the major filament shall not be offset by more than distance "k" from the reference axis;
 - 3.3. the centre of the minor filament axis shall not be offset from the reference axis by more than ± 2 mm (± 0.4 mm for standard filament lamps).

Side elevation

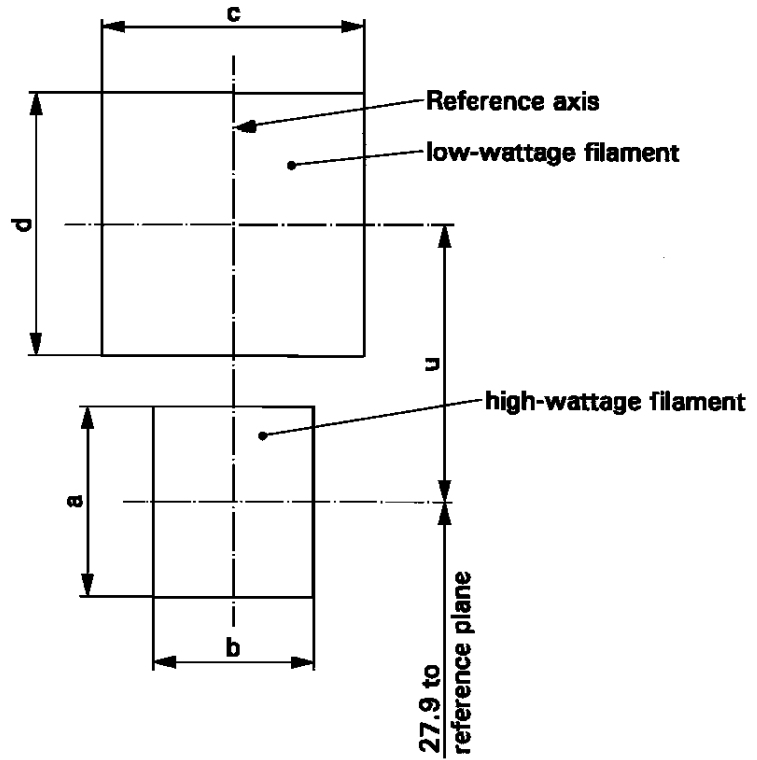

Reference	a	b	c	d	u
Dimensions	3.5	3.0	4.8		5.1

Front elevation

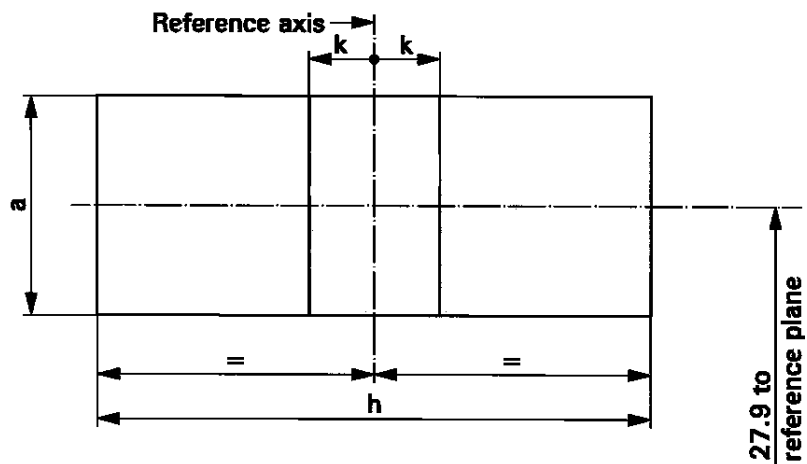

Reference	a	h	k
Dimensions	3.5	11.9	1.0

CATEGORY PR21W

Sheet PR21W/1

The drawings are intended only to illustrate the essential dimensions (in mm) of the filament lamp

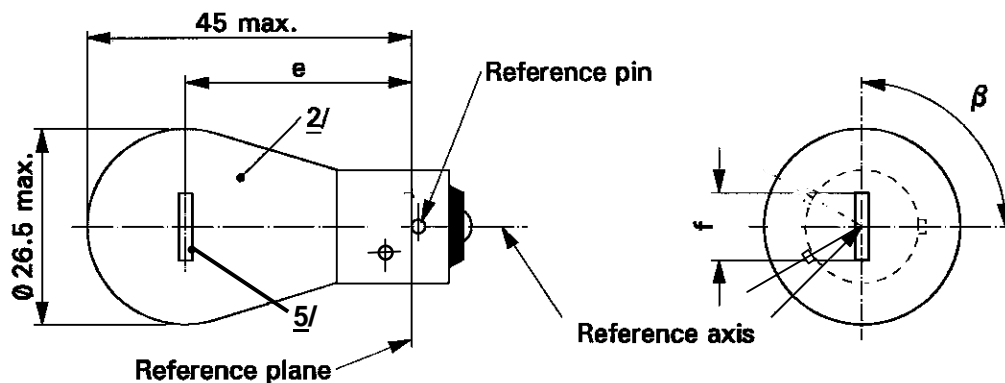

Dimensions in mm		Filament lamps of normal production			Standard filament lamp
		min.	nom.	max.	<u>4/</u>
e	12 V		31.8 <u>3/</u>		31.8 ± 0.3
	24 V	30.8	31.8	32.8	
f	12 V	5.5	6.0	7.0	6.0 ± 0.5
Lateral <u>1/</u> deviation	12 V			<u>3/</u>	0.3 max
	24 V			1.5	
β		75°	90°	105°	90° ± 5°
Cap BAW15s in accordance with IEC Publication 60061 (sheet 7004-11E-1)					
ELECTRICAL AND PHOTOMETRIC CHARACTERISTICS					
Rated values	Volts	12	24	12	
	Watts	21			21
Test voltage	Volts	13.5	28.0		
Objective values	Watts	26.5 max.	29.7 max.	26.5 max.	
	Luminous flux	110 ± 20 %			
Reference luminous flux at approximately 13.5 V:		White:	460 lm		
		Red:	110 lm		

- 1/ Maximum lateral deviation of filament centre from two mutually perpendicular planes both containing the reference axis and one containing the axis of the reference pin.
- 2/ The light emitted from normal production lamps shall be red (see also note 4/).
- 3/ To be checked by means of a "Box-System", sheet P21W/2.
- 4/ The light emitted from standard filament lamps shall be white or red.
- 5/ In this view the filament of the 24 V type may be straight or V-shaped. This shall be indicated in the application of approval. If it is straight, the screen projection requirements, sheet P21W/2, apply. If it is V-shaped, the filament ends shall be at the same distance within ± 3 mm from the reference plane.

CATEGORY PR21/4W

Sheet PR21/4W/1

The drawings are intended only to illustrate the essential dimensions (in mm) of the filament lamp

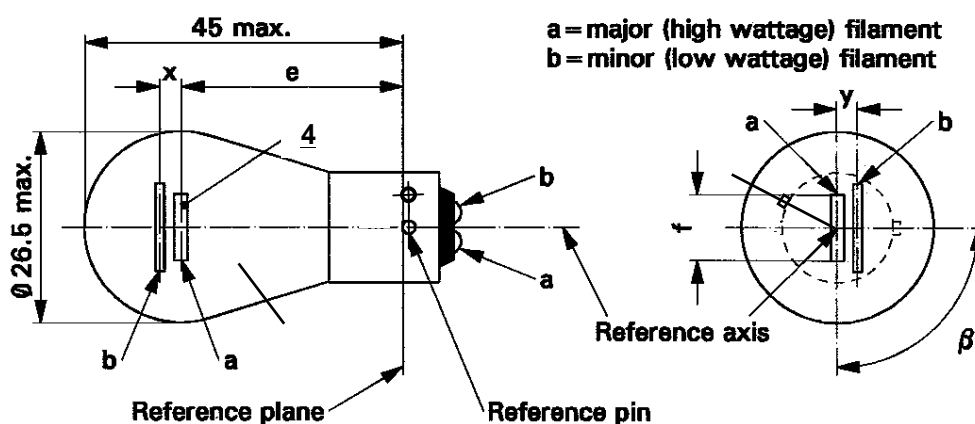

Dimensions in mm	Filament lamps of normal production <u>5/</u>			Standard filament lamp		
	min.	nom.	max.	<u>6/</u>		
e		31.8 <u>1/</u>		31.8 ± 0.3		
f			7.0	$7.0 + 0/- 2$		
Lateral deviation			<u>1/</u>	0.3 max. <u>2/</u>		
x,y	<u>1/</u>			2.8 ± 0.5		
β	75° <u>1/</u>	90° <u>1/</u>	105° <u>1/</u>	$90^\circ \pm 5^\circ$		
Cap BAU15d in accordance with IEC Publication 60061 (sheet 7004-19-2)						
ELECTRICAL AND PHOTOMETRIC CHARACTERISTICS						
Rated values	Volts	12		24 <u>4/</u>	12	
	Watts	21	4	21	4	21/4
Test voltage	Volts	13.5		28.0	13.5	
Objective values	Watts	26.5 max.	5.5 max.	29.7 max.	8.8 max.	26.5/5.5 max.
	Luminous flux $\pm \%$	105	4	105	5	
		20	25	20	25	
Reference luminous flux at approximately 13.5 V:	White: 440 lm and 15 lm Red : 105 lm and 4 lm					

- 1/ These dimensions shall be checked by means of a "Box-System" 3/ based on the dimensions and tolerances shown above. "x" and "y" refer to the major (high-wattage) filament, not to the reference axis. Means of increasing the positioning accuracy of the filament and of the cap-holder assembly are under consideration.
- 2/ Maximum lateral deviation of the major filament centre from two mutually perpendicular planes both containing the reference axis and one containing the axis of the reference pin.
- 3/ The "Box-System" is the same as for filament lamp P21/5W.
- 4/ The 24-Volt filament lamp is not recommended for future embodiments.
- 5/ The light emitted from normal production lamps shall be red (see also note 6/).
- 6/ The light emitted from standard filament lamps shall be white or red.

CATEGORY PR21/5W

Sheet PR21/5W/1

The drawings are intended only to illustrate the essential dimensions (in mm) of the filament lamp

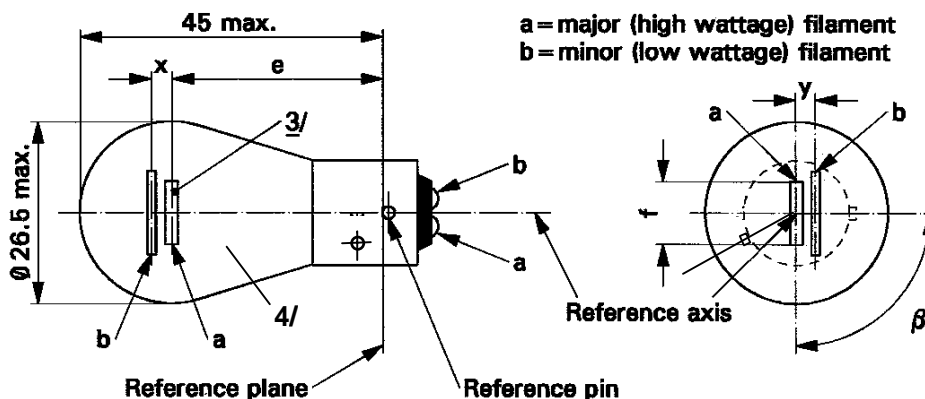

Dimensions in mm		Filament lamps of normal production <u>4/</u>			Standard filament lamp	
		min.	nom.	max.	<u>5/</u>	
e	12 V		31.8 <u>1/</u>		31.8 ± 0.3	
	24 V	30.8	31.8	32.8		
f	12 V			7.0	$7.0 + 0/- 2$	
Lateral deviation <u>2/</u>	12 V			<u>1/</u>	0.3 max.	
	24 V			1.5		
x, y	12 V		<u>1/</u>		2.8 ± 0.3	
x	24 V <u>3/</u>	-1.0	0	1.0		
y	24 V <u>3/</u>	1.8	2.8	3.8		
β		75°	90°	105°	$90^\circ \pm 5^\circ$	
Cap BAW15d in accordance with IEC Publication 60061 (sheet 7004-11E-1)						
ELECTRICAL AND PHOTOMETRIC CHARACTERISTICS						
Rated values	Volts	12		24		12
	Watts	21	5	21	5	21/5
Test voltage	Volts	13.5		28.0		13.5
Objective values	Watts	26.5 max.	6.6 max.	29.7 max.	11.0 max.	26.5 and 6.6 max.
	Luminous flux $\pm \%$	105	8	105	10	
		20	25	20	25	
Reference luminous flux at approximately 13.5 V:		White: 440 lm and 35 lm Red: 105 lm and 8 lm				

1/ See footnote 1/ on sheet P21/5W/2.

2/ See footnote 2/ on sheet P21/5W/2.

3/ See footnote 3/ on sheet P21/5W/2.

4/ The light emitted from normal production lamps shall be red (see also note 5/).

5/ The light emitted from standard filament lamps shall be white or red.

CATEGORY PR27/7W

Sheet PR27/7W/1

The drawings are intended only to illustrate the essential dimensions (in mm) of the filament lamp

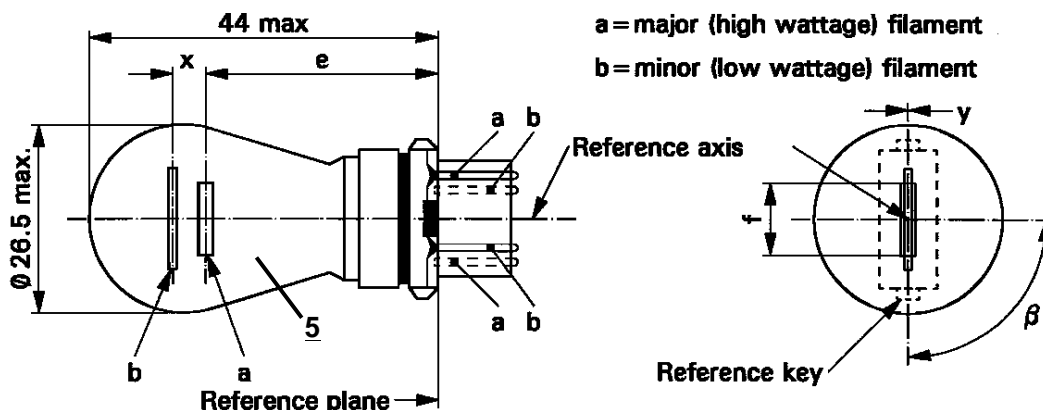

Dimensions in mm	Filament lamps of normal production			Standard filament lamp		
	min.	nom.	max.	<u>6/</u>		
e		27.9 <u>3/</u>		27.9 ± 0.3		
f			9.9	9.9 + 0/ - 2		
Lateral deviation <u>2/</u>			<u>3/</u>	0.0 ± 0.4		
x <u>4/</u>		5.1 <u>3/</u>		5.1 ± 0.5		
y <u>4/</u>		0.0 <u>3/</u>		0.0 ± 0.5		
β	75° <u>3/</u>	90°	105° <u>3/</u>	90° ± 5°		
Cap WU2.5x16 in accordance with IEC Publication 60061 (sheet 7004-104D-1)						
ELECTRICAL AND PHOTOMETRIC CHARACTERISTICS						
Rated values	Volts	12			12	
	Watts	27	7	27	7	
Test voltage	Volts	13.5			13.5	
Objective values	Watts	32.1 max.	8.5 max.	32.1 max.	8.5 max.	
	Luminous flux	110 ± 20 %	9 ± 20 %			
Reference luminous flux at approximately 13.5 V:	White: 475 and 36 lm Red: 110 and 9 lm					

- 1/ The reference axis is defined with respect to the reference keys and is perpendicular to the reference plane.
- 2/ Maximum lateral deviation of the major (high wattage) filament centre from two mutually perpendicular planes both containing the reference axis and one containing the axis through the reference keys.
- 3/ To be checked by means of a "Box-System", sheets P27/7W/2 and 3.
- 4/ "x" and "y" denote the offset of the axis of the minor (low wattage) filament with respect to the axis of the major (high wattage) filament.
- 5/ The light emitted from normal production lamps shall be red (see also note 6/).
- 6/ The light emitted from standard filament lamps shall be white or red.

CATEGORY PY21W

Sheet PY21W/1

The drawings are intended only to illustrate the essential dimensions (in mm) of the filament lamp

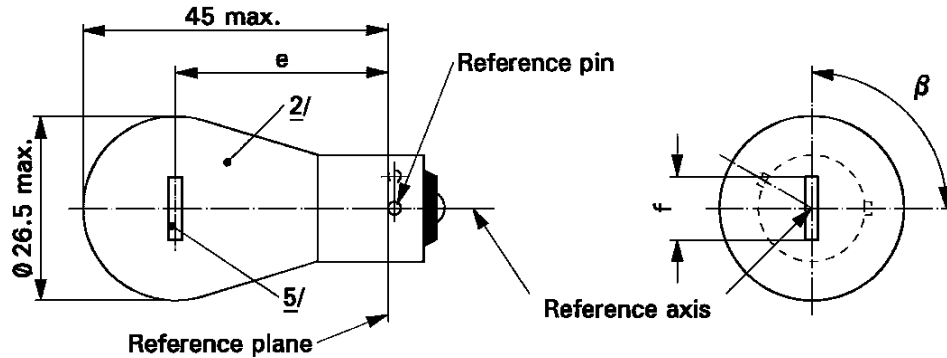

Dimensions in mm		Filament lamps of normal production			Standard filament lamp
		min.	nom.	max.	<u>4/</u>
e	12 V		31.8 <u>3/</u>		31.8 ± 0.3
	24 V	30.8	31.8	32.8	
f	12 V			7.0	7.0 +0/-2
Lateral deviation <u>1/</u>	12 V			<u>3/</u>	0.3 max.
	24 V			1.5	
β		75°	90°	105°	90° ± 5°
Cap BAU15s in accordance with IEC Publication 60061 (sheet 7004-19-2)					
ELECTRICAL AND PHOTOMETRIC CHARACTERISTICS					
Rated values	Volts	12	24		12
	Watts	21			21
Test voltage	Volts	13.5	28.0		13.5
Objective values	Watts	26.5 max.	29.7 max.		26.5 max.
	Luminous flux	280 ± 20 %			
Reference luminous flux at approximately 13.5 V:		White: 460 lm			
		Amber: 280 lm			

- 1/ Maximum lateral deviation of filament centre from two mutually perpendicular planes both containing the reference axis and one containing the axis of the reference pin.
- 2/ The light emitted from production lamps shall be amber (see also note 4/).
- 3/ To be checked by means of a "Box-System"; sheet P21W/2.
- 4/ The light emitted from standard filament lamps shall be amber or white.
- 5/ In this view the filament of the 24 V type may be straight or V-shaped. This shall be indicated in the application of approval. If it is straight, the screen projection requirements, sheet P21W/2, apply. If it is V-shaped, the filament ends shall be at the same distance within ± 3 mm from the reference plane.

CATEGORY PY27/7W

Sheet PY27/7W/1

The drawings are intended only to illustrate the essential dimensions (in mm) of the filament lamp

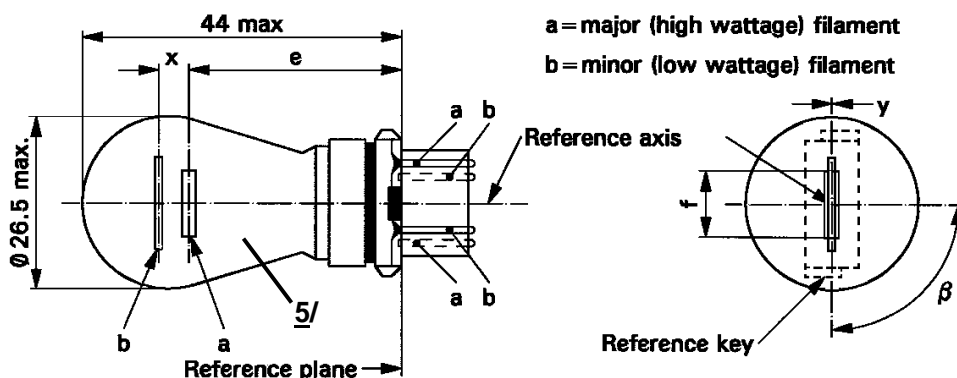

Dimensions in mm	Filament lamps of normal production			Standard filament lamp		
	min.	nom.	max.	<u>6/</u>		
e		27.9 <u>3/</u>		27.9 ± 0.3		
f			9.9	9.9 + 0/ - 2		
Lateral deviation <u>2/</u>			<u>3/</u>	0.0 ± 0.4		
x <u>4/</u>		5.1 <u>3/</u>		5.1 ± 0.5		
y <u>4/</u>		0.0 <u>3/</u>		0.0 ± 0.5		
β	75° <u>3/</u>	90°	105° <u>3/</u>	90° ± 5°		
Cap WX2.5x16q in accordance with IEC Publication 60061 (sheet 7004-104A-1)						
ELECTRICAL AND PHOTOMETRIC CHARACTERISTICS						
Rated values	Volts	12			12	
	Watts	27	7	27	7	
Test voltage	Volts	13.5			13.5	
Objective values	Watts	32.1 max.	8.5 max.	32.1 max.	8.5 max.	
	Luminous flux	280 ± 15 %	21 ± 15 %			
Reference luminous flux at approximately 13.5 V:	White: 475 and 36 lm Amber: 280 and 21 lm					

- 1/ The reference axis is defined with respect to the reference keys and is perpendicular to the reference plane.
- 2/ Maximum lateral deviation of the major (high wattage) filament centre from two mutually perpendicular planes both containing the reference axis and one containing the axis through the reference keys.
- 3/ To be checked by means of a "Box-System", sheets P27/7W/2 and 3.
- 4/ "x" and "y" denote the offset of the axis of the minor (low wattage) filament with respect to the axis of the major (high wattage) filament.
- 5/ The light emitted from filament lamps of normal production shall be amber (see also note 6/).
- 6/ The light emitted from standard filament lamps shall be amber or white.

CATEGORY R2

Sheet R2/1

The drawings are intended only to illustrate the essential dimensions (in mm) of the filament lamp

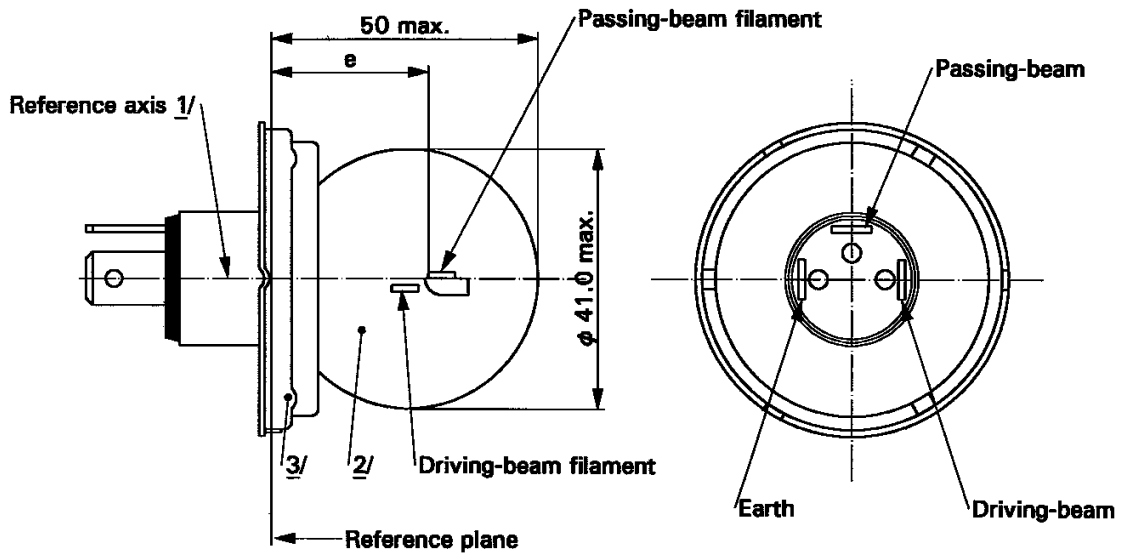

ELECTRICAL AND PHOTOMETRIC CHARACTERISTICS									
		Filament lamps of normal production						Standard filament lamp	
Rated values	Volts	6 ^{4/}		12 ^{4/}		24 ^{4/}		12 ^{4/}	
	Watts	45	40	45	40	55	50	45	40
Test voltage	Volts	6.3		13.2		28.0		13.2	
Objective values	Watts	53 max.	47 max.	57 max.	51 max.	76 max.	69 max.	52 +0 % -10 %	46 ± 5 %
	Luminous flux	720 min.	570 ±15%	860 min.	675 ±15%	1000 min.	860 ±15%		
Measuring flux	^{5/}	-	450	-	450	-	450		
Reference luminous flux at approximately 12V								700	450

- 1/ The reference axis is perpendicular to the reference plane and passes through the centre of the 45 mm cap diameter.
- 2/ The bulb shall be colourless or selective-yellow.
- 3/ No part of the cap shall, by reflection of light emitted by the passing-beam filament, throw any stray rising ray when the filament lamp is in the normal operating position on the vehicle.
- 4/ The values indicated on the left and on the right refer to the driving-beam filament and the passing-beam filament respectively.
- 5/ Measuring luminous flux for measurements according to paragraph 3.9. of this Regulation.

Note: The R2 filament lamp is not recommended for new headlamp designs.

CATEGORY R2

Sheet R2/2

Position and dimensions (in mm) of shield and filaments

The drawings are not mandatory with respect to the design of the shield and filaments

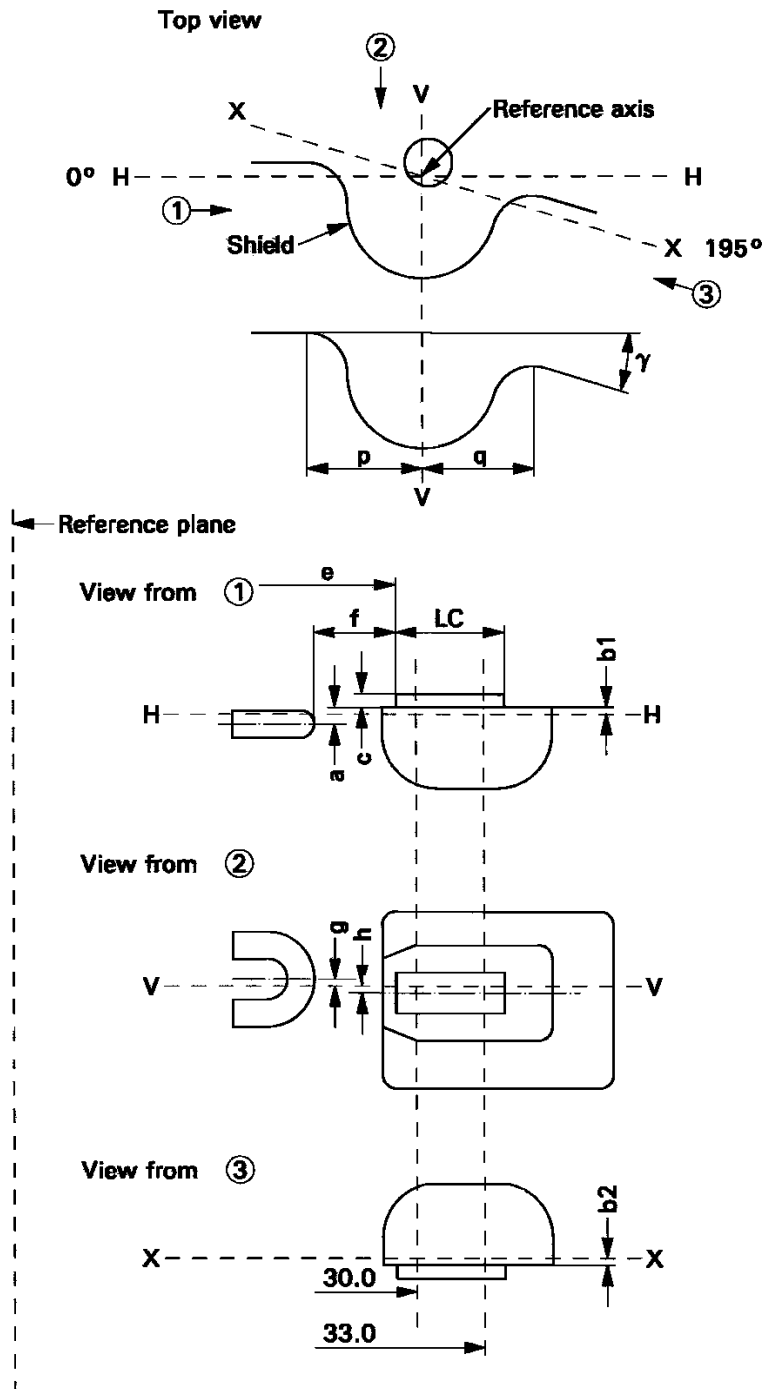

CATEGORY R2

Sheet R2/3

FILAMENTS AND SHIELD POSITION AND DIMENSIONS				1/	
Dimensions in mm		Tolerance			
		Filament lamps of normal production			Standard filament lamp
		6V	12V	24V	12V
a		0.60		± 0.35	± 0.15
b1/30.0	<u>2/</u>	0.20		± 0.35	± 0.15
b1/33.0		b1/30.0 mv	<u>3/</u>		
b2/30.0	<u>2/</u>	0.20		± 0.35	± 0.15
b2/33.0		b2/30.0 mv	<u>3/</u>		
c/30.0	<u>2/</u>	0.50		± 0,30	± 0.15
c/33.0		c/30.0 mv	<u>3/</u>		
e	6, 12 V 24V	28.5 28.8		± 0.35	± 0.15
f	6, 12 V 24 V	1.8 2.2		± 0.40	± 0.20
g		0		± 0.50	± 0.30
h/30.0	<u>2/</u>	0		± 0.50	± 0.30
h/33.0		h/30.0 mv	<u>3/</u>		
1/2(p-q)		0		± 0.60	± 0.30
lc		5.5		± 1.50	± 0.50
γ	<u>4/</u>	15° nom.			
Cap P45t-41 in accordance with IEC Publication 60061 (sheet 7004-95-5)					

- 1/ The position and dimensions of the shield and filaments shall be checked by means of the method of measurement as described in IEC Publication 60809.
- 2/ To be measured at the distance from the reference plane indicated in millimetres behind the stroke.
- 3/ mv = measured value.
- 4/ The angle γ is only for shield design and has not to be checked on finished filament lamps.

CATEGORY R5W and RR5W

Sheet R5W/1

The drawings are intended only to illustrate the essential dimensions (in mm) of the filament lamp

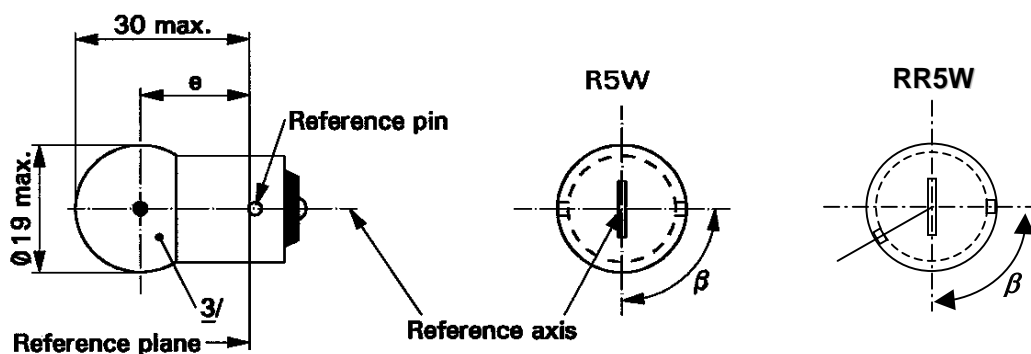

Dimensions in mm	Filament lamps of normal production			Standard filament lamp	
	min.	nom.	max.	<u>4/</u>	
e	17.5	19.0	20.5	19.0 ± 0.3	
Lateral deviation <u>2/</u>			1.5	0.3 max.	
β	60°	90°	120°	90° ± 5°	
Cap: R5W: BA15s RR5W: BAW15s	in accordance with IEC Publication 60061			(sheet 7004-11A-9) <u>1/</u> (sheet 7004-11E-1)	
ELECTRICAL AND PHOTOMETRIC CHARACTERISTICS					
Rated values	Volts	6 <u>5/</u>	12	24	12
	Watts	5			5
Test voltage	Volts	6.75	13.5	28.0	13.5
Objective values	Watts	5.5 max.		7.7 max.	5.5 max.
	Luminous flux	R5W	50 ± 20 %		
		RR5W	<u>5/</u>	12 ± 25 %	
Reference luminous flux at approximately 13.5 V:		White:	50 lm		
		Red:	2 lm		

- 1/ Filament lamps with cap BA15d may be used for special purposes; they have the same dimensions.
- 2/ Maximum lateral deviation of filament centre from two mutually perpendicular planes both containing the reference axis and one containing the axis of the reference pin.
- 3/ The light emitted from filament lamps of normal production shall be white for category R5W and red for category RR5W (see also note 4/).
- 4/ The light emitted from standard filament lamps shall be white for category R5W; white or red for category RR5W.
- 5/ Within RR5W no 6 V rated voltage type specified.

CATEGORIES R10W, RY10W AND RR10W

Sheet R10W/1

The drawings are intended only to illustrate the essential dimensions (in mm) of the filament lamp.

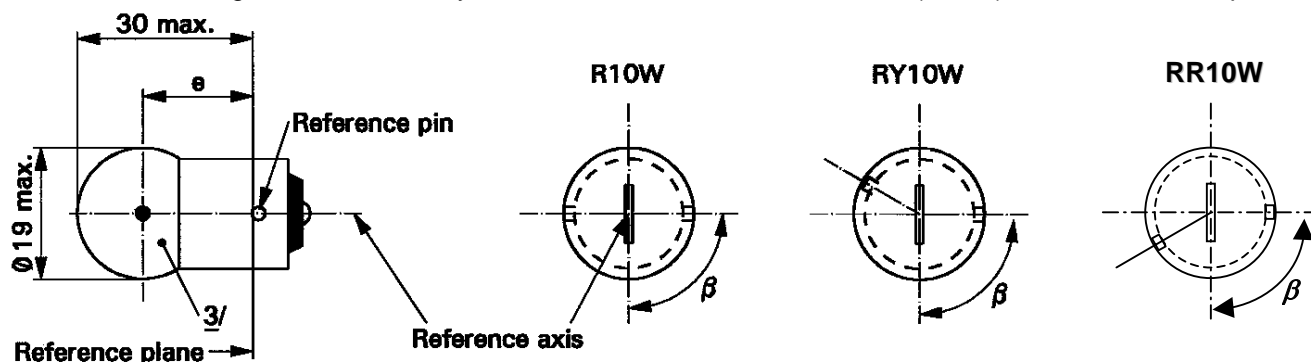

Dimensions in mm		Filament lamps of normal production			Standard filament lamp	
		min.	nom.	max.	4/	
e		17.5	19.0	20.5	19.0 ± 0.3	
Lateral deviation	2/			1.5	0.3 max.	
β		60°	90°	120°	90° ± 5°	
R10W: BA15s Cap: RY10W: BAU15s in accordance with IEC Publication 60061 RR10W: BAW15s					(sheet 7004-11A-9) 1/ (sheet 7004-19-2) (sheet 7004-11E-1)	
ELECTRICAL AND PHOTOMETRIC CHARACTERISTICS						
Rated values		Volts	6 5/	12	24	12
		Watts	10			10
Test voltage		Volts	6.75	13.5	28	13.5
Objective values	Watts	R10W RY10W	11 max.		14 max.	11 max.
		RR10W	5/	11 max.		11 max.
	Luminous flux	R10W	125 ± 20 %			
		RY10W	75 ± 20 %			
		RR10W	5/	30 ± 25 %		
Reference luminous flux at approximately 13.5 V:		White: 125 lm Amber: 75 lm Red: 30 lm				

- 1/ Filament lamps R10W with cap BA15d may be used for special purposes; they have the same dimensions.
- 2/ Maximum lateral deviation of filament centre from two mutually perpendicular planes both containing the reference axis and one containing the axis of the reference pin.
- 3/ The light emitted from filament lamps of normal production shall be white for category R10W, amber for category RY10W and red for category RR10W (see also note 4/.)
- 4/ The light emitted from standard filament lamps shall be white for category R10W; white or amber for category RY10W; white or red for category RR10W.
- 5/ Within RR10W no 6 V rated voltage type specified.

CATEGORIES S1 AND S2

Sheet S1/S2/1

The drawings are intended only to illustrate the essential dimensions (in mm) of the filament lamp.

FILAMENT LAMPS FOR MOTORCYCLES

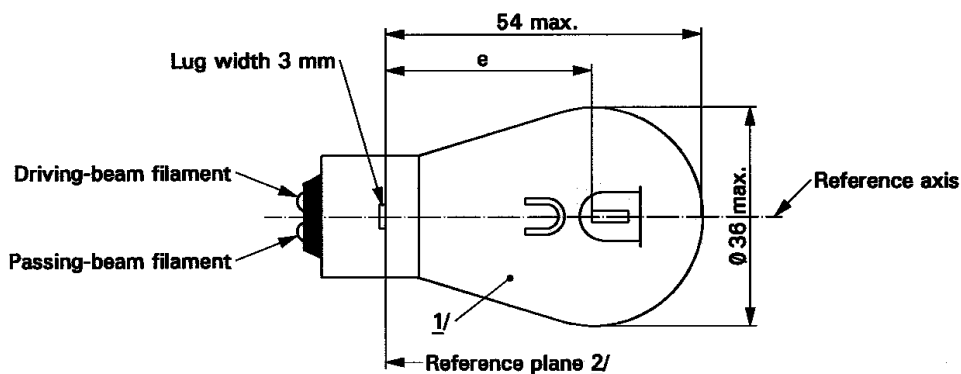

Position and dimensions of filaments

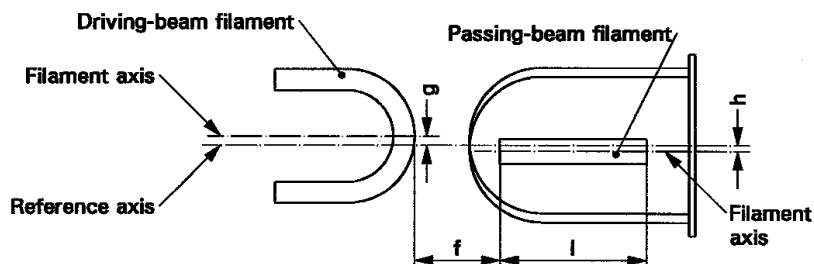

Position of shield 3/ 4/

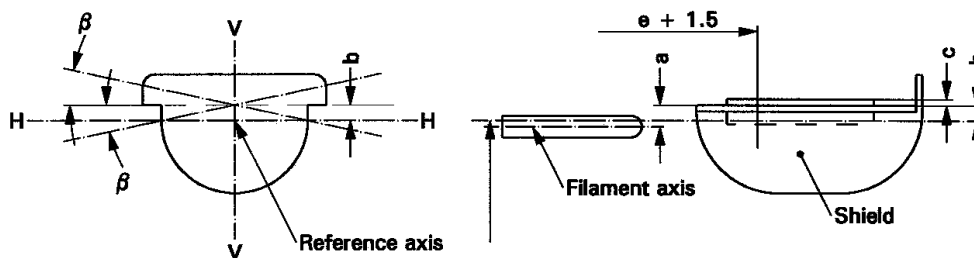

- 1/ The bulb shall be colourless or selective-yellow.
- 2/ The reference plane is perpendicular to the reference axis and touches the upper surface of the lug having a width of 4.5 mm.
- 3/ Plane V-V contains the reference axis and the centre line of the lugs.
- 4/ Plane H-H (the normal position of the shield) is perpendicular to plane V-V and contains the reference axis.

CATEGORIES S1 AND S2

Sheet S1/S2/2

Dimensions in mm		Filament lamps of normal production			Standard filament lamp			
		min.	nom.	max.				
e		32.35	32.70	33.05	32.7 ± 0.15			
f		1.4	1.8	2.2	1.8 ± 0.2			
l		4.0	5.5	7.0	5.5 ± 0.5			
c	<u>5/</u>	0.2	0.5	0.8	0.5 ± 0.15			
b	<u>5/</u>	- 0.15	0.2	0.55	0.2 ± 0.15			
a	<u>5/</u>	0.25	0.6	0.95	0.6 ± 0.15			
h		- 0.5	0	0.5	0 ± 0.2			
g		- 0.5	0	0.5	0 ± 0.2			
β	<u>5/ 6/</u>	- 2°30'	0°	+2°30'	0° ± 1°			
Cap BA20d in accordance with IEC Publication 60061 (sheet 7004-12-7)								
ELECTRICAL AND PHOTOMETRIC CHARACTERISTICS								
Rated values	Volts	S1	6 <u>7/</u>		12 <u>7/</u>		6	
		S2					12	
	Watts	S1	25	25	25	25	25	25
		S2	35	35	35	35	35	35
Test voltage	Volts	S1	6.75		13.5		6.75	
		S2	6.3		13.5		13.5	
Objective values	Watts	S1	25 ± 5%	25 ± 5%	25 ± 5%	25 ± 5%	25 ± 5%	25 ± 5%
		S2	35 ± 5%	35 ± 5%	35 ± 5%	35 ± 5%	35 ± 5%	35 ± 5%
	Luminous flux	S1	435±20%	315±20%	435±20%	315±20%		
		S2	650±20%	465±20%	650±20%	465±20%		
Reference luminous flux:		S1: 398 and 284 lm at approximately 6 V						
		S2: 568 and 426 lm at approximately 12 V						

- 5/ Dimensions a, b, c and β refer to a plane parallel to the reference plane and cutting the two edges of the shield at a distance of e + 1.5 mm.
- 6/ Admissible angular deviation of the shield plane position from the normal position.
- 7/ Values in the left-hand column refer to the driving-beam filament. Values in the right-hand column to the passing-beam filament.

CATEGORY S3

Sheet S3/1

The drawings are intended only to illustrate the essential dimensions (in mm) of the filament lamp

FILAMENT LAMP FOR MOPEDS

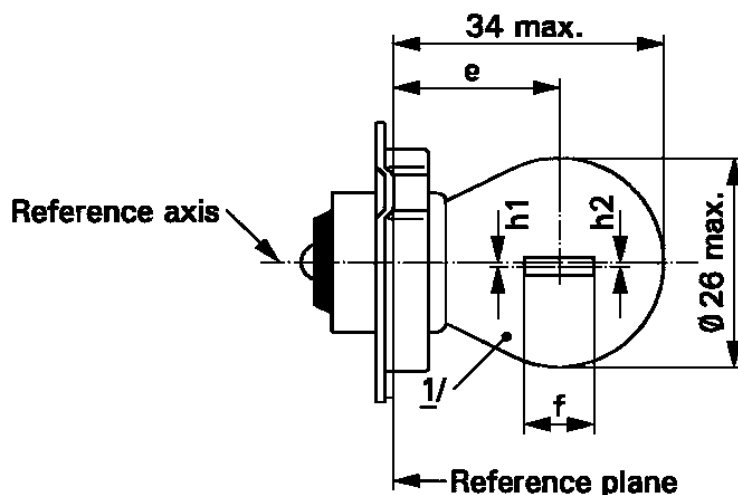

Dimensions in mm		Filament lamps of normal production			Standard filament lamp
		min.	nom.	max.	
e	<u>2/</u>	19.0	19.5	20.0	19.5 ± 0.25
f	6 V			3.0	2.5 ± 0.5
	12 V			4.0	
h1, h2	<u>3/</u>	- 0.5	0	0.5	0 ± 0.3
Cap P26s in accordance with IEC Publication 60061 (sheet 7004-36-1)					
ELECTRICAL AND PHOTOMETRIC CHARACTERISTICS					
Rated values	Volts	6	12	6	
	Watts	15			15
Test voltage	Volts	6.75	13.5	6.75	
Objective values	Watts	15 ± 6%			15 ± 6%
	Luminous flux	240 ± 15%			
Reference luminous flux: 240 lm at approximately 6.75 V					

- 1/ The bulb shall be colourless or selective-yellow.
- 2/ Distance related to the luminous centre.
- 3/ Lateral deviation of filament axis with respect to the reference axis. It is sufficient to check this deviation in two mutually perpendicular planes.

CATEGORY T1.4W

Sheet T1.4W/1

The drawings are intended only to illustrate the essential dimensions (in mm) of the filament lamp.

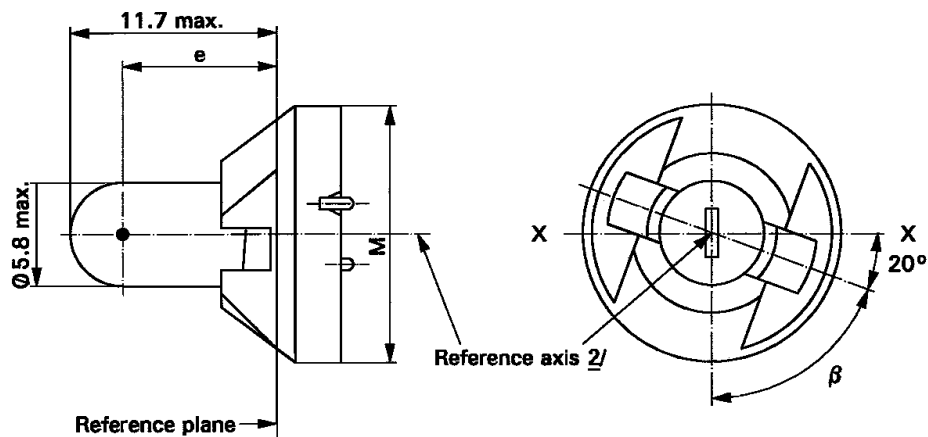

Dimensions in mm	Filament lamps of normal production			Standard filament lamp
	min.	nom.	max.	
e	7.6	8.3	9.0	8.3 ± 0.35
Lateral deviation <u>1/</u>			0.7	0.35 max
β	55°	70°	85°	$70^\circ \pm 5^\circ$
Cap P11.5d in accordance with IEC Publication 60061 (sheet 7004-79-1)				
ELECTRICAL AND PHOTOMETRIC CHARACTERISTICS				
Rated values	Volts	12		12
	Watts	1.4		1.4
Test voltage	Volts	13.5		13.5
Objective values	Watts	1.54 max.		1.54 max.
	Luminous flux	$8 \pm 15 \%$		
Reference luminous flux: 8 lm at approximately 13.5 V				

1/ Maximum lateral deviation of filament centre from two mutually perpendicular planes both containing the reference axis and one containing axis X-X.

2/ The reference axis is perpendicular to the reference plane and passes through the centre of the circle of diameter "M".

CATEGORY T4W

Sheet T4W/1

The drawings are intended only to illustrate the essential dimensions (in mm) of the filament lamp.

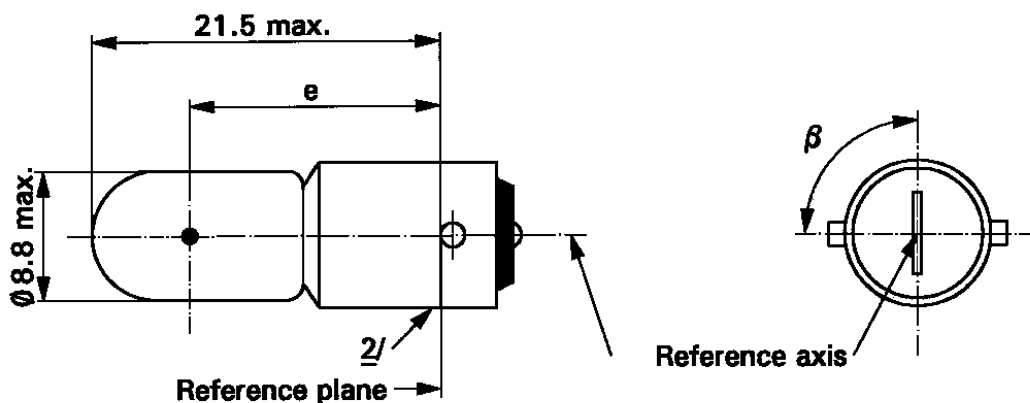

Dimensions in mm	Filament lamps of normal production			Standard filament lamp	
	min.	nom.	max.		
e	13.5	15.0	16.5	15.0 ± 0.3	
Lateral deviation ^{1/}			1.5	0.5 max	
β		90°		$90^\circ \pm 5^\circ$	
Cap BA9s in accordance with IEC Publication 60061 (sheet 7004-14-8)					
ELECTRICAL AND PHOTOMETRIC CHARACTERISTICS					
Rated values	Volts	6	12	24	12
	Watts	4			4
Test voltage	Volts	6.75	13.5	28.0	13.5
Objective values	Watts	4.4 max.		5.5 max.	4.4 max.
	Luminous flux	35 \pm 20 %			
Reference luminous flux: 35 lm at approximately 13.5 V					

- ^{1/} Maximum lateral deviation of filament centre from two mutually perpendicular planes both containing the reference axis and one containing the axis of pins.
- ^{2/} Over the entire length of the cap there shall be no projections or soldering extending beyond the permissible maximum diameter of the cap.

CATEGORY W2.3W

Sheet W2.3W/1

The drawings are intended only to illustrate the essential dimensions (in mm) of the filament lamp

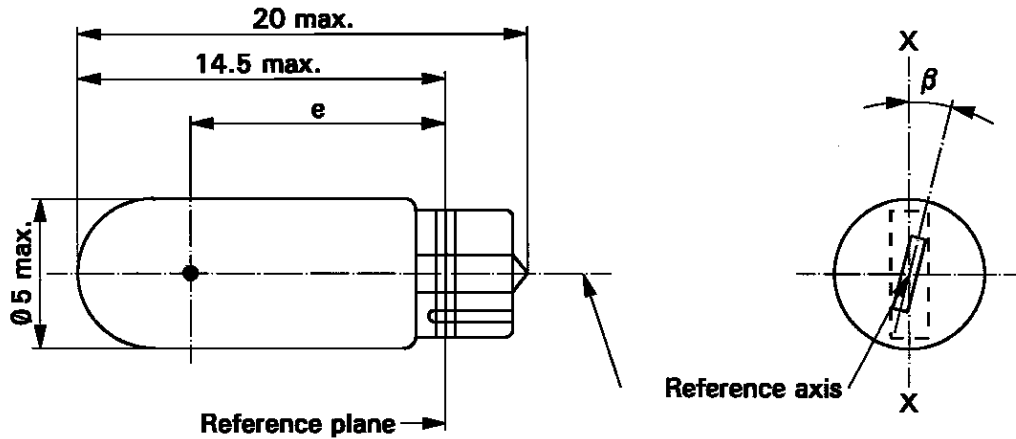

Dimensions in mm	Filament lamps of normal production			Standard filament lamp
	min.	nom.	max.	
e	10.3	10.8	11.3	10.8 ± 0.3
Lateral deviation ^{1/}			1.0	0.5 max
β	- 15°	0°	+ 15°	0° ± 5°
Cap W2x4.6d in accordance with IEC Publication 60061 (sheet 7004-94-2)				
ELECTRICAL AND PHOTOMETRIC CHARACTERISTICS				
Rated values	Volts	12		12
	Watts	2.3		2.3
Test voltage	Volts	13.5		13.5
Objective values	Watts	2.5 max.		2.5 max.
	Luminous flux	18.6 ± 20 %		
Reference luminous flux: 18.6 lm at approximately 13.5 V				

^{1/} Maximum lateral deviation of filament centre from two mutually perpendicular planes both containing the reference axis and one containing axis X-X.

CATEGORY W3W

Sheet W3W/1

The drawings are intended only to illustrate the essential dimensions (in mm) of the filament lamp

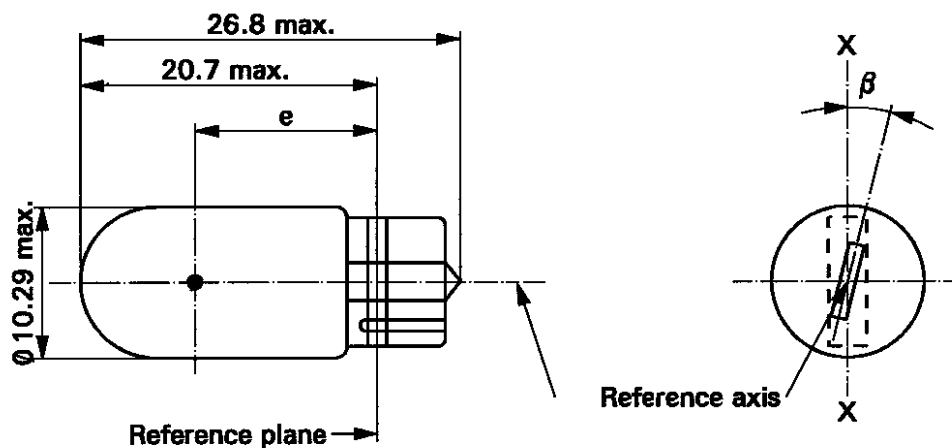

Dimensions in mm	Filament lamps of normal production			Standard filament lamp	
	min.	nom.	max.		
e	11.2	12.7.0	14.2	12.7 ± 0.3	
Lateral deviation ^{1/}			1.5	0.5 max	
β	- 15°	0°	+ 15°	$0^\circ \pm 5^\circ$	
Cap W2.1x9.5d in accordance with IEC Publication 60061 (sheet 7004-91-3)					
ELECTRICAL AND PHOTOMETRIC CHARACTERISTICS					
Rated values	Volts	6	12	24	12
	Watts	3			3
Test voltage	Volts	6.75	13.5	28.0	13.5
Objective values	Watts	3.45 max.		4.6 max.	3.45 max.
	Luminous flux	22 \pm 30 %			
Reference luminous flux: 22 lm at approximately 13.5 V					

^{1/} Maximum lateral deviation of filament centre from two mutually perpendicular planes both containing the reference axis and one containing axis X-X.

CATEGORY W5W, WY5W and WR5W

Sheet W5W/1

The drawings are intended only to illustrate the essential dimensions (in mm) of the filament lamp

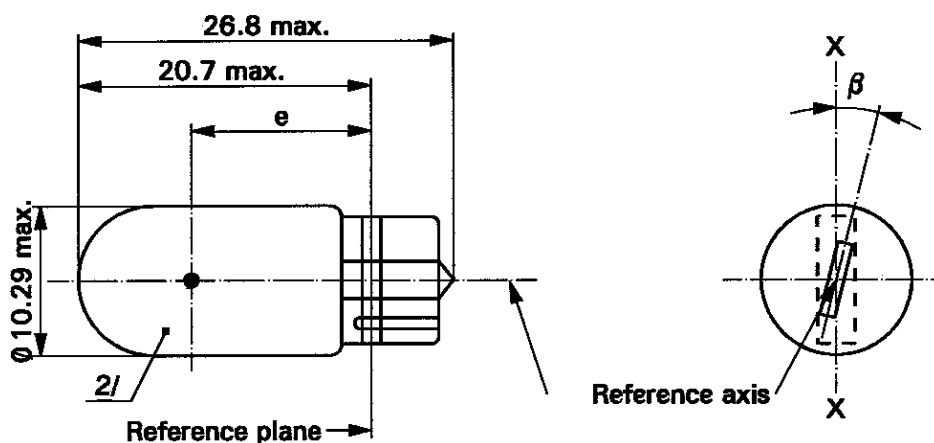

Dimensions in mm		Filament lamps of normal production			Standard filament lamp
		min.	nom.	max.	<u>3/</u>
e		11.2	12.7	14.2	12.7 ± 0.3
Lateral deviation	<u>1/</u>			1.5	0.5 max.
β		- 15°	0°	+ 15°	0° ± 5°
Cap W2.1x9.5d in accordance with IEC Publication 60061 (sheet 7004-91-3)					
ELECTRICAL AND PHOTOMETRIC CHARACTERISTICS					
Rated values	Volts	6 <u>4/</u>	12	24	12
	Watts	5			5
Test voltage	Volts	6.75	13.5	28.0	13.5
Objective values	Watts	5.5 max.		7.7 max.	5.5 max.
	Luminous flux	W5W	50 ± 20 %		
		WY5W	30 ± 20 %		
	WR5W	<u>4/</u>	12 ± 25 %		
Reference luminous flux at approximately 13.5 V:		White:	50 lm		
		Amber:	30 lm		
		Red:	12 lm		

- 1/ Maximum lateral deviation of filament centre from two mutually perpendicular planes both containing the reference axis and one containing axis X-X.
- 2/ The light emitted from filament lamps of normal production shall be white for category W5W, amber for category WY5W and red for category WR5W (see also note 3/.)
- 3/ The light emitted from standard filament lamps shall be white for category W5W; white or amber for category WY5W; white or red for category WR5W.
- 4/ Within WR5W no 6 V rated voltage type specified .

CATEGORY W16W

Sheet W16W/1

The drawings are intended only to illustrate the essential dimensions (in mm) of the filament lamp

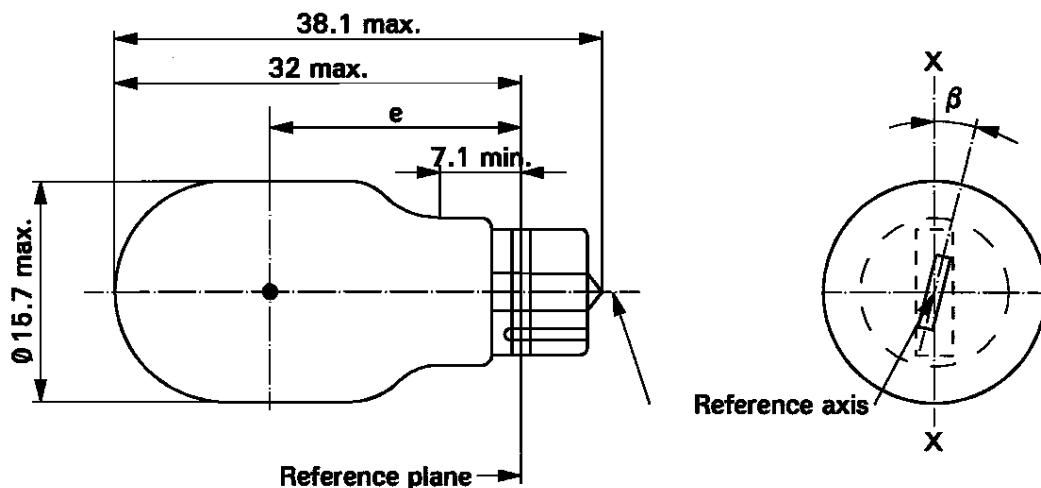

Dimensions in mm	Filament lamps of normal production			Standard filament lamp
	min.	nom.	max.	
e	18.3	20.6	22.9	20.6 ± 0.3
Lateral deviation ^{1/}			1.0	0.5 max.
β	-15°	0°	+ 15°	$0^\circ \pm 5^\circ$
Cap W2.1x9.5d in accordance with IEC Publication 60061 (sheet 7004-91-3)				
ELECTRICAL AND PHOTOMETRIC CHARACTERISTICS				
Rated values	Volts	12		12
	Watts	16		16
Test voltage	Volts	13.5		13.5
Objective values	Watts	21.35 max.		21.35 max.
	Luminous flux	310 \pm 20 %		
Reference luminous flux: 310 lm at approximately 13.5 V				

^{1/} Maximum lateral deviation of filament centre from two mutually perpendicular planes both containing the reference axis and one containing axis X-X.

CATEGORY W21W

Sheet W21W/1

The drawings are intended only to illustrate the essential dimensions (in mm) of the filament lamp

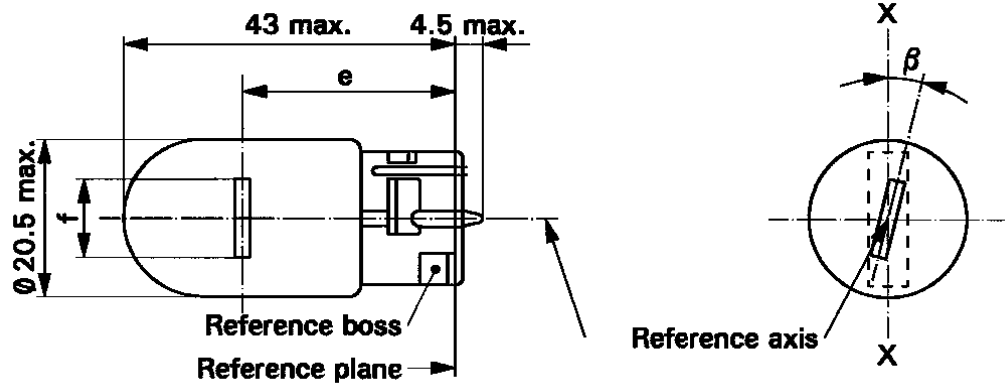

Dimensions in mm	Filament lamps of normal production			Standard filament lamp
	min.	nom.	max.	
e		29.0 <u>2/</u>		29.0 ± 0.3
f			7.5	7.5 + 0/ - 2
Lateral deviation <u>1/</u>			<u>2/</u>	0.5 max.
β	-15° <u>2/</u>	0°	+15° <u>2/</u>	0° ± 5°
Cap W3x16d in accordance with IEC Publication 60061 (sheet 7004-105-2)				
ELECTRICAL AND PHOTOMETRIC CHARACTERISTICS				
Rated values	Volts	12		12
	Watts	21		21
Test voltage	Volts	13.5		13.5
Objective values	Watts	26.5 max.		26.5 max.
	Luminous flux	460 ± 15 %		
Reference luminous flux: 460 lm at approximately 13.5 V				

1/ Maximum lateral deviation of filament centre from two mutually perpendicular planes both containing the reference axis and one containing axis X-X.

2/ To be checked by means of a "Box-System"; see sheet W21W/2.

Screen projection requirements

This test is used to determine, by checking whether the filament is correctly positioned relative to the reference axis and reference plane and has an axis perpendicular, within $\pm 15^\circ$, to the plane through the axis X-X and the reference axis, whether a filament lamp complies with the requirements.

Side elevation

Front elevation

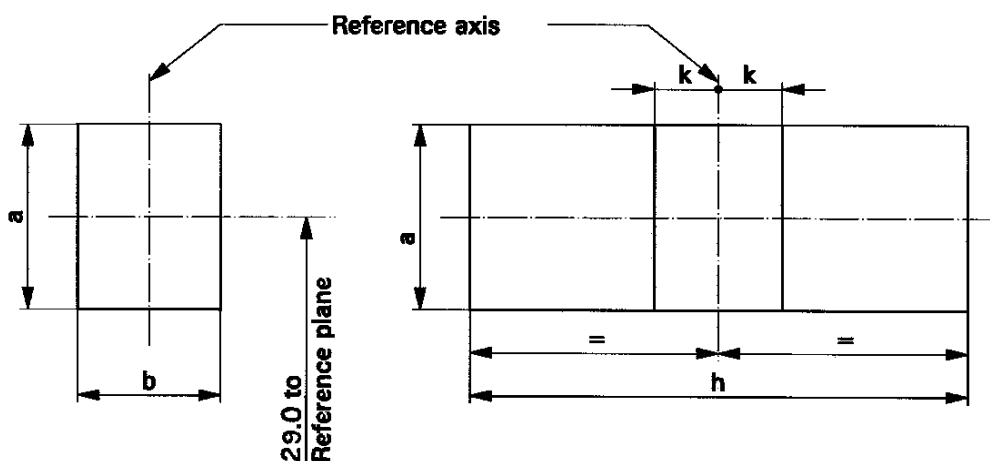

Reference	a	b	h	k
Dimension	3.5	3.0	9.5	1.0

Test procedures and requirements.

1. The filament lamp is placed in a holder capable of being rotated about its axis and having either a calibrated scale or fixed stops corresponding to the angular displacement tolerance limits, i.e. $\pm 15^\circ$. The holder is then so rotated that an end view of the filament is seen on the screen on to which the image of the filament is projected. The end view of the filament shall be obtained within the angular displacements tolerance limits ($\pm 15^\circ$).
2. Side elevation
 The filament lamp placed with the cap down, the reference axis vertical and the filament seen end-on, the projection of the filament shall lie entirely within a rectangle of height "a" and width "b", having its centre at the theoretical position of the centre of the filament.
3. Front elevation
 The filament lamp placed with the cap down and the reference axis vertical, the filament lamp being viewed in a direction at right angles to the filament axis:
 - 3.1. the projection of the filament shall lie entirely within a rectangle of height "a" and width "h", having its centre at the theoretical position of the centre of the filament;
 - 3.2. the centre of the filament shall not be offset by more than distance "k" from the reference axis.

CATEGORY W21/5W

Sheet W21/5W/1

The drawings are intended only to illustrate the essential dimensions (in mm) of the filament lamp.

a = major (high wattage) filament
b = minor (low wattage) filament

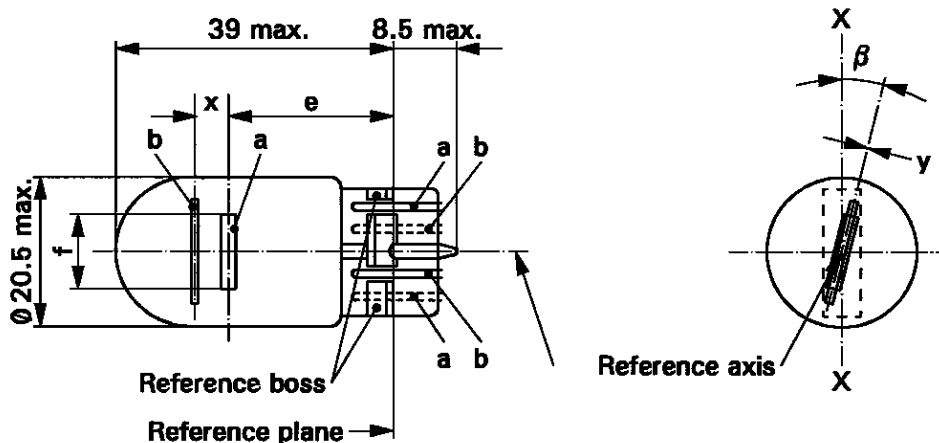

Dimensions in mm	Filament lamps of normal production			Standard filament lamp		
	min.	nom.	max.			
e		25.0 <u>1/</u>		25.0 ± 0.3		
f			7.5	7.5 + 0/ - 2		
Lateral deviation <u>2/</u>			<u>1/</u>	0.3 max.		
x <u>3/</u>		2.8 <u>1/</u>		2.8 ± 0.3		
y <u>3/</u>		0.0 <u>1/</u>		0.0 ± 0.3		
β	-15° <u>1/</u>	0°	+15° <u>1/</u>	0° ± 5°		
Cap W3x16q in accordance with IEC Publication 60061 (sheet 7004-106-2)						
ELECTRICAL AND PHOTOMETRIC CHARACTERISTICS						
Rated values	Volts	12			12	
	Watts	21	5		21	5
Test voltage	Volts	13.5			13.5	
Objective values	Watts	26.5 max.	6.6 max.		26.5 max.	6.6 max.
	Luminous flux	440 ± 15 %	35 ± 20 %			
Reference luminous flux: 440 and 35 lm at approximately 13.5 V						

- 1/ To be checked by means of a "Box-System"; sheets W21/5W/2 and 3.
2/ Maximum lateral deviation of filament centre from two mutually perpendicular planes both containing the reference axis and one containing axis X-X.
3/ "x" and "y" denote the offset of the axis of the minor filament with respect to the axis of the major filament.

Screen projection requirements

This test is used to determine, by checking whether:

- (a) the major filament is correctly positioned relative to the reference axis and reference plane and has an axis perpendicular, within $\pm 15^\circ$, to the plane through the axis X-X and the reference axis; and whether:
- (b) the minor filament is correctly positioned relative to the major filament, whether a filament lamp complies with the requirements.

Test procedure and requirements.

1. The filament lamp is placed in a holder capable of being rotated about its axis and having either a calibrated scale or fixed stops corresponding to the angular displacement tolerance limits. The holder is then so rotated that an end view of the major filament is seen on the screen on which the image of the filament is projected. The end view of that filament shall be obtained within the angular displacement tolerance limits ($\pm 15^\circ$).
2. Side elevation
The filament lamp placed with the cap down, the reference axis vertical and the major filament seen end-on:
 - 2.1. the projection of the major filament shall lie entirely within a rectangle of height "a" and width "b", having its centre at the theoretical position of the centre of the filament;
 - 2.2. the projection of the minor filament shall lie entirely within a rectangle of width "c" and height "d" having its centre at a distance "u" above the theoretical position of the centre of the major filament.
3. Front elevation
The filament lamp being placed with the cap down and the reference axis vertical, the filament lamp being viewed in a direction at right angles to axis of the major filament:
 - 3.1. the projection of the major filament shall lie entirely within a rectangle of height "a" and width "h", centred on the theoretical position of the centre of the filament;
 - 3.2. the centre of the major filament shall not be offset by more than distance "k" from the reference axis;
 - 3.3. the centre of the minor filament axis shall not be offset from the reference axis by more than ± 2 mm (± 0.4 mm for standard filament lamps).

Side elevation

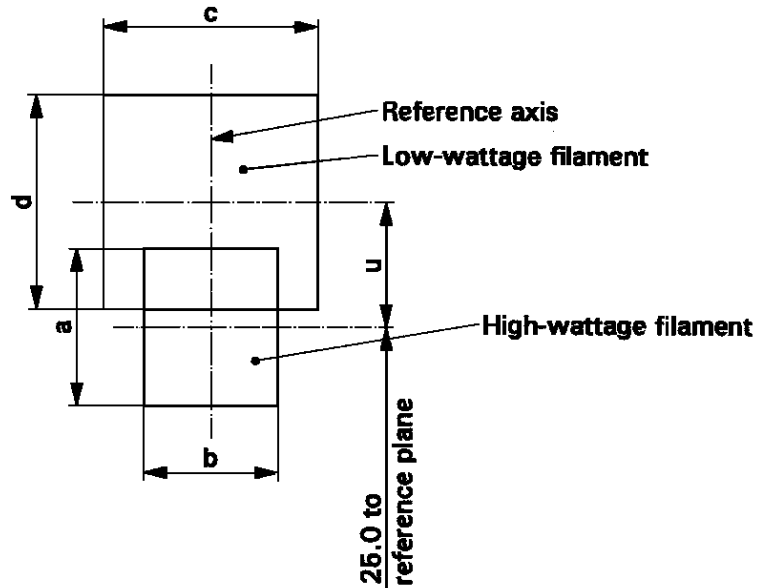

Reference	a	b	c	d	u
Dimensions	3.5	3.0	4.8		2.8

Front elevation

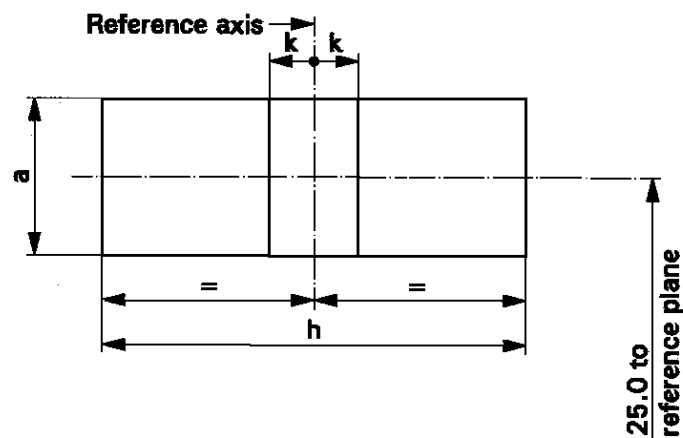

Reference	a	h	k
Dimensions	3.5	9.5	1.0

CATEGORIES WP21W AND WPY21W

Sheet WP21W/1

The drawings are intended only to illustrate the essential dimensions (in mm) of the filament lamp

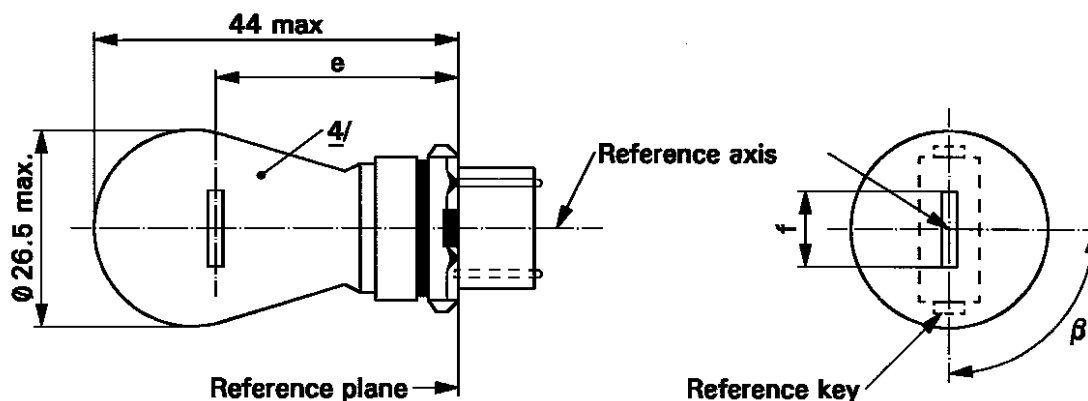

Dimensions in mm	Filament lamps of normal production			Standard filament lamp
	min.	nom.	max.	
e		27.9 <u>3/</u>		27.9 ± 0.3
f	5.5	6.0	7.0	6.0 ± 0.5
Lateral deviation <u>2/</u>			<u>3/</u>	0.0 ± 0.4
β	75° <u>3/</u>	90°	105° <u>3/</u>	$90^\circ \pm 5^\circ$
Cap:	WP21W: WY2.5x16d WPY21W: WZ2.5x16d	in accordance with IEC Publication 60061		(sheet 7004-104B-1) (sheet 7004-104C-1)
ELECTRICAL AND PHOTOMETRIC CHARACTERISTICS				
Rated values	Volts	12		12
	Watts	21		21
Test voltage	Volts	13.5		13.5
Objective values	Watts		26.5 max.	26.5 max.
	Luminous flux	WP21W	$460 \pm 15\%$	
		WPY21W	$280 \pm 20\%$	
Reference luminous flux at approximately 13.5 V		White:	460 lm	
		Amber:	280 lm	

- 1/ The reference axis is defined with respect to the reference keys and is perpendicular to the reference plane.
- 2/ Maximum lateral deviation of filament centre from two mutually perpendicular planes both containing the reference axis and one containing the axis through the reference keys.
- 3/ To be checked by means of a "Box-System"; sheet WP21W/2.
- 4/ The light emitted from filament lamps of normal production shall be white for category WP21W and amber for category WPY21W (see also footnote 5/.)
- 5/ The light emitted from standard filament lamps shall be white for category WP21W and white or amber for category WPY21W.

CATEGORIES WP21W AND WPY21W

Sheet WP21W/2

Screen projection requirements

This test is used to determine, by checking whether the filament is correctly positioned relative to the reference axis and reference plane and has an axis perpendicular, within $\pm 15^\circ$, to the plane through the centre line of the keys and the reference axis, whether a filament lamp complies with the requirements.

Side elevation

Front elevation

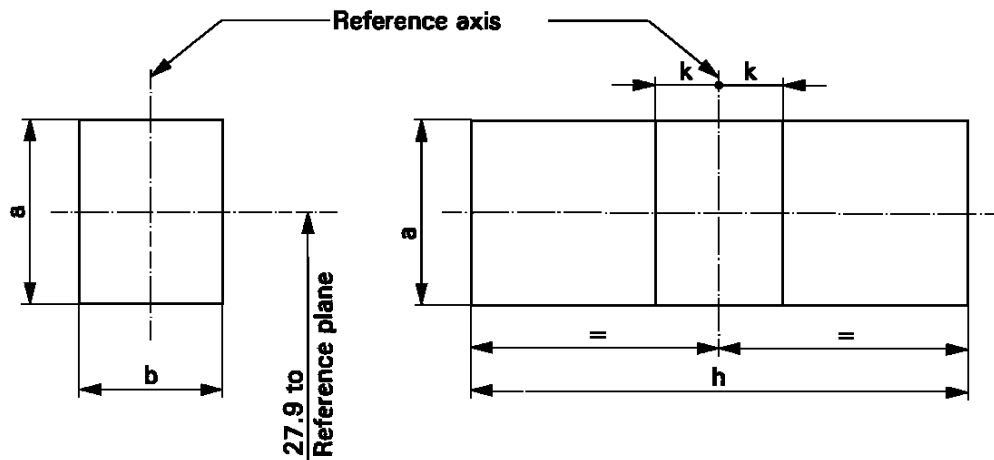

Reference	a	b	h	k
Dimension	3.5	3.0	9.0	1.0

Test procedures and requirements.

1. The filament lamp is placed in a holder capable of being rotated about its axis and having either a calibrated scale or fixed stops corresponding to the angular displacement tolerance limits. The holder is then so rotated that an end view of the filament is seen on the screen on to which the image of the filament is projected. The end view of the filament shall be obtained within the angular displacements tolerance limits.
2. Side elevation
The filament lamp placed with the cap down, the reference axis vertical and the filament seen end-on, the projection of the filament shall lie entirely within a rectangle of height "a" and width "b", having its centre at the theoretical position of the centre of the filament.
3. Front elevation
The filament lamp placed with the cap down and the reference axis vertical, the filament lamp being viewed in a direction at right angles to the filament axis:
 - 3.1. The projection of the filament shall lie entirely within a rectangle of height "a" and width "h", having its centre at the theoretical position of the centre of the filament.
 - 3.2. The centre of the filament shall not be offset by more than distance "k" from the reference axis.

CATEGORY WR21/5W

Sheet WR21/5W/1

The drawings are intended only to illustrate the essential dimensions (in mm) of the filament lamp
 a = major (high wattage) filament
 b = minor (low wattage) filament

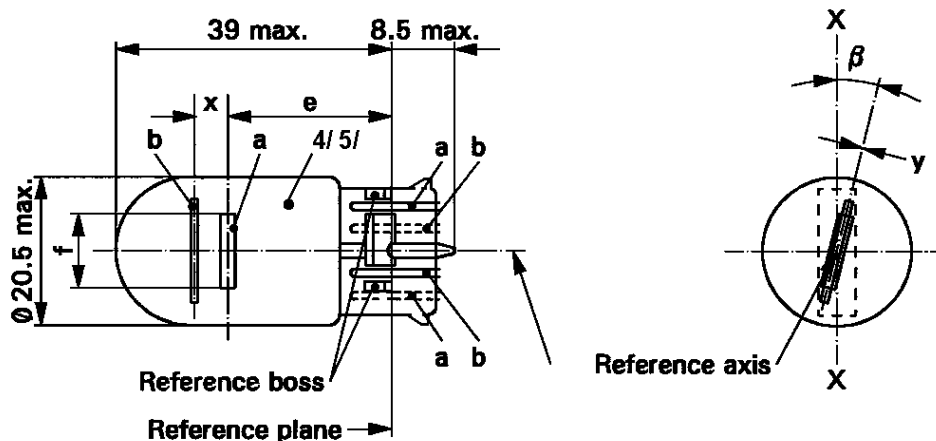

Dimensions in mm	Filament lamps of normal production			Standard filament lamp		
	min.	nom.	max.			
e		25.0 <u>1/</u>		25.0 ± 0.3		
f			7.5	7.5 + 0/ - 2		
Lateral deviation <u>2/</u>			<u>1/</u>	0.3 max.		
x <u>3/</u>		2.8 <u>1/</u>		2.8 ± 0.3		
y <u>3/</u>		0.0 <u>1/</u>		0.0 ± 0.3		
β	-15° <u>1/</u>	0°	+15° <u>1/</u>	0° ± 5°		
Cap WY3x16q in accordance with IEC Publication 60061 (sheet [7004-...-1])						
ELECTRICAL AND PHOTOMETRIC CHARACTERISTICS						
Rated values	Volts	12			12	
	Watts	21	5		21	5
Test voltage	Volts	13.5			13.5	
Objective values	Watts	26.5 max.	6.6 max.		26.5 max.	6.6 max.
	Luminous flux	105 ± 20 %	8 ± 25 %			
Reference luminous flux at approximately 13.5 V		White:	440 lm and 35 lm			
		Red:	105 lm and 8 lm			

- 1/ To be checked by means of a "Box-System"; sheets W21/5W/2 and 3.
2/ Maximum lateral deviation of filament centre from two mutually perpendicular planes both containing the reference axis and one containing axis X-X.
3/ "x" and "y" denote the offset of the axis of the minor filament with respect to the axis of the major filament.
4/ The light emitted from normal production lamps shall be red (see also note 5/).
5/ The light emitted from standard filament lamps shall be white or red.

CATEGORY WY2.3W

Sheet WY2.3W/1

The drawings are intended only to illustrate the essential dimensions (in mm) of the filament lamp

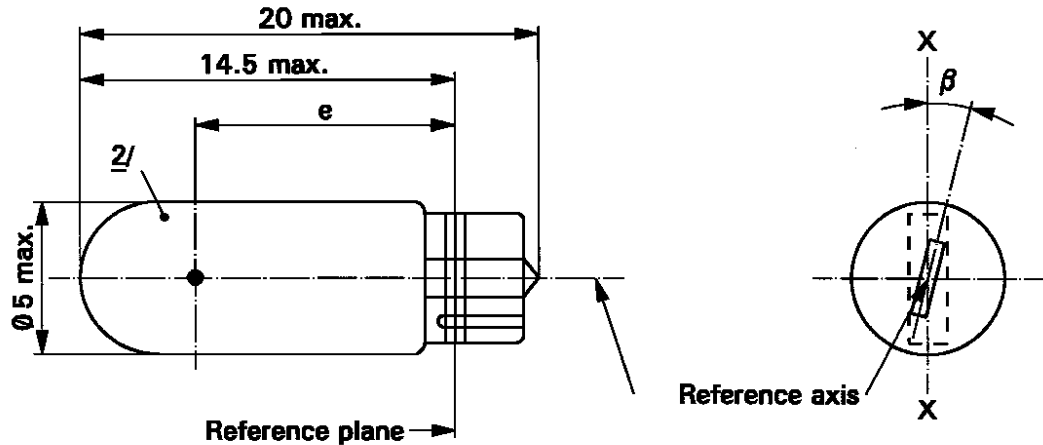

Dimensions in mm		Filament lamps of normal production			Standard filament lamp
		min.	nom.	max.	
e		10.3	10.8	11.3	10.8 ± 0.3
Lateral deviation	$1/$			1.0	0.5 max
β		- 15°	0°	+ 15°	$0^\circ \pm 5^\circ$
Cap W2x4.6d in accordance with IEC Publication 60061 (sheet 7004-94-2)					
ELECTRICAL AND PHOTOMETRIC CHARACTERISTICS					
Rated values	Volts	12			12
	Watts	2.3			2.3
Test voltage	Volts	13.5			13.5
Objective values	Watts	2.5 max.			2.5 max.
	Luminous flux	$11.2 \pm 20 \%$			
Reference luminous flux at approximately 13.5 V		White:	18.6 lm		
		Amber:	11.2 lm		

- $1/$ Maximum lateral deviation of filament centre from two mutually perpendicular planes both containing the reference axis and one containing axis X-X.
- $2/$ The light emitted from production lamps shall be amber (see also note $3/$).
- $3/$ The light emitted from standard filament lamps shall be amber or white.

CATEGORY WY21W

Sheet WY21W/1

The drawings are intended only to illustrate the essential dimensions (in mm) of the filament lamp.

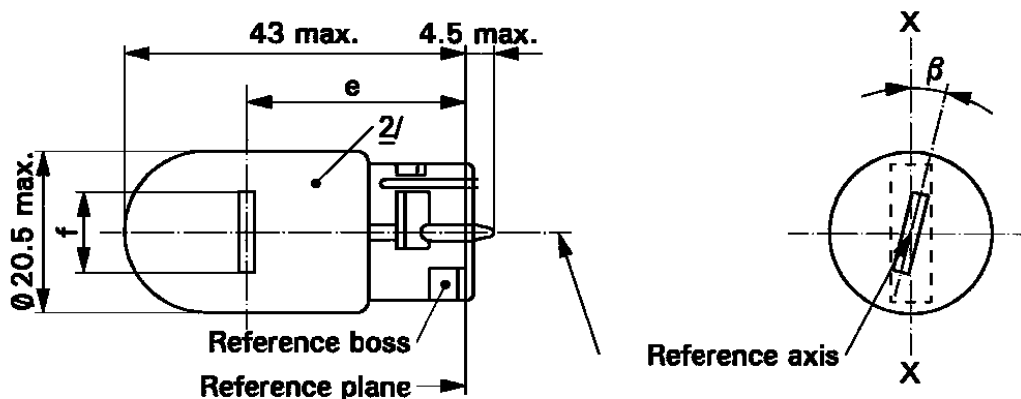

Dimensions in mm		Filament lamps of normal production			Standard filament lamp
		min.	nom.	max.	
e			29.0 <u>2/</u>		29.0 ± 0.3
f				7.5	7.5 + 0/ - 2
Lateral deviation	<u>1/</u>			<u>2/</u>	0.5 max.
β		-15°	0°	+15°	0° ± 5°
Cap WX3x16d in accordance with IEC Publication 60061 (sheet 7004-105-2)					
ELECTRICAL AND PHOTOMETRIC CHARACTERISTICS					
Rated values	Volts	12			12
	Watts	21			21
Test voltage	Volts	13.5			13.5
Objective values	Watts	26.5 max.			26.5 max.
	Luminous flux	280 ± 20 %			
Reference luminous flux at approximately 13.5 V:		White:	460 lm		
		Amber:	280 lm		

- 1/ Maximum lateral deviation of filament centre from two mutually perpendicular planes both containing the reference axis and one containing axis X-X.
- 2/ The light emitted from filament lamps of normal production shall be amber (see also note 4/).
- 3/ To be checked by means of a "Box-System"; sheet WY21W/2.
- 4/ The light emitted from standard filament lamps shall be amber or white.

CATEGORY WY21W

Sheet WY21W/2

Screen projection requirements

This test is used to determine, by checking whether the filament is correctly positioned relative to the reference axis and reference plane and has an axis perpendicular, within $\pm 15^\circ$, to the plane through the axis X-X and the reference axis, whether a filament lamp complies with the requirements.

Side elevation

Front elevation

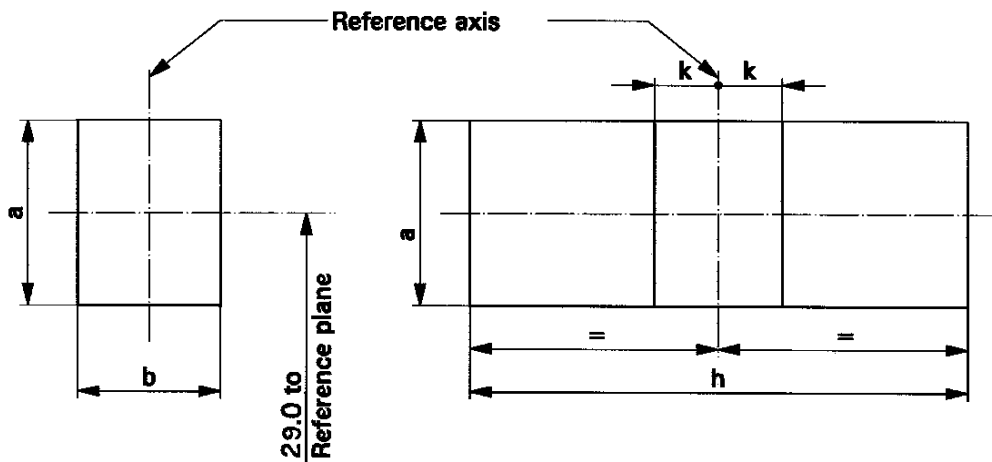

Reference	a	b	h	k
Dimension	3.5	3.0	9.5	1.0

Test procedures and requirements.

1. The filament lamp is placed in a holder capable of being rotated about its axis and having either a calibrated scale or fixed stops corresponding to the angular displacement tolerance limits, i.e. $\pm 15^\circ$. The holder is then so rotated that an end view of the filament is seen on the screen on to which the image of the filament is projected. The end view of the filament shall be obtained within the angular displacements tolerance limits ($\pm 15^\circ$).
2. Side elevation
The filament lamp placed with the cap down, the reference axis vertical and the filament seen end-on, the projection of the filament shall lie entirely within a rectangle of height "a" and width "b", having its centre at the theoretical position of the centre of the filament.
3. Front elevation
The filament lamp placed with the cap down and the reference axis vertical, the filament lamp being viewed in a direction at right angles to the filament axis:
 - 3.1. The projection of the filament shall lie entirely within a rectangle of height "a" and width "h", having its centre at the theoretical position of the centre of the filament.
 - 3.2. The centre of the filament shall not be offset by more than distance "k" from the reference axis.

Annex 2

COMMUNICATION

(maximum format : A4 (210 x 297 mm))

issued by: Name of administration

.....
.....
.....

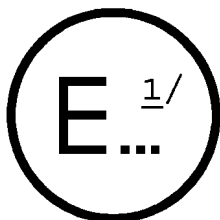

concerning: 2/

- APPROVAL GRANTED
- APPROVAL EXTENDED
- APPROVAL REFUSED
- APPROVAL WITHDRAWN
- PRODUCTION DEFINITELY DISCONTINUED

of a type of filament lamp pursuant to Regulation No. 37

Approval No.

Extension No.

1. Trade name or mark of the device:
2. Manufacturer's name for the type of device:
3. Manufacturer's name and address:
4. If applicable, name and address of manufacturer's representative:
.....
5. Submitted for approval on:
6. Technical service responsible for conducting approval tests:
.....
7. Date of report issued by that service:

8. Number of report issued by that service:.....
9. Concise description:
- Category of filament lamp:.....
- Rated voltage:
- Rated wattage:
- Colour of the light emitted: White/selective-yellow/amber/red 2/
- Halogen filament lamp: yes/no 2/
10. Position of the approval mark:.....
11. Reason(s) for extension (if applicable):.....
12. Approval granted/refused/extended/withdrawn: 2/
13. Place:
14. Date:.....
15. Signature:.....
16. The following documents, bearing the approval mark shown above, are available on request:.....

1/ Distinguishing number of the country which has granted/extended/refused/withdrawn approval (see approval provisions in the Regulation).

2/ Strike out what does not apply.

Annex 3

EXAMPLE OF THE ARRANGEMENT OF THE APPROVAL MARK

(see paragraph 2.4.3.)

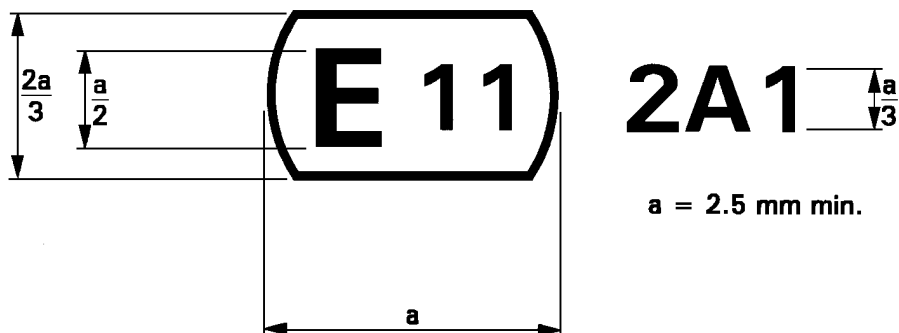

The above approval mark affixed to a filament lamp indicates that the lamp has been approved in the United Kingdom (E11) under the approval code A1.

The first character of the approval code indicates that the approval was granted in accordance with the requirements of Regulation No. 37 as amended by the 02 and 03 */ series of amendments.

*/ Not requiring changes in the approval number.

Annex 4

LUMINOUS CENTRE AND SHAPES OF LAMP FILAMENTS

Save as possibly otherwise stated on the filament lamp data sheets, this standard is applicable to the determination of the luminous centre of different filament shapes.

The position of the luminous centre depends upon the filament shape.

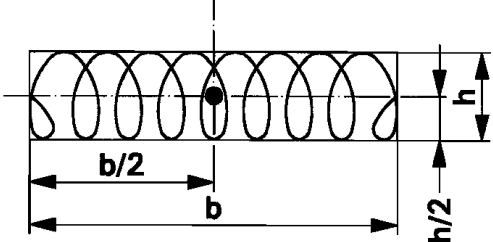
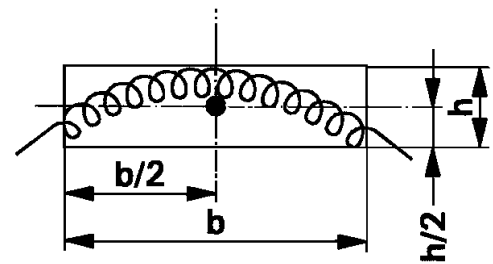
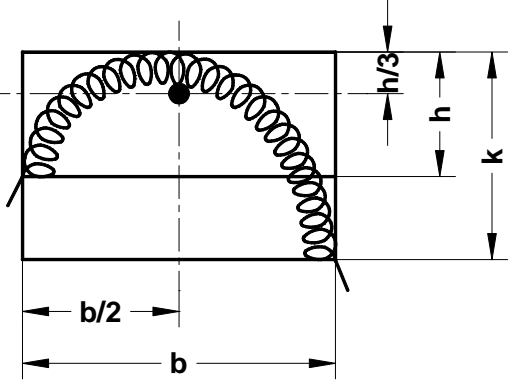
No.	Filament shapes	Observations
1		<p>With $b > 1.5 h$, the deviation of the filament axis with respect to a plane normal to the reference axis shall not exceed 15°</p>
2		<p>Only applicable to filaments which can be inscribed in a rectangle of $b > 3h$.</p>
3		<p>Applicable to filaments which can be inscribed in a rectangle of $b \leq 3h$, whereby, however, $k < 2h$.</p>

The side lines of the circumscribed rectangles in Nos. 2 and 3 are parallel and perpendicular, respectively, to the reference axis.

The luminous centre is the intersection of the dash-dot lines.

The drawings are intended only to demonstrate the essential dimensions.

Annex 5

CHECKING THE COLOUR OF FILAMENT LAMPS

1. General
 - 1.1. Measurements shall be made on finished lamps. Filament lamps with secondary (outer) bulb acting as colour filter shall be handled as filament lamp with primary bulb.
 - 1.2. Tests shall be made at an ambient temperature of $23\text{ °C} \pm 5\text{ °C}$.
 - 1.3. Tests shall be made at test voltage as specified in the relevant lamp data sheet.
 - 1.4. Filament lamps shall be measured preferably in the normal operating position.
 - 1.5. Before starting a test, the stabilisation of the temperature of the filament lamp shall be obtained by operating at test voltage for 10 minutes.
2. Colour
 - 2.1. Colour tests shall be made with a measuring system that determines CIE trichromatic co-ordinates of the received light with an accuracy of ± 0.002 .
 - 2.2. The trichromatic coordinates shall be measured with a colourimetric receiver integrating over a right circular cone subtending an angle of minimum 5° and maximum 15° , at the centre of the filament.
 - 2.3. Measuring directions (see the figure below).
 - 2.3.1. Initially, the receiver shall be positioned perpendicular to the lamp axis and to the filament axis (or plane in case of a curved filament). After measurement the receiver shall be moved around the filament lamp in bi-directional steps of about 30° until the area specified in paragraphs 2.3.2. or 2.3.3. is covered. In each position a measurement shall be made. However, no measurement shall be made when the centreline of the receiver coincides with the filament axis.
 - 2.3.2. For filament lamps used in headlamps, measurements shall be made in directions around the filament lamp with the centreline of the receiver aperture located within an angle $\pm 30^\circ$, from the plane perpendicular to the lamp axis with the origin in the centre of the filament. In case of filament lamps with two filaments, the centre of the driving-beam filament shall be taken.
 - 2.3.3. For filament lamps used in light signalling devices, measurements shall be made randomly around the filament lamp with exception of the area claimed or covered by the cap of the filament lamp, including the immediate transition area. In case of filament lamps with two filaments, the centre of the major filament shall be taken.

FIGURE ILLUSTRATING THE POSITIONS OF COLOURIMETRIC RECEIVER

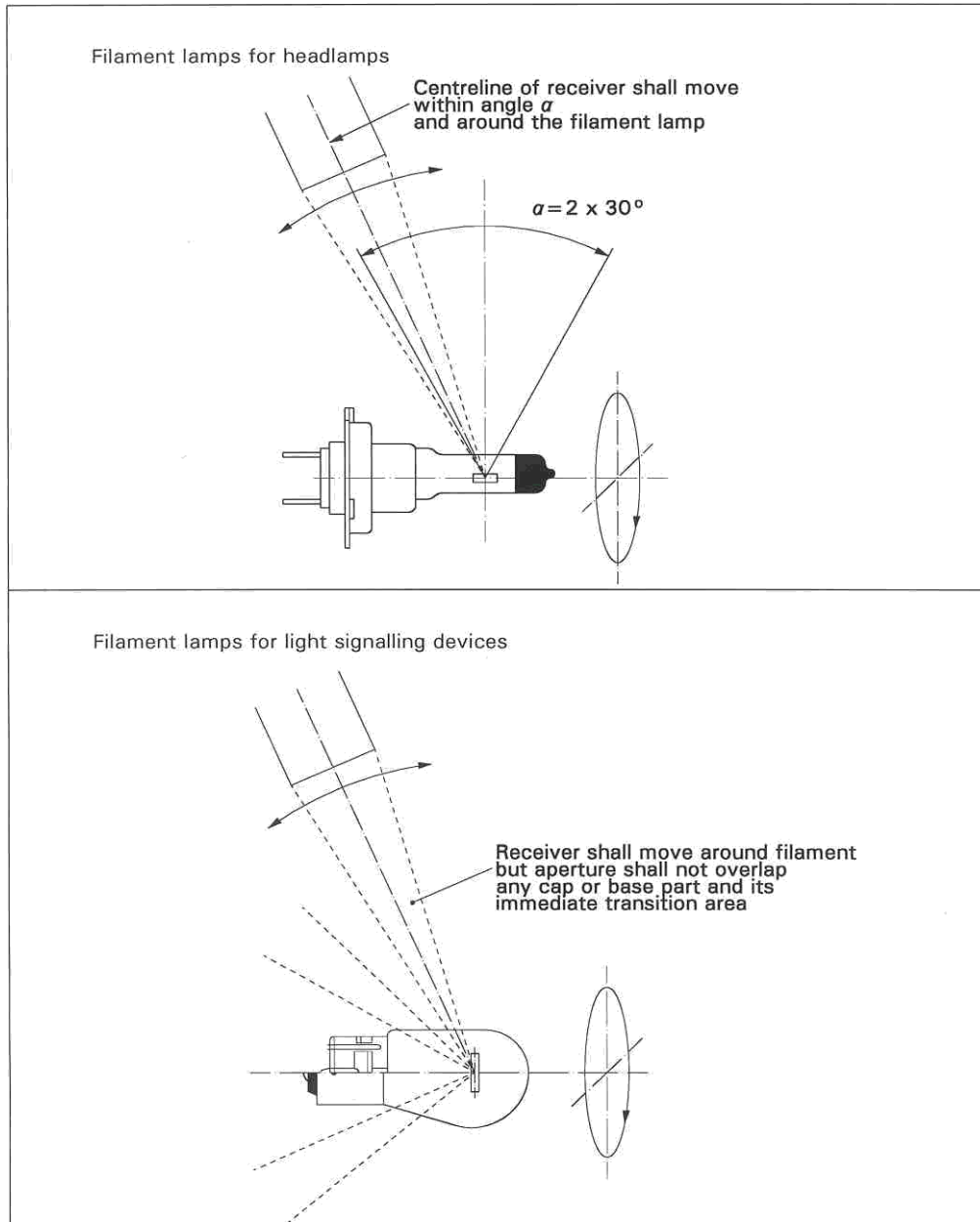

Annex 6

MINIMUM REQUIREMENTS FOR QUALITY CONTROL PROCEDURES BY THE MANUFACTURER

1. General

The conformity requirements shall be considered satisfied from a photometric, geometrical, visual and electrical standpoint if the specified tolerances for production filament lamps in the relevant data sheet of Annex 1 and the relevant data sheet for the caps are met.

2. Minimum requirements for verification of conformity by the manufacturer

For each type of filament lamp the manufacturer or the holder of the approval mark shall carry out tests, in accordance with the provisions of this Regulation, at appropriate intervals.

2.1. Nature of tests

Tests of conformity of these specifications shall cover their photometric, geometrical and optical characteristics.

2.2. Methods used in tests

2.2.1. Tests shall generally be carried out in accordance with the methods set out in this Regulation.

2.2.2. The application of paragraph 2.2.1. requires regular calibration of test apparatus and its correlation with measurements made by a competent authority.

2.3. Nature of sampling

Samples of filament lamps shall be selected at random from the production of a uniform batch. A uniform batch means a set of filament lamps of the same type, defined according to the production methods of the manufacturer.

2.4. Inspected and recorded characteristics

The filament lamps shall be inspected and test results recorded following the grouping of characteristics as listed in Annex 7, Table 1.

2.5. Criteria governing acceptability

The manufacturer or the holder of approval is responsible for carrying out a statistical study of the test results in order to meet the specifications laid down for verification of conformity of production in paragraph 4.1. of this Regulation.

Compliance shall be assured if the level of acceptable non-compliance per grouping of characteristics given in Table 1 of Annex 7 is not exceeded. This means that the number of filament lamps not complying with the requirement for any grouping of characteristics of any filament lamp type does not exceed the qualifying limits in the relevant Tables 2, 3 or 4 of Annex 7.

Note: Each individual filament lamp requirement shall be considered as a characteristic.

Annex 7

SAMPLING AND COMPLIANCE LEVELS FOR MANUFACTURER TEST RECORDS

Table 1 - Characteristics

Grouping of characteristics	Grouping */ of test records between lamp types	Minimum 12 monthly sample per grouping */	Acceptable level of non-compliance per grouping of characteristics (%)
Marking, legibility and durability	All types with the same external dimensions	315	1
Bulb quality	All types with the same bulb	315	1
Colour of the bulb	All coloured bulbs of the same design	315	
External lamp dimensions (excluding cap/base)	All types of the same category	200	1
Dimensions of caps and bases	All types of the same category	200	6.5
Dimensions related to internal elements **/	All lamps of one type	200	6.5
Initial readings, watts and lumens **/	All lamps of one type	200	1
Colour endurance test	All coloured lamps of one coating technology	20 ***/	1

*/ The assessment shall in general cover series production filament lamps from individual factories. A manufacturer may group together records concerning the same type from several factories, provided these operate under the same quality system and quality management.

**/ In case a filament lamp has more than one inner element (filament, shield) the grouping of characteristics (dimensions, watts, lumens) applies to each element separately.

***/ Representative distribution over categories of lamps using the same colour coating technology and finishing, and that comprises lamps of the smallest and the largest diameter of the outer bulb, each at the highest rated wattage.

Qualifying limits for acceptance based on different numbers of test results for each grouping of characteristics are listed in Table 2 as maximum number of non-compliance. The limits are based on an acceptable level of 1 per cent of non-compliance, assuming an acceptance probability of at least 0.95.

Table 2

Number of test results of each characteristics	Qualifying limits for acceptance
- 200	5
201 - 260	6
261 - 315	7
316 - 370	8
371 - 435	9
436 - 500	10
501 - 570	11
571 - 645	12
646 - 720	13
721 - 800	14
801 - 860	15
861 - 920	16
921 - 990	17
991 - 1,060	18
1,061 - 1,125	19
1,126 - 1,190	20
1,191 - 1,249	21

Qualifying limits for acceptance based on different numbers of test results for each grouping of characteristics are listed in Table 3 given as maximum number of non-compliance. The limits are based on an acceptable level of 6.5 per cent of non-compliance, assuming an acceptance probability of at least 0.95.

Table 3

Number of lamps in records	Qualifying limit	Number of lamps in records	Qualifying limit	Number of lamps in records	Qualifying limit
- 200	21	541 - 553	47	894 - 907	73
201 - 213	22	554 - 567	48	908 - 920	74
214 - 227	23	568 - 580	49	921 - 934	75
228 - 240	24	581 - 594	50	935 - 948	76
241 - 254	25	595 - 608	51	949 - 961	77
255 - 268	26	609 - 621	52	962 - 975	78
269 - 281	27	622 - 635	53	976 - 988	79
282 - 295	28	636 - 648	54	989 - 1,002	80
296 - 308	29	649 - 662	55	1,003 -,1016	81
309 - 322	30	663 - 676	56	1,017 - 1,029	82
323 - 336	31	677 - 689	57	1,030 - 1,043	83
337 - 349	32	690 - 703	58	1,044 - 1,056	84
350 - 363	33	704 - 716	59	1,057 - 1,070	85
364 - 376	34	717 - 730	60	1,071 - 1,084	86
377 - 390	35	731 - 744	61	1,085 - 1,097	87
391 - 404	36	745 - 757	62	1,098 - 1,111	88
405 - 417	37	758 - 771	63	1,112 - 1,124	89
418 - 431	38	772 - 784	64	1,125 - 1,138	90
432 - 444	39	785 - 798	65	1,139 - 1,152	91
445 - 458	40	799 - 812	66	1,153 - 1,165	92
459 - 472	41	813 - 825	67	1,166 - 1,179	93
473 - 485	42	826 - 839	68	1,180 - 1,192	94
486 - 499	43	840 - 852	69	1,193 - 1,206	95
500 - 512	44	853 - 866	70	1,207 - 1,220	96
513 - 526	45	867 - 880	71	1,221 - 1,233	97
527 - 540	46	881 - 893	72	1,234 - 1,249	98

Qualifying limits for acceptance based on different numbers of test results for each grouping of characteristics are listed in Table 4 given as a percentage of the results, assuming an acceptance probability of at least 0.95.

Table 4

Number of test results of each characteristic	Qualifying limits shown as a percentage of results. Acceptable level of 1% of non-compliance	Qualifying limits shown as a percentage of results. Acceptable level of 6.5% of non-compliance
1,250	1.68	7.91
2,000	1.52	7.61
4,000	1.37	7.29
6,000	1.30	7.15
8,000	1.26	7.06
10,000	1.23	7.00
20,000	1.16	6.85
40,000	1.12	6.75
80,000	1.09	6.68
100,000	1.08	6.65
1,000,000	1.02	6.55

Annex 8

MINIMUM REQUIREMENTS FOR SPOT CHECKS
BY THE ADMINISTRATIVE AUTHORITY

1. General

- The conformity requirements shall be considered satisfied from a photometric, geometrical, visual and electrical standpoint if the specified tolerances for production filament lamps in the relevant data sheet of Annex 1 and the relevant data sheet for the caps are met.
2. The conformity of mass-produced filament lamps shall not be contested if the results are in agreement with Annex 9 to this Regulation.
 3. Conformity shall be contested and the manufacturer requested to make the production meet the requirements if the results are not in agreement with Annex 9 to this Regulation.
 4. If paragraph 3 of this annex is applied, a further sample of 250 filament lamps, selected at random from a recent production run, shall be taken within two months.

Annex 9

COMPLIANCE APPROVED BY SPOT CHECK

Compliance approved or disapproved shall be decided according to the values in Table 1. For each grouping of characteristics filament lamps shall be either accepted or rejected according to the values in Table 1 */.

Table 1

	1 % <u>**/</u>		6.5 % <u>**/</u>	
	Accept	Reject	Accept	Reject
First sample size: 125	2	5	11	16
If the number of non-conforming units is greater than 2 (11) and less than 5 (16) take a second sample size of 125 and assess the 250	6	7	26	27

*/ The proposed scheme is designed to assess the compliance of filament lamps to an acceptance level of non-compliance of 1 per cent and 6.5 per cent respectively and is based on the Double Sampling Plan for Normal Inspection in IEC Publication 60410: Sampling Plans and Procedures for Inspection by Attributes.

**/ The filament lamps shall be inspected and test results recorded following the grouping of characteristics as listed in Annex 7, Table 1.
