

# Operator's Manual

**Mark 23**

**Pistol, Semi-automatic, Caliber .45 ACP  
NSN 1005-01-426-8951**



**HK<sup>®</sup>**

## SAFETY RULES

### Please read this operators manual before handling your firearm

The following safety rules are placed in this manual by Heckler & Koch as an important reminder that firearms safety is your responsibility. Firearms can be dangerous and can potentially cause serious injury, damage to property or death, if handled improperly.

1. Never point a firearm at anyone, or in any direction other than a SAFE direction, i.e. downrange.
2. Treat all firearms as if they are always loaded.
3. Keep your finger off the trigger and outside of the trigger guard until your sights are aligned on the target.
4. Keep your finger off the trigger and outside of the trigger guard while loading or unloading the firearm.
5. Keep your finger off the trigger and outside of the trigger guard while pulling the firearm out of the holster or while returning it to the holster.
6. Be sure of your target and the back stop beyond.
7. Never give a firearm to or take a firearm from anyone unless the action is open and the magazine and/or chamber are free of any ammunition or brass.
8. Be sure that the ammunition you are using is factory loaded, is of the correct caliber for the firearm in which it is to be used, and that it is not damaged in any way.
9. Before firing, remove the magazine from the firearm, lock the action open, make sure the chamber is clear of any ammunition or brass, and check the barrel of the **unloaded** firearm for any possible obstructions.
10. Before firing any firearm that is unfamiliar to you, make sure that you understand exactly how it functions. A lack of familiarity with the firearm can result in serious accidents. Attend a certified training course on any firearm which you intend to use or with which you are not sufficiently familiar.
11. Always wear hearing and eye protection when using your firearm.
12. Keep all body parts, especially the hands and fingers, away from the muzzle to avoid injury or burns.
13. Be sure that no part of either hand touches or interferes with the slide. The slide is moved backwards by the recoil force of the pistol during firing and may cause serious injury.
14. Firearms should be stored separately from ammunition and beyond the reach of children, and/or any untrained individuals.
15. Avoid the use of any alcoholic beverages or drugs before and during the use of any firearm.
16. Discharging firearms in poorly ventilated areas, cleaning firearms, or handling ammunition may result in exposure to lead and other substances known to cause birth defects, reproductive harm, and other serious physical injury. Have adequate ventilation at all times. Wash hands thoroughly after exposure.

### STOP! KNOW HOW TO CLEAR THIS PISTOL BEFORE ATTEMPTING TO OPERATE.

**Clearing the Pistol** The HK Mark 23 pistol is not considered "clear" or safe unless:

1. The magazine is removed.
2. The slide is locked to the rear.
3. The chamber is free of brass or ammunition.
4. The safety lever is set on "safe".

**NEVER ASSUME THE PISTOL IS CLEAR!** To Clear the HK Mark 23:

1. **Make sure fingers are outside of the trigger guard and the pistol is pointed in a safe direction at all times!**
2. **Decock Hammer or Engage Safety** - depress decocking lever or engage the safety lever.
3. **Remove Magazine** - depress the magazine release lever and remove the magazine from the frame.
4. **Open Slide** - lock slide open by pulling slide rearward as you engage the slide release lever (up). Watch for live round or empty case to be ejected.
5. **Inspect Chamber** - inspect chamber for the presence of a live round or empty case:
  - a. Visually view chamber through ejection port.
  - b. Physically insert finger into chamber through ejection port and check for presence of cartridge case in chamber.
  - c. Remove any live rounds or empty cases from the chamber or from within the weapon.

The HK Mark 23 Pistol is now considered "Clear".

# Operator's Manual

## Mark 23 Pistol, Semi-automatic, Caliber .45 ACP



© Heckler & Koch, Inc., October 1996 (February 2004 Edition)  
21480 Pacific Blvd.

Sterling, Virginia 20166-8903  
United States of America  
Telephone (703) 450-1900

### **WARNING**

**A firearm has the capability of taking your life or the life of someone else! Be extremely careful with your firearm. An accident can occur at anytime and is almost always the result of not following basic safety rules.**

## TABLE OF CONTENTS

	PAGE
CHAPTER 1 INTRODUCTION .....	6
SECTION I GENERAL INFORMATION .....	6
SECTION II PISTOL DESCRIPTION .....	8
1.2 Nomenclature .....	8
1.3 Principle of Operation .....	9
1.4 Major Assembly Groups .....	9
1.5 Technical Specifications .....	11
CHAPTER 2 OPERATING INSTRUCTIONS .....	12
SECTION I SERVICE UPON RECEIPT OF MATERIAL .....	12
2.1 Initial Inspection .....	12
SECTION II GENERAL DESCRIPTION .....	12
2.2 Description .....	12
2.3 Operation and Characteristics .....	13
2.4 Cycle of Operation .....	15
2.5 Safety Features .....	19
SECTION III OPERATION UNDER NORMAL CONDITIONS .....	20
2.6 Clearing Procedures .....	20
2.7 Loading and Unloading the Magazine .....	21
2.8 Loading Procedure .....	22
2.9 Readyng the Pistol for Firing .....	23
2.10 Firing the Pistol .....	24
SECTION IV OPERATION UNDER UNUSUAL CONDITIONS .....	25
2.11 Extreme Cold .....	25
2.12 Hot, Wet Climates .....	25
2.13 Hot, Dry Climates .....	26
2.14 Heavy Rain and Water Operations - All Climates .....	26

SECTION V	MALFUNCTIONS AND STOPPAGES .....	27
	2.15 Remedial Action .....	27
CHAPTER 3	MAINTENANCE INSTRUCTIONS .....	29
SECTION I	TOOLS & EQUIPMENT .....	29
	3.1 Operator Tools and Equipment Required .....	29
SECTION II	PMS CHECKS & MAINTENANCE PROCEDURES .....	29
	3.2 General .....	29
	3.3 Disassembly (Field stripping) .....	30
	3.4 Reassembly (From field strip) .....	32
	3.5 Safety/Function Check .....	35
	3.6 Function Firing .....	38
	3.7 Cleaning .....	38
	3.8 Inspection .....	39
	3.9 Lubrication .....	40
SECTION III	ADJUSTMENT OF SIGHTS .....	42
SECTION IV	TROUBLESHOOTING PROCEDURES .....	45
	3.10 Operator Troubleshooting Procedures .....	45
	3.11 Parts Listing and Exploded Diagram .....	48
CHAPTER 4	AMMUNITION .....	50
CHAPTER 5	LOCKOUT .....	51
FIREARM SERVICE RECORD .....	INSIDE BACK COVER	

## CHAPTER 1 INTRODUCTION

### SECTION I - GENERAL INFORMATION

The HK Mark 23 .45 ACP pistol give shooters match grade accuracy equal to that of the finest custom made handguns — yet it exceeds the most stringent operational requirements ever demanded of a combat handgun.

The Mark 23 provides this accuracy without the need for hand-fitted parts common in custom-built match pistols costing thousands of dollars more. Repair of the Mark 23 is reduced to a simple parts exchange.

The HK Mark 23, is a commercial model of the U.S. Government issue MK 23, MOD 0 pistol and is available in limited numbers. Designated the “Mark 23”, it is almost identical to the MK 23, MOD 0 pistol used by the Special Operations Command, right down to its threaded barrel. The main differences are slide Markings (Mark 23 as opposed to MK 23) and a barrel manufactured to SAMMI headspace specifications.

One of the most thoroughly tested handguns in history, the MK23/Mark 23 project originated in 1991 when HK was awarded a development contract for the Special

Operations Forces Offensive Handgun Weapon System, consisting of a caliber .45 pistol, detachable sound and flash suppressor, and laser aiming module (LAM).

During testing, MK 23 pistols met the most stringent operational and accuracy requirements ever demanded of a combat handgun. MK 23 pistols achieved match grade accuracy of less than a 2.5 inch maximum extreme spread in 5-round shot groups at 25 meters with service ammunition. Endurance testing demonstrated a service life of over 30,000 rounds of +P ammunition with no parts breakage, with an additional 30,000 rounds certified on the slide and frame.

To meet the reliability requirement, the pistol had to demonstrate a minimum of 2,000 mean rounds between stoppages (MRBS) with both M1911 ball and +P ammunition. The minimum MRBS achieved in testing was 6,027 and the maximum was 15,122!

During over 450 accuracy test firings from a precision firing fixture, MK 23 pistols far exceeded the government requirement, averaging 1.44 inches, with 65 groups of less than one inch. There were four groups of .5 inches, with 5 rounds going through the same hole! This included firing with and without the sound/flash suppressor attached.

Three pistols were tested for accuracy after firing over 30,000 rounds, the specified service life of the pistol, and still met the new pistol accuracy requirement. An innovative design feature, a high temperature rubber O-ring on the barrel that seals the barrel in the slide until unlocking, led to this remarkable achievement. The O-ring lasts beyond 20,000 rounds and can be replaced by the operator without tools in seconds.

To meet operational environmental requirements, the pistol was function tested at +140 and -25<sup>o</sup> F, immersed in salt water, exposed to surf, salt-fog, sand-dust, mud, icing, unlubricated, and a variety of other fouled environments. A special maritime surface coating protects the pistol from corrosion, in all of these operational environments.

The barrel is threaded to accept accessories such as a flash and sound suppressor. The unique HK polygonal bore profile increases muzzle velocity and service life, reduces bore fouling and eases cleaning.

The frame mounted MK 23 decocking lever is separate from the ambidextrous safety lever. It allows the hammer to be lowered quietly and safely from the single action position. When the hammer is down, the ambidextrous frame mounted safety lever is locked in the fire position so that the pistol is always ready for double action

operation. When the hammer is “cocked and locked” in single action mode with the safety lever on “safe”, the decocker is blocked so that the pistol is always ready for single action operation. Even with the safety lever engaged, the slide can still be manipulated to load and clear the pistol.

The extended slide release lever and the ambidextrous magazine release are easily operated without adjustment of the firing grip using the firing hand thumb or index finger.

Other notable features include accessory mounting grooves on the frame, a mechanical recoil reduction system that reduces recoil forces to the shooter and components of the pistol by as much as 30%, a polymer frame, a one-piece machined steel slide, and a law enforcement/military magazine capacity of twelve rounds. The weapon is aimed using either iron sights or an optional laser aiming component. The iron sights provide a 3-dot sight picture with white or optional self-luminous tritium dots.

The MK 23 became the first caliber .45 ACP pistol to enter U.S. military service since the venerable Government Model 1911A1. On May 1, 1996, the first MK 23 pistols were delivered to the U.S. Special Operations Command for operational deployment.

## SECTION II - PISTOL DESCRIPTION

### 1.2 Nomenclature

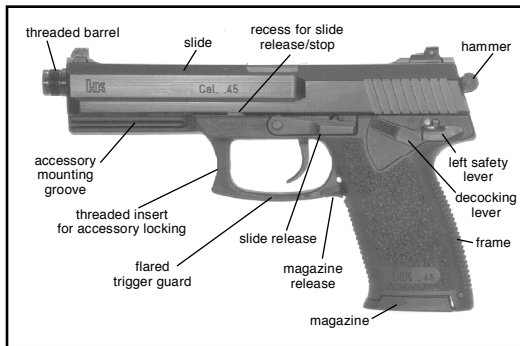

Figure 1 Left View

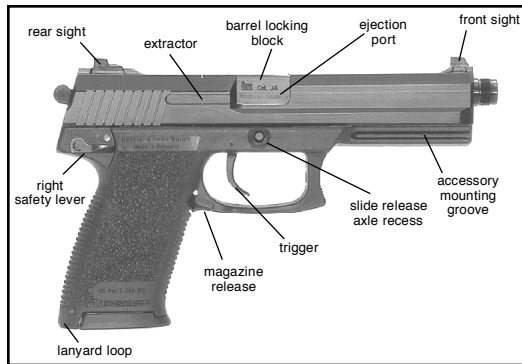

Figure 2 Right View

### 1.3 Principle of Operation

A. The Mark 23 uses a modified linkless Browning-style short recoil system to lock and unlock the breech.

B. Upon firing, the pressure developed by the propellant gas forces the slide and barrel assembly to the rear. After approximately 3 mm, the locking block will stop the rearward movement of the barrel as the barrel is pivoted downward due to the engagement of the angled surfaces of the locking block with those located



in the recoil spring guide rod. The locking block will disengage from the slide and the slide will continue rearward.

The extractor located in the slide will then extract the fired cartridge case, the ejector located in the frame on the left side of the magazine well will eject the fired case as the slide continues rearward and cocks the hammer, and compresses the recoil spring.

The slide moves forward feeding the next cartridge from the magazine into the chamber and locking to the barrel breech.

- C. The slide locks open after the last round has been fired and ejected.

**WARNING**

**Do not rely on the slide lock to determine if the magazine is empty. Always check visually and physically ensure the pistol is not loaded.**

**1.4 Major Assembly Groups** (See Figure 3)

- A. **Slide** - houses the firing pin, firing pin block and

extractor; cocks hammer during recoil.

- B. **Captured Recoil/Buffer Spring Assembly (with guide rod)** - absorbs recoil and returns the slide and barrel to their forward positions; reduces impact of slide on receiver during recoil. The recoil spring is “captured” by a C-clip on the end of the guide rod.
- C. **Threaded Barrel (with locking block)** - contains cartridge and propellant gases during firing. The locking block initiates locking and unlocking of the breech during movement of slide. The O-ring holds the barrel tight in the slide until unlocking.
- D. **Frame** - serves as support to all major components; controls functioning of pistol. The slide release locks the slide with barrel and recoil/buffer spring assembly to the metal locking insert cast into the synthetic frame. A lanyard loop is in the bottom of the grip for attaching a lanyard. The trigger guard is flared on both sides to preclude accidental actuation of the magazine release during holstering.

E. **Magazine** - holds the cartridges in position for feeding and chambering.

F. **Slide Release** - holds slide to rear when engaged; releases slide when lever is depressed.

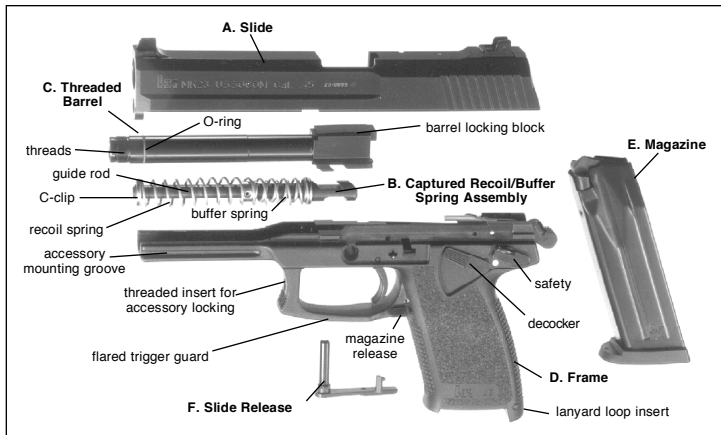

Figure 3 Major Assembly Groups

## 1.5 Technical Specifications:

Caliber	.45 ACP (Automatic Colt Pistol)		
System of Operation	short recoil, semi-automatic		
Locking System	Browning system (modified), linkless		
Length	Barrel	5.87 in.	(149 mm)
	Sight radius	7.76 in.	(197 mm)
	Pistol	9.65 in.	(245 mm)
Weight	Magazine (empty) 12 or 10 rd. capacity	.24 lbs.	(.110 kg)
	Magazine (w/12 rds M1911 Ball)	.81 lbs.	(.366 kg)
	Magazine (w/10 rds M1911 Ball)	.72 lbs.	(.327 kg)
	Pistol (w/ empty 12 or 10 rd magazine)	2.66 lbs.	(1.21 kg)
	Pistol (w/ 12 rds M1911 Ball)	3.22 lbs.	(1.46 kg)
Pistol (w/ 10 rds M1911 Ball)	3.13 lbs.	(1.42 kg)	
Trigger Pull	Single-action	4.85 lbs.	(2.20 kg)
	Double-action	12.13 lbs.	(5.50 kg)
Height	5.90 in. (150 mm)		
Width	1.53 in. (38.8 mm)		
Muzzle velocity	M1911 230 grain ball	886 fps	(270 m/s)
	+P 185 grain JHP	1142 fps	(348 m/s)
Maximum Effective Range	54.7 yds (50 m)		
Maximum Range (M1911 ball)	1,467 yds (1,341 m)		
Rifling	polygonal bore right hand twist		
Magazine	staggered, 12 round capacity (10 round civilian)		
Safety Features	1. safety lever (manual), 2. double-action mode with 12.1 lb. trigger pull, 3. firing pin block, 4. disconnecter		

## CHAPTER 2 OPERATING INSTRUCTIONS

### SECTION I - SERVICE UPON RECEIPT OF MATERIAL

**2.1 Initial Inspection.** Upon initial receipt, the pistol is to be inspected to ensure it was received in proper working order.

<u>Step</u>	<u>Action</u>	<u>Reference</u>
1	Remove pistol and items from container	
2	Remove packing material	
3	Check for missing items	
4	Field strip weapon and inspect for: Missing parts Proper assembly	para. 3.3
5	Clean, dry and lubricate (if necessary)	para. 3.7, 3.9
6	Assemble	para. 3.4
7	Safety/ function check	para. 3.5

### SECTION II - GENERAL DESCRIPTION

**2.2 Description:** The Mark 23 is a semiautomatic, magazine fed, recoil operated, double/single-action pistol, chambered for the .45 ACP cartridge up to, and including, the commercial +P cartridges.

#### **WARNING**

**The Mark 23 incorporates single and double action modes of operation. Anytime the trigger is pulled with the safety lever in the fire (down) position and a round in the chamber, the pistol will fire from either the hammer down (DA) or cocked position (SA).**

### CAUTION

A pair of Universal Mounting Grooves located on the front of the Mark 23 frame allow for a variety of accessories to be used with the pistol. Improperly designed or installed accessories may result in damage to the Mark 23 mounting grooves and/or the Mark 23. Such damage is not covered under warranty. Be certain to use only HK Authorized Accessories and follow installation and precautions carefully.

### NOTE

Accessories designed for the Universal Self-loading Pistol (USP) will not work on the Universal Mounting Grooves of the Mark 23.

## 2.3 Operation and Characteristics

- A. **Double/Single Action** - For double-action (DA), pulling the trigger will cock the hammer and immediately release it discharging a chambered round. To fire the first chambered round in single-action (SA), the hammer must be manually cocked before pulling the trigger. All shots after the first one will be fired single-action because the slide automatically recocks the hammer after each shot.
- B. **Magazine** - The magazine is produced from sheet steel and has a total capacity of 12 rounds. The rounds are positioned within the magazine in a staggered arrangement. Rounds are visible through the viewing holes located along the back side of the magazine housing. The viewing holes are marked with numerals denoting the number of rounds remaining within. The floor plate can be easily removed for disassembly and cleaning of the magazine components.
- C. **Loaded Chamber Indicator** - The Mark 23 pistol does not have a loaded chamber indicator. The extractor does not act as a loaded chamber indicator.
- D. **Decocking Lever** - The decocking lever allows the operator to quietly lower the cocked hammer without concern of an accidental discharge. When the hammer is cocked, it may be lowered

safely by moving the decocking lever fully into the decocking (down) position. The decocking lever cannot be depressed (and therefore does not allow the hammer to be lowered) if the safety lever is engaged. The decocking lever always springs back into its disengaged (up) position due to the spring pressure exerted by the decocking spring.

- E. **Safety Lever** - The safety lever is an ambidextrous “thumb” lever located on the rear of the frame. It is actuated by the firing thumb of the operator. The safety lever blocks the release of the cocked hammer when it is in the engaged (up) “safe” position (See Figure 4a). The safety lever is depressed downward into the “fire” position (See Figure 4b). The safety lever is not spring actuated and therefore must be moved manually from one position to the other by the operator.

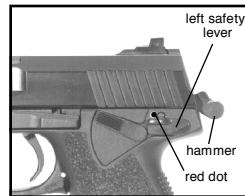
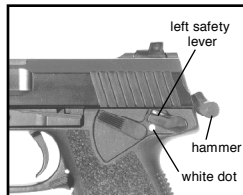

Figure 4a “Safe” Position      Figure 4b “Fire” Position  
The safety lever cannot be placed in the “safe” (up) position if the hammer is uncocked (down).

#### **WARNING**

**The pistol should always be carried with the safety lever engaged when carried in the single action mode. While there is a spring detent to prevent this, the safety lever can be moved to the “fire” position (down) with a minimum amount of force. This could happen during careless handling or during removal of the pistol from the holster. Always check the position of the safety lever during handling.**

F. **Frame** - The front and back straps of the fiberglass reinforced polymer frame are checkered to ensure a firm grip, even with wet hands or under conditions of rapid fire. The trigger guard is extended, recurved and grooved to provide a firm grip when using two hands or gloves. The bottom of the trigger guard is flared on both sides in front of the magazine release lever to shield the lever from accidental actuation.

A threaded insert is molded into the front face of the trigger guard and the frame is grooved forward of the trigger guard for attachment of an accessory such as a laser aiming device or an illuminator. The frame is a one-piece molded component with metal inserts (locking insert and guiding part) cast into the frame during production. The slide rides on these metal inserts during operation.

G. **Slide Release Lever** - This lever is used to lock the slide open and for disassembling the weapon. As a slide stop, it is depressed upward by the magazine follower or the operator's finger as the slide travels rearward during recoil

or manual operation. The slide release lever engages the recess visible on the left side of the slide and is spring actuated. The slide release spring holds the slide release lever in a disengaged (down) position until required. As a disassembly lever, the slide release lever is removed from the left side of the frame when the slide is held rearward (see para. 3.3). The slide release lever can be actuated by the firing thumb of the right handed operator or the index finger of the left handed operator.

H. **Magazine Release Lever** - This ambidextrous, spring actuated lever holds the magazine within the grip by engaging in the notch found in the upper third of the magazine housing. Depressing this lever with the firing hand index finger or thumb will allow the magazine to drop from the grip. The magazine release lever is shielded from accidental actuation by the flared trigger guard and the design of the synthetic frame surrounding the lever.

**2.4 Cycle of Operation.** Begins with weapon loaded, hammer cocked, safety lever disengaged.

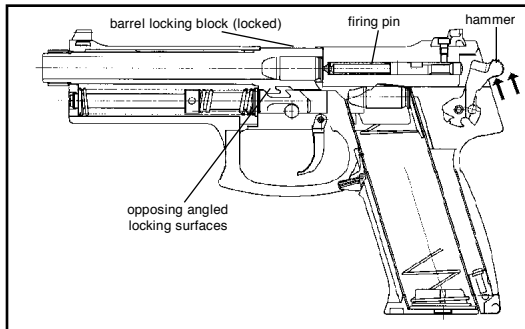

Figure 5 Firing

A. **Firing** - (See Figure 5) Pulling the trigger rearward pulls the trigger bar forward. The trigger bar pivots the sear actuator upwards which disengages the firing pin block. At the same moment, the sear is pivoted out of engagement from the lower of the two shelves located on the hammer. The compressed hammer spring drives the hammer forward into

the rear end of the firing pin. The firing pin strikes the primer of the chambered round. The propellant is ignited by the primer and propellant gases are created inside the cartridge case. The propellant gases drive the projectile down the polygonal bore which spins the projectile in a clockwise direction as a means to stabilize the projectile's flight.

B. **Unlocking** - (See Figure 6) The gas pressure and energy produced by the propellant gases push rearward on the slide, which is locked to the barrel by the engagement of the barrel locking block within the ejection port milled into the slide. The opposing angled locking surfaces incorporated into the design of the barrel locking block and recoil spring guide rod cause the rear of the barrel to tilt downward as the slide moves rearward. By the time the slide and barrel have recoiled approximately 5 mm, the projectile has left the barrel and the gas pressure within the chamber has dropped to a safe level. The barrel locking block then disengages from the slide. The slide is now free to recoil rearward independently of the barrel.



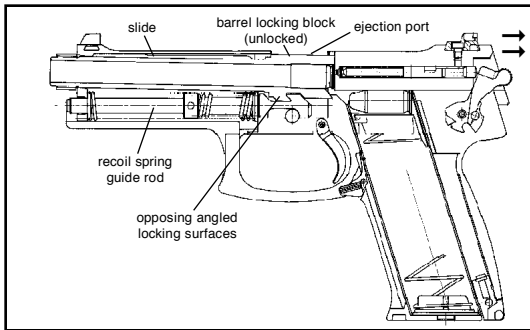

Figure 6 Unlocking

- C. **Extraction** -The empty cartridge case is held firmly against the face of the slide by the claw of the extractor as the slide recoils rearward.
- D. **Ejection** - (See Figure 7) -The rim of the cartridge case strikes the stationary ejector. The empty case is ejected from the open ejection port.

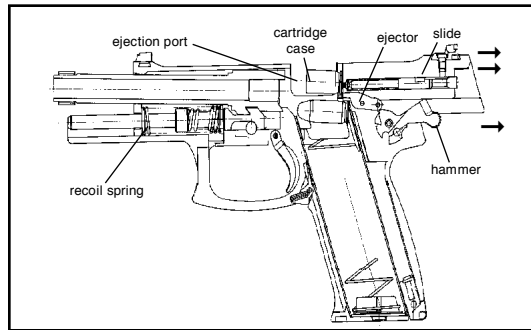

Figure 7 Ejection

- E. **Cocking** - (See Figure 7) - As the slide continues rearward the recoil impulse is dampened by the buffer spring. The recoil spring is compressed and the hammer recocks.

F. **Feeding** - (See Figure 8) -The compressed recoil spring drives the slide forward. If the magazine is empty, the magazine follower will lift the slide release to a point where it will stop the forward progress of the slide. If the magazine is not empty, the face of the slide will make contact with the top round in the magazine. The round will be driven from the magazine towards the chamber. The tip of the projectile is guided into the chamber by the magazine lips until the round clears the magazine completely. At that moment the claw of the extractor snaps onto the rim of the cartridge case as it becomes parallel with the bore.

G. **Chambering** - The slide pushes the cartridge forward until the projectile enters the mouth of the forcing cone of the bore and the face of the slide contacts the rear of the barrel locking block.

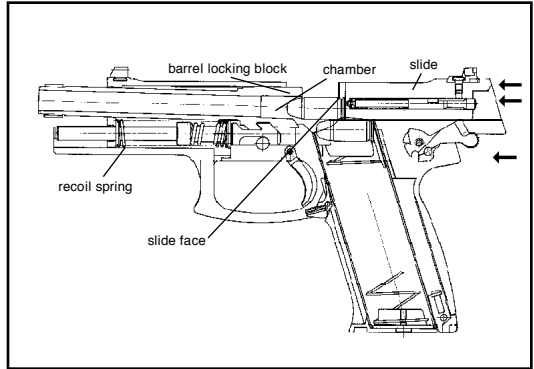

Figure 8 Feeding

H. **Locking** - (See Figure 5) -The slide presses the barrel forward. As it does, the opposing angled surfaces of the barrel locking block and recoil spring guide rod pivot the rear end of the barrel up into engagement with the ejection port in the slide. The slide is now fully forward and the new round is ready to be fired.

## 2.5 Safety Features

- A. **Safety Lever** - This safety blocks the release of the cocked hammer in the SA mode. The safety lever is an external, manually operated, ambidextrous “thumb” lever located on the left and the right side of the frame further most back from the trigger. The safety lever must be manually actuated by the operator. The shaft of the safety lever moves the sear block into a position where it blocks the movement of the sear actuator. The sear actuator, in turn, does not allow the sear to pivot forward and thus the hammer cannot be released. Engaging the safety lever also interrupts the function of the decocking lever and blocks the hammer mechanically. The safety lever does not restrict the movement of the slide. The safety lever is held in either the fire or safe position by a spring detent. The safety lever cannot be placed in the safe (up) position when the hammer is down (uncocked).
- B. **Double-Action Mode** - This safety keeps the hammer in an uncocked condition until the moment of firing. The double-action mode operates as a passive safety feature in the pistol much as this mode of operation would in

any DA revolver or pistol. The hammer is left uncocked until the decision to fire is made. At all times the firing pin is locked by the firing pin block until the trigger is pulled. Approximately 12.1 pounds of pressure on the trigger is required to cock and release the hammer in the DA mode of operation. The mode of operation also permits subsequent hammer strikes on the same chambered round by simply resqueezing the trigger.

- C. **Firing Pin Block** - This safety prevents the firing pin from striking the primer when the weapon is dropped, the hammer is bumped, or when the slide slams forward. The firing pin block is located in the slide and blocks the forward movement of the firing pin. Only when the trigger is depressed can the sear actuator push the firing pin block upward against the downward pressure exerted by the firing pin block spring. Once the round has been fired and the slide begins to recoil, the firing pin block is pushed back down by the firing pin block spring and engages within the recess provided in the center portion of the firing pin.

D. **Disconnecter** - This safety prevents the release of the hammer unless the slide is fully forward and/or the trigger is reset (released) between rounds. This important safety prevents serious malfunctions from occurring, such as “slam-fires” (rounds that fire during loading), automatic fire, or a round being fired out of the battery (with the breech unlocked). The disconnecter disconnects the engagement of the trigger bar and the sear actuator. The disconnecter is engaged (operating) after the slide has moved 2mm to the rear. The slide presses the leading edge of the disconnecter down and into engagement with the trigger bar. When the slide is fully forward, the leading edge of the disengaged disconnecter resides in a recess provided in the bottom of the slide.

## SECTION III - OPERATION UNDER NORMAL CONDITIONS

### WARNING

**Always clear the pistol before handling it.**

### 2.6 Clearing Procedures

- A. The Mark 23 pistol is not considered “clear” or safe unless:
1. The magazine is removed,
  2. The slide is locked to the rear, and
  3. The chamber is free of brass or ammunition.
  4. The safety lever is set on “safe”.

### ***NEVER ASSUME THE PISTOL IS CLEAR!***

#### B. To Clear the Pistol:

1. **Make sure fingers are outside of the trigger guard and the pistol is pointed in a safe direction at all times!**
2. **Decock Hammer or Engage Safety** - depress decocking lever or engage the safety lever.
3. **Remove Magazine** - depress the magazine release lever and remove the magazine from the frame.

4. **Open Slide** - lock slide open by pulling slide rearward as you engage the slide release lever (up). Watch for live round or empty case to be ejected.
  5. **Inspect Chamber** - inspect chamber for the presence of a live round or empty case:
    - a. Visually view chamber through ejection port.
    - b. Physically insert finger into chamber through ejection port and check for presence of cartridge case in chamber.
    - c. Remove any live rounds or empty cases from the chamber or from within the weapon.
2. Hold a round between the index finger and thumb of the other hand with the projectile pointing towards the palm.
  3. Press the rim of the round down against the front edge of the follower or the top round in the magazine and slide the round back under the magazine lips.
  4. Repeat steps 1 - 3 until the magazine is full. The viewing holes in the back of the magazine allow the operator to confirm the number of rounds present within the magazine.

The pistol is now considered “clear”.

## **2.7 Loading and Unloading the Magazine - (See Figure 9)**

The magazine of the Mark 23 pistol holds 10 rounds of .45 caliber ammunition in the commercial magazine and 12 rounds in the Law Enforcement/ Government magazine.

### **A. Loading the Magazine -**

1. Hold the magazine in one hand.

### **WARNING**

**Forcefully inserting a loaded magazine into the Mark 23 may cause the pistol's slide to close, chambering a cartridge and making the Mark 23 ready to fire.**

**When inserting a magazine, always be certain that the pistol is pointed in a safe direction with your fingers off the trigger and outside the trigger guard. Failure to do so could cause you to unintentionally fire the pistol, resulting in serious injury or death.**

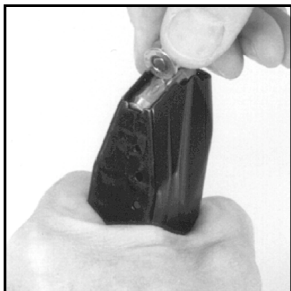

Figure 9 Loading the Magazine

B. **Unloading the Magazine** - exert pressure with the finger on the base of the cartridge case and push each round forward out of the magazine one round at a time until the magazine is empty.

## 2.8 Loading Procedure

A. **Administrative Loading** - used to initially load the pistol before it is to be fired.

### **Method A (Slide rearward, chamber empty)**

1. **Make sure fingers are outside of trigger guard and pistol is pointed in a safe direction at all times!**
2. Insert magazine firmly into the frame. Tug on magazine to insure that it is fully seated and engaged.
3. Depress the slide release lever to release the slide and to chamber the first round.
4. Engage safety lever or depress decocking lever.
5. Remove magazine and top off with one additional round.
6. Reinsert magazine insuring that it is fully seated.

### **Method B (Slide forward, chamber empty)**

1. **Make sure fingers are outside of trigger guard and pistol is pointed in a safe direction at all times!**
2. Insert magazine firmly into the frame. Tug on magazine to insure that it is fully seated and engaged.
3. Retract the slide fully and release. Do not ride slide forward!

4. Engage safety lever or depress decocking lever.
5. Remove magazine and top off with one additional round.
6. Reinsert magazine insuring that it is fully seated.

B. **Tactical Reloading** - used to quickly reload pistol once firing has begun.

**Method A (Slide rearward, chamber empty)**

1. **Make sure fingers are outside of trigger guard and pistol is pointed in a safe direction at all times!**
2. Keep eyes on target area.
3. Depress the magazine release with finger or thumb of firing hand to drop magazine.
4. At the same time, retrieve a full magazine with the non-firing hand and insert firmly into the frame. Tug on magazine to insure that it is fully seated and engaged.
5. Depress slide release to chamber first round.
6. Continue firing.

**Method B (Slide forward, rounds remaining in magazine and chamber)**

1. **Make sure fingers are outside of trigger guard and pistol is pointed in a safe direction at all times!**

2. Keep eyes on target area.
3. Depress the magazine release with finger or thumb of firing hand to drop partially empty magazine.
4. At the same time, retrieve full magazine with non-firing hand and insert firmly into the frame. Tug on the magazine to insure that it is fully seated and engaged.
5. Weapon is now back at full capacity without rendering chamber empty and weapon useless.
6. Continue firing

**2.9 Readyng the Pistol for Firing**

Disengage the safety lever (if engaged). Red hazard dot will be visible above safety lever.

### WARNING

1. **BE SURE OF YOUR TARGET AND WHAT'S BEHIND IT!** Even a .45 caliber projectile can easily penetrate wood, plasterboard walls, or a car door, and can travel as far as one mile!
2. Ensure that all parts of your hand and body are kept away from the muzzle of the pistol at all times!
3. Always wear eye and ear protection where possible when firing the pistol.
4. Whenever the pistol is dropped on a hard surface landing on the hammer (cocked or down), it should be sent to the HK Service Department as soon as practicable to inspect the sear axle. If the sear axle is bent, it should be replaced.

## 2.10 Firing the Pistol

- A. **Single-action mode** (Hammer back/cocked)  
Affords operator the best and lightest trigger pull ( $\approx 4.8$  lbs.) for precise and accurate bullet placement.  
With manual safety disengaged:
1. Aim at the target.
  2. Fire the weapon by pressing the trigger straight

- to the rear with gradually increasing pressure.
3. Engage the safety lever to remain in the single-action mode once firing is completed.

### CAUTION

**Single action mode trigger pull is lighter & shorter than double action mode. Keep your finger off the trigger & outside the trigger guard except when firing the Mark 23.**

- B. **Double-action mode** (Hammer down/uncocked)  
Provides the operator with a long, heavy ( $\approx 12.1$  lbs.) trigger pull for the first shot only. Subsequent shots will be fired in single-action mode as the slide will automatically cock the hammer after each round is fired. The double-action mode of fire is often the preferred mode of fire when safety during handling and carrying is of greater concern than first round accuracy.
1. Aim at the target.
  2. Fire the weapon by pressing the trigger straight to the rear with gradually increasing pressure.
  3. Depress the decocking lever to lower the hammer to return to the double-action mode once firing is complete, or engage the safety lever to remain in the single action mode.



## SECTION IV - OPERATION UNDER UNUSUAL CONDITIONS

### NOTE

**Unusual conditions are defined as any climatic condition requiring special maintenance of the pistol. Perform the maintenance outlined for the climate that most applies to your operational area. Refer to paragraph 3.9 for lubrication instructions.**

### CAUTION

**If extensive corrosion is found and cleaning does not solve the problem, contact the HK Service Department.**

#### 2.11 Extreme Cold

- A. When operating pistol in extremely cold climates, clean and lubricate the pistol inside at room temperature if possible.
- B. Apply a light coat of LAW (Lubricant, Arctic Weapons) to all functional parts.
- C. To prevent freezing, keep the pistol covered when moving from a warm to a cold area. This

will allow gradual cooling.

- D. Always keep the pistol dry.
- E. Do not lay a hot pistol in snow or ice.
- F. Keep ammunition dry; moisture will cause malfunctions. Do not lubricate the ammunition.
- G. Always keep snow out of the bore of the barrel. If snow should get into the bore, clean the bore before firing using a swab and cleaning rod.

#### 2.12 Hot, Wet Climates

- A. Perform maintenance more frequently. Inspect hidden surfaces for corrosion. If corrosion is found, clean and lubricate.
- B. To help prevent corrosion, remove hand prints with a cloth. Dry and lubricate the pistol with CLP/LSA (Cleaner, Lubricant, Protectant).
- C. Check ammunition and magazines frequently for corrosion. Clean the magazine using CLP/LSA and wipe dry with a cloth. If necessary, clean ammunition with a dry cloth.
- D. Always keep mud out of the barrel. If mud should get into the bore, clean it before firing using a swab and cleaning rod.

### **2.13 Hot, Dry Climates**

- A. Dust and sand will get into pistol and cause malfunctions and excessive wear on component contact surfaces during firing. Keep the pistol covered when possible.
- B. Corrosion is less likely to form on metal parts in a dry climate. Therefore, lightly lubricate internal working surfaces only with CLP/LSA. Do not lubricate external parts of the pistol. Wipe any excess lubricant from exposed surfaces. Do not lubricate internal components of magazine.

### **2.14 Heavy Rain and Water Operations - All Climates**

- A. Perform maintenance in accordance with the appropriate climatic conditions.
- B. Always attempt to keep pistol dry.
- C. Always try to drain any water from barrel prior to firing. Dry the bore with a swab and cleaning rod.
- D. Lightly lube the bore and chamber. Generously lube internal and external surfaces of the pistol with CLP/LSA.

- E. In extreme or prolonged wet or saltwater conditions, cover serial number and proof mark on barrel and slide with a temporary protective coating. These are etched on through the permanent protective coating on the barrel and slide and therefore may corrode under these conditions.

## SECTION V - MALFUNCTIONS AND STOPPAGES

**2.15 Remedial Action** - Remedial Action is the action performed to remedy an unanticipated interruption of the pistol's operation and place the pistol back into operation.

### WARNING

**During remedial action, make certain the pistol is pointed in a safe direction at all times.**

- A. **Clear the pistol!**
- B. Attempt to lock slide.
- C. Remove magazine.
- D. Inspect chamber.
- E. Insert fresh magazine
- F. Release slide.
- G. Attempt to fire the pistol.

If the Mark 23 fails to fire, return the weapon to the HK Service Department for service.

### WARNING

**If a round is assembled without powder (a fault of the manufacturing process), the primer alone has enough power to propel the projectile into the bore. A projectile lodged in the bore may cause damage to the barrel and/or the pistol if another round is fired and could cause personal injury. This event is commonly called a "pop and no kick" or "squib load" and is characterized by a much reduced report and little or no movement of the slide. An alert operator should notice the occurrence of this event in time to avoid firing the next round.**

### Selection and Use of a Holster -

**Selection** - When selecting a carrying holster for the HK Mark 23, it is important to consider the following points:

1. The holster must not make contact with or actuate any of the operating controls. This includes the hammer, slide release, magazine release lever, and most importantly the safety lever and the

trigger. The design of the holster must also not actuate these controls when the pistol is carried in, drawn from, or returned to the holster.

2. The holster should not cause the slide to move (unlock) when the pistol is returned to the holster.
3. Accommodations must be provided in the holster for any accessories that might be present on the pistol.
4. Choose a holster designed for the Mark 23.

**Returning the Pistol to the Holster** - The HK Mark 23 must be made “safe” (or cleared) prior to returning it to the holster. The pistol is considered safe to return it to the holster when:

1. All fingers are off of the trigger and out of the trigger guard and;
2. The pistol is “clear” or;
3. The hammer is in the decocked (down) position or;
4. The safety lever is engaged in the safe position when the hammer is cocked.

**WARNING**

**The pistol must never be returned to the holster unless the above procedures have been followed or injury or death could occur.**

## CHAPTER 3 MAINTENANCE INSTRUCTIONS

### SECTION I - TOOLS & EQUIPMENT

#### NOTE

**The service life and performance of your HK Mark 23 is dependent upon the correct handling and proper care by the operator.**

**3.1 Operator Tools and Equipment Required.** At a minimum, you will require the following materials to maintain the Mark 23 pistol and its components:

- Cleaning rod with handle and eyelet
- Long handled nylon brush
- Bronze bristle bore brush (.45 caliber)
- Cotton swabs
- Solvent/bore cleaner/CLP
- Cleaning patches (.45 caliber)
- Rag

#### CAUTION

**Use safety goggles when using solvents and exercise care if using compressed air.**

### SECTION II - PREVENTATIVE MAINTENANCE (PM) SERVICE CHECKS & MAINTENANCE PROCEDURES

**3.2 General** - This PM Service section lists those required checks and services to be performed by personnel who operate the Mark 23 pistol. This section includes the services required to prepare the pistol for operation, to check the pistol during operation, and to ensure proper function after maintenance. Before performing any PM Service procedures, ensure that the Firearm Service Record has been updated with the correct round count and any PM Service procedures documented. If your equipment fails to operate, refer to the Troubleshooting Table in Section III.

#### WARNING

**Before starting an inspection procedure CLEAR THE PISTOL! Inspect the chamber to ensure that it is empty. Do not keep live ammunition near maintenance /work areas.**

### NOTE

Before starting any PM Service procedure ensure that the Firearm Service Record has been updated with the correct round count and any PM Service performed documented.

## 3.3 Disassembly (Field stripping)

### A. Pistol

1. **Clear the pistol!**
2. Depress slide release and allow slide to move forward.
3. If applicable, remove any mounted accessories.
4. Using the left hand, retract and hold the slide to the rear approximately 22 mm until the front end of the slide release is centered on the recess visible on the left side of the slide (See Figure 10).
5. With the right hand push the slide release into the recess on the right side of the frame, lift and completely remove the slide release from the left side of the frame.

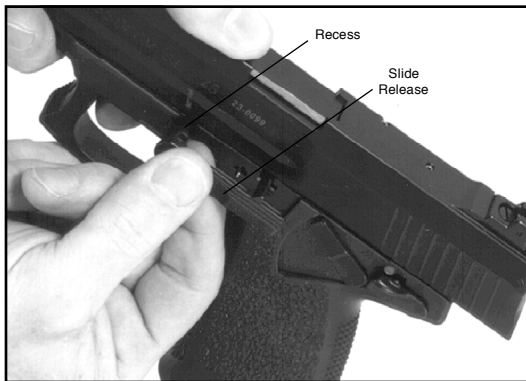

Figure 10  
Removing or Installing the Slide Release

### CAUTION

Hold the recoil/buffer spring assembly in place while removing the slide from the frame.

6. Remove the slide with barrel and captured recoil/buffer spring assembly off of the frame by sliding it forward.
7. Remove the captured recoil/buffer spring assembly from the barrel and slide by lifting up on the rear of the guide rod. The entire assembly can now be lifted out of the slide.
8. Lift the rear of the barrel by the locking block and withdraw it from the slide.

## B. Magazine

### 12-Round Law Enforcement Magazine

1. Using a blunt pointed instrument depress the locking detent protruding through the bottom of the magazine floor plate and **hold it there**.
2. Place a portion of either hand over the base of the magazine to control the release of the magazine spring and locking plate.
3. **Slowly** slide the floor plate forward off of the magazine housing.
4. Gradually allow the locking plate and magazine spring to expand out of the magazine housing.
5. Remove the locking plate, magazine spring and magazine follower from the magazine housing.

### 10-Round Civilian Magazine

1. Using a blunt pointed instrument depress the locking insert detente located in the floor plate **and hold it there**.
2. Place a portion of either hand over the base of the magazine to control the release of the magazine spring and locking insert.
3. With the locking detente still depressed, squeeze the floor plate locking tabs located on the right and left sides of the magazine.
4. **Gradually** allow the locking insert and magazine spring to expand out of the magazine housing.
5. Remove the locking insert, magazine spring and magazine follower from the magazine housing.

#### CAUTION

**Beware of the spring tension exerted by the magazine spring while removing and installing the magazine floor plate. Keep the base of the magazine pointed in a safe direction (away from face and eyes) during disassembly and assembly.**

## CAUTION

Operator disassembly of the Mark 23 pistol is now complete. Only trained HK Service Department personnel may disassemble the weapon further.

### 3.4 Reassembly (From field strip)

#### A. Magazine

#### 12-Round Law Enforcement Magazine

1. Place the magazine follower onto the end of the magazine spring having the loop at the end of the wire on the left side of the follower.
2. Insert the follower and the magazine spring into the magazine housing.
3. Place the locking plate onto the protruding end of the magazine spring so that the locking detent is visible (see Figure 11A).
4. Push the locking plate down into the magazine housing against the pressure of the magazine spring and **hold it there**.
5. Slide the floor plate over the base of the magazine housing and locking plate from front to rear making sure that:
  - a. The floor plate engages the tabs located on

the left and right sides of the magazine housing.

- b. The floor plate is fully seated on the magazine housing.
- c. The locking detent fits within the hole provided in the floor plate.
- d. Check the magazine for proper assembly by insuring that the follower slides up and down freely within the magazine housing and with spring tension. Also check that the magazine follower rises within the housing to be nearly flush against the bottom of the magazine lips.

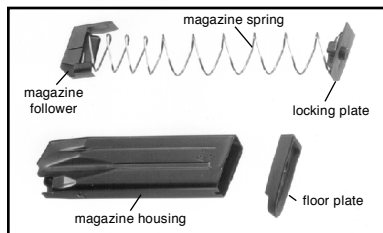

Figure 11A Assembly of Magazine Follower & Spring (12-Round Law Enforcement Magazine)



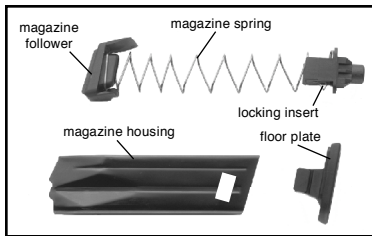

Figure 11B 10-Round Civilian Magazine (Disassembled)

### 10-Round Civilian Magazine (see Figure 11B)

1. Place the magazine follower onto the magazine spring with the end of the spring positioned on the left of the follower.
2. Insert the follower and magazine spring into the magazine housing.
3. Place the locking insert (on 10-round magazines) onto the protruding end of the magazine spring so that the rounded corners face towards the front of the magazine.

4. Push the locking plate down into the magazine housing against the pressure of the magazine spring **and hold it there.**
5. Push the floor plate up onto the base of the magazine housing until the locking tabs engage in the sides of the housing. Check to see if the locking tabs on the floor plate are securely locked into the housing and the locking detente on the locking plate fits within the hole in the floor plate.
6. Check the magazine for proper assembly by insuring that the follower slides up and down freely within the magazine housing and with spring tension. Also check that the magazine follower rises within the magazine housing to be nearly flush against the bottom of the magazine lips.

### B. Pistol

1. Insert the muzzle of the barrel through the large hole located in the front of the slide.
2. Drop the barrel down into the slide and push it forward until the O-ring engages the slide, the locking block fits within the ejection port, and the angled locking surface of the locking block are visible along the bottom of the slide. The

- O-ring will now hold the muzzle tight in the front of the slide.
3. Install the captured recoil/buffer spring assembly into the slide so that the front of the recoil spring guide rod engages in the smaller hole located in the front of the slide.
  4. Align the opposing angled locking surfaces of the recoil spring guide rod with those located on the bottom of the barrel locking block.
  5. Push the rear of the recoil/buffer spring assembly forward enough so that the recoil spring retainer can be engaged on the shelf provided on the front of the barrel locking block (see Figure 12).
  6. Hold the slide in the right hand with the thumb holding the rear end of the recoil/buffer spring assembly in place on the slide (see Figure 13).
  7. Hold the frame in the left hand. Position the rear of the slide above the front edge of the frame.
  8. Draw the slide back onto the frame so that the rails of the locking insert and guiding part slide within the grooves in the slide.
  9. Retract the slide to the point where the recess in the left side of the slide is centered on the hole where the axle of the slide release will go.

10. Hold the slide in this position and insert the slide release from the left to right into the frame until it is flush with the side of the frame and locks in place.

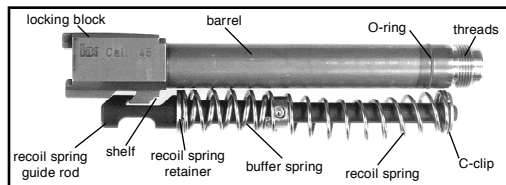

Figure 12 Proper Position for the Captured Recoil/Buffer Spring Assembly on the Barrel Locking Block

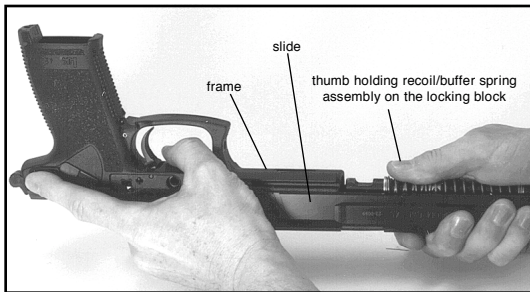

Figure 13 Correct Position for Holding Slide for Reassembly

#### NOTE

Operator reassembly of the Mark 23 pistol is now complete, but not finished without a safety/function check.

### 3.5 Safety/Function Check

A. A safety/function check should be performed anytime the pistol is reassembled. This quick

check indicates whether or not the pistol was properly assembled and with all the components. A properly executed safety/function check can also reveal many of the more obvious malfunctions that could occur between the interactive components of the pistol.

- B. **Always** clear the pistol before performing a safety/function check! ***Don't assume the pistol is clear!***
1. **Clear the pistol!**
  2. Actuate the slide and the operating controls to insure that:
    - a. **Magazine and catch** - the magazine is held securely in place by the magazine catch and that it drops free of the frame when the catch is depressed.
    - b. **Slide** - the slide moves freely and without binding on the frame (with and without a magazine installed).
    - c. **Barrel** - the barrel locking block does lock fully into battery within the ejection port of the slide as the slide is closed.
    - d. **Slide Release** -
      - 1) The slide release does hold the slide open when retracted while:

- a) an empty magazine is in place.
- b) the slide release is engaged (pressed upwards).

2) The slide release does permit the slide to snap forward when:

- a) the slide release is depressed.
- b) the slide is retracted without a magazine installed.

3) The slide release does rebound with spring pressure.

3. Perform the following safety checks:

**a. Safety Lever Test.**

1) With the pistol unloaded and hammer down (uncocked) attempt to press the safety lever upward into the safe position. The safety lever should not engage. If the safety lever engages, return the pistol to the HK Service Department for service.

2) With the pistol unloaded, the hammer cocked, move the safety lever several times from the “safe” to “fire” position. If the safety lever does not have a pro-

nounced stop when moved from “safe” to “fire” position and back, return the pistol to the HK Service Department for service.

3) With the pistol unloaded, cock the hammer and press the safety lever upward into the safe position. Grasp the pistol in the shooting position and squeeze the trigger three or four times. If the hammer falls, return the pistol to the HK Service Department for service.

**b. Decocking Lever Test.**

1) With the pistol unloaded, cock the hammer and depress the decocking lever. If the hammer does not fall or the decocking lever does not rebound (upward into its normal position) with spring pressure, return the pistol to the HK Service Department for service.

2) With the pistol unloaded, cock the hammer and press the safety lever upward into the safe position. Attempt to depress the decocking lever three or four

times. If the hammer falls, return the pistol to the HK Service Department for service.

#### **c. Decocked (hammer down) Test.**

##### **NOTE**

**On the Mark 23 pistol when decocked (hammer down), the sear is engaged with the hammer at a rebounded stop position not touching the rear of the firing pin.**

- 1) With the pistol unloaded, squeeze the trigger allowing the hammer to cycle in the double action mode. After the hammer drops, retain pressure on the trigger. With the non-firing hand apply pressure with your finger tips on the rear of the hammer. The hammer should move forward toward the firing pin. Release pressure on the trigger while still retaining pressure with fingers on hammer. Release pressure on hammer. If the hammer fails to spring back into the stop position, return the pistol to the HK Service Department for service.

- 2) With the pistol unloaded, hammer uncocked, trigger forward, apply pressure to the hammer with your finger tips. If the hammer moves forward to the firing pin, return the pistol to the HK Service Department for service.

#### **d. Disconnecter and Trigger Test.**

- 1) With the pistol unloaded, cock the hammer, push the slide rearward approximately 3/16 inches (2mm) and hold in that position while squeezing the trigger. If the hammer falls, return the pistol to the HK Service Department for service.
- 2) With the pistol unloaded, pull the slide rearward until the slide stop will engage. Squeeze the trigger and release the slide forward simultaneously. If the hammer falls, return the pistol to the HK Service Department for service.

- 3) With the pistol unloaded, pull the slide rearward and engage the slide. Squeeze the trigger and release the slide forward simultaneously. Release pressure on the trigger. If the trigger does not return to its normal position, return the pistol to the HK Service Department for service. Squeeze the trigger and the hammer should fall. If the hammer does not fall, return the pistol to the HK Service Department for service.
- 4) With the pistol unloaded and the trigger forward, apply thumb pressure to the cocked hammer. If the hammer lowers solely as a result of thumb pressure, return the pistol to the HK Service Department for service.

### 3.6 Function Firing

If any corrective action was accomplished, the pistol shall be function fired a full magazine prior to being cleaned and returned to service use.

### 3.7 Cleaning - performed after each firing, or every twelve (12) months, or after any exposure to extreme environmental conditions such as salt, fog, sand, dust, mud, water, etc.

#### A. Normal Cleaning -

##### 1. Clear the pistol!

2. Disassemble the pistol into the major assembly groups.

##### a. Slide -

- 1) Scrub all internal surfaces of the slide using the nylon brush moistened with solvent.
- 2) Remove all loose fouling from all surfaces of the slide using a rag and cotton swabs.

- ##### b. Recoil/buffer spring assembly - remove all visible fouling using solvent, a nylon brush, a rag, and cotton swabs.

##### c. Barrel with locking block -

- 1) Moisten the bronze bore brush with solvent and scrub the bore from chamber to muzzle at least six passes, back and forth. (Note: Repeat steps 1 and 2 until a cleaning patch can be pushed through the bore and remains clean.)

- 2) Remove the loose fouling using cleaning patches.
- 3) Scrub outside surfaces of barrel and locking block with the nylon brush moistened with solvent.
- 4) Scrub the threads of the barrel and O-ring with the nylon brush moistened with solvent.
- 5) Remove all loose fouling using a rag and cotton swabs.

d. **Frame** -

- 1) Scrub all internal surfaces where carbon fouling is visible using the nylon brush moistened with solvent. Concentrate on the area normally covered by the slide.
- 2) Using the rag and cotton swabs, remove all loose fouling from all areas of the frame.

e. **Magazine** -

- 1) The magazine is disassembled for cleaning.
- 2) Scrub the top of the magazine, concentrating on the follower and feed lips, using the nylon brush moistened with solvent.
- 3) Using the rag and cotton swabs, remove all loose fouling from all surfaces of the magazine.

**NOTE**

**All parts of the HK Mark 23 can be immersed in any cleaning solvent that it is safe to put your hands into. Gasoline and other motor fuels are not authorized cleaning solvents. Avoid cleaning the frame in an ultrasonic cleaner as this can remove the colored “safe” and “fire” dots.**

**3.8 Inspection**

During and after cleaning the operator should inspect the pistol and its components for any irregularities that may cause problems during its operation. If any potential deficiencies are noted, they should be corrected immediately and/or brought to the attention of the HK Service Department for service.

**A. Visually Inspect the Pistol and Magazine for:**

1. Damaged or missing parts
2. Improper assembly or function
3. Absence of free movement, where applicable
4. Absence of spring tension, where applicable

5. Unaccustomed looseness
6. Parts exhibiting signs of cracks, burrs, dents, or obvious signs of damage or stress
7. Presence of stops or tactile clicks in controls, where applicable
8. General overall cleanliness
9. Presence of proper lubrication
10. Presence of corrosion or degradation of surface finish
11. Rubber hammer spur for cracks or chips

#### **CAUTION**

**If the rubber hammer spur is badly cracked or chipped, drop safety could be degraded. Pistol should be returned to HK Service Department to replace hammer.**

### **3.9 Lubrication**

All metal surfaces of the Mark 23 pistol have a special surface treatment that resists all types of corrosion including corrosion resulting from exposure to salt water. However, this surface treatment does not reduce friction between parts, therefore, lubricant must be applied to the pistol.

Any type of high-quality, medium weight lubricant (oil or grease) specifically designed for use on firearms, such as “Break-Free” (C.L.P.), will work well on the Mark 23 pistol.

Do not use lubricants that boast of their ability to penetrate metal as these substances may deaden primers.

#### **A. Where and how much?**

**No Lube** - (surface is dry and not slippery to the touch)

- Plastic components

**Light Lube** - (finger run across surface yields little or no lube)

- Bore, chamber, and exterior of barrel
- All metal parts
- All internal parts in slide and frame
- Magazine housing and spring
- Recoil/buffer spring assembly
- Sights
- O-ring



**Medium Lube** - (finger run across surface yields some lube but lube does not run down surface when held in a vertical position)

- Barrel locking block
- Slide rails
- All operating controls
- Locking insert and guiding part
- Extractor

**Heavy Lube** - (Lube runs down surface when held in a vertical position)

**NOTE**

**No heavy lube is required on the Mark 23 pistol.**

Reapply lubrication periodically during firing as it burns off from the heat. Apply lubricant using a shaving brush, cotton swabs, patches, or rag. A spray bottle also works well using compressed air to circulate the lubricant into all parts and to remove the excess.

## SECTION III - ADJUSTMENT OF SIGHTS

### Description -

1. The mechanical sights supplied with the Mark 23 pistol are comprised of a fixed front sight post combined with a rear sight with u-shaped notch of a conventional configuration. Both front and rear sights are held in place on the slide within a standard dovetail groove. The rear sight is also secured with a retaining screw and is adjustable for windage and elevation.
2. Both front and rear sights contain white circles (or cylindrical tritium capsules) that appear as dots to the operator. One dot is positioned on either side of the rear sight aperture and in the center of the front sight post. When the sights are properly aligned vertically and horizontally, so are these dots. Thus, the three dots can be used for rapid acquisition of the sights and proper sight alignment.

**Adjustment** - the battle sight zero of the Mark 23 pistol is easily adjusted by moving or replacing the rear sight.

### NOTE

**All windage and elevation adjustments are made using only the rear sight.**

1. **Windage adjustments** - to adjust the horizontal (left and right) impact of the projectile follow these steps below:
  - a. **Clear the Pistol!**
  - b. Note the index mark on the rear sight and its relationship to the index mark on the slide.
  - c. Loosen the rear sight retaining screw using a screw driver.
  - d. With a small hammer and brass or soft metal drift punch, drift the sight to the:
    - 1) LEFT to move the point of impact to the left.
    - 2) RIGHT to move the point of impact to the right.
    - 3) The amount of movement will depend on the individual shooter and the ammunition used.

## NOTE

**Always strike the sight on the sight base, not on the sight blades.**

- e. Retighten the rear sight retaining screw.
- f. Confirm your battlesight zero by firing the pistol again.

2. **Elevation Adjustments** -To adjust the vertical (up and down) impact of the projectile follow these steps below:

- a. **Clear the pistol!**
- b. Determine the amount of vertical change, in inches, that is required at 25 meters. Note the index mark on the rear sight and its relationship to the index mark on the slide.
- c. Loosen and remove the rear sight retaining screw using a screw driver.
- d. With a small hammer and brass or soft metal drift punch, drift the sight completely out of either side of the dovetail groove.
- e. Note the marking on the bottom of the rear sight. (The standard sight is unmarked),
- f. Select a higher or lower rear sight from

Figure 14.

- g. Using the brass or soft metal punch and hammer, install the new sight into the dovetail groove.
- h. Align the index marks of the rear sight and slide as noted in step b above.
- i. Reinstall and tighten the rear sight retaining screw.
- j. Confirm your battle sight zero by firing the pistol again.

3. **Rear Sight Selection** - The rear sight is marked with -6, -4, -2, unmarked, +2, +4, or +6. This marking represents the amount of vertical change, in inches, that occurs when that sight is exchanged with the sight originally installed in the pistol.

- 1) To RAISE the point of impact, install a higher rear sight.
- 2) To LOWER the point of impact, install a lower sight.

**Example:** The pistol is shooting 4 inches high at 25 meters. We want the pistol to shoot dead-on (point of aim, point of impact). The rear sight

removed from the pistol is unmarked (standard).

- 1) Figure 25 shows that the rear sight marked -4 would lower the point of impact two increments, or a total of 4 inches, from the standard unmarked rear sight removed from the pistol.
  - 2) The -4 sight would be the correct one to install. Obtain the exchangeable rear sight from the kit delivered with the pistols.

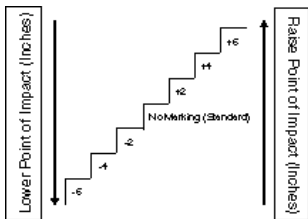

Figure 14

### C. Zeroing

1. The battlesight zero of the Mark 23 pistol is set by the manufacturer using +P 185 grain JHP ammunition. The pistol is fired from a machine rest at a target positioned 25 meters from the

pistol. The pistol is zeroed point of aim, point of impact (POA/POI). This means the impact of the projectile on target will coincide with the point of aim of the sights at 25 meters.

2. Each individual operator of the Mark 23 pistol can battlesight zero their pistol to their unique shooting style by adjusting the sights in accordance with the procedures in subparagraphs 1 - 3 above.

## SECTION IV - TROUBLESHOOTING PROCEDURES

### 3.11 Operator Troubleshooting Procedures

PROBLEM	SYMPTOM/CAUSE	REMEDY
1. Round does not feed	Fouled magazine or pistol	Clean and lube pistol and magazine
	Improperly assembled	Assemble correctly
	Incorrect loading procedure used	Load pistol in accordance with instructions in operator's manual
	Unserviceable magazine	Replace magazine
2. Round does not chamber	Dirty or damaged magazine	Clean and lube or replace magazine
	Obstruction present in chamber and/or bore	Remove obstruction, clean and lube chamber/bore
	Bent or damaged recoil spring, buffer spring, or guide rod. Buffer spring retainer roll pin drift. *	Return pistol to the HK Service Department for service

**\* NOTE**

**Always inspect the buffer spring retainer roll pin for drift. If not firmly seated and centered in the guide rod, return to the HK Service Department for replacement.**

PROBLEM	SYMPTOM/CAUSE	REMEDY
3. Slide does not lock fully forward	Fouled barrel locking block or slide	Clean and lube barrel locking block and slide
	Dry component parts or pistol	Lubricate pistol in accordance with instructions in operator's manual
	Damaged or burred slide, barrel locking block, or recoil/buffer spring assembly. Buffer spring retainer roll pin drift. *	Return pistol to the HK Service Department for service
4. Pistol does not fire	Faulty ammunition	Replace ammunition
	Little or no sign of firing pin strike (indent) on primer	Return pistol to the HK Service Department for service
5. Slide does not unlock	Faulty ammunition, determined by short recoil	Check bore for obstruction and replace ammunition
	Check for broken or damaged slide, barrel locking block or recoil/buffer spring assembly. Buffer spring retainer roll pin drift. *	Return pistol to the HK Service Department for service

PROBLEM	SYMPTOM/CAUSE	REMEDY
6. Cartridge does not extract	Fouled chamber	Clean and lube
	Ruptured cartridge case in chamber	Remove ruptured case, clean and lube chamber
	Fouled or corroded ammunition	Replace ammunition
	Pitted or damaged chamber	Return pistol to the HK Service Department for service
	Broken or damaged extractor or extractor spring	Return pistol to the HK Service Department for service
7. Operating controls do not function as described in operator's manual	Damaged or improperly assembled component parts	Return pistol to the HK Service Department for service
8. Accuracy degradation	Damaged or missing O-ring	Replace O-ring

### 3.12 Parts Listing for Mark 23 Pistol

Position No.	Item Description	Part No.	Position No.	Item Description	Part No.
1	extractor	215707	35	roll pin (right safety lever)	986430
2	extractor spring	215708	36	right safety lever	215744
3	rear sight retaining screw	215711	37	sear block	215754
4	rear sight, 6.3mm standard (unmarked)	215770	38	decocking lockout	215745
	rear sight, 5.5mm (-4)*	215767	39	hammer axle	215738
	rear sight, 5.9mm (-2)*	215768	40	hammer, complete	215772
	rear sight, 6.7mm (+2)*	215771	41	hammer rebound spring	215739
	rear sight, 7.1mm (+4)*	215774	42	hammer strut	215740
	rear sight, 7.5mm (+6)*	215783	43	hammer strut spring	215741
5	front sight	215721	44	insert	215731
6	firing pin	215705	45	locking bolt	215732
7	firing pin spring	215706	46	frame	215976
8	firing pin block	215709	47	safety detent	215746
9	firing pin block spring	215710	48	safety detent spring	215747
10	firing pin retaining pin	986432	49	left safety lever	215769
11	extractor pin	986432	50	decocking lever	215766
12	slide	215667	51	magazine release pin	986432
13	barrel	215671	52	magazine release spring	215737
14	O-ring	986429	53	magazine release	215775
15	recoil spring guide rod	215724	54	slide release spring	215733
16	recoil spring retainer	215725	55	trigger	215735
17	buffer spring	215726	56	trigger pin	215736
18	dual roll pin (buffer spring retainer)	986433	57	slide release lever, complete	215763
19	buffer spring retainer	215727	58	magazine housing (12-rd magazine)	215778
20	spring ring	929191	58A	magazine housing (10-rd magazine)*	215672
21	washer	215728	59	follower (10 & 12-rd magazine)	215779
22	recoil spring	215729	60	locking plate (12-rd magazine)	215781
23	trigger bar, complete	215760	60A	locking plate (10-rd magazine)*	214853
24	trigger bar spring	215734	61	floor plate (12-rd magazine)	215780
25	c-clip (decocker)	927062	61A	floor plate (10-rd magazine)*	215673
26	decocking spring	214743	62	magazine spring (12-rd magazine)	215782
27	decocker	215742	62A	magazine spring (10-rd magazine)*	214821
28	roll pin (ejector)	986431	63	locking insert (molded into frame)	
29	ejector	215752	64	trigger guard insert (molded into frame)	
30	sear	215748	65	guiding part (molded into frame)	
31	sear spring	215749		magazine (12-rd with LE markings), complete*	215668
32	sear actuator	215750		magazine (10-rd), complete*	215670
33	disconnecter	215751			
34	sear axle	215753		*not pictured	





## CHAPTER 4- AMMUNITION

The Mark 23 pistol was designed to operate best using two types of .45 ACP caliber ammunition. They are:

- A. M1911 230 grain Ball
- B. Commercially Manufactured 185 grain +P Jacketed Hollow Point (JHP)

### WARNING

**The use of incorrect ammunition in the pistol could result in damage to the pistol and/or injury to the operator or bystanders**

### DO NOT USE

- Reloaded, remanufactured, or military surplus (foreign or outdated) ammunition
- Ammunition loaded in aluminum cartridge cases
- Cracked, split, dirty or corroded cases
- Ammunition assembled with corrosive primer and/or propellant
- Ammunition assembled with projectile damaged or pushed into cartridge case past crimp
- Ammunition exposed to oil, grease, water, or direct sunlight. Remove contaminants if

possible before use and cool down ammunition exposed to direct sunlight or heat. (Exposure to sources of heat could raise the chamber pressure of the cartridge above safe limits).

### WARNING

**Heckler & Koch specifically disclaims any responsibilities for any damage or injury that should occur because of, or as a result of, the use of faulty, remanufactured, or reloaded (hand loaded) ammunition, or of cartridges other than those for which the pistol was originally chambered for.**

### NOTE

**If after reviewing this manual you still have questions, please contact your HK dealer or telephone the Heckler & Koch Customer Service Department. Please address any suggested changes or improvements concerning this manual to HK's Creative Services Department.**

## CHAPTER 5- LOCKOUT

Mark 23 pistols produced after October 1999 are equipped with a patented HK Lock-Out™ Device. This component replaces the lanyard loop insert in the frame and when engaged locks the handgun's action by blocking any movement of the trigger, the hammer, and the slide. The handgun is locked and can not fire until unlocked. The Lock-Out control plate is accessible through the pistol's magazine well (see Fig. 22).

**WARNING: Always point the pistol in a safe direction when locking or unlocking the Lock-Out Device. The pistol should be unloaded and “clear” before locking the Lock-Out Device**

**CAUTION: In USP pistols fitted with the Law Enforcement Modification (LEM), the pistol must first be unloaded, “cleared”, and dry fired to release the compressed hammer spring before the Lock-Out Device can be locked.**



Figure 22

Turn the key clockwise to lock the action

Use the two pronged key supplied with the pistol to lock or unlock the pistol as desired. When the holes on the Lock-Out Device are horizontally positioned the pistol is locked and can not be fired (see figure 23).



Figure 23

Locked position

When the holes on the Lock-Out Device are vertically positioned the pistol is unlocked and can be fired (see figure 24).

For more information contact HK Customer Service Representative at Heckler & Koch.

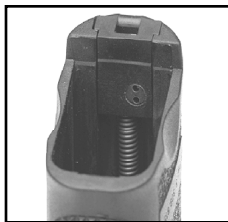

Figure 24 Unlocked/fire position

**WARNING: The HK Lock-Out Device is not a substitute for safe gun handling practices. Never point the muzzle of the pistol in an unsafe direction (at yourself or others). When the Lock-Out Device is placed in the locked position the slide is locked in the closed position and can not be moved! Forcing the slide rearward while the gun is in this locked position will damage the Mark 23.**









**In a world of compromise, some don't.**

---

**Heckler & Koch, Inc.  
21480 Pacific Blvd.  
Sterling, Virginia 20166-8903  
United States of America  
Tel. (703) 450-1900**

**Heckler & Koch GmbH  
D-78722 Oberndorf/Neckar  
Postfach 1329  
Germany  
Tel. 011/49/7423/79-1**