AT Commands
For GSM/GPRS Wireless
Modems

Reference Guide

AT Commands for GSM/GPRS Wireless Modems

Reference Guide

Products: MTCBA-G-F1/F2, MTMMC-G-F1/F2, and MTSMC-G-F1/F2
PN S000293C, Revision C

Copyright

This publication may not be reproduced, in whole or in part, without prior expressed written permission from Multi-Tech Systems, Inc. All rights reserved. Copyright © 2003, by Multi-Tech Systems, Inc.

Multi-Tech Systems, Inc. makes no representations or warranties with respect to the contents hereof and specifically disclaims any implied warranties of merchantability or fitness for any particular purpose. Furthermore, Multi-Tech Systems, Inc. reserves the right to revise this publication and to make changes from time to time in the content hereof without obligation of Multi-Tech Systems, Inc. to notify any person or organization of such revisions or changes.

Revisions

Revision Level	Date	Description
A	07/15/03	Initial release.
B	03/08/04	Add Values to each command. Add new commands.
C	09/28/04	Change page 19 data/fax call to ATD<nb> ; and voice call to ATD<nb> Change page 93 Autobauding is supported (operating from 2400 to 115200)

Trademarks

The Multi-Tech logo is a trademark of Multi-Tech Systems, Inc.

World Headquarters

Multi-Tech Systems, Inc.
 2205 Woodale Drive
 Mounds View, Minnesota 55112
 Phone: 763-785-3500 or 800-328-9717
 Fax: 763-785-9874

Technical Support

Country	By Email	By Phone
France:	support@multitech.fr	(33) 1-64 61 09 81
India:	support@multitechindia.com	91 (124) 6340778
U.K.:	support@multitech.co.uk	(44) 118 959 7774
U.S. and Canada:	support@multitech.com	(800) 972-2439
Rest of the World:	support@multitech.com	(763) 717-5863
Internet Address:	http://www.multitech.com	

Contents

Chapter 1 - Introduction	10
Scope of This Document.....	10
Related Documents	10
Definitions	10
Chapter 2 - AT command Features.....	11
Line Settings	11
Command Line.....	11
Information Responses and Result Codes	11
Chapter 3 - General behaviors	12
SIM Card Insertion and Removal Procedures	12
Background Initialization	12
Chapter 4 - General AT Commands.....	13
Manufacturer Identification +CGMI	13
Request Model Identification +CGMM	13
Request Revision Identification +CGMR	13
Product Serial Number +CGSN	14
Select TE Character Set +CSCS	14
Phonebook Character Set +WPCS.....	14
Request IMSI +CIMI.....	15
Card Identification +CCID	15
Capabilities List +GCAP.....	15
Repeat Last Command A/.....	15
Power Off +CPOF	15
Set Phone Functionality +CFUN	16
Phone Activity Status +CPAS	16
Report Mobile Equipment Errors +CMEE	17
Keypad Control +CKPD	17
Clock Management +CCLK	17
Alarm Management +CALA	18
Chapter 5 – AT Call Control commands	19
Dial Command D.....	19
Hang-Up command H	20
Answer a Call A.....	21
Remote Disconnection.....	21
Extended Error Report +CEER.....	21
DTMF Signals +VTD, +VTS.....	22
Redial Last Telephone Number DL.....	22
Automatic Dialing with DTR %D	23
Automatic Answer S0.....	23
Incoming Call Bearer +CICB.....	24
Single Numbering Scheme +CSNS	24
Gain Control +VGR, +VGT	25
Microphone Mute Control +CMUT	26
Speaker & Microphone Selection +SPEAKER	26

Echo Cancellation +ECHO.....	27
SideTone Modification +SIDET.....	29
Initialize Voice Parameters +VIP	29
Chapter 6 - Network service commands.....	30
Signal Quality +CSQ.....	30
Operator Selection +COPS.....	31
Network Registration +CREG.....	33
Read Operator Name +WOPN	34
Selection of Preferred PLMN List +CPLS.....	34
Preferred Operator List +CPOL	35
Read Operator Name +COPN.....	37
Chapter 7 - Security commands	38
Enter PIN +CPIN.....	38
Enter PIN2 +CPIN2.....	40
PIN Remaining Attempt Number +CPINC	40
Facility Lock +CLCK.....	41
Change Password +CPWD.....	42
Chapter 8 - Phonebook commands.....	43
Select Phonebook Memory Storage +CPBS	43
Read Phonebook Entries +CPBR.....	44
Find Phonebook Entries +CPBF.....	44
Write Phonebook Entry +CPBW	45
Phonebook Phone Search +CPBP	46
Move Action in Phonebook +CPBN.....	46
Subscriber Number +CNUM	47
Avoid Phonebook Initialization +WAIP.....	48
Delete Calls Phonebook +WDCP	48
Set Voice Mail Number +CSVM.....	49
Chapter 9 - Short Messages Commands	50
Parameters Definition	50
Select Message Service +CSMS.....	51
New Message Acknowledgement +CNMA.....	51
Preferred Message Storage +CPMS	53
Preferred Message Format +CMGF	54
Save Settings +CSAS.....	54
Restore Settings +CRES	55
Show Text Mode Parameters +CSDH.....	55
New Message Indication +CNMI	56
Read Message +CMGR.....	57
List Message +CMGL	58
Send Message +CMGS	59
Write Message to Memory +CMGW	59
Send Message from Storage +CMSS.....	60
Set Text Mode Parameters +CSMP	60
Delete Message +CMGD.....	61
Service Center Address +CSCA.....	62

Select Cell Broadcast Message Types +CSCB.....	62
Cell Broadcast Message Identifiers +WCBM.....	63
Message Status Modification +WMSC.....	63
Message Overwriting +WMGO.....	64
Unchange SMS Status +WUSS.....	65
Chapter 10 – Supplementary Services Commands.....	66
Call Forwarding +CCFC.....	66
Call Barring +CLCK.....	67
Modify SS Password +CPWD.....	68
Call Waiting +CCWA.....	68
Calling Line Identification Restriction +CLIR.....	69
Calling Line Identification Presentation +CLIP.....	70
Connected Line Identification Presentation +COLP.....	71
Advice of Charge +CAOC.....	72
Accumulated Call Meter +CACM.....	72
Accumulated Call Meter Maximum +CMM.....	73
Price Per Unit and Currency Table +CPUC.....	73
Call Related Supplementary Services +CHLD.....	74
List Current Calls +CLCC.....	75
Supplementary Service Notifications +CSSN.....	76
Unstructured Supplementary Service Data +CUSD.....	77
Closed User Group +CCUG.....	78
Chapter 11 - Data Commands.....	79
Using AT Commands During a Data Connection.....	79
Bearer Type Selection +CBST.....	80
Select Mode +FCLASS.....	81
Service Reporting Control +CR.....	81
Cellular Result Codes +CRC.....	82
DTE-DCE Local Rate Reporting +ILRR.....	82
Radio Link Protocol Parameters +CRLP.....	83
Other Radio Link Parameters +DOPT.....	83
Select Data Compression %C.....	84
V42bis Data Compression +DS.....	84
V42bis Data Compression Report +DR.....	85
Select Data Error Correcting Mode \N.....	85
Chapter 12 - Fax Commands.....	86
Transmit speed +FTM.....	86
Receive Speed +FRM.....	86
HDLC Transmit Speed +FTH.....	86
HDLC Receive Speed +FRH.....	87
Stop Transmission and Wait +FTS.....	87
Receive Silence +FRS.....	87
Setting Up the PC Fax Application:.....	87
Chapter 13 - Fax Class 2 Commands.....	88
Transmit Data +FDT.....	88
Receive Data +FDR.....	88

Transmit Page Punctuation +FET	88
Page Transfer Status Parameters +FPTS	88
Terminate Session +FK	89
Page Transfer Bit Order +FBOR.....	89
Buffer Size Report +FBUF	89
Copy Quality Checking +FCQ.....	89
Capability to Receive +FCR.....	89
Current Sessions Parameters +FDIS	90
DCE Capabilities Parameters +FDCC.....	91
Local ID String +FLID.....	91
Page Transfer Timeout Parameter +FPHCTO	91
Fax Class 2 Indication Messages	92
Chapter 14 – V.24 and V.25 commands	93
Fixed DTE Rate +IPR	93
DTE-DCE Character Framing +ICF	94
DTE-DCE Local Flow Control +IFC	95
Set DCD Signal &C.....	95
Set DTR Signal &D	96
Set DSR Signal &S	96
Back to Online Mode O.....	96
Result Code Suppression Q	97
DCE Response Format V	97
Default Configuration Z.....	97
Save Configuration &W.....	97
Auto-Tests &T.....	98
Echo E.....	98
Restore Factory Settings &F.....	98
Display Configuration &V.....	99
Request Identification Information I	99
Multiplexing Mode +WMUX.....	100
Chapter 15 - Specific AT commands.....	101
Cell Environment Description +CCED	101
General Indications +WIND	103
Analog Digital Converter Measurements +ADC	104
Mobile Equipment Event Reporting +CMER.....	105
Indicator Control +CIND.....	106
Mobile Equipment Control Mode +CMEC.....	107
Read Language Preference +WLPR	107
Write Language Preference +WLPW.....	108
Read GPIO Value +WIOR	108
Write GPIO Value +WIOW.....	109
Input/Output Management +WIOM.....	109
Abort Command +WAC	110
Play Tone +WTONE	110
Play DTMF Tone +WDTMF	111
Downloading +WDWL.....	111

Voice Rate +WVR	112
Data Rate +WDR	112
Select Voice Gain +WSVG	113
Status Request +WSTR.....	113
Scan +WSCAN	114
Ring Indicator Mode +WRIM.....	114
32kHz Power Down Mode +W32K	115
Change Default Melody +WCDM.....	115
Custom Character Set +WCCS	116
Lock +WLCK	117
CPHS Command +CPHS	118
Unsolicited Result: Voice Mail Indicator +WVMI.....	120
Unsolicited Result: Diverted Call Indicator +WDCI.....	120
Network Operator Name +WNON	121
CPHS Information +WCPI.....	121
Customer Service Profile +WCSP	122
Customer Storage Mirror +WMIR	122
Change Default Player +WCDP.....	122
CPHS Mail Box Number +WMBN.....	123
Alternate Line Service +WALS	124
Open AT Control Command +WOPEN.....	124
Reset +WRST	125
Set Standard Tone +WSST	126
Hang-up +WATH.....	127
Chapter 16 - SIM ToolKit.....	128
Overview of SIM Application ToolKit.....	128
Messages Exchanged During a SIM ToolKit Operation	130
SIM Toolkit Commands Section.....	131
SIM ToolKit Set Facilities +STSF.....	131
SIM ToolKit Indication +STIN.....	133
SIM ToolKit Get Information +STGI.....	134
Unsolicited Result: SIM ToolKit Control Response +STCR.....	137
SIM ToolKit Give Response +STGR.....	137
Chapter 17 - GPRS commands	140
Define PDP Context +CGDCONT	140
Quality of Service Profile Requested +CGQREQ.....	142
Quality of Service Profile Minimum Acceptable +CGQMIN	144
GPRS Attach or Detach +CGATT.....	145
PDP Context Activate or Deactivate +CGACT	146
Enter Data State +CGDATA	147
GPRS Mobile Station Class +CGCLASS.....	148
Select Service for MO SMS Messages +CGSMS	149
GPRS Event Reporting +CGEREP.....	150
GPRS Network Registration Status +CGREG.....	151
Request GPRS IP Service D	152
Network Requested PDP Context Activation.....	152

Automatic Response to a Network Request for PDP Context Activation +CGAUTO.....	153
Manual Response to a Network Request for PDP Context Activation +CGANS	154
Show PDP Address +CGPADDR	155
Cellular Result Codes +CRC	156
Service Reporting Control +CR	156
Extended Error Report +CEER.....	157
GPRS Parameters Customization +WGPRS.....	157
Full GPRS AT Command Examples	158
GPRS-Related Errors +CME ERROR	159
Specific GPRS Failure Cause for +CEER	159
Chapter 18 - Other AT commands	160
V.25ter Recommendation	160
GSM 07.05 Recommendation.....	160
GSM 07.07 Recommendation.....	160
Appendix A – Result Codes, Failure Causes, Other Tables	161
ME Error Result Code: +CME ERROR: <error>.....	161
Message Service Failure Result Code +CMS ERROR: <er>.....	162
Specific Error Result Codes.....	162
Failure Cause from GSM 04.08 Recommendation (+CEER)	163
Specific Failure Cause for +CEER.....	164
GSM 04.11 Annex E-2: Mobile Originating SM-Transfer.....	164
Unsolicited Result Codes.....	165
Final Result Codes.....	165
Intermediate Result Codes	165
Parameter Storage Mode.....	166
GSM Sequences List	168
Operator Names.....	170
Appendix B - Data Commands and Multiplexing, CPHS Information Field, and CSP Constants...178	
Data Commands and Multiplexing.....	178
CPHS Information Field	179
CSP Constants.....	180
Appendix C - AT Command Examples.....182	
Examples	182
Appendix D - ME SIM ToolKit Support.....186	
Appendix E - Structure of the Terminal Profile	188
Appendix F - Command Type and Next Action Indicator.....190	
Appendix G - Coding of Alpha fields in the SIM for UCS2.....191	
Appendix H - Specification of Power Down Control via RS232	192
Appendix I - Conditions for command execution and SIM dependence	193
General Commands.....	193
Call Control Commands.....	193
Network Service Commands	193
Security Commands.....	194
Phonebook Commands	194
Short Messages Commands.....	194
Supplementary Services Commands.....	194

Data Commands	195
Fax Commands.....	195
Class 2 Commands.....	195
V24-V25 Commands.....	195
Specific AT Commands	196
SIM ToolKit Commands	196
Index	197

CHAPTER 1 - INTRODUCTION

Scope of This Document

This document describes the AT-command based messages exchanged between an application and the Multi-Tech Systems, Inc. products in order to manage GSM-related events or services.

Related Documents

This interface specification is based on the following recommendations:

- [1] ETSI GSM 07.05: Digital cellular telecommunications system (Phase 2);
Use of DTE-DCE interface for Short Message Service (SMS) and Cell Broadcast Service (CBS)
- [2] ETSI GSM 07.07: Digital cellular telecommunications system (Phase 2);
AT command set for GSM Mobile Equipment (ME)
- [3] ITU-T Recommendation V.25 ter: Serial asynchronous automatic dialing and control
- [4] ETSI GSM 03.40: Digital cellular telecommunications system (Phase 2);
Technical implementation of the Short Message Service (SMS) Point-to-Point (PP)
- [5] ETSI GSM 03.38: Digital cellular telecommunications system (Phase 2);
Alphabets and language-specific information
- [6] ETSI GSM 04.80: Digital cellular telecommunications system (Phase 2);
Mobile radio interface layer 3, Supplementary service specification, Formats and coding

Definitions

The words, “Mobile Station” (MS) or “Mobile Equipment” (ME) are used for mobile terminals supporting GSM services.

A call from a GSM mobile station to the PSTN is called a “mobile originated call” (MOC) or “outgoing call”, and a call from a fixed network to a GSM mobile station is called a “mobile terminated call” (MTC) or “incoming call”.

In this document, the word “product” refers to any Multi-Tech product supporting the AT commands interface.

CHAPTER 2 - AT COMMAND FEATURES

Line Settings

A serial link handler is set with the following default values (factory settings): autobaud, 8 bits data, 1 stop bit, no parity, RTS/CTS flow control. Please use the +IPR, +IFC and +ICF commands to change these settings.

Command Line

Commands always start with AT (which means ATtention) and finish with a <CR> character.

Information Responses and Result Codes

Responses start and end with <CR><LF>, except for the ATV0 DCE response format and the ATQ1 (result code suppression) commands.

- If command syntax is incorrect, an **ERROR** string is returned.
- If command syntax is correct but with some incorrect parameters, the **+CME ERROR: <Err>** or **+CMS ERROR: <SmsErr>** strings are returned with different error codes.
- If the command line has been performed successfully, an **OK** string is returned.

In some cases, such as “AT+CPIN?” or (unsolicited) incoming events, the product does not return the **OK** string as a response.

In the following examples <CR> and <CR><LF> are intentionally omitted.

CHAPTER 3 - GENERAL BEHAVIORS

SIM Card Insertion and Removal Procedures

SIM card Insertion and Removal procedures are supported. There are software functions relying on positive reading of the hardware SIM detect pin. This pin state (open/closed) is permanently monitored.

When the SIM detect pin indicates that a card is present in the SIM connector, the product tries to set up a logical SIM session. The logical SIM session will be set up or not depending on whether the detected card is a SIM Card or not. The AT+CPIN? command delivers the following responses:

- If the SIM detect pin indicates “absent”, the response to AT+CPIN? is “+CME ERROR 10” (SIM not inserted).
- If the SIM detect pin indicates “present”, and the inserted Card is a SIM Card, the response to AT+CPIN? is “+CPIN: xxx” depending on SIM PIN state.
- If the SIM detect pin indicates “present”, and the inserted Card is not a SIM Card, the response to AT+CPIN? is CME ERROR 10.
- These last two states are not given immediately due to background initialization. Between the hardware SIM detect pin indicating “present” and the previous results the AT+CPIN? sends “+CME ERROR: 515” (Please wait, init in progress).

When the SIM detect pin indicates card absence, and if a SIM Card was previously inserted, an IMSI detach procedure is performed, all user data is removed from the product (Phonebooks, SMS etc.). The product then switches to **emergency mode**.

Background Initialization

After entering the PIN (Personal Identification Number), some SIM user data files are loaded into the product (Phonebooks, SMS status, etc.). Please be aware that it might take some time to read a large phonebook.

The AT+CPIN? command response comes just after the PIN is checked. After this response user data is loaded (in background). This means that some data may not be available just after PIN entry is confirmed by 'OK'. The reading of phonebooks will then be refused by “+CME ERROR: 515” or “+CMS ERROR: 515” meaning, “Please wait, service is not available, init in progress”.

This type of answer may be sent by the product at several points:

- When trying to execute another AT command before the previous one is completed (before response),
- When switching from ADN to FDN (or FDN to ADN) and trying to read the relevant phonebook immediately,
- When asking for +CPIN? status immediately after SIM insertion and before the product has determined if the inserted card is a valid SIM Card.

CHAPTER 4 - GENERAL AT COMMANDS

Manufacturer Identification +CGMI

Description: Displays the manufacturer identification.

Values: No parameters

Command syntax: AT+CGMI

Command	Possible responses
AT+CGMI	WAVECOM MODEM OK
<i>Note: Get manufacturer identification</i>	<i>Note: Command valid, Wavecom modem</i>

Request Model Identification +CGMM

Description: Displays the supported frequency bands. With multi-band products the response may be a combination of different bands.

Values: No parameters

Command syntax: AT+CGMM

Command	Possible responses
AT+CGMM <i>Note: Get hardware version</i>	MULTIBAND 900 E 1800 OK <i>Note: Multiband: GSM 900 MHz extended band and DCS 1800</i>
AT+CGMM <i>Note: Get hardware version</i>	MULTIBAND G850 1900 OK <i>Note: Multiband: GSM 850 and PCS</i>

Request Revision Identification +CGMR

Description: Displays the revised software version.

Values: No parameters

Syntax: AT+CGMR

Command	Possible responses
AT+CGMR <i>Note: Get software version</i>	640b09gg.Q2406A 1266500 070403 17:06 OK <i>Note: Software release 6.40b, generated on the 4th of July 2003</i>

Product Serial Number +CGSN

Description: Allows the user application to get the IMEI (International Mobile Equipment Identity, 15-digit number) of the product.

Values: No parameters

Syntax: AT+CGSN

Command	Possible responses
AT+CGSN	012345678901234 OK <i>Note: IMEI read from EEPROM</i>
AT+CGSN <i>Note: Get the IMEI</i>	+CME ERROR: 22 <i>Note: IMEI not found in EEPROM</i>

Select TE Character Set +CSCS

Description: Informs the ME which character set is used by the TE. The ME can convert each character of entered or displayed strings. This is used to send, read or write short messages. See also +WPCS for the phonebooks' character sets.

Values: <Character Set>

GSM GSM default alphabet.
 PCCP437 PC character set code page 437.
 CUSTOM User defined character set (cf. +WCCS command).
 HEX Hexadecimal mode. No character set used; the user can read or write hexadecimal values.

Default: GSM alphabet

Syntax: AT+CSCS=<Character Set>

Command	Possible responses
AT+CSCS="GSM" <i>Note: GSM default alphabet</i>	OK <i>Note: Command valid</i>
AT+CSCS="PCCP437" <i>Note: PC character set code</i>	OK <i>Note: Command valid</i>
AT+CSCS=? <i>Note: Get possible values</i>	+CSCS: ("GSM","PCCP437","CUSTOM","HEX") OK <i>Note: Possible values</i>

Phonebook Character Set +WPCS

Description: Informs the ME which character set is used by the TE for the phonebooks. The ME can convert each character of entered or displayed strings. This is used to read or write phonebook entries. See also +CSCS for the short messages character sets.

Values: <Character Set>

TRANSPARENT Transparent mode. The strings are displayed and entered as they are stored in SIM or in ME.
 CUSTOM User defined character set (cf. +WCCS command).
 HEX Hexadecimal mode. No character set used; the user can read or write hexadecimal values.

Syntax: AT+WPCS=<Character Set>

Command	Possible responses
AT+WPCS="TRANSPARENT" <i>Note: Transparent mode</i>	OK <i>Note: Command valid</i>
AT+WPCS="CUSTOM" <i>Note: Custom character set</i>	OK <i>Note: Command valid</i>
AT+WPCS=? <i>Note: Get possible values</i>	+WPCS: ("TRANSPARENT","HEX","CUSTOM") OK <i>Note: Possible values</i>

Request IMSI +CIMI

Description: Reads and identifies the IMSI (International Mobile Subscriber Identity) of the SIM card. The PIN may need to be entered before reading the IMSI.

Values: No parameters

Syntax: AT+CIMI

Command	Possible responses
AT+CIMI Note: Read the IMSI	208200120320598 OK Note: IMSI value (15 digits), starting with MCC (3 digits) / MNC (2 digits, 3 for PCS 1900)

Card Identification +CCID

Description: Orders the product to read the EF-CCID file on the SIM card.

Values: No parameters

Syntax: AT+CCID

Command	Possible responses
AT+CCID Note: Get card ID	+CCID: "123456789AB111213141" Note: EF-CCID is present, hexadecimal format
AT+CCID? Note: Get current value	+ CCID: "123456789AB111213141" Note: Same result as +CCID
AT+CCID= ? Note: Get possible value	OK Note: No parameter but this command is valid

Note: If there is no EF-CCID file present on the SIM, the +CCID answer will not be sent, but the OK message will be returned.

Capabilities List +GCAP

Description: Displays the complete list of capabilities.

Values: No parameters

Syntax: AT+GCAP

Command	Possible responses
AT+GCAP Note: Get capabilities list	+GCAP: +CGSM +FCLASS OK Note: Supports GSM and FAX commands

Repeat Last Command A/

Description: Repeats the previous command. Only the A/ command itself cannot be repeated.

Values: No parameters

Syntax: A/

Command	Possible responses
A/ Note: Repeat last command	

Power Off +CPOF

Description: Stops the GSM software stack as well as the hardware layer. The AT+CFUN=0 command is equivalent to +CPOF.

Values: No parameters

Syntax: AT+CPOF

Command	Possible responses
AT+CPOF Note: Stop GSM stack	OK Note: Command valid

Set Phone Functionality +CFUN

Description: Selects the mobile station's level of functionality. When the application wants to stop the product with a power off, or if the application wants to force the product to execute an IMSI DETACH procedure, then it must send: AT+CFUN=0 (equivalent to AT+CPOF). This command executes an IMSI DETACH and makes a backup copy of some internal parameters in SIM and in EEPROM. The SIM card cannot then be accessed. If the mobile equipment is not powered off by the application after this command has been sent, a re-start command (AT+CFUN=1) will have to issued to restart the whole GSM registration process. If the mobile equipment is turned off after this command, then a power on will automatically restart the whole GSM process. The AT+CFUN=1 command restarts the entire GSM stack and GSM functionality: a complete software reset is performed. All parameters are reset to their previous values if AT&W was not used. If you write entries in the phonebook (+CPBW) and then reset the product directly (AT+CFUN=1, with no previous AT+CFUN=0 command), some entries may not be written (the SIM task does not have enough time to write entries in the SIM card). In addition, the OK response will be sent at the last baud rate defined by the +IPR command. With the autobauding mode the response can be at a different baud rate, it is therefore preferable to save the defined baud rate with AT&W before directly sending the AT+CFUN=1 command.

Values: <functionality level>
 0: Set minimum functionality; IMSI detach procedure
 1: Set the full functionality mode with a complete software reset

Syntax: AT+CFUN=<functionality level>

Command	Possible responses
AT+CFUN? Note: Ask for current functionality level	+CFUN: 1 OK Note: Full functionality
AT+CFUN=0 Note: Set minimum functionality, IMSI detach procedure	OK Note: Command valid
AT+CFUN=1 Note: Set the full functionality mode with a complete software reset	OK Note: Command valid

Phone Activity Status +CPAS

Description: Returns the activity status of the mobile equipment.

Values: <pas>
 0 ready (allow commands from TA/TE)
 1 unavailable (does not allow commands)
 2 unknown
 3 ringing (ringer is active)
 4 call in progress
 5 asleep (low functionality)

Syntax: AT+CPAS

Command	Possible responses
AT+CPAS Note: Current activity status	+CPAS: <pas> OK

Report Mobile Equipment Errors +CMEE

Description: Disables or enables the use of the “+CME ERROR: <xxx>” or “+CMS ERROR:<xxx>” result code instead of simply “ERROR”. See Appendix A for +CME ERROR result codes description and +CMS ERROR result codes.

Values: <error reporting flag>
 0: Disable ME error reports; use only ERROR
 1: Enable +CME ERROR: <xxx> or +CMS ERROR: <xxx>

Syntax: AT+CMEE=<error reporting flag>

Command	Possible responses
AT+CMEE=0 Note: Disable ME error reports, use only ERROR	OK
AT+CMEE=1 Note: Enable +CME ERROR: <xxx> or +CMS ERROR: <xxx>	OK

Keypad Control +CKPD

Description: Emulates the ME keypad by sending each keystroke as a character in a <keys> string. The supported GSM sequences are listed in the Appendix A.

If emulation fails, a +CME ERROR: <err> is returned. If emulation succeeds, the result depends on the GSM sequence activated: <keys>: string of the following characters (0-9,*,#).

Note: In the case where the FDN phonebook is activated, the sequences concerning “call forwarding” are allowed only if the entire sequence is written in the FDN.

Values: <keys>

Keyboard sequence; sting of the following characters (0-9, *, #)

Syntax: AT+CKPD=<keys>

Command	Possible responses
AT+CKPD="*#21#" Note: Check every call forwarding status	+CCFC: 0,7
AT+CKPD="1234" Note: Sequence not allowed	+CME ERROR 3

Clock Management +CCLK

Description: Sets or gets the current date and time of the ME real-time clock.

Values: <date and time string>

String format for date/time is “yy/MM/dd,hh:mm:ss”

Note: Valid years are 98 (for 1998) to 97 (for 2097). The seconds field is not mandatory.

Default date/time is “98/01/01,00:00:00” (January 1st, 1998 / midnight).

Syntax: AT+CCLK=<date and time string>

Command	Possible responses
AT+CCLK="00/06/09,17:33:00" Note: set date to June 9 th , 2000, and time to 5:33pm	OK Note: Date/Time stored
AT+CCLK="00/13/13,12:00:00" Note: Incorrect month entered	+CME ERROR 3
AT+CCLK? Note: Get current date and time	+CCLK: "00/06/09,17:34:23" OK Note: current date is June 9 th , 2000 current time is 5:34:23 pm

Alarm Management +CALA

Description: Sets the alarm date/time in the ME. The maximum number of alarms is 16.

Values: <date and time string> String format for alarms: "yy/MM/dd,hh:mm:ss" (see +CCLK)
 Note: Seconds are taken into account.

<index> Offset in the alarm list, range 1 to 16

Syntax: AT+CALA=<date and time string> (set alarm)

AT+CALA="",<index> (delete alarm)

Command	Possible responses
AT+CALA="00/06/09,07:30" Note: set an alarm for June 9 th , 2000 at 7:30 am	OK Note: Alarm stored
AT+CALA="99/03/05,13:00:00" Note: set an alarm for March 5 th , 1999 at 1:00 pm	+CME ERROR 3 Note: Invalid alarm (date/time expired)
AT+CALA? Note: list all alarms	+CALA: "00/06/08,15:25:00",0 +CALA: "00/06/09,07:30:00",1 +CALA: "00/06/10,23:59:00",2 Note: three alarms are set (index 0, 1, 2)
	+CALA: "00/06/08,15:25:00",0 Note: an alarm occurs (index 0)
AT+CALA="",2 Note: delete alarm index 2	OK Note: Alarm index 2 deleted
AT+CALA? Note: list all alarms	+CALA: "00/06/09,07:30:00",1 Note: Only one alarm (index 1)

CHAPTER 5 – AT CALL CONTROL COMMANDS

Dial Command D

- Values:**
- <nb>** Destination phone number
 - <l>** Optional parameter <l> means “invocation” (restrict CLI presentation)
 - <i>** Means “suppression” (allow CLI presentation)
 - <mem>** Phonebook (one of SM, LD, MC, ME, RC, MT or SN). A default value can be selected by +CPBS command.
 - <index>** Call number at indicated offset from the phonebook selected by the +CPBS command.
 - <name>** Call number corresponding to given name from the phonebook selected by the +CPBS command.

Description: The ATD command sets a voice, data or fax call. As per GSM 02.30, the dial command also controls supplementary services.

For a **data** or a **fax call**, the application sends the following ASCII string to the product (the bearer must be previously selected with the +CBST command):

ATD<nb> where <nb> is the destination phone number;

For a **voice call**, the application sends the following ASCII string to the product: (the bearer may be selected previously, if not a default bearer is used).

ATD<nb>; where <nb> is the destination phone number.

Please note that for an **international number**, the local international prefix does not need to be set (usually 00) but does need to be replaced by the ‘+’ character.

Example: to set up a voice call to Multi-Tech offices from another country, the AT command is: **“ATD+17637853600;”**

Note that some countries may have specific numbering rules for their GSM handset numbering.

The response to the ATD command is one of the following:

Verbose result code	Numeric code (with ATV0 set)	Description
OK	0	if the call succeeds, for voice call only
CONNECT <speed>	10,11,12,13,14,15	if the call succeeds, for data calls only, <speed> takes the value negotiated by the product.
BUSY	7	If the called party is already in communication
NO ANSWER	8	If no hang up is detected after a fixed network time-out
NO CARRIER	3	Call setup failed or remote user release. Use the AT+CEER command to know the failure cause

Direct Dialing from a Phonebook (stored in the SIM card) can be performed with the following commands:

ATD> <index>; to call <index> from the selected phonebook (by the +CPBS command)

ATD> “BILL”; to call “BILL” from the selected phonebook

ATD> mem <index> (mem is **SM, LD, MC, ME, RC, MT** or **SN**, see +CPBS command) allows direct dialing from a phonebook number. Does not function with **ON** mem.

Syntax: ATD<nb>[<l>];
 ATD>[<mem>]<index>[<l>];
 ATD>[<mem>]<name>[<l>];

Command	Possible responses
AT+CPBS? Note: Which phonebook is selected ?	+CPBS:"SM",8,10 Note: ADN phonebook is selected, 8 locations are used and 10 locations are available
ATD>SM6; Note: Call index 6 from AND phonebook	OK Note: Call succeeds

When the FDN phonebook has been locked, only numbers beginning with the digits of FDN phonebook entries can be called. For example, if "014629" is entered in the FDN phonebook all the phone numbers beginning with these 6 digits can be called. The CLIR supplementary service subscription can be overridden for this call only.

"I" means "invocation" (restrict CLI presentation).

"i" means "suppression" (allow CLI presentation).

Control of CUG supplementary service information by "G" or "g" is allowed for this call only. The index and info values set with the +CCUG command are used. An outgoing call attempt could be refused if the AOC service is active and credit has expired (NO CARRIER). When trying to set up an outgoing call while there is an active call, the active call is first put on hold, then the call set up is carried out. As per GSM 02.30, GSM sequences may be controlled using dial commands. These sequences can contain "*", "#", but ";" is forbidden. If the sequence is not supported or fails, +CME ERROR: <err> is returned. In the case where the FDN phonebook is activated, the sequences concerning call forwarding are allowed only if there are written in the FDN.

Command	Possible responses
ATD*#21# Note: Check any call forwarding status	+CCFC: 0,7 Note: No call forwarding
ATD**61*+33146290800**25# Note: Register call forwarding on no reply, with no reply timer fixed at 25 s.	OK Note: done
ATD*2# Note: Bad sequence	+CME ERROR 3

Hang-Up command H

Description:

The ATH (or ATH0) command disconnects the remote user. In the case of multiple calls, all calls are released (active, on-hold and waiting calls). The specific ATH1 command has been appended to disconnect the current outgoing call, only in dialing or alerting state (ie. ATH1 can be used only after the ATD command, and before its terminal response (OK, NO CARRIER, ...). It can be useful in the case of multiple calls.

Values:

<n>

0: Ask for disconnection (default value)

1: Ask for outgoing call disconnection

Syntax: ATH<n>

Command	Possible responses
ATH Note: Ask for disconnection	OK Note: Every call, if any, is released
ATH1 Note: Ask for outgoing call disconnection	OK Note: Outgoing call, if any, is released

Answer a Call A

Description:

When the product receives a call, it sets the **RingInd** signal and sends the ASCII “**RING**” or “**+CRING: <type>**” string to the application (+CRING if the cellular result code +CRC is enabled). Then it waits for the application to accept the call with the ATA command.

Syntax: ATA

Command	Possible responses
	RING <i>Note: Incoming call</i>
ATA <i>Note: Answer to this incoming call</i>	OK <i>Note: Call accepted</i>
ATH <i>Note: Disconnect call</i>	OK <i>Note: Call disconnected</i>

Remote Disconnection

This message is used by the product to inform the application that an active call has been released by the remote user.

The product sends “**NO CARRIER**” to the application and sets the DCD signal.

In addition, for AOC, the product can release the call if credit has expired (release cause 68 with +CEER command).

Extended Error Report +CEER

Description:

This command gives the cause of call release when the last call set up (originating or answering) failed.

Values: No parameters

Syntax: AT+CEER

Command	Possible responses
ATD123456789; <i>Note: Outgoing voice call</i>	NO CARRIER <i>Note: Call setup failure</i>
AT+CEER <i>Note: Ask for reason of release</i>	+CEER: Error <xxx> OK <i>Note: <xxx>is the cause information element values from GSM recommendation 04.08 or specific Call accepted</i>

“NO CARRIER” indicates that the AT+CEER information is available for failure diagnosis.

DTMF Signals +VTD, +VTS

+VTD Description:

The product enables the user application to send DTMF tones over the GSM network. This command is used to define tone duration (the default value is 300ms). To define this duration, the application uses: AT+VTD=<n> where <n>*100 gives the duration in ms. If n < 4, tone duration is 300 ms.

+VTD Values:

<n> tone duration.

*100 is the duration in ms. If <n> < 4, tone duration is 300 ms; if n > 255, the value used is modulo 256.

Default value: 300 ms, that is <n> = 3.

+VTD Syntax: AT+VTD=<n>

Command	Possible responses
AT+VTD=6 <i>Note: To define 600 ms tone duration</i>	OK <i>Note: Command valid</i>
AT+VTD=0 <i>Note: To set the default value</i>	OK

+VTS Description:

The product enables the user application to send DTMF tones over the GSM network. This command enables tones to be transmitted only when there is an active call.

To transmit DTMF tones (only when there is an active call), the application uses:

AT+VTS=<Tone>

where <Tone> is in {0-9,*,#,A,B,C,D}

+VTS Values:

<Tone> DTMF tone to transmit. Tone is in {0-9, *, #, A, B, C, D}

+VTS Syntax: AT+VTS=<Tone>

Command	Possible responses
AT+VTS=A	OK <i>Note: Command valid</i>
AT+VTS=11 <i>Note: To set the default value</i>	+CME ERROR: 4 <i>Note: If the <Tone> is wrong</i>
AT+VTS=4	+CME ERROR: 3 <i>Note: If there is no communication</i>

Example:

To send tone sequence 13#, the application sends:

AT+VTS=1;+VTS=3;+VTS=#

OK

Redial Last Telephone Number DL

Description:

This command redials the last number used in the ATD command. The last number dialed is displayed followed by “;” for voice calls only.

Values: No parameters

Syntax: ATDL

Command	Possible responses
ATDL <i>Note: Redial last number</i>	0146290800; OK <i>Note: Last call was a voice call. Command valid</i>

Automatic Dialing with DTR %D

Description:

This command enables and disables:

- Automatic dialing of the phone number stored in the first location of the ADN phonebook,
- Automatic sending of the short message (SMS) stored in the first location of the SIM.

The number is dialed when DTR OFF switches ON. The short message is sent when DTR OFF switches ON.

Values:

<n> Enable or disables automatic message transmission or number dialing.

Informs the product that the number is a voice rather than a fax or data number.

- 0** Disables automatic DTR number dialing / message transmission.
- 1;** Enables automatic DTR dialing if DTR switches from OFF to ON; Dials the phone number in the first location of the ADN phonebook. **Voice call.**
- 1** Activates automatic DTR dialing if DTR switches from OFF to ON; Dials the phone number in the first location of the ADN phonebook. **Data or Fax call.**
- 2** Activates automatic DTR message transmission if DTR switches from OFF to ON.

Syntax: AT%D<n>[:]

Command	Possible responses
AT%D1; <i>Note: Activates DTR number dialing</i>	OK <i>Note: Command has been executed</i>
DTR is OFF DTR switches ON <i>Note: The number in the first location of the ADN is dialed automatically</i> DTR switches OFF <i>Note: The product goes on-hook</i>	
AT%D2 <i>Note: Activates DTR short message sending</i>	OK <i>Note: Command has been executed</i>

Automatic Answer S0

Description:

This S0 parameter determines and controls the product automatic answering mode.

Values:

<value> is the number of rings before automatic answer (3 characters padded with zeros)
Range of values is 0 to 255.

Syntax: AT S0=<value>

Command	Possible responses
ATS0=2 <i>Note: Automatic answer after 2 rings</i>	OK
ATS0? <i>Note: Current value</i>	002 OK <i>Note: always 3 characters padded with zeros</i>
ATS0=0 <i>Note: No automatic answer</i>	OK <i>Note: Command valid</i>

All others S-parameters (S6,S7,S8 ...) are not implemented.

Incoming Call Bearer +CICB

Description:

This command sets the type of incoming calls when no incoming bearer is given (see +CSNS).

Note: Setting the +CICB command affects the current value of +CSNS.

Values:

<mode>

0: Data

1: Fax

2: Speech

Syntax: AT+CICB=<mode>

Command	Possible responses
AT+CICB=1 <i>Note: If no incoming bearer, force a fax call</i>	OK <i>Note: Command accepted</i>
AT+CICB=2 <i>Note: If no incoming bearer, force a voice call</i>	OK <i>Note: Command accepted</i>
AT+CICB? <i>Note: Interrogate value</i>	+CICB: 2 OK <i>Note: Default incoming bearer: voice call</i>
AT+CICB=? <i>Note: Test command</i>	+CICB: (0-2) OK <i>Note: Speech, data or fax default incoming bearer</i>

Single Numbering Scheme +CSNS

Description:

This command selects the bearer to be used when an MT single numbering scheme call is set up (see +CICB).

Note: Setting the +CSNS command affects the current value of +CICB.

Values:

<mode>

0: Voice

2: Fax

4: Data

Syntax: AT+CSNS

Command	Possible responses
AT+CSNS=2 <i>Note: force a fax call</i>	OK <i>Note: Command accepted</i>
AT+CSNS=0 <i>Note: force a voice call</i>	OK <i>Note: Command accepted</i>
AT+CSNS? <i>Note: Interrogate value</i>	+CSNS: 0 <i>Note: Default incoming bearer: voice call</i>
AT+CSNS=? <i>Note: Test command</i>	+CSNS: (0,2,4) <i>Note: Voice, data or fax default incoming bearer</i>

Gain Control +VGR, +VGT

Description:

This command is used by the application to tune the receive gain of the speaker and the transmit gain of the microphone.

Values: <Rgain> is the reception gain
<Tgain> is the transmission gain

Syntax: AT+VGR=<Rgain>
AT+VGT=<Tgain>

Command	Possible responses
AT+VGR=25	OK <i>Note: Command valid</i>
AT+VGT=45	OK <i>Note: Command valid</i>
AT+VGR? <i>Note: Interrogate value</i>	+VGR: 64 OK <i>Note: Default receive gain</i>
AT+VGR=? <i>Note: Test command</i>	+VGR: (0-255) OK <i>Note: Possible values</i>
AT+VGT? <i>Note: Interrogate value</i>	+VGT: 64 OK <i>Note: Default transmit gain</i>
AT+VGT=? <i>Note: Test command</i>	+VGT: (0-255) OK <i>Note: Possible values</i>

Note: For the AT+VGT? command with controller 1 set, the value is the lower value of range, whereas with controller 2, value corresponds to the entered value with AT+VGT=xx.

The application sends:

AT+VGR=<val>	for receive gain	AT+VGT=<val> Controller 1	for transmit gain Controller 1	AT+VGT=<val> Controller 2	for transmit gain Controller 2
0 to 15	+6 db	0 to 31	+30 db	0	+0 db
16 to 31	+4 db	32 to 63	+33 db	1	+0,5 db
32 to 47	+2 db	64 to 95	+36 db	2	+1 db
48 to 63	+0 db	96 to 127	+39 db	3	+1,5 db
64 to 79	-2 db	128 to 159	+42 db
80 to 95	-4 db	160 to 191	+45 db	19	+9,5 db
96 to 111	-6 db	192 to 223	+48 db	20	+10 db
112 to 127	-8 db	224 to 255	+51 db	21 (**)	+10.5 db
128 to 143	-10 db			22 (**)	+11 db
144 to 159	-12 db			23 (**)	+11.5 db
160 to 175	-14 db		
176 to 191	-16 db			58 (**)	+29 db
192 to 207	-18 db			59 (**)	+29.5 db
208 to 223	-20 db			60 (**)	+30 db
224 to 255 (*)	-22 db			61	+30,5 db
				62	+31 db
			
				101	+50,5 db
				102 to 127	+51 db
				128 to 243	-6,5 db
				244	-6 db
				245	-5,5 db
				246	-5 db
			
				255	-0,5 db

The gain values listed here are relative, for absolute (electrical) values please refer to the specific hardware documentation of the module used in the application.

** For Wismo Quik Q22xx: 21 to 60: - +30db

Microphone Mute Control +CMUT

Description:

This command mutes the microphone input on the product (for the active microphone set with the +SPEAKER command). This command is only allowed during a call.

Values:

<mode>

0: microphone mute off (default value).

1: microphone mute on.

Syntax: **AT+CMUT=<mode>**

Command	Possible responses
AT+CMUT=? <i>Note: Test command</i>	+CMUT: (0,1) OK <i>Note: Enable / disable mute</i>
AT+CMUT? <i>Note: Ask for current value</i>	+CMUT: 0 OK <i>Note: Current value is OFF</i>
AT+CMUT=1 <i>Note: Mute ON (call active)</i>	OK <i>Note: Command valid</i>
AT+CMUT? <i>Note: Ask for current value</i>	+CMUT: 1 OK <i>Note: Mute is active (call active)</i>
AT+CMUT=0 <i>Note: Mute OFF (call not active)</i>	+CME ERROR:3 <i>Note: Command not valid</i>

Speaker & Microphone Selection +SPEAKER

Description

This **specific** command selects the speaker and the microphone set.

Values:

<ActiveSpkMic>

0: Speaker One, Micro One

1: Speaker Two, Micro Two

Syntax: **AT+SPEAKER=<ActiveSpkMic>**

Command	Possible responses
AT+SPEAKER=0 <i>Note: Speaker ONE and Micro ONE</i>	OK <i>Note: Command valid</i>
AT+SPEAKER? <i>Note: Speaker ONE and Micro ONE are active</i>	+SPEAKER: 0 OK
AT+SPEAKER=?	+SPEAKER: (0,1) OK

Echo Cancellation +ECHO

Description:

This command enables, disables or configures the Echo Cancellation functions for voice calls (in rooms, in cars, etc.). It is necessary to tune the Microphone gain (AT+VGT) and the Speaker gain (AT+VGR) before activating the Echo Cancellation.

Values:

<mode>

0: Deactivate Echo

1: Activate Echo

When mode = 1 is chosen, **Algold** is mandatory.

<Algold>

1: Echo cancellation 1

3: Echo cancellation 3

To use Echo cancellation 3, the ECHO feature must be activated.

Echo cancellation 1 (4 parameters):

- The parameter **<Volout>** specifies the maximum attenuation of the switch
<Volout>
0: 31 db (default)
1: 29 db
2: 27 db
3: 25 db
 ...
14: 3 db
15: 1 db
- The parameter **<Step>** specifies the attenuation step between attenuation and no attenuation.
<Step>
0: 1 db
1: 2 db
2: 3 db
- The **<PcmThRel>** parameter specifies the relative threshold between max and min energy information.
 The allowed range is [0 - 31]. Default = 10.
- The **<PcmThMax>** parameter specifies threshold of max energy information.
 The allowed range is [0 - 31]. Default = 7.

Echo Cancellation 3 (3 parameters):

- **<AlgoParam>** high value leads to high echo attenuation but the full-duplex quality will be less efficient.
 The allowed range is [0 ; 63]. (**30** by default)
- **<NoiseThres>** indicates the noise threshold. Low value leads to high noise attenuation. The threshold 32767 indicates no noise attenuation. The allowed range is [0 ;32767].
 The default is **8000**.
- **<NmbTaps>** indicates the Number of Taps of the Adaptive Filter. The allowed range is [64 -256]. The default is **256**.
 64 taps = short Echo
 256 taps = long Echo.

Read Command: AT+ECHO?

This command returns the current settings of the Echo cancellation.

Returns:

+ECHO: <Status>,<Algold>,<Param1>,<Param2>,<Param3>,<Param4>,<Param5>,<Param6>

The number of parameters displayed depends on the algorithm used. For Echo cancellation 1, 4 parameters are displayed, 3 parameters are displayed for Echo cancellation 3.

<Status>

- 0** Echo Deactivated.
- 1** Echo Activated for Mic/Spk one.
- 2** Echo Activated for Mic/Spk two.
- 3** Reset the product.

Note: You can activate/deactivate the echo cancellation during a call without resetting the product if the <Algold> parameter is not changed, but you have to use the syntax with all parameters: **AT+ECHO=1,3,30,8000,256** for instance.

Syntax: **AT+ECHO= <mode> [,<Algold>, <Param1>,<Param2>,<Param3>,<Param4>,<Param5>,<Param6>]**

Command	Possible responses
AT+CMEE=1 <i>Note: Enables the use of result code</i>	OK
AT+SPEAKER?	+ SPEAKER: 0 OK <i>Note: Speaker ONE and Micro ONE are active</i>
AT+SIDET=0 <i>Note: Deactivate the Sidetone</i>	OK
AT+SIDET?	+SIDET: 0,0
AT+ECHO? <i>Note: Read current settings</i>	+ECHO: 0,1,0,3,10,7 OK
AT+ECHO=1,1,0,3,10,7 <i>Note: Active Echo cancellation 1 for Mic/Spk one.</i>	OK
AT+ECHO? <i>Note: Read current settings</i>	+ECHO: 1,1,0,3,10,7 OK
AT+ECHO=1,3,30,8000,256 <i>Note: Activate the Echo cancellation 3</i>	+CME ERROR: 519 <i>Note: The new algorithm will be activated after a reset of the product</i>
AT+ECHO? <i>Note: Read the Echo cancellation settings</i>	+ECHO: 3,3,30,8000,256 OK
AT+CFUN=1 <i>Note: Reset the product</i>	OK
AT+ECHO? <i>Note: Read current settings</i>	+ECHO: 1,3,30,8000,256 OK
AT+ECHO=0 <i>Note: Deactivate the Echo Cancellation</i>	OK

SideTone Modification +SIDET

Description:

This command sets the level of audio feedback in the speaker (microphone feedback in the speaker).

Values:

<val1>

- 0: SideTone is disabled
- 1: SideTone is enabled

<val2> (default value 0 will be used if this parameter is not given)

- 0: 0 db
- 1: - 6 db
- 2: - 12 db
- 3: - 18 db

Syntax: AT+SIDET=<val1>,<val2>

Command	Possible responses
AT+SIDET=1,0	OK <i>Note: Command valid</i>
AT+SIDET? <i>Note: Current value</i>	+SIDET: 1,0 OK <i>Note: Command valid</i>

Initialize Voice Parameters +VIP

Description:

This command allows factory settings for voice parameters to be restored from EEPROM.

These voice parameters include:

- Gain control (+VGR & +VGT commands)
- Gain controller (+WSVG command)
- Microphone mute control (+CMUT command)
- Speaker & Microphone selection (+SPEAKER command)
- Echo cancellation (+ECHO command)
- Side tone modification (+SIDET command)

Values:

<n>

- 1 Restore all voice parameters.
- Other values are not supported.

Syntax: AT+VIP=<n>

Command	Possible responses
AT+VIP?	+VIP: 1 OK
AT+VIP=2 <i>Note: Syntax error</i>	+CME ERROR: 3
AT+VIP=1 <i>Note: Restore the factory settings from EEPROM</i>	OK <i>Note: The command has been executed</i>
AT+VIP=1 <i>Note: Restore the factory settings from EEPROM with the current Echo cancellation algo (different of the default algo).</i>	CME ERROR: 519 <i>Note: Reset the product to accept the new algo.</i>
AT+VIP=? <i>Note: List of supported <n>s</i>	+VIP: (1) OK

CHAPTER 6 - NETWORK SERVICE COMMANDS

Signal Quality +CSQ

Description:

This command determines the *received signal strength indication* (<rss>) and the *channel bit error rate* (<ber>) with or without a SIM card inserted.

Values:

<rss>:

0: -113 dBm or less

1: -111 dBm

2 to 30: -109 to -53 dBm

31: -51dBm or greater

99: not known or not detectable

<ber>: 0...7: as RXQUAL values in the table GSM 05.08

99: not known or not detectable

Syntax: AT+CSQ

Command	Possible responses
AT+CSQ	+CSQ: <rss>,<ber> OK <i>Note: <rss> and <ber> as defined below</i>

Operator Selection +COPS

Description:

There are three possible ways of selecting an operator (PLMN):

- 1) The product is in **manual** mode. It then tries to find the operator specified by the application and if found, tries to register.
- 2) The product is in **automatic** mode. It then tries to find the home operator and if found, tries to register. If not found, the product automatically searches for another network.
- 3) The product enters into **manual/automatic** mode, and then tries to find an operator as specified by the application (as in manual mode). If this attempt fails it enters **automatic** mode. If this is successful, the operator specified by the application is selected. The mobile equipment then enters into **automatic** mode.

Note: The read command returns the current mode and the currently selected operator. In manual mode, this PLMN may not be the one set by the application (as it is in the search phase). These commands are not allowed during one communication.

Values:

<mode>

0: automatic (**default** value)

1: manual

2: deregistration ; ME will be unregistered until <mode>=0 or 1 is selected.

3: set only <format> (for read command AT+COPS?)

4: manual / automatic (<oper> shall be present), if manual selection fails, automatic mode is entered.

<format>: format of <oper> field

<format>

0: long alphanumeric format <oper>

1: short alphanumeric format <oper>

2: numeric <oper> (**default** value) <stat>: status of <oper>

<stat>

0: unknown

1: available

2: current

3: forbidden

<oper>: operator identifier (MCC/MNC in numeric format only for operator selection)

The long alphanumeric format can be up to 16 characters long (see Appendix A for operator names description, field is "Name"). The short alphanumeric format can be up to 8 characters long.

Syntax: AT+COPS=<mode>, [<format> [, <oper>]]

To force an attempt to select and register on a network, the application must send the following command:

Possible responses for AT+COPS=<mode>:

OK (Network is selected with full service)
+CME ERROR: 30 (No network service),
+CME ERROR: 32 (Network not allowed – emergency calls only)
+CME ERROR: 3 (not allowed during one Communication)
+CME ERROR: 4 (Incorrect parameters)
+CME ERROR: 527 (Please wait, and retry your selection later)
+CME ERROR: 528 (Location update failure – emergency calls only)
+CME ERROR: 529 (Selection failure – emergency calls only)

Response syntax for AT+COPS?:

+COPS: <mode> [, <format>, <oper>]

Response syntax for AT+COPS=?:

+COPS: [list of supported (<stat>, long alphanumeric <oper>, short alphanumeric <oper>s, numeric <oper>) s]

If an incoming call occurs during a PLMN list request, the operation is aborted

(**+CME ERROR: 520**) and the unsolicited RING appears.

Command	Possible responses
AT+COPS? <i>Note: Ask for current PLMN</i>	+COPS: 0,2,20801 OK <i>Note: Home PLMN is France Telecom Orange</i>
AT+COPS=? <i>Note: Ask for PLMN list</i>	+COPS: (2,"F Itin�ris", "Itline", "20801"), (3,"F SFR", "SFR", "20810") OK <i>Note: Home PLMN is France Telecom SFR network has been detected</i>
AT+COPS=1,2,20810 <i>Note: Ask for registration on SFR network</i>	+CME ERROR: 32 <i>Note: Network not allowed – emergency calls only</i>
AT+COPS=1,1,23433 <i>Note: Ask for registration on UK Orange network</i>	+CME ERROR: 529 <i>Note: Selection failed – emergency calls only</i>
AT+COPS=0 <i>Note: Ask for registration on home network</i>	OK <i>Note: Succeeded</i>
AT+COPS=3,0 <i>Note: Set <format> to long alphanumeric</i>	OK
AT+COPS? <i>Note: Ask for current PLMN</i>	+COPS: 0,0,"Orange F" OK <i>Note: Home PLMN is France Telecom Orange</i>
AT+COPS=2 <i>Note: Ask for deregistration from network</i>	OK <i>Note: Succeeded</i>
AT+COPS? <i>Note: Ask for current PLMN</i>	+COPS: 2 <i>Note: ME is unregistered until <mode>=0 or 1 is selected</i>

Network Registration +CREG

Description:

This command is used by the application to ascertain the registration status of the product.

Values:

<mode>

- 0: Disable network registration unsolicited result code (**default**)
- 1: Enable network registration code result code +CREG: <stat>
- 2: Enable network registration and location information unsolicited result code +CREG: <stat>,<lac>,<ci> if there is a change of network cell.

<stat>

- 0: not registered, ME is not currently searching for a new operator.
- 1: registered, home network.
- 2: not registered, ME currently searching for a new operator to register to.
- 3: registration denied.
- 4: unknown.
- 5: registered, roaming.

<lac>: string type; two byte location area code in hexadecimal format (e.g. "00C3" equals 195 in decimal).

<ci>: string type; two byte cell ID in hexadecimal format.

Syntax: Command Syntax : AT+CREG= <mode>

Response syntax: +CREG: <mode>, <stat> [,<lac>,<ci>] for AT+CREG? Command only

Command	Possible responses
AT+CREG?	+CREG: <mode>,<stat> OK <i>Note: As defined here-above</i>
AT+CREG=0 <i>Note: Disable network registration unsolicited result code</i>	OK <i>Note: Command valid</i>
AT+CREG=1 <i>Note: Enable network registration unsolicited result code</i>	OK <i>Note: Command valid</i>
AT+CREG=2 <i>Note: Enable network registration and location information unsolicited result code</i>	OK <i>Note: Command valid</i>
AT+CREG=?	+CREG: (0-2) <i>Note: 0,1,2 <mode> values are supported</i>

Read Operator Name +WOPN

Description:

This command returns the operator name in alphanumeric format when given the numeric format.

With E-ONS feature, lac is an optional parameter to read names from OPL/PNN sim files. If it is not entered, name will be given with current lac. Note that in limited service, current lac is set to 0.

Values:

<format> is the required format. Only long (0) and short (1) alphanumeric formats are supported.

<NumOper> is the operator in numeric format.

<AlphaOper> is the operator in long or short alphanumeric format (see Appendix A for description).

<lac> is the two byte Location Area Code to be used to get the PLMN name. If it is not entered, Current lac will be used (0 if limited service).

Syntax:

Command syntax: AT+WOPN=<format>,<NumOper>

Response syntax: +WOPN: <format>,<AlphaOper>

Command	Possible responses
AT+WOPN=? <i>Note: Test command</i>	OK
AT+WOPN=0,20801 <i>Note: Give an operator in numeric format</i>	+WOPN: 0,"Orange F" OK <i>Note: Alphanumeric answer</i>
AT+WOPN=0,99999 <i>Note: Give a wrong operator</i>	+CME ERROR: 22 <i>Note: Not found</i>
AT+WOPN=0,2081,36 <i>Note: Give an operator in numeric format for lac 36</i>	+WOPN: 0, "OrangeF" OK <i>Note: Alphanumeric answer</i>

Selection of Preferred PLMN List +CPLS

Description:

This command selects one PLMN selector with access technology list in the SIM card that is used by AT+CPLS command.

Values:

<List>:

0: User controlled PLMN selector with access technology EF_PLMNwAct

Note: if this file is not found EF_PLMNsel will be selected

1: Operator controlled PLMN selector with access technology EF_OPLMNwAct

2: Home PLMN selector with access technology EF_HPLMNwAct

Syntax: AT+CPLS= <List>

Command	Possible responses
AT+CPLS? <i>Note: Ask for selection of the SIM file</i>	+CPLS: 1 OK <i>Note: EF_OPLMNwAct is selected</i>
AT+CPLS=0 <i>Note: selection of EF_PLMNwAct</i>	<i>Note: if EF_PLMNwAct is not present, EF_PLMNsel will be selected</i>
AT+CPLS=1 <i>Note: selection of EF_OPLMNwAct</i>	+CME ERROR: 3 <i>Note: EF_OPLMNwAct is not present</i>
AT+CPLS=? <i>Note: Get possible values</i>	+CPLS: (0-2) OK <i>Note: The 3 files with Acces technology are present and can be selected</i>
AT+CPLS=? <i>Note: Get possible values</i>	+CPLS: (0) OK <i>Note: Only EF_PLMNwAct or EF_PLMNsel can be selected</i>

Preferred Operator List +CPOL

Description:

This command edits (or updates) the SIM preferred list of networks. This list is read in the SIM file selected by the command AT+CPLS.

Values:

<index>: position of the operator record in the Sim preferred operator list. Use **AT+CPOL=?** to view the maximum index of the selected EF.

<format>:

- 0 long alphanumeric format for <oper>
- 1 short alphanumeric format for <oper>
- 2 numeric format for <oper>

<oper>: characterstring or integer (see <format>) indicating operator identifier.

<GSM_Act>: GSM access technology

<GSMcomp_Act>: GSM compact access technology

<Utran_Act>: UTRA access technology

- 0 access technology not selected
- 1 access technology selected

Syntax: AT+CPOL=

[<index>] [,<format>[,<oper>[,<GSM_Act>,<GSMcomp_Act>,<Utran_Act>]]]

The different possibilities are:

- AT+CPOL = <index> to delete an entry.
- AT+CPOL = , <format> to set the format used by the read command (AT+CPOL?).
- AT+CPOL = , <format>, <oper> to put <oper> in the next free location.
- AT+CPOL = <index>, <format>, <oper> to write <oper> in the <format> at the <index>.
- AT+CPOL = <index>,<format>,<oper>,<GSM_Act>,<GSMcp_Act>,<Utran_Act>
To write <oper> in the <format> at the <index> precising the access technology (in the case of EF_PLMNwact, EF_HPLMNwact or EF_OPLMNwact is present).

Note: Per default if Acces technology parameters are not given, the GSM access technology will be chosen.

The supported format are those of the +COPS command.

The length of this list is limited to 85 entries for EF_PLMNsel, and 51 for EF_PLMNwAct, EF_OPLMNwAct, EF_HPLMNwAct.

(See table on next page)

Command	Possible responses
AT+CPOL? <i>Note: Ask for preferred list of networks With only EF_PLMNsel present</i>	+CPOL:1,2,26201 +CPOL: 6,2,20810 OK <i>Note: Preferred list of networks in numeric format (read in EF_PLMNsel)</i>
AT+CPOL? <i>Note: Ask for preferred list of networks With EF_PLMNwAct selected and present</i>	+CPOL:1,2,26201,1,0,0 +CPOL: 6,2,20810,1,0,0 OK <i>Note: Preferred list of networks in numeric format (read in EF_PLMNwAct) GSM acces technology selected GSM compact acces technology not selected Utran acces technology not selected</i>
AT+CPOL=,0 <i>Note: Select long alphanumeric format</i>	OK
AT+CPOL? <i>Note: Ask for preferred list of networks With only EF_PLMNsel present</i>	+CPOL: 1,0,"D1-TELEKOM" +CPOL: 6,0,"F SFR" OK <i>Note: Preferred list of networks in long alphanumeric format</i>
AT+CPOL=7,2,20801 <i>Note: Add a network to the list</i>	OK
AT+CPOL? <i>Note: Ask for preferred list of networks With only EF_PLMNsel present</i>	+CPOL: 1,0,"D1-TELEKOM" +CPOL: 6,0,"F SFR" +CPOL: 7,0,"Orange F" OK <i>Note: Preferred list of networks in long alphanumeric format</i>
AT+CPOL=7 <i>Note: Delete 7th location</i>	OK
AT+CPOL? <i>Note: Ask for preferred list of networks With only EF_PLMNsel present</i>	+CPOL: 1,0,"D1-TELEKOM" +CPOL: 6,0,"F SFR" OK <i>Note: Preferred list of networks in long alphanumeric format</i>
AT+CPOL=8,2,77777 <i>Note: Add a new network to the list With only EF_PLMNsel present</i>	OK
AT+CPOL=8,2,77777,0,0,1 <i>Note: Add a new network to the list With EF_PLMNwact present</i>	OK <i>Note: Acces technology UTRAN is selected</i>
AT+CPOL=8,2,77777 <i>Note: Add a new network to the list With EF_PLMNwact present</i>	OK <i>Note: Per default Acces technology GSM is selected</i>
AT+CPOL? <i>Note: Ask for preferred list of networks With only EF_PLMNsel present</i>	+CPOL: 1,0,"D1-TELEKOM" +CPOL: 6,0,"F SFR" +CPOL: 8,2,77777" OK <i>Note: Preferred list of networks in long alphanumeric format but 8th entry is unknown so the product edits it in the numeric format</i>
AT+CPOL=9,0,"Orange F" <i>Note: Add a new network to the list (text format)</i>	
AT+CPOL? <i>Note: Ask for preferred list of networks With only EF_PLMNsel present</i>	+CPOL: 1,0,"D1-TELEKOM" +CPOL: 6,0,"F SFR" +CPOL: 8,2,77777" +CPOL: 9,0,"Orange F" OK <i>Note: Preferred list of networks in long alphanumeric format</i>
AT+CPOL=?	+CPOL: (1-16),(0-2) OK <i>Note: The EF can accept 16 records. Supported formats are 0, 1, or 2.</i>

Read Operator Name +COPN

Description:

This command returns the list of all operator names (in numeric and alphanumeric format) stored in the module.

Values:

<NumOper>: is the operator in numeric format

<AlphaOper>: is the operator in long alphanumeric format

Command Syntax: AT+COPN

Command Response: +COPN: <NumOper>,<AlphaOper>

Command	Possible responses
AT+COPN <i>Note: Ask for list of operators</i>	+COPN: 23201,"A1" +COPN: 23203,"Amax." +COPN: 23207,"A tele.ring" +COPN: 23205,"one" ... OK +CME ERROR: <err>
AT+COPN=?	OK

CHAPTER 7 - SECURITY COMMANDS

Enter PIN +CPIN

Description:

This command enters the ME passwords (CHV1 / CHV2 / PUK1 / PUK2, etc.), that are required before any ME functionality can be used. **CHV1/CHV2** is between **4** and **8** digits long, **PUK1/PUK2** is **only 8 digits** long. If the user application tries to make an outgoing call before the SIM PIN code (CHV1) has been confirmed, then the product will refuse the “ATD” command with a “+CME ERROR: 11” (SIM PIN required). The application is responsible for checking the PIN after each reset or power on - if the PIN was enabled.

Values:

<pin> is the personal identification number

<puk> is the personal unblocking key needed to change the PIN.

Syntax: AT+CPIN=<pin>

Command	Possible responses
AT+CPIN=1234 <i>Note: Enter PIN</i>	OK <i>Note: PIN code is correct</i>
AT+CPIN=5678 <i>Note: Enter PIN</i>	+CME ERROR: 3 <i>Note: Operation not allowed, PIN previously entered</i>

After 3 unsuccessful attempts to enter the PIN (Personal Identification Number), the PUK (Personal Unblocking Key) will be required.

PUK validation forces the user to enter a new PIN code as a second parameter and this will be the new PIN code if PUK validation succeeds. CHV1 is then enabled if PUK1 is correct. The application therefore uses this command: **AT+CPIN=<Puk>,<NewPin>**

Command	Possible responses
AT+CPIN=00000000,1234 <i>Note: Enter PUK and new PIN</i>	+CME ERROR: 16 <i>Note: Incorrect PUK</i>
AT+CPIN=12345678,1234 <i>Note: Enter PUK and new PIN, 2nd attempt</i>	OK <i>Note: PUK correct, new PIN stored</i>

To determine which code must be entered (or not), the following query command can be used:

AT+CPIN? The possible responses are:

+CPIN: READY	<i>ME is not pending for any password</i>
+CPIN: SIM PIN	<i>CHV1 is required</i>
+CPIN: SIM PUK	<i>PUK1 is required</i>
+CPIN: SIM PIN2	<i>CHV2 is required</i>
+CPIN: SIM PUK2	<i>PUK2 is required</i>
+CPIN: PH-SIM PIN	<i>SIM lock (phone-to-SIM) is required</i>
+CPIN: PH-NET PIN	<i>Network personalisation is required</i>
+CME ERROR: <err>	<i>SIM failure (13) absent (10) etc...</i>

Please note that in this case the mobile equipment does not end its response with the OK string.

The response +CME ERROR: 13 (SIM failure) is returned after 10 unsuccessful PUK attempts. The SIM card is then out of order and must be replaced by a new one.

Example: 3 failed PIN validations + 1 successful PUK validation

AT+CPIN?	<i>Read the PIN status</i>
+CPIN: SIM PIN	<i>The product requires SIM PIN</i>
AT+CPIN=1235	<i>First attempt to enter a SIM PIN</i>
+CME ERROR: 16	<i>Wrong PIN</i>
AT+CPIN=1236	<i>Second attempt</i>
+CME ERROR: 16	<i>Wrong PIN</i>
AT+CPIN=1237	<i>Third attempt</i>
+CME ERROR: 16	<i>Wrong PIN</i>
AT+CPIN?	<i>Read PIN state</i>
+CPIN: SIM PUK	<i>The product requires PUK</i>
AT+CPIN=99999999,5678	<i>The PUK is entered, the new PIN shall be 5678 PUK validation is</i>
OK	<i>OK. New Pin is 5678</i>
AT+CPIN?	<i>Read PIN state</i>
+CPIN: READY	<i>The product is ready</i>

If the user tries to do something which requires PIN2 (CHV2), the product will refuse the action with a “+CME ERROR: 17” (SIM PIN2 required). The product then waits for SIM PIN2 to be given. Of course, if SIM PIN2 is blocked, SIM PUK2 is required instead of SIM PIN2.

For example, the product needs PIN2 to write in the fixed dialing phonebook (FDN) , so if SIM PIN2 authentication has not been performed during the current session, SIM PIN2 is required

Command	Possible responses
AT+CPBS="FD" <i>Note: Choose FDN</i>	OK
AT+CPBW=5,"01290917",129,"Jacky" <i>Note: Write in FDN at location 5</i>	+CME ERROR: 17 <i>Note: SIM PIN2 is required</i>
AT+CPIN?	SIM PIN2 <i>Note: SIM PIN2 is required</i>
AT+CPIN=5678 <i>Note: Enter SIM PIN2</i>	OK
AT+CPBW=2,"01290917",129,"Jacky" <i>Note: Write in FDN at location 5</i>	OK <i>Note: Now writing in FDN is allowed</i>

Note: Please note that the product only requests PIN2 or PUK2 once. Therefore, if they are not entered properly, the next +CPIN? command will return “+CPIN: READY”.

Enter PIN2 +CPIN2

Description:

This command validates the PIN2 code (CHV2) or the PUK2 code (UNBLOCK CHV2) and defines a new PIN2 code. Of course, the +CPIN command allows PIN2 or PUK2 codes to be validated, but only when the last command executed resulted in PIN2 authentication failure. PIN2 length is between 4 and 8 digits; PUK2 length is 8 digits only.

Values:

<pin2> is the personal identification number 2

<puk2> is the personal unblocking key 2 needed to change the PIN 2

<newpin2>

Note: PIN2 length is between 4 and 8 digits; PUK2 length is 8 digits only.

Syntax: AT+CPIN2=<pin2>

Command	Possible responses
AT+CPIN2=1234 <i>Note: Enter PIN2</i>	OK <i>Note: PIN2 code is correct</i>
AT+CPIN2=5678 <i>Note: Enter PIN2</i>	+CME ERROR: 3 <i>Note: Operation not allowed, PIN2 previously entered</i>

After 3 unsuccessful attempts, PUK2 will be required. PUK2 validation forces the user to enter a new PIN2 code as a second parameter and this will be the new PIN2 code if PUK1 validation succeeds. The application uses this command: **AT+CPIN2=<puk2>,<NewPin2>**

Command	Possible responses
AT+CPIN2=00000000,1234 <i>Note: Enter PUK2 and new PIN2</i>	+CME ERROR: 16 <i>Note: Incorrect Password (PUK2)</i>
AT+CPIN2=12345678,1234 <i>Note: Enter PUK2 and new PIN2, 2nd attempt</i>	OK <i>Note: PUK2 correct, new PIN2 stored</i>

To determine which code must be entered (or not), the following query command can be used:

AT+CPIN2?

The possible responses are:

+CPIN2: READY	<i>No PIN2 is needed</i>
+CPIN2: SIM PIN2	<i>PIN2 is required</i>
+CPIN2: SIM PUK2	<i>PUK2 is required</i>
+CME ERROR: <err>	<i>Absent (10) etc...</i>

PIN Remaining Attempt Number +CPINC

Description:

This command gets the number of valid attempts for PIN1 (CHV1), PIN2 (CHV2), PUK1 (UNBLOCK CHV1) and PUK2 (UNBLOCK CHV2) identifiers.

Values

<n1>, **<n2>** are the attempts left for PIN1, PIN2 (0 = blocked, 3 max)

<k1>, **<k2>** are the attempts left for PUK1, PUK2 (0 = blocked, 10 max)

For this to work, the card should be present at the time of initialization; otherwise, an error will be sent (+CME ERROR: 10).

Command syntax: AT+CPINC

Response syntax: +CPINC: <n1>,<n2>,<k1>,<k2>

Command	Possible responses
AT+CPINC <i>Note: Get the number of attempts left</i>	+CPINC: 2,3,10,10 OK <i>Note: First CHV1 attempt was a failure</i>
AT+CPINC? <i>Note: Get current values</i>	+CPINC: 2,3,10,10 OK <i>Note: First attempt was a failure</i>
AT+CPINC=? <i>Note: Get possible values</i>	OK

Facility Lock +CLCK

Description:

This command locks, unlocks or interrogates an ME or network facility <fac>.

Note: Test SIM cards (with MCC=001 & MNC=01) do not check “PS”, “PN”, “PU”, “PP” and “PC” locks.

Values:

<fac> supported facilities:

- “PS”: SIM lock facility with an 8-digit password.
- “SC”: PIN enabled (<mode> = 1) / disabled (<mode> = 0)
- “AO”: BAOC (Barr All Outgoing Calls)
- “OI”: BOIC (Barr Outgoing International Calls)
- “OX”: BOIC-exHC (Barr Outgoing International Calls except to Home Country)
- “AI”: BAIC (Barr All Incoming Calls)
- “IR”: BIC-Roam (Barr Inc. When Roaming outside Home Country)
- “AB”: All Barring services
- “AG”: All outGoing barring services
- “AC”: All inComing barring services
- “PN”: Network lock with an 8-digit password (NCK).
- “PU”: Network Subset lock with an 8-digit password (NSCK).
- “PP”: Service Provider lock with an 8-digit password (SPCK).
- “PC”: Corporate lock with an 8-digit password (CCK).
- “FD”: SIM Fixed Dialing Numbers (FDN) memory feature (PIN2 is required as <password>)

<mode>

- 0: unlock the facility
- 1: lock the facility
- 2: query status

<class> A facility status can be changed for only one class, or for all classes (7 or omitted).

- 1: Voice (telephony)
- 2: Data (apply to all bearer services)
- 4: Fax (facsimile services)
- 8: Short Message service
- 7: Equal to all classes (Default value)

Any attempt to combine different classes will result in activation / deactivation / interrogation of all classes.
Password maximum length is given with the AT+CPWD=? Command.

Note: It will not possible to lock the FDN phonebook if this one is not loaded.

Command syntax: AT+CLCK= <fac>,<mode>[,<passwd>[,<class>]]

Response syntax: +CLCK: <status> [,<class1>]<CR><LF>+CLCK: <status>,<class2> [...]

Command	Possible responses
AT+CLCK="SC",1,1234 <i>Note: Enable PIN</i>	OK <i>Note: PIN was correct</i>
AT+CLCK? <i>Note: Read PIN status</i>	+CLCK:(“PS”,0),(“SC”,0),(“FD”,0),(“PN”,0),(“PU”,0),(“PP”,0),(“PC”,0) OK <i>Note: PIN is enabled, no SIM lock, no network lock, no information on Call barring</i> (no longer supported in GSM Technical Specification 07.07)
AT+CLCK="SC",0,5555 <i>Note: Disable PIN</i>	+CME ERROR: 16 <i>Note: PIN was wrong</i>
AT+CPIN=1234 <i>Note: Enter PIN</i>	OK <i>Note: PIN was good</i>
AT+CLCK=? <i>Note: Request supported facilities</i>	+CLCK: (“PS”,“SC”,“AO”,“OI”,“OX”,“AI”,“IR”,“AB”,“AC”,“FD”,“PN”,“PU”,“PP”,“PN”) OK <i>Note: Supported facilities</i>
AT+CLCK="PN",1,12345678 <i>Note: Activate network lock</i>	OK <i>Network lock activated</i>
AR+CLCK="AO",1,1234,2 <i>Note: Activate all outgoing calls except data calls</i>	OK <i>Note: Call barring is activate</i>
AT+CLCK="AO",2 <i>Note: Query BAOC status</i>	+CLCK: 1,2 OK <i>Note: BAOC activate for data calls only</i>
AT+CLCK="SC",0,0000 <i>Note: Disable PIN</i>	+CME ERROR: 521 <i>Note: PIN deactivation is forbidden with this SIM card</i>

Change Password +CPWD

Description:

This command changes a password (PIN, call barring, NCK, etc.). The facility values (<fac>) are the same as for the +CLCK command with a "P2" facility to manage SIM PIN2. For the network lock ("PN"), unlocking is forbidden after 10 failed attempts to disable (unlock) the network lock with an incorrect password.

Values:

fac> supported facilities:

"PS": SIM lock facility with an 8-digit password.

"SC": PIN enabled (<mode> = 1) / disabled (<mode> = 0)

"AO": BAOC (Barr All Outgoing Calls)

"OI": BOIC (Barr Outgoing International Calls)

"OX": BOIC-exHC (Barr Outgoing International Calls except to Home Country)

"AI": BAIC (Barr All Incoming Calls)

"IR": BIC-Roam (Barr Inc. When Roaming outside Home Country)

"AB": All Barring services

"AG": All outGoing barring services

"AC": All inComing barring services

"P2":

"FD": SIM Fixed Dialing Numbers (FDN) memory feature (PIN2 is required as <password>)

"PN"

"PU"

"PP"

"PC"

<oldpwd>,<newpwd> 4 or up to 8 or 16 digits according to the facility.

Syntax: AT+CPWD= <fac>, <oldpwd>, <newpwd>

Command	Possible responses
AT+CPWD=? <i>Note: Possible values</i>	+CPWD: ("PS",8),("SC",8),("AO",4),("OI",4),("OX",4), ("AI",4),("IR",4),("AB",4),("AG",4),("AC",4), ("P2",8),("FD",8),("PN",8),("PU",8),("PP",8), ("PC",8) OK <i>Note: CHV1/CHV2 must be on 8 digits maximum (4mn)</i> <i>For call barring, on 4 digits maximum</i>
AT+CPWD="SC",1234,5555 <i>Note: Change PIN</i>	OK <i>Note: PIN was correct</i>
AT+CPWD="SC",1234,5555 <i>Note: Change PIN</i>	+CME ERROR: 16 <i>Note: PIN was wrong</i>
AT+CPIN=5555 <i>Note: Enter PIN</i>	OK <i>Note: PIN was correct</i>
AT+CPWD="PN",12345678,00000000 <i>Note: Change NCK</i>	OK <i>Note: NCK changed for net lock</i>

CHAPTER 8 - PHONEBOOK COMMANDS

Select Phonebook Memory Storage +CPBS

Description:

This command selects phonebook memory storage. The available phonebooks are:

Values:

- “SM”: ADN (SIM phonebook)
- “FD”: FDN (SIM Fix Dialing, restricted phonebook)
- “ON”: MSISDN (SIM own numbers)
- “EN”: EN (SIM emergency number)
- “LD”: LND (combined ME and SIM last dialing phonebook)
- “MC”: MSD (ME missed calls list)
- “ME”: ME (ME phonebook)
- “MT”: MT (combined ME and SIM phonebook)
- “RC”: LIC (ME received calls list)
- “SN”: SDN (Services dialing phonebook)

Syntax: AT+CPBS

Command	Possible responses
AT+CPBS="SM" <i>Note: Select ADN phonebook</i>	OK <i>Note: ADN phonebook is selected</i>
AT+CPBS=? <i>Note: Possible values</i>	+CPBS: ("SM", "LD", "MC", "ON", "ME", "RC", "MT", "SN") OK <i>Note: only "EN" phonebook is not supported with this SIM card.</i>
AT+CPBS? <i>Note: Status</i>	+CPBS:"SM",10,20 OK <i>Note: ADN phonebook selected, 10 locations used, 20 locations available</i>

The ADN phonebook could not be selected as FDN is active.

Read Phonebook Entries +CPBR

Description:

This command returns phonebook entries for a range of locations from the current phonebook memory storage selected with +CPBS.

Note: For all phonebook read commands (+CPBR, +CPBF, +CPBN, +CPBP, +CNUM), the TON/NPI MSB of each number is set to 1 (ex: a TON/NPI stored as 17 is displayed as 145).

Values: <first_entry>,<last_entry> Location or range of locations of the phonebook entry or entries

Syntax: AT+CPBR

Command	Possible responses
AT+CPBR=? <i>Note: Test command</i>	+CPBR: (1-50),20,10 OK <i>Note: 50 locations (from 1 to 50), max length for phone number is 20 digits, 10 characters max for the text</i>
AT+CPBR=12,14 <i>Note: Read entries from 12 to 14</i>	+CPBR: 12,"112",129,"Emergency" +CPBR: 13,"+331290909",145,"Fred" +CPBR: 14,"0146290808",129,"Zazi" OK <i>Note: Display locations 12,13,14 with location, number, type (TON/NPI), Text</i>
AT+CPBR=10 <i>Note: Read entry 10</i>	+CPBR:10,"0146290921",129,"Rob" OK <i>Note: Display location 10</i>
AT+CPBR=11 <i>Note: Read entry 11 (UCS2 format)</i>	+CPBR:11,"0146290921",129,"8000010002FFFF" OK <i>Note: Display location 11</i>
AT+CPBR=52 <i>Note: Read entry 52 (wrong)</i>	+CME ERROR: 21 <i>Note: Invalid index</i>

Find Phonebook Entries +CPBF

Description:

This command returns phonebook entries with alphanumeric fields starting with a given string. The AT+CPBF="" command can be used to display all phonebook entries sorted in alphabetical order. This command is not allowed for "LD", "RC", "MC", "SN" phonebooks and for the "EN" phonebook, which does not contain alphanumeric fields. It is possible to use this command with UCS2 strings. If a wrong UCS2 format is entered, the string is considered as an ASCII string.

Syntax: <string> Searched starting string (depends on the format of the data stored in the phonebooks)

Syntax: AT+CPBF

Command	Possible responses
AT+CPBF=? <i>Note: Test command</i>	+CPBF: 20,10 OK <i>Note: Max length for phone number is 20 digits, 10 characters for the text</i>
AT+CPBF="E" <i>Note: Read entries with "E"</i>	+CPBF: 12,"112",129,"Emergency" +CPBF: 15,"+331290101",145,"Eric" OK <i>Note: Display locations with text field starting with "E"</i>
AT+CPBF="H" <i>Note: Read entries with "H"</i>	+CME ERROR: 22 <i>Note: Entry not found</i>
AT+CPBF="800001FFFF" <i>Note: Read entries starting with 0001 UCS2 character</i>	+CPBF: 11, "0146290921",129,"8000010002FFFF" OK <i>Note: Display locations with text field starting with 0001 UCS2 character</i>
AT+CPBF="8045C" <i>Note: Read entries with "8045C" (ASCII format)</i>	+CME ERROR: 22 <i>Note: Entry not found. The string has a wrong UCS2 format, it is therefore considered as an ASCII string</i>

Write Phonebook Entry +CPBW

Description:

This command writes a phonebook entry in location number <index> in the current phonebook memory storage. “RC” and “MC” phonebooks could be erased only by +CPBW. Adding a field and/or modifying a field is not allowed for these phonebooks.

This command is not allowed for “EN”, “LD”, “MC”, “RC”, “MT”, and “SN” phonebooks (they cannot be written).

<index> Integer type value depending on the capacity of the phonebook memory.

<number> Phone number in ASCII format.

<type> TON/NPI (Type of address byte in integer format).

Note: for the <type> parameter, all values are allowed from 0 to 255, but the MSB will be set to 1 in all cases (ex: a <type> value of 17 will be written as 145).

<text> String type.

Note: For the <text> parameter all strings starting with “80”, “81” or “81” are considered in UCS2 format. See the Appendix G (Coding of Alpha fields in the SIM for UCS2).

Note: +CSCS (Select Character set) does not affect the format for phonebook entries.

Syntax: AT+CPBW=<index>[,<number>[,<type>[,<text>]]]

Command	Possible responses
AT+CPBW=? <i>Note: Test command</i>	+CPBW: (1-50),20,(129,145),10 OK <i>Note: 50 locations, phone number = 20 digits max, TON/NPI of 129 or 145, text length = 10</i>
AT+CPBW= 3 <i>Note: Erase location 3</i>	OK <i>Note: Location 3 erased</i>
AT+CPBW=5,"112",129,"SOS" <i>Note: Write at location 5</i>	OK <i>Note: Location 5 written</i>
AT+CPBW=5,"01290917",129,"Jacky" <i>Note: Overwrite location 5</i>	OK <i>Note: Location 5 overwritten</i>
AT+CPBW=6,"01292349",129,"8000410042" <i>Note: write location 6 (UCS2 format for the <text> field)</i>	OK <i>Note: Location 6 is written</i>
AT+CPBW=,"+33145221100",145,"SOS" <i>Note: Write at the first location available</i>	OK <i>Note: First location available is written</i>
AT+CPBW="0345221100",129,"SOS" <i>Note: Write at the first location available</i>	+CME ERROR: 20 <i>Note: Phonebook full</i>
AT+CPBW=57,"112",129,"WM" <i>Note: Write at location 57 (wrong)</i>	+CME ERROR: 21 <i>Note: Invalid index</i>
AT+CPBW=7,"012345678901234567890",129,"WAVE" <i>Note: Write at location 7 a phone number exceeding the limit (21 digits)</i>	+CME ERROR: 26 <i>Note: Phone number too long</i>
AT+CPBW=7,"0122334455",129,"TEL" <i>Note: Write at location 7 along text (11 characters)</i>	+CME ERROR: 24 <i>Note: Text too long</i>
AT+CPBW=8,"01292349",129,"80xyz" <i>Note: write location</i>	OK <i>Note: Location 8 is written. The string has a wrong UCS2 format, it is therefore considered as an ASCII string</i>

When the fixed dialing phonebook (FDN) is locked, this command is not allowed. Moreover, when the FDN is unlocked, PIN2 is required to write in the FDN phonebook.

But if PIN2 authentication has been performed during the current session, the +CPBW command with FDN is allowed.

Command	Possible responses
AT+CPBS="FD" <i>Note: Choose FDN</i>	OK
AT+CPBW=5,"01290917",129,"Jacky" <i>Note: Write in FDN at location 5</i>	+CME ERROR: 17 <i>Note: SIM PIN2 is required</i>
AT+CPIN?	SIM PIN2 <i>Note: SIM PIN2 is required</i>
AT+CPIN=5678 <i>Note: Enter SIM PIN2</i>	OK
AT+CPBW=5,"01290917",129,"Jacky" <i>Note: Write in FDN at location 5</i>	OK <i>Note: Writing in FDN is now allowed</i>

Phonebook Phone Search +CPBP

Description:

This command orders the product to search the phonebook for an item with the same phone number as that defined in the parameter.

Values: <PhoneNumber> coded according to GSM 07.07/GSM 07.05

Syntax: AT+CPBP=<PhoneNumber>

Command	Possible responses
AT+CPBP="+331290101" <i>Note: Search entries corresponding to this phone number</i>	+CPBP: 15,"+331290101",145,"Eric" OK <i>Note: Display the entry corresponding to the specified phone number</i>
AT+CPBP="+331290101" <i>Note: Search entries corresponding to this phone number</i>	+CPBP: 15,"01290101",129,"Eric" OK <i>Note: Display the entry corresponding to the specified phone number</i>
AT+CPBP="01290202" <i>Note: Search entries corresponding to this phone number</i>	+CPBP: 15,"+331290202",145,"David" OK <i>Note: Display the entry corresponding to the specified phone number</i>
AT+CPBP="+331288575" <i>Note: Search entries corresponding to this phone number</i>	+CPBP: 15,"+331290101",145,"8045682344FFFF" (UCS2 format) OK <i>Note: Display the entry corresponding to the specified phone number</i>
AT+CPBP="0129" <i>Note: Search entries corresponding to this phone number</i>	+CME ERROR: 22 <i>Note: Entry not found</i>

Move Action in Phonebook +CPBN

Description:

This specific command instructs the product to make a forward or backward move in the phonebook (in alphabetical order). This command is not allowed for the "EN" phonebook - which does not contain alphanumeric fields.

Values:

<mode>

- 0: First item
- 1: Last item
- 2: Next valid item in alphabetical order
- 3: Previous valid item in alphabetical order
- 4: Last item read (usable only if a read operation has been performed on the current phonebook since the end of initialization (+WIND: 4))
- 5: Last item written (usable only if a write operation has been performed on the current phonebook since the end of initialization (+WIND: 4))

Syntax: AT+CPBN=<mode>

Command	Possible responses
AT+CPBN=? <i>Note: Test command</i>	+CPBN: (0-5) OK <i>Note: Possible modes</i>
AT+CPBN=0 <i>Note: Read the first location</i>	+CPBN: 15,"+331290101",145,"Eric" OK <i>Note: Display the first location</i>
AT+CPBN=2 <i>Note: Read the next location</i>	+CPBN: 5,"+33147658987",145,"Frank" OK <i>Note: Display the second location</i>
AT+CPBN=2 <i>Note: Read the next location</i>	+CPBN: 6,"+331290302",145,"Marc" OK <i>Note: Display the third location</i>
AT+CPBN=3 <i>Note: Read the previous location</i>	+CPBN: 5,"+33147658987",145,"Frank" OK <i>Note: Display the second location</i>
AT+CPBN=1 <i>Note: Read the last location</i>	+CPBN: 6,"+331290302",145,"Marc" OK <i>Note: Display the last location</i>
AT+CPBN=2 <i>Note: Read the next location</i>	+CPBP: 15,"+331290101",145,"Eric" OK <i>Note: Display the first location</i>

Using mode 4 and 5 with +CPBF command and CPBW:

Command	Possible responses
AT+CPBF="Er" <i>Note: Find "Er" in phonebook</i>	+CPBF: 15,"+331290101",145,"Eric" OK <i>Note: Display the location</i>
AT+CPBN=2 <i>Note: Read the next location</i>	+CPBF: 5,"+33147658987",145,"Frank" OK <i>Note: Display the following location</i>
AT+CPBF="Er" <i>Note: Find "Er" in phonebook</i>	+CPBF: 15,"+331290101",145,"Eric" OK <i>Note: Display the location</i>
AT+CPBN=4 <i>Note: Get the last location read</i>	+CPBF: 15,"+331290101",145,"Eric" OK <i>Note: Display the last location read</i>
AT+CPBW="0146290800",129,"WM" <i>Note: Write an item at the first location available</i>	OK <i>Note: No information about this location</i>
AT+CPBN=4 <i>Note: Get the last location read</i>	+CPBF: 15,"+331290101",145,"Eric" OK <i>Note: Display the last location read</i>
	AT+CPBN=38,"0146290800,129,"WM" <i>Note: Display the last item written with its location</i>
AT+CPBN=4 <i>Note: Get the last item read</i>	AT+CPBN=38,"0146290800,129,"WM" <i>Note: Now the last item read is the last written item too</i>
AT+CPBF="800041FFFF" <i>Note: Find "800041" in phonebook</i>	+CPBF: 15,"+3312345",145,"8000414339FFFF" OK <i>Note: Display this location</i>
AT+CPBN=4 <i>Note: Get the last location read</i>	+CPBF: 15,"+3312345",145,"8000414339FFFF" OK <i>Note: Display the last location read</i>

Note: The **AT+CPBN=5** command is useful after an **AT+CPBW** command used without a location.

Subscriber Number +CNUM

Description:

This command returns the subscriber MSISDN(s). If the subscriber has different MSISDNs for different services, each MSISDN is returned in a separate line.

Values:

- <alphax>** optional alphanumeric string associated with <numberx>
- <numberx>** string type phone number with format as specified by <typex>
- <typex>** type of address byte in integer format

Command syntax: AT+CNUM

Response syntax: +CNUM: <alpha1>, <number1>, <type1> <CR><LF> +CNUM: <alpha2>, <number2>, <type2>

Command	Possible responses
AT+CNUM <i>Note: Get MSISDN(s)</i>	+CNUM:"Phone", "0612345678",129 +CNUM:"Fax", "0687654321",129 +CNUM: "80001002FFFF", "+0183773", 145 (UCS2 format) OK <i>Note: MSISDNs</i>
AT+CNUM=?	OK

Avoid Phonebook Initialization +WAIP

Description:

This specific command allows the initialization of all phonebooks to be inhibited during subsequent boots.

Values:

<mode>

- 0: Normal initialization (with phonebooks)
- 1: No phonebook initialization

Syntax: AT+WAIP=<mode>

Command	Possible responses
AT+WAIP? <i>Note: Current values ?</i>	+WAIP:0 OK <i>Note: Default value (init phonebooks)</i>
AT+WAIP=? <i>Note: Possible values ?</i>	+WAIP: (0,1) OK <i>Note: Disable / enable</i>
AT+WAIP =1 <i>Note: Inhibit initialization of phonebooks (next boot)</i>	OK <i>Note: no answer</i>
AT&W <i>Note: Save modifications in EEPROM</i>	

Caution: The given value should be stored in EEPROM. Therefore, the AT&W command must be used to save the new <mode> value.

Note: phonebook commands are allowed if +WAIP=1 (after boot). If a phonebook command is entered, a "+CME ERROR: 3" is returned.

Delete Calls Phonebook +WDCP

Description:

This specific command deletes the calls listed in some phonebooks.

Values:

<calls phonebook>

- "LD": SIM (ME extended) Last dialing phonebook
- "MC": ME missed calls list phonebook
- "RC": ME received calls list phonebook

Syntax: +WDCP=<calls phonebook>

Command	Possible responses
AT+WDCP?	OK
AT+WDCP=? <i>Note: Possible values ?</i>	+WDCP: ("LD","MC","RC") OK <i>Note: Identifiers of the phonebooks supporting a list of calls</i>
AT+WDCP="LD" <i>Note: Delete all the content of Last Dialing phonebook.</i>	OK <i>Note: Last Dialing phonebook is now empty.</i>

Set Voice Mail Number +CSVM

Description:

This commands sets/gets and enables/disables the voice mail number in memory..

Values:

<mode>

0: Disable the voice mail number

1: Enable the voice mail number

<number> Phone number in ASCII format.

<type> TON/NPI (Type of address byte in integer format).

Note: For the <type> parameter, all values are allowed from 0 to 255, but the MSB will be set to 1 in all cases (ex: a <type> value of 17 will be written as 145).

Syntax: AT+CSVM=<mode>[,<number>[,<type>]]

Command	Possible responses
AT+CSVM?	+CSVM: 1,"660",129 OK
<i>Note: Get mail number</i>	<i>Note: Voice mail number "660" is activated</i>
AT+CSVM=?	+CSVM: (0-1),(129,145) OK
<i>Note: Possible values ?</i>	<i>Note: activation/deactivation and format 129 & 145 are supported</i>
AT+CSVM=0,"888",129 <i>Note: Disable Voice Mail number and change value to "888".</i>	OK

CHAPTER 9 - SHORT MESSAGES COMMANDS

Parameters Definition

<da>	Destination Address, coded according to the GSM Technical Specification 03.40 TP-DA
<dcs>	Data Coding Scheme, coded according to document [5]
<dt>	Discharge Time in string format: “yy/MM/dd,hh:mm:ss±zz”(Year [00-99], Month [01-12], Day [01-31], Hour, Minute, Second and Time Zone [quarters of an hour])
<fo>	First Byte, coded according to SMS-SUBMIT first byte in document [4], default value is 17 for SMS-SUBMIT
<index>	Place of storage in memory
<length>	Text mode (+CMGF=1): number of characters PDU mode (+CMGF=0): length of the TP data unit in bytes
<mem1>	Memory used to list, read and delete messages (+CMGL, +CMGR and +CMGD)
<mem2>	Memory used to write and send messages (+CMGW, +CMSS)
<mid>	CBM Message Identifier
<mr>	Message Reference
<oa>	Originator Address
<pid>	Protocol Identifier
<pdu>	For SMS : GSM 04.11 SC address followed by GSM Technical Specification 03.40 TPDU in hexadecimal format, coded as specified in doc [4] For CBS : GSM Technical Specification 03.41 TPDU in hexadecimal format
<ra>	Recipient Address
<sca>	Service Center Address
<scts>	Service Center Time Stamp in string format: “yy/MM/dd,hh:mm:ss±zz” (Year/Month/Day,Hour:Min:Seconds±TimeZone)
<sn>	CBM Serial Number
<st>	Status of a SMS-STATUS-REPORT
<stat>	Status of message in memory
<toa>	Type-of-Address of <oa>
<tora>	Type-of-Address of <ra>
<tosca>	Type-of-Address of <sca>
<total1>	Number of message locations in <mem1>
<total2>	Number of messages locations in <mem2>
<used1>	Total number of messages locations in <mem1>
<used2>	Total number of messages locations in <mem2>
<vp>	Validity Period of the short message, default value is 167

Select Message Service +CSMS

Description:

The supported services include originated (SMS-MO) and terminated short messages (SMS-MT) as well as Cell Broadcast Message (SMS-CB) services.

Values:

<service>

0: SMS AT commands are compatible with GSM 07.05 Phase 2 version 4.7.0.

1: SMS AT commands are compatible with GSM 07.05 Phase 2 + version .

Syntax: AT+CSMS=<service>

Command	Possible responses
AT+CSMS=0 <i>Note: SMS AT command Phase 2 version 4.7.0</i>	+CSMS: 1,1,1 OK <i>Note: SMS-MO, SMS-MT and SMS-CB supported</i>
AT+CSMS=1 <i>Note: SMS AT command Phase 2 +</i>	+CSMS: 1,1,1 <i>Note: SMS-MO, SMS-MT and SMS-CB supported</i>
AT+CSMS? <i>Note: Current values ?</i>	+CSMS: 0,1,1,1 OK <i>Note: GSM 03.40 and 03.41 (SMS AT command Phase 2 version 4.7.0)</i>
AT+CSMS=? <i>Note: Possible services</i>	+CSMS: (0,1) OK

New Message Acknowledgement +CNMA

Description:

This command allows reception of a new message routed directly to the TE to be acknowledged.,

In TEXT mode, only positive acknowledgement to the network (RP-ACK) is possible.

In PDU mode, either positive (RP-ACK) or negative (RP-ERROR) acknowledgement to the network is possible.

Acknowledgement with +CNMA is possible only if the +CSMS parameter is set to 1 (+CSMS=1) when a +CMT or +CDS indication is shown (see +CNMI command).

If no acknowledgement occurs within the network timeout, an RP-ERROR is sent to the network. The <mt> and <ds> parameters of the +CNMI command are then reset to zero (do not show new message indication).

Values:

<n>: Type of acknowledgement in PDU mode

0: send RP-ACK without PDU (same as TEXT mode)

1: send RP-ACK with optional PDU message

2: send RP-ERROR with optional PDU message

<length>: Length of the PDU message

Syntax:

Command syntax in text mode: AT+CNMA

Command syntax in PDU mode: AT+CNMA [= <n> [, <length> [<CR>

Note: PDU is entered using <ackpdu> format instead of <pdu> format (e.g., SMSC address field is not present).

PDU is entered <ctrl-Z / ESC>]]]

Example of new message acknowledgement in TEXT mode

Command	Possible responses
AT+CMGF=1 <i>Note: Set TEXT mode</i>	OK <i>Note: TEXT mode valid</i>
AT+CNMI=2,2,0,0,0 <i>Note: <mt>=2</i>	OK
	+CMT: "123456","98/10/01,12:30 00+00",129,4 ,32,240, "15379",129,5<CR><LF> Received message <i>Note: message received</i>
AT+CNMA <i>Note: acknowledge the message received</i>	OK <i>Note: send positive acknowledgement to the network</i>
AT+CNMA <i>Note: try to acknowledge again</i>	+CMS ERROR: 340 <i>Note: no +CNMA acknowledgment expected</i>

Example of new message acknowledgement in PDU mode:

Command	Possible responses
AT+CMGF=0 <i>Note: Set PDU mode</i>	OK <i>Note: PDU mode valid</i>
	+CMT: ,29 07913366003000F1240B913366920547F300000030034 19404800B506215D42ECFE7E17319 <i>Note: message received</i>
AT+CNMA=2,<length> <CR> ... Pdu message ... <Ctrl-Z/ESC> <i>Note: negative acknowledgement for the message.</i>	OK <i>Note: send a negative acknowledgement to the network (RP-ERROR) with PDU message (<ackpdu> format).</i>

Preferred Message Storage +CPMS

Description:

This command allows the message storage area to be selected (for reading, writing, etc).

Values:

<mem1>: Memory used to list, read and delete messages. It can be:

“SM”: SMS message storage in SIM (default)

“BM”: CBM message storage (in volatile memory).

“SR”: Status Report message storage (in SIM if the EF-SMR file exists, otherwise in the ME non volatile memory)

Note: “SR” ME non-volatile memory is cleared when another SIM card is inserted. It is kept, even after a reset, while the same SIM card is used.

<mem2>: Memory used to write and send messages

“SM”: SMS message storage in SIM (default).

If the command is correct, the following message indication is sent:

+CPMS: <used1>,<total1>,<used2>,<total2>

When <mem1> is selected, all following +CMGL, +CMGR and +CMGD commands are related to the type of SMS stored in this memory.

Syntax: AT+CPMS=<mem1>,[<mem2>]

Command	Possible responses
AT+CPMS=? <i>Note: Possible message storages</i>	+CPMS: (("SM","BM","SR"),("SM")) OK <i>Note: Read, list, delete: SMS, CBM or SMS Status Report Write, send: SMS</i>
AT+CPMS? <i>Note: Read</i>	+CPMS: "SM",3, 10,"SM",3,10 OK <i>Note: Read, write...SMS from/to SIM 3 SMS are stored in SIM. 10 is the total memory available in SIM</i>
AT+CPMS="AM" <i>Note: Select false message storage</i>	+CMS ERROR: 302
AT+CPMS="BM" <i>Note: Select CBM message storage</i>	+CPMS: 2,20,3,10 OK <i>Note: Read, list, delete CBM from RAM 2 CBM are stored in RAM</i>
AT+CPMS? <i>Note: Read</i>	+CPMS: "BM",2,20,"SM",3,10 OK <i>Note: Read list, delete CBM from RAM Write SMS to SIM</i>

Preferred Message Format +CMGF

Description:

The message formats supported are *text mode* and *PDU mode*. In PDU mode, a complete SMS Message including all header information is given as a binary string (in hexadecimal format). Therefore, only the following set of characters is allowed: {'0','1','2','3','4','5','6','7','8','9','A','B','C','D','E','F'}. Each pair of characters are converted to a byte (e.g.: '41' is converted to the ASCII character 'A', whose ASCII code is 0x41 or 65). In Text mode, all commands and responses are in ASCII characters. The format selected is stored in EEPROM by the +CSAS command.

Values:

The <pdu> message is composed of the SC address (« 00 means no SC address given, use default SC address read with +CSCA command) and the TPDU message. In this example, the length of **bytes** of the TPDU buffer is 14, coded according to GSM Technical Specification 03.40 . In this case the TPDU is: 0x01 0x03 0x06 0x91 0x21 0x43 0x65 0x00 0x00 0x04 0xC9 0xE9 0x34 0x0B, which is GSM 03.40:

<fo> 0x01 (SMS-SUBMIT, no validity period)
 <mr> (TP-MR) 0x03 (Message Reference)
 <da> (TP-DA) 0x06 0x91 0x21 0x43 0x65 (destination address +123456)
 <pid> (TP-PID) 0x00 (Protocol Identifier)
 <dcs> (TP-DCS) 0x00 (Data Coding Scheme: 7 bits alphabet)
 <length> (TP-UDL) 0x04 (User Data Length, 4 characters of text)
 TP-UD 0xC9 0xE9 0x34 0x0B (User Data: ISSY)

TPDU in hexadecimal format must be converted into two ASCII characters; e.g., an byte with hexadecimal value 0x2A is presented to the ME as two characters '2' (ASCII 50) and 'A' (ASCII 65).

Syntax: AT+CMGF

Command	Possible responses
AT+CMGF ? <i>Note: Current message format</i>	+CMGF: 1 OK <i>Note: Text mode</i>
AT+CMGF=? <i>Note: Possible message format</i>	+CMGF: (0-1) OK <i>Note: Text or PDU modes are available</i>

Example: Sending an SMS Message in PDU mode:

Command	Possible responses
AT+CMGF=0 <i>Note: Set PDU mode</i>	OK <i>Note: PDU mode valid</i>
AT+CMGS=14<CR> 0001030691214365000004C9E9340B <i>Note: Send complete MSG in PDU mode, no SC address</i>	+CMGS: 4 OK <i>Note: MSG correctly sent, <mr> is returned</i>

Save Settings +CSAS

Description:

All settings specified by the +CSCA and +CSMP commands are stored in EEPROM if the SIM card is a Phase 1 card or in the SIM card if it is a Phase 2 SIM card.

Values: No parameters

Syntax: AT+CSAS

Command	Possible responses
AT+CSAS <i>Note: Store +CSCA and +CSMP parameters</i>	OK <i>Note: Parameters saved</i>

Restore Settings +CRES

Description:

All settings specified in the +CSCA and +CSMP commands are restored from EEPROM if the SIM card is Phase 1 or from the SIM card if it is a Phase 2 SIM card.

Values: No parameters

Syntax: AT+CRES

Command	Possible responses
AT+CRES <i>Note: Restore +CSCA and +CSMP parameters</i>	OK <i>Note: Parameters restored</i>

Show Text Mode Parameters +CSDH

Description:

This command gives additional information on text mode result codes. This information is given in brackets in the +CMTI, +CMT, +CDS, +CMGR, +CMGL commands.

Values: <n>: show indicator

0: do not show header values

1: show the values in result codes

Syntax: AT+CSDH

Command	Possible responses
AT+CSDH=0 <i>Note: Set value to "do not how"</i>	OK
AT+CSDH? <i>Note: Current value</i>	+CSDH: 0 OK <i>Note: Do not show header values</i>

New Message Indication +CNMI

Description:

This command selects the procedure for message reception from the network.

Values:

<mode>: controls the processing of unsolicited result codes

Note: Only <mode>=2 is supported.

Any other value for <mode> (0,1 or 3) is accepted (return code will be *OK*), but the processing of unsolicited result codes will be the same as with <mode>=2.

- 0: Buffer unsolicited result codes in the TA. If TA result code buffer is full, indications can be buffered in some other place, or the oldest indications may be discarded and replaced with the new received indications
- 1: Discard indication and reject new received message unsolicited result codes when TA-TE link is reserved. Otherwise forward them directly to the TE
- 2: Buffer unsolicited result codes in the TA when TA-TE link is reserved and flush them to the TE after reservation. Otherwise forward them directly to the TE
- 3: Forward unsolicited result codes directly to the TE. TA-TE link specific inband used to embed result codes and data when TA is in on-line data mode

<mt>: sets the result code indication routing for SMS-DELIVERs. Default is 0.

- 0: No SMS-DELIVER indications are routed.
- 1: SMS-DELIVERs are routed using unsolicited code: +CMTI: "SM",<index>
- 2: SMS-DELIVERs (except class 2 messages) are routed using unsolicited code: +CMT: [<alpha>,
<length> <CR> <LF> <pdu> (PDU mode) or +CMT: <oa>,<alpha>,
<scts> [<tooa>,<fo>,
<pid>,<dcsc>,
<sca>,<tosca>,
<length>] <CR><LF><data> (text mode)
- 3: Class 3 SMS-DELIVERs are routed directly using code in <mt>=2 ; Message of other classes result in indication <mt>=1

<bm>: set the rules for storing received CBMs (Cell Broadcast Message) types depend on its coding scheme, the setting of Select CBM Types (+CSCB command) and <bm>. Default is 0.

- 0: No CBM indications are routed to the TE. The CBMs are stored.
- 1: The CBM is stored and an indication of the memory location is routed to the customer application using unsolicited result code: +CBMI: "BM", <index>
- 2: New CBMs are routed directly to the TE using unsolicited result code. +CBM: <length><CR><LF><pdu> (PDU mode) or +CBM:<sn>,<mid>,<dcsc>,<page>,<pages>(Text mode) <CR><LF> <data>
- 3: Class 3 CBMs: as <bm>=2. Other classes CBMs: as <bm>=1.

<ds> for SMS-STATUS-REPORTs. Default is 0.

- 0: No SMS-STATUS-REPORTs are routed.
- 1: SMS-STATUS-REPORTs are routed using unsolicited code: +CDS: <length> <CR> <LF> <pdu> (PDU mode) or +CDS: <fo>,<mr>,
[<ra>] , [<tora>],
<scts>,<dt>,
<st> (Text mode)
- 2: SMS-STATUS-REPORTs are stored and routed using the unsolicited result code: +CDSI: "SR",<index>

<bfr> Default is 0.

- 0: TA buffer of unsolicited result codes defined within this command is flushed to the TE when <mode> 1...3 is entered (OK response shall be given before flushing the codes)
- 1: TA buffer of unsolicited result codes defined within this command is cleared when <mode> 1...3 is entered.

Syntax: AT+CNMI=<mode>,<mt>,<bm>,<ds>,<bfr>

Command	Possible responses
AT+CNMI=2,1,0,0,0 <i>Note: <mt>=1</i>	OK
	AT+CMTI: "SM",1 <i>Note: message received</i>
AT+CNMI=2,2,0,0,0 <i>Note: <mt>=2</i>	OK
	+CMT: "123456","98/10/01,12:30 00+00",129,4,32,240, "15379",129,5<CR><LF> <i>Note: message received</i>
AT+CNMI=2,0,0,1,0 <i>Note: <ds>=1</i>	OK
AT+CMGS="+33146290800"<CR> Message to send <ctrl-Z> <i>Note: Send a message in text mode</i>	+CMGS: 7 OK <i>Note: Successful transmission</i>
	+CDS: 2, 116, "+33146290800", 145, "98/10/01,12:30:07+04", "98/10/01 12:30:08+04", 0 <i>Note: message was correctly delivered</i>

Read Message +CMGR

Description:

This command allows the application to read stored messages. The messages are read from the memory selected by the **+CPMS** command.

Command syntax: AT+CMGR=<index>

Response syntax for text mode:

+CMGR: <stat>, <oa>, [<alpha>], <scts> [, <tooa>, <fo>, <pid>, <dcs>, <sca>, <tosca>, <length>] <CR><LF> <data> (for **SMS-DELIVER** only)

+CMGR: <stat>, <da>, [<alpha>], [, <toda>, <fo>, <pid>, <dcs>, [, <vp>], <sca>, <tosca>, <length>] <CR><LF> <data> (for **SMS-SUBMIT** only)

+CMGR: <stat>, <fo>, <mr>, [<ra>], [<tora>], <scts>, <dt>, <st> (for **SMS-STATUS-REPORT** only)

Response syntax for PDU mode:

+CMGR: <stat>, [<alpha>], <length> <CR><LF> <pdu>

A message read with status "REC UNREAD" will be updated in memory with the status "REC READ".

Note: The <stat> parameter for SMS Status Reports is always "READ".

Command	Possible responses
	AT+CMTI: "SM",1 <i>Note: New message received</i>
AT+CMGR=1 <i>Note: Read the message</i>	+CMGR: "REC UNREAD", "0146290800", "98/10/01,18:22:11+00", <CR><LF> ABCdefGHI OK
AT+CMGR=1 <i>Note: Read the message again</i>	+CMGR: "REC UNREAD", "0146290800", "98/10/01,18:22:11+00", <CR><LF> ABCdefGHI OK <i>Note: Message is read now</i>
AT+CMGR=2 <i>Note: Read at a wrong index</i>	+CMS ERROR: 321 <i>Note: Error: invalid index</i>
AT+CMGF=0 ;+CMGR=1 <i>Note: In PDU mode</i>	+CMGR: 2,, <length> <CR><LF><pdu> OK <i>Note: Message is stored but unsent, no <alpha>field</i>
AT+CMGF=1;+CPMS="SR";+CNMI=,,2 Reset to text mode, set read memory to "SR", and allow storage of further SMS Status Report into "SR" memory	OK
AT+CMSS=3 Send an SMS previously stored	+CMSS: 160 OK
	+CDSI: "SR",1 New SMS Status Report stored in "SR" memory at index 1
AT+CMGR=1 Read the SMS Status Report	+CMGR: "READ",6,160, "33612345678",129,"01/05/31,15:15:09+00", "01/05/31,15:15:09+00",0 OK

List Message +CMGL

Description:

This command allows the application to read stored messages, by indicating the type of the message to read. The messages are read from the memory selected by the +CPMS command.

Values:

<stat> possible values (status of messages in memory):

Text mode possible values	PDU mode possible values	Status of messages in memory
"REC UNREAD"	0	received unread messages
"REC READ"	1	received read messages
"STO UNSENT"	2	stored unsent messages
"STO SENT"	3	stored sent messages
"ALL"	4	all messages

Note: For SMS Status Reports, only "ALL" / 4 and "READ" / 1 values of the <stat> parameter will list messages ; other values will only return OK.

Command syntax: AT+CMGL=<stat>

Response syntax for text mode:

+CMGL: <index>,<stat>,<da/oa>[,<alpha>], [<scts>, <tooa/toda>, <length>] <CR><LF><data> (for **SMS-DELIVER** and **SMS-SUBMIT**, may be followed by other <CR><LF>+CMGL:<index>...)

+CMGL: <index>,<stat>,<fo>,<mr>,[<ra>],[<tora>],<scts>,<dt>,<st> (for **SMS-STATUS-REPORT** only, may be followed by other <CR><LF>+CMGL:<index>...)

Response syntax for PDU mode:

+CMGL: <index>,<stat>, [<alpha>], <length> <CR><LF> <pdu> (for **SMS-DELIVER**, **SMS-SUBMIT** and **SMS-STATUS-REPORT**, may be followed by other <CR><LF>+CMGL:<index>...)

Command	Possible responses
AT+CMGL="REC UNREAD" <i>Note: List unread messages in text mode</i>	+CMGL: 1,"REC UNREAD","0146290800", <CR><LF> Unread message ! +CMGL: 3,"REC UNREAD", "46290800", <CR><LF> Another message unread! OK <i>Note: 2 messages are unread, these messages will then have their status changed to "REC READ" (+CSDH:0)</i>
AT+CMGL="REC READ" <i>Note: List read messages in text mode</i>	+CMGL: 2,"REC READ","0146290800", <CR><LF> Keep cool OK
AT+CMGL="STO SENT" <i>Note: List stored and sent messages in text mode</i>	OK <i>Note: No message found</i>
AT+CMGL=1 <i>Note: List read messages in PDU mode</i>	+CMGL: 1,1,,26 <CR><LF> 07913366003000F3040B913366920547F4001300119041253 0400741AA8E5A9C5201 OK

Send Message +CMGS

Description:

The <address> field is the address of the terminal to which the message is sent. To send the message, simply type, <ctrl-Z> character (ASCII 26). The text can contain all existing characters except <ctrl-Z> and <ESC> (ASCII 27). This command can be aborted using the <ESC> character when entering text. In PDU mode, only hexadecimal characters are used ('0'...'9','A'...'F').

Values: <ctrl-Z / ESC > type this to send the message

Command syntax in text mode:

AT+CMGS= <da> [,<toda>] <CR>

text is entered <ctrl-Z / ESC >

Command syntax in PDU mode:

AT+CMGS= <length> <CR>

PDU is entered <ctrl-Z / ESC >

Command	Possible responses
AT+CMGS="+33146290800"<CR> Please call me soon, Fred. <ctrl-Z> <i>Note: Send a message in text mode</i>	+CMGS: <mr> OK <i>Note: Successful transmission</i>
AT+CMGS=<length><CR><pdu><ctrl-Z> <i>Note: Send a message in PDU mode</i>	+CMGS: <mr> OK <i>Note: Successful transmission</i>

The message reference <mr> is returned to the application and allocated by the product. This number begins with 0, is incremented by one for each outgoing message (successes and failures), and is cyclic on one byte (0 follows 255). **Note:** This number is not a storage number. Outgoing messages are not stored.

Write Message to Memory +CMGW

Description:

This command stores a message in memory (either SMS-SUBMIT or SMS-DELIVERs). The memory location <index> is returned (no choice possible as with phonebooks +CPBW). Text or PDU is entered as described for the Send Message +CMGS command.

Values:

<oa/da>: Originating or Destination Address Value in string format

<tooa/toda>: Type of Originating / Destination Address

<stat>: Integer type in PDU mode (*default 2 for +CMGW*) or string type in text mode (*default "STO UNSENT" for +CMGW*). Indicates the status of message in memory. If <stat> is omitted, the stored message is considered as a message to send

<stat>

0: "REC UNREAD"

1: "REC READ"

2: "STO UNSENT"

3: "STO SENT"

<length>: Length of the actual data unit in bytes

Command syntax in text mode: (<index> is returned in both cases)

AT+CMGW= <oa/da> [,<tooa/toda> [,<stat>]] <CR>

enter text <ctrl-Z / ESC>

Command syntax in PDU mode:

AT+CMGW= <length> [,<stat>] <CR>

give PDU <ctrl-Z / ESC>

Response syntax:

+CMGW: <index> or **+CMS ERROR:** <err> if writing fails

Command	Possible responses
AT+CMGW="+33146290800"<CR> Hello how are you ?<ctrl-Z> <i>Note: Write a message in text mode</i>	+CMGW: 4 OK <i>Note: Message stored in index 4</i>
AT+CMGW=<length><CR><pdu><ctrl-Z> <i>Note: Write a message in PDU mode</i>	+CMGW: <index> OK <i>Note: Message stored in <index></i>

Send Message from Storage +CMSS

Description:

This command sends a message stored at location value <index>.

Values:

<index> location of stored message
 <da> desination address
 <tda> type of destination address
 <mr> message reference

Command syntax: **AT+CMSS=<index>[,<da> [,<tda>]]**

Response syntax: **+CMSS: <mr>** or **+CMS ERROR: <err>** if sending fails

If a new recipient address <da> is given, it will be used instead of the one stored with the message

Command	Possible responses
AT+CMGW=0660123456<CR> Today is my birthday <i>Note:</i>	+CMGW: 5 OK <i>Note: Message stored with index 5</i>
AT+CMSS=5, 0680654321 <i>Note: Send the message 5 to a different destination number</i>	AT+CMSS:<mr> OK <i>Note: Successful transmission</i>
AT+CMSS=5, 0680654321 <i>Note: Send the message 5 to a different destination number</i>	+CMSS:<mr> OK <i>Note: Successful transmission</i>

Set Text Mode Parameters +CSMP

Description:

This command selects a value for <vp>, <pid>, and <dc>.

Values:

The <fo> byte comprises 6 different fields:

B7	B6	B5	b4	b3	b2	b1	b0
RP	UDHI	SRR	VPF		RD	MTI	

RP: Reply Path, not used in text mode.

UDHI: User Data Header Information, b6=1 if the beginning of the User Data field contains a Header in addition to the short message. This option is not supported in +CSMP command, but can be used in PDU mode (+CMGS).

SRR: Status Report Request, b5=1 if a status report is requested. This mode is supported.

VPF: Validity Period Format

b4=0 & b3=0 -> <vp> field is not present

b4=1 & b3=0 -> <vp> field is present in relative format

Others formats (absolute & enhanced) are not supported.

RD: Reject Duplicates, b2=1 to instruct the SC to reject an SMS-SUBMIT for an SM still held in the SC which has the same <mr> and the same <da> as the previously submitted SM from the same <oa>.

MTI: Message Type Indicator

b1=0 & b0=0 -> SMS-DELIVER (in the direction SC to MS)

b1=0 & b0=1 -> SMS-SUBMIT (in the direction MS to SC)

In text mode <vp> is only coded in "relative" format. The default value is 167 (24 hours). This means that one byte can describe different values:

VP value	Validity period value
0 to 143	(VP + 1) x 5 minutes (up to 12 hours)
144 to 167	12 hours + ((VP - 143) x 30 minutes)
168 to 196	(VP - 166) x 1 day
197 to 255	(VP - 192) x 1 week

<pid> is used to indicate the higher layer protocol being used or indicates interworking with a certain type of telematic device. For example, 0x22 is for group 3 telefax, 0x24 is for voice telephone, 0x25 is for ERMES.

<dc> is used to determine the way the information is encoded. Compressed text is not supported. Only GSM default alphabet, 8 bit data and UCS2 alphabet are supported.

Syntax: AT+CSMP=<fo>, <vp>, <pid>,<dc>

Command	Possible responses
AT+CSMP? <i>Note: current values</i>	+CSMP: 0,0,0,0 OK <i>Note: No validity period</i> <i><dc>= PCCP437 alphabet (8 bits → 7 bits)</i>
AT+CMPS=17,23,64,244 <i>Note:<vp> = 23 (2 hours, relative format)</i> <i><dc> = GSM 8 bits alphabet</i>	OK <i>Note: Command correct</i>

Delete Message +CMGD

Description:

This command deletes one or several messages from preferred message storage (“BM” SMS CB ‘RAM storage’, “SM” SMSPP storage ‘SIM storage’ or “SR” SMS Status-Report storage).

Values:

<index>

(1-20)

When the preferred message storage is “BM” Integer type values in the range of location numbers of SIM Message memory when the preferred message storage is “SM” or “SR”.

<DelFlag>

- 0 Delete message at location <index>.
- 1 Delete All READ messages
- 2 Delete All READ and SENT messages
- 3 Delete All READ, SENT and UNSENT messages
- 4 Delete All messages.

Note: When the preferred message storage is “SR”, as SMS status reports are assumed to have a “READ” status, if <DelFlag> is greater than 0, all SMS status reports will be deleted.

Syntax: AT+CMGD=<Index> [,<DelFalg>]

Command	Possible responses
	+CMTI:”SM”,3 <i>Note: New message received</i>
AT+CMGR=3 <i>Note: Read it</i>	+CMGR: ”REC UNREAD”,”0146290800”, ”98/10/01,18:19:20+00” <CR><LF> Message received! <i>Note: Unread message received from 0146290800 on the 01/10/1998 at 18H19m 20s</i>
AT+CMGD=3 <i>Note: Delete it</i>	OK <i>Note: Message deleted</i>
AT+CMGD=1,0	OK <i>Note: The message from the preferred message storage at the location 1 is deleted</i>
AT+CMGD=1,1	OK <i>Note: All READ messages from the preferred message storage are deleted</i>
AT+CMGD=1,2	OK <i>Note: All READ messages and SENT mobile originated messages are deleted</i>
AT+CMGD=1,3	OK <i>Note: All READ, SENT and UNSENT messages are deleted</i>
AT+CMGD=1,4	OK <i>Note: All messages are deleted</i>

Service Center Address +CSCA

Description

This command indicates the service center to which the message must be sent. The product has no default value for this address. If the application tries to send a message without having indicated the service center address, an error will be generated. Therefore, the application must indicate the SC address when initializing the SMS. This address is then permanently valid. The application may change it if necessary.

Values:

<sca> service center address

Syntax: AT+CSCA

Command	Possible responses
AT+CMGS= "+33146290800"<CR> Hello, how are you?<ctrl-Z> <i>Note: Send a message</i>	+CMS ERROR: 330 <i>Note: service center unknown</i>
AT+CSCA="0696741234" <i>Note: Service center initialization</i>	OK
AT+CMGS="+33146290800"<CR> Happy Birthday ! <ctrl-Z> <i>Note:</i>	+CMGS: 1 OK <i>Note: Successful transmission</i>

Select Cell Broadcast Message Types +CSCB

Description:

This command selects which types of CBMs are to be received by the ME. This command is allowed in both PDU and text modes.

Values:

The <bm> parameter of +CNMI command controls the message indication.

The activation of **CBM reception (<mode>=0)** can select only specific **Message Identifiers (list in <mids>)** for specific **Languages (list in <dcss>)**, but the deactivation stops any reception of CBMs (only AT+CSCB=1 is allowed).

Message Identifiers (<mids> parameter) indicates the type of message identifiers for which the ME should listen.

<dcss> Supported languages

0 for German	8 for Portuguese
1 for English	9 for Finnish
2 for Italian	10 for Norwegian
3 for French	11 for Greek
4 for Spanish	12 for Turkish
5 for Dutch	13 for Hungarian
6 for Swedish	14 for Polish
7 for Danish	32 for Czech

Syntax: AT+CSCB= <mode>, [<mids>, [<dcss>]]

Important Note : Test read command (AT+CSCB ? is not supported).

Command	Possible responses
AT+CSCB=0,"15-17,50,86","" <i>Note: Accept SMS-CB types, 15,16,17,50 and 86 in any language</i>	OK <i>Note: CBMs can be received</i>
	+CBM: 10<CR><LF> 00112233445566778899 <i>Note: CBM length of a received Cell Broadcast message (SMS-CB), CBM bytes in PDU mode</i>
AT+CSCB=1 <i>Note: Deactivate the reception of CBMs</i>	OK <i>Note: CBM reception is completely stopped</i>

Cell Broadcast Message Identifiers +WCBM

Description:

This specific command is used to read the EF-CBMI SIM file. The EF-CBMI file is not used with the +CSCB command. The application should read this file (using AT+WCBM ?) and combine the Message Identifiers with those required by the application.

Values:

<mids> message identifiers

Syntax: AT+WCBM= <mids>

Command	Possible responses
AT+WCBM="10,100,1000,10000" <i>Note : Write 4 messages identifiers in EFCBMI</i>	OK <i>Note : CBMIs</i>
AT+WCBM? <i>Note : Read the CBMIs in EF-CBMI</i>	+WCBM="10,100,1000,10000" OK <i>Note : 4 CBMIs are stored in EF-CBMI</i>

Message Status Modification +WMSC

Description:

This command allows the manipulation of a message status. The accepted status changes are from READ to NOT READ and vice versa, and also from SENT to NOT SENT and vice versa.

Values:

<loc> location number of the stored message <integer>

<status> new status to be stored, as in the +CMGL command

PDU Mode	Text Mode
0	"REC UNREAD"
1	"REC READ"
2	"STO UNSENT"
3	"STO SENT"

Syntax: AT+WMSC= <loc>, <status>

Command	Possible responses
AT+CMGR=2	+CMGR: "REC READ", "+336290918", "99/05/01 14:19:44+04" <CR><LF> Hello All of you! OK
AT+WMSC=2, "REC UNREAD"	
AT+CMGR=2	+CMGR: "REC UNREAD", "+336290918", "99/05/01 14:19:44+04" <CR><LF> Hello All of you! OK

Note: If all parameters are correct, the product overwrites the whole SMS in SIM. Only the first byte (Status byte) is changed.

Possible responses:

OK if the location is valid

+CMS ERROR: 321 if <loc> is invalid or free

+CMS ERROR: 302 if the new <status> and the previous one are incompatible (1)

Message Overwriting +WMGO

Description:

The +CMGW command writes an SMS to the first location available. To write an SMS to a specified location, the +WMGO command forces the product to write an SMS (with the +CMGW command) to the location specified with +WMGO, but for just one +CMGW command.

Important Notes:

- If the external application specifies a free location and an incoming message is received before the AT+CMGW command occurs, the product may store the incoming message at the specified available location. If the user then issues an AT+CMGW command without changing the location with another AT+WMGO, the received message will be overwritten.
- The location number is not kept over a software reset.

Values:

<loc> location number of the SIM record to write or overwrite. The number depends on the SIM capacity.

Syntax: AT+WMGO= <loc>

Command	Possible responses
AT+CMGW="+33146290800"<CR> Hello how are you?<ctrl-Z> <i>Note: Write a message in text mode</i>	+CMGW: 4 OK <i>Note: Message stored in index 4</i>
AT+WMGO=4	
AT+CMGW="+33146299704"<CR> You are overwritten<ctrl-Z>	+CMGW: 4 OK <i>Note: New Message stored in index 4</i>
AT+WMGO?	+WMGO: 4 OK
AT+WMGO=999	+CMS ERROR:321
AT+WMGO=?	+WMGO: [<range of location>] OK

Unchange SMS Status +WUSS

Description:

The +WUSS command allows the SMS Status to be kept at UNREAD after +CMGR or +CMGL.

Values:

<mode>

- 0 The SMS Status will change
- 1 The SMS Status will not change

Syntax: AT+WUSS = <mode>

Command	Possible responses
AT+WUSS=1	OK
	+CMTI: "SM",10 Note: SMS has been received in index 10
AT+CMGR=10	+CMGR: "REC UNREAD","+33660669023",,"03/02/ 13, 18:36:35+00"<CR><LF> Do you want to change state?
	OK
AT+CMGR=10	+CMGR: "REC UNREAD ,"+33660669023",,"03/02/ 13, 18:36:35+00"<CR><LF> Do you want to change state?
	OK Note: The state hasn't been updated
AT+WUSS=0	OK
AT+CMGR=10	+CMGR: "REC UNREAD","+33660669023",,"03/02/ 13, 18:56:55+00"<CR><LF> It is me again.
	OK
AT+CMGR=10	+CMGR: "REC READ","+33660669023",,"03/02/ 13, 18:56:55+00"<CR><LF> It is me again.
	OK

CHAPTER 10 – SUPPLEMENTARY SERVICES COMMANDS

Call Forwarding +CCFC

Description:

This commands allows control of the "call forwarding" supplementary service..

Values:

<reason>

- 0 Unconditional
- 1 Mobile busy
- 2 No reply
- 3 Not reachable
- 4 All call forwarding
- 5 All conditional call forwarding

<mode>

- 0 Disable
- 1 Enable
- 2 Interrogate
- 3 Registration
- 4 Erasure

<type> TON/NPI (Type of address byte in integer format) (default 145 when dialing string includes international access code character "+"; otherwise, 129).

<class>

- 1 Voice
- 2 Data
- 3 Fax
- 4 Short Messages
- 5 All classes

Note: The combination of different classes is not supported, it will only result in the activation / deactivation / status request of all classes (7).

In the case where the FDN phonebook is activated, the registration is restricted to the phone numbers written in the FDN.

If <Class> parameter is not given in the command, 7 is used as the default value.

<subaddr> not managed

<satype> not managed

<time> For <reason> = 2 (No reply), 4 (all call forwarding) and 5 (all conditional call forwarding), time to wait (1 to 30) in seconds before call is forwarded. Default value is 20.

<status>

- 0: not active
- 1: active

Command syntax: AT+CCFC= <reason>, <mode> [, <number> [,<type> [,<class> [,<subaddr> [, <satype> [,<time>]]]]]]

Response syntax: +CCFC: <status>, <class1> [, <number>, <type> [,<subaddr>, <satype> [,<time>]]]] [<CR><LF>+CCFC: <status>, <class2> [, <number>, <type> [,<subaddr>, <satype> [,<time>]]]] [...]

Command	Possible responses
AT+CCFC=0,3,"0146290800" <i>Note: Register to an unconditional call forwarding</i>	OK <i>Note: Command valid</i>
AT+CCFC=0,2 <i>Note: Interrogate unconditional call forwarding</i>	+CCFC:1,1,"0146290800",129 <i>Note: Call forwarding active for voice</i> <CR><LF>+CCFC:1,2,"0146290802",129 <i>Note: Call forwarding active for data</i> <CR><LF>+CCFC:1,4,"0146290804",129 OK <i>Note: Call forwarding active for fax</i>
AT+CCFC=0,4 <i>Note: Erase unconditional call forwarding</i>	OK <i>Note: Command valid</i>

+CCFC responses are not sorted by <class> parameter, but only by the order of network response.

Call Barring +CLCK

Description:

This command allows control of the call barring supplementary service. Locking, unlocking or querying the status of call barring is possible for all classes or for a specific class.

Values:

<fac>

“AO”, “OI”, “OX” barring outgoing calls
 “AI”, “IR” barring incoming calls
 “AG”, “AC”, “AB” barring all calls (<mode>=0 only)

<mode>

0 Unlocks the facility
 1 Locks the facility
 2 Query status

<class>

See description for the +CLCK command (Facility Lock) or +CCFC (Call forwarding).
 Note: A combination of different classes is not supported. It will only result in the activation/deactivation/status_request for all classes (7).

<status>

0 Not active
 1 Active

Command Syntax: AT+CLCK= <fac>, <mode> [, <password> [, <class>]]

Response Syntax: +CLCK: <status> [, <class1> [<CR><LF>+CLCK: <status>, <class2> [...]]
 (for <mode>=2 and command successful)

Command	Possible responses
AT+CLCK="AO",1,1234	OK <i>Note: Command valid</i>
AT+CLCK="AO",0,5555	+CME ERROR: 16 <i>Note: Wrong password</i>
AT+CLCK="AO",0,1234	OK <i>Note: Command valid</i>

Modify SS Password +CPWD

Description:

This command changes the supplementary service password.

Values:

<fac> See +CLCK command with only “P2” facility added (SIM PIN2).

Note: Regardless of the specified facility, the change of password applies to *barring all calls*.

<OldPassword>, (NewPassword) The password code is over 8 digits for P2 facility (4 to 8 digits)

The password code is over 4 digits for other facilities (1 to 4 digits)

Syntax: AT+CPWD=<fac>,<OldPassword>, <NewPassword>

Command	Possible responses
AT+CPWD="AO",1234,5555 <i>Note: Change Call Barring password</i>	OK <i>Note: Password changed</i>
AT+CPWD="AO",1234,5555 <i>Note: Change password</i>	+CME ERROR: 16 <i>Note: Wrong password</i>
AT+CPWD="AO",5555,1234 <i>Note: Change password</i>	OK <i>Note: Password changed</i>

Call Waiting +CCWA

Description:

This command controls the call waiting supplementary service. The product will send a +CCWA unsolicited result code when the call waiting service is enabled.

Values:

<n>: result code presentation status in the TA

- 0: Disable
- 1: Enable

<mode>

- 0: Disable
- 1: Enable
- 2: Query status

<class>

- 1: Voice
- 2: Data
- 4: Fax
- 8: Short Messages
- 7: All classes (voice, data, and fax)

Note: A combination of different classes is **not supported**. It will only result in the activation / deactivation / status request for all classes (7).

<status>

- 0: Not Active
- 1: Active

<alpha>: Optional string type alphanumeric representation of <number> corresponding to the entry found in the ADN or FDN phonebook.

Command Syntax: AT+CCWA=<n>, [<mode> [, <class>]]

Response Syntax: +CCWA: <status> [, <class1> [<CR><LF>+CCWA: <status>, <class2> [...]]
(for <mode>=2 and command successful)

Unsolicited Result: +CCWA: <number>, <type>, <class> [,<alpha>] (when waiting service is enabled)

Command	Possible responses
AT+CCWA=1,1,1 <i>Note: Enable call waiting for voice calls</i>	OK <i>Note: Command valid</i>
AT+CCWA=1,2 <i>Note: Interrogate call waiting</i>	+CCWA:1,1 OK <i>Note: Call waiting active for voice calls</i>
	+CCWA:"0146290800",145,1,"FREDDY" or +CCWA:"0146290800",145,1,"8023459678FFFF" (UCS2 format) <i>Note: Number and name of the waiting voice call</i>
AT+CCWA=1,0,7 <i>Note: Erase call waiting</i>	OK <i>Note: Command valid</i>
	+CCWA:,,1 <i>Note: voice call waiting (no number)</i>

Calling Line Identification Restriction +CLIR

Description:

This command controls the Calling Line Identification restriction supplementary service.

Values:

- <n>** Sets the line ID restriction for outgoing calls
- 0: Presentation indicator is used according to the subscription of the CLIR service
 - 1: CLIR invocation
 - 2: CLIR suppression
- <m>**: Shows the subscriber CLIR status in the network
- 0: CLIR not provisioned
 - 1: CLIR provisioned in permanent mode
 - 2: Unknown (no network...)
 - 3: CLIR temporary mode presentation restricted
 - 4: CLIR temporary mode presentation allowed

Command syntax: AT+CLIR=<n>

Response syntax: +CLIR:<n>,<m> (for AT+CLIR ?)

Command	Possible responses
AT+CLIR=2	OK <i>Note: Command valid</i>
AT+CLIR ? <i>Note: Ask for current functionality</i>	+CLIR:<n>,<m> OK <i>Note: <n> and <m> as defined above</i>

Calling Line Identification Presentation +CLIP

Description:

This command controls the calling line identification presentation supplementary service. When presentation of the CLI (Calling Line Identification) is enabled (and calling subscriber allows), +CLIP response is returned after every RING (or +CRING) result code.

Values:

- <n>:** Parameter sets/shows the result code presentation in the TA
- 0:** Disable
 - 1:** Enable
- <m>:** parameter shows the subscriber CLIP service status in the network
- 0:** CLIP not provisioned
 - 1:** CLIP provisioned
 - 2:** Unknown (no network...)

Command syntax: AT+CLIP=<n>

Response syntax:

+CLIP: <n>,<m> (as response to AT+CLIP)

+CLIP: <number>, <type>[,<subaddr>, <satype>, <alpha>] (for an incoming call, after each RING or +CRING indication)

Command	Possible responses
AT+CLIP=1 <i>Note: Enable CLIP</i>	OK <i>Note: CLIP is enabled</i>
AT+CLIP? <i>Note: Ask for current functionality</i>	+CLIP:<n>,<m> OK <i>Note: <n> and <m> defined as below</i>
	RING <i>Note: Incoming call</i> +CLIP: "0146290800",129,1,,,"FRED" <i>Note: Incoming call with number and name presentation</i>
	RING <i>Note: Incoming call</i> +CLIP: "0146290800",129,1,, "8000204212FFFF" <i>Note: Incoming call with number and name presentation (UCS2 format)</i>
AT+CLIP=0 <i>Note: Disable CLIP presentation</i>	OK <i>Note: Command valid</i>

Connected Line Identification Presentation +COLP

Description:

This command controls the connected line identification presentation supplementary service - useful for call forwarding of the connected line.

Values:

- <n>:** Parameter sets/shows the result code presentation **status** in the TA
- 0:** Disable
 - 1:** Enable
- <m>:** Parameter shows the subscriber COLP service **status** in the network
- 0:** COLP not provisioned
 - 1:** COLP provisioned
 - 2:** Unknown (no network)

Command syntax: **AT+COLP=<n>**

Response syntax: **+COLP: <n>,<m>** (as response to AT+COLP?)

+COLP: <number>,<type> [,<subaddr>, <satype>, <alpha>]

After ATD command, before OK or CONNECT <speed>

Command	Possible responses
AT+COLP=1 <i>Note: Activate COLP</i>	OK <i>Note: Command valid</i>
AT+COLP? <i>Note: Ask for current functionality</i>	+COLP:1,1 OK <i>Note: COLP is enabled and provisioned</i>
ATD146290928; <i>Note: Outgoing call</i>	+COLP:"0146290928",129,,,"JOE" or +COLP:"0146290800",129,1,,,"8000204212FFFF" (UCS2 format) OK <i>Note: Connected outgoing line number and name presentation</i>
AT+COLP=0 <i>Note: Deactivate COLP</i>	OK <i>Note: Command valid</i>

Advice of Charge +CAOC

Description:

This refers to the Advice of Charge supplementary service (GSM 02.24 and GSM 02.86), which enables the subscriber to obtain information on call cost. With <mode>=0, the command returns the current call meter value (CCM) from the ME.

If AOC is supported, the command can also enable unsolicited event reporting on CCM information.

The unsolicited result code +CCCM: <ccm> is sent when the CCM value changes. Deactivation of unsolicited event reporting is performed with the same command.

If AOC is supported, the Read command indicates whether unsolicited reporting is activated or not.

Values:

<mode>

- 0: Query CCM value
- 1: Deactivate the unsolicited reporting of CCM value
- 2: Activate the unsolicited reporting of CCM value

<ccm> String type; three bytes of the current call meter value in hexadecimal format (e.g. "00001E" corresponds to the decimal value 30); value is in home units and bytes are coded in a similar way as the ACMmax value in SIM

Command syntax: AT+CAOC= <mode>

Command	Possible responses
AT+CAOC=0 <i>Note: Query CCM value</i>	+CAOC: "000A08" OK <i>Note: Display Current Call Meter value (CCM=2568)</i>
AT+CAOC=1 <i>Note: Deactivate unsolicited report of CCM value</i>	OK <i>Note: CCM report deactivated</i>
AT+CAOC=2 <i>Note: Activate unsolicited report of CCM value</i>	OK <i>Note: CCM report activated</i>
AT+CAOC ? <i>Note: Request mode</i>	+CAOC:<mode> OK <i>Note: Display unsolicited report mode (1 or 2)</i>
AT+CAOC=? <i>Note: Request supported modes</i>	+CAOC: (0-2) OK <i>Note: 0,1,2 modes supported</i>

Accumulated Call Meter +CACM

Description:

This command resets the Advice of Charge for accumulated call meter value in SIM file EF_{ACM}. The ACM contains the total number of home units for both the current and preceding calls. SIM PIN2 is required to reset the value. If setting fails in an ME error, +CME ERROR: <err> is returned. The Read command returns the current value of the ACM. The ACM value (entered or displayed) is in hexadecimal format with 6 digits.

Values:

- <pin2 passwd> string type
- <acm value> string type coded as <ccm> under +CAOC

Command Syntax: AT+CACM

Command	Possible responses
AT+CACM? <i>Note: Request ACM value</i>	+CACM: "000400" OK <i>Note: Display ACM value (ACM=1024)</i>
AT+CACM= 1234 <i>Note: Request ACM reset, real PIN2 is "1234"</i>	OK <i>Note: ACM value is reset</i>
AT+CACM= 0000 <i>Note: Request ACM reset with wrong PIN2 value</i>	+CME ERROR: 16 <i>Note: Incorrect password</i>
AT+CACM ? <i>Note: Request ACM value</i>	+CACM: "000000" OK <i>Note: Display ACM value (ACM = 0)</i>

Accumulated Call Meter Maximum +CAMM

Description:

The set command sets the Advice of Charge related to accumulated call meter maximum value in SIM file EF_{ACMmax}. ACMmax contains the maximum number of home units the subscriber is allowed to consume. When ACM (see +CACM) reaches ACMmax, calls are prohibited. SIM PIN2 is required to set the value. If setting fails in an ME error, +CME ERROR: <err> is returned.

The Read command returns the current value of ACMmax.

The ACMmax value (entered or displayed) is in hexadecimal format with 6 digits.

Values:

<ACMmax> String type coded as <CCM> under +CAOC. Value 0 disables ACMmax feature.

<pin2 passwd> String type

Command syntax: AT+CAMM:<ACMmax>,<pin2 passwd>

Command	Possible responses
AT+CAMM="000400",1234 <i>Note: Request ACMmax update, PIN2 is "1234"</i>	OK <i>Note: ACMmax updated to 1024</i>
AT+CAMM="000400",0000 <i>Note: Request ACMmax update, PIN2 is "1234"</i>	+CME ERROR: 16 <i>Note: Incorrect password</i>
AT+CAMM ? <i>Note: Request ACMmax value</i>	+CAMM: "000400" OK <i>Note: ACMmax = 1024</i>

Price Per Unit and Currency Table +CPUC

Description:

The set command sets the parameters for Advice of Charge related to price per unit and the currency table in SIM file EF_{PUCT}. PUCT information can be used to convert the home units (as used in +CAOC, +CACM and +CAMM) into currency units. SIM PIN2 is required to set the parameters. If setting fails in an ME error, +CME ERROR: <err> is returned..

Values:

<currency> String type

<ppu> String type

<pin2 passwd> String type

Command syntax: AT+CPUC <currency>,<ppu>,<pin2 passwd>

Command	Possible responses
AT+CPUC="FFR","0.82",1234 <i>Note: Request Currency and Price per unit update</i>	OK
AT+CPUC="FFR","0.82",1111 <i>Note: Request Currency and PPU update (wrong PIN2)</i>	+ CME ERROR: 16 <i>Note: Incorrect password</i>
AT+CPUC? <i>Note: Request Currency and Price</i>	+CPUC:"FFR","0.82" OK <i>Note: Currency= "FFR" Price per unit= "0.82"</i>

Call Related Supplementary Services +CHLD

Description:

This command manages call hold and multiparty conversation (conference call). Calls can be put on hold, recovered, released or added to a conversation.

Values

<n>

- 0:** Release all held calls or set User Determined User Busy (UDUB) for a waiting call.
- 1:** Release all active calls (if any exist) and accepts the other (held or waiting) call.
- 1X:** Release a specific call X (active, held or waiting)
- 2:** Place all active calls (if any exist) on hold and accepts the other (held or waiting) call.
- 2X:** Place all active calls on hold except call X with which communication is supported.
- 3:** Adds a held call to the conversation.
- 4:** Connects the two calls and disconnects the subscriber from both calls (Explicit Call Transfer).

Command syntax: AT+CHLD= < n >

Response syntax: +CHLD: (0-4, 11-17, 21-27) for AT+CHLD=?

Command	Possible responses
AT+CHLD=<n>	OK <i>Note: If n is within the defined values</i>
AT+CHLD=?	+CHLD: (0-4, 11-17, 21-27) OK

List Current Calls +CLCC

Description:

This command returns a list of current calls.

Values:

- <idx>** integer type, call identification as described in GSM 02.30
- <dir>**
- 0: mobile originated (MO) call
 - 1: mobile terminated (MT) call
- <stat>** (state of the call):
- 0: active
 - 1: held
 - 2: dialing (MO call)
 - 3: alerting (MO call)
 - 4: incoming (MT call)
 - 5: waiting (MT call)
- <mode>** (teleservice):
- 0: voice
 - 1: data
 - 2: fax
 - 9: unknown
- <mpty>**
- 0: call is not one of multiparty (conference) call parties
 - 1: call is one of multiparty (conference) call parties
- <number>** string type phone number in format specified by <type>
- <type>** type of address byte in integer format
- <alpha>** optional string type alphanumeric representation of <number> corresponding to the entry found in phonebook. (for UCS2 format see commands examples +CLIP, +CCWA or +COLP)

Command syntax: AT+CLCC

Response syntax: OK (if no calls are available)

Else:

```
+CLCC: <id1>, <dir>, <stat>, <mode>, <mpty> [,<number>, <type>
[ <alpha> ] ]
[<CR><LF>
+CLCC: <id2>, <dir>, <stat>, <mode>, <mpty> [,<number>, <type>
[ <alpha> ] ] [ . . . ] ] ]
<CR><LF>
OK
```

Command	Possible responses
RING <i>Note: Incoming call</i>	
AT+CLCC	+CLCC: 1,1,4,0,0,"0146294079",129 OK
ATA <i>Note: Answering the call</i>	OK
AT+CLCC	+CLCC: 1,1,1,0,0,"0146294079",129 OK
ATD0146299704 <i>Note: Outgoing Call</i>	OK
AT+CLCC <i>Note: Before the phone called is ringing</i>	+CLCC: 1,0,2,0,0,"0146294079",129 OK
AT+CLCC <i>Note: The phone called is ringing</i>	+CLCC: 1,0,3,0,0,"0146294079",129 OK
AT+CLCC <i>Note: The call is being answered</i>	+CLCC: 1,0,0,0,0,"0146294079",129 OK

Supplementary Service Notifications +CSSN

Description:

This command refers to supplementary service related network initiated notifications.

Values:

<n> Parameter sets/shows the +CSSI result code presentation status

0: disable

1: enable

<m> Parameter sets/shows the +CSSU result code presentation status

0: disable

1: enable

<code1>

4: closed User Group call, with CUG <index>

5: outgoing calls are barred

6: incoming calls are barred

7: CLIR suppression rejected

<code2>

1: closed User Group call, with CUG <index>

2: call has been put on hold (during a voice call, <number> & <type> fields may be present)

3: call has been retrieved (during a voice call, <number> & <type> fields may be present)

4: multiparty call entered (during a voice call, <number> & <type> fields may be present)

5: call on hold has been released (during a voice call)

7: call is being connected (alerting) with the remote party in alerting state in Explicit Call Transfer operation (during a voice call)

8: call has been connected with the other remote party in Explicit Call Transfer operation (during a voice call, <number> & <type> fields may be present)

<index> Closed User Group index

<number> String type phone number

<type> Type of address

Command syntax: **AT+CSSN= <n>, <m>**

When <n>=1 and a supplementary service notification is received after a mobile originated call setup, intermediate result code **+CSSI:<code1>[,<index>]** is sent before any other MO call setup result codes.

When <m>=1 and a supplementary service notification is received during a call, unsolicited result code **+CSSU:<code2>[,<index>[,<number>,<type>]]** is sent.

Unstructured Supplementary Service Data +CUSD

Description:

The USSD supplementary service is described in GSM 02.90. It is based on sequences of digits which may be entered by a mobile user with a handset. A sequence entered is sent to the network which replies with an alphanumeric string, for display only, or for display plus request for the next sequence.

This command is used to:

- Enable or disable the CUSD indication sent to the application by the product when an incoming USSD is received
- Send and receive USSD strings

Values:

<n>

- 0:** Disable the result code presentation
- 1:** Enable the result code presentation
- 2:** Cancel session (not applicable to read command response)

<m>

- 0:** no further user action required (network initiated USSD-Notify, or no further information needed after mobile initiated operation)
- 1:** further user action required (network initiated USSD-Request, or further information needed after mobile initiated operation)
- 2:** USSD terminated by network
- 4:** Operation not supported

<str> is network string, converted in the selected character set

<dcs> is the data coding scheme received (GSM TS 03.38).

Command syntax: **AT+CUSD = <n> [,<str> [<dcs>]]**

Note: In case of enabled presentation, a +CUSD (as direct answer to a send USSD) is then indicated with:
+CUSD: <m> [,<str>,<dcs>]

Command Syntax To Send and Receive USSD: **AT+CUSD= <n> [,<str> [,<dcs>]]**

Note: Please be aware that the send USSD command needs the user to re-enter the <n> parameter!

Values for “To Send and Receive USSD”

<str> The USSD string to be sent.

<dcs> The default alphabet and the UCS2 alphabet are supported.

When the product sends a USSD, an OK response is first returned, the intermediate +CUSD indication comes subsequently. In case of error, a +CUSD: 4 indication is returned.

Closed User Group +CCUG

Description:

The Closed User Group Supplementary Service enables subscribers to form closed user groups with restricted access (both access to and from).

The CUG supplementary service is described in GSM 02.85. This service is provided on prior arrangement with the service provider. Subscription options should be selected at implementation.

The +CCUG command is used to:

- Activate/deactivate the control of CUG information for all following outgoing calls,
- Select a CUG index.
- Suppress outgoing access (OA). OA allows a member of a CUG to place calls outside the CUG.
- Suppress the preferential CUG. Preferential is the default CUG used by the network when it does not receive an explicit CUG index.

Values:

<n>

- 0: Disable CUG mode (default)
- 1: Enable CUG mode

<index>

- 0-9: CUG index (0 default),
- 10: Preferred CUG

<info>

- 0: No information (default)
- 1: Suppress OA
- 2: Suppress preferential CUG
- 3: Suppress OA and preferential CUG

Note: To activate the control of the CUG information by call, add [G] or [g] to the ATD command. Index and info values will be used.

Command syntax: **AT+CCUG = <n> [,<index> [<info>]]**

CHAPTER 11 - DATA COMMANDS

Using AT Commands During a Data Connection

To use AT Commands during a data connection (such as while the product is in online mode), it is necessary either to switch to offline mode, or to use the **+WMUX** command to enable Commands / Data multiplexing.

Switch from online to offline mode

To switch from online mode to offline mode, the “+++” sequence must be sent. Following this, the product gets back to offline mode with an “OK” response, and an AT command can be sent.

Note: The “+++” sequence only works with the **+ICF** command using the following settings:

- 8 data bits, with no parity
- 7 data bits, with even parity

Switch from offline to online mode

See the **ATO** command description.

Bearer Type Selection +CBST

Description:

This command applies to both outgoing and incoming data calls. For an outgoing call, the two parameters (e.g. <speed> and <ce>) apply, whereas for an incoming call, only the <ce> parameter applies.

Notes:

- For incoming calls, if <ce> is set to T only and the network offers NT only or vice versa, then the call is released.
- The values 2 and 3 for the <ce> parameter are equivalent to the former values of 100 and 101. Those values are managed for compatibility purposes, but they should no longer be used in the new code (2 as former 100 and 3 as former 101).

Values:

<speed>

0 (default):	Autobauding(modem type: none)
1:	300 bps (modem type: V.21)
2:	1200 bps (modem type: V.22)
3:	1200/75 bps (modem type: V.23)
4:	2400 bps (modem type: V.22bis)
5:	2400 bps (modem type: V.26ter)
6:	4800 bps (modem type: V.32)
7:	9600 bps (modem type: V.32)
8:	Specific
12:	9600 bps (modem type: V.34)
14(*):	1400 bps (modem type: V.34)
65:	300 bps (modem type: V.110)
66:	1200 bps (modem type: V.110)
68:	2400 bps (modem type: V.110)
70:	4800 bps (modem type: V.110)
71:	9600 bps (modem type: V.110)
75(*):	14400 bps (modem type: V.110)

(*)This speed configures data and fax 14.4 kbps bearers.

<name> No data compression is provided and only asynchronous modem is supported (<name> = 0).

<ce>: Connection element

0:	Transparent only
1 (default):	Non transparent only
2:	Transparent preferred
3:	Non transparent preferred

Command syntax: AT+CBST= <speed>, <name>, <ce>

Command	Possible responses
AT+CBST=? <i>Note: Test command</i>	+CBST: (0-8,65,66,68,70,71),(0),(0-3) OK <i>Note: Data 14,4 kbps not supported</i>
AT+CBST=? <i>Note: Test command</i>	+CBST: (0-8,12,14,65,66,68,70,71,75),(0),(0-3) OK <i>Note: Data 14,4 kbps not supported</i>
AT+CBST=7,0,1 <i>Note: Ask for a bearer</i>	OK <i>Note: Bearer supported</i>
AT+CBST? <i>Note: Current values</i>	+CBST:7,0,1 OK <i>Note: Command valid</i>
AT+CBST=81,0,0 <i>Note: Ask for a bearer</i>	+CME ERROR: 4 <i>Note: Bearer not supported</i>

Select Mode +FCLASS

Description:

This command puts the product into a particular operating mode (data or fax).

Values:

<n>

- 0: Data
- 1: Fax class 1
- 2: Fax class 2

Command syntax: **AT+FCLASS= <n>**

Command	Possible responses
AT+FCLASS=? <i>Note: Test command</i>	+FCLASS: (0,1) OK <i>Note: Fax class 2 not supported</i>
AT+FCLASS=? <i>Note: Test command</i>	+FCLASS: (0,1,2) OK <i>Note: Fax class 2 supported</i>
AT+FCLASS=0 <i>Note: Data mode requested</i>	OK <i>Note: Command valid</i>
AT+FCLASS=1 <i>Note: Fax class 1 mode requested</i>	OK <i>Note: Command valid</i>
AT+FCLASS? <i>Note: Current value</i>	+FCLASS: 1 OK <i>Note: Command valid</i>

Service Reporting Control +CR

Description:

This command enables a more detailed type of service reporting in the case of incoming or outgoing data calls. Before sending the CONNECT response to the application, the product will specify the type of data connection that has been set up.

These report types are:

- +CR: ASYNC** For asynchronous transparent
- +CR: REL ASYNC** For asynchronous non-transparent

Values:

<mode>

- 0: Disable extended reports
- 1: Enable extended reports

Command syntax: **AT+CR=<mode>**

Command	Possible responses
AT+CR=0 <i>Note: Extended reports disabled</i>	OK <i>Note: Command valid</i>
AT+CR=1 <i>Note: Extended reports enabled</i>	OK <i>Note: Command valid</i>
AT+CR?	+CR: 1 OK
AT+CR=?	+CR: (0,1) OK

Cellular Result Codes +CRC

Description:

This command shows more detailed ring information for an incoming call (voice or data). Instead of the string "RING", an extended string is used to indicate which type of call is ringing (e.g. +CRING: VOICE).

These extended indications are:

+CRING: ASYNC	for asynchronous transparent
+CRING: REL ASYNC	for asynchronous non-transparent
+CRING: VOICE	for normal speech.
+CRING: FAX	for fax calls

Values:

<mode>

- 0: Disable extended reports
- 1: Enable extended reports

Command syntax: AT+CRC=<mode>

Command	Possible responses
AT+CRC=0 <i>Note: Extended reports disabled</i>	OK <i>Note: Command valid</i>
AT+CRC=1 <i>Note: Extended reports enabled</i>	OK <i>Note: Command valid</i>
AT+CRC?	+CRC: 1 OK
AT+CRC=?	+CRC: (0,1) OK

DTE-DCE Local Rate Reporting +ILRR

Description:

This parameter controls whether or not the extended-format "+ILRR:<rate>" information text is transmitted from the DCE to the DTE. The <rate> reported represents the current (negotiated or renegotiated) DTE-DCE rate.

If enabled, the intermediate result code is transmitted in an incoming or outgoing data call, after any data compression report, and before any final result code (CONNECT).

Values:

<value>

- 0: Disable local port rate report
- 1: Enable local port rate report

<rate> Can take the following values: 300, 600, 1200, 2400, 4800, 9600, 19200, 38400, 57600, 115200 Kbps.

Command syntax: AT+ILRR = <value>

Command	Possible responses
AT+ILRR=0 <i>Note: Local port rate report disabled</i>	OK <i>Note: Command valid</i>
AT+ILRR=1 <i>Note: Local port rate report enabled</i>	OK <i>Note: Command valid</i>
AT+ILRR?	+ILRR: 1 OK
AT+ILRR=?	+ILRR: (0,1) OK

Radio Link Protocol Parameters +CRLP

Description:

This command changes the radio link protocol parameters used for non transparent data transmission.

Values:	Range:	Description:
<iws>	0-61:	Down window size, (default is 61)
<mws>	0-61:	Up window size, (default is 61)
<T1>	40-255:	Acknowledgement timer in units of 10ms, (default is 48)
<N2>	1-255:	Retransmission attempts, (default is 6)
<ver>	0-1:	Version number
0:		V42bis is not supported
1:		V42bis is supported

Command syntax: AT+CRLP=<iws>,<mws>,<T1>,<N2>,<ver>

Command	Possible responses
AT+CRLP=? <i>Note: Test command</i>	+CRLP: (0-61),(0-61),(40-255),(1,255),(0) OK <i>Note: V42bis not supported</i>
AT+CRLP=? <i>Note: Test command</i>	+CRLP: (0-61),(0-61),(40-255),(1,255),(0,1) OK <i>Note: V42bis supported</i>
AT+CRLP=61,61,48,6,0 <i>Note: Set new parameters</i>	OK <i>Note: Command valid</i>
AT+CRLP? <i>Note: Current values</i>	AT+CRLP: 61,61,48,6,0 <i>Note: Command valid</i>

Other Radio Link Parameters +DOPT

Description:

This command allows some supplementary radio link protocol parameters to be changed.

Values:

<reset_allowed>

- 0: Data communication is hung up in case of bad radio link.
- 1 (default): Data communication continues in case of bad radio link (**possible loss of data**)

< dtx_allowed >

- 0: Normal mode
- 1 (default): Economic battery mode (not supported by all networks)

Command syntax: AT+DOPT=<reset_allowed>,<dtx_allowed>

Command	Possible responses
AT+DOPT=1 <i>Note: Set new parameters</i>	OK <i>Note: Command valid</i>
AT+DOPT+? <i>Note: Test command</i>	(0,1),(0,1) OK <i>Note: DTX is supported</i>
AT+DOPT=1,1 <i>Note: Set new parameters</i>	OK <i>Note: Command valid</i>
AT+DOPT? <i>Note: Current values</i>	1,1 OK <i>Note: Command valid</i>

Select Data Compression %C

Description:

This command enables or disables data compression negotiation if this feature is supported on the product.

Values:

<n>

0: no compression (default)

2: V42bis compression if supported

Command syntax: **AT%C<n>**

Command	Possible responses
AT%C0 <i>Note: Command</i>	OK <i>Note: Feature supported</i>
AT%C2 <i>Note: Command</i>	OK <i>Note: V42bis supported</i>
AT%C? <i>Note: Current value</i>	2 OK <i>Note: Command valid</i>

V42bis Data Compression +DS

Description:

This command enables or disables V.42bis data compression if this feature is supported on the product. Note that the product allows only the MNP2 protocol.

Values:

<dir>: Specifies the desired direction(s) of operation of the data compression function; from the DTE point of view, (default is 3)

0: Negotiated ... no compression

1: Transmit only

2: Receive only

3: Both directions, accept any direction

<neg>: Specifies whether or not the DCE should continue to operate if the desired result is not obtained, (default is 0)

0: Do not disconnect if V.42 bis is not negotiated by the remote DCE as specified in <dir>

1: Disconnect if V.42 bis is not negotiated by the remote DCE as specified in <dir>

<P1> Specifies the maximum number of dictionary entries that should be negotiated, Range is 512 to 4096. Default is 4096.

<P2> Specifies the maximum string length to be negotiated. Range is 6 to 250. Default is 20.

Command syntax: **AT+DS=<dir>,<neg>,<P1>,<P2>**

Command	Possible responses
AT+DS=? <i>Note: Test command</i>	+DS: (0-3),(0,1),(512-4096),(6-250) OK
AT+DS=3,0,4096,250 <i>Note: Set new parameters</i>	OK <i>Note: Command valid</i>
AT+DS? <i>Note: Current values</i>	+DS: 3,0,4096,20 OK <i>Note: Command valid</i>

V42bis Data Compression Report +DR

Description:

This command determines whether or not the use of V42bis is allowed for an incoming or outgoing data call, if this feature is provided by the product. The intermediate result code represents current DCE-DCE data compression type. The format of this result code is as follows:

+DR: NONE	Data compression is not in use
+DR: V42B	Rec. V.42 bis is in use in both directions
+DR: V42B RD	Rec. V.42 bis is in use in receive direction only
+DR: V42B TD	Rec. V.42 bis is in use in transmit direction only

The +DR intermediate result code, if enabled, is issued before the final result code, before the +ILRR intermediate report and after the service report control +CR.

Values:

<status>	State of the V42bis
0:	Disable. Default value.
1:	Enable

Command syntax: AT+DR

Command	Possible responses
AT+DR=? <i>Note: Test command</i>	+DR: (0-1) OK
AT+DR=1 <i>Note: Reporting enabled</i>	OK <i>Note: Command valid</i>
AT+DR? <i>Note: Current value</i>	+DR: 1 OK <i>Note: Command valid</i>

Select Data Error Correcting Mode \N

Description:

If this feature is provided by the product, this command controls the preferred error correcting mode for a data connection. It can only be used for transparent data transmission.

If the MNP2 feature is provided, the product authorizes MNP error correction mode.

Values:

<n>	
0 (default):	Disables error correction mode
2:	Selects an auto reliable mode (LAPM connection, then MNP connection)
4:	Selects LAPM error correction mode
5:	Selects MNP error correction mode

Note: +E prefixed commands of V.25 ter are not used.

Command syntax: AT\N<n>

Command	Possible responses
AT\N0 <i>Note: no error correction</i>	OK
AT\N? <i>Note: Current value</i>	0 OK <i>Note: Command valid</i>
AT\N4	+CME ERROR: 3

CHAPTER 12 - FAX COMMANDS

The fax service provided by the product is class 1 compatible. However, only the core commands defined by ITU T.31 are supported. This means that commands such as AT+FAR, +FCC, etc. are not supported. Autobauding must be enabled to set up the product for fax.

All set commands below return an ERROR response code if they are not issued during communication.

Transmit speed +FTM

Description:

This command sets the fax transmit speed.

Values:

<speed>

24:	2400 bps (modem type: V.27ter)
48:	4800 bps (modem type: V.27ter)
72:	7200 bps (modem type: V.29)
73:	7200 bps (long) (modem type: V.17)
74:	7200 bps (short) (modem type: V.17)
96:	9600 bps (modem type: V.29)
97:	9600 bps (long) (modem type: V.17)
98:	9600 bps (short) (modem type: V.17)
121:	12000 bps (long) (modem type: V.17)
122:	12000 bps (short) (modem type: V.17)
145:	14400 bps (long) (modem type: V.17)
146:	14400 bps (short) (modem type: V.17)

Command syntax: **AT+FTM=<speed>**

Command	Possible responses
AT+FTM=? <i>Note: Test command</i>	(24,48,72,73,74,96,97,98,121,122,145,146) OK <i>Note: Fax 14.4 kbps supported</i>

Receive Speed +FRM

Description:

This command sets the fax receive speed.

Values:

The speed values are identical to those of the +FTM command.

Command syntax: **AT+FRM=<speed>**

Command	Possible responses
AT+FRM=? <i>Note: Test command</i>	(24,48,72,73,74,96,97,98,121,122,145,146) OK <i>Note: Fax 14.4 kbps supported</i>

HDLC Transmit Speed +FTH

Description:

This command sets the fax transmit speed, using the HDLC protocol.

Values:

<speed>

3 V.21 channels 300 bps.

Command syntax: **AT+FTH=<speed>**

Command	Possible responses
AT+FTH=? <i>Note: Test command</i>	(3) OK

HDLC Receive Speed +FRH

Description:

This command sets the fax receive speed using the HDLC protocol.

Values:

<speed>

3 V.21 channels 300 bps.

Command syntax: **AT+FRH=<speed>**

Command	Possible responses
AT+FRH=? <i>Note: Test command</i>	(3) OK

Stop Transmission and Wait +FTS

Description:

This command stops transmission for the period specified.

Values:

<n>: silence period (units of 10 ms).

Command syntax: **AT+FTS=<n>**

Command	Possible responses
AT+FTS=? <i>Note: Test command</i>	(0-255) OK
AT+FTS=50 <i>Note: Stops transmission and waits for 0.5s</i>	OK <i>Note: Command valid</i>

Receive Silence +FRS

Description:

This command causes the modem to stop listening to the network and report back to the DTE after the specified period. It is aborted if any character is received from the application.

Values:

<n> No listening period in units of 10 ms.

Command syntax: **AT+FRS=<n>**

Command	Possible responses
AT+FRS=? <i>Note: Test command</i>	(0-255) OK
AT+FRS=50 <i>Note: Stops transmission and waits for 0.5s</i>	OK <i>Note: Command valid</i>

Setting Up the PC Fax Application:

The recommended fax application is *Delrina WinFax v8.0*.

It should be configured as follows (menu Setup/Fax Modem Setup):

- Port: any com
- Model: Generic Class 1 (hardware flow control). A generic class 1 with software flow control can also be selected.
- Init: default string is suitable for the product
- Reset: default string is suitable for the product
- Maximum Transmit Rate: 9600 baud (if higher rate will be automatically cut back to 9600 baud).

Other settings are of no relevance for the GSM unit. They can be modified.

CHAPTER 13 - FAX CLASS 2 COMMANDS

If the feature is supported, the commands +FDT, +FDR, +FET, +FPTS and +FK must be used during communication only.

The other commands, +FBOR, +FBUF, +FCQ, +FCR, +FDCC, +FDIS, +FLID and +FPHCTO, cannot be used during communication.

Transmit Data +FDT

Description: This command prefixes data transmission.

Syntax: No parameters

Command syntax: **AT+FDT**

Receive Data +FDR

Description: This command initiates data reception.

Values: No parameters

Command syntax: **AT+FDR**

Transmit Page Punctuation +FET

Description:

This command punctuates page and document transmission after +FDT commands. It indicates that the current page is complete, and whether or not there are additional pages to be sent.

Values:

<ppm>

- 0:** Another page next, same document
- 1:** Another document next
- 2:** No more pages or documents
- 3:** Another partial page next
- 4:** Another page, procedure interrupt
- 5:** Another document, procedure interrupt
- 6:** All done, procedure interrupt

Command syntax: **AT+FET=<ppm>**

The remote station should respond with +FPTS:<ppr>

Page Transfer Status Parameters +FPTS

Description:

This command sets post page transfer response.

Values:

<ppm>

- 1:** Page good
- 2:** Page bad ; retrain requested
- 3:** page good ; retrain requested
- 4:** Page bad ; interrupt requested
- 5:** Page good ; interrupt requested

Command syntax: **AT+FPTS=<ppr>**

Terminate Session +FK

Description: This command causes the product to terminate the session.

Values: No parameters

Command syntax: **AT+FK**

Page Transfer Bit Order +FBOR

Description: This command sets the bit order for negotiation and fax page transfer. The order is related to the bit order or radio link.

Values:

<n>	Bit order for negotiation	Bit order for page transfer
0(default)	Same	Same
1	Same	Reverse
2	Reverse	Same
3	Reverse	Reverse

Command syntax: **AT+FBOR=<n>**

Command	Possible responses
AT+FBOR=? <i>Note: Test command</i>	(0-3) OK

Buffer Size Report +FBUF

Description: This command requests the size of the exchange buffer between the modem and the fax application. **Note:** Only the read command is supported.

Values: No parameters

Command syntax: **AT+FBUF**

Command	Possible responses
AT+FBUF? <i>Note: Current value</i>	1024 OK <i>Note: Command valid</i>

Copy Quality Checking +FCQ

Description: This command controls Copy Quality checking for receiving faxes.

Values:

<n>

0 Default value; the only value supported

Command syntax: **AT+FCQ=<n>**

Command	Possible responses
AT+FCQ=? <i>Note: Test command</i>	(0) OK

Capability to Receive +FCR

Description: This commands controls the capability of the modem to accept incoming faxes.

Values:

<n>

0: The modem will not accept incoming faxes.

1: The modem will accept incoming faxes (default).

Command syntax: **AT+FCR=<n>**

Command	Possible responses
AT+FCR=? <i>Note: Test command</i>	(0,1) OK

Current Sessions Parameters +FDIS

Description: This command allows the DTE to parameter the capabilities used for the current session.

Values: (of the T30 standard):

- <vr>:** Vertical Resolution
0: Normal: 98 lpi. (default)
1: Fine: 196 lpi
-
:** Bit Rate
0: 2400 bps (modem type: V.27 ter)
1: 4800 bps (modem type: V.27 ter)
2: 7200 bps (modem type: V.29)
3: 9600 bps (modem type: V.29, V.17) Default value if 14.4 Kbps IS NOT supported
4: 12000 bps (modem type: V.33, V.17) Only when product supports 14.4 kbps data feature
5: 14400 bps (modem type: V.33, V.17) Only when product supports 14.4 kbps data feature. Default
- <wd>:** Page Width
0: 1728 pixels in 215 mm. (default)
1: 2048 pixels in 255 mm
2: 2432 pixels in 303 mm
- <ln>:** Page Length
0: A4, 297 mm
1: B4, 364 mm
2: Unlimited (default)
- <df>:** Data Compression Format
0: 1-D modified huffman (default)
1: 2-D modified read
2: 2-D uncompressed mode
3: 2-D modified modified read
- <ec>:** Error Correction
0: Disable Fax ECM. Default value if fax ECM feature IS NOT supported.
1: Enable Fax ECM, 64 bytes/frame. Only when product supports fax Error Correction Mode feature.
2: Enable Fax ECM, 256 bytes/frame. Default value if fax EMC feature IS supported. Only when product supports fax Error Correction Mode feature.
- <bf>:** Binary File Transfer,
0 Only 0 is supported.
- <st>:** Scan Time per line,

<st>	Description <vr>=0	Description <vr>=1
0(default)	0 ms	0 ms
1	5 ms	5 ms
2	10 ms	5 ms
3	10 ms	10 ms
4	20 ms	10 ms
5	20 ms	20 ms
6	40 ms	20 ms
7	40 ms	40 ms

Command syntax: **AT+FDIS=<vr>,
,<wd>,<ln>,<df>,<ec>,<bf>,<st>**

Command	Possible responses
AT+FDIS=?	(0,1),(0-5),(0-2),(0-2),(0-3),(0),(0),(0-7) OK <i>Note: Fax ECM not supported</i> <i>Fax 14.4 kbps supported</i>
	(0,1),(0-3),(0-2),(0-2),(0-3),(0),(0),(0-7) OK <i>Note: Fax ECM not supported</i> <i>Fax 14.4 kbps not supported</i>

DCE Capabilities Parameters +FDCC

Description:

This command allows the DTE to parameter the capabilities used for any session.

Values:

The parameters and default values are the same as for the +FDIS command. See previous page.

Command syntax: **AT+FDCC=<vr>,
,<wd>,<ln>,<df>,<ec>,<bf>,<st>**

Command	Possible responses
AT+ FDCC=? <i>Note: Test command</i>	(0,1),(0-5),(0-2),(0-2),(0-3),(0-2),(0),(0-7) OK <i>Note: Fax ECM supported</i> <i>Fax 14.4 kbps supported</i>
	(0,1),(0-5),(0-2),(0-2),(0-3),(0),(0),(0-7) OK <i>Note: Fax ECM not supported</i> <i>Fax 14.4 kbps supported</i>
	(0,1),(0-3),(0-2),(0-2),(0-3),(0-2),(0),(0-7) OK <i>Note: Fax ECM supported</i> <i>Fax 14.4 kbps not supported</i>
	(0,1),(0-3),(0-2),(0-2),(0-3),(0),(0),(0-7) OK <i>Note: Fax ECM not supported</i> <i>Fax 14.4 kbps not supported</i>

Local ID String +FLID

Description:

This command defines the local ID string to be defined.

Values:

<string> The string has a limited size of 20 characters and accepts any characters between 32 and 127 as ASCII codes.

Command syntax: **AT+FLID="<string>"**

Command	Possible responses
AT+FLID=? <i>Note: Test command</i>	(20),(32-127) OK

Page Transfer Timeout Parameter +FPHCTO

Description:

This command sets the period the modem waits for another page before it assumes there are no more pages and aborts.

Values:

<n> Waiting period for another page in seconds. Range 0 to 255. Default 30.

Command syntax: **AT+FPHCTO=<n> (default is 30)**

Command	Possible responses
AT+FPHCTO=? <i>Note: Test command</i>	(0-255) OK

Fax Class 2 Indication Messages

The following messages are used to indicate DCE Responses. They are used in communication only.

+FCON:

This response indicates connection with a fax machine.

**+FDCS <vr>,
,<wd>,<ln>,<df>,<ec>,<bf>,<st>:**

This response reports current session capabilities. The parameters are the same than those of AT+FDIS command (see 0).

**+FDIS <vr>,
,<wd>,<ln>,<df>,<ec>,<bf>,<st>:**

This response reports remote capabilities. The parameters are the same than those of AT+FDIS command (see 0).

+FCFR:

This response indicates confirmation to receive.

+FTSI “<string>”:

This response reports the received transmit station ID string.

+FCSI “<string>”:

This response reports the received called station ID string.

+FPTS <ppr>:

This response reports received page transfer status. The parameter is the same than the one of AT+FPTS command (see 0).

+FET <ppm>:

This response reports post page message response. The parameter is the same than the one of AT+FET command (see 0).

+FHNG <cause>:

This response reports the hang-up cause. It indicates that the call has been terminated.

<cause>

0: Normal end of connection.

10: Unspecified transmit phase A error.

20: Unspecified transmit phase B error.

40: Unspecified transmit phase C error.

50: Unspecified transmit phase D error.

70: Unspecified receive phase B error.

90: Unspecified receive phase C error.

100: Unspecified receive phase D error.

CHAPTER 14 – V.24 AND V.25 COMMANDS

Fixed DTE Rate +IPR

Description:

This command specifies the data rate at which the DCE will accept commands.

Notes:

- Autobauding is supported (operating from 2400 to 115200 baud).
- Any AT command issued by the DTE must start with both capital 'A' and 'T' (or '/') or both lower case 'a' and 't' (or '/'); otherwise, the DCE may return some garbage characters and become desynchronized. Should this happen, the DTE simply issues 'AT\r' (at 2400 or 4800 bauds) once or twice or just 'AT' (at 9600 bauds) to resynchronize the modem.
- The DTE waits for 1ms after receiving the last character of the AT response (which is always '\n' or 0x0A) to send a new AT command at either the same rate or a new rate. Should this delay be ignored, the DCE can become desynchronized. Once again, sending 'AT\r' once or twice or just 'AT' causes the DCE to recover.

Caution: When starting up, if autobauding is enabled and no AT command has yet been received, the product sends all unsolicited responses (like RING) at 9600 bauds.

Values:

<value> Baud rates that can be used by the DCE

0 Enables autobauding

300

600

1200

2400

4800

9600

19200

38400

57600

115200

Command syntax: AT+IPR=<value>

Command	Possible responses
AT+IPR?	+IPR: 9600 OK <i>Note: Current rate is 9600 bps</i>
AT+IPR=?	+IPR: (0,2400,4800,9600,19200,38400,57600,115200), (300,600,1200) OK <i>Note: Possible values, according to V25ter Recommendation: The first set of values indicates the range of auto-detectable baud rates (including 0). The second set of values indicates the baud rates supported by the DCE but not auto-detectable.</i>
AT+IPR=38400	OK <i>Note: Disable autobauding and set rate to 38400 bps</i>
AT+IPR=0	OK <i>Note: Enable autobauding</i>

DTE-DCE Character Framing +ICF

Description:

This command determines the local serial port start-stop (asynchronous) character framing that the DCE uses.

Values:

<format>

- 0: Autodetect (not supported)
- 1: 8 Data 2 Stop (supported)
<parity> parameter is ignored
- 2: 8 Data 1 Parity 1 Stop (supported)
If no <parity> provided, 3 is used by default as <parity> value
- 3: 8 Data 1 Stop (supported)
<parity> parameter is ignored
- 4: 7 Data 2 Stop (supported)
<parity> parameter is ignored
- 5: 7 Data 1 Parity 1 Stop (supported)
If no <parity> provided, 3 is used by default as <parity> value
- 6: 7 Data 1 Stop (supported)
<parity> parameter is ignored

<parity>

- 0: Odd (supported)
- 1: Even (supported)
- 2: Mark (supported)
- 3: Space (supported)
- 4: None (supported)

Notes:

- Setting a character framing different from 8N1 will disable autobauding if it was activated. Setting it back to 8N1 **will not** re-enable autobaud.
- Setting the framing to 8N1 will let autobauding be enabled, if it was already enabled (implying framing was already 8N1).

Command syntax: **AT+ICF= <format>[, <parity>]**

Command	Possible responses
AT+ICF?	+ICF: 3,4 OK <i>Note: Current values</i>
AT+ICF=?	+ICF: (1-6),(0-4) OK <i>Note: Possible values</i>
AT+ICF=2,0	OK <i>Note: New values</i>

DTE-DCE Local Flow Control +IFC

Description:

This command is controls the operation of local flow control between the DTE and DCE.

Values:

< DCE_by_DTE >

- 0: none (supported)
- 1: Xon/Xoff local circuit 103 (not supported)
- 2: RTS (supported)
- 3: Xon/Xoff global on circuit 103 (not supported)

Note:

When this parameter is set to 2 (DTE invokes flow control through RTS) DCE behaviour is as follows: If the DCE has never detected RTS in the high (or ON) condition since startup then it ignores RTS as it assumes that this signal is not connected. As soon as the DCE detects RTS high the signal acts on it. Therefore subsequent RTS transition to OFF will prevent the DCE from sending any further data in both online and offline modes. This behaviour allows the user to use the default settings (hardware flow control) and leave RTS disconnected. In the case where RTS is connected and is high at least once, it acts on the DCE.

< DTE_by_DCE >

- 0: none (supported)
- 1: Xon/Xoff circuit 104 (not supported)
- 2: CTS (supported)

Note: When this parameter is set to 0 (none) then CTS is kept high all the time.

Command syntax: AT+IFC=<DCE_by_DTE>,<DTE_by_DCE>

Command	Possible responses
AT+IFC?	+IFC: 2,2 OK <i>Note: Current values</i>
AT+IFC=?	+IFC: (0,2),(0,2) OK <i>Note: Possible values</i>
AT+IFC=0,0	OK <i>Note: New values</i>

Set DCD Signal &C

Description:

This commands controls the Data Carrier Detect (DCD) signal.

Values:

<n>

- 0 DCD always on
- 1 DCD matches the state of the remote modem's data carrier

Command syntax: AT&C <n>

Command	Possible responses
AT&C0 <i>Note: DCD always on</i>	OK <i>Note: Command valid</i>
AT&C1 <i>Note: DCD matches state of the remote modem's data carrier</i>	OK <i>Note: Command valid</i>

Set DTR Signal &D

Description:

This command controls the Data Terminal Ready (DTR) signal.

Values:

<n>

- 0 The DTR signal is ignored
- 1 Modem switches from data to command mode when DTR switches from ON to OFF
- 2 Upon DTR switch from ON to OFF, the call is released

Command syntax: AT&D <n>

Command	Possible responses
AT&D0 <i>Note: The DTR signal is ignored</i>	OK <i>Note: Command valid</i>
AT&D1 <i>Note: Modem switches from data to command mode when DTR switches from ON to OFF</i>	OK <i>Note: Command valid</i>
AT&D2 <i>Note: Upon DTR switch from ON to OFF, the call is released</i>	OK <i>Note: Command valid</i>

Set DSR Signal &S

Description:

This command controls the Data Set Ready (DSR) signal.

Values:

<n>

- 0 DSR always on
- 1 DSR off in command mode. DSR on in data mode.

Command syntax: AT&S

Command	Possible responses
AT&S0 <i>Note: DSR always on</i>	OK <i>Note: Command valid</i>
AT&S1 <i>Note: DSR off in command mode, DSR on in data mode</i>	OK <i>Note: Command valid</i>

Back to Online Mode O

Description:

If a connection has been established and the ME is in command mode, this command allows you to return to online data mode.

Values: No parameters

Command syntax: ATO

Command	Possible responses
ATO Return from offline mode to online mode	OK

Result Code Suppression Q

Description:

This command determines whether the mobile equipment sends result codes or not.

Values:

<n>

- 0 DCE transmit result codes
- 1 Result codes are suppressed and not transmitted

Command syntax: ATQ

Command	Possible responses
ATQ0 <i>Note: DCE transmits result codes</i>	OK <i>Note: Command valid</i>
ATQ1 <i>Note: Result codes are suppressed and not transmitted</i>	<i>Note: No response</i>

DCE Response Format V

Description:

This command determines the DCE response format, with or without header characters <CR><LF>. Result codes are provided as numeric or verbose.

Values:

	<n>=0	<n>=1
Information responses	<text><CR><LF>	<CR><LF> <text><CR><LF>
Result codes	<numeric code><CR>	<CR><LF> <verbose code><CR><LF>

Command syntax: ATV

Command	Possible responses
ATV0 <i>Note: DCE transmits limited headers and trailers and numeric result codes</i>	0 <i>Note: Command is valid (0 means OK)</i>
ATV1 <i>Note: DCE transmits full headers and trailers and verbose response text</i>	OK <i>Note: Command valid</i>

Default Configuration Z

Description:

This command restores the configuration profile. Any call is released.

Syntax: No parameters

Command syntax: ATZ

Command	Possible responses
ATZ <i>Note:</i>	Ok <i>Note: Command valid</i>

Save Configuration &W

Description:

This command writes the active configuration to a non-volatile memory (EEPROM). For description of the stored parameters, refer to Appendix A.

Values: No parameters

Command syntax: AT&W

Command	Possible responses
AT&W <i>Note: Writes current configuration to EEPROM</i>	OK <i>Note: Command valid</i>

Auto-Tests &T

Description: This command runs various auto-tests.

Values:

AT&T0 is used to perform auto-tests. The response will be OK if no software problem is detected (EEPROM, RAM and ROM checksums), otherwise a simple ERROR response is sent.

AT&T1 is used to close the audio loop and **AT&T2** is used to open the audio loop. This is used to validate the audio loop (microphone to speaker).

<n>

- 0** Perform software auto-tests
The response will be OK if no software problem is detected (EEPROM, RAM, and ROM checksums); otherwise, a simple ERROR response is sent.
- 1** Perform the audio loop test (close)
This is used to validate the audio loop (microphone to speaker)
- 2** Stop the audio loop test (open)
This is used to validate the audio loop (microphone to speaker)

Command syntax: AT&T

Command	Possible responses
AT&T0 <i>Note: Perform software auto-tests</i>	OK <i>Note: No software problem detected, all checksums are correct</i>
AT&T1 <i>Note: Do the audio loop test (close)</i>	OK <i>Note: Command valid</i>
AT&T2 <i>Note: Stop the audio loop test (open)</i>	OK <i>Note: Command valid</i>

Echo E

Description:

This command is used to determine whether the modem echoes characters received by an external application (DTE).

Values:

<n>

- 0** Characters are not echoed
- 1** Characters are echoed

Command syntax: ATE <n>

Command	Possible responses
ATE0 <i>Note: Characters are not echoed</i>	OK <i>Note: Done</i>
ATE1 <i>Note: Characters are echoed</i>	OK <i>Note: Done</i>

Restore Factory Settings &F

Description:

This command is used to restore the factory settings from EEPROM. It only restores the parameters that can be found in the Parameters Storage table with column AT&F checked. Those parameters are restored in RAM and in E2P, overwriting the profile for AT&W.

Values:

<n>

- 0** Restore factory settings

Command syntax: AT&F <n>

Command	Possible responses
AT&F <i>Note: Ask for restoring the factory settings</i>	OK <i>Note: Done</i>
AT&F0 <i>Note: Ask for restoring the factory settings</i>	OK <i>Note: Done</i>

Display Configuration &V

Description:

This command is used to display the modem configuration.

Values:

<n>

- 0 Displays the modem configuration in RAM. Default value if no parameter provided.
- 1 Displays the modem configuration in EEPROM.
- 2 Displays the modem factory configuration.

Command syntax: AT&V <n>

The parameters displayed are the following:

Q: val 1, V: val 2, S0: val 3, S2: val 4, S3: val 5, S4: val 6, S5: val 7,
 +CR: val 8, +CRC: val 9, +CMEE: val 10, +CBST: val 11,
 +SPEAKER: val 12, +ECHO: val 13, &C: val 14, &D: val 15, %C: val 16,
 +IPR: val 17, +ICF: val 18, +IFC: val 19

Command	Possible responses
AT&V <i>Note: Display active parameters in RAM</i>	Q:0 V:1 S0:000 S2:043 S3:013 S4:010 S5:008 +CR:0 +CRC:0 +CMEE:0 +CBST:0,0,1 +SPEAKER:0 +ECHO:0,0 &C:1 &D:2 %C:0 +IPR:9600 +ICF:3,4 +IFC:2,2 OK <i>Note: Done</i> <i>For Echo the first value corresponds to Echo cancellation 1.</i>

Request Identification Information I

Description:

This command causes the product to transmit one or more lines of specific information text.

Values:

<n>

- 0: Displays manufacturer followed by model identification. Equivalent to +CGMI and +CGMM.
- 3: Displays revision identification. Equivalent to +CGMR.
- 4: Displays modem configuration in RAM. Equivalent to &V0.
- 5: Displays modem configuration in EEPROM. Equivalent to &V1.
- 6: Displays modem data features. Lists the supported data rates, data modes, and fax classes.
- 7: Displays modem voice features.

Other values: OK string will be sent back.

Command syntax: ATI

Command	Possible responses
ATI0 <i>Note: Manufacturer and model identifications</i>	WAVECOM MODEM MULTIBAND G850 1900 OK <i>Note: Multiband GSM 850 and PCS</i>
ATI3 <i>Note: Revision identification</i>	640b09gg.Q2406A 1266500 070403 17:04 OK <i>Note: Software release 6.40b, generated on the 4th of July 2003</i>
ATI6 <i>Note: Modem data features</i>	DATA RATES: AUTOBAUD,300,1200,1200/75,2400,4800,9600,14400 DATA MODES: T/NT,ASYNCHRONOUS FAX CLASS 1,2 OK <i>Note: Done</i>
ATI7 <i>Note: Modem voice features</i>	SPEECH CODINGS: FR,EFR,HR OK <i>Note: Done</i>

Multiplexing Mode +WMUX

Description

This command manages the data / AT commands in multiplexing mode. See Appendix B for the Data / Commands multiplexing protocol description.

Values:

<mode>

- 0:** Multiplexing disabled. When the product is online (data communication in progress), no AT command can be used (default).
- 1:** Multiplexing enabled. Data flows and AT commands are multiplexed while in online mode (data communication in progress).<n>

Command syntax **AT+WMUX=<mode>**

Command	Possible responses
AT+WMUX=?	+WMUX: (0-1) OK
AT+WMUX?	+WMUX: 0 OK <i>Note: Data / Commands multiplexing disabled.</i>
AT+WMUX=1 <i>Note: Enable Data / Commands multiplexing.</i>	OK

CHAPTER 15 - SPECIFIC AT COMMANDS

Cell Environment Description +CCED

Description:

This command retrieves the parameters of the main cell and of up to six neighboring cells.

There are two possible methods for the external application to determine these cell parameters:

- On request by the application
- Automatically by the product every 5 seconds.

Automatic mode is not supported during registration.

Values:

<mode>

- 0: One shot requested
- 1: Automatic shots requested
- 2: Stop automatic shots

<requested dump>

1: Main Cell:

- **If the Cell Identity is available** MCC, MNC, LAC, CI, BSIC, BCCH Freq (absolute), RxLev, RxLev Full, RxLev Sub, RxQual, RxQual Full, RxQual Sub, Idle TS
- **If the Cell Identity is not available** MCC, MNC, LAC, BSIC, BCCH Freq (absolute), RxLev, RxLev Full, RxLev Sub, RxQual, RxQual Full, RxQual Sub, Idle TS

2: Neighbor1 to Neighbor6:

- **If the Cell Identity is available** MCC, MNC, LAC, CI, BSIC, BCCH Freq (absolute), RxLev
- **If the Cell Identity is not available** MCC, MNC, LAC,, BSIC, BCCH Freq (absolute), RxLev

4: Timing Advance

8: Main cell RSSI indications (RxLev) in a range from 0 to 31

Notes:

- The response for the requested dump 1, 2, and 4 will be:
+CCED:<value>, ... , <value n>
OK

Where <value> is the ASCII string of the values (in decimal form except the LAC and CI values which are in hexadecimal form) of the parameters. If a field cannot be measured – or is meaningless – the parameter is not filled in and two consecutive commas are sent.

- The response for the requested dump 8 will be a +CSQ response and not a +CCED. The 7.07 format for +CSQ is respected. The <ber> is not evaluated by this command, so the <ber> value will always be 99.
+CSQ:<rsssi>, 99
OK

When automatic shots are selected, this +CSQ response is sent every time the <rsssi> measured by the product changes. Automatic shots are supported in idle mode and during communication. The activation or deactivation of this flow (8) does not affect the other flows.

- In idle mode, only RxLev measurements (on the main cell and on the neighboring cells) are made.

- Combination of the requested dump is supported (addition of the values 1, 2, 4, and 8):

Value	Requested Dump	Value	Requested Dump
1	+CCED response: Main Cell only	9	+CSQ response; then +CCED response with Main Cell only
2	+CCED response: Neighbors 1 to 6	10	+CSQ response; then +CCED response with Neighbors 1 to 6
3	+CCED response: Main Cell; then Neighbors 1 to 6	11	+CSQ response; then +CCED response with Main Cell; then Neighbors 1 to 6
4	+CCED response: Timing Advance Only	12	+CSQ response; then +CCED response with Timing Advance Only
5	+CCED response: Main Cell; then Timing Advance	13	+CSQ response; then +CCED response with Main Cell; then Timing Advance
6	+CCED response: Neighbors 1 to 6; then Timing Advance	14	+CSQ response; then +CCED response with Neighbors 1 to 6; then Timing Advance
7	+CCED response: Main Cell; then Timing Advance; then Neighbors 1 to 6; with each Timing Advance inserted between cell's results	15	+CSQ response; then +CCED response with Main Cell, then its Timing Advance; then Neighbors 1 to 6; with each Timing Advance inserted between cell's results
8	+CSQ response: Main Cell RSSI indications	No value	Last value used for +CCED request or 15

- If requested dump parameter is not provided, one of the last +CCED commands will be used (or 15 by default) will be used.
- Values of MCC/MNC are set to 0 in the case of “No service”.

Command syntax: **AT+CCED=<mode>[, <requested dump>]**

Command	Possible responses
AT+CCED=0 <i>Note: Last request was AT_CCED=0,3 (main cell and neighbors 1 to 6): you can see MCC,MNC sequences (here 208,20)</i>	+CCED:208,20,0002,0418,37,706,24,,,0,,,0,208,20,0006,989b,37,835,20,208,,20,0002,02a9,37,831,12,208,20,0101,7966,34,818,508,20,0006,9899,39,713,9,208,20,0002,0a72,33,711,12,208,20,0101,03fb,36,824,10,1 OK
AT+CCED=0,1 <i>Note: Only Main Cell request</i>	+CCED:208,20,0002,0418,37,706,25,,,0,,,0 OK
AT+CCED=0,1 <i>Note: Call in progress: RxLev and RxQual are empty, RxLevFull, RxLevSub, RxQualFull, and RxQualSub have data</i>	+CCED:208,10,189C,,19,85,,31,32,,0,0 OK

General Indications +WIND

Description:

This command provides a general mechanism to send unsolicited non-standardized indications to the application. The indicators are:

- Indication of a physical change on the SIM detect pin from the connector (meaning SIM inserted, SIM removed)
- Indication during mobile originated call setup that the calling party is ringing.
- Indication of the availability of the product to receive AT commands after boot.

For each of these indications, a “bit flow” has to be indicated.

Values:

<IndLevel>

- 0:** No unsolicited “+WIND: <IndNb>” will occur. **Default.**
- 1 (bit-0):** Hardware SIM Insert/Remove indications (Rack open/close) or SIM presence after software reset
- 2 (bit-1):** Calling party alert indication
- 4 (bit-2):** Product is ready to process AT commands (except phonebooks, AOC, SMS), but still in emergency mode.
- 8 (bit-3):** The product is ready to process all AT commands at the end of init or after swapping to ADN in case of FDN configuration
- 16 (bit-4):** A new call identifier has been created (after an ATD command, +CCWA indication)
- 32 (bit-5):** An active, held or waiting call has been released by network or other party
- 64 (bit-6):** Network service available indication
- 128 (bit-7):** Network lost indication
- 256 (bit-8):** Audio ON indication
- 512 (bit-9):** SIM Phonebooks reload status
- 1024 (bit-10):** Sim phonebooks checksum indication
- 2048 (bit-11):** Interruption indication (only if FTR_INT is activated)

Combination (addition of the values) is used to allow more than one indication flow.

0 • IndLevel • 4095

The **response** is OK if the values are in the previous range.

<event>

- 0:** The SIM presence pin has been detected as “SIM removed” (depending on 0 bit flow)
- 1:** The SIM presence pin has been detected as “SIM inserted”
- 2:** Calling party is alerting
- 3:** Product is ready to process AT commands (except phonebooks, AOC, SMS), at init or after AT+CFUN=1
- 4:** Product is ready to process all AT commands, end of phonebook init or swap (FDN to ADN)
- 5:** Call <idx> has been created (after ATD or +CCWA...)
- 6:** Call <idx> has been released, after a NO CARRIER, a +CSSU: 5 indication, or after the release of a call waiting
- 7:** The network service is available for an emergency call.
- 8:** The network is lost.
- 9:** Audio ON.
- 10:** Show reload status of each SIM phonebook after init phase (after Power-ON or SIM insertion).
- 11:** Show the checksum of Sim phonebooks after loading them
- 12:** An interruption has occurred

Or for event 10:

<phonebook>: SIM phonebook (“SM”, “FD”, “ON”, “SN”, “EN”)

<status>:

- 0:** Not Reloaded from SIM (no change since last init or SIM remove)
- 1:** Reloaded from SIM to internal memory (at least one entry has changed)

Or for event 11:

<checksum>: 128-bit “fingerprint” of the phonebook.

Note: If the service of the phonebook is not loaded or not present, the checksum is not displayed and two commas without checksum are displayed (,,).

Command syntax: AT+WIND= <IndLevel >

Command	Possible responses
AT+WIND?	+WIND: 0 OK
AT+WIND=255	OK
<i>Note: The SIM has been removed.</i>	+WIND: 0 <i>Note :The SIM presence pin has been detected as “SIM inserted”</i>
<i>Note: The SIM has been removed.</i>	+WIND: 1 <i>Note :The SIM presence pin has been detected as “SIM inserted”</i>
<i>Note: The network service is available for an emergency call</i>	+WIND: 7
<i>Note: The initialization has been completed</i>	+WIND: 4

Additional Notes:

- The AT+WIND? command is supported and indicates the <allowed bit flows>.
- AT+WIND settings are automatically stored in non volatile memory (EEPROM). This means the &W command does not need to be used and the selected flows are always activated after boot.
- Default value is 0: no flow activated, no indication.
- AT+WIND=? gives the possible value range (0-4095)
- The unsolicited response will then be:
+WIND: <event> [,<idx>]
<idx>: Call identifier, defined in +CLCC command.
- Or for event 10:
+WIND: <event>,<phonebook>,<status>,...,<phonebook>,<status>
- Or for event 11:
+WIND: <event>,[“<checksum of SM>”],[“<checksum of FD>”],[“<checksum of ON>”],[“<checksum of SN>”],[“<checksum of EN>”],[“<checksum of LD>”]

Analog Digital Converter Measurements +ADC

Description:

This command gets the (DC level * 1024) of ADC A and ADC B, and possibly ADC C. These voltages are coded on 10 bits.

Values:

<n>

0: Select 2 converters

1: Select 3 converters

<ADCValA>

ADC A value, coded on 10 bits. The value returned includes the resistor bridge. Values are updated every 10 seconds. Displayed on modes 0 and 1.

<ADCValB>

ADC B value, coded on 10 bits. Displayed on modes 0 and 1.

<ADCValC>

ADC C value, coded on 10 bits. Displayed on mode 1 only.

Command syntax: AT+ADC

Command	Possible responses
AT+ADC=? <i>Note: Ask for the list of possible values</i>	+ADC: (0-1) <i>Note: possible values 0 or 1</i>
AT+ADC=0 <i>Note: Select 2 converters (mode 0)</i>	OK <i>Note: 2 converters mode selected</i>
AT+ADC? <i>Note: Ask for the current values of converters in mode 0</i>	+ADC: 500,412 OK <i>Note: ADC A, ADC B on 10 bits</i>
AT+ADC=1 <i>Note: Select 3 converters (mode 1)</i>	OK <i>Note: 3 converters mode selected</i>
AT+ADC? <i>Note: Ask for the current values of converters in mode 1</i>	+ADC: 712,698,997 OK <i>Note: ADC A, ADC B, ADC C on 10 bits</i>

Mobile Equipment Event Reporting +CMER

Description:

This command enables or disables sending of unsolicited result codes in the case of a key press.

Values:

<keyp> (keypad):

- 0: No keypad event reporting.
- 1: Keypad event reportings are routed using unsolicited code: +CKEV: <key>, <press> only those key pressings, which are not caused by +CKPD are indicated.
- 2: Keypad event reportings are routed using unsolicited code: +CKEV: <key>, <press> all key pressings are indicated.

Note: As AT software does not manage the emulation of key press, the values 1 and 2 lead to the same results.

<ind>

- 0: No indicator event reporting
- 1: Indicator event reporting using unsolicited result code. Only the indicator events not caused by +CIND shall be indicated by the TA to the TE.

<key>: Keyboard map is (5,5)

0	1	2	3	4
5	6	7	8	9
10	11	12	13	14
15	16	17	18	19
20	21	22	23	24

<press>

- 1: key press
- 0: key release

<indresp> Indicator order number (as specified for +CIND)

<value> New value of the indicator

Command Syntax: AT+CMER=<mode>,<keyp>,<disp>,<ind>,<bfr>

Response Syntax: +CKEV: <key>, <press> (key press event report)

Response Syntax: +CIEV: <indresp>, <value> (indicator event report)

Command	Possible responses
AT+CMER=1 <i>Note: Ask for key press event report</i>	OK
	+CKEV:12,1 +CKEV:12,0 <i>Note: Key 12 has been pressed and released</i>
AT+ADC? <i>Note: Ask for the current values of converters in mode 0</i>	+ADC: 500,412 OK <i>Note: ADC A, ADC B on 10 bits</i>
AT+CMER?	+CMER: 3,1,0,0,0 OK

Indicator Control +CIND

Description:

This command is used to read or set the values of ME indicators. If ME does not allow setting of indicators or if ME is not currently reachable, an error code is returned.

Values:

<ind> interger type value, which shall be in range of corresponding **<desc>**:

- 0: Indicator is OFF or in a state that can be identified as an "OFF" state.
- 1: Indicator is ON or in a state that is more substantial than the "OFF" state.
- 2: This value is more substantial than 1, and so on.

Note: If the indicator is a simple ON/OFF style element, it has only values 0 and 1.

<desc>

- battchg:** Battery charge level (0-5)
- signal:** Signal quality (0-5)
- service:** Service availability (0-1)
- message:** Message received (0-1)
- call:** Call in progress (0-1)
- roam:** Roaming memory storage status in the MT (0-1)
- smsfull:** SMS memory storage status in the MT (0-1)
 - 0: Memory locations are available.
 - 1: Memory full.

Command syntax: **AT+CIND=[<ind>[,<ind>[,...]]]**

Response syntax: **+CIND: <ind>[,<ind>[,...]]** or

+CIND: (<desc>,(list of supported <ind>s))[(<desc>,(list of supported <ind>s)) [,...]]

Command	Possible responses
AT+CIND=[<ind>[,<ind>[,...]]] <i>Note: Ask for key press event report</i>	+CME ERROR: <err> <i>Note: ME not reachable</i>
AT+CIND? <i>Note: read ME indicators current values</i>	+CIND: <ind>[,<ind>[,...]]
AT+CIND=? <i>Note: read ME indicators possible values</i>	+CIND: (<desc>,(list of supported <ind>s))[(<desc>,(list of supported <ind>s)) [,...]] OK
AT+CIND?	+CIND: 1,2,1,1,0,0,0 <i>Note: battchg:1 – max=5, signal:2 - max=5, service:1 – we are registered on the network, message:1 – an SMS has been received, call:0 – no call in progress, roam:0 – not roaming, smsfull:0 – SIM card is not full of SMS</i>
AT+CIND=? <i>Note: read possible value for ME indicators</i>	+CIND: ("battchg",(0-5)),("signal",(0-5)),("service":(0-1)),("message",(0-1)),("call",(0-1)),("roam",(0-1)),("smsfull",(0-1)) OK

Mobile Equipment Control Mode +CMEC

Description:

This command selects the equipment that operates the ME keypad, writes to the ME display, and sets the ME indicators. If operation mode is not allowed by the ME, +CME ERROR: <err> is returned.

Values:

<keyp> (keypad):

- 0: ME can be operated only through its keypad (execute command of +CKPD cannot be used).
- 1: ME can be operated only from TE (with command +CKPD).
- 2: ME can be operated only from both TE keypad and TE.

<idsp>

- 0: Only ME can write to its display (only command +CDIS can be used to read the indicators).
- 1: Only TE can write to ME display (with command +CDIS).
- 2: ME display can be written by both ME and TE.

<ind>

- 0: Only ME can set the status of its indicators (command +CIND can only be used to read the indicators).
- 1: Only TE can set the status of ME indicators (with command +CIND).
- 2: ME indicators can be set by both ME and TE

Command Syntax: AT+CMEC=[<keyp>,<disp>,<ind>]]

Response Syntax: +CMEC: <keyp>,<disp>,<ind>

Command	Possible responses
AT+CMEC=[<keyp>,<disp>,<ind>]]	+CME ERROR: <err>
AT+CMEC=[<keyp>,<disp>,<ind>]]	OK
AT+CMEC?	+CMEC: 2,0,0 OK
AT+CMEC=?	+CMEC: (2),(0),(0) OK <i>Note: no change allowed</i>

Read Language Preference +WLPR

Description:

Read a Language Preference value of EF-LP. The first indices should have the highest priority.

Values:

<index> Offset in the available languages range (SIM dependent)

<value> Values for language

Language example:

<value>	Language	<value>	Language
0	German	10	Norwegian
1	English	11	Greek
2	Italian	12	Turkish
3	French	13	Hungarian
4	Spanish	14	Polish
5	Dutch	32	Czech
6	Swedish	33	Hebrew
7	Danish	34	Arabic
8	Portuguese	35	Russian
9	Finnish	36	Icelandic

Command syntax: AT+WLPR= <index >

Response syntax: +WLPR: <value>

Command	Possible responses
AT+WLPR? <i>Note: Read command</i>	+WLPR: 4 OK <i>Note: Four language preferences are available in EF-LP</i>
AT+WLPR=1 <i>Note: Read first EF-LP index value</i>	+WLPR: 5 OK <i>Note: Language preference is 5</i>

Write Language Preference +WLPW

Description:

Write a Language Preference value in EF-LP.

Values:

<index> Offset in the available languages range (SIM dependent)

<value> Values for language

Language example:

<value>	Language	<value>	Language
0	German	10	Norwegian
1	English	11	Greek
2	Italian	12	Turkish
3	French	13	Hungarian
4	Spanish	14	Polish
5	Dutch	32	Czech
6	Swedish	33	Hebrew
7	Danish	34	Arabic
8	Portuguese	35	Russian
9	Finnish	36	Icelandic

Command syntax: AT+WLPW=<index>,<value>

Response syntax: OK or +CME ERROR: <err>

Command	Possible responses
AT+WLPW=1,5 <i>Note: Write Lang Pref equal to 5 in EF-LP with index 1</i>	OK <i>Note: EF-LP correctly updated</i>

Read GPIO Value +WIOR

Description

Read the requested GPI or GPIO pin value.

Notes:

- By default (e.g., after a reset), the I/O ports configuration is set by the **+WIOM** command.
- This command is allowed only on a GPIO not allocated by an Open-AT embedded application or for bus operations.

Values:

<index>

Eight I/O ports are available. The <index> value is between 0 and 7.

<value>

0: I/O port number <index> is reset.

1: I/O port number <index> is set.

Command syntax: AT+WIOR=<index>

Response syntax: +WIOR: <value>

Command	Possible responses
AT+WIOR=0 Read I/O (number 0) value	+WIOR: 0 OK GPIO number 0 is reset

Write GPIO Value +WIOV

Description

Set the requested GPO or GPIO pin value.

Notes:

- By default (e.g., after a reset), the I/O ports configuration is set by the **+WIOM** command.
- This command is allowed only on a GPIO not allocated by an Open-AT embedded application or for bus operations.

Values:

<index>

Eight I/O ports are available. The <index> value is between 0 and 7.

<value>

0: I/O port number <index> is reset.

1: I/O port number <index> is set.

Command syntax: **AT+WIOV=<index >,<value>**

Command	Possible responses
AT+WIOV=2,0 Reset I/O (number 2)	OK GPIO value is written

Input/Output Management +WIOM

Description:

This command sets the default GPIOs configuration (input or output) after reset, and each GPIO default value (if set as an output) after reset.

Note: This command is allowed only on a GPIO not allocated by the Open-AT embedded application or for bus operations.

Values:

<GpioDir> Bit table parameter indicating each GPIO direction.

0: Input

1: Output. Default.

Default value: 255 (all GPIOs set as outputs).

<GpioVal> Bit table parameter indicating each output-configured GPIO value (each bit gives the corresponding GPIO default value).

0: Reset. Default.

1: Set

The GPIOs set as inputs by the <GpioDir> parameter are not affected by the value set by the <GpioVal> parameter.

Notes:

- <GpioDir> bit values for GPI and GPO are ignored.
- <GpioVal> bit values for GPI are ignored.

Command Syntax **AT+WIOM=[<GpioDir>],[<GpioVal>]**

Command	Possible responses
AT+WIOM?	+WIOM: 255,0 OK On reset, all GPIOs are set to 0, as an output.
AT+WIOM=?	+WIOM: (0-255),(0-255) OK Range allowed for the parameters.
AT+WIOM=254 Set GPIO 0 as an input, and all others as outputs.	OK
AT+WIOM=,128 Set GPIO 7 default output value to 1.	OK
AT+WIOM?	+WIOM: 254,128 OK

Abort Command +WAC

Description:

This command allows SMS, SS and PLMN selection related commands to be aborted.

Values: No parameters

Command syntax: AT+WAC

Example:

Command Syntax	Return
AT+WAC	
AT+WAC=?	OK
AT+WAC?	OK

Command	Possible responses
AT+COPS=? <i>Note: Available PLMN</i>	
AT+WAC <i>Note: Abort the request of PLMN list</i>	OK

Play Tone +WTONE

Description:

This command allows a tone to be played on the current speaker or on the buzzer. Frequency, gain and duration can be set.

Values:

<mode>

0: Stop playing.

1: Play a tone

<dest>: Sets the destination (mandatory if <mode>=1)

1: Speaker

2: Buzzer

<freq>: Sets tone frequency (in Hz) (mandatory if <mode>=1).

1: Speaker. Range is between 1Hz and 3999Hz.

2: Buzzer. Range is between 1Hz and 50000Hz.

<gain> (0-15): Sets the tone gain. Range is 0 to 15. Default 9.

<gain>	Speaker (db)	Buzzer (db)
0	0	-0.25
1	-0.5	-0.5
2	-1	-1
3	-1.5	-1.5
4	-2	-2
5	-3	-3
6	-6	-6
7	-9	-9
8	-12	-12
9	-15	-15
10	-18	-18
11	-24	-24
12	-30	-30
13	-36	-40
14	-42	-infinite
15	-infinite	-infinite

<duration> (0-50): Sets tone duration (unit of 100 ms). Range is 0 to 50. Default 0. When this parameter is equal to 0, the duration is infinite, and the tone can be stopped by AT+WTONE=0.

Command syntax: AT+WTONE=<mode>[,<dest>,<freq>,<gain>,<duration>]

Response syntax: OK or +CME ERROR: <err>

Command	Possible responses
AT+WTONE=1,1,300,9,50 <i>Note: Play a tone</i>	OK <i>Note: Done</i>
AT+WTONE=0 <i>Note: Stop playing</i>	OK <i>Note: Done</i>
AT+WTONE=? <i>Note: Test command</i>	OK <i>Note: Done</i>
AT+WTONE? <i>Note: Current value</i>	ERROR

Play DTMF Tone +WDTMF

Description:

This command allows a DTMF tone to be played on the current speaker. DTMF, gain, and duration can be set. This command is only used to play a DTMF tone. To send a DTMF over the GSM network, use the +VTS command.

Values:

<mode>

- 0: Stop playing.
- 1: Play a DTMF tone

<dtmf>: Sets the DTMF to play in (mandatory if <mode>=1).
Value must be in {0-9,*,#,A,B,C,D}

<gain> (0-15): Sets tone gain. The values are identical to those of the +WTONE (speaker) command. Range is 0 to 15 (see array on previous page). By default, the value is 9.

<duration> (0-50): Sets the tone duration (unit of 100 ms).
Range 0 to 50. Default 0 (1-> 0,1 s., 50 -> 5 s.)
When this parameter is 0 (default value), the duration is infinite, and the DTMF tone can be stopped by AT+WDTMF=0.

Command syntax: AT+WDTMF=<mode>[,<dtmf>,<gain>,<duration>]

Response syntax: OK or +CME ERROR: <err>

Command	Possible responses
AT+WDTMF=1,"*",9,100 <i>Note: Play a DTMF tone</i>	OK <i>Note: Done</i>
AT+WDTMF=0 <i>Note: Stop playing</i>	OK <i>Note: Done</i>
AT+WDTMF=? <i>Note: Test command</i>	+WDTMF: (0-1),(0-9,*,#,A,B,C,D),(0-15),(0-50) OK <i>Note: Done</i>
AT+WDTMF? <i>Note: Current value</i>	ERROR

Downloading +WDWL

Description:

This command switches the product to download mode.
Downloading is performed using the 1K-XMODEM protocol.

Values: No parameters

Command syntax: AT+WDWL

Command	Possible responses
AT+WDWL <i>Note: Switch on downloading mode</i>	+WDWL: 0 <i>Note: Start the downloading</i>
	... <i>Note: Downloading in progress</i>
AT+CFUN=1 <i>Note: Reset the product at the end</i>	
	OK <i>Note: Reset completed. New software running</i>

Voice Rate +WVR

Description:

This command allows the voice rate for bearer voice to be configured (available for outgoing calls only).

Values:

<n>: Voice coding type.

- 0: FR
- 1: FR and EFR
- 2: FR, HR with HR preferred
- 3: HR, FR with FR preferred
- 4: EFR,HR with HR preferred
- 5: HR,EFR with EFR preferred.

Command syntax: AT+WVR=<n>

Command Syntax	Return
AT+WVR=?	+WVR: (0,2,3) <i>Note: Half Rate available.</i>
AT+WVR=?	+WVR: (0,1) <i>Note: If ERF available.</i>
AT+WVR=?	+WVR: (0) <i>Note: If HR and EFR available.</i>
AT+WVR=?	+WVR: (0-5) <i>Note: If HR and EFR available.</i>
AT+WVR?	+WVR: <n>

Command Syntax	Return
AT+WVR=1 <i>Note: Configure voice type FR and EFR</i>	OK <i>Note: Bearer is configured</i>
AT+WVR=6 <i>Syntax error</i>	+CME ERROR: 3 <i>Note: Syntax error</i>
AT+WVR? <i>Note: Ask the current value</i>	+WVR: 1 OK

Data Rate +WDR

Description:

This command allows the data rate for bearer data to be configured (available for outgoing calls only).

Values:

<n>: Data coding type.

- 0: FR
- 1: FR, HR with HR preferred
- 2: HR, FR with FR preferred

Command syntax: AT+WDR=<n>

Command Syntax	Return
AT+WDR=<n>	OK
AT+WDR=?	+WDR: (0-2) <i>Note: If Half Rate available.</i>
AT+WDR=?	+WDR: (0) <i>Note: If Half Rate note available.</i>
AT+WDR?	+WDR: <n>

Command	Possible responses
AT+WDR=1 <i>Note: Configure voice type FR,HR with HR preferred.</i>	OK <i>Note: Bearer is configured</i>
AT+WDR=3 <i>Syntax error</i>	+CME ERROR: 3
AT+WDR? <i>Note: Ask the current value</i>	+WDR: 1 OK

Select Voice Gain +WSVG

Description:

The product has 2 voice gain controllers. This **specific** command selects the microphone gain controller.

Values:

- <n> Controller
- 0: Controller 1 (Default)
- 1: Controller 2

Command syntax: AT+WSVG = <n>

Command	Possible responses
AT+WSVG=<n>	
AT+WSVG=0 <i>Note: Select Controller 1 (Default)</i>	OK <i>Note: Controller 1 selected</i>
AT+WSVG=1 <i>Note: Select Controller 2 (Default)</i>	OK <i>Note: Controller 2 selected</i>
AT+WSVG=? <i>Note: Get the list of possible values</i>	+WSVG: (0-1) <i>Note: possible values 0 or 1</i>
AT+WSVG? <i>Note: Get the current value</i>	+WSVG: 1 <i>Note: Controller 1 is selected</i>

Status Request +WSTR

Description:

This command returns some operation status. It can be used to check the state of the initialization sequence; the different values returned are Not started, Ongoing, Finished.

Values:

- <status>
 - 1: Initialization sequence
 - <value>
 - 0: Not started
 - 1: On going
 - 2: Finished
 - 2: Network status
 - <value>
 - 0: No network
 - 1: Network available

Command syntax: AT+WSTR=<status>

Response syntax: +WSTR: <status>,<value>

Command	Possible responses
AT+WSTR=<status>	+WSTR:<status>,<value>
AT+WSTR=1 <i>Note: Select the status 1 (INIT SEQUENCE)</i>	+WSTR: 1,2 OK <i>Note: Init finished</i>
AT+WSTR=2 <i>Note: Select the status 2 (NETWORK STATUS)</i>	+WSTR: 2,1 OK <i>Note: The network is available</i>
AT+WSTR=? <i>Note: Ask the list of possible values</i>	+WSTR: (1-2) <i>Note: possible values: 1, 2</i>

Scan +WSCAN

Description:

This command displays the received signal strength indication (<rssi>) for a specified frequency (in absolute format). This command is not allowed during communication.

Values:

<absolute frequency> frequency in absolute format <rssi>

- 0: -113 dBm or less
- 1: -111 dBm
- 2...30: -109 to -53 dBm
- 31: -51dBm or greater
- 99: not known or not detectable

Command syntax: AT+WSCAN=<absolute frequency>

Response syntax: +WSCAN: <rssi>

Command	Possible responses
AT+WSCAN=50 <i>Note: Request <rssi> of absolute frequency 50</i>	+WSCAN: 23 OK <i>Note: <rssi> is 23.</i>
AT+WSCAN=1025 <i>Note: Request power of absolute frequency 1025</i>	CME ERROR: 3 <i>Note: 1025 is not a valid absolute frequency</i>

Ring Indicator Mode +WRIM

Description:

This command sets or returns the state of the Ring Indicator Mode.

- In pulse RI mode, an electrical pulse is sent on the Ring Indicator signal just before sending any unsolicited AT response in order not to lose AT responses when client tasks are in sleep state. Still in RI mode, when receiving incoming calls, electrical pulses are sent on the RI signal.
- In up-down RI mode, no pulses are sent before unsolicited AT response, and up-down signals are sent when receiving an incoming call.

Values:

<n>

- 0: Up-down RI mode
- 1: Pulse RI mode

Command syntax: AT+WRIM=<n>

Command	Possible responses
AT+WRIM=<n>	OK
AT+WRIM=0 <i>Note: Select up-down RI mode</i>	OK <i>Note: up-down RI mode selected</i>
AT+WRIM=1 <i>Note: Select pulse RI mode</i>	OK <i>Note: pulse RI mode selected</i>
AT+WRIM=? <i>Note: Ask the list of possible values</i>	+WRIM: (0-1) OK <i>Note: possible values 0 or 1</i>
AT+WRIM? <i>Note: Ask the current value</i>	+WRIM: 1 OK <i>Note: current RI mode is pulse RI.</i>

32kHz Power Down Mode +W32K

Description:

This command allows the 32kHz power down mode to be enabled or disabled.

- When power down mode is entered, the product uses a 32kHz internal clock during inactivity stages.
- When enabled, power down mode is active after 1 to 15 minutes. For additional information on power down mode, see *Specification of Power Down Control via RS232*.

Values:

<mode>

- 0: Disable 32kHz powerdown mode
- 1: Enable 32kHz powerdown mode

Command syntax: AT+W32K=<mode>

Command	Possible responses
AT+W32K=1 <i>Note: Enable 32kHz power down mode</i>	OK <i>Note: 32kHz power down mode is enabled</i>
AT+W32K=0 <i>Note: Disable 32kHz power down mode</i>	OK <i>Note: 32kHz power down mode is disabled</i>

Change Default Melody +WCDM

Description:

This command allows a manufacturer specific melody to be selected. This default melody will be played for any new incoming voice call, either on the buzzer or on the speaker.

Values:

<melody>

- 0: No melody (**default**)
- 1...10: Melody 1 to 10

<player>

- 0: Melody n°<melody> will be played on the buzzer for any new incoming voice call. **Default.**
- 1: Melody n°<melody> will be played on the speaker for any new incoming voice call.

Command syntax: AT+WCDM=<melody>,<player>

Command	Possible responses
AT+WCDM=0 <i>Note: Select no melody</i>	OK
AT+WCDM=5 <i>Note: Select melody n°5</i>	OK
AT+WCDM? <i>Note: Indicate the current melody</i>	+WCDM: 5,0 OK <i>Note: Melody n°5 is currently selected, and the buzzer is selected to play it.</i>
	RING <i>Note: An incoming call occurs, and the melody n°5 is played on the buzzer.</i>
AT+WCDM=,1 <i>Note: Select the speaker to play the melody on.</i>	OK
AT+WCDM?	+WCDM: 5,1 OK <i>Note: Now the speaker is selected to play the melody if an incoming call occurs.</i>

Custom Character Set +WCCS

Description:

This command edits and displays the custom character set tables. The “CUSTOM” mode of +CSCS and the +WPCS commands use this character set. In this mode, when the user enters a string, this string is converted into GSM alphabet using the Custom To GSM table. In a similar way, when the user requests a string display, the string is converted from GSM alphabet using the GSM To Custom table.

In edition mode, the edition session is terminated by <ctrl-Z>, or aborted by <ESC>. Only hexadecimal characters ('0'...'9', 'A'...'F') can be used. The number of characters entered must equal the edition range requested, otherwise the command will terminate with a “+CME ERROR: 3” result.

Values:

<mode>

- 0: Display the table
- 1: Edit the table

<table>

- 0: Custom To GSM conversion table
- 1: GSM To Custom conversion table

<char 1>, <char 2> Character range to display/edit.

- 0...127: for GSM To Custom conversion table
- 0...255: for Custom To GSM conversion table

Note: If only <char 1> is present, only this char is displayed/edited.
See Appendix C for informative examples on phonebooks.

Command syntax: AT+WCCS=<mode>,<table>,<char 1>[,<char 2>]

Command	Possible responses
AT+WCCS=0,0,120,130 <i>Note: Display from character 120 to character 130 of the Custom To GSM conversion table</i>	+WCCS: 11, 78797A2020202020097E05 OK <i>Note: 11 characters displayed</i>
AT+WCCS=1,0,115<CR> 20<ctrl-Z> <i>Note: Edit character 115 of the Custom To GSM conversion table</i>	OK <i>Note: Edition successful</i>
AT+WCCS=1,1,0,4<CR> 40A324A5E8<ctrl-Z> <i>Note: Edit the 5 first characters of the GSM To Custom conversion table</i>	OK <i>Note: Edition successful</i>
AT+WCCS=1,1,200 <i>Note: Edit character 200 of GSM To Custom conversion table</i>	+CME ERROR: 3 <i>Note: Index out of range</i>

Lock +WLCK

Description:

This command allows the ME to be locked on a specific network operator.

Note: Test SIM cards (with MCC=001 & MNC=01) doesn't check these locks.

Values:

<fac>

- "PS": SIM lock facility with a 8 digits password (PCK).
- "PN": Network lock with a 8 digits password (NCK).
- "PU": Network subset lock with a 8 digits password (NSCK).
- "PP": Service provider lock with a 8 digits password (SPCK).
- "PC": Corporate lock with a 8 digits password (CCK).

<CnlType> Type of lock for co-operative network list (CNL)

- 0: Automatic (co-operative network list retrieved from EFCNL SIM file)
Note: EFCNL file must be present in SIM to use automatic mode.
- 1: Manual (co-operative network list is given in the <CnlData> parameter)

<CnlData> Co-operative network list (hexa string type) using same format as in EFCNL SIM file (ETSI GSM 11.11 or 3GPP 04.08).

Note: Only if <CnlType> = 1

Command syntax: AT+WLCK=<fac>,<passwd>,<NetId>[,<GID1>[,<GID2>]] [,<CnlType>[,<CnlData>]]

Response syntax: +WLCK: <status>

Command	Possible responses
AT+WLCK="PN",12345678,20810 <i>Note: Activate network lock on SFR (208,10)</i>	OK <i>Note: Network lock activated</i>
AT+WLCK="PS",12345678,208105923568974 <i>Note: Activate SIM lock</i>	OK <i>Note: SIM lock activated</i>
AT+WLCK="PU",12345678,2081035 <i>Note: Activate Network Subset lock on SFR (208, 10, 35).</i>	OK <i>Note: Network Subset lock activated</i>
AT+WLCK="PU",12345678,20810	+CME ERROR: 3 <i>Note: Need 7 digits of IMSI to perform a service provider lock</i>
AT+WLCK="PP",12345678,20810,"E5" <i>Note: Activate Service Provider lock on SFR (208, 10) and GID1 (0xE5).</i>	OK <i>Note: Service Provider lock activated.</i>
AT+WLCK="PC",12345678,20810,"E5","10" <i>Note: Activate Corporate lock on SFR (208, 10), GID1 (0xE5) and GID2 (0x10).</i>	OK <i>Note: Corporate lock activated.</i>
AT+WLCK="PN",12345678,20810,0 <i>Note: Activate Network lock on SFR (208, 10) using co-operative network list from SIM file EFCNL (must be present in SIM)</i>	OK <i>Note: Network lock activated on SFR and co-operative network list present in SIM</i>
AT+WLCK="PN",12345678,20801,1,"02F802FFFFFF02F801FFFFFF" <i>Note: Activate Network lock on F ORANGE (208, 01) with manual co-operative network list including SFR (208, 10) and Bouygues Telecom (208, 20)</i>	OK <i>Note: Network lock activated on F ORANGE (primary network), SFR and Bouygues Telecom (co-operative networks)</i>

CPHS Command +CPHS

Description:

This command is used to activate, deactivate or interrogate a CPHS feature (e.g., Voice Mail Indicator, Mail Box Number...)

Note: This command may answer +CME ERROR: 3 if the CPHS feature is disabled or if the SIM card does not support this CPHS feature.

Values:

<mode>

- 0: Deactivate a CPHS feature
- 1: Activate a CPHS feature
- 2: Interrogate a CPHS status

Note: The deactivate or activate command has no effect on Alternate Line Service, Network Operator Name, CPHS Information, and Customer Profile Service features.

<fctld>

- 1: Voice Mail Indicator
- 2: Mail Box Number
- 3: Alternate Line Service
- 4: Diverted Call Indicator
- 5: Network Operator Name
- 6: CPHS Information
- 7: Customer Service Profile

Note: The Customer Profile Service and Alternate Line Service features are activated if the field is set in CPHS Information and CSP files. The Network Operator is activated if at least one of the two format names exist (Long or Short format). This is done in initialization.

<precision> used only if <mode>=2 and <fctld> = 5 to 7

if <fctld>=5, this field is <type format> (See +WNON)

if <fctld>=6, this field is <date field> (See +WCPI)

if <fctld>=7, this field is <service> (See +WCSP)

<Status>

- 0: CPHS feature disabled
- 1: CPHS feature enabled

Command syntax: **AT+CPHS=<Mode>,<Fctld>**

Command	Possible responses
AT+CPHS=<Mode>,<Fctld> [,precision]	OK
AT+CPHS=<Mode>,<Fctld> [,precision]	+CME ERROR: 3
AT+CPHS?	+CPHS: <Fctld1>,<Status><CR<LF> +CPHS: <Fctld2>,<Status><CR<LF> ... +CPHS: <Fctldn>,<Status><CR<LF>
AT+CPHS=	OK
	OK

CPHS Command Example

AT+CPHS?	+CPHS: 1,0 +CPHS: 2,0 +CPHS: 3,1 +CPHS: 4,0 +CPHS: 5,1 +CPHS: 6,1 +CPHS: 7,1 OK	<i>Interrogate the status of CPHS functionality Voice mail indicator functionality is deactivated Mail box number functionality is deactivated Alternate Line Serve functionality is activated Divert Call Indicator functionality is deactivated Network Operator functionality is activated CPHS Information functionality is activated Customer Service Profile functionality is activated</i>
AT+CPHS=3,1	+CME ERROR: 3	<i>Syntax error</i>
AT+CPHS=1,1	OK	<i>Activate the voice mail indicator functionality</i>
AT+CPHS?	+CPHS: 1,1 +CPHS: 2,0 +CPHS: 3,1 +CPHS: 4,0 +CPHS: 5,1 +CPHS: 6,1 +CPHS: 7,1 OK	<i>Interrogate the status of CPHS functionality Voice mail indicator functionality is activated Mail box number functionality is deactivated Alternate Line Serve functionality is activated Divert Call Indicator functionality is deactivated Network Operator functionality is activated CPHS Information functionality is activated Customer Service Profile functionality is activated</i>
**** the message box contains 1 message ****	+WVMI: 1,1	<i>A message is waiting on Line 1</i>
**** The message box contains a second message ****	+WVMI: 2,1	<i>A message is waiting on Line 2</i>
AT+CPHS=1,4	OK	<i>Activate Divert Call Indicator functionality</i>
****call forwarding is active on Line 1 ****	+WDCI: 1,1	
AT+CPHS=2,1	+WVMI: 1,1 +WVMI: 2,1 +WVMI: 3,0 +WVMI:4,0 OK	<i>Interrogate the status of voice mail indicator functionality a message is waiting on LINE 1 a message is waiting on LINE 2 no data waiting no fax waiting</i>
AT+CPHS=1,2	OK	<i>Activate the mail box number functionality</i>
AT+WALS=1	+WALS:2 OK	<i>Interrogate the status of activated Line Current line is number 2</i>
AT+CPHS=0,4	OK	<i>Deactivate the Divet Call Indicator functionality</i>
AT+CPHS?	+CPHS: 1,1 +CPHS: 2,1 +CPHS: 3,1 +CPHS: 4,0 +CPHS: 5,1 +CPHS: 6,1 +CPHS: 7,1 OK	<i>Interrogate the status of CPHS functionality Voice mail indicator functionality is activated The mail box number functionality is activated Alternate Line Serve functionality is activated Divert Call Indicator functionality is deactivated Network Operator functionality is activated CPHS Information functionality is activated Customer Service Profile functionality is activated</i>
AT+CPHS=2,2	+WMBN: 1,"19254871234",129,1 +WMBN: 2,,,1 +WMBN: 3,,,1 +WMBN: 4,,,1 OK	<i>Query current mail box numbers in SIM Mail box number for Line 1 Mail box number for Line 2 Mail box number for data Line Mail box number for fax Line Only Line1 can be updated</i>

Unsolicited Result: Voice Mail Indicator +WVMI

Description:

This unsolicited indication gives the status of the LINE 1, LINE 2, Data or Fax mailbox. The +CPHS command can be used to know the status of the voice mail indicator for each line.

Values:

<Lineld>

- 1: Line 1
- 2: Line 2
- 3: Data
- 4: Fax

<Status>

- 0: No message waiting.
- 1: At least one message is waiting

Command Syntax: +WVMI: <Lineld>,<Status>

Response Syntax: +WVMI: <Lineld>,<Status>

Command	Possible responses
AT+CPHS=1,1 <i>Note: Activate Voice Mail Indicator feature</i>	OK
AT+CPHS=2,1 <i>Note: Get the current status of Voice Mail Indicator</i>	+WVMI: 1,1 a message is waiting on Line 1 +WVMI: 2,1 a message is waiting on Line 2 +WVMI: 3,0 no data waiting +WVMI: 4,0 no fax waiting
AT+CPHS=2,1	+CME ERROR: 3 <i>Note: CPHS feature is not allowed</i>
AT+CPHS=1,1 <i>Note: Activation of Voice Mail Indicator feature</i>	OK <i>Note: Voice Mail Indicator feature is activated</i>
	+WVMI: 1,1 a message is waiting on Line 1

Unsolicited Result: Diverted Call Indicator +WDCI

Description:

This unsolicited indication provides the call forwarding flags. The +CPHS command can be used to know the status of the Divert Call Indicator for each line.

Values:

<Lineld>

- 1: Line 1
- 2: Line 2
- 3: Data
- 4: Fax

<flag>, <status>

- 0: Call forwarding is deactivated.
- 1: Call forwarding is activated.

Note: Call forwarding SS is set by the AT+CCFC command.

Command Syntax: +WDCI: <Lineld>,<Status>

Response Syntax: +WDCI: <Lineld>,<flag>

Command	Possible responses
AT+CPHS=1,4 <i>Note: Activate Divert Call Indicator feature</i>	OK
AT+CPHS=2,4 <i>Note: Get the current status of Divert Call Indicator</i>	+WDCI: 1,1 divert call indicator is active on Line 1 +WDCI: 2,1 divert call indicator is active on Line 2 +WDCI: 3,0 divert call indicator is deactivated on data +WDCI: 4,0 divert call indicator is active on fax
AT+CPHS=2,4	+CME ERROR: 3 <i>Note: CPHS feature is not allowed</i>
AT+CPHS=1,4 <i>Note: Activation of Divert Call Indicator feature</i>	OK <i>Note: Divert Call Indicator feature is activated</i>
	+WDCI: 1,1 <i>Note: Call forwarding is active on Line 1</i>

Network Operator Name +WNON

Description:

This indication provides the name of the network operator (as a character string). This command is the response to the AT+CPHS 2,5 [<type format>] command.

Values:

<type format>

- 0: Long format operator name
- 1: Short format operator name. Default.

<operator name> The name of the operator in long or short format

Command Syntax: AT+CHPS=2,5,<type format>

Response Syntax: +WNON: <type format>,<operator name>

Command	Possible responses
AT+CPHS=1,5 <i>Note: Get Operator Name</i>	+WNON: 0,"Orange F" OK
AT+CPHS=2,5,1 <i>Note: Get short format Operator Name</i>	+WNON: 1,"Orange" OK
AT+CPHS=2,5,0	+CME ERROR: 3 <i>Note: CPHS feature is not allowed or format name is not accessible</i>
AT+CPHS=2,5,1	+CME ERROR: 3 <i>Note: CPHS feature is not allowed or format name is not accessible</i>
AT+CPHS=2,5,1 <i>Note: Deactivation of Network Operator Name feature</i>	OK <i>Note: No effect</i>

CPHS Information +WCPI

Description:

This indication provides CPHS information; i.e., which data fields are present in the SIM. This command is the response to the AT+CPHS 2,6 [<data field>] command.

Values:

<data field> value indicating the field of CPHS information

If <precision> field is omitted in the AT+CPHS command, all fields of CPHS Information will be displayed.

<status>

- 0: data field is set
- 1: data field is unset

When all CPHS Information is requested, the status corresponds to a bit field.

Note: The field CSP Service (<data field> = 1) is used to set the CSP feature at initialization.

Command Syntax: AT+CHPS=2,6,<data field>

Response Syntax: +WCPI: <data field>,<status>

Command	Possible responses
AT+CPHS=2,6 <i>Note: Get current status for all CPHS Information fields</i>	+WCPI: 0,"0033000F" OK
AT+CPHS=2,6,13 <i>Note: Get the current status of Call Forward Activated Indicator for Line 1</i>	+WCPI: 13,1 OK <i>Note: Call Forward is active for Line 1</i>
AT+CPHS=2,6,22 <i>Note: Get current status for Line 2 Mailbox Number</i>	+WCPI: 22,0 OK <i>Note: Mailbox Number for Line 2 is not available</i>
AT+CPHS=2,6,17	+CME ERROR: 3 <i>Note: Wrong data field</i>
AT+CPHS=2,6,22 <i>Note: Get current status for Line 2 Mailbox Number</i>	+CME ERROR: 3 <i>Note: CPHS feature is not allowed</i>
AT+CPHS=0,6 <i>Note: Deactivation of CPHS Information feature</i>	OK <i>Note: No effect</i>

Customer Service Profile +WCSP

Description:

This indication tells whether or not a service is accessible to the customer. This command is the response to the AT+CPHS 2,7 [,<service>] command.

Values:

<service> value indicating the CSP field to display (See Appendix B).

<status>

0: service is not customer-accessible

1: service is customer-accessible

Note: The field Alternate Line Service (CPHS Teleservices Group) sets the ALS feature at initialization.

Command Syntax: AT+CHPS=2,7[,<service>]

Response Syntax: +WCSP: <service>,<status>

Command	Possible responses
AT+WCSP=?	ERROR
AT+WCSP?	ERROR
AT+CPHS=2,7	+CME ERROR: 3 <i>Note: Syntax error</i>
AT+CPHS=2,7,9 <i>Note: Get current status of Barring All Outgoing Calls</i>	+WCSP: 9,1 OK <i>Note: Barring or All Outgoing Calls is customer accessible</i>
AT+CPHS=2,7,11 <i>Note: Get current status of Barring All Outgoing International Calls</i>	+WCSP: 11,1 OK <i>Note: Barring or All International Outgoing Calls is customer accessible</i>
AT+CPHS=2,7,2 <i>Note: Get current status of Call Forwarding on User Busy</i>	+CME ERROR: 3 <i>Note: CPHS feature is not allowed</i>
AT+CPHS=0,7 <i>Note: Deactivation of CPHS Information</i>	OK <i>Note: No effect</i>

Customer Storage Mirror +WMIR

Description:

This command makes a mirror copy of the current configuration parameters in the EEPROM. In the case of a memory problem for the storage: if a customer mirror already exists, this one will be restored. Otherwise, the default mirrored parameters are restored.

Values: No parameters

Command syntax: AT+WMIR

Command	Possible responses
AT+WMIR=?	OK
AT+WMIR <i>Note: Build the Customer Mirror</i>	OK

Change Default Player +WCDP

Description:

This command allows the default melody player to be selected.

Values:

<player>

0: Buzzer

1: Speaker

Command syntax: AT+WCDP = <player>

Command	Possible responses
AT+WCDP=?	+WCDP: (0-1) OK
AT+WCDP=0 <i>Note: Select the buzzer</i>	OK
AT+WCDP?	+WCDP: 0 OK

CPHS Mail Box Number +WMBN

Description:

This command sets the different mailbox numbers in SIM. The +CPHS command can be used to know which mailbox numbers can be updated.

Values:

<LineId>

- 1: Line 1
- 2: Line 2
- 3: Data
- 4: Fax

<number> Phone number in ASCII format

<type> TON/NPI (Type of address byte in integer format)

<name> name of mailbox

Notes:

- For the <name> parameter, all strings starting with “80”, “81”, or “82” are considered in UCS2 format. See the *Appendix G - Coding of Alpha Fields in the SIM for UCS2*. If a wrong UCS2 format is entered, the string is considered as an ASCII string.
- The AT command +WPCS affects the format of the Mailbox <name> entry.

<status> When checked with “AT+CPHS=2,2”, it indicates if the number can be updated or not:

- 0: Update is not possible
- 1: Update is possible

Command syntax: AT+WMBN = <LineId>,<number>,<type>

Response syntax: (AT+CPHS=2,2)

+WMBN = <LineId>,<number>,<type>,<status>

Command	Possible responses
AT+WMBN=?	OK
AT+WMBN?	OK
AT+CPHS=2,2 <i>Note: Get the current Mail Box Numbers in SIM</i>	+WMBN: 1,"0123456789",129,"Maison" , 1 +WMBN: 2,"9876543210",129,"Travail" , 1 +WMBN: 3,,,,1 +WMBN: 4,,,,1 OK
AT+WMBN=1,"+33122334455",145 <i>Note: Set mailbox number for line.</i>	OK <i>Note: Mailbox number for Line 1 is set.</i>
AT+WMBN=2 <i>Note: Erase mailbox number & name for line 2</i>	OK
AT+CPHS=2,2 <i>Note: Get current Mail Box Numbers again</i>	+WMBN: 1,"+ 33122334455",145,1 +WMBN: 2,,,,1 +WMBN: 3,,,,1 +WMBN: 4,,,,1 OK

Alternate Line Service +WALS

Description:

This command allows you to set and to get the active line. The CPHS command can be used to know which line is active.

Values:

<CmdType>

- 0: Set active line
- 1: Get active line

<LineId> Used only for <CmdType>

- 1: Line 1
- 2: Line 2

Command syntax: AT+WALS = <CmdType>[,<LineId>]

Response syntax: Response to AT+CPHS=2,3: +WALS = <LineId>

Command	Possible responses
AT+WALS?	+WALS: 1 OK <i>Note: Display current active line</i>
AT+WALS=?	+WALS: (0-1),(1-2) OK
AT+WALS = 0,1 <i>Note: Activate Line 1</i>	+WALS: 1 OK
AT+WALS = 0,2 <i>Note: Activate Line 2</i>	+CME ERROR: 3 <i>Note: When the ALS feature is not allowed</i>
AT+WALS = 1 <i>Note: Get the current Active Line</i>	+WALS: 1 <i>Note: Display the current Active Line</i>
AT+WALS = 1,2	+CME ERROR: 3 <i>Note: Syntax error</i>
AT+CPHS=0,3 <i>Note: Deactivation of ALS feature</i>	OK <i>Note: No effect</i>
AT+CPHS=2,3 <i>Note: Interrogate ALS feature</i>	+WALS: 1 <i>Note: Display the current Active Line</i> +CME ERROR: 3 <i>Note: In the case where the ALS feature is not allowed</i>

Open AT Control Command +WOPEN

Description:

This command start, stop, delete, and get information about the current Open AT embedded application.

Note: This command is available only if the Open AT feature is enabled.

Values:

<Mode>

- 0: Stop the embedded application. If this one was running, the product resets
- 1: Start the embedded application. If this one was stopped, the product resets
- 2: Get the Open AT library versions
- 3: Erase the objects flash of Open-AT embedded application
- 4: Erase the Open AT embedded application

Note: Mode = 3 and 4 are only available only if Open AT embedded application is stopped (AT+WOPEN=0).

<IntVersion> ASCII string giving the internal Open AT library version.

<ExtVersion> ASCII string giving the external Open AT library version.

Note: If no embedded application is loaded, the <ExtVersion> parameter does not appear.

Continued: Open AT Control Command

Command syntax: AT+WOPEN=<Mode>

Response syntax: +WOPEN: <Mode>[,<IntVersion>[<ExtVersion>]]

Command	Possible responses
AT+WOPEN=?	+WOPEN: (0-4) OK
AT+WOPEN?	+WOPEN: 0 OK
AT+WOPEN=2 <i>Note: Get the Open AT library versions</i>	+WOPEN: 2, "AT v2.00", "AT v2.00" OK <i>Note: Open AT v2.00 library version. An embedded application has been downloaded on this product</i>
AT+WOPEN=3	OK <i>Note: The objects flash are erased</i>
AT+WOPEN=1 <i>Note: Start the embedded application</i>	OK +WIND: 3 <i>Note: Product reset in order to start the embedded application</i>
AT+WOPEN = 3	+CME ERROR: 532 <i>Note: the embedded application is activated so the objects flash are not erased</i>
AT+WOPEN = 4	+CME ERROR: 532 <i>Note: The embedded application is activated so it cannot be erased</i>
AT+WOPEN=0 <i>Note: Stop the embedded application</i>	OK +WIND: 3 <i>Note: Product reset in order to stop the embedded application</i>
AT+WOPEN=3	OK <i>Note: The objects flash are erased.</i>
AT+WOPEN = 4	OK <i>Note: The embedded application is erased</i>
AT+WOPEN?	+CME ERROR: 3 <i>Note: The Open AT feature is disabled.</i>

Reset +WRST

Description:

This command allows to reset the modem after the time specified by the second parameter.

Values:

<val1>

0: timer reset is disabled

1: timer reset is enabled

<Delay> specify the time for reset

Range "000:00"- "168:59" (format hhh:mm)

<RemainTime> time before next reset

Range "000:01"- "168:59" (format hhh:mm)

Command syntax: AT+WRST =<Mode>,<Delay>

Response syntax: +WRST: <Mode>,<Delay>,<RemainTime>

Command	Possible responses
AT+WRST=?	OK
AT+WRST=0 <i>Note: Disable timer</i>	OK
AT+WRST=1,"001:03" <i>Note: Enable timer and put delay at 1 hour 3 minutes</i>	OK
AT+WRST?	+WRST: 1,"001:03","001:01" OK <i>Note: Timer activated to reset after 1 hour and 3 minutes. At this point, 1 hour and 1 minute remain before next reset.</i>

Set Standard Tone +WSST

Description:

This command sets and gets the sound level of the Standard Tones.

Values:

<sound level>

0: Max volume (default)

15: Min volume

Range [0 ; 15]

<ring tone level>

0: Max volume (default)

15: Min volume

Range [0 ; 15]

Command syntax: AT+WSST=[<sound level>][,<ring tone level>]

Command	Possible responses
AT+WSST=0 <i>Note: Set volume to Max.</i>	OK
AT+WSST=15 <i>Note: Set volume to Min.</i>	OK
AT+WSST=,5 <i>Note: Set ring tone level to 5</i>	OK
AT+WSST? <i>Note: get current standard tones sound level</i>	+WSST: 15,5 OK <i>Note: current standard tones level is 15 (min.), and ring tone level is 5.</i>
AT+WSST=? <i>Note: supported parameters</i>	+WSST: (0-15),(0-15) OK

Hang-up +WATH

Description:

This command disconnects the remote user, specifying a release cause and the location. In the case of multiple calls, all calls are released (active, on-hold and waiting calls).

Values:

<RelCause>:

decimal value from 1 to 127

See table “Failure Cause from GSM 04.08 recommendation.”

<location>:

optional parameter (default value =0)

values as defined in 04.08

- 0 : user
- 1 : private network serving the local user
- 2 : public network serving the local user
- 3 : transit network
- 4 : public network serving the remote user
- 5 : private network serving the remote user
- 7 : international network
- 10: network beyond interworking point

Note: “AT+WATH=0” is the same as “ath.”

Command Syntax: **AT+WATH=<RelCause>,<location>**

Command	Possible responses
AT+WATH=31 <i>Note: Ask for disconnection with release cause=normal and location=USER</i>	OK <i>Note: Every call, if any, are released</i>
AT+WATH=?	+WATH: (1-127),(0-5,7,10)
AT+WATH=17,2 <i>Note: Ask for disconnection with release cause=user busy and location= public network serving the local user</i>	OK <i>Note: Every call, if any, are released</i>

CHAPTER 16 - SIM TOOLKIT

Overview of SIM Application ToolKit

Summary

SIM ToolKit, also known as “SIM Application ToolKit,” introduces new functionalities which open the way to a broad range of value added services. The principle is to allow service providers to develop new applications (*e.g.. for banking, travel, ticket booking, etc.*) for subscribers and to download them into the SIM.

This solution allows new services to be accessible to the user by adding new SIM-based applications without modifying the handset.

Functionality

The term *SIM ToolKit* refers to the functionalities described in the GSM Technical Specification 11.14. It introduces about twenty-five new commands for the SIM. Three classes of ToolKit functionalities have been defined, with Class 1 offering a subset of commands and Class 3 offering the full range of commands (See *the Support of SIM ToolKit Classes table in APPENDIX D*).

The SIM Application ToolKit supports:

- profile download
- proactive SIM
- data download into SIM
- menu selection
- call control by SIM

Profile Download

The Profile Download instruction is sent by the customer application to the SIM as part of the initialization. It is used to indicate which SIM Application ToolKit features the customer application supports. The AT command used for this operation is **+STSF** (*SIM ToolKit Set Facilities*).

Proactive SIM

A proactive SIM provides a mechanism whereby the SIM can ask the customer application to perform certain actions.

These actions include:

- display menu
- display given text
- get user input
- send a short message
- play the requested tone
- set up a call
- provide location information

This mechanism allows SIM applications to generate powerful menu-driven sequences on the customer application and to use services available in the network.

The commands used for this operation are:

- +STIN** (*SIM ToolKit Indication*),
- +STGI** (*SIM ToolKit Get Information*),
- +STGR** (*SIM ToolKit Give Response*).

Data Download to SIM

Data downloading to the SIM allows (*SMS, phonebook...*) data or programs (*Java applets*) received by SMS or by Cell Broadcast to be transferred directly to the SIM Application.

This feature does not need any AT command. It is transparent to the customer application.

Menu Selection

A set of menu items is supplied by the SIM Application ToolKit. The menu selection command can then be used to inform the SIM Application which menu item is selected.

The commands used for this operation are **+STIN**, **+STGI** and **+STGR**.

Call Control by SIM

The call control mechanism allows the SIM to check all dialed numbers, supplementary service control strings and USSD strings before connecting to the network. This gives the SIM the ability to allow, bar or modify the string before the operation starts.

The commands used for this operation are:

+STCR (*SIM ToolKit Control Response*)

+STGR (*SIM ToolKit Give Response*)

Messages Exchanged During a SIM ToolKit Operation

The following scheme shows the SIM ToolKit commands and unsolicited results that are exchanged.

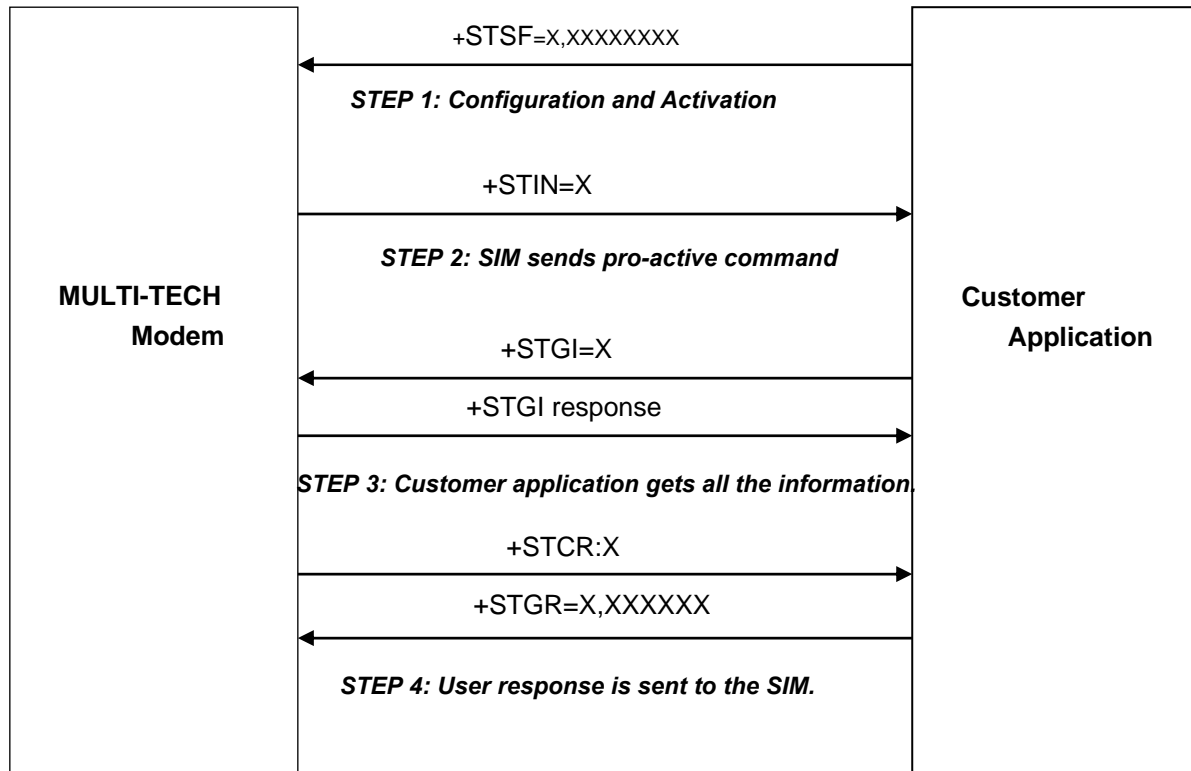

Step 1:

The customer application informs the modem which facilities are supported. This operation is performed with the **+STSF** (*SIM ToolKit Set Facilities*) command, which also activates or deactivates the SIM ToolKit functionality.

Step 2:

An unsolicited result **+STIN** (*SIM ToolKit indication*) is sent by the product in order to indicate to the customer application which command type the SIM Application ToolKit is running. The last SIM ToolKit indication can be requested by the **+STIN?** command.

Step 3:

The customer application uses the **+STGI** (*SIM ToolKit Get Information*) command to get all the information about the SIM ToolKit command, given by **+STIN**.

Step 4:

The customer application uses the **+STGR** (*SIM ToolKit Give Response*) to send its response (*if any*) to the SIM ToolKit Application. The **+STCR** (*SIM ToolKit Control response*) indication is an unsolicited result sent by the SIM when Call control functionality is activated and before the customer application has performed any outgoing call, SMS, SS, or USSD.

SIM Toolkit Commands Section

SIM ToolKit Set Facilities +STSF

Description

This command allows SIM ToolKit facilities to be activated, deactivated or configured.

Values:

<mode>

- 0: Deactivates the SIM ToolKit functionalities.
- 1: Activates the SIM ToolKit functionalities.
- 2: Configures the SIM ToolKit functionalities.

<Config>

(160060C01F – 5FFFFFFF7F) (hex format)

<Timeout>

1-255: Timeout for user responses (multiple of 10 seconds).

<Autoresponse>

- 0: Automatic response is not activated
- 1: Automatic response is activated

Notes about Autoresponse:

- The activation or deactivation of the SIM ToolKit functionalities requires the use of the +CFUN (*Set phone functionality*) command to reset the product (this operation is not necessary if PIN is not entered yet).
- The <Config> parameter gives the coding of the TERMINAL PROFILE, precisely the list of SIM Application ToolKit facilities that are supported by the customer application.
- The <Timeout> parameter (multiple of 10 seconds) sets the maximum time the user has for reacting (to select an item, to input a text, etc).
- When the <Autoresponse> is activated, the +STIN indication for Play Tone (5), Refresh (7), Send SS (8), Send SMS (9) or Send USSD (10) is automatically followed by the corresponding +STGI response.

Note about Bits:

Some bits are related to the product only and not to the customer application. The product automatically sets these bits to either 0 or 1 whatever the user enters with the +STSF command. Those values are given in Appendix D.

Each facility is coded on 1 bit:

- bit = 1: facility is supported by the customer application.
- bit = 0: facility is not supported by the customer application.

Only the first five bytes of the TERMINAL PROFILE (Class 2) can be configured. The other are set to 0. (See structure of TERMINAL PROFILE in APPENDIX E.)

Command syntax: +STSF=<mode>[,<config>][,<Timeout>][,<AutoResponse>]

Command	Possible responses
AT+STSF=<Mode>[,<Config>] [,<Timeout>][,<AutoResponse>]	OK +CME ERROR: <err>
AT+STSF?	+STSF: <Mode>,<Config>,<Timeout>,<Autoresponse>
AT+STSF=?	+STSF: (0-2),(160060C01F - 5FFFFFFF7F),(1-255),(0-1) OK

SIM ToolKit Facilities Error Codes

+CME ERROR: 3 Operation not allowed. This error is returned when a wrong parameter is entered.

Example

AT+CMEE=1		<i>Enable the reporting of mobile equipment errors</i>
	OK	
AT+WIND=15		<i>Set indications</i>
	OK	
AT+CPAS		<i>Query ME Status</i>
	+CPAS: 0	<i>ME is ready.</i>
	OK	
AT+STSF=?		<i>Test command SIM ToolKit Set Facilities</i>
	+STSF: (0-2), (160060C01F – 5FFFFFFF7F),(1-255)	
	OK	
AT+STSF?		<i>No activation of SIM ToolKit functionality</i>
	+STSF: 0,"160060C000",3	
	OK	
AT+STSF=2,"5FFFFFFF7F"		<i>Set all SIM ToolKit facilities (class 3).</i>
	OK	
AT+STSF=3		<i>Syntax Error</i>
	+CME ERROR: 3	
AT+STSF=1		<i>Activation of SIM ToolKit functionality</i>
	OK	
AT+CFUN=1		<i>Reboot Software.</i>
	OK	
AT+CPIN?		<i>Is the ME requiring a password?</i>
	+CPIN: SIM PIN	<i>Yes, SIM PIN required</i>
AT+CPIN=0000		
	OK	<i>PIN OK</i>
	+WIND: 4	<i>Init phase is complete</i>
AT+STSF?		<i>SIM ToolKit functionality activated with all facilities</i>
	+STSF: 1,"5FFFFFFF7F",3	
	OK	

SIM ToolKit Indication +STIN

Unsolicited Result

In order to allow the customer application to identify the pro-active command sent via SIM ToolKit, a mechanism of unsolicited SIM ToolKit indications (**+STIN**) is implemented.

Syntax: AT+STIN: <CmdType>

Option: <CmdType>

- 0:** Indicates that a 'Setup Menu' pro-active command has been sent from the SIM.
- 1:** Indicates that a 'Display Text' pro-active command has been sent from the SIM.
- 2:** Indicates that a 'Get Inkey' pro-active command has been sent from the SIM.
- 3:** Indicates that a 'Get Input' pro-active command has been sent from the SIM.
- 4:** Indicates that a 'Setup Call' pro-active command has been sent from the SIM.
- 5:** Indicates that a 'Play Tone' pro-active command has been sent from the SIM. (*)
- 6:** Indicates that a 'Sel Item' pro-active command has been sent from the SIM.
- 7:** Indicates that a 'Refresh' pro-active command has been sent from the SIM. (*)
- 8:** Indicates that a 'Send SS' pro-active command has been sent from the SIM. (*)
- 9:** Indicates that a 'Send SMS' pro-active command has been sent from the SIM. (*)
- 10:** Indicates that a 'Send USSD' pro-active command has been sent from the SIM. (*)
- 11:** Indicates that a 'SETUP EVENT LIST' pro-active command has been sent from the SIM.
- 98:** Indicates the timeout when no response from user.
- 99:** Indicates that a "End Session" has been sent from the SIM.

(*) if the automatic response parameter is activated, this indication is followed by the corresponding +STGI response.

Last SIM ToolKit Indication

The last SIM ToolKit indication sent by the SIM can be requested by the **AT+STIN?** command. This command is only usable between the sending of the STIN indication by the SIM (Step 2, *Messages exchanged during a SIM ToolKit operation*) and the response of the user with the +STGI command (Step 3).

Command syntax: **AT+STIN?**

Command	Possible responses
AT+STIN? <i>Note: Ask for the last SIM ToolKit indication sent by the SIM</i>	+STIN: 0 OK <i>Note: the last SIM ToolKit indication was a Setup Menu</i>
AT+STGI=0	<i>Note: Display the SIM ToolKit application menu</i>
AT+STIN? <i>Note: Ask for the last SIM ToolKit indication sent by the SIM</i>	+CME ERROR: 4 <i>Note: Operation not supported. The +STGI command has been already used</i>

SIM ToolKit Get Information +STGI

Description

This command allows to get the information (*text to display, menu information, priorities*) of a pro-active command sent from the SIM. The information is returned only after receiving a SIM ToolKit indication (+STIN).

Values: Values are listed after the Command Table

Command syntax: +STGI=<CmdType>

Command	Possible responses
AT+STGI=<CmdType>	See Table 1 +CME ERROR: <err>
AT+STGI=?	+STGI: (0-11) OK

Table of Command Types

Cmd Type	Description	Possible responses
0	Get information about Setup Menu pro-active command.	+STGI: <Alpha Identifier menu> +STGI: <Id1>,<NbItems>,<Alpha Id1 Label>,<Help Info>[,<NextActionId>]<CR><LF> +STGI: <Id2>,<NbItems>,<Alpha Id2 Label>,<Help Info>[,<NextActionId>]<CR><LF> [...] No action expected from SIM.
1	Get information about Display text pro-active command.	+STGI: <Prior>,<Text>,<ClearMode> No action expected from SIM.
2	Get information about Get Inkey pro-active command.	+STGI: <Format>,<HelpInfo>[,<TextInfo>] SIM expects key pressed (+STGR).
3	Get information about Get Input pro-active command.	+STGI: <Format>,<EchoMode>,<SizeMin>,<SizeMax>,<HelpInfo>[,<TextInfo>] SIM expects key input (+STGR).
4	Get information about Setup call pro-active command.	+STGI: <Type>,<CalledNb>,<SubAddress>,<Class> SIM expects user authorization (+STGR).
5	Get information about Play Tone pro-active command.	+STGI: <ToneType>[,<TimeUnit>,<TimeInterval>,<TextInfo>] No action.
6	Get information about Sel Item pro-active command.	+STGI: <DefaultItem>,<Alpha Identifier menu><CR><LF> +STGI: <Id1>,<NbItems>,<Alpha Id1 Label>,<Help Info>[,<NextActionId>]<CR><LF> +STGI: <Id2>,<NbItems>,<Alpha Id2 Label>,<Help Info>[,<NextActionId>]<CR><LF> [...] SIM expects an item choice (+STGR).
7	Get information about Refresh pro-active command.	+STGI: <RefreshType> No action (Refresh done automatically by product).
8	Get information about Send SS pro-active command.	+STGI:<TextInfo> No action (Send SS done automatically by product).
9	Get information about Send SMS pro-active command.	+STGI: <TextInfo> No action (Send SMS done automatically by product).
10	Get information about Send USSD pro-active command.	+STGI: <TextInfo> No action (Send USSD done automatically by product).
11	Get information about SETUP EVENT LIST pro-active command.	+STGI: <Evt>

Values for the SIM ToolKit Get Information Command:

Values when CmdType=0 (Setup menu)

<Alpha Identifier menu>	Alpha identifier of the main menu.
<Idx> (1-255)	Menu item Identifier.
<NbItems> (1-255)	Number of items in the main menu.
<Alpha Idx Label>	Alpha identifier label of items in ASCII format.
<HelpInfo>	
0:	No help information available.
1:	Help information available.
<NextActionId>	Contains a pro-active command identifier.(see the table in APPENDIX F)

Compared to other commands the customer application can always get information about setup menu after having received the +STIN:0 indication.

Values when CmdType=1 (Display text)

<Prior>	
0:	Normal priority of display.
1:	High priority of display.
<Text>	
Text to display in ASCII format.	
<ClearMode>	
0:	Clear message after a delay (3 seconds)
1:	Wait for user to clear message.

Values when CmdType=2 (Get Inkey)

<Format>	
0:	Digit (0-9, *, #, and +)
1:	SMS alphabet default.
2:	UCS2
<HelpInfo>	
0:	No help information available.
1:	Help information available.
<TextInfo>	
Text information in ASCII format.	

Values when CmdType=3 (Get Input)

<Format>	
0:	Digit (0-9, *, #, and +)
1:	SMS alphabet default.
2:	UCS2
3:	Unpacked format.
4:	Packed format.
<EchoMode>	
0:	Echo off.
1:	Echo on.
<SizeMin> (1-255)	
Minimum length of input.	
<SizeMax> (1-255)	
Maximum length of input.	
<HelpInfo>	
0:	No help information available.
1:	Help information available.
<TextInfo>	
Text information in ASCII format.	

Values when CmdType=4 (Setup Call)

<Type>	
0:	Set up call but only if not currently busy on another call.
1:	Set up call, putting all other calls (if any) on hold.
2:	Set up call, disconnecting all other calls (if any).
<CalledNb>	
Called party number in ASCII format.	
<SubAddress>	
Called party sub-address in ASCII format.	
<Class>	
0:	Voice call.
1:	Data call.
2:	Fax call

Values when CmdType=5 (Play tone)

<ToneType>	
0:	Tone Dial.
1:	Tone Busy.
2:	Tone Congestion.
3:	Tone Radio ack
4:	Tone Dropped.
5:	Tone Error.
6:	Tone Call waiting.
7:	Tone Ringing.
8:	Tone General beep.
9:	Tone Positive beep.
10:	Tone Negative beep.
<TimeUnit>	
0:	Time unit used is minutes.
1:	Time unit used is seconds.
2:	Time unit used is tenths of seconds.
<TimeInterval> (1-255)	
Time required expressed in units.	
<TextInfo>	
Text information in ASCII format.	

Values when CmdType=6 (Sel Item)

<DefaultItem> (1-255)	Default Item Identifier.
<Alpha Identifier menu>	Alpha identifier of the main menu.
<Idx> (1-255)	Identifier items.
<NbItems> (1-255)	Number of items in the menu.
<Alpha Idx Label>	Alpha identifier label of items in ASCII format.
<HelpInfo>	
0:	No help information available.
1:	Help information available.
<NextActionId>	Contains a pro-active command identifier. (see the table in APPENDIX F)

Values when CmdType=7 (Refresh)

<RefreshType>	
0:	SIM initialization and full file change notification.
1	File change notification.
2	SIM initialization and file change notification.
3	SIM initialization.
4	SIM reset.

Values when CmdType=8 (Send SS)

<TextInfo>	Text information in ASCII format.
------------	-----------------------------------

Values when CmdType=9 (Send SMS)

<TextInfo>	Text information in ASCII format.
------------	-----------------------------------

Values when CmdType=10 (Send USSD)

<TextInfo>	Text information in ASCII format.
------------	-----------------------------------

Values when CmdType=11 (Setup Event List)

<Evt>	
1:	Reporting asked for an 'Idle Screen' event.
2:	Reporting asked for an 'User Activity' event.
3:	Reporting asked for 'Idle Screen' and 'User Activity' events.
4:	Cancellation of reporting event.

Rem: For the UCS2 format texts are displayed in Hexa Ascii format. Example: When the SIM sends a TextString containing 0x00 0x41 the text displayed is "0041".

Error Codes for the SIM ToolKit Get Information Command:

+CME ERROR: 3	Operation not allowed. This error is returned when a wrong parameter is detected.
+CME ERROR: 4	Operation not supported. This error is returned when the user wants to get information about a SIM ToolKit pro-active command (with SIM ToolKit functionality not activated.)
+CME ERROR: 518	SIM ToolKit indication not received. This error is returned when the SIM ToolKit indication (+STIN) has not been received.

Example

Initially, all facilities are activated. The PIN is not required and SIM ToolKit functionality is activated.

```

AT+CMEE=1           Enable the reporting of mobile equipment errors
OK
AT+WIND=15         Set indications
OK
AT+STSF?
+STSF: 1,"5FFFFFFF7F",3   SIM ToolKit functionality activated with all facilities.
OK
+STIN: 0           The main menu has been sent from the SIM.
AT+STIN?
+STIN: 0
OK
AT+STGI=0         Get information about the main menu
+STGI: "SIM TOOLKIT MAIN MENU"   Main menu contains 3 items.
+STGI: 1,3,"BANK",0
+STGI: 2,3,"QUIZ",0
+STGI: 3,3,"WEATHER",0
OK
AT+STIN?
+CME ERROR: 4

```

Unsolicited Result: SIM ToolKit Control Response +STCR

Description:

When the customer application makes an outgoing call or an outgoing SMS and if the call control facility is activated, CALL CONTROL and SMS CONTROL responses can be identified. This is also applicable to SS calls.)

Values:

<Result>

0: Control response not allowed.

1: Control response with modification.

<Number> Called number, Service Center Address or SS String in ASCII format.

<MODestAddr> MO destination address in ASCII format.

<TextInfo> Text information in ASCII format.

Command Syntax: +STCR: <Result>[,<Number>,<MODestAddr>,<TextInfo>]

SIM ToolKit Give Response +STGR

Description:

This command allows the application/user to select an item in the main menu, or to answer the following proactive commands:)

- GET INKEY Key Pressed By The User.
- GET INPUT Message Entered By The User.
- SELECT ITEM Selected Item.
- SETUP CALL User Confirmation.
- DISPLAY TEXT User Confirmation To Clear The Message.
- SETUP EVENT LIST Reporting events.

It is also possible to terminate the current proactive command session by sending a Terminal Response to the SIM, with the following parameters:

- BACKWARD MOVE Process a backward move
- BEYOND CAPABILITIES Command beyond ME capabilities
- UNABLE TO PROCESS ME is currently unable to process command
- NO RESPONSE No response from the user
- END SESSION User abort.

Command syntax: +STGR=<CmdType>[,<Result>,<Data>]

Command	Possible responses
AT+STGR=<CmdType>[,<Result>,<Data>]	OK +CME ERROR: <err>
For GetInput with <Result>=1: AT+STGR=3,1<CR> <Data><Ctrl Z>	OK +CME ERROR: <err>
For GetInkey with <Result>=1 AT+STGR=2,1,"<Data>"	OK +CME ERROR: <err>
AT+STGR=?	OK

Values:**<CmdType>**

- 0:** Item selection in the main menu.
- 1:** User confirmation to clear a '**Disp Text**'.
- 2:** Response for a '**Get Inkey**'.
- 3:** Response for a '**Get Input**'.
- 4:** Response for a '**Setup call**'.
- 6:** Response for a '**Sel Item**'.
- 11** Reponse for a '**Setup event list**'.
- 95** Backward move
- 96** Command beyond ME capabilities
- 97** ME currently unable to process command
- 98** No response from the user.
- 99** User abort.

Values when CmdType=0 (Select an item from the main menu)**<Result>**

- 1:** Item selected by the user.
- 2:** Help information required by user.

<Data> Contains the item identifier of the item selected by the user.

Values when CmdType=1 (Confirm the display text clearing)

No values.

Values when CmdType=2 (Get Inkey)**<Result>**

- 0:** Session ended by user.
- 1:** Response given by the user.
- 2:** Help information required by user.

<Data> Contains the key pressed by the user.

Values when CmdType=3 (Get Input)**<Result>**

- 0:** Session ended by user.
- 1:** Response given by the user.
- 2:** Help information required by user.

<Data> Contains the string of characters entered by the user.

Note: For Inputs in UCS2 format, the data are entered in ASCII format. Example: For "8000410042FFFF" entered, the SIM receives 0x00 0x41 0x00 0x42 with UCS2 DCS. (See the Appendix G about the different UCS2 syntaxes).

Values when CmdType=4 (Setup call)**<Result>**

- 0:** User refuses the call.
- 1:** User accepts call.

Values when CmdType=6 (Select Item)**<Result>**

- 0:** Session terminated by the user
- 1:** Item selected by the user
- 2:** Help information required by the user
- 3:** Return to the back item

<Data> Contains the item identifier selected by the user

Values when CmdType=11 (Setup Event List)**<Result>**

- 1:** Idle screen available.
- 2:** User activity event.

Sending a Terminal Response to the SIM:

Values when CmdType=95 (**Backward Move**)

Values when CmdType=96 (**Command beyond ME capabilities**)

Values when CmdType=97 (**ME currently unable to process command**)

Values when CmdType=98 (**No response from the user**)

Values when CmdType=99 (**SIM ToolKit Session aborting by the user**)

No values.

It is possible to send a Terminal Response after the **+STIN** indication (step 2, of *Messages exchanged during a SIM ToolKit operation*), or after the **+STGI** command (step 3).

Note: For the SETUP MENU Proactive Command, it is only possible to send a Terminal Response after the **+STIN: 0** indication, not after a **+STGI=0** request. All of the Terminal Responses are not possible with all of the Proactive Commands. Compatibility between available Terminal Responses and Proactive Commands is given in Appendix D, Table 2. If a Terminal Response is attempted during a incompatible Proactive Command session, a **+CME ERROR: 3** will be returned.

Possible error codes

+ CME ERROR: 3 **Operation not allowed.** This error is returned when a wrong parameter is detected.
+CME ERROR: 4 **Operation not supported.** This error is returned when the user gives a response with SIM ToolKit functionality not activated. Or if the SIM ToolKit indication (**+STIN**) has not been received.

Example

Initially, all facilities are activated, the PIN is not required and the SIM ToolKit functionality is activated.

```
+STIN: 0                    The main menu has been sent from the SIM.
AT+STGI=0                 Get information about the main menu
+STGI: 1,3,"BANK",0       The main menu contains 3 items.
+STGI: 2,3,"QUIZ",0
+STGI: 3,3,"WEATHER",0
OK
AT+STGR=0,1,1             The item 2 of the main menu has been selected.
OK
+STIN: 6                   The Sel item menu has been sent from the SIM.
AT+STGI=6                 Get information about the BANK menu
+STGI: 1,"BANK"           The BANK menu contains two items.
+STGI: 1,2,"PERSONAL ACCOUNT ENQUIRY",1
+STGI: 2,2,"NEWS",0
OK
AT+STGR=6,1,1             Select Item 1.
OK
+STIN: 3                   User request to enter Password sent.
AT+STGI=3                 Get information about this request.
+STGI: 0,0,4,4,0,"Enter Account Password:"
OK
AT+STGR=3,1<CR>           The user enters the Password.
>0000<Ctrl Z>
OK
+STIN:1                    A text info has been sent from the SIM.
AT+STGI=1                 Get information about this text.
+STGI: 0,"Password correct, please wait for response",0
OK
+STIN: 9                   SIM requests a bank account update from bank server via the network (SEND SMS)
AT+STGI=9                 Get all information about the SEND SMS
+STGI: "Send account balance of user, authorization ok"
OK

***** After a short period of time. *****
+STIN: 5                   Transaction is complete: BEEP
+STGI=5                   Get information about the Tone
+STGI: 9,1,1
+STIN: 1                   Display text indication
AT+STGI=1
+STGI: 0,"Your account balance is 1000 $",0
OK
```

CHAPTER 17 - GPRS COMMANDS

When using GSM-only software, GPRS commands are not available.

Define PDP Context **+CGDCONT**

Description:

This command specifies PDP context parameter values for a PDP context identified by the local context identification parameter, <cid>.

Four PDP contexts can be defined.

A special form of the set command, +CGDCONT= <cid> causes the values for context number <cid> to become undefined.

The test command returns values supported as a compound value. If the modem supports several PDP types, <PDP_type>, the parameter value ranges for each <PDP_type> are returned on a separate line.

The read command returns the current settings for each defined context.

The test command returns values supported as a compound value. If the modem supports several PDP types, <PDP_type>, the parameter value ranges for each <PDP_type> are returned on a separate line.

Values:

<cid>: (PDP Context Identifier) a numeric parameter (1-4) which specifies a particular PDP context definition. The parameter is local to the DTE-modem interface and is used in other PDP context-related commands.

<PDP_type>: (Packet Data Protocol type) a string parameter which specifies the type of packet data protocol

- IP Internet Protocol
- PPP Point to Point Protocol

<APN>: (Access Point Name) a string parameter, which is a logical name that is used to select the GGSN or the external packet data network. If the value is null or omitted, then the subscription value will be requested.

<PDP_address>: a string parameter that identifies the modem in the address space applicable to the PDP. If the value is null or omitted, then a value may be provided by the DTE during the PDP startup procedure or, failing that, a dynamic address will be requested. The read form of the command will continue to return the null string even if an address has been allocated during the PDP startup procedure. The allocated address may be read using the **+CGPADDR** command.

<d_comp>: a numeric parameter that controls PDP data compression

- 0: Off (default if value is omitted)
 - 1: On
- Other values are reserved.

<h_comp>: a numeric parameter that controls PDP header compression

- 0: Off (default if value is omitted)
 - 1: On
- Other values are reserved.

Notes:

- At present only one data compression algorithm (V.42bis) is provided in SNDCP. If and when other algorithms become available, a command will be provided to select one or more of these.
- 32 cids are available to specify 32 PDP contexts but only 11 NSAPI are available for PDP activation. Four PDP contexts can be specified with only one activated at the same time.

Command Syntax:

Command	Possible responses
AT+CGDCONT=[<cid> [,<PDP_type> [,<APN> [,<PDP_addr> [,<d_comp> [,<h_comp>]]]]]]	OK ERROR
AT+CGDCONT?	+CGDCONT: <cid>, <PDP_type>, <APN>, <PDP_addr>, <data_comp>, <head_comp> [<CR><LF>+CGDCONT: <cid>, <PDP_type>, <APN>, <PDP_addr>, <data_comp>, <head_comp> [...]] OK
AT+CGDCONT=?	+CGDCONT: (range of supported <cid>s), <PDP_type>,,,(list of supported <d_comp>s), (list of supported <h_comp>s) [<CR><LF>+CGDCONT: (range of supported <cid>s), <PDP_type>,,,(list of supported <d_comp>s), (list of supported <h_comp>s) [...]] OK
AT+CGDCONT: 1, "IP" "internet"; AT+CGCONT=?	+CGCONT: (1-4), "IP" ,,,(0-1,(0-1) +CGCONT: (1-4), "PPP" ,,,0,0,0 OK
AT+CGCONT?	+CGCONT: 1, "IP","internet",,0,0 +CGCONT: 2, "IP","abc.com",,0,0 OK

Quality of Service Profile Requested +CGQREQ

Description:

This command allows the DTE to specify a Quality of Service Profile that is used when the modem sends an Activate PDP Context Request message to the network.

The set command specifies a profile for the context identified by the local context identification parameter, <cid>. Since this is the same parameter that is used in the +CGDCONT command, the +CGQREQ command is effectively an extension to the +CGDCONT command. The QoS profile consists of a number of parameters, each of which may be set to a separate value.

A special form of the set command, +CGQREQ= <cid>, causes the requested profile for context number <cid> to become undefined.

The read command returns the current settings for each defined context. The test command returns values supported as a compound value. If the modem supports several PDP types, the parameter value ranges for each PDP type are returned on a separate line.

Command Syntax:

Command	Possible Response(s)
AT+CGQREQ=[<cid> [,<precedence > [,<delay> [,<reliability.> [,<peak> [,<mean>]]]]]]	OK ERROR
AT+CGQREQ?	+CGQREQ: <cid>, <precedence >, <delay>, <reliability>, <peak>, <mean> [<CR><LF>+CGQREQ: <cid>, <precedence >, <delay>, <reliability.>, <peak>, <mean> [...]] OK
AT+CGQREQ=?	+CGQREQ: <PDP_type>, (list of supported <precedence>s), (list of supported <delay>s), (list of supported <reliability>s) , (list of supported <peak>s), (list of supported <mean>s) [<CR><LF>+CGQREQ: <PDP_type>, (list of supported <precedence>s), (list of supported <delay>s), (list of supported <reliability>s) , (list of supported <peak>s), (list of supported <mean>s) [...]] OK
AT +CGQREQ=1,1,4,5,2,14	OK
AT+CGQREQ=?	+CGQREQ: "IP", (1-3), (1-4), (1-5), (1-9), (1-31) +CGQREQ: "PPP", (1-3), (1-4), (1-5), (1-9), (1-31) OK
AT+CGQREQ?	+CGQREQ: 1,1,4,5,2,14 OK

Summary List of Values:

<cid>: a numeric parameter that specifies a particular PDP context definition.

<precedence>: a numeric parameter that specifies the precedence class

<delay>: a numeric parameter that specifies the delay class

<reliability>: a numeric parameter that specifies the reliability class

<peak>: a numeric parameter that specifies the peak throughput class

<mean>: a numeric parameter that specifies the mean throughput class

Note: If a value is omitted for a particular class then the value is considered to be unspecified.

Details about Values:

<cid> Range 1- 3

<precedence>

0: Subscribed precedence - Subscribed by the Network by default if value is omitted

1: High priority - Service commitments shall be maintained ahead of precedence classes 2 and 3

2: Normal priority - Service commitments shall be maintained ahead of precedence class 3

3: Low priority - Service commitments shall be maintained after precedence classes 1 and 2

<delay>

0: Subscribed

1: Delay class 1

2: Delay class 2

3: Delay class 3

4: Delay class 4

Delay Class	Delay (maximum values)			
	SDU size: 128 bytes		SDU size: 1024 bytes	
	Mean Transfer Delay (sec)	95 percentile Delay (sec)	Mean Transfer Delay (sec)	95 percentile Delay (sec)
1. (Predictive)	Subscribed	Subscribed by the Nwk / default if value is omitted		
2. (Predictive)	< 0.5		< 2	< 7
3. (Predictive)	< 5	< 25	< 15	< 75
4. (Best Effort)	< 50	< 250	< 75	< 375
	Unspecified			

<reliability>

- 0: Subscribed
- 1: Up to 1 000 (8 kbit/s)
- 2: Up to 2 000 (16 kbit/s)
- 3: Up to 4 000 (32kbit/s)
- 4: Up to 8 000 (64 kbit/s)
- 5: Up to 16 000 (188 kbit/s)
- 6: Up to 32 000 (256 kbit/s)
- 7: Up to 64 000 (512 kbit/s)
- 8: Up to 128 000 (1 024 kbit/s)
- 9: Up to 256 000 (2 048 kbit/s)

Reliability Class	GTP Mode	LLC Frame Mode	LLC Data Protection	RLC Block Mode	Traffic Type
0	Subscribed	Subscribed by the Nwk / default if value is omitted			
1	Acknowledged	Acknowledged	Protected	Acknowledged	Non real-time traffic, error-sensitive application that cannot cope with data loss.
2	Unacknowledged	Acknowledged	Protected	Acknowledged	Non real-time traffic, error-sensitive application that can cope with infrequent data loss.
3	Unacknowledged	Unacknowledged	Protected	Acknowledged	Non real-time traffic, error-sensitive application that can cope with data loss, GMM/SM, & SMS.
4	Unacknowledged	Unacknowledged	Protected	Unacknowledged	Real-time traffic, error-sensitive application that can cope with data loss.
5	Unacknowledged	Unacknowledged	Unprotected	Unacknowledged	Real-time traffic, error non-sensitive application that can cope with data loss.
Note: For real-time traffic, the QoS profile also requires appropriate settings for delay and throughput.					

<peak>

- 0: Subscribed
- 1: Up to 1 000 (8 kbit/s)
- 2: Up to 2 000 (16 kbit/s)
- 3: Up to 4 000 (32kbit/s)
- 4: Up to 8 000 (64 kbit/s)
- 5: Up to 16 000 (188 kbit/s)
- 6: Up to 32 000 (256 kbit/s)
- 7: Up to 64 000 (512 kbit/s)
- 8: Up to 128 000 (1 024 kbit/s)
- 9: Up to 256 000 (2 048 kbit/s)

<mean>

- 0: Subscribed by the Network by default if value is omitted
- 1: 100 (~0.22 bit/s)
- 2: 200 (~0.44 bit/s)
- 3: 500 (~1.11 bit/s)
- 4: 1 000 (~2.2 bit/s)
- 5: 2 000 (~4.4 bit/s)
- 6: 5 000 (~11.1 bit/s)
- 7: 10 000 (~22 bit/s)
- 8: 20 000 (~44 bit/s)
- 9: 50 000 (~111 bit/s)
- 10: 100 000 (~0.22 kbit/s)
- 11: 200 000 (~0.44 kbit/s)
- 12: 500 000 (~1.11 kbit/s)
- 13: 1 000 000 (~2.2 kbit/s)
- 14: 2 000 000 (~4.4 kbit/s)
- 15: 5 000 000 (~11.1 kbit/s)
- 16: 10 000 000 (~22 kbit/s)
- 17: 20 000 000 (~44 kbit/s)
- 18: 50 000 000 (~111 kbit/s)
- 31: Best effort

Quality of Service Profile Minimum Acceptable +CGQMIN

Description:

This command allows the DTE to specify a minimum acceptable profile which is checked by the modem against the negotiated profile returned in the Activate PDP Context Accept message.

The set command specifies a profile for the context identified by the local context identification parameter, <cid>. Since this is the same parameter that is used in the +CGDCONT command, the +CGQMIN command is effectively an extension to the +CGDCONT command. The QoS profile consists of a number of parameters, each of which may be set to a separate value.

A special form of the set command, +CGQMIN= <cid> causes the minimum acceptable profile for context number <cid> to become undefined. In this case no check is made against the negotiated profile.

The read command returns the current settings¹ for each defined context. The test command returns values supported as a compound value. If the modem supports several PDP types, the parameter value ranges for each PDP type are returned on a separate line.

Values:

<cid>: a numeric parameter which specifies a particular PDP context .

<precedence>: a numeric parameter which specifies the precedence class.

<delay>: a numeric parameter which specifies the delay class.

<reliability>: a numeric parameter which specifies the reliability class.

<peak>: a numeric parameter which specifies the peak throughput class.

<mean>: a numeric parameter which specifies the mean throughput class.

Note: If a value is omitted for a particular class then this class is not checked.

Command Syntax:

Command	Possible Response(s)
AT+CGQMIN=[<cid> [,<precedence> [,<delay> [,<reliability> [,<peak> [,<mean>]]]]]]	OK ERROR
AT+CGQMIN?	+CGQMIN: <cid>, <precedence>, <delay>, <reliability>, <peak>, <mean> [<CR><LF>+CGQMIN: <cid>, <precedence>, <delay>, <reliability>, <peak>, <mean> [...]] OK
AT+CGQMIN=?	+CGQMIN: <PDP_type>, (list of supported <precedence>s), (list of supported <delay>s), (list of supported <reliability>s), (list of supported <peak>s), (list of supported <mean>s) [<CR><LF>+CGQMIN: <PDP_type>, (list of supported <precedence>s), (list of supported <delay>s), (list of supported <reliability>s), (list of supported <peak>s), (list of supported <mean>s) [...]] OK
AT+CGQMIN = 1,1,4,5,2,31	OK
AT+CGQMIN=?	+CGQMIN: "IP", (1-3), (1-4), (1-5), (1-9), (1-31) +CGQMIN: "PPP", (1-3), (1-4), (1-5), (1-9), (1-31) OK
AT+CGQMIN?	+CGQMIN=? 1,1,4,5,2,14 OK

GPRS Attach or Detach +CGATT

Description:

The execution command is used to attach the modem to, or detach the modem from, the GPRS service. After the command has completed, the modem remains in V.25ter command state. If the modem is already in the requested state, the command is ignored and the OK response is returned. If the requested state cannot be achieved, an ERROR or +CME ERROR response is returned. Extended error responses are enabled by the +CMEE command.

Any active PDP contexts will be automatically deactivated when the attachment state changes to detached.

The read command returns the current GPRS service state. The test command is used for requesting information on the supported GPRS service states.

Values:

<state>: indicates the state of GPRS attachment

0: Detached

1: Attached

Other values are reserved and will result in an ERROR response to the execution command.

Command Syntax:

Command	Possible Responses
AT+CGATT= [<state>]	OK ERROR
AT+CGATT?	+CGATT: <state> OK
AT+CGATT=?	+CGATT: (list of supported <state>s) OK
AT+CGATT=1	OK

PDP Context Activate or Deactivate +CGACT

Description:

The execution command activates or deactivates the specified PDP context (s). After the command has completed, the modem remains in V.25ter command state. If any PDP context is already in the requested state, the state for that context remains unchanged.

If the requested state for any specified context cannot be achieved, an ERROR or +CME ERROR response is returned. Extended error responses are enabled by the +CMEE command.

If the modem is not GPRS attached when the activation form of the command is executed, the modem first performs a GPRS attach and then attempts to activate the specified contexts. If the attach fails then the modem responds with ERROR or, if extended error responses are enabled, with the appropriate failure-to-attach error message.

If no <cid>s are specified the activation form of the command activates the first activable defined contexts. If no <cid>s are specified the deactivation form of the command deactivates all active contexts.

One PDP context can be activated at the same time.

The read command returns the current activation states for all the defined PDP contexts.

The test command is used for requesting information on the supported PDP context activation states.

Values:

<state>: indicates the state of PDP context activation

0: Deactivated

1: Activated

Other values are reserved and will result in an ERROR response to the execution command.

<cid>: a numeric parameter which specifies a particular PDP context.

Before a context can be activated, the modem must be attached to the GPRS network by performing an automatic GPRS attach.

Command Syntax:

Command	Possible Response(s)
AT+CGACT=[<state> [,<cid>[,<cid>[,...]]]]	OK ERROR
AT+CGACT?	+CGACT: <cid>, <state> [<CR><LF>+CGACT: <cid>, <state> [...]] OK
AT+CGACT=?	+CGACT: (list of supported <state>s) OK
AT+CGACT=1,1	OK
AT+CGACT?	+CGACT: 1,1 OK
AT+CGACT=?	+CGACT: (0-1) OK

Enter Data State +CGDATA

Description:

The command causes the modem to perform the necessary actions to set up communication between the DTE and the network. This may include performing a GPRS attach and one PDP context activations.

If the <cid> value is not defined to the modem, the modem will return an ERROR or +CME ERROR response. Otherwise, the modem issues the intermediate result code CONNECT and enters V.25ter online data state.

GPRS attachment and PDP context activation procedures may take place prior to or during the PDP startup if they have not already been performed using the **+CGATT** and **+CGACT** commands.

If no <cid> is given, the modem attempts to activate the context with whatever information is available to the modem. The other context parameters is set to their default values (No APN, default QOS parameters, dynamic IP address requested).

If the activation is successful, data transfer may proceed.

After data transfer and layer 2 protocol termination procedure completion, the V.25ter command state is re-entered and the modem returns the final result code OK.

In case of an abnormal termination or start up, the V.25ter command state is re-entered and the modem returns the final result code NO CARRIER or, if enabled, +CME ERROR. Attach, activate and other errors may be reported.

This command may be used in both normal and modem compatibility modes.

Note: The goal of this command is the same than ATD*99***.

Values:

<cid>: a numeric parameter which specifies a particular PDP context definition.

Command Syntax:

Command	Possible Response(s)
AT+CGDATA=[<cid>]	CONNECT ERROR
AT+CGDATA=?	+CGDATA: OK
AT+CGDATA=?	+CGDATA: OK
AT+CGDATA=1	CONNECT

GPRS Mobile Station Class +CGCLASS

Description:

The set command is used to set the modem to operate according to the specified GPRS mobile class. If the requested class is not supported, an ERROR or +CME ERROR response is returned.

The read command returns the current GPRS mobile class.

The test command is used for requesting information on the supported GPRS mobile classes.

Defined Values:

<class>: a string parameter which indicates the GPRS mobile class (in descending order of functionality)

- A** class A (highest)
- B** class B
- CG** class C in GPRS only mode
- CC** class C in circuit switched only mode (lowest)

Other values are reserved and will result in an ERROR response to the set command.

If the modem is GPRS attached when the set command is issued with a <class> = CC specified, a GPRS detach request is sent to the network. If the modem is GSM attached when the set command is issued with a <class> = CG specified, a GSM detach request is sent to the network.

Class A is not supported.

Note: During switch-On in CG class, the modem always performs an automatic GPRS attach (the ATTACH-STATUS parameter of +WGPRS is ignored). But if the modem is not already GPRS- attached when switching from B/CC class to CG class, then no automatic GPRS attach is performed.

About of the automatic attachment (see Note above):

```
AT+CGCLASS?
+CGCLASS: "B"
OK
AT+CGATT?
+CGATT: 0
OK
AT+CGCLASS="CG"
OK
AT+CGATT?
+CGATT: 0
OK
AT+CGATT=1
OK
AT+CPOF
OK
AT+CFUN=1
OK
AT+CGCLASS?
+CGCLASS: "CG"
OK
AT+CGATT?
+CGATT: 1
OK
```

Command Syntax:

Command	Possible Response(s)
AT+CGCLASS= [<class>]	OK ERROR
AT+CGCLASS?	+CGCLASS: <class> OK
AT+CGCLASS=?	+CGCLASS: (list of supported <class>s) OK
AT+CGCLASS="CG" <i>Note: Enter GPRS Class C mode</i>	OK
AT+CGCLASS="CC" <i>Note: Enter GMS mode</i>	OK
AT+CGCLASS="A" <i>Note: Chosen class not supported</i>	+CME ERROR: 150
AT+CGCLASS=?	+CGCLASS: ("CG","CC") OK
AT+CGCLASS?	+CGCLASS: ("CC") OK

Select Service for MO SMS Messages +CGSMS

Description:

The set command specifies the service or service preference that the modem will use to send MO SMS messages.

The read command returns the currently selected service or service preference.

The test command requests information on the currently available services and service preferences.

Values:

<service>: a numeric parameter which indicates the service or service preference to be used

0: GPRS

1: Circuit switched

2: GPRS preferred (use circuit switched if GPRS is not available)

3: Circuit switched preferred (use GPRS if circuit switched not available)

Other values are reserved and will result in an ERROR response to the set command.

Command Syntax:

Command	Possible Responses
AT+CGSMS= [<service>]	OK ERROR
At+CGSMS?	+CGSMS: <service> OK
AT+CGSMS=?	+CGSMS: (list of currently available <service>s) OK
AT +CGSMS=0	OK
AT+CGSMS=?	+CGSMS=(0-3) OK

GPRS Event Reporting +CGEREP

Description:

Set command enables or disables sending of unsolicited result codes, +CGEV: XXX from modem to DTE in the case of certain events occurring in the GPRS modem or the network.

<mode> controls the processing of unsolicited result codes specified within this command.

Read command returns the current mode and buffer settings.

Test command returns the modes and buffer settings supported by the modem as compound values.

Values:

<mode>:

0: Buffer unsolicited result codes in the modem; if modem result code buffer is full, the oldest ones can be discarded. No codes are forwarded to the DTE.

2: Buffer unsolicited result codes in the modem when modem-DTE link is reserved (e.g. in on-line data mode) and flush them to the DTE when modem-DTE link becomes available; otherwise forward them directly to the DTE.

<bfr>

0: Modem buffer of unsolicited result codes defined within this command is cleared when <mode> 1 or 2 is entered. This is the only case supported.

1: Modem buffer of unsolicited result codes defined within this command is flushed to the DTE when <mode> 2 is entered. This case is not supported.

The software provides a combination of all modes. When a serial link is available, indications are forwarded directly to the DTE. If a serial link is reserved (e.g., in on-line data mode) or the modem result code buffer is full, the oldest ones can be discarded.

Command Syntax:

Command	Possible Responses
AT+CGEREP=[<mode>]	OK ERROR
AT+CGEREP?	+CGEREP: <mode>,<bfr> OK
AT+CGEREP=?	+CGEREP: (list of supported <mode>s), (list of supported <bfr>s) OK

Result Codes and Corresponding Events:

The following unsolicited result codes and the corresponding events are defined:

+CGEV: REJECT <PDP_type>, <PDP_addr>

A network request for PDP context activation occurred when the modem was unable to report it to the DTE with a +CRING unsolicited result code and was automatically rejected.

+CGEV: NW REACT <PDP_type>, <PDP_addr>, [<cid>]

The network has requested a context reactivation. The <cid> that was used to reactivate the context is provided if known to the modem.

+CGEV: NW DEACT <PDP_type>, <PDP_addr>, [<cid>]

The network has forced a context deactivation. The <cid> that was used to activate the context is provided if known to the modem.

+CGEV: ME DEACT <PDP_type>, <PDP_addr>, [<cid>]

The mobile equipment has forced a context deactivation. The <cid> that was used to activate the context is provided if known to the modem.

+CGEV: NW DETACH

The network has forced a GPRS detach. This implies that all active contexts have been deactivated. These are not reported separately.

+CGEV: ME DETACH

The mobile equipment has forced a GPRS detach. This implies that all active contexts have been deactivated. These are not reported separately.

+CGEV: NW CLASS <class>

The network has forced a change of MS class. The highest available class is reported.

+CGEV: ME CLASS <class>

The mobile equipment has forced a change of MS class. The highest available class is reported.

GPRS Network Registration Status +CGREG

Description:

The set command controls the presentation of an unsolicited result code +CGREG: <stat> when <n>=1 and there is a change in the modem's GPRS network registration status, or code +CGREG: <stat>[,<lac>,<ci>] when <n>=2 and there is a change of the network cell.

The read command returns the status of result code presentation and an integer <stat> which shows whether the network has currently indicated the registration of the modem. Location information elements <lac> and <ci> are returned only when <n>=2 and modem is registered in the network.

Values:

<n>

- 0: Disable network registration unsolicited result code
- 1: Enable network registration unsolicited result code +CGREG: <stat>
- 2: Enable network registration and location information unsolicited result code +CGREG: <stat>[,<lac>,<ci>]

<stat>

- 0: Not registered; the modem is not currently searching a new operator to which to register
- 1: Registered, home network
- 2: Not registered, but modem is currently searching a new operator to which to register
- 3: Registration denied
- 4: Unknown
- 5: Registered, roaming

<lac>

String type; two byte location area code in hexadecimal format

<ci>

String type; two byte cell ID in hexadecimal format

Command Syntax:

Command	Possible response(s)
AT+CGREG=[<n>]	+CGREG: stat>[,<lac>,<ci>] OK
AT+CGREG?	+CGREG: <n>,<stat>[,<lac>,<ci>] OK <i>Note: +CME ERROR: <err></i>
AT+CGREG=?	+CGREG: (list of supported <n>s) OK

Request GPRS IP Service D

Description:

This command causes the modem to perform whatever actions are necessary to establish communication between the DTE and the external PDN.

The V.25ter 'D' (Dial) command causes the modem to enter the V.25ter online data state and, with the DTE, to start the specified layer 2 protocol. The modem return CONNECT to confirm acceptance of the command prior to entering the V.25ter online data state. No further commands may follow on the AT command line.

The detailed behavior after the online data state has been entered is described briefly in clause 9, for IP, of GSM 07.60. GPRS attachment and PDP context activation procedures may take place prior to or during the PDP startup if they have not already been performed using the +CGATT and +CGACT commands.

If <cid> is supported, its usage is the same as in the +CGDATA command. The +CGDCONT, +CGQREQ, etc. commands may then be used in the modem initialization AT command string to set values for for PDP type, APN, QoS etc...

If <cid> is not supported or is supported but omitted, the modem attempt to activate the context using the 'Empty PDP type' (GSM 04.08). (No PDP address or APN is sent in this case and only one PDP context subscription record is present in the HLR for this subscriber.)

Values:

<GPRS_SC_IP>: (GPRS Service Code for IP) a digit string (value 99), which identifies a request to use the GPRS with IP (PDP types IP and PPP)

<cid>: a digit string which specifies a particular PDP context definition.

Command Syntax:

Command	Possible Responses
D* <GPRS_SC_IP> [***<cid>]#	CONNECT ERROR

Example

```
ATD*99***1#
CONNECT
ATD*99***2#
ERROR
```

Network Requested PDP Context Activation

In this mode of operation, the modem behaves like an answering modem and accepts the normal V.25ter commands associated with answering a call. If GPRS-specific configuration commands are required, they may be sent to the modem as part of the modem initialization commands. The +CGAUTO command is used to select modem compatibility mode.

Automatic response to a network request for PDP context activation S0

The V.25ter 'S0=n' (Automatic answer) command may be used to turn off (n=0) and on (n>0) the automatic response to a network request for a PDP context activation. When the 'S0=n' (n>0) command is received, the modem attempt to perform a GPRS attach if it is not already attached. Failure will result in ERROR being returned to the DTE. Subsequently, the modem will announce a network request for PDP context activation by issuing the unsolicited result code RING to the DTE, followed by the intermediate result code CONNECT. The modem then enters V.25ter online data state and follows the same procedure as it would after having received a +CGANS=1 with no <L2P> or <cid> values specified.

Note: The 'S0=n' (n=0) command does not perform an automatic GPRS detach.

Manual acceptance of a network request for PDP context activation A

The V.25ter 'A' (Answer) command may be used to accept a network request for a PDP context activation announced by the unsolicited result code RING. The modem responds with CONNECT, enters V.25ter online data state and follows the same procedure as it would after having received a +CGANS=1 with no <cid> value specified. It is an error to issue the 'A' command when there is no outstanding network request.

Manual rejection of a network request for PDP context activation H

The V.25ter 'H' or 'H0' (On-hook) command may be used to reject a network request for PDP context activation announced by the unsolicited result code RING. The modem responds with OK. It is an error to issue the 'H' command when there is no outstanding network request.

Note: This is an extension to the usage of the 'H' command that is described in ITU-T V.25ter.

Automatic Response to a Network Request for PDP Context Activation +CGAUTO

Description:

The set command disables or enables an automatic positive response (auto-answer) to the receipt of a Request PDP Context Activation message from the network. It also provides control over the use of the V.25ter basic commands 'S0', 'A' and 'H' for handling network requests for PDP context activation. The setting does not affect the issuing of the unsolicited result code RING or +CRING.

The test command returns values of <n> supported by the modem as a compound value.

When the +CGAUTO=0 command is received, the modem will not perform a GPRS detach if it is attached. Subsequently, when the modem announces a network request for PDP context activation by issuing the unsolicited result code RING or +CRING, the DTE may manually accept or reject the request by issuing the +CGANS command or may simply ignore the network request.

When the +CGAUTO=1 command is received, the modem will attempt to perform a GPRS attach if it is not already attached. Failure will result in ERROR or, if enabled, +CME ERROR being returned to the DTE. Subsequently, when the modem announces a network request for PDP context activation by issuing the unsolicited result code RING or +CRING to the DTE, this is followed by the intermediate result code CONNECT. The modem then enters V.25ter online data state and follows the same procedure as it would after having received a +CGANS=1 with <cid> values specified.

Values:

<n>:

- 0:** Turn off automatic response for GPRS only
For <n> = 0 GPRS network requests are manually accepted or rejected by the +CGANS command.
- 1:** Turn on automatic response for GPRS only
For <n> = 1 GPRS network requests are automatically accepted according to the description above.
- 2:** Modem compatibility mode, GPRS only
For <n> = 2, automatic acceptance of GPRS network requests is controlled by the 'S0' command. Manual control uses the 'A' and 'H' commands, respectively, to accept and reject GPRS requests. (+CGANS may also be used.) Incoming circuit switched calls can be neither manually nor automatically answered
- 3:** Modem compatibility mode, GPRS and circuit switched calls (default)
For <n> = 3, automatic acceptance of both GPRS network requests and incoming circuit switched calls is controlled by the 'S0' command. Manual control uses the 'A' and 'H' commands, respectively, to accept and reject GPRS requests. (+CGANS may also be used.) Circuit switched calls are handled as described elsewhere in this specification.

Note: In class C GPRS the modem can't receive GPRS and GSM incoming calls simultaneously.

Command Syntax:

Command	Possible response(s)
AT+CGAUTO=[<n>]	OK ERROR
AT+CGAUTO?	+CGAUTO: <n> OK
AT+CGAUTO=?	+CGAUTO: (0-3) OK

Example:

```
AT+CGAUTO=?
+CGAUTO: (0-2)
OK
AT+CGAUTO?
+CGAUTO: 2
OK
AT+CGAUTO=0
OK
```

Manual Response to a Network Request for PDP Context Activation +CGANS

Description:

The execution command requests the modem to respond to a network request for GPRS PDP context activation which has been signalled to the DTE by the RING or +CRING: unsolicited result code. The <response> parameter allows the DTE to accept or reject the request.

If <response> is 0, the request is rejected and the modem returns OK to the DTE.

If <response> is 1, the following procedure is followed by the modem.

PDP context activation procedures take place prior to or during the PDP startup.

One <cid> may be specified in order to provide the values needed for the context activation request.

During the PDP startup procedure the modem has the PDP type and the PDP address provided by the network in the Request PDP Context Activation message.

If a <cid> is given his informations must matching with the PDP type and PDP address in the network request as follows -

The PDP type must match exactly.

The PDP addresses are considered to match if they are identical or if the address in the context definition is unspecified. If any of this information is in conflict, the command will fail.

The context is activated using the values for PDP type and PDP address provided by the network, together with the other information found in the PDP context definition. An APN may or may not be required, depending on the application. If no <cid> is given, the modem will attempt to activate the context using the values for PDP type and PDP address provided by the network, together with any other relevant information known to the modem. The other context parameters will be set to their default values.

If the activation is successful, data transfer may proceed. After data transfer is complete, and the layer 2 protocol termination procedure has completed successfully, the V.25ter command state is re-entered and the modem returns the final result code OK.

In the event of an erroneous termination or a failure to startup, the V.25ter command state is re-entered and the modem returns the final result code NO CARRIER or, if enabled, +CME ERROR. Attach, activate and other errors may be reported. It is also an error to issue the +CGANS command when there is no outstanding network request.

This command may be used in both normal and modem compatibility modes.

Values:

<response>: is a numeric parameter which specifies how the request should be responded to.

0: reject the request

1: accept and request that the PDP context be activated

If <response> is omitted it is assumed to be 0. Other values are reserved and will result in the ERROR response.

<cid>: a numeric parameter which specifies a particular PDP context definition.

Command Syntax:

Command	Possible response(s)
AT+CGANS=[<response>, [<cid>]]	OK ERROR
AT+CGANS=?	+CGANS: (list of supported <response>s), (list of supported <L2P>s) OK

Example:

```
+CRING: GPRS "IP", "122.41.74.238"
AT+CGANS=1
CONNECT
AT+CGANS=?
+CGANS= (0-1)
OK
```

Show PDP Address +CGPADDR

Description:

The execution command returns a list of PDP addresses for the specified context identifiers.

The test command returns a list of defined <cid>s.

Values:

<cid>: A numeric parameter which specifies a particular PDP context definition. If no <cid> is specified, the addresses for all defined contexts are returned.

<PDP_address>: A string that identifies the modem in the address space applicable to the PDP. The address may be static or dynamic. For a static address, it will be the one set by the +CGDCONT command when the context was defined. For a dynamic address it will be the one assigned during the last PDP context activation that used the context definition referred to by <cid>. <PDP_address> is omitted if none is available.

Command Syntax:

Command	Possible response(s)
AT+CGPADDR=[<cid> [,<cid> [...]]]	+CGPADDR: <cid>,<PDP_addr> [<CR><LF>+CGPADDR: <cid>,<PDP_addr> [...]] OK
AT+CGPADDR=?	+CGPADDR: (list of defined <cid>s) OK

Example:

In this example, 3 <cid>s are defined:

```
AT+CGPADDR=1
+CGPADDR=1,"107.210.5.4"
OK
AT+CGPADDR=?
+CGPADDR= (1-32)
OK
AT+CGPADDR
+CGPADDR: 1,
+CGPADDR: 2,"10.3.73.151"
+CGPADDR: 3,
+CGPADDR: 4,
```

Cellular Result Codes +CRC

Description:

This command enables a more detailed ring indication, in case of incoming call (voice or data). Instead of the string "RING", an extended string is used to indicate which type of call is ringing (e.g. +CRING: VOICE).

These extended indications are:

+CRING: ASYNC	for asynchronous transparent
+CRING: REL ASYNC	for asynchronous non-transparent
+CRING: VOICE	for normal speech.
+CRING: FAX	for fax calls
+CRING: GPRS	GPRS network request for PDP context activation

If the modem is unable to announce to the DTE the network's request (for example it is in V.25ter online data state) the modem reject the request. No corresponding unsolicited result code is issued when the modem returns to a command state.

Values: No parameters

Command Syntax:

Command	Possible responses
AT+CRC=0 <i>Note: Extended reports disabled</i>	OK <i>Note: Command valid</i>
AT+CRC=1 <i>Note: Extended reports enabled</i>	OK <i>Note: Command valid</i>
AT+CRC?	+CRC: 1 OK
AT+CRC=?	+CRC: (0,1) OK

Service Reporting Control +CR

Description:

This command enables a more detailed service reporting for incoming or outgoing calls. Before sending the CONNECT response to the application, the GSM module will precisely define the type of data connection being established.

These report types are:

+CR: ASYNC	For asynchronous transparent
+CR: REL ASYNC	For asynchronous non-transparent
+CR: GPRS	For GPRS

Values: No parameters

Command syntax: **AT+CR**

Command	Possible responses
AT+CR=0 <i>Note: Extended reports disabled</i>	OK <i>Note: Command valid</i>
AT+CR=1 <i>Note: Extended reports enabled</i>	OK <i>Note: Command valid</i>

Extended Error Report +CEER

Description:

This command gives the reason of the call release when the last call setup (originating or answering) failed. New indication for GPRS is the reason of the last unsuccessful PDP context activation and the last GPRS detach or PDP context activation.

Values: No parameters

Command Syntax: **AT+CEER**

Command	Possible Responses
ATD123456789 ; <i>Note: Outgoing voice call</i>	NO CARRIER <i>Note: Call setup failure</i>
AT+CEER <i>Note: Ask for reason of release</i>	+CEER: Error <xxx> OK <i>Note: <xxx>is the cause information element values form GSM recommendation 04.08 or specific Call accepted</i>

“NO CARRIER” indicates that the AT+CEER information is available for a failure diagnostic. See *Failure Cause from GSM 04.08 Recommendation* in Appendix A.

GPRS Parameters Customization +WGPRS

Description:

This command modifies some of the GPRS parameters, such as the ATTACH-STATUS (the modem doesn't automatically make a GPRS attachment after initialization), the PDP-INIT-STATUS (activate automatically some defined PDP Contexts after initialization) and the use of NAT (IP address translation on PPP). In addition, this command permits the automatic setting of some PDP contexts after initialization.

Note: The modem must be rebooted to activate the new setup.

Values:

<mode>: a numeric parameter which specifies a GPRS parameter:

- 0: ATTACH-STATUS (the modem doesn't automatically make a GPRS attachment after init)
- 1: PDP-INIT-STATUS (automatically activate some define PDP Contexts after init)
- 2: Set ACTIVABLE automatically after init a define PDP context
- 3: NAT

<parameter>: a numeric parameter that control the <mode>

- 0: Off
- 1: On

<cid>: (PDP Context Identifier) a numeric parameter (1-32) which specifies a particular PDP context definition. The parameter is local to the DTE-modem interface and is used in other PDP context-related commands.

Note: When the module is set in “CG” class, the modem always automatically makes a GPRS attachment after initialization, so AT+WGPRS? Always gives +WGPRS: 0,0 for the parameter 0.

Command Syntax: **AT+WGPRS**

AT+WGPRS=<mode>,<parameter>,[<cid>]	OK ERROR
AT+WGPRS=?	+WGPRS: <mode>, <parameter1>,[<cid>] [<CR><LF>+WGPRS: <mode>,<parameter>,[<cid>] [...]] OK
AT+WGPRS?	+WGPRS:<mode>(list of supported <parameter>),[(list of supported <cid>)]<CR><LF>+WGPRS:<mode>(list of supported <parameter>),[(list of supported <cid>)] [...]] OK

Example:

AT+WGPRS=2,1,3	AT+WGPRS?	+WGPRS: 2,0,3
OK	+WGPRS: 0,0	+WGPRS: 2,0,4
AT+WGPRS=?	+WGPRS: 1,0	+WGPRS: 3,1
+WGPRS: (0-3),(0-1),(0-4)	+WGPRS: 2,1,1	OK
OK	+WGPRS: 2,0,2	<CR><LF>

Full GPRS AT Command Examples

Activation of an IP PDP Context

Example 1

```
AT +CGDCONT=1, "IP", "internet"; +GCDCONT=2, "IP", "abc.com"  
OK  
ATD*99***1#  
CONNECT
```

Example 2

```
AT +CGCLASS="CG"  
OK  
+CGREG: 1  
AT +CGDCONT=1, "IP", "internet"  
OK  
AT +CGQREQ=1,1,4,5,2,14  
OK  
AT +CGQMIN=1,1,4,5,2,14  
OK  
AT +CGATT=1  
OK  
AT +CGACT=1,1  
OK  
//Remark about +CGDATA: the goal of this command is the same as ATD*99***  
AT +CGDATA=1  
CONNECT  
.....  
Data transfer  
.....  
+CGEV: NW DETACH
```

Network Request

```
AT+CGAUTO=0  
OK  
+CRING: GPRS "IP", "211.45.89.152"  
AT+CGANS=1  
CONNECT  
..... Data transfer
```

GPRS-Related Errors +CME ERROR

Errors related to a failure to perform an attach

Numeric Text

103	Illegal MS (#3)
106	Illegal ME (#6)
107	GPRS services not allowed (#7)
111	PLMN not allowed (#11)
112	Location area not allowed (#12)
113	Roaming not allowed in this location area (#13)

(Values in parentheses are GSM Technical Specification 04.08 cause codes.)

Errors related to a failure to Activate a Context

Numeric Text

132	service option not supported (#32)
133	requested service option not subscribed (#33)
134	service option temporarily out of order (#34)
149	PDP authentication failure
533	Missing or Unknown APN

(Values in parentheses are GSM Technical Specification 04.08 cause codes.)

Other GPRS errors

Numeric Text

150	invalid mobile class
148	unspecified GPRS error

Other values in the range 101 - 150 are reserved for use by GPRS
Also all other values below 256 are reserved

Specific GPRS Failure Cause for +CEER

Numeric Text

224	MS requested detach
225	NWK requested Detach
226	Unsuccessful attach cause NO SERVICE
227	Unsuccessful attach cause NO ACCESS
228	Unsuccessful attach cause GPRS SERVICE REFUSED
229	PDP deactivation requested by Nwk
230	PDP deactivation cause LLC link activation failed
231	PDP deactivation cause NWK reactivation with same TI
232	PDP deactivation cause GMM abort
233	PDP deactivation cause LLC or SNDSCP failure
234	PDP unsuccessful activation cause GMM error
235	PDP unsuccessful activation cause NWK reject
236	PDP unsuccessful activation cause NO NSAPI available
237	PDP unsuccessful activation cause SM refuse
238	PDP unsuccessful activation cause MMI ignore

CHAPTER 18 - OTHER AT COMMANDS

V.25ter Recommendation

The commands not listed in this document are not supported. For these commands, the product will then answer with "ERROR". All modulation control, error control and data compression commands are not recognized. An "ERROR" string will be returned.

GSM 07.05 Recommendation

All the 07.05 commands not described in this manual are not implemented. The product will answer "ERROR" to these commands.

GSM 07.07 Recommendation

All the 07.07 commands not described in this manual are not implemented. The product will answer "ERROR" to these commands.

APPENDIX A – RESULT CODES, FAILURE CAUSES, OTHER TABLES

Chapter Summary

The following tables are listed in Appendix A:

- ME error result code: +CME ERROR: <error>
- Message service failure result code: +CMS ERROR <er>
- Specific error results codes
- Failure Cause from GSM 05.08 recommendation (+CEER)
- Specific Failure Cause for +CEER
- GSM 04.11 Annex E-2: Mobile originating SM-transfer
- Unsolicited result codes
- Final result codes
- Intermediate result codes
- Parameter storage
- GSM sequences list
- Operator names
- Data Commands and Multiplexing

ME Error Result Code: +CME ERROR: <error>

<error>	Meaning	Resulting from the following commands
3	Operation not allowed	All GSM 07.07 commands (+CME ERROR: 3)
4	Operation not supported	All GSM 07.07 commands (+CME ERROR: 4)
5	PH-SIM PIN required (SIM lock)	All GSM 07.07 commands (+CME ERROR: 5)
10	SIM not inserted	All GSM 07.07 commands (+CME ERROR: 10)
11	SIM PIN required	All GSM 07.07 commands (+CME ERROR: 11)
12	SIM PUK required	All GSM 07.07 commands (+CME ERROR: 12)
13	SIM failure	All GSM 07.07 commands (+CME ERROR: 13)
16	Incorrect password	+CACM, +CAMP, +CPUC, +CLCK, +CPWD, +CPIN, +CPIN2 (+CME ERROR: 16)
17	SIM PIN2 required	+CPBW (FDN), +CLCK (FDN),
18	SIM PUK2 required	+CACM, +CAMP, +CPUC, +CPBW (FDN), +CPIN, +CPIN2, +CLCK (FDN), +CPWD
20	Memory full	+CPBW
21	Invalid index	+CPBR, +CPBW, ATD>[mem]index, +WMGO
22	Not found	+CPBF, +CPBP, +CPBN, +CGSN, +WOPN, ATD>[mem]"name"
24	Text string too long	+CPBW, +CPIN, +CPIN2, +CLCK, +CPWD
26	Dial string too long	+CPBW, ATD, +CCFC
27	Invalid characters in dial string	+CPBW
30	No network service	+VTS, +COPS=?, +CLCK, +CCFC, +CCWA, +CUSD
32	Network not allowed – emergency calls only	+COPS
40	Network personal PIN required (Network lock)	All GSM 07.07 commands (+CME ERROR: 40)
103	Illegal MS (#3)	+CGATT
106	Illegal ME (#6)	+CGATT
107	GPRS services not allowed (#7)	+CGATT
111	PLMN not allowed (#11)	+CGATT
112	Location area not allowed (#12)	+CGATT
113	Roaming not allowed in this area (#13)	+CGATT
132	service option not supported (#32)	+CGACT +CGDATA ATD*99
133	requested service option not subscribed (#33)	+CGACT +CGDATA ATD*99
134	service option temporarily out of order (#34)	+CGACT +CGDATA ATD*99
148	unspecified GPRS error	All GPRS commands
149	PDP authentication failure	+CGACT +CGDATA ATD*99
150	invalid mobile class	+CGCLASS +CGATT

Message Service Failure Result Code +CMS ERROR: <er>

<er> is defined as below:

<er>	Meaning	Resulting from the following commands
1 to 127	Error cause values from the GSM recommendation 04.11 Annex E-2	+CMGS, +CMSS
301	SMS service of ME reserved	+CSMS (with +CMS: ERROR 301)
302	Operation not allowed	All SMS commands (+CMSS, +CMGL, +CPMS, +CSMP...
303	Operation not supported	All SMS commands
304	Invalid PDU mode parameter	+CMGS, +CMGW
305	Invalid text mode parameter	+CMGS, +CMGW, +CMSS
310	SIM not inserted	All SMS commands
311	SIM PIN required	All SMS commands
312	PH-SIM PIN required	All SMS commands
313	SIM failure	All SMS commands
316	SIM PUK required	All SMS commands
317	SIM PIN2 required	All SMS commands
318	SIM PUK2 required	All SMS commands
321	Invalid memory index	+CMGR, +CMSS, +CMGD
322	SIM memory full	+CMGW
330	SC address unknown	+CSCA?, +CMSS, +CMGS
340	no +CNMA acknowledgement expected	+CNMA

Specific Error Result Codes

<error>	Meaning	Resulting from the following commands
500	unknown error.	All commands
512	MM establishment failure (for SMS).	+CMGS, +CMSS (+CMS ERROR: 512)
513	Lower layer failure (for SMS)	+CMGS, +CMSS (+CMS ERROR: 513)
514	CP error (for SMS).	+CMGS, +CMSS (+CMS ERROR: 514)
515	Please wait, init or command processing in progress.	All commands ("+CME ERROR: 515" or "+CMS ERROR: 515")
517	SIM ToolKit facility not supported.	+STGI
518	SIM ToolKit indication not received.	+STGI
519	Reset the product to activate or change a new echo cancellation algo.	+ECHO, +VIP
520	Automatic abort about get plmn list for an incoming call.	+COPS=?
526	PIN deactivation forbidden with this SIM card.	+CLCK
527	Please wait, RR or MM is busy. Retry your selection later.	+COPS
528	Location update failure. Emergency calls only.	+COPS
529	PLMN selection failure. Emergency calls only.	+COPS
531	SMS not sent: the <da> is not in FDN phonebook, and FDN lock is enabled. (for SMS)	+CMGS, +CMSS (+CMS ERROR: 531)
532	the embedded application is activated so the objects flash are not erased	+WOPEN
533	Missing or Unknown APN	ATD*99 +GACT +CGDATA

Failure Cause from GSM 04.08 Recommendation (+CEER)

Cause value	Diagnostic
1	Unassigned (unallocated) number
3	No route to destination
6	Channel unacceptable
8	Operator determined barring
16	Normal call clearing
17	User busy
18	No user responding
19	User alerting, no answer
21	Call rejected
22	Number changed
26	Non selected user clearing
27	Destination out of order
28	Invalid number format (incomplete number)
29	Facility rejected
30	Response to STATUS ENQUIRY
31	Normal, unspecified
34	No circuit/channel available
38	Network out of order
41	Temporary failure
42	Switching equipment congestion
43	Access information discarded
44	Requested circuit/channel not available
47	Resources unavailable, unspecified
49	Quality of service unavailable
50	Requested facility not subscribed
55	Incoming calls barred with in the CUG
57	Bearer capability not authorized
58	Bearer capability not presently available
63	Service or option not available, unspecified
65	Bearer service not implemented
68	ACM equal to or greater than ACMmax
69	Requested facility not implemented
70	Only restricted digital information bearer capability is available
79	Service or option not implemented, unspecified
81	Invalid transaction identifier value
87	User not member of CUG
88	Incompatible destination
91	Invalid transit network selection
95	Semantically incorrect message
96	Invalid mandatory information
97	Message type non-existent or not implemented
98	Message type not compatible with protocol state
99	Information element non-existent or not implemented
100	Conditional IE error
101	Message not compatible with protocol state
102	Recovery on timer expiry
111	Protocol error, unspecified
127	Interworking, unspecified
224	MS requested detach
225	PDP unsuccessful activation cause MMI ignore
226	NWK requested Detach
227	Unsuccessful attach cause NO SERVICE
228	Unsuccessful attach cause NO ACCESS
229	Unsuccessful attach cause GPRS SERVICE REFUSED
230	PDP deactivation requested by Nwk
231	PDP deactivation cause LLC link activation failed
232	PDP deactivation cause NWK reactivation with same TI
233	PDP deactivation cause GMM abort
234	PDP deactivation cause LLC or SNDSCP failure
235	PDP unsuccessful activation cause GMM error
236	PDP unsuccessful activation cause NWK reject
237	PDP unsuccessful activation cause NO NSAPI available
238	PDP unsuccessful activation cause SM refuse

All other values in the range 0 to 31 shall be treated as cause 3. All other values in the range 32 to 47 shall be treated as cause 47.

All other values in the range 48 to 63 shall be treated as cause 63. All other values in the range 64 to 79 shall be treated as cause 79.

All other values in the range 80 to 95 shall be treated as cause 95. All other values in the range 96 to 111 shall be treated as cause 111.

All other values in the range 112 to 127 shall be treated as cause 127.

Specific Failure Cause for +CEER

Cause value	Diagnostic
240	FDN is active and number is not in FDN
241	Call operation not allowed
252	Call barring on outgoing calls
253	Call barring on incoming calls
254	Call impossible
255	Lower layer failure

GSM 04.11 Annex E-2: Mobile Originating SM-Transfer

These error causes could appear for **SMS commands** (+CMGS, +CMSS, +CMGD...)

Cause No. 1: "Unassigned (unallocated) number"

This cause indicates that the destination requested by the Mobile Station cannot be reached because, although the number is in a valid format, it is not currently assigned (allocated).

Cause No. 8: "Operator determined barring"

This cause indicates that the MS has tried to send a mobile originating short message when the MS's network operator or service provider has forbidden such transactions.

Cause No. 10: "Call barred"

This cause indicates that the outgoing call barred service applies to the short message service for the called destination.

Cause No. 21: "Short message transfer rejected"

This cause indicates that the equipment sending this cause does not wish to accept this short message, although it could have accepted the short message since the equipment sending this cause is neither busy nor incompatible.

Cause No. 27: "Destination out of service"

This cause indicates that the destination indicated by the Mobile Station cannot be reached because the interface to the destination is not functioning correctly. The term "not functioning correctly" indicates that a signaling message was unable to be delivered to the remote user; e.g., a physical layer or data link layer failure at the remote user, user equipment off-line, etc.

Cause No. 28: "Unidentified subscriber"

This cause indicates that the subscriber is not registered in the PLMN (e.g.. IMSI not known)

Cause No. 29: "Facility rejected"

This cause indicates that the facility requested by the Mobile Station is not supported by the PLMN.

Cause No. 30: "Unknown subscriber"

This cause indicates that the subscriber is not registered in the HLR (e.g.. IMSI or directory number is not allocated to a subscriber).

Cause No. 38: "Network out of order"

This cause indicates that the network is not functioning correctly and that the condition is likely to last a relatively long period of time; e.g., immediately reattempting the short message transfer is not likely to be successful.

Cause No. 41: "Temporary failure"

This cause indicates that the network is not functioning correctly and that the condition is not likely to last a long period of time; e.g., the Mobile Station may wish to try another short message transfer attempt almost immediately.

Cause No. 42: "Congestion"

This cause indicates that the short message service cannot be serviced because of high traffic.

Cause No. 47: "Resources unavailable, unspecified"

This cause is used to report a resource unavailable event only when no other cause applies.

Cause No. 69: "Requested facility not implemented"

This cause indicates that the network is unable to provide the requested short message service.

Cause No. 81: "Invalid short message transfer reference value"

This cause indicates that the equipment sending this cause has received a message with a short message reference which is not currently in use on the MS-network interface.

Cause No. 95: "Invalid message, unspecified"

This cause is used to report an invalid message event only when no other cause in the invalid message class applies.

Cause No. 96: "Invalid mandatory information"

This cause indicates that the equipment sending this cause has received a message where a mandatory information element is missing and/or has a content error (the two cases are undistinguishable).

Cause No. 97: "Message type non-existent or not implemented"

This cause indicates that the equipment sending this cause has received a message with a message type it does not recognize either because this is a message not defined or defined but not implemented by the equipment sending this cause.

Cause No. 98: "Message not compatible with short message protocol state"

This cause indicates that the equipment sending this cause has received a message such that the procedures do not indicate that this is a permissible message to receive while in the short message transfer state.

Cause No. 99: "Information element non-existent or not implemented"

This cause indicates that the equipment sending this cause has received a message which includes unrecognized information elements because the information element identifier is not defined or it is defined but not implemented by the equipment sending the cause. However, the information element is not required to be present in the message so that the equipment sends the cause to process the message.

Cause No. 111: "Protocol error, unspecified"

This cause is used to report a protocol error event only when no other cause applies.

Cause No. 127: "Interworking, unspecified"

This cause indicates that there has been interworking with a network which does not provide causes for actions it takes; thus, the precise cause for a message which is being sent cannot be determined. All values other than specified should be treated as error Cause No 41.

Unsolicited Result Codes

Verbose Result Code	Numeric (V0 set)	Description
+CALA: <time string>,<index>	As verbose	Alarm notification
+CBM: <length><pdu> (PDU) or +CBM:<sn>,<mid>,<dcs>,<page>,<pages>... (Text mode)	As verbose	Cell Broadcast Message directly displayed
+CBMI: "BM",<index>	As verbose	Cell Broadcast Message stored in mem at location <index>
+CCCM: <ccm>	As verbose	Current Call Meter value
+CCED: <values>	As verbose (specific)	Cell Environment Description indication
+CCWA:<number>,<type>, <class> [,<alpha>]	As verbose	Call Waiting number
+CDS: <fo>, <mr>... (text mode) or +CDS: <length>,... (PDU)	As verbose	SMS status report after sending a SMS
+CDSI: <mem>,<index>	As verbose	Incoming SMS Status Report after sending a SMS, stored in <mem> ("SR") at location <index>
+CKEV: <keynb>	As verbose	Key press or release
+CLIP: <number>, <type> [,,<alpha>]	As verbose	Incoming Call Presentation
+CMT: <oa>... (text mode) or +CMT: [<alpha>]... (PDU)	As verbose	Incoming message directly displayed
+CMTI: <mem>,<index>	As verbose	Incoming message stored in <mem> ("SM") at location <index>
+CREG: <stat> [,<lac>,<ci>]	As verbose	Network registration indication
+CRING: <type>	As verbose	Incoming call type (VOICE, FAX ...)
+CSQ: <RxLev>,99	As verbose	Automatic RxLev indication with AT+CCED=1,8 command
+CSSU: <code2>[<number>,<type>]	As verbose	Supplementary service notification during a call
+STIN: <ind>	As verbose (specific)	SIM ToolKit Indication
+WIND: <IndicationNb> [,<CallId>]	As verbose (specific)	Specific unsolicited indication (SIM Insert/Remove, End of init, Reset, Alerting, Call creation/release)
+WVMI: <LinId>,<Status>	As verbose (specific)	Voice Mail Indicator notification (cf. +CPHS command)
+WDCI: <LinId>,<Status>	As Verbose (specific)	Diverted call indicator
RING	2	Incoming call signal from network
+CIEV	As Verbose (specific)	Indicator event reporting

Final Result Codes

Verbose Result Code	Numeric (V0 set)	Description
+CME ERROR: <err>	As verbose	Error from GSM 07.05 commands
+CMS ERROR: <err>	As verbose	Error from SMS commands (07.07)
BUSY	7	Busy signal detected
ERROR	4	Command not accepted
NO ANSWER	8	Connection completion timeout
NO CARRIER	3	Connection terminated
OK	0	Acknowledges correct execution of a command line
RING	2	Incoming call signal from network

Intermediate Result Codes

Verbose Result Code	Numeric (V0 set)	Description
+COLP:<number>,<type>	as verbose	Outgoing Call Presentation
+CR: <type>	as verbose	Outgoing Call report control
+ILRR: <rate>	as verbose	Local TA-TE data rate
CONNECT 300	10	Data connection at 300 bauds
CONNECT 1200	11	Data connection at 1200 bauds
CONNECT 1200/75	12	Data connection at 1200/75 bauds
CONNECT 2400	13	Data connection at 2400 bauds
CONNECT 4800	14	Data connection at 4800 bauds
CONNECT 9600	15	Data connection at 9600 bauds
CONNECT 14400	16	Data connection at 14400 bauds
+CSSI: <code1>[,<index>]	As verbose	Supplementary service notification during a call setup

Parameter Storage Mode

Parameter Storage Mode					
Command	AT&W (E2P)	Command (E2P)	AT+CSAS (SIM, E2P)	AT&F (SIM, E2P)	Default values
General commands					
+CMEE	X			X	0
+CSCS	X			X	"PCCP437"
+WPCS	X			X	"TRANSPARENT"
Call Control commands					
%D		X		X	0
ATSO	X			X	0 (no auto-answer)
+CICB	X			X	2 (speech)
+CSNS	X			X	0 (voice)
+ECHO		X		X	,1,0,3,10,7 (Algo ID 1) ,3,30,8000,256 (Algo ID 3)
+SIDET	X			X	1,1
+SPEAKER	X			X	0 (Spk 1 & Mic 1)
+VGR	X			X	64 (speaker 1) 32 (speaker 2)
+VGT	X			X	64 (mic 1 & ctrl 1) 0 (others)
Network Service commands					
+COPS	X	X		X	0,2
+CREG	X			X	0
Phonebook commands					
+WAIP	X			X	0
+CSVM		X		X	0
SMS commands					
+CMGF	X			X	1 (text)
+CNMI			X	X	0,1,0,0,0
+CSCA			X		SIM dependant (phase 2)
+CSDH	X			X	0
+CSMP			X	X	1,167,0,0
+CSMS		X			0
+WUSS		X		X	0
Supplementary Services commands					
+CCUG		X			0,0,0
+CCWA	X			X	0
+CLIP	X			X	0
+COLP	X			X	0
+CSSN	X			X	0,0
+CUSD		X		X	0
Data commands					
%C	X			X	0
\N	X			X	0
+CBST	X			X	0,0,1
+CR	X			X	0
+CRC	X			X	0
+CRLP	X			X	61,61,48,6,1
+DOPT	X			X	1,1
+DS	X			X	3,0,4096,20
+DR	X			X	0
+ILRR	X			X	0
Fax Class 2 commands					
+FBOR	X			X	0
+FCQ	X			X	0
+FCR	X			X	1
+FDCC,+FDIS	X			X	0,5,0,0,2,0,0,0,0
+FPHCTO	X			X	30
V24 – V25 commands					
&C	X				1
&D	X				1
&S	X				1
E	X				1
Q	X			X	0
V	X			X	1
+ICF	X				3,4
+IFC	X				2,2

Parameter Storage Mode					
Command	AT&W (E2P)	Command (E2P)	AT+CSAS (SIM, E2P)	AT&F (SIM, E2P)	Default values
+IPR	X				9600
+WMUX	X			X	0
Specific commands					
+ADC		X		X	0
+CMER	X			X	0
+CPHS		X		X	,0
+WCDM		X		X	0,0
+WDR		X			2
+WIND		X		X	0
+WIOM		X			255,0
+WRIM		X		X	0
+WSVG		X		X	0
+WVR		X			5
SIM ToolKit commands					
+STSF		X			0,"160060C01F",3,0
GPRS commands					
+GCAUTO	X			X	3
+GCCLASS		X			"B"
+GCDCONT		X			
+GCEREP	X			X	0
+GCREG	X			X	0
+GCSMS		X			1
+WGPRS		X			0,1 1,0 3,0

GSM Sequences List

In accordance with **GSM Technical Specification 02.30**, the product supports the following GSM sequences, which can be used through the ATD and the +CKPD commands.

Security

**04*OLDPIN*NEWPIN*NEWPIN#	Change PIN code
**042*OLDPIN2*NEWPIN2*NEWPIN2#	Change PIN2 code
**05*PUK*NEWPIN*NEWPIN#	Unlock PIN code
**052*PUK2*NEWPIN2*NEWPIN2#	Unlock PIN2 code
*#06#	Show the IMEI number

Call Forwarding

*SC# or *SC**bs#	Activate
**SC*PhoneNumber# or **SC*PhoneNumber*BS# or **SC*PhoneNumber*[BS]*T# or *SC*PhoneNumber# or *SC*PhoneNumber*BS# or *SC*PhoneNumber*[BS]*T#	Register and activate
*#SC# or *#SC**BS#	Check status
#SC# or #SC**BS#	Deactivate
##SC# or ##SC**BS#	Unregistered and deactivate

The Service codes (SC) are:

002	all call forwarding
004	all conditional call forwarding
21	call forwarding unconditional
61	call forwarding on no answer
62	call forwarding on not reachable
67	call busy

The Network service codes (BS) are:

No code	All tele and bearer services
10	All teleservices
11	Telephony
12	All data teleservices
13	Fax services
16	Short Message Services
17	Voice Group Call Service
18	Voice Broadcast Service
19	All teleservices except SMS
20	All bearer services
21	All asynchronous services
22	All synchronous services
24	All data circuit synchronous
25	All data circuit asynchronous
26	All dedicated packet access
27	All dedicated PAD access

The no reply condition timer (T) is only used for SC = 002, 004 or 61.

Call Barring

*SC*Password# or *SC*Password*BS#	Activate
*#SC# or *#SC**BS#	Check status
#SC*Password# or #SC*Password*BS#	Deactivate
**03*330*OLDPWD*NEWPWD*NEWPWD#	Change password for call barring
03OLDPWD*NEWPWD*NEWPWD#	
*03*330*OLDPWD*NEWPWD*NEWPWD#	
*03**OLDPWD*NEWPWD*NEWPWD#	

The Service codes (SC) are:

33	call barring of outgoing call
330	all barring service (only for deactivation)
331	call barring of outgoing international call
332	call barring of outgoing international calls except to HPLMN
333	all outgoing barring service (only for deactivation)
35	call barring of incoming calls
351	call barring of incoming calls if roaming
353	all incoming barring service (only for deactivation)

Note: Network service codes (BS) are the same the call forwarding sequences.

Call Waiting

*43#	Activate
*#43#	Check status
#43#	Deactivate

Number Presentation

*#30#	CLIP check status
*#31#	CLIR check status
*31#PhoneNumber	Invoke CLIR for a voice call
#31#PhoneNumber	Suppress CLIR for a voice call
*#76#	COLP check status

Operator Names

Country Initials	MCC	MNC	Preferred Presentation of Country Initials and Mobile Network Name	Abbreviated Mobile Network Name
A	311	140	Sprocket	Sprocket
A	332	011	Blue Sky	Blue Sky
A	232	01	A1	A1
A	232	003	T-Mobile A	TMO A
A	232	005	A One	one
A	232	007	A tele.ring	telering
A	232	010	3 AT	3 AT
ABW	363	001	SETAR GSM	SETARGSM
AF	412	001	AF AWCC	AWCC
AGO	631	002	UNITEL	UNITEL
AL	276	001	AMC-AL	A M C
AL	276	002	vodafone AL	voda AL
ALG	603	001	ALGERIAN MOBILE NETWORK	AMN
ALG	603	002	Djezzy	Djezzy
AN	344	030	APUA PCS ANTIGUA	APUA-PCS
AND	213	003	STA-MOBILAND	M-AND
ANT	362	051	Telcell GSM	Telcell
ANT	362	069	ANT CURACAO TELECOM	CT GSM
ANT	362	091	UTS Wireless Curacao N.V.	UTS
AR	722	034	PERSONAL	AR TP
ARG	722	007	UNIFON	UNIFON
ARG	722	035	PORT-HABLE	P-HABLE
AS	544	011	Blue Sky	Blue Sky
AUS	505	001	Telstra Mobile	Telstra
AUS	505	002	YES OPTUS AUS	Optus
AUS	505	003	VODAFONE AUS	VFONE
AUS	505	006	H3GA	H3GA
AZE	400	001	AZE-AZERCELL GSM	ACELL
AZE	400	002	BAKCELL GSM 2000	BKCELL
B	206	010	B mobistar	mobi*
BA	218	003	BA-ERONET	ERONET
BA	218	005	MOBI'S	MOBI'S
BA	218	090	BIH GSMBIH	GSMBIH
BD	470	003	DB SHEBAWORLD	SHEBA
BDA	350	001	TELECOM BDA	TELE BDA
BE	206	020	BASE	BASE
BEL	206	001	BEL PROXIMUS	PROXI
BEN	616	002	TELECEL BENIN	TLCL-BEN
BEN	616	003	BJ BENINCELL	BENCELL
BEN	616	004	BELL BENIN COMMUNICATION	BB COM
BF	002	002	BF CELTEL	CELTEL
BG	284	001	M-TEL GSM BG	M-TEL
BG	284	005	BG GLOBUL	GLOBUL
BGD	470	001	BGD-GP	GP
BGD	470	002	BGD AKTEL	AKTEL
BHR	426	001	BATELCO	BATELCO
BI	642	001	Spacetel BI	SPACETEL
BL	702	067	BTL	BTL
BMU	350	002	BTC MOBILITY LTD.	MOBILITY
BO	736	002	MOVIL-E	BOMOV
BOL	736	001	NUEVATEL	VIVA
BRA	724	001	TIM BRASIL	TIM
BRA	724	002	TIM BRASIL	TIM
BRA	724	003	TIM BRASIL	TIM
BRA	724	004	TIM BRASIL	TIM
BRA	724	031	Oi	Oi
BRU	528	11	BRU-DSTCom	DSTCom
BTN	402	017	BT B-MOBILE	B-MOBILE
BUR	642	002	BUSAFA	SAFARIS
BW	652	001	BW MASCOM	MASCOM
BW	652	002	BW VISTA	VISTA
BY	257	001	BY VELCOM	VELCOM
CAM	624	002	Orange CAM	Orange

Country Initials	MCC	MNC	Preferred Presentation of Country Initials and Mobile Network Name	Abbreviated Mobile Network Name
CAN	302	370	Microtell	MCELL
CAN	302	720	Rogers AT&T Wireless	ROGERS
CD	629	001	CELTEL CD	CDLTEL
CD	630	089	CD OASIS	OASIS
CH	228	001	SWISS GSM	SWISS
CH	228	002	Sunrise	Sunrise
CH	228	003	Orange CH	Orange
CHN	460	000	CHINA MOBILE	CMCC
CHN	460	001	CHN-CUGSM	CU-GSM
CI	612	001	CI CORA	CORA
CI	612	003	Orange CI	Orange
CI	612	005	TELECEL-CI	TELCEL
CL	730	001	ENTEL PCS	ENTEL PCS
CL	730	010	ENTEL PCS	ENTEL PCS
CMR	624	001	MTN CAM	62401
COG	629	010	COG LIBERTIS	LIBERTIS
CPV	625	001	CPV MOVEL	CMOVEL
CRI	712	001	I.C.E.	I.C.E.
CU	368	001	CU/C_COM	C_COM
CY	280	001	CY CYTAGSM	CY-GSM
CZ	230	001	T-Mobile CZ	TMO CZ
CZ	230	002	EUROTEL – CZ	ET - CZ
CZ	230	003	OSKAR	OSKAR
D	262	001	T-MOBILE D	TMO D
D	262	002	Vodafone D2	Voda D2
D	262	003	E-Plus	E-Plus
D	262	007	o2 - de	o2 - de
D	262	013	MobilCom	MobilCom
D	161	014	Quam	Quam
DK	238	001	TDC-MOBIL	DK TDC
DK	238	002	DK SONOFON	SONO
DK	238	020	TELIA DK	TELIA
DK	238	030	Orange	Orange
DO	370	001	ORANGE	ORANGE
DRC	630	001	CELLCO GSM	CELLCO
E	214	001	Vodafone ES	Voda ES
E	214	002	MOVISTAR	MSTAR
E	214	003	E AMENA	AMENA
E	214	004	XFERA	XFERA
E	214	007	MOVISTAR	MSTAR
EE	248	00	EE EMT GSM	EMT
EE	248	002	EE RLE	RLE
EE	248	003	TELE2	TELE2
EGY	602	001	EGY MobiNiL	MobiNiL
EGY	602	002	Vodafone EG	Voda EG
ESV	706	001	ESV PERSONAL	PERSONAL
ESV	706	010	ESV PERSONAL	PERSONAL
ETH	636	001	ETH-MTN	ET-MTN
F	208	001	Orange F	Orange
F	208	010	F SFR	SFR
F	208	020	F – BOUYGUES TELECOM	BYTEL
F	340	001	F-Orange	Orange
F	340	020	BOUYGTEL-C	BOUYG-C
F	340	020	F-VINI	VINI
F	647	010	SFR REUNION	SFR RU
FI	244	003	FI TELIA	TELIA
FI	244	005	FI RADIOLINJA	RL
FI	244	009	FI FINNET	FINNET
FI	244	014	FI AMT	FI AMT
FI	244	091	FI SONERA	SONERA
FIN	244	012	FI 2G	2G
FJ	542	001	FJ VODAFONE	VODAFONE
FO	288	001	FO FT-GSM	FT-GSM
FO	288	002	KALL	KALL
FSM	550	001	FSM Telecom	FSMTC
GA	628	003	CELTEL GA	CELTEL
GAB	628	001	628 01/LIBERTIS	LIBERTIS

Country Initials	MCC	MNC	Preferred Presentation of Country Initials and Mobile Network Name	Abbreviated Mobile Network Name
GAB	628	002	GAB TELCEL	TELCEL
GEO	282	001	GEO-GEOCELL	GCELL
GEO	282	002	MAGTI-GSM-GEO	MAGTI
GH	620	001	GH SPACEFON	SPACE
GH	620	002	GH ONEtouch	ONEtouch
GH	620	003	GH-MOBITEL	MOBITEL
GIB	266	001	GIBTEL GSM	GIBTEL
GL	290	001	TELE Greenland	TELE GRL
GM	607	002	AFRICLEE	AFRICELL
GMB	607	001	GAMCEL	GAMCEL
GN	611	002	GN LAGUI	LAGUI
GNQ	627	001	GNQ01	GETESA
GR	202	001	GR COSMOTE	C-OTE
GR	202	005	VODAFONE GR	VODA GR
GR	202	009	GR Q-TELECOM	Q-TELECOM
GR	202	010	GR TELESTET	TLSTET
HK	454	000	CSL	CSL
HK	454	004	HK Orange	ORANGE
HK	454	006	HK SMARTONE	HKSMC
HK	454	010	HK NEW WORLD	NWPCS
HK	454	012	HK PEOPLES	PEOPLES
HK	454	016	HK SUNDAY	SUNDAY
HR	219	001	HR-CRONET	CRON
HR	219	010	HR-VIP	VIP
HU	216	001	H PANNON GSM	PANNON
HU	216	030	WESTEL	WESTEL
HU	216	070	VODAFONE HU	VODAFONE
I	222	001	I TIM	TIM
I	222	010	VODAFONE IT	VODA IT
I	222	088	I WIND	I WIND
IL	425	001	IL ORANGE	ORANGE
IL	425	002	IL CELLCOM	CELLCOM
INA	404	002	AIRTEL	AIRTEL
INA	404	003	AIRTEL	AIRTEL
INA	404	005	INA CELFORCE	CELFORCE
INA	404	010	AIRTEL	AIRTEL
INA	404	011	HUTCH	HUTCH
INA	404	012	INA – ESCOTEL	ESCOTL
INA	404	014	INA SPICE	SPICE
INA	404	020	INA MaxTouch	MAXTCH
INA	404	021	BPL MOBILE	BPL MOBILE
INA	404	022	IDEA	IDEA
INA	404	024	IDEA	IDEA
INA	404	027	BPL MOBILE	BPL MOBILE
INA	404	030	INA HUTCH	HUTCH
INA	404	031	AIRTEL	AIRTEL
INA	404	040	INA INTEL	AIRTEL
INA	404	041	INA RPG	RPG
INA	404	042	INA AIRCEL	AIRCEL
INA	404	043	BPL MOBILE	BPL MOB
INA	404	044	INA SPICE	SPICE
INA	404	045	AIRTEL	AIRTEL
INA	404	046	BPL MOBILE	BPL MOB
INA	404	049	AIRTEL	AIRTEL
INA	404	078	IDEA	IDEA
INA	404	090	AIRTEL	AIRTEL
INA	404	092	AIRTEL	AIRTEL
INA	404	093	AIRTEL	AIRTEL
INA	404	094	AIRTEL	AIRTEL
INA	404	095	AIRTEL	AIRTEL
INA	404	096	AIRTEL	AIRTEL
INA	404	097	AIRTEL	AIRTEL
INA	404	098	AIRTEL	AIRTEL
IND	404	001	ESSAR	ESSAR
IND	404	013	HUTCH	HUTCH
IND	404	015	ESSAR	ESSAR
IND	404	034	BSNL MOBILE	CellOne

Country Initials	MCC	MNC	Preferred Presentation of Country Initials and Mobile Network Name	Abbreviated Mobile Network Name
IND	404	038	BSNL MOBILE	CellOne
IND	404	051	BSNL MOBILE	CellOne
IND	404	053	BSNL MOBILE	CellOne
IND	404	054	BSNL MOBILE	CellOne
IND	404	055	BSNL MOBILE	CellOne
IND	404	057	BSNL MOBILE	CellOne
IND	404	058	BSNL MOBILE	CellOne
IND	404	059	BSNL MOBILE	CellOne
IND	404	060	ESSAR	ESSAR
IND	404	062	BSNL MOBILE	CellOne
IND	404	064	BSNL MOBILE	CellOne
IND	404	066	BSNL MOBILE	CellOne
IND	404	068	IN-DOLPHIN	DOLPHIN
IND	404	069	IN-DOLPHIN	DOLPHIN
IND	404	071	BSNL MOBILE	CellOne
IND	404	072	BSNL MOBILE	CellOne
IND	404	073	BSNL MOBILE	CellOne
IND	404	074	BSNL MOBILE	CellOne
IND	404	075	BSNL MOBILE	CellOne
IND	404	076	BSNL MOBILE	CellOne
IND	404	077	BSNL MOBILE	CellOne
IND	404	079	BSNL MOBILE	CellOne
IND	404	080	BSNL MOBILE	CellOne
IND	404	081	BSNL MOBILE	CellOne
IND	404	086	HUTCH	HUTCH
IND	510	000	ACeS	ACeS
IND	510	001	IND SATELINDOCEL	SAT-C
IND	510	008	LIPPO TEL	LIPPOTEL
IND	510	010	IND TELKOMSEL	T-SEL
IND	510	011	IND - EXCELCOM	proXL
IND	510	021	IND IM3	IM-3
IR	432	011	IR-TCI	432 11
IR	432	014	IR-KISH	KIFZO
IRL	272	001	IRL VODAFONE	IRL VODA
IRL	272	002	02 - IRL	02 - IRL
IRL	272	003	IRL – METEOR	METEOR
IS	274	001	IS SIMINN	SIMINN
IS	274	002	IS TAL	TAL
IS	274	003	IS islandssimi hf	Islandss
IS	274	004	Viking	Viking
IT	222	098	IT BLU	BLU
ITA	222	099	3 ITA	3 ITA
JAM	338	020	Cable & Wireless JM	C&W
JM	338	005	JM DIGICEL	DIGICEL
JOR	416	001	Fastlink	FSTLNK
JOR	416	077	JO MobCom	MobCom
JP	440	010	JP DoCoMo	DoCoMo
KE	639	002	Safaricom	SAF-COM
KE	639	003	KE-KENCELL	KENCELL
KGZ	437	001	BITEL KGZ	BITEL
KHM	456	001	MOBITEL-KHM	MT-KHM
KHM	456	002	KHM>Hello GSM	KHM-SM
KHM	456	018	CAMBODIA SHINAWATRA	CAMSHIN
KSA	420	001	ALJAWAL	KSA
KT	419	002	KT MTCNet	MTC
KT	419	003	KT WATANIYA	WATANIYA
KZ	401	001	KZ K-MOBILE	K-MOBILE
KZ	401	002	KZ KCELL	KCELL
L	270	001	L LUXGSM	LUXGSM
L	270	077	L TANGO	TANGO
LAO	457	001	LAO GSM	LAO GSM
LAO	457	002	ETL MOBILE NETWORK	ETLMNW
LAO	457	008	TANGO LAO	TANGO
LBR	618	001	LBR Lonestar Cell	Lonestar
LI	295	001	TELECOM FL	FLGSM
LI	295	002	MONTEL	MONTEL
LIE	295	005	FL1	FL1

Country Initials	MCC	MNC	Preferred Presentation of Country Initials and Mobile Network Name	Abbreviated Mobile Network Name
LIE	295	077	LI TANGO	TANGO
LSO	651	001	VCL COMMS	VCLCOM
LSO	651	002	LS-ECONET-EZI-CEL	EZI-CEL
LT	246	002	LT BITE GSM	BITE
LTU	246	001	OMNITEL LT	OMT
LTU	24	003	TELE2	TELE2
LV	247	001	LV LMT GSM	LMT GSM
LV	247	002	LV TELE2	TELE2
MAC	455	000	MACAU SMC	SmarTone
MAC	455	001	MAC-CTMGSM	CTMGSM
MAC	455	003	Hutchinson MAC	HT MACAU
MD	259	001	MD VOXTEL	VOXTEL
MD	259	002	MD MOLDCELL	MDCELL
MG	646	001	MG MADACOM	MADACOM
MG	646	002	MG ANTARIS	ANTARIS
MKD	294	001	MKD MOBIMAK	MOBI-M
MKD	294	002	MKD, MTS A.D.	MTS AD
ML	610	001	MALITEL ML	MALITEL
ML	610	002	IKATEL ML	IKATEL
MM	414	001	MM 900	MPTGSM
MN	428	099	MN MOBICOM	MOBICOM
MOR	604	000	MOR MEDITEL	MEDITEL
MOR	604	001	MOR IAM	IAM
MOZ	643	001	MOZ-mCel	mCel
MR	609	001	MR MATTEL	MATTEL
MRU	617	001	CELLPLUS-MRU	CELL +
MRU	617	010	EMTEL-MRU	EMTEL
MT	278	001	VODAFONE MT	VODA MT
MT	278	021	GO MOBILE	GOMOBILE
MV	472	001	MV DHIMOBILE	D-MOBILE
MW	650	001	MW CP 900	CP 900
MW	650	100	CELTEL MW	CELTEL
MX	334	020	TELCEL GSM	TELCEL
MY	502	012	MY maxis mobile	maxis
MY	502	013	MY TMTOUCH	TMTOUCH
MY	502	016	DiGi	DiGi
MY	502	017	MY TIMECel	TIMECel
MY	502	019	MY CELCOM	CELCOM
N	242	001	N Telenor	TELENOR
N	242	002	N NetCom GSM	N COM
NA	649	001	MTC NAMIBIA	MTCNAM
NCL	546	001	NCL MOBILIS	MOBNCL
NE	614	002	NE CELTEL	CELTEL
NG	621	020	ECONET NG	ECONET
NG	621	030	MTN - NG	MTN - NG
NG	621	040	NG NITEL	NG NITEL
NL	204	004	VODAFONE NL	VODA NL
NL	204	008	NL KPN	NL KPN
NL	204	012	Q2 - NL	Q2 - NL
NL	204	016	Ben NL	Ben NL
NL	204	020	ORANGE NL	ORANGE
NZ	530	001	VODAFONE NZ	VODA
OMN	422	002	OMAN MOBILE	OMAN
P	268	001	VODAFONE P	VODA
P	268	003	P OPTIMUS	OPTIM
P	268	006	P TMN	TMN
PE	716	010	TIM PERU	TIM
PGY	744	001	HOLA PARAGUAY	VOX
PH	515	001	ISLACOM	ISLACOM
PH	515	002	GLOBE TELECOM-PH	GLOBE
PH	515	003	SMART	SMART
PH	515	005	DIGITEL	DIGITEL
PH	515	011	ACeS	ACeS
PH	515	020	ACeS	ACeS
PK	410	003	PK-UFONE	UFONE
PL	260	001	Plus GSM	PLUS
PL	260	002	ERA	ERA

Country Initials	MCC	MNC	Preferred Presentation of Country Initials and Mobile Network Name	Abbreviated Mobile Network Name
PL	260	003	PL IDEA	IDEA
PRK	467	193	KP SUN	SUNNET
PS	425	005	JAWWAL-PALESTINE	JAWWAL
QAT	427	001	QAT-QATARNET	Q-NET
R	635	010	R-CELL	RCELL
RA	283	001	RA-ARMGSM	ARMMO1
RC	630	002	CELTEL RC	CELTEL
REU	647	000	ORANGE RE	ORANGE
REU	647	002	F-OMT	OMT
RL	415	001	RL Cellis	CLLIS
RL	415	003	RL LibanCell	LibCL
RO	226	001	RO CONNEX	CONNEX
RO	226	003	RO COSMOROM	COSMOROM
RO	226	010	RO ORANGE	ORANGE
ROC	466	092	Chunghwa Telecom LDM	CHTLDM
RUS	250	001	MTS-RUS	MTS
RUS	250	002	MEGAFON-RUS	MEGAFON
RUS	250	004	SIBCHALLENGE RUS	RUS_SCN
RUS	250	005	SCS RUS	SCS
RUS	250	007	RUS BMT	BMT
RUS	250	010	RUS DTC	DTC
RUS	250	011	ORENSOT	ORENSOT
RUS	250	012	RUS Far East	FAR EAST
RUS	250	013	RUS KUBAN-GSM	KUGSM
RUS	250	016	RUS16 250 16	NTC
RUS	250	017	RUS 17	ERMAK
RUS	250	019	RUS INDIGO	INDIGO
RUS	250	020	TELE2	TELE2
RUS	250	028	EXTEL RUS	EXTEL
RUS	250	039	RUS SUCT	SUCT
RUS	250	044	RUS North Caucasian GSM	NC-GSM
RUS	250	092	Primetelefone RUS	Printel
RUS	250	093	TELECOM XXI RUS	TXXI
RUS	250	099	Bee Line	Bee Line
S	240	001	TELIA S	TELIA
S	240	003	ORANGE	ORANGE
S	240	007	S COMVIQ	IQ
S	240	008	VODAFONE SE	VODA SE
SA	655	001	VodaCom-SA	VODA
SA	655	007	CELL C	CELL C
SA	655	010	MTN-SA	MTN
SEZ	633	001	SEYCEL	633-01
SEZ	633	010	SEZ AIRTEL	AIRTEL
SG	525	003	SGP M1-GSM	M1-GSM
SGP	525	001	SINGTEL-G9	SINGTEL
SGP	525	002	SINGTEL-G18	SINGTEL
SGP	525	005	STARHUB-SGP	STARHUB
SI	293	040	SI.MOBIL	SI.MOBIL
SI	293	041	SI MOBITEL GSM	SI-GSM
SI	293	070	SI VEGA 070	VEGA 070
SK	231	001	ORANGE SK	ORANGE
SK	231	002	EUROTEL-SK	ET-SK
SN	608	001	SN ALIZE	ALIZE
SN	608	002	SN- SENTEL SG	SENTEL
SOM	637	001	SOM BARAKAAT	BARAKAAT
SOM	637	082	TELSOM MOBILE	TELSOM
SR	746	001	ICMS SR	ICMS
SR	746	002	SR.TELESUR.GSM	TELEG
SRI	413	002	SRI DIALOG	DIALOG
SRI	413	003	SRI - CELLTEL	CELLTEL
STP	626	001	STP CSTMOVEL	CSTMOVEL
SUD	634	001	MOBITEL SDN	MOBITEL
SV	706	002	DIGICEL	DIGICEL
SYR	417	001	SYRIATEL	SYRIATEL
SYR	417	002	94 SYRIA	94 SYRIA
SYR	417	009	SYR MOBILE SYR	MOBILE
SYR	417	093	SYRIATEL	SYRIATEL

Country Initials	MCC	MNC	Preferred Presentation of Country Initials and Mobile Network Name	Abbreviated Mobile Network Name
SZ	653	010	Swazi-MTN	SwaziMTN
TAI	466	089	T3G	T3G
TCD	622	001	CELTEL TCD	CELTEL
TD	622	002	TD LIBERTIS	LIBERTIS
TG	615	001	TG-TOGO CELL	TGCELL
TH	520	001	TH GSM	TH GSM
TH	520	015	TH ACT 1900	ACT 1900
TH	520	018	TH-DTAC	DTAC
TH	520	023	TH GSM 1800	GSM 1800
TH	520	099	ORANGE TH	ORANGE
TJK	436	003	TJK MLT	MLT
TN	605	002	TUNISIE TELECOM	TUNTEL
TON	539	001	U-CALL	U-CALL
TR	286	001	TR TURKCELL	TCELL
TR	286	002	TR TELSIM	TELSIM
TR	286	003	TR ARIA	ARIA
TR	286	004	TR AYCELL	AYCELL
TTO	374	012	TSTT	TSTT
TUN	605	003	TUNISIANA	TUNISIANA
TWN	466	001	Far Eastone	FET
TWN	466	006	TWN TUNTEX GSM 1800	TUNTEX
TWN	466	068	ACeS	ACeS
TWN	466	088	KGT-ONLINE	KGT
TWN	466	093	TWN Mobitai	TW MOB
TWN	466	097	TWN GSM 1800	TCC
TWN	466	099	TransAsia	TransAsia
TZ	640	001	Tritel-TZ	TRITEL
TZ	640	002	MOBITEL-TZ	MOBITEL
TZ	640	003	ZANTEL-TZ	ZANTEL
TZ	640	005	CELTEL-TZ	CELTEL
UA	255	001	UA UMC	UMC
UA	255	003	UA-KYIVSTAR	UA-KS
UA	255	005	UA-GT	UA-GT
UAE	424	002	UAE ETISALAT	ETSLT
UG	641	001	UG CeITel	CELTEL
UG	641	010	MTN-UGANDA	MTN-UG
UG	641	011	UTL TELCEL	UTL
UK	234	010	Q2 -UK	Q2 -UK
UK	234	015	UK VODAFONE	VODA
UK	234	020	3 UK	3 UK
UK	234	030	T-MOBILE UK	TMO UK
UK	234	031	T-MOBILE UK	TMO UK
UK	234	032	T-MOBILE UK	TMO UK
UK	234	033	ORANGE	ORANGE
UK	234	050	JT GSM	JT GSM
UK	234	055	Cable & Wireless Guensey	C&W
UK	234	058	MANX PRONTO	PRONTO
UKR	255	002	UKR-WELLCOM	WELLCOM
USA	310	011	USA Wireless 2000 Telepho	WTTCKy
USA	310	020	SPRINT	SPRINT
USA	310	026	T-MOBILE	TMO
USA	310	031	T-MOBILE	TMO
USA	310	050	DIGICEL	JAM DC
USA	310	064	USA AE AIRADIGN	ARDGMC
USA	310	150	CINGULAR WIRELESS	CINGULAR
USA	310	160	T-MOBILE	TMO
USA	310	170	CINGULAR WIRELESS	CINGULAR
USA	310	180	CINGULAR WIRELESS	CINGULAR
USA	310	200	T-MOBILE	TMO
USA	310	210	T-MOBILE	TMO
USA	310	220	T-MOBILE	TMO
USA	310	230	T-MOBILE	TMO
USA	310	240	T-MOBILE	TMO
USA	310	250	T-MOBILE	TMO
USA	310	260	T-MOBILE	TMO
USA	310	270	T-MOBILE	TMO
USA	310	310	T-MOBILE	TMO

Country Initials	MCC	MNC	Preferred Presentation of Country Initials and Mobile Network Name	Abbreviated Mobile Network Name
USA	310	340	WESTLINK COMM	WESTLINK
USA	310	350	CAROLINA PHONE	CAROLINA
USA	310	380	AT&T WIRELESS	AT&T
USA	310	410	CINGULAR WIRELESS	CINGULAR
USA	310	460	USA ONELINK	ONELINK
USA	310	530	WEST VIRGINIA WIRELESS	WVW
USA	310	560	DOBSONUS	DOBSONUS
USA	310	580	T-MOBILE	TMO
USA	310	610	EPICTOUCH	EPICTOUCH
USA	310	630	AMERILINK PCS	AMERILINK
USA	310	640	Einstein PCS	Einstein
USA	310	660	T-MOBILE	TMO
USA	310	670	WIRELESS 2000 PCS	W 2000 PCS
USA	310	680	NPI WIRELESS	NPI
USA	310	690	Conestoga	Conestoga
USA	310	740	TELEMETRIX	TELEMETRIX
USA	310	760	PTSI	PTSI
USA	310	770	IWS	IWS
USA	310	780	AIRLINK PCS	AIRLINK
USA	310	790	PinPoint	PinPoint
USA	310	800	T-MOBILE	TMO
USA	310	980	AT&T WIRELESS	AT&T
UZB	434	001	BUZTEL	BUZTEL
UZB	434	002	UZMACOM	UZMGSM
UZB	434	004	UZB DAEWOO-GSM	DW-GSM
UZB	434	005	UZB CSOCOM GSM	COSCOM
UZB	434	007	UZB UZD	UZDGSM
VN	452	001	VN MOBIFONE	VMS
VN	452	002	VN VINA FONE	GPC
VUT	541	001	VUT SMILE	SMILE
VZ	734	001	VZ INFO	INFONT
VZ	734	002	DIGITEL	DIGITEL
YE	421	002	SPACETEL	SPACETEL
YEM	421	001	YEM-SABA	SABAFON
YU	220	001	YU MOBTTEL	MOBTTEL
YU	220	002	PROMONTE	PROMONTE
YU	220	003	Yug 03	YU MTS
YU	220	004	MONET	MONET
ZM	645	001	ZM CELTEL	CELTEL
ZW	648	001	ZW NET*ONE	64801
ZW	648	003	TELECEL ZW	TELECEL
ZW	648	004	ZW ECONET	ECONET

APPENDIX B - DATA COMMANDS AND MULTIPLEXING, CPHS INFORMATION FIELD, AND CSP CONSTANTS

Data Commands and Multiplexing

The multiplexing protocol operates between a DCE (Data Communication Equipment: the product) and a DTE (Data Terminal Equipment). It allows a double session over a serial link interface: one for AT commands and one for DATA communications.

AT+WMUX=1 activates the Multiplexing Mode. With this mode, AT commands and DATA are encapsulated in packets. The header of these packets allows recognition of a DATA packet or an AT command packet. AT+WMUX=0 deactivates the Multiplexing Mode and gets the product back to the default mode.

This appendix presents how the multiplexing mode handles DATA and AT command flow. It also describes the format of DATA packets and AT command packets.

AT Command Packets

An AT command is encapsulated in a packet with a header, which allows to separate it from DATA packets. This packet is formed by a header (3 bytes), the AT command itself, and a checksum (1 byte):

B7	B6	B5	B4	B3	B2	B1	B0
Start pattern → 0xAA							
AT command length LSB							
AT command pattern → 0x1D				AT command length MSB			
AT command							
Checksum							

The 3 bytes of the header are:

- The first byte (0xAA) is used to identify the packet,
- The second byte represents the 8 LSB (Low Significant Bits) bits of the length of the AT command,
- The third byte is made of 2 parts:
 - ♦ The 3 LSB bits are the 3 MSB (Most Significant Bits) bits of the length of the AT command,
 - ♦ The 5 MSB bits (0x1D which equals to 0xE8 with the 3 bits offset) are used to identify an AT command.

The maximum length of an AT command could be 2047 bytes which is greater than all the existing AT commands.

The checksum is the addition (modulo 256) of all the transmitted bytes (header bytes and AT command bytes).

Data Packets

DATA is encapsulated into packets. These packets are composed of a header (3 bytes), the data bytes and the checksum (1 byte):

B7	B6	B5	B4	B3	B2	B1	B0
Start pattern → 0xDD							
Data packet length LSB							
Data packet type				Data packet length MSB			
Data Bytes							
Checksum							

The 3 bytes of the header are:

- The first byte (0xDD) used to identify the packet,
- The second byte represents the 8 LSB bits of the length of the data field,
- The last byte is made of 2 parts:
 - ♦ The 3 LSB bits represent the 3 MSB bits of the length of the data field,
 - ♦ The 5 MSB bits represent the packet type.

Data packets can have different values according to the type of packet:

0 – DATA Packet: The packet contains the data to transmit on the radio link or received from the radio link,

1 – STATUS Packet: The packet contains the status of SA, SB, X bits¹ and the break condition coding as follow:

SA	SB	X	BRK	RI	Spare	Spare	Spare

- ♦ The length of data for the status packet is always equal to 1,
- ♦ Whenever a status changes (except break), all the status bits are included,
- ♦ These bits are off by default (and therefore the bits DTR and RTS), so it is necessary to send a status packet to the target at the beginning of the multiplexing to start the transmission,

¹These status bits contain the V24 control information:

- ♦ SA contains DTR (signal CT108 – from terminal to IWF) and DSR (signal CT107 – from terminal to IWF),
- ♦ SB contains RTS (signal CT105 – from terminal to IWF) and DCD (signal CT109 – from IWF to terminal),
- ♦ X contains CTS (signal CT106).

For more information, refer to GSM Technical Specification 07.02

- 2 – **READY Packet:** The packet indicates that the target is ready to receive data:
 - ◆ No data are transmitted in this packet (so the length is null),
 - 3 – **BUSY Packet:** The packet indicates that the target is busy and can not receive data:
 - ◆ like the ready packet, no data are transmitted,
- Other Values:** Currently, these values are not used (reserved for future enhancement).
Checksum is calculated like the AT command packet checksum (addition of all transmitted bytes including header bytes).

Examples

AT Command and Its Answer

When there is no encapsulation, the AT command transmitted on the serial link is like this (in ASCII and hexadecimal):

ATr\n ⇔ 0x41 0x54 0x0D 0x0A

The answer is like this:

\r\nOK\r\n ⇔ 0x0D 0x0A 0x4F 0x4B 0x0D 0x0A

With the encapsulation in the serial link, the packet transmitted is (in hexadecimal):

0xAA 0x04 0xE8 0x41 0x54 0x0D 0x0A 0x42

And the answer is like this:

0xAA 0x06 0xE8 0x0D 0x0A 0x4F 0x4B 0x0D 0x0A 0x60

Initialization and Data Packet

When the Multiplexing Mode is activated (+WMUX=1), the product sends 2 Data packets after the establishment of a DATA call (after the CONNECT xxxx message): 1 READY Packet and 1 STATUS Packet. To set the different signals to the right value, it is necessary to send a STATUS packet to the product. Here are some examples of STATUS packets:

0xDD 0x01 0x08 0x40 0x26 ⇔ bit RTS is on

To start a data call, all the bits should be on:

0xDD 0x01 0x08 0xC0 0xA6 ⇔ bits DTR and RTS are on

Restriction

The autobauding mode is not available when the Multiplexing Mode is activated: the serial link speed must be set to a fixed rate.

CPHS Information Field

CPHS Information		
Description	Data Field	Bit Field
All information	0	None
CSP service activated and allocated	1	0
SST service activated and allocated	2	1
Mailbox Number service activated and allocated	3	2
Operator Name Shortform service activated and allocated	4	3
Information Numbers service activated and allocated	5	4
RFU	6	5
RFU	7	6
RFU	8	7
Voice Message Waiting Indicator for Line 1	9	8
Voice Message Waiting Indicator for Line 2	10	9
Data Message Waiting Indicator	11	10
Fax Message Waiting Indicator	12	11
Call Forward Activated Indicator for Line 1	13	12
Call Forward Activated Indicator for Line 2	14	13
Call Forward Activated Indicator for Data	15	14
Call Forward Activated Indicator for Fax	16	15
Reserved	17	16
Reserved	18	17
Reserved	19	18
Reserved	20	19
Line 1 Mailbox Number Available	21	20
Line 2 Mailbox Number Available	22	21
Date Mailbox Number Available	23	22
Fax Mailbox Number Available	24	23
EF Mn Updatable	25	24

CSP Constants

Service Group: Call Offering

Service	External Value
Call Forwarding Unconditional	1
Call Forwarding on User Busy	2
Call Forwarding on No Rely	3
Call Forwarding on User Not Reachable	4
Call Transfer	5

Service Group: Call Restriction

Service	External Value
Barring of All Outgoing Calls	9
Barring of Outgoing International Calls	10
Barring of Outgoing International Calls except those directed to the Home PLMN country	11
Barring of All Outgoing Calls	12
BIC Roam	13

Service Group: Other Supplementary Services

Service	External Value
Multi-Party Service	17
Closed User Group	18
Advice of Charge	19
Perferential CUG	20
CUG Outgoing Access	21

Service Group: Group Completion

Service	External Value
Call Hold	25
Call Waiting	26
Completion of Call to Busy Subscriber	27
Restriction of the menus allowing use of user to user signalling	28

Service Group: Teleservices

Service	External Value
Short Message – Mobile Terminated	33
Short Message – Mobile Originated	34
Short Message – Cell Broadcast	35
Restricts menu options for the ability to set reply path active on outgoing Short Messages	36
SMS Delivery Confirmation	37
Restriction of menus for SMS Protocol ID options	38
Validity Period, restriction of menus for SMS Validity period options	39

Service Group: CPHS Teleservices

Service	External Value
Alternate Line Service	41

Service Group: Number Identification

Service	External Value
Calling Line Identification Presentation	57
Connected Line Identification Restriction	59
Connected Line Identification Presentation	60
Malicious Call Indicator	61
CLI per call mode – default block CLI – menu to send CLI	63
CLI per call mode – default block CLI – menu to block CLI	64

Service Group: Phase 2+ Services

Service	External Value
Menus concerned with GPRS functionality	65
Menus concerned with High Speed Circuit Switched Data functionality	66
ASCII Voice Group call menus	67
ASCII Voice Broadcast service menus	68
Multi Subscriber profile menus	69
Multi band: Restriction of menus allowing user to select a particular GSM 900/1800 or 1900 band	70

Service Group: Value Added Services

Service	External Value
Restriction of menu options for manual PLMN selection	73
Restriction of menu options for Voice Mail or other similar menus	74
Restriction of menu options for the ability to send Short Messages with type Paging	75
Restriction of menu options for the ability to send Short Messages with type Email	76
Restriction of menu options for Fax calls	77
Restriction of menu options for Data calls	78
Restriction of menu allowing the user to change language	80

Service Group: Information Numbers

Service	External Value
The ME shall only present information numbers to the user if this field is set to FF	81

APPENDIX C - AT COMMAND EXAMPLES

Examples

Example: When a PIN Is Required

Example 1: When the ME has to be powered ON.

```

AT+CMEE=1      Enable the report mobile equipment errors.
OK
AT+CREG=1      Report registration.
OK
AT+CPAS        Query ME Status.
+CPAS: 5       (ME is asleep)
OK
AT+CFUN=1      Set ME to full functionality.
OK
AT+COPS=0      Ask for automatic operator selection and registration.
+CME ERROR: 11 SIM PIN required.
AT+CPIN=1234   User entered a wrong PIN.
+CME ERROR: 16 Incorrect password.
AT+CPIN=0000
OK             PIN OK.
AT+COPS=0      Ask for automatic operator selection and registration.
OK
+CREG:1        Registered on the network.
AT+COPS=3,0    Select the long name alphanumeric format.
OK
AT+COPS?       Get the operator name.
+COPS: 0,0,"I OMNITEL"
OK

```

Example 2: When the ME has already been powered ON

```

AT+CMEE=1      Enable the report mobile equipment errors.
OK
AT+CPAS        Get the ME Status.
+CPAS: 0       ME is ready to receive commands.
OK
AT+CPIN?       Is ME requiring a password?
+CPIN: SIM PIN Yes, SIM PIN required.
AT+CPIN=0000
OK             PIN OK.

```

Example: When a Voice Call Is Originated

When the ME is powered on and the SIM PIN has been entered

```

AT+CMEE=1      Enable the reporting of mobile equipment errors.
OK
AT+WIND=63     Ask to display the general indications.
OK
AT+CPIN?       Is ME requiring a password?
+CPIN: READY   Product is ready.
ATD0607103543; Make a voice call.
+WIND: 5,1     Indication of call.
+WIND: 2       Remote party is ringing.
OK             Call setup was successful.
Conversation...
ATH            Release the call.
OK

```

Incoming Calls Examples

When the ME is powered ON and the SIM PIN has been entered

AT+CMEE=1 *Enable the report mobile equipment errors.*
 OK
 AT+WIND=63 *Ask to display the general indications.*
 OK
 AT+CLIP=1 *Enable the calling line identification presentation.*
 OK
 AT+CRC=1 *Enable extended format of incoming indication.*
 OK
 AT+CNUM *Query own number (voice number) or MSISDN.*
 +CNUM: *"Speech", "+33608971019", 145.*
 OK
Call this number from another equipment.
 +WIND: 5,1 *Indication of call (Ring).*
 +CRING: Voice *Type of call is VOICE.*
 +CLIP: "+33607103543",145,,,"John Panborn" *Identification of the remote party.*
 +CRING: Voice
 ATA *Answer the call.*
 OK
 ...Conversation...
 NO CARRIER *The call has been released by the remote party.*
 +WIND: 6,1 *Indication of call release.*

Phonebook Examples

For each example illustrated in this section, the ME is supposed to have been powered on and the SIM PIN entered.

Example 1: The whole phonebook of the ME is read.

AT+CPBS=? *Query supported phonebook memories.*
 +CPBS: ("SM","FD","ON") *ADN, FDN, and MSISDN phonebooks supported.*
 AT+CPBS="SM" *Select ADN phonebook.*
 OK
 AT+CPBR=? *Read the index range and the length of the elements.*
 +CPBR: (1-80),20,14 *80 locations (from 1 to 80), max length of 20 for the phone number, 14 characters max for the text.*
 AT+CLIP=1 *Enable the calling line identification presentation.*
 AT+CPBR=1,80 *Read all entries (only the ones set are returned).*
 +CPBR: 1,"0346572834",129,"Delores Clairborne"
 +CPBR: 2,"1284374523",129,"Thad Beaumont"
 +CPBR: 3,"1243657845",129,"John Panborn"
 OK

Example 2: Erase or Write a phonebook entry.

AT+CPBW=? *Get the phonebook type.*
 +CPBW: (1-80),20,(129,145),14 *80 locations, max length of 20 for the phone number, TON/NPI of 129 or 145 and 14 characters max for text.*
 AT+CPBW=3 *Erase location 3.*
 OK
 AT+CPBW=3, "4356729012",129,"Carry" *Write at location 3.*
 OK
 AT+CPBR=1,80 *Read all entries (only the ones set are returned).*
 +CPBR: 1,"0346572834",129,"Delores Clairborne"
 +CPBR: 2,"1284374523",129,"Thad Beaumont"
 +CPBR: 3,"1243657845",129,"John Panborn"
 OK

Example 3: Find phonebook entries.

AT+CPBW=? *Get the phonebook type.*
 +CPBF: 20,14 *Max length of 20 for the phone number, 10 characters for the text.*
 AT+CPBF="D" *Read entries starting with "D".*
 +CPBF: 1,"0346572834",129,"Delores Clairborne"
 OK
 AT+CPBF="W" *Read entries starting with "W".*
 +CME ERROR: 22 *Entry not found.*

Examples of Short Messages

Example 1: Send a short message.

AT+CNMI=0,1,1,1,0	<i>SMS-DELIVERs are directly stored. SMS-STATUS-REPORTs are displayed.</i>
OK	
AT+CSMP=17,169,0,0	<i>SMS-SUBMIT message with a validity period (one day).</i>
OK	
AT+CMGF=1 ""	<i>Text mode to send a Short Message.</i>
OK	
AT+CSCA="+33608080706"	<i>Set Service Center Address to +33608080706.</i>
OK	
AT+CMGS=0601290800	<i>Send a SMS-SUBMIT to mobile phone.</i>
This is the first text line	<i>Product sends a 4-character sequence: 0x0D 0x0A 0x3E 0x20.</i>
This is the last text line	<i>Edit first line and press carriage return (<CR>, 0x0D).</i>
+CMGS: 5	<i>Edit last line and send message by pressing <ctrl-Z> (0x1A).</i>
+CDS: 2,5,"0601290800",129,"99/05/01 14:15:10+04.	<i>Success: message reference 5 is returned from the SMS Service Center.</i>
" " " "	<i>Success: report of successful message delivery received.</i>

Example 1: Read a short message.

AT+CMGF=1	<i>Text mode to read Short Messages.</i>
AT+CMGL="ALL"	<i>List all stored messages.</i>
+CMGL: 1,"REC READ","+336290918",,"99/05/01 14:15:10+04"	<i>This is the first message.</i>
I will be late.	
+CMGL: 2,"REC UNREAD","+336290918",,"99/05/01 14:19:44+04"	<i>This is the second message.</i>
Traffic jam on Broadway.	
OK	
AT+CMGR=1 ""	<i>Read the first message.</i>
+CMGR: "REC READ","+336290918",,"99/05/01 14:19:44+04"	
OK	

Fax Class 2 Examples

The normal characters are generated DTE. The bold characters are modem generated.

Example 1: Send a fax Class 2.

AT+FCLASS=2	Select fax class 2.
OK	
AT+FLID="LocalFax"	
OK	
ATD0601234567	<i>Call establishment.</i>
+FCON	<i>Connection OK.</i>
[+FCSI:"RemoteFax"]	
+FDIS:0,3,0,2,0,0,0,0	
OK	
AT+FDT	<i>Beginning of the data transfer.</i>
+FDCS:0,3,0,2,0,0,0,0	
CONNECT	
<0x11h>	<i>Send carrier.</i>
	<i>First page data terminated by <0x10h><0x03h>.</i>
OK	<i>Page transmitted.</i>
AT+FET=0	<i>Send another page.</i>
+FPTS:1	<i>First page acquitted.</i>
OK	
AT+FDT	
CONNECT	
<0x11h>	<i>Send carrier.</i>
	<i>Second page data terminated by <0x10h><0x03h>.</i>
OK	<i>Page transmitted.</i>
AT+FET=2	<i>No more pages.</i>
+FPTS:1	<i>First page acknowledged.</i>
+FHNG:0	<i>Normal end of connection.</i>
OK	

Example 2: Receive a fax Class 2.

```

AT+FCR=1
OK
AT+FLID="LocalFax"
OK
RING                               Incoming call.
ATA                                 Answer.
+FCON                               Connection OK.
  [+FTSI:"RemoteFax"]
  +FDCS:0,3,0,2,0,0,0,0
  OK
AT+FDR
+FCFR
+FDCS:0,3,0,2,0,0,0,0
CONNECT
<0x12h>                             Receive page carrier.
First page data terminated by
<0x10h><0x03h>
OK                                 Page received.
+FPTS:1                             First page acknowledged.
+FET:0                               To receive another page.
OK
AT+FDR
+FDCS:0,3,0,2,0,0,0,0
CONNECT
<0x12h>                             Receive page carrier.

Second page data terminated by
<0x10h><0x03h>
OK                                 Page received
+FPTS:1                             Second page acknowledged.
+FET:2                               No more page to receive.
OK
AT+FDR
+FHNG:0                             Normal end of connection.
OK

```

APPENDIX D - ME SIM TOOLKIT SUPPORT

TABLE 1 – Support of SIM ToolKit classes

This has been extracted from the GSM Technical Specification 11.14.

Command description	Class 1	Class 2	Class 3
CALL CONTROL		X	X
CELL BROADCAST DOWNLOAD		X	X
DISPLAY TEXT		X	X
EVENT DOWNLOAD			
- MT call			X
- Call connected			X
- Call disconnected			X
- Location status			X
- User activity			X
- Idle screen available			X
GET INKEY		X	X
GET INPUT		X	X
GET READER STATUS \$(MultipleCard)\$			Lc
MENU SELECTION		X	X
MO SHORT MESSAGE CONTROL			X
MORE TIME		X	X
PERFORM CARD APDU \$(MultipleCard)\$			Lc
PLAY TONE		X	X
POLLING OFF		X	X
POLL INTERVAL		X	X
POWER ON CARD \$(MultipleCard)\$			Lc
POWER OFF CARD \$(MultipleCard)\$			Lc
PROVIDE LOCAL INFORMATION		X	X
REFRESH	X	X	X
RUN AT COMMAND \$(AT\$)			Lc
SELECT ITEM		X	X
SEND SHORT MESSAGE		X	X
SEND SS		X	X
SEND USSD			X
SET UP CALL		X	X
SET UP EVENT LIST			X
SET UP IDLE MODE TEXT \$(IdleModeText)\$			X
SET UP MENU		X	X
SMS-PP DOWNLOAD	X	X	X
TIMER MANAGEMENT \$(Timer)\$			Lc
TIMER EXPIRATION \$(Timer)\$			Lc

TABLE 2 - Compatibility between available Terminal Responses and Proactive Commands

Terminal Responses	Proactive commands											
	Setup Menu (0)	Display Text (1)	Get Inkey (2)	Get Input (3)	Setup Call (4)	Play Tone (5)	Select Item (6)	Refresh (7)	Send SS (8)	Send SMS (9)	Send USSD (10)	Setup event list (11)
Backward Move (95)		•	•	•			•					
Command beyond ME capabilities (96)	•	•	•	•	•	•	•	•	•	•	•	•
ME currently unable to process command (97)	•	•	•	•	•	•	•	•	•	•	•	•
No response from the user (98)		•	•	•			•					
SIM session terminated by the user (99)		•	•	•	•	•	•					

APPENDIX E - STRUCTURE OF THE TERMINAL PROFILE

First byte (Download):

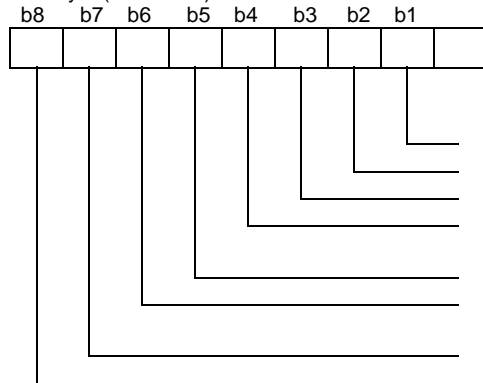

- Profile download **User choice**
- SMS-PP data download **Set by product to 1**
- Cell Broadcast data download **Set by product to 1**
- Menu selection **User choice**
- '9E XX' response code for SIM data download error **Set by product to 1**
- Timer expiration **Set by product to 0**
- USSD string data object supported in Call Control **User choice**
- RFU, bit=0

Second byte (Other):

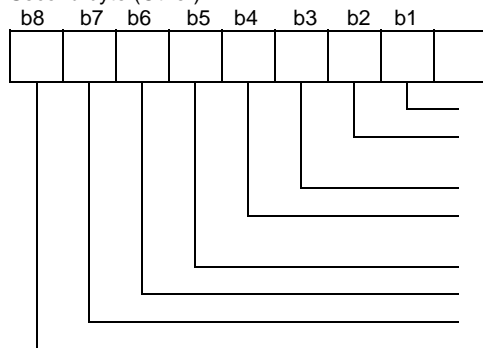

- Command result **User choice**
- Call Control by SIM **User choice**
- Cell identity included in Call Control by SIM **User choice**
- MO short message control by SIM **User choice**
- Handling of the alpha identifier according to subclause 9.1.3 **User choice**
- UCS2 Entry supported **User choice**
- UCS2 Display supported **User choice**
- Display of the extension text **User choice**

Third byte (Proactive SIM):

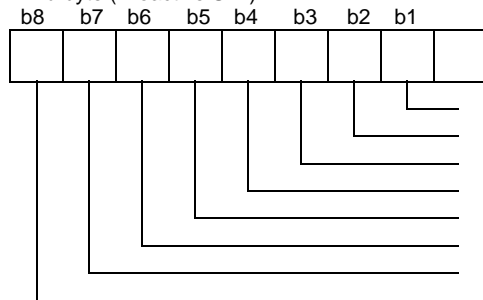

- Proactive SIM: DISPLAY TEXT **User choice**
- Proactive SIM: GET INKEY **User choice**
- Proactive SIM: GET INPUT **User choice**
- Proactive SIM: MORE TIME **User choice**
- Proactive SIM: PLAY TONE **User choice**
- Proactive SIM: POLL INTERVAL **Set by product to 1**
- Proactive SIM: POLLING OFF **Set by product to 1**
- Proactive SIM: REFRESH **User choice**

Fourth byte (Proactive SIM):

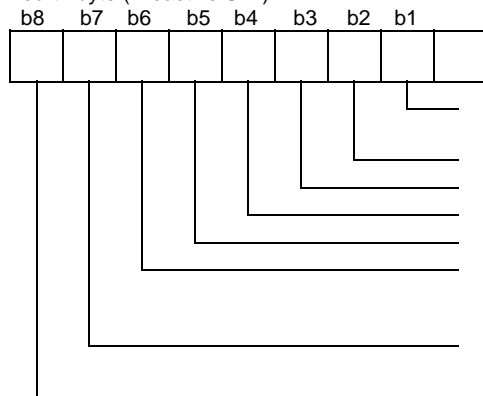

- Proactive SIM: SELECT ITEM **User choice**
- Proactive SIM: SEND SHORT MESSAGE **User choice**
- Proactive SIM: SEND SS **User choice**
- Proactive SIM: SEND USSD **User choice**
- Proactive SIM: SET UP CALL **User choice**
- Proactive SIM: SET UP MENU **User choice**
- Proactive SIM: PROVIDE LOCAL INFORMATION (MCC, MNC, LAC, Cell ID & IMEI) **Set by product to 1**
- Proactive SIM: PROVIDE LOCAL INFORMATION (NMR) **Set by product to 1**

Fifth byte (Event driven information):

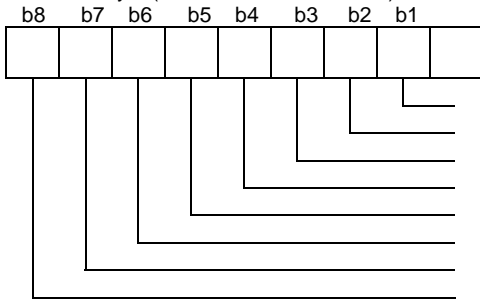

Proactive SIM: SET UP EVENT LIST
 Event: MT call
 Event: Call connected
 Event: Call disconnected
 Event: Location status
 Event: User activity
 Event: Idle screen available
 Event: Card reader status

Set by product to 1
Set by product to 1
Set by product to 1
Set by product to 1
Set by product to 1
 User choice
 User choice
 Set by product to 0

Sixth byte: (reserved for Event driven information extensions)

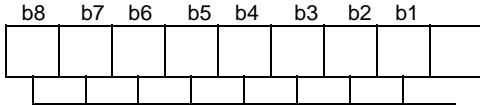

RFU, bit = 0

Seventh byte (Multiple card proactive commands) for class "a"

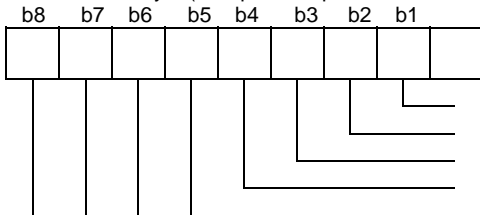

Proactive SIM: POWER ON CARD
 Proactive SIM: POWER OFF CARD
 Proactive SIM: PERFORM CARD APDU
 Proactive SIM: GET READER STATUS
 RFU, bit = 0

Set by product to 0
Set by product to 0
Set by product to 0
Set by product to 0
Set by product to 0

Eighth byte (Proactive SIM):

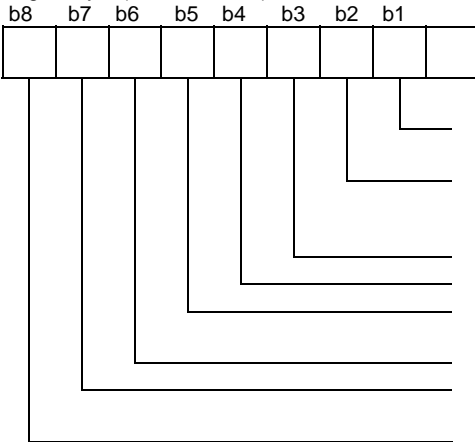

Proactive SIM: TIMER MANAGEMENT (start, stop)
 Proactive SIM: TIMER MANAGEMENT (get current value)
 Proactive SIM: PROVIDE LOCAL INFORMATION (date, time and time zone)
 Binary choice in GET INKEY
 SET UP IDLE MODE TEXT
 RUN AT COMMAND (e.g., class "b" is supported)
 2nd alpha identifier in SET UP CALL
 2nd capability configuration parameter (see 9.1.6)

Set by product to 1
Set by product to 1
Set by product to 0
Set by product to 0
Set by product to 0
Set by product to 0
Set by product to 0
Set by product to 0

Ninth byte:

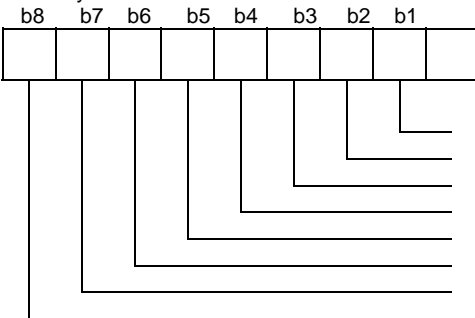

Sustained DISPLAY TEXT (see 6.4.1)
 SEND DTMF command (see 6.4.24)
 RFU, bit = 0
 RFU, bit = 0
 RFU, bit = 0
 RFU, bit = 0
 RFU, bit = 0
 RFU, bit = 0

Set by product to 0
Set by product to 0

Subsequent bytes:

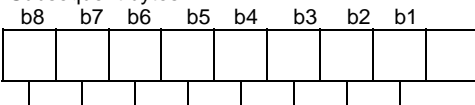

RFU, bit = 0

APPENDIX F - COMMAND TYPE AND NEXT ACTION INDICATOR

This table has been extracted from the GSM Technical Specification 11.14.

Value	Name	Used for Type of Command coding	Used for Next Action Indicator coding
'00'		-	-
'01'	REFRESH	X	
'02'	MORE TIME	X	
'03'	POLL INTERVAL	X	
'04'	POLLING OFF	X	
'05'	SET UP EVENT LIST	X	
'10'	SET UP CALL	X	X
'11'	SEND SS	X	X
'12'	SEND USSD	X	X
'13'	SEND SHORT MESSAGE	X	X
'14'	SEND DTMF	X	
'20'	PLAY TONE	X	X
'21'	DISPLAY TEXT	X	X
'22'	GET INKEY	X	X
'23'	GET INPUT	X	X
'24'	SELECT ITEM	X	X
'25'	SET UP MENU	X	X
'26'	PROVIDE LOCAL INFORMATION	X	
'27'	TIMER MANAGEMENT	X	
'28'	SET UP IDLE MODE TEXT	X	X
'30'	PERFORM CARD APDU	class "a" only	X
'31'	POWER ON CARD	class "a" only	X
'32'	POWER OFF CARD	class "a" only	X
'33'	GET READER STATUS	class "a" only	X
'34'	RUN AT COMMAND	class "b" only	
'81'	End of the proactive session	not applicable	X

APPENDIX G - CODING OF ALPHA FIELDS IN THE SIM FOR UCS2

The coding can take one of the three following structures. If the ME supports UCS2 coding of alpha fields in the SIM, the ME shall support all three coding schemes for character sets containing 128 characters or less; for character sets containing more than 128 characters, the ME shall at least support the first coding scheme. If the alpha field record contains GSM default alphabet characters only, then none of these schemes shall be used in that record. Within a record, only one coding scheme, either GSM default alphabet, or one of the three described below, shall be used.

1. If the **first byte in the alpha string is '0x80'**, then the other bytes are 16 bit UCS2 characters. The more significant byte (MSB) of the UCS2 character is coded in the lower numbered byte of the alpha field, and the less significant byte (LSB) of the UCS2 character is coded in the higher numbered alpha field byte. In other words, byte 2 of the alpha field contains the more significant byte (MSB) of the first UCS2 character, and byte 3 of the alpha field contains the less significant byte (LSB) of the first UCS2 character (as shown below). Unused bytes shall be set to 'FF', and if the alpha field has an even number of bytes, then the last (unusable) byte shall be set to 'FF'.

Example 1

Byte 1	Byte 2	Byte 3	Byte 4	Byte 5	Byte 6	Byte 7	Byte 8	Byte 9
'80'	Ch1 _{MSB}	Ch1 _{LSB}	Ch2 _{MSB}	Ch2 _{LSB}	Ch3 _{MSB}	Ch3 _{LSB}	'FF'	'FF'

2. If the **first byte of the alpha string is set to 0x'81'**, then the second byte contains a value indicating the number of characters in the string. The third byte contains an 8-bit number that defines bits 15 to 8 of a 16-bit base pointer, where bit 16 is set to zero, and bits 7 to 1 are also set to zero. These sixteen bits represent a base pointer to a "half-page" in the UCS2 code space, to be used with some or all of the remaining bytes in the string. The fourth and subsequent bytes in the string contain codings as follows:
 - If bit 8 of the byte is set to zero, the remaining bits of the byte contain a GSM Default Alphabet character
 - If bit 8 of the byte is set to one, then the remaining bits are an offset value added to the 16-bit base pointer defined by byte 3, and the resulting 16-bit value is a UCS2 code point and defines a UCS2 character.

Example 2

Byte 1	Byte 2	Byte 3	Byte 4	Byte 5	Byte 6	Byte 7	Byte 8	Byte 9
'81'	'05'	'13'	'53'	'95'	'A6'	'XX'	'FF'	'FF'

In the above example:

- Byte 2 indicates there are 5 characters in the string
 - Byte 3 indicates bits 15 to 8 of the base pointer, and indicates a bit pattern of 0hhh hhhh h000 0000 as the 16 bit base pointer number. Bengali characters for example start at code position 0980 (*0000 1001 1000 0000*), which is indicated by the coding '13' in byte 3 (shown by the italicized digits).
 - Byte 4 indicates GSM Default Alphabet character '53'; e.g., "S".
 - Byte 5 indicates a UCS2 character offset to the base pointer of '15', expressed in binary as follows 001 0101, which, when added to the base pointer value results in a sixteen bit value of *0000 1001 1001 0101*, e.g.. '0995', which is the Bengali letter KA.
 - Byte 8 contains the value 'FF', but as the string length is 5, this a valid character in the string, where the bit pattern 111 1111 is added to the base pointer, yielding a sixteen bit value of *0000 1001 1111 1111* for the UCS2 character (e.g.. '09FF').
 - Byte 9 contains the padding value 0xFF.
3. If the **first byte of the alpha string is set to '0x82'**, then the second byte contains the length of the string (number of characters). The third and fourth bytes contain a 16-bit number that defines the complete 16-bit base pointer to a "half-page" in the UCS2 code space for use with some or all of the remaining bytes in the string. The fifth and subsequent bytes in the string contain coding as follows:
 - If bit 8 of the byte is set to zero, the remaining 7 bits of the byte contain a GSM Default Alphabet character
 - If bit 8 of the byte is set to one, the remaining 7 bits are an offset value added to the base pointer defined in bytes three and four, and the resultant 16 bit value is a UCS2 code point, and defines a UCS2 character.

Example 3

Byte 1	Byte 2	Byte 3	Byte 4	Byte 5	Byte 6	Byte 7	Byte 8	Byte 9
'82'	'05'	'05'	'30'	'2D'	'82'	'D3'	'2D'	'31'

In the above example

- Byte 2 indicates there are 5 characters in the string
- Bytes 3 and 4 contain a sixteen bit base pointer number of '0530', pointing to the first character of the Armenian character set.
- Byte 5 contains a GSM Default Alphabet character of '2D', which is a dash "-".
- Byte 6 contains a value '82', which indicates it is an offset of '02' added to the base pointer, resulting in a UCS2 character code of '0532', which represents Armenian character Capital BEN.
- Byte 7 contains a value 'D3', an offset of '53', which when added to the base pointer results in a UCS2 code point of '0583', representing Armenian Character small PIWR.

APPENDIX H - SPECIFICATION OF POWER DOWN CONTROL VIA RS232

This appendix describes how the power down mode of the product can be activated and deactivated via the RS232 serial link. Refer to +W32K to activate or deactivate the power down mode.

In this appendix, the term “DTE” refers to the customer device driving the product, which is referred to as the “DCE”. The terms referring to the RS232 signals and levels are used according to recommendations V.24 and V.28. However they are worth at remembering:

- DTR is the circuit 108/2
- TX is the circuit 103
- RX is the circuit 102
- CTS is the circuit 106
- The logical level “HIGH or ON” corresponds to the electrical level of 12V, and the level “LOW or OFF” corresponds to –12 V
- The activation and deactivation are always initiated from the DTE and is carried out through the handshaking of DTR and CTS

The power down mode can be entered only when the DCE is idle; that means when there is no connection to the network is in progress. Into the details:

Whenever the DTE requests the DCE to enter the power down mode, the DTE drops (ON-to-OFF transition) DTR. From this time on, the DTE **must not send** any more characters on the TX line. The TX FIFO must be empty.

The DCE acknowledges entry in the power down mode by dropping CTS within an interval of 5s after the DTR drop. However, during that period the DTE is prohibited from sending any more AT commands.

AT responses can be sent back to the DTE even if the DCE is in power down mode (actually the DCE exits the power down mode, sends the AT response and enters back the power down mode). Therefore, the DTE can drop DTR just after sending an AT command and before receiving the AT response.

The DCE is made to exit the power down mode by raising the DTR. DCE is not ready to receive further AT commands until it raises in turn CTS, which can take up to 2s from the DTR raise.

Diagram Depicting Handshaking:

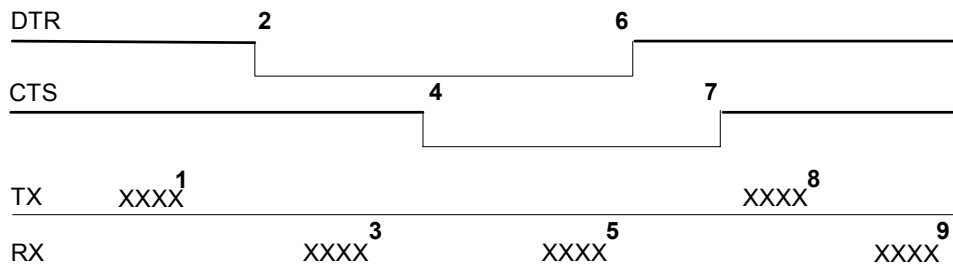

Description of the stages:

- 1: the DTE sends an AT command
- 2: the DTE drops DTR to make the DCE enter the power down mode. Warning: this mode will not really enter until CTS is dropped (stage 4). The DTE could also have dropped DTR after receiving the AT response (stage 3).
- 3: the DCE sends back the AT response (if any)
- 4: the DCE drops CTS and does enter the power down mode.
- 5: the DCE sends back an unsolicited response (for instance a RING or +SMTI (incoming SMS indication))
- 6: the DTE wants to reply to that unsolicited response so it causes the DCE to exit the power down mode by raising its DTR.
- 7: in turn the DCE acknowledges the exit of the power down mode by raising CTS.
- 8) & 9) exchange of AT commands/responses.

Note 1): The DTE must not send any AT commands from stage 2 on up to stage 7.

Note 2): During the latency period (between stages 2 and 4) should the DTE want to abort the power down mode, it raises DTR and should wait for 150us before assessing CTS. If CTS is still high then the DCE has aborted the power down mode and is ready to receive AT commands.

The 150us wait should get around the race condition between DTR raise and CTS drop.

APPENDIX I - CONDITIONS FOR COMMAND EXECUTION AND SIM DEPENDENCE

The following table lists AT command execution syntax and the execution condition. The SIM dependency column indicates if the command behavior will vary if another card is used. For example, it will vary for phonebook reading commands. The Intermediate column indicates if intermediate response can occur.

General Commands

AT Commands	Conditions	SIM dependence	Intermediate
AT+CGMI	None	N	N
AT+CGMM	None	N	N
AT+CGMR	None	N	N
AT+CGSN	None	N	N
AT+CSCS	+WIND: 4	N	N
AT+WPCS	+WIND: 4	N	N
AT+CIMI	+WIND: 4	Y	N
AT+CCID	+WIND: 1	Y	N
AT+GCAP	None	N	N
A/	Depends on previous command	Depends on prev. command	N
AT+CPOF	+WIND: 3 without SIM, +WIND: 1 with SIM	N	N
AT+CFUN	None	N	N
AT+CPAS	None	N	N
AT+CMEE	None	N	N
AT+CKPD	Depends of the sequence used	Y/N	N
AT+CCLK	+WIND: 4	Y	N
AT+CALA	None	N	Y

Call Control Commands

AT commands	Conditions	SIM dependence	Intermediate
ATD	Depends of sequence used	Y/N	Y
ATH	None	N	N
ATA	None	N	N
AT+CEER	+WIND: 4	Y	N
AT+VTD	None	N	N
AT+VTS	None	N	N
ATDL	None	N	Y
AT%D	None	N	N
ATSO	None	N	N
AT+CICB	None	N	N
AT+CSNS	None	N	N
AT+VGR	None	N	N
AT+VGT	None	N	N
AT+CMUT	None	N	N
AT+SPEAKER	None	N	N
AT+ECHO	None	N	N
AT+SIDET	None	N	N
AT+VIP	None	N	N
AT+DUI	PIN	N	N
AT+HUI	PIN	N	N
AT+RUI	PIN	N	N

Network Service Commands

AT commands	Conditions	SIM dependence	Intermediate
AT+CSQ	None	N	N
AT+COPS	+WIND: 4	Y	N
AT+CREG	None	N	Y
AT+WOPN	None	N	N
AT+CPOL	+WIND: 7	Y	Y

Security Commands

AT commands	Conditions	SIM dependence	Intermediate
AT+CPIN	+WIND: 1	Y	N
AT+CPIN2	after PIN entered	Y	N
AT+CPINC	+WIND: 1	Y	N
AT+CLCK	+WIND: 4	Y	N
AT+CPWD	+WIND: 4	Y	N

Phonebook Commands

AT commands	Conditions	SIM dependence	Intermediate
AT+CPBS	+WIND: 4	Y	N
AT+CPBR	+WIND: 4	Y	Y
AT+CPBF	+WIND: 4	Y	Y
AT+CPBW	+WIND: 4	Y	N
AT+CPBP	+WIND: 4	Y	Y
AT+CPBN	+WIND: 4	Y	Y
AT+CNUM	+WIND: 4	Y	N
AT+WAIP	None	N	N
AT+CSVM	+WIND: 4	N	N

Short Messages Commands

AT commands	Conditions	SIM dependence	Intermediate
AT+CSMS	+WIND: 4	Y	N
AT+CNMA	+WIND: 4	Y	N
AT+CPMS	+WIND: 4	Y	N
AT+CMGF	+WIND: 4	Y	N
AT+CSAS		Y	N
AT+CRES		Y	N
AT+CSDH	+WIND: 4	Y	N
AT+CNMI	+WIND: 4	Y	N
AT+CMGR	+WIND: 4	Y	Y
AT+CMGL	+WIND: 4	Y	Y
AT+CMGS	+WIND: 4	Y	N
AT+CMGW	+WIND: 4	Y	Y
AT+CMSS	+WIND: 4	Y	N
AT+CSMP	+WIND: 4	Y	N
AT+CMGD	+WIND: 4	Y	N
AT+CSCA		Y	N
AT+CSCB	+WIND: 4	Y	N
AT+WCBM	+WIND: 4	Y	N
AT+WMSC	+WIND: 4	Y	Y
AT+WMGO	+WIND: 4	Y	N
AT+WUSS	None	N	N

Supplementary Services Commands

AT commands	Conditions	SIM dependence	Intermediate
AT+CCFC	+WIND: 4	Y	N
AT+CLCK	+WIND: 4	Y	N
AT+CPWD	+WIND: 4	Y	N
AT+CCWA	+WIND: 4	Y	N
AT+CLIR	+WIND: 4	Y	N
AT+CLIP	+WIND: 4	Y	N
AT+COLP	+WIND: 4	Y	N
AT+CAOC	+WIND: 4	Y	Y
AT+CACM	+WIND: 4	Y	N
AT+CAMM	+WIND: 4	Y	N
AT+CPUC	+WIND: 4	Y	N
AT+CHLD	+WIND: 4	Y	N
AT+CLCC	None	N	N
AT+CSSN	None	N	N
AT+CUSD	None	N	N
AT+CCUG	+WIND: 4	Y	Y

Data Commands

AT commands	Conditions	SIM dependence	Intermediate
AT+CBST	None	N	N
AT+FCLASS	None	N	N
AT+CR	None	N	N
AT+CRC	None	N	N
AT+ILRR	+WIND: 4	N	N
AT+CRLP	None	N	N
AT+DOPT	None	N	N
AT%C	None	N	N
AT+DS	None	N	N
AT+DR	None	N	N
IN	None	N	N

Fax Commands

AT commands	Conditions	SIM dependence	Intermediate
AT+FTM	None	N	N
AT+FRM	None	N	N
AT+FTH	None	N	N
AT+FRH	None	N	N
AT+FTS	None	N	N
AT+FRS	None	N	N

Class 2 Commands

AT commands	Conditions	SIM dependence	Intermediate
AT+FDT	None	N	N
AT+FDR	None	N	N
AT+FET	None	N	N
AT+FPTS	None	N	N
AT+FK	None	N	N
AT+FBOR	None	N	N
AT+FBUF	None	N	N
AT+FCQ	None	N	N
AT+FCR	None	N	N
AT+FDIS	None	N	N
AT+FDCC	None	N	N
AT+FLID	None	N	N
AT+FPHCTO	None	N	N

V24-V25 Commands

AT commands	Conditions	SIM dependence	Intermediate
AT+IPR	None	N	N
AT+ICF	None	N	N
AT+IFC	None	N	N
AT&C	None	N	N
AT&D	None	N	N
AT&S	None	N	N
ATO	+WIND: 4	N	N
ATQ	None	N	N
ATV	None	N	N
ATZ	None	N	N
AT&W	None	N	N
AT&T	None	N	N
ATE	None	N	N
AT&F	None	N	N
AT&V	None	N	N
ATI	None	N	N
AT+WMUX	None	N	N

Specific AT Commands

AT commands	Conditions	SIM dependence	Intermediate
AT+CCED	None	N	N
AT+WIND	None	N	N
AT+ADC	None	N	N
AT+CMER	None	N	N
AT+WLPR	+WIND: 1	N	N
AT+WLPW	+WIND: 1	N	N
AT+WIOR	None	N	N
AT+WIOV	None	N	N
AT+WIOV	None	N	N
AT+WAC	None	N	N
AT+WZONE	None	N	N
AT+WDTMF	None	N	N
AT+WDWL	None	N	N
AT+WVR	None	N	N
AT+WDR	None	N	N
AT+WSVG	None	N	N
AT+WSTR	None	N	N
AT+WSCAN	None	N	N
AT+WRIM	None	N	N
AT+W32K	None	N	N
AT+WCDM	None	N	N
AT+WCCS	+WIND: 4	N	N
AT+WLCK	None (PIN for auto CNL)	N (Y for auto CNL)	N
AT+CPHS	+WIND: 4	Y	N
AT+WMIR	None	N	N
AT+WCDP	None	N	N
AT+WMBN	PIN	Y	N
AT+WOPEN	None	N	N
AT+WRST	None	N	N
AT+WSSST	None	N	N

SIM ToolKit Commands

AT commands	Conditions	SIM dependence	Intermediate
AT+STSF	None	N	N
AT+STIN	+WIND: 4	Y	N
AT+STGI	+WIND: 4	Y	N
AT+STGR	+WIND: 4	Y	N

INDEX

	%	
%C Select data compression.....		84
%D Automatic dialing with DTR.....		23
	&	
&C Set DCD signal.....		95
&D Set DTR signal.....		96
&F Restore factory settings.....		98
&S Set DSR signal.....		96
&T Auto-tests.....		98
&V Display configuration.....		99
&W Save configuration.....		97
	+	
+ADC Analog digital converter measurements.....		104
+CACM Accumulated call meter.....		72
+CALA Alarm Management.....		18
+CAMM Accumulated call meter maximum.....		73
+CAOC Advice of charge.....		72
+CBST Bearer Type Selection.....		80
+CCED Cell environment description.....		101
+CCFC Call forwarding.....		66
+CCID Card Identification.....		15
+CCLK Clock Management.....		17
+CCUG Closed User Group.....		78
+CCWA Call waiting.....		68
+CEER Extended error report.....	21, 157	
+CEER, Failure Cause.....		159
+CFUN Set phone functionality.....		16
+CGACT PDP context activate or deactivate.....		146
+CGANS Manual response to network request for PDP context activation.....		154
+CGATT Attach or Detach.....		145
+CGAUTO Automatic response to network request for PDP context activation.....		153
+CGCLASS GPRS Mobile Station Class.....		148
+CGDATA Enter Data State.....		147
+CGDCONT Define PDP Context.....		140
+CGEREP GPRS Event Reporting.....		150
+CGMI Manufacturer identification.....		13
+CGMM Request Model Identification.....		13
+CGMR Request revision identification.....		13
+CGPADDR Show PDP Address.....		155
+CGQMIN Quality of Service Profile Minimum Acceptable		144
+CGQREQ Quality of Service Profile Requested.....		142
+CGREG GPRS network registration status.....		151
+CGSMS Select service for MO SMS messages.....		149
+CHLD Call related supplementary services.....		74
+CICB Incoming Call Bearer.....		24
+CIMI Request IMSI.....		15
+CIND Indicator Control.....		106
+CKPD Keypad control.....		17
+CLCC List current calls.....		75
+CLCK Call barring.....		67
+CLCK Facility lock.....		41
+CLIP Calling Line Identification.....		70
+CLIR Calling line identification restriction.....		69
+CME ERROR GPRS-related errors.....		159
+CME Error Result Code.....		161
+CMEC Mobile equipment control mode.....		107
+CMEE Report Mobile Equipment errors.....		17
+CMER Mobile equipment event reporting.....		105
+CMGD Delete message.....		61
+CMGF Preferred Message Format.....		54
+CMGL List message.....		58
+CMGR Read message.....		57
+CMGS Send message.....		59
+CMGW Write Message to Memory.....		59
+CMS ERROR Message service failure result code.....		162
+CMSS Send Message from Storage.....		60
+CMUT Microphone Mute Control.....		26
+CNMA New Message Acknowledgement.....		51
+CNMI New message indication.....		56
+CNUM Subscriber number.....		47
+COLP Connected line identification presentation.....		71
+COPN Read Operator Name.....		37
+COPS Operator Selection.....		31
+CPAS Phone activity status.....		16
+CPBF Find phonebook entries.....		44
+CPBN Move action in phonebook.....		46
+CPBP Phonebook phone search.....		46
+CPBR Read phonebook entries.....		44
+CPBS Select phonebook memory storage.....		43
+CPBW Write phonebook entry.....		45
+CPHS CPHS command.....		118
+CPIN Enter PIN.....		38
+CPIN2 Enter PIN2.....		40
+CPINC PIN remaining attempt number.....		40
+CPLS Selection of Preferred PLMN list.....		34
+CPMS Preferred Message Storage.....		53
+CPOF Power off.....		15
+CPOL Preferred operator list.....		35
+CPUC Price per unit and currency table.....		73
+CPWD Change password.....		42
+CPWD Modify SS password.....		68
+CR Service reporting control.....		156
+CR Service Reporting Control.....		81
+CRC Cellular result codes.....		156
+CRC Cellular Result Codes.....		82
+CREG Network Registration.....		33
+CRLP Radio link protocol parameters.....		83
+CSAS Save Settings.....		54
+CSCA Service center address.....		62
+CSCB Select Cell Broadcast Message Types.....		62
+CSCS Select TE character set.....		14
+CSDH Show text mode parameters.....		55
+CSMP Set Text Mode Parameters.....		60
+CSMS Select message service.....		51
+CSNS Single Numbering Scheme.....		24

+CSQ Signal Quality	30	+WMIR Customer storage mirror	122
+CSSN Supplementary Service Notifications	76	+WMSC Message status modification	63
+CSVM Set Voice Mail Number	49	+WMUX Multiplexing Mode	100
+CUSD Unstructured Supplementary Service Data	77	+WNON Network operator name	121
+DOPT Others radio link parameters	83	+WOPEN Open AT control command	124
+DR V42bis data compression report	85	+WOPN Read operator name	34
+DS V42bis data compression	84	+WPCS Phonebook Character Set	14
+ECHO Echo Cancellation	27	+WRIM Ring Indicator Mode	114
+FBOR Page transfer bit order	89	+WRST Reset	125
+FBUF Buffer size report	89	+WSCAN Scan	114
+FCLASS Select Mode	81	+WSST Set standard tone	126
+FCQ Copy quality checking	89	+WSTR Status Request	113
+FCR Capability to receive	89	+WSVG Select Voice Gain	113
+FDCC DCE capabilities parameters	91	+WSVN Write IMEI SVN	127
+FDIS Current sessions parameters	90	+WTONE Play tone	110
+FDR Receive Data	88	+WUSS Unchange SMS Status	65
+FDT Transmit Data	88	+WVMI Unsolicited result voice mail indicator	120
+FET Transmit page punctuation	88	+WVR Voice Rate	112
+FK Terminate Session	89		
+FLID Local ID string	91	3	
+FPHCTO Page transfer timeout parameter	91		
+FPTS Page transfer status parameters	88	32kHz power down mode +W32K	115
+FRH HDLC receive speed	87		
+FRM Receive speed	86	A	
+FRS Receive silence	87	A Answer a call	21
+FTH HDLC transmit speed	86	A/ Repeat last command	15
+FTM Transmit speed	86	Abort command +WAC	110
+FTS Stop transmission and wait	87	Accumulated call meter +CACM	72
+GCAP Capabilities list	15	Accumulated call meter maximum +CAMM	73
+ICF DTE-DCE character framing	94	Advice of charge +CAOC	72
+IFC DTE-DCE local flow control	95	Alarm Management +CALA	18
+ILRR DTE-DCE local rate reporting	82	Alternate line service +WALS	124
+IPR Fixed DTE rate	93	Analog digital converter measurements +ADC	104
+SIDET SideTone modification	29	Answer a call A	21
+SPEAKER Speaker & Microphone selection	26	AT Command Examples	182
+STCR Unsolicited Result SIM ToolKit Control Response ¹³⁷		Automatic answer S0	23
+STGI SIM ToolKit Get Information	134	Automatic dialing with DTR %D	23
+STGR SIM ToolKit Give Response	137	Automatic response to network request for PDP context activation +CGAUTO	153
+STIN SIM ToolKit Indication	133	Auto-tests &T	98
+STSF SIM ToolKit Set Facilities	131	Avoid phonebook initialization +WAIP	48
+VGR, +VGT Gain control	25		
+VIP Initialize Voice Parameters	29	B	
+VTD, +VTS DTMF signals	22	Back to online mode O	96
+W32K 32kHz power down mode	115	Bearer Type Selection +CBST	80
+WAC Abort command	110	Buffer size report +FBUF	89
+WAIP Avoid phonebook initialization	48		
+WALS Alternate line service	124	C	
+WATH Hang-up	127	Call barring +CLCK	67
+WCBM Cell Broadcast Message Identifiers	63	Call forwarding +CCFC	66
+WCCS Custom character set	116	Call related supplementary services +CHLD	74
+WCDM Change default melody	115	Call waiting +CCWA	68
+WCDP Change default player	122	Calling line identification presentation +CLIP	70
+WCPI CPHS information	121	Calling line identification restriction +CLIR	69
+WCSP Customer service profile	122	Capabilities list +GCAP	15
+WDCI Unsolicited result diverted call indicator	120	Capability to receive +FCR	89
+WDCP Delete Calls Phonebook	48	Card Identification +CCID	15
+WDR Data Rate	112	Cell Broadcast Message Identifiers +WCBM	63
+WDTMF Play DTMF tone	111	Cell environment description +CCED	101
+WDWL Downloading	111	Cellular result codes +CRC	82, 156
+WGPRS GPRS Parameters Customization	157	Change default melody +WCDM	115
+WIND General Indications	103	Change default player +WCDP	122
+WIOM Input/Output Management	109	Change password +CPWD	42
+WIOR Read GPIO value	108	Clock Management +CCLK	17
+WIOV Write GPIO value	109	Closed User Group +CCUG	78
+WLCK Lock	117		
+WLPR Read Language Preference	107		
+WLPW Write Language Preference	108		
+WMBN CPHS mail box number	123		
+WMBS Multi-band selection	127		

Command line		Select TE character set +CSCS.....	14
<i>AT</i>	11	Set phone functionality +CFUN	16
Command Type and Next Action Indicator.....	190	Commands, GPRS	
Commands, Call Control		Automatic response to network request for PDP context	
Answer a call <i>A</i>	21	activation +CGAUTO	153
Automatic answer <i>S0</i>	23	Cellular result codes +CRC	156
Automatic dialing with DTR %D.....	23	Define PDP Context +CGDCONT	140
Dial command <i>D</i>	19	Enter Data State +CGDATA.....	147
DTMF signals +VTD, +VTS.....	22	Extended error report +CEER.....	157
Echo Cancellation +ECHO	27	GPRS Attach or Detach +CGATT.....	145
Extended error report +CEER.....	21	GPRS Event Reporting +CGEREP.....	150
Gain control +VGR, +VGT.....	25	GPRS Mobile Station Class +CGCLASS	148
Hang-Up command <i>H</i>	20	GPRS network registration status +CGREG.....	151
Incoming Call Bearer +CICB.....	24	GPRS Parameters Customization +WGPRS.....	157
Initialize Voice Parameters +VIP.....	29	GPRS-related errors +CME ERROR	159
Microphone Mute Control +CMUT.....	26	Manual response to network request for PDP context	
Redial last telephone number <i>DL</i>	22	activation +CGANS	154
SideTone modification +SIDET.....	29	PDP context activate or deactivate +CGACT.....	146
Single Numbering Scheme +CSNS.....	24	Quality of Service Profile Minimum Acceptable +CGQMIN	
Speaker & Microphone selection +SPEAKER.....	26	144
Commands, Data		Quality of Service Profile Requested +CGQREQ	142
Bearer Type Selection +CBST.....	80	Request GPRS IP service <i>D</i>	152
Cellular result codes +CRC.....	82	Select service for MO SMS messages +CGSMS.....	149
DTE-DCE local rate reporting +HLRR.....	82	Service reporting control +CR	156
Others radio link parameters +DOPT.....	83	Show PDP Address +CGPADDR.....	155
Radio link protocol parameters +CRLP	83	Commands, Network Service	
Select data compression %C.....	84	Network Registration +CREG.....	33
Select data error correcting mode \N.....	85	Operator Selection +COPS	31
Select Mode +FCLASS.....	81	Preferred operator list +CPOL	35
Service Reporting Control +CR	81	Read Operator Name +COPN.....	37
V42bis data compression +DS	84	Read operator name +WOPN	34
V42bis data compression report +DR	85	Selection of Preferred PLMN list +CPLS	34
Commands, Fax		Signal Quality +CSQ.....	30
HDLC receive speed +FRH.....	87	Commands, Phonebook	
HDLC transmit speed +FTH.....	86	Avoid phonebook initialization +WAIP	48
Receive silence +FRS.....	87	Delete Calls Phonebook +WDCP	48
Receive speed +FRM.....	86	Find phonebook entries +CPBF.....	44
Stop transmission and wait +FTS.....	87	Move action in phonebook +CPBN.....	46
Transmit speed +FTM.....	86	Phonebook phone search +CPBP.....	46
Commands, Fax Class 2		Read phonebook entries +CPBR.....	44
Buffer size report +FBUF.....	89	Select phonebook memory storage +CPBS	43
Capability to receive +FCR.....	89	Set Voice Mail Number +CSVM.....	49
Copy quality checking +FCQ.....	89	Subscriber number +CNUM.....	47
Current sessions parameters +FDIS	90	Write phonebook entry +CPBW	45
DCE capabilities parameters +FDCC.....	91	Commands, Security	
Local ID string +FLID	91	Change password +CPWD	42
Page transfer bit order +FBOR.....	89	Enter PIN +CPIN	38
Page transfer status parameters +FPTS.....	88	Enter PIN2 +CPIN2.....	40
Page transfer timeout parameter +FPHCTO.....	91	Facility lock +CLCK	41
Receive Data +FDR	88	Pin remaining attempt number +CPINC.....	40
Terminate Session +FK.....	89	Commands, Short Messages	
Transmit Data +FDT	88	Cell Broadcast Message Identifiers +WCBM.....	63
Transmit page punctuation +FET.....	88	Delete message +CMGD	61
Commands, General		List message +CMGL.....	58
Alarm Management +CALA.....	18	Message overwriting +WMGO.....	64
Capabilities list +GCAP.....	15	Message status modification +WMSC.....	63
Card Identification +CCID.....	15	New Message Acknowledgement +CNMA.....	51
Clock Management +CCLK.....	17	New message indication +CNMI.....	56
Keypad control +CKPD.....	17	Preferred Message Format +CMGF.....	54
Manufacturer Identification +CGMI	13	<i>Preferred Message Storage</i> +CPMS.....	53
Phone activity status +CPAS.....	16	Read message +CMGR.....	57
Phonebook Character Set +WPCS	14	Restore settings +CRES.....	55
Power off +CPOF.....	15	Save Settings +CSAS.....	54
Product Serial Number +CGSN	14	Select Cell Broadcast Message Types +CSCB	62
Repeat last command <i>A/</i>	15	Select message service +CSMS	51
Report Mobile Equipment errors +CMEE.....	17	Send message +CMGS	59
Request IMSI +CIMI	15	Send Message From Storage +CMSS.....	60
Request Model Identification +CGMM	13	Service center address +CSCA	62
Request revision identification +CGMR.....	13	Set Text Mode Parameters +CSMP	60

Show text mode parameters +CSDH.....	55	Commands, V24-V25	
Unchange SMS Status +WUSS.....	65	Auto-tests &T.....	98
Write Message to Memory +CMGW.....	59	Back to online mode O.....	96
Commands, SIM ToolKit		DCE response format V.....	97
SIM ToolKit Get Information +STGI.....	134	Default configuration Z.....	97
SIM ToolKit Give Response (+STGR).....	137	Display configuration &V.....	99
SIM ToolKit Indication +STIN.....	133	DTE-DCE character framing +ICF.....	94
SIM ToolKit Set Facilities +STSF.....	131	DTE-DCE local flow control +IFC.....	95
Unsolicited Result SIM ToolKit Control Response +STCR.....	137	Echo E.....	98
Commands, Specific		Fixed DTE rate +IPR.....	93
+WRST.....	125	Multiplexing Mode +WMUX.....	100
32kHz power down mode +W32K.....	115	Request identification information I.....	99
Abort command +WAC.....	110	Restore factory settings &F.....	98
Alternate line service +WALS.....	124	Result code suppression Q.....	97
Analog digital converter measurements +ADC.....	104	Save configuration &W.....	97
Cell environment description +CCED.....	101	Set DCD signal &C.....	95
Change default melody +WCDM.....	115	Set DSR signal &S.....	96
Change default player +WCDP.....	122	Set DTR signal &D.....	96
CPHS command +CPHS.....	118	Connected line identification presentation +COLP.....	71
CPHS information +WCPI.....	121	Copy quality checking +FCQ.....	89
CPHS mail box number +WMBN.....	123	CPHS command +CPHS.....	118
Custom character set +WCCS.....	116	CPHS information +WCPI.....	121
Customer service profile +WCSP.....	122	CPHS Information Field.....	179
Customer storage mirror +WMIR.....	122	CPHS mail box number +WMBN.....	123
Data Rate +WDR.....	112	CRES Restore settings.....	55
Downloading +WDWL.....	111	Current sessions parameters +FDIS.....	90
General Indications +WIND.....	103	Custom character set +WCCS.....	116
Hang-up +WATH.....	127	Customer service profile +WCSP.....	122
Indicator Control +CIND.....	106	Customer storage mirror +WMIR.....	122
Input/Output Management +WIOM.....	109		
Lock +WLCK.....	117	D	
Mobile equipment control mode +CMEC.....	107	D Dial command.....	19
Mobile equipment event reporting +CMER.....	105	D Request GPRS IP service.....	152
Multi-band selection +WMB5.....	127	Data Commands and Multiplexing.....	178
Network operator name +WNON.....	121	Data packets.....	178
Open AT control command +WOPEN.....	124	Data Rate +WDR.....	112
Play DTMF tone +WDTMF.....	111	DCE capabilities parameters +FDCC.....	91
Play tone +WTONE.....	110	DCE response format V.....	97
Read GPIO value +WIOR.....	108	Default configuration Z.....	97
Read Language Preference +WLPR.....	107	Define PDP Context +CGDCONT.....	140
Ring Indicator Mode +WRIM.....	114	Delete Calls Phonebook +WDCP.....	48
Scan +WSCAN.....	114	Delete message +CMGD.....	61
Select Voice Gain +WSVG.....	113	Dial command D.....	19
Set standard tone +WSST.....	126	Display configuration &V.....	99
Status Request +WSTR.....	113	DL Redial last telephone number.....	22
Unsolicited result diverted call indicator +WDCI.....	120	Downloading +WDWL.....	111
Unsolicited result voice mail indicator +WVMI.....	120	DTE-DCE character framing +ICF.....	94
Voice Rate +WVR.....	112	DTE-DCE local flow control +IFC.....	95
Write GPIO value +WIOW.....	109	DTE-DCE local rate reporting +ILRR.....	82
Write IMEI SVN +WSVN.....	127	DTMF signals +VTD, +VTS.....	22
Write Language Preference +WLPW.....	108		
Commands, Supplementary Services		E	
Accumulated call meter +CACM.....	72	E Echo.....	98
Accumulated call meter maximum +CAMP.....	73	Echo E.....	98
Advice of charge +CAOC.....	72	Echo Cancellation +ECHO.....	27
Call barring +CLCK.....	67	Enter Data State +CGDATA.....	147
Call forwarding +CCFC.....	66	Enter PIN +CPIN.....	38
Call related supplementary services +CHLD.....	74	Enter PIN2 +CPIN2.....	40
Call waiting +CCWA.....	68	Extended error report +CEER.....	21, 157
Calling line identification presentation +CLIP.....	70		
Calling line identification restriction +CLIR.....	69	F	
Closed User Group +CCUG.....	78	Facility lock +CLCK.....	41
Connected line identification presentation +COLP.....	71	Failure cause.....	163
List current calls +CLCC.....	75	Failure cause for +CEER.....	159
Modify SS password +CPWD.....	68	Fax application setup.....	87
Price per unit and currency table +CPUC.....	73		
Supplementary Service Notifications +CSSN.....	76		
Unstructured Supplementary Service Data +CUSD.....	77		

Fax Class 2 indication messages.....	92
Find phonebook entries +CPBF.....	44
Fixed DTE rate +IPR.....	93

G

Gain control +VGR, +VGT.....	25
General Indications +WIND.....	103
GPRS AT command examples.....	158
GPRS Attach or Detach +CGATT.....	145
GPRS Event Reporting +CGEREP.....	150
GPRS Mobile Station Class +CGCLASS.....	148
GPRS network registration status +CGREG.....	151
GPRS Parameters Customization +WGPRS.....	157
GPRS-related errors +CME ERROR.....	159
GSM call barring sequences list.....	169
GSM call forwarding sequences list.....	168
GSM call waiting sequences list.....	169
GSM number presentation sequences list.....	169
GSM security sequences list.....	168
GSM sequences list.....	168

H

H Hang-Up command.....	20
Hang-up +WATH.....	127
Hang-Up command H.....	20
HDLC receive speed +FRH.....	87
HDLC transmit speed +FTH.....	86

I

I Request identification information.....	99
Incoming Call Bearer +CICB.....	24
Indicator Control +CIND.....	106
Information responses, result codes.....	11
Initialization.....	12
Initialize Voice Parameters +VIP.....	29
Input/Output Management +WIOM.....	109

K

Keypad control +CKPD.....	17
---------------------------	----

L

Line settings.....	11
List current calls +CLCC.....	75
List message +CMGL.....	58
Local ID string +FLID.....	91
Lock +WLCK.....	117

M

Manual response to network request for PDP context activation +CGANS.....	154
Manufacturer identification +CGMI.....	13
ME SIM ToolKit Support.....	186
Message overwriting +WMGO.....	64
Message status modification +WMSC.....	63
Microphone Mute Control +CMUT.....	26
Mobile equipment control mode +CMEC.....	107
Mobile equipment event reporting +CMER.....	105
Modify SS password +CPWD.....	68
Move action in phonebook +CPBN.....	46
Multi-band selection +WMBS.....	127
Multiplexing mode +WMUX.....	100

N

N Select data error correcting mode.....	85
Network operator name +WNON.....	121
Network Registration +CREG.....	33
Network requested PDP context activation.....	152
New Message Acknowledgement +CNMA.....	51
New message indication +CNMI.....	56

O

O Back to online mode.....	96
Open AT control command +WOPEN.....	124
Operator names.....	170
Operator Selection +COPS.....	31
Other radio link parameters +DOPT.....	83

P

Page transfer bit order +FBOR.....	89
Page transfer status parameters +FPTS.....	88
Page transfer timeout parameter +FPHCTO.....	91
Parameters storage.....	166
PDP Context Activate or Deactivate +CGACT.....	146
Phone activity status +CPAS.....	16
Phonebook Character Set +WPCS.....	14
Phonebook phone search +CPBP.....	46
PIN remaining attempt number +CPINC.....	40
Play DTMF tone +WDTMF.....	111
Play tone +WTONE.....	110
Power down control via RS232.....	192
Power off +CPOF.....	15
Preferred Message Format +CMGF.....	54
Preferred Message Storage +CPMS.....	53
Preferred operator list +CPOL.....	35
Price per unit and currency table +CPUC.....	73
Product Serial Number +CGSN.....	14

Q

Q Result code suppression.....	97
Quality of Service Profile Minimum Acceptable +CGQMIN.....	144
Quality of Service Profile Requested +CGQREQ.....	142

R

Radio link protocol parameters +CRLP.....	83
Read GPIO value +WIOR.....	108
Read Language Preference +WLPR.....	107
Read message +CMGR.....	57
Read Operator Name +COPN.....	37
Read operator name +WOPN.....	34
Read phonebook entries +CPBR.....	44
Receive Data +FDR.....	88
Receive silence +FRS.....	87
Receive speed +FRM.....	86
Redial last telephone number DL.....	22
Remote disconnection.....	21
Repeat last command A/.....	15
Report Mobile Equipment errors +CMEE.....	17
Request GPRS IP service D.....	152
Request identification information I.....	99
Request IMSI +CIMI.....	15
Request Model Identification +CGMM.....	13
Request revision identification +CGMR.....	13
Reset +WRST.....	125
Restore factory settings &F.....	98

Restore settings +CRES.....	55
Result code suppression Q.....	97
Result codes	
unsolicited.....	165
Result codes final.....	165
Result codes intermediate.....	165
Ring Indicator Mode +WRIM.....	114

S

S0 Automatic answer.....	23
Save configuration &W.....	97
Save Settings +CSAS.....	54
Scan +WSCAN.....	114
Select Cell Broadcast Message Types +CSCB.....	62
Select data compression %C.....	84
Select data error correcting mode \N.....	85
Select message service +CSMS.....	51
Select Mode +FCLASS.....	81
Select phonebook memory storage +CPBS.....	43
Select service for MO SMS messages +CGSMS.....	149
Select TE character set +CSCS.....	14
Select Voice Gain +WSVG.....	113
Selection of Preferred PLMN list +CPLS.....	34
Send message +CMGS.....	59
Send Message from Storage +CMSS.....	60
Service center address +CSCA.....	62
Service reporting control +CR.....	156
Service Reporting Control +CR.....	81
Set DCD signal &C.....	95
Set DSR signal &S.....	96
Set DTR signal &D.....	96
Set phone functionality +CFUN.....	16
Set standard tone +WSST.....	126
Set Text Mode Parameters +CSMP.....	60
Set Voice Mail Number +CSVM.....	49
Short Messages Commands Parameters definition.....	50
Show PDP Address +CGPADDR.....	155
Show text mode parameters +CSDH.....	55
SideTone modification +SIDET.....	29
Signal Quality +CSQ.....	30
SIM Application ToolKit Overview.....	128
SIM Card Insertion and Removal.....	12
SIM Conditions	
Class 2 Commands.....	195
Data commands.....	195
Fax commands.....	195
General commands.....	193
Specific AT commands.....	196
V24-V25 commands.....	195
SIM conditions for command execution and dependence.....	193

SIM for UCS2, coding of alpha fields.....	191
SIM Toolkit Error codes.....	132
SIM ToolKit Get Information +STGI.....	134
SIM ToolKit Give Response +STGR.....	137
SIM ToolKit Indication +STIN.....	133
SIM ToolKit Set Facilities +STSF.....	131
Single Numbering Scheme +CSNS.....	24
Speaker & Microphone selection +SPEAKER.....	26
Specific error result codes.....	162
Status Request +WSTR.....	113
Stop transmission and wait +FTS.....	87
Structure of Terminal Profile.....	188
Subscriber number +CNUM.....	47
Supplementary Service Notifications +CSSN.....	76

T

Terminate Session +FK.....	89
Transmit Data +FDT.....	88
Transmit page punctuation +FET.....	88
Transmit speed +FTM.....	86

U

Unchange SMS Status +WUSS.....	65
Unsolicited result diverted call indicator +WDCI.....	120
Unsolicited Result SIM ToolKit Control Response +STCR.....	137
Unsolicited result voice mail indicator +WVMI.....	120
Unstructured Supplementary Service Data +CUSD.....	77
Using commands during data connection.....	79

V

V DCE response format.....	97
V42bis data compression +DS.....	84
V42bis data compression report +DR.....	85
Voice Rate +WVR.....	112

W

Write GPIO value +WIOW.....	109
Write IMEI SVN +WSVN.....	127
Write Language Preference +WLPW.....	108
Write Message to Memory +CMGW.....	59
Write phonebook entry +CPBW.....	45

Z

Z Default configuration.....	97
------------------------------	----