



# IPN in salmonids a review

October 2003



**The report is supported by:**

The Fisheriers and Aquaculture Industries Research Fund (FHF)  
The Norwegian Research Council (NFR)

## **IPN knowledge**

The IPN virus has a history as one of the most important loss factors in salmonid aquaculture. Also new, marine species experience substantial loss due to IPN when raised in fish farms.

No other fish pathogenic virus has been more extensively examined, yet it is still an unsolved problem for the industry. As an attempt to speed up and focus future research and disease prevention in the industry, FHL havbruk (Norwegian Seafood Federation – aquaculture division) made an initiative during the autumn 2002 to establish a coordinated project to map existing knowledge. The project was mainly financed from the Fisheries and Aquaculture Industries Research Fund (90%) and from the Norwegian Research Council. The project was split into two main parts:

- 1) A thorough scientific review of recent publication on the subject
- 2) A field experience survey

FHL havbruk has been the leading part of the total project in close cooperation with VESO. The steering committee for the project has been constituted with the following people:

Morten Lund – FHL havbruk  
Kjell Maroni – FHL havbruk  
Kristin Thorud – Norwegian Animal Health Authority  
Rune Knutzen – Norwegian Animal Health Authority  
Øystein Evensen – Norwegian School of Veterinary Science

Bård Skjelstad from VESO has been engaged as project coordinator.

This report covers the scientific review of recent research. Scientists with special competence on their area has contributed:

- Espen Rimstad – Norwegian School of Veterinary Science, Oslo
- Edgar Brun – National Veterinary Institute, Oslo
- Ingvill Jensen – Fiskeriforskning, Tromsø
- Lill-Heidi Johansen – Fiskeriforskning, Tromsø
- Alison Gregory, Rob Raynard, Ron Stagg – Fisheries Research Services, Aberdeen
- Paul Midtlyng – VESO, Oslo

A special thank is given to professor Øystein Evensen for his heavy contribution during planning and accomplishment of this review. Thanks also to Asbjørn Husby (National Veterinary Institute, Trondheim) for writing Annex 2.

Trondheim 29/10 2003

Kjell Maroni  
R&D director  
FHL havbruk

## Introduction

The intention of this review is to reveal the state of the art of knowledge about most aspects of the IPN-problem. Special emphasis has been put on links with the particular Norwegian IPN problems in Atlantic salmon. This has influenced the outline of the document and is the reason why for instance pathology of IPN is not included, while functional feed are.

The document tries to point out gaps in knowledge as well as to establish facts. The questioning of some established "truths" and the promotion of subjective prophecies is to a certain attempt done in hope of initiating a discussion among readers. This might support the intention of the overall project of which this review plays just a minor role: to diminish the IPN problem.

There are areas where published research can be interpreted in different ways, and there will therefore be disagreement about some of the opinions put forward in this review. Some publications may of course have slipped away from the author's attention.

The sources have been databases, mainly ISI-bases and PubMed, and databases for non-journal publications like dissertations as well as abstract collections, proceedings etc, i.e. unpublished material has also been examined to some extent.

Øystein Evensen

Bård Skjelstad

Espen Rimstad

Edgar Brun

Lill-Heidi Johansen

Ron Stagg

Paul Midtlyng

Ingvill Jensen

## Table of contents

<b>Executive summary .....</b>	<b>5</b>
<b>1. Control of IPN.....</b>	<b>10</b>
<b>1.1. Control principles .....</b>	<b>10</b>
1.1.1. Vertical transmission.....	10
1.1.2. Biosecurity.....	10
1.1.3. Vaccination.....	11
1.1.4. Selective breeding.....	11
1.1.5. Husbandry .....	11
<b>1.2. Control regime in Scotland.....</b>	<b>12</b>
1.2.1. Legislative control of IPN in Scotland .....	12
1.2.2. Policy on vaccination .....	13
1.2.3. Escapes .....	13
1.2.4. Distribution of IPNV in Scotland and implications for future control regime .....	13
<b>1.3. Control of IPN in Norway.....</b>	<b>14</b>
1.3.1. Has the control strategy been successful?.....	15
1.3.2. How could research help establish a more efficient strategy against IPN?.....	15
<b>1.4. References.....</b>	<b>16</b>
<b>2. The Infectious pancreatic necrosis virus .....</b>	<b>17</b>
<b>2.1. About the virus.....</b>	<b>17</b>
<b>2.2. When should a virus be called IPNV and when should it not? .....</b>	<b>18</b>
<b>2.3. Classification of aquatic birnaviruses.....</b>	<b>18</b>
2.3.1. Serologic classification – something everybody knows?.....	18
2.3.2. Genetic classification .....	20
2.3.3. Genetic classification and virulence factors .....	23
<b>2.4. Viral proteins .....</b>	<b>23</b>
2.4.1. Segment B encoded protein .....	23
2.4.2. Segment A encoded proteins.....	24
<b>2.5. Replication.....</b>	<b>30</b>
2.5.1. Entry into cells.....	30
2.5.2. Temperature sensitivity .....	30
2.5.3. Uncoating .....	30
2.5.4. Noncoding sequences of segment A and B .....	30
2.5.5. Differences in mRNA synthesis.....	30
<b>2.6. Pathogenesis .....</b>	<b>31</b>
2.6.1. Age and susceptibility.....	31
2.6.2. Organ tropism .....	32
<b>2.7. Detection .....</b>	<b>32</b>
<b>2.8. References.....</b>	<b>34</b>
<b>3. Transmission and reservoirs .....</b>	<b>37</b>
<b>3.1. Vertical Transmission of IPNV .....</b>	<b>37</b>
<b>3.2. Horizontal transmission of IPNV .....</b>	<b>40</b>
<b>3.3. Reservoirs .....</b>	<b>41</b>
3.3.1. Farmed fish.....	41
3.3.2. Wild fish.....	43
3.3.3. Water .....	43

3.3.4.	<i>Sediments</i> .....	45
3.3.5.	<i>Invertebrates</i> .....	45
3.3.6.	<i>Birds</i> .....	46
3.3.7.	<i>Mammals</i> .....	46
<b>3.4.</b>	<b>References</b> .....	<b>47</b>
<b>4.</b>	<b>Epidemiology</b> .....	<b>51</b>
<b>4.1.</b>	<b>Descriptive epidemiology</b> .....	<b>52</b>
4.1.1.	<i>Occurrence of IPN-virus in wild salmon</i> .....	53
4.1.2.	<i>Occurrence of IPN-virus and outbreaks in sea farms</i> .....	53
4.1.3.	<i>Occurrence of IPN-virus and outbreaks in hatcheries</i> .....	54
4.1.4.	<i>Geographical distribution</i> .....	55
4.1.5.	<i>IPNV- caused mortality</i> .....	55
4.1.6.	<i>Impact of vaccination</i> .....	55
<b>4.2.</b>	<b>Analytical epidemiology</b> .....	<b>56</b>
4.2.1.	<i>Risk of introducing virus to hatcheries</i> .....	56
4.2.2.	<i>Risk of IPN-outbreaks in hatcheries</i> .....	57
4.2.3.	<i>Risk of introducing virus to sea sites</i> .....	58
4.2.4.	<i>Risk of IPN-outbreaks in sea sites</i> .....	60
4.2.5.	<i>IPNV and other virus infections</i> .....	62
4.2.6.	<i>Modelling</i> .....	62
4.2.7.	<i>Effects of genetics</i> .....	63
4.2.8.	<i>Future epidemiology</i> .....	63
<b>4.3.</b>	<b>References</b> .....	<b>65</b>
<b>5.</b>	<b>Host-related factors</b> .....	<b>68</b>
<b>5.1.</b>	<b>Persistence</b> .....	<b>68</b>
5.1.1.	<i>How is the persistent IPNV infection established and what are the mechanisms behind persistence?</i> .....	68
5.1.2.	<i>Is an IPN virus carrier condition harmful to Atlantic salmon?</i> .....	71
5.1.3.	<i>References</i> .....	74
<b>5.2.</b>	<b>Antiviral mechanisms in fish</b> .....	<b>77</b>
5.2.1.	<i>Innate immunity</i> .....	77
5.2.2.	<i>Antiviral effects on IPNV</i> .....	78
5.2.3.	<i>Specific immunity to IPNV in salmonids</i> .....	80
5.2.4.	<i>Cell-mediated immunity</i> .....	81
5.2.5.	<i>Immunosuppression</i> .....	81
5.2.6.	<i>References</i> .....	82
<b>6.</b>	<b>Vaccination</b> .....	<b>85</b>
<b>6.1.</b>	<b>Protective effects and parameters of immunity after IPN vaccination</b> .....	<b>86</b>
<b>6.2.</b>	<b>Antibody responses in Atlantic halibut</b> .....	<b>87</b>
<b>6.3.</b>	<b>Effect of IPNV or IPNV antigen on abdominal adhesions in vaccinated salmon</b> .....	<b>88</b>
<b>6.4.</b>	<b>Interpretation of epidemiological data</b> .....	<b>88</b>
<b>6.5.</b>	<b>Clinical studies on vaccine efficacy using experimental or field challenge</b> .....	<b>90</b>
<b>6.6.</b>	<b>Commercial information about IPN vaccines</b> .....	<b>91</b>
<b>6.7.</b>	<b>Further and forthcoming reports on IPN vaccine/vaccination studies</b> .....	<b>92</b>
<b>6.8.</b>	<b>References</b> .....	<b>93</b>
<b>7.</b>	<b>Functional feed</b> .....	<b>96</b>
<b>7.1.</b>	<b>Therapeutic treatment</b> .....	<b>96</b>
<b>7.2.</b>	<b>Preventive treatments by functional feed</b> .....	<b>96</b>
<b>7.3.</b>	<b>Experiments with IPN</b> .....	<b>97</b>

7.4.	Field trials.....	97
7.5.	Is malnutrition a risk factor for IPN? .....	98
7.6.	References.....	99
8.	Current research on IPN .....	100
8.1.	Norwegian research projects .....	100
8.2.	EU funded research projects .....	100
8.3.	IPN research projects in the UK .....	100
8.4.	Tabular overview .....	101
8.4.1.	<i>Norway: NFR/FHF projects with major relevance and focus on IPN</i> .....	101
8.4.2.	<i>NFR/FHF projects with partial or potential relevance for IPN</i> <i>research</i> .....	102
8.4.3.	<i>EU research and development projects with relevance for IPN</i> <i>research</i> .....	103
8.4.4.	<i>UK projects and grants in support of IPN research</i> .....	104
8.5.	Current IPN research in the rest of Europe.....	105
8.6.	Current IPN research in North America .....	105
8.7.	Current IPN research in Chile and other parts of South America.....	106
8.8.	Current IPN research in Asia and Australia .....	106
8.9.	Scrutiny of further research databases and sources of information.....	107
8.10.	Industrial research and development projects of relevance.....	107
8.10.1.	<i>Intervet Norbio AS</i> .....	107
8.10.2.	<i>Alpharma AS</i> .....	107
8.10.3.	<i>Aqua Health Ltd./ScanVacc AS</i> .....	107
8.10.4.	<i>Schering-Plough AH</i> .....	107
8.10.5.	<i>Microtek International Inc</i> .....	108
8.11.	References.....	109
Annex 1	.....	111
	Biosecurity issues to be addressed to reduce the risk from IPN.....	111
Annex 2	.....	113
	IPNV Disinfection.....	113
	References.....	115



## Executive summary

### The virus, the pathogenesis and virus detection

---

Infectious pancreatic necrosis virus (IPNV) is probably the best-studied virus that infects and kills fish. It has classically been shown to be virulent to salmonid fish, Atlantic salmon, rainbow trout, brook trout and brown trout included. IPNV is a birna virus, which comes from the fact that its genome is built up of double stranded RNA (bi-RNA) with two genomic segments (A and B). IPNV belongs to the aquatic birnaviruses, a group of viruses that infects fish and invertebrates in the marine environment. Only aquatic birnaviruses that infect salmonids should be designated IPN virus.

IPNV is a relatively small virus, 60 nm in diameter, of a homogenous size and is without a membrane. The outer circumference of the virus is designated capsid. The capsid is built up of proteins (structural proteins), designated VP2 and VP3 (VP-virus protein). These two structural proteins are coded for by segment A, which also codes for two additional non-structural proteins, namely the protease (VP4) and a protein without a well-defined function, VP5. Segment B encodes for VP1, the RNA dependent RNA polymerase (RdRp).

The importance of the different structural and non-structural proteins in viral pathogenesis has not been fully elucidated. In a closely related birna virus (IBDV – infectious bursal disease virus), molecular virulence determinants have been found. This has been done by showing that alteration of certain amino acids in the VP2 protein will render a virulent isolate completely attenuated and with the ability to induce a protective immune response in chicken. The general concept as regards the virulence of IPNV has been that different isolates do not differ in their ability to infect and kill susceptible individuals. However, this has proven wrong based on studies carried out over the last 2-3 years. Preliminary results are in favour of distinct differences in virulence between field isolates. It has also been possible to postulate that defined amino acid motifs of the VP2 protein can be linked to virulence. Further studies are needed to understand these findings in more detail but they can be of potential value in characterisation of different field isolates of IPNV based on genotyping and virulence classification. The possibility of this being of importance for immunogenicity also needs further scrutiny.

The variation found in the major capsid protein (VP2) can have potential implications for cell entry mechanisms. Today, very little is known about the way that virus gain access to the target cell(s). This is a central point in implementing antiviral strategies, based on stimulating innate or adaptive immune responses (see below).

The traditional method of identifying the virus is by growing it in cell culture and using serotype specific serum to neutralise its growth. Indirect detection of the virus by immunohistochemistry in tissue sections is frequently used in diagnostic laboratories, as are modern molecular methods like RT-PCR. Detection of virus infection can also be obtained under field conditions by use of a well-known agglutination principle. For the future is it foreseeable that molecular methods will be of major importance, not the least with the purpose of carry out genetic profiling of the virus and define its virulence characteristics.

## **Transmission and reservoir**

---

### **Vertical transmission**

Despite IPNV having been known and cultured for so long, there is still no conclusive documentation of vertical transmission of IPNV in Atlantic salmon, though circumstantial evidence is in favour of this being of importance. Future research should focus on documenting vertical transmission in Atlantic salmon, but also include aspects of factors that facilitate (or favour) it to happen, the dose needed for virus to be transmitted and to cause infection in the offspring, and the relative importance of transfer by egg or milt. Other areas of research should include the effect of genetic differences in salmon stocks, the health or immune status of adult fish, variation in virulence of different IPNV strains and possible implication for transfer, and the identification of antiviral activity in eggs. There is also need to obtain a better understanding of the association of IPNV and sperm since it is most likely that virus is internalised in the egg by this route.

### **Horizontal transmission and reservoirs**

The presence of IPNV has been confirmed in a very wide and diverse range of organisms and environments. Still, very little is known about the role of these reservoirs in the horizontal transmission of IPNV, both in freshwater and sea water. Although it appears that carrier fish represent the most significant source of horizontal transmission, the relative importance of all the other potential reservoirs is not known. There is a need to focus on research that will shed light on the release of IPNV from potential reservoirs and the virulent nature of such virus strains. In addition, given the diversity of aquatic birnaviruses, a practical classification system must be developed and the relative risk of each group to salmonids (and other aquaculture species) should be assessed in order to understand the significance of IPNV reservoirs. Currently it seems that carrier fish are the most important source of IPNV in the aquatic environment.

## **Control**

---

The IPN-problem is, as can be understood from what has been mentioned above, complex by nature and with many facets. There are many unanswered questions in terms of reservoir, transmission (vertical and horizontal), infectivity and virulence, carrier fish conditions and factors that facilitate establishment of a carrier state and so on. This makes it difficult to control the disease effectively. Some basic principles apply, and the fundament of the strategy should be built on knowledge and scientific judgement. Important principles of disease control, like elimination of vertical transmission and spread of virus through infected brood stock and persistently infected fingerlings or smolt are considered of major importance for spread of the virus. In Norway, one has not gone through with the total implementation of these principles. Reasons for this are mainly economical and practical – costs connected to extensive test programs are enormous and the benefit uncertain.



## Host-related factors

---

### Persistence

From the literature reviewed it can be concluded that IPN virus persistence is a threat both to the carriers themselves and to other fish populations. A carrier situation with low or non-detectable virus titres does not seem to have a direct negative impact on the host. However, a carrier condition is not stable and titre levels fluctuate with time and are typically increased during periods of stress. This results in shedding of more viruses, with increased risk of infecting virus free fish stocks, and increased risk of recurrence of IPN in the carrier population.

### Innate immunity

In salmonids the type I interferon system (IFN) is the innate immune system characterised in most detail, and some information exists regarding its antiviral function. Recently, important advancements have been made concerning the characterisation and function of this system in Atlantic salmon. IPNV is very sensitive to the antiviral mechanisms induced by the IFN-system and it has been shown that the Atlantic salmon Mx protein is able to inhibit the replication of IPNV. This information should be utilised to clarify whether stimulation of innate immunity can prevent disease outbreaks and if differences in virulence between IPNV isolates can be linked to the virus' ability to resist innate antiviral mechanisms. It is also important to investigate possible exploitation of specific antiviral proteins, which are able to actually inhibit IPNV replication.

### Specific immunity

Very limited information is available regarding specific immunity and IPNV in salmonids and very little progress has been made in this area the last few years. However, from the reviewed literature we can say that IPNV infection, natural or experimental, induces a specific, neutralising antibody response in salmonids as assessed by in vitro methods. The role of these antibodies in eradication of and in mediating protection against IPNV has not been clearly established. It is obvious that not all details are understood, as IPNV is so efficient in establishing a persistent infection in a large portion of the fish that survive the acute stage of infection. Cell-mediated immunity is known, from mammals, to be important in virus infections, however no knowledge exists about the role of cell-mediated immunity in an IPNV infection. To be able to understand the immune response to IPNV it is of major importance to establish methods whereby cell-mediated immunity can be understood in more detail.

## Vaccination

---

Despite the fact that the details of the immune mechanisms are not known in detail, vaccination has been used as a means of disease prevention in Norway for almost 10 years, Chile has just started and UK being likely to follow over the next years. Vaccines have been commercially available since 1995 in the Norwegian market, but there are few studies published documenting the efficacy of these vaccines, that being inactivated or recombinant subunit vaccine. Anecdotal evidence and the general understanding is that no vaccine currently available in the market provides protection towards IPN at a level seen for bacterial vaccines and the field efficacy is in general poorly documented.

The underlying mechanisms of immune induction are in general not well known but there is solid documentation to state that the VP2 protein is of major immunologic importance

for protection. Host responses to the VP2 protein can also explain why there are hyper variable regions found in some regions of this protein, immune evasion mechanisms are likely to be involved. There has been a controversy whether there is glycosylation of VP2 or not but recent studies document this is the case although standard mechanisms of glycosylation have not been found. Glycosylation can be of importance for vaccine efficacy. In general there is need for better understanding of the mechanisms of protective immune responses to IPNV.

## Epidemiology

---

Internationally published epidemiological studies on risk factors, causality and economy are few in numbers. This is in spite of IPN being one of the most serious viral diseases in terms of its impact on Atlantic salmon farming. IPNV is widespread in Norwegian aquaculture production and carrier fish may be found in any farm or sea site, although prevalence in wild fish seems to be low.

The ability of epidemiological studies to reveal risk factors is dependent on a precise unit definition and the precise measuring of variables. The improved diagnostic methods are major achievements in this respect. Risk factor studies have mostly been conducted retrospectively using questionnaires for collecting historic information. The dynamic nature of fish production challenge the reliability of this information and greater focus should be placed on prospective, longitudinal studies.

Available literature regarding occurrence of IPN/IPNV constitute a combination of non-peered reports and a few papers published in international journals. Information on risk factors is dominated by non-reviewed reports, abstracts, and lectures. Only a few publications are found in international journals.

## Functional feed and IPN

---

Experimental studies with special diets are scarce. Those carried out seem to indicate a preventive effect against IPN for  $\beta$ -glucan and nucleotides in combination and nucleotides, vitamins and amino acids combined. There is a need for qualified data about the effect available commercial diets have on IPN and progress in this area might require a more united approach from the fish farmers so that commercial aspects and basic research are separated.

There seem to be a need for more knowledge about general feeding regimes and basic needs as such, as well as specific effect on IPN from non-specific functional feed. Many effects from immunostimulants are documented in vitro or by injection. These results should be extended to field conditions.

Functional feed is widely used, but a survey among fish farmers about IPN-experiences show that only a minority mentions functional feed as a way of reducing mortality from IPN in sea farms and none seem to consider it as a significant single factor in preventing IPN in early stages of production. Although many fish farmers probably have experienced great mortality in fish populations given functional feeds, one should recognize nutritional factors as an important contribution to good fish health and a substantial contribution to viral disease control in salmonid fish farming in the future.

## Current research

---

In Norway, a substantial amount of funding has been provided for carrying out research on IPN and IPNV-related problems over the last 5-6 years, and several projects are still ongoing. There is a need to find a solid balance between research focusing on basic aspects of the virus and the virus-host interaction and combine these with projects focusing on problem-solving and projects offering real promise for improvement in disease control in short- and medium term. There is a distinct need for both and as an example, the recent findings where it has been shown that field isolates come out with different virulence profiles can potentially be used for more efficient disease control measures. Furthermore, there is need to get a better understanding as to how this will affect immune protective mechanisms and virus strains' ability to evade immune responses.

## Identified research needs

---

This review summarizes the current research activities and knowledge related to IPN and IPN virus in the scientific world. It points at knowledge gaps which can serve as a guide for future priorities in IPN research in Norway – the most important ones being:

- there is need for a better understanding of virus characteristics governing the ability of the virus to infect and kill the host
- there is need for a better understanding of possibilities and mechanisms of vertical and horizontal transmission and about reservoirs of the virus in freshwater and sea water
- there is need for a better understanding of mechanisms that govern the establishment of a persistent infection and factors that influence its recurrence
- there is a need to understand the early responses to IPNV infection at the cellular level and the host level
- there is need to create a basis for development of efficacious vaccines against IPN
- there is a need to develop tools by which external factors that increase (or reduce) risk of IPN outbreaks can be identified and quantified
- there is a need to understand better the importance of feed and feed components for preventing disease outbreaks
- and there is a need to translate the new information into sound, practical and economical feasible practices of disease control, at the farm level, the regional level and the national level

## 1. Control of IPN

This chapter presents the present strategy of control of IPN in Scotland and Norway. General principles for different control strategies are also addressed and some background information about previous and ongoing discussion about control strategy is commented.



### 1.1. Control principles

#### 1.1.1. Vertical transmission

Although vertical transmission has not been conclusively demonstrated in Atlantic salmon there is sufficient evidence from other salmonid species to indicate that vertical transmission is a strategy utilised by IPNV and a route that should be controlled (*see also 3.1.*). Measures to reduce risk will include:

- only using parents from broodstock populations tested for IPNV and demonstrated to be negative.
- in positive populations testing individual broodstock and only using eggs from parental pairs testing negative.
- egg disinfection immediately post fertilisation and again at pre-hatch.

#### 1.1.2. Biosecurity

Biosecurity is central to reducing the risk of disease outbreaks and controlling the transmission of diseases such as IPN. In the context of this review biosecurity is the application of risk reduction procedures designed to prevent pathogens (IPNV) entering or leaving a farm where fish have been, or are present, so as to reduce or eliminate the spread of IPNV. It involves a number of risk reduction activities designed to prevent the spread of disease and is applicable to farms that are confirmed infected to stop the spread of infection and also to non-infected farms as a precautionary measure.

It is likely that farmed fish are the most important reservoir of IPNV and that carriers are capable of shedding sufficient virus to establish an infection in exposed populations (*5.1.2.5.*). Transfers of farmed fish between farms are therefore one of the highest risks in the transmission of IPN and one of the most effective ways of introducing IPN into a farm. It therefore follows that a risk assessment should be conducted before any movement of live fish takes place onto a farm. This practice is generally recommended in Scotland and it is required in certain situations (*1.2.1*). In Norway, a general health certificate must follow all movements of fish. Movement of parr is quite common between hatcheries. There is a general prohibition of moving fish in sea. Risk assessments are voluntary.

In some cases in countries or zones that are largely free of certain serious fish diseases there may also be a requirement to remove the source of infection and cull fish populations confirmed to be infected. This eradication policy applies to IPN in some countries where IPN is rare or absent e.g. Sweden.

Biosecurity issues to be addressed to reduce the risk from IPN are given as an annex at the end of this report.

### 1.1.3. Vaccination

Vaccination offers an important potential option for control of IPN. Today, only injectable vaccines are commercially available. Bath vaccines for protection of fry would represent a major improvement of IPN control ability. Vaccination may offer a tool to reduce the carrier-state and thereby have a beneficial effect on reducing vertical transmission. Some studies have shown that vaccinated post smolts do not become carriers following challenge (e.g. Frost and Ness 1997). However, more work is needed to establish this and it is also noteworthy that some fish do not respond to vaccination.

Currently several vaccines against IPN are being used regularly and some are undergoing field trials in marine sites in Scotland, Norway and Chile. However the efficacy of these vaccines in protecting against mortality in post smolts is still uncertain and the potential of the vaccines to eliminate carriers and reduce virus shedding is unknown (6.1).

The authorities should be aware of the impact they have on the development of medicinal products like vaccines through licensing practice and regulation. Differences between countries in required documentation for new products and inefficient handling of license application would raise development costs and possibly reduce the interest from a commercially orientated medicinal industry. Admittance or prohibition of special techniques and/or contents of vaccines is another example of public impact on future development of medicinal product to the aquaculture industry.

### 1.1.4. Selective breeding

There is now evidence that IPN-resistance may be a family trait (Okamoto *et al.* 1987) and specialist-breeding companies may soon be able to market IPN resistant strains of Atlantic salmon (e.g. Landcatch NS “Good results on IPN-free strain” Fish Farming International April 2003 pp29). If such promises become reality then this may also provide a more general control benefits through reduced infection pressure, reduced numbers of carrier fish and resistance to vertical transmission. An important element of selective breeding is that resistance is conferred on all stages of Atlantic salmon susceptible to disease (i.e. first feeding fry and post smolts) and to all strains of IPNV.

### 1.1.5. Husbandry

Good husbandry is an essential aspect of disease management and control. For a viral disease with no treatment this will involve managing the environment of the fish to minimise stress and reduce the likelihood of transmission. Farmers need to ensure the highest standards of husbandry especially when fish are highly susceptible to disease. Critical time periods with regard to IPN will be:

- prior to and when transferring smolts to sea and in the first few months after seawater transfer
- prior to and during the broodstock stripping season
- at the time of yolk sac absorption and first feeding in fry.

Assuming that moribund and dead fish shed more virus than carrier fish then the prompt removal and safe disposal of mortalities is a simple husbandry measure which can help prevent the spread of disease. Measures will include the daily inspection of tanks and cages for evidence of dead or moribund fish and the use of systems for removing mortalities from fish farm tanks and cages and their safe disposal (e.g. by composting or ensiling).



## 1.2. Control regime in Scotland

IPN is categorised as a List III disease under Annex A of EU Council Directive 91/67 (as amended). List III diseases are present within the EU and are regulated under national control programmes within each Member State. In Great Britain IPN is a notifiable disease under The Diseases of Fish Acts 1937 and 1983. This legislation provides for the registration of fish farms, requirements on the owners of fish farms, including the numbers and the species of fish stocked, the movements of fish to and from fish farms and the escapes of fish from fish farms. It also provides powers for the control of the activities on fish farms in the event that a notifiable disease is known to present or suspected of being present. Currently there are no regulations that control the process of fish farming, from a fish health perspective, if there is no evidence of the presence of notifiable disease. In Scotland these issues are dealt with by voluntary codes of practice enforced, principally, by industry quality assurance schemes. In March 2003 the Scottish Executive published a Strategic Framework for Scottish Aquaculture that places a responsibility on the industry to further develop an industry wide code of practice that includes aspects of the management of disease and the maintenance of good health status.

### 1.2.1. Legislative control of IPN in Scotland

Under the Disease of Fish Acts 1937 and 1983 if there are reasonable grounds for suspecting that any inland or marine waters are infected, or may become infected, with IPN, Scottish Ministers may designate those waters in order to prevent the spread of the disease. A Thirty Day Notice (TDN) or a Designated Area Order (DAO) may be served on any person who is the occupier of inland waters or any person who carries on the business of fish farming in marine waters situated in the designated area.

A TDN is a temporary notice that may be served as a precautionary measure while an investigation is conducted to confirm or rule out the presence of IPN, or any other notifiable disease. A DAO may be made when the presence of IPN has been confirmed and allows the Official Service to:

- prohibit the movement of live fish or eggs, or foodstuff for fish, into or out of a farm, without the permission of the Ministers;
- serve notices requiring the removal of dead and dying fish, and the disposal of such fish by a specified method;

These controls are applied to all fish species other than trout, which have been exempt from official controls for IPN since 1994.

Movement restrictions can be revoked if the site is fallowed, cleaned and disinfected, or if a programme of testing provides good evidence that the site or watercourse is no longer infected. Ministers also have discretion to allow movements of infected live fish or gametes from a site subject to a DAO. The scientific basis for the application of discretion is based on a risk assessment with two major components. Firstly, that the movement does not significantly change the health status of the receiving waters (e.g. if a farm or zone is already infected and subject to a DAO). Secondly, that the farmer can demonstrate that the movement is likely to improve the IPN status of the receiving or donor waters in the longer term. An exception to this rule is the movement of Atlantic salmon brood stock or eggs into freshwater sites. In this latter case brood stock originating from an infected site must be tested for IPNV at time of stripping and fertilised ova from infected parents must be



destroyed. This requirement is the principal control measure to prevent vertical transmission of IPNV in salmon.

### 1.2.2. Policy on vaccination

There are currently no fully licensed vaccines for IPN in Scotland. Animal Test Certificates have been granted for field trials of two trial vaccines. The efficacy of these vaccines is not yet proven but a vaccine is clearly a desirable control measure for preventing epidemics in post smolts.

### 1.2.3. Escapes

Under the Registration of Fish Farming and Shellfish Farming Businesses Amendment (Scotland) Order (2002), fish farmers must notify the Scottish Ministers of any escapes or suspected escapes of farmed fish. In addition, a *Code of Practice on the Containment of Farmed Fish* governs the management of farms to minimise escapes.

### 1.2.4. Distribution of IPNV in Scotland and implications for future control regime

Regular (annual) surveillance indicates that IPNV has a limited distribution in freshwater Atlantic salmon farms. Currently, around 20% freshwater salmon sites are known to be infected although the policy of moving IPN-infected brood fish to freshwater sites means that in reality the percentage of fresh water sites that are temporarily infected in any particular year is inflated. In contrast infection in marine salmon farms is widely distributed with >70% of sites known to be infected. Between 1996-2002 the prevalence of infection has increased, both in freshwater and marine farms. In contrast to farms, surveillance of wild salmonid fish suggests that prevalence of IPNV is not increasing (4.1.1). Between 1993 to present, 5600 fish which were almost all wild Atlantic salmon and brown trout were examined from more than 45 rivers and several marine locations from a wide geographic area of Scotland. IPNV was detected in many locations but with no evidence of clinical disease. During investigations of clinical outbreaks of IPN in a freshwater hatchery infected fish were found downstream of the infected farm (4.2.1). There was no evidence that prevalence was greater in salmon and sea trout from seawater than from freshwater. IPNV prevalence varied between years and appeared to decline over the period. However, this decline was not statistically significant. There was no increase in prevalence of IPNV in wild fish over the period when prevalence in farms greatly increased. The average prevalence of IPNV in the fish tested was 0,55%. But data modelling showed that infected populations of fish were patchily distributed with 6,3% of the populations tested being infected at a prevalence of 10%. Thus it appears that infected wild fish are widely distributed but are relatively rare.

**...surveillance of wild salmonid fish suggests that IPNV is not widespread in wild salmonid fish populations ..... and that IPN may have a greater prevalence in wild salmonids in seawater than in freshwater...**

The future of the control programme in Scotland has been the focus of recent discussion between industry and government (AHJWG IPN sub group report). Although prevalence of IPNV is rising in seawater there is a strong view that the disease is controllable in freshwater and in particular that the controls on vertical transmission should be maintained. Therefore it has been decided to maintain the current regime for the foreseeable future.

### 1.3. Control of IPN in Norway

The official Norwegian control regime has been focused on controlling the disease. The disease IPN is listed as a Group B-disease. This means that the disease is notifiable and that restrictions on movement of fish apply. Detection of IPN virus by culture or any other approved methods does not trigger restrictions for any fish farm (except from the living gene bank of wild Atlantic salmon where carriers are removed). This practice was established in 1984, when detection of virus no longer gave public restriction, yet disease outbreaks should<sup>1</sup>. The arguments were that virus detection was very common without any sign of clinical disease.



When disease has been diagnosed, a current official control regime implements a general restriction against movement of fish. Dispensation can be given, for instance in connection with disease in smolt groups. In these cases the fish are usually allowed to be put to sea because of general welfare aspects.

The strategy against IPN has been thoroughly discussed, both by the Norwegian Animal Health authorities (SDT) and in the industry. In 1995, an official working group presented a proposal to the authorities as to how to control IPN in Norway<sup>2</sup>. The following was proposed as general guidelines:

- Testing of brood stock with rejection of carriers and rejection of brood stock from populations with a history of clinical IPN.
- Restrictions on sale of fry from populations that have experienced an IPN-outbreak.
- Reduction on restrictions in sea farms, since the disease already was handled as a list III (C) disease, although it was (and still is) a list II (B) disease.

These strategies focus both on horizontal and vertical transmission of the virus. The strategy expresses a precautionary attitude based on general principles of disease control, especially towards diseases with possible vertical transmission. SDT did not implement any of these proposals, but the discussion is ongoing and has been since -95.

Several arguments have been raised against obligatory brood fish testing:

- The effect and importance of vertical transmission is uncertain, especially as long as there is little control with horizontal transmission.
- Experiences from brood fish companies were interpreted to indicate that vertical transmission was of minor importance to later occurrence of IPN.
- Test capacity would be a problem and uncertainty of test results would make them useless.

All these arguments are of course balanced against the cost they represent for the industry.

Arguments against restriction on sale of fry from populations that have undergone an IPN-outbreak have been of mercantile and judicial character<sup>3</sup>. The concern of losing the opportunity of proper disease monitoring seem to have been important when discussing whether IPN should be treated as a list II (B) or list III (C) disease. In this case it seems as if bureaucratic and judicial aspects were weighted as more important than scientific significance.

### 1.3.1. Has the control strategy been successful?

The IPN-problem in Norway is often referred to as the biggest health problem in Norwegian aquaculture. There is little doubt that the problem is even bigger than described by public statistics based on diagnosed cases<sup>12</sup>. Norwegian authorities are well aware of the problems caused by IPN in Norwegian aquaculture and the severity of the situation. They have repeatedly spoken for a full evaluation of the strategy against the disease, but the work has been postponed for several years<sup>4,7</sup>. They are also aware of the unfortunate situation caused by unequal handling by regional authorities in different parts of Norway<sup>4,5,7</sup>. Lately, the situation has been described in the following way<sup>9</sup>:

- There are no guidelines for control of IPN that are unequivocally agreed upon
- Several future strategies are possible
- There are no precise advice on how to prevent or deal with the disease
- There is an unfortunate variation in administrative practice between regions

In a survey by VESO (2003), only a minority among both fish health personnel and fish farmers thinks that the IPN-problem would have been more prominent without the administrative management they know<sup>13</sup>. The most common remark when asked to propose suggestions for a future strategy is that brood stock control should have been stricter.

From this one cannot say that the strategy towards IPN in Norway has been an evident success so far. No doubt, the future strategy will be evaluated thoroughly and most likely it



will be adjusted. Eradication of the virus is apparently an unrealistic strategy but a significant reduction of the disease problem in freshwater hatcheries and sea farms has been mentioned as realistic future goal<sup>11</sup>.

### 1.3.2. How could research help establish a more efficient strategy against IPN?

Important principles of disease control, like elimination of vertical transmission and spread of virus through infected brood stock, has not been implemented in the struggle against IPN in Norway. The reasons are mainly economic and practical – costs connected to extensive test programs are big and the benefit is indistinct due to sub optimal test sensitivity. No dramatic cost or extra work will probably be enforced the industry if it is not based upon facts, consensus and obvious winnings.

#### 1.4. References

1. Letter M-73/84 Detection of Infectious pancreatic necrosis Norwegian Ministry of Agriculture 22/5 1984
2. Recommendations from a work group about control of IPN in Norway, June 1995
3. Documents and report from meeting in "Fagforum Fisk", Hell Aug 1996
4. Correspondence between the Regional Veterinary Officer of Troms and Finnmark and the central office of the Norwegian Animal Health authority about administrative practice of IPN 1998 (98-0736.002 Archive 740.32, S-4343/98 archive nr 740.32)
5. Documents and report from meeting in "Fagforum Fisk", Molde Dec 1998
6. Documents and report from meeting in "Fagforum Fisk", Bergen March 1999, issue 9
7. Circular letter from the Regional Veterinary Officer of Moere and Romsdal to local fish health services 18/11 1999
8. Documents and report from meeting in "Fagforum Fisk", Oslo Dec 1999
9. Documents and report from meeting in "Fagforum Fisk", Bergen Sep 2002
10. Letter from Norwegian Animal Health authority 21 Feb 2003 About restrictions when suspicion or detection of contagious disease and visible signs of disease in aquatic animals
11. Thorud: "IPN and public control – how do the Norwegian authorities control IPN today" - summary from meeting in the Aqua veterinarian society, Trondheim Oct 2002
12. Oestvik: "What do we know about the size of the IPN-problem?" - summary from meeting in the Aqua veterinarian society, Trondheim Oct 2002
13. VESO 2003: IPN experiences in the Norwegian fish farming industry (preliminary report)

## 2. The Infectious pancreatic necrosis virus

- Serologic classification has its limitations. Genetic classification seems to be the preferable method for detailed classification of aquatic birnaviruses.
- A detailed genetic classification could give us valuable knowledge about virulence factors, given they are correlated with biological characteristics of the virus. This should be performed on viruses from different outbreaks of IPN and possibly on archive material as well.
- VP1 does not seem to be connected to disease causing properties, but one should keep in mind the comparative studies of IBDV and also the theoretical importance for virus virulence.
- There is a need to ascertain that glycosylation of VP2 is a general trait.
- There is need for an established reverse genetics system for IPNV in Norway. This should preferably be based on other systems than the existing cRNA transfection system normally used for IPNV.
- Basic research should be carried out on VP3, VP4 and VP5. Knowledge about roles connected to protection, persistence and virulence are examples of properties still left to answer properly.
- There is a lack of knowledge of both the entry and expression pattern of IPNV, but the practical utilization of such research is unlikely to be straightforward. Knowledge as to whether age-dependent protection is innate or acquired should be obtained.
- There are many levels of detection of the infection or the agent. Future methods should preferably be able to pinpoint specific viral properties, such as virulence factors.

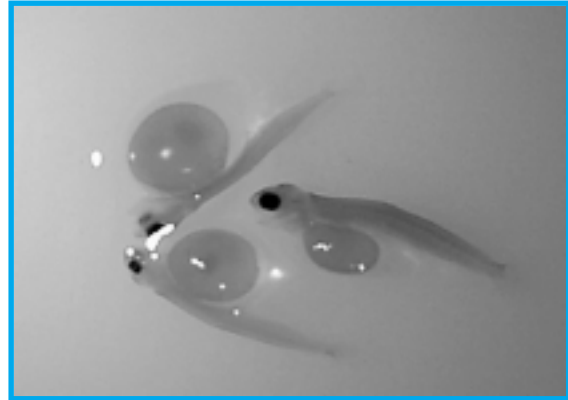

### 2.1. About the virus

There is an intimate relationship between a virus and its host. The description of this relationship is usually denoted pathogenesis. A meaningful discussion of this interaction requires detailed knowledge of the actors, i.e. the virus and the host. Related to size, much more is known about the virus than the host.

IPNV is the type species of the genus Aquabirnavirus of the *Birnaviridae* virus family. The International Committee on Taxonomy of Viruses (ICTV) has taken on the task of categorizing viruses. According to the ICTV descriptions birnaviruses have a bi-segmented, (called segment A and B), double-stranded RNA genome, which are contained within a medium-sized, non-enveloped, single-shelled, icosahedral capsid. The larger of

the two genome segments, segment A (3.1 kb), encodes a polyprotein which is cotranslationally cleaved by the viral protease to generate the major capsid polypeptides VP2 and VP3<sup>19</sup>. The order of the virus proteins in the IPNV polyproteins is: NH<sub>2</sub>-pVP2-NS protease/VP4-VP3-COOH. The NS protease/VP4 is from now on called VP4. VP is an abbreviation for the term “virus protein” and the number denotes the size, i.e. VP1 is the largest virus protein. Genome segment A contains an additional small open reading frame (ORF), which overlaps the amino terminal end of the polyprotein ORF and is in a different reading frame; this small ORF encodes a 17-kDa (or slightly smaller) polypeptide called VP5. The product of genome segment B (2.8 kb) is polypeptide VP1 (94 kDa), the virion associated RNA-dependent RNA polymerase (RdRp)<sup>18</sup>.

The disease IPN was described already in 1941 and the first IPNV was isolated in 1957 in US from brook trout (*Salvelinus fontinalis*)<sup>69</sup>. This isolate was deposited to the American Tissue Culture Collection (ATCC) and then given the reference number VR299. This has later been one of the most studied strains of IPNV. Today it is accepted that IPNV and related viruses have a worldwide distribution and that they cause disease in different aquatic species.

## 2.2. When should a virus be called IPNV and when should it not?

There has been inconsistency in the literature in the use of the term “IPNV”.

The name “infectious pancreatic necrosis virus” describes the disease this virus produces in susceptible salmonids. However, viruses behaving similarly to IPNV in cell cultures have

...“IPNV” should be used only about virus for salmonids...otherwise: “aquatic birnavirus”...

been isolated from non-salmonid fish species with disease patterns different from IPN, and related viruses have also been isolated from aquatic organisms like bivalves. What are these viruses to be called? Some have used “IPNV” irrespectively of the host, but others have

used the term “IPNV-like”, while others again have used the term “aquatic birnavirus” when the origin has been non-salmonids. However, some of these isolates with non-salmonid origin have been used in challenge experiments of salmonid fry and then found to produce IPN. Should all birnaviruses with aquatic origin then be called IPNV? This is obviously incorrect, for instance isolates from the fish blotched snakehead (*Channa lucius*), are genetically slightly more related to the avian infectious bursal disease virus (IBDV) than to the original salmonid IPNV isolates<sup>12</sup>. It is therefore more or less consensus to use the term “IPNV” when the virus is isolated from a salmonid or has been shown to be able to produce IPN in salmonids through challenge experiments. Otherwise the term aquatic birnaviruses or aquabirnavirus is used. This is reflected by ICTV, which use the genus Aquabirnavirus. An isolate from turbot from Norwegian aquaculture would according to this then be an “aquatic birnavirus”. This may seem cumbersome, but then at least the term “IPNV” would be uniform. It may be that the existence of a wide range of hosts for this virus is the reason for the large number of strains described.

## 2.3. Classification of aquatic birnaviruses

### 2.3.1. Serologic classification – something everybody knows?

*Serologic classification has its limitations. Classification of “new isolates” using neutralization test against the 9 characterized serotypes and then calculation of the relationship to existing types is too cumbersome, and are actually not used regularly for description of new isolates. For instance, a large study classifying 231 isolates from Galicia (Northern Spain) ended up with 30% non-typable isolates<sup>11</sup>. The use of MAbs to classify aquatic birnavirus is also limited because of the limited number of available MAbs*



being serotype specific. There are furthermore no studies linking serologic classification pattern to specific properties of the virus apart from the original description of Sp being more virulent for rainbow trout than Ab is.

Why bother with detailed classification of this virus? This may have implications when making a detailed diagnosis of the infection. Originally a birnavirus was called IPNV if it was neutralized, i.e. removal of infectivity of the virus in a cell culture system, when using rabbit antiserum produced against the VR299 strain. It has been shown that neutralizing antibodies primarily reacts with epitopes on the external surface of the VP2.



However, it soon became evident that several viruses isolated from IPN diseased fish could not, or only weakly be neutralized by the anti-VR299 serum. For instance, some European isolates from the 1960-ies could be partly neutralized by anti-VR299 serum, for instance the Sp and the Ab strains, respectively, both isolated in Denmark from rainbow trout with Sp being more prevalent and virulent than Ab<sup>37, 68</sup>. Similarly, isolation of viruses in Japan were found to be unlike VR299<sup>58</sup>. Later work, in which standardized procedures for antiserum production and reciprocal cross neutralization were used, i.e. testing each virus with antisera against each of the other serotypes, concluded that the VR299, Sp and Ab reference strains were “sufficiently” distinct from each other in neutralization tests to be called different serotypes<sup>65</sup>. However, that work also showed that an “IPNV-like” isolate from the bivalve *Tellina tenuis* had no antigenic relationship to the three antigenic serotypes VR299, Sp and Ab. Further studies of the serologic characterization of aquatic birnavirus isolates included marine isolates from Japan. These isolates were closely serologically related to each other, but different studies gave different results regarding serologic relationship to the “standard” strains VR299, Sp and Ab. It is apparent that the attempts to use different polyclonal sera to divide aquatic birnavirus into different antigenic types are rather confusing. Not least because of significant discrepancies between results from different labs. There are several reasons for this a) different methods for antiserum production have been used; b) influence of the number of defective interfering (DI) virus particles varies between virus preparations, i.e. the more DI particles the more antibodies are removed by binding to these defective particles and not to the infectious ones; c) different storage of virus preparations used in the neutralizations tests; d) the possible occurrence of different strains within the same “virus isolate”. One has tried to standardize the IPNV serotyping by setting up strict rules for antiserum production (amount of antigen used when immunizing the rabbits, standardized rabbit breeds etc), standardized neutralization test procedures (i.e. cell type including time after last trypsination, incubation conditions, dilutions, plaque reduction etc), degree of antigenic relatedness (intricate calculation method based on reciprocal neutralization tests)<sup>28</sup>. Following these rules Hill and Way tested 196 virus isolates<sup>28</sup>. Partly as a consequence of this work, it became evident that the original VR299 strain was not a good choice as a model serotype; because viruses anticipated to be closely related to this strain did not behave that way in the standardized neutralization test. This strain was therefore replaced with “West Buxton”, which was related to VR299 and was easier to compare with in the neutralization test. Using their standardized method Hill and Way ended up with 2 “serogroups” (A and B) of aquatic birnaviruses with no cross reaction, and 9 “serotypes” in serogroup A and one in B. These serogroup A serotypes are proposed to be called A1 to A9, but are better known as West Buxton, Sp, Ab, He, Te, Can 1, Can 2, Can 3 and Jasper. However, there are antigenic cross-reactions between the viruses in serogroup A, and the criteria for each of these 9 serotypes being a serotype is more or less suggestions based on

calculations of results in neutralization tests. The criteria for the use of the term “serotype” for aquatic birnaviruses are therefore different from criteria used for other virus families, i.e. the term “serotype” is not a fixed term in virology. It is also incorrect to use the term “IPNV” for all of serogroup A as for instance the He strain was isolated from pike (*Esox lucius*)<sup>1, 28</sup>. In general, for these 9 cross-reacting serotypes most isolates from USA has belonged to A1, from Europe A2-A5 and from Canada A6-A9, from Asia and South-America A1-A3 have been found.

Most IPNV isolates from Norway as well as aquatic birnaviruses from marine species in Norway belong to the Sp serotype (A2).

There are several works in which MAb have been used to classify IPNV and aquatic birnaviruses<sup>8, 10, 47, 64</sup>. The MAbs used in these studies have been produced against a limited numbers of the serotypes. Although some MAbs may neutralize the virus infectivity, the general usage of MAbs in classification of aquatic birnaviruses has been by immunoblotting or ELISA, i.e. medium from an aquatic birnavirus infected cell culture has been spotted on a membrane or plastic well and then MAbs have been added, hence different functions of the antibodies in the polyclonal serotyping (neutralization of virus infectivity) and MAbs typing have been used (antibody binding). It should be expected that the use of MAbs would give a further subdivision within the serotypes. Although the serotype classification that was found with rabbit sera has partly been confirmed indirectly by the use of MAbs, there are several MAb-using studies which could not distinguish all nine serotypes<sup>8, 24, 64</sup>. To summarize, MAbs for each of the different serotypes have not been developed in such a way that a single or a limited number of MAbs can in a unique way recognize only one serotype.

### 2.3.2. Genetic classification

*Gene sequencing are performed by many labs working with fish viruses or is a service that are easily available commercially. Phylogenetic analyses are run by standardized computer programs, and comparisons of results from different labs are more easy to do and possibly more reliable, than serologic comparisons. Genetic classification has therefore some advantages to serologic classification, and although it is still in its adolescence it seems to be the preferable method to classify aquatic birnaviruses.*

The present limitations regarding serologic classification of aquatic birnaviruses should make genetic classification more attractive. Different methods for genetic classification of aquatic birnaviruses have been used:

- RNA fingerprinting<sup>35</sup> (i. e. partly digestion of viral RNA and then 2D-electrophoresis),
- Electrophoretic migration pattern (i.e. analysis of mobility and separation of genomic segments in polyacrylamide gels)<sup>11</sup>,
- Restriction fragment length polymorphism profiles (PCR amplification of cDNA genomic fragment representing most of the VP2 gene followed by digestion with different restriction enzymes)<sup>40</sup> and
- Nucleotide sequence and deduced amino acid sequences comparisons<sup>2, 25, 27</sup>.

The latter method has gained a general acceptance in virology when classifying and comparing virus isolates.

In general, genes encoding polymerases are among the most conserved of all viral genes and for this reason they have been used extensively for phylogenetic analysis when

elucidating relationship between viruses in a long-term perspective. These genes are not strongly influenced by the selection pressure exerted by the immune response, and therefore may represent conserved genes and gene products. However, if a more detailed relationship is investigated, as in epidemiological studies of ongoing virus epidemics, genes encoding virus proteins exposed to acquired immune response would be chosen. For IPNV and aquatic birnaviruses this would be segment A, and VP2 in particular.

However, if analogies to phylogenetic studies of viruses of other species are undertaken, one must take into consideration influences that possibly differ: longevity of the species, particularities of the immune response of the species, structure of animal production, immunization procedures etc.

The phylogenetic comparison available for aquatic birnaviruses has used short areas of segment A<sup>25</sup> or the entire VP2 encoding segment<sup>27</sup> or in the most extensive study the large ORF of segment A was used for the type virus for each serotype and the VP2 gene for several other isolates were added to the alignment studies<sup>2</sup>. Such studies have revealed a (hyper) variable region in the VP2 gene, but also other variable regions of the large segment A ORF. The deduced amino acid sequences clustered into different genogroups<sup>2</sup>. By this method the 9 serotypes of serogroup A was put into 6 different genogroups, and the authors concluded that there was general correlation between the geographical origin and serological classification with the genotyping<sup>2</sup>. That study was published in 2001, and

...9 serotypes of serogroup A was put into 6 different genogroups... and geographical origin matters...

many aquatic birnavirus sequences have been added to the GenBank in the last two years. By screening the GenBank for aquabirnavirus

segment A sequences requiring that they at least covered the VP2 gene in length, 50 sequences were found. These were run in a gene-comparing program (Vector NTI, InfoMax) and a cladogram was made (Fig. 1). A similar search and comparison for segment B found 14 candidate sequences (Fig. 2). (In short, the length of the horizontal branches in such figures represent genetic differences, the vertical position between the different groups is on the other hand more or less arbitrary). The segment A sequences will then cluster into 7-11 groups, depending on the group definition. For instance marine birnavirus isolate sequences from Korea and Japan which were not available in the Blake study<sup>2</sup>, will make up their own group. It is also worthwhile to mention that the type strain Jasper is present at three groups in the cladogram, i.e. this “type strain” is not uniform, and there exists several variants of it. This is probably caused by: 1) It has never been a uniform isolate or 2) Propagation in different cell culture systems in different labs have selected for different variants.

The segment B sequences, Fig. 2, were divided into 7 different groups, depending on where the borders between groups are set. It is worthwhile noticing that the warm water isolate from blotched snakehead is remarkable different from the rest. It is also worthwhile noticing that some of the Spanish (Galicia) sequences make up a cluster of more or less identical viruses both in segment A and B cladograms. These isolates originate from different species, but from the same geographical area, and thus indicate that it is the same virus that is circulating between different species in this area.

A recent comparison of the RNA polymerase genes of Asian marine birnavirus strains and other birnaviruses found high homology between the Asian marine isolates and approximately 20% and 10 % divergence at the nucleotide and amino acid level, respectively, between the marine isolates and the most divergent IPNV (Sp) that was

tested<sup>71</sup>. This should imply a strong conservation of the amino acid sequence of aquatic birnavirus RdRp. The ten aquabirnavirus strains used in that study clustered into 3 Genogroups<sup>71</sup>.

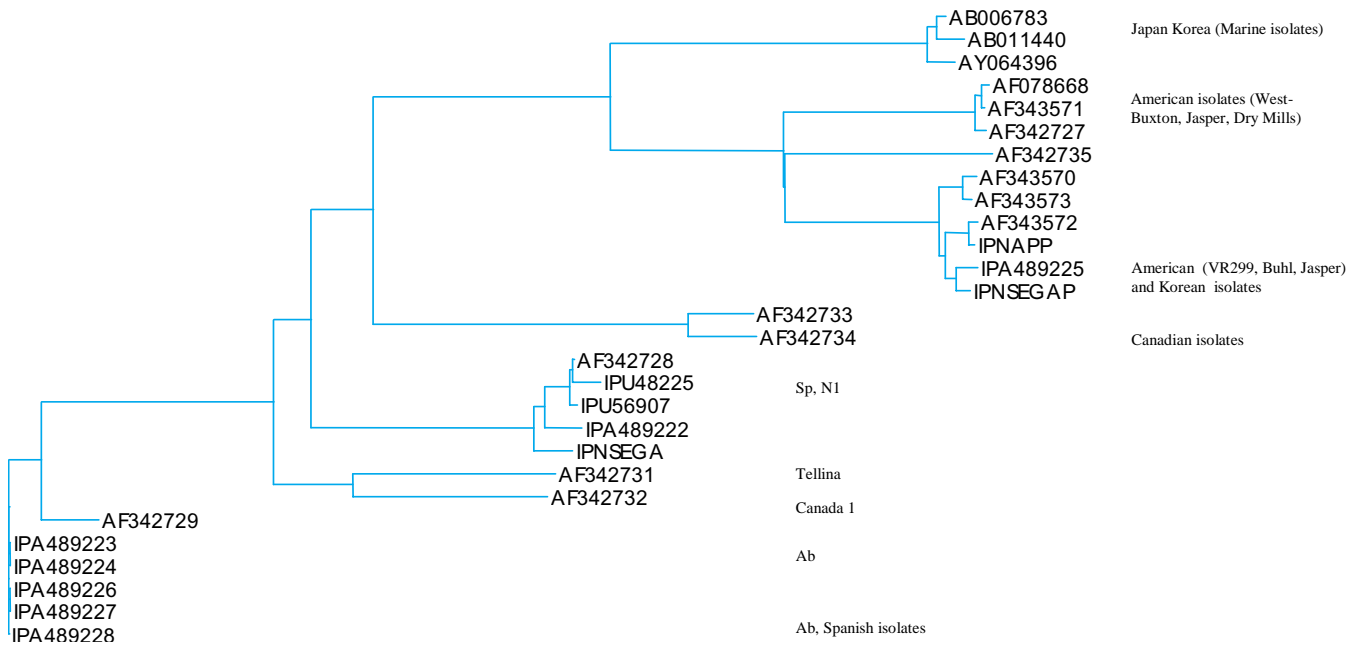

Fig.1 Segment A cladogram based on available sequences in GenBank April 2003

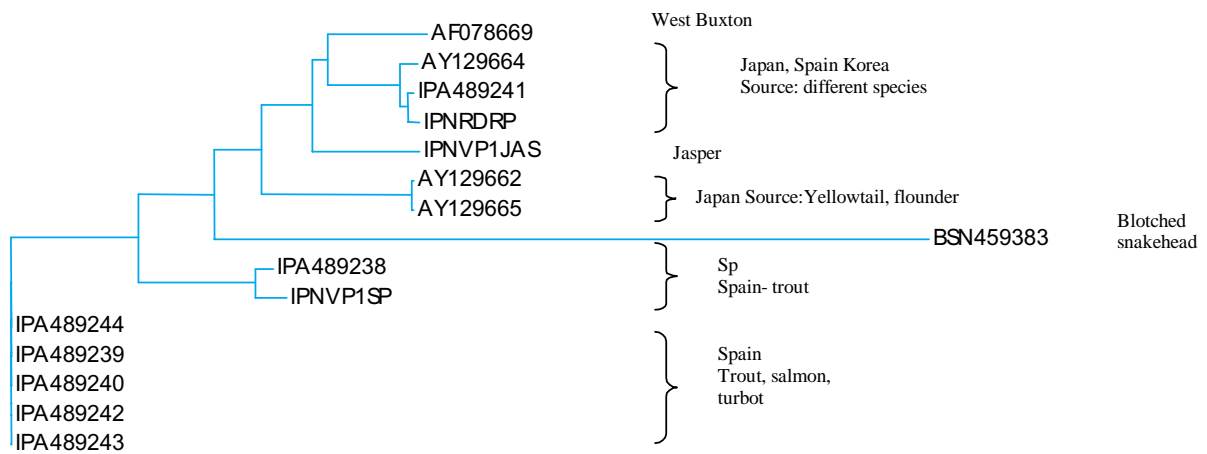

Fig.2 Segment B cladogram based on available sequences in GenBank April 2003

### 2.3.3. Genetic classification and virulence factors

*Comparison of infections between different species should be performed cautiously, but could there be a lesson learned from IBDV for studies of Norwegian IPNV? For IPNV and aquatic birnaviruses in general there is a lack of description of virus properties with influence on the virulence. Many outbreaks of IPN in fry and around smoltification/sea transfer would classify as outbreaks caused by an assumed virulent virus. Are there common genetic traits for these IPN viruses? A systematic detailed genetic classification of IPNV isolated in Norway from different disease outbreaks (and by the possible use of RT-PCR on archival material) with viruses isolated from covert infections could elucidate possible genetic traits behind virus virulence factors. To exclude the possible influence by cell culture selection direct RT-PCR amplification and subsequent sequencing of the amplicons would be preferable.*

Genetic comparison can also be used to elucidate specific virus properties. There are several methods to uncover genetic traits connected to virulence. The ones most frequently used are

- a) sequencing and subsequent alignments,
- b) reverse genetics, in which specific genetic changes of the viral genome are performed and the changes this may give are tested (the technology of *reverse genetics* is elaborated in more detail in the VP2 chapter.)

A comparison to IBDV of chicken may be worthwhile here. For IBDV there are virus strains called “very virulent” (vv) (or sometimes called “highly virulent” (hv)). There are many sequence comparisons performed for vv/hv isolates<sup>9, 34, 45, 56</sup>, and a general conclusion is that the vv/hv seems to group closely together in phylogenetic analyses<sup>9</sup>. This may indicate that these strains are related, which may of course be accounted for by the extensive international trade in commercial poultry farming. However, are there common traits for the vv/hv strains and are these traits related to virulence? Alignment studies of protein sequences across the VP2 hyper variable region found that residues Ile[242], Ile[256] and Ile[294] were highly conserved amongst the IBDV vv strains, and may account for their enhanced virulence<sup>56</sup>. Analysis of the deduced amino acid sequence of VP1 (deduced from segment B sequences) revealed several unique amino acid substitutions in the very virulent strains<sup>36</sup>. In a phylogenetic tree that was made based on amino acid sequence of VP1 the very virulent strains formed a distinct cluster and all other IBDV strains were grouped together. It was suggested that the VP1 of very virulent IBDV is phylogenetically distinct from that of all other IBDV strains and that the vv-IBDV probably originated from an unidentified source<sup>36</sup>.

## 2.4. Viral proteins

### 2.4.1. Segment B encoded protein

#### VP1

*Are the studies of the VP1 of importance for the present IPN situation for Norwegian salmon industry? Studies of segment B and VP1 would be at a very basic level and data coming from these studies may perhaps later show to be of importance for the control of IPN. For instance it may perhaps be that the efficacy of the VP1 enzymatic function is of primary importance for replication rate, which may theoretically be of importance for viral virulence. For instance, the VP1 of the vv/hv variants of IBDV are different from VP1*



of other variants of IBDV (which may of course be accounted for by a different origin and may not be related to the virulence at all.) At present, the VP1 studies of IPNV can be regarded as basic research and direct links to diseases problems in salmonids are not obvious.

The smaller genomic segment B is monocistronic, (i.e. it encodes one protein) and the product is the RNA dependent RNA polymerase (RdRp). Description of this protein as well as much of the initial descriptive work of IPNV and aquatic birnavirus molecular biology has been performed in the labs of Dobos and Leong.

The product of genome segment B was originally found to be a minor internal polypeptide (94 kDa), named VP1, and assumed to be the RdRp. The VP1 is a low copy number viral protein. All RNA viruses, irrespective of replication and coding strategies must encode an RdRp, which carries out multiple functions in the replication process. A similar enzymatic function is not present in eukaryotic cells. The presence of an RdRp was demonstrated in purified IPNV, *i.e.* VP1 is present in infectious virions<sup>14</sup>. Optimum activity of the IPNV RdRp was found at 30 °C, pH 8 and in the presence of 6 mM-magnesium ions<sup>48</sup>. Approximately 50% of the polymerase product remained associated with the dsRNA template of the virions. The latter finding was pursued and it was found that the VP1 is present in the virion in two forms: 1) as a free polypeptide (VP1) and 2) as a genome-linked protein (it is then called VPg), with estimated 1.4 molecules per genomic segment. In the latter form it is linked to the 5'-end of both genome segments by a serine-5'-GMP phosphodiester bond<sup>7</sup>. This bond can be formed experimentally *in vitro* by guanylation of VP1<sup>13</sup>. The birnaviruses is the only dsRNA viruses with a VPg, the size of which is the largest known of the VPgs of RNA viruses. Usually a polymerase needs a primer, *i.e.* a short polynucleotide that acts as a necessary starter for the polymerization to begin. Several viruses have relieved themselves from this primer dependence by making the RdRp act as its own primer. This is the case also for aquatic birnaviruses for which the VPg acts as a primer during RNA transcription<sup>14</sup>. Since VP1 is present in the virion both as a free polypeptide and in a genome-linked form as VPg, this suggested that VP1 might function as a primer during *in vitro* RNA synthesis. Of the two strands of the dsRNA genome, the plus strands (*i.e.* same orientation as mRNA) that are synthesized will remain base-paired to their respective templates<sup>14</sup>.

...VP1 is present in the virion in two forms... birnaviruses is the only dsRNA viruses with a VPg...

The RdRps associated with single-stranded plus RNA viruses have some common characteristic motifs, either as a consequence of a common progenitor or of a congruent development. However, the birnavirus (that is IPNV, IBDV and Drosophila X virus) RdRps lacks the highly conserved Gly-Asp-Asp (GDD) motif characteristic of the single-stranded plus RNA viruses RdRp enzyme family<sup>59</sup>. One conclusion from studies of VP1 proteins of the birnaviruses is that they form a defined subgroup of RdRps with significant differences in the arrangement of the predicted catalytic domain of the RdRp enzyme family<sup>59</sup>.

#### 2.4.2. Segment A encoded proteins

Translation of the larger of the two genomic segments, segment A, yields a 106-kDa polyprotein which protein order is, as earlier mentioned, NH2-pVP2- VP4-VP3-COOH. A small protein, VP5, is encoded by a small ORF in a different reading frame, but it is not present in all virus isolates. The VP5 is an arginine-rich minor polypeptide, which is found in infected cell lysates, but not in virions<sup>44</sup>.



The polyprotein is processed by an intramolecular process by self-cleavage exerted by the VP4 partly during the translation process at the pVP2-VP4 and the VP4-VP3 junctions. The pVP2 is further converted to mature VP2 which is a process that involves the cleavage (or cleavages) of pVP2 near the carboxy end. The pVP2 to VP2 processing is slow. Expression of the polyprotein *in vitro* translation experiments or in baculovirus-derived systems produces pVP2 without the further processing of pVP2 to VP2<sup>15</sup>. The processing of pVP2 to VP2 has consequently been proposed to be performed by host cell proteases rather than the proteolytic action of the VP4<sup>15</sup>. An alternative explanation may be that the pVP2-to-VP2 conversion is not an intramolecular process but requires that VP4 from other polyproteins are present (a bi-molecular reaction). If so, the local concentration of pVP2 and VP4 may dramatically influence the rate of conversion pVP2 to VP2 in infected cells. It is likely that the concentration of viral proteins is higher at the capsid assembly site than it is in recombinant expression systems. This may be the reason why *in vitro* translated and baculo-expressed polyproteins ends in an arrest at the pVP2 stage. A conclusion would be that it is not known if the pVP2 to VP2 process is driven by cellular proteases or by the viral protease. The conversion of pVP2 to the VP2 mature form is probably associated with assembly of the virus particle.

The exact cleavage sites at the pVP2-VP4 and at the VP4-VP3 junctions have been determined.

The polyprotein itself has been detected, without the use of protease inhibitors, by Western blotting, both in infected cells and in purified virus, indicating that a small proportion of the polyprotein naturally escapes the co-translationally VP4-cleavage<sup>44</sup>.



## VP2

Analyses of viral proteins early on concluded that VP2 is the major structural and immunogenic polypeptide of the virus. Serotype-specific epitopes<sup>42</sup> and epitopes for neutralizing MAbs<sup>24, 27, 42</sup> have been mapped to this protein.

## Variation & Neutralizing epitopes

A highly variable region in the central third of the VP2 gene, corresponding to amino acid 183(243)-335 of the polyprotein, was originally described by Hepell<sup>27</sup> and later confirmed by others<sup>2</sup>. This area encompasses two hydrophilic hyper variable segments<sup>27</sup>. Hydrophilic areas will naturally be part of the surface of the virion, and thus possibly important antigenic sites. In an experiment where viral mutants that escaped from neutralizing anti-VP2 MAbs were selected, sequencing of three mutants revealed a single amino acid substitution in the hyper variable segments in each of them<sup>27</sup>. The neutralizing MAbs used in that experiment were directed against discontinuous epitopes. Another work in which epitope mapping using MAbs and *E. coli*-expressed truncated fragments of VP2 of the N1 strain were used, confirmed that the central third of VP2 contain neutralization epitopes, both variable and conserved among serogroup A strains of IPNV<sup>24</sup>.

## Glycosylated or not?

*There is a need to ascertain if glycosylation of IPNV is a general trait, or if it is just a consequence of cultivation in special cell lines. Furthermore, which part of VP2 is glycosylated (if it is a general trait), and is it of importance for antigenic properties? Should this putative glycosylation influence the procedures for vaccine production, (i.e. E. coli is known not to glycosylate proteins)?*

Glycosylation of VP2 or not has been a matter of controversy. This seemingly academic question may have consequences for cell and species tropism, for epitope structures and thus for vaccine preparation.

By trying to label IPNV with <sup>3</sup>H- mannose it was found that VP2 contains carbohydrate residues, i.e. it is a glycosylated protein<sup>21</sup>. This was unexpected because IPNV is a non-enveloped virus and it is a general rule that only virus proteins embedded in envelopes are glycosylated. These findings were then also disputed. The usual glycosylation pathway for a protein in a cell involves transportation to the ER and Golgi with addition of carbohydrates there. There is a signal peptide in the amino terminal end of proteins that directs this pathway. In a study by Perez et al. no consensus signal peptide sequence in the VP2 protein was found nor was there any evidence that VP2 is inserted into cytoplasmic membranes during synthesis<sup>51</sup>. In addition, carbohydrate addition should cause an increase in the apparent molecular weight of a protein, and this could not be demonstrated for any of the IPNV proteins. The infectious cycle of IPNV is, furthermore, insensitive to tunicamycin, a substance that inhibits the cell glycosylation machinery<sup>51</sup>. This, in-depth study, concluded that none of the structural proteins of IPNV are glycosylated. However, there are two known ways in which carbohydrate can be added to virus proteins, either by N-linking or by O-linking. In the paper by Perez et al. only N-linking was tested. In a later study by Hjalmarsson et al, where IPNV was propagated in RTG-2 cells, evidence was found for O-glycosylation of VP2<sup>29</sup>. They demonstrated the presence of mannose residues associated with VP2 in virus preparations. By using many different lectins, which binds to carbohydrates, the indication was that the glycosylation of VP2 is O-linked when virions are propagated in RTG-2 cells<sup>29</sup>. For O-linked carbohydrates the linkage between GalNAc and serine or threonine residues are best known, and further requirements in specific amino acid motifs to establish this linkage are not known. It is possible that different cell lines give rise to different types of glycosylation, quantitatively and/or qualitatively.

...could cell lines facilitate glycosylation?...

In a study of the temporal intracellular localization of VP2 and VP3 using MAbs conjugated with fluorochromes it was found that early in the infection cycle both proteins co-localized in the cytosol. VP2 was also visualized as inclusion bodies around the nuclei of the cells and, sometimes, it was found in elongated tubular structures. VP2 was not found to co-localize with ER and Golgi<sup>20</sup>.

Together these results suggest that VP2 is glycosylated and that this glycosylation occurs freely in the cytoplasm and not in ER and Golgi. However, the amount of glycosylation must be limited due to lack of change of migration pattern (i.e. size).

Running the VP2 amino acid sequence (N1 strain) in an O-glycosylation prediction program (in own lab) (NetOGlyc 2.0) indicated that there are at least three potential O-glycosylation sites in the highly variable region in the central third of the VP2 gene.

## Molecular determinants of virulence in VP2?

*In general, for IPNV there is a lack of description of virus properties with relevance for virulence. There are many outbreaks of IPN in fry and around smoltification/sea transfer that would classify as outbreaks caused by an assumed virulent virus. Are there common genetic traits for these IPN viruses? A systematic detailed genetic classification of IPNV isolated in Norway from different disease outbreaks as well with viruses isolated from covert infections could elucidate possible genetic traits behind virus virulence factors. This ought to have priority in studies of virulence and pathogenesis, and should be coupled to establishing IPNV reverse genetics system in a (Norwegian) lab. It should be aimed at establishing a reverse genetics system that are not based on the cRNA transfection that has so far been used for IPNV, but a more advanced system in which the replication complex is added by its own encoding DNA. Such, latter systems seem to be more versatile. The initial findings by Santi et al. (submitted) indicate that some amino acid residues of the VP2 of Norwegian strains of IPNV may be involved in virulence, and it is thus encouraging to follow this path.*

*The finding that IBDV that has been attenuated by a reverse genetics technique induces protection in chicken against IBD could indicate that this path should be considered for IPN.*

Molecular virulence determinants have been extensively mapped in IBDV in chicken. For comparative reasons a short presentation of the findings of VP2 on IBDV is presented. As mentioned, some strains of the IBDV are very virulent and these have thus been used to



determine virulence factors. Such studies used different reverse-genetics systems that have been developed for IBDV. Reverse genetics imply that a DNA copy of the viral genome is made and virus-RNA, and subsequent complete virus particles, is recovered from this DNA after transfection of cells with the DNA copy (in the first birnavirus reverse genetic system a RNA copy of the genome was transfected into cells). DNA, but not RNA, can be manipulated enzymatically in the lab by different techniques, *i.e.* changes of single amino acid residues in the encoded proteins can be made.

In the IBDV system chimeric viruses in which VP4, VP4-VP3, and VP1 encoding sequences of a virulent strain were substituted for the corresponding genes in a non-virulent vaccine strain failed to induce disease<sup>5</sup>. In contrast, chimeric viruses in which the VP2 encoding region of the vaccine strain was replaced with the VP2 of virulent strains behaved similar to virulent strains. These results show that important virulence and pathogenic-phenotype markers of IBDV reside in VP2. Moreover, one of the chimeric viruses containing VP2 of the virulent strain could not be recovered in cells used for propagation of the vaccine strain, suggesting that VP2 contains the determinants for cell tropism<sup>5</sup>. By comparing the deduced amino acid sequences of the different strains and their reactivity with virulent IBDV specific MABs, the putative amino acids involved in virulence and cell tropism were identified<sup>5</sup>. In a more detailed study in which reverse genetics technology was combined with site-directed mutagenesis it was demonstrated that alteration of two amino acids in VP2 of a very virulent IBDV completely attenuated the virus<sup>66</sup>. This attenuated virus also induced protection in chickens when they later were challenged with very virulent IBDV. The data demonstrate that VP2 plays a decisive role in pathogenicity of IBDV.

It is well known that the cumulative mortalities after outbreaks of IPN in fry may vary from below 10% to more than 90% depending on the combination of several factors, such as virus strain<sup>46</sup> and challenge dose<sup>49</sup> and environmental and host factors. This implies that some strains of IPNV are more virulent than others, i.e. there are viral virulence factors. In a study by Sano et al. intertypic reassortants were made between two IPNV strains that were pathogenic (Buhl) and non-pathogenic (European virus eel) for brook trout fry and they concluded that the virulence of IPNV was found to be coupled to segment A<sup>57</sup>. Bruslind and Reno sequenced the VP2 and VP3 genes for three strains of IPNV with different virulence before the viruses were introduced into the fish, during the epizootic, and 2 months after exposure and their data indicated that two amino acid differences in the VP2 region exist, at residues 217 and 286 in the strain they used, distinguishing the least-virulent isolates and the most-virulent isolate<sup>6</sup>. They tentatively suggested that these amino acid differences might account for the disparity in expressed virulence<sup>6</sup>.

The same group that first developed a reverse genetics system for IBDV developed a similar system for IPNV using the West Buxton strain, with transfection of plus-strand RNA transcripts derived from cloned cDNA<sup>70</sup>. A prerequisite for the construction of infectious clones of IPNV was the identification of the precise 5'-and 3'-terminal sequences, which are crucial for replication of viral RNA. The authors tried to make chimeric viruses between IPNV and IBDV by changing the genomic segment B between the viruses; however, no "new" virus was produced as a consequence of this, concluding that the RdRps for these viruses are species specific. The authors stated: "the reverse genetics system for IPNV should facilitate studies of viral replication and pathogenesis and the design of a new generation of live attenuated vaccines". However, this has so far not been utilized in the same manner as for IBDV.

### VP3

*Studies possibly lacking: Is the VP3 specific neutralizing epitope(s) present in all IPNV strains? Is this (potential) epitope(s) of significance for protection?*

The second major structural protein, VP3, is known to be absent in empty capsids, i.e. capsids or virus-like particles that lack viral RNA<sup>15</sup>, and VP3 has been referred to as an internal protein<sup>15</sup>. The lack of presence of VP3 in empty capsids demonstrates that VP2 is capable to make this structure alone. However, there are several reports dealing with the specific binding of MAbs against VP3 indicating that some part of VP3 is exposed on the surface of the virion. MAbs against VP3 have been shown to react with linear epitopes<sup>64</sup>, and also to recognize VP3 on purified IPNV in ELISAs, as well as in immunodot assays<sup>8</sup>, and thus VP3 is exposed on the surface of the virus particle. VP3 specific polyclonal mouse sera (PAbs) have also been found to contain neutralizing capacity<sup>50</sup>.

...binding of VP2 to VP3 is weaker than the VP3-RNA association...

In a study using highly purified IPNV, disintegrated virions, VP3 specific MAbs, and EM showed that VP3 is intimately associated with the segments of viral RNA<sup>29</sup>. Of the last 43 carboxy terminal amino acid residues, 25% consist of the basic amino acids arginine and lysine<sup>19</sup>, and it is logical to believe that this part of the protein is intimately connected with the viral genome.

Although these authors did not conclude that VP3 is a part of the capsid or not, their results indicated that the binding of VP2 to VP3, if there is any, is weaker than the VP3-RNA association<sup>29</sup>.

VP3a is a protein that has a size that is slightly less than VP3 and considered to be a cleavage product of VP3. It has been found in mature virus particles in some strains of IPNV<sup>15</sup>.

#### VP4 –protease (NS)

*Although there are examples in which the function of viral proteases has been coupled to virulence, there are no publications connecting the function of VP4 to specific properties of different strains of IPNV.*

The functions of VP4 in the cleavage of the polyprotein were described in the “Segment A protein” introduction part. The action of VP4 cannot be inhibited by supraoptimal temperatures, amino acid analogues, or known protease inhibitors<sup>16</sup>. The birnavirus (i.e. IPNV, IBDV, and DSXV) proteases have been studied in detail by Delmas’ group and they concluded that these proteases represent a new type of viral serine protease<sup>41, 52</sup>. These proteases recognize the amino acid motif Ser/Thr-X-Ala- -Ser/Ala, a motif that shares some similarities with bacterial signal peptidase and herpes simplex virus cleavage sites. The authors also found some sequence homologies between IPNV, IBDV, and DSXV VP4s, i.e. some amino acids were indispensable for a proper function of the proteases, suggesting that these amino acids were related to structural constraints for the folding of these proteases.

#### VP5

VP5 is, as mentioned earlier, a 17-kDa non-structural protein encoded by the 5’-terminal, small ORF in segment A. This gene is expressed early in the replication process<sup>44</sup>. Analysis of the segment A sequences from five different virus strains revealed that the small ORF was not present in one of them, and truncated on two others<sup>26</sup>. Moreover, the deduced amino acid sequences did not appear to be well conserved. The logic consequences of this is that VP5 is dispensable for IPNV, and that it is not conserved on the behalf of VP2, but rather vice versa.

...VP5 has antiapoptotic effect...

Hong et al. have revealed the function of VP5 in the IPNV replication cycle<sup>30-33</sup>. Their main conclusions are that VP5 antagonize the host defence system that triggers apoptosis, and influence the viral-induced cellular death gene expression that occurs in early replication stage, thus possibly enhancing the virus production.

#### IPNV induced cytopathic effect: apoptosis precedes detectable necrotic changes.

*The findings indicate that VP5 is important for the cross talk between the virus and the cell, and that this protein is developed as a consequence of the intimate relationship between the cell and the virus. It is also an example of the complexity that is found when this relationship is revealed in detail. That VP5 seems to be dispensable for IPNV is intriguing. It is logic to assume that the effect of VP5 is to increase the output of viral progeny from an infected cell. Is it then a virulence factor? Is the VP5 ORF always present in IPNV isolated from Norway? Are there any differences between isolates from disease outbreaks compared to for instance from covert infections?*

The IPNV replication process is localized in the cytoplasm and a single replication cycle takes about 16–20 h at 22°C, resulting in a characteristic cytopathic effect (CPE). A detailed study of the development of CPE in CHSE-214 cells after IPNV-infection showed that the cells die by apoptosis with all its associated characteristics: DNA fragmentation,



nuclear and cellular segmentation, multi micronuclei formation, and, finally, post apoptotic necrosis<sup>32</sup>. IPNV induce death of a cell by up-regulating a pro-apoptotic death gene (Bad), the expression of which serves to trigger apoptotic cell death<sup>33</sup>. There are many examples of viruses inducing apoptosis. In most cases, apoptosis is a defence mechanism beneficial for the host because it curtails the infection cycle and prevents neighbouring cells from being infected with progeny virus. Like many viruses IPNV has evolved gene-encoding proteins that can suppress or delay apoptosis and consequently maintain host cell survival for the production of viral progeny. By postponing the apoptosis VP5 possibly exerts a positive effect on the viral production.

## 2.5. Replication

Many aspects related to the replication of IPNV have been described in the preceding chapters. Various other aspects will only briefly be mentioned.

### 2.5.1. Entry into cells

In a minor study of the uptake of IPNV into cells the possible requirement of acid pH of endosomes for the virus to entry into the cytosol was assayed by testing the effect of Bafilomycin A1 on IPNV replication<sup>39</sup>. Concentrations of Bafilomycin A1, which inhibited the endosomal acidification of the host cells, did not affect IPNV replication in CHSE-214 cells; therefore, the acid pH of endosomes seems not to be a mandatory condition for the entry of IPNV into cells.



Few amphibian cells support IPNV replication, and no avian or mammalian or insect cell lines have been found to support IPNV replication.

### 2.5.2. Temperature sensitivity

Using the Jasper strain of IPNV Roberts and Dobos found that the yields of infectious pancreatic necrosis virus from fathead minnow (FHM) cell cultures were maximal at 20 °C<sup>54</sup>. They found a temperature-dependent block in virus production at 28 °C, and at this temperature neither virus-specific mRNA nor virus-specific polypeptides could be detected. The virus infectivity was not inactivated nor was there any inability of the virus to adsorb to cells at 28 °C. Their analysis indicated that multiple temperature-sensitive steps were involved in the inhibition of virus replication at 28 °C. The RdRp (VP1) functions well *in vitro* at temperatures above 30 °C<sup>15</sup>.

### 2.5.3. Uncoating

The virion associated RdRp is active without proteolytic treatment of the virus. This indicates that uncoating may not be a precondition for virus replication<sup>15</sup>.

### 2.5.4. Noncoding sequences of segment A and B

There is extensive homology between the noncoding sequences of IPNV segments A and B. For example, 32 of 50 nucleotides at the 5'-noncoding region and 29 of 50 nucleotides at the 3'-noncoding region between the two segments are conserved<sup>15</sup>. These sequences likely contain signals important for the replication and packaging of the IPNV genome.

### 2.5.5. Differences in mRNA synthesis

*There is a lack of knowledge of both the entry and expression pattern of IPNV. The cellular entry may influence possible species specificity of the virus. However, this should be*



*considered as basic research and practical utilization of such research is unlikely to be straightforward. That uncoating is not a precondition for virus replication may be a protective measure exerted by the virus against interferon induction?*

The structure of the 5'-end of IPNV mRNA has not been determined, but the 3'-end do not contain a polyA tract<sup>15</sup>.

Segment A specific mRNA is synthesized in larger amounts (2-3 times) than the segment B mRNA, reflecting the relative abundance of the viral proteins (i.e. there are more segment A than B proteins)<sup>15</sup>. It is not known which structures that direct this.

Examinations of the nucleotide sequences around the start codons for VP1, polyprotein and VP5 revealed that none of these have a strong consensus start sequence (ANNAUGG)<sup>15</sup>. Thus, the differences between segment A and B expression pattern cannot be explained by obvious differences in affinity for ribosomal binding. This could indicate that internal translation initiation on segment A could be biologically significant, i.e. that not only the polyprotein is expressed from segment A but internal initiations for expression may occur as well. The IPNV gene expression is probably more complex than believed.

## 2.6. Pathogenesis

A lot of the information given under the previous “virus” heading might just as well have been put under the heading “pathogenesis”. Together the information indicates a well-developed intimate relationship between IPNV and its host.

Some old findings (in the category “everybody knows?) deserve to be re-examined. And some important data related to pathogenesis from previous chapters are restated:

- VP2 is the prime candidate virus protein likely to be involved in virulence properties of the virus.
- VP5 has anti apoptotic properties.
- IPNV induces apoptosis before necrosis is prevalent
- Nucleotide sequence alignments of different strains of aquatic birnaviruses indicate geographical relation rather than species relation (this picture is not uniform).

### 2.6.1. Age and susceptibility

Wolf and Quimby published in 1969 that mortalities due to IPN are greatly reduced when the trout reach the late fry and fingerling stage<sup>68</sup>. Frantsi and Savan, found similar pattern using brook trout as challenge species; fry was most susceptible before 4 months of age, and they also reported temperature dependence for mortality<sup>23</sup>. Later studies supported these findings, and to summarize: Susceptibility to IPN generally decreases with age, with resistance to clinical disease in salmonid fish usually being reached at about 1500 degree-days<sup>17</sup>, except for Atlantic salmon smolts, which can suffer from disease shortly after transfer from fresh water to seawater<sup>4</sup> (4.2.2.). Dorson and Torchy also found that mortalities were highest for temperatures between 10-16 °C<sup>17</sup>. These latter authors also tested survivors after challenge of fry for production of neutralizing antibodies and concluded that none of the few survivors could be considered as immunologically tolerant.

...resistance in Salmonids from about 1500 degree-days...

### 2.6.2. Organ tropism

*What are the mechanisms behind the age-dependent protection found in salmonids? Is it of innate or acquired origin? This is a pivotal question. Is there a “break” of this protective mechanism when IPN occur at the smolt stage, or are other mechanisms of importance? These questions are possibly very difficult to answer scientifically. However, emphasis should be put on this problem. For instance, with the upcoming use of DNA array systems it may be possible to elucidate which genes that are most likely involved in the age dependent protection. Secondly, is it possible to induce this response to create a “resistant mode” in the critical phases for IPN of the salmon life?*

After i.p. injection of Atlantic salmon and brook trout fry with the VR299 strain pathological changes was found in pancreatic tissue after 2 days, pathological changes to a minor extent were also found in kidney and liver<sup>17</sup>. Early studies by Swanson and Gillespie using fluorescent antibodies technique found fluorescence only in pancreas, liver and kidney<sup>61</sup>.

### 2.7. Detection

*There will be a continuous improvement of laboratory diagnosis and detection of IPN/IPNV along with the development of new and more sophisticated methods. Detection of IPNV with special properties i. e. virulent types/strains requires that molecular basis for these properties are well and unequivocally described.*

*An evaluation of the ability of a test to detect IPNV includes evaluation of both the specificity and sensitivity. This requires a gold standard to compare against. The gold standard for IPNV detection is virus isolation in cell culture, which is thoroughly described in the OIE manual. The sensitivity of an assay can be divided into analytical sensitivity i.e. when cultivated material is tested and diagnostic sensitivity when samples from fish is tested.*

The basic question is: What is the intention of the detection?

1. Solely to detect the presence of IPNV or not?
  2. Quantitative presence of IPNV?
  3. Relationship between virus presence and pathological changes?
  4. Qualitative properties of the IPNV present?
1. This is thoroughly discussed in the OIE manual. Detailed, quality tested procedures for IPNV isolation from salmonids are described. The principles are based on IPNV isolation in BF2 or CHSE-214 cell cultures followed by immunological identification, either by serum neutralization or enzyme-linked immunosorbent assay (ELISA), or today RT-PCR could be used. The sampling described by OIE from apparently healthy fish is to collect liver, kidney and spleen and/or ovarian fluid from brood fish at spawning time. The reason for sampling of these organs is based on findings (described under 2.6) in which virus antigens was found mainly in pancreas, liver and kidneys<sup>61</sup>. Why pancreas is not mentioned in the sampled organs may be due to difficulties to localize these cell islands.

Another option for detection of virus in tissue material is of course the use of RT-PCR, which could be a substitute for virus isolation. RT-PCR is in some studies found to be more sensitive than virus isolation<sup>62</sup>. Rimstad et al first described detection of IPNV by RT-PCR.<sup>53</sup>, and several papers followed this<sup>43, 55, 60, 67</sup>. Blake et

al have described a general aquabirnavirus RT-PCR.<sup>3</sup> The general discussion about the use of RT-PCR versus cell culture is beyond the scope of this summary.

2. If a quantitative presence implies an estimate of the number of IPNV present, cell culture, i.e. end point dilution or plaque-forming units, can be used. An alternative would be quantitative RT-PCR (qRT-PCR). After establishing qRT-PCR this would be the most efficient of these methods. However, any use of quantitation would require that the base line is well established (the amount of virus in persistent infected, clinically healthy fish.) The amount of virus in acute phase of the disease has been estimated to be  $10^4$ - $10^8$  TCID<sub>50</sub>/g tissue. This rather big variation range,  $10^4$ - $10^8$  TCID<sub>50</sub>/g tissue, can imply that it will be difficult to use quantitation of virus in predictive way (?).
3. The use of immunohistochemistry is (IHC) well established for this purpose<sup>22</sup>, and may be confirmed by isolation of IPNV in tissue culture. Other alternatives like immune fluorescence (IFAT) may of course be used, but this requires special equipment. The benefits of IHC versus IFAT is less background staining, ordinary microscope may be used, and storage of the slides for a long time. A more crude method to establish the relation between pathological/clinical changes and IPNV presence is the use of agglutination using sensitised staphylococci<sup>38</sup>. This method may be well suited as a first line method in field detection of clinical outbreaks<sup>63</sup>. The minimum IPNV titre needed to obtain a positive agglutination using sensitised staphylococci has been estimated to be approximately  $10^5$  TCID<sub>50</sub>/ ml.
4. This will require that virulence properties are properly described in Norwegian IPNV isolates.

Due to insufficient knowledge of the serological responses of fish to virus infections, the detection of fish antibodies to viruses has not thus far been accepted as a routine screening method for assessing the viral status of fish populations.

## 2.8. References

1. Ahne, W. 1978. Isolation and characterization of infectious pancreatic necrosis virus from pike (*Esox lucius*). *Arch. Virol.* **58**:65-69.
2. Blake, S., J. Y. Ma, D. A. Caporale, S. Jairath, and B. L. Nicholson. 2001. Phylogenetic relationships of aquatic birnaviruses based on deduced amino acid sequences of genome segment A cDNA. *Dis. Aquat. Organ.* **45**:89-102.
3. Blake, S. L., W. B. Schill, P. E. McAllister, M. K. Lee, J. T. Singer, and B. L. Nicholson. 1995. Detection and identification of aquatic birnaviruses by PCR assay. *J. Clin. Microbiol.* **33**:835-839.
4. Bowden, T. J., D. A. Smail, and A. E. Ellis. 2002. Development of a reproducible infectious pancreatic necrosis virus challenge model for Atlantic salmon, *Salmo salar* L. *J. Fish Dis.* **25**:555-563.
5. Brandt, M., K. Yao, M. H. Liu, R. A. Heckert, and V. N. Vakharia. 2001. Molecular determinants of virulence, cell tropism, and pathogenic phenotype of infectious bursal disease virus. *J. Virol.* **75**:11974-11982.
6. Bruslind, L. D. and P. W. Reno. 2000. Virulence comparison of three buhl-subtype isolates of infectious pancreatic necrosis virus in brook trout fry. *J. Aquatic Animal Health* **12**:301-315.
7. Calvert, J. G., E. Nagy, M. Soler, and P. Dobos. 1991. Characterization of the VPg-dsRNA linkage of infectious pancreatic necrosis virus. *J. Gen. Virol.* **72**:2563-2567.
8. Caswell-Reno, P., P. W. Reno, and B. L. Nicholson. 1986. Monoclonal antibodies to infectious pancreatic necrosis virus: analysis of viral epitopes and comparison of different isolates. *J. Gen. Virol.* **67**:2193-2205.
9. Chong LK, F. A. U., F. A. U. Omar AR, K. F. Yusoff, M. F. Hair-Bejo, and I. Aini. 2001 Nucleotide sequence and phylogenetic analysis of a segment of a highly virulent strain of infectious bursal disease virus. *Acta Virol.* **45**: 217-226.
10. Christie, K. E., S. Ness, and H. O. Djupvik. 1990. Infectious pancreatic necrosis virus in Norway - partial serotyping by monoclonal-antibodies. *J. Fish Dis.* **13**:323-327.
11. Cutrin, J. M., J. G. Oliveira, J. L. Barja, and C. P. Dopazo. 2000. Diversity of infectious pancreatic necrosis virus strains isolated from fish, shellfish, and other reservoirs in Northwestern Spain. *Appl Environ. Microbiol.* **66**:839-843.
12. Da Costa, B., S. Soignier, C. Chevalier, C. Henry, C. Thory, J. C. Huet, and B. Delmas. 2003. Blotched snakehead virus is a new aquatic birnavirus that is slightly more related to avibirnavirus than to aquabirnavirus. *J. Virol.* **77**:719-725.
13. Dobos, P. 1993. In vitro guanylation of infectious pancreatic necrosis virus polypeptide VP1. *Virology* **193**:403-413.
14. Dobos, P. 1995. Protein-primed RNA synthesis in vitro by the virion-associated RNA polymerase of infectious pancreatic necrosis virus. *Virology* **208**:19-25.
15. Dobos, P. 1995. The molecular biology of infectious pancreatic necrosis virus. *Annual Review of Fish Diseases* **5**:25-54.
16. Dobos, P., R. Hallett, D. T. Kells, O. Sorensen, and D. Rowe. 1977. Biophysical studies of infectious pancreatic necrosis virus. *J. Virol.* **22**:150-159.
17. Dorson, M. and C. Torchy. 1981. The influence of fish age and water temperature on mortalities of rainbow-trout, *Salmo gairdneri* Richardson, caused by a European strain of infectious pancreatic necrosis virus. *J. Fish Dis.* **4**:213-221.
18. Duncan, R., C. L. Mason, E. Nagy, J. A. Leong, and P. Dobos. 1991. Sequence analysis of infectious pancreatic necrosis virus genome segment B and its encoded VP1 protein: a putative RNA-dependent RNA polymerase lacking the Gly-Asp-Asp motif. *Virology* **181**:541-552.
19. Duncan, R., E. Nagy, P. J. Krell, and P. Dobos. 1987. Synthesis of the infectious pancreatic necrosis virus polyprotein, detection of a virus-encoded protease, and fine structure mapping of genome segment A coding regions. *J. Virol.* **61**:3655-3664.
20. Espinoza, J. C., A. Hjalmarsson, E. Everitt, and J. Kuznar. 2000. Temporal and subcellular localization of infectious pancreatic necrosis virus structural proteins. *Arch. Virol.* **145**:739-748.
21. Estay, A., G. Farias, M. Soler, and J. Kuznar. 1990. Further analysis on the structural proteins of infectious pancreatic necrosis virus. *Virus Res.* **15**:85-95.
22. Evensen, O. and E. Rimstad. 1990. Immunohistochemical identification of infectious pancreatic necrosis virus in paraffin-embedded tissues of Atlantic salmon (*Salmo salar*). *J. Vet. Diagn. Invest.* **2**:288-293.
23. Frantsi, C. and M. Savan. 1971. Infectious pancreatic necrosis virus-temperature and age factors in mortality. *Wildl. Dis.* **7**:249-255.
24. Frost, P., L. S. Havarstein, B. Lygren, S. Stahl, C. Endresen, and K. E. Christie. 1995. Mapping of neutralization epitopes on infectious pancreatic necrosis viruses. *J. Gen. Virol.* **76**:1165-1172.

25. Heppell, J., L. Berthiaume, F. Corbin, E. Tarrab, J. Lecomte, and M. Arella. 1993. Comparison of amino acid sequences deduced from a cDNA fragment obtained from infectious pancreatic necrosis virus (IPNV) strains of different serotypes. *Virology* 195:840-844.
26. Heppell, J., E. Tarrab, L. Berthiaume, J. Lecomte, and M. Arella. 1995. Characterization of the small open reading frame on genome segment A of infectious pancreatic necrosis virus. *J. Gen. Virol.* 76:2091-2096.
27. Heppell, J., E. Tarrab, J. Lecomte, L. Berthiaume, and M. Arella. 1995. Strain variability and localization of important epitopes on the major structural protein (VP2) of infectious pancreatic necrosis virus. *Virology* 214:40-49.
28. Hill, B. J. and K. Way. 1995. Serological classification of infectious pancreatic necrosis (IPN) virus and other aquatic birnaviruses, *Annual Review of Fish Diseases* 5: 55-77.
29. Hjalmarsson, A., E. Carlemalm, and E. Everitt. 1999. Infectious pancreatic necrosis virus: identification of a VP3-containing ribonucleoprotein core structure and evidence for O-linked glycosylation of the capsid protein VP2. *J Virol.* 73:3484-3490.
30. Hong, J. R., H. Y. Gong, and J. L. Wu. 2002. IPNV VP5, a novel anti-apoptosis gene of the Bcl-2 family, regulates Mcl-1 and viral protein expression. *Virology* 295 :217-229.
31. Hong, J. R., Y. L. Hsu, and J. L. Wu. 1999. Infectious pancreatic necrosis virus induces apoptosis due to down-regulation of survival factor MCL-1 protein expression in a fish cell line. *Virus Res.* 63:75-83.
32. Hong, J. R., T. L. Lin, Y. L. Hsu, and J. L. Wu. 1998. Apoptosis precedes necrosis of fish cell line with infectious pancreatic necrosis virus infection. *Virology* 250:76-84.
33. Hong, J. R. and J. L. Wu. 2002. Induction of apoptotic death in cells via Bad gene expression by infectious pancreatic necrosis virus infection. *Cell Death. Differ.* 9:113-124.
34. Hoque MM, F. A. U., Omar AR FAU - Hair-Bejo, M. F. Hair-Bejo, and I. Aini. 2002 Sequence and phylogenetic analysis of the VP2 gene of very virulent infectious bursal disease virus isolates. *J. Biochem Mol Biol Biophys.* 6:93-99.
35. Hsu, Y. L., C. C. Chen, and J. L. Wu. 1995. Molecular relationships in infectious pancreatic necrosis virus. *Virus Res.* 37:239-252.
36. Islam, M. R., K. Zierenberg, and H. Muller. 2001. The genome segment B encoding the RNA-dependent RNA polymerase protein VP1 of very virulent infectious bursal disease virus (IBDV) is phylogenetically distinct from that of all other IBDV strains. *Archives of Virology* 146:2481-2492.
37. Jorgensen. P.E. and Bregnballe. F. 1969. Infectious pancreatic necrosis in rainbow trout (*Salmo gairdneri*) in Denmark. *Nordisk Veterinaer Medicin* 21:142-&.
38. Kimura, T., M. Yoshimizu, and H. Yasuda. 1984. Rapid, simple serological diagnosis of infectious pancreatic necrosis by coagglutination test using antibody-sensitized staphylococci. *Fish Pathology* 19:25-33.
39. Kuznar, J., M. Soler, G. Farias, and J. C. Espinoza. 1995. Attachment and entry of infectious pancreatic necrosis virus (IPNV) into CHSE-214 cells. *Arch. Virol.* 140 :1833-1840.
40. Lee, M. K., S. L. Blake, J. T. Singer, and B. L. Nicholson. 1996. Genomic variation of aquatic birnaviruses analyzed with restriction fragment length polymorphisms. *Appl. Environ. Microbiol.* 62:2513-2520.
41. Lejal, N., B. Da Costa, J. C. Huet, and B. Delmas. 2000. Role of Ser-652 and Lys-692 in the protease activity of infectious bursal disease virus VP4 and identification of its substrate cleavage sites. *J Gen. Virol.* 81:983-992.
42. Liao, L. and P. Dobos. 1995. Mapping of a serotype specific epitope of the major capsid protein VP2 of infectious pancreatic necrosis virus. *Virology* 209:684-687.
43. Lopezlastra, M., M. Gonzalez, M. Jashes, and A. M. Sandino. 1994. a detection method for infectious pancreatic necrosis virus (IPNV) based on reverse transcription (RT)-polymerase chain- reaction (PCR). *J. Fish Dis.*17:269-282.
44. Magyar, G. and P. Dobos. 1994. Evidence for the detection of the infectious pancreatic necrosis virus polypeptide and the 17-kDa polypeptide in infected cells and of the NS protease in purified virus. *Virology* 204:580-589.
45. Majo, N. F., J. F. El Attrache, A. F. Banda, P. F. Villegas, A. F. Ramis, A. F. Pages, and N. Ikuta. 2002 Molecular characterization of Spanish infectious bursal disease virus field isolates. *Avian Dis.* 46:859-868.
46. McAllister, P. E. and W. J. Owens. 1995. Assessment of the virulence of fish and molluscan isolates of infectious pancreatic necrosis virus for salmonid fish by challenge of brook trout, *Salvelinus-fontinalis* (mitchill). *J. Fish Dis.*18:97-103.
47. Melby, H. P. and K. E. Christie. 1994. Antigenic analysis of reference strains and norwegian field strains of aquatic birnaviruses by the use of 6 monoclonal- antibodies produced against the infectious pancreatic necrosis virus N1 strain. *J. Fish Dis.*17:409-415.



48. Mertens, P. P. C., P. B. Jamieson, and P. Dobos. 1982. In vitro RNA-synthesis by infectious pancreatic necrosis virus-associated RNA-polymerase. *J. Gen. Virol.* 59:47-56.
49. Okamoto, N., Y. Seno, N. Taniguchi, and T. Sano. 1987. Relationship between inoculative quantity of infectious pancreatic necrosis virus and the mortality of rainbow-trout fry. *Nippon Suisan Gakkaishi* 53:1975-1978.
50. Park, J. W. and G. J. Jeong. 1996. Identification of VP3 as an important neutralising epitope from DRT strain, a Korean isolate of infectious pancreatic necrosis virus (IPNV). *Fish & Shellfish Immunol.* 6:207-219.
51. Perez, L., P. P. Chiou, and J. C. Leong. 1996. The structural proteins of infectious pancreatic virus are not glycosylated. *J. Virol.* 70:7247-7249.
52. Petit, S., N. Lejal, J. C. Huet, and B. Delmas. 2000. Active residues and viral substrate cleavage sites of the protease of the birnavirus infectious pancreatic necrosis virus. *J. Virol.* 74:2057-2066.
53. Rimstad, E., E. Hornes, O. Olsvik, and B. Hyllseth. 1990. Identification of a double-stranded RNA virus by using polymerase chain reaction and magnetic separation of the synthesized DNA segments. *J. Clin. Microbiol.* 28:2275-2278.
54. Roberts, T. E. and P. Dobos. 1983. Studies on the mechanism of temperature sensitivity of infectious pancreatic necrosis virus replication. *J. Gen. Virol.* 64:331-339.
55. Rodriguez, S., M. Alonso, and S. I. Perez-Prieto. 2001. Detection of infections pancreatic necrosis virus (IPNV) from leukocytes of carrier rainbow trout *Oncorhynchus mykiss*. *Fish Pathology* 36:139-146.
56. Rudd M.F., H.G. Heine, S.I. Sapats, L. F. Parede, and J. Ignjatovic. 2002 Characterisation of an Indonesian very virulent strain of infectious bursal disease virus. *Arch Virol.* 147:1303-1322.
57. Sano, M., N. Okamoto, H. Fukuda, M. Saneyoshi, and T. SANO. 1992. Virulence of infectious pancreatic necrosis virus is associated with the larger RNAsegment (RNAsegment-A). *J. Fish Dis.* 15:283-293.
58. Sano, T. 1971. Viral diseases of Japanese fishes .1. Infectious pancreatic necrosis of rainbow trout - first isolation from epizootics in Japan. *Bull. Jap. Soc. Scien. Fish.* 37:495-498.
59. Shwed, P. S., P. Dobos, L. A. Cameron, V. N. Vakharia, and R. Duncan. 2002. Birnavirus VP1 proteins form a distinct subgroup of RNA-dependent RNA polymerases lacking a GDD motif. *Virology* 296:241-250.
60. Suzuki, S., N. Hosono, and R. Kusuda. 1997. Detection of aquatic birnavirus gene from marine fish using a combination of reverse transcription-and nested PCR. *J. Marine Biotech.* 5:205-209.
61. Swanson, R. N. and J. H. Gillespie. 1981. An indirect fluorescent-antibody test for the rapid detection of infectious pancreatic necrosis virus in tissues. *J. Fish Dis.* 4:309-315.
62. Taksdal, T., B. H. Dannevig, and E. Rimstad. 2001. Detection of infectious pancreatic necrosis (IPN)-virus in experimentally infected Atlantic salmon parr by RT-PCR and cell culture isolation. *Bull. Eur. Ass. Fish Pathol.* 21:214-219.
63. Taksdal, T. and K. Thorud. 1999. Evaluation of a rapid coagglutination (COA) test for the detection of infectious pancreatic necrosis virus (IPNV) in tissue samples of Atlantic salmon, *Salmo salar* L. *J. Fish Dis.* 22:117-124.
64. Tarrab, E., L. Berthiaume, J. Heppell, M. Arella, and J. Lecomte. 1993. Antigenic characterization of serogroup 'A' of infectious pancreatic necrosis virus with three panels of monoclonal antibodies. *J. Gen. Virol.* 74:2025-2030.
65. Underwood, B. O., C. J. Smale, F. Brown, and B. J. Hill. 1977. Relationship of a virus from *Tellina tenuis* to infectious pancreatic necrosis virus. *J. Gen. Virol.* 36:93-109.
66. van Loon, A. A. W. M., N. de Haas, I. Zeyda, and E. Mundt. 2002. Alteration of amino acids in VP2 of very virulent infectious bursal disease virus results in tissue culture adaptation and attenuation in chickens. *J. Gen. Virol.* 83:121-129.
67. Wang, W. S., Y. L. Wi, and J. S. Lee. 1997. Single-tube, non-interrupted reverse transcription PCR for detection of infectious pancreatic necrosis virus. *Dis. Aquatic Organ.* 28:229-233.
68. Wolf, K. and M. C. Quimby. 1971. Salmonid viruses - infectious pancreatic necrosis virus - morphology, pathology, and serology of first european isolations. *Archiv fur Die Gesamte Virusforschung* 34:144-156.
69. Wolf, K., S. F. Snieszko, C. E. Dunbar, and E. Pyle. 1960. Virus nature of infectious pancreatic necrosis in trout. *Proc. Soc. Exp. Biol. Med.* 104:105-108.
70. Yao, K. and V. N. Vakharia. 1998. Generation of infectious pancreatic necrosis virus from cloned cDNA. *J. Virol.* 72:8913-8920.
71. Zhang CX, F. A. U. and S. Suzuki. 2003. Comparison of the RNA polymerase genes of marine birnavirus strains and other birnaviruses. *Arch Virol.* 148:745-58.



### 3. Transmission and reservoirs

- There is very little data published about vertical transmission of IPNV
- A conclusive demonstration of whether vertical transmission occurs or not has not been performed
- Shedding rates of IPNV from salmonids is unknown
- Epidemiological case/control studies are essential to understand more about IPNV transmission
- Detection of titre relationships between kidney and gonads should be done
- Greater understanding of the association of IPNV and sperm is needed
- There is indication of titre dependent effects on vertical transmission of IPNV in brook trout
- Carrier fish represents the most significant source of horizontal transmission
- Release of IPNV from reservoirs should be investigated
- Do we really know the significance of horizontal transmission via fomites?

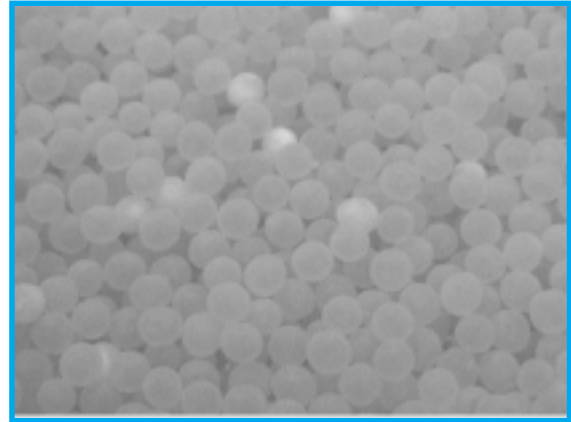

#### 3.1. Vertical Transmission of IPNV

Vertical transmission can be defined as the transmission of an infectious agent from one generation to the next (Martin et al 1987). The agent can either be within the contents of the gametes, often referred to as intra-ovum or true vertical transmission, or alternatively extra ovum on the surface of gametes or in natural ovarian and seminal fluids and mucus. In oviparous species with external fertilisation virus closely associated with sperm is more efficiently transferred to the egg than unassociated virus (Mulcahy & Pascho 1984).

For salmonids, there are very few published reports of the vertical transmission of IPNV. It has been reported in brook trout (Bullock *et al.*, 1976; Wolf et al 1968; Bootland *et al.*, 1991) and rainbow trout (Dorson and Torchy, 1985). However, although there is evidence that IPNV can enter Atlantic salmon eggs via virus adsorbed to sperm, vertical transmission has never been successfully demonstrated in Atlantic salmon (Smail & Munro 1989). IPNV is known to bind to milt via the sperm head (Mulcahy and Pascho, 1984) and this is the likely mechanism whereby the virus enters the egg via the micropyle at the point of fertilisation (Dorson and Torchy, 1985). There is evidence that in experimental infection of eyed arctic char (Ahne & Negele 1985) and rainbow trout eggs (Ahne et al 1989), IPNV could remain infective following adsorption to the hardened shell of the eggs and that

...there is evidence that IPNV can enter Atlantic salmon eggs via virus adsorbed to sperm... IPNV is known to bind to milt via the sperm head...

IPNV was detected in sac-fry (Ahne & Negele 1985). This observation does not provide evidence of vertical transmission but rather indicates that eggshells may be involved in the horizontal transmission of IPNV to first feeding fry.

In general terms, the literature suggests that the probability of vertical transmission to the gametes is proportional to the virus levels in the gonads. Experiments with trout show that high virus titres are important in vertical transmission via the milt (Dorson and Torchy, 1985; Bootland *et al.*, 1991) and circumstantial evidence indicate this may also apply in the case of ovarian fluid (Bootland *et al.*, 1995). In brook trout it was found that virus titres over  $10^4$  TCID<sub>50</sub>/ml in ovarian fluid were correlated with the isolation of IPN virus from egg homogenates (Wolf *et al.* 1963). Therefore  $10^4$  TCID<sub>50</sub> /ml in ovarian fluid may represent a threshold of positive transmission in brook trout (Wolf *et al.*, 1963), however, this postulation was based on isolation data rather than experimental data. Unpublished data from Smail (1983) also provides some evidence of titre dependent effects since embryo survival sharply declines as virus titre increases (Fig 1). Interestingly, although  $10^4$  TCID<sub>50</sub> /ml may represent a threshold for transmission in Brook trout there is some unpublished data which suggests this threshold may be higher in Atlantic salmon. Ovarian fluid can neutralise at least 1 log of cultured IPNV infectivity and the threshold limit shown in Fig 1 is approximately 5-10 virions per sperm suggesting that titres higher than  $10^4$  TCID<sub>50</sub> /ml may be necessary for successful vertical transmission in Atlantic salmon (Smail, unpublished data). Further unpublished data from FRS shows that 1% of broodstock carriers have virus titres from kidney of  $10^4$ - $10^5$  pfu/g (Fig 2). The titre data was from kidney rather than ovarian fluids because data from ovarian fluids itself is too sparse to analyse. Although it is possible this data indicates the proportion of carriers that pose a risk of vertical transmission, care should be taken in calculating risk of vertical transmission based on such data since the relationship between kidney and gonadal titre is unclear. It would be useful to determine the relationship between titres in kidney and gonads and obtain sufficient data from gonadal fluids for robust statistical analyses since this type of analyses is a useful indicator of risk of vertical transmission.

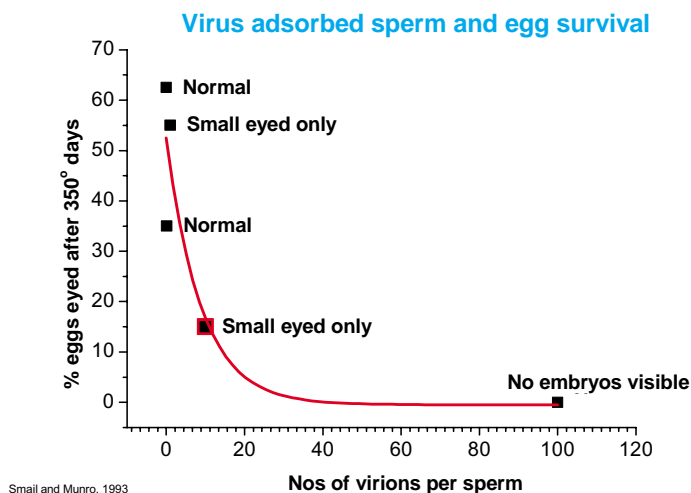

Figure 1. The relationship between virus titre, expressed as virions per sperm and egg survival, expressed as % eggs eyed after 350° days.

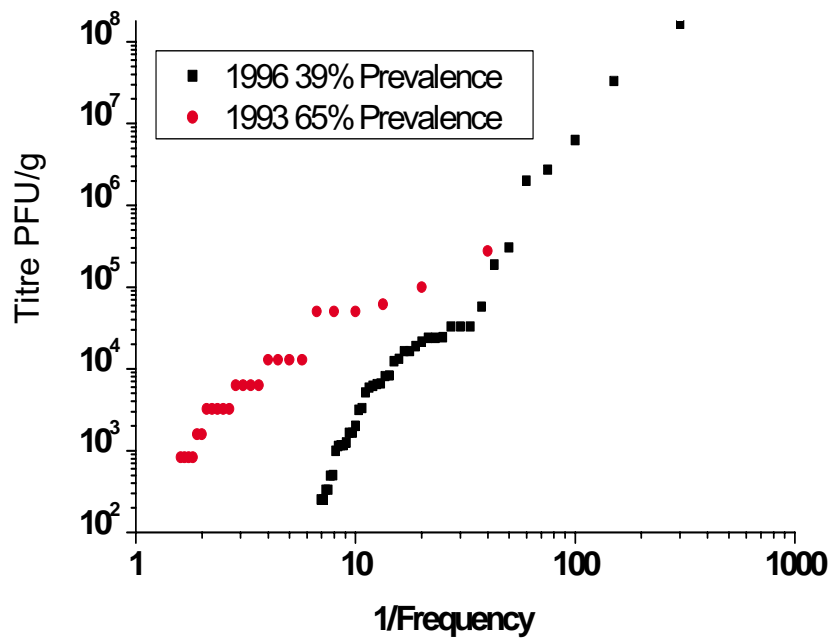

Figure 2. Virus titres from kidney in carrier populations of Atlantic salmon broodfish.

Although there is little experimental data on vertical transmission of IPNV in Atlantic salmon, comparing the proportion of IPN disease outbreaks in freshwater hatcheries from Norway and Scotland provides some circumstantial evidence for this transmission route. The approach to managing IPN is different in the two countries, IPN has effectively been deregulated and there is a general lack of broodstock testing in Norway (Taksdal 2002) (*see also 1.3.*). In contrast, in Scotland regular inspections for IPN are carried out and all salmon farms holding broodstock are inspected twice and sampled once per year (Anon 2002). If broodfish are diagnosed IPN positive in Scotland gametes from infected fish are destroyed. When disease outbreaks in freshwater hatcheries from the two countries are compared, viral prevalence in Scotland is less than half that of Norway and only a fraction of these cases may result in disease outbreaks. It seems, unless there is a natural reservoir in Norway or biosecurity differs markedly, that the removal of potentially infected gametes does result in a lower number of IPN disease incidences. This does suggest that vertical transmission occurs in Atlantic salmon.

The majority of studies published to date have failed to conclusively demonstrate vertical transmission of IPNV in salmonids. Those that have reported evidence (Bullock et al 1976; Wolf et al 1968; Bootland et al 1991) have done so using very small numbers of broodstock crosses insufficient for any statistical analyses. It appears vertical transmission is highly unpredictable and has a low probability of being observed under laboratory conditions (Mulcahy & Pascho 1985; Bootland et al 1991).

Clearly, future work should focus on establishing conclusively whether or not IPNV is vertically transmitted in Atlantic salmon. Experiments should be designed to overcome difficulties already encountered, particularly from a statistical point of view. To provide reliable data, such experiments would have to involve a large number of broodstock crosses of virus-free, virus carrier and virus-injected fish and a wide variety of diagnostic techniques to maximise the probability of detecting IPNV in progeny fry. To date, cell culture has been the preferred method for detecting IPNV in progeny fry. Whilst it is very

important to obtain titres of virus, molecular techniques offer greater sensitivity. PCR has proven a very important diagnostic method for the detection of ISAV (Mjaaland et al 1997; Rimstad et al 1999; Devold et al 2000; Snow et al 2003) and in situ hybridisation enables virus to be localised within cells and tissues. This latter technique could prove invaluable in understanding the localisation of virus within infected eggs and has already been developed to detect IPNV in yolk-sac fry (Biering & Bergh 1997).

A technically more demanding study may involve the use of recombinant virus to track virus from sexual fluids to fry. If, the firefly luciferase gene for example, could be introduced into the IPNV genome, luciferase activity could be monitored in eggs and fry infected with the recombinant virus. This technique has been successfully used to demonstrate that nuclear polyhedrosis virus can vertically transmit foreign genes in the silkworm, *Bombyx mori*, by detection of luciferase activity in larvae and pupae (Mori et al 1995). Nuclear polyhedrosis virus is a DNA virus, however a recombinant negative stranded RNA virus, Sendai virus, that can express the luciferase gene has been created (Hasan et al 1997), indicating the technology may be applicable to IPNV.

There is a need to obtain a greater understanding of the association of IPNV and sperm since it by this route that virus is most likely internalised within eggs (Mulcahy and Pascho, 1984). The study of Mulcahy and Pascho was simple yet very informative. Two closely related rhabdoviruses, IHNV and VHSV, exhibited significant variation in their adsorption to sperm. IHNV, which is vertically transmitted, adsorbed to sperm whereas VHSV, which is not transmitted vertically, did not. In the same study, adsorption of IPNV to sperm was demonstrated in trout (Mulcahy and Pascho, 1984). For *A. salmon*, Smail & Munro (1989) did demonstrate that IPNV can adsorb to sperm, however, only one virion per sperm was adsorbed which would make 'downstream' detection of IPNV in egg and embryo very difficult. Virus levels are likely to be well below the limit of detection of the methods used in the study by Smail & Munro (1989). These authors indicated that it would be interesting to examine the effects of viral concentrations of greater than one virion per sperm and given the other evidence (Wolf *et al.*, 1963; Dorson and Torchy, 1985; Bootland *et al.*, 1991; Bootland *et al.*, 1995; FRS unpublished data) of a relationship between successful vertical transmission and virus titre, it is essential to examine more closely virus titre dependent effects to determine the threshold of infection in Atlantic salmon and support the hypothesis that vertical transmission is titre dependent.

### 3.2. Horizontal transmission of IPNV

Horizontal transmission of IPN can be defined as the lateral spread of IPN virus and involves virus transmission in and between the freshwater and marine environments by a variety of reservoirs and vectors. In the context of transmission, a vector can be defined as any intermediate or alternative living or inanimate agent that transmits a pathogen to a susceptible host. A reservoir can carry a pathogen and remain unharmed whilst acting as a potential source of infection. To gain a thorough understanding of IPNV horizontal transmission it is essential to determine reservoirs and vectors to elucidate the dynamics of infection in the aquatic environment. It is likely that virus can travel from the primary host (eg salmon or trout) to the various reservoirs and vectors of infection and vice versa. Potential reservoirs of IPNV include farmed fish, wild fish, species cohabiting with farmed fish, sediments under fish farm cages, ectoparasites, shellfish, plankton, crustaceans, birds and mammals.

To date IPNV has been isolated from water, sediment, birds, shellfish and farmed, cohabiting and wild fish ([www.collabcen.net/toWeb/aq2.asp](http://www.collabcen.net/toWeb/aq2.asp); Rivas et al 1993; Hill & Way 1995; Reno et al 1999). Whilst the identification of reservoirs is essential, it is very important to elucidate the role such reservoirs play in the transmission of IPNV since it is apparent that some reservoirs are more likely to act as vectors than others. It is also essential to accurately identify strains of IPNV from reservoirs since there are a wide range of birnaviruses many of which may be found in the environment but which may pose no risk to salmonids. Serogroup A aquatic birnaviruses pose the greatest risk to salmonid fish and cause infectious pancreatic necrosis, IPN (Hill & Way 1995), although there is some evidence that serogroup B can also cause IPN in salmonids (Ahne et al 1989; Biering 1999) (2.3.1.). The following discussion will indicate reservoirs and vectors that have already been identified and highlight areas of research that are inadequate at present.

### 3.3. Reservoirs

#### 3.3.1. Farmed fish

Farmed fish may be the most important reservoir of IPN virus in the aquatic environment. During an epizootic of IPN, virus is shed with faeces and urine (Billi & Wolf 1969; Wolf et al 1968) and from dead and moribund fish into the waters around the farm (4.2.3. and 5.1.2.3.). IPN the disease has mainly been a problem in first feeding fry (Wolf et al 1960; Vestergaard & Jorgensen 1974; Krogsrud et al 1989), however in recent years the disease has been associated with seawater transfer of Atlantic salmon (Smail et al 1992; Jarpe et al 1995; Bowden et al 2002). The emerging scenario from experimental work is that healthy smolts are very susceptible to IPN virus if challenged within six weeks of seawater transfer (Bowden *et al.*, 2002). In the cage environment secondary infections such as *Vibrio* may serve to weaken host defences and further compromise the health of post-smolts. A significant characteristic of the disease is that high proportions of fish develop a lifelong persistent infection, *i.e.* a carrier state (Wolf et al 1963; Yamamoto 1975; Fenner et al 1974; Bootland et al 1991) (Ch 5).

The importance of carrier fish as reservoirs and vectors will depend upon the rate and quantity of virus that is shed and whether or not this is equivalent to minimum infective dose for salmonid fish. Asymptomatic carriers of IPNV are known to periodically shed infectious virus in faeces and reproductive products (Hill 1982). Infected post-smolts may shed low amounts of virus via the faeces up to six weeks after bathing infection and up to eight weeks after feeding infection (Smail, unpublished data). Bootland et al (1991) measured shedding from faeces of ip infected Brook trout over a 76 week period and found a significant decrease in both the number of faecal shedders and in the mean faecal titre over time. However, although there was a decrease when week 8 and 76 are compared, there was fluctuation in prevalence of

...it is difficult to conclude that faecal shedding decreases over moment...

shedders and titres over time, therefore, it is difficult to conclude that faecal shedding decreases over time. This observation has important implications on the role of carriers in the horizontal transmission of IPNV. It is possible that significant quantities of virus may be shed several months after the carriers become infected. To establish an infection, IPNV would have to reach a minimum infectious dose. Calculations based on the study by Bootland et al (1991) suggest that faecal shedding rates could reach approximately  $10^5$  TCID<sub>50</sub>fish<sup>-1</sup>. Bowden et al (2002) demonstrated that a dose of  $10^5$  TCID<sub>50</sub>fish<sup>-1</sup> produced approximately 60 % mortality in ip-injected fish and 30 % in cohabitees. This evidence



highlights the significance of carrier fish as a vector in the horizontal transmission of IPNV.

Clearly, further research is needed to better establish shedding rates of IPNV from salmonids, particularly directly into the water column, via urine and other secretions, since this area has been overlooked in the effort to quantify faecal shedding. This could be done experimentally, however, collection of field data following an outbreak is essential to support any laboratory-based findings. The study by Bowden et al 2002 represents the first challenge model for *A. salmon* smolts using a relatively natural route of infection by cohabitation. However, a more realistic challenge model is immersion challenge. Although this has been successfully demonstrated in juvenile salmonids (Smail et al 1986; Taksdal et al 1997), it has not yet been established in adult salmon. The mechanisms involved in the variation in shedding from carriers needs to be determined, particularly with respect to the problems encountered after the seawater transfer of *A. salmon*, in particular the role of stress on shedding from carrier fish is important to establish.

In a fish-farming environment, the activities of staff are also likely to be important in the transmission of IPNV. They are likely to be mechanical vectors rather than true carriers. Fish farm equipment that comes into contact with fish, such as hand nets, grading machinery, harvest bins and mortality containers, pose a risk of the transmission of disease if they are transferred between tanks, ponds or cages or between fish farms. The transporting of fish and the equipment associated with this activity, such as vehicles, wellboats (Murray *et al.*, 2002) and other vessels, also pose a significant risk. Other fish farm activities, such as harvesting and processing of fish, can lead to the spread of disease if risk reduction methods are not employed. Equipment used to remove or transport dead fish poses a high risk of transferring IPN virus to healthy fish. Good husbandry and management practice, employing methods of disease prevention and control that are known to be effective against other diseases, are likely to be effective in the prevention and control of IPN infection. An assessment of risk factors in disease transmission in the fish farming has been done successfully for ISA using case control studies (Jarp & Karlsen 1997) and a more qualitative approach (Munro et al 2003). These types of study, employing classical epidemiological investigations, particularly case control studies are essential to understand more about IPNV transmission (4.2.).

Even with good levels of containment, it is possible that some fish will escape at some time from commercial fish farms. The role of escapees



involves a number of factors; the likelihood of an escape event occurring on an infected farm; the level of IPN virus infection on the farm; the level of clinical disease present on the farm and the dispersal of escaped fish in relation to susceptible wild and farmed fish populations. It is considered that escaped fish that are suffering from clinical disease are likely to be more susceptible to predation than healthy carriers. By virtue of their weakened condition, fish that are suffering from clinical disease will not be likely to survive and travel as great a distance as healthy carriers. In a three-year study of the distribution and prevalence of IPN virus in wild fish in a Scottish fresh water loch, there was evidence that wild adult brown trout and perch may have become infected by feeding on rainbow trout that had escaped from a nearby farm (Munro *et al.*, 1976). The greatest risk of IPN transmission from escapees is from those that are asymptomatic carriers of the virus. IPNV has been isolated from escapee Atlantic salmon in Scottish rivers (FRS unpub data) however; the prevalence of both escapees and those that are carriers of IPNV is unknown. Extensive surveys to



establish IPNV prevalence in escapees are essential. However, this must be performed alongside a comprehensive analysis of the numbers and disease status of farm escapees to determine the risk such fish pose to wild fish and other farmed fish stocks.

### 3.3.2. Wild fish

IPNV has been isolated from numerous fresh water and marine fish species (Reno, 1999). Many isolations have been from farmed fish, or from wild fish in the vicinity of infected farms, including saithe, pollack and hake in the vicinity of a marine salmon farm in Shetland (FRS, unpublished data). Evidence of IPN virus infection has also been detected in wild salmonid fish where there was no known contact with hatchery-reared fish (FRS, unpublished data), however, the level of virus shedding from wild salmonid fish is

...a recent survey indicated extremely low prevalence of IPNV in wild fish...

unknown. A comprehensive study was carried out on the distribution and prevalence of IPN virus in wild fish, principally mature brown trout, in Loch Awe (Munro *et al.*, 1976). After an IPN outbreak at a Loch

Awe rainbow trout farm in 1971, further epizootics occurred from 1972-75. In the nearby loch, IPN virus was detected in salmonid and non-salmonid fish but the low prevalence (range 0.2-2.5% for both) and the absence of detection after 1977 indicated that the infection was not enzootic in the wild fish in the loch. IPN virus was, therefore, not self-sustaining as a natural infection in the wild fishery in the absence of the source of virus from the rainbow trout farm. A recent wild fish survey of 1642 freshwater and 7297 marine fish also indicated extremely low prevalence of IPNV in wild fish of 0.2% in freshwater salmonids and 0.01% in marine fish (FRS unpub data). This lends support to the hypothesis that IPN may not be self-sustaining as a natural infection in wild fish (4.1.1).



The continuation and development of wild fish surveys is critical in obtaining comprehensive temporal and geographic data on the prevalence of IPNV in wild fish. In addition, phylogenetic analysis of IPNV isolates obtained from wild and farmed fish will be invaluable in understanding the origins and evolution of IPNV. Preliminary analysis of a small number of Scottish wild isolates to date has already identified an isolate that is genetically distinct from any Scottish farmed isolates analysed to date (FRS unpub data). Given the wide genetic variation reported within serogroup A birnaviruses (Blake *et al* 2001) and evidence that serogroup B may be endemic in the North Sea close to Denmark (Skall *et al* 2000) it will be essential to perform virulence tests to determine whether isolates obtained from wild fish pose a disease risk to farmed Atlantic salmon.

### 3.3.3. Water

Water-borne transmission of fish pathogens is likely to be a significant route of horizontal transmission. It is recognised that farms stocked with fish suffering from IPN, or carrying IPN virus, shed virus particles into the water (Table 1).

Table 1. Measurements of IPN virus levels in water holding IPN virus-infected rainbow trout

PFU/ml*	Comments	Reference	Virus transmitted to uninfected fish
10 <sup>5</sup>	Experimental infection	Dorson & Torchy, 1981	Yes
10 <sup>4</sup>	Hatchery effluent	Munro et al. 1976	Likely
10 <sup>1</sup>	Hatchery effluent	McAllister & Bebak (1997)	Unknown
10 <sup>-1</sup>	Downstream effluent	McAllister & Bebak (1997)	Unknown

\*PFU/ml = plaque forming units/ml

Rainbow trout hatchery effluent virus levels have been measured at 10 pfu/ml (McAllister and Bebak, 1997) to 10<sup>4</sup> pfu/ml (Munro *et al.*, 1976). Concentrations of IPN virus of 10<sup>-1</sup> pfu/ml water have been reported downstream of IPN infected rainbow trout hatcheries (McAllister and Bebak, 1997). In an experimental situation, these ranges of titres have induced mortalities in cohabiting salmon (Bowden et al 2002) (4.2.1.).

The survival of waterborne viruses in the aquatic environment is very important since they must retain their infectivity long enough to reach and infect a susceptible host. Survival of IPN virus in untreated fresh, estuarine and seawater was reported as long-lived with an inactivation profile of approximately 3 log<sub>10</sub> over three weeks (Toranzo and Hetrick, 1982), equivalent to a 10-fold reduction per week at 15°C. Survival of IPN virus outside the host is longer at lower temperatures. This relationship is also evident under laboratory conditions; IPN virus survived for 147 days in Tris-glycine acid buffer, pH 3.8 at 4 °C but was undetectable at 71 days at 20 °C (Smail et al 1993) (*annex II*).

Survival data of this nature is very informative, however, care must be taken in the interpretation of results since survival in the natural environment will depend on local conditions. There are a number of factors that affect survival of viruses in aquatic environments that include presence of virucidal organisms (Fujioka et al 1980); heavy metals (Bitton 1980); binding to non-living particles causing sedimentation (Metcalf et al 1974; Murray and Jackson 1992); UV (Harm 1980; Suttle and Chen 1992) and temperature (Barja et al 1983; Toranzo and Hetrick 1982). Of particular interest in the fish farming environment is the role of particulate organic matter in virus survival. There are conflicting view points on this issue with some authors reporting a protective effect of organic particulates on virus stability (Mitchell 1971; Gerba & Schaiberger 1975), others observing higher inactivation rates in more polluted waters (Shuval et al 1971; Fujioka et al 1980), while Smith et al 1978 found virus survival to be independent of the degree of pollution. In terms of fish pathogens, Yoshinaka et al (2000) reported that IHNV adsorbed to a variety of solids and ISAV is readily adsorbed to clay and sand (FRS unpublished). It is essential to understand which factors significantly affect survival of IPNV in the aquatic environment for epizootiological studies. A combination of field and laboratory based investigations represent the best approach. In the laboratory, differences in adsorption to organic and inorganic suspended particles and rates of sedimentation should be examined. From the field, water samples should be collected during and after an IPN outbreak at various distances and depths from the source of infection. The physical and biological properties of water samples should be measured in conjunction with IPNV viral load to understand the relationship between survival and conditions in the aquatic environment.

### 3.3.4. Sediments

Rivas et al (1993) successfully reported the isolation of birnavirus from sediments collected in the water intake and/or water outlet of fish farms. Although the isolates were neutralised most strongly with the Sp reference strain of IPNV, there are many cross-reacting serotypes among isolates from salmonid and non-salmonid fish and marine invertebrates (Caswell-Reno et al 1989; Lipipun et al 1992). It would be essential to genetically characterise these isolates to confirm if they were of farmed origin. Clearly, a great deal of work is needed to determine the prevalence, persistence and, importantly, release of IPNV from sediments. Microcosm studies in the laboratory offer the opportunity to study survival and perhaps release from sediments in a controlled environment. Such experiments used in conjunction with isolations from field samples will establish the role of sediments in the horizontal transmission of IPNV.

### 3.3.5. Invertebrates

IPNV is a member of the aquatic birnaviruses, a very diverse group of viruses which infect many invertebrates as well as vertebrates. The role of invertebrates in the transmission of IPNV is not well understood. Invertebrate hosts of IPNV identified to date are reviewed and summarised in Reno (1999). Those that pose a risk in transmission of IPNV can be separated into 3 groups in terms of horizontal transmission, parasites such as sea lice, planktonic organisms including rotifers and benthic or sedentary organisms including shellfish and crustaceans. It is important to emphasise the need for a reliable classification system for aquatic birnaviruses since it is likely that some invertebrates will be infected by birnaviruses that pose no risk to salmonid fish (2.3.). At present the classification system is largely serologically based however there are many cross-reacting serotypes among isolates from salmonid and non-salmonid fish and marine invertebrates (Caswell-Reno et al 1989; Lipipun et al 1992). A genetic classification is likely to be more informative, Blake et al (2001) analysed the VP2 gene from a number of aquatic birnaviruses, all within serogroup A and identified 6 genogroups within this serogroup. Research should focus on strains of IPNV that have both invertebrates and fish as hosts because these pose the greatest risk to salmonid fish.

In terms of parasites, there are no reports in the literature on the potential of sea lice or other ectoparasites to transmit IPNV. Both *Lepeophtheirus salmonis* and *Caligus elongatus* have, however, been shown to transmit infectious salmon anaemia (Nylund et al., 1993 and Nylund et al., 1994). IPNV has been found in blood leucocytes (Swanson and Gillespie 1982) and since Sea lice ingest blood cells as they graze on the fish skin, there is a potential to take up IPNV. In addition, it has been demonstrated that pre-adult and adult stages of *L. salmonis* move from host to host (Jakobsen 1993), and that well-fed adults of *C. elongatus* may leave the host and live in the plankton, later to attack other fish (Kaestner 1970). It does appear sea lice may pose a significant risk in the farmed environment when heavy lice infestations arise. Experimental work is required to determine whether sea lice can transmit IPNV from infected fish to naïve fish. Also there is a need to determine whether lice carry significant titres of IPNV.

...no reports on the potential of sea lice to transmit IPNV... it does appear sea lice may pose a significant risk...

The ability of planktonic organisms, such as rotifers (*Brachionus plicatilis*), to harbour IPN-like virus may be significant as these organisms are widely used in the culture of juvenile pre-weaned marine species some of which (eg halibut and cod) are susceptible to IPN virus (Mortensen et al., 1990). However, it is not known if rotifers can carry IPN

virus virulent to halibut. Comps *et al.*, (1991) concluded that the rotifer birnavirus showed unique biophysical and biochemical characteristics within the birnavirus group. To date, this virus has not been typed serologically or genetically and its risk to salmonid fish is unknown.

IPNV has been isolated from shellfish and crustaceans, reviewed in Reno (1999). Mortensen (1993) isolated IPN virus from the faeces and pseudofaeces of scallops (*Pecten maximus*) and from prawns (*Pandalus borealis* and *Palaemon elegans*), which grazed on dead IPN virus-contaminated scallops. However, it is not known whether such hosts can actually replicate IPNV or whether they act as passive carriers. The presence or abundance of carrier shellfish in the vicinity may influence the risks to marine cage sites. Studies on the freshwater crayfish have shown that not only can the virus still be isolated from this animal one year after the original infection, but also that IPNV is excreted into the water continuously (Halder and Ahne 1988). This virus shedding was demonstrated to cause subsequent infection in cohabiting rainbow trout fry. Clearly with such a wide range of potential host species the capacity for IPN to be sustained in both the marine and freshwater environment is considerable. Research is required to ascertain if wild crustaceans and molluscs acquire IPNV from infected salmon populations, whether IPNV can replicate in any invertebrates and whether virus released can induce infection in salmonid fish.



### 3.3.6. Birds

Birds are regular and persistent visitors to aquatic installations and there have been some investigations into their role as vectors of aquatic pathogens. It has been shown for example that piscivorous birds including corvids, herons and kingfishers preying on rainbow trout fry infected with IPNV can excrete live IPN virus in their faeces, (McAllister and Owens, 1992). These authors suggest that this represents a significant risk of virus transmission. IPNV has also been isolated from blackheaded gulls (*Larus ridibundus*) (Eskildsen and Vestergard-Jorgensen, 1973). All birds that frequent fish farms should be considered as potential risks for the transfer of disease. Research to improve knowledge of the prevalence of IPN virus among seabirds where IPN is enzootic would help in the understanding of the epizootiology of the disease.

### 3.3.7. Mammals

Predators and scavengers that frequent fish farms have potential to act as vectors of infection. IPN virus has been shown to survive passage through the gastro-intestinal tract of mink fed IPN virus-infected fish (Sonstegard *et al.*, 1972). Smail *et al.*, (1993) passaged IPN virus through the gut of cows in an attempt to assess the suitability of IPN virus-containing fish silage as an animal feed. IPN virus was detectable in cattle faeces 24 and 72 hours after feeding but not after four days. This demonstrates the ability of the virus to survive passage through the mammalian gut. Apart from this work there is limited detailed published material regarding mammals as vectors of IPN virus. Other mammals that interact with fish farms include rodents, mink, otters, seals and cetaceans. Humans should be regarded as mechanical vectors but are unlikely to be true carriers. Knowledge of the prevalence of IPN virus among mammals where IPN is enzootic would help in the understanding of the epizootiology of the disease.

### 3.4. References

1. Ahne, W., Negele, R.D., 1985. Studies on the transmission of infectious pancreatic necrosis virus via eyed eggs and sexual products of salmonid fish. In: Ellis, A.E. (Ed.), *Fish and Shellfish Pathology*. Academic Press, London, pp. 262-270.
2. Ahne, W., Kelly, R.K., Schlotfeldt, 1989. Factors affecting the transmission and outbreak of infectious pancreatic necrosis (IPN). In: Lillelund, K., Rosenthal, H. (Eds.), *Fish Health Protection Strategies*. Federal Ministry for Research and Technology, Hamburg/Bonn, pp. 19-67.
3. Ahne, W., Jorgensen, P.E.V., Olesen, N.J., Fischer-Scherl, T., Hoffman, R., 1989. Aquatic birnaviruses: Virus of the serogroup II isolated from an IPN outbreak in brook trout (*Salvelinus fontinalis*). *Bulletin of the European Association of Fish Pathologists* 9, 14-16.
4. Anon, 2002. Report of the Aquaculture Health Joint Working Group Sub-group on infectious pancreatic necrosis in Scotland.
5. Barja, J.L., Toranzo, A.E., Lemos, M.L., Hetrick, F.M., 1983. Influence of water temperature and salinity on the survival of IPN and IHN viruses. *Bulletin of the European Association of Fish Pathologists* 3, 47-50.
6. Biering, E., 1999. *Infeksio/s pankreasnekrose, Fiskehekse og fiskesykdommer*. Universitetsforlaget AS, Oslo.
7. Biering, E., Bergh, O., 1996. Experimental infection of Atlantic halibut, *Hippoglossus hippoglossus* L., yolk-sac larvae with infectious pancreatic virus: detection of virus by immunohistochemistry and in situ hybridization. *Journal of Fish Diseases* 19, 261-269.
8. Billi, J.L., Wolf, K., 1969. Quantitative comparison of peritoneal washes and faeces for detecting infectious pancreatic necrosis (IPN) in carrier brook trout. *Journal of the Fisheries Research Board of Canada* 26, 1459-1465.
9. Bitton, G., 1980. *Introduction to environmental virology*. Wiley-Interscience, New York.
10. Blake, S., Ma, J.-Y., Caporale, D.A., Jairath, S., Nicholson, B.L., 2001. Phylogenetic relationships of aquatic birnaviruses based on deduced amino acid sequences of genome segment A cDNA. *Diseases of Aquatic Organisms* 45, 89-102.
11. Bootland, L.M., Dobos, P., Stevenson, R.M.W., 1991. The IPNV carrier state and demonstration of vertical transmission in experimentally infected brook trout. *Diseases of Aquatic Organisms* 10, 13-21.
12. Bootland, L.M., Dobos, P., Stevenson, R.M.W., 1995. Immunisation of adult brook trout (*Salvelinus fontinalis*) (Mitchill) fails to prevent the infectious pancreatic necrosis virus (IPNV) carrier state. *Journal of Fish Diseases* 18, 449-458.
13. Bowden, T.J., Smail, D.A., Ellis, A.E., 2002. Development of a reproducible infectious pancreatic necrosis virus challenge model for Atlantic salmon, *Salmo salar* L.
14. Bullock, G.L., Rucker, R.R., Amend, D., Wolf, K., Stuckey, H.M., 1976. Infectious pancreatic necrosis: transmission with iodine-treated and nontreated eggs of brook trout (*Salvelinus fontinalis*). *Journal of the Fisheries Research Board of Canada* 33, 1197-1198.
15. Caswell-Reno, P., Lipipun, V., Reno, P.W., Nicholson, B.L., 1989. Utilization of a group of reactive and other monoclonal.
16. Comps, M., Mari, J., Poisson, F., Bonami, J.-R., 1991. Biophysical and biochemical properties of an unusual birnavirus pathogenic for rotifers. *Journal of General Virology* 72, 1229-1236.
17. Devold, M., Krossoy, B., Aspehaug, V., Nylund, A., 2000. Use of RT-PCR for diagnosis of infectious salmon anaemia virus (ISAV) in carrier sea trout *Salmo trutta* after experimental infection. *Diseases of Aquatic Organisms* 40, 9-18.
18. Dorson, M., C, T., 1985. Experimental transmission of infectious pancreatic necrosis virus via the sexual products. In: Ellis, A.E. (Ed.), *Fish and Shellfish Pathology*. Academic Press, London, pp. 251-260.
19. Eskildsen, U.K., Vestergard-Jorgensen, P.E., 1973. On the possible transfer of gut pathogenic viruses by gulls. *Riv. Ital. Piscicoltura. Ittiopatol.* 8, 104-105.
20. Fujioka, R.S., Loh, P.C., Lau, S.L., 1980. Survival of human enteroviruses in the Hawaiian ocean environment: evidence for virus inactivation by microorganisms. *Applied and Environmental Microbiology* 39, 1105-1110.
21. Gerba, C.P., Schaiberger, G.E., 1975. Effect of particulates on virus survival in seawater. *Journal of the Water Pollution and Control Federation* 47, 93-103.
22. Halder, M., Ahne, W., 1988. Freshwater crayfish *Astacus astacus* - a vector for infectious pancreatic necrosis. *Diseases of Aquatic Organisms* 4, 205-209.
23. Harm, W., 1980. *Biological effects of ultraviolet radiation*. Cambridge University Press, Cambridge.
24. Hasan, M.K., Kato, A., Shioda, T., Sakai, Y., Yu, D.S., Nagai, Y., 1997. Creation of an infectious recombinant Sendai virus expressing the firefly luciferase gene from the 3' proximal first locus. *Journal of General Virology* 78, 2813-2820.



25. Hill, B.J., 1982. Infectious pancreatic necrosis virus and its virulence. In: Roberts, R.J. (Ed.), *Microbial Diseases of Fish*, pp. 91-114.
26. Hill, B. J. 2001 International Database on Aquatic Animal Diseases. Department of Environment, Food and Rural Affairs (defra) UK. CEFAS Weymouth Laboratory, Weymouth, UK.  
[www.collabcen.net/toWeb/aq2.asp](http://www.collabcen.net/toWeb/aq2.asp)
27. Hill, B.J., Way, K., 1995. Serological classification of infectious pancreatic necrosis (IPN) virus and other aquatic birnaviruses. *Annual Review of Fish Diseases* 5, 55-77.
28. Jakobsen, P., 1993. Lice infestation of wild salmonid populations in Norway. In: Meldon, J. (Ed.), *Aquaculture in Ireland - towards sustainability*. An Taisce Publication, Dublin, pp. 75-76.
29. Jarp, J., Karlsen, E., 1997. Infectious salmon anaemia (ISA) risk factors in sea-cultured Atlantic salmon. *Diseases of Aquatic Organisms* 28, 79-86.
30. Jarp, J., Taksdal, T., Torud, B., 1996. Infectious pancreatic necrosis in Atlantic salmon, *Salmo salar*, in relation to specific antibodies, smoltification and infection with erythrocytic inclusion body syndrome EIBS. *Diseases of Aquatic Organisms* 27, 81-88.
31. Jarp, J., Gjevne, A.G., Olsen, A.B., Bruheim, T., 1995. Risk factors for furunculosis, infectious pancreatic necrosis and mortality in post-smolts of Atlantic salmon, *Salmo salar* L. *Journal of Fish Diseases* 18, 67-78.
32. Kaestner, A., 1970. *Invertebrate Zoology. Crustacea. Volume 3*. Interscience Publishers, New York.
33. Krogsrud, J., Hastein, T., Ronningen, K., 1989. Infectious pancreatic necrosis virus in Norwegian fish farms. In: Ahne, W., Kurstak, E. (Eds.), *Viruses of Lower Vertebrates*. Springer, Berlin, pp. 284-291.
34. Lipipun, V., Caswell-Reno, P., Reno, P.W., Nicholson, B.L., Hsu, Y.-L., Wu, J.-L., 1992. Antigenic variation of aquatic birnaviruses. In: Shariff, M., Subasinghe, R.P., Arthur, J.R. (Eds.), *Diseases in Asian Aquaculture*. Fish Health Section. Asian Fish Society, Manila, Philippines, pp. 237-245.
35. Martin, W.S., Meeks, A.H., Willeberg, P., 1987. *Veterinary Epidemiology. Principles and Methods*. Iowa State University Press, Ames, 343 pp.
36. McAllister, P.E., Owens, W.J., 1992. Recovery of infectious pancreatic necrosis from the faeces of wild infectious piscivorous birds. *Aquaculture* 106, 227-232.
37. McAllister, P.E., Bebak, J., 1997. Infectious pancreatic necrosis virus in the environment: relationship to effluent from aquaculture facilities. *Journal of Fish Diseases* 20, 201-207.
38. Metcalfe, T.G., Walis, C., Melnick, J.L., 1974. Virus enumeration and public health assessments in polluted surface water contributions to transmission of virus in nature. In: Malin, J.F., Sagik, B.P. (Eds.), *Virus survival in water and wastewater systems*. University of Texas, Austin, pp. 57-70.
39. Mitchell, R., 1971. Destruction of bacteria and viruses in seawater. *Journal of the Sanitary Engineering Division* 97, 425-432.
40. Mjaaland, S., Rimstad, E., Falk, K., Dannevig, B.H., 1997. Genomic characterization of the virus causing infectious salmon anemia in Atlantic salmon (*Salmo salar* L.): an orthomyxo-like virus in a teleost. *Journal of Virology* 71, 7681-7686.
41. Mori, H., Yamao, M., Nakazawa, H., Sugahara, Y., Shirai, N., Matsubara, F., Sumida, M., Imamura, T., 1995. Transovarian transmission of a foreign gene in the silkworm, *Bombyx mori*, by *Autographa californica* nuclear polyhedrosis virus. *Biotechnology* 13, 1005-1007.
42. Mortensen, S.H., 1993. Passage of infectious pancreatic necrosis virus (IPN virus) through invertebrates in an aquatic food chain. *Diseases of Aquatic Organisms* 16, 41-45.
43. Mortensen, S.H., Hjeltnes, B., Rodseth, O., Krogsrud, J., Christie, K.E., 1990. Infectious pancreatic necrosis virus, serotype N1, isolated from Norwegian halibut (*Hippoglossus hippoglossus*), turbot (*Scophthalmus maximus*) and scallops (*Pecten maximus*). *Bulletin of the European Association of Fish Pathologists* 10, 42-43.
44. Mulcahy, D., Pascho, R.J., 1984. Adsorption of fish sperm to vertically transmitted fish viruses. *Science* 225, 333-335.
45. Munro, A.L.S., Liversidge, J., Elson, K.G.R., 1976. The distribution and prevalence of infectious pancreatic necrosis virus in wild fish in Loch Awe. *Proceedings of the Royal Society of Edinburgh (B)* 75, 221-232.
46. Munro, P.D., Murray, A.G., Fraser, D.I., Peeler, E.J., 2003. An evaluation of the relative risks of infectious salmon anaemia transmission associated with different salmon harvesting methods in Scotland. *Ocean and Coastal Management* 46, 157-173.
47. Murray, A.G., A, J.G., 1992. Viral dynamics: a model of the effects of size, shape, motion and abundance of single-celled planktonic organisms and other particles. *Marine Ecology Progress Series* 89, 103-116.
48. Murray, A.G., Smith, R.J., Stagg, R.M., 2002. Shipping and the spread of infectious salmon anemia in Scottish aquaculture. *Emerg Infect Dis* 8, 1-5.



49. Nylund, A., Wallace, C., Hovland, T., 1993. The possible role of *Lepeophtheirus salmonis* (Kroyer) in the transmission of infectious salmon anaemia. In: Boxshal, G.A., Defaye, D. (Eds.), *Pathogens of Wild and Farmed Fish*. Ellis Horwood Ltd, New York, pp. 367-373.
50. Nylund, A., Hovland, T., Hodneland, K., Nilsen, F., Lovik, P., 1994. Mechanisms of transmission of infectious salmon anaemia (ISA). *Diseases of Aquatic Organisms* 19, 95-100.
51. Reno, P.W., 1999. Infectious pancreatic necrosis and associated aquatic birnaviruses. In: Woo, P.T., Bruno, D.W. (Eds.), *Fish Diseases and Disorders, Volume 3: Viral, Bacterial and Fungal Infections*. CABI publishers, UK, pp. 1-55.
52. Rimstad, E., Falk, K., Mikalsen, A.B., A, T., 1999. Time course distribution of infectious salmon anaemia virus in experimentally infected Atlantic salmon *Salmo salar*. *Diseases of Aquatic Organisms* 36, 107-112.
53. Rimstad, E., Falk, K., Mikalsen, A.B., A, T., 1999. Time course distribution of infectious salmon anaemia virus in experimentally infected Atlantic salmon *Salmo salar*. *Diseases of Aquatic Organisms* 36, 107-112.
54. Rivas, C., Cepeda, C., Dopazo, C.P., Novoa, B., Noya, M., Barja, J.L., 1993. Marine environment as a reservoir of birnaviruses from poikilothermic animals. *Aquaculture* 115, 183-194.
55. Shuval, H.I., Asce, M., Thompson, A., Fattal, B., Cimbalista, S., Wiener, Y., 1971. Natural inactivation processes in seawater. *Journal of the Sanitary Engineering Division* 5, 587-600.
56. Skall, H.F., Mellergaard, S., Olesen, N.J., 2000. Isolation of Birnavirus serogroup B in wild and aquacultured fish species. *Bulletin of the European Association of Fish Pathologists* 20, 229-236.
57. Smail, D., Munro, A.L.S., 1989. Infectious pancreatic necrosis virus in Atlantic salmon: Transmission via the sexual products? In: Ahne, W., Kurstak, E. (Eds.), *Viruses of Lower Vertebrates*. Springer-Verlag, Berlin, pp. 292-301.
58. Smail, D.A., Grierson, R.J., Munro, A.L.S., 1986. Infectious pancreatic necrosis virus (IPNV) in Atlantic salmon: virulence studies and sub-clinical effects with respect to growth, smolting performance and condition. *International Council for the Exploration of the Sea ICES/CM/1986/F:8*.
59. Smail, D.A., Huntly, P.J., Munro, A.L.S., 1993. Fate of four fish pathogens after exposure to fish silage containing fish farm mortalities and conditions for the inactivation of infectious pancreatic necrosis virus. *Aquaculture* 113, 183-187.
60. Smail, D., Irwin, N., Harrison, D., Munro, A.L.S., 1995. Passage and survival of infectious pancreatic necrosis virus (IPN) in the cow's gut after feeding a silage mixture containing IPN virus. *Aquaculture* 113, 183-187.
61. Smail, D., Bruno, D.W., Dear, G., McFarlane, L.A., Ross, K., 1992. Infectious pancreatic necrosis (IPN) virus Sp serotype in farmed Atlantic salmon, *Salmo salar* L., post-smolts associated with mortality and clinical disease. *Journal of Fish Diseases* 15, 77-83.
62. Smith, E.M., Gerba, C.P., Melnick, J.L., 1978. Role of sediment in the persistence of enteroviruses in the estuarine environment. *Applied and Environmental Microbiology* 35, 685-694.
63. Snow, M., Raynard, R.S., Murray, A.G., Bruno, D.W., King, J.A., Grant, R., Bricknell, I.R., Bain, N., Gregory, A., 2003. An evaluation of current diagnostic tests for the detection of infectious salmon anaemia virus (ISAV) following experimental water-borne infection of Atlantic salmon, *Salmo salar* L. *Journal of Fish Diseases* 26, 135-145.
64. Sonstegard, R.A., McDermott, L.A., 1972. Epidemiological model for passive transfer of IPN virus by homeotherms. *Nature* 237, 104-105.
65. Suttle, C.A., Chen, F., 1992. Mechanisms and rates of decay of marine viruses in seawater. *Applied and Environmental Microbiology* 58, 3721-3729.
66. Swanson, R.N., Gillespie, J.H., 1982. Isolation of infectious pancreatic necrosis virus from the blood components of experimentally infected trout. *Canadian Journal of Fisheries and Aquatic Science* 39, 225-228.
67. Taksdal, T., Stangeland, K., Dannevig, B.H., 1997. Induction of infectious pancreatic necrosis (IPN) in Atlantic salmon *Salmo salar* and brook trout *Salvelinus fontinalis* by bath challenge of fry with infectious pancreatic necrosis (IPNV) serotype Sp. *Diseases of Aquatic Organisms* 28, 39-44.
68. Toranzo, A.E., Hetrick, F.M., 1982. Comparative stability of two salmonid viruses and poliovirus in fresh, estuarine and marine waters. *Journal of Fish Diseases* 5, 223-231.
69. Wolf, K., Quimby, M.C., Bradford, A.D., 1963. Egg-associated transmission of IPN virus of trouts. *Virology* 21, 317-321.
70. Wolf, K., Sniezko, S.F., Dunbar, C.E., Pyle, E.A., 1960. Nature of infectious pancreatic necrosis virus in trout. *Proceedings of the Society for Experimental Biology and Medicine* 104, 105-108.
71. Wolf, K., Quimby, M.C., Carlson, C.P., Bullock, G.L., 1968. Infectious pancreatic necrosis: Selection of virus-free stock from a population of carrier trout. *Journal of the Fisheries Research Board of Canada* 25, 383-391.

72. Wolf, K., Quimby, M.C., Carlson, C.P., Bullock, G.L., 1968. Infectious pancreatic necrosis: selection of virus free stock from a population of carrier trout. *Journal of the Fisheries Research Board of Canada* 25, 383-391.
73. Yamamoto, T., 1975. Frequency of detection and survival of infectious pancreatic necrosis virus in a carrier population of brook trout (*Salvelinus fontinalis*) in a lake. *Journal of the Fisheries Research Board of Canada* 32, 568-570.
74. Yoshinaka, T., Yoshimizu, M., Ezura, Y., 2000. Adsorption and infectivity of infectious hematopoietic necrosis virus (IHNV) with various solids. *Journal of Aquatic Animal Health* 12, 64-68.

## 4. Epidemiology

- IPNV is widespread throughout the Norwegian farmed salmon population. Carrier fish may be found in any farm or sea site. The frequency of IPN outbreaks varies in time (annually) and space. 40-70 % of all seawater sites experienced outbreaks in 1994 – 2000 in Norway. Although crude mortality may reach more than 90 %, average accumulated crude site mortality during outbreaks is 10 % – 20 %. Thirty to forty percent of the hatcheries experienced IPN outbreaks in the same time period. The impact of extensive IPN-vaccination is not known.
- There are regional differences, but these have not been explained by research.
- Prevalence studies show that Sp-serotype is most frequently isolated both from diseased and non-diseased fish. However, molecular techniques have revealed different IPNV variants within the Sp-serotype, showing different virulence capacity. These tools are necessary for a more precise characterization of IPNV and the distribution of different variants in the salmon (and marine fish) populations. They are vital for further understanding of IPN, risk factors and for implementing proper control measurements.
- IPNV may be introduced to a hatchery by eggs, fry, human, fomites, different animals, and water. No studies have evaluated the impacts of these possible introductory alternatives. IPNV group prevalence and within group prevalence seem to increase by time spent in the hatchery.
- IPNV is persistent once introduced into a hatchery. Buying fry, outbreaks in previous years, and specific lining of hatching tanks have been associated with increased risk of IPN outbreaks in fry.
- Mixing populations from several hatcheries, transportation method, and size of smolts at sea transfer are associated with increased risk of IPN outbreaks in seawater. Intensified rearing conditions in freshwater (superoxygenation, low water supply and high density) are shown to increase risk of IPN outbreaks in seawater. It is proposed that superoxygenation itself and the specific water chemistry in mixing zones between different water qualities may in general make fry and smolts more vulnerable to infectious agents such as IPNV.
- The possibility that IPNV could be a risk factor for other (emerging) infections should be investigated.
- Ongoing breeding programme to improve resistance to IPNV is promising. Lines of rainbow trout with stable, genetically transmittable resistance to a specific IPN- strain have been produced in Japan.



- Internationally published epidemiological studies on risk factors, causality and economy are few in numbers. This in spite of IPN being one of the most serious viral diseases in terms of its impact on Atlantic salmon.
- The dynamic nature of fish production is challenging for reliable data gathering and demand increased focus on prospective, longitudinal studies and tracing procedures.

Epidemiology is defined as “the study of the distribution and determinants of health-related states or events in specified populations, and the application of this study to control of health problems” (Last 2001). Epidemiology describes patterns of disease occurrence and spread, production losses and identifies factors that influence these patterns.

In spite of a broad understanding of the interaction between host, agent and environment, the pathogenic agent as the casual component has received the most interest when investigating fish diseases. However, the complexity of several fish diseases and the economic importance of aquaculture including Atlantic salmon farming demand a wider approach to most fish diseases to reveal components of importance for disease promotion. Epidemiological tools are well suited for investigating this complexity. Despite this potential, epidemiological studies are few in number and the techniques are poorly adapted (Crockford 1998, Thorburn 1999, Georgiadis 2001).

IPN-virus has been diagnosed in most, if not all, major salmonid-farming countries of North and South America, Europe and Asia except for Sweden who claims freedom for IPN based on a national survey (OIE, Ariel 2002). Originally known to cause high mortality in freshwater trout, the disease has emerged through the - 90s in salmon farming countries like Norway and Scotland as a complex disease and the most serious viral diseases in terms of its impact on Atlantic salmon (*Salmon salar*) production in the European Union (Ariel 2002, Murray 2003). In Norwegian salmon production annual losses at farm level due to IPN is estimated to approximately 100 millions NOK (Olsen 2002).

Available literature regarding occurrence of IPN /IPNV constitute a combination of non-peer reviewed reports and a few papers published in international journals. Information on risk factors is dominated by non-reviewed reports, abstracts, and lectures. Just a few of these studies are published in international journals. Jarpe (1998b, 1999) has given reviews of some aspects of epidemiological research in aquaculture in Norway.

#### 4.1. Descriptive epidemiology

*Emergence of IPN virus and IPN outbreaks in Norwegian salmon production through the 1990s have been documented by several studies. In national surveys outbreaks are seen annually in 40 – 70 % of all seawater sites (1994 - 2000) while the Mid-Norway region experienced an annual occurrence of 70 – 90 % from 1998 - 2001. IPNV prevalence in wild salmon seems to be low.*

*Average accumulated crude mortality during outbreaks is 10 % – 20 %. Thirty to forty percent of the hatcheries experience annually IPN outbreaks. IPNV prevalence at group level and within group, increased by time from fry stage to smolt stage. The reason for this is not clarified. All virus identifications are primarily based on culturing and serotyping. Molecular methods indicate that the IPNV situation is a lot more variable than the results so far have indicated. It is essential to reveal this variability and its implications. IPN vaccine was introduced in 1995. 65 % of all smolts were vaccinated in 2000 increasing to*

85 % in 2002 at national level. The effect of this high coverage on the IPN situation is not revealed. Specifically designed field studies should be performed to evaluate the vaccine efficacy.

#### 4.1.1. Occurrence of IPN-virus in wild salmon

Approximately 3000 wild salmon and trout stockfish from different rivers in Norway have been screened by cell cultivation for IPNV during the years 1991 – 2002, mostly as part of the Gene Bank Programme for Norwegian Atlantic salmon or through the "Fish health service for restocking hatcheries", both activities conducted by VESO Trondheim (Aunsmo 2003a, Skår 2000). In the first years, 30-40 rivers were tested annually. The number has later decreased to about 10 rivers a year. Some of the rivers have been tested two or more consecutive years. Number of samples from each river has varied from two to seventy-nine fish.

In 1991-92 IPNV-carriers were found in one third of the tested rivers while no infected fish were found in any of the rivers during the period 1995 – 1999. Two rivers were found positive in 2000 and one river in 2001. In 2002 two IPNV-positive fish were detected in one river, both classified by fish scale analysis as escaped farmed Atlantic salmon (Aunsmo 2003b). By use of the beta distribution-function, data from the programme can be used to estimate expected overall prevalence in wild salmon stock as shown in Table 1. The annual findings indicate that the IPNV prevalence in wild stock is low and the situation seems to have been little influenced by the high prevalence and increasing outbreak frequency in farmed fish experienced during the nineties. However, any further interaction between IPNV in farmed and wild salmon is difficult to elucidate using this material as no typing (serotyping or genotyping) was performed.

Table 1. Estimated prevalence (95% central range) of IPNV in wild salmon stockfish, using samples collected from different rivers in Norway from 1999-2002 (from Aunsmo 2003a). (Prevalence calculated by  $RiskBeta(s+1, n-s+1)$ , assuming sensitivity=1, specificity=1).

Year	Number of rivers tested	Samples (n)	Positives (s)	Prevalence (95% central range)
1999	11	128	0	0,02-2,8
2000	13	300	2	0,7-2,4
2001	9	105	1	1,0-5,0
2002	12	253	2*	0,5-5,5

\* Escapees from farmed salmon

#### 4.1.2. Occurrence of IPN-virus and outbreaks in sea farms

An increasing number of outbreaks in post-smolts associated with IPN-virus (IPNV) were reported through the second half of the 80s (Willumsen 1988, Bruheim 1991). Melby (1991) found that 63.7 % of 1939 individual post-smolts from 608 sea farms were positive for IPNV. This was an investigation including a total of 74.8 % of all licensed sea farms in Norway. IPNV-positive samples were found on 95 % of these farms. They concluded that all salmon sea farms in Norway harboured positive carriers, probably as a result of the open national market for smolt purchase and distribution.

The occurrence of IPN- outbreaks in Norway through the 90s has been well documented. On basis of several national surveys (Eithun 1994, Bruheim 1995, 1997, Brun 1998, 2001) the outbreak frequency on site level is shown to vary from 40 – 70 % (Figure 1). In all

these reports, site was defined positive if it contained one or more groups showing increased crude mortality associated with characteristic clinical symptoms of IPN and a histopathological and immunohistochemical examination verifying the presence of characteristic lesions and IPNV-antigens in organs of sampled fish. Number of outbreaks was registered during an observation period defined from sea transfer to a fixed date in autumn the same year assuming this period to be the time of expected IPN-outbreaks. This means that not all the groups were given equal risk-time to develop an IPN-outbreak during the given observation period. Both Jarp (1991) and Brun (2001) have shown that the median time from sea transfer to IPN outbreak in post smolts observed for such a period, is about 35 days (range 3 – 75, Brun 2001). The “incubation period” was calculated in days and not “day-degrees” which would have given a more correct estimate of time to outbreak.

...probably as a result of the open national market for smolt purchase and distribution...

None of these reports investigated the within-group or within-site prevalence of IPNV.

Figure 1. Proportion of sea sites with IPN-outbreaks in post smolts transferred to sea in spring (2000 include both spring and autumn transfers)

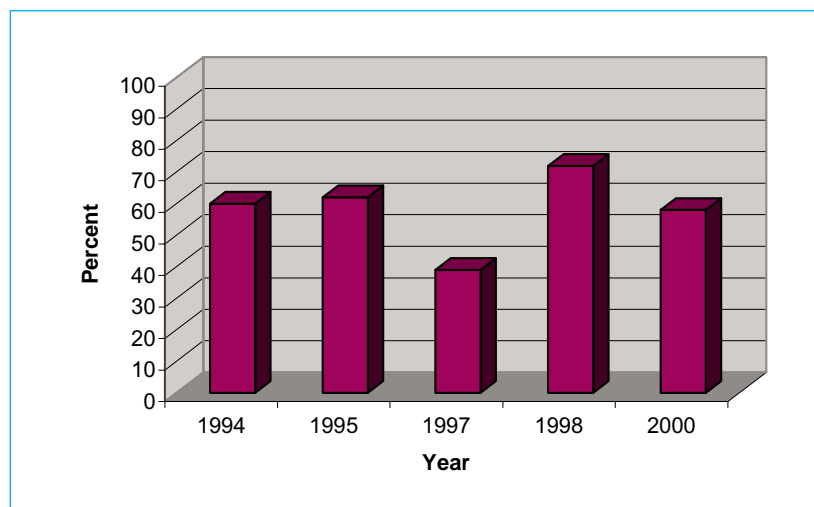

In comparison to the national surveys, regional surveys in Mid-Norway registered IPN-outbreaks on 69 % of observed sea sites in 2001 varying between 78 % and 89 % for the years 1998 – 2000 (Bruheim 2001) (*see also 1.2.4.*).

#### 4.1.3. Occurrence of IPN-virus and outbreaks in hatcheries

IPN outbreaks were reported in 32 %, 41 % and 39 % of all hatcheries observed in national surveys by Eithun (1994), Bruheim (1997) and Brun (1998), respectively. Seventy-nine percent of the outbreaks appeared between March and July with most frequent outbreaks in June and July. Fifty-one percent of the outbreaks affected parr less than 20 gram, although a few groups with an average weight of 180 gram were also affected (Brun 1998).

When observing the production cycle from egg to smolt, prevalence of virus at group level increased from zero at the egg stage, to 20 % at smolt stage. The within group prevalence at yolk sac-/fry- stage was seven percent increasing to 62.5 percent at smolt stage (Jarp 1998).



#### 4.1.4. Geographical distribution

The different national and regional surveys have pointed out regional differences regarding IPN-problems. Jarp (1994), Bruheim (2000) and Brun (2001) have all shown how IPN outbreaks and accumulated crude mortality vary between regions. Sogn & Fjordane seems to be a county with moderate problems while Møre & Romsdal and Trøndelag are more heavily affected. Finnmark County has not been included in any of the national surveys. There are few reports of IPN outbreaks in this part of the country. None of the authors proposes any theories explaining the regional differences.

Murray (2003) describes similar regional variation from Scotland and shows how the regional pattern actually dominates the structure of variation in IPNV prevalence in salmon farms. However, they also emphasize that these differences have become less distinct through the years 1996–2001 as the prevalence of virus increased and positive regions converged.

...regional differences indicate a possibility to reduce the impact and prevalence of IPNV...

Both Jarp (1994) and Murray (2003) conclude that regional differences indicate a possibility to reduce the impact and prevalence of IPNV.

#### 4.1.5. IPNV- caused mortality

Smail et al (1992) concluded that the IPNV Sp-serotype was strongly associated with clinical disease in Atlantic salmon post smolts and that environmental and management factors probably contributed to the mortality as well as acted together with the PD (pancreas disease)–virus. IPN-associated mortality in post-smolts was also described by Jarp (1994) who showed that there were regional differences in IPNV caused mortality in spite of high incidence of IPN outbreaks in all regions. These studies were the first to demonstrate the association between mortality and IPN in post smolts.

Accumulated crude mortality related to IPN–outbreaks in post-smolts varies on average from 10 % to almost 20 %. The range may go from just a few percentages to more than 90 % (Bruheim 2001, Brun 2000). Crude mortality is often used as a response variable, but no studies have focused on the IPN-specific part of this figure.

#### 4.1.6. Impact of vaccination

IPN vaccination was introduced in 1995 and soon came into extensive use. The IPN-vaccine coverage on a national basis for smolts transferred to sea in spring 1997 was 68 %, and 56.8 % in 2000 (Brun 1998, Brun 2001). In a recent regional study covering Trøndelag and the northern parts of Møre, 96.3 % of the groups were IPN-vaccinated (Bruheim 2001). The national IPN-vaccine coverage was estimated to 65 % in 2000, 79 % in 2001 and 85 % in 2002 (Vik Mariussen 2003).

How the vaccine coverage has affected the prevalence and geographical occurrence of IPN has not been unambiguously determined. None of the annual national or regional surveys have managed to document any protective vaccine effect regarding number of outbreaks, mortality or time from sea transfer to outbreak (Brun 2001, Bruheim 2000). Bruheim (2001) however, indicates a “certain” non-significant vaccine induced protection when summarising his results over three years, estimating a prevalence of 68 % in IPN-vaccinated groups (accumulated crude mortality 14.0 %) and a prevalence of 60 % (accumulated crude mortality 16.3 %) in non-vaccinated groups. The calculation included a total of 436 groups where 35 (eight percent) were not IPN-vaccinated (Table 2).

Table 2. Annual IPN-vaccine coverage and IPN outbreaks in vaccinated groups based on Bruheim 2001

	1998	1999	2000	2001
Proportion of IPN-vaccinated groups among IPN positive groups (proportion cases vaccinated)	0,88	0,95	0,95	0,96
Proportion IPN-vaccinated groups in the study population (vaccine coverage)	0,88	0,94	0,90	0,96

From Table 2 it is obvious that there is no effect of the vaccine on outbreak frequency. If there is any trend from crude mortality data, this should anyway be interpreted with considerable caution. Lack of vaccine protection is in accordance with surveys of smolts transferred to sea during 2000 where actually non-IPN-vaccinated fish tended to show a lower frequency of IPN than vaccinated fish (Brun 2001, Bruheim 2000). The great extent to which IPN- vaccination never the less, is used in Norwegian salmon production underlines a demand to do well designed field studies specifically aimed to evaluate the effectiveness and efficacy of the IPN-vaccine. Such studies should also aim to elucidate the discrepancy in observed effect between field surveys and controlled clinical trials done by the vaccine industry (6.4.).

## 4.2. Analytical epidemiology

### 4.2.1. Risk of introducing virus to hatcheries

*IPNV may be introduced into the hatchery by eggs, fry, human, fomites, different animals, and water. No studies have fully evaluated the different impacts of these possible introductory alternatives.*

It is generally accepted that IPNV may be transmitted vertically and can be introduced to a hatchery by imported fertile eggs and/or fry (3.1 and 1.1.1.). The virus appear to exist inside the eggs as disinfections of eggs is not related to introduction of IPNV to hatchery (Jarp 1998) and surface disinfections of eggs is not entirely effective in preventing vertical transmission (Bullock, 1976). Hatcheries buying fry are shown to increase their risk of IPN-outbreaks, which may be related to increased risk of virus introduction (Jarp 1998, Brun 1998, Bruheim 1998, 2000) (5.1.2.4.).

IPNV is extremely contagious in hatchery facilities, and fomites and humans are apparently capable of transmitting the virus horizontally within and between fish rearing facilities (Reno 1999). The virus is also capable of surviving in the intestinal system of mammals and birds for several days (Reno 1999) making e.g. mink (*Mustela* sp.) (Sonstegård 1972) and gulls (*Larus ridibundus*) (Jørgensen 1974) potential vectors (3.3.6./3.3.7.).

When observing the whole production cycle from egg to smolt, prevalence of virus at group level increased from zero at the egg stage, to 20 % at smolt stage (Jarp, 1998). The within group prevalence at yolk sac-/fry- stage was seven percent increasing to 62.5 percent in smolt groups. In another trial 25 % of the groups were IPNV-positive with a within group prevalence of 59 %. Sixty-seven percent of the 2-year-old smolts were IPNV-positive while 21 % of the 1-years were positive. These results show how there seems to be a building up of virus in fish during time spent in the hatchery. This may be a result of a continuous influx of virus or a gradually spreading of virus both within the hatchery and within groups.

McAllister and Bebak (1997) detected IPN-virus in effluent discharge 19 km below an infected hatchery (3.3.3.). The prevalence of IPNV infection in stream resident fish was two point five percent. Similarly, Oretga (1995) isolated IPNV from nase (*Chondrostoma toxostoma*) and gudgeon (*Gobio gobio*) residing upstream and downstream from rainbow trout farms in which IPNV was detected. No closer identification of strains was performed. Whether carrier fish in the water source impose a parallel risk of IPNV-introduction to a hatchery, is not known. However, preventive measures cited by the OIE, include the use of protective water supply (e.g. spring and borehole ponds) where ingress of fish, particular possible virus carriers, is prevented. Jarp et al (1998) did not demonstrate any connection between water source (migration of anadromous fish into the fresh water supply) and IPN outbreaks. This was in contrast to findings regarding the risk of infection with *Aeromonas salmonicida* subsp. *salmonicida* in hatcheries (Jarp 1993). The outcome in the latter study was outbreak of furunculosis. Lack of demonstrable association with outbreaks of IPN may not exclude risk of virus introduction, as there may be a stronger association between the introduction of *A. salmonicida* and furunculosis compared to the introduction of IPNV and an IPN outbreak.

...isolated IPNV from fish residing upstream and downstream from rainbow trout farms...

Jarp (1998) showed that virus titre in fry increased when they were exposed to a mixture of freshwater and seawater. It is not known if seawater actually imposes an increased exposure of virus or if a physiological stress effect causes an increased production/release of virus (3.3.3.).

#### 4.2.2. Risk of IPN-outbreaks in hatcheries

*IPNV seems to be very persistent once introduced into a hatchery unless active eradication measures are taken. Buying fry is repeatedly shown to increase the risk of outbreaks, and IPN outbreaks in previous years also increase the risk of new ones. Lining of hatching tanks by Astroturf has in one study been associated with IPN outbreaks in fry. This may be explained by hygienic problems. It is proposed that superoxygenation itself and the specific water chemistry in the mixing zone between different water qualities (e.g. saltwater and freshwater) may in general make both fry and smolts more vulnerable to infectious agents such as IPNV.*

Once present in a facility, the infection will remain for long periods in the absence of active measures to eradicate the agent. Reno (1999) illustrates this by examples of hatcheries being infected for decades and the knowledge of only a few cases where IPNV naturally has been eliminated from a population of carrier fish. Jarp (1998) supports this observation of persistence of infections in hatcheries by concluding that IPN outbreaks in previous years increased the risk of new outbreaks, a finding also done by Brun (1999).

...buying fry is repeatedly shown to increase the risk of outbreaks...

Dodson and Torch (1981) observed a linear decrease in mortality of rainbow trout fry due to IPN-infection with increasing age (measured as degree-days). Resistance to clinical disease was reached at about 1500 dg (degree-days) (2.6.1.). At low temperatures IPN could be delayed and represent a long lasting disease. Elevating the temperature protected fry from IPN and shorten the period during which they were susceptible to the disease. The mechanisms behind the evolved resistance at about 1500 dg is not known, but might be of interest in comparison to the apparent lack of such resistant factors in Atlantic salmon.

Experience indicates that increasing production intensity by which smolts are produced, has caused increased problems both for fry and smolts in the hatcheries and for the post-smolts later in sea farms. IPN is one of the diseases associated with this “intensity”-component. Based on results from a water quality programme administered by NIVA (Norwegian Institute for Water Research), it is revealed that several hatcheries are capable of only bringing 20 % of the water needed for a natural supply of sufficient oxygen to the fish. About 70 % of the hatcheries participating in the programme have a specific water consumption of less than 0.3 l/kg/min (Rosseland 2002). Superoxygenation (200 – 300 %) is one solution meeting this shortage of water. It is hypothesised that the imposed oxidative stress is associated with specific negative side effects weakening the fish in the fresh water phase as well as causing long-acting effects revealed by reduced performance and increased susceptibility to diseases such as IPNV, post sea-transfer.

...elevating the temperature protected rainbow trout fry from IPN...

Another way of meeting water shortage is the use of seawater. Jarp (1998) showed in a cohort study that fry exposed to a mixture of seawater and fresh water increased the risk of IPN outbreaks. This conclusion was supported although not statistically significantly, in a case-control study (Odds ratio (OR)=2.2 (95%-confidence interval (95%CI): 0.6 – 6.0)). Brun (1998) found no association between seawater intake and IPN-outbreak in hatcheries while Bruheim (2000) on the other hand, did find such association.



Water quality as risk factor for diseases, mortality and reduced performance both in fresh water and in seawater, is scarcely evaluated and should be more focused. Although difficult as it may be, plausible specific water quality variables should be included in risk factor studies. Measuring essential water chemicals will strengthen any observed statistical association between a disease and a lump factor describing water quality (e.g. stocking density) if there is a causal relationship.

The use of Astroturf lining in hatching cylinders are associated with increased risk of IPN-outbreaks (Jarp 1998). The given OR=6.3 was highly significant ( $p=0.006$ ) and indicate a strong association to the response variable and a less likelihood of being confounded. The plausible explanation for this effect may be related to hygienic conditions.

Lack of movement restrictions on staff, migration of anapropous fish into fresh water supply and a high concentration of infected fish farms (seawater) near the hatchery, are shown to be risk factors for outbreak of furunculosis in hatcheries (Jarp et al 1993). Similar findings are not demonstrated for IPN-outbreaks (Jarp 1998).

#### 4.2.3. Risk of introducing virus to sea sites

*All experience support the theory that IPNV is primarily introduced to a sea site by purchased smolt. However, genome research has revealed that “the truth” might be more complicated and molecular techniques are promising and necessary tools for further epidemiological research. These techniques may also reveal the possible importance of horizontal transmission by visiting smolt-transporting vessels and local reservoirs as part of the introductory history.*

Purchase of smolts from more than two hatcheries increased the risk of an IPN outbreak by OR = 2.9 (95%CI: 1.1- 7.7) compared to deliveries restricted to one and two hatcheries (Jarp et al 1994). In the same study smolts transferred to sites never used before, showed a higher risk of IPN outbreak than if the fish was transferred to sites used for 2 –18 years (OR=3.4, 95%CI: 1.2-9.0). The outcome of this study was IPN-outbreaks (3.1.2.4.). Although there was no isolation or characterization of virus in the different groups, the study supported the theory of IPNV being introduced by smolts delivered to the site, and was not a result transmission from a marine reservoir (Jarp et al 1994, Rønning & Jarp 1996).

Melby (1991) concluded that all commercial Atlantic salmon seawater farms in Norway harbour carriers of IPNV and also, most isolates both from outbreaks and non-diseased fish (88 % and 80 %, respectively) was of the Sp-serotype, N1 strain. Just a few of the isolates reacted similar to Abs, He and Te (Kroger et al 1989, Melby et al 1994, Melby and Christie 1994). Serotype Sp is regarded most pathogen and has been associated with mortality rates

...a marked serotype homogeneity in farmed salmon in contrast to the variety in wild salmon...

of up to 90 %, while serotype Abs has never exceeded 10 % (Jørgensen 1974) (2.3.1.). As the outcome of the study was “IPN-outbreak” and cases and controls could be regarded equally infected by the same serotype, the above study indicates that virus introduction as such is

not a sufficient determinant for disease. There has to be other factors that determine whether or not disease will occur.

In general terms, a large number of hatcheries may per se increase the risk of introducing (pathogenic) IPNV to the site. More specifically supporting the theory of a hatchery effect on the introduction of virus is the finding that farmed post-smolts was equally infected both in the north and in the south of Norway (Melby 1991). Also, the marked serotype homogeneity in farmed salmon in contrast to the variety among isolates in wild salmon is supportive (Taksdal 2003) as well as an “incubation-time” of as little as three days for some outbreaks indicates that the virus most likely has been brought to the sea site by the smolts. These findings altogether, indicate that the delivering hatcheries play an important role in introducing IPNV to sea sites.

The effect seen by several delivering hatcheries could also have been associated by a possible increased number of deliveries (Murray, 2002). Number of deliveries was not questioned in the above study.

Dannevig (2003) used genome sequencing to show that IPNV isolates from an outbreak in a hatchery was not identical at the nucleotide level to virus isolates in post-smolts of the same hatchery-group, suffering IPN outbreak in seawater. This might show that the direct link between hatchery and seawater site is not clear-cut (5.1.2.3.).

Genome sequencing is a promising tool for further progress in epidemiological studies regarding tracking the source of infection (virus introduction) as well as improving the quality of causal studies. The use of genetic characterization of virus isolates has already been used to investigate spread of infectious hematopoietic necrosis virus (IHN) between seawater farms in Canada (St-Hilaire 2002).

The increased risk of “age of site” is difficult to explain and is probably due to confounding from non-identified factors as the authors suggest (Jarp 1994). Wheatley (1995) studied association between site management and site mortality as an indicator of overall health status. They concluded that fallowing, single generation rearing and



movement restrictions on staff significantly reduced crude mortality rate. No association was found to age of site, site depth or net clearance of the seabed. These conflicting results and lack of associations illustrate some of the complexity of site as unit and in general the difficulties in using a “lump” variable.

#### 4.2.4. Risk of IPN-outbreaks in sea sites

*Defined risk factors such as mixing populations from many hatcheries and transportation method may be related to stress inducing a recrudescence in carriers. So far there are no convincing studies supporting any theory of IPN outbreaks in freshwater being protective against outbreaks in seawater, nor making the post –smolts more susceptible. Size of smolt at transfer may be of importance and should always be included in risk factor studies. It is proposed that smolts coming from a hatchery with high degree of superoxygenation may in general show increased susceptibility to infectious agents as IPNV.*



In a retrospective longitudinal cohort study Jarp (1994) ended up with a final model including number of hatcheries delivering smolts, age of site and county as risk factors for IPN outbreaks in post-smolts. This is the same study mentioned above dealing with introduction of virus to sea sites, but the design is more relevant for outbreaks as outbreak is the dependent variable.

Purchase of smolts from more than two (three and four) hatcheries increased the risk of an IPN outbreak by OR =2.9 (95%CI= 1.1 – 7.7) compared to deliveries restricted

...it is proposed that superoxygenation may increase susceptibility to IPNV...

to one and two hatcheries (Jarp et al 1994). The confidence interval allows for an effect of substantial importance. In general, calculating relative risk (RR) would probably have been more appropriate in a cohort study of a common disease. This would have given a lower value as OR tends to be further away from one than the RR. Anyway, the conclusion is plausible, as many different deliveries may have caused increased susceptibility (recrudescence) due to a social stress reaction or increased risk of introducing a specific pathogenic genotype. Mixing livestock of different origin is in general well known to increase the risk of disease outbreaks.

Several potential risk factors may be associated with acute or chronic stress. In extreme, Taksdal (1998) exposed post-smolts experimentally to excessive stress by water drainage in order to provoke IPN outbreaks in infected fish. Similarly, Sommer (2001) showed in a controlled trial how IPN-problems were associated by the intensive rearing conditions in hatcheries. Helicopter transport from hatchery to sea site increased the risk of IPN outbreaks in post-smolts (Jarp 1994).

Murray (2002) presented evidence for an association between number of visits by vessel carrying fish and contamination of farms with ISA-virus. Bruheim (2000) reported over a three-year period (1998-2000) that only three out of 54 hatcheries (5.6 %) produced smolts that did not experience IPN outbreaks after sea transfer

In another longitudinal study Jarp (1996) concluded that groups in which clinical outbreaks of IPN had occurred in the early freshwater period (as fry), where at higher risk of IPN outbreaks in seawater if specific antibodies could be demonstrated at the time of seawater transfer. On the other hand, protection against IPN outbreaks was seen in groups with specific antibodies present at sea transfer and no record of IPN outbreaks in the freshwater

phase. These two findings are based on RR- estimates with very broad confidence intervals, both including 1. Small sample size explains the wide confidence intervals on estimates, which also implies low power in the analyses. The defined risk factors are questionable on the basis of this study. The use of specific antibodies as a response variable may in general be questioned due to great variability and lack of response in individual fish (Taksdal 1998) (5.1.2.2).

Smail (1992) proposed that fry surviving an IPN outbreak is at higher risk of another outbreak by recrudescence of the infection post sea transfer. Sommer (2001) exposed salmon in the fresh water phase for intensive rearing conditions (superoxygenation, low water supply and high density) two months prior to sea transfer. If this fish was given an IPNV challenge prior to this (became carriers at fry stage), the intensive rearing conditions didn't increase IPN-problems post sea transfer as was actually seen if the IPNV challenge appeared after this intensive period. Bruland (2000) has repeatedly found that outbreaks in freshwater phase (including early stages) reduce the risk of recurrent IPN in seawater (Table 3). RRs calculated on data from Bruheim (2000) support this trend, but the report does not give sufficient information for calculating confidence intervals or perform multivariate analyses.

Table 3. Association between IPN outbreaks in hatchery and in post smolts in seawater based on Bruheim 2002 (CI for relative risks (RR) are not estimated due to lack of information)

	Proportion of groups with IPN in seawater (%)		
	1998	1999	2000
Proportion of groups with clinical IPN in hatchery	64	46	44
Proportion of groups without clinical IPN in hatchery	80	65	65
RR	0,8	0,70	0,68

Bruheim has found that smolts transferred to sea at a weight of more than 110 gram have reduced risk of IPN outbreaks in seawater. Jarp (1998) showed that transfer of two- year-old smolts reduced the frequency of IPN-outbreaks in seawater, and the risk of IPN in late sea transfers increased by low weight of the smolts.

No association was found between IPN outbreaks and the capacity for osmotic regulation at time of sea transfer.

Jarp (1994) demonstrated lower mortality in 2- versus 1-year-old smolts. These findings indicate that size may influence the sensitivity for developing disease, and is important to include in a risk factor study. Thorburn (2001) emphasizes specifically the importance to control for size, age, and growth rate (or its components, temperature and feeding rate) in field studies of diseases incidence in fish. Jarp (1998) found that sites with IPN outbreaks tended to have a lower feeding rate than non IPN-sites and "feed producer" was associated with risk of outbreak. These findings have not been further investigated.

The mixing zone between different water qualities is shown to be of specific interest regarding the toxicity of aluminium (Al) (Rosseland 2002). Increased polymerisation of Al-compounds may weaken the smolts in fresh water and make the post-smolts more vulnerable to infectious agents as IPNV. So far this is just a hypothesis, but focuses the importance of the water environment in hatcheries to produce healthy post-smolts.

IPN–outbreaks post sea transfer were more frequent when time in hatching cylinders exceeded 30 days (Jarp 1998). Day-degrees were not given and there is no obvious theory behind this finding.

Inter-annual variation in occurrence of outbreaks is registered both in Norwegian and Scottish surveys (Bruheim 2001, Murray, 2003), but no clear-cut seasonal patterns are registered.

#### 4.2.5. IPNV and other virus infections

*The possibility that IPNV could be a risk factor for other emerging infections should be investigated.*

Few studies have investigated any association between IPNV infection and other infections. Jarp (1996) investigated the impact of EIBS (erythrocytic inclusion body syndrome), and did not find any relationship to the risk of clinical IPN in post-smolts. However, the authors conclude that the EIBS load may have been too low to impose any risk. Brun (2003) found a significant association between previous IPN outbreaks in seawater and occurrence of cardiomyopathy syndrome (CMS) in Atlantic salmon. Through the last few years several new assumed infections have appeared. The theory that IPNV or IPN-outbreaks may be associated with this increasing number of (viral) infections emerging in farmed Atlantic salmon is interesting to focus and investigate further.

...significant association between previous IPN and CMS...

#### 4.2.6. Modelling

*Modelling and simulating IPN outbreaks are important for a closer understanding of the horizontal spreading of the infection both between and within a population. There are few studies on this topic although model building in general may improve the insight into population dynamics of infectious agents and understand underlying factors of transmission. The referred studies show how density and infection load is associated.*

IPN may be defined as a highly contagious viral disease in fish kept under intensive rearing conditions. As such, high density is one of the main risk factors associated with outbreaks of any infectious disease. A reduction in the population density ('thinning out') may help to reduce the overall mortality during an outbreak, and the principle is firmly established and used as preventive and control measure.

Smith (2000) suggested that an IPN epidemic in a defined system is a point source epidemic instead of a propagative epidemic. Knowledge of the dynamic of an epidemic is important for future modelling which so far is poorly developed in fish disease epidemiology. Bebak-Williams (2002) support this theory by experimentally showing for rainbow trout fry that fish density, number of infectious fish (as a representation of pathogen concentration) and the interaction between the two variables significantly affect time to death from IPN. The effect of "thinning out" on peak death rate was most obvious when there were relatively few infectious fish present. If there was a high number of infectious fish, the effect of density diminished.

#### 4.2.7. Effects of genetics

*There are few published studies on genetic resistance to the impact of IPNV. In Japan, a genetic line has been produced in rainbow trout showing resistance to a specific IPN-strain. This resistance was genetically transmittable and relatively stable. In Norway challenge tests revealed a great variety in IPNV-resistance between different families and siblings illustrating the potential of a breeding programme. Field observations are not convincing regarding brood stock as risk factor.*

IPNV-challenge tests have been performed on different families and groups of half-siblings of Atlantic salmon fry (0,15-0,20 g) in controlled trials at VESO Vikan (Storset 2003). These tests have shown differences between both families and sibling groups with respect to IPN-outbreaks and mortality indicating that 15-30 % of the variation in mortality is due to inheritance. Parallel groups have been tested in a field outbreak where the correlation between mortality in the experimental testing and the field challenge was 0.56; validating both the experimental test system and the results. Mortality in this field trial was 21%, which is equal to average IPN-related crud mortality on a commercial site. Resistance to IPNV was clearly demonstrated in a strain of rainbow trout evolved in a commercial hatchery (Okamoto 1993). Survivors among affected fish were subjected to mortality checks through successive generations and the resistance manifested in the strain were genetically transmittable and relatively stable.

AquaGen is the dominant breed in Norwegian salmon production supplying almost 100% of the stockfish to North-Norway, 62% to Mid-Norway and 39% to Southwest-Norway. Bruheim (2000) included brood stock as a risk factor in his field surveys and concluded that brood stock might increase the susceptibility to IPN-outbreaks (Table 4). The conclusion is based on the crude data (not controlled for any confounding or biased effects related to the dominance of AquaGen) and should be carefully interpreted.

Table 4. Occurrence and crude mortality due to IPN-outbreaks related to brood stock (Bruheim 2000)

Brood stock	Number of groups			Occurrence of IPN outbreaks (%)			Mortality (%)		
	1998	1999	2000	1998	1999	2000	1998	1999	2000
1	171	237	191	80	59	65	17,3	17,1	9,5
2	15	12	13	73	8	56	5,5	2,2	20,3
3	14	8	12	43	75	8	15,9	11,7	20,9
4	22	21	11	55	52	9	17,3	6,3	1,0
5	13	7	2	54	29	0	15,6	3,1	3,1

#### 4.2.8. Future epidemiology

Descriptive studies or surveys are studies dealing with quantification and pattern of a health phenomenon in a population. A lot of the descriptive information on IPN in Norway is gathered by regional and national conducted surveys, and give a reasonable picture of the occurrence in space and time of IPN outbreaks in Norwegian salmon production. Likewise, the prevalence of IPNV seems well documented through several studies. However, the most common serotype is shown to exist in different variants showing different virulence. Today's documentation of IPNV-prevalence is based on viral characteristics that do not separate these variants. The genome of IPNV has been well characterised and it is now important to use this knowledge together with molecular techniques to improve our understanding of the genetic variety and impact of IPNV in Norwegian fish farms.

Risk factor studies aim to detect risk factors. These should be proven “righteous” in repeated well-designed studies and in different settings using correct statistical procedures. The different studies referred to, have investigated and defined a number of factors associated with IPN-outbreaks. Some of the factors are investigated repeatedly and some

...the need for rapid and practical results in aquaculture has the effect that epidemiological results quickly have become truths....

not more than once. The studies have been designed and analysed differently, some inadequately for the concluding results. The need for quick and practical results in aquaculture has had the effect that epidemiological results quickly have become truths, sometimes without the necessary validation, and the assumptions and limitations forgotten. Discrepancies between “truths” may then easily evolve.

Proper identification of units of concern (e.g. sites, pens, and individual fish) is essential in epidemiological studies, as well as the possibility to collect reliable and exact information on response variables and potential risk factors. In salmon production this is often difficult and some of the problems in fish epidemiology may be imbedded in the dynamic nature of salmon production routines. Frequent grading, mixing, moving of populations both in the freshwater and seawater stages and the quality of recording systems, make it difficult to fully characterize the different groups. Improved tracing and compatibility between computerized recording systems can make the huge amount of data routinely gathered every day by the industry, available for research and thus, make it possible to reveal the information inherent in these data by use of epidemiological methods.

The aspects of reliability constitute the basics of two major problems in risk factor studies; bias and confounding. Confounding may be statistical dealt with if sufficient information is available, but bias is a part of the design and will unmistakably influence the result. If as an example, the definition of outcomes does not clearly manage to group cases and non-cases in unique, separate groups this will lead to non-differential bias and lessen the strength of any statistical associations. Broad and practical definitions on IPN-outbreaks and mortality may have deflated the effects in the preformed studies. Several of the calculated odd ratios and relative risks are close to 1 or have a confidence interval that almost includes 1. Their importance in the causal mechanisms should therefore be further investigated.

Jarp (1994) points out that the significant association between weight and morbidity in a bivariate screening disappeared when controlling for age, transport method and site. This example illustrates the need to include the contributions of different risk factors to a single event into the analysis and make proper adjustment for confounding factors and/or effect modifiers (interactions) in order to separate the independent contribution of each factor. Results not based on prudent statistical (and epidemiological) principals may create erroneous conclusions in either direction. The use of multilevel analysis makes it possible to deal with units at different levels (e.g. pens, site, and region) and will further improve the statistical results in aquatic epidemiology.



The use of molecular techniques makes it possible to define IPNV-cases in a much more specific manner than before, and thereby improve the possibilities to reveal associations between risk factors and disease. It is essential for further progress to apply these techniques in future risk factor studies.



Thorburn (1987) published the very first analytical epidemiological study on risk factors for vibriosis. Later, Jarp (1993) and Vågsholm (1994) conducted risk factor studies on furunculosis and infectious salmon anaemia giving results applicable for intervening measures. St-Hilaire (2002) did a descriptive retrospective study on outbreaks of IHN in seawater farms occurring 1992-1996 and an evaluation of the proceeding surveillance programme. These, as most studies through the 90s, have studied “farm” risk factors, which have been important for initiating control and preventive measures. For future risk factor studies, there should be a greater focus on longitudinal cohort studies in order to reveal causal associations and evaluate the impact and economic significance of different factors. To achieve this, it is essential to establish clear hypothesis involving plausible risk components, as refined as possible. To reach further into clarifying the causation of infectious diseases in aquaculture, it is also necessary to conduct valid within-farm studies (Georgiadis 2002).

### 4.3. References

1. Ariel, E. and N.J. Olesen. 2002. Finfish in aquaculture and their diseases – A retrospective view on the European Community. Bull Eur. Ass. Fish Pathol. 22 (2): 72-85.
2. Aunsmo 2203a. Pers.comm.
3. Aunsmo 2203b. Annual report from "Helsetjenesten for Kultiveringsanlegg" 2002, VESO Trondheim
4. Bebak-Williams, J.,P.E.McAllister,and R.Boston.2002. Effect of fish density and number of infectious fish on the survival of rainbow trout fry, *Oncorhynchus mykiss* (Walbaum), during epidemics of infectious pancreatic necrosis. J. Fish Dis. 25: 715-726.
5. Bruheim, T. 1991. Smoltdødelighet – erfaringer fra Trødelagskysten Nor Fiskeoppdr 3: 44-45.
6. Bruheim, T. 1995. Utbredelse og betydning av sykdommen IPN hos laks i settefisk og matfiskanlegg i Norge. Rapport. Veterinærinstituttet.
7. Bruheim, T. 1997. Utbredelse og betydning av sykdommen IPN hos laks i settefisk og matfiskanlegg i Norge. Rapport. Veterinærinstituttet.
8. Bruheim, T. 1998. Utbredelse og betydning av sykdommen IPN hos laks i matfiskanlegg i Midt-Norge og på Nord-Vestlandet i 2000. Rapport. Veterinærinstituttet.
9. Bruheim, T. 2000. Utbredelse og betydning av infeksjøs pancreasnekrose (IPN) hos laks i matfiskanlegg i Midt-Norge og på Nord-Vestlandet i 2000. Rapport. Veterinærinstituttet.
10. Bruheim, T. 2001. Utbredelse og betydning av infeksjøs pancreasnekrose (IPN) hos laks i matfiskanlegg i Trøndelag og Nord-Møre i 2001. Rapport. Veterinærinstituttet
11. Brun, E. 1998. Utbredelse og betydning av sykdommen IPN hos laks i norske settefisk- og matfiskanlegg. Rapport .Veterinærinstituttet.
12. Brun, E. 2001. A Field Study to Evaluate Vaccination against Infectious Pancreatic Necrosis in Sea Farmed Atlantic Salmon (*Salmo salar* L.) in Norway. MSc –thesis. Veterinærinstituttet
13. Brun, E., T. Poppe, A. Skrudland, and J. Jarp 2003. Cardiomyopathy syndrome in farmed Atlantic salmon (*Salmo salar* L.) occurrence and direct financial losses in Norwegian aquaculture. Submitted to Dis. Aquat. Org.
14. Bullock, G.L., R.R. Rucker, D. Amend, K. Wold, and H.M. Stuckey. 1976. Infectious pancreatic necrosis: transmission with iodine-treated and non-treated eggs of brook trout (*Salvelinus fontinalis*). J. Fish Res. Board Can. 33: 1197- 1198.
15. Crockford, T., M.F. McLoughlin, F.D.Menzies, E.A. Goodall, and S.B.Wheatley. 1998. Epidemiological investigations of diseases in farmed Atlantic salmon (*Salmo salar*) in Ireland. Proceeding from Society for Veterinary Epidemiology and Preventive Medicine, 25<sup>th</sup> –27<sup>th</sup> March, Ennis.
16. Dannevig, B., C. Thomassen, C. M. Jonassen, N. Santi, I. Modahl, M.J. Hjortaas, T. Taksdal, Ø. Evensen. 2003. Genetic characterization of IPN-virus in a hatchery without IPN and in a sea farm with IPN and with fish originating from the hatchery - preliminary results. Lecture given by C. M.Jonassen at the National Veterinary Institute.
17. Dorson, M. and C. Torchy. 1981. The influence of fish age and water temperature on mortalities of rainbow trout, *Salmo gairdneri* Richardson, caused by a European strain of infectious pancreatic necrosis virus. J.Fish Dis. 4: 213-221.
18. Eithun, I. 1994. Utbredelse og betydning av sykdommen IPN hos laks i settefisk og matfiskanlegg i Norge. Rapport. Veterinærinstituttet.

19. Georgiadis, M. P., I. A. Gardner, and R. P. Hedrick. 2001. The role of epidemiology in the prevention, diagnosis, and control of infectious diseases in fish. *Prev. Vet. Med.* 48: 287-302.
20. Haydon, D.T., S. Cleaveland, L.H. Taylor, and M. K. Laurenson. 2002. Identifying Reservoirs of Infection: A Conceptual and Practical Challenge. *Emerg. Infect. Dis.* 8 (12): 1468 – 1473.
21. Jarpe, J., K. Tangen, F.V. Willumsen, H.O. Djupvik, and A.M. Tveit. 1993. Risk factors for infection with *Aeromonias salmonicida* subsp. *salmonicida* in Norwegian freshwater hatcheries. *Dis Aquat Org.* 17: 81-86.
22. Jarpe, J., A.G. Greve, A. B. Olsen, and T. Bruheim. 1994. Risk factors for furunculosis, infectious pancreatic necrosis and mortality in post-smolt of Atlantic salmon, *Salmo salar* L. *J. Fish Dis.* 18: 67-78.
23. Jarpe, J., T. Taksdal, and B. Tørud. 1996. Infectious pancreatic necrosis in Atlantic salmon *Salmo salar* in relation to specific antibodies, smoltification, and infection with erythrocytic inclusion body syndrome (EIBS). *Dis. Aquat. Org.* 27: 81-88.
24. Jarpe, J. 1998. Div foredrag og framdriftsrapport av 1.8.98 for NFR-prosjekt 110561/122 Epidemiologiske studier av IPN hos laks.
25. Jarpe, J. 1998b. Experience with the use of Aquatic epidemiology in Norway. Epidemiological investigations of diseases in farmed Atlantic salmon (*Salmo salar*) in Ireland. Proceeding from Society for Veterinary Epidemiology and Preventive Medicine, 25<sup>th</sup> –27<sup>th</sup> March, Ennis.
26. Jarpe, J and H. Melby. 1997. A prospective study of infectious pancreatic necrosis in farmed Atlantic salmon post-smolt. *Epidémiol.santé.anim.* 31-32.
27. Jarpe, J. 1999. Epidemiological aspects of viral diseases in the Norwegian farmed Atlantic salmon (*Salmo salar* L.). *Bull. Euro. Ass. Fish Pathol.* 19 (6): 240 – 244.
28. Jørgensen, P.E.V. 1974. A study of viral diseases in Danish rainbow trout, their diagnosis and control. PhD –Thesis at the State Veterinary Serum Laboratory, Department for Jutland, Århus.
29. Krogsrud, J., T. Håstein, and K. Rønningen. 1989. Infectious pancreatic necrosis in Norwegian fish farms. In *Viruses of Lower Vertebrates*. Eds: W. Ahne and E. Kurstak. Pp.: 284-291. Springer-Verlag, Berlin.
30. Last, J. M. 2001. *A Dictionary of Epidemiology*. 4 edition, Oxford University Press
31. McAllister, P.E. and J. Bebak. 1997. Infectious pancreatic necrosis virus in the environment: relationship to effluent from aquaculture facilities. *J. Fish Dis.* 20: 201-207.
32. Melby, H.P., J. Krogsrud, T. Håstein, and H. Stenwig. 1991. All commercial Atlantic salmon seawater farms in Norway harbour carriers of infectious pancreatic necrosis virus (IPNV). In: *Proceedings from 2<sup>nd</sup> International Symposium on viruses of Lower Vertebrates*. Ed J.L. Fryer, pp 211-217. Oregon State University, Corvallis, OR, USA.
33. Melby, H.P. , P. Caswell-Reno, and K. Falk. 1994. Antigenic analysis of Norwegian aquatic birnavirus isolates using monoclonal antibodies with special reference to fish species, age and health status. *J. Fish dis.* 17: 85-91.
34. Melby, H.P. and K.E. Christie. 1994. Antigenic analysis of reference strains and Norwegian field strains of aquatic birnaviruses by the use of six monoclonal antibodies produced against the infectious pancreatic necrosis virus N1 strain. *J. Fish Dis.* 17: 409 – 415.
35. Murray, A.G., C.D. Busby, and D.W. Bruno. 2003. Infectious Pancreatic Necrosis Virus in
36. Scottish Atlantic Salmon Farms, 1996 – 2001. *Emerg. Infect. Dis.* [serial online] <http://www.cdc.gov/ncidod/EID/vol9no4/02-0311.htm>.
37. Murray, A.G., R.J. Smith, and R.M. Stagg. 2002. Shipping and the spread of Infectious Salmon Anemia in Scottish Aquaculture. *Emerg. Infect. Dis.* [serial online]. <http://www.cdc.gov/ncidod/EID/vol8no1/01-03144.htm>.
38. OIE, 2003. <http://www.collabcen.net/toWeb/aq2.asp>
39. Okamoto, N., T. Tayama, M.Kawanobe, N.Fujiki, Y. Yasuda, and T. Sano. 1993. Resistance of a rainbow trout strain to infectious pancreatic necrosis. *Aquaculture* 117: 71-76.
40. Olsen, A.B. 2002. Sykdom koster en milliard kroner årlig. 13. november. <http://www.intrafish.no>.
41. Ortega, C., J.L.Múzquiz, J. Docando, E. Planas, J.L. Alonso, and M.C. Simón. 1995. Ecopathology in aquaculture: risk factors in infectious disease outbreak. *Vet. Res.*26: 57 –62.
42. Reno, P.W. 1999. Infectious Pancreatic Necrosis and Associated Aquatic Birnaviruses. In: *Fish Diseases and Disorders*. Vol. 3: Viral, Bacterial and Fungal Infections. Eds. P.T.K. Woo and D.W. Bruno. Pp.: 1-55. CABI Publishing, ISBN 0851991947.
43. Rosseland, B. 2002. Pers. com. Prof. at Norwegian Institute for Water Research.
44. Rønningen, K. and J. Jarpe. 1996. Epidemiologi - en gammel vitenskap med stort brukspotensial i en ny næring. I *Frisk fisk. Om liv og død i merdene*. Universitetsforlaget ISBN 8200226514
45. Skår K 2000. "Parasites and disease of wild fish populations in Norway" Oral presentation at NFR-workshop, Kongsvoll 5-7 June 2000

46. Sommer, A.I. 2001. Intensivt settefiskoppdrett og utbrudd av infeksjøs pankreasnekrose (IPN). Faktaark for prosjekt 133042/120, Havbruksprogrammet, Norges Forskningsråd.
47. Sonstegård, R.A., L.A. McDermott, and K.S. Sonstegård. 1972. Isolation of infectious pancreatic necrosis virus from white suckers (*Catostomus commersoni*). *Nature* 236: 174-175.
48. Smail, D.A., D.W. Bruno, G. Dear, L.A. McFarlane, and K. Ross. 1992. Infectious pancreatic necrosis (IPN) virus Sp serotype in farmed Atlantic salmon, *Salmo salar* L., post-smolts associated with mortality and clinical disease. *J. Fish Dis.* 15: 77–83.
49. Smith, G., J. Bebak, P.E. McAllister. 2000. Experimental infectious pancreatic necrosis infections: propagative or point-source epidemic? *Prev. Vet. Med.* 47: 221-241.
50. St-Hilaire, S., C.S. Ribble, C. Stephen, E. Anderson, G. Kurath, and M.L. Kent. 2002. Epidemiological investigation of infectious hematopoietic necrosis virus in salt water net-pen reared Atlantic salmon in British Columbia, Canada. *Aquaculture* 212: 49–67.
51. Storset, A. 2003. Pers. com. Researcher Aquagen.
52. Taksdal, T., A. Ramstad, K. Stangeland, and B. Dannevig. 1998. Induction of infectious pancreatic necrosis (IPN) in covertly infected Atlantic salmon, *Salmo salar* L., post-smolts by stress exposure, by injection of IPN virus (IPNV) and by cohabitation. *J. Fish Dis* 21: 193–204.
53. Taksdal, T. 2003. Pers. com. Senior Researcher, Norwegian College of Veterinary Medicine
54. Thorburn, M.A. 1987. Factors Influencing Seasonal Vibriosis Mortality Rates in Swedish
55. Pen-Reared Rainbow Trout. *Aquaculture.* 67: 79-85.
56. Thorburn, M.A. 1999. Applying Epidemiology to Infectious Diseases of Fish. In: *Fish Diseases and Disorders. Vol. 3: Viral, Bacterial and Fungal Infections.* Eds. P.T.K. Woo and D.W. Bruno. Pp.: 689 – 722. CABI Publishing, ISBN 0851991947.
58. Thorburn, M.A., G.F. Teare, S. W. Martin, and R. D.Moccia. 200. Group-level factors associated with chemotherapeutic treatment regimes in land-based trout farms in Ontario, Canada. *Prev. Vet. Med.* 50: 165-176.
59. Vik Mariussen, A. 2003. Pers. com., Intervet Norbio.
60. Vågsholm, I., H.O. Djupvik, F.V. Willumsen, A.M. Tveit, and K. Tangen. 1994. Infectious salmon anaemia (ISA) epidemiology in Norway. *Prev. Vet. Med.* 19: 277-290.
61. Wheatley, S.B., M.F. McLoughlin, F.D. Menzies, and E.A. Goodall. 1995. Site management factors influencing mortality rates in Atlantic salmon (*Salmo salar* L.) during marine production. *Aquaculture* 136: 195-207.
62. Willumsen, B. and E. Brun. 1988. Infeksjøs pankreasnekrose (IPN) hos større laksesyngel og smolt. *Nor. Vet. Tids.* 100: 900-901.

## 5. Host-related factors

### 5.1. Persistence

Control of IPN in the salmon fish farming industry should include reduction of IPNV carriers. To do this we need to:



- Increase the knowledge on virus-host interactions. What are the mechanisms behind establishment and maintenance of IPNV persistence? We need to know more about both the virus and the host and their mode of action during infection. How can IPNV infect and replicate in immune cells? Infected salmonids can become carriers for life, indicating that their immune system is not able to clear off the virus. Is it possible to help the immune system of the fish in any way to get rid of the carried virus?
- Clarify what environmental (and other?) conditions that can cause stress-mediated recurrence of IPN.
- Increase the knowledge on cellular immunity in fish and its role in antiviral immunity.
- Clarify the role of vertical transmission in Atlantic salmon and increase the sensitivity and reliability of the carrier tests to be used in brood-stock surveillance. Current knowledge indicates that non-lethal sampling could be a possibility, but this needs to be further investigated.

#### 5.1.1. How is the persistent IPNV infection established and what are the mechanisms behind persistence?

##### 5.1.1.1 *Mode of IPNV transmission*

The mode of IPNV transmission within a hatchery may be a combination of vertical and horizontal transmission. Jarp (1999) reported that in a study from 1996, 9% of the samples from egg yolk fry were IPNV positive, whereas an increasing prevalence was observed in fry and smolt before seawater release. Also, the within-group-prevalence seemed to increase during the freshwater stage, and a higher prevalence was found in 2-year-old smolt than in 1-year-old smolt. Based on the results from Jarp *et al.*'s epidemiological studies, IPNV in farmed Atlantic salmon seem to be introduced by horizontal transmission (Jarp *et al.* 1995, 1996, Jarp 1999) (*see also 4.2.1.*). Vertical transmission has never been directly proven in Atlantic salmon, but it has been described in rainbow trout and brook trout in several reports (Yamamoto 1975, Bullock *et al.* 1976, Hedrick and Fryer, 1982, Ahne and Negele 1985, Mulchay and Pascho, 1984, Dorson and Torchy 1985, Bootland *et al.* 1990, 1991). Covertly infected fish shed virus through seminal and ovarian fluids (Wolf *et al.* 1963, McAllister *et al.* 1993, Bootland *et al.* 1995). Even though the virus is not inside the sexual products, IPNV can adhere to sperm (Mulchay and Pascho 1984, Dorson and Torchy 1985), and egg shell of uninfected eggs (Ahne and Negele, 1985) and thereby cause transmission (3.1.).

### 5.1.1.2 *Where is IPNV hiding?*

No simple answer can be given as to the mechanisms by which IPNV can be carried in fish. The exact site of cellular replication of IPNV is unknown, but the fact that IPNV is most often isolated from the head kidney, a haematopoietic organ, suggests that the virus may be replicating in one or more types of leukocytes. Swanson and Gillespie (1982) showed that IPNV was picked up by phagocytic cells and transported to the kidney following intraperitoneal injection. IPNV in carriers are associated with blood leukocytes (Swanson and Gillespie, 1982, Yu et al. 1982, Ahne and Thomsen, 1986, Saint-Jean et al 1991) and head kidney leukocytes (Rodriguez et al 2001) from trout. Yu et al (1982) used an infection centre assay and found that only a small portion of the adherent blood leukocytes infected *in vitro* produced IPNV in rather high amounts. Co-cultivation of head kidney cells from carrier trout, by which increased sensitivity in detection of carriers is achieved, has also been reported (Hedrick and Fryer 1982, Agius *et al*, 1982, Mangunwiryo and Agius, 1988). Saint-Jean et al. (1991) detected virus antigen in up to 58% of the newly isolated blood leukocytes from carrier trout by flow cytometry. By cultivation for a week this number was significantly increased.

Fewer studies have been performed on Atlantic salmon leukocytes, but Knott and Munro (1986) reported that IPNV was associated with head kidney leukocytes isolated from Atlantic salmon carriers, and that mitogen stimulation increased the number of IPNV positive samples. Furthermore, Johansen and Sommer (1995 a, b) have isolated blood and head kidney leukocytes from Atlantic salmon carrying IPNV. Significant increases in IPNV titres and virus positive cells were found in adherent head kidney leukocytes, mainly macrophages, during 7 days in culture. Initially about 1% of the cell population was infected, which is in agreement with the observations of Hedrick and Fryer (1982) and Yu et al (1982). Blood leukocytes and non-adherent leukocytes did not contribute to virus production and no IPNV positive cells were detected by immunofluorescence in these cells. Both for rainbow trout and Atlantic salmon the leukocyte infections have been reported to be non-lytical (Estepa and Koll 1991, Johansen and Sommer 1995a). This is also in agreement with observations in persistently infected cell lines (Hedrick and Fryer, 1982).

...the exact site of cellular replication of IPNV is unknown...

Johansen and Sommer (1995a) concluded that head kidney adherent leukocytes may be responsible for the IPNV titres detected in head kidneys of Atlantic salmon. Production of virus in macrophages is not unique to IPNV and Atlantic salmon. Although the task of specialised phagocytes, like macrophages, is to engulf and destroy invading microbes, they allow replication of virus from many virus families and genera.

Different methods of cell isolation and virus detection could explain the differences in observation between the salmonid species regarding the amount of cells infected, and which cell types that support an IPNV replication. The various results could also be due to natural variations between species and between families and individuals as well. Further studies are needed to characterise in which cell types IPNV is carried and similarly in which cell types the virus can replicate.

### 5.1.1.3 *Mechanisms behind viral persistence*

Even though viral persistence is well known in many different virus families, the mechanisms of establishing and maintaining persistence are still poorly understood both in animals and humans. In general, for lytical viruses to persist, a restriction of gene



expression or defective interfering particle (DIP production) is necessary. Viral quasi-species, usual among RNA viruses, can escape the immune defence system. Cytotoxic T-lymphocyte-escape mutants are found among several virus families (Tyler and Nathanson 2001). Immunosuppression is considered a prerequisite for persistence. Cytotoxic T-cells are important for control of virus infections, and dysfunction or inactivation of these can lead to persistence. RNA viruses have a high mutation rate and when these involve certain viral peptides, they can interfere with antigen processing or with recognition of MHC/peptide complexes by T-cell receptors (Oldstone 1998). Other mechanisms of establishing persistence can be antibody escape mutants and down-regulation of MHC (Tyler and Nathanson, 2001). Knowledge on cellular immunity and its function in fish antiviral immunity is still sparse, and an increasing effort should be taken to explore this field (5.2.4).

#### 5.1.1.4 Defective interfering particles (DIPs)

DIPs have been postulated to be key elements in disease modulation and persistence. DIPs are virus particles that contain genomes that are grossly altered genetically, usually by significant deletions of essential functions. But they nevertheless retain critical replication origins and packaging signals, allowing for amplification and packaging in coinfections with complementing wild-type “helper” virus. DIPs often display a replication advantage relative to wild-type virus, resulting from increases in the copy-number or efficiency of replication origins. DIPs actively inhibit wild-type virus replication by competing for limiting essential replication factors (Levine, 2001). They have been demonstrated in cell culture experiments by several researchers, also in IPNV infections. However, to date there has been no unequivocal report of the detection of DIPs in natural infections in animals or humans (Kim *et al.* 1999). This can be due to methodological problems. The possibility that DIPs exist in nature has been strengthened by studies with rotavirus, hepatitis virus and influenza virus (Kim *et al.* 1999).

#### 5.1.1.5 The role of DIP`s in IPNV persistence

The first report on persisting IPN virus infections *in vitro* came in 1963 (Moewus and Sigel 1963). Several researchers during the period 1974-1981 reported that persistent infections *in vitro* were due to DIPs (Nicholson and Dunn 1974, Hedrick *et al.* 1978, Macdonald and Yamamoto 1978, Macdonald and Kennedy 1979, Hedrich and Fryer 1981, Kennedy and Macdonald 1982). Hedrick *et al.* (1978) established two persistently infected cell lines. They had the same growth as uninfected cells and were resistant to superinfection with homologous virus. Virus stock harvested from these cell lines had higher amounts of DIPs than those from lytically infected cells. The defective particles had the capacity to suppress or interfere with the growth of their infectious counterparts in co-infected cells. They suggested that DIP might be responsible for the maintenance of the carrier cultures. Macdonald and Kennedy (1979) confirmed that DIP mediated the persistent IPNV infection in cell lines. They also concluded that the interferon system was not involved in persistence. The same authors in 1982 reported that nearly all cells in a persistent cell culture contained virus and that the cells replicated DIP poorly, although they generated DIP at a very high rate and thereby allowed their interfering activity. Nicholson and Dexter (1975) linked DIP to a carrier situation *in vivo*. Organ homogenates from brook trout IPNV carriers at  $10^{-1}$  dilution failed to show any cpe for 72 hours after infection of RTG-2 cultures, while a  $10^{-3}$  dilution exhibited extensive cpe as early as 24 hours after infection. The authors strongly suggested that DIP was the cause of the interference in the most concentrated sample.

Truncated biologically active particles resembling infectious haematopoietic necrosis virus (IHNV) DIPs have been found in rainbow trout surviving an IHNV epizootic, 1 and 2 years after infectious virus was no longer detectable in the fish (Kim *et al.* 1999). DIPs have also been demonstrated after serial passages in cell cultures of infectious bursal disease virus (IBDV), a birnavirus of birds. However, DIPs were rare when IBDV was propagated *in vivo* in the bursa of Fabricius, the target organ of IBDV in chickens (Nagarajan and Kibenge 1997).

#### 5.1.1.6 Anti-IPNV antibodies and IPNV persistence

Anti-IPNV antibodies have been found to have no role in viral persistence (Hedrick and Fryer 1982, Dorson 1983), and antibodies are not sufficient to clear off an IPNV infection (Ahne and Thomsen 1986, Bootland *et al.* 1991, Bootland *et al.* 1995, Melby and Falk 1995). Few studies exist on Atlantic salmon, but there seems to be a wide variance in the humoral immune responses of individual fish and some fish are non-responders. Melby and Falk (1995) found varying levels and individual variations of anti-IPNV antibodies in Atlantic salmon IPNV carriers. No correlation was found between the presence or level of tissue IPNV and plasma antibody level, and samples from many fish were negative or had very low levels of antibodies. Immunisation of adult brook trout with inactivated IPNV did not prevent them from becoming carriers of IPNV, even though a strong humoral immune response was induced. Neutralising anti-IPNV antibody titres had no effect on the prevalence of infection in leukocytes (Bootland *et al.* 1995). Melby (1994) concluded that lack of correlation between anti-IPNV antibodies and IPNV in tissues, and the possibility of immunotolerance to IPNV due to infection early in life, should be studied further (6.2. and 5.2.3.2).

### 5.1.2. Is an IPN virus carrier condition harmful to Atlantic salmon?

#### 5.1.2.1 IPNV persistence and its effects on the host.

Several reports connect the carried IPN virus to immune cells (leukocytes). In rainbow trout Yu *et al.* (1982) isolated IPNV from 75% of the blood leukocyte samples isolated from carriers and found that a small portion of the cells produced rather high amounts of virus. Bootland *et al.* (1995) found that 75% of adult brook trout had leukocytes associated viraemia from 6 weeks until 15 weeks after an IPNV infection, when the last samples were analysed. Rodriguez *et al.* (2001) isolated IPNV from all blood and head kidney leukocyte samples analysed by RT-PCR in a rainbow trout brood-stock carrier population. In Atlantic salmon Knott and Munro (1986) found that Atlantic salmon head kidney leukocytes were carrying IPNV. They also reported that the head kidney leukocytes showed suppressed immune response *in vitro* compared to cells from non-carriers, when stimulated with PHA. Johansen and Sommer (1995 a, b), have shown that IPNV infects and is carried in adherent leukocytes from the head kidney of Atlantic salmon, and that these cells are able to support virus production.

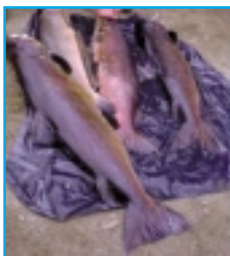

From these findings there is a possibility that carriers have suppressed immune systems, which might not function as well as in non-carriers. However, several *in vivo* studies have demonstrated that a carrier condition with a low or non-detectable virus level, do not seem to affect the immune system in its ability to respond to vaccination or pathogens, or the general health condition of the fish. Bruno and Munro (1989) found that IPNV carriers of Atlantic salmon fry vaccinated against *Y. ruckeri* obtained the same RPS after *Y. ruckeri* challenge as non-carriers. Eggset *et al.* (1997) showed that an IPNV carrier condition in Atlantic salmon did not affect the smoltification process, and vaccinated carriers and non-

carriers were equally well protected against *A. salmonicida* or *V. salmonicida*. Johansen and Sommer (2001) reported that Atlantic salmon carriers of IPNV were not more susceptible to *V. salmonicida* or ISA virus than virus free salmon (2001a). Furthermore, Damsgård *et al.* (1998) reported that an IPNV carrier condition in Atlantic salmon did not affect appetite and weight gain when compared to non-carriers (7.1.). All these reports are from experimental studies.

Smail and Bruno (1985) sampled field data from batches of Atlantic salmon IPNV carriers in two farms at parr-smolt transformation, and later for one year during the post smolt stage. The authors lacked the knowledge of when the fish had been infected, but the infection had never caused any mortality. Unlike results from other studies of covertly infected smolts that were not survivors of IPN epizootics, necrotic tissue was found in some of the fish that were lacking neutralising antibodies. As much as 60-70% of the fish examined had no neutralising antibodies, yet virus was detected in all fish at all times. As reported by Damsgård *et al.* (1998), growth was not influenced by the carrier situation, in spite of the necrotic tissue found in pancreas. They therefore concluded that the digestive function of the pancreas was not heavily affected in these carriers.

#### 5.1.2.2 IPNV carriers can be protected against reinfection.

Sommer and Toften (2001) and Sommer *et al.* (2001) reported in the studies of IPNV reactivation in smolts that were subject to intensive production conditions with poor water



quality for 7 weeks before seawater transfer. The carrier condition was experimentally established 3 months before seawater transfer, and titer studies showed that 100% of the samples tested were IPNV positive at sea water transfer. However, no reactivation occurred during the 6 weeks observation period in seawater. Production conditions that caused significantly higher mortality than in the control groups after

IPNV challenge in seawater, did not affect the IPNV carrier condition. When fish from the carrier group were reinfected with IPNV in seawater, a significant protection was obtained as compared to challenged non-carriers. Only 20% (20/100) died in the reinfected group, while 70% (70/100) died in the challenged non-carrier group. The mechanisms behind this protection were not further analysed, but it could be explained by homologous viral interference or humoral immune response. Interference refers to a phenomenon whereby infection by one virus results in inhibition of replication of another virus. Several distinct types of interference have been described. IPNV has been shown to induce interferon when virus is actively being produced (Dorson *et al.* 1992), and this could also explain the protection obtained. The same virus isolate was used both for the establishment of the carrier condition and for the reinfection. A more interesting approach would have been to reinfect the carriers with a different isolate.

Similar results have been reported by Stangeland *et al.* (1996) and Taksdal *et al.* (1998). Covertly infected smolts reinfected after seawater transfer had significantly lower mortality than groups of covertly infected smolts that were mock infected. The fish they used were natural carriers collected from commercial hatcheries, so a different isolate was used for reinfection, even though analyses using monoclonals did not reveal any differences between the two isolates. Virus was not detected before the experiment started, but 1 out of 90 samples tested was positive for IPNV antibodies in an ELISA. Nearly all samples tested were antibody negative over a period of 6 weeks after challenge and stress treatment by water drainage. The samples were not tested for IPNV neutralising antibodies, but the results from the ELISA suggests that something else than antibodies has to be part of the protective mechanism (4.2.4.).

### 5.1.2.3 Recurrence of IPN

The experiments described confirm that carriers of IPNV under certain circumstances could be protected against reinfection with IPNV. The study of Sommer and Toften (2001) showed that the environmental stress and physiological changes that led to increased mortality in non-carriers, did not reactivate a carrier IPNV.

It is important to note once again that for all these cases the IPNV carriers are seemingly healthy fish with no or very low detectable IPN virus titers. There is either no production of new virus particles, or production at a low rate. A gap of knowledge exists regarding this situation in salmonids, but at this state there seems to be a balance between the virus and its host. The immune system of the fish handles the virus, but it does not get rid of it. However, a carrier situation is not a steady, constant condition. Virus titers fluctuate with time (Billi and Wolf 1969, Hedrick and Fryer 1982, Mangunwiryo and Agius 1988) and several reports supports the assumption that different forms of environmental stress or physiological changes (like the smoltification process) can affect the carrier virus and lead to increased production of virus. In some cases this increased virus production leads to outbreaks of disease and mortality due to IPN.

To my knowledge, the first report on natural stress mediated recurrence of IPN in salmonids came as early as in 1976. Roberts and McKnight reported on 12 cases of losses

...increased virus production from carriers can lead to outbreak of IPN...

of up to 20% in cultured rainbow trout of up to 1 year old. The outbreaks started only 3 days after husbandry stress such as transportation or sudden temperature rise.

The affected fish all came from a stock that had apparently recovered from IPN infection previously. The experience from natural outbreaks (Jarp *et al.*, 1995, 1996, Jarp, 1999) and more recent experimental work on Atlantic salmon is that the first mortalities due to IPN is registered about 3-8 weeks after seawater transfer/treatment. Stangeland *et al.* (1996) and Taksdal *et al.* (1998) demonstrated a stress-mediated recurrence of IPN starting 3 weeks after treatment, using water drainage twice a week as stress method. Their work confirms that viruses the fish carries with them from the fresh water stage cause outbreaks of IPN in post-smolts. However, a primary infection after seawater transfer may also occur, due to the widespread distribution of IPNV in Norwegian fish farms (Melby *et al.* 1991) (4.2.3.).

Johansen and Sommer (2001b) reported that an experimentally established carrier condition, where the virus amount was below detection level at seawater transfer, were reactivated resulting in clinical IPN starting 3 weeks after seawater transfer with 24% cumulative mortality. The fish were not deliberately stressed in any way and experimental conditions regarding water quality, tank density etc. was normal. The cause of the reactivation is thus not known.

### 5.1.2.4 IPNV carriers shed virus.

Even if the virus they are carrying does not affect the fish themselves, these fish shed virus through faeces and sexual products (Wolf *et al.* 1963, Yamamoto 1975, Ahne and Negele 1985, Bootland *et al.* 1986). Stress has been shown to increase shedding of virus in the faeces (Yamamoto 1975, Reno *et al.* 1978, Yamamoto and Kilistoff 1979). Shedded virus can be a threat to other fish, either in the same population or in other stocks of fish, when smolts from different hatcheries are mixed at the sea site. Mixing of smolt groups have been connected with increased risk of IPN in an epidemiological study by Jarp *et al.* (1995). Significantly more fish died due to IPN when smolt groups from different hatcheries were mixed at the sea site, compared to sea sites where no mixing occurred (4.2.3.).



### 5.1.2.5 IPNV carriers increase the risk of IPN epizootics

Together all these findings fully confirm the complexity of the IPNV carrier condition, and show that IPN carriers are indeed a risk factor both to the carriers themselves and to other fish populations. The concluding remark of Roberts and McKnight in 1976 was that their findings suggested that survivors of IPN outbreaks are always a risk to any future stress, and where possible, maintenance of disease-free stock may have long-term as well as short-term advantages. In Norway there has been no systematic control for the last years to reduce the amounts of carriers among brood-stock or progeny (1.3.). With the rather convincing data presented by the researchers mentioned above, we should seriously consider reducing the amounts of carriers in our salmon industry. Furthermore, more knowledge is needed on the virus-host interactions and what environmental conditions that can cause recurrence.

...we should seriously consider reducing the amounts of carriers in our salmon industry...

### 5.1.2.6 IPNV carrier testing.

Covert infections are often not detected by available techniques. It is important to increase the sensitivity of the IPNV carrier tests (2.7.). McAllister *et al.* (1994) carried out studies to determine whether use of elevated water temperature and immunosuppressant stressors (cortisol) could enhance virus titer and perhaps also prevalence of viral infection in carrier brook trout. The prevalence of IPNV positive samples was not significantly higher after treatment, but the titer value after treatment was significantly greater. Taksdal *et al.* (2001) reported that cortisol treatment was not effective in increasing the amount of carriers detected among Atlantic salmon carriers. PCR -based techniques are being developed and hold promise for more sensitive, and perhaps non-lethal, carrier testing in the future (Taksdal *et al.* 2001, Rodriguez *et al.* 2001).

### 5.1.3. References

1. Agius, C. *et al.* 1982. A more sensitive technique for isolating infectious pancreatic necrosis virus from asymptomatic rainbow trout, *Salmo gairdneri* Richardson. J. Fish. Dis. 5; 285-292.
2. Ahne, W. and Negele R.D. 1985. Chapter 26 in Fish and Shellfish Pathology Ed. By Ellis AE Academic Press, London.
3. Ahne, W. And Thomsen, I. 1986. Infectious pancreatic necrosis: detection of virus and antibodies in rainbow trout IPNV-carrier (*Salmo gairdneri*). J. Vet. Med. B. 33; 552-554.
4. Billi, J.L. and Wolf, K. 1969. Quantitative comparison of peritoneal washes and feces for detecting infectious pancreatic necrosis (IPN) virus in carrier brook trout. J. Fish. Res. Bd. Canada 26; 1459-1465.
5. Bootland, L.M. *et al.* 1986. Experimental induction of the carrier state in yearling brook trout; a model challenge protocol for IPNV immunization. Vet. Imm. And Immunopathol. 12; 365-372.
6. Bootland, L.M. *et al.* 1990. Fry age and size effects on immersion immunization of brook trout, *Salvelinus fontinalis* Mitchell, against infectious pancreatic necrosis virus. J. Fish Dis. 13; 113-125.
7. Bootland, L.M. *et al.* 1991. The IPNV carrier state and demonstration of vertical transmission in experimentally infected brook trout. Dis. Aquat. Org. 10; 13-21.
8. Bootland, L.M. *et al.* 1995. Immunization of adult brook trout, *Salvelinus fontinalis* (Mitchell), fails to prevent the infectious pancreatic necrosis virus (IPNV) carrier state. J. Fish Dis. 18; 449-458.
9. Bullock, G.L. *et al.* 1978. Infectious pancreatic necrosis: transmission with iodine-treated and nontreated eggs of brook trout (*Salvelinus fontinalis*). J. Fish. Res. Brd. Can. 33; 1197-1198.
10. Bruno, D.W. and Munro, A.L.S. 1989. Immunity in Atlantic salmon, *Salmo salar* L., fry following vaccination against *Yersinia ruckeri*, and the influence of body weight and infectious pancreatic necrosis virus (IPNV) on the detection of carriers. Aquaculture 81; 205-211.
11. Damsgård B, *et al.* (1998) Effects of infectious pancreatic necrosis virus
12. (IPNV) on appetite and growth in Atlantic salmon, *Salmo salar* L. Aquaculture 163:185-193
13. Dorson M, *et al.* 1992. Interferon synthesis in rainbow trout fry following infection with infectious pancreatic necrosis virus. Fish Shellfish Immunol 2:311-313.



14. Dorson, M. and Torchy, C. 1985 Chapter 25 p. 251-260 in Fish and Shellfish Pathology Ed. By Ellis AE Academic Press, London.
15. Dorson, M. 1983. IPNV of salmonids; overview of current problems. Pp. 7-33 in Antigenes of Fish Pathogens, Eds. Anderson D.P., Dorson, M.M. and Dubourget P. Collection Fondation Marcel Marieux, Lyon, France.
16. Eggset *et al.* 1997. Susceptibility to furunculosis, cold water vibriosis, and infectious pancreatic necrosis (IPN) in post-smolt Atlantic salmon (*Salmo salar* L.) as a function of smolt status by seawater transfer. *Aquaculture* 158; 179-191.
17. Estepa, A. and Coll, J.M., 1991. Infection of mitogen-stimulated trout leukocytes with salmonid viruses. *J. Fish Dis.* 14; 555-562.
18. Hedrick, R.P. and Fryer, J.L. 1981. Persistent infection of three salmonid cell lines with infectious pancreatic necrosis virus (IPNV). *Fish Pathol.* 15; 163-172.
19. Hedrick, R.P. and Fryer, J.L. 1982. Persistent infections of salmonid cell lines with infectious pancreatic necrosis virus (IPNV): a model for the carrier state in trout. *Fish Pathol.* 16(4); 163-172.
20. Hedrick, R.P. *et al.* 1978. Persistent infections in salmonid fish cells with infectious pancreatic necrosis virus (IPNV). *J. Fish Dis.* 1; 297-308.
21. Jarp J. *et al.* (1995) Risk factors for furunculosis, infectious pancreatic necrosis and mortality in post-smolt of Atlantic salmon, *Salmo salar* L. *J Fish Dis* 18:67-78
22. Jarp, J. *et al.* 1996. Infectious pancreatic necrosis in Atlantic salmon *Salmo salar* in relation to specific antibodies, smoltification, and infection with erythrocytic inclusion body syndrome (EIBS). *Dis. Aquat. Org.* 27; 81-88.
23. Jarp, J. 1999. Epidemiological aspects of viral diseases in Norwegian farmed Atlantic salmon (*Salmo salar* L.). *Bull. Eur. Ass. Fish Pathol.* 19 (6); 240-244.
24. Johansen, L.H. and Sommer, A.I. 1995a. *In vitro* studies of infectious pancreatic necrosis virus in leucocytes isolated from Atlantic salmon (*Salmo salar* L.). *Aquaculture*, 132; 91-95.
25. Johansen, L.H. and Sommer, A.I. 1995b. Multiplication of infectious pancreatic necrosis virus (IPNV) in head kidney and blood leucocytes isolated from Atlantic salmon, *Salmo salar* L. *J. Fish Dis.* 18; 147-156.
26. Johansen, L.-H. and Sommer, A.-I. 2001a. Infectious pancreatic necrosis virus infection in Atlantic salmon *Salmo salar* post-smolts affects the outcome of secondary infections with infectious salmon anaemia virus or *Vibrio salmonicida*. *Dis. Aquat. Org.* 47; 109-117.
27. Johansen, L.-H. and Sommer, A.-I. 2001b. Atlantic salmon carrying IPN virus; risk of IPN after seawater transfer. 10<sup>th</sup> int. conf. of the EAAP, Dublin 9<sup>th</sup>-14<sup>th</sup> Sept. 2001
28. Kennedy, J.C. and MacDonald, R.D. 1982. Persistent infection with infectious pancreatic necrosis virus mediated by defective-interfering (DI) virus particles in a cell line showing strong interference but little DI replication. *J. Gen. Virol.* 58; 361-371.
29. Kim, C.H. *et al.* 1999. Truncated particles produced in fish surviving infectious hematopoietic necrosis virus infection: mediators of persistence? *J. Virol.* 73 (1); 843-849.
30. Knott RM, and Munro ALS (1986) The persistence of infectious pancreatic necrosis virus in Atlantic salmon. *Vet Immunol Immunopathol* 12:359-364
31. Levine, A.J. 2001. The origins of virology. In *Virology*, Eds. Knipe and Howley /Lippincott Williams and Wilkins Philadelphia USA
32. MacDonald, R.D. and Kennedy, J.C. 1979. Infectious pancreatic necrosis virus persistently infects chinook salmon embryo cells independently of interferon. *Virology* 95; 260-264.
33. MacDonald, R.D. and Yamamoto, T. 1978. Quantitative analysis of defective interfering particles in infectious pancreatic necrosis virus preparations. *Arch. Virol.* 57; 77-89.
34. Mangunwiryo, H. and Agius, C. 1988. Studies on the carrier state of infectious pancreatic necrosis virus infections in rainbow trout, *Salmo gairdneri* Richardson. *J. Fish Dis.* 11; 125-132.
35. McAllister *et al.* 1993. Determining the prevalence of infectious pancreatic necrosis virus in asymptomatic brook trout *Salvelinus fontinalis*: a study of clinical samples and processing methods. *Dis. Aquat. Org.* 15; 157-162.
36. McAllister, P.E. *et al.* 1994. Effects of elevated water temperature and immunosuppressant treatment on prevalence and titer of infectious pancreatic necrosis virus in naturally infected brook trout. *J. Aquat. Animal Health* 6; 133-137.
37. Melby HP 1994. IPNV; antigenic variation and aspects of the epidemiology of the infection, Dr. scient thesis Norwegian College of Veterinary Medicine
38. Melby HP and Falk K (1995) Study of the interaction between a persistent infectious pancreatic
39. necrosis virus (IPNV) infection and experimental infectious salmon anaemia (ISA) in Atlantic salmon, *Salmo salar* L. *J. Fish Dis.* 18; 579-586.

40. Melby HP *et al.* 1991. All commercial Atlantic salmon seawater farms in Norway harbour carriers of infectious pancreatic necrosis virus (IPNV). In: Fryer JL (ed) Proceedings from the 2<sup>nd</sup> International Symposium on Viruses of Lower Vertebrates, Oregon State University, Corvallis, OR: p 211-217
41. Moewus, L. and Siegel, M.M. 1963. In vivo and in vitro cultivation of a fresh water fish virus in marine host systems. *Bacteriol. Proc.* 26:135.
42. Mulcahy, D. and Pascho, R.J. 1984. Adsorption to fish sperm of vertically transmitted fish viruses. *Science* 225; 333-335.
43. Nagarajan, M.M. and Kibenge, F.S.B. 1997. Infectious Bursal Disease virus. A review of molecular basis for variations in antigenicity and virulence. *Can. J. Vet. Res.* 61; 81-88.
44. Nicholson, B.L. and Dexter, R. 1975. Possible interference in the isolation of IPN virus from carrier fish. *J. Fish. Res. Bd. Can.* 32; 1437-1439.
45. Nicholson, B.L. and Dunn, J. 1974. Homologous viral interference in trout and atlantic salmon cell cultures infected with infectious pancreatic necrosis virus. *J. Virol.* 14 (1); 180-182.
46. Nicholson, B.L. and Dexter, R. 1975. Possible interference in the isolation of IPN virus from carrier fish. *J. Fish. Res. Brd. Can.* 32; 1437-1439.
47. Oldstone 1998 Mechanisms of establishment and maintenance of viral persistence *Curr. Opin. Microbiol.* p. 436-441.
48. Reno, P.W. *et al.* 1978. Infectious pancreatic necrosis; experimental induction of a carrier state in trout. *J. Fish. Res. Brd. Can.* 35; 1451-1456.
49. Roberts RJ, and McKnight IJ 1976. The pathology of infectious pancreatic necrosis virus. II. Stress-mediated recurrence. *British Vet J* 132:209-213
50. Rodriguez, S. *et al.* 2001. Detection of infectious pancreatic necrosis virus (IPNV) from leukocytes of carrier rainbow trout *Oncorhynchus mykiss*. *Fish Pathol.* 36 (3); 139-146.
51. Saint-Jean, S. *et al.* 1991. Detection of infectious pancreatic necrosis in a carrier population of rainbow trout, *Oncorhynchus mykiss* (Richardson), by flow cytometry. *J. Fish. Dis.* 14; 545-553.
52. Smail DA and Bruno ALS. 1985. IPNV persistence in farmed Atlantic salmon. Chapter 28 in *Fish and Shellfish Pathology* Ed. by Ellis A.E., Academic Press, London.
53. Sommer, A.I. and Toften, H. 2001, Intensivt settefiskoppdrett og utbrudd av infeksjons pankreas nekrose (IPN). Faglig sluttrapport, NFR prosjektnr. 133042/122.
54. Sommer, A.I., *et al.* 2001. Sammenhenger mellom intensivt drift og IPN utbrudd hos smolt. *Norsk Fiskeoppdrett*, 60-62
55. Stangeland K. *et al.* 1996. Experimental induction of infectious pancreatic necrosis in Atlantic salmon, *Salmo salar* L., post-smolts. *J Fish Dis* 19: 323-327.
56. Swanson, R.N. and Gillespie, J.H. 1982. Isolation of infectious pancreatic necrosis virus from the blood and blood components of experimentally infected trout. *Can. J. Fish. Aquat. Sci.* 39; 225-228.
57. Taksdal *et al.* 1998. Induction of infectious pancreatic necrosis (IPN) in covertly infected Atlantic salmon, *Salmo salar* L., post-smolts by stress exposure, by injection of IPN virus (IPNV) and by cohabitation. *J. Fish is.* 21; 193-204.
58. Taksdal, T. *et al.* 2001. Detection of infectious pancreatic necrosis (IPN)-virus in experimentally infected Atlantic salmon parr by RT-PCR and cell culture isolation. *Bull. Eur. Fish Pathol.* 21 (5): 214-219.
59. Tyler and Nathanson, 2001, Persistent infections. In *Virology*, Eds. Knipe and Howley /Lippincott Williams and Wilkins Philadelphia USA
60. Wolf, K. *et al.* 1963. Egg-associated transmission of IPN virus of trouts. *Virology* 21; 317-321.
61. Wolf, K. and Quimby, M.C. 1969. Infectious pancreatic necrosis: Clinical and Immune response of adult trouts to inoculation with live virus. *J. Fish. Res. Bd. Can.* 26; 2511-2516.
62. Yamamoto T. 1975. Infectious pancreatic necrosis (IPN) virus carriers and antibody production in a population of rainbow trout (*Salmo gairdneri*). *Can J Microbiol* 21: 1343-1347.
63. Yamamoto, T. and Kilstoff, J. 1979. Infectious pancreatic necrosis virus: quantification of carriers in lake populations during a 6-year period. *J. Fish. Res. Brd. Can.* 36; 562-567.
64. Yu, K.K.-Y. *et al.* 1982. Replication of infectious pancreatic necrosis virus in trout leukocytes and detection of the carrier state. *J. Fish. Res. Brd. Can.* 39; 401-410.

## 5.2. Antiviral mechanisms in fish

- Are outbreaks of IPN related to down regulation of innate defence-mechanisms? Can immunostimulants, such as poly I:C and CpGs, which activate the interferon system, be used as prophylactic treatments to prevent disease outbreaks?
- Can differences in virulence between strains and isolates of IPNV be linked to the virus' ability to resist and evade innate antiviral mechanisms? Is a virulent IPNV isolate able to inhibit the type I IFN response in Atlantic salmon, while a low virulent strain does not have such effective mechanisms for inhibiting this response?
- Could specific antiviral proteins that are able to actually inhibit IPNV replication, such as the Atlantic salmon Mx protein, be used as parameters in breeding of salmon resistant to IPNV?
- Do other innate defence systems, such as type II IFN, TNF $\alpha$  and NK-cells, demonstrate antiviral activity against IPNV?
- IPNV induces a specific antibody response in salmonids, but what is the role of these antibodies in eradication of and mediating protection against IPNV?
- Cell-mediated immunity is known, from mammals, to be important in virus infections. What is the role of cell-mediated immunity in an IPNV infection?



### 5.2.1. Innate immunity

Innate immunity provides the first lines of defence against infections and is rapidly activated before a specific immune response develops. The mechanisms of innate immunity against viruses limit spread of the viral infection and also modulate the specific immune response to be more effective against viruses. How well infectious agents resist or evade the mechanisms of innate immunity is partly related to their pathogenicity (1). In fish, innate immune mechanisms are expected to be particularly important. Adaptive, specific immune responses take several weeks to develop at cold temperatures and innate defence mechanisms can provide protection much more rapidly (16). Understanding the mechanisms involved in first line of defence against virus infections in fish is still at its early stages and thus limited information is available regarding the effects of innate immunity on IPNV in salmonids. However, learning more about these mechanisms may help us understand why salmonids are susceptible to IPNV and how we can obtain fish more resistant to virus infections.

The major mechanisms of innate immunity against viruses are, from mammals, known to involve the cytokines type I interferon (IFN $\alpha/\beta$ ), type II IFN (IFN $\gamma$ ) and tumor necrosis factor  $\alpha$  (TNF $\alpha$ ). These cytokines have the potential to activate intracellular pathways, which can interfere with steps in virus replication. They also recruit and activate natural

killer cells (NK-cells), which can lyse and kill virus infected cells, thus preventing viral multiplication (4). In salmonids the type I IFN system is quite well characterised and some information exists regarding its function as an antiviral system. However, information about type II IFN and TNF $\alpha$  in salmonids is very limited. We know that these cytokines are present in salmonids, but little information exists about these as antiviral agents. As for NK-cells, fish have cells with cytotoxic activity, which is characteristic of mammalian NK-cells, but their function in antiviral defence is not much investigated. The following will thus describe recent advances in research on the type I IFN-system of salmonids.

#### 5.2.1.1 *The type I IFN-system in salmonids*

For many years it has been known that salmonids demonstrate responses that resemble the activity of mammalian type I IFN cytokines. This activity is induced by either live or inactive viruses or by treatment with the synthetic double stranded RNA, poly I:C. The type I IFN-like activity of salmonids is also able to induce protection of cells against homologous and heterologous viruses (16) which are characteristics of mammalian type I IFNs as well. However, very recently a cDNA encoding Atlantic salmon type I IFN gene was cloned. Studies showed that it had antiviral activity and its expression was induced by poly I:C (3). This important achievement makes more specific studies of the salmonid type I IFN-system possible.

...recently a cDNA encoding an Atlantic salmon type I IFN gene was cloned...

The type I IFNs exert their antiviral activity by inducing expression of genes which proteins are able to inhibit virus replication. In salmonids, some genes that are induced by poly I:C or virus infection have been cloned and studied, Mx genes (40, 49, 50), Vig-1 and Vig-2 (8, 9), interferon regulatory factors (10) and MHC class I (11). Little information exists on what specific functions these proteins have and whether they participate in antiviral defence in salmonids. Other well known mammalian antiviral proteins, as protein kinase R (PKR) and 2'-5'- oligoadenylate synthetase, have not been cloned from salmonids, although there are indications that they exist (17, 52).

Since salmonid type I IFN genes have not been available until very recently, expression of Mx genes and proteins have been used as molecular markers of type I IFN responses (39). Four days after i.p injection of Atlantic salmon with poly I:C, Mx protein expression is found in several organs demonstrating the rapid activation of this system and its potential as a powerful innate defence system also in fish (21).

#### 5.2.2. Antiviral effects on IPNV

*Does the salmonid type I IFN system demonstrate any antiviral effects against IPNV?*

This has been studied *in vitro*, in cell cultures. By pretreating cells with poly I:C or supernatants with type I IFN-like activity the putative antiviral mechanisms will be present when the cells later are infected with the virus. It is then possible to compare the virus infection in untreated cells and the treated cells to investigate whether antiviral effects are obtained. In Atlantic salmon cell lines treated with poly I:C or with supernatants with type I IFN-like activity the production of IPNV Sp strain was reduced below detection level (from 10<sup>6</sup> to less than 2 virus particles) compared to untreated control cells (23). For comparison, production of infectious salmon anaemia virus (ISAV) was only reduced 3-5 fold after the same treatments. This demonstrates that IPNV Sp is very sensitive to the antiviral mechanisms induced by poly I:C or type I IFN-like activity in these cells. Recent *in vitro* studies, in Chinook salmon embryo cells (CHSE-214), where the Atlantic salmon

Mx1 protein was expressed as a transgene, replication of IPNV Sp was inhibited (33). This demonstrates that the Atlantic salmon Mx1 protein is able to inhibit replication of IPNV Sp. In cells from other salmonids poly I:C treatment has also been shown to reduce IPNV replication (34), and IPNV is routinely used by researchers in an antiviral assay with CHSE-214 cells as a system to detect type I IFN-like activity (22, 29, 30, 39).

To investigate if antiviral effects are observed *in vivo* a similar approach is often used. Fish is injected with poly I:C before virus challenge and mortality is observed and compared to a control group. Poly I:C-injection of salmonids has been shown to cause delayed onset of mortality and reduced cumulative mortality compared to controls when challenged with ISAV or infectious haematopoietic necrosis virus (15, 21). Very little is known about the effects on IPNV *in vivo*. However, a recent study showed reduced cumulative mortality of Atlantic salmon injected with poly I:C seven days before challenge with IPNV compared to control fish (28). This indicates that the antiviral mechanisms induced by poly I:C *in vitro* also are effective against IPNV *in vivo*.

...IPNV is very sensitive to the antiviral mechanisms induced by poly I:C...

Certain short bacterial DNA sequences containing unmethylated CpG dinucleotides in the context of certain flanking sequences have been shown to be powerful activators of innate immune defences in mammals. Recent studies have shown that this is the case also in Atlantic salmon. Macrophages from Atlantic salmon stimulated with deoxyoligonucleotides containing CpG motifs secrete type I IFN-like activity (29, 30) and *in vivo* CpG deoxyoligonucleotides mediate a non-specific IFN-like protection against IPNV infection (28).

*What happens during an IPNV infection? Activation of antiviral pathways or is the virus able to resist or evade these mechanisms?*

Very few studies have addressed these questions. In IPNV-infected rainbow trout fry IFN-like activity was found in serum and expression of the Mx gene was induced in head kidney cells by IPNV, indicating that the virus activates the type I IFN system in rainbow trout (8, 14). Whether IPNV induces the IFN-system in Atlantic salmon has not been specifically addressed, however an ongoing IPNV infection provided some protection against challenge with ISAV which may indicate that IFN was produced in response to the IPNV infection (25).

It is well known from mammalian studies that different viruses and even different strains of the same virus demonstrate varying sensitivities to the antiviral effects of type I IFNs and also vary in their IFN-inducing capacity (18). This often reflects the virus' ability to resist and evade antiviral mechanisms. Can this be linked to differences in virulence between strains and isolates of IPNV? Is a virulent IPNV isolate able to inhibit the type I IFN response in Atlantic salmon, while a low virulent strain does not have such effective mechanisms for inhibiting this response? Preliminary studies of IPNV infection in Atlantic salmon macrophages indicate this (45), however more research is required in this field.

It is now known that it is possible to treat Atlantic salmon *in vivo* with type I IFN-inducers, like poly I:C or CpGs, to reduce cumulative mortality due to IPNV (28). We also know that IPN outbreaks often occur after seawater transfer, but we do not know whether this can be related to down-regulation of defence mechanisms due to stress. It would be of great interest to examine whether it would be possible to use the IFN-inducers, or the



Atlantic salmon IFN itself as prophylactic treatments to prevent IPNV outbreaks in stressed fish.

The identification of specific antiviral proteins, which are able to actually inhibit IPNV replication, such as the Atlantic salmon Mx protein, makes it possible to use these genes as parameters in breeding of salmon resistant to IPNV. It would also be important to identify the molecular interactions between viral proteins and cellular, putative antiviral proteins.

Recently, a more sensitive and specific method for measuring type I IFN in fish was established compared to the previously used method (24). This shows that studying innate defence mechanisms contributes to development of new, more efficient and sensitive, methods for measuring immune parameters in fish.

### 5.2.3. Specific immunity to IPNV in salmonids

#### 5.2.3.1 *The specific immune system*

The specific immune system is characterised by specificity and memory. It is able to distinguish between specific molecules on pathogens and mount a response against that particular pathogen. Typically a specific immune response against one pathogen will be ineffective against a different pathogen, and sometimes even a closely related, but still different pathogen. It takes several days or weeks for the immune system to learn how to mount an effective, specific response. The specific immune system has memory and this shortens response time when it is exposed to the same pathogen a second time. The specific immune system includes humoral and cell-mediated immunity. Humoral immunity is regulated by B-lymphocytes and the antibodies they produce. Antibodies bind to pathogens and kill or inactivate them in several ways. Cell-mediated immunity is controlled by T-lymphocytes that have the ability to recognise and kill cells infected with pathogens, such as viruses.

It is known from mammals that cell-mediated immune mechanisms are particularly important in elimination of virus-infected cells (51). However in fish, cell-mediated immunity has been poorly investigated due to the lack of methods for measuring this response. The humoral immune response has been studied to a much larger extent in fish. With regard to IPNV in salmonids some information exists on humoral antibody responses, but no information exists on T-cell mediated immune responses.



#### 5.2.3.2 *Humoral immune response to experimental and natural IPNV infections*

Some studies have investigated whether IPNV is able to induce an antibody response in salmonids. Experimental infection of adult rainbow trout and brook trout with live IPNV induces production of neutralising antibodies in serum (6, 13, 27, 53). A maximum antibody response was found 12 weeks after infection (27, 53), but antibody responses have been detected as long as 15 and 19 months after infection (2, 6). Inoculation with inactivated IPNV in adjuvant is also able to mount a specific neutralising antibody response in rainbow and brook trout (5, 31, 41). In Atlantic salmon, injection of live IPNV N1 induced an antibody response, but the neutralising activity of this serum was not investigated. The antiserum was shown to recognise proteins corresponding to the structural IPNV-proteins VP2 and VP3, however little cross reaction with the heterologous IPNV strains Ab, Sp and Jasper was demonstrated (19) (see also 6.2 and 5.1.1.6).

Does the humoral immune response play any role in mediating protection against IPNV? Passive immunisation is one way of determining the protective effects of antibodies. Serum from an individual exposed to IPNV can be transferred and injected into an unexposed individual and then challenged. This has not been extensively investigated with regard to IPNV. However, some works have studied the correlation between presence of IPNV and anti-IPNV antibodies in salmonids (12, 35, 36, 42, 54), but contradictory results have been obtained. Yamamoto and Mangunwiryo (35, 54) observed a decline in the number of virus isolations when the level of anti-IPNV antibodies in a population of rainbow trout increased. Based on these observations they suggested that the antibody response might be important for eradication of the virus. However, others have shown that the virus coexists with neutralising antibodies for a long time and there is no association between detection of IPNV and the presence or level of anti-IPNV antibodies in individual fish (2, 6, 36, 42). An antibody response seems not to be able to prevent establishment of, or remove, a carrier condition. On the other hand, an established carrier state has been shown to provide protection against reinfection with IPNV in Atlantic salmon (46, 47), indicating that other types than humoral immune mechanisms may be important in mediating immunity to IPNV.

A common observation in several of the mentioned studies is the large variation in level of antibody response between individual fish. Some fish are high responders while others are none-responders. No explanations for this have been proposed, but in some studies the large individual variations make it difficult to observe differences between experimental groups.

#### 5.2.4. Cell-mediated immunity

Since viruses are intracellular pathogens, cell-mediated immunity is known to be particularly important (51). Cytotoxic T-lymphocytes are able to recognise virus-infected cells and kill them, thus preventing replication of the virus. Recent studies suggest that antigen specific cytotoxic T-cells are present in fish and that this system has functional similarities to mammalian systems (37), (7,43). In carp it has been shown specific cell-mediated cytotoxicity against IPNV-infected syngeneic cells (44). However, this is the only information available regarding cell-mediated immune responses against IPNV in fish. As summarised above there is no clear answer as to how important antibody responses are in mediating immunity to IPNV. The data may indicate that other mechanisms are involved. Studies of cell-mediated immunity will potentially require inbred lines of fish and cell lines and methods to measure or evaluate the activity of cell-mediated immune responses. For salmonids these tools are not available and a major effort should be put into developing these necessary tools. This would be of key importance in understanding the immune response to IPNV.

...no clear answer as to how important antibody responses are to IPNV...

#### 5.2.5. Immunosuppression

It is known that viruses often have the ability to induce immunosuppression. For IPNV some have speculated that immunosuppression may contribute to the establishment of persistent infection and a carrier state. A few reports exist where it has been investigated whether IPNV is immunosuppressive. Macrophages and leukocytes from salmonids infected with IPNV *in vitro* show reduced capability to respond to stimulation (26, 38) (5.1.2.1). Leukocytes isolated from Atlantic salmon and rainbow trout infected with IPNV *in vivo* show reduced response to mitogens *in vitro* (32, 48). Macrophages isolated from

IPNV-infected Atlantic salmon show reduced capability to produce intracellular O<sub>2</sub><sup>-</sup> compared to uninfected macrophages. This reduced functionality of macrophages correlated with high virus production (20). Increased mortality was obtained when Atlantic salmon with acute IPN was infected with *Vibrio salmonicida* compared to fish infected with *Vibrio salmonicida* alone, demonstrating that an ongoing IPNV infection may increase the risk of secondary bacterial infections (25). Summarised, these results suggest that IPNV has immunosuppressive effects in salmonids, however this seems not to be the case when the amount of IPNV is low (20,25). Further consequences of immunosuppressive effects of IPNV have not been investigated.

### 5.2.6. References

1. Abbas, A., A. Lichtman, and J. Pober. 2000. Cellular and Molecular Immunology, 4th ed. W.B. Saunders Company, Philadelphia.
2. Ahne, W., and I. Thomsen. 1986. Infectious Pancreatic Necrosis - Detection of Virus and Antibodies in Rainbow-Trout Ipnv-Carrier (*Salmo-Gairdneri*). Journal of Veterinary Medicine Series B-Zentralblatt Fur Veterinarmedizin Reihe B-Infectious Diseases and Veterinary Public Health 33:552-554.
3. Robertsen, B, Bergan, V, Røkenes, T, Larsen, R and Albuquerque, A. 2003 Atlantic salmon interferon genes: Cloning, sequence analysis, expression and biological activity. Journal of Interferon and Cytokine Research 23, 601-612
4. Biron, C. A. 1999. Initial and innate responses to viral infections--pattern setting in immunity or disease. Curr Opin Microbiol 2:374-81.
5. Bootland, L. M., P. Dobos, and R. M. W. Stevenson. 1995. Immunization of Adult Brook Trout, *Salvelinus-Fontinalis* (Mitchill), Fails to Prevent the Infectious Pancreatic Necrosis Virus (Ipnv) Carrier State. Journal of Fish Diseases 18:449-458.
6. Bootland, L. M., P. Dobos, and R. M. W. Stevenson. 1991. The Ipnv Carrier State and Demonstration of Vertical Transmission in Experimentally Infected Brook Trout. Diseases of Aquatic Organisms 10:13-21.
7. Boudinot, P., S. Boubekour, and A. Benmansour. 2001. Rhabdovirus infection induces public and private T cell responses in teleost fish. Journal of Immunology 167:6202-6209.
8. Boudinot, P., P. Massin, M. Blanco, S. Riffault, and A. Benmansour. 1999. vig-1, a new fish gene induced by the rhabdovirus glycoprotein, has a virus-induced homologue in humans and shares conserved motifs with the MoaA family. Journal of Virology 73:1846-1852.
9. Boudinot, P., S. Salhi, M. Blanco, and A. Benmansour. 2001. Viral haemorrhagic septicaemia virus induces vig-2, a new interferon-responsive gene in rainbow trout. Fish & Shellfish Immunology 11:383-397.
10. Collet, B., G. C. J. Hovens, D. Mazzoni, I. Hirono, T. Aoki, and C. J. Secombes. 2003. Cloning and expression analysis of rainbow trout *Oncorhynchus mykiss* interferon regulatory factor 1 and 2 (IRF-1 and IRF-2). Developmental and Comparative Immunology 27:111-126.
11. Dijkstra, J. M., Y. Yoshiura, I. Kiryu, K. Aoyagi, B. Kollner, U. Fischer, T. Nakanishi, and M. Ootake. 2003. The promoter of the classical MHC class I locus in rainbow trout (*Oncorhynchus mykiss*). Fish Shellfish Immunol 14:177-85.
12. Dixon, P. F. 1996. Use of antibody screening for the identification of rainbow trout carriers of infectious pancreatic necrosis virus in a broodstock management scheme:preliminary study. Bulletin of the European Association of Fish Pathologists 16:125-128.
13. Dixon, P. F., and J. deGroot. 1996. Detection of rainbow trout antibodies to infectious pancreatic necrosis virus by an immunoassay. Diseases of Aquatic Organisms 26:125-132.
14. Dorson, M., P. De Kinkelin, and C. Torchy. 1992. Interferon synthesis in rainbow trout fry following infection with infectious pancreatic necrosis virus. Fish & Shellfish Immunology 2:311-313.
15. Eaton, W. D. 1990. Antiviral Activity in 4 Species of Salmonids Following Exposure to Poly Inosinic - Cytidylic Acid. Diseases of Aquatic Organisms 9:193-198.
16. Ellis, A. E. 2001. Innate host defense mechanisms of fish against viruses and bacteria. Developmental and Comparative Immunology 25:827-839.
17. Garner, J. N., B. Joshi, and R. Jagus. 2003. Characterization of rainbow trout and zebrafish eukaryotic initiation factor 2alpha and its response to endoplasmic reticulum stress and IPNV infection. Dev Comp Immunol 27:217-31.

18. Goodbourn, S., L. Didcock, and R. E. Randall. 2000. Interferons: cell signalling, immune modulation, antiviral response and virus countermeasures. *J Gen Virol* 81:2341-64.
19. Havarstein, L. S., C. Endresen, B. Hjeltnes, K. E. Christie, and J. Glette. 1990. Specific Immunoglobulins in Serum from Atlantic Salmon, *Salmo-Salar L*, Immunized with *Vibrio-Salmonicida* and Infectious Pancreatic Necrosis Virus. *Journal of Fish Diseases* 13:101-111.
20. Husgard, S. 1996. Studier av uspesifikke forsvarmekanismer hos atlantehavslaks ved infeksjøs pankreas nekrose virus (IPNV) infeksjoner ved immunstimulering. MSc thesis. University of Tromsø.
21. Jensen, I., A. Albuquerque, A. I. Sommer, and B. Robertsen. 2002. Effect of poly I : C on the expression of Mx proteins and resistance against infection by infectious salmon anaemia virus in Atlantic salmon. *Fish & Shellfish Immunology* 13:311-326.
22. Jensen, I., R. Larsen, and B. Robertsen. 2002. An antiviral state induced in Chinook salmon embryo cells (CHSE-214) by transfection with the double-stranded RNA poly I : C. *Fish & Shellfish Immunology* 13:367-378.
23. Jensen, I., and B. Robertsen. 2002. Effect of double-stranded RNA and interferon on the antiviral activity of Atlantic salmon cells against infectious salmon anemia virus and infectious pancreatic necrosis virus. *Fish & Shellfish Immunology* 13:221-241.
24. Johansen, A., E. B. Collett, B. Sandaker, C. J. Secombes, and J. B. Jørgensen. 2003. Quantification of Atlantic salmon type-I interferon using an Mx1 promoter reporter gene assay. *Fish and Shellfish Immunology* In press doi:10.1016/S1050-4648(03)00060-3.
25. Johansen, L. H., and A. I. Sommer. 2001. Infectious pancreatic necrosis virus infection in Atlantic salmon *Salmo salar* post-smolts affects the outcome of secondary infections with infectious salmon anaemia virus or *Vibrio salmonicida*. *Diseases of Aquatic Organisms* 47:109-117.
26. Johansen, L. H., and A. I. Sommer. 1995. In-Vitro Studies of Infectious Pancreatic Necrosis Virus-Infections in Leukocytes Isolated from Atlantic Salmon (*Salmo-Salar L*). *Aquaculture* 132:91-95.
27. Jørgensen, P. E. 1973. The nature and biological activity of IPN virus neutralizing antibodies in normal and immunized rainbow trout (*Salmo gairdneri*). *Arch Gesamte Virusforsch* 42:9-20.
28. Jørgensen, J., L. Johansen, K. Steiro, and A. Johansen. 2003. CpG DNA induces protective antiviral immune responses in Atlantic salmon (*Salmo salar L.*), *Journal of Virology* 77:11471-11479.
29. Jørgensen, J. B., A. Johansen, B. Stenersen, and A. I. Sommer. 2001. CpG oligodeoxynucleotides and plasmid DNA stimulate Atlantic salmon (*Salmo salar L.*) leucocytes to produce supernatants with antiviral activity. *Developmental and Comparative Immunology* 25:313-321.
30. Jørgensen, J. B., J. Zou, A. Johansen, and C. J. Secombes. 2001. Immunostimulatory CpG oligodeoxynucleotides stimulate expression of IL-1 beta and interferon-like cytokines in rainbow trout macrophages via a chloroquine-sensitive mechanism. *Fish & Shellfish Immunology* 11:673-682.
31. Kelly, R., and O. Nielsen. 1990. Serological properties of neutralizing antibodies induced by vaccination of rainbow trout with distinct strains of infectious pancreatic necrosis virus. *Journal of Aquatic Animal Health* 2:56-60.
32. Knott, R. M., and A. L. Munro. 1986. The persistence of infectious pancreatic necrosis virus in Atlantic salmon. *Vet Immunol Immunopathol* 12:359-64.
33. Larsen, R., and B. Robertsen. 2003. Unpublished.
34. Macdonald, R. D., and J. C. Kennedy. 1979. Infectious Pancreatic Necrosis Virus Persistently Infects Chinook Salmon Embryo Cells Independent of Interferon. *Virology* 95:260-264.
35. Mangunwiryo, H., and C. Agius. 1988. Studies on the carrier state of infectious pancreatic necrosis virus infections in rainbow trout, *Salmo gairdneri* Richardson. *Journal of Fish Diseases* 11:125-132.
36. Melby, H. P., and K. Falk. 1995. Study of the interaction between a persistent infectious pancreatic necrosis virus (IPNV) infection and experimental infectious salmon anaemia (ISA) in Atlantic salmon, *Salmo salar L*. *Journal of Fish Diseases* 18:579-586.
37. Nakanishi, T., U. Fischer, J. M. Dijkstra, S. Hasegawa, T. Somamoto, N. Okamoto, and M. Ototake. 2002. Cytotoxic T cell function in fish. *Dev Comp Immunol* 26:131-9.
38. Novoa, B., A. Figueras, and C. J. Secombes. 1996. Effects of in vitro addition of infectious pancreatic necrosis virus (IPNV) on rainbow trout *Oncorhynchus mykiss* leucocyte responses. *Veterinary Immunology and Immunopathology* 51:365-376.
39. Nygaard, R., S. Husgard, A. I. Sommer, J. A. C. Leong, and B. Robertsen. 2000. Induction of Mx protein by interferon and double-stranded RNA in salmonid cells. *Fish & Shellfish Immunology* 10:435-450.
40. Robertsen, B., G. Trobridge, and J. A. Leong. 1997. Molecular cloning of double-stranded RNA inducible MX genes from Atlantic salmon (*Salmo salar L.*). *Developmental and Comparative Immunology* 21:397-412.
41. Sano, T., K. Tanaka, and S. Fukuzaki. 1981. Immune response in adult trout against formalin-killed concentrated IPNV. *Developments in Biological Standardization* 49:63-70.

42. Smail, D. A., and A. L. S. Munro. 1985. Infectious Pancreatic Necrosis Virus Persistence in Farmed Atlantic Salmon, p. 278-288. *In* A. E. Ellis (ed.), *Fish & Shellfish Pathology*. Academic Press.
43. Somamoto, T., T. Nakanishi, and N. Okamoto. 2002. Role of specific cell-mediated cytotoxicity in protecting fish from viral infections. *Virology* 297:120-7.
44. Somamoto, T., T. Nakanishi, and N. Okamoto. 2000. Specific cell-mediated cytotoxicity against a virus-infected syngeneic cell line in isogeneic ginbuna crucian carp. *Dev Comp Immunol* 24:633-40.
45. Sommer, A. I. 2003. Pers.com
46. Sommer, A. I., and H. Toften. 2001. Intensivt settefiskoppdrett og utbrudd av infeksjøs pankreas nekrose (IPN). Sluttrapport for Norges Forskningsråds prosjekt nr. 133042/122. Fiskeriforskning.
47. Taksdal, T., A. Ramstad, K. Stangeland, and B. H. Dannevig. 1998. Induction of infectious pancreatic necrosis (IPN) in covertly infected Atlantic salmon, *Salmo salar* L., post smolts by stress exposure, by injection of IPN virus (IPNV) and by cohabitation. *Journal of Fish Diseases* 21:193-204.
48. Tate, H., H. Kodama, and H. Izawa. 1990. Immunosuppressive Effect of Infectious Pancreatic Necrosis Virus on Rainbow-Trout (*Oncorhynchus-Mykiss*). *Japanese Journal of Veterinary Science* 52:931-937.
49. Trobridge, G. D., P. P. Chiou, and J. A. C. Leong. 1997. Cloning of the rainbow trout (*Oncorhynchus mykiss*) Mx2 and Mx3 cDNAs and characterization of trout Mx protein expression in salmon cells. *Journal of Virology* 71:5304-5311.
50. Trobridge, G. D., and J. A. C. Leong. 1995. Characterization of a Rainbow-Trout Mx-Gene. *Journal of Interferon and Cytokine Research* 15:691-702.
51. Whitton, J. L., and O. M.B.A. 2001. The Immune Response to Viruses, p. 285-320. *In* D. M. Knipe and P. M. Howley (ed.), *Fields Virology*, 4th ed, vol. 1. Lippincott Williams & Wilkins, Philadelphia.
52. Wiens, M., A. Kuusksalu, M. Kelve, and W. E. Muller. 1999. Origin of the interferon-inducible (2'-5')oligoadenylate synthetases: cloning of the (2'-5')oligoadenylate synthetase from the marine sponge *Geodia cydonium*. *FEBS Lett* 462:12-8.
53. Wolf, K., and M. C. Quimby. 1969. Infectious Pancreatic Necrosis - Clinical and Immune Response of Adult Trouts to Inoculation with Live Virus. *Journal of the Fisheries Research Board of Canada* 26:2511.
54. Yamamoto, T. 1975. Infectious pancreatic necrosis (IPN) virus carriers and antibody production in a population of rainbow trout (*Salmo gairdneri*). *Can J Microbiol* 21:1343-7.



## 6. Vaccination

- Despite very high industrial research and sales activity, a remarkable lack of quality scientific publication of results allowing for reliable judgement about vaccine efficacy or protective mechanisms
- Unpublished data from clinical studies suggest that there is a specific protective effect of vaccines containing IPNV antigen against virulent IPNV challenge, in addition to a non-specific protective effect induced by multivalent, oil adjuvanted vaccines. As of yet, no clear evidence for superior performance of any particular vaccine formulation or product has been presented.
- There are several epidemiological studies suggesting that there are no measurable protective effects from IPN vaccines. I am not convinced of this conclusion because these studies leave numerous open questions regarding data collection and quality assurance, and the techniques used for statistical analysis.
- There is no evidence that inclusion of IPNV antigens into salmon vaccines *per se* would induce more aggravated injection-site lesions.
- In an attempt to clarify the stakeholder's vision about IPN vaccines, the aquaculture industry should stimulate the scientific publication of clinical studies on the efficacy and protective capacities of IPN vaccines. Individual farming companies will unlikely be able to produce sufficient demand for such change to happen. Joint industry bodies (like the FHF) should consider collaborative efforts with the pharmaceutical industry and/or commissioning independent studies allowing for publication. To circumvent potential bias induced by fish strain or IPN isolate, a multicentre study using fish of different genetic origin and at least 3 representative virulent IPNV clones/isolates is recommended. A realistic evaluation of principally new technology solutions for IPN vaccination (for example oral booster immunisation) should be stimulated by the aquaculture industry.
- Projects evaluating passive immunisation techniques for salmon fry should be stimulated, because it represents a principally novel application of immunoprophylaxis with a potentially important role in the total control strategy for IPN along the value chain. The same goes for vaccination or treatment of broodfish with immunosera prior to artificial reproduction, in order to minimise risks for vertical transfer of IPNV.
- Serum transfer studies should be carried out to assess the presence and role of humoral immunity to IPN (reproduction and confirmation of findings by Agniel 1975).
- Further research to characterise the humoral and cellular immune responses present in salmon having acquired specific immunity to IPN is needed.



The most striking finding of the current review is a remarkable lack of publications presenting results from IPN vaccination studies in peer reviewed scientific journals. At the second international symposium on Fish Vaccinology in Oslo, Christie (1997) reviewed the state-of-the art of IPN vaccination, summarising IPN vaccine research up to then. This review gave some new information from the development of an IPN-VP2 recombinant protein antigen that since 1995 were included in multivalent vaccines being commercially available in Norway. Since then, three original papers presenting in greater detail the results referred to in this review have been published, namely Frost and Ness (1997), Biering (1997) and Frost et al. (1998). The thesis by Frost (1999) containing amongst others his 1997 and 1998 article should also be mentioned. Another summary of the state-of-the-art in IPN vaccination was published by Fausa Pettersen (1997) in Norwegian language the same year. Besides this, one article coming out of a different research group gives some information about antibody responses in fish immunised with IPNV antigen (Labos et al. 2001). The remaining published information on IPN vaccination is scarce, and mainly in the form of conference abstracts or commercial advertisement materials.

As pointed out in Christie's review, vaccines against IPNV were launched under



provisional marketing authorisation in Norway during 1995, and various multivalent formulations with IPN antigen component have since then been commercially available. In Norway alone, at least eight yearclasses (10-12 distinct smolt cohorts) of Atlantic salmon have been immunised with IPN-vaccines in the field. The IPN vaccine coverage among the Norwegian 2002 Atlantic salmon smolts is estimated to be above 80% (Brun, this report),

with even higher coverage in certain regions such as Mid-Norway (Bruheim 2002). During the period since 1995, several new products (a new formulation series of the recombinant IPN-VP2 antigen and two competitor vaccine series, both based on inactivated IPN virus) have been developed and launched. This implies the conduct of rather extensive experimental studies for documentation and batch quality testing, which until now have only partially been presented at scientific meetings. It is obvious that there exists a wealth of raw data potentially allowing for scientific studies on anti-IPN vaccination both within the pharmaceutical industry, and within the Norwegian aquaculture industry.

### 6.1. Protective effects and parameters of immunity after IPN vaccination

Indicators of protection after immunising Atlantic salmon parr with multivalent, oil adjuvanted vaccine containing an unstated amount of recombinant IPNV antigen (rVP2) produced in *E. coli* (Norvax Protect-IPN) was first reported by Frost et al. (1995) and later published (Frost and Ness 1997). Salmon pre-smolts weighing between 20 and 30 g were immunised. The trial included saline injected control fish, and controls immunised with the same vaccine formulation lacking the rVP2 component (Norvax Protect). After 10 weeks, the fish were challenged by intraperitoneal inoculation with  $1.9 \times 10^6$  TCID<sub>50</sub> cell culture grown IPNV strain N1. From the start of the trial, each group was periodically sampled for virus isolation and for determination of anti-IPNV antibodies using an ELISA. The challenge failed, but IPNV was isolated from only 2 out of 50 fish belonging to the IPN vaccinated group as compared to 28 out of 50 in the saline injected group, and 16 out of 50 in the group that had received vaccine without IPNV antigen. In the rVP2-immunised group, anti-IPNV antibodies were found in the majority of fish (31 out of 50) sampled between 1 –12 weeks post-challenge as compared to a significantly lower proportion (10 out of 50) of response in the saline injected group. Titres in the IPN immunised fish were

high and occurred between 4-6 weeks post-challenge, whereas the humoral antibodies in the non-immunised fish occurred later and were first evident 12 weeks after challenge. The paper does not, however, give any information regarding potential correlation between Ab responses and virus isolation in individual fish.

In conclusion, this study demonstrated that immunising Atlantic salmon with vaccine containing rVP2 would elicit faster and higher antibody responses to IPNV challenge, and support virus clearance, both features likely valuable for the protection of individual fish and fish populations against disease outbreaks. Direct evidence for disease protection was, however, not demonstrated.

Another group, Cekaite and Aas-Eng (2001) have later confirmed that monovalent IPN vaccine formulations based upon inactivated virus, in particular when adding CpG as an adjuvant, would also lead to increased clearance of virus from the head kidney and a strong stimulation of anti-IPNV antibody responses after challenge.

A rather detailed analysis of the antibody responses of Atlantic salmon to rVP2 antigen was provided by Frost et al. (1998). In this study, 20g salmon parr were held at 10°C and immunised i.p. with 100 µg purified rVP2 in 0,1 ml PBS. The control group received HBSS. When fish were sampled 8 weeks thereafter, sera from the rVP2 immunised group showed strong reactivity with the recombinant antigen, and a significantly weaker reactivity with whole virus particles. An opposite pattern (strong reactivity to IPNV particles, and weaker reactivity to rVP2) was found in a pooled serum from IPN challenge survivors that were sampled for reference. Western Blot confirmed that all sera from the immunised group recognised both rVP2 and VP2 purified from IPNV, whereas the reference serum also recognised IPNV-VP3. Both the hyperimmune reference serum and sera from rVP2 immunised fish were able to form immunocomplexes with IPNV, but only the reference serum were able to neutralise IPNV using an *in vitro* cell culture assay. Referring in the discussion to unpublished results with lower antigen doses giving no responses, and also considering the antibody responses seen in rabbits, the authors concluded that the rVP2 was rather poorly immunogenic and only partially able to induce antibodies reacting with the VP2 epitope(s) from native IPNV. No evidence was found for direct neutralisation of virus by anti-rVP2 antibodies. No conclusion could be drawn as regarding a potential role of opsonising anti-VP2 antibodies in protection against infection or disease. The main finding of the study remained the demonstration of a priming of the humoral immune response via immunisation with rVP2 (*see also 5.1.1.6 and 5.2.3.2*).

## 6.2. Antibody responses in Atlantic halibut

A trial of nearly identical design performed with 13-15 months old (46-100g) Atlantic halibut, *Hippoglossus hippoglossus* was reported by Biering (1997). Groups of fish were immunised with multivalent, oil adjuvanted salmon vaccine with or without rVP2 antigen or with viral growth medium (HBSS). No clear primary antibody response against whole IPNV was found in either group by ELISA 9 weeks after immunisation, although there was some reactivity in all groups at a low dilution (1:400) One week later, the fish were challenged with IPNV strain N1 by bath without induction of mortality, inducing a strong antibody response in all groups starting 2-4 weeks thereafter. The serum antibody levels of all groups rose to yield an absorbance of 2.0 (1:6400) until 12-14 weeks post-challenge. At this time point, the sera from all groups also exerted a strong but highly variable

...there was no correlation between virus clearance and anti-IPNV antibody levels of individual fish...

immunised with multivalent, oil adjuvanted salmon vaccine with or without rVP2 antigen or with viral growth medium (HBSS). No clear primary antibody response against whole IPNV was found in either group by ELISA 9 weeks after immunisation, although there was some reactivity in all groups at a low dilution (1:400) One week later, the fish were

neutralising effect on the cell culture infectivity of IPNV N1. Western Blot analysis revealed variable reactivity to 4 MW bands of IPNV but without any group-specific pattern. IPNV was isolated in high titers from all groups 2-6 weeks after challenge and thereafter dropped through week 14, without any statistically significant pattern. There was no correlation between virus clearance and anti-IPNV antibody levels of individual fish.

This pattern of antibody responses and virus clearance led the author to conclude that the observed responses in halibut were likely non-specific. He also suggest that the experimental fish, despite being sero- and virus-negative, may have been exposed to IPNV prior to commencement of the trial and that the observed response of all groups to challenge was a secondary response. A measurable secondary response to immunisation with rVP2 antigen was, however, not proven.

In a study comparing the recombinant expression of truncated IPNV-VP2 protein in four difference cellular expression systems, Labus et al. (2001) found that Atlantic salmon immunised with these recombinant antigens emulsified in a non-mineral oil adjuvant mounted a measurable albeit weak humoral antibody response against whole IPNV particles, thus confirming the results obtained earlier by Frost et al. (1998).

### 6.3. Effect of IPNV or IPNV antigen on abdominal adhesions in vaccinated salmon

In an experimental study to identify risk factors for severe post-vaccinal adhesions, 30g Atlantic salmon pre-smolts were inoculated with live IPN-virus 14 days before they were intraperitoneally vaccinated with a trivalent, oil-adjuvanted bacterin (Colquhoun et al. 1998). Co-infection with IPNV did not affect the severity of abdominal vaccine lesions as determined by necropsy 1, 2 and 3 months after vaccination, whereas co-injection with live *Pseudomonas fluorescens*, and to a lesser degree the application of periodical crowding stress did aggravate the abdominal lesions. Based on these results, concurrent IPNV infection was not considered a risk factor for side effects when vaccinating Atlantic salmon parr. Largely these findings have been corroborated by another group (Berg et al. 1999, Hansen et al. 1999, Berg et al. 2003) reporting that Atlantic salmon parr vaccinated with Norvax Protect-IPN at various time points during autumn and winter exhibited average abdominal lesion scores between 1.5 to 3.0 on the "Speilberg" scale when sampled as adults. As compared to common findings in the Norwegian industry, these scores are deemed on average, presenting no evidence for any particular risk arising from the IPNV antigen included in the vaccines.



### 6.4. Interpretation of epidemiological data

Several independent epidemiological studies conducted in Norway during the years 1997-2002 have provided information on IPN vaccination and have attempted to analyse the outcome of IPN vaccination in the field. These studies have until now been presented in a rather brief format in Norwegian language with limited distribution. Likely due to the lack of thorough scientific processing and presentation, there is however a continued dispute among Norwegian scientists and fish health workers regarding the interpretation of the information they contain and to which degree the methods used are adequate for drawing firm conclusions (4.1.6).



Bruheim (1998) reported the first results from an epidemiological questionnaire survey regarding the 1997-smolt yearclass, where data on IPN vaccination were included and processed. Information on the fate of the spring output smolts during approximately 4-6 months following sea transfer (until September 30) was collected. The dataset comprised information from 120 marine farming sites along the coastline from Rogaland (south) to Nordland (north), in total approximately 31,2 mill smolts belonging to 138 groups, of which 88 (63,3%) were vaccinated against IPN whereas 51 (36,7%) were immunised with vaccines lacking an IPN antigen component. The risk for IPN outbreaks was higher in IPN-vaccinated than in IPN-unvaccinated groups, but the IPN vaccinated groups experienced lower overall losses from sea transfer to September 30 whether or not the site had experienced a clinical outbreak of IPN. The differences in outbreak risk or mortality between various IPN-vaccines were small and non-significant. Because the results within the groups were highly variable and the limited number of observations per groups rendered the differences statistically non-significant, the author was reluctant to draw any firm conclusions based upon the results.

In another, independently conducted study reported by Ersdal and Jarp (1999), a representative selection of fish groups transferred to sea were sampled for investigations on the prevalence of cataracts and vaccine lesions during the summer of 1998. 51 groups for which retrospective information was collected regarding vaccine status and disease history were sampled (for materials and methods; see Ersdal et al. 2001). In this material, the risk for IPN outbreak was apparently equally high in IPN vaccinated and IPN-unvaccinated groups. When breaking the data down on vaccine product used, however, a difference in outbreak incidence and mortality pattern was revealed, leaving one of the vaccines clearly in favour of the other. No indications for increased severity of abdominal lesions were found in groups immunised with vaccine containing IPNV antigens.

The following year, a more comprehensive epidemiological survey commissioned by the vaccine manufacturer Intervet Norbio AS was conducted and reported by Brun (1999). The results showed that 68% of the spring entry cohort and 53% of the autumn entry cohort were immunised with vaccines containing IPNV antigen, but that there had been a major shift in market share between products as compared to the year before. The author concluded that the data yielded no overall evidence that IPN vaccination *per se* nor using specific vaccine products would reduce IPN outbreak risk, IPN-specific mortality or time from seawater entry to outbreak. This interpretation of the data was strongly influenced by an imbalanced representation of various IPN vaccine products, and the author pointed out one vaccine based upon recombinant protein antigen performed remarkably well in a well-balanced subset of data provided by one of the fish health services.

Later years, reports based upon the principal method and format of Bruheim (1998) have been provided annually, covering the mid-Norwegian coastal area (Bruheim 2000, 2001, 2002). An increasing proportion of the Atlantic salmon smolts put to sea in the area of investigation have been immunised with multivalent vaccines containing IPNV antigen, the 2001 yearclass estimate reaching 96,3%. When interpreting the results from 1998-2001 in conjunction, the author indicates that there is a certain protective effect of IPN vaccines, but that the performance of distinct vaccine products seems to vary from year to year (Bruheim 2002) (4.1.6 Table 2).

..."indicates a certain protective effect of IPN vaccines"....."it is concluded that IPN vaccines do not improve protection"...



An unpublished but very comprehensive epidemiological study on potential protective effects of IPN vaccination has been made available by the author (Brun, 2001). Based upon a questionnaire survey among fish health services, during which data were retrospective collected about IPN outbreaks, IPN vaccination status and numerous other relevant factors among the year 2000 cohort of Norwegian farmed Atlantic salmon, the author has produced a very thorough and comprehensive analysis using modern statistical methods for analytical epidemiology. It is concluded that IPN vaccines do not improve protection against IPN, but it is noted that the efficacy analysis shows a quite strong regional divergence that cannot be explained. Maybe the author has not managed to efficiently adjust for the major confounding factor of the study, namely the association between the actual IPN outbreak risk (as indicated by a site's or a farm's history of IPN outbreaks) and the choice of the farm owner a) to vaccinate and b) which vaccine to use. The latter choice is also introducing strong bias to the study, via regional differences in market penetration by competing vaccine manufacturers. Albeit not being published, the scientific quality of design, data collection and quality assurance of this study allows for a potentially fruitful discussion and dispute about which statistical method is most appropriate, and how the results from various statistical analyses might be processed differently to ensure correct interpretation.

In a recently published epidemiological study on IPN in Scottish aquaculture, no results pertaining to IPN vaccination are contained (Murray et al. 2003).

In conclusion, the epidemiological studies show that multivalent vaccines containing IPNV antigen of either quality is clearly insufficient to effectively prevent outbreaks of clinical IPN in post-smolts, given the current epizootic situation in Norwegian salmon farming. Although the data are apparently conflicting, several and independent datasets indicate that at least some of the IPN vaccines will provide reduced mortality, thus suggesting that IPN vaccination is worthwhile and cost-effective. The confusion is to a large degree caused by the lack of proper scientific study design, analysis and quality assurance of available data.

One should add that because of the recent dominant market share of IPNV-antigen containing vaccines, high quality epidemiological studies are becoming increasingly difficult to conduct in Norway. For the future this may no longer be an appropriate method for assessing IPN vaccine efficacy. Clinical field studies using marked, IPN-unvaccinated sub-populations will therefore likely be a more promising alternative for future studies.



### **6.5. Clinical studies on vaccine efficacy using experimental or field challenge**

Up to now, results from clinical vaccine efficacy studies with successful experimental or field challenge, have been presented only at scientific conferences and meetings or as confidential product information. The outcome of a few trials has been published in aquaculture magazines or in the form of scientific/technical product information by commercial companies.

In an oral presentation at Fiskeriforskning's anniversary seminar in 1998, Ann-Inger Sommer (1998) presented 2 successful IPN vaccination-and challenge trials showing 100% relative protection and ca. 66% relative protection, induced by a recombinant IPN-VP2 vaccine formulation. Good protection by another vaccine formulation containing the same vaccine antigen was also reported in a Norwegian fish and animal health research

conference by Knappskog et al. (1999), who indicated relative protection estimates of 66-72% at very high (96%) mortality among the control fish.

Shivappa et al. (2002) reported the development of a recombinant subunit vaccine for IPN using a baculovirus/ insect larvae system and the conduct of clinical trials in rainbow trout fry. This year, the same group have presented some clinical data (Shivappa et al. 2003) showing that IPNV challenge of vaccinated Atlantic salmon pre-smolts gave 39% mortality after 4 weeks, vs. 77% in the control group. Pre-smolts immunised with a lower dose showed 60% mortality vs. 84% in the control fish.

Recently, Ramstad and Midtlyng (2003a) reported on the development of a bath challenge model for IPN where several commercially available vaccines were evaluated in 4 trials involving Atlantic salmon parr. Variable control mortality was obtained dependent on fish strain, but in all trials the mortality among vaccinated groups was consistently and significantly lower than in the unvaccinated controls. However, a detailed analysis of these data (Ramstad and Midtlyng 2003b) revealed that in 2 of the trials in which the control mortality reached more than 65%, only one IPN vaccine formulation (containing recombinant VP2 protein produced in *E. coli*) gave significant protection versus a multivalent reference bacterin lacking IPNV antigen. In the remaining 2 trials where control mortality was 35%, all vaccines (both those containing IPN antigen and the reference product) provided non-specific protection when compared to the unvaccinated controls.

In a well-controlled field study reported by Erdal et al. (2003), two IPN-vaccinated groups of Atlantic salmon showed 50,6 and 53,2 % relative protection during a natural outbreak of IPN 6 weeks after sea transfer. One of these groups displayed significantly elevated antibody levels 6 weeks after vaccination, whereas the other did not. No information was given as to the specificity of the protection observed in this study.

#### 6.6. Commercial information about IPN vaccines

Being forced by law to refrain from presenting scientific data on product performance towards the public, commercial publications by the pharmaceutical industry normally state the companies' interest in and development of IPN vaccines without giving any efficacy or safety information (Alpharma AS, Aqua Health Europe Ltd, Microtek International, Schering-Plough AH, Intervet Norbio).

Among relevant commercial publications should be mentioned Johnsen (2002) reporting that IPNV vaccinated salmon receiving an immunostimulatory diet containing  $\beta$ 1,3/1,6 glucan prior to IPNV challenge were moderately protected compared to fish receiving reference diets (28% vs. 35 or 38% cumulative mortality) (7.3). In the conclusions of this article, it is stated that IPN vaccinated fish experienced a lower mortality than unvaccinated fish, suggesting that additional, unvaccinated groups were included in the trial. Confidential data show that survival was lower among unvaccinated groups (Biotec AHN, 2003). These data are apparently the source of another article (anonymous, 2002) appearing in the Norwegian Skretting-customer magazine "På mærkanten". An earlier information leaflet from the same feed company (Skretting anonymus, undated) claims that a group of IPN-vaccinated S1/2 smolts receiving "Respons" feed have lower cumulative mortality from September to April, vs. an IPN-unvaccinated group of fish receiving the same feed. This information is however presented without the necessary information on study design as to ascertain their validity (7.4).

Most of the recent clinical results on IPN vaccination made available during this review have come in the form of confidential information materials for use in customer contact meetings, lacking a scientific format. Apparently, there is no demand for scientific-quality documentation on IPN vaccines from aquaculture industry customers, thus failing to stimulate the pharmaceutical industry to pursue scientific publishing of results. The confidential nature of the information made available (Alpharma 2003, ScanVacc 2003, Aquaculture Vaccines 2001, Intervet Norbio 1998, 1999) and the lack of details allowing for an independent scrutiny of the results makes a detailed review of this material inappropriate. In my opinion, the industrial data warrant the following overall summary:

- All vaccine manufacturers are able to present data (albeit in different volume and detail) showing examples that IPN vaccines induce significant and partly high protection against experimental IPNV challenge.
- Trials also show that multivalent, adjuvanted bacterins without IPNV antigen will give some protection against IPN challenge, but clearly less than IPN vaccines.
- Most of the manufacturers are able to present at least one study suggesting that their product is at least equally protective compared to one or more reference products.
- There is no way to critically assess the validity of the various results without detailed information about materials and methods and data processing being given in scientific format.

Based upon this material, the conclusion is that IPN vaccines do provide specific protection and that there are strong indications that at least one vaccine provides significant specific protection against IPN. However, too little information is provided to validate the magnitude of protection under field condition, the ranking between vaccine products or other aspects essential to the industrial farming situation. The apparent divergence of results may, at least in part, originate from differences in genetically determined susceptibility of experimental fish to IPN, or differences in virulence between challenge isolates. Both are factors for which there is ample biological evidence and which may introduce bias when comparing studies on IPN vaccination.

### **6.7. Further and forthcoming reports on IPN vaccine/vaccination studies**

The activity of a European research consortium attempting to develop a recombinant and DNA vaccines against IPN was presented by Vaughan et al. (1997, 1998). This group reported the development of a DNA vaccine plasmid including the IPN-VP2 gene, and a live alphavirus vector vaccine for delivery of recombinant IPNV-DNA, but without presentation of substantial results. *In vitro* immune responses were, however, measured without yielding exciting results stimulating publication (Reitan LJ, 1999). More recent and successful results showing that salmon can be protected against IPN by DNA vaccination is being advertised (Genomar AS) and data confirming this success have been presented at a recent scientific meeting (Rimstad 2003).

Based upon oral and poster presentation at the Fish Vaccinology symposium in Bergen 9-11 April this year, and the EAFP Conference in Malta in September 2003, the scientific presentation of more clinical trials showing the efficacy of IPN vaccination is anticipated and should be awaited with great interest (Rødseth 2003, Erdal et al. 2003, Ramstad and Midtlyng, 2003b).

## 6.8. References

1. Agneil LD (1975). An assessment of passive transfer of immunity to infectious pancreatic necrosis virus (IPNV) in trout. MS thesis, The American University, Washington DC, USA.
2. Berg A, Rødseth OM and Hansen T (1999). Effekt av vaksinetidspunkt, lysperiode og vekstrate på immunrespons og bivirkning av vaksinerings på laks. Fiske- og dyrehelsemøtet NFR, Tromsø, 18-20 januar 1999, p. 76.
3. Berg A, Rødseth OM and Hansen T (2003). Time of vaccination influences development of adhesions, growth and spinal deformities in Atlantic salmon (*Salmo salar* L.). Book of abstracts, 3<sup>rd</sup> International IABS symposium on fish vaccinology, Bergen 9-11 April 2003, p. 59.
4. Biering E (1997). Immune response of the Atlantic halibut (*Hippoglossus hippoglossus* L.) to infectious pancreatic necrosis virus (IPNV). *Fish & Shellfish Immunology* 7: 137-149.
5. Cekaite L and Aas-Eng (2001) Effects of immune stimulators and adjuvants on protection of Atlantic salmon against infectious pancreatic necrosis virus (IPNV). Programme and abstracts, 5<sup>th</sup> Nordic Fish Immunology Symposium, Sundvolden 18-22 June 2001, p. 33.
6. Christie KE (1997). Immunization with viral antigens: infectious pancreatic necrosis. *Developments in Biological Standardisation* 90: 191-199
7. Colquhoun DJ, Skjerve E, Poppe TT (1998). *Pseudomonas fluorescens*, infectious pancreatic necrosis virus and environmental stress as potential factors in the development of vaccine related adhesions in Atlantic salmon, *Salmo salar* L. *Journal of Fish Diseases* 21: 355-364.
8. Erdal JI, Skjelstad B and Soleim KB (2003). Evaluation of protection from vaccination against infectious pancreatic necrosis (IPN) in a GCP field trial in Norway. Book of abstracts, 11<sup>th</sup> Conference of the EAAP, Malta 21-25 Sept 2003, O-103.
9. Ersdal C, Midtlyng PJ and Jarp, J (2001). An epidemiological study of cataracts in seawater farmed Atlantic salmon *Salmo salar*. *Diseases of Aquatic Organisms* 45, 229-236.
10. Fausa Pettersen E (1997). Infeksiøs pankreasnekrose virus (IPNV) og vaksineutvikling [Infectious pancreatic necrosis virus (IPNV) and the development of viral vaccines] In Norwegian with English summary. *Norsk veterinærtidsskrift* 109 (8/9): 499-506.
11. Frost P (1999). Infectious pancreatic necrosis virus – epitope mapping and vaccine development. Dr. Scientiarum Thesis University of Bergen. ISBN 82-7653-016-8.
12. Frost P, Børsheim K and Endresen C (1998). Analysis of the antibody response in Atlantic salmon against recombinant VP2 of infectious pancreatic necrosis virus (IPNV). *Fish & Shellfish Immunology* 8: 447-456.
13. Frost P and Ness A (1997). Vaccination of Atlantic salmon with recombinant VP2 of infectious pancreatic necrosis virus (IPNV), added to a multivalent vaccine, suppresses viral replication following IPNV challenge. *Fish & Shellfish Immunology* 7: 609-619.
14. Frost P, Ness A, Maaseide NP, Knappskog DH and Rødseth OM (1995). Efficacy of a recombinant vaccine against infectious pancreatic necrosis in Atlantic salmon post-smolt. Book of abstracts, 7<sup>th</sup> International EAAP Conference "Diseases of Fish and Shellfish" Palma de Mallorca, 10-15 Sept 1995, p. 164.
15. Hansen, E-K, Hansen T, Rødseth OM, Wergeland H and Berg A (1999). Effekt av temperatur på sammenvoksnings hos vaksinert laks. Fiske- og dyrehelsemøtet NFR, Tromsø, 18-20 januar 1999, p. 41.
16. Knappskog DH, Sommer AI and Rødseth OM (1999). Using a laboratory IPNV challenge model (immersion) for Atlantic salmon (*Salmo salar*) to evaluate the efficacy of different vaccine formulations. Fiske- og dyrehelsemøtet NFR, Tromsø, 18-20 januar 1999, p. 41.
17. Labus MB, Breeman S, Ellis AE, Smail DA, Kervick M and Melvin WT (2001). Antigenic comparison of a truncated form of infectious pancreatic necrosis (IPN) virus expressed in four different cell types. *Fish & Shellfish Immunology* 11; 203-216.
18. Murray AG, Busby CD and Bruno DW (2003). Infectious pancreatic necrosis virus in Scottish Atlantic salmon farms 1996-2001. *Emerging Infectious Diseases* 9 (4) 455-460.
19. Ramstad A and Midtlyng PJ (2003a). Consistency of an IPNV bath challenge model in normal and out-of season Atlantic salmon smolts. Book of abstracts, 3<sup>rd</sup> International IABS symposium on fish vaccinology, Bergen 9-11 April 2003, p. 93.
20. Ramstad A and Midtlyng PJ (2003b): Validation of a bath challenge model for IPN vaccines in Atlantic salmon. Book of abstracts, 11<sup>th</sup> Conference of the EAAP, Malta 21-25 Sept 2003, O-102.
21. Rødseth OM (2003). Update on viral vaccines for fish. Oral presentation, 3<sup>rd</sup> International IABS symposium on fish vaccinology, Bergen 9-11 April 2003.05.13
22. Shivappa RB, McAllister PA and Vakharia V (2002) A subunit vaccine for infectious pancreatic necrosis virus using a baculovirus/insect larvae system. Proceedings from the 4th International Symposium, on Aquatic Animal Health, New Orleans 1-5 Sept 2002, p. 178.

23. Shivappa RB, McAllister PE, Santi N, Evensen Ø and Vakharia V (2003) Development of a subunit vaccine for IPNV using a baculovirus insect/larvae system. Book of abstracts, 3<sup>rd</sup> International IABS symposium on fish vaccinology, Bergen 9-11 April 2003, p. 51 and oral presentation (ibid.)
24. Singer JT, Edgar JH and Nicholson BL (1998). Expression of capsid proteins from infectious pancreatic necrosis virus (IPNV) in the marine bacterium *Vibrio anguillarum*. Marine Sea Grant – New developments in Marine Biotechnology, vol 68, 303-306.
25. Vaughan et al. 1998: Genetic immunisation of fish. Proceedings from the 3<sup>rd</sup> European Marine Science and Technology Conference Lisbon (Portugal) May 23-27, 1998. p. 206.

#### Reports and technical publications

26. Bruheim T (1998). Utbredelse og betydning av sykdommen IPN hos laks i settefisk og matfiskanlegg i Norge i 1997. Veterinærinstituttet, Trondheim 13 p.
27. Brun E (1999). Utbredelse og betydning av sykdommen IPN hos laks i norske settefisk og matfiskanlegg 1998. Veterinærinstituttet, Oslo 25 p.
28. Brun E (2001). A field study to evaluate vaccination against infectious pancreatic necrosis in sea farmed Atlantic salmon (*Salmo salar* L.) in Norway. MSc. thesis, National Veterinary Institute, Oslo. 44p.
29. Bruheim T A (2000). Utbredelse og betydning av sykdommen IPN hos laks i matfiskanlegg i Midt-Norge og på Nord-Vestlandet i 1999. Veterinærinstituttet, Trondheim 8p.
30. Bruheim T (2001). Utbredelse og betydning av sykdommen Infeksiøs pancreasnekrose (IPN) hos laks i matfiskanlegg i Midt-Norge og på Nord-Vestlandet i 2000, Veterinærinstituttet, Trondheim 8p.
31. Bruheim T (2002). Utbredelse og betydning av sykdommen Infeksiøs pancreasnekrose (IPN) hos laks i matfiskanlegg i Trøndelag og Nord-Møre i 2001, Veterinærinstituttet, Trondheim 6p.
32. Erdsdal C and Jarp J (1999). En epidemiologisk studie av vaksineskader hos norsk oppdrettslaks - statistisk rapport. Veterinærinstituttet, Oslo, 20 p.
33. Sommer AI (1998). Virussykdommer hos laksefisk. Presentasjon på Fiskeriforsknings jubileumsseminar 1-3 September 1998.
34. Sommer AI, Knappskog DH and Rødseth OM (1998). Ny smittemodell for IPN – et viktig bidrag i kampen mot sykdommen. Norsk fiskeoppdrett nr 18, 30-32.

#### Commercial publications

35. anonymus (2002). Respons reduserer dødeligheten ved IPN-utbrudd. På Mærkanten nr 2/2002 s. 14.
36. Alpharma AS (anonymus Feb 2002). Alpharma Aquatic Products expand its activities in Chile. Press release 1 p.
37. Aqua Health Europe Ltd. (anonymus, undated). Product News – Infectious Pancreatic Necrosis. URL: <http://www.aquahealth.co.uk/news.htm>.
38. Microtek International (anonymus, undated). Recombinant infectious pancreatic necrosis vaccine. URL: <http://www.microtek-intl.com/research/Temp/IPNV/>
39. Genomar AS (Anne-Lill Hellemann 04.11.2002). Fish Health. URL: [http://www.genomar.com/about\\_vaccines.asp](http://www.genomar.com/about_vaccines.asp)
40. Johnsen M (2002). Kampen mot IPN. I dybden vol 18, (2), 293-296.
41. Skretting AS (anonymus, undated). Dokumentasjon Repons: feltforsøk på Frøya fra høsten 1995 til våren 1996. Information leaflet, 1 p.

#### Confidential materials

42. Alpharma AS (Anne Aas-Eng 2003). Presentation materials on ALPHA JECT 6100 and ALPHA JECT 6-2 for fish health personnel (confidential).
43. Aquaculture Vaccines, Ltd. (Robert Wardle 2001). Interim report from a GCP field trial with AquaVac FV4-IPN Multivalent and AquaVac IPN Oral (confidential).
44. Aquaculture Vaccines, Ltd. (Robert Wardle 2001). Field trial report on the use of AquaVac FNM+IPN Multivalent and AquaVac IPN Oral (confidential)
45. Biotec AHN (Maja Johnsen 2003). Information materials, study protocol and raw data on the effects of MacroGard® as feed ingredient on survival of Atlantic salmon after IPNV challenge (confidential).
46. Intervet Norbio (Anne Vik Mariussen 1998) Feltefaringer med Norvax Protect-IPN. Product information materials for fish health personnel (confidential).
47. Intervet Norbio (Irene Nygård 1999) Product information materials on Norvax Compact 5 and Norvax Protect-IPN for fish health personnel (confidential).



48. Intervet Norbio (Cato Lyngøy 1999) Ny produktserie fra Intervet Norbio – Norvax Compact. Product information materials for fish health personnel (confidential).
49. Intervet Norbio (Cato Lyngøy 1999) Feltdokumentasjon på Norvax Compact 6. Product information materials for fish health personnel (confidential).
50. Reitan LJ (1999). Project FAIR-CT95-0353 Recombinant vaccines against infectious pancreatic necrosis (IPN) in salmonid fish. Final report from partner 4, National Veterinary Institute, Oslo. 21 p (confidential).
51. Rimstad E (2003). Protection of Atlantic salmon (*Salmo salar*) against IPN after DNA-vaccination. Presentation at the Fish Vaccinology Sattelite workshop on DNA vaccination. Bergen, 8.4.2003 (confidential)
52. ScanVacc AS (Jon Inge Erdal 2003) Presentation materials on Lipogen Pentium and Pentium Forte for fish health personnel (confidential)

## 7. Functional feed

- Certain functional feed seems to reduce mortality from IPN in salmonids under experimental conditions.
- Functional feed as we know them today do not solve the IPN problem in salmonid fish farming
- Good field trials with functional feed are missing.
- There is almost no published research on the effect of feed additives on IPN.
- Available data from field use of commercial functional feed against IPN seem unsatisfactory.
- Basic research on fish nutrition seems necessary.



Preventive effect against IPN from using feed with optimised nutritional properties or from functional feed represents a simple and available action towards the disease. Feeding strategy is a factor the fish farmer is in good control of - in contrary to other factors with consequence for occurrence of IPN.

### 7.1. Therapeutic treatment

Therapeutic diets are not known against viral diseases in fish. No therapeutic feed is available on the market. Damsgard, Mortensen and Sommer (1998) showed that feed intake and growth were significantly lower in fish experimentally infected with IPNV than in uninfected control groups. Some fish completely lost appetite. Still, IPNV-infected fish could have high virus titres before this effect was detectable, hence a therapeutic feed additive could theoretically be used against IPN. Siwicki et al (1998) showed increased immunologic parameters and reduced cumulative mortality from IPN in naturally infected rainbow trout that were fed with dimerized lysozyme (KLP-602). The mode of action for this feed additive is non-specific. Although the effect on cumulative mortality seems significant there was still high mortality in treated fish groups (30% versus 65%). There is no discussion about the "pen effect" in this study and no statistical analysis of the cumulative mortality rates.

### 7.2. Preventive treatments by functional feed

Functional feeds include immunostimulants and nutritional factors with effect on different parts of the immune system like stimulation of killer cells, complement or antibody responses or by facilitating the function of phagocytic cells. Sakai (1999) has written a review of fish immunostimulants, including both synthetic chemicals and biological substances. The review shows effects from different immunostimulants including more than 20 listed substances. None of them have documented effect towards IPN. Most results are on non-specific effects as increased phagocytosis, and many compounds give documented effect against bacterial pathogens. The only viruses referred to in this review are the Yellow-head baculovirus in Black Tiger shrimp and the IHNV in rainbow trout and

salmon. Shrimp seem to be more resistant to this virus when fed a diet including peptidoglycan. Large doses of vitamin C have increased resistance against IHNV in trout and low levels of vitamin E have been found in fish with acute IPN infection (Taksdal et al. 1995).

Both glucans and nucleotides have documented immunostimulating effect on salmonids. Several types of glucan have been tested (Engstad et al 1992, Jørgensen et al 1993). The effect can be dependent on route of administration and dose. Intraperitoneal administration is often superior to oral treatment. Glucan can show enhancing effect to other immune stimulating substances without showing any effect when administered alone (Sakai 1999).

Nucleotides have shown effect against bacterial, viral, rickettsial and ectoparasitic infections (Burrell, Williams and Forno, 2001). The results are based on oral distribution and show significant reduction for a period of time during the outbreak ( $p < 0.05$ ) on cumulative mortality after ISAV challenge, when compared to non-nucleotide diets. Specific effect against IPN has not been tested in the above-mentioned research.

### 7.3. Experiments with IPN

Johnsen (2001) shows results from an experimental study done by Fiskeriforskning, Tromsø. The study compares three diets in relation to cumulative mortality from a challenge test for IPNV (glucan/nucleotides, only nucleotides and control). Three groups were given different feed prior to exposure to seawater. After sea transfer they were kept together as cohabitants in three tanks and exposed to IPNV after one week. The study shows a RPS of 32% between fish given feed with 1,3/1,6-glucan and nucleotides compared to fish given just nucleotides (the RPS towards the control is not given, but the control group had slightly less cumulative mortality than the nucleotide-group).

EWOS (2000) shows results from a similar trial at Fiskeriforskning. This includes two control diets compared to their own commercial functional feed (which includes nucleotides, vitamins C and E and essential amino acids) by level of cumulative mortality from a challenge test with IPNV. The results show an RPS between the nucleotide-group and the control diets of 22% ( $p < 0.05$ ).

Leonardi et al (2003) have shown effect from nucleotide-enriched feed on resistance to IPN in rainbow trout. They challenged 8 fish fed a control diet and 8 fish fed nucleotide diet with IPNV through intraperitoneal injections of virus. All fish in the control group died versus none nucleotide group. IPN was diagnosed in the dead fish and clinical signs of IPN were present in both groups. The number of fish was small in this trial and statistic evaluation is not given, but the distinct difference in outcome strengthens the trial and results seem to indicate some protection from nucleotide diet on resistance towards IPN in rainbow trout.

...both glucans and nucleotides have documented immunostimulating effect in salmonids...

### 7.4. Field trials

Most feed companies presents field data with cumulative mortality from IPN in groups fed their own diet compared to other types of feed, both functional and ordinary. They show cases were groups fed their own feed experience less or similar mortality from IPN compared to groups fed other types of feed. The results are used in marketing and are not published. The design of these field trials often seems to be adapted to avoid conflict with

commercial interests of the fish farm involved. This will in many cases give an undesired uncertainty of the results, usually as a result of compromises to a good trial design – such as lack of replicates, use of different fish and different vaccines, unequal freshwater environment, unequal time of sea transfer and different sea environment. It is a paradox that good field trials have not been performed, considering that the IPN-problem is one of the biggest health problems in the aquaculture industry.

### 7.5. Is malnutrition a risk factor for IPN?

In general, malnutrition increases the risk of disease. Modern fish farming is still in search of basic knowledge about fish nutrition. Incidents of marginal nutritional deficiencies may therefore occur because of sub optimal feed. The fact that fish farming means feeding populations contributes to this situation through unavoidable underfeeding of individuals. Jarp (1998) reports of a tendency of lower feeding rate in fish farms with IPN versus non-IPN farms and that the type of feed being used was associated with the risk of getting IPN. However, temporary sub optimal feeding must be regarded as a normal setting for the industry and should never cause or trigger disease in the extent we experience IPN. Although few would disagree with the importance of correct and sufficient nutrition to fish health, the hypothesis that IPN-outbreaks are caused by malnutrition from imperfect commercial salmonids feed in general seems unpublished and unspoken. In a survey done by VESO (2003) among Norwegian fish farmers and fish health services, none mentioned malnutrition from imperfect commercial diets as a suspected cause for IPN outbreak when asked to address important causative factors based on own experience.



AKVAFORSK has raised the hypothesis that insufficient energy in fish feed can be a causative factor for IPN. They have started research on effect against IPN and PD from high-energy feeds. Pilot studies indicate that high fat content in feed reduces mortality from IPN (Rørvik pers.comm.). There is no published data on this subject yet.

## 7.6. References

1. Damsgaard B, Mortensen A and Sommer A.-I: Effects of infectious pancreatic necrosis virus (IPNV) on appetite and growth in Atlantic salmon, *Salmo salar* L 1998 Aquaculture Vol.163 Issues 3-4, p 185-193
2. Sakai M: Current research status on fish immunostimulants 1999, Aquaculture 172 p 63-92
3. EWOS Boost – brochure, IPN in controlled experimental trial at Fiskeriforskning
4. Johnsen M: "Kampen mot IPN" Norwegian Fish Farming, Vol 17 Nov 2002 p 42-44
5. Siwicki AK, Morand M, Klein P, Kicka W: Treatment of infectious pancreatic necrosis virus (IPNV) disease using dimerized lysozyme (KLP-602) 1998, Journal of applied ichthyology 14(3-4): 229-232
6. Engstad R E, Robertsen B, Frivold E: Yeast glucan induces increase in activity of lysozyme and complement-mediated haemolytic activity in Atlantic salmon blood. Fish Shellfish immunology 1992-2, 287-297
7. Joergensen JB, Sharp GJE, Secombes CJ, Robertsen B: Effect of yeast-cell-wall glucan on the bactericidal activity of rainbow trout macrophages, Fish Shellfish Immunology 1993-3, 51-58
8. Burrels C, Williams P D, Forno P F: Dietary nucleotides; a novel supplement in fish feeds 1: Effects on resistance to fish disease in salmonids 2001, Aquaculture 199 p 159-169
9. Taksdal T, Poppe T, Sivertsen T, Ferguson HW. Low levels of vitamin-E in plasma from Atlantic salmon *Salmo salar* L with acute infectious pancreatic necrosis (IPN) 1995, Diseases of aquatic organisms 22 (1): 33-37
10. Roervik: "Effect of increased available energy on IPN and PD in sea farmed salmonids" project application The Research Council of Norway 2002
11. Leonardi M, Sandino AM, Klempau A Effect of a nucleotide-enriched diet on the immune system, plasma cortisol levels and resistance to infectious pancreatic necrosis (IPN) in juvenile rainbow trout (*Oncorhynchus mykiss*) Bulletin of EAFP 23(2) 2003, 52-59
12. VESO Survey about IPN-experiences in Norwegian aquaculture , preliminary results) 2003
13. Dahl. Product manager – Skretting "Respons® reduces mortality from IPN" Skrettings information magazine "På Merdkanten" Nr 2 2002
14. Information from the feed industry: brochures, lectures, hand-outs – from Skretting, Biomar and EWOS
15. Waagboe R National Institute of Nutrition and Seafood Research (NIFES) Pers.com.



## 8. Current research on IPN

The purpose of this report is to provide an overview on current research project on IPN within the international scientific community.

In Norway, a comparably huge amount of money has been spent on *IPN*- and *IPNV*-related research over the last 5-6 years, and numerous and voluminous projects are still on going. To which degree these investments are paying off in terms of science achievements and economic returns for society needs to be evaluated, and an analysis of these aspects seems timely. It may be suggested that focus should now be to increase the efficacy of future investments in IPN research, giving priority to problem-solving projects and projects offering real promise for improvement in disease control in short- and medium term. The identification of the most important bottlenecks in science and technology, currently hindering the progress in the control of IPN is therefore needed.



### 8.1. Norwegian research projects

Between 1996 and 2002, 19 research projects dealing explicitly with IPN or with major relevance for IPN research were launched, with another 4 projects being initiated during 2003 (table 1). The financial support for these projects coming from government research programmes and the FHF totals approx. 30 million NOK. In addition, 21 (mainly basic science) projects have been identified having partial or potential relevance for IPN research, enjoying a total financial support of nearly 90 million NOK. It is therefore evident that there has been and still is a remarkable investment into IPN research by Norwegian government and industry funding bodies. To which degree these investments have really contributed to problem solving and given reasonable economic and knowledge returns for society may be questioned, in particular taking into account the continuing endemic spread and high disease losses.

### 8.2. EU funded research projects

In the EU, the interest for and investment into IPN research has been far less than in Norway, and only one EU funded project (1996-1999) has specifically addressed this disease. A number of projects of partial and potential relevance for IPN research have, however, been found making a total of 8 projects with a grant volume of nearly 6 mill. Euro (Table 3).

### 8.3. IPN research projects in the UK

As compared to Norway, IPN-specific research projects in the UK have been relative scarce during latter part of the 1990ies. This situation has now apparently changed, as at least 8 in part quite large projects with major relevance for IPN have been launched during the last 1-2 years (Table 4). The majority of these efforts are applied research projects, targeted at generating information or methods needed to improve disease control measures in Scottish salmon farming. The total investment into IPN research for the current period (2000-2007) mainly by Scottish authorities and funding bodies is estimated above 27 mill. NOK. As the information about various funding sources may be incomplete, this must be regarded a low-end estimate.

## 8.4. Tabular overview

### 8.4.1. Norway: NFR/FHF projects with major relevance and focus on IPN

Grant source	Reference no	Title	Responsible scientist	Institution	Start date	End date	Grant (1000 NOK)
NFR/Havbruk	152967/120	Study of early cellular responses to IPN virus infection in salmonids	Evensen, Øystein	Norges veterinærhøgskole	01.07.2003	30.06.2006	2400
NFR/Havbruk	152045/120	Effekt av samspill mellom økt energitilgang og vaksinerings på Rørvik, Kjell Arne IPN og PD hos laks i sjø		AKVAFORSK - Ås	01.01.2003	31.12.2005	1800
NFR/Havbruk	152989/120	The effect of virus infection on expression of interferon-induced proteins in Atlantic salmon	Robertsen, Børre	Norges Fiskerihøgskole	01.01.2003	31.12.2005	2000
FHF	155157	Vannkvalitet og risiko for IPN hos laksesmolt	Hilde Toften	Fiskeriforskning AS	2003	2005	1300
FHF	150783	Overføring av IPN-virus fra stamfisk til avkom	Taksdal, Torunn	Veterinærinstituttet Oslo	2002	2003	624
FHF	152051	Infeksjons pankreas nekrose (IPNV) infeksjon - en immunologisk utfordring for intensiv smoltproduksjon	Wergeland, Heidrun	IFM, Univ. I Bergen	2002	2004	1775
FHF	152043	Studies of factors related to susceptibility or resistance in IPN virus infection .... throughout the production cycle	Evensen, Øystein	Norges veterinærhøgskole	2002	2004	1900
NFR/Havbruk	146790/120	Studies of basic mechanisms of cell virus interaction related to expression of individual virus protein of IPN virus in transfected cell lin	Evensen, Øystein	Norges veterinærhøgskole	1.11.2001	31.12.2004	1900
NFR/Havbruk	141887/120	Studier av virulensfaktorer hos norske feltsolater av IPN virus	Sommer, Ann-Inger	Fiskeriforskning AS	1.1.2001	31.12.2003	2460
FHF	149527	Sub-optimalt vannmiljø i ferskvannsfasen: Effekter på smoltkvalitet, helse og risiko for IPN hos laks	Toften, Hilde	Fiskeriforskning AS	2001	2002	500
FHF	150781	Validering og standardisering av badsmitte- modell med IPNV for å teste effekt av kommersielle IPN-vaksiner.	Ramstad, Anne	Veterinærmedisinsk oppdragscenter AS	2001	2002	500
NFR/Havbruk	141666/120	Betydningen av stress hos laksesmolt under og etter brønnbåttransporter	Bengt Finstad	NINA-NIKU	2001	2002	590
NFR/Havbruk	134136/120	Studies of mechanisms related to virulence and persistence of IPN virus infection in Atlantic salmon	Evensen, Øystein	Veterinærinstituttet Oslo	1.7.2000	30.6.2003	1523
NFR/Havbruk	134168/120	Antivirale gener i interferon-systemet hos laksefisk. (Interferon inducible antiviral genes of salmonids)	Robertsen, Børre	Norges Fiskerihøgskole	1.7.2000	1.7.2003	1656
NFR/Havbruk	137477/120	Genetisk resistens mot infeksjons pankreasnekrose (IPN) hos atlantisk laks	Storset, Arne	Aqua Gen AS	1.1.2000	1.7.2002	1470
NFR/Havbruk	133038/120	Kartlegging av horisontal smitte fra kar til kar via avløp i settefiskanlegg med IPN-problem	Bård Skjelstad	Veterinærmedisinsk oppdragscenter AS	1.1.2000	31.12.2000	80
NFR/Havbruk	133042/120	Internsvit fiskeoppdrett og utbrudd av IPN	Sommer Ann-Inger	Fiskeriforskning Tromsø	1999	2000	850

NFR/Havbruk	133039/120	Smitte av smolt produsert under industribehandling	Brit Hjeltnes	Havforskningsinstituttet	1999	2000	500
NFR/Havbruk	133041/120	Videreutvikling av smittemodell for IPN hos laks	Torunn Taksdal	Veterinærinstituttet	1999	2000	350
NFR/fiske-og dyrehelse	120043/122	Utvikling av DNA-vaksine mot IPN virus hos atlantisk laks i oppdrett (brugerstyrt)	Anne-Lill Hellemann	Genomar AS	1998	1999	500
NFR/fiske-og dyrehelse	110555/122	IPN virus: replikasjon, patologi og mulig effekt på immunsystemet (Dr. gradsstipend)	Endresen Curt	Universitetet i Bergen	1997	1999	1200
NFR/fiske-og dyrehelse	110553/122	Bæretilstand av IPN-virus i atlantisk laks og virkning på immunforsvar og helse	Sommer Ann-Inger	Fiskeriforskning	1996	1998	1500
NFR/fiske-og dyrehelse	110561/122	Epidemiologiske studier av IPN hos laks	Jarp Jorun	Veterinærinstituttet	1996	1998	1500
SUM							29878

#### 8.4.2. NFR/FHF projects with partial or potential relevance for IPN research

Grant source	Reference no	Title	Responsible scientist	Institution	Start date	End date	Grant (1000 NOK)
NFR/Havbruk	153062/120	Immunological and cellular responses to viral infections in Atlantic halibut	Sindre, Hilde	Veterinærinstituttet Oslo	01.01.2003	31.12.2003	250
NFR/Havbruk	153202/120	Vannkvalitet, vannbehandling og intensiv smoltproduksjon. Effekter av ulike råvann/driftsvann kvaliteter og superoksygenering på smoltkvalitet	Rosseland, Bjørn Olav	Norsk institutt for vannforskning	01.01.2003	31.12.2005	3600
NFR/Havbruk	146852/120	Studier av tre laksepatogene virus (Utenlandsopphold)	Endresen, Curt	Universitetet i Bergen	1.1.2002	31.12.2002	245
NFR/Havbruk	146858/120	The impact of smoltification on salmon immune response	Wergeland, Heidrun	Universitetet i Bergen	1.1.2002	31.12.2004	1980
NFR/Havbruk	146639/120	Bruk av ozon og UV-bestråling for kontroll av virus i marint oppdrett	Liltved, Heige Forsker	Norsk institutt for vannforskning	1.1.2002	31.12.2003	570
FHF	152029	Can mussel act as vectors of fish pathogenic bacteria and virus?	Mortensen, Stein	Havforskningsinstituttet	2002	2003	4000
FHF	152052	Overføring av patogene fiskevirus mellom marine oppdrettsarter	Dannevig, Birgit	Veterinærinstituttet	2002	2003	2000
NFR/Havbruk	146391/120	The use of marine biotechnology to control and prevent viral disease in high value, farmed fin fish - development of efficacious vaccines	Evensen, Øystein	Alpharma AS	1.6.2001	1.6.2002	100
NFR/bioteknologi 2000	146163/130	Bruk av MHC-gener i markørassistert seleksjon for øket sykdomsresistens hos laks	Landsverk Kristina	AquaGen AS	2001	2004	1851
NFR/FUGE	151938/150	Expression and function of disease related genes in Atlantic salmon	Unni Grimholt	Norges veterinærhøgskole	2002	2007	35821

NFR/SIP-SUP	143286/140	Virological investigations on emerging disease conditions in domestic animals and fish	Dannevig, Birgit	Veterinærinstituttet	2001	2005	4300
NFR/bioteknologi 2000	138776/130	Bruk av laksepromotorer i ekspressionsvektorer i forskjellige organismer	Anne-Lill Hellemann	Genomar AS	2000	2002	1260
NFR/bioteknologi 2000	133745/130	CpG-oligoer – en ny klasse adjuvans i vaksiner mot virussykdommer hos laks	Jørgensen Jorun B.	Fiskeriforskning	2000	2002	2400
NFR/fiske-og dyreheise	123787/120	Reservoarer og persistens for fiskepatogene virus	Enger Øyvind	Universitetet i Bergen	1998	2000	1347
NFR/SIP-SUP	124043/140	Flekksteinbit - Immunforsvar og mottakelighet for smittsomme sykdommer	Espelid Sigrun	Fiskeriforskning	1998	2002	8700
NFR/SIP-SUP	124210/140	Sjukdommer hos marin oppdrettsfisk	Håstein, Tore	Veterinærinstituttet	1998	2002	7420
NFR/fiske-og dyreheise	115939	Påvisning av fiskepatogene virus i oppdrettsmiljø ved hjelp av kvantitativ PCR-teknikk II	Enger Øyvind	Universitetet i Bergen	1997	1997	450
NFR/bioteknologi 2000	113902/130	Antivirale MX-gener hos laks	Robertsen Børre	Norges Fiskerihøgskole/ Universitetet i Tromsø	1997	2000	1125
NFR/SIP-SUP	111257/130	Immunologiske mekanismer ved virale og bakterielle infeksjoner hos marin fisk	Jørgensen Trond Ø	Norges Fiskerihøgskole/ Universitetet i Tromsø	1996	2000	7200
NFR/fiske-og dyreheise	110606/122	Immunprofylaktiske metoder og strategier tilpasset kveiteproduksjon i Norge (brugerstyrt)	Odd Magne Rødseth	Intervet Norbio AS	1996	1998	1336
NFR/fiske-og dyreheise	107137/122	Smoltifisering og sykdomsutvikling	Eggset Guri	Fiskeriforskning	1995	1996	1200
SUM							88155

#### 8.4.3. EU research and development projects with relevance for IPN research

Grant source	Reference no	Title	Responsible scientist	Institution	Start date	End date	Grant (EURO)
LIFE QUALITY	QLRI-CT-2002-2819	Development of a European resource on the origins of pathogens of aquaculture	Secombes Chris	University of Aberdeen	2003	2003	249646
LIFE QUALITY	QLK2-CT-1546	Appraisal of the zoo-sanitary risks associated with trade and transfer of fish eggs and sperm	Midtlyng, Paul J	VESO	1.9.2002	31.8.2005	300000
LIFE QUALITY	QLK2-CT-2002-0838	Development of a pathogen epitope prediction program, and evaluation of its usefulness in designing fish vaccines	Gjøen, Tor	University of Oslo	2002	2005	1600000
LIFE QUALITY	QLK5-CT-2001-51038	Genetic factors influencing disease susceptibility in cultured fish	Stevenson-Robb, F.	University of Aberdeen	2002	2004	114472
LIFE QUALITY	QLK2-CT-1691	Anti-viral innate immunity in cultured aquatic species	Renault, Tristan	IFREMER Nantes	2002	2005	1250000

LIFE QUALITY	QLK2-CT-2000-1076 98-4064	Stimulation of fish larval defence mechanisms against infectious diseases	Dalmo, Roy A	Norges Fiskerihøgskole/ Universitetet i Tromsø	2001	2004	1240000
FAIR	95-0353	Diagnostic methods and reference panel of reagents for detection and typing of fish viruses	Björklund, Harry	Åbo Akademi	1999	2001	540000
FAIR		Recombinant IPN vaccines against infectious pancreatic necrosis	Vaughan Larry	BioResearch Ireland	1996	1999	619872
SUM							5913990

#### 8.4.4. UK projects and grants in support of IPN research

Grant source	Reference no	Title	Responsible scientist	Institution	Start date	End date	Grant (1000 NOK)
Unknown	unknown	Real-time PCR for IPNV (Ph.D. grant G. McKinley)	W. Starkey	Institute for Aquaculture, Stirling	2003	no info	no info
Univ. Stirling	unknown	Characterisation of genomic variation in IPN virus	W. Starkey	Institute for Aquaculture, Stirling	2003	no info	0
CROWN ESTATE	unknown	IPN case control studies	no info	FRS Marine Lab	no info	no info	no info
SEERAD*/FRS	unknown	IPN testing and transmission	Ellis Tony Smail David	FRS Marine Lab	2003	2007	(3170/yr) 15850
FRS*	unknown	Joint industry-FRS subgroup on IPN	Cunningham Carey Hastings Trevor	FRS Marine Lab	2002(?)	May 2003	No info
SEERAD/FRS	unknown	IPN epidemiology	Raynard Rob	FRS Marine Lab	2002	2005	(1400/yr) 4200
CROWN ESTATE	unknown	Development of a novel treatment against IPN	Ellis Tony	FRS Marine Lab	2002	no info	225
SEERAD/FRS	unknown	Pathogenic IPN	Ellis Tony Smail David	FRS Marine Lab	2000	2003	(1620/yr) 6480
CEFAS‡	unknown	Serogrouping of aquatic bimaviruses	Dixon Peter	CEFAS Weymouth	ongoing	ongoing	0
SUM							>27000

\*Scottish Executive Environment and Rural Affairs Department;

#Fisheries Research Services; ‡Centre for Environmental,

‡Fisheries and Aquaculture Science



### 8.5. Current IPN research in the rest of Europe

In Denmark, the National Veterinary Institute laboratory in Aarhus (which is also the European Union reference laboratory for fish viral diseases) is working on a project on the feasibility of sero-surveillance for testing rainbow trout broodstock for IPNV exposure (Ariel 2003, pers. comm). In collaboration with the FRS Marine laboratory in Aberdeen (Trevor Hastings), the Aarhus laboratory also currently evaluates the sensitivity of different methods for isolation of IPNV from rainbow trout and Atlantic salmon (Ariel 2003, pers. comm.). Since completion of a EU project on vaccine development (see FAIR 95-0353 above), there has been no IPN research project in Ireland (Todd 2003, pers. comm.). No IPNV research projects are currently being conducted in Finland (Koski 2003, pers. comm.) neither is any information about IPN-specific projects available from Sweden or Iceland. In Italy there is currently no research activity on IPN, obviously because the epizootic situation has improved a lot since the mid-1980ies, when IPN epizootics were frequent in Italian trout culture (Bovo 2003, pers. comm.). There is very little activity on IPN research in the Balkans, but Slovenian authors have recently published work comparing virus isolation and molecular methods for routine IPNV diagnosis (Barlic-Maganja et al. 2002).

In Germany, IPNV is occasionally found during routine monitoring and surveillance in rainbow trout farms. The number of positive farms have remained very steady (between 55 and 68) since 1999 (D. Fichtner, pers. comm). One specific research project (2000-2003) dealing with the establishment and application of a reverse genetics system for IPNV is currently being carried out, some results from which have been published (Weber et al. 2001). The heat stability of pathogenic fish microorganisms, amongst these also IPNV, have been investigated by Rapp et al. (2000).

The IPN-related research in France was for many years headed by Dr. Michel Dorson at INRA Juoy-en-Josas, who amongst other subjects published experimental evidence for vertical transmission of IPNV via rainbow trout sperm (Dorson et al. 1997). Apparently, this group's IPN projects have now come to an end. There is, however, research activity on the molecular biology of IPNV and other fish viruses, this work being headed by Dr. Bernard Delmas (Elouet et al. 2001). In the ASSFA fish disease laboratory in Brest, there has been no IPN research activity for many years (Claire Quentel, pers. comm.).



In Spain, (Lopez-Lastra et al 1994) developed an RT-PCR diagnostic method for IPNV and work to further improve the application of this method is currently being conducted in Santiago de Compostela (Oliveira et al. 2003). This group is also involved in the characterisation of IPNV isolated from Spain (Cutrin et al. 2000).

From Portugal, Russia, the Netherlands and Belgium, there is no information about specific IPN or IPNV research projects.

### 8.6. Current IPN research in North America

The Eastern Fish Health Laboratory in Leetown, West Virginia has been the historical stronghold of IPN research in North America, in particular associated with the emergence of fish virology as a science and the work of Dr. Ken Wolf. After Dr. Wolf's retirement, the IPN work has been carried forward by Dr. Phillip E. McAllister who is the senior virologist and IPN researcher in this laboratory today and who is continuing to actively publish IPN research

results (Bebak et al. 2002, McAllister et al. 2000, Smith et al. 2000). Due to re-organisation of the laboratory and funding constraints, IPN research obviously enjoys significantly less priority than earlier years.

Research in particular relating to the development and validation of molecular genetics and molecular diagnosis of IPNV and other fish viruses (PCR and multiplex PCR) is being carried out by Professor Bruce Nicholson's group at the University of Maine, Orono (Blake et al. 2001, Williams et al. 1999).

The research group of Dr. Vikram Vakharia from the University of Maryland Biotechnology Institute, College Park, is carrying out research on the development of recombinant IPNV antigen. The prospects of a recombinant subunit vaccine against IPNV produced in a baculovirus/insect larvae system has recently been reported (Vakharia 2003). The work was based upon industrial and USDA funding (Vakharia 2003, pers. comm.) This group has also developed a reverse genetics system for IPNV allowing for functional research on virulence determinants, and the production of defective viral particles potentially allowing the development of live attenuated IPN vaccine (Yao and Vakharia 1998, Evensen et al. 2002).

The fourth science group with a considerable track record of IPN research is Dr Paul Reno, who is currently employed at Hatfield Marine Science Centre at Oregon State University, Corvallis. The low publications activity (papers and conference presentations) relating to IPN confirms, however, that the funding of IPN research in the USA is currently very low (Reno 1999, Bruslind and Reno 2000).

IPN research was not mentioned among current fish health research in British Columbia (Simon Jones, BC Aqua Forum Jan 25, 2002) and there were no contributions relating to IPNV neither at the Western Fish Health Conference 2001 nor at the Eastern Fish Health Conference in 2003 (Midtlyng, personal observation).

### **8.7. Current IPN research in Chile and other parts of South America**

In Chilean salmonid aquaculture, outbreaks of clinical IPN are well known both in hatcheries and in post-smolts, much resembling the situation in Norway and Scotland. Both North American and European variants of IPNV have been found in Chile, and work to characterise isolates from clinical outbreaks is being conducted by at least one of the Chilean veterinary fish health services (Scott La Patra, pers. comm.). Further scientific projects relevant to IPN relate to experimental trials to assess the pathogenicity of Chilean IPNV isolates (Rivera et al. 2003) and work to optimise a method for concentration and detection of IPNV in fresh water samples (J. Larenas, pers. comm).

After its first isolation in 2000 (Ortega et al. 2002) a regional epidemiological study of IPNV in freshwater rainbow trout farms has been reported from Mexico, showing a 83% prevalence of virus positive farms but only 1 clinical case (Ortega and Vega 2003).

### **8.8. Current IPN research in Asia and Australia**

Japanese researchers have shown a significant involvement in IPN research. In recent years, Professor Okamoto at the Tokyo University of Fisheries have pursued research on the molecular genetics of heritable resistance to IPN, identification of quantitative traits loci (QTL) and evaluation of marker-assisted selection of rainbow trout for IPNV resistance (Midtlyng et al. 2001, Ozaki et al. 2001). Further activity in Japan apparently relates to

investigations on the susceptibility of aquatic birnaviruses to marine fish species (Ishiki et al. 2002), and to IPNV surveillance in returning wild salmon stocks (Yoshimizu et al. 2003).

In Taiwan, IPNV research has been, and still is, focused around the molecular biology of IPNV, in particular the induction of apoptosis (Hong and Wu 2002, Hong et al. 2002). The molecular aspects of IPNV have also been the focus of Korean workers (Park and Jeong 1996).

No information about IPN-specific projects has been found from Australia or other parts of Oceania.

### 8.9. Scrutiny of further research databases and sources of information

No projects under evaluation per March 2003 with the Norwegian Research Council's programme for aquaculture were related to IPN, neither are any of the projects currently funded by NRC's programme for feral salmon ("villaksprogrammet").

### 8.10. Industrial research and development projects of relevance

#### 8.10.1. Intervet Norbio AS

This company has developed a new series of injectable vaccines for salmon (Norvax Compact), including purification and concentration of recombinant IPNV antigen (rVP2) produced in *E. coli*. The vaccine series was launched 1999. On-going work is related to development of a 3<sup>rd</sup> generation IPN-rVP2 injectable vaccine, and research on the prospects of developing an immersion IPN vaccine for fry. Intervet Norbio is also partner and co-sponsor of a project to identify predisposing factors and determinants for IPN outbreaks in commercial scale salmon farming (Rødseth 2003, pers. comm).



#### 8.10.2. Alpharma AS

A new injectable product series with inactivated cell-culture grown IPNV serotype Sp antigen (Alpha Ject 6-2) was recently developed and launched commercially in November 2002. Field evaluation trials of this vaccine are still on going. Alpharma has also developed a monovalent, injectable IPN vaccine based upon the same antigen concept (Alpha Ject 1000) for the Chilean market, which was launched in 2002. A bivalent IPN vaccine formulation for the Chilean market (Alpha Ject 2200) is currently under field evaluation (Aas-Eng 2003, pers.comm).

#### 8.10.3. Aqua Health Ltd./ScanVacc AS

A new injectable product series prepared with inactivated cell culture grown IPNV antigen (Pentium Forte) was commercially launched in Norway in 2002 and results showing vaccine protection against field challenge has been presented (Erdal et al. 2003). Aqua Health Canada is currently involved in the development of experimental IPNV challenge models for Atlantic salmon. In Norway, ScanVacc is a co-sponsor of a research project pertaining to the importance of vertical transmission for IPN outbreaks in start feeding fry, and how the risk for vertical transmission can be controlled through vaccination or treatment of the broodfish (Erdal 2003, pers.comm.).

#### 8.10.4. Schering-Plough AH

SPAH has recently developed a bivalent injectable vaccine including IPNV antigen for salmon, which is currently available for use in Scotland. A monovalent variant of this IPNV vaccine has been developed for the Chilean market. SPAH are further exploring the prospects

of a concept for oral booster vaccination against IPNV using their patented “antigen protection vehicle” (APV) technology (Ness 2003, pers.comm.).

#### 8.10.5. Microtek International Inc.

This British Columbia Company has announced the development of a recombinant IPNV vaccine based upon a new expression system in *E. coli*, which is being tested in experimental and field trials in Chile (anonymus, undated).

Biotec AHN (Animal Health and Nutrition) has recently finished an evaluation of  $\beta$ -1,6/1,3 glucan as an immunostimulant for use to support vaccine protection against experimental IPN challenge (Johnsen 2002).

The Norwegian biotechnology company Genomar AS has announced the successful evaluation of a DNA vaccine against IPNV in an experimental challenge trial (Hellemann 2002) and scientific publication of these results are being awaited (Rimstad 2003, pers. comm.).

As evident from the tables above are development projects to further standardise and sophisticate experimental challenge models for IPN on-going both in Kårvika, at VESO Vikan AkvaVet (Ramstad 2003, Ramstad and Midtlyng 2003) and in the Marine Laboratory Aberdeen (Bowden et al. 2002).

## 8.11. References

1. Barlic-Maganja D, Strancar M, Hostnik P, Jencic, V and Grom, J (2002). Comparison of the efficiency and sensitivity of virus isolation and molecular methods for routine diagnosis of infectious haematopoietic necrosis virus and infectious pancreatic necrosis virus. *Journal of Fish Diseases*, 2002. 25(2): p. 73-80.
2. Bebak J, McAllister PE and Boston R 2002. Effect of fish density and number of infectious fish on the survival of rainbow trout fry, *Oncorhynchus mykiss* (Walbaum), during epidemics of infectious pancreatic necrosis. *J. Fish Dis.* 25: 715-726.
3. Blake S, Ma J-Y, Caporale DA, Jairath S Nicholson BL (2001). Phylogenetic relationships of aquatic birnaviruses based on deduced amino acid sequences of genome segment A cDNA. *Dis. Aquat. Organ.* 45:89-102.
4. Bowden TJ, Smail DA, and Ellis AE (2002). Development of a reproducible infectious pancreatic necrosis virus challenge model for Atlantic salmon, *Salmo salar* L. *J. Fish Dis.* 25:555-563.
5. Bruslind LD and Reno PW (2000). Virulence comparison of three Buhl-subtype isolates of infectious pancreatic necrosis virus in brook trout fry. *J. Aquatic Animal Health* 12:301-315.
6. Cutrin JM, Oliveira JG, Barja JL. & Dopazo CP (2000). Diversity of infectious pancreatic necrosis virus strains isolated from fish, shellfish, and other reservoirs in northwestern Spain. *Appl Environ Microbiol* 66 (2): 839-843.
7. Dorson M, Rault P, Haffray P & Torhy C. (1997). Water-hardening rainbow trout eggs in the presence of an iodophor fails to prevent the experimental egg transmission of infectious pancreatic necrosis virus. *Bull Eur Ass Fish Pathol* 17(1): 13-16.
8. Eleouet JF, Druesne N, Chilmonczyk S, Monge D, Dorson M, Delmas B (2001). Comparative study of in-situ cell death induced by the viruses of viral haemorrhagic septicaemia (VHS) and infectious pancreatic necrosis (IPN) in rainbow trout. *J Comp Pathol* 124:4 300-7
9. Erdal JI, Skjelstad B and Soleim KB (2003). Evaluation of protection from vaccination against infectious pancreatic necrosis (IPN) in a GCP field trial in Norway. Book of abstracts, 11<sup>th</sup> Conference of the EAAP, Malta 21-25 Sept 2003, O-103.
10. Evensen Ø, Vakharia V, Yao K, Aas-Eng A (2002). Attenuated infectious pancreatic necrosis virus produced from cloned DNA will not induce pathological changes in fry of Atlantic salmon. Book of abstracts, 4<sup>th</sup> symposium on diseases in Asian aquaculture, Nov 22-26, Cebu, Philippines (unpaged).
11. Hong JR and Wu JL (2002). Induction of apoptotic death in cells via Bad gene expression by infectious pancreatic necrosis virus infection. *Cell Death Different.* 9, 113-124.
12. Hong JR, Gong Hy and Wu JL (2002). IPNV VP5, a novel anti-apoptosis gene of the Bcl-2 family, regulates Mcl-1 and viral protein expression. *Virology* 295, 217-229.
13. Labus MB, Breeman S, Ellis AE, Smail DA, Kervick M and Melvin WT (2001). Antigenic comparison of a truncated form of infectious pancreatic necrosis (IPN) virus expressed in four different cell types. *Fish & Shellfish Immunology* 11; 203-216.
14. Lopez-Lastra M, Gonzales M, Jashes M and Sandino AM (1994). A detection method for infectious pancreatic necrosis virus (IPNV) based on reverse transcription (RT)- polymerase chain reaction (PCR). *Journal of Fish Diseases* 17, 269-282.
15. McAllister, PE, Bebak J and Wagner BA, Susceptibility of Arctic Char to Experimental Challenge with Infectious Hematopoietic Necrosis Virus (IHNV) and Infectious Pancreatic Necrosis Virus (IPNV). *Journal of Aquatic Animal Health*, 2000. 12: p. 35-43.
16. Midtlyng PJ, Storset A, Michel C, Slierendrecht WJ and Okamoto N (2002). Breeding for disease resistance in fish. *Bulletin of the European Association of Fish Pathologists* 22 (2), 166-172
17. Oliveira JG, Cutrin JM, Lopez-Vasques C, Castro S, Romero-Brey I and Dopazo CP (2003). Assessment of the optimum fish tissue for diagnosis of IPN virus by RT-PCR. Book of abstracts 11<sup>th</sup> EAAP Conference Malta 21-25 Sept 2003, P-178
18. Ortega S, Montes de Oca R, Groman D, Yason C, Nicholson B and Blake S (2002). Case report: Viral infectious pancreatic necrosis in farmed rainbow trout from Mexico. *Journal of Aquatic Animal Health* 14 (4) 305-310.
19. Ortega C and Vega F (2003). Diagnostic study of viral infectious pancreatic necrosis in the trout culture areas in the state of Hidalgo, Mexico. Book of abstracts 11<sup>th</sup> EAAP Conference Malta 21-25 Sept 2003, P- 132.
20. Ozaki, A., Sakamoto, T., Khoo, S., Nakamura K., Coimbra M.R.M., Akutsu T and Okamoto N. 2001. Quantitative trait loci (QTLs) associated with resistance/susceptibility to infectious pancreatic necrosis virus (IPNV) in rainbow trout (*Oncorhynchus mykiss*). *Mol. Genet Genomics* 265, 23-31.
21. Park JW and Jeong GJ (1996). Identification of VP3 as an important neutralising epitope from DRT strain, a Korean isolate of infectious pancreatic necrosis. *Fish and Shellfish Immunology* 6, 207-219.



22. Ramstad A (2003). Consistency of an IPNV bath challenge model in normal and out-of season Atlantic salmon smolts). Book of abstracts, 3<sup>rd</sup> International IABS symposium on fish vaccinology, Bergen 9-11 April 2003, p. 93.
23. Ramstad and Midtlyng (2003): Further analysis of protection induced by IPNV vaccines tested in 4 vaccination-and-challenge trials. Book of abstracts 11<sup>th</sup> EAAP Conference Malta 21-25 Sept 2003, O-102
24. Rapp J, Krauth H, Mang C and Miller Th (2000). Untersuchungen zur Hitzestabilität verschiedener pathogener Mikroorganismen der Fische. Fishkrankheiten; VIII Tagung der Deutschen Sektion der EAAP,c 19-21 September 2000; p. 48-57.
25. Reno, P.W. 1999. Infectious Pancreatic Necrosis and Associated Aquatic Birnaviruses. In: Fish Diseases and Disorders. Vol. 3: Viral, Bacterial and Fungal Infections. Eds. P.T.K. Woo and D.W. Bruno. Pp.: 1-55. CABI Publishing, ISBN 0851991947.
26. Rivera A, Monras M and Enriquez R (2003). Pathogenicity of two Chilean IPN isolates and VR-299 strain of the virus in Atlantic salmon (*S. salar*) and rainbow trout (*O. mykiss*). Book of abstracts 11<sup>th</sup> EAAP Conference Malta 21-25 Sept 2003, P-14.
27. Shivappa RB, McAllister PA and Vakharia V (2002) A subunit vaccine for infectious pancreatic necrosis virus using a baculovirus/insect larvae system. Proceedings from the 4th International Symposium, on Aquatic Animal Health, New Orleans 1-5 Sept 2002, p. 178.
28. Shivappa RB, McAllister PE, Santi N, Evensen Ø and Vakharia V (2003) Development of a subunit vaccine for IPNV using a baculovirus insect/larvae system. Book of abstracts, 3<sup>rd</sup> International IABS symposium on fish vaccinology, Bergen 9-11 April 2003, p. 51 and oral presentation (ibid.)
29. Singer JT, Edgar JH and Nicholson BL (1998). Expression of capsid proteins from infectious pancreatic necrosis virus (IPNV) in the marine bacterium *Vibrio anguillarum*. Marine Sea Grant – New developments in Marine Biotechnology, vol 68, 303-306.
30. Smith G, Bebak J and McAllister PE (2000). Experimental infectious pancreatic necrosis infections: propagative or point-source epidemic? *Prev. Vet. Med.* 47: 221-241.
31. Williams K, Blake S, Sweeney A, Singer JT and Nicholson BL (1999). Multiplex reverse transcriptase PCR assay for simultaneous detection of three fish viruses. *Journal of Clinical Microbiology* 37 (12) 4139-4141.
32. Weber S, Fichtner D, Mettenleiter TC, Mundt E (2001). Expression of VP5 of infectious pancreatic necrosis virus strain VR299 is initiated at the second in-frame start codon. *J Gen Virol.* 82 (4): 805-12.
33. Yozhimishu M, Kasai Nishizawa T, Nomura T and Kimura T (2003). Surveillance and control of salmonid viruses of wild salmonid fish returning to the Northern part of Japan from 1976 to 2002. Book of abstracts 11<sup>th</sup> EAAP Conference Malta 21-25 Sept 2003, P-133.

### Commercial publications

Alpharma AS (anonymus Feb 2002). Alpharma Aquatic Products expand its activities in Chile. Press release 1p.

Aqua Health Europe Ltd. (anonymus, undated). Product News – Infectious Pancreatic Necrosis. URL: <http://www.aquahealth.co.uk/news.htm>.

Microtek International (anonymus, undated). Recombinant infectious pancreatic necrosis vaccine. URL: <http://www.microtek-intl.com/research/Temp/IPNV/>

Genomar AS (Anne-Lill Hellemann 04.11.2002). Fish Health. URL: [http://www.genomar.com/about\\_vaccines.asp](http://www.genomar.com/about_vaccines.asp)

Johnsen M (2002). Kampen mot IPN. I dybden vol 18, (2), 293-296.

## Annex 1

### Biosecurity issues to be addressed to reduce the risk from IPN

#### Cross contamination from equipment and people

- Risk assessment and disinfection the movements of people and equipment that have be in contact with farmed fish
- If nets from different farms are washed at a common location, care should be taken to avoid cross-contamination and transfer of infection between nets from different farms.
- Where possible, equipment should be site-specific. Where movements of equipment between sites is unavoidable, it must be thoroughly cleaned and disinfected.
- Staff should be trained in cleaning and disinfection routines.
- Staff and other relevant parties (e.g. fish transporters) should be kept informed on the health status of fish in their care.
- Farm operations should be managed to minimise the number of fish movements.
- Movements of vehicles, wellboats and equipment between farms should be kept to a minimum.
- Wellboats should operate with valves closed within a 5 km range of any fish farm.
- Divers should use site-specific gear where possible. If the movement of diving gear is unavoidable it should be thoroughly cleaned and disinfected between operations on different farms.
- Access to farms by visitors should be minimised where possible. When access is necessary, site-specific protective clothing and boots should be available for use by farm visitors.
- Where practicable farms should not share mortality ensiling points. Where farms cannot avoid sharing ensiling points, particular care should be taken to prevent transfer of pathogens between the farms.
- Equipment used to remove or transport dead fish should be disinfected after use.
- Divers should use site-specific gear or disinfect their equipment thoroughly between diving operations on different sites.

#### Harvesting and processing

- Disinfection of blood water and discharges to the environment from processing plants
- For on farm slaughter killing tables should be equipped with sides high enough to prevent escapes or have a net positioned to capture any escaped fish. A tarpaulin under the killing table will contain blood spillage. Whenever possible, harvesting operations should be carried out in good weather conditions.
- Wellboats transporting live fish to a processing plant should operate with closed valves when operating within a 5km range of any fish farm.
- Off-loading bays at processing plants must be equipped with a waterproof apron, draining to a collection point and should be surrounded by a bund or similar structure.
- Drainage from 'dirty' areas must feed into a disinfection facility. A disinfectant spray or wheel bath must be available to treat vehicles leaving a processing plant.
- Wellboats or other vessels should be disinfected after visiting a processing plant, particularly between shuttle runs to different fish farm sites.
- Full protective clothing must be provided for staff and should be kept on site, except for laundering in which case it must be properly contained for transport. Rubber overalls must be disinfected in a soak bath.
- Plastic pallets should be used where possible and these should be disinfected before leaving the processing plant. Wooden pallets should be for 'single use' only.
- Harvest bins must be cleaned and disinfected before leaving the processing plant. Clean bins must be stored in a specified area away from dirty areas.
- Access to dirty areas should be restricted.
- Processing area surfaces should be waterproof and amenable to disinfection. All drainage from these areas must feed into a disinfection facility.
- All liquid effluent from processing operations must be disinfected before disposal.
- All viscera and other solid waste must be treated in an appropriate manner to prevent the spread of disease, meeting in all circumstances the requirements of EC Regulation 1774/2002 and any subsequent legislation.

**Protection from environmental exposure to pathogens**

- Disinfection of water intakes to and effluents from land-based farms where practicable. Measures should always be employed at water intakes to minimise the risk of ingress of wild fish. Twin sets of screens should be used so that wild fish cannot get access to the farm when the screens are being cleaned.
- In cage culture a fallowing policy should be established, based on risk assessment.
- Within land based facilities, farmers should be encouraged to maintain cohort separation, and cleaning and disinfection should be undertaken every time ponds or tanks are vacated and prior to restocking.
- Farmed fish escapes may pose a risk to adjacent farms. Cage security inspection should be reviewed immediately IPN is confirmed on a site and a net inspection programme, if not already in place, should be followed until all fish are removed from the cages. Particular effort should be directed at attempts to recapture escaped salmon that are, or are likely to become, sexually mature.
- Where wrasse are to be introduced into salmon cages for the purposes of sea lice control, such fish should be locally caught if possible.
- Lice control programmes should be applied to minimise the risk of transmission by lice.
- Effective measures should be in place to minimise access by birds and vermin to freshwater and marine farms and especially access to mortalities and fish food.
- Although our knowledge of the ability of mammals to act as vectors of IPN virus is limited, a precautionary approach is recommended. Thus, permitted anti-predator methods should be employed where possible

## Annex 2

### IPNV Disinfection

#### Survival and inactivation

Method	Concentration/Dose	Contact time	Results	Comments	Reference
Heat	60 °C	1 hour	3 log <sub>10</sub> reduction	IPNV in cell culture medium	Vestergård Jørgensen 1974
	60 °C	30 minutes	3 log <sub>10</sub> reduction	IPNV in cell culture medium	MacKelvie & Desautels 1975
	60 °C	8 hours	inactivated	IPNV in cell culture medium	Whipple & Rohovec 1994
	65 °C	3,5 hours	inactivated	IPNV in cell culture medium	Whipple & Rohovec 1994
	70 °C	2 hours	inactivated	IPNV in cell culture medium	Whipple & Rohovec 1994
	80 °C	10 minutes	inactivated	IPNV in cell culture medium	Whipple & Rohovec 1994
UV	1850 – 3000 J/m <sup>2</sup>		3 log <sub>10</sub> reduction	IPNV in cell culture medium	MacKelvie & Desautels 1975
	1500 – 2000 J/m <sup>2</sup>		3 log <sub>10</sub> reduction		Sako & Sorimachi 1985
	1750 – 2000 J/m <sup>2</sup>		3 log <sub>10</sub> reduction		Yoshimizu et al. 1986
	1220 J/m <sup>2</sup>		3 log <sub>10</sub> reduction	IPNV in brackish water	Liltved et al 1995
	1188 J/m <sup>2</sup>		3 log <sub>10</sub> reduction	IPNV in freshwater	Øye & Rimstad 2001
Acid	pH 2,5	Several hours	3 log <sub>10</sub> reduction	IPNV in cell culture medium	Vestergård-Jørgensen 1974
	pH 3 (saltsyre)	6 hours	no effect	IPNV in cell culture medium	Ahne 1982
	pH 2,0 (maursyre)	6 minutes	> 3 log <sub>10</sub> -reduction	IPNV in slaughter effluents	Fløgstad et al. 1991
	pH 3,8	147 days	0,5–2 log <sub>10</sub> -reduction	IPNV in buffer at 4 °C	Smail et al. 1993
	pH 3,8 – 4,3	14 days	survives	IPNV in fish silage at 22 °C	Whipple & Rohovec 1994
Alkali (NaOH)	pH 12,2	< 10 minutes	3 log <sub>10</sub> -reduction	IPNV in cell culture medium	Vestergård Jørgensen 1974
	pH 11,9	5 minutes	inactivated	IPNV in freshwater	Ahne 1982
	pH 12	24 hours	> 3 log <sub>10</sub> -reduction	IPNV in slaughter effluents	Fløgstad et al. 1991
	pH12,4	1 hour	inactivated	IPNV in slaughter effluents	Fløgstad et al. 1991
	Chlorine	25 mg/l	30 minutes	inactivated	IPNV in freshwater, titer 10 <sup>5</sup>
40 mg/l		30 minutes	inactivated	IPNV in freshwater, titer 10 <sup>7,5</sup>	Desautels & MacKelvie 1975
0,7 mg/l		2 minutes	inactivated	IPNV in hard water	Wedemeyer et al. 1978
30 mg/l		30 minutes	2 log <sub>10</sub> -reduction	IPNV in freshwater with soiling	Ahne 1982
30 mg/l		2 minutes	2 log <sub>10</sub> -reduction	IPNV in freshwater	Ahne 1982

Ozone	90 mg/(l×h)	10 minutes	inactivated	IPNV in hard lake water	Wedemeyer et al. 1978
	90 mg/(l×h)	0,5 minutes	inactivated	IPNV in soft lake water	Wedemeyer et al. 1978
	0,10 – 0,20 mg/l	1 minute	4 log <sub>10</sub> reduction	IPNV in lake, brackish and sea water	Liltved et al. 1995
	0,52 mg/l (TRO)	1 minute	> 2 log <sub>10</sub> reduction	IPNV in seawater	Yoshimizu et al. 1995
	0,11 mg/l (TRO)	1 minute	> 2 log <sub>10</sub> reduction	IPNV in sea water	Itoh et al. 1997
Formalin	2 %	5 minutes	3 log <sub>10</sub> reduction	IPNV in cell culture medium	Vestergård Jørgensen 1974
	1:4000 formaldehyde	4 days	3 log <sub>10</sub> reduction	IPNV in buffer	MacKelvie & Desautels 1975
	3 %	5 minutes	inactivated	IPNV in freshwater	Ahne 1982
Iodophores	32 mg/l	5 minutes	inactivated		Amend & Pietsch 1972
	35 mg/l	5 minutes	inactivated	IPNV in buffer	Desautels & MacKelvie 1975



## References

1. Ahne, W. 1982. Vergleichende Untersuchungen über die Stabilität von vier fischpathogenen Viren (VHSV, PFR, SVCV, IPNV). *Zbl. Vet. Med. B*, 29, pp. 457 – 476.
2. Amend, D. F. & Pietsch, J. P. 1972. Virucidal Activity of Two Iodophors to Salmonid Viruses. *J. Fish. Res. Bd. Can* 29, pp. 61 – 65
3. Desautels, D. & MacKelvie R. M. 1975. Practical Aspects of Survival and Destruction of Infectious Pancreatic Necrosis Virus. *J. Fish. Res. Bd. Can* 32(4), pp. 523 - 531
4. Fløgstad, H., Torgersen, Y., Schei, I. & Røttereng, P.J. 1991. Desinfeksjon av blodvann fra fiskeslakterier. STF60 A91096, pp 1 – 101
5. Itoh, S., Yoshimizu, M. & Ezura, Y. 1997. Disinfectant Effects of Low Level of Total Residual Oxidants in Artificial Seawater on Fish Pathogenic Microorganisms. 63. pp 97 – 102
6. Liltvedt, H., Hektoen, H. & Efraimsen, H. Inactivation of Bacterial and Viral Fish Pathogens by Ozonation of UV Irradiation in Water of Different Salinity. *Aquacultural Engineering* 14, pp 107 – 122
7. MacKelvie R. M. & Desautels, D. 1975. Fish Viruses – Survival and Inactivation of Infectious Pancreatic Necrosis Virus. *J. Fish. Res. Bd. Can.* 32, pp 1267 - 1273
8. Sako, H. & Sorimachi, M. 1985. Susceptibility of Fish Pathogenic Viruses, Bacteria and Fungus to Ultraviolet Irradiation and the Disinfectant Effect of U.V.- Ozone Water Sterilizer on the Pathogens in Water. *Bull. Natl. Res. Inst. Aquaculture* No. 8, pp 51-58
9. Smail, D. A., Huntly, P. J. & Munro, A. L. S. 1993. Fate of four fish pathogens after exposure to fish silage containing fish farm mortalities and conditions for the inactivation of infectious. *Agriculture*, 113, pp 173 – 181
10. Vestergård Jørgensen, P. E. 1974. A Study of viral diseases in Danish rainbow trout, their diagnosis and control, pp 0 – 101
11. Yoshimizu, M., Hyuga, S., Oh, M. J., Ito, S., Ezura, Y & Minura, G. 1995. Disinfectant effect of oxidant produced by ozonation of sea water on fish pathogenic viruses, bacteria, and ciliata. *Diseases in Asian Aquaculture II*, pp 203 - 209
12. Yoshimizu, M., Takizawa, H. & Kimura, T. 1986. U.V. Susceptibility of Some Fish Pathogenic Viruses. *Fish Pathology* 21 (1), pp 47 – 52
13. Wedemeyer, G. A., Nelson, N. C. & Smith, C. A 1978. Survival of the Salmonid Viruses Infectious Hematopoietic Necrosis (IHNV) and Infectious Pancreatic Necrosis (IPNV) in Ozonated, Chlorinated, and Untreated Waters. *J. Fish. Res. Bd. Can.* 35, pp 875 - 879
14. Whipple, M. J. & Rohovec, J. S. 1994. The effect of heat and low pH on selected viral and bacterial fish pathogens. *Agriculture* 123, pp 179 – 189
15. Øye, A.K. & Rimstad, E. 2001. Inactivation of infectious salmon anaemia virus, viral haemorrhagic septicaemia virus and infectious pancreatic necrosis virus in water using UVC irradiation. *Diseases of aquatic organisms*, 48 (1)

