

# PRELIMINARY INFORMATION



## **787** **Airplane Characteristics for** **Airport Planning**



# PRELIMINARY INFORMATION

## 787 AIRPLANE CHARACTERISTICS FOR AIRPORT PLANNING LIST OF ACTIVE PAGES

Page	Date	Page	Date	Page	Date
Original i to 110	April 2006				
Rev A i to 110	September 2007				
Page 54	January 2008				
Page 55	January 2008				
Page 76	December 2007				
Page 78	December 2007				
Page 94	February 2008				
Page 95	February 2008				

# PRELIMINARY INFORMATION

## TABLE OF CONTENTS

<u>SECTION</u>	<u>TITLE</u>	<u>PAGE</u>
1.0	SCOPE AND INTRODUCTION	1
1.1	Scope	2
1.2	Introduction	3
1.3	A Brief Description of the 787 Family of Airplanes	4
2.0	AIRPLANE DESCRIPTION	5
2.1	General Characteristics	6
2.2	General Dimensions	8
2.3	Ground Clearances	9
2.4	Interior Arrangements	10
2.5	Cabin Cross-Sections	13
2.6	Lower Cargo Compartments	15
2.7	Door Clearances	16
3.0	AIRPLANE PERFORMANCE	21
3.1	General Information	22
3.2	Payload/Range for Long-Range Cruise	23
3.3	F.A.R. Takeoff Runway Length Requirements	25
3.4	F.A.R. Landing Runway Length Requirements	33
4.0	GROUND MANEUVERING	37
4.1	General Information	38
4.2	Turning Radii	39
4.3	Clearance Radii	40
4.4	Visibility from Cockpit in Static Position	41
4.5	Runway and Taxiway Turn Paths	42
4.6	Runway Holding Bay	47
5.0	TERMINAL SERVICING	49
5.1	Airplane Servicing Arrangement - Typical Turnaround	51
5.2	Terminal Operations - Turnaround Station	52
5.3	Terminal Operations - En Route Station	53
5.4	Ground Servicing Connections and Capacities	54
5.5	Engine Start and Ground Power Requirements	56
5.6	Conditioned Air Flow Requirements	58
5.7	Ground Towing Requirements	61

# PRELIMINARY INFORMATION

## TABLE OF CONTENTS (CONTINUED)

<u>SECTION</u>	<u>TITLE</u>	<u>PAGE</u>
6.0	JET ENGINE WAKE AND NOISE DATA	63
6.1	Jet Engine Exhaust Velocities and Temperatures	64
6.2	Airport and Community Noise	71
7.0	PAVEMENT DATA	75
7.1	General Information	76
7.2	Landing Gear Footprint	79
7.3	Maximum Pavement Loads	80
7.4	Landing Gear Loading on Pavement	81
7.5	Flexible Pavement Requirements - U.S. Army Corps of Engineers Method (S-77-1)	82
7.6	Flexible Pavement Requirements - LCN Method	84
7.7	Rigid Pavement Requirements - Portland Cement Association Design Method	86
7.8	Rigid Pavement Requirements - LCN Conversion	88
7.9	Rigid Pavement Requirements - FAA Method	91
7.10	ACN/PCN Reporting System - Flexible and Rigid Pavements	93
8.0	FUTURE 787 DERIVATIVE AIRPLANES	97
9.0	SCALED 787 DRAWINGS	99

# PRELIMINARY INFORMATION

## **1.0 SCOPE AND INTRODUCTION**

### **1.1 Scope**

### **1.2 Introduction**

### **1.3 A Brief Description of the 787 Family of Airplanes**

# PRELIMINARY INFORMATION

## 1.0 SCOPE AND INTRODUCTION

### 1.1 Scope

This document provides, in a standardized format, airplane characteristics data for general airport planning. Since operational practices vary among airlines, specific data should be coordinated with the using airlines prior to facility design. Boeing Commercial Airplanes should be contacted for any additional information required.

Content of the document reflects the results of a coordinated effort by representatives from the following organizations:

- Aerospace Industries Association
- Airports Council International - North America
- Air Transport Association of America
- International Air Transport Association

The airport planner may also want to consider the information presented in the "Commercial Aircraft Design Characteristics – Trends and Growth Projections," available from the US AIA, 1250 Eye St., Washington DC 20005, for long-range planning needs. This document is updated periodically and represents the coordinated efforts of the following organizations regarding future aircraft growth trends:

- International Coordinating Council of Aerospace Industries Associations
- Airports Council International - North American and World Organizations
- Air Transport Association of America
- International Air Transport Association

# PRELIMINARY INFORMATION

## 1.2 Introduction

This document conforms to NAS 3601. It provides characteristics of the Boeing Model 787 airplane for airport planners and operators, airlines, architectural and engineering consultant organizations, and other interested industry agencies. Airplane changes and available options may alter model characteristics; the data presented herein reflect typical airplanes in each model category.

For additional information contact:

Boeing Commercial Airplanes  
P.O. Box 3707  
Seattle, Washington 98124-2207  
U.S.A.

Attention: Manager, Airport Technology  
Mail Code 67-KR  
Email: [AirportTechnology@boeing.com](mailto:AirportTechnology@boeing.com)  
Website: [www.boeing.com/airports](http://www.boeing.com/airports)

# PRELIMINARY INFORMATION

## **1.3 A Brief Description of the 787 Family of Airplanes**

The 787 is a family of twin-engine airplanes, very fuel efficient and with exceptional environmental performance. The 787 airplanes are being developed by an International team of aerospace companies, led by Boeing at its Everett Facility near Seattle, Washington. Using a suite of new technologies, as much as 50 percent of the primary structure will be composite materials.

### **787-8**

The 787-8 is the first airplane in the 787 family of twin-engine airplanes and is designed for medium to long range flights. The 787-8 can carry 210 to 250 passengers in a three-class configuration and up to 375 passengers in a single-class configuration.

### **787 Engines**

General Electric and Rolls-Royce have been selected to develop engines using advanced engine technology for increased efficiency of the 787 airplane.

### **Cargo Handling**

The lower lobe cargo compartments can accommodate a variety of containers and pallets now used in narrow-body and wide-body airplanes.

### **Ground Servicing**

The 787 airplane is an all-electric airplane and as such will not have a pneumatic system onboard. The airplane has ground service connections compatible with existing ground service equipment, and no special equipment is necessary. In case of an inoperable APU, engine starts may be accomplished via the airplane body electrical connections.



# PRELIMINARY INFORMATION

## **2.0 AIRPLANE DESCRIPTION**

### **2.1 General Characteristics**

### **2.2 General Dimensions**

### **2.3 Ground Clearances**

### **2.4 Interior Arrangements**

### **2.5 Cabin Cross Sections**

### **2.6 Lower Cargo Compartments**

### **2.7 Door Clearances**

# PRELIMINARY INFORMATION

## 2.0 AIRPLANE DESCRIPTION

### 2.1 General Characteristics

Maximum Design Taxi Weight (MTW). Maximum weight for ground maneuver as limited by aircraft strength and airworthiness requirements. (It includes weight of taxi and run-up fuel.)

Maximum Design Takeoff Weight (MTOW). Maximum weight for takeoff as limited by aircraft strength and airworthiness requirements. (This is the maximum weight at start of the takeoff run.)

Maximum Design Landing Weight (MLW). Maximum weight for landing as limited by aircraft strength and airworthiness requirements.

Maximum Design Zero Fuel Weight (MZFW). Maximum weight allowed before usable fuel and other specified usable agents must be loaded in defined sections of the aircraft as limited by strength and airworthiness requirements.

Spec Operating Empty Weight (OEW). Weight of structure, powerplant, furnishing systems, unusable fuel and other unusable propulsion agents, and other items of equipment that are considered an integral part of a particular airplane configuration. Also included are certain standard items, personnel, equipment, and supplies necessary for full operations, excluding usable fuel and payload.

Maximum Structural Payload. Maximum design zero fuel weight minus operational empty weight.

Maximum Seating Capacity. The maximum number of passengers specifically certificated or anticipated for certification.

Maximum Cargo Volume. The maximum space available for cargo.

Usable Fuel. Fuel available for aircraft propulsion.

# PRELIMINARY INFORMATION

CHARACTERISTICS	UNITS	ENGINE MANUFACTURER	
		GENERAL ELECTRIC	ROLLS-ROYCE
MAX DESIGN	POUNDS	486,000	486,000
TAXI WEIGHT	KILOGRAMS	220,445	220,445
MAX DESIGN	POUNDS	484,000	484,000
TAKEOFF WEIGHT	KILOGRAMS	219,539	219,539
MAX DESIGN	POUNDS	370,000	370,000
LANDING WEIGHT	KILOGRAMS	167,829	167,829
MAX DESIGN ZERO	POUNDS	345,000	345,000
FUEL WEIGHT	KILOGRAMS	156,490	156,490
SPEC OPERATING	POUNDS	252,500	252,500
EMPTY WEIGHT (1)	KILOGRAMS	114,532	114,532
MAX STRUCTURAL	POUNDS	100,000	100,000
PAYLOAD	KILOGRAMS	45,359	45,359
SEATING	ONE-CLASS	375 ALL-ECONOMY SEATS; EXIT LIMIT = 440 SEATS	
CAPACITY	MIXED CLASS	224 THREE-CLASS; 12 FIRST CLASS, 42 BUSINESS CLASS, 170 ECONOMY CLASS (SEE SEC 2.4)	
MAX CARGO	CUBIC FEET	4,826 (2)	4,826 (2)
- LOWER DECK	CUBIC METERS	136.7 (2)	136.7 (2)
USABLE FUEL	US GALLONS	33,528	33,528
	LITERS	126,903	126,903
	POUNDS	224,638	224,638
	KILOGRAMS	101,894	101,894

- NOTES: (1) SPEC WEIGHT FOR TYPICAL ENGINE / WEIGHT CONFIGURATION SHOWN  
TYPICAL OPERATING EMPTY WEIGHT SHOWN. ACTUAL WEIGHT WILL  
DEPEND ON SPECIFIC AIRLINE CONFIGURATION.
- (2) 16 LD3 CONTAINERS IN FWD COMPARTMENT AT 158 CU FT (4.5 CU M) EACH ; 12 LD3  
CONTAINERS IN AFT COMPARTMENT; 402 CU FT (11.4 CU M) IN BULK CARGO COMPARTMENT.  
SEE SEC 2.6 FOR OTHER LOADING COMBINATIONS.

## 2.1 GENERAL CHARACTERISTICS

*MODEL 787-8*

D6-58333

# PRELIMINARY INFORMATION

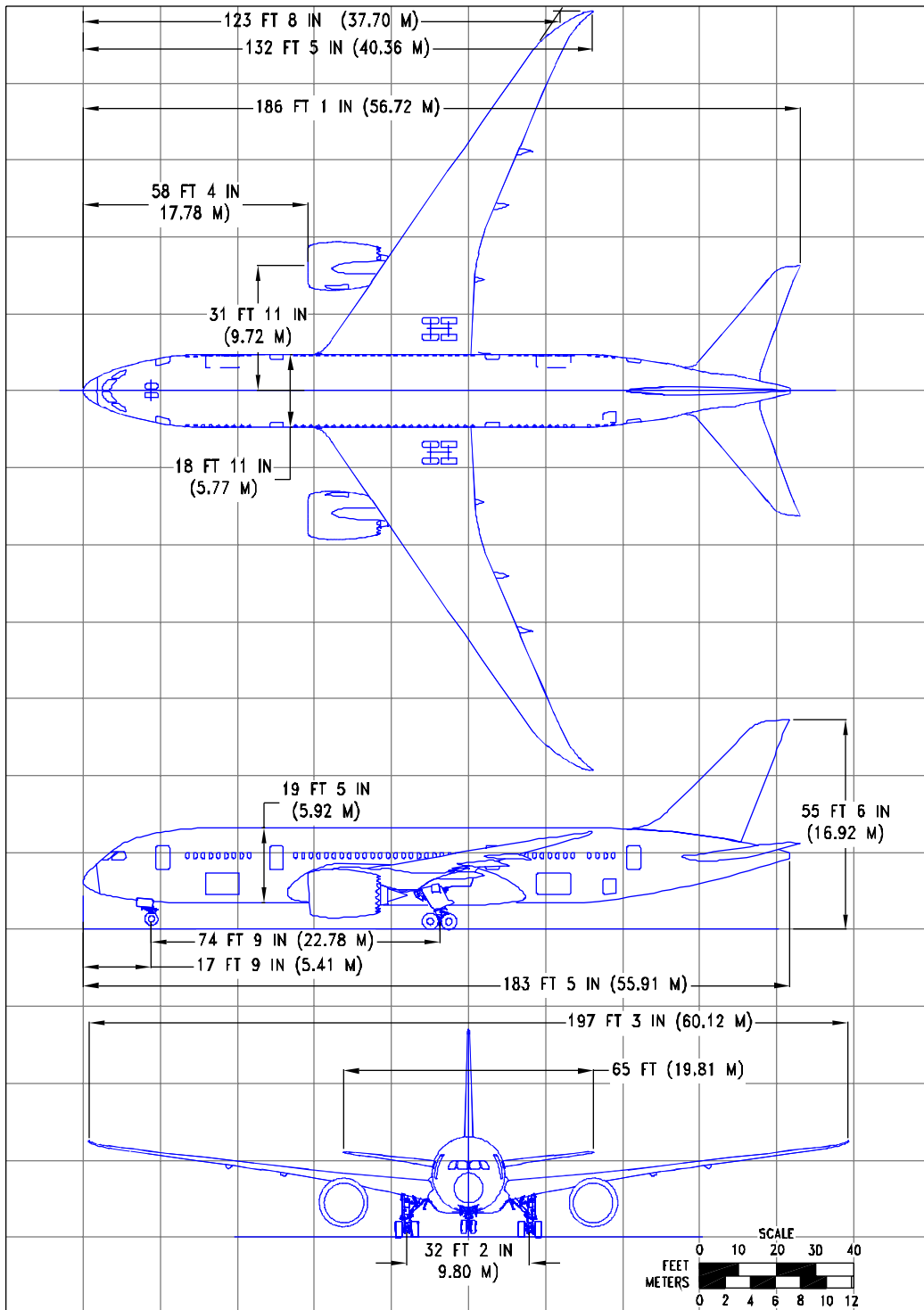

## 2.2 GENERAL DIMENSIONS

MODEL 787-8

# PRELIMINARY INFORMATION

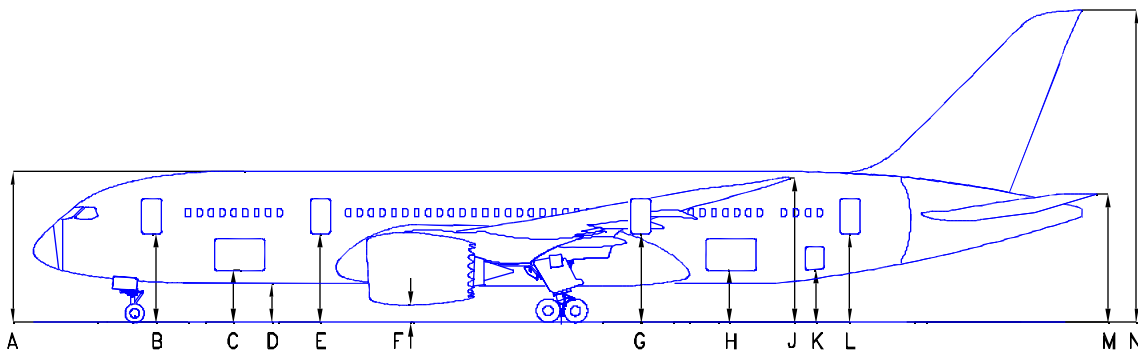

	NOMINAL (1)	
	FEET - INCHES	METERS
A	25 - 3	7.70
B	14 - 2	4.32
C	8 - 0	2.44
D	5 - 9	1.75
E	14 - 7	4.45
F (GE ENGINES)	2 - 5	0.74
F (RR ENGINES)	2 - 4	0.71
G	15 - 4	4.67
H	9 - 2	2.79
J	25 - 2	7.67
K	9 - 6	2.90
L	15 - 10	4.83
M	23 - 5	7.13
N	55 - 6	16.92

NOTES:

1. NOMINAL DIMENSIONS BASED ON A STATIC AIRPLANE.
2. DURING ROUTINE SERVICING, THE AIRPLANE REMAINS RELATIVELY STABLE, PITCH AND ELEVATION CHANGES OCCURRING SLOWLY.

## 2.3 GROUND CLEARANCES

*MODEL 787-8*

# PRELIMINARY INFORMATION

DATA TO BE PROVIDED  
AT A LATER DATE

For more information about the data on this page please contact us at:

e-mail: [AirportTechnology@boeing.com](mailto:AirportTechnology@boeing.com)

OR

Fax: 425-237-8281

## **2.4.1 INTERIOR ARRANGEMENTS – LONG-RANGE CONFIGURATIONS**

*MODEL 787-8*

# PRELIMINARY INFORMATION

DATA TO BE PROVIDED  
AT A LATER DATE

For more information about the data on this page please contact us at:

e-mail: [AirportTechnology@boeing.com](mailto:AirportTechnology@boeing.com)

OR

Fax: 425-237-8281

## **2.4.2 INTERIOR ARRANGEMENTS – SHORT-TO-MEDIUM-TO-LONG RANGE**

*MODEL 787-8*

# PRELIMINARY INFORMATION

DATA TO BE PROVIDED  
AT A LATER DATE

For more information about the data on this page please contact us at:

e-mail: [AirportTechnology@boeing.com](mailto:AirportTechnology@boeing.com)

OR

Fax: 425-237-8281

## **2.4.3 INTERIOR ARRANGEMENTS – SHORT-TO-MEDIUM RANGE**

*MODEL 787-8*



# PRELIMINARY INFORMATION

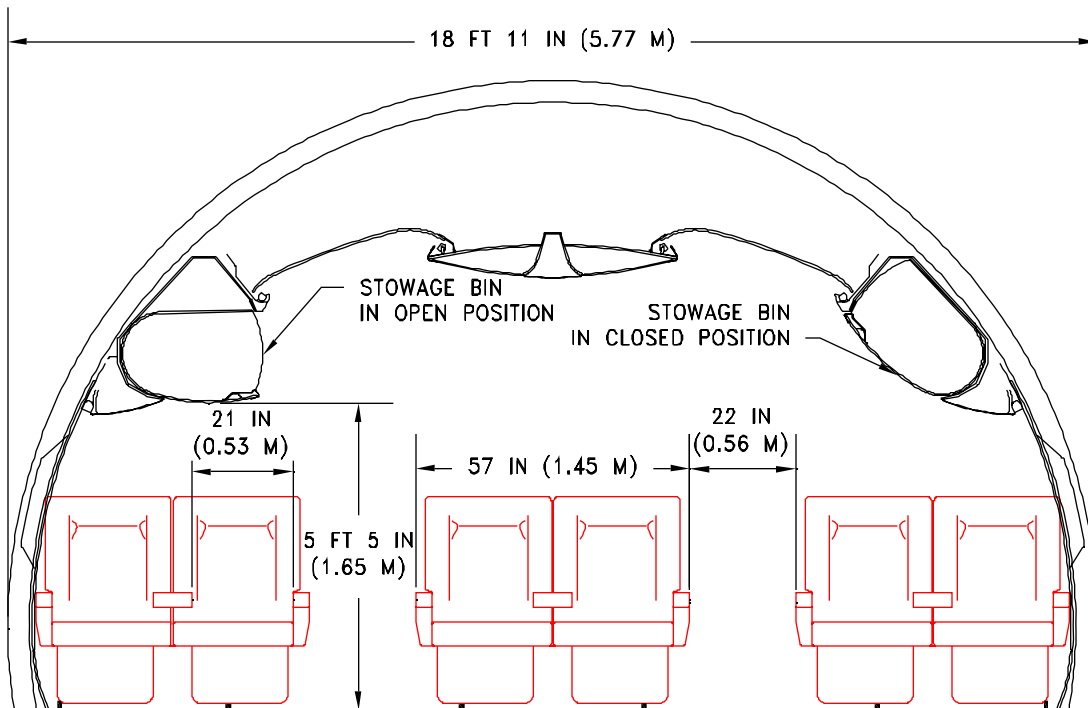

FIRST CLASS/BUSINESS CLASS SEATS

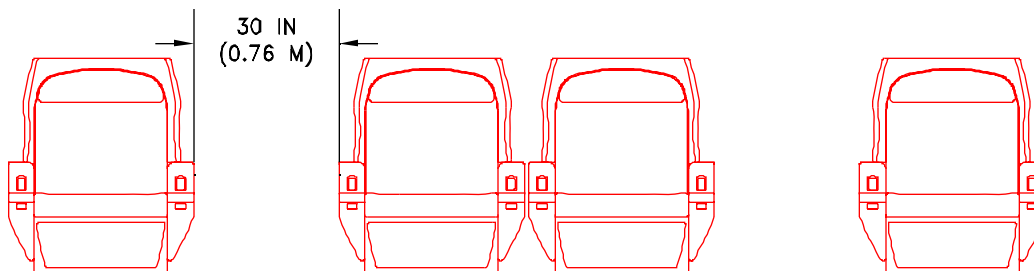

FIRST CLASS POD

## 2.5.1 CABIN CROSS-SECTIONS – FIRST CLASS AND BUSINESS CLASS SEATS MODEL 787-8

# PRELIMINARY INFORMATION

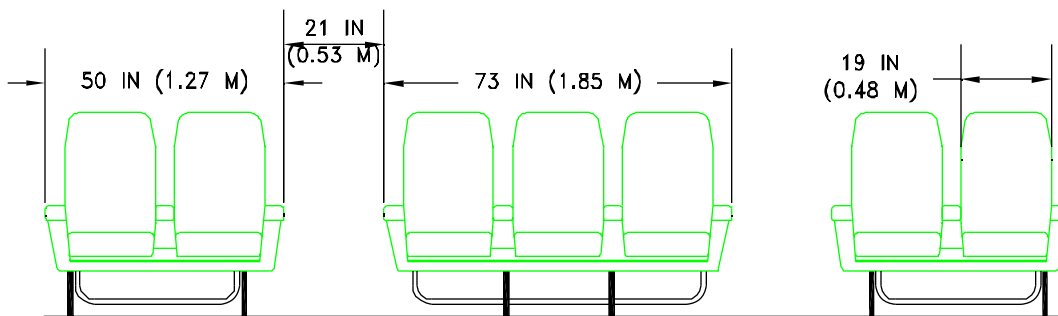

BUSINESS CLASS/PREMIUM ECONOMY CLASS SEATS

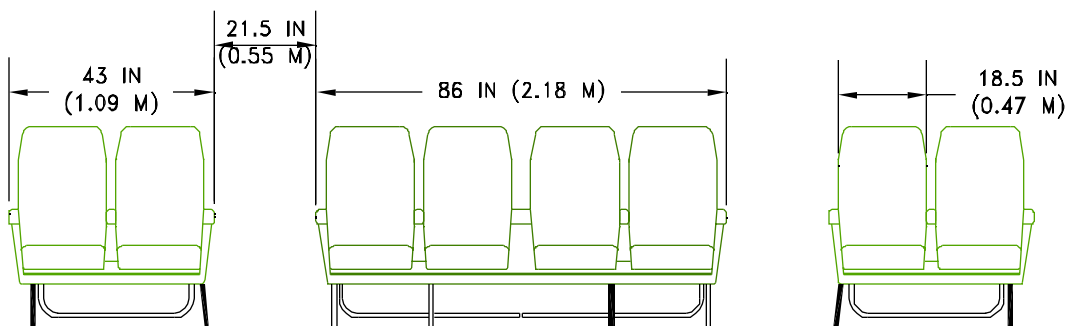

8-ABREAST ECONOMY SEATS

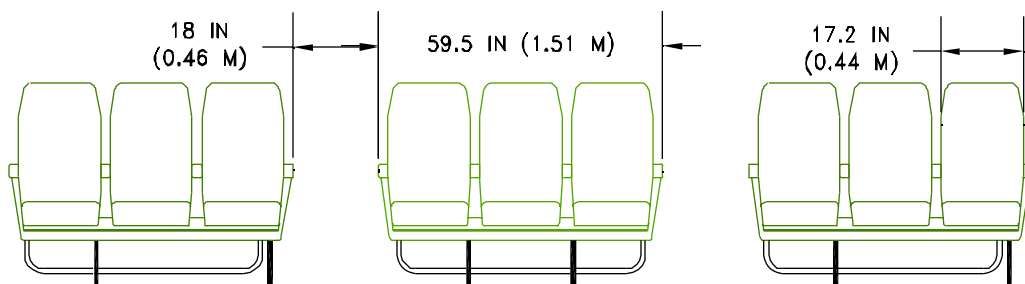

9-ABREAST ECONOMY SEATS

## 2.5.2 CABIN CROSS-SECTIONS - ALTERNATE SEATING ARRANGEMENTS

MODEL 787-8

# PRELIMINARY INFORMATION

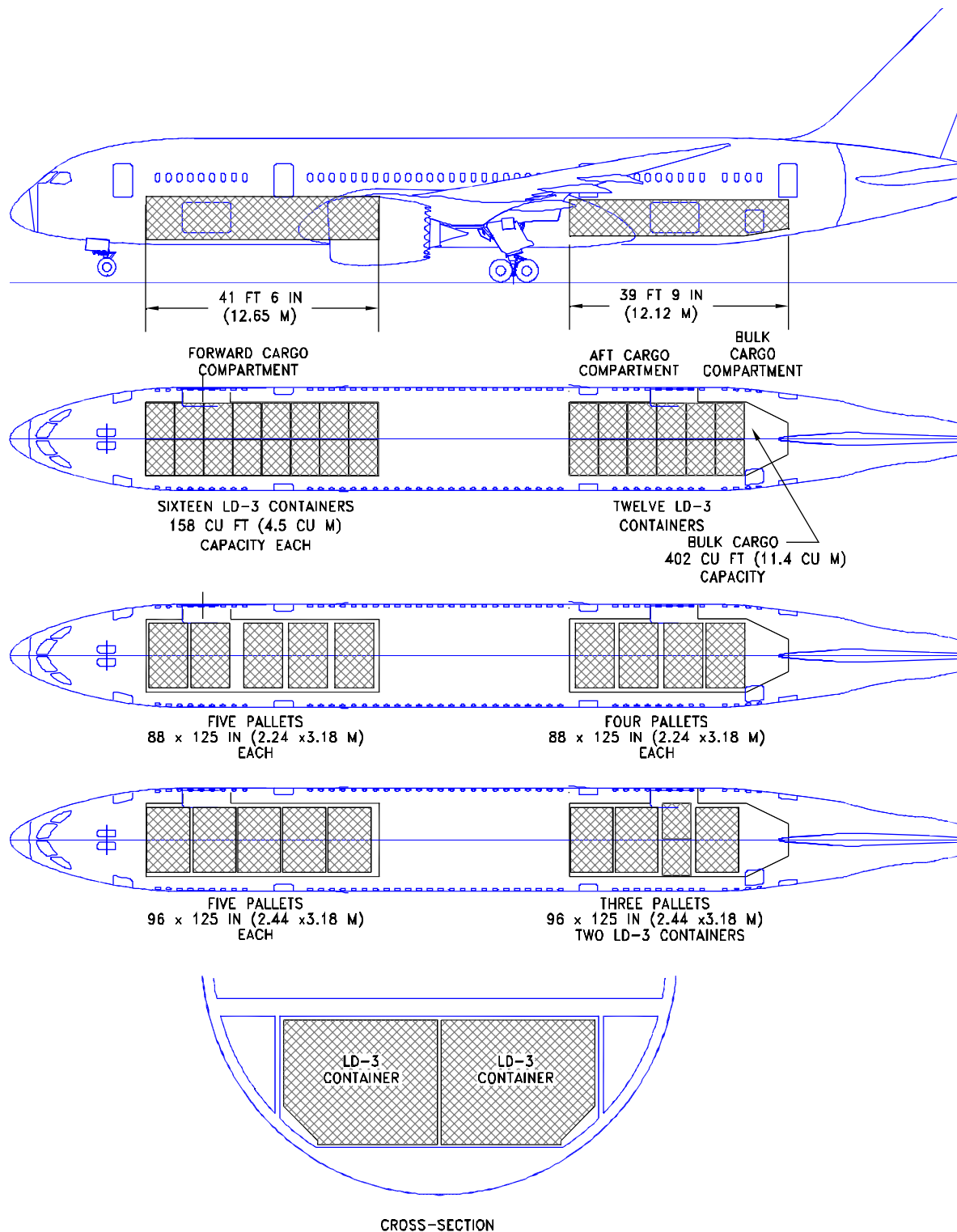

## 2.6 LOWER CARGO COMPARTMENTS – CONTAINERS AND BULK CARGO MODEL 787-8

# PRELIMINARY INFORMATION

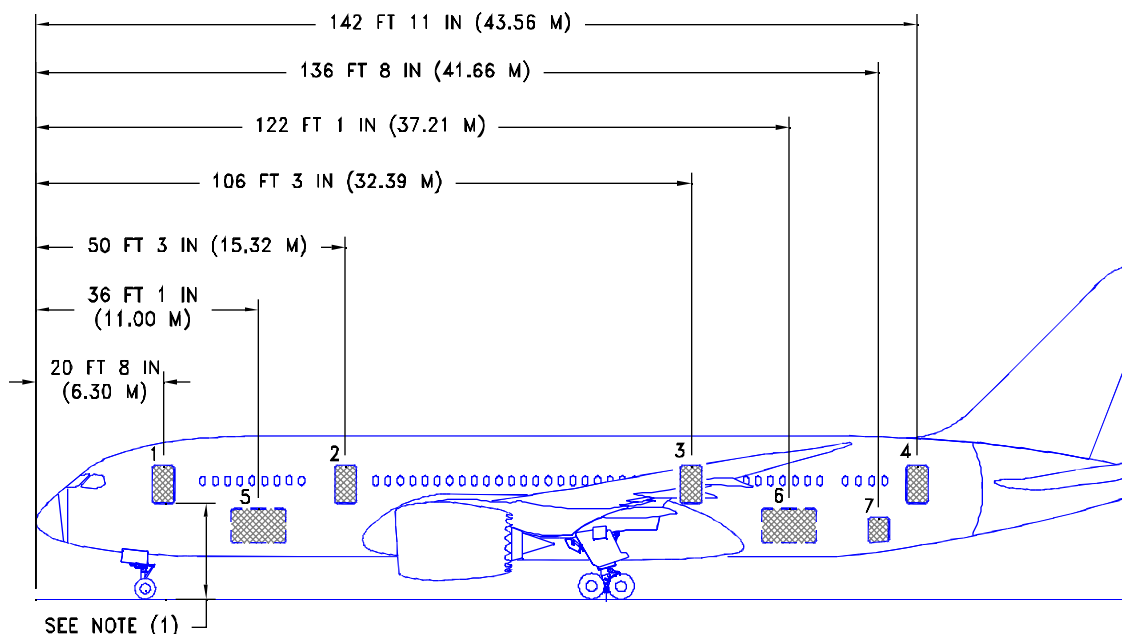

	DOOR NAME	DOOR LOCATION	DOOR CLEAR OPENING
1	MAIN ENTRY/SERVICE DOOR NO 1 (2)	LEFT AND RIGHT	42 IN x 72 IN (1.07 x 1.83 M)
2	MAIN ENTRY/SERVICE DOOR NO 2 (2)	LEFT AND RIGHT	42 IN x 72 IN (1.07 x 1.83 M)
3	EMERGENCY EXIT DOOR NO 3	LEFT AND RIGHT	36 IN x 74 IN (0.91 x 1.88 M)
4	MAIN ENTRY/SERVICE DOOR NO 4 (2)	LEFT AND RIGHT	42 IN x 72 IN (1.07 x 1.83 M)
5	FORWARD CARGO DOOR	RIGHT	106 IN x 67 IN (2.69 x 1.70 M)
6	AFT CARGO DOOR	RIGHT	106 IN x 67 IN (2.69 x 1.70 M)
7	BULK CARGO DOOR	LEFT	40 IN x 45 IN (1.02 x 1.14 M)

NOTES:

- (1) SEE SEC 2.3 FOR DOOR SILL HEIGHTS
- (2) ENTRY DOORS LEFT SIDE, SERVICE DOORS RIGHT SIDE

## 2.7.1 DOOR LOCATIONS AND SIZES - PASSENGER AND CARGO DOORS

MODEL 787-8

# PRELIMINARY INFORMATION

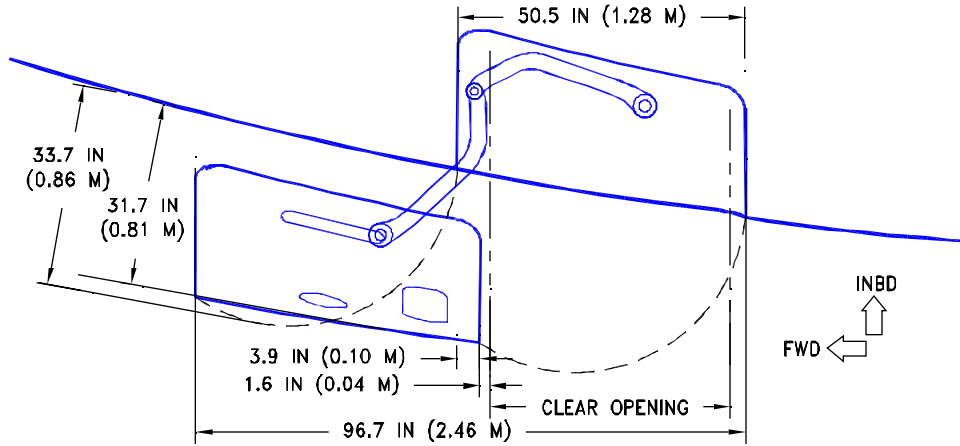

DOOR NO 1 SWING ENVELOP  
(LEFT DOOR SHOWN, RIGHT DOOR OPPOSITE)

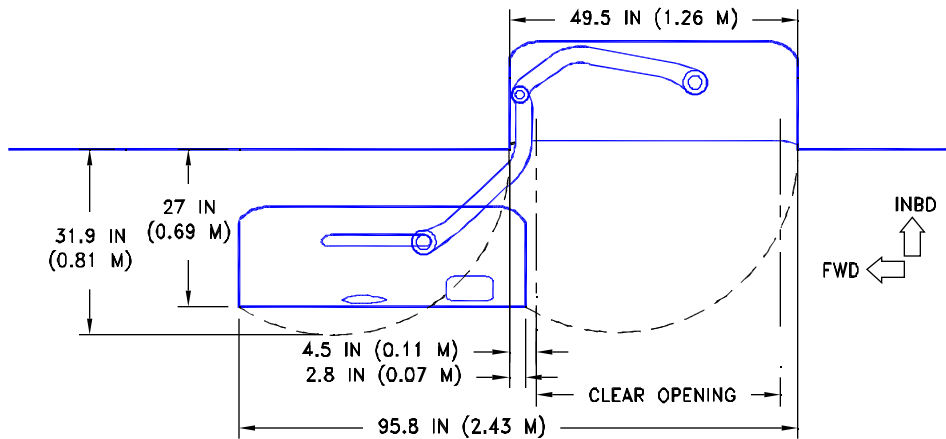

DOOR NO 2 SWING ENVELOP  
(LEFT DOOR SHOWN, RIGHT DOOR OPPOSITE)

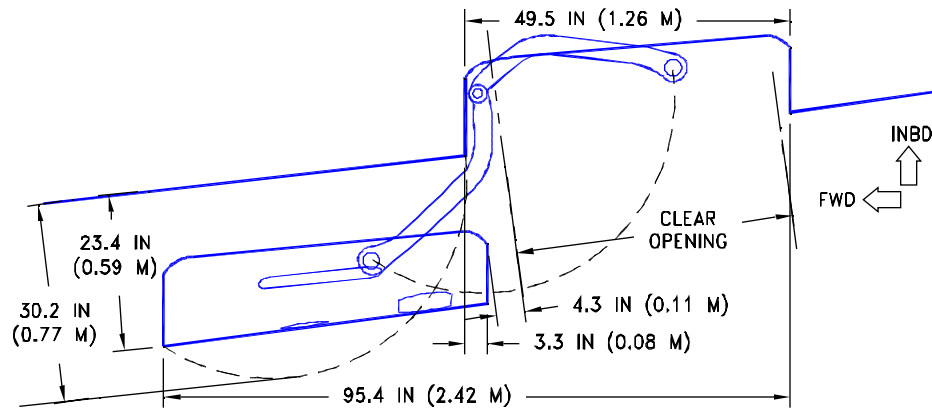

DOOR NO 4 SWING ENVELOP  
(LEFT DOOR SHOWN, RIGHT DOOR OPPOSITE)

## 2.7.2 DOOR CLEARANCES – MAIN DECK ENTRY AND SERVICE DOORS MODEL 787-8

# PRELIMINARY INFORMATION

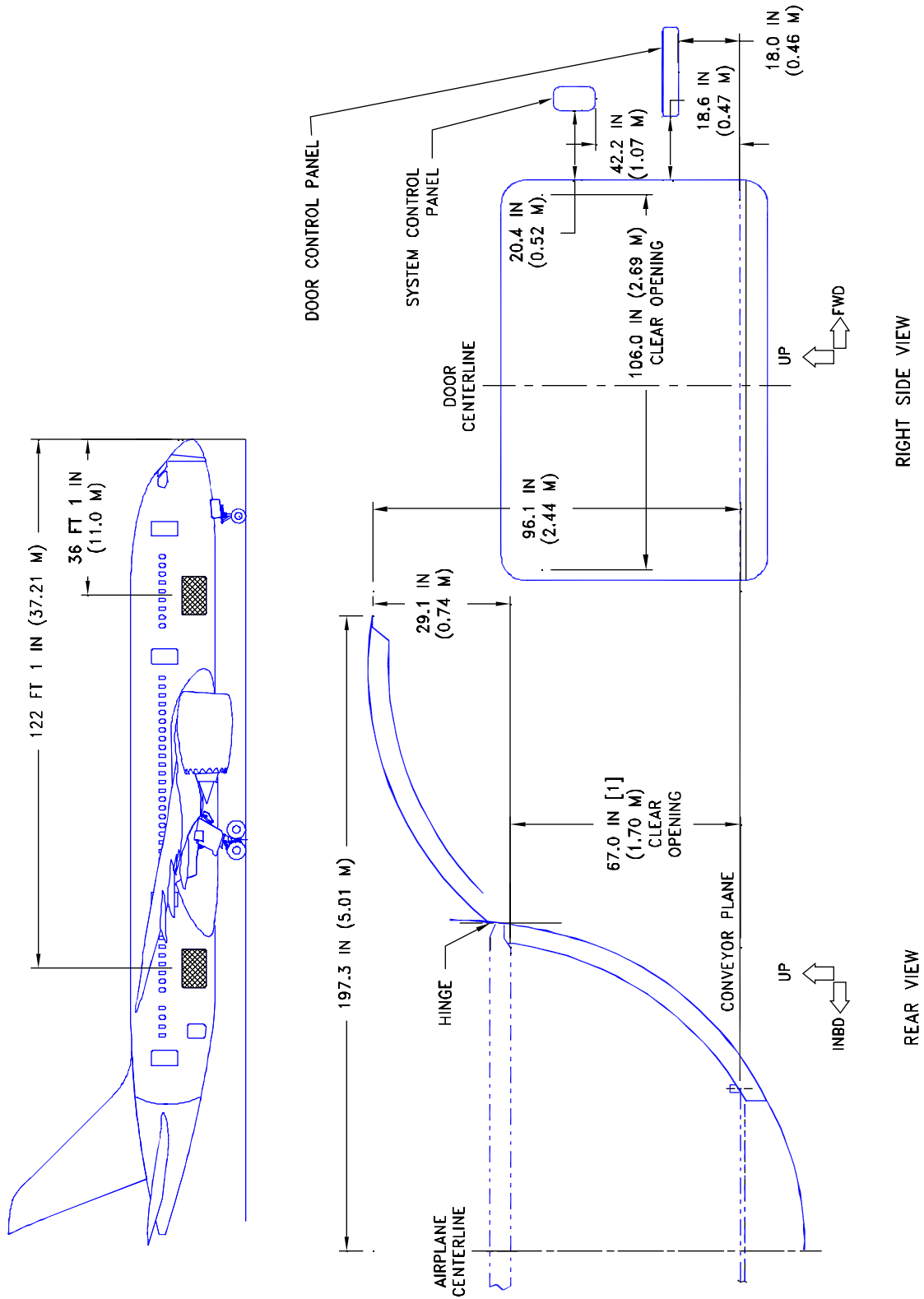

## 2.7.3 DOOR CLEARANCES – LOWER DECK CARGO DOOR MODEL 787-8

# PRELIMINARY INFORMATION

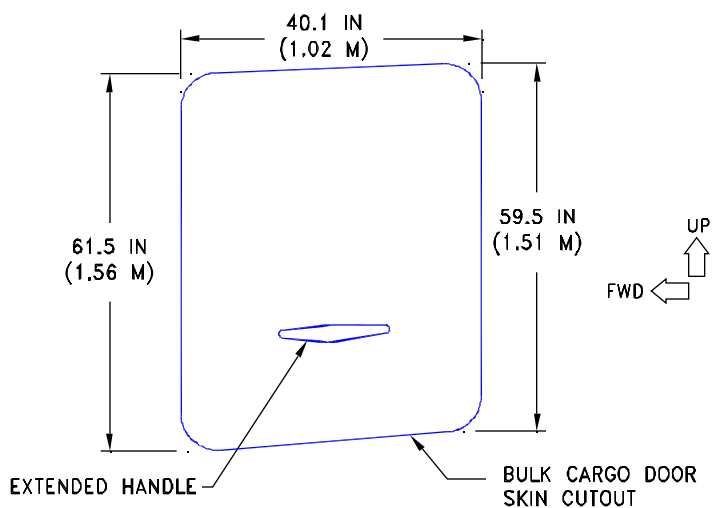
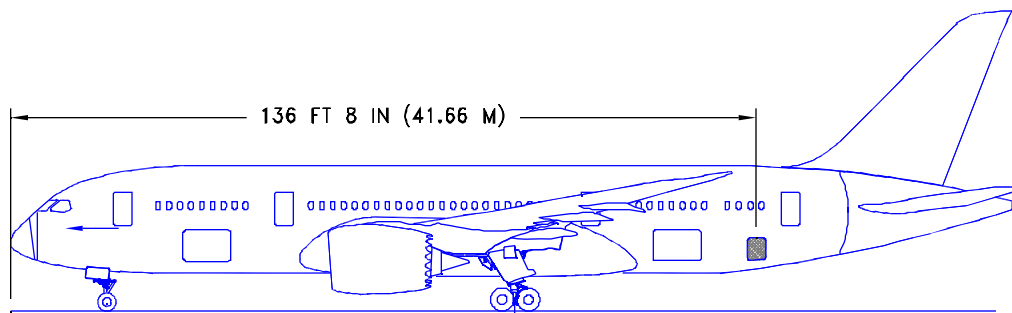

LEFT SIDE VIEW

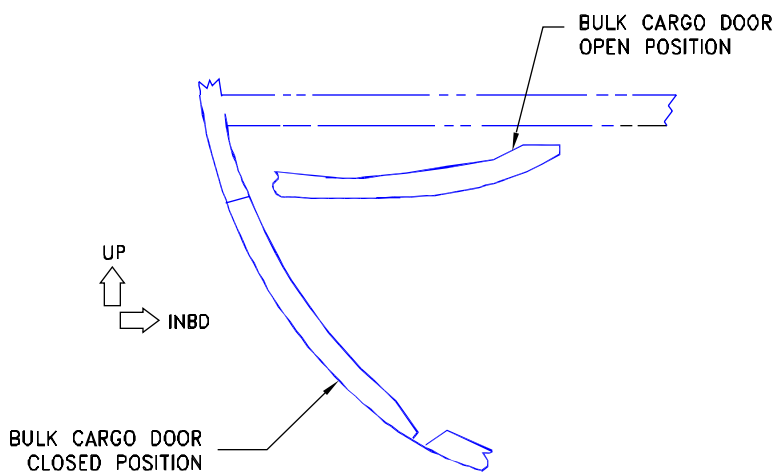

VIEW LOOKING FORWARD

## 2.7.4 DOOR CLEARANCES - BULK CARGO DOOR

MODEL 787-8

# PRELIMINARY INFORMATION

THIS PAGE INTENTIONALLY LEFT BLANK



# PRELIMINARY INFORMATION

## **3.0 AIRPLANE PERFORMANCE**

### **3.1 General Information**

### **3.2 Payload/Range**

### **3.3 F.A.R. Takeoff Runway Length Requirements**

### **3.4 F.A.R. Landing Runway Length Requirements**

# PRELIMINARY INFORMATION

## 3.0 AIRPLANE PERFORMANCE

### 3.1 General Information

The graph in Section 3.2 provides information on operational empty weight (OEW) and payload, trip range, brake release gross weight, and fuel limits for typical 787-8 airplanes. To use this graph, if the trip range and zero fuel weight (OEW + payload) are known, the approximate brake release weight can be found, limited by fuel quantity.

The graphs in Section 3.3 provide information on F.A.R. takeoff runway length requirements with typical engines at different pressure altitudes. Maximum takeoff weights shown on the graphs are the heaviest for the particular airplane models with the corresponding engines. Standard day temperatures for pressure altitudes shown on the F.A.R. takeoff graphs are given below:

PRESSURE ALTITUDE		STANDARD DAY TEMP	
FEET	METERS	°F	°C
0	0	59.0	15.00
2,000	610	51.9	11.04
4,000	1,219	44.7	7.06
6,000	1,829	37.6	3.11
8,000	2,438	30.5	-0.85
10,000	3,048	23.3	-4.81

For airplanes which are governed by the European Joint Airworthiness Authorities (JAA), the wet runway performance is shown in accordance with JAR-OPS 1 Subpart F, with wet runways defined in Paragraph 1.480(a)(10). Skid-resistant runways (grooved or PFC treated) per FAA or ICAO specifications exhibit runway length requirements that remove some or all of the length penalties associated with smooth (non-grooved) runways. Under predominantly wet conditions, the wet runway performance characteristics may be used to determine runway length requirements, if it is longer than the dry runway performance requirements.

The graph in Section 3.4 provides information on landing runway length requirements for different airplane weights and airport altitudes. The maximum landing weights shown are the heaviest for the particular airplane model.

# PRELIMINARY INFORMATION

DATA TO BE PROVIDED  
AT A LATER DATE

For more information about the data on this page please contact us at:

e-mail: [AirportTechnology@boeing.com](mailto:AirportTechnology@boeing.com)

OR

Fax: 425-237-8281

## **3.2.1 PAYLOAD/RANGE FOR LONG-RANGE CRUISE**

*MODEL 787-8 (GENERAL ELECTRIC ENGINES)*

# PRELIMINARY INFORMATION

DATA TO BE PROVIDED  
AT A LATER DATE

For more information about the data on this page please contact us at:

e-mail: [AirportTechnology@boeing.com](mailto:AirportTechnology@boeing.com)

OR

Fax: 425-237-8281

## **3.2.2 PAYLOAD/RANGE FOR LONG-RANGE CRUISE**

*MODEL 787-8 (ROLLS-ROYCE ENGINES)*

# PRELIMINARY INFORMATION

DATA TO BE PROVIDED  
AT A LATER DATE

For more information about the data on this page please contact us at:

e-mail: [AirportTechnology@boeing.com](mailto:AirportTechnology@boeing.com)

OR

Fax: 425-237-8281

**3.3.1 F.A.R. TAKEOFF RUNWAY LENGTH REQUIREMENTS - STANDARD DAY, DRY RUNWAY**  
*MODEL 787-8 (GENERAL ELECTRIC ENGINES)*

# PRELIMINARY INFORMATION

DATA TO BE PROVIDED  
AT A LATER DATE

For more information about the data on this page please contact us at:

e-mail: [AirportTechnology@boeing.com](mailto:AirportTechnology@boeing.com)

OR

Fax: 425-237-8281

**3.3.2 F.A.R. TAKEOFF RUNWAY LENGTH REQUIREMENTS**  
**STANDARD DAY +27°F (STD + 15°C), DRY RUNWAY**  
*MODEL 787-8 (GENERAL ELECTRIC ENGINES)*

# PRELIMINARY INFORMATION

DATA TO BE PROVIDED  
AT A LATER DATE

For more information about the data on this page please contact us at:

e-mail: [AirportTechnology@boeing.com](mailto:AirportTechnology@boeing.com)

OR

Fax: 425-237-8281

**3.3.3 J.A.R. TAKEOFF RUNWAY LENGTH REQUIREMENTS – STANDARD DAY, WET RUNWAY**  
*MODEL 787-8 (GENERAL ELECTRIC ENGINES)*

# PRELIMINARY INFORMATION

DATA TO BE PROVIDED  
AT A LATER DATE

For more information about the data on this page please contact us at:

e-mail: [AirportTechnology@boeing.com](mailto:AirportTechnology@boeing.com)

OR

Fax: 425-237-8281

**3.3.4 J.A.R. TAKEOFF RUNWAY LENGTH REQUIREMENTS**  
**STANDARD DAY +27°F (STD + 15°C), WET RUNWAY**  
*MODEL 787-8 (GENERAL ELECTRIC ENGINES)*



# PRELIMINARY INFORMATION

DATA TO BE PROVIDED  
AT A LATER DATE

For more information about the data on this page please contact us at:

e-mail: [AirportTechnology@boeing.com](mailto:AirportTechnology@boeing.com)

OR

Fax: 425-237-8281

**3.3.5 F.A.R. TAKEOFF RUNWAY LENGTH REQUIREMENTS - STANDARD DAY, DRY RUNWAY**  
*MODEL 787-8 (ROLLS-ROYCE ENGINES)*

# PRELIMINARY INFORMATION

DATA TO BE PROVIDED  
AT A LATER DATE

For more information about the data on this page please contact us at:

e-mail: [AirportTechnology@boeing.com](mailto:AirportTechnology@boeing.com)

OR

Fax: 425-237-8281

**3.3.6 F.A.R. TAKEOFF RUNWAY LENGTH REQUIREMENTS**  
**STANDARD DAY + 27°F (STD + 15°C), DRY RUNWAY**  
*MODEL 787-8 (ROLLS-ROYCE ENGINES)*

# PRELIMINARY INFORMATION

DATA TO BE PROVIDED  
AT A LATER DATE

For more information about the data on this page please contact us at:

e-mail: [AirportTechnology@boeing.com](mailto:AirportTechnology@boeing.com)

OR

Fax: 425-237-8281

**3.3.7 J.A.R. TAKEOFF RUNWAY LENGTH REQUIREMENTS – STANDARD DAY, WET RUNWAY**  
*MODEL 787-8 (ROLLS-ROYCE ENGINES)*

# PRELIMINARY INFORMATION

DATA TO BE PROVIDED  
AT A LATER DATE

For more information about the data on this page please contact us at:

e-mail: [AirportTechnology@boeing.com](mailto:AirportTechnology@boeing.com)

OR

Fax: 425-237-8281

**3.3.8 J.A.R. TAKEOFF RUNWAY LENGTH REQUIREMENTS**  
**STANDARD DAY + 27°F (STD + 15°C), WET RUNWAY**  
*MODEL 787-8 (ROLLS-ROYCE ENGINES)*

# PRELIMINARY INFORMATION

DATA TO BE PROVIDED  
AT A LATER DATE

For more information about the data on this page please contact us at:

e-mail: [AirportTechnology@boeing.com](mailto:AirportTechnology@boeing.com)

OR

Fax: 425-237-8281

**3.4.1 F.A.R. LANDING RUNWAY LENGTH REQUIREMENTS - FLAPS 30**  
*MODEL 787-8, (GENERAL ELECTRIC ENGINES)*

# PRELIMINARY INFORMATION

DATA TO BE PROVIDED  
AT A LATER DATE

For more information about the data on this page please contact us at:

e-mail: [AirportTechnology@boeing.com](mailto:AirportTechnology@boeing.com)

OR

Fax: 425-237-8281

**3.4.2 F.A.R. LANDING RUNWAY LENGTH REQUIREMENTS - FLAPS 25**  
*MODEL 787-8 (GENERAL ELECTRIC ENGINES)*

# PRELIMINARY INFORMATION

DATA TO BE PROVIDED  
AT A LATER DATE

For more information about the data on this page please contact us at:

e-mail: [AirportTechnology@boeing.com](mailto:AirportTechnology@boeing.com)

OR

Fax: 425-237-8281

**3.4.3 F.A.R. LANDING RUNWAY LENGTH REQUIREMENTS - FLAPS 30**  
*MODEL 787-8 (ROLLS-ROYCE ENGINES)*

# PRELIMINARY INFORMATION

DATA TO BE PROVIDED  
AT A LATER DATE

For more information about the data on this page please contact us at:

e-mail: [AirportTechnology@boeing.com](mailto:AirportTechnology@boeing.com)

OR

Fax: 425-237-8281

**3.4.4 F.A.R. LANDING RUNWAY LENGTH REQUIREMENTS - FLAPS 25**  
*MODEL 787-8 (ROLLS-ROYCE ENGINES)*



# PRELIMINARY INFORMATION

## **4.0 GROUND MANEUVERING**

### **4.1 General Information**

### **4.2 Turning Radii**

### **4.3 Clearance Radii**

### **4.4 Visibility From Cockpit in Static Position**

### **4.5 Runway and Taxiway Turn Paths**

### **4.6 Runway Holding Bay**

# PRELIMINARY INFORMATION

## 4.0 GROUND MANEUVERING

### 4.1 General Information

This section provides airplane turning capability and maneuvering characteristics.

For ease of presentation, these data have been determined from the theoretical limits imposed by the geometry of the aircraft, and where noted, provide for a normal allowance for tire slippage. As such, they reflect the turning capability of the aircraft in favorable operating circumstances. These data should be used only as guidelines for the method of determination of such parameters and for the maneuvering characteristics of this aircraft.

In the ground operating mode, varying airline practices may demand that more conservative turning procedures be adopted to avoid excessive tire wear and reduce possible maintenance problems. Airline operating procedures will vary in the level of performance over a wide range of operating circumstances throughout the world. Variations from standard aircraft operating patterns may be necessary to satisfy physical constraints within the maneuvering area, such as adverse grades, limited area, or high risk of jet blast damage. For these reasons, ground maneuvering requirements should be coordinated with the using airlines prior to layout planning.

Section 4.2 shows turning radii for various nose gear steering angles. Radii for the main and nose gears are measured from the turn center to the outside of the tire.

Section 4.3 provides data on minimum width of pavement required for 180° turn.

Section 4.4 shows the pilot's visibility from the cockpit and the limits of ambinocular vision through the windows. Ambinocular vision is defined as the total field of vision seen simultaneously by both eyes.

Section 4.5 shows approximate wheel paths of a 787 on runway to taxiway, and taxiway to taxiway turns.

Section 4.6 illustrates a typical runway holding bay configuration.

# PRELIMINARY INFORMATION

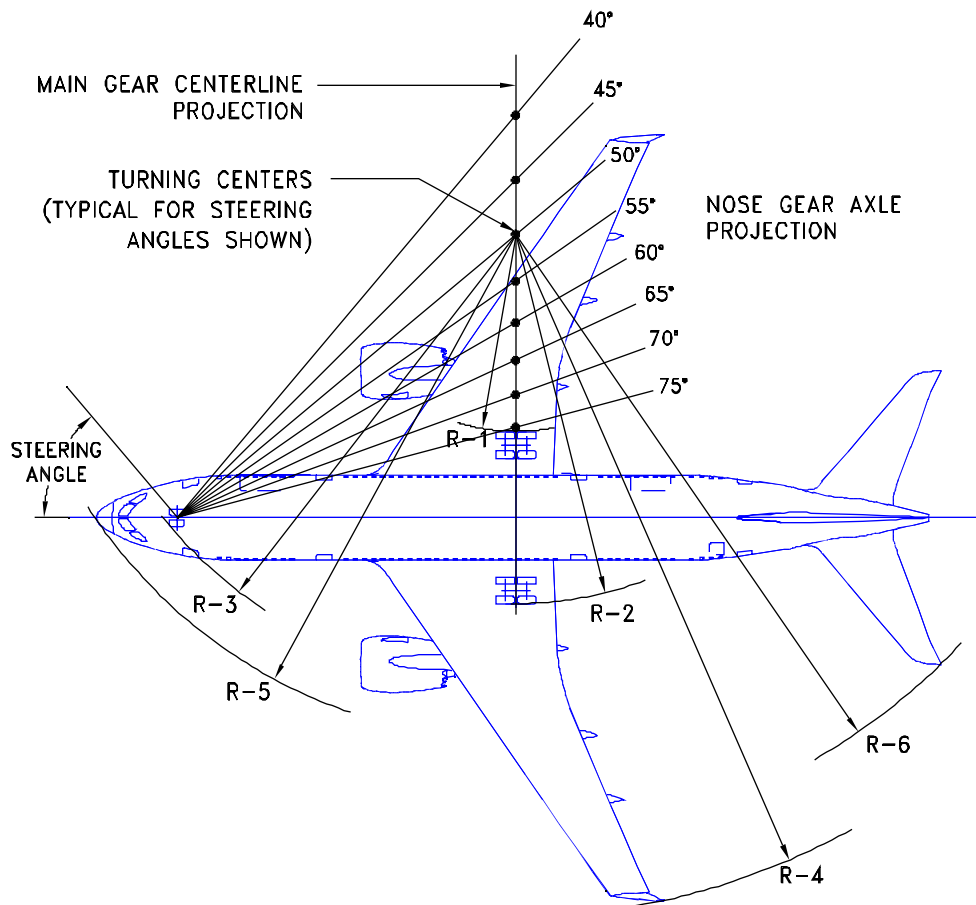

NOTES: \* ACTUAL OPERATING TURNING RADII MAY BE GREATER THAN SHOWN.  
 \* CONSULT WITH AIRLINE FOR SPECIFIC OPERATING PROCEDURE

STEERING ANGLE (DEG)	R-1		R-2		R-3		R-4		R-5		R-6	
	INNER GEAR		OUTER GEAR		NOSE GEAR		WING TIP		NOSE		TAIL	
	FT	M	FT	M	FT	M	FT	M	FT	M	FT	M
30	110.5	33.7	148.6	45.3	151.4	46.2	231.6	70.6	160.1	48.5	187.1	57.0
35	87.7	26.7	125.8	38.4	132.2	40.3	209.2	63.8	142.0	43.1	167.8	51.1
40	70.1	21.4	108.2	33.0	118.2	36.0	191.9	58.5	129.0	39.1	153.4	46.8
45	55.7	17.0	93.8	28.6	107.6	32.8	177.9	54.2	119.4	36.3	142.3	43.4
50	43.7	13.3	81.8	24.9	99.5	30.3	166.2	50.7	112.1	34.1	133.5	40.7
55	33.3	10.2	71.4	21.8	93.2	28.4	156.1	47.6	106.5	32.4	126.3	38.5
60	24.1	7.4	62.2	19.0	88.2	26.9	147.3	44.9	102.2	31.1	120.3	36.7
65	15.8	4.8	53.9	16.4	84.4	25.7	139.3	42.5	99.0	30.1	115.3	35.1
70	8.2	2.5	46.3	14.1	81.5	24.8	132.0	40.2	96.5	29.4	111.0	33.8

## 4.2.1 TURNING RADII - NO SLIP ANGLE MODEL 787-8

D6-58333

# PRELIMINARY INFORMATION

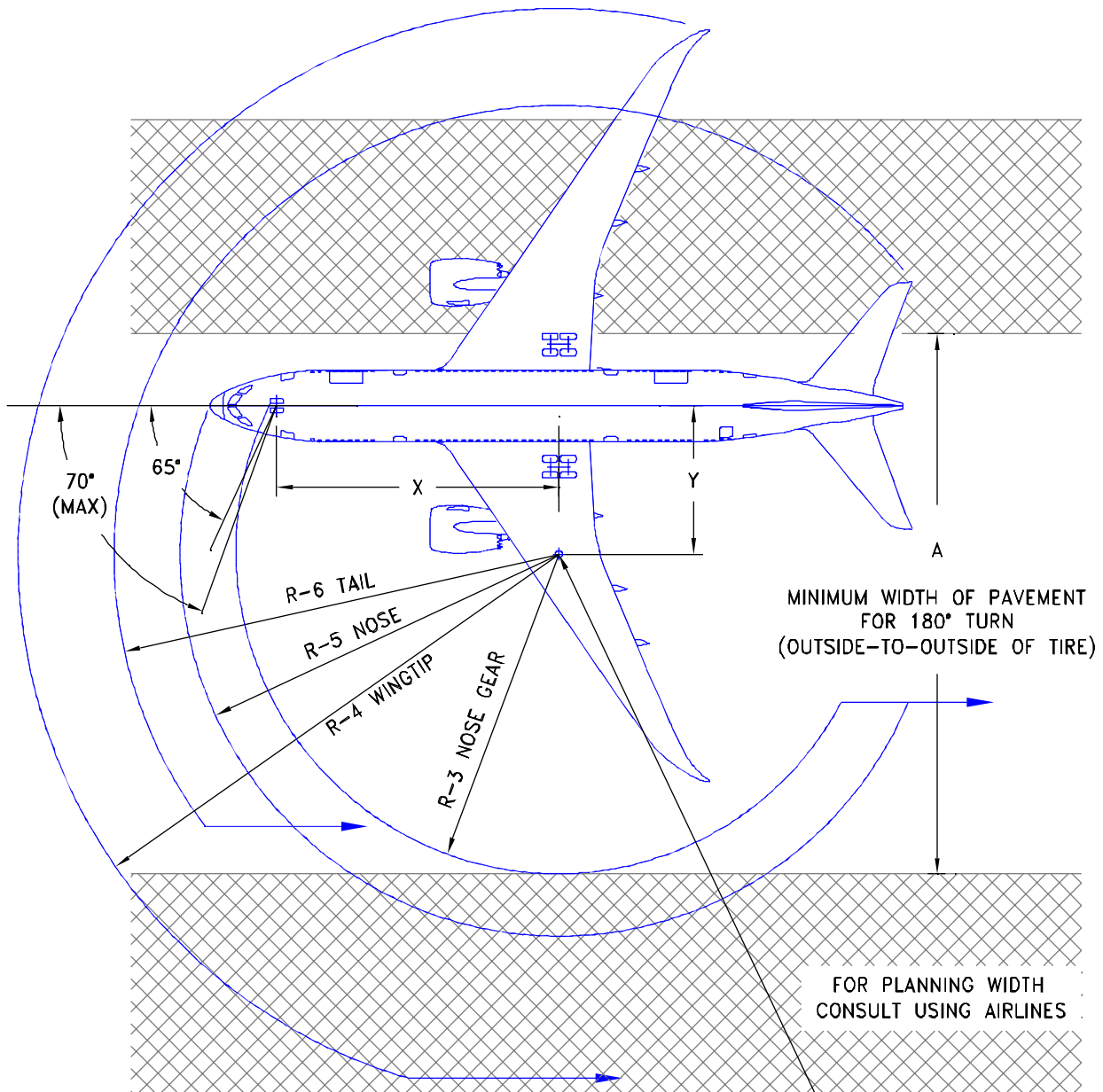

THEORETICAL CENTER OF TURN FOR MINIMUM TURNING RADIUS —  
 SLOW CONTINUOUS TURNING AT MINIMUM THRUST  
 ON ALL ENGINES. NO DIFFERENTIAL BRAKING.  
 CONSULT USING AIRLINE FOR SPECIFIC OPERATING PROCEDURES.

MODEL	EFFECTIVE STEERING ANGLE (DEG)	X		Y		A		R3		R4		R5		R6	
		FT	M	FT	M	FT	M	FT	M	FT	M	FT	M	FT	M
787-8	65	74.8	22.8	34.9	10.6	138.4	42.2	84.7	25.7	139.3	42.5	99.0	30.1	115.3	35.1

### 4.3 CLEARANCE RADII MODEL 787-8

# PRELIMINARY INFORMATION

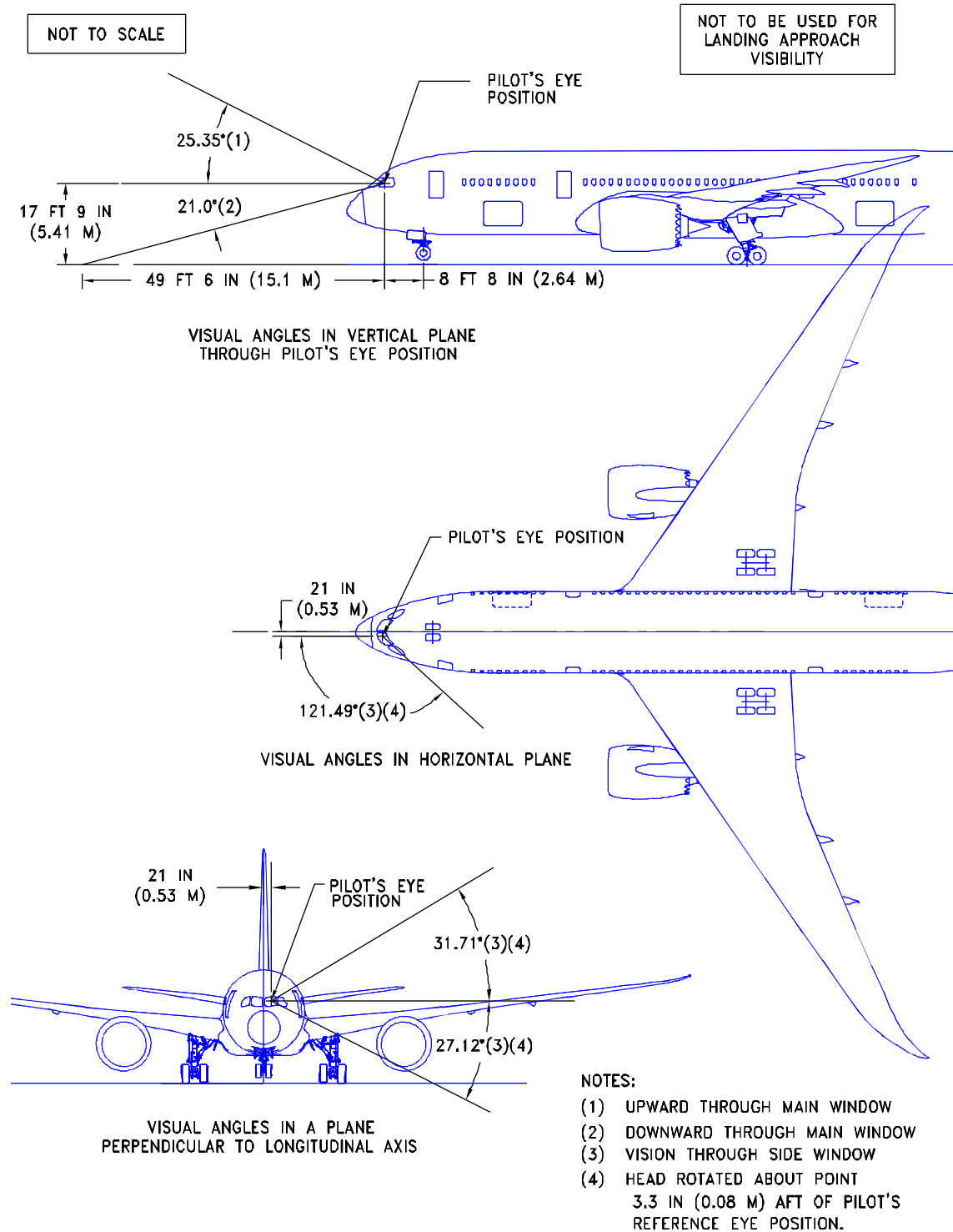

## 4.4 VISIBILITY FROM COCKPIT IN STATIC POSITION

MODEL 787-8

# PRELIMINARY INFORMATION

## NOTE

BEFORE DETERMINING THE SIZE OF THE INTERSECTION FILLET, CHECK WITH THE AIRLINES REGARDING THE OPERATING PROCEDURES THAT THEY USE AND THE AIRCRAFT TYPES THAT ARE EXPECTED TO SERVE THE AIRPORT

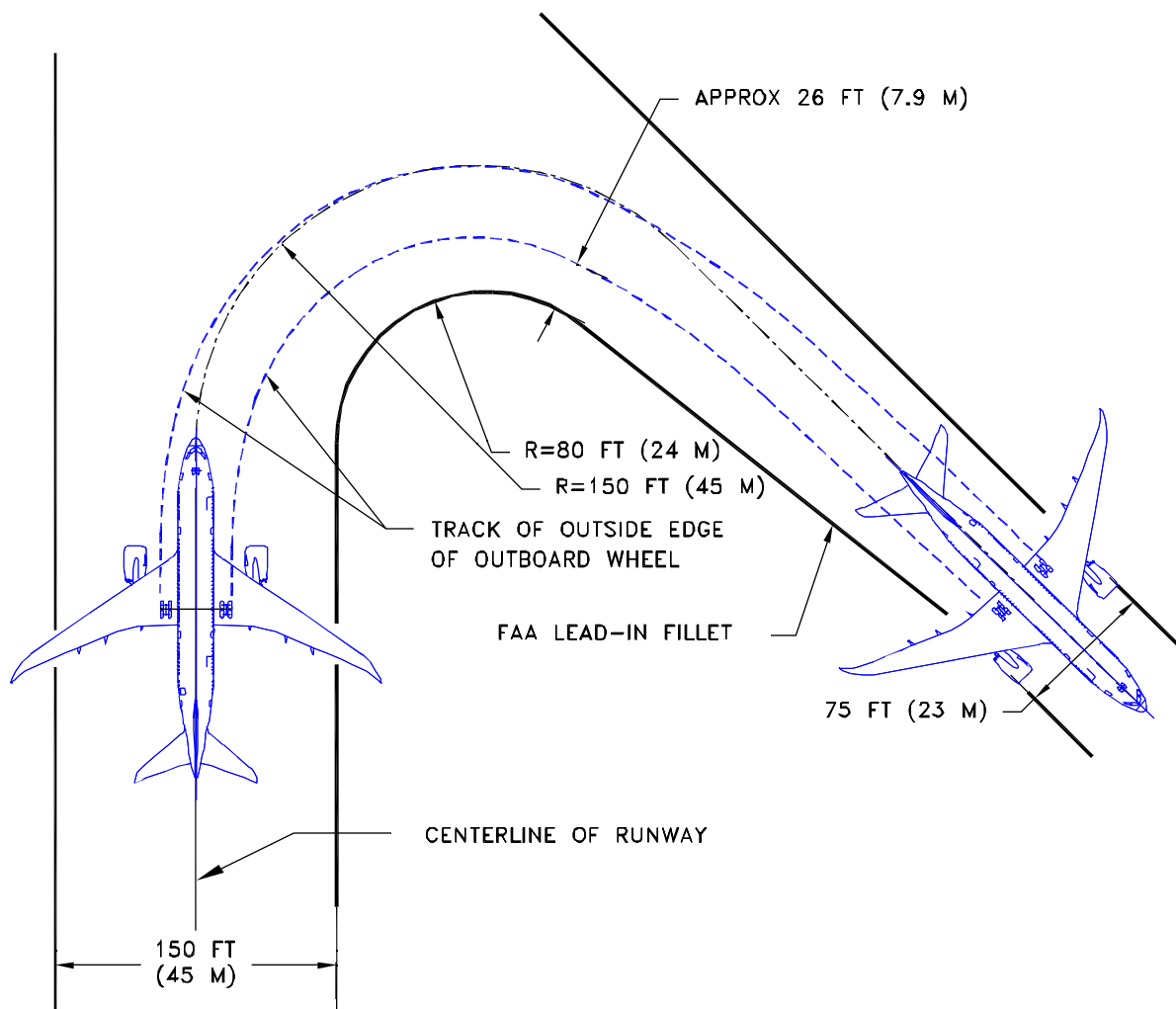

NOSE GEAR TRACKS  
CENTERLINE OF TURNS

### 4.5.1 RUNWAY AND TAXIWAY TURNPATHS - RUNWAY-TO-TAXIWAY, MORE THAN 90-DEGREE TURN

MODEL 787-8

# PRELIMINARY INFORMATION

## NOTE

BEFORE DETERMINING THE SIZE OF THE INTERSECTION FILLET, CHECK WITH THE AIRLINES REGARDING THE OPERATING PROCEDURES THAT THEY USE AND THE AIRCRAFT TYPES THAT ARE EXPECTED TO SERVE THE AIRPORT

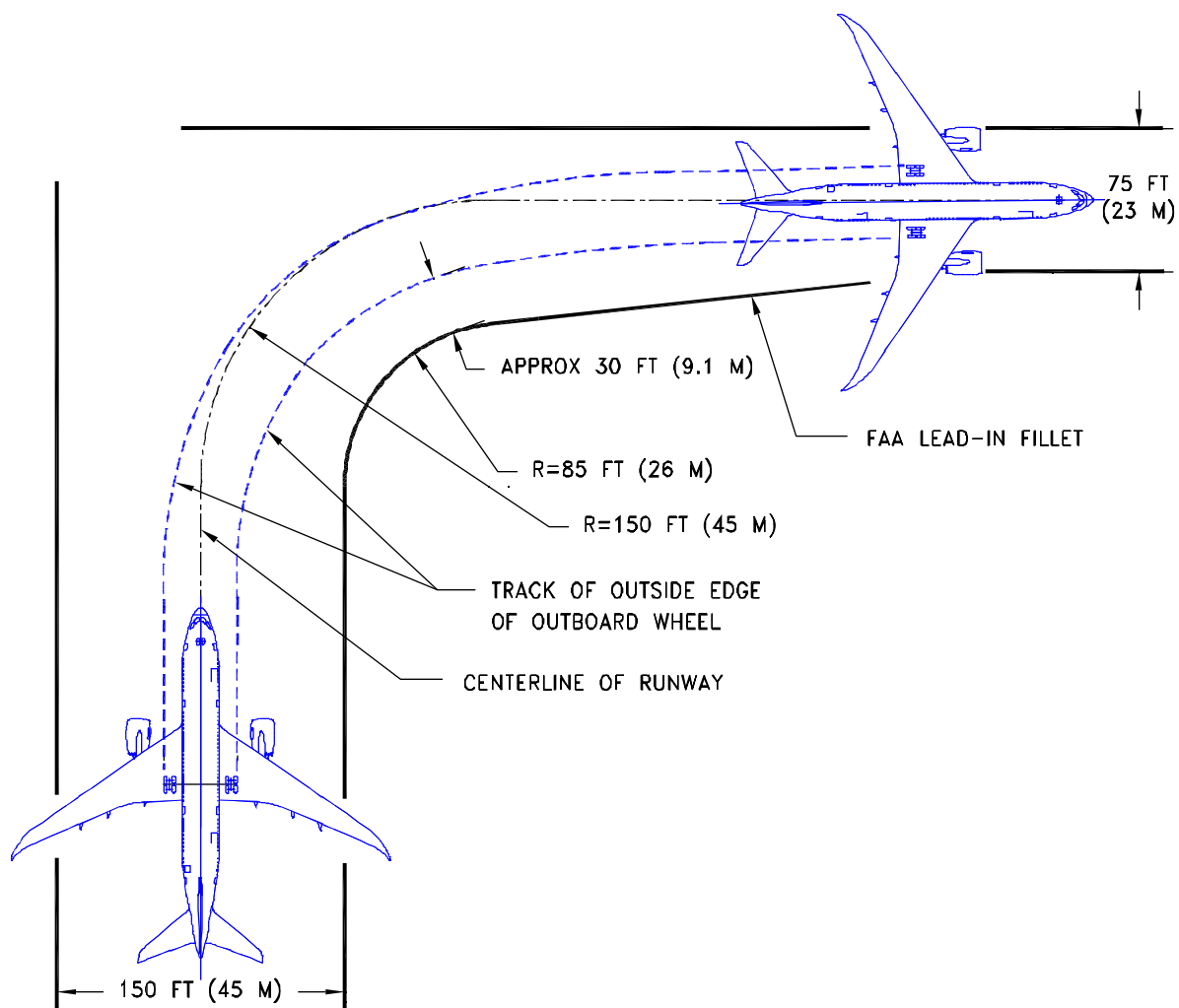

NOSE GEAR TRACKS  
CENTERLINE OF TURNS

## 4.5.2 RUNWAY AND TAXIWAY TURNPATHS - RUNWAY-TO-TAXIWAY, 90-DEGREE TURN MODEL 787-8

# PRELIMINARY INFORMATION

## NOTE

BEFORE DETERMINING THE SIZE OF THE INTERSECTION FILLET, CHECK WITH THE AIRLINES REGARDING THE OPERATING PROCEDURES THAT THEY USE AND THE AIRCRAFT TYPES THAT ARE EXPECTED TO SERVE THE AIRPORT

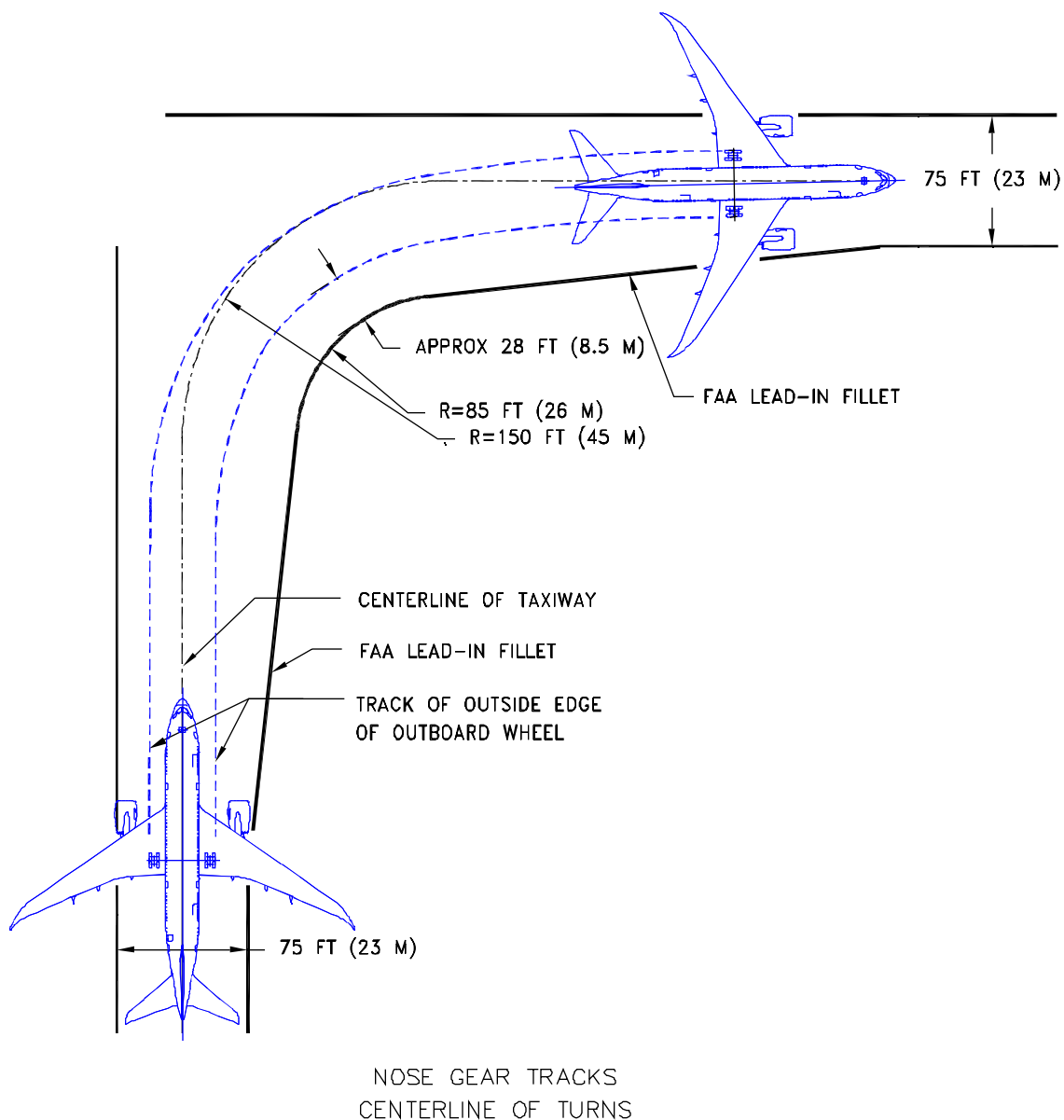

### 4.5.3 RUNWAY AND TAXIWAY TURNPATHS - TAXIWAY-TO-TAXIWAY, 90-DEGREE TURN, NOSE GEAR TRACKS CENTERLINE *MODEL 787-8*



# PRELIMINARY INFORMATION

## NOTE

BEFORE DETERMINING THE SIZE OF THE INTERSECTION FILLET, CHECK WITH THE AIRLINES REGARDING THE OPERATING PROCEDURES THAT THEY USE AND THE AIRCRAFT TYPES THAT ARE EXPECTED TO SERVE THE AIRPORT

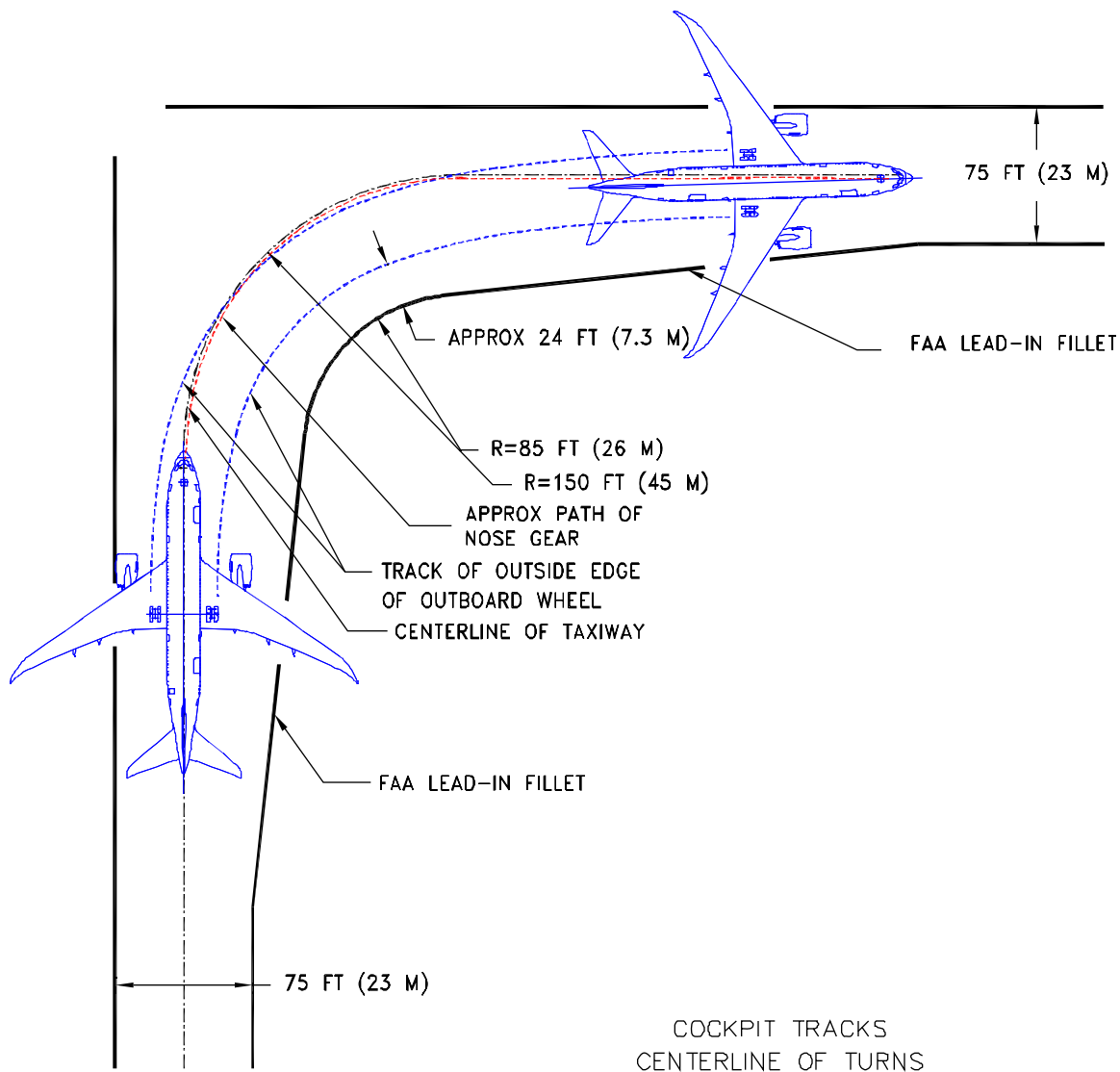

### 4.5.4 RUNWAY AND TAXIWAY TURNPATHS - TAXIWAY-TO-TAXIWAY, 90-DEGREE TURN, COCKPIT TRACKS CENTERLINE MODEL 787-8

# PRELIMINARY INFORMATION

## NOTE

BEFORE DETERMINING THE SIZE OF THE INTERSECTION FILLET, CHECK WITH THE AIRLINES REGARDING THE OPERATING PROCEDURES THAT THEY USE AND THE AIRCRAFT TYPES THAT ARE EXPECTED TO SERVE THE AIRPORT

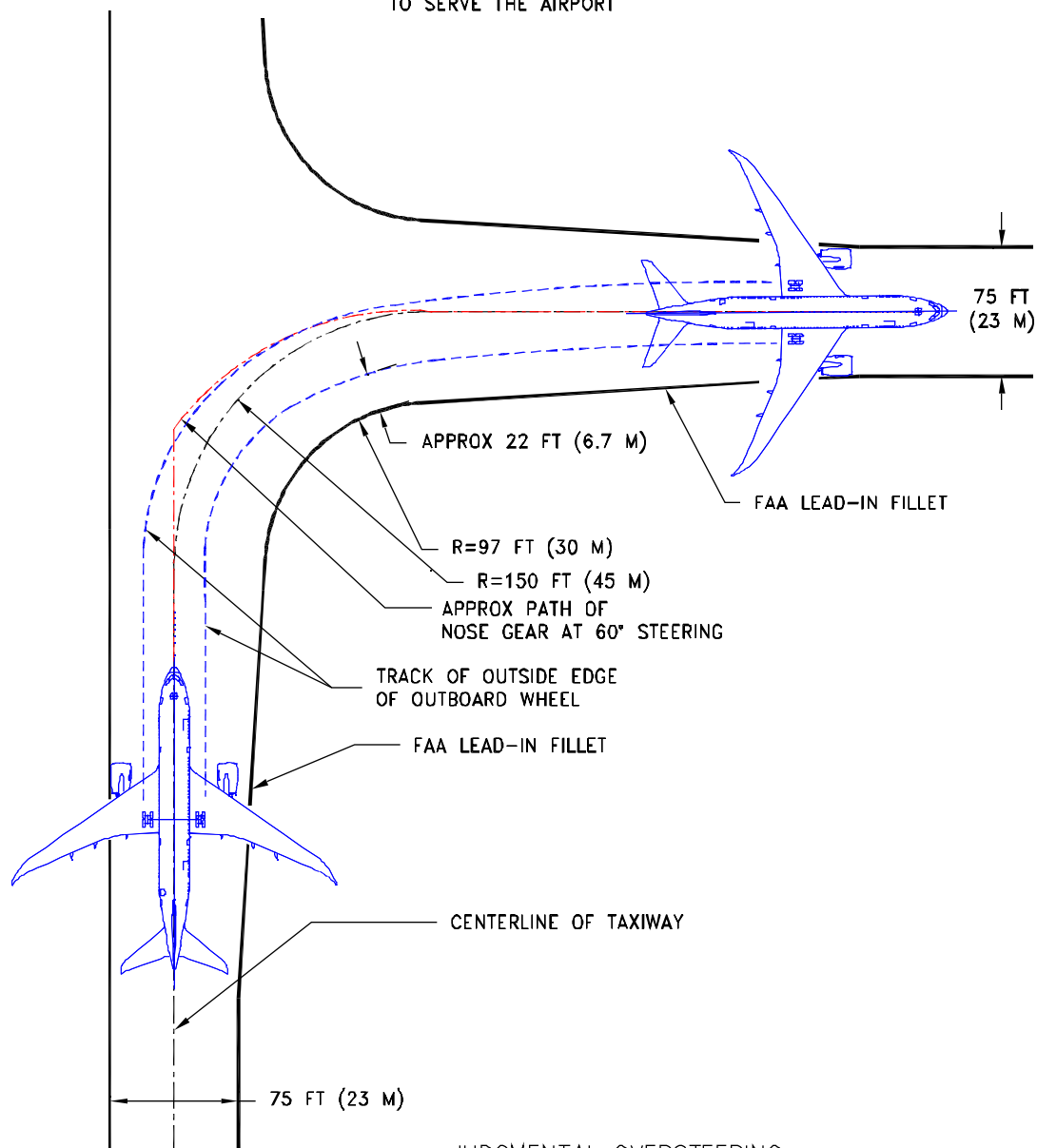

JUDGMENTAL OVERSTEERING  
NOSE GEAR TRACKING BEYOND  
CENTERLINE OF TURNS

## 4.5.5 RUNWAY AND TAXIWAY TURNPATHS - TAXIWAY-TO-TAXIWAY, 90-DEGREE TURN, JUDGMENTAL OVERSTEERING MODEL 787-8

# PRELIMINARY INFORMATION

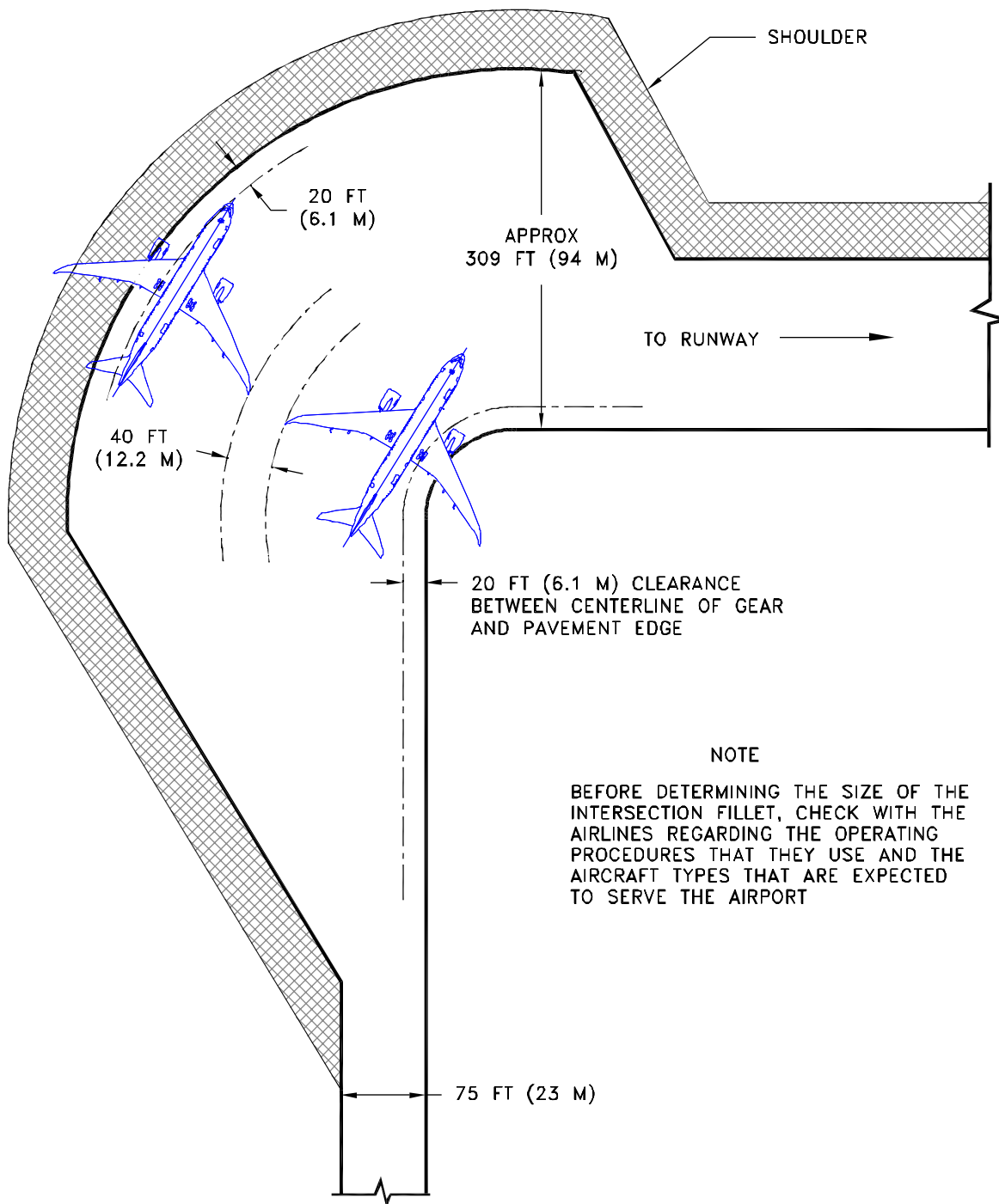

## 4.6 RUNWAY HOLDING BAY MODEL 787-8

# PRELIMINARY INFORMATION

THIS PAGE INTENTIONALLY LEFT BLANK

# PRELIMINARY INFORMATION

## **5.0 TERMINAL SERVICING**

**5.1 Airplane Servicing Arrangement - Typical Turnaround**

**5.2 Terminal Operations - Turnaround Station**

**5.3 Terminal Operations - En Route Station**

**5.4 Ground Servicing Connections and Capacities**

**5.5 Engine Start and Ground Power Requirements**

**5.6 Conditioned Air Flow Requirements**

**5.7 Ground Towing Requirements**

# PRELIMINARY INFORMATION

## 5.0 TERMINAL SERVICING

During turnaround at the terminal, certain services must be performed on the aircraft, usually within a given time, to meet flight schedules. This section shows service vehicle arrangements, schedules, locations of service points, and typical service requirements. The data presented in this section reflect ideal conditions for a single airplane. Service requirements may vary according to airplane condition and airline procedure.

Section 5.1 shows typical arrangements of ground support equipment during turnaround. The 787 aircraft does not have a pneumatic system onboard. In case of an inoperable auxiliary power unit (APU), engine starts may be accomplished via the aircraft body electrical connections. Passenger loading bridges or portable passenger stairs could be used to load or unload passengers.

Sections 5.2 and 5.3 show typical service times at the terminal. These charts give typical schedules for performing service on the airplane within a given time. Service times could be rearranged to suit availability of personnel, airplane configuration, and degree of service required.

Section 5.4 shows the locations of ground service connections in both graphic and tabular formats. Typical capacities and service requirements are shown in the tables. Services with requirements that vary with conditions are described in subsequent sections.

Section 5.5 shows minimum electrical engine start and ground power requirements.

Section 5.6 shows conditioned air flow requirements for heating and cooling using ground conditioned air. Air conditioning requirements are also shown for heating and cooling to maintain a constant cabin air temperature using low pressure conditioned air.

Section 5.7 shows ground towing requirements for various ground surface conditions.

# PRELIMINARY INFORMATION

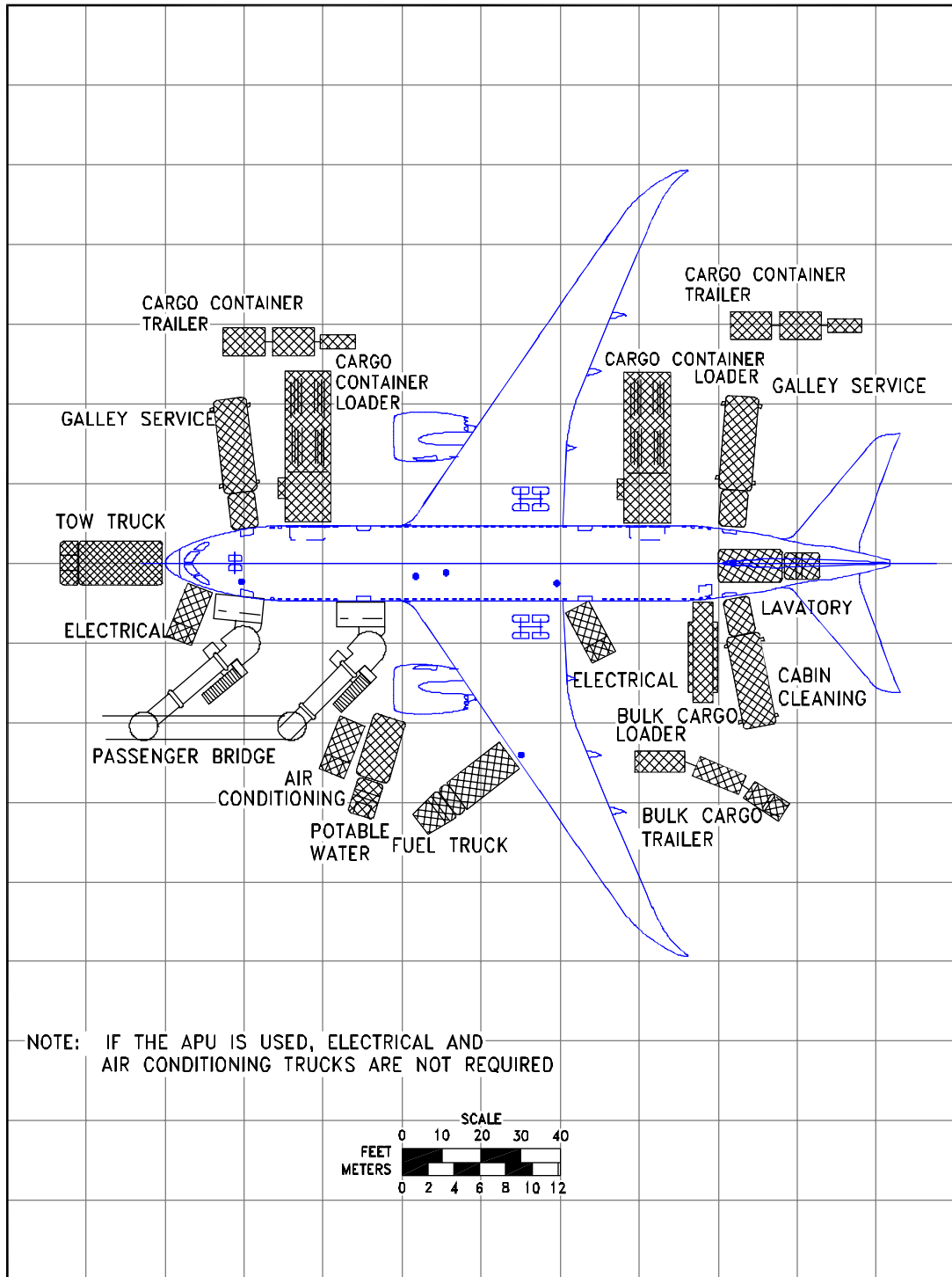

## 5.1.1 AIRPLANE SERVICING ARRANGEMENT - TYPICAL TURNAROUND

MODEL 787-8

# PRELIMINARY INFORMATION

DATA TO BE PROVIDED  
AT A LATER DATE

For more information about the data on this page please contact us at:

e-mail: [AirportTechnology@boeing.com](mailto:AirportTechnology@boeing.com)

OR

Fax: 425-237-8281

## 5.2.1 TERMINAL OPERATIONS - TURNAROUND STATION

*MODEL 787-8*



# PRELIMINARY INFORMATION

DATA TO BE PROVIDED  
AT A LATER DATE

For more information about the data on this page please contact us at:

e-mail: [AirportTechnology@boeing.com](mailto:AirportTechnology@boeing.com)

OR

Fax: 425-237-8281

## **5.3.1 TERMINAL OPERATIONS - EN ROUTE STATION**

*MODEL 787-8*

# PRELIMINARY INFORMATION

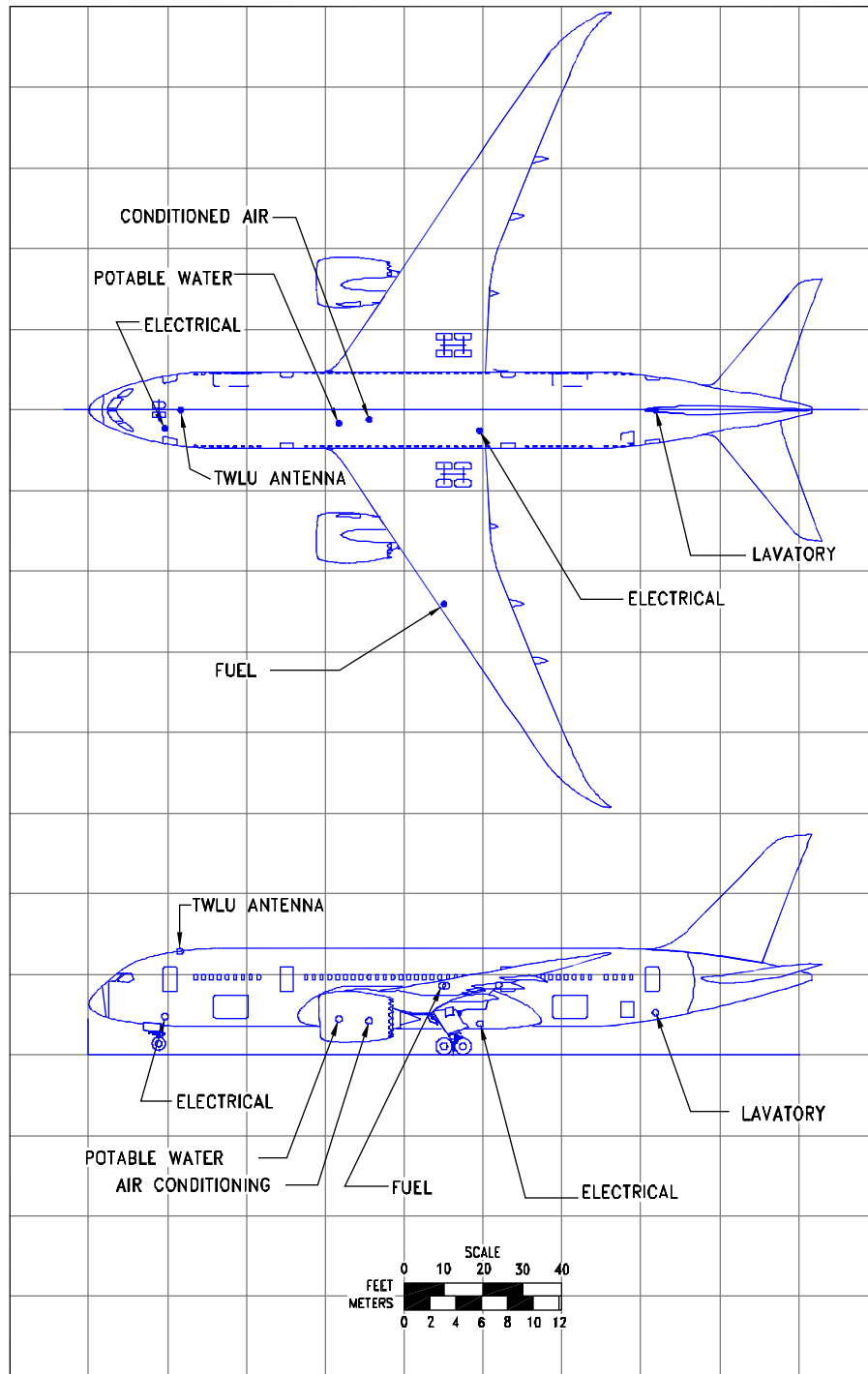

## 5.4.1 GROUND SERVICING CONNECTIONS *MODEL 787-8*

# PRELIMINARY INFORMATION

SYSTEM	MODEL	DISTANCE AFT OF NOSE		DISTANCE FROM AIRPLANE CENTERLINE				MAX HT ABOVE GROUND	
				LH SIDE		RH SIDE			
		FT	M	FT	M	FT	M	FT	M
CONDITIONED AIR ONE 8-IN (20.3 CM) PORT	787-8	71	21.6	2.4	0.7	-	-	6.6	2.0
ELECTRICAL TWO FORWARD GROUND POWER RECEPTACLES ONE MID-AFT GROUND POWER RECEPTACLE ALL RECEPTACLES ARE 90 KVA , 200/115 V AC 400 HZ,	787-8	19.5	5.9	4.8	1.5	-	-	8	2.4
		99.4	30.3	5.3	1.6	-	-	7	2.1
TWLU ANTENNA LOCATION IS ON THE CENTERLINE	787-8	23.4	7.1	-	-	-	-	-	-
POTABLE WATER ONE SERVICE CONNECTION	787-8	63	19.2	3	0.9	-	-	6	1.8
FUEL ONE UNDERWING PRESSURE CONNECTOR WITH TWO FUELING PORTS  TOTAL CAPACITY 33,528 US GAL (126,917 LITERS)	787-8	90	27.4	48	14.6	-	-	17	5.2
LAVATORY BOTH FORWARD AND AFT TOILETS ARE SERVICED THROUGH ONE SERVICE PANEL	787-8	144	43.9	0	0	0	0	9.5	2.9

## 5.4.2 GROUND SERVICING CONNECTIONS AND CAPACITIES

*MODEL 787-8*

# PRELIMINARY INFORMATION

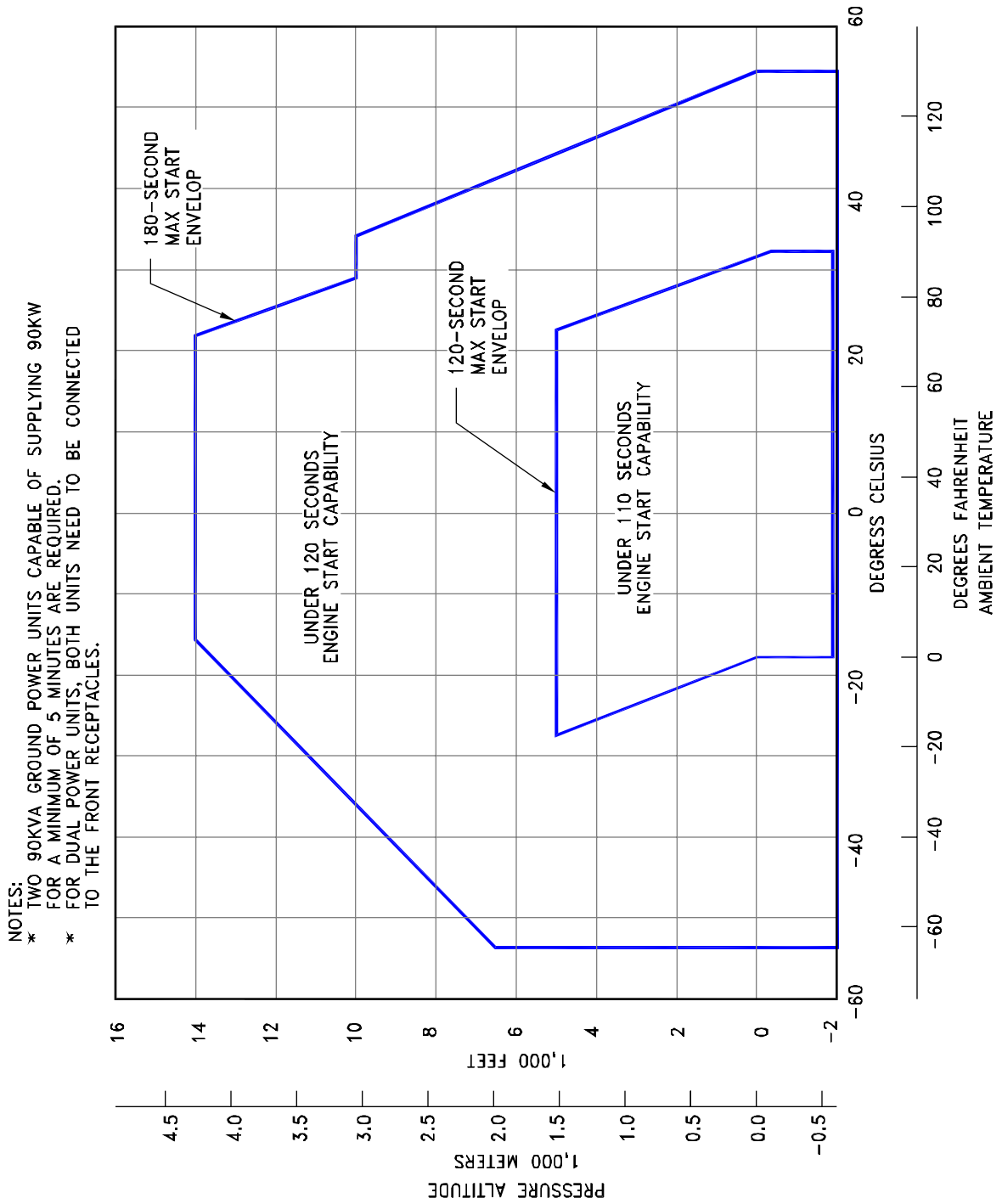

## 5.5.1 ENGINE START AND GROUND POWER REQUIREMENTS - ELECTRICAL MODEL 787-8

# PRELIMINARY INFORMATION

## **THIS PAGE LEFT BLANK ON PURPOSE**

The 787 aircraft is an entirely electrical aircraft and will not have a pneumatic system onboard. In case of an inoperable APU, engine starts may be accomplished via the aircraft electrical connection.

For more information about the data on this page please contact us at:

e-mail: [AirportTechnology@boeing.com](mailto:AirportTechnology@boeing.com)

OR

Fax: 425-237-8281

## **5.5.2 ENGINE START AND GROUND POWER REQUIREMENTS - PNEUMATIC** *MODEL 787-8*

# PRELIMINARY INFORMATION

DATA TO BE PROVIDED  
AT A LATER DATE

For more information about the data on this page please contact us at:

e-mail: [AirportTechnology@boeing.com](mailto:AirportTechnology@boeing.com)

OR

Fax: 425-237-8281

## **5.6.1 CONDITIONED AIR FLOW REQUIREMENTS - HEATING**

*MODEL 787-8*

# PRELIMINARY INFORMATION

DATA TO BE PROVIDED  
AT A LATER DATE

For more information about the data on this page please contact us at:

e-mail: [AirportTechnology@boeing.com](mailto:AirportTechnology@boeing.com)

OR

Fax: 425-237-8281

## **5.6.2 CONDITIONED AIR FLOW REQUIREMENTS - COOLING**

*MODEL 787-8*

# PRELIMINARY INFORMATION

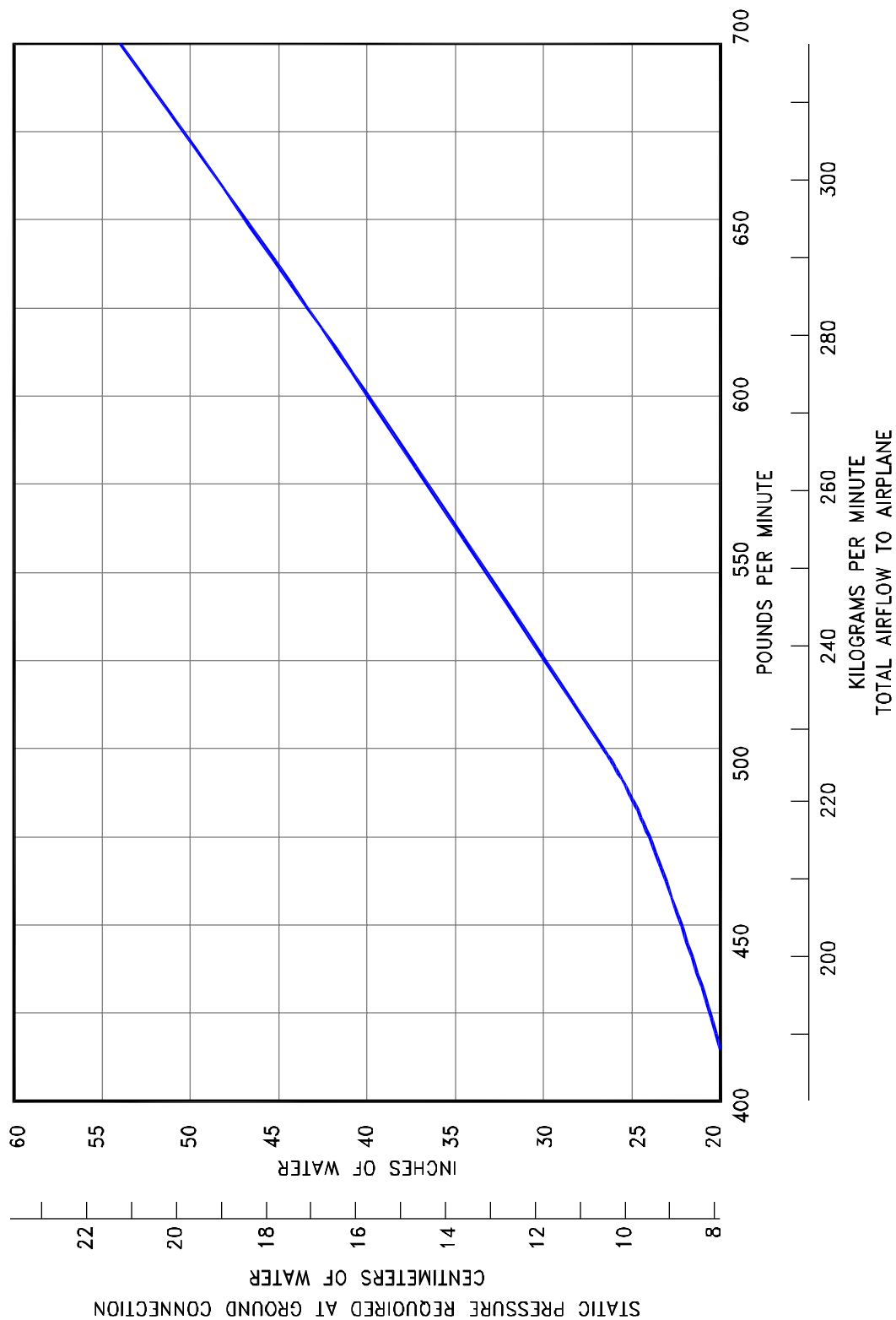

## 5.6.3 CONDITIONED AIR FLOW REQUIREMENTS – STEADY STATE MODEL 787-8



# PRELIMINARY INFORMATION

DATA TO BE PROVIDED  
AT A LATER DATE

For more information about the data on this page please contact us at:

e-mail: [AirportTechnology@boeing.com](mailto:AirportTechnology@boeing.com)

OR

Fax: 425-237-8281

## **5.7.1 GROUND TOWING REQUIREMENTS - ENGLISH UNITS**

*MODEL 787-8*

# PRELIMINARY INFORMATION

DATA TO BE PROVIDED  
AT A LATER DATE

For more information about the data on this page please contact us at:

e-mail: [AirportTechnology@boeing.com](mailto:AirportTechnology@boeing.com)

OR

Fax: 425-237-8281

## **5.7.2 GROUND TOWING REQUIREMENTS - METRIC UNITS**

*MODEL 787-8*

# PRELIMINARY INFORMATION

## **6.0 JET ENGINE WAKE AND NOISE DATA**

### **6.1 Jet Engine Exhaust Velocities and Temperatures**

### **6.2 Airport and Community Noise**

# PRELIMINARY INFORMATION

## **6.0 JET ENGINE WAKE AND NOISE DATA**

### **6.1 Jet Engine Exhaust Velocities and Temperatures**

This section shows exhaust velocity and temperature contours aft of the 787-8 airplane. The contours were calculated from a standard computer analysis using three-dimensional viscous flow equations with mixing of primary, fan, and free-stream flow. The presence of the ground plane is included in the calculations as well as engine tilt and toe-in. Mixing of flows from the engines is also calculated. The analysis does not include thermal buoyancy effects which tend to elevate the jet wake above the ground plane. The buoyancy effects are considered to be small relative to the exhaust velocity and therefore are not included.

The graphs show jet wake velocity and temperature contours for representative engines. The results are valid for sea level, static, standard day conditions. The effect of wind on jet wakes is not included. There is evidence to show that a downwind or an upwind component does not simply add or subtract from the jet wake velocity, but rather carries the whole envelope in the direction of the wind. Crosswinds may carry the jet wake contour far to the side at large distances behind the airplane.

# PRELIMINARY INFORMATION

DATA TO BE PROVIDED  
AT A LATER DATE

For more information about the data on this page please contact us at:

e-mail: [AirportTechnology@boeing.com](mailto:AirportTechnology@boeing.com)

OR

Fax: 425-237-8281

## **6.1.1 PREDICTED JET ENGINE EXHAUST VELOCITY CONTOURS - IDLE THRUST**

*MODEL 787-8*

# PRELIMINARY INFORMATION

DATA TO BE PROVIDED  
AT A LATER DATE

For more information about the data on this page please contact us at:

e-mail: [AirportTechnology@boeing.com](mailto:AirportTechnology@boeing.com)

OR

Fax: 425-237-8281

**6.1.2 PREDICTED JET ENGINE EXHAUST VELOCITY CONTOURS - BREAKAWAY THRUST**  
*MODEL 787-8*

# PRELIMINARY INFORMATION

DATA TO BE PROVIDED  
AT A LATER DATE

For more information about the data on this page please contact us at:

e-mail: [AirportTechnology@boeing.com](mailto:AirportTechnology@boeing.com)

OR

Fax: 425-237-8281

**6.1.3 PREDICTED JET ENGINE EXHAUST VELOCITY CONTOURS - TAKEOFF THRUST**  
*MODEL 787-8*

# PRELIMINARY INFORMATION

DATA TO BE PROVIDED  
AT A LATER DATE

For more information about the data on this page please contact us at:

e-mail: [AirportTechnology@boeing.com](mailto:AirportTechnology@boeing.com)

OR

Fax: 425-237-8281

**6.1.4 PREDICTED JET ENGINE EXHAUST TEMPERATURE CONTOURS - IDLE THRUST**  
*MODEL 787-8*



# PRELIMINARY INFORMATION

DATA TO BE PROVIDED  
AT A LATER DATE

For more information about the data on this page please contact us at:

e-mail: [AirportTechnology@boeing.com](mailto:AirportTechnology@boeing.com)

OR

Fax: 425-237-8281

**6.1.5 PREDICTED JET ENGINE EXHAUST TEMPERATURE CONTOURS - BREAKAWAY  
THRUST**  
*MODEL 787-8*

# PRELIMINARY INFORMATION

DATA TO BE PROVIDED  
AT A LATER DATE

For more information about the data on this page please contact us at:

e-mail: [AirportTechnology@boeing.com](mailto:AirportTechnology@boeing.com)

OR

Fax: 425-237-8281

**6.1.6 PREDICTED JET ENGINE EXHAUST TEMPERATURE CONTOURS - TAKEOFF THRUST**  
*MODEL 787-8*

# PRELIMINARY INFORMATION

## **7.0 PAVEMENT DATA**

### **7.1 General Information**

### **7.2 Landing Gear Footprint**

### **7.3 Maximum Pavement Loads**

### **7.4 Landing Gear Loading on Pavement**

### **7.5 Flexible Pavement Requirements - U.S. Army Corps of Engineers Method S-77-1**

### **7.6 Flexible Pavement Requirements - LCN Conversion**

### **7.7 Rigid Pavement Requirements - Portland Cement Association Design Method**

### **7.8 Rigid Pavement Requirements - LCN Conversion**

### **7.9 Rigid Pavement Requirements - FAA Method**

### **7.10 ACN/PCN Reporting System - Flexible and Rigid Pavements**

# PRELIMINARY INFORMATION

## 7.0 PAVEMENT DATA

### 7.1 General Information

A brief description of the pavement charts that follow will help in their use for airport planning. Each airplane configuration is depicted with a minimum range of six loads imposed on the main landing gear to aid in interpolation between the discrete values shown. All curves for any single chart represent data based on rated loads and tire pressures considered normal and acceptable by current aircraft tire manufacturer's standards. Tire pressures, where specifically designated on tables and charts, are at values obtained under loaded conditions as certificated for commercial use.

Section 7.2 presents basic data on the landing gear footprint configuration, maximum design taxi loads, and tire sizes and pressures.

Maximum pavement loads for certain critical conditions at the tire-to-ground interface are shown in Section 7.3, with the tires having equal loads on the struts.

Pavement requirements for commercial airplanes are customarily derived from the static analysis of loads imposed on the main landing gear struts. The chart in Section 7.4 is provided in order to determine these loads throughout the stability limits of the airplane at rest on the pavement. These main landing gear loads are used as the point of entry to the pavement design charts, interpolating load values where necessary.

The flexible pavement design curves (Section 7.5) are based on procedures set forth in Instruction Report No. S-77-1, "Procedures for Development of CBR Design Curves," dated June 1977, and as modified according to the methods described in ICAO Aerodrome Design Manual, Part 3, Pavements, 2<sup>nd</sup> Edition, 1983, Section 1.1 (The ACN-PCN Method), and utilizing the alpha factors approved by ICAO in October 2007. Instruction Report No. S-77-1 was prepared by the U.S. Army Corps of Engineers Waterways Experiment Station, Soils and Pavements Laboratory, Vicksburg, Mississippi. The line showing 10,000 coverages is used to calculate Aircraft Classification Number (ACN).

The following procedure is used to develop the curves, such as shown in Section 7.5:

1. Having established the scale for pavement depth at the bottom and the scale for CBR at the top, an arbitrary line is drawn representing 6,000 annual departures.
2. Values of the aircraft gross weight are then plotted.

# PRELIMINARY INFORMATION

3. Additional annual departure lines are drawn based on the load lines of the aircraft gross weights already established.
4. An additional line representing 10,000 coverages (used to calculate the flexible pavement Aircraft Classification Number) is also placed.

All Load Classification Number (LCN) curves (Sections 7.6 and 7.8) have been developed from a computer program based on data provided in International Civil Aviation Organization (ICAO) document 9157-AN/901, Aerodrome Design Manual, Part 3, "Pavements", First Edition, 1977. LCN values are shown directly for parameters of weight on main landing gear, tire pressure, and radius of relative stiffness ( $t$ ) for rigid pavement or pavement thickness or depth factor ( $h$ ) for flexible pavement.

Rigid pavement design curves (Section 7.7) have been prepared with the Westergaard equation in general accordance with the procedures outlined in the Design of Concrete Airport Pavement (1955 edition) by Robert G. Packard, published by the American Concrete Pavement Association, 3800 North Wilke Road, Arlington Heights, Illinois 60004-1268. These curves are modified to the format described in the Portland Cement Association publication XP6705-2, Computer Program for Airport Pavement Design (Program PDILB), 1968, by Robert G. Packard.

The following procedure is used to develop the rigid pavement design curves shown in Section 7.7:

1. Having established the scale for pavement thickness to the left and the scale for allowable working stress to the right, an arbitrary load line is drawn representing the main landing gear maximum weight to be shown.
2. Values of the subgrade modulus ( $k$ ) are then plotted.
3. Additional load lines for the incremental values of weight on the main landing gear are drawn on the basis of the curve for  $k = 300$ , already established.

The rigid pavement design curves (Section 7.9) have been developed based on methods used in the FAA Advisory Circular AC 150/5320-6D July 7, 1995. The following procedure is used to develop the curves, such as shown in Section 7.9:

1. Having established the scale for pavement flexure strength on the left and temporary scale for pavement thickness on the right, an arbitrary load line is drawn representing the main landing gear maximum weight to be shown at 5,000 coverages.

# PRELIMINARY INFORMATION

2. Values of the subgrade modulus (k) are then plotted.
3. Additional load lines for the incremental values of weight are then drawn on the basis of the subgrade modulus curves already established.
4. The permanent scale for the rigid-pavement thickness is then placed. Lines for other than 5,000 coverages are established based on the aircraft pass-to-coverage ratio.

The ACN/PCN system (Section 7.10) as referenced in ICAO Annex 14, “Aerodromes, Fourth Edition, July 2004, provides a standardized international airplane/pavement rating system replacing the various S, T, TT, LCN, AUW, ISWL, etc., rating systems used throughout the world. ACN is the Aircraft Classification Number and PCN is the Pavement Classification Number. An aircraft having an ACN equal to or less than the PCN can operate on the pavement subject to any limitation on the tire pressure. Numerically, the ACN is two times the derived single-wheel load expressed in thousands of kilograms, where the derived single wheel load is defined as the load on a single tire inflated to 181 psi (1.25 MPa) that would have the same pavement requirements as the aircraft. Computationally, the ACN/PCN system uses the PCA program PDILB for rigid pavements and S-77-1 for flexible pavements to calculate ACN values. The method of pavement evaluation is left up to the airport with the results of their evaluation presented as follows:

PCN	PAVEMENT TYPE	SUBGRADE CATEGORY	TIRE PRESSURE CATEGORY	EVALUATION METHOD
	R = Rigid F = Flexible	A = High B = Medium C = Low D = Ultra Low	W = No Limit X = To 217 psi (1.5 MPa) Y = To 145 psi (1.0 MPa) Z = To 73 psi (0.5 MPa)	T = Technical U = Using Aircraft

Section 7.10.1 shows the aircraft ACN values for flexible pavements. The four subgrade categories are:

- Code A - High Strength - CBR 15
- Code B - Medium Strength - CBR 10
- Code C - Low Strength - CBR 6
- Code D - Ultra Low Strength - CBR 3

Section 7.10.2 shows the aircraft ACN values for rigid pavements. The four subgrade categories are:

- Code A - High Strength,  $k = 550 \text{ pci (150 MN/m}^3\text{)}$
- Code B - Medium Strength,  $k = 300 \text{ pci (80 MN/m}^3\text{)}$
- Code C - Low Strength,  $k = 150 \text{ pci (40 MN/m}^3\text{)}$
- Code D - Ultra Low Strength,  $k = 75 \text{ pci (20 MN/m}^3\text{)}$

D6-58333

# PRELIMINARY INFORMATION

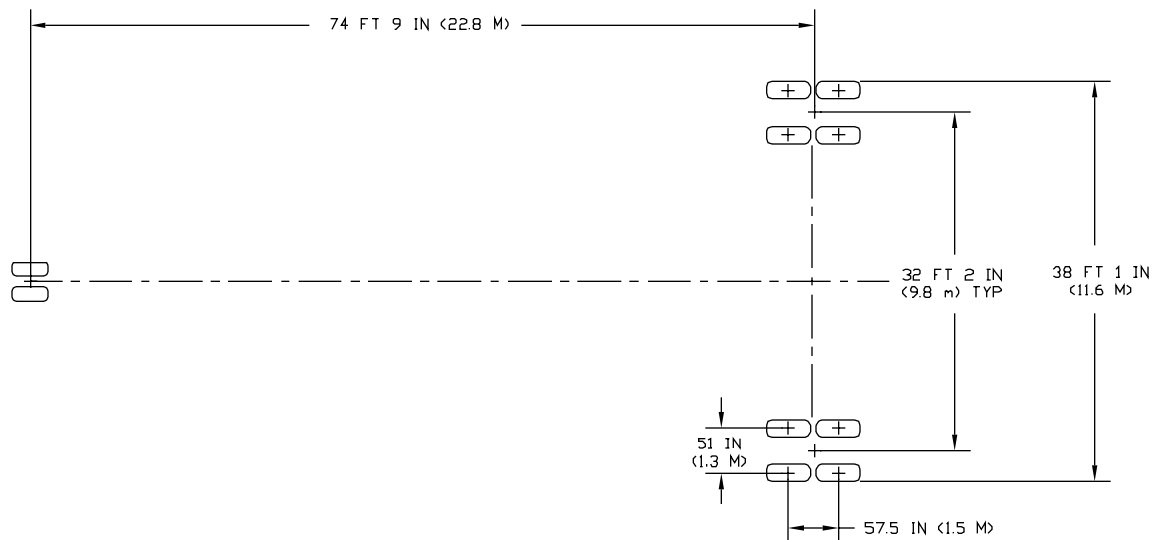

	UNITS	787-8
MAXIMUM DESIGN	LB	486,000
TAXI WEIGHT	KG	220,445
PERCENT OF WEIGHT ON MAIN GEAR		SEE SECTION 7.4
NOSE GEAR TIRE SIZE	IN.	40 x 16.0 R16 26PR
NOSE GEAR TIRE PRESSURE	PSI	187
	KG/CM <sup>2</sup>	13.15
MAIN GEAR TIRE SIZE	IN.	50 x 20.0 R22 34 PR
MAIN GEAR TIRE PRESSURE	PSI	221
	KG/CM <sup>2</sup>	15.47

## 7.2 LANDING GEAR FOOTPRINT

MODEL 787-8

# PRELIMINARY INFORMATION

$V_{(NG)}$  = MAXIMUM VERTICAL NOSE GEAR GROUND LOAD AT MOST FORWARD CENTER OF GRAVITY

$V_{(MG)}$  = MAXIMUM VERTICAL MAIN GEAR GROUND LOAD AT MOST AFT CENTER OF GRAVITY

H = MAXIMUM HORIZONTAL GROUND LOAD FROM BRAKING

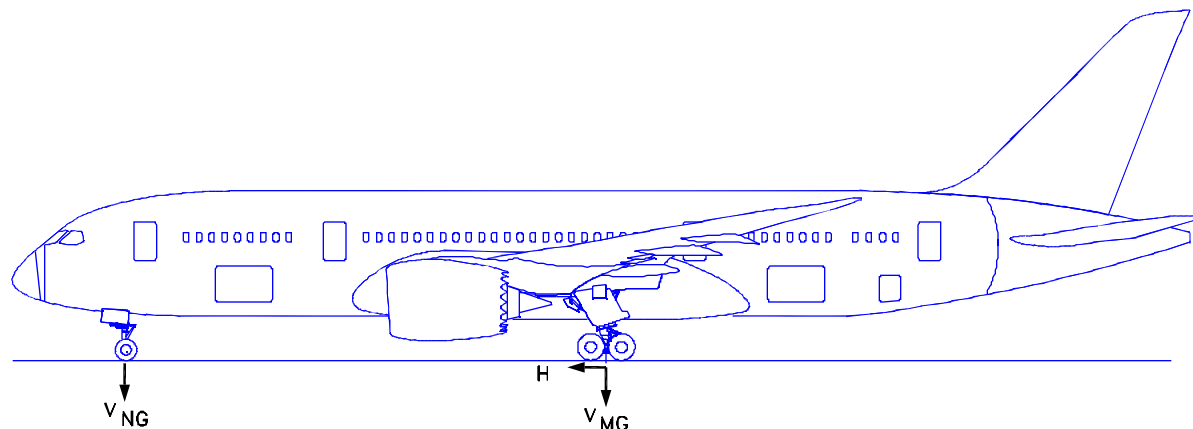

NOTE: ALL LOADS CALCULATED USING AIRPLANE MAXIMUM DESIGN TAXI WEIGHT

MODEL	UNIT	MAXIMUM DESIGN TAXI WEIGHT	$V_{(NG)}$		$V_{(MG)}$ PER STRUT	H PER STRUT	
			STATIC AT MOST FWD C.G.	STATIC + BRAKING 10 FT/SEC <sup>2</sup> DECEL	MAX LOAD AT STATIC AFT C.G.	STEADY BRAKING 10 FT/SEC <sup>2</sup> DECEL	AT INSTANTANEOUS BRAKING ( $\mu=0.8$ )
787-8	LB	486,000	51,208	80,524	222,012	75,476	177,609
	KG	220,445	23,228	36,525	100,703	34,235	80,562

## 7.3 MAXIMUM PAVEMENT LOADS

*MODEL 787-8*



# PRELIMINARY INFORMATION

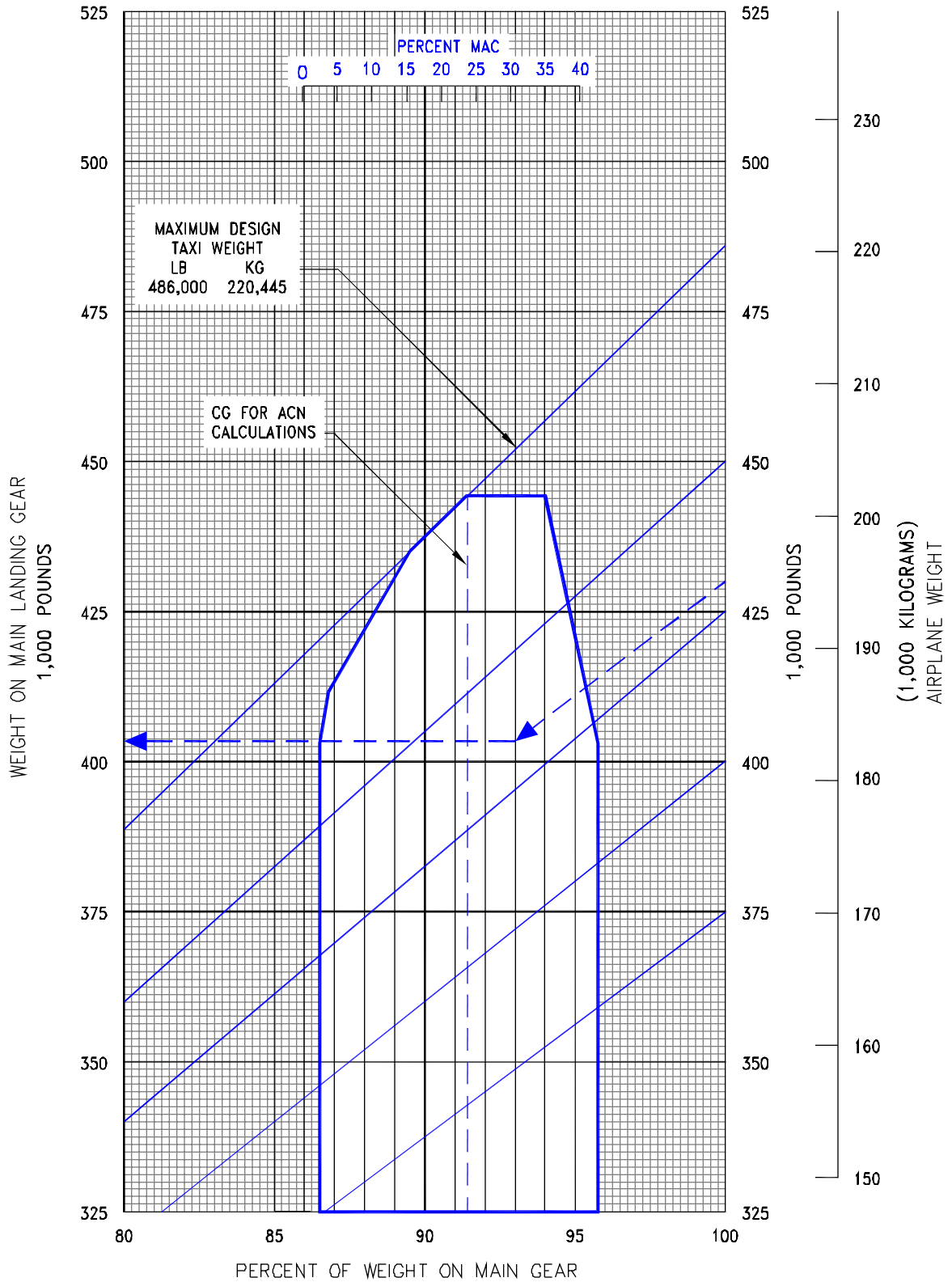

## 7.4 LANDING GEAR LOADING ON PAVEMENT

MODEL 787-8

D6-58333

# PRELIMINARY INFORMATION

## **7.5 Flexible Pavement Requirements - U.S. Army Corps of Engineers Method (S-77-1)**

The following flexible-pavement design chart presents the data of five incremental main-gear loads at the minimum tire pressure required at the maximum design taxi weight.

In the example shown, for a CBR of 25 and an annual departure level of 25,000, the required flexible pavement thickness for an airplane with a main gear loading of 300,000 pounds is 12.6 inches.

The line showing 10,000 coverages is used for ACN calculations (see Section 7.10).

The FAA design method uses a similar procedure using total airplane weight instead of weight on the main landing gears. The equivalent main gear loads for a given airplane weight could be calculated from Section 7.4.

# PRELIMINARY INFORMATION

NOTE: TIRES - 50 x 20 R22 34 PR AT 221 PSI (15.47 KG/CM SQ)  
CALIFORNIA BEARING RATIO, CBR

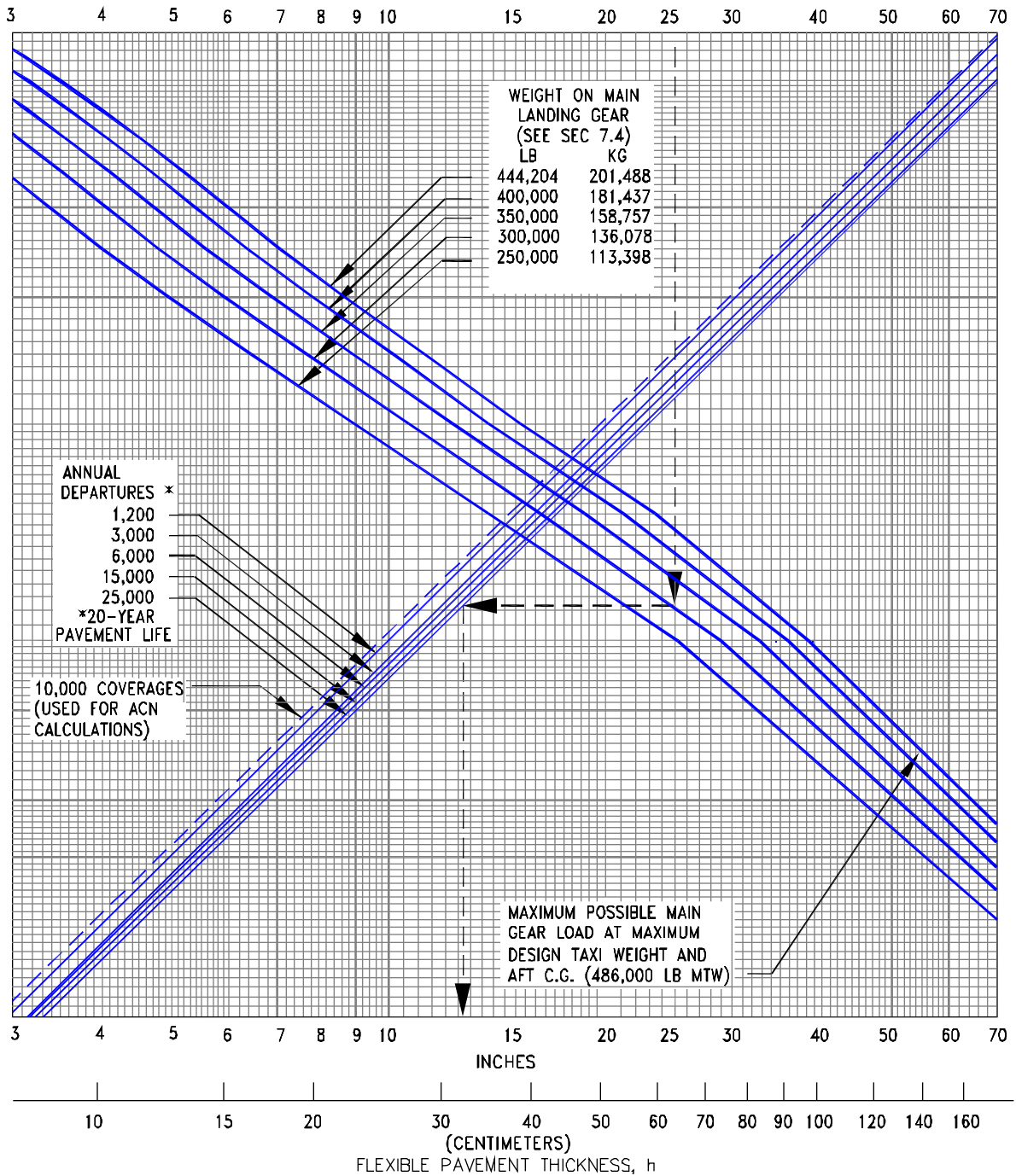

## 7.5.1 FLEXIBLE PAVEMENT REQUIREMENTS - U.S. ARMY CORPS OF ENGINEERS DESIGN METHOD (S-77-1) MODEL 787-8

# PRELIMINARY INFORMATION

## 7.6 Flexible Pavement Requirements - LCN Method

To determine the airplane weight that can be accommodated on a particular flexible pavement, both the Load Classification Number (LCN) of the pavement and the thickness must be known.

In the example shown, flexible pavement thickness is shown at 28 in. with an LCN of 90. For these conditions, the apparent maximum allowable weight permissible on the main landing gear is 350,000 lb for an airplane with 221-psi main gear tires.

Note: If the resultant aircraft LCN is not more than 10% above the published pavement LCN, the bearing strength of the pavement can be considered sufficient for unlimited use by the airplane. The figure 10% has been chosen as representing the lowest degree of variation in LCN that is significant (reference: ICAO Aerodrome Manual, Part 2, "Aerodrome Physical Characteristics," Chapter 4, Paragraph 4.1.5.7v, 2nd Edition dated 1965).

# PRELIMINARY INFORMATION

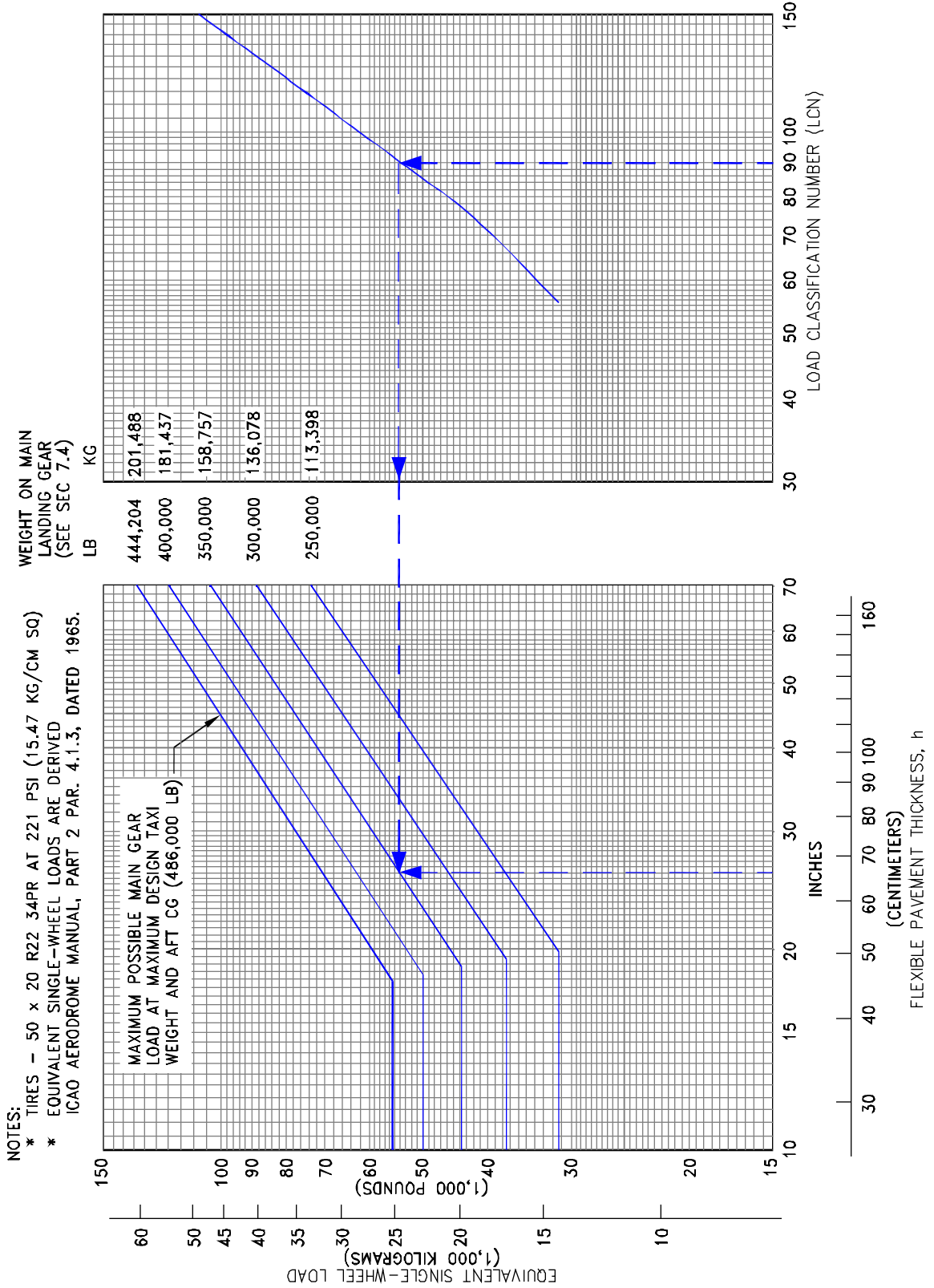

## 7.6.1 FLEXIBLE PAVEMENT REQUIREMENTS - LCN METHOD MODEL 787-8

# PRELIMINARY INFORMATION

## **7.7 Rigid Pavement Requirements - Portland Cement Association Design Method**

The Portland Cement Association method of calculating rigid pavement requirements is based on the computerized version of "Design of Concrete Airport Pavement" (Portland Cement Association, 1955) as described in XP6705-2, "Computer Program for Airport Pavement Design" by Robert G. Packard, Portland Cement Association, 1968.

The following rigid pavement design chart presents the data for five incremental main gear loads at the minimum tire pressure required at the maximum design taxi weight.

In the example shown, for an allowable working stress of 550 psi, a main gear load of 444,204 lb, and a subgrade strength (k) of 300, the required rigid pavement thickness is 11.0 in.

# PRELIMINARY INFORMATION

NOTE: TIRES - 50 x 20 R22 34 PR AT 221 PSI (15.47 KG/CM SQ)

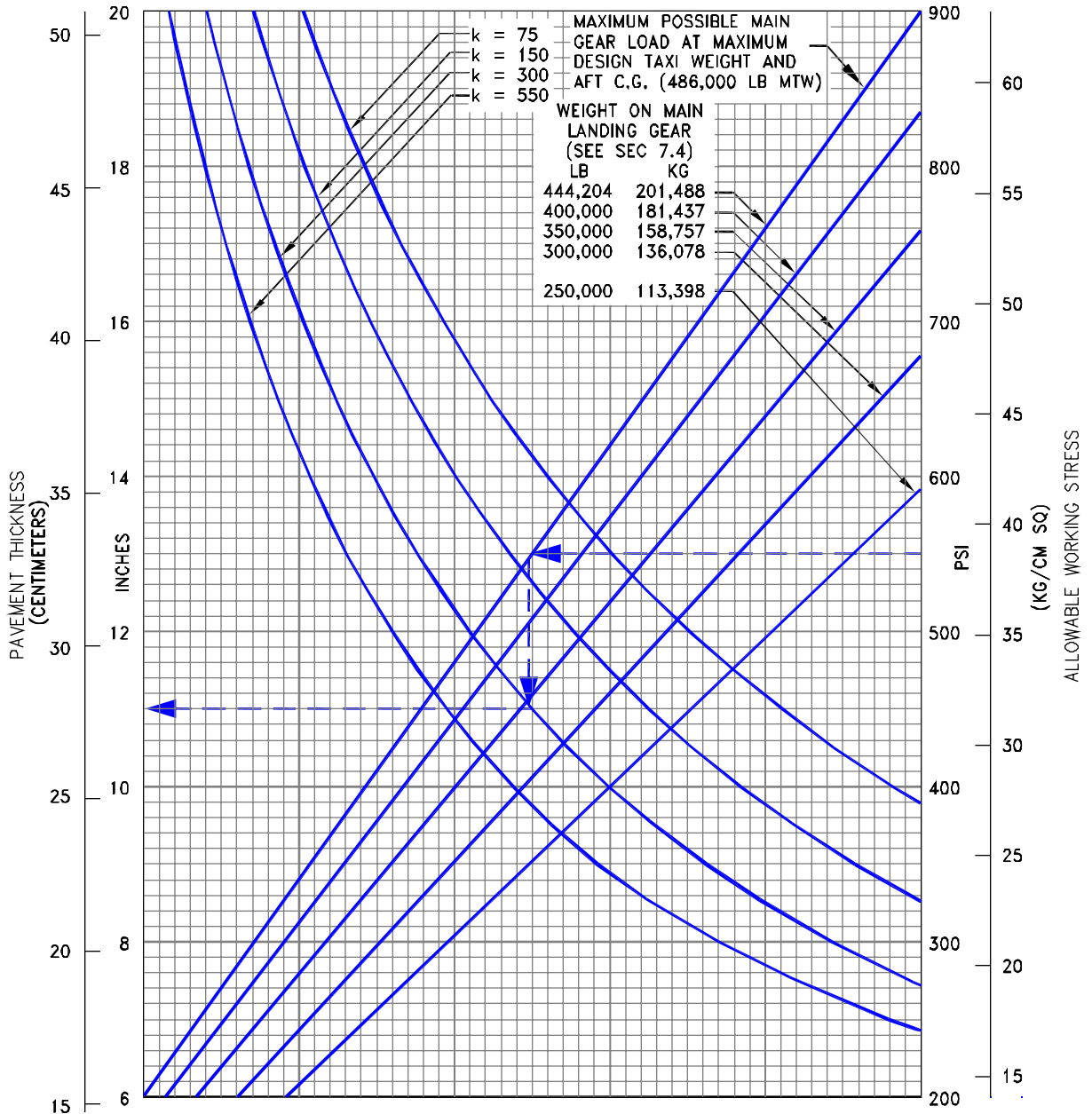

NOTE:  
 THE VALUES OBTAINED BY USING THE MAXIMUM LOAD REFERENCE LINE AND ANY VALUE OF k ARE EXACT. FOR LOADS LESS THAN MAXIMUM, THE CURVES ARE EXACT FOR k = 300 BUT DEVIATE SLIGHTLY FOR OTHER VALUES OF k.

REFERENCES:  
 "DESIGN OF CONCRETE AIRPORT PAVEMENT" AND "COMPUTER PROGRAM FOR AIRPORT PAVEMENT DESIGN - PROGRAM PDILB" PORTLAND CEMENT ASSOCIATION.

## 7.7.1 RIGID PAVEMENT REQUIREMENTS - PORTLAND CEMENT ASSOCIATION DESIGN METHOD MODEL 787-8

# PRELIMINARY INFORMATION

## 7.8 Rigid Pavement Requirements - LCN Conversion

To determine the airplane weight that can be accommodated on a particular rigid pavement, both the LCN of the pavement and the radius of relative stiffness ( $l$ ) of the pavement must be known.

In the example shown in 7.8.2, for a rigid pavement with a radius of relative stiffness of 39 with an LCN of 88, the apparent maximum allowable weight permissible on the main landing gear is 350,000 lb for an airplane with 221-psi main tires.

Note: If the resultant aircraft LCN is not more than 10% above the published pavement LCN, the bearing strength of the pavement can be considered sufficient for unlimited use by the airplane. The figure 10% has been chosen as representing the lowest degree of variation in LCN that is significant (reference: ICAO Aerodrome Manual, Part 2, "Aerodrome Physical Characteristics," Chapter 4, Paragraph 4.1.5.7v, 2nd Edition dated 1965).



# PRELIMINARY INFORMATION

RADIUS OF RELATIVE STIFFNESS (ℓ)  
VALUES IN INCHES

$$\ell = \sqrt[4]{\frac{Ed^3}{12(1-\mu^2)k}} = 24.1652 \sqrt[4]{\frac{d^3}{k}}$$

WHERE: E = YOUNG'S MODULUS OF ELASTICITY =  $4 \times 10^6$  psi

k = SUBGRADE MODULUS, LB PER CU IN

d = RIGID PAVEMENT THICKNESS, IN

μ = POISSON'S RATIO = 0.15

d	k = 75	k = 100	k = 150	k = 200	k = 250	k = 300	k = 350	k = 400	k = 500	k = 550
6.0	31.48	29.29	26.47	24.63	23.30	22.26	21.42	20.71	19.59	19.13
6.5	33.42	31.10	28.11	26.16	24.74	23.63	22.74	21.99	20.80	20.31
7.0	35.33	32.88	29.71	27.65	26.15	24.99	24.04	23.25	21.99	21.47
7.5	37.21	34.63	31.29	29.12	27.54	26.31	25.32	24.49	23.16	22.61
8.0	39.06	36.35	32.84	30.56	28.91	27.62	26.57	25.70	24.31	23.73
8.5	40.87	38.04	34.37	31.99	30.25	28.90	27.81	26.90	25.44	24.84
9.0	42.66	39.70	35.88	33.39	31.57	30.17	29.03	28.07	26.55	25.93
9.5	44.43	41.35	37.36	34.77	32.88	31.42	30.23	29.24	27.65	27.00
10.0	46.17	42.97	38.83	36.13	34.17	32.65	31.41	30.38	28.73	28.06
10.5	47.89	44.57	40.27	37.48	35.44	33.87	32.58	31.52	29.81	29.10
11.0	49.59	46.15	41.70	38.81	36.70	35.07	33.74	32.63	30.86	30.14
11.5	51.27	47.72	43.12	40.12	37.95	36.26	34.89	33.74	31.91	31.16
12.0	52.94	49.26	44.51	41.43	39.18	37.43	36.02	34.83	32.94	32.17
12.5	54.58	50.80	45.90	42.71	40.40	38.60	37.14	35.92	33.97	33.17
13.0	56.21	52.31	47.27	43.99	41.60	39.75	38.25	36.99	34.98	34.16
13.5	57.83	53.81	48.63	45.25	42.80	40.89	39.34	38.05	35.99	35.14
14.0	59.43	55.30	49.97	46.50	43.98	42.02	40.43	39.10	36.98	36.11
14.5	61.01	56.78	51.30	47.74	45.15	43.14	41.51	40.15	37.97	37.07
15.0	62.58	58.24	52.62	48.97	46.32	44.25	42.58	41.18	38.95	38.03
15.5	64.14	59.69	53.93	50.19	47.47	45.35	43.64	42.21	39.92	38.98
16.0	65.69	61.13	55.23	51.40	48.61	46.45	44.69	43.22	40.88	39.92
16.5	67.22	62.55	56.52	52.60	49.75	47.53	45.73	44.23	41.83	40.85
17.0	68.74	63.97	57.80	53.79	50.87	48.61	46.77	45.23	42.78	41.77
17.5	70.25	65.38	59.07	54.97	51.99	49.68	47.80	46.23	43.72	42.69
18.0	71.75	66.77	60.34	56.15	53.10	50.74	48.82	47.22	44.65	43.60
19.0	74.72	69.54	62.83	58.47	55.30	52.84	50.84	49.17	46.50	45.41
20.0	77.65	72.26	65.30	60.77	57.47	54.91	52.83	51.10	48.33	47.19
21.0	80.55	74.96	67.73	63.03	59.61	56.95	54.80	53.00	50.13	48.95
22.0	83.41	77.62	70.14	65.27	61.73	58.98	56.75	54.88	51.91	50.68
23.0	86.23	80.25	72.51	67.48	63.82	60.98	58.67	56.74	53.67	52.40
24.0	89.03	82.85	74.86	69.67	65.89	62.95	60.57	58.58	55.41	54.10
25.0	91.80	85.43	77.19	71.84	67.94	64.91	62.46	60.41	57.13	55.78

## 7.8.1 RADIUS OF RELATIVE STIFFNESS (REFERENCE: PORTLAND CEMENT ASSOCIATION)

# PRELIMINARY INFORMATION

NOTES: \* TIRES - 50 x 20 R22 34PR AT 221 PSI (15.47 KG/CM SQ)  
 \* EQUIVALENT SINGLE-WHEEL LOADS ARE DERIVED FROM ICAO AERODROME MANUAL, PART 2 PAR 4.1.3, DATED 1965.

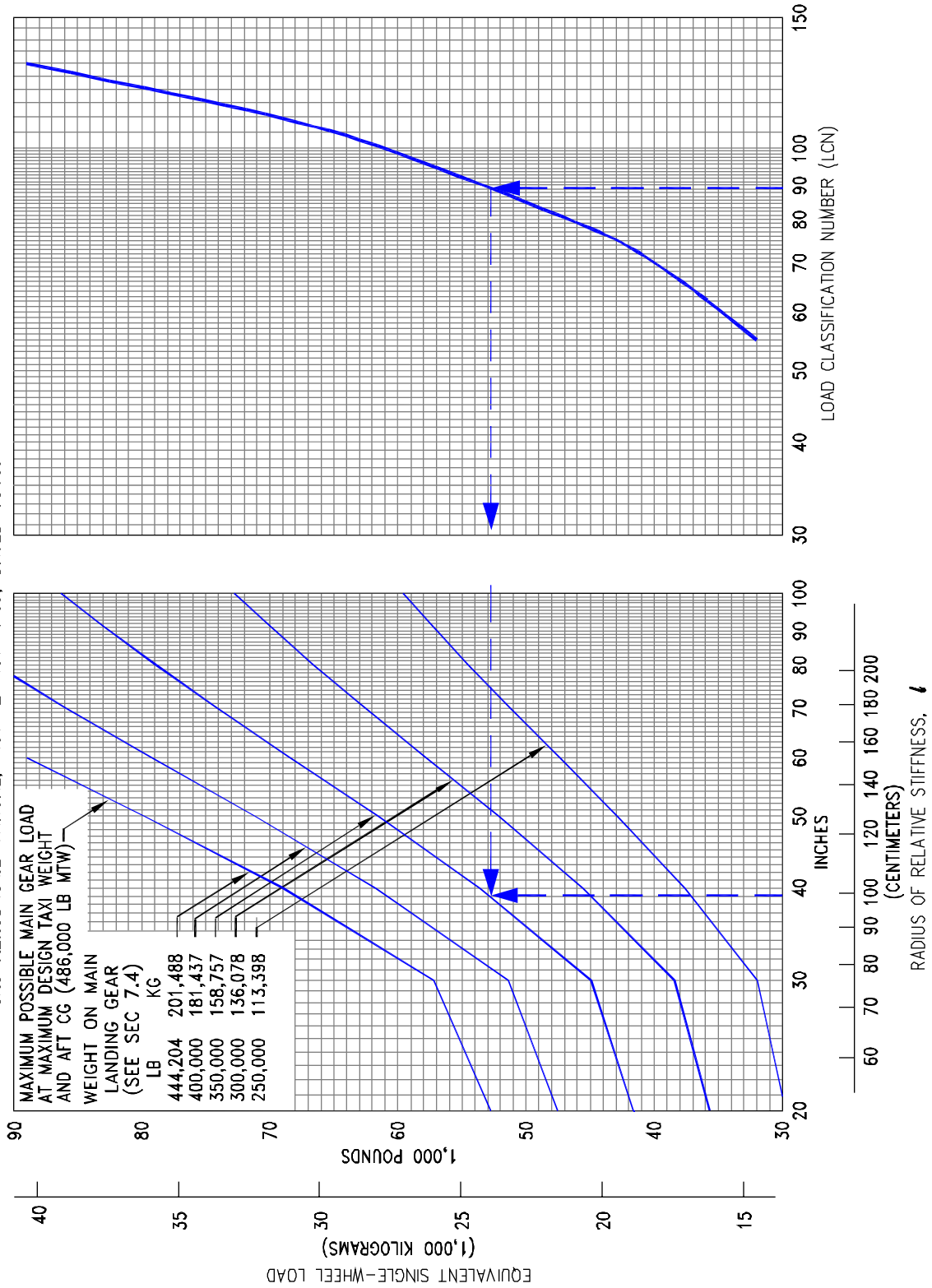

## 7.8.2 RIGID PAVEMENT REQUIREMENTS - LCN CONVERSION

MODEL 787-8

# PRELIMINARY INFORMATION

## **7.9 Rigid Pavement Requirements - FAA Design Method**

The following rigid-pavement design chart presents data on five incremental main gear loads at the minimum tire pressure required at the maximum design taxi weight.

In the example shown, the pavement flexural strength is shown at 700 psi, the subgrade strength is shown at  $k = 550$ , and the annual departure level is 6,000. For these conditions, the required rigid pavement thickness for an airplane with a main gear loading of 400,000 pounds is 12.0 inches.

# PRELIMINARY INFORMATION

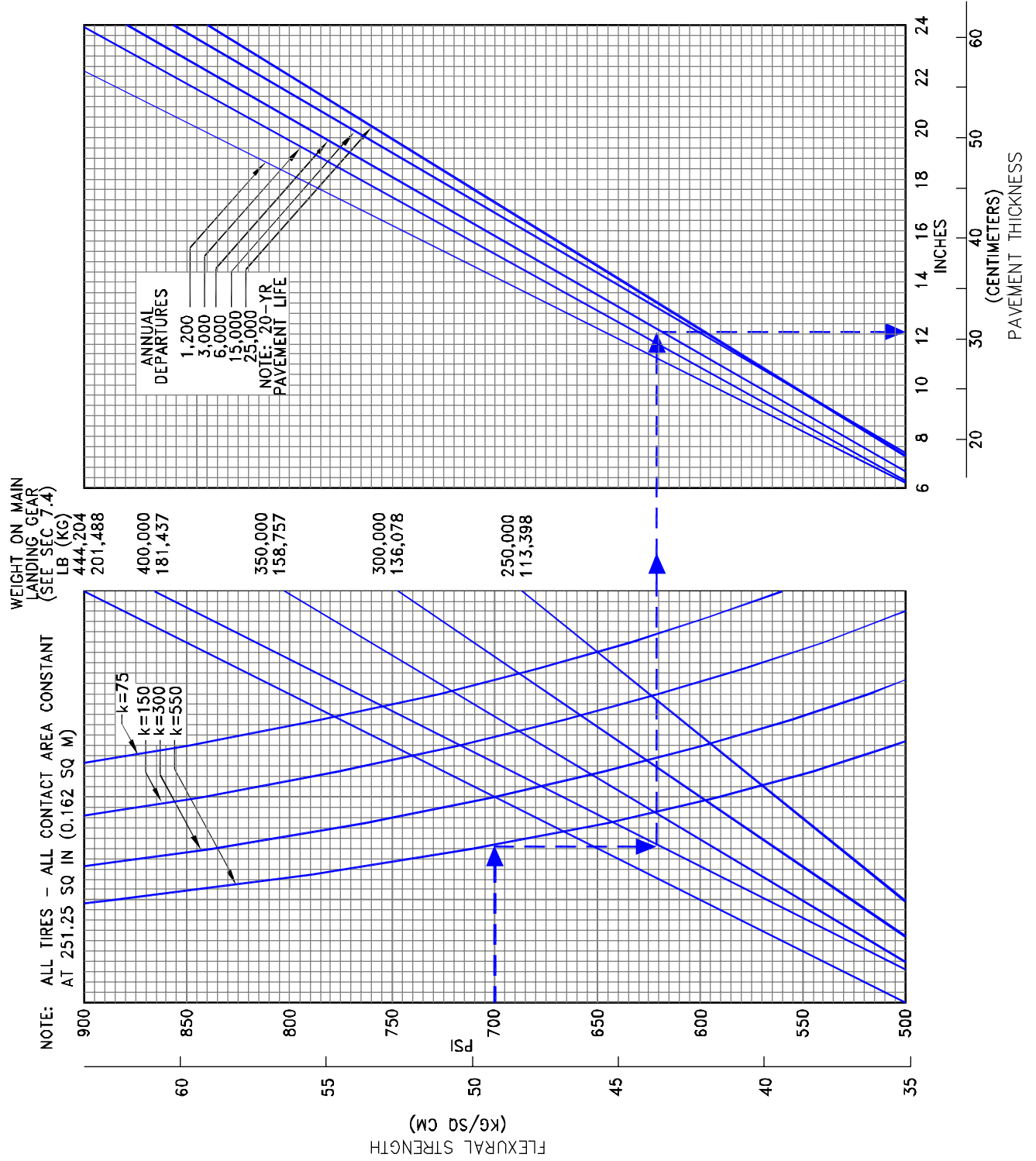

## 7.9.1 RIGID PAVEMENT REQUIREMENTS - FAA METHOD MODEL 787-8

# PRELIMINARY INFORMATION

## 7.10 ACN/PCN Reporting System - Flexible and Rigid Pavements

To determine the ACN of an aircraft on flexible or rigid pavement, both the aircraft gross weight and the subgrade strength category must be known. In the chart in 7.10.1, for an aircraft with gross weight of 270,000 lb on a low subgrade strength (Code C), the flexible pavement ACN is 32. Referring to 7.10.2, the same aircraft on a low subgrade rigid pavement has an ACN of 36.

The following table provides ACN data in tabular format similar to the one used by ICAO in the “Aerodrome Design Manual Part 3, Pavements.” If the ACN for an intermediate weight between taxi weight and empty fuel weight of the aircraft is required, Figures 7.10.1 through 7.10.2 should be consulted.

AIRCRAFT TYPE	MAXIMUM TAXI WEIGHT/ MINIMUM WT (1) LB (KG)	LOAD ON ONE MAIN GEAR LEG (%)	TIRE PRESSURE PSI (MPa)	ACN FOR RIGID PAVEMENT SUBGRADES – MN/m <sup>2</sup>				ACN FOR FLEXIBLE PAVEMENT SUBGRADES – CBR			
				HIGH 150	MEDIUM 80	LOW 40	ULTRA LOW 20	HIGH 15	MEDIUM 10	LOW 6	ULTRA LOW 3
787-8	486,000(220,445)	45.70	221 (1.52)	57	67	79	91	57	63	77	101
	237,400(107,683)			28	31	36	42	24	25	28	36

(1) Minimum weight used solely as a baseline for ACN curve generation.

# PRELIMINARY INFORMATION

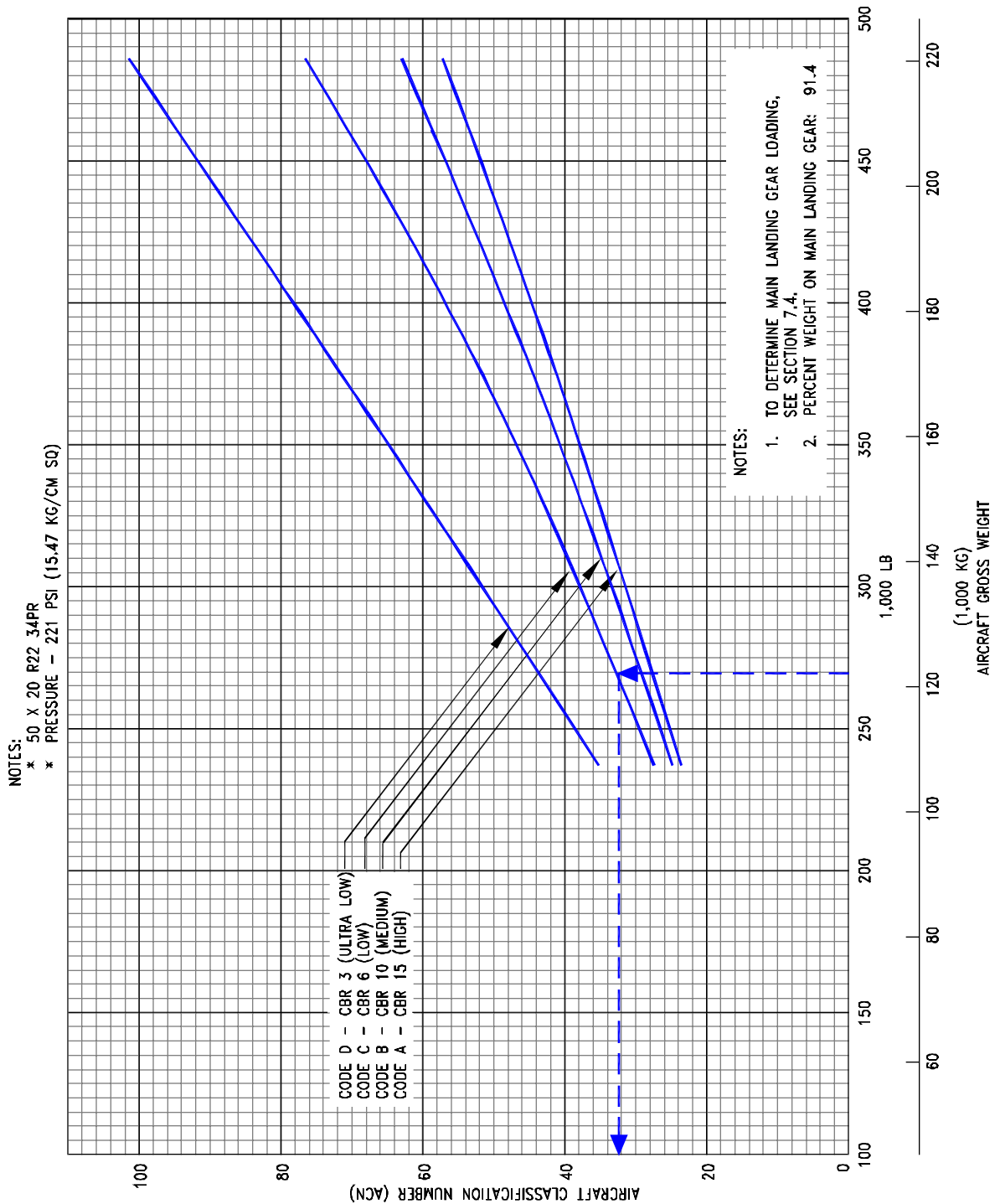

## 7.10.1 AIRCRAFT CLASSIFICATION NUMBER - FLEXIBLE PAVEMENT MODEL 787-8

# PRELIMINARY INFORMATION

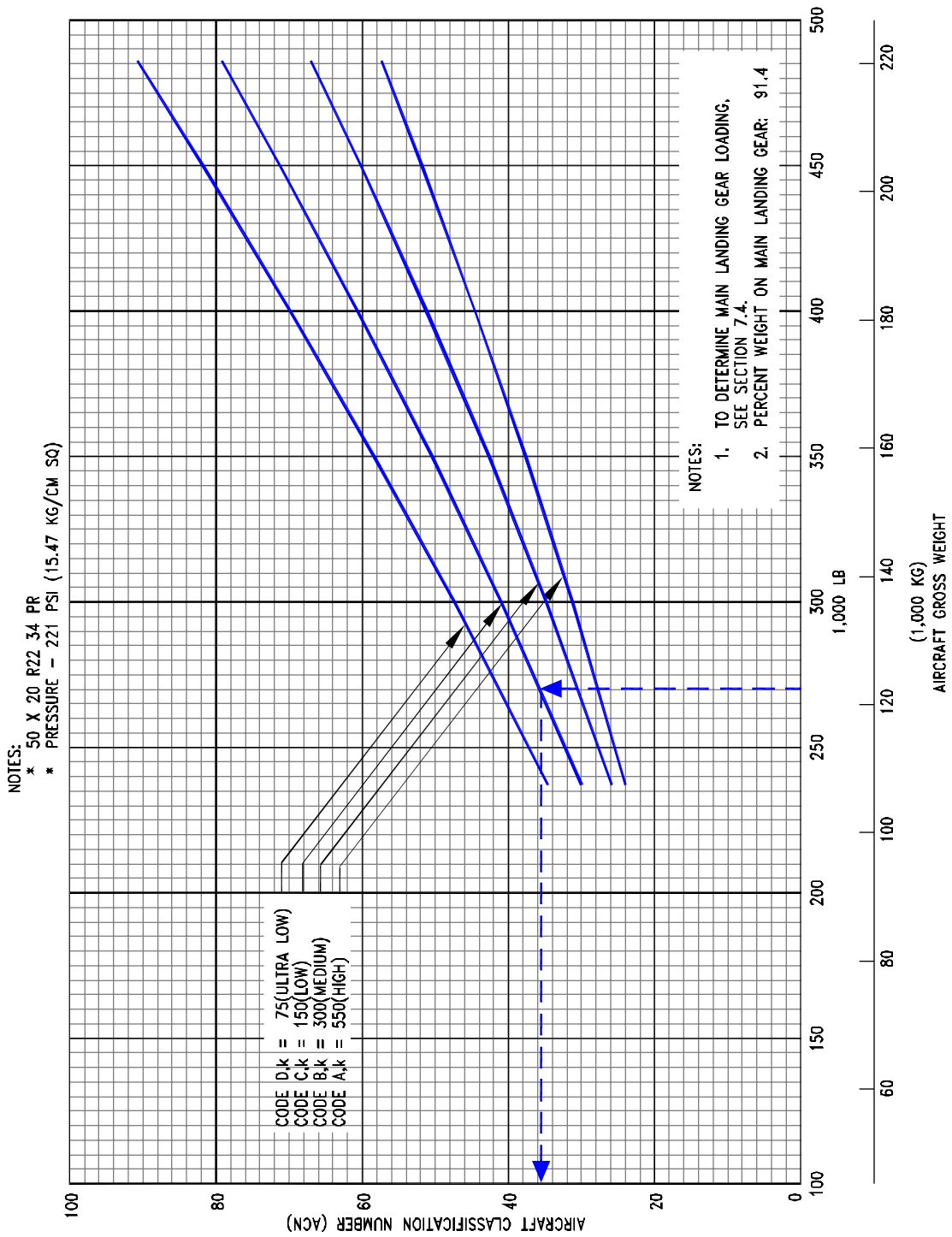

## 7.10.2 AIRCRAFT CLASSIFICATION NUMBER - RIGID PAVEMENT MODEL 787-8

# PRELIMINARY INFORMATION

THIS PAGE INTENTIONALLY LEFT BLANK



# PRELIMINARY INFORMATION

## **8.0 FUTURE 787 DERIVATIVE AIRPLANES**

# PRELIMINARY INFORMATION

## **8.0 FUTURE 787 DERIVATIVE AIRPLANES**

Several derivatives are being studied to provide additional capabilities of the 787 family of airplanes. Future growth versions could address additional passenger count, or cargo capacity, or increased range.

The derivatives that are currently being studied are the -3, and -9. The -3 is a short-range derivative of the 787-8 with the same fuselage size and passenger count. The -9 is a longer-body version of the -8 and is a long-range aircraft with increased passenger count over the -8. Several wing configurations and wingspans are also being studied to address increased payload and range requirements.

Whether these growth versions could be built would depend entirely on airline requirements. In any event, impact on airport facilities will be a consideration in the configuration and design.

# PRELIMINARY INFORMATION

## **9.0 SCALED 787 DRAWINGS**

### **9.1 – 9.5 Model 787-8**

# PRELIMINARY INFORMATION

## 9.0 SCALED DRAWINGS

The drawings in the following pages show airplane plan view drawings, drawn to approximate scale as noted. The drawings may not come out to exact scale when printed or copied from this document. Printing scale should be adjusted when attempting to reproduce these drawings. Three-view drawing files of the 787-8, along with other Boeing airplane models, can be downloaded from the following website:

<http://www.boeing.com/airports>

# PRELIMINARY INFORMATION

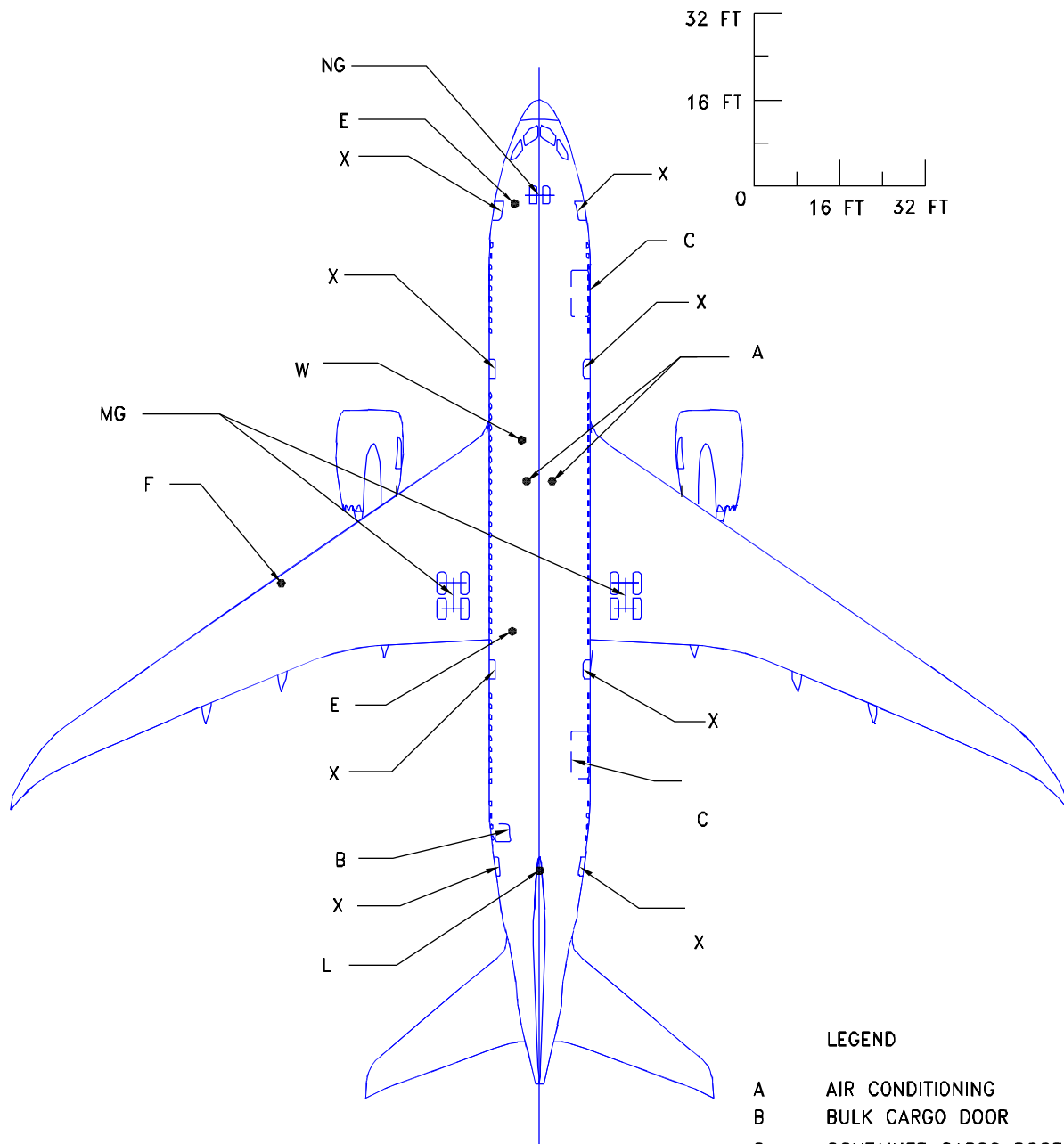

## LEGEND

A	AIR CONDITIONING
B	BULK CARGO DOOR
C	CONTAINER CARGO DOOR
E	ELECTRICAL
F	FUEL
L	LAVATORY
MG	MAIN GEAR
NG	NOSE GEAR
W	POTABLE WATER
X	PASSENGER DOOR

**NOTE: WHEN PRINTING THIS DRAWING, MAKE SURE TO ADJUST FOR PROPER SCALING**

**9.1.1 SCALED DRAWING - 1 IN. = 32 FT**  
*MODEL 787-8*

D6-58333

# PRELIMINARY INFORMATION

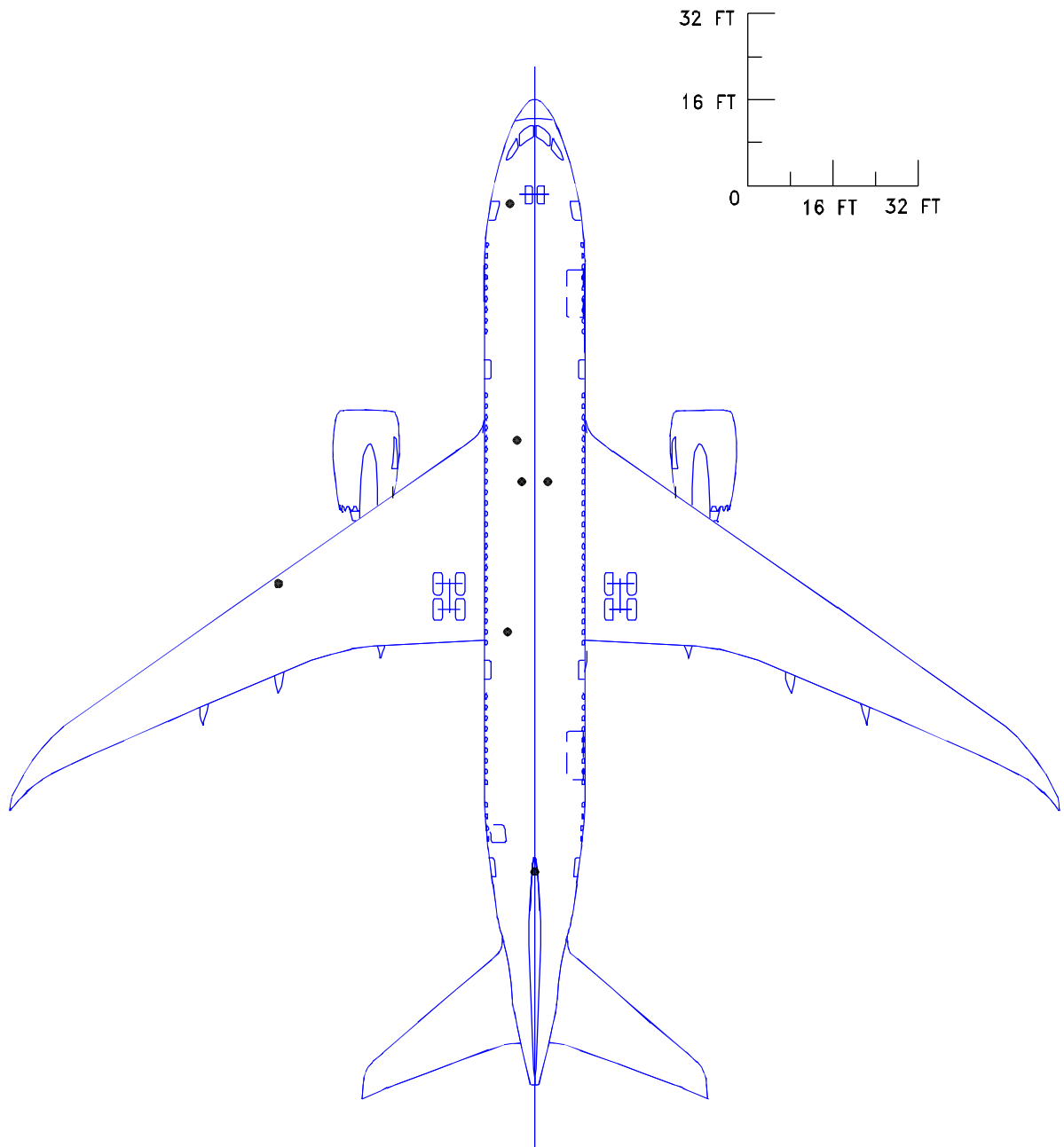

**NOTE: WHEN PRINTING THIS DRAWING, MAKE SURE TO ADJUST FOR PROPER SCALING**

**9.1.2 SCALED DRAWING - 1 IN. = 32 FT**  
*MODEL 787-8*

# PRELIMINARY INFORMATION

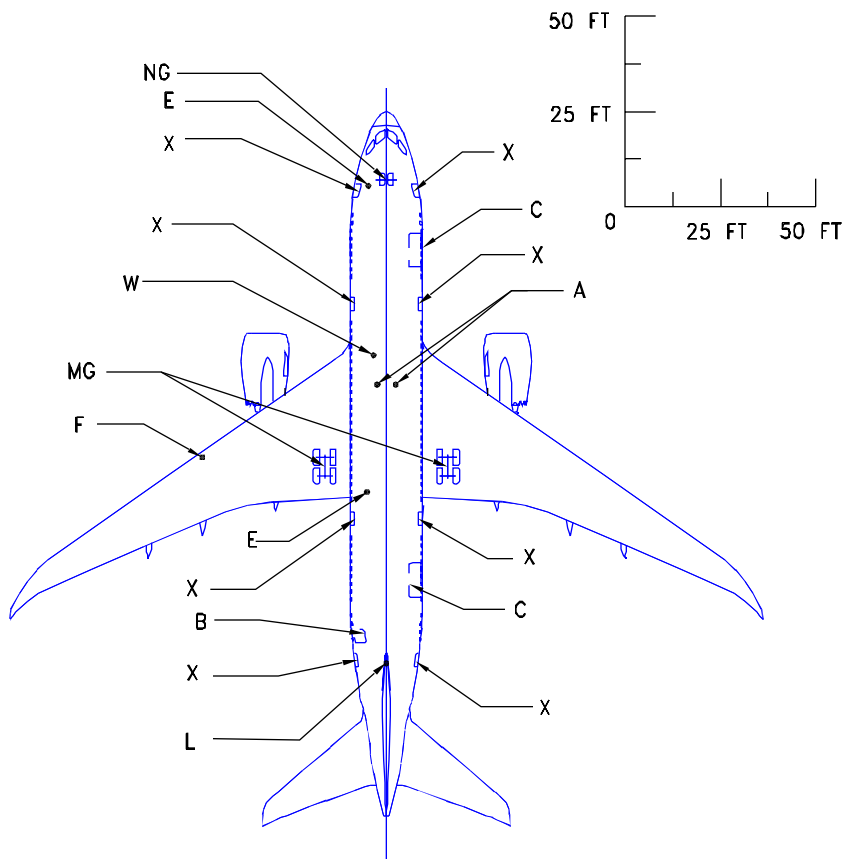

## LEGEND

A	AIR CONDITIONING
B	BULK CARGO DOOR
C	CONTAINER CARGO DOOR
E	ELECTRICAL
F	FUEL
L	LAVATORY
MG	MAIN GEAR
NG	NOSE GEAR
W	POTABLE WATER
X	PASSENGER DOOR

**NOTE: WHEN PRINTING THIS DRAWING, MAKE SURE TO ADJUST FOR PROPER SCALING**

### 9.2.1 SCALED DRAWING - 1 IN. = 50 FT

*MODEL 787-8*

D6-58333

REV A

SEPTEMBER 2007 103

# PRELIMINARY INFORMATION

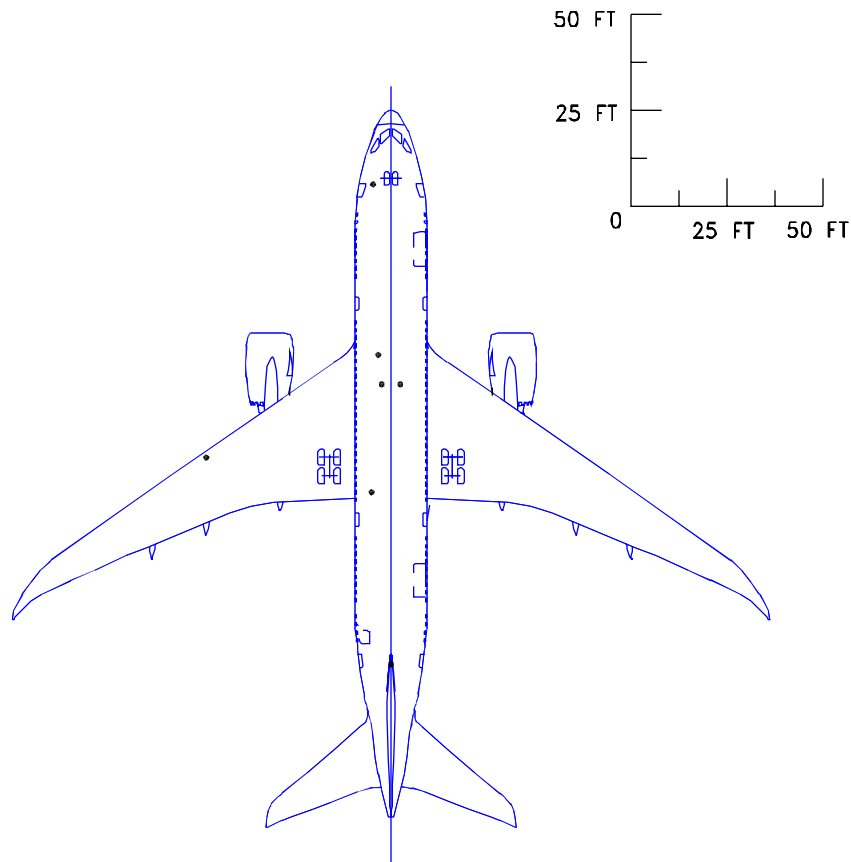

**NOTE: WHEN PRINTING THIS DRAWING, MAKE SURE TO ADJUST FOR PROPER SCALING**

**9.2.2 SCALED DRAWING - 1 IN. = 50 FT**  
*MODEL 787-8*



# PRELIMINARY INFORMATION

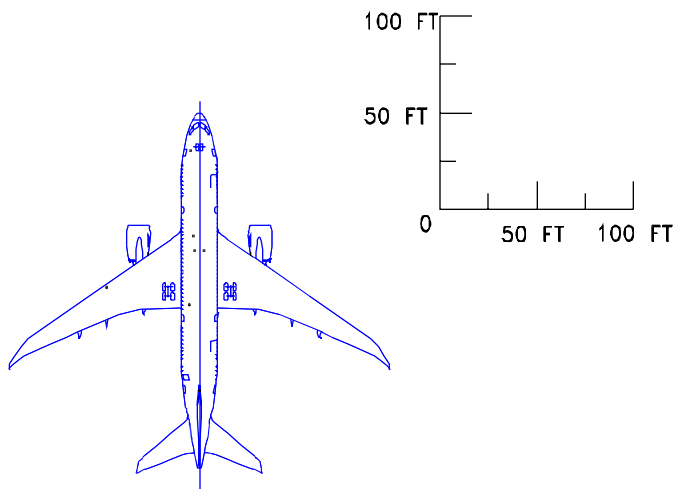

NOTE:

SEE CORRESPONDING PAGE FOR 1 IN = 32 FT  
FOR IDENTIFICATIONS OF SERVICE POINTS

## LEGEND

A	AIR CONDITIONING
B	BULK CARGO DOOR
C	CONTAINER CARGO DOOR
E	ELECTRICAL
F	FUEL
L	LAVATORY
MG	MAIN GEAR
NG	NOSE GEAR
W	POTABLE WATER
X	PASSENGER DOOR

**NOTE: WHEN PRINTING THIS DRAWING, MAKE SURE TO ADJUST FOR PROPER SCALING**

### 9.3.1 SCALED DRAWING - 1 IN = 100 FT

*MODEL 787-8*

D6-58333

# PRELIMINARY INFORMATION

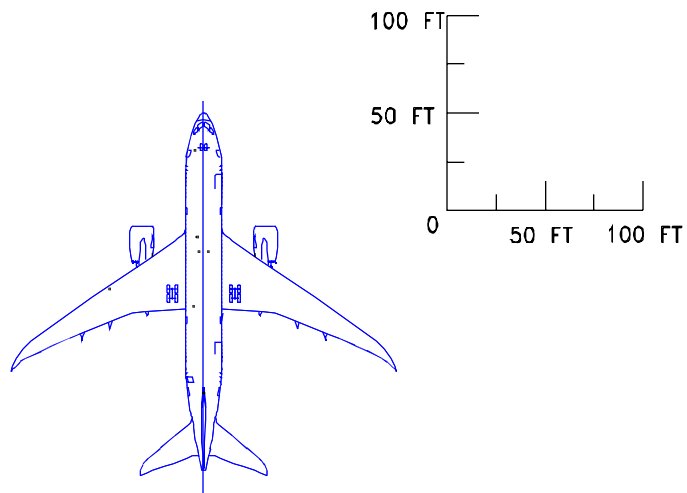

**NOTE: WHEN PRINTING THIS DRAWING, MAKE SURE TO ADJUST FOR PROPER SCALING**

**9.3.2 SCALED DRAWING - 1 IN = 100 FT**  
*MODEL 787-8*

# PRELIMINARY INFORMATION

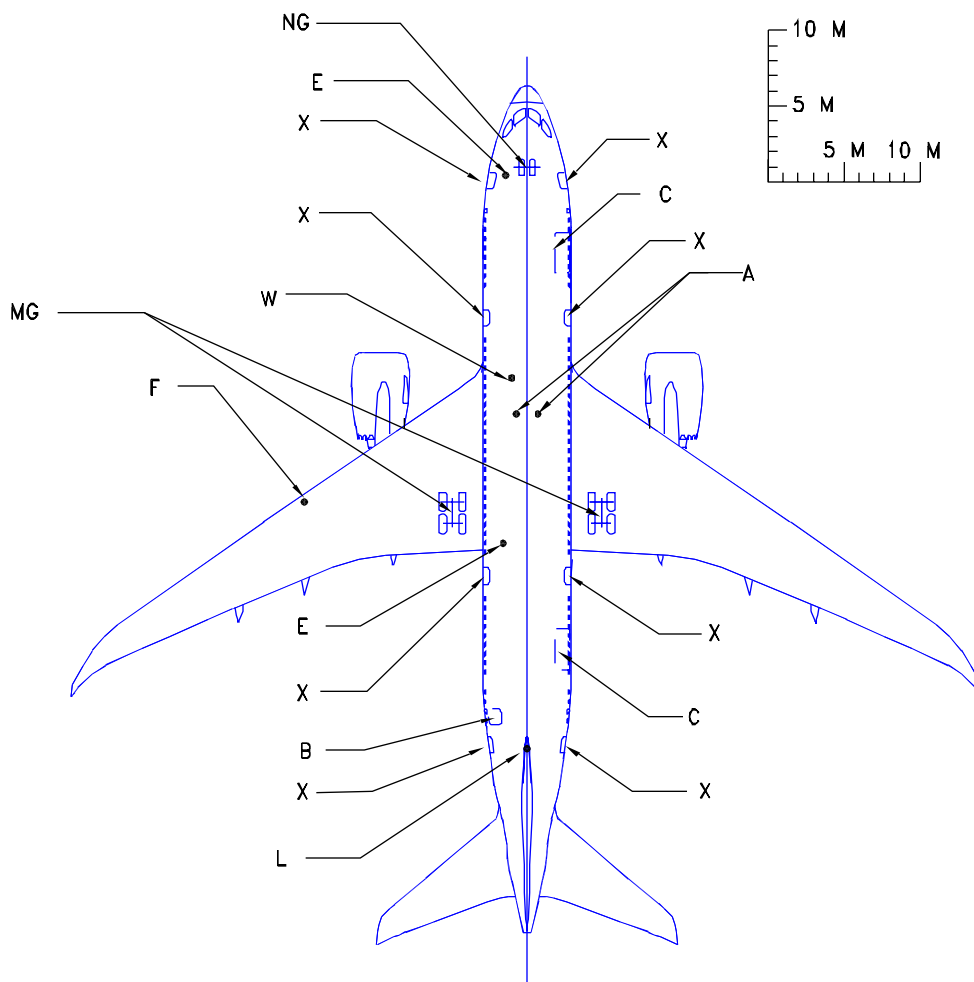

## LEGEND

A	AIR CONDITIONING
B	BULK CARGO DOOR
C	CONTAINER CARGO DOOR
E	ELECTRICAL
F	FUEL
L	LAVATORY
MG	MAIN GEAR
NG	NOSE GEAR
W	POTABLE WATER
X	PASSENGER DOOR

**NOTE: WHEN PRINTING THIS DRAWING, MAKE SURE TO ADJUST FOR PROPER SCALING**

### 9.4.1 SCALED DRAWING - 1:500

*MODEL 787-8*

D6-58333

REV A

SEPTEMBER 2007 107

# PRELIMINARY INFORMATION

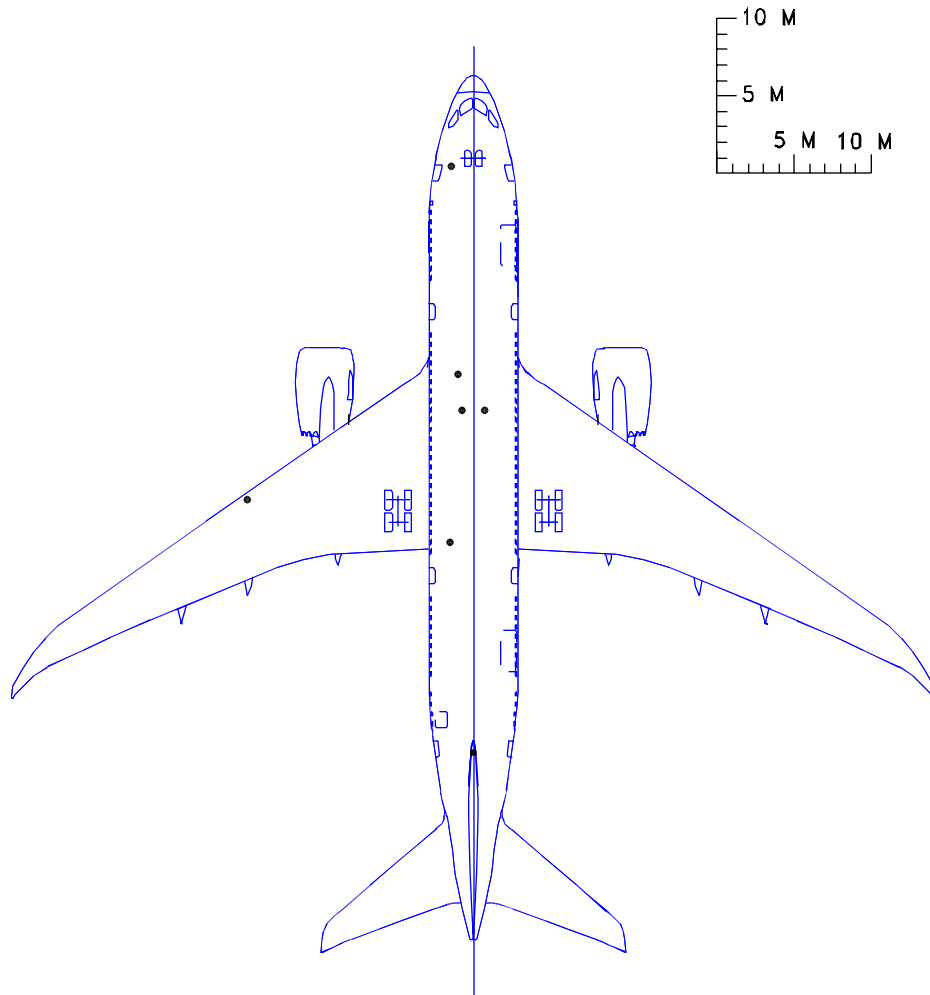

**NOTE: WHEN PRINTING THIS DRAWING, MAKE SURE TO ADJUST FOR PROPER SCALING**

**9.4.2 SCALED DRAWING - 1:500**  
*MODEL 787-8*

D6-58333

# PRELIMINARY INFORMATION

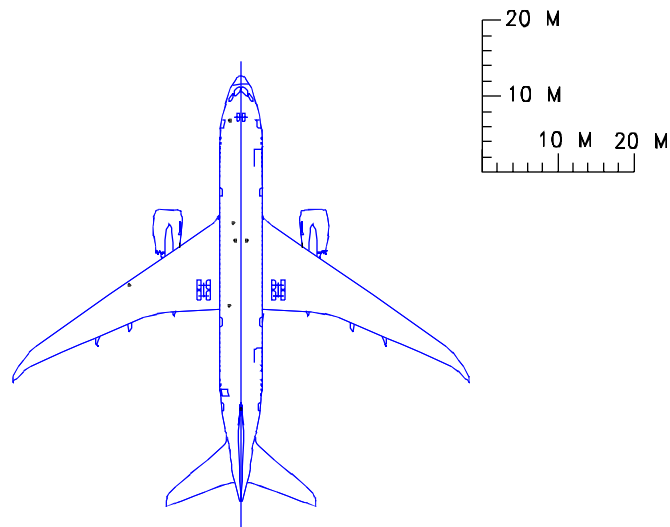

NOTE:

SEE CORRESPONDING PAGE FOR 1 IN = 32 FT  
FOR IDENTIFICATIONS OF SERVICE POINTS

## LEGEND

A	AIR CONDITIONING
B	BULK CARGO DOOR
C	CONTAINER CARGO DOOR
E	ELECTRICAL
F	FUEL
L	LAVATORY
MG	MAIN GEAR
NG	NOSE GEAR
W	POTABLE WATER
X	PASSENGER DOOR

**NOTE: WHEN PRINTING THIS DRAWING, MAKE SURE TO ADJUST FOR PROPER SCALING**

### 9.5.1 SCALED DRAWING - 1:1000

*MODEL 787-8*

D6-58333

REV A

SEPTEMBER 2007 109

# PRELIMINARY INFORMATION

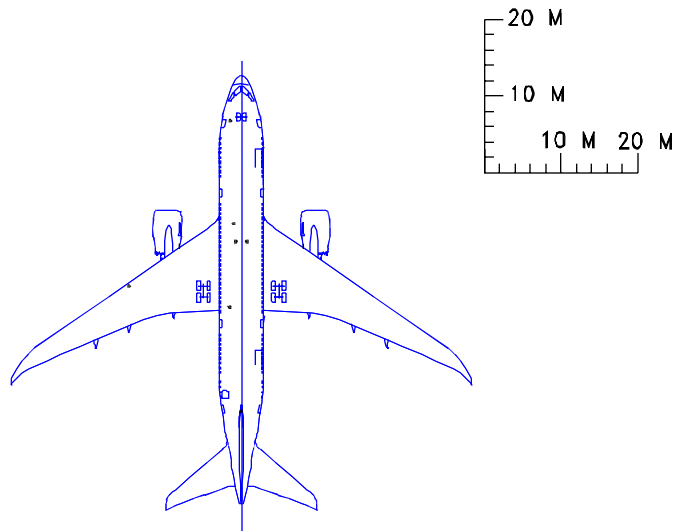

**NOTE: WHEN PRINTING THIS DRAWING, MAKE SURE TO ADJUST FOR PROPER SCALING**

**9.5.2 SCALED DRAWING - 1:1000**  
*MODEL 787-8*

D6-58333