

Recreational Mathematics

Paul Yiu

Department of Mathematics
Florida Atlantic University

Summer 2003

Chapters 1–44

Version 031209

Contents

1	Lattice polygons	101
1.1	Pick's Theorem: area of lattice polygon	102
1.2	Counting primitive triangles	103
1.3	The Farey sequence	104
2	Lattice points	109
2.1	Counting interior points of a lattice triangle	110
2.2	Lattice points on a circle	111
3	Equilateral triangle in a rectangle	117
3.1	Equilateral triangle inscribed in a rectangle	118
3.2	Construction of equilateral triangle inscribed in a rectangle	119
4	Basic geometric constructions	123
4.1	Geometric mean	124
4.2	Harmonic mean	125
4.3	Equal subdivisions of a segment	126
4.4	The Ford circles	127
5	Greatest common divisor	201
5.1	$\gcd(a, b)$ as an integer combination of a and b	202
5.2	Nonnegative integer combinations of a and b	203
5.3	Cassini formula for Fibonacci numbers	204
5.4	\gcd of generalized Fibonacci and Lucas numbers	205
6	Pythagorean triples	209
6.1	Primitive Pythagorean triples	210
6.2	Primitive Pythagorean triangles with square perimeters	211

6.3	Lewis Carroll's conjecture on triples of equiareal Pythagorean triangles	212
6.4	Points at integer distances from the sides of a primitive Pythagorean triangle	213
6.5	Dissecting a rectangle into Pythagorean triangles	214
7	The tangrams	225
7.1	The Chinese tangram	226
7.2	A British tangram	227
7.3	Another British tangram	228
8	The classical triangle centers	231
8.1	The centroid	232
8.2	The circumcircle and the circumcircle	233
8.3	The incenter and the incircle	234
8.4	The orthocenter and the Euler line	235
8.5	The excenters and the excircles	236
9	The area of a triangle	301
9.1	Heron's formula for the area of a triangle	302
9.2	Heron triangles	303
9.3	Heron triangles with consecutive sides	304
10	The golden section	309
10.1	The golden section φ	310
10.2	Dissection of a square	311
10.3	Dissection of a rectangle	313
10.4	The golden right triangle	314
10.5	What is the most non-isosceles triangle?	316
11	Constructions with the golden section	321
11.1	Construction of golden rectangle	322
11.2	Hofstetter's compass-only construction of the golden section	323
11.3	Hofstetter's 5-step division of a segment in the golden section	325
11.4	Construction of regular pentagon	327
11.5	Ahlburg's parsimonious construction of the regular pentagon	328
11.6	Construction of a regular 17-gon	329

12 Cheney's card trick	335
12.1 Principles	336
12.2 Examples	337
13 Digit problems	401
13.1 When can you cancel illegitimately and yet get the correct answer?	402
13.2 A Multiplication problem	403
13.3 A division problem	404
13.4 The most popular Monthly problem	407
13.5 The problem of $4n$'s	408
14 Numbers with many repeating digits	415
14.1 A quick multiplication	416
14.2 The repunits	417
14.3 Squares of repdigits	418
14.4 Sorted numbers with sorted squares	419
15 Digital sum and digital root	423
15.1 Digital sum sequences	424
15.2 Digital root	425
15.3 The digital roots of the powers of 2	426
15.4 Digital root sequences	427
16 3-4-5 triangles in the square	431
17 Combinatorial games	501
17.1 Subtraction games	502
17.1.1 The Sprague-Grundy sequence	503
17.1.2 Subtraction of square numbers	504
17.1.3 Subtraction of square numbers	505
17.2 The nim sum of natural numbers	509
17.3 The game <i>Nim</i>	510
17.4 Northcott's variation of Nim	511
17.5 Wythoff's game	512
18 Repunits	517
18.1 k -right-transposable integers	518
18.2 k -left-transposable integers	519
18.3 Sam Yates' repunit riddles	520

18.4	Recurring decimals	522
18.5	The period length of a prime	523
19	More digital trivia	531
20	The shoemaker's knife	535
20.1	Archimedes' twin circles	536
20.2	Incircle of the shoemaker's knife	537
20.2.1	Archimedes' construction	537
20.2.2	Bankoff's constructions	538
20.2.3	Woo's three constructions	539
20.3	More Archimedean circles	540
21	Infinitude of prime numbers	601
21.1	Proofs by construction of sequence of relatively prime numbers	602
21.2	Somos sequences	603
21.3	Fürstenberg's topological proof made easy	604
22	Strings of prime numbers	611
22.1	The prime number spiral	612
22.2	The prime number spiral beginning with 17	613
22.3	The prime number spiral beginning with 41	614
23	Strings of composites	621
23.1	Strings of consecutive composite numbers	622
23.2	Strings of consecutive composite values of $n^2 + 1$	623
23.3	Consecutive composite values of $x^2 + x + 41$	624
24	Perfect numbers	627
24.1	Perfect numbers	628
24.2	Charles Twigg on the first 10 perfect numbers	629
24.3	Abundant and deficient numbers	630
24.3.1	Appendix: Two enumerations of the rational numbers in (0,1)	633
25	Routh and Ceva theorems	701
25.1	Routh theorem: an example	702
25.2	Routh theorem	703
25.3	Ceva Theorem	704

26 The excircles	711
26.1 Feuerbach theorem	712
26.2 A relation among the radii	713
26.3 The circumcircle of the excentral triangle	714
26.4 The radical circle of the excircles	715
26.5 Apollonius circle: the circular hull of the excircles	716
27 Figurate numbers	719
27.1 Triangular numbers	719
27.2 Special triangular numbers	719
27.3 Pentagonal numbers	721
27.4 The polygonal numbers $P_{n,k}$	722
27.4.1 Appendix: Solution of Pell's equation	723
28 Polygonal triples	725
28.1 Double ruling of \mathcal{S}	726
28.2 Primitive Pythagorean triple associated with a k -gonal triple	727
28.3 Triples of triangular numbers	727
28.4 k -gonal triples determined by a Pythagorean triple	728
28.5 Correspondence between $(2h + 1)$ -gonal and $4h$ -gonal triples	730
29 Sums of consecutive squares	801
29.1 Sum of squares of natural numbers	802
29.2 Sums of consecutive squares: odd number case	803
29.3 Sums of consecutive squares: even number case	805
30 Sums of powers of natural numbers	807
31 A high school mathematics contest	809
32 Mathematical entertainments	817
32.1 2	818
32.2 2	820
33 Maxima and minima without calculus	903
34 A British test of teachers' mathematical background	911

35 A mathematical contest	915
36 Some geometry problems from recent journals	919
37 The Josephus problem and its generalization	1001
37.1 The Josephus problem	1001
37.2 Generalized Josephus problem $\mathcal{J}(n, k)$	1003
38 Permutations	1005
38.1 The universal sequence of permutations	1005
38.2 The position of a permutation in the universal sequence	1007
39 Cycle decompositions	1009
39.1 The disjoint cycle decomposition of a permutation . . .	1009
39.2 2	1010
39.3 Dudeney's Canterbury puzzle 3	1013
39.4 The game of ropes and rungs	1015
40 Graph labelling	1017
40.1 Edge-magic triangle	1017
40.2 Face-magic tetrahedron	1018
40.3 Magic cube	1019
40.4 Edge-magic heptagon	1020
40.5 Edge-magic pentagram	1021
40.6 A perfect magic circle	1022
41 Card tricks from permutations	1101
42 Tetrahedra	1107
42.1 The isosceles tetrahedron	1107
42.2 The volume of an isosceles tetrahedron	1108
42.3 Volume of a tetrahedron	1109
42.4 2	1110
43 Lewis Carroll's unused geometry pillow problem	1113
44 Japanese Temple Geometry	1115

Chapter 1

Lattice polygons

- 1 Pick's Theorem: area of lattice polygon
 - 2 Counting primitive triangles
 - 3 The Farey sequences
- Appendix: Regular solids
Exercise
Project: A cross number puzzle

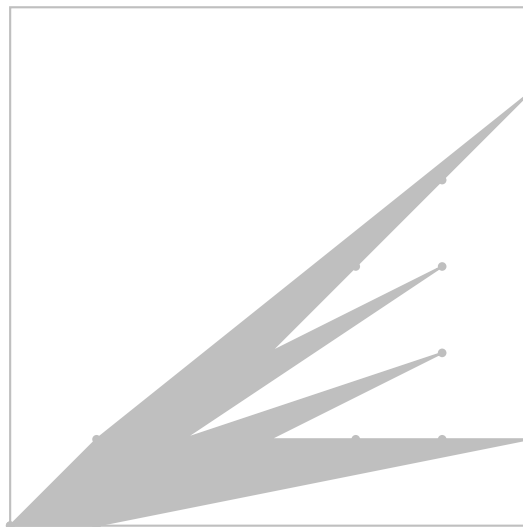

1.1 Pick's Theorem: area of lattice polygon

A lattice point is a point with integer coordinates. A lattice polygon is one whose vertices are lattice points (and whose sides are straight line segments). For a lattice polygon, let

I = the number of interior points, and

B = the number of boundary points.

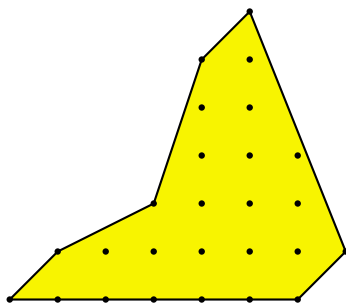

Theorem 1.1 (Pick). *The area of a lattice polygon is $I + \frac{B}{2} - 1$.*

If the polygon is a triangle, there is a simple formula to find its area in terms of the coordinates of its vertices. If the vertices are at the points (x_1, y_1) , (x_2, y_2) , (x_3, y_3) , then the area is ¹

$$\frac{1}{2} \begin{vmatrix} x_1 & y_1 & 1 \\ x_2 & y_2 & 1 \\ x_3 & y_3 & 1 \end{vmatrix}.$$

In particular, if one of the vertices is at the origin $(0, 0)$, and the other two have coordinates (x_1, y_1) , (x_2, y_2) , then the area is $\frac{1}{2}|x_1y_2 - x_2y_1|$.

Given a lattice polygon, we can partition it into *primitive* lattice triangles, *i.e.*, each triangle contains no lattice point apart from its three vertices. Two wonderful things happen that make it easy to find the area of the polygon as given by Pick's theorem.

(1) There are exactly $2I + B - 2$ such primitive lattice triangles no matter how the lattice points are joined. This is an application of Euler's polyhedral formula.

(2) The area of a primitive lattice triangle is always $\frac{1}{2}$. This follows from a study of the Farey sequences.

¹This formula is valid for arbitrary vertices. It is positive if the vertices are traversed counterclockwise, otherwise negative. If it is zero, then the points are collinear.

1.2 Counting primitive triangles

We shall make use of the famous Euler polyhedron formula.

Theorem 1.2. *If a closed polyhedron has V vertices, E edges and F faces, then $V - E + F = 2$.*

Given a lattice polygon with a partition into primitive lattice triangles, we take two identical copies and glue them along their common boundary. Imagine the 2-sheet polygon blown into a closed polyhedron. The number of vertices is $V = 2I + B$. Suppose there are T primitive triangles in each sheet. Then there are $F = 2T$ faces of the polyhedron. Since every face is a triangle, and each edge is contained in exactly two faces, we have $2E = 3F$. It follows that $E = 3T$. Now, Euler's polyhedron formula gives $(2I + B) - 3T + 2T = 2$. From this, we have $T = 2I + B - 2$.

1.3 The Farey sequence

Let n be a positive integer. The Farey sequence of order n is the sequence of rational numbers in $[0, 1]$ of denominators $\leq n$ arranged in increasing order. We write $0 = \frac{0}{1}$ and $1 = \frac{1}{1}$.

$$\begin{aligned}
 \mathcal{F}_1 &: \frac{0}{1}, \frac{1}{1}. \\
 \mathcal{F}_2 &: \frac{0}{1}, \frac{1}{2}, \frac{1}{1}. \\
 \mathcal{F}_3 &: \frac{0}{1}, \frac{1}{3}, \frac{1}{2}, \frac{2}{3}, \frac{1}{1}. \\
 \mathcal{F}_4 &: \frac{0}{1}, \frac{1}{4}, \frac{1}{3}, \frac{1}{2}, \frac{2}{3}, \frac{3}{4}, \frac{1}{1}. \\
 \mathcal{F}_5 &: \frac{0}{1}, \frac{1}{5}, \frac{1}{4}, \frac{1}{3}, \frac{2}{5}, \frac{1}{2}, \frac{3}{5}, \frac{2}{3}, \frac{3}{4}, \frac{4}{5}, \frac{1}{1}. \\
 \mathcal{F}_6 &: \frac{0}{1}, \frac{1}{6}, \frac{1}{5}, \frac{1}{4}, \frac{1}{3}, \frac{2}{5}, \frac{1}{2}, \frac{3}{5}, \frac{2}{3}, \frac{3}{4}, \frac{4}{5}, \frac{5}{6}, \frac{1}{1}. \\
 \mathcal{F}_7 &: \frac{0}{1}, \frac{1}{7}, \frac{1}{6}, \frac{1}{5}, \frac{1}{4}, \frac{2}{7}, \frac{1}{3}, \frac{3}{7}, \frac{2}{5}, \frac{3}{4}, \frac{4}{5}, \frac{5}{7}, \frac{2}{3}, \frac{3}{5}, \frac{4}{7}, \frac{6}{7}, \frac{1}{1}.
 \end{aligned}$$

Theorem 1.3. 1. If $\frac{h}{k}$ and $\frac{h'}{k'}$ are successive terms of \mathcal{F}_n , then

$$kh' - hk' = 1 \quad \text{and} \quad k + k' > n.$$

2. If $\frac{h}{k}$, $\frac{h'}{k'}$, and $\frac{h''}{k''}$ are three successive terms of \mathcal{F}_n , then

$$\frac{h'}{k'} = \frac{h + h''}{k + k''}.$$

The rational numbers in $[0, 1]$ can be represented by lattice points in the first quadrant (below the line $y = x$). Restricting to the left side of the vertical line $x = n$, we can record the successive terms of the Farey sequence \mathcal{F}_n by rotating a ruler about 0 counterclockwise from the positive x -axis. The sequence of “visible” lattice points swept through corresponds to \mathcal{F}_n . If P and Q are two lattice points such that triangle OPQ contains no other lattice points in its interior or boundary, then the rational numbers corresponding to P and Q are successive terms in a Farey sequence (of order \leq their denominators).

Corollary 1.4. A primitive lattice triangle has area $\frac{1}{2}$.

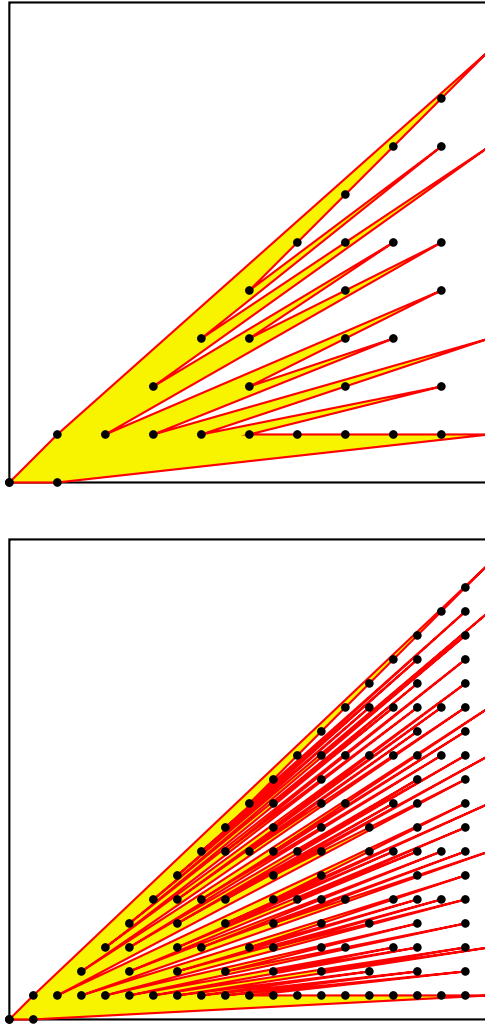
The Farey polygons \mathcal{P}_{10} and \mathcal{P}_{20} 

Let $\phi(n)$ be the number of integers m satisfying $1 \leq m \leq n$ and $\gcd(m, n) = 1$. The Farey sequence \mathcal{F}_n has $1 + \sum_{k=1}^n \phi(k)$ terms. The polygon \mathcal{P}_n contains $2 + \sum_{k=1}^n \phi(k)$ boundary points and no interior points. By Pick's formula, its area is $A_n = \frac{1}{2} \sum_{k=1}^n \phi(k)$. By a calculation of D. N. Lehmer [Lehmer], for large values of n , this area is about $\frac{3}{2\pi^2}$ of the (smallest) square containing it:

$$\lim_{n \rightarrow \infty} \frac{A_n}{n^2} = \frac{3}{2\pi^2}.$$

Appendix: Regular solids

A regular solid is one whose faces of regular polygons of the same type, say, n -gons, and each vertex belongs to the same number of faces, say, m faces. Note that $m \geq 3$ and $n \geq 3$.

Let V , E , and F be the numbers of vertices, edges, and faces respectively. Then $nF = 2E = mV$, and $V = \frac{2E}{m}$, $F = \frac{2E}{n}$. Since $V - E + F = 2$, we have $\frac{2E}{m} - E + \frac{2E}{n} = 2$. From this,

$$E = \frac{2mn}{2(m+n) - mn}.$$

Since $m, n \geq 3$, and we require $2(m+n) > mn$, the only possibilities are as follows.

m	n	E	$V = \frac{2E}{m}$	$F = \frac{2E}{n}$	regular solid
3	3				tetrahedron
3	4				cube
3	5				duodecahedron
4	3				octahedron
5	3				icosahedron

Exercise

1. Can a lattice triangle be equilateral? Why?
2. Can a lattice polygon be regular? Why? [You may make use of the nontrivial fact that *the only values of n for which $\sin \frac{\pi}{n}$ is rational is $n = 6$.*]
3. For $B = 3, 4, 6, 8, 9$, give an example of a lattice triangle with exactly one interior point and B boundary points.²
4. Give an example of an equilateral lattice hexagon.
5. How many terms does the Farey sequence \mathcal{F}_n have? [Hint: Give the answer in terms of the Euler φ -function].
6. The Farey polygon \mathcal{P}_n is the lattice polygon whose vertices, taken in order, are the origin and the points (k, h) for $\frac{h}{k}$ in the Farey sequence \mathcal{F}_n . Here is \mathcal{P}_6 .

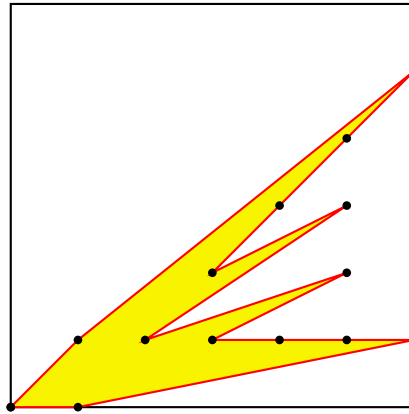

Find the area of \mathcal{P}_6 and that of \mathcal{P}_n for a general n .

²In [Weaver], it is shown that these are the only possible values of B if $I = 1$.

A cross number puzzle

1	2	3		4	5	6	7	
8				9				10
11			12			13		
		14		15	16		17	
	18					19		
20			21					
22		23			24		25	26
27			28	29		30		
	31					32		

Across

- 1 A perfect square
 4 A palindromic integer
 8 This many degrees Fahrenheit is 265 degrees Centigrade
 9 With 3-down, a permutation of the digits 0 through 9
 11 Second smallest prime of the form $n^2 + 2^n + 1$, $n > 0$
 13 A gross number
 14 19-down minus 18-down plus 26-down
 17 Number of 2-digit primes
 18 The product of the digits of this number is 78125
 20 The sum of this number's positive divisors is 91
 21 $33^2 + 3^2$
 22 This number is the sum of the factorials of its digits
 24 A power of 6
 27 The sum of the fourth power of 5 consecutive triangular numbers
 30 A Mersenne prime
 31 A power of 2
 32 The number of the beast

Down

- 1 A multiple of 11
 2 The product of the positive divisors of the number is 202^2
 3 See 9-across
 4 A Fermat prime
 5 Product of the first 3 primes
 6 Colleague of 1-across
 7 In base 2, this number is written 11010001110001
 10 Yet another perfect square!
 12 The first prime year after 1950
 15 This many degrees is $\frac{25}{6}\pi$ radians
 16 The 17th Fibonacci number
 18 $210^2 + 111^2$
 19 The least common multiple of 36 and 1631
 20 The number of positive perfect squares less than 10^5
 23 The number of positive integers less than 625 which are not divisible by 5
 25 The sum of these digits is 15, and their product is 84
 26 Palindromic square
 28 The only even prime number
 29 20-across minus 28-down

Chapter 2

Lattice points

- 1 Counting interior points of a lattice triangle
- 2 Lattice points on a circle
 - Appendix: The floor and the ceiling
 - Appendix: Number of lattice points in a circle
 - Appendix: Number of lattice points under a hyperbola
 - Exercise
 - Project: Cross number puzzle

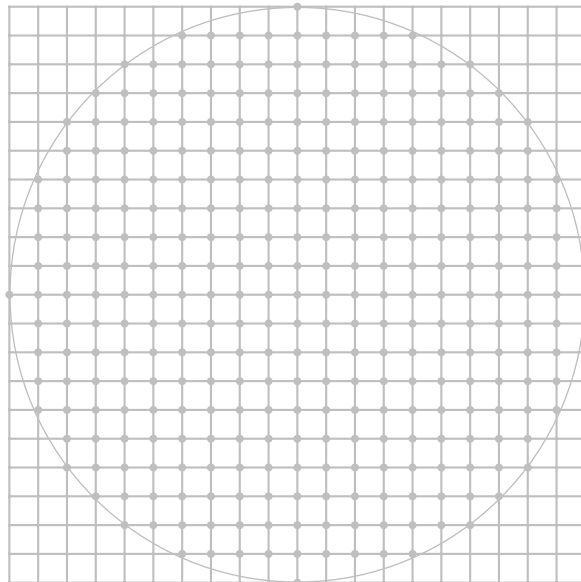

2.1 Counting interior points of a lattice triangle

A lattice triangle has vertices at $(0, 0)$, $(a, 0)$, and (a, b) .

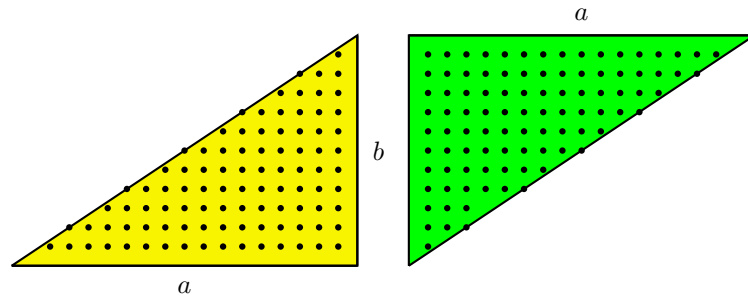

Counting in two ways, we obtain as

$$\sum_{n=1}^{a-1} \left\lfloor \frac{nb}{a} \right\rfloor = \sum_{m=1}^{b-1} \left\lfloor \frac{ma}{b} \right\rfloor.$$

Note that each of these is the total number of interior points and those on the hypotenuse (except the two vertices). There are $\gcd(a, b) - 1$ points in the latter group.

If we put these two copies together to form a rectangle, we see that the interior points along the diagonal are counted twice. Since the rectangle has $(a - 1)(b - 1)$ interior points, we have exactly

$$\frac{(a - 1)(b - 1) - \gcd(a, b) + 1}{2}$$

lattice points in the interior of the triangle.

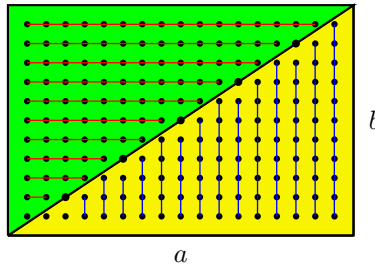

In particular, if $\gcd(a, b) = 1$, then the triangle has $\frac{1}{2}(a - 1)(b - 1)$ interior points.

Note that we have an algorithm for computing the gcd of two integers:

$$\gcd(a, b) = 2 \sum_{m=1}^{b-1} \left\lfloor \frac{ma}{b} \right\rfloor - (a - 1)(b - 1) + 1.$$

2.2 Lattice points on a circle

How many lattice points are there on the circle $x^2 + y^2 = n^2$? This number is usually denoted by $r_2(n^2)$. The first few values can be read from the following figure.

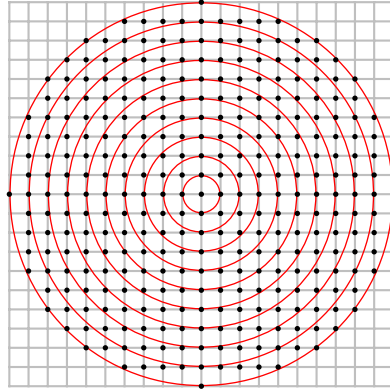

n	1	2	3	4	5	6	7	8	9	10
$r_2(n^2)$										

In general, if the number n is factored into a product of prime powers

$$n = 2^a \cdot \prod_i p_i^{b_i} \cdot \prod_j q_j^{c_j},$$

where p_i and q_j are prime numbers of the forms $4k + 1$ and $4k + 3$ respectively, then

$$r_2(n^2) = 4 \prod_i (2b_i + 1).$$

Thus, for example, the circle of radius 100 has ____ lattice points. On the other hand, if p is a prime number of the form $4n + 1$, then the circle of radius p has 12 lattice points. Four of these are on the coordinate axes. The other 8 are of the form $(\pm a, \pm b)$, $(\pm b, \pm a)$, and depend on how the prime p is written as a sum of two squares.

Appendix: The floor and the ceiling

The *floor* of a real number x is the greatest integer not exceeding x :¹

$$\lfloor x \rfloor := \max\{n \in \mathbb{Z} : n \leq x\}.$$

On the other hand, the *ceiling* of x is the least integer not exceeded by x :

$$\lceil x \rceil := \min\{n \in \mathbb{Z} : n \geq x\}.$$

If x is not a half-integer, we denote by $\{x\}$ the integer *nearest* x .

Project

Find all integers n for which $\lfloor \sqrt{n} \rfloor$ divides n .

How about $\lceil \sqrt{n} \rceil$ dividing n ?

¹It is sometimes called the greatest integer function of x and denoted by $[x]$.

Appendix: Number of lattice points inside a circle

Given a real number r , how many lattice points are there inside or on the circle of radius r , center at the origin?

Write a computer program to find out exactly how many lattice points are inside or on the circle radius 100.

For large values of R , the number $K(R)$ of lattice points inside and on the circle of radius \sqrt{R} satisfies

$$\pi R - \pi(2\sqrt{2}\sqrt{R} - 2) < K(R) < \pi R + \pi(2\sqrt{2}\sqrt{R} + 2).$$

This is often expressed by writing

$$K(R) = \pi R + O(\sqrt{R}).$$

Appendix: Number of lattice points under a hyperbola

Given a real number R , how many lattice points in the first quadrant are under the hyperbola $xy = R$ (but not on the axes)?

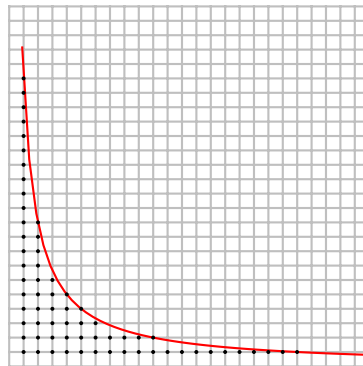

This number is

$$H(R) = \sum_{1 \leq n \leq \lfloor R \rfloor} d(n).$$

As a crude estimate, $H(R) = R \log R + O(R)$. A better estimate was given by Dirichlet

$$H(R) = R \log R + (2\gamma - 1)R + O(\sqrt{R}).$$

Here, γ is the Euler constant

$$\lim_{n \rightarrow \infty} \left(1 + \frac{1}{2} + \frac{1}{3} + \cdots + \frac{1}{n} \right) - \log n \approx 0.5772157 \dots$$

Exercise

1. Consider the lattice triangle ABC with $A = (0, 0)$, $B = (36, 15)$ and $C = (16, 30)$. Calculate the lengths of the sides of the triangle. What is the area of the triangle? How many boundary and interior points does it have?
2. Repeat the same for the lattice triangle ABC with $A = (0, 0)$, $B = (24, 45)$ and $C = (48, 55)$.
3. Give an example of a lattice triangle whose side lengths are 13, 14, 15. What is the area? How many interior and boundary points does the triangle have?
4. There is a list of n statements. For $k = 1, 2, \dots, n$, the k -th statement reads:

The number of false statements in this list is greater than k .

Determine the truth value of each of these statements.

5. Solve the equation

$$\left\lfloor \frac{x+1}{2} \right\rfloor \left\lfloor \frac{x+2}{3} \right\rfloor \left\lfloor \frac{x+3}{4} \right\rfloor = 819.$$

6. Write 97 as a sum of 2 squares and find the lattice points on the circle of radius 97.

Project: Cross number puzzle

Fill in the accompanying square with distinct 2-, 3-, and 4-digit numbers which are perfect squares, none of which begins with 0.

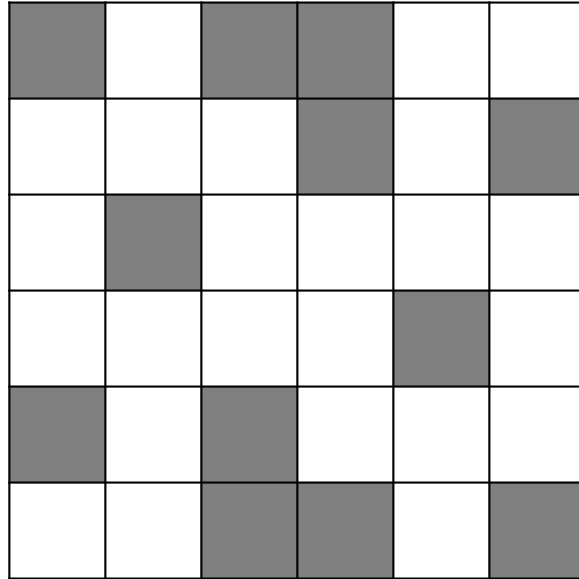

Chapter 3

Equilateral triangle in a rectangle

- 1 Equilateral triangle inscribed in a rectangle
- 2 Construction
Exercise

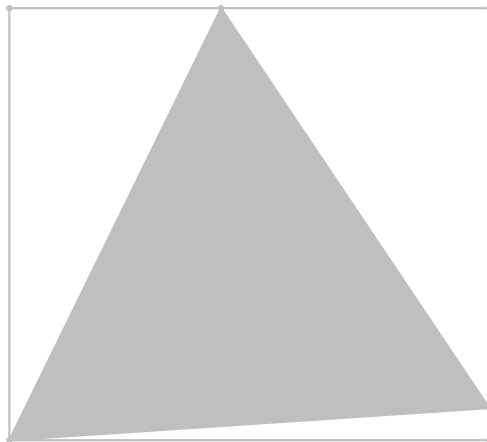

3.1 Equilateral triangle inscribed in a rectangle

Given a rectangle $ABCD$, how can we choose a point P on BC and a point Q on CD such that triangle APQ is equilateral?

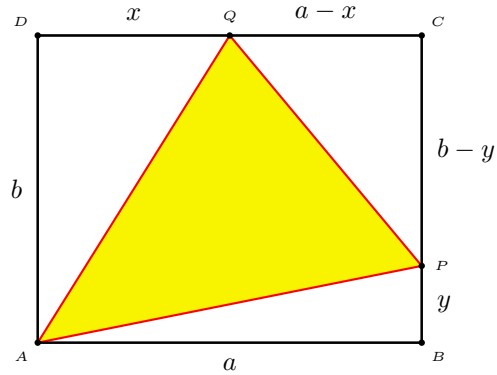

Suppose $AB = DC = a$, $BC = AD = b$, $DQ = x$, and $BP = y$. These satisfy

$$a^2 + y^2 = b^2 + x^2 = (a - x)^2 + (b - y)^2.$$

From these, $2(ax + by) = a^2 + y^2 = b^2 + x^2$, and we have

$$(x^2 - 2ax + b^2)^2 = 4b^2(b^2 + x^2) - 4a^2b^2.$$

This can be rewritten as

$$(x^2 + b^2)((x^2 + b^2) - 4ax - 4b^2) = 0,$$

from which

$$x = 2a - \sqrt{3}b.$$

Similarly, $y = 2b - \sqrt{3}a$.

3.2 Construction of equilateral triangle inscribed in a rectangle

What is more interesting is that the above calculation leads to a very easy construction of the equilateral triangle AXY .

Construction 3.1. Construct equilateral triangles BCY and CDX so that X and Y are in the interior of the rectangle. ¹ Join AX to intersect BC at P and AY to intersect CD at Q . Then AXY is equilateral.

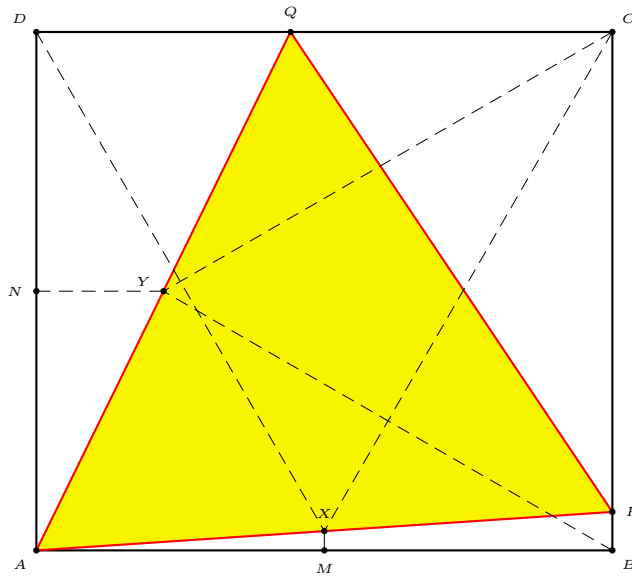

¹This is not always possible. What is the range of the ratio $\frac{a}{b}$ for X and Y to be in the interior of the rectangle?

Exercise

1. Show that $\text{Area}(ABP) + \text{Area}(ADQ) = \text{Area}(CPQ)$.

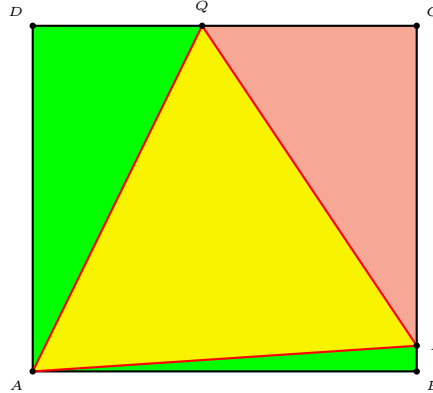

2. Take a 9×10 rectangle $ABCD$ and obtain the equilateral triangle APQ by **folding**.
3. P is a point in the interior of a rectangle $ABCD$. Suppose $AP = a$, $BP = b$, $CP = c$. Find the distance DP in terms of a, b, c .

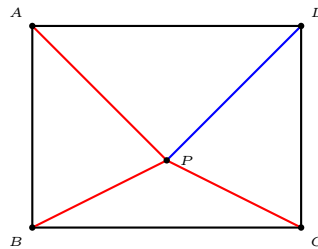

4. A pavement of width d is constructed across a rectangular field of dimensions a by b . What is the area of the pavement?

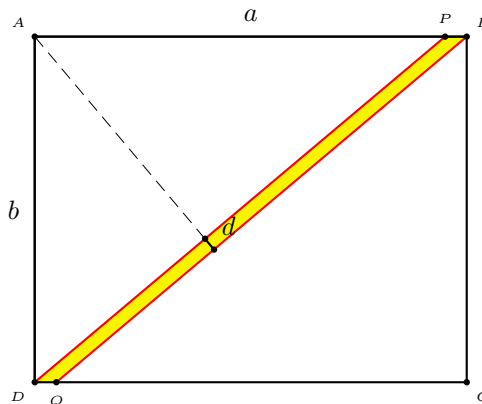

5. A piece of 8×11 paper is to be cut into a pattern that can be folded into a cube. Find the largest cube that can be obtained, and the percentage of the paper wasted.

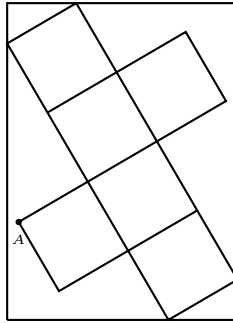

6. What is the length of the paper if the corner A is on the edge, and the width is 8 units?

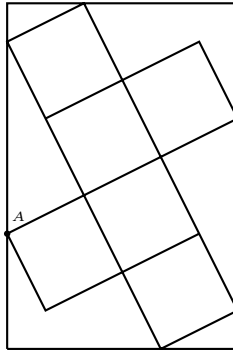

Chapter 4

Basic geometric constructions

- 1 Geometric mean
 - 2 Harmonic mean
 - 3 Equal subdivisions of a segment
 - 4 The Ford circles
- Appendix: Some basic construction principles
Appendix: The Geometer's Sketchpad
Exercise

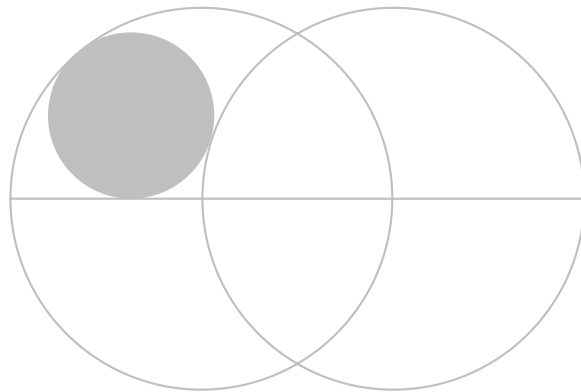

4.1 Geometric mean

We present two ruler-and-compass constructions of the geometric means of two quantities given as lengths of segments. These are based on Euclid's proof of the Pythagorean theorem.

Construction 4.1. Given two segments of length $a < b$, mark three points P, A, B on a line such that $PA = a$, $PB = b$, and A, B are on the *same* side of P . Describe a semicircle with PB as diameter, and let the perpendicular through A intersect the semicircle at Q . Then $PQ^2 = PA \cdot PB$, so that the length of PQ is the geometric mean of a and b .

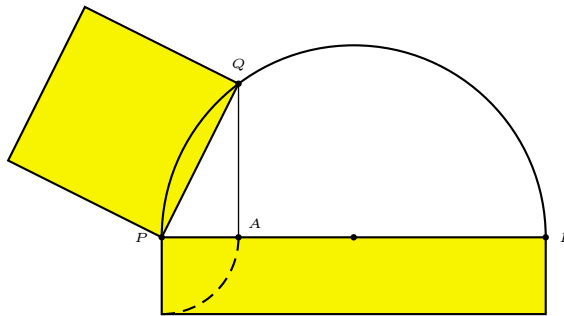

Construction 4.2. Given two segments of length a, b , mark three points A, P, B on a line (P between A and B) such that $PA = a$, $PB = b$. Describe a semicircle with AB as diameter, and let the perpendicular through P intersect the semicircle at Q . Then $PQ^2 = PA \cdot PB$, so that the length of PQ is the geometric mean of a and b .

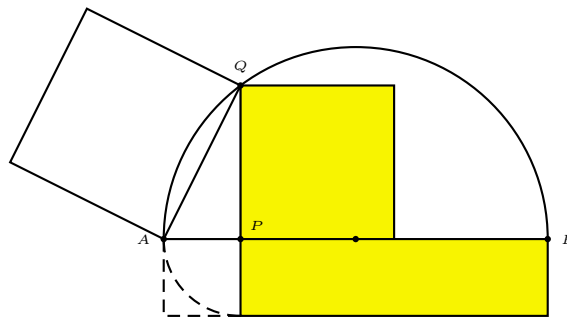

4.2 Harmonic mean

Let $ABCD$ be a trapezoid with $AB \parallel CD$. If the diagonals AC and BD intersect at K , and the line through K parallel to AB intersect AD and BC at P and Q respectively, then PQ is the harmonic mean of AB and CD :

$$\frac{2}{PQ} = \frac{1}{AB} + \frac{1}{CD}.$$

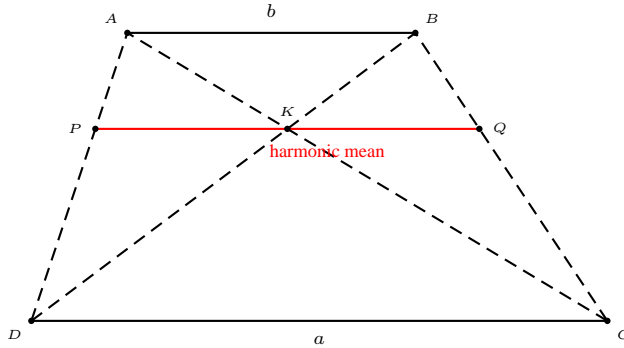

Another construction

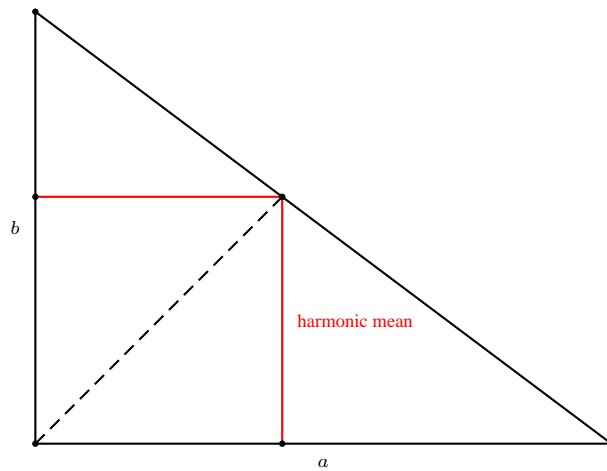

4.3 Equal subdivisions of a segment

Here is an algorithm to divide a given segment into $n < 2^{k+1}$ equal parts, making use of the binary representation of n , which contains not more than $k + 1$ digits.

Construct a square $ABCD$ on the given segment. By repeated bisections of CD , introduce the points C_1, C_2, \dots, C_k such that

$$DC_i = \frac{1}{2^i} DC, \quad i = 1, 2, \dots, k.$$

We also put $C_0 = C$.

Let $n < 2^{k+1}$. Its binary representation has no more than $k + 1$ digits. Suppose it has $m + 1$ nonzero binary digits.

Along the direction CD , relabel those points corresponding to the *nonzero* digits, as Q_0, Q_1, \dots, Q_m .¹

Let P_0 be the (orthogonal) projection of Q_0 on AB .

For each $j = 1, \dots, m$, construct the segments $P_{j-1}D$ and AQ_j , and mark the projection of their intersection on AB as the point P_j .

Then P_m is the point which divides AB into n equal parts.

Here is the case for $n = 13$ with binary representation 1101_2 .

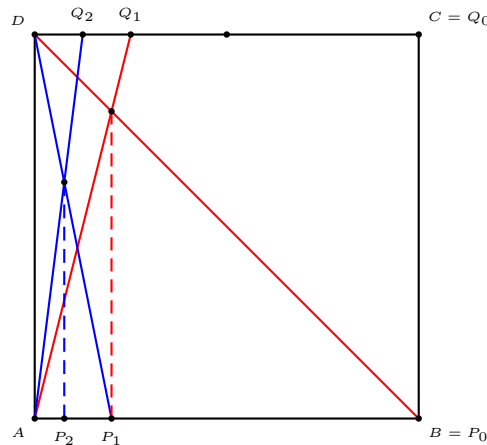

It would be interesting if this procedure can be modified to give a simple construction of subdivision points with ratio $m : n$ instead of $1 : n$.

¹For example, if $n = 13$, which has binary representation 1101_2 , we relabel C_0 as Q_0 , C_2 as Q_1 , and C_4 as Q_2 .

4.4 The Ford circles

The Ford circle of a rational number $r = \frac{p}{q}$ is the circle of radius $\frac{1}{2q^2}$ in the upper half plane tangent to the x -axis at the point $(r, 0)$.

The Ford circles of two distinct rational numbers are either disjoint or tangent to each other externally. In the latter case we say that two rational numbers are *adjacent*.

Theorem 4.1. *Two rational numbers are adjacent if and only if they are consecutive terms in a Farey sequence.*

Corresponding to each Farey sequence, there is a sequence of tangent Ford circles. Here are the Ford circles corresponding to \mathcal{F}_5 .

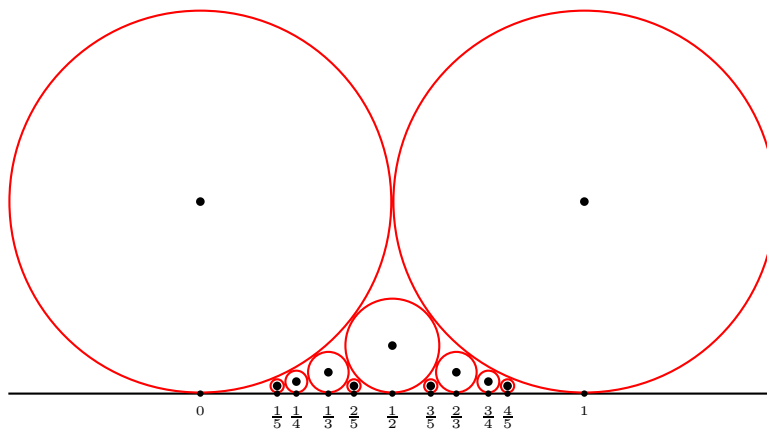

Exercise

1. If $\frac{p}{q}$ and $\frac{P}{Q}$ are adjacent rational numbers, what is the point of tangency of their Ford circles?

Appendix: Some basic construction principles

Theorem 4.2 (Perpendicular bisector locus). *Given two distinct A and B on a plane, a point P is equidistant from A and B if and only if P lies on the perpendicular bisector of the segment AB .*

Theorem 4.3 (Angle bisector locus). *A point P is equidistant from two given intersecting lines if and only if it lies on the bisector of an angle between the two lines.*

Note that two intersecting lines have two angle bisectors.

Theorem 4.4. *If two circles are tangent to each other, the line joining their centers passes through the point of tangency.*

The distance between their centers is the sum (respectively difference) of their radii if the tangency is external (respectively internal).

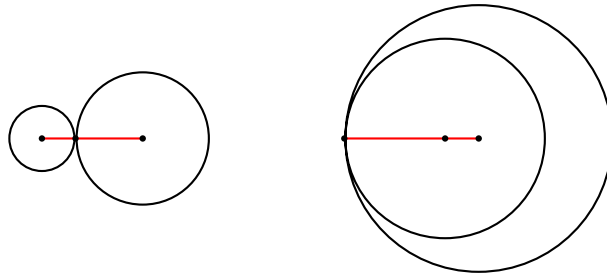

The Geometer's Sketchpad

Basic commands

- Construct points, segments, lines, circles.
- Construct a segment, ray, or line through two specified points.
- Construct a circle given its center and a point on it. Construct a circle given its center and radius.
- Construct the intersection of two objects.
- Construct the midpoint of a segment.
- Given a line ℓ and a point P , construct lines perpendicular and parallel to ℓ through P .
- Translate, rotate, and dilate.
- Hide an object. (If the sketch you are making becomes too complicated, you may wish to hide some of the objects to make it simpler. Note that this is *not* the same as “delete”).
- Label an object. Change the name of the object.
- Save a Sketch.
- Create New Tool.

Toolbox

Open a new sketch. Select a segment and build an equilateral triangle on it. Hide everything except the vertices and sides of the equilateral triangle. Select everything by dragging the mouse from top left to bottom right. Select **Create New Tool**, and type a name for the tool, say, **equilateral triangle**. A new tool will now appear.

Save this as a file **basic shapes.gsp** in the folder **tool folder**.

From the **File** menu, choose **Document options, Add page, Blank page**. On this blank page, construct a square on a segment. Select **Create new tool** and name this **square**. Save the file.

You can extend this **basic shapes.gsp** tool by opening new blank pages and creating new tools. Remember to **save** the file.

The current **basic shape.gsp** file contains the following tools: equilateral triangle, square, rectangle, right triangle, parallelogram, rhombus. You may of course add your own tools to the same file.

Exercise

1. Given triangle ABC , construct the equilateral triangles BCX , CAY and ABZ externally on the sides of the triangle. Join AX , BY , CZ . What can you say about the intersections, lengths, and directions of these lines (segments)?
2. Show that the 90° angle of a right triangle is bisected by the line joining it to the center of the square on the hypotenuse.
3. Make a sketch to show that for two given positive quantities a and b ,

$$\frac{a+b}{2} \geq \sqrt{ab} \geq \frac{2ab}{a+b}.$$

4. Construct the following diagram.

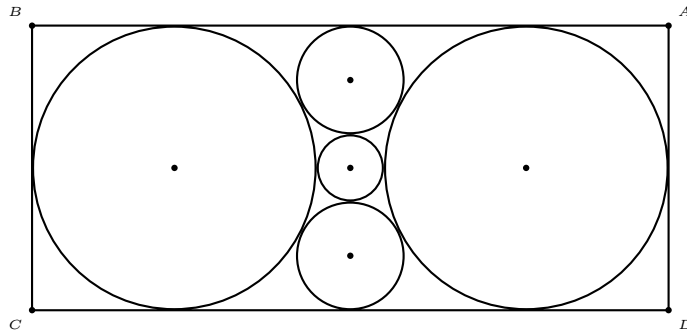

5. Construct the following diagram.

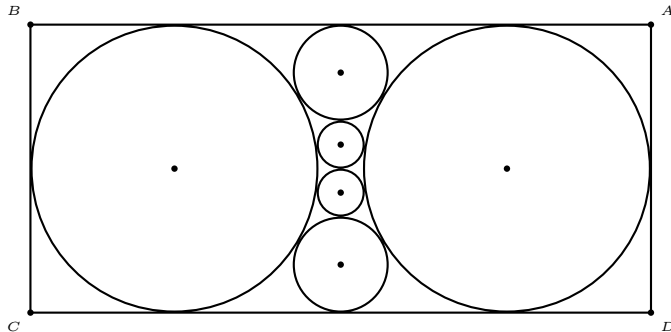

6. Two congruent circles of radii a have their centers on each other. Consider the circle tangent to one of them internally, the other externally, and the line joining their centers. It is known that this circle has radius $\frac{\sqrt{3}}{4}a$. Construct the circle.

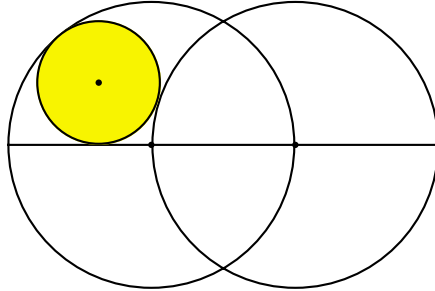

7. An equilateral triangle of side $2a$ is partitioned symmetrically into a quadrilateral, an isosceles triangle, and two other congruent triangles. If the inradii of the quadrilateral and the isosceles triangle are equal, the common inradius is $(\sqrt{3} - \sqrt{2})a$. Construct the partition.

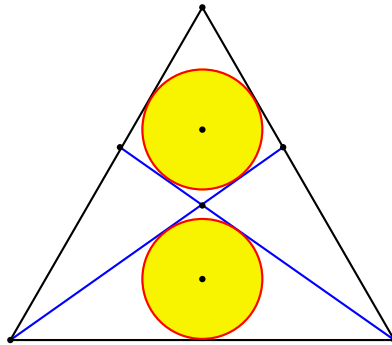

8. Outline a simple procedure to divide a segment into 123 equal parts.

Chapter 5

Greatest common divisor

- 1 $\gcd(a, b)$ as an integer combination of a and b
 - 2 Nonnegative integer combinations of a and b
 - 3 Cassini formula for Fibonacci numbers
 - 4 \gcd of generalized Fibonacci and Lucas numbers
- Appendix: The Euler ϕ -function
 Exercise
 Project

k	r_k	q_k	x_k	y_k
-1	F_{n+1}	***	1	0
0	F_n	1	0	1
1	F_{n-1}	1	F_1	$-F_2$
2	F_{n-2}	1	$-F_2$	F_3
3	F_{n-3}	1	F_3	$-F_4$
\vdots				
$n-3$	F_3	1	$(-1)^{n-2}F_{n-3}$	$(-1)^{n-1}F_{n-2}$
$n-2$	F_2	1	$(-1)^{n-1}F_{n-2}$	$(-1)^nF_{n-1}$
$n-1$	F_1	1	$(-1)^nF_{n-1}$	$(-1)^{n+1}F_n$
n	0	***		

5.1 $\gcd(a, b)$ as an integer combination of a and b

It is well known that the gcd of two (positive) integers a and b can be calculated efficiently by repeated divisions. Assume $a > b$. We form two sequences r_k and q_k as follows. Beginning with $r_{-1} = a$ and $r_0 = b$, for $k \geq 0$, let

$$q_k = \left\lfloor \frac{r_{k-1}}{r_k} \right\rfloor, \quad r_{k+1} = \text{mod}(r_{k-1}, r_k) := r_{k-1} - q_k r_k.$$

These divisions eventually terminate when some r_n divides r_{n-1} . In that case, $\gcd(a, b) = r_n$.

If, along with these divisions, we introduce two more sequences (x_k) and (y_k) with the same rule but specific initial values, namely,

$$\begin{aligned} x_{k+1} &= x_{k-1} - q_k x_k, & x_{-1} &= 1, & x_0 &= 0; \\ y_{k+1} &= y_{k-1} - q_k y_k, & y_{-1} &= 0, & y_0 &= 1. \end{aligned}$$

then we obtain $\gcd(a, b)$ as an integer combination of a and b :¹

$$\gcd(a, b) = r_n = ax_n + by_n.$$

k	r_k	q_k	x_k	y_k
-1	a	***	1	0
0	b	$\lfloor \frac{a}{b} \rfloor$	0	1
1	$a - \lfloor \frac{a}{b} \rfloor b$	$\lfloor \frac{b}{r_1} \rfloor$	x_1	y_1
\vdots				
$n-1$	r_{n-1}	q_{n-1}	x_{n-1}	y_{n-1}
n	r_n	q_n	x_n	y_n
$n+1$	0			

It can be proved that $|x_n| < b$ and $|y_n| < a$.

Theorem 5.1. *Given relatively prime integers $a > b$, there are unique integers $h, k < a$ such that $ak - bh = 1$.*

Proof. Clearly, x_n and y_n are opposite in sign. Take $(k, h) = (x_n, -y_n)$ or $(b + x_n, a - y_n)$ according as $x_n > 0$ or < 0 . \square

Corollary 5.2. *Let p be a prime number. For every integer a not divisible by p , there exists a positive integer $b < p$ such that $ab - 1$ is divisible by p .*

¹In each of these steps, $r_k = ax_k + by_k$.

5.2 Nonnegative integer combinations of a and b

Find the *largest* positive integer which *cannot* be written as $7x + 11y$ for integers $x, y \geq 0$.

Let $S := \{7x + 11y : x, y \text{ nonnegative integers}\}$. Arrange the positive integers in the form

1	8	15	22*	29	36	43	50	57	64	71	...
2	9	16	23	30	37	44*	51	58	65	72	...
3	10	17	24	31	38	45	52	59	66*	73	...
4	11*	18	25	32	39	46	53	60	67	74	...
5	12	19	26	33*	40	47	54	61	68	75	...
6	13	20	27	34	41	48	55*	62	69	76	...
7	14	15	28	35	42	49	56	63	70	77	...

Observations: (i) Every number in the bottom row, being a positive multiple of 7, is in S .

(ii) Among the first 11 columns, along each of the first 6 rows, there is a unique entry (with asterisk) which is a multiple of 11. This entry with asterisk, and those on its right along the row, are in S .

(iii) None of the entries on the left of an entry with asterisk is in S .

(iv) The entries with asterisks are on different columns.

(v) The rightmost entry with an asterisk is 66. From this, the *largest* integer *not* in S is $66 - 7 = 59$.

Theorem 5.3. *Let a and b be given relatively prime positive integers. Every integer greater than $ab - a - b$ can be written as $ax + by$ for nonnegative integers x and y .*

Proof. Let $S := \{ax + by : x, y \text{ nonnegative integers}\}$.

Suppose, for a contradiction, $ab - a - b = ax + by$, $x, y \geq 0$. Then $ab = a(x + 1) + b(y + 1)$. Note that $a \nmid b(y + 1)$. Since $\gcd(a, b) = 1$, we must have $a \mid y + 1$. But $y + 1$ is a positive integer *smaller* than a . This is clearly a contradiction. From this $ab - a - b \notin S$.

Every integer t in the range $0 < t < a$ can be written as $t = au - bv$ for $0 < u < b$ and $0 \leq v < a$. (Choose $u \in \{1, 2, \dots, b - 1\}$ such that $au \equiv t \pmod{b}$). Then $0 < au - t < ab$. It follows that $au - t = bv$ for some $1 \leq v < a$. Thus, every positive integer $< a + b$ is of the form $au - bv$, $0 < u < b$, $0 \leq v < a$. Suppose $(a - 1)(b - 1) \leq n < ab$. Then $ab - n < a + b$. Write $ab - n = au - bv$ for $0 < u < b$ and $0 \leq v < a$. From this, $n = a(b - u) + bv$. This shows that $n \in S$. \square

5.3 Cassini formula for Fibonacci numbers

The Fibonacci numbers F_n are defined recursively by

$$F_{n+1} = F_n + F_{n-1}, \quad F_0 = 0, F_1 = 1.$$

The first few Fibonacci numbers are

n	0	1	2	3	4	5	6	7	8	9	10	11	12	...
F_n	0	1	1	2	3	5	8	13	21	34	55	89	144	...

It is easy to see that

$$\begin{aligned} \gcd(F_{n+1}, F_n) &= \gcd(F_n, F_{n-1}) \\ &= \gcd(F_{n-1}, F_{n-2}) \\ &\vdots \\ &= \gcd(F_2, F_1) = 1. \end{aligned}$$

However, following the euclidean algorithm, we obtain the Cassini formula

$$F_{n+1}F_{n-1} - F_n^2 = (-1)^n.$$

k	r_k	q_k	x_k	y_k
-1	F_{n+1}	***	1	0
0	F_n	1	0	1
1	F_{n-1}	1	F_1	$-F_2$
2	F_{n-2}	1	$-F_2$	F_3
3	F_{n-3}	1	F_3	$-F_4$
\vdots				
$n-3$	F_3	1	$(-1)^{n-2}F_{n-3}$	$(-1)^{n-1}F_{n-2}$
$n-2$	F_2	1	$(-1)^{n-1}F_{n-2}$	$(-1)^nF_{n-1}$
$n-1$	F_1	1	$(-1)^nF_{n-1}$	$(-1)^{n+1}F_n$
n	0	***		

5.4 gcd of generalized Fibonacci and Lucas numbers

Given a and b , the generalized Fibonacci sequence $\mathcal{F}(a, b)$

$$F_{n+1} = aF_n + bF_{n-1}, \quad F_0 = 0, F_1 = 1.$$

There is also an accompanying Lucas sequence $\mathcal{L}(a, b)$

$$L_{n+1} = aL_n + bF_{n-1}, \quad L_0 = 2, L_1 = a.$$

Theorem 5.4. *Let a and b be relatively prime integers. The associated Fibonacci and Lucas sequences satisfy*

$$\gcd(u_m, u_n) = u_{\gcd(m,n)}.$$

Examples

(a, b)	$F_n^{(a,b)}$	$L_n^{(a,b)}$	Lucas
$(1, 1)$	F_n Fibonacci	L_n	Lucas
$(1, -1)$	periodic		periodic
$(2, -1)$	n natural	2	constant
$(3, -2)$	$2^n - 1$ Mersenne	$2^n + 1$	Fermat
$(11, -10)$	1_n repunits	$10_{k-1}1$	

Corollary 5.5. 1. $\gcd(2^m - 1, 2^n - 1) = 2^{\gcd(m,n)} - 1$.

2. $\gcd(F_m, F_n) = F_{\gcd(m,n)}$.

3. $\gcd(1_m, 1_n) = 1_{\gcd(m,n)}$.

Exercise

1. Find the gcd of the following pairs of numbers by completing the second column of each table.

Express the gcd as an integer combination of the given numbers by completing the last two columns.

r_k	q_k	x_k	y_k
54321	* * *	1	0
12345		0	1

r_k	q_k	x_k	y_k
267914296	* * *	1	0
196418		0	1

2. Find the immediate neighbors of $\frac{13}{31}$ in \mathcal{F}_{31} .
3. Find the immediate neighbors of the fraction $\frac{1}{2}$ in the Farey sequence \mathcal{F}_n .
4. Somebody received a check, calling for a certain amount of money in dollars and cents. When he went to cash the check, the teller made a mistake and paid him the amount which was written as cents, in dollars, and vice versa. Later, after spending \$ 3.50, he suddenly realized that he had twice the amount of the money the check called for. What was the amount on the check ?

Project

Generalize

$$3 + \frac{3}{2} = 3 \times \frac{3}{2}.$$

$$\begin{aligned} & 3 + \frac{3}{2} + \frac{9}{7} \\ &= 3 \times \frac{3}{2} + \frac{9}{7} \\ &= 3 \times \frac{3}{2} \times \frac{9}{7}. \end{aligned}$$

$$\begin{aligned} & 3 + \frac{3}{2} + \frac{9}{7} + \frac{81}{67} \\ &= 3 \times \frac{3}{2} + \frac{9}{7} + \frac{81}{67} \\ &= 3 \times \frac{3}{2} \times \frac{9}{7} + \frac{81}{67} \\ &= 3 \times \frac{3}{2} \times \frac{9}{7} \times \frac{81}{67} \end{aligned}$$

$$\begin{aligned} & 3 + \frac{3}{2} + \frac{9}{7} + \frac{81}{67} + \frac{6561}{5623} \\ &= 3 \times \frac{3}{2} + \frac{9}{7} + \frac{81}{67} + \frac{6561}{5623} \\ &= 3 \times \frac{3}{2} \times \frac{9}{7} + \frac{81}{67} + \frac{6561}{5623} \\ &= 3 \times \frac{3}{2} \times \frac{9}{7} \times \frac{81}{67} + \frac{6561}{5623} \\ &= 3 \times \frac{3}{2} \times \frac{9}{7} \times \frac{81}{67} \times \frac{6561}{5623} \end{aligned}$$

Project

Write down two 1's, then a 2 between them, then a 3 between any two numbers whose sum is 3, then a 4 between any two numbers whose sum is 4, and so forth. How many n 's are there in the sequence?

Chapter 6

Pythagorean triples

- 1 Primitive Pythagorean triples
 - 2 Primitive Pythagorean triples with square perimeter
 - 3 Lewis Carroll's conjecture on infinity of triples of equiareal Pythagorean triangles
 - 4 Points at integer distances from the sides of a Pythagorean triangle
 - 5 Dissecting a rectangle into Pythagorean triangles
- Appendix: Primitive Pythagorean triples < 1000
- Appendix: Dissection of a square
- Exercise
- Project: Factorable $x^2 + px \pm q$
- Project: 64 primitive Pythagorean triangles with a common hypotenuse
- Project: Primitive Pythagorean triangles with equal perimeters
- Project: Two pairs of primitive Pythagorean triples with almost equal perimeters
- Project: Cross number puzzle on Pythagorean triples

6.1 Primitive Pythagorean triples

It is well known that every primitive Pythagorean triple (a, b, c) is of the form

$$a = m^2 - n^2, \quad b = 2mn, \quad c = m^2 + n^2$$

for relatively prime integers m and n of different parity.

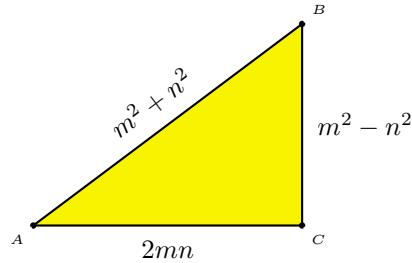

Some basic properties of Pythagorean triples:

1. Exactly one leg is even.
2. Exactly one leg is divisible by 3.
3. Exactly one side is divisible by 5.
4. The area is divisible by 6. Fermat has proved that the area of a Pythagorean triangle can never be a square. Indeed, there is no Pythagorean triangle with two sides whose lengths are square (numbers).

6.2 Primitive Pythagorean triangles with square perimeters

If $m > n$ are relatively prime integers of opposite parity, they generate a primitive Pythagorean triple $(a, b, c) = (m^2 - n^2, 2mn, m^2 + n^2)$ with perimeter $p = 2m(m + n)$. If this perimeter is a square (number), we must have $m = 2q^2$ and $m + n = p^2$ for some integers p and q . From these, $(m, n) = (2q^2, p^2 - 2q^2)$.

$$\begin{aligned} a &= m^2 - n^2 = p^2(4q^2 - p^2), \\ b &= 2mn = 4q^2(p^2 - 2q^2), \\ c &= m^2 + n^2 = p^4 - 4p^2q^2 + 8q^4. \end{aligned}$$

Note that p is odd, $\lceil \sqrt{2}q \rceil \leq p < 2q$, and $\gcd(p, q) = 1$. The perimeter is $4p^2q^2 = (2pq)^2$.

Here are the first few of such triangles. The last column gives the square root of the perimeter.

p	q	m	n	a	b	c	$2pq$
3	2	8	1	63	16	65	12
5	3	18	7	275	252	373	30
7	4	32	17	735	1088	1313	56
9	5	50	31	1539	3100	3461	90
11	6	72	49	2783	7056	7585	132
11	7	98	23	9075	4508	10133	154
13	7	98	71	4563	13916	14645	182
13	8	128	41	14703	10496	18065	208
15	8	128	97	6975	24832	25793	240
13	9	162	7	26195	2268	26293	234
17	9	162	127	10115	41148	42373	306
17	10	200	89	32079	35600	47921	340
19	10	200	161	14079	64400	65921	380
\vdots	\vdots						

6.3 Lewis Carroll's conjecture on triples of equiareal Pythagorean triangles

Lewis Carroll conjectured that there is an infinity of Pythagorean triangles with equal areas. If (p, q, r) satisfy $p^2 + pq + q^2 = r^2$, then the Pythagorean triangles generated by (r, p) , (r, q) , and $(p + q, r)$ have the same area $pqr(p + q)$. Since there is an infinity of such triangles, there conjecture is established. This is essentially in Diophantus.

6.4 Points at integer distances from the sides of a primitive Pythagorean triangle

Let (a, b, c) be a primitive Pythagorean triangle, with vertices $(a, 0)$, $(0, b)$, and $(0, 0)$. The hypotenuse is the line $bx + ay = ab$. The distance of an interior point (x, y) to the hypotenuse is $\frac{1}{c}(ab - bx - ay)$. We seek interior points which are at integer distances from the hypotenuse.

With the parameters $(6, 1)$ we have the Pythagorean triangle $(35, 12, 37)$. Here the five points $(29, 1)$, $(23, 2)$, $(17, 3)$, $(11, 4)$, $(5, 5)$ are at distances 1, 2, 3, 4, 5 from the hypotenuse.

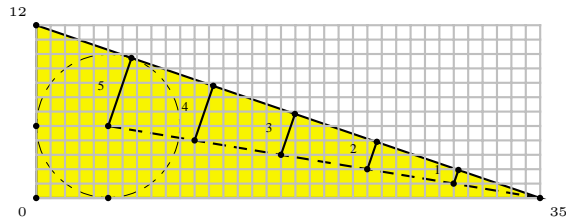

Another example: with parameters $(5, 2)$ we have the triangle $(21, 20, 29)$. Here we have the interior points $(8, 11)$, $(16, 2)$, $(3, 13)$, $(11, 4)$, $(6, 6)$, $(1, 8)$, $(4, 1)$ at distances 1, 2, 3, 4, 6, 8, 11 from the hypotenuse. The arrangement is not as regular as the previous example.

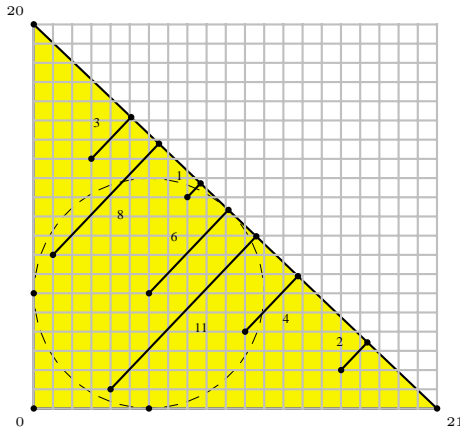

6.5 Dissecting a rectangle into Pythagorean triangles

How many matches (of equal lengths) are required to make up the following figure?

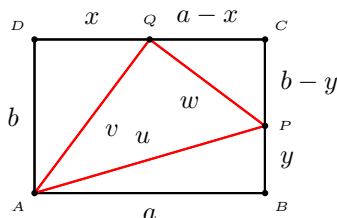

This is Problem 2237 of the *Journal of Recreational Mathematics*, which asks for the

- (i) the smallest such rectangle,
- (ii) the smallest such rectangle with $AP = AQ$,
- (iii) the smallest such rectangle with APQ Pythagorean,
- (iv) the smallest square.

In (iii), the three right triangles QPC , AQD and APQ are similar. If they are similar to the Pythagorean triangle $a : b : c$, the ratios of similarity are also $a : b : c$. If we put $CP = a^2$, then the lengths of the various segments are as shown below. Note that ABP now is a Pythagorean triangle with parameters b and a . With $(a, b, c) = (3, 4, 5)$, we obtain the smallest rectangle satisfying (iv). This also answers (i) since it is clearly also the smallest rectangle (with any restrictions).

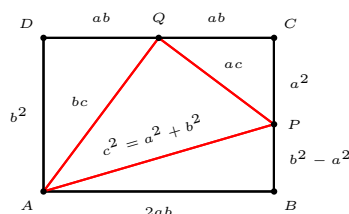

(ii) is also tractable without the help of a computer. Here, we want two Pythagorean triangles with the same hypotenuse. It is well known that the smallest such hypotenuse is 65. Indeed, $65^2 = 63^2 + 16^2 = 56^2 + 33^2$. From this it is easy to complete the data.

The answer to (iv) is given in the Appendix.

Appendix: Primitive Pythagorean triples < 1000

m, n	a, b, c	m, n	a, b, c	m, n	a, b, c	m, n	a, b, c
2, 1	3, 4, 5	3, 2	5, 12, 13	4, 1	15, 8, 17	4, 3	7, 24, 25
5, 2	21, 20, 29	5, 4	9, 40, 41	6, 1	35, 12, 37	6, 5	11, 60, 61
7, 2	45, 28, 53	7, 4	33, 56, 65	7, 6	13, 84, 85	8, 1	63, 16, 65
8, 3	55, 48, 73	8, 5	39, 80, 89	8, 7	15, 112, 113	9, 2	77, 36, 85
9, 4	65, 72, 97	9, 8	17, 144, 145	10, 1	99, 20, 101	10, 3	91, 60, 109
10, 7	51, 140, 149	10, 9	19, 180, 181	11, 2	117, 44, 125	11, 4	105, 88, 137
11, 6	85, 132, 157	11, 8	57, 176, 185	11, 10	21, 220, 221	12, 1	143, 24, 145
12, 5	119, 120, 169	12, 7	95, 168, 193	12, 11	23, 264, 265	13, 2	165, 52, 173
13, 4	153, 104, 185	13, 6	133, 156, 205	13, 8	105, 208, 233	13, 10	69, 260, 269
13, 12	25, 312, 313	14, 1	195, 28, 197	14, 3	187, 84, 205	14, 5	171, 140, 221
14, 9	115, 252, 277	14, 11	75, 308, 317	14, 13	27, 364, 365	15, 2	221, 60, 229
15, 4	209, 120, 241	15, 8	161, 240, 289	15, 14	29, 420, 421	16, 1	255, 32, 257
16, 3	247, 96, 265	16, 5	231, 160, 281	16, 7	207, 224, 305	16, 9	175, 288, 337
16, 11	135, 352, 377	16, 13	87, 416, 425	16, 15	31, 480, 481	17, 2	285, 68, 293
17, 4	273, 136, 305	17, 6	253, 204, 325	17, 8	225, 272, 353	17, 10	189, 340, 389
17, 12	145, 408, 433	17, 14	93, 476, 485	17, 16	33, 544, 545	18, 1	323, 36, 325
18, 5	299, 180, 349	18, 7	275, 252, 373	18, 11	203, 396, 445	18, 13	155, 468, 493
18, 17	35, 612, 613	19, 2	357, 76, 365	19, 4	345, 152, 377	19, 6	325, 228, 397
19, 8	297, 304, 425	19, 10	261, 380, 461	19, 12	217, 456, 505	19, 14	165, 532, 557
19, 16	105, 608, 617	19, 18	37, 684, 685	20, 1	399, 40, 401	20, 3	391, 120, 409
20, 7	351, 280, 449	20, 9	319, 360, 481	20, 11	279, 440, 521	20, 13	231, 520, 569
20, 17	111, 680, 689	20, 19	39, 760, 761	21, 2	437, 84, 445	21, 4	425, 168, 457
21, 8	377, 336, 505	21, 10	341, 420, 541	21, 16	185, 672, 697	21, 20	41, 840, 841
22, 1	483, 44, 485	22, 3	475, 132, 493	22, 5	459, 220, 509	22, 7	435, 308, 533
22, 9	403, 396, 565	22, 13	315, 572, 653	22, 15	259, 660, 709	22, 17	195, 748, 773
22, 19	123, 836, 845	22, 21	43, 924, 925	23, 2	525, 92, 533	23, 4	513, 184, 545
23, 6	493, 276, 565	23, 8	465, 368, 593	23, 10	429, 460, 629	23, 12	385, 552, 673
23, 14	333, 644, 725	23, 16	273, 736, 785	23, 18	205, 828, 853	23, 20	129, 920, 929
24, 1	575, 48, 577	24, 5	551, 240, 601	24, 7	527, 336, 625	24, 11	455, 528, 697
24, 13	407, 624, 745	24, 17	287, 816, 865	24, 19	215, 912, 937	25, 2	621, 100, 629
25, 4	609, 200, 641	25, 6	589, 300, 661	25, 8	561, 400, 689	25, 12	481, 600, 769
25, 14	429, 700, 821	25, 16	369, 800, 881	25, 18	301, 900, 949	26, 1	675, 52, 677
26, 3	667, 156, 685	26, 5	651, 260, 701	26, 7	627, 364, 725	26, 9	595, 468, 757
26, 11	555, 572, 797	26, 15	451, 780, 901	26, 17	387, 884, 965	27, 2	725, 108, 733
27, 4	713, 216, 745	27, 8	665, 432, 793	27, 10	629, 540, 829	27, 14	533, 756, 925
27, 16	473, 864, 985	28, 1	783, 56, 785	28, 3	775, 168, 793	28, 5	759, 280, 809
28, 9	703, 504, 865	28, 11	663, 616, 905	28, 13	615, 728, 953	29, 2	837, 116, 845
29, 4	825, 232, 857	29, 6	805, 348, 877	29, 8	777, 464, 905	29, 10	741, 580, 941
29, 12	697, 696, 985	30, 1	899, 60, 901	30, 7	851, 420, 949	31, 2	957, 124, 965
31, 4	945, 248, 977	31, 6	925, 372, 997				

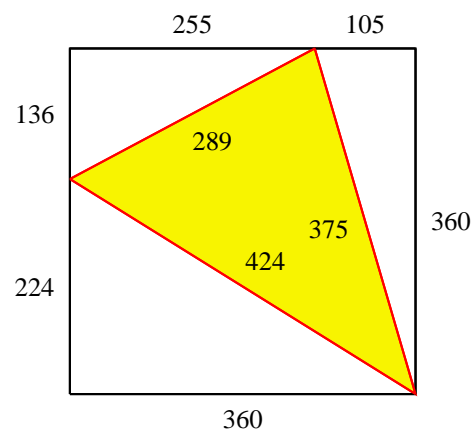
Appendix: Dissection of a square

Exercise

1. A man has a square field, 60 feet by 60 feet, with other property adjoining the highway. He put up a straight fence in the line of 3 trees, at A , P , Q . If the distance between P and Q is 91 feet, and that from P to B is an exact number of feet, what is this distance?

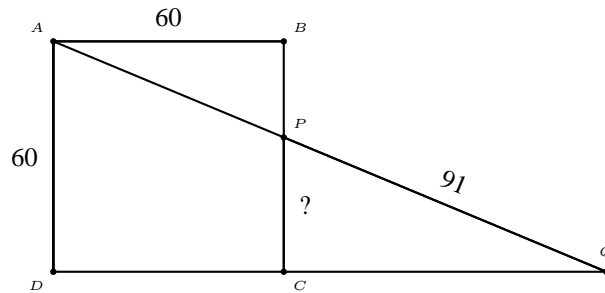

2. What is the least number of matches of equal lengths to make up the following configuration?

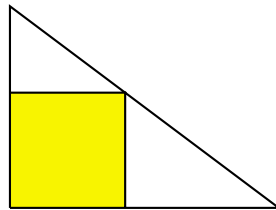

3. What is the least number of matches of equal lengths to make up the following configuration?

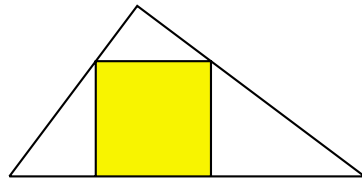

4. Do there exist Pythagorean triangles whose sides are Fibonacci numbers?
5. Give an example of a primitive Pythagorean triangle in which the hypotenuse is a square.
6. Give an example of a primitive Pythagorean triangle in which the *even* leg is a square.

7. Give an example of a primitive Pythagorean triangle in which the *odd* leg is a square. triangle to be a square?
8. Find the shortest perimeter common to two different primitive Pythagorean triangles.
9. Find an integer-sided right angled triangle with sides $x^2 - 1$, $y^2 - 1$, $z^2 - 1$, where x, y, z are integers.
10. The number of *primitive* Pythagorean triangle with a fixed inradius is always a power of 2.
11. Show that there are an infinite number of Pythagorean triangles whose hypotenuse is an integer of the form $3333 \cdots 3$.
12. For each natural number n , how many Pythagorean triangles are there such that the area is n times the perimeter ? How many of these are primitive ?

Project: Factorable $x^2 + px \pm q$

Theorem 6.1. *Let p and q be relatively prime integers. The polynomials $x^2 + px \pm q$ are both factorable (over integers) if and only if $|p|$ and $|q|$ are respectively the hypotenuse and area of a primitive Pythagorean triangle.*

Project: 64 primitive Pythagorean triangles with a common hypotenuse

A product of $n + 1$ distinct prime numbers of the form $4k + 1$ can be written a sum of two squares in 2^n different ways, repeatedly by making use of the identity

$$(x_1^2 + y_1^2)(x_2^2 + y_2^2) = (x_1x_2 - y_1y_2)^2 + (x_1y_2 + x_2y_1)^2.$$

The first 7 primes of the form $4k + 1$ are 5, 13, 17, 29, 37, 41, and 53. Their product is 2576450045. What are the 64 triples?

Project: Primitive Pythagorean triangles with equal perimeters

perimeter	$m + n$	$2m$	m	n	a	b	c
1716	33						
	39						
14280	85						
	105						
	119						
317460	407						
	429						
	481						
	555						
1542684	899						
	957						
	1023						
	1131						
	1209						
6240360	1785						
	1955						
	1995						
	2185						
	2261						
	2415						
19399380	3135						
	3315						
	3553						
	3705						
	3927						
	4199						
	4389						

Project: Two pairs of primitive Pythagorean triples with almost equal perimeters

In a class in Number Theory the professor gave four students the assignment of finding a fairly large primitive Pythagorean triangle using the well known formula for the legs:

$$A = 2mn, \quad B = m^2 - n^2, \quad C = m^2 + n^2,$$

where m and n are coprime integers, not both odd. The four students produced four entirely different primitive triangles, but on comparing them it was found that two of them had the same perimeter, while the other two also had the same perimeter, this perimeter differing from the first one by 2. This interested the class greatly, and much time was spent in an effort to find other such sets, only to discover that there were only four such sets with perimeters less than 500,000. Can you find at least one such set ?

perimeter	$m + n$	$2m$	m	n	a	b	c
117390	273						
	301						
117392	253						
	319						
313038	459						
	527						
313040	455						
	559						
339150	425						
	475						
	525						
339152	451						
	517						
371448	469						
	603						
371450	437						
	475						
	575						

Project: Cross number puzzle on primitive Pythagorean triples¹

1	2	3		4	5		6
7			8			9	
	10	11		12	13		
14	15	16		17	18		19
20			21			22	
	23	24		25	26		
27	28	29		30	31		32
33			34			35	

1B, 3D, 9B	29B, 7A, 21D	12B, 11U, 20U
2D, 6D, 5B	19U, 15D, 7D	22D, 18B, 15U
27A, 2D, 26D	20A, 8D, 8A	16A, 31A, 33A
5D, 3A, 25B	30D, 14A, 9A	16B, 24D, 23B
28D, 35A, 3U	30U, 9U, 13D	22A, 32U, 32D
4U, 21A, 21D	19U, 17D, 10A	32U, 34A, 33A

The answers are distinct 2- and 3-digit decimal numbers, none beginning with zero. Each of the above sets of answers is a primitive Pythagorean triple, in increasing size, so that the third member is the hypotenuse.

A = across, B = back, D = down, U = up.

For example, 1B has its tens and units digits in the squares labelled 2 and 1 respectively; 11U is a 3-digit number with its tens and units digits in squares 16 and 11 respectively.

¹R. K. Guy, Problem 1153, *Crux Math.*, 12 (1986) 139.

Chapter 7

The tangrams

- 1 The Chinese tangram
 - 2 A British tangram
 - 3 Another British tangram
- Project

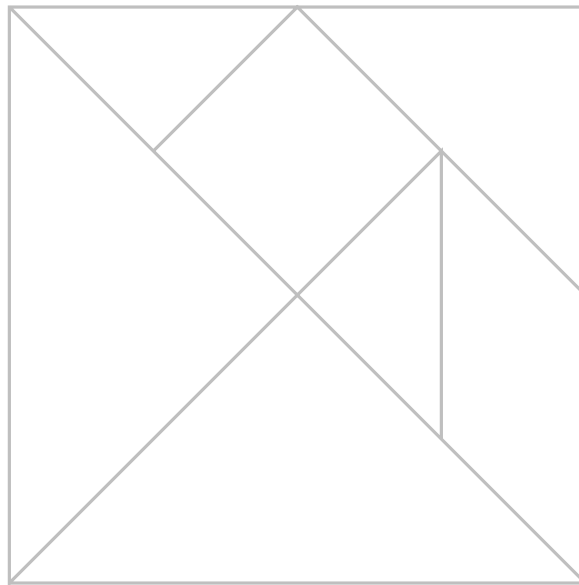

7.1 The Chinese tangram

It is known that exactly 13 **convex** polygons can be formed from the tangram. ¹ Show them. ²

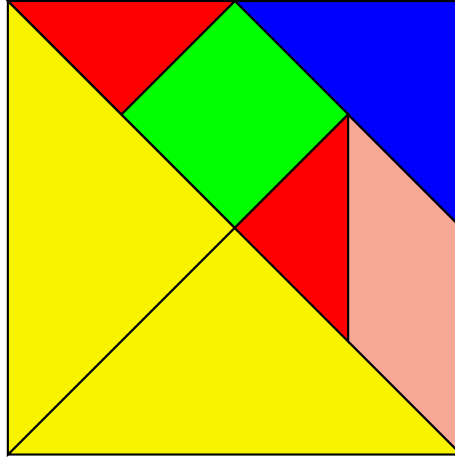

A very interesting book on the Chinese tangram has recently appeared: J. Slocum, *The Tangram Book*, Sterling, New York, 2003. I finally know what the mysterious Chinese character on p.45 of Dudeney's *Amusements in Mathematics* is. The undeciphered Chinese character is *zhuó*, to drink. The Chinese inscription reads

Liǎng rén duì zhuó (Two people having a drink together),
cǐ qī qiǎo zhī huǎjǐng yě! (what a sublimity of the tangram!)

¹F. T. Wang and C. C. Hsiung, A theorem on the tangram, *American Math. Monthly*, 49 (1942) 596–599.

²There are 1 triangle, 6 quadrilaterals, 2 pentagons, and 4 hexagons.

7.2 A British tangram

The seven pieces of the puzzle can be fitted together as shown in the figure to make a perfect square. All sloping lines are at 45° , and the lines which intersect the outer square do so at the midpoints of the sides. Find all ways of making a rectangle using all of these pieces.³

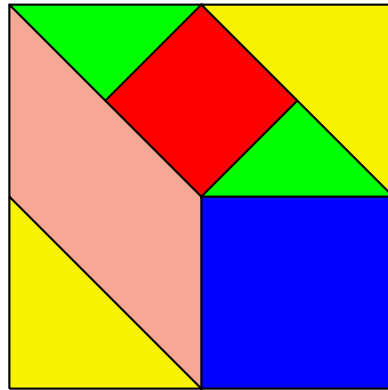

³Singmaster, Problem 267, *Journal of Recreational Math.*, 6 (1973) 152–153.

7.3 Another British tangram

Ten pieces of the puzzle can be fitted together as shown in the figure to make 4×5 rectangle. All sloping lines are at 45° .⁴

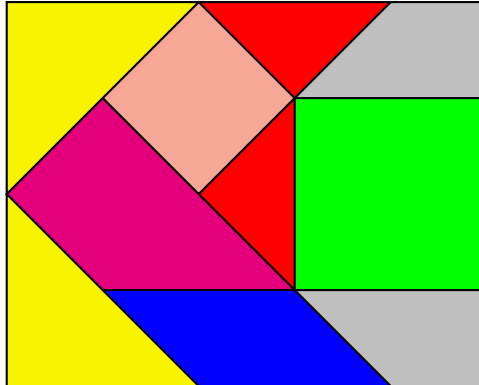

- (1) Are there any solution with the green square in a corner or not touching a side?
- (2) Prove or disprove: any solution has the two gray trapezoids and the green square in the above relative positions.
- (3) Find all solutions.

⁴Singmaster, Problem 812, *Journal of Recreational Math.*, 13 (1980–1981) 62–63.

Project

Show how to dissect a 3-4-5 triangle into 4 pieces that may be rearranged into a square.⁵

⁵S. Rabinowitz, Problem 1299, *Journal Recreational Math.*, 16 (1983–1984) 139.

Chapter 8

The classical triangle centers

- 1 The centroid
 - 2 The circumcenter and the circumcircle
 - 3 The incenter and the incircle
 - 4 The orthocenter and the Euler line
 - 5 The excenters and the excircles
- Exercise

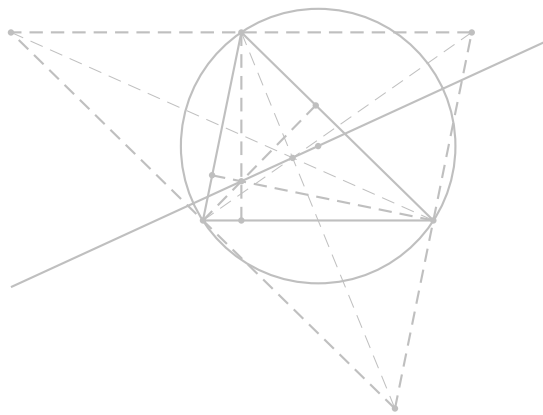

The following triangle centers have been known since ancient times. We shall adopt the following notations. Let ABC be a given triangle. The lengths of the sides BC , CA , AB opposite to A , B , C are denoted by a , b , c .

8.1 The centroid

The centroid G is the intersection of the three medians. It divides each median in the ratio $2 : 1$.

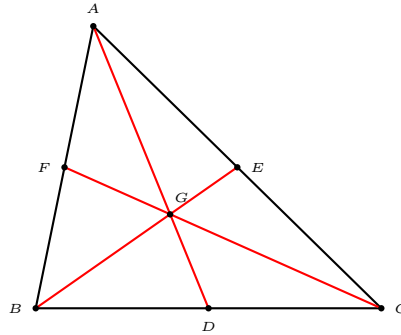

The triangle DEF is called the *medial* triangle of ABC . It is the image of ABC under the homothety $h(G, -\frac{1}{2})$.

The lengths of the medians are given by Apollonius' theorem:

$$m_a^2 = \frac{1}{4}(2b^2 + 2c^2 - a^2),$$

etc.

Exercise

Calculate the lengths of the medians of a triangle whose sidelengths are 136, 170, and 174.

8.2 The circumcircle and the circumcenter

The perpendicular bisectors of the three sides of a triangle are concurrent at the *circumcenter* of the triangle. This is the center of the circumcircle, the circle passing through the three vertices of the triangle.

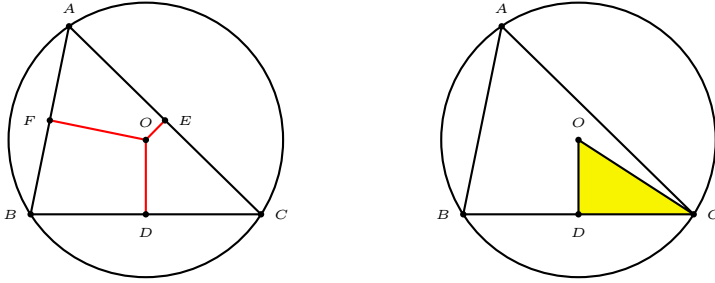

Theorem 8.1 (The law of sines). Let R denote the circumradius of a triangle ABC with sides a, b, c opposite to the angles A, B, C respectively.

$$\frac{a}{\sin A} = \frac{b}{\sin B} = \frac{c}{\sin C} = 2R.$$

Since the area of a triangle is given by $\Delta = \frac{1}{2}bc \sin A$, the circumradius can be written as

$$R = \frac{abc}{4\Delta}.$$

8.3 The incenter and the incircle

The internal angle bisectors of a triangle are concurrent at the *incenter* of the triangle. This is the center of the *incircle*, the circle tangent to the three sides of the triangle.

If the incircle touches the sides BC , CA and AB respectively at X , Y , and Z ,

$$AY = AZ = s - a, \quad BX = BZ = s - b, \quad CX = CY = s - c.$$

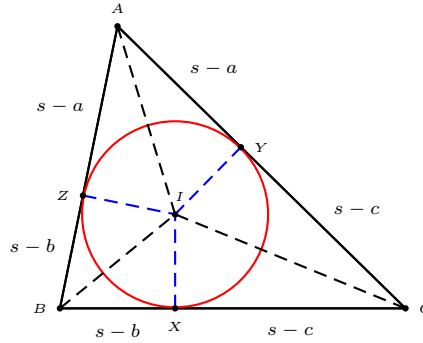

Denote by r the inradius of the triangle ABC .

$$r = \frac{2\Delta}{a + b + c} = \frac{\Delta}{s}.$$

8.4 The orthocenter and the Euler line

The orthocenter H is the intersection of the three altitudes of triangle ABC . These altitudes can be seen as the perpendicular bisectors of the *antimedial* triangle XYZ of ABC , which is bounded by the three lines each passing through A, B, C parallel to their respective opposite sides.

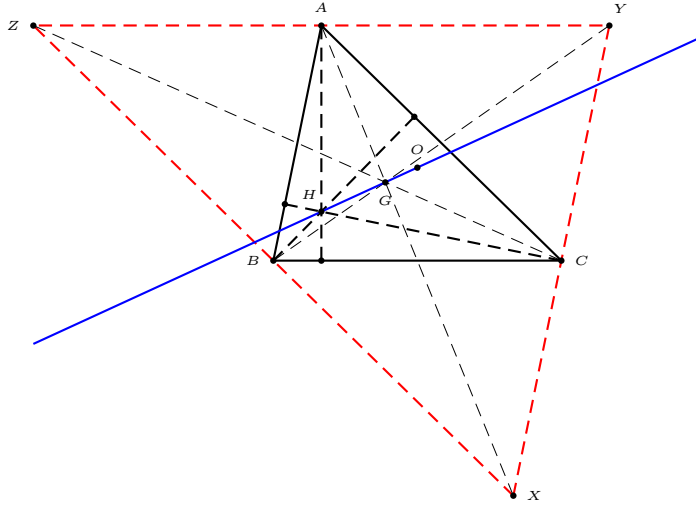

XYZ is the image of triangle ABC under the homothety $h(G, -2)$. It follows that H is the image of O under the same homothety. We conclude that O, G , and H are collinear, and $OG : GH = 1 : 2$.

The line containing O, G, H is the famous Euler line of triangle ABC .

8.5 The excenters and the excircles

The internal bisector of each angle and the *external* bisectors of the remaining two angles are concurrent at an *excenter* of the triangle. An *excircle* can be constructed with this as center, tangent to the lines containing the three sides of the triangle.

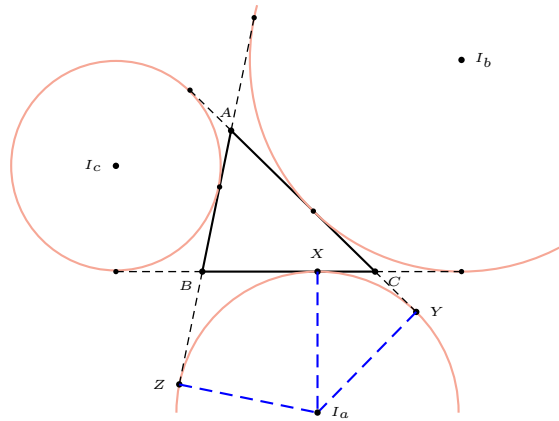

The exradii of a triangle with sides a, b, c are given by

$$r_a = \frac{\Delta}{s - a}, \quad r_b = \frac{\Delta}{s - b}, \quad r_c = \frac{\Delta}{s - c}.$$

Exercise

1. Given a triangle ABC , construct a triangle whose sides have the same lengths as the medians of ABC .
2. Construct the incircle of triangle ABC , and mark the points of contact X on BC , Y on CA , and Z on AB . Are the lines AX , BY , CZ concurrent? If so, is their intersection the incenter of triangle ABC ?
3. Given a rectangle $ABCD$, construct points P on BC and Q on CD such that the triangle APQ is equilateral.
4. Let D , E , F be the midpoints of BC , CA , AB of triangle ABC . Construct the circumcircle of DEF . This is called the *nine-point circle* of triangle ABC . Construct also the incircle of triangle ABC . What do you observe about the two circles? How would you justify your observation?
5. Construct the circle through the excenters of triangle ABC . How is its center related to the circumcenter and incenter of triangle ABC ?
6. Given three non-collinear points as centers, construct three circles mutually tangent to each other externally.

Chapter 9

The area of a triangle

- 1 Heron's formula for the area of a triangle
 - 2 Heron triangles
 - 3 Heron triangles with consecutive sides
- Appendix: Heron triangles with sides < 1000
Appendix: A famous unsolved problem
Project: Triangles whose sides and one altitude are in arithmetic progression

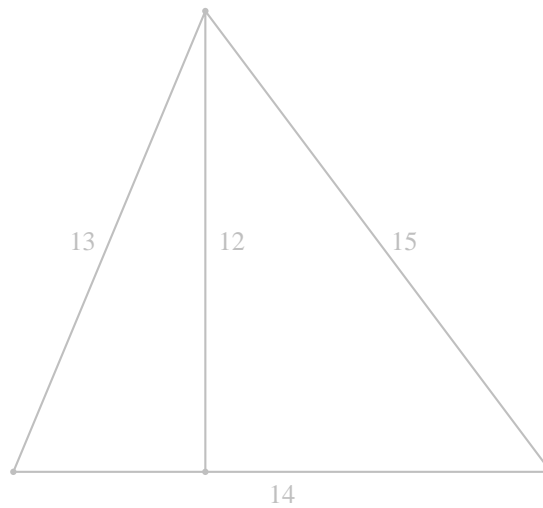

9.1 Heron's formula for the area of a triangle

Theorem 9.1. *The area of a triangle of sidelengths a, b, c is given by*

$$\Delta = \sqrt{s(s-a)(s-b)(s-c)},$$

where $s = \frac{1}{2}(a+b+c)$.

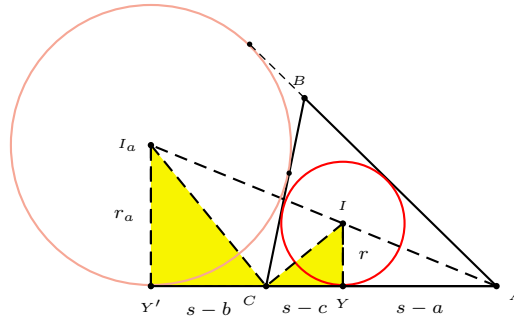

Proof. Consider the incircle and the excircle on the opposite side of A . From the similarity of triangles AIY and $AI'Y'$,

$$\frac{r}{r_a} = \frac{s-a}{s}.$$

From the similarity of triangles CIY and $I'CY'$,

$$r \cdot r_a = (s-b)(s-c).$$

From these,

$$r = \sqrt{\frac{(s-a)(s-b)(s-c)}{s}},$$

and the area of the triangle is

$$\Delta = rs = \sqrt{s(s-a)(s-b)(s-c)}.$$

□

9.2 Heron triangles

A Heron triangle is one whose sidelengths and area are both integers. It can be constructed by joining two integer right triangles along a common leg. For example, by joining the two Pythagorean triangles $(9, 12, 15)$ and $(5, 12, 13)$, we obtain the Heron triangle $(13, 14, 15)$ with area 84.

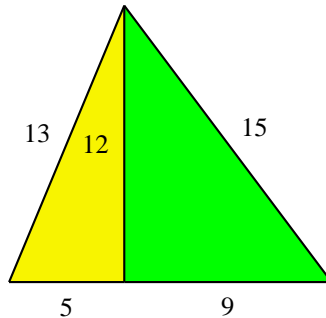

Some properties of Heron triangles

1. The semiperimeter is an integer.
2. The area is always a multiple of 6.

Exercise

1. Construct four Heron triangles by joining suitable multiples of $(3,4,5)$ and $(5,12,13)$ along common legs. The Heron triangles you obtain should be primitive, *i.e.*, the sidelengths of each should be relatively prime.
2. Can the Heron triangle $(25,34,39,420)$ be obtained by joining two Pythagorean triangles along a common leg?

9.3 Heron triangles with consecutive sides

If $(b-1, b, b+1, \Delta)$ is a Heron triangle, then b must be an even integer. We write $b = 2m$. Then $s = 3m$, and $\Delta^2 = 3m^2(m-1)(m+1)$. This requires $m^2 - 1 = 3k^2$ for an integer k , and $\Delta = 3km$. The solutions of $m^2 - 3k^2 = 1$ can be arranged in a sequence

$$\begin{pmatrix} m_{n+1} \\ k_{n+1} \end{pmatrix} = \begin{pmatrix} 2 & 3 \\ 1 & 2 \end{pmatrix} \begin{pmatrix} m_n \\ k_n \end{pmatrix}, \quad \begin{pmatrix} m_1 \\ k_1 \end{pmatrix} = \begin{pmatrix} 2 \\ 1 \end{pmatrix}.$$

From these, we obtain the side lengths and the area.

The middle sides form a sequence (b_n) given by

$$b_{n+2} = 4b_{n+1} - b_n, \quad b_0 = 2, \quad b_1 = 4.$$

The areas of the triangles form a sequence

$$\Delta_{n+2} = 14\Delta_{n+1} - \Delta_n, \quad T_0 = 0, \quad T_1 = 6.$$

n	b_n	T_n	Heron triangle
0	2	0	(1, 2, 3, 0)
1	4	6	(3, 4, 5, 6)
2	14	84	(13, 14, 15, 84)
3			
4			
5			

Exercise

1. There is a uniquely Heron triangle with sides $(b-1, b, b+1)$ in which b is an 8-digit number. What is the area of this Heron triangle?

Appendix: Heron triangles with sides < 100

(a, b, c, Δ)	(a, b, c, Δ)	(a, b, c, Δ)	(a, b, c, Δ)	(a, b, c, Δ)
(3, 4, 5, 6)	(5, 5, 6, 12)	(5, 5, 8, 12)	(5, 12, 13, 30)	(10, 13, 13, 60)
(4, 13, 15, 24)	(13, 14, 15, 84)	(9, 10, 17, 36)	(8, 15, 17, 60)	(16, 17, 17, 120)
(11, 13, 20, 66)	(7, 15, 20, 42)	(10, 17, 21, 84)	(13, 20, 21, 126)	(13, 13, 24, 60)
(12, 17, 25, 90)	(7, 24, 25, 84)	(14, 25, 25, 168)	(3, 25, 26, 36)	(17, 25, 26, 204)
(17, 25, 28, 210)	(20, 21, 29, 210)	(6, 25, 29, 60)	(17, 17, 30, 120)	(11, 25, 30, 132)
(5, 29, 30, 72)	(8, 29, 35, 84)	(15, 34, 35, 252)	(25, 29, 36, 360)	(19, 20, 37, 114)
(15, 26, 37, 156)	(13, 30, 37, 180)	(12, 35, 37, 210)	(24, 37, 37, 420)	(16, 25, 39, 120)
(17, 28, 39, 210)	(25, 34, 39, 420)	(10, 35, 39, 168)	(29, 29, 40, 420)	(13, 37, 40, 240)
(25, 39, 40, 468)	(15, 28, 41, 126)	(9, 40, 41, 180)	(17, 40, 41, 336)	(18, 41, 41, 360)
(29, 29, 42, 420)	(15, 37, 44, 264)	(17, 39, 44, 330)	(13, 40, 45, 252)	(25, 25, 48, 168)
(29, 35, 48, 504)	(21, 41, 50, 420)	(39, 41, 50, 780)	(26, 35, 51, 420)	(20, 37, 51, 306)
(25, 38, 51, 456)	(13, 40, 51, 156)	(27, 29, 52, 270)	(25, 33, 52, 330)	(37, 39, 52, 720)
(15, 41, 52, 234)	(5, 51, 52, 126)	(25, 51, 52, 624)	(24, 35, 53, 336)	(28, 45, 53, 630)
(4, 51, 53, 90)	(51, 52, 53, 1170)	(26, 51, 55, 660)	(20, 53, 55, 528)	(25, 39, 56, 420)
(53, 53, 56, 1260)	(33, 41, 58, 660)	(41, 51, 58, 1020)	(17, 55, 60, 462)	(15, 52, 61, 336)
(11, 60, 61, 330)	(22, 61, 61, 660)	(25, 52, 63, 630)	(33, 34, 65, 264)	(20, 51, 65, 408)
(12, 55, 65, 198)	(33, 56, 65, 924)	(14, 61, 65, 420)	(36, 61, 65, 1080)	(16, 63, 65, 504)
(32, 65, 65, 1008)	(35, 53, 66, 924)	(65, 65, 66, 1848)	(21, 61, 68, 630)	(43, 61, 68, 1290)
(7, 65, 68, 210)	(29, 65, 68, 936)	(57, 65, 68, 1710)	(29, 52, 69, 690)	(37, 37, 70, 420)
(9, 65, 70, 252)	(41, 50, 73, 984)	(26, 51, 73, 420)	(35, 52, 73, 840)	(48, 55, 73, 1320)
(19, 60, 73, 456)	(50, 69, 73, 1656)	(25, 51, 74, 300)	(25, 63, 74, 756)	(35, 44, 75, 462)
(29, 52, 75, 546)	(32, 53, 75, 720)	(34, 61, 75, 1020)	(56, 61, 75, 1680)	(13, 68, 75, 390)
(52, 73, 75, 1800)	(40, 51, 77, 924)	(25, 74, 77, 924)	(68, 75, 77, 2310)	(41, 41, 80, 360)
(17, 65, 80, 288)	(9, 73, 80, 216)	(39, 55, 82, 924)	(35, 65, 82, 1092)	(33, 58, 85, 660)
(29, 60, 85, 522)	(39, 62, 85, 1116)	(41, 66, 85, 1320)	(36, 77, 85, 1386)	(13, 84, 85, 546)
(41, 84, 85, 1680)	(26, 85, 85, 1092)	(72, 85, 85, 2772)	(34, 55, 87, 396)	(52, 61, 87, 1560)
(38, 65, 87, 1140)	(44, 65, 87, 1386)	(31, 68, 87, 930)	(61, 74, 87, 2220)	(65, 76, 87, 2394)
(53, 75, 88, 1980)	(65, 87, 88, 2640)	(41, 50, 89, 420)	(28, 65, 89, 546)	(39, 80, 89, 1560)
(21, 82, 89, 840)	(57, 82, 89, 2280)	(78, 89, 89, 3120)	(53, 53, 90, 1260)	(17, 89, 90, 756)
(37, 72, 91, 1260)	(60, 73, 91, 2184)	(26, 75, 91, 840)	(22, 85, 91, 924)	(48, 85, 91, 2016)
(29, 75, 92, 966)	(39, 85, 92, 1656)	(34, 65, 93, 744)	(39, 58, 95, 456)	(41, 60, 95, 798)
(68, 87, 95, 2850)	(73, 73, 96, 2640)	(37, 91, 96, 1680)	(51, 52, 97, 840)	(65, 72, 97, 2340)
(26, 73, 97, 420)	(44, 75, 97, 1584)	(35, 78, 97, 1260)	(75, 86, 97, 3096)	(11, 90, 97, 396)
(78, 95, 97, 3420)				

Appendix: A famous unsolved problem

Find a Heron triangle whose medians have integer lengths. This is a famous unsolved problem. See [Guy, Problem D21]. The triangle with sides 136, 170, 174 have medians 158, 131, 127. But it is not a Heron triangle. It has an area _____.

Buchholz and Rathbun have found an infinite set of Heron triangles with two integer medians. Here is the first one.

Let $a = 52$, $b = 102$, and $c = 146$.

Verify that this triangle is Heron and find the lengths of the medians.

Project: Triangles whose sides and one altitude are in arithmetic progression

This is an extension of Problem 29 of Isaac Newton's *Lectures on Algebra* ([Whiteside, pp.234 – 237]).

(A) Newton considered a triangle ABC with an altitude DC . Clearly, DC is shorter than AC and BC . Setting $AC = a$, $BC = x$, $DC = 2x - a$, and $AB = 2a - x$, he obtained

$$16x^4 - 80ax^3 + 144a^2x^2 - 10a^3x + 25a^4 = 0. \quad (\dagger)$$

“Divide this equation by $2x - a$ and there will result $8x^3 - 36ax^2 + 54a^2x - 25a^3 = 0$ ”. Newton did not solve this equation nor did he give any numerical example. Actually, (\dagger) can be rewritten as

$$(2x - 3a)^3 + 2a^3 = 0,$$

so that $x = \frac{a}{2}(3 - \sqrt[3]{2})$, the other two roots being complex. By taking $a = 2$, we may assume the sides of the triangles to be

_____, _____, _____,

and the altitude on the longest side to be _____.

The angles of the triangles are

_____, _____, _____.

(B) Recalling the Heron triangle with sides 13, 14, 15 with altitude 12 on the side 14, we realize that these lengths can be in A.P. in some other order. Note that the altitude in question is either the first or the second terms of the A.P. (in increasing order). Assuming unit length for this altitude, and $x > 0$ for the common difference, we have either

1. the three sides of the triangles are $1 + x$, $1 + 2x$, and $1 + 3x$, or
2. the sides of the triangles are $1 - x$, $1 + x$, and $1 + 2x$, and the altitude on the shortest side is 1.

In (1), the area of the triangle, by the Heron formula, is given by

$$\Delta^2 = \frac{3}{16}(1 + 2x)^2(1 + 4x).$$

On the other hand, $\Delta = \frac{1}{2} \cdot 1 \cdot (1 + kx)$ for $k = 1, 2, 3$. These lead to the equations

- for $k = 1$: $48x^3 + 56x^2 + 16x - 1 = 0$,
- for $k = 2$: $48x^3 + 44x^2 + 8x - 1 = 0$,
- for $k = 3$: $48x^3 + 24x - 1 = 0$.

The case $k = 3$ has been dealt with in Newton's solution.

For $k = 2$, the polynomial factors as _____
so that we have $x =$ _____. This leads to the Heronian triangle
with sides 13, 14, 15, and altitude 12 on the side 14. The angles of the
triangles are

_____, _____, _____.

For $k = 1$, it is easy to see, using elementary calculus, that the poly-
nomial $48x^3 + 56x^2 + 16x - 1$ has exactly one real root, which is positive.

This gives a similarity class of triangle with the three sides and the
altitude on the shortest side in A.P. More detailed calculation shows that
the angles of such triangles are

_____, _____, _____.

Now we consider (2), when the altitude in question is the second term
of the A.P. Instead of constructing an equation in x , we seek one such
triangle with sides 15, $17 + 2z$, $18 + 3z$, and the altitude $16 + z$ on the
shortest side. By considering the area of the triangle in two different
ways, we obtain the cubic equation

$$z^3 - 120z + 16 = 0. \quad (*)$$

This can be solved by writing $z = 4\sqrt{10}\sin\theta$ for an angle θ . Using the
trigonometric identity $\sin 3\theta = 3\sin\theta - 4\sin^3\theta$, we reduce this to

$$\sin 3\theta = \underline{\hspace{2cm}}$$

so that the positive roots of (*) are the two numbers

$$z = \underline{\hspace{2cm}}, \underline{\hspace{2cm}}.$$

We obtain *two* similarity classes of triangles, respectively with angles

_____, _____, _____,

and

_____, _____, _____.

There are altogether *five* similarity classes of triangles whose three
sides and one altitude, in some order, are in arithmetic progression.

Chapter 10

The golden section

$$\varphi = \frac{\sqrt{5} + 1}{2} = 1.6180339887\dots$$

- 1 The golden triangle
 - 2 Dissection of a square
 - 3 Dissection of a rectangle
 - 4 Characterizations of the golden triangle
 - 5 What is the most non-isosceles triangle?
- Appendix: Cutting a square into three similar parts
Exercise

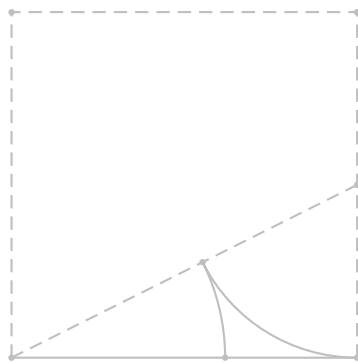

10.1 The golden section φ

A segment AB is said to be divided into the golden ratio by a point P if $AP^2 = AB \cdot PB$.

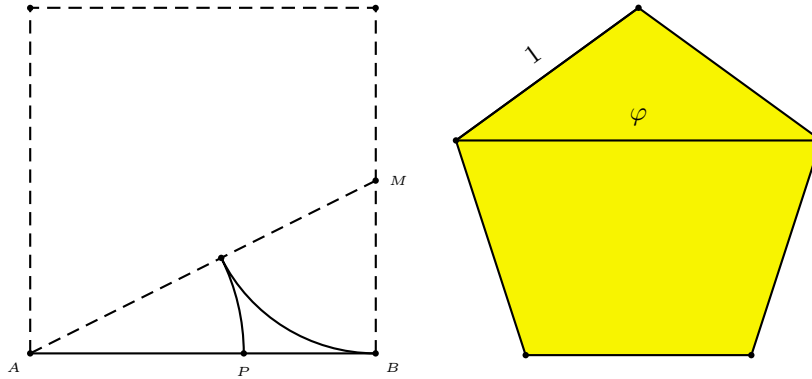

$$\frac{AB}{AP} = \varphi = \frac{\sqrt{5} + 1}{2}.$$

Some basic properties of φ

1. $\varphi^2 = 1 + \varphi$; $\frac{1}{\varphi} = \varphi - 1$.
2. The diagonal and the side of a regular pentagon are in the golden ratio.
3. The ratio of successive Fibonacci numbers tends to φ .
4. The simple continued fraction expansion of φ is

$$1 + \frac{1}{1 + \frac{1}{1 + \frac{1}{1 + \frac{1}{\ddots}}}}.$$

10.2 Dissection of a square

Show how the square should be dissected so that it can be reassembled into a rectangle.

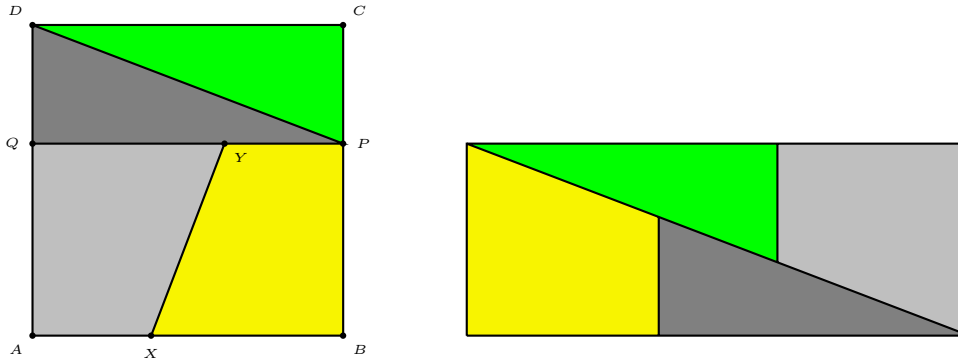

Let $AB = BC = a$. We want to find $x = AX = PC$ such that the areas of the rectangle and the square are the same.

Resolve the paradox: How can the area increase after reassembling?

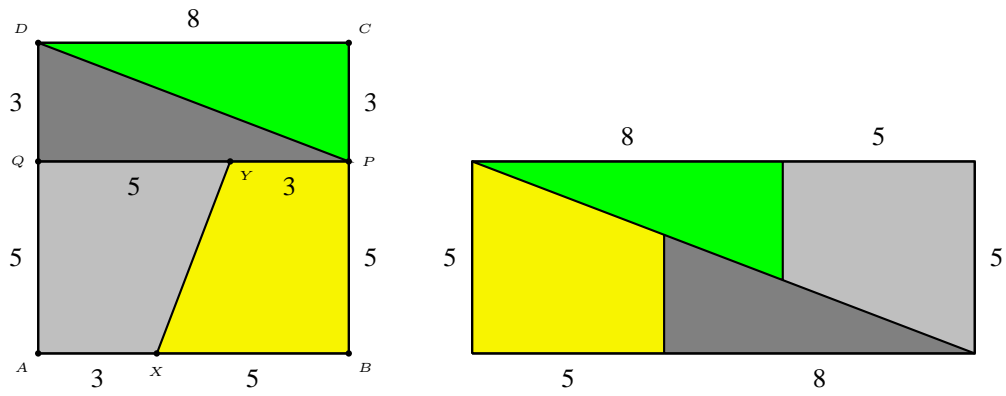

10.3 Dissection of a rectangle

Let P and Q be points on the sides AB and BC of rectangle $ABCD$.

If the areas of triangles APD , BPQ and CDQ are equal, then P and Q divide the sides in the golden ratio.

If, in addition, $DP = PQ$, then the rectangle is golden, and $\angle DPQ$ is a right angle.

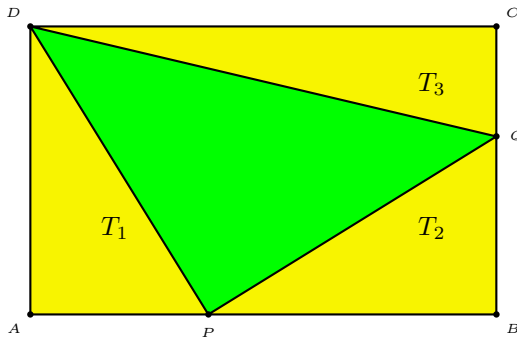

10.4 The golden right triangle

The golden right triangle is the one whose hypotenuse and one leg are in the golden ratio.

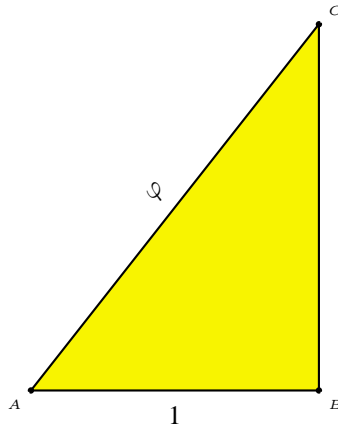

Characterizations of the golden triangle

1. If the sides of a right triangle are in geometric progression, then it is the golden triangle.
2. If the altitude of a right triangle divides the hypotenuse in the golden ratio, then the triangle is golden.
3. If one side of a right triangle is the geometric mean of the other two sides, then this is a golden right triangle.
4. If the sides of a right triangle are respectively the harmonic, geometric, and arithmetic means of two numbers, then the triangle is a golden right triangle.

Find the isosceles triangle of smallest perimeter that circumscribed a given semicircle.

Suppose the semicircle has radius 1. If θ is the base angle, the perimeter is $2(\tan \theta + \cot \theta + \csc \theta)$. We want to find the θ that minimizes this perimeter.

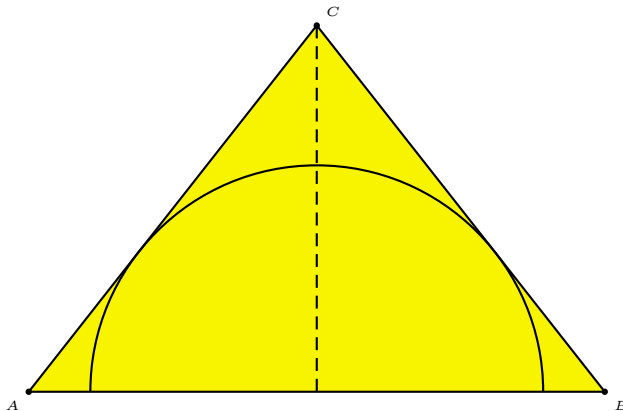

10.5 What is the most non-isosceles triangle?

Given a triangle, there are 6 ratios obtained by comparing the lengths of a pair of sides. The one which is closest to 1 is called the ratio of non-isoscelity of the triangle. Determine the range of the ratio of non-isoscelity of triangles.

Theorem 10.1. *A number η is the ratio of non-isoscelity of a triangle if and only if it lies in the interval $(\frac{1}{\varphi}, 1]$.*

Proof. First note that if $r < 1$ is the ratio of the length of two sides of a triangle, then so is $\frac{1}{r}$. Since $\frac{1}{2}(r + \frac{1}{r}) > 1$, r is closer to 1 than $\frac{1}{r}$. It follows that the ratio of non-isoscelity $\eta \leq 1$.

If $a \leq b \leq c$ are the side lengths, then $\eta = \max(\frac{a}{b}, \frac{b}{c})$. Since $a + b > c$, we have

$$\eta + 1 \geq \frac{a}{b} + 1 > \frac{c}{b} \geq \frac{1}{\eta}.$$

It follows that $\eta^2 + \eta > 1$. Since the roots of $x^2 + x - 1 = 0$ are $\frac{1}{\varphi} > 0$ and $-\varphi < 0$, we must have $\eta > \varphi - 1$. This shows that $\eta \in (\frac{1}{\varphi}, 1]$.

For each number t in this range, the triangle with sides $t, 1, \frac{1}{t}$ is one with ratio of non-isoscelity t . \square

There is therefore no “most non-isosceles” triangle. Instead, the most non-isosceles triangles almost degenerate to a segment divided in the golden ratio.

Project: Cutting a square into three similar parts

Cut a square into three similar parts, no two congruent.

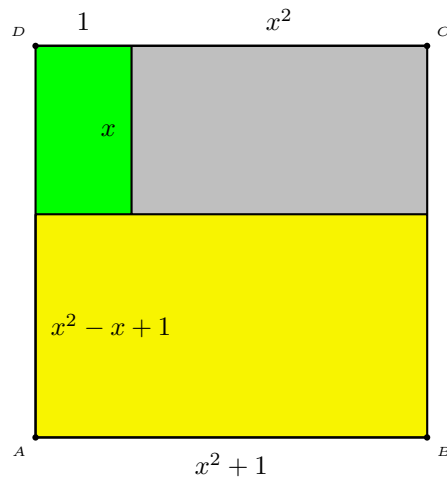

Exercise

1. Show that $\cos 36^\circ = \frac{\sqrt{5}+1}{2}$.
2. Which of the two equilateral triangles inscribed in a regular pentagon has larger area?

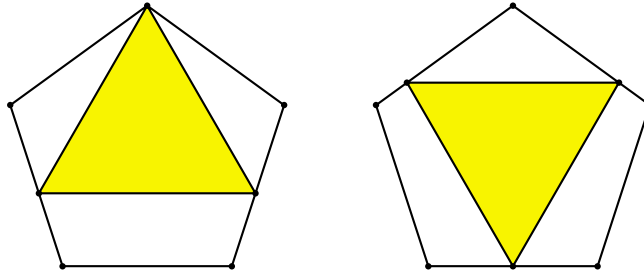

3. Which of the two squares inscribed in a regular pentagon has larger area?

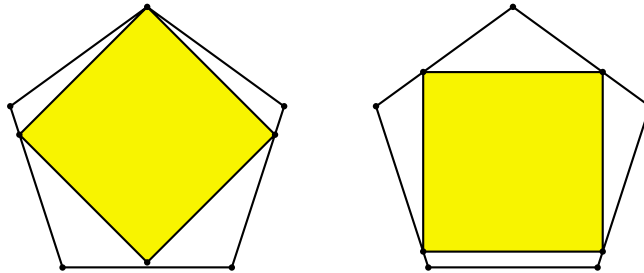

If we assume the regular pentagon inscribed in a unit circle, the side-lengths of these squares are respectively

$$\frac{\sqrt{10}}{8} (\sqrt{5} + 1)$$

and

$$\frac{\sqrt{5}}{2} \left(\sqrt{10 - 2\sqrt{5}} - \sqrt{5} + 1 \right).$$

The first square exceeds the second one by

$$\frac{1}{8} \left(20 + 5\sqrt{2} + \sqrt{10} - 4\sqrt{5} - 4\sqrt{50 - 10\sqrt{5}} \right) \approx 0.0324786 \dots$$

One of you [GC] suggested an “easy” construction of the square as follows.

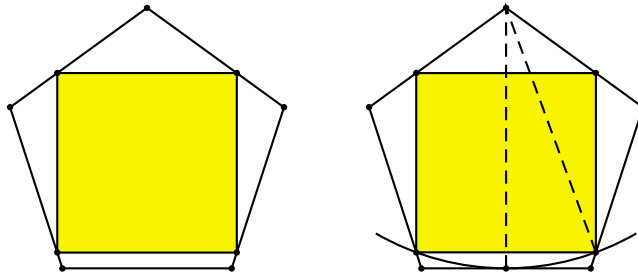

This indeed is not exact, but it gives an approximate rectangle with base

$$\frac{1}{2} \sqrt{5(2 - 2\sqrt[4]{5} + \sqrt{5})},$$

which is smaller only by 0.08%!

As for the triangles, the first one has length $\sqrt{\frac{5}{2} (4 + \sqrt{5} - \sqrt{15 + 6\sqrt{5}})}$, and the second one has shorter length $\frac{\sqrt{10}(\sqrt{5}+1)}{(\sqrt{5}-1)\sqrt{5-\sqrt{5}+2\sqrt{6}}}$. The difference between the two is approx 0.0328...

11.1 Construction of golden rectangle

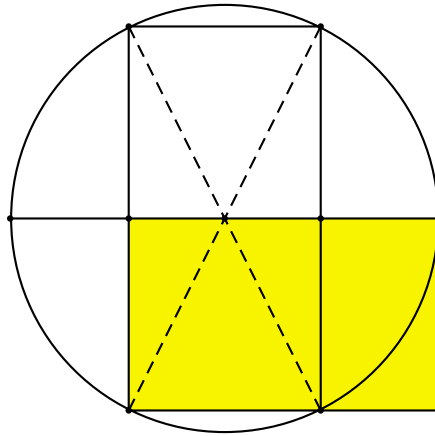

11.2 Hofstetter's compass-only construction of the golden section

Kurt Hofstetter has found the following construction of the golden section by striking the compass only five times.¹

We denote by $P(Q)$ the circle with P as center and PQ as radius. Figure 1 shows two circles $A(B)$ and $B(A)$ intersecting at C and D . The line AB intersects the circles again at E and F . The circles $A(F)$ and $B(E)$ intersect at two points X and Y . It is clear that C, D, X, Y are on a line. It is much more interesting to note that D divides the segment CX in the golden ratio, *i.e.*,

$$\frac{CD}{CX} = \frac{\sqrt{5} - 1}{2}.$$

This is easy to verify. If we assume AB of length 2, then $CD = 2\sqrt{3}$ and $CX = \sqrt{15} + \sqrt{3}$. From these,

$$\frac{CD}{CX} = \frac{2\sqrt{3}}{\sqrt{15} + \sqrt{3}} = \frac{2}{\sqrt{5} + 1} = \frac{\sqrt{5} - 1}{2}.$$

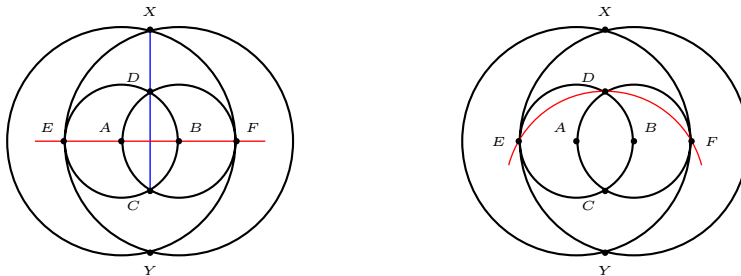

This shows that to construct three collinear points in golden section, we need four circles and one line. It is possible, however, to replace the line AB by a circle, say $C(D)$. See Figure 2. Thus, *the golden section can be constructed with compass only, in 5 steps.*

Here is a simple application: to divide a given segment into golden section.²

Construction 11.1. Given a segment AB , construct

¹K. Hofstetter, A simple construction of the golden section, *Forum Geometricorum*, 2 (2002) 65–66.

²Communicated by K. Hofstetter on December 9, 2003.

1. $\mathcal{C}_1 = A(B)$,
2. $\mathcal{C}_2 = B(A)$, intersecting \mathcal{C}_1 at C and D ,
3. CD to intersect AB at (their common midpoint) M ,
4. $\mathcal{C}_3 = A(M)$ to intersect \mathcal{C}_2 at E ,
5. $\mathcal{C}_4 = E(A)$ to intersect \mathcal{C}_3 at F and F' , F closer to M than G' ,
6. EF and extend to intersect AB at G .

The point G divides the segment AB in the golden section.

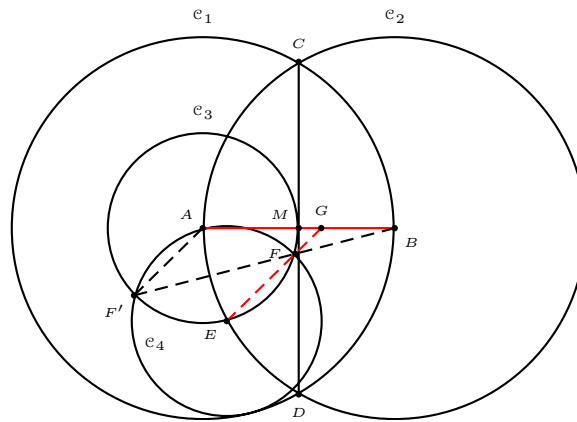

Proof. By [1], F divides $F'B$ in the golden section. Since EF is parallel to $F'A$, G divides AB in the golden section as well. \square

Remark. If the lines EF' and AB intersect at G' , then A divides $G'B$ in the golden section.

11.3 Hofstetter's 5-step division of a segment in the golden section

K. Hofstetter has also found the following parsimonious division of a given segment in the golden section.³

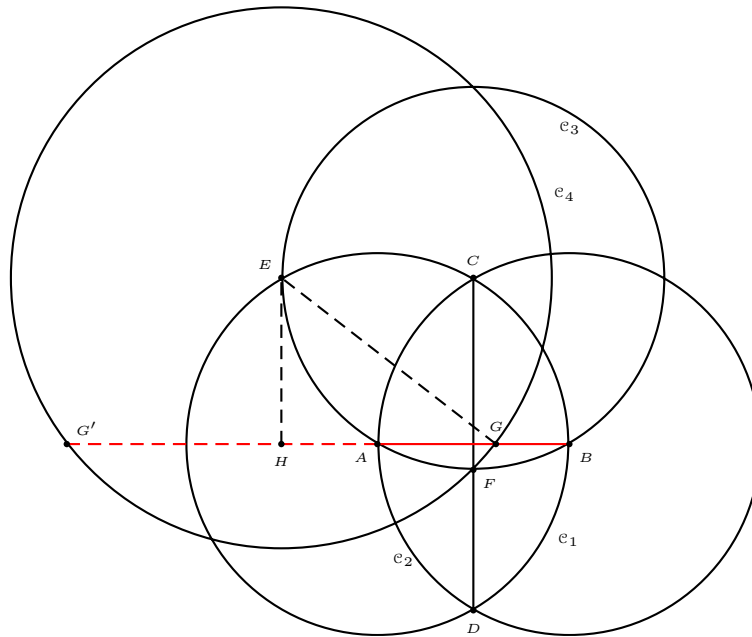

Construction 11.2. Given a segment AB , construct

1. $\mathcal{C}_1 = A(B)$,
2. $\mathcal{C}_2 = B(A)$, intersecting \mathcal{C}_1 at C and D ,
3. $\mathcal{C}_3 = C(A)$, intersecting \mathcal{C}_1 again at E ,
4. the segment CD to intersect \mathcal{C}_3 at F ,
5. $\mathcal{C}_4 = E(F)$ to intersect AB at G .

The point G divides the segment AB in the golden section.

³K. Hofstetter, A 5-step division of a segment in the golden section, *Forum Geom.*, 3 (2003) 205–206. After the publication of this paper, it was found that the same construction has been given previously by E. Lemoine, *Géométrie ou art des Constructions géométriques*, C. Naud, Paris, 1902, p.51, and J. Reusch, *Planimetrische Konstruktionen in geometrographischer Ausführung*, (Teubner 1904), pg 37.

Proof. Suppose AB has unit length. Then $CD = \sqrt{3}$ and $EG = EF = \sqrt{2}$. Let H be the orthogonal projection of E on the line AB . Since $HA = \frac{1}{2}$, and $HG^2 = EG^2 - EH^2 = 2 - \frac{3}{4} = \frac{5}{4}$, we have $AG = HG - HA = \frac{1}{2}(\sqrt{5} - 1)$. This shows that G divides AB in the golden section. \square

Remark. The other intersection G' of \mathcal{C}_4 and the line AB is such that $G'A : AB = \frac{1}{2}(\sqrt{5} + 1) : 1$.

11.4 Construction of regular pentagon

Let OA and OY be two perpendicular radii of a circle, center O .

1. Mark the midpoint M of OY and bisect angle OMA to intersect OA at P .
2. Construct the perpendicular to OA at P to intersect the circle at B and E .

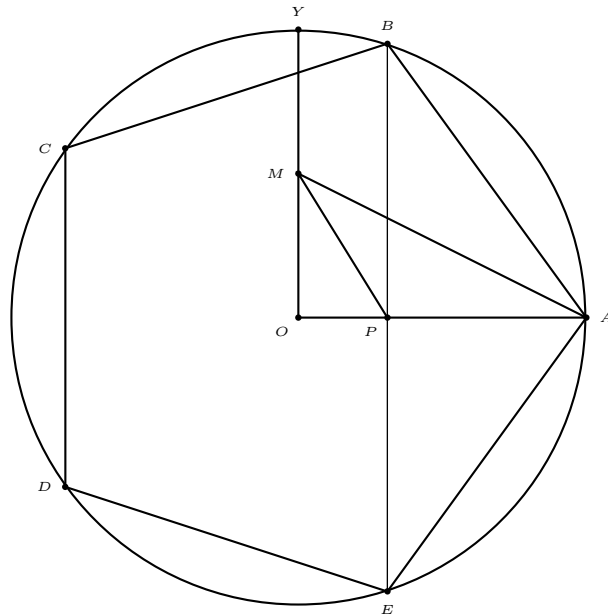

Then A , B , E are three adjacent vertices of a regular pentagon inscribed in the circle. The remaining two vertices can be easily constructed.

11.5 Ahlburg's parsimonious construction of the regular pentagon

Make use of a given right triangle $AB'C$ with $AC = 2B'C$ to construct a regular pentagon in the fewest number of euclidean operations. (Euclidean operations include (i) setting a compass, (ii) striking an arc, (iii) drawing a line.

Between the side a and the diagonal d of a regular pentagon, there is the relation $a = \frac{\sqrt{5}-1}{2}d$. Here is Hayo Ahlburg's construction. ⁴

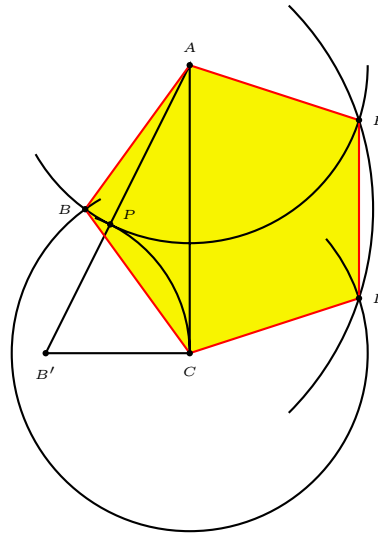

Construction 11.3. (1) Strike an arc $B'(B'C)$, that is, with center B' and radius $B'C$, meeting AB' at P .

(2) Strike an arc $A(AP)$.

(3) Strike an arc $C(AP)$, meeting arc $A(AP)$ at B .

(4) Strike an arc $B(CA)$, meeting arcs $A(AP)$ and $C(AP)$ at D and E .

Then $ABCDE$ is the required regular pentagon. The construction requires 3 compass settings, striking 4 arcs, and drawing 5 lines for the sides of the pentagon, 12 euclidean construction in all.

⁴*Cruz Math.*, 6 (1980) 50.

11.6 Construction of a regular 17-gon

To construct two vertices of the regular 17-gon inscribed in a given circle $O(A)$.

1. On the radius OB perpendicular to OA , mark a point J such that $OJ = \frac{1}{4}OA$.
2. Mark a point E on the segment OA such that $\angle OJE = \frac{1}{4}\angle OJA$.
3. Mark a point F on the diameter through A such that O is between E and F and $\angle EJF = 45^\circ$.
4. With AF as diameter, construct a circle intersecting the radius OB at K .
5. Mark the intersections of the circle $E(K)$ with the diameter of $O(A)$ through A . Label the one between O and A points P_4 , and the other and P_6 .
6. Construct the perpendicular through P_4 and P_6 to intersect the circle $O(A)$ at A_4 and A_6 .⁵

Then A_4, A_6 are two vertices of a regular 17-gon inscribed in $O(A)$. The polygon can be completed by successively laying off arcs equal to A_4A_6 , leading to $A_8, A_{10}, \dots, A_{16}, A_1 = A, A_3, A_5, \dots, A_{15}, A_{17}, A_2$.

⁵Note that P_4 is not the midpoint of AF .

Exercise

1. Let ABC be an equilateral triangle. The line joining the midpoints D, E of two sides intersects the circumcircle at F . Then E divides DF in the golden section, *i.e.*,

$$\frac{DE}{DF} = \frac{\sqrt{5} - 1}{2}.$$

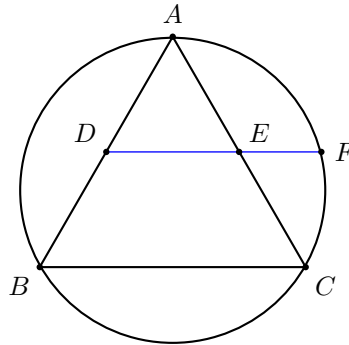

2. M is the midpoint of the side AB of a square $ABCD$. The line DM intersects the circle with diameter AB at two points, P inside and Q outside the square. Show that the rectangle $APBQ$ is a golden rectangle, *i.e.*, $PB : PA = (\sqrt{5} + 1) : 2$.

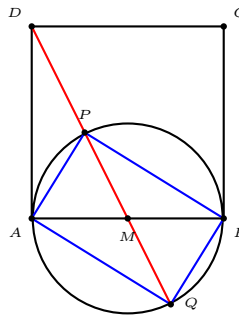

Project

This is a classic problem you should know if you teach geometry. While it is not difficult to guess what the answer is, it has been quite baffling to most people to arrive at the answer logically.

ABC is an isosceles triangle with angle $A = 20^\circ$. E and F are points on AC and AB such that $\angle EBC = 60^\circ$ and $\angle FCB = 50^\circ$. Calculate $\angle BEF$.

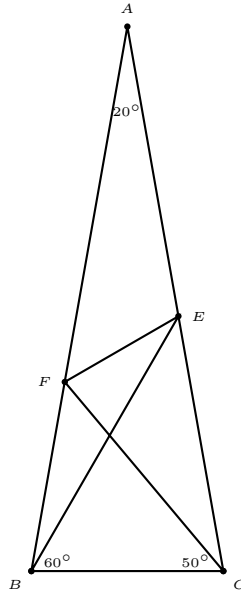

Appendix: Another construction of regular pentagon⁶

Given a circle, center O , let

- (i) AXY be an isosceles triangle whose height is $\frac{5}{4}$ of the radius of the circle,
- (ii) X', Y' be points on the circumference such that $AX' = AY' =$ radius,
- (iii) $P = AX \cap OB'$ and $Q = AY \cap OC'$,
- (iv) the line PQ intersect the circumference at B and C .

Then AB and AC are two sides of a regular pentagon inscribed in the circle.

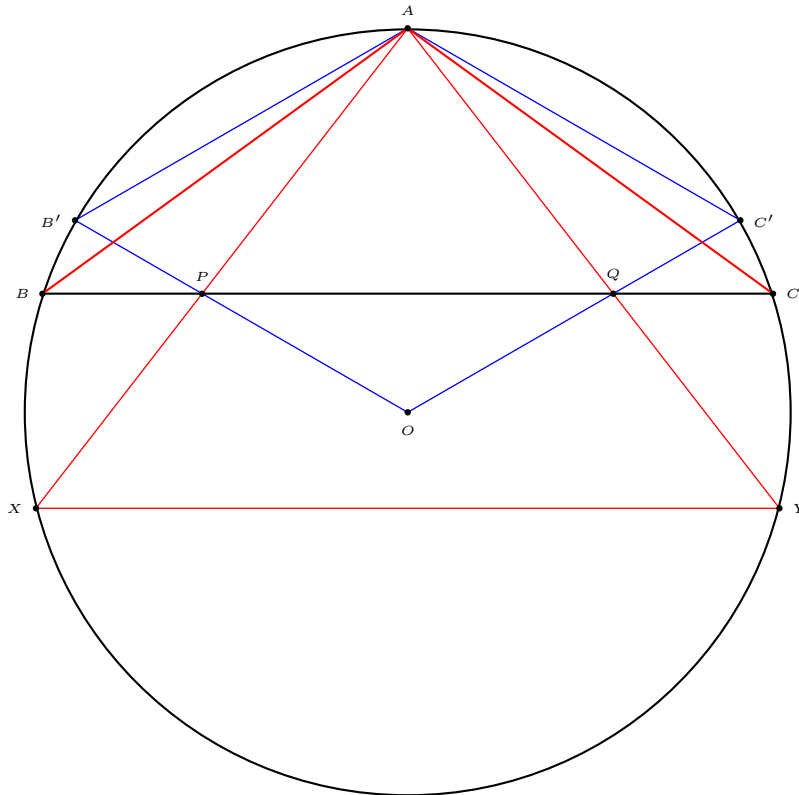

⁶D. Nelson, A regular pentagon construction, *Math. Gazette*, 61 (1977) 215–216.

$ABCDE$ is a pentagon inscribed in a circle such that $AB = CD = AE =$ the radius of the circle. P and Q are the midpoints of the sides BC and DE . Show that triangle APQ is equilateral.

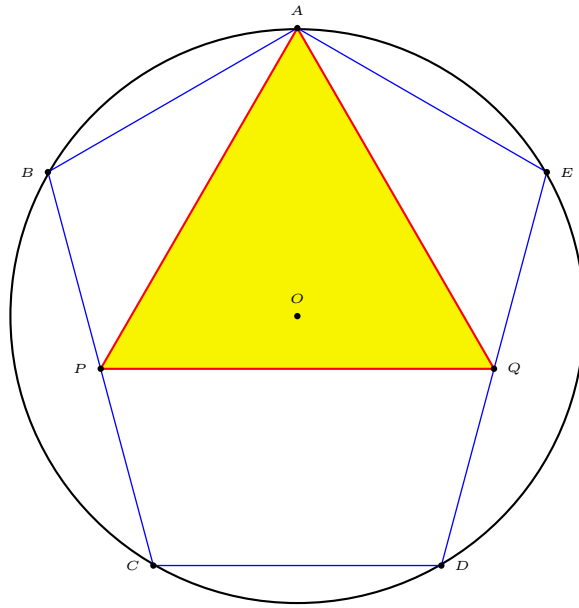

Chapter 12

Cheney's card trick

- 1 Principles
 - 2 Examples
- Exercise

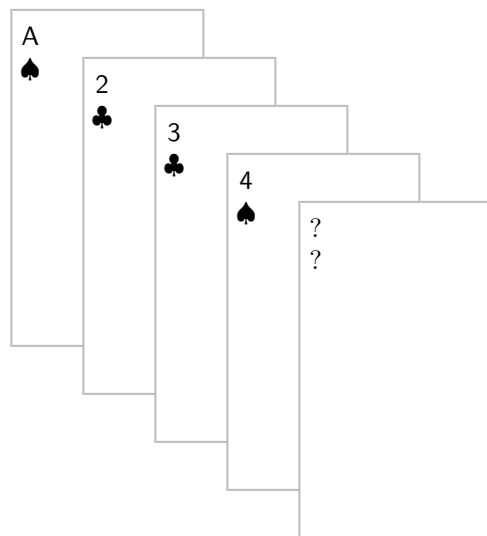

12.1 Principles

You are the magician's assistant. What he will do is to ask a spectator to give you any 5 cards from a deck of 52. You show him 4 of the cards, and in no time, he will tell everybody what the 5th card is. This of course depends on you, and you have to do things properly by making use of the following three basic principles.

1. *The pigeonhole principle.* Among 5 cards at least 2 must be of the same suit. So you and the magician agree that the secret card has the same suit as the first card.

2. *The distance of two points on a 13-hour clock is no more than 6.*

We decide which of the two cards to be shown as the first, and which to be kept secret. For calculations, we treat A, J, Q, and K are respectively 1, 11, 12, and 13 respectively.

Now you can determine the distance between these two cards. From one of these, going *clockwise*, you get to the other by travelling this distance on the 13-hour clock. Keep the latter as the secret card. Here are some examples.

hours	distance	clockwise
2 and 7	5	2 to 7
3 and 10	6	10 to 3
2 and J	4	J to 2
A and 8	6	8 to A

3. *There are 6 arrangements of three objects.*

The remaining three cards can be ordered as **small**, **medium**, and **large**.¹ Now rearrange them properly to tell the magician what number he should add (clockwise) to the first card to get the number on the secret card. Let's agree on this:

arrangement	distance
sml	1
slm	2
msl	3
mls	4
lsm	5
lms	6

¹First by numerical order; for cards with the same number, order by suits: ♣ < ♦ < ♥ < ♠.

12.2 Examples

If, for example, you, the assistant, want to tell the magician that he should add 4 to the number (clockwise) on the first card, deal the **medium** as the second card, the **large** as the third, and the **small** as the fourth card. Here are two examples.

1. Suppose you have $\spadesuit 5$, $\clubsuit 7$, $\diamond J$, $\clubsuit 4$, and $\spadesuit Q$, and you decide to use the \clubsuit cards for the first and the secret ones. The distance between $\clubsuit 7$ and $\clubsuit 4$ is of course 3, clockwise from $\clubsuit 4$ to $\clubsuit 7$. You therefore show $\clubsuit 4$ as the first card, and arrange the other three cards, $\spadesuit 5$, $\diamond J$, and $\spadesuit Q$, in the order **medium**, **small**, **large**. The second card is $\diamond J$, the third $\spadesuit 5$, and the fourth $\spadesuit Q$.

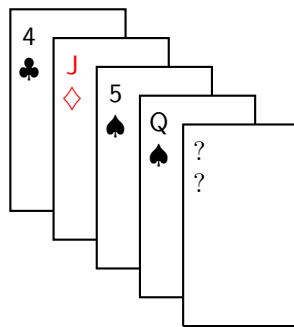

The secret card is $\clubsuit 7$.

2. Now to the magician. Suppose your assistant show you these four cards in order:

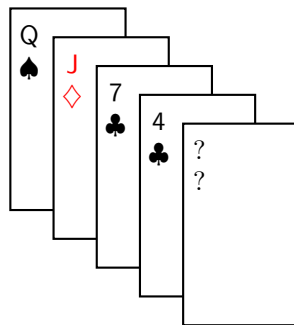

Then you know that the secret card is a \spadesuit , and you get the number by adding to Q the number determined by the order **large**, **medium**, **small**, which is 6. Going clockwise, this is 5. The secret card is $\spadesuit 5$.

Exercise

1. For the assistant:

(a) ♠5, ♠7, ♦6, ♣5, ♣Q.

(b) ♥2, ♠J, ♥K, ♣2, ♠8.

2. For the magician: what is the secret card?

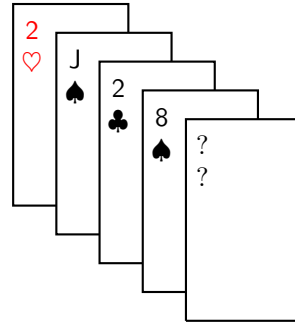
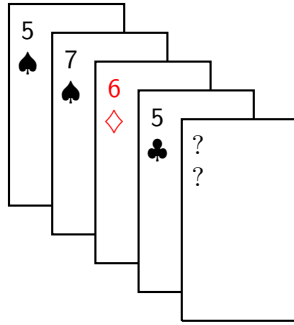

13.1 When can you cancel illegitimately and yet get the correct answer?

Let ab and bc be 2-digit numbers. When do such illegitimate cancellations as

$$\frac{ab}{bc} = \frac{a \cancel{b}}{\cancel{b} c} = \frac{a}{c}$$

give correct results in lowest terms?

How about

$$\frac{a \cancel{b} \cancel{c}}{\cancel{b} \cancel{c} d} = \frac{a}{d},$$

allowing perhaps further simplifications of $\frac{a}{d}$?

13.5 The problem of 4 n 's

$1 = \frac{n+n}{n+n}$	$13 = \frac{n}{.n} + \sqrt{\frac{n}{.n}}$
$2 = \frac{n}{n} + \frac{n}{n}$	$14 = \frac{\sqrt{n(n+n)}}{.n}$
$3 = \frac{n+n+n}{n}$	$15 = \frac{n}{.n} + \left(\sqrt{\frac{n}{.n}}\right)!$
$4 = \frac{n-.n}{.n+.n}$	$16 = \frac{n}{.n} + \left(\sqrt{\frac{n}{.n}}\right)!$
$5 = \frac{n+.n}{.n+.n}$	$17 = \frac{n+n-.n}{.n}$
$6 = \frac{(n+n+n)!}{n}$	$18 = \frac{n}{.n} + \frac{n}{.n}$
$7 = \frac{n-.n-.n}{.n}$	$19 = \frac{n}{.n} + \frac{n}{.n}$
$8 = \frac{n}{.n} - \frac{n}{n}$	$20 = \frac{n}{.n} + \frac{n}{.n}$
$9 = \frac{n}{.n} \cdot \frac{n}{n}$	$21 = \frac{n+n+.n}{.n}$
$10 = \frac{n}{.n} + \frac{n}{n}$	\vdots
$11 = \frac{n}{.n} + \frac{n}{n}$	
$12 = \frac{n+.n+.n}{.n}$	

Theorem 13.1 (Hoggatt and Moser). *Let n be any positive number different from 1 and let p be any integer greater than 3. Every integer may be expressed by using p n 's and a finite number of operator symbols used in high school texts.*

Proof. It is easily verified that for every positive integer k ,

$$\log_{\log_{\sqrt{n}} n} \log_{\sqrt{\sqrt{\dots\sqrt{n}}}} n = k,$$

$$\log_{\frac{n+n}{n}} \log_{\sqrt{\sqrt{\dots\sqrt{n}}}} n = k.$$

where the base of the second logarithms contains k square root signs. These settle the cases of 4 and 5 numbers. For higher values of p , add an appropriate numbers of $(n - n) + \dots + (n - n)$. \square

Appendix: Squares with 9 distinct nonzero digits

11826	139854276	12363	152843769	12543	157326849	14676	215384976
15681	245893761	15963	254817369	18072	326597184	19023	361874529
19377	375468129	19569	382945761	19629	385297641	20316	412739856
22887	523814769	23019	529874361	23178	537219684	23439	549386721
24237	587432169	24276	589324176	24441	597362481	24807	615387249
25059	627953481	25572	653927184	25941	672935481	26409	697435281
26733	714653289	27129	735982641	27273	743816529	29034	842973156
29106	847159236	30384	923187456				

Appendix: Squares with 10 distinct digits

32043	1026753849	32286	1042385796	33144	1098524736	35172	1237069584
35337	1248703569	35757	1278563049	35853	1285437609	37176	1382054976
37905	1436789025	38772	1503267984	39147	1532487609	39336	1547320896
40545	1643897025	42744	1827049536	43902	1927385604	44016	1937408256
45567	2076351489	45624	2081549376	46587	2170348569	48852	2386517904
49314	2431870596	49353	2435718609	50706	2571098436	53976	2913408576
54918	3015986724	55446	3074258916	55524	3082914576	55581	3089247561
55626	3094251876	56532	3195867024	57321	3285697041	58413	3412078569
58455	3416987025	58554	3428570916	59403	3528716409	60984	3719048256
61575	3791480625	61866	3827401956	62679	3928657041	62961	3964087521
63051	3975428601	63129	3985270641	65634	4307821956	65637	4308215769
66105	4369871025	66276	4392508176	67677	4580176329	68763	4728350169
68781	4730825961	69513	4832057169	71433	5102673489	72621	5273809641
75759	5739426081	76047	5783146209	76182	5803697124	77346	5982403716
78072	6095237184	78453	6154873209	80361	6457890321	80445	6471398025
81222	6597013284	81945	6714983025	83919	7042398561	84648	7165283904
85353	7285134609	85743	7351862049	85803	7362154809	86073	7408561329
87639	7680594321	88623	7854036129	89079	7935068241	89145	7946831025
89355	7984316025	89523	8014367529	90144	8125940736	90153	8127563409
90198	8135679204	91248	8326197504	91605	8391476025	92214	8503421796
94695	8967143025	95154	9054283716	96702	9351276804	97779	9560732841
98055	9614783025	98802	9761835204	99066	9814072356		

Exercise

1. Lucky Larry, a mathematics student whose plausible mistakes in computation always results in correct answers, once wrote an answer in the form

$$a^b c^a = abca$$

where $abca$ represents a four-digit integer whose digits a, b, c are all different. What specific number did Lucky Larry write?

2. Find all natural numbers whose square (in base 10) is represented by odd digits only.
3. Let N be the sum of the digits of a natural number A , let $B = A + N$, let A' be the sum of the digits of the number B , and let $C = B + A'$. Find A if the digits of C are those of A in reverse order.

Solution. If A has k digits, then C cannot exceed A by more than $18k$. On the other hand, if C is the reverse of A , then C exceeds A by at least $9 \cdot 10^{\frac{k-2}{2}}$ if k is even, and by at least $99 \cdot 10^{\frac{k-3}{2}}$ if k is odd. This quickly implies $k \leq 2$. From this, we find $A = 12$ or 69 .

4. Find the three 3-digit numbers each of which is equal to the product of the sum of its digits by the sum of the squares of its digits.
5. Find all 4-digit numbers $abcd$ such that $\sqrt[3]{abcd} = a + b + c + d$.
6. Use each digit 1, 2, 3, 4, 5, 6, 7, 8, 9 exactly once to form prime numbers whose sum is smallest possible.

What if we also include the digit 0?

7. There are exactly four 3-digit numbers each equal to the sum of the cubes of its own digits. Three of them are 153, 371, and 407. What is the remaining one?
8. Find digits m, a, b, c, d, e, f such that

$$\frac{abcdef}{fedcba} = \frac{9m}{9m+1}$$

9. Find a number of the form $aaabbbccc$, which when increased by 1, gives a square.

- 10.** Here are seven consecutive squares for each of which its decimal digits sum to a square:

81, 100, 121, 144, 169, 196, 225.

Find another set of seven consecutive squares with the same property. ¹

- 11.** Find a perfect square of 12 digits formed from the juxtaposition of two squares, one having 4 digits and the other 8 digits.
- 12.** A pandigital number is one whose decimal representation contains all digits 0, 1, ..., 9. There are three pandigital perfect squares whose square roots are palindromes. Find them.
- 13.** Find the smallest 3-digit number N such that the three numbers obtained by cyclic permutations of its digits are in arithmetic progression.
- 14.** Form a square of 8 digits which is transformed into a second square when the second digit from the left is increased by 1.
- 15.** The number $(abbbb)^2 - 1$ has 10 digits, all different. Find the number. ²

¹The seven numbers beginning with 9999.

²These are the only possibilities even if we consider more generally numbers consisting of two consecutive blocks of repeating digits, whose squares, to within ± 1 , contain all ten digits without repetition.

Charles Twigg's square number trivia

What three-digit squares have the following characteristics?

1. are palindromes.
2. are permutations of consecutive digits.
3. form reversal pairs.
4. are three permutations of the same digit set.
5. three of its permutations are prime.
6. the sum of the digits is 19.
7. is also a cube.
8. the central digit is perfect.
9. are composed of even digits.
10. the central digit is a nonzero cube.

Cross number puzzle

Place 13 three - digit square numbers in the spaces in the accompanying grid. (The solution is unique).

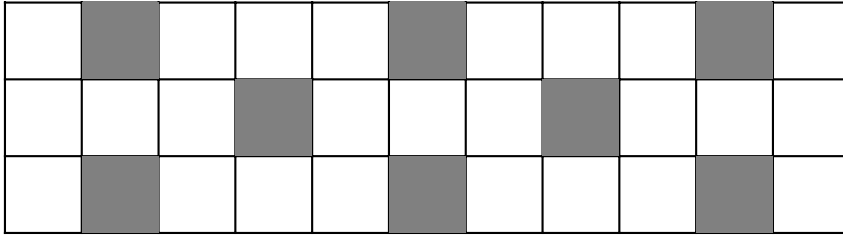

Project

Arrange the ten digits (0, 1, . . . , 9, no repetition) in a row

$$abcdefghij$$

so that the following 3-digit numbers in the table below are divisible by the prime below them.

$$\begin{array}{ccccccc} bcd & cde & def & efg & fgh & ghi & hij \\ \hline 2 & 3 & 5 & 7 & 11 & 13 & 17 \end{array}$$

Solution: 1460357289 or 4160357289

Since def is divisible by 5, f must be 0 or 5. Now, the number fgh must be divisible by 11. The only number that can be formed from the first two digits of $13m$ by appending a 0 or a 5 on the left to form a multiple of 11 are 286, 390, 728, and 832. Clearly, $f = 5$, and $fghi$ is only one of

$$5286, 5390, 5728, 5832.$$

Now we want to find a multiple of 17 beginning with the last two digits of these. This eliminates the last case.

$$52867, 53901, 57289.$$

Since efg is a multiple of 7, $\text{mod}(e, 7)$ must satisfy $2 \text{ mod } (e, 7) + \text{mod}(10f + g, 7) \equiv 0 \text{ mod } 7$. Necessarily, $e = 2, 1, 3$. Now we must have $efghij = 357289$.

Now it remains to arrange 0, 1, 4, 6 as a, b, c, d such that the three digit numbers $bcd, cd3$ are 3 digit numbers divisible by 2, 3 respectively. In particular, $c + d + 3$ is divisible by 3. The only choice is $c = 6$ and $d = 0$. We have $ab60357289$. a and b can be 1, 4 or 4, 1.

Chapter 14

Numbers with many repeating digits

- 1 A quick multiplication
 - 2 The repunits
 - 3 Squares of repdigits
 - 4 Sorted numbers with sorted squares
- Appendix: Factorization of $10^n + 1$ for $n \leq 50$
Exercise

14.1 A quick multiplication

What is the smallest positive integer with the property that when the digit 1 is appended to both ends, the new number is 99 times the original?

Suppose the number X has n digits. We require $10^n + 10X + 1 = 99X$ or $89X = 10^n + 1$. Note that 89 is prime. To find the smallest n we divide 89 into the number 1 followed by a string of zeros, extended if necessary, until a remainder 80 occurs. Then add 1 and obtain an integer quotient which is the smallest possible X .

The first time this occurs is at the 22nd zero. Thus, the smallest possible value of X is

$$\frac{10^{22} + 1}{89} = 112359550561797752809.$$

For this value of X we have

$$99 \times 112359550561797752809 = 11123595505617977528091.$$

See Appendix for the factorization of numbers of the form $10_{n-1}1$.

14.2 The repunits

The repunit R_n is the number whose decimal representation consists of a string of n ones. Thus, $R_n = 1_n$.

Notations

$$\mathbf{A} := 123456790,$$

$$\mathbf{B} := 098765432,$$

$$\overline{\mathbf{1}}_k := 1_{k-1},$$

$$\overline{\mathbf{2}}_k := 12_k,$$

$$\overline{\mathbf{m}}_k := 12 \cdot (m-1)m_k(m-1) \cdots 2, \quad \text{for } 3 \leq m \leq 9.$$

Theorem 14.1. *Let $p = 9k + m$, $k \geq 0$, $1 \leq m \leq 9$. For $q \geq p$,*

$$R_p R_q = \mathbf{A}_k \overline{\mathbf{m}}_{q-p+1} \mathbf{B}_k 1.$$

In particular,

$$(R_p)^2 = \mathbf{A}_k \overline{\mathbf{m}} \mathbf{B}_k 1.$$

14.3 Squares of repdigits

In the decimal representations of integers, we write a_n for a string of n digits each equal to a .

Theorem 14.2. For $n \geq 2$,

$$(3_n)^2 = 1_{n-1}08_{n-1}9,$$

$$(6_n)^2 = 4_{n-1}35_{n-1}6,$$

$$(9_n)^2 = 9_{n-1}89_{n-1}1.$$

Proof. The last one is easiest.

$$\begin{aligned} (9_n)^2 &= (10^n - 1)^2 \\ &= 10^{2n} - 2 \cdot 10^n + 1 \\ &= 10^n(10^n - 2) + 1 \\ &= 9_{n-1}80_{n-1}1. \end{aligned}$$

From this we obtain the square of 3_n by division by 9, then the square of 6_n by multiplication by 4. \square

Theorem 14.3. Let $n = 9k + m$, $k \geq 0$, $1 \leq m \leq 9$. For $a = 1, 2, 4, 5, 7, 8$,

$$(aR_n)^2 = \mathbf{A}_k \overline{\mathbf{m}} \mathbf{B}_k c,$$

where \mathbf{A} , \mathbf{B} and c are given by

a	\mathbf{A}	\mathbf{B}	c
1	123456790	098765432	1
2	493827160	395061728	4
4	197530864	580246913	5
5	308641975	469135802	6
7	604938271	839506172	9
8	790123456	320987654	4

and \mathbf{m} is given by

a	1	2	3	4	5	6	7	8	9
1		12	1232	123432	12345432	1234565432	123456765432	12345678765432	1234567898765432
2		48	4928	493728	49381728	4938261728	493827061728	49382715061728	4938271595061728
4	1	193	19713	1974913	197526913	19753046913	1975308246913	197530860246913	19753086380246913
5	2	302	30802	3085802	308635802	30864135802	3086419135802	308641969135802	30864197469135802
7	4	592	60372	6048172	604926172	60493706172	6049381506172	604938259506172	60493827039506172
8	6	774	78854	7899654	790107654	79012187654	7901232987654	790123440987654	79012345520987654

14.4 Sorted numbers with sorted squares

A number is *sorted* if its digits are nondecreasing from left to right. It is strongly sorted if its square is also sorted. It is known that the only strongly sorted integers are given in the table below.¹

- 1, 2, 3, 6, 12, 13, 15, 16, 38, 116, 117.
- 16_n7 .
- 3_n4 .
- 3_n5 .
- 3_m6_n7 .

$$\begin{aligned}
 (3_n5_1)^2 &= (10 \cdot 3_n + 5)^2 \\
 &= 100 \cdot (3_n)^2 + 100 \cdot (3_n) + 25 \\
 &= 1_{n-1}08_{n-1}9_10_2 + 3_n25 \\
 &= 1_{n-1}12_{n-1}225 \\
 &= 1_n2_{n+1}5.
 \end{aligned}$$

If $x = 3_m6_n7$, then $3x = 10_{m-1}10_n1$, and it is easy to find its square.

$$(3_m6_n7)^2 = \begin{cases} 1_m3_m4_{n-m+1}6_m8_n9, & \text{if } n+1 \geq m, \\ 1_m3_{n+1}5_{m-n-1}6_{n+1}8_n9, & \text{if } n+1 < m. \end{cases}$$

More generally, the product of any two numbers of the form 3_m6_n7 is sorted.

¹Problem 1234, *Math. Mag.*, 59 (1986) 1, solution, 60 (1987)1. See also R. Blecksmith and C. Nicol, Monotonic numbers, *Math. Mag.*, 66 (1993) 257–262.

Appendix: Factorization of $10^n + 1$ for $1 \leq n \leq 50$

n	Factorization of $10^n + 1$
1	11
2	101
3	$7 \times 11 \times 13$
4	73×137
5	11×9091
6	101×9901
7	11×909091
8	17×5882353
9	$7 \times 11 \times 13 \times 19 \times 52579$
10	$101 \times 3541 \times 27961$
11	$11^2 \times 23 \times 4093 \times 8779$
12	$73 \times 137 \times 99990001$
13	$11 \times 859 \times 1058313049$
14	$29 \times 101 \times 281 \times 121499449$
15	$7 \times 11 \times 13 \times 211 \times 241 \times 2161 \times 9091$
16	$353 \times 449 \times 641 \times 1409 \times 69857$
17	$11 \times 103 \times 4013 \times 21993833369$
18	$101 \times 9901 \times 999999000001$
19	$11 \times 909090909090909091$
20	$73 \times 137 \times 1676321 \times 5964848081$
21	$7^2 \times 11 \times 13 \times 127 \times 2689 \times 459691 \times 909091$
22	$89 \times 101 \times 1052788969 \times 1056689261$
23	$11 \times 47 \times 139 \times 2531 \times 549797184491917$
24	$17 \times 5882353 \times 999999900000001$
25	$11 \times 251 \times 5051 \times 9091 \times 78875943472201$
26	$101 \times 521 \times 1900381976777332243781$
27	$7 \times 11 \times 13 \times 19 \times 52579 \times 70541929 \times 14175966169$
28	$73 \times 137 \times 7841 \times 127522001020150503761$
29	$11 \times 59 \times 154083204930662557781201849$
30	$61 \times 101 \times 3541 \times 9901 \times 27961 \times 4188901 \times 39526741$
31	$11 \times 909090909090909090909090909091$
32	$19841 \times 976193 \times 6187457 \times 834427406578561$
33	$7 \times 11^2 \times 13 \times 23 \times 4093 \times 8779 \times 599144041 \times 183411838171$
34	$101 \times 28559389 \times 1491383821 \times 2324557465671829$
35	$11 \times 9091 \times 909091 \times 4147571 \times 265212793249617641$
36	$73 \times 137 \times 3169 \times 98641 \times 99990001 \times 3199044596370769$
37	$11 \times 7253 \times 422650073734453 \times 296557347313446299$
38	$101 \times 722817036322379041 \times 1369778187490592461$
39	$7 \times 11 \times 13^2 \times 157 \times 859 \times 6397 \times 216451 \times 1058313049 \times 388847808493$
40	$17 \times 5070721 \times 5882353 \times 19721061166646717498359681$
41	$11 \times 2670502781396266997 \times 3404193829806058997303$
42	$29 \times 101 \times 281 \times 9901 \times 226549 \times 121499449 \times 4458192223320340849$
43	$11 \times 57009401 \times 2182600451 \times 7306116556571817748755241$
44	$73 \times 137 \times 617 \times 16205834846012967584927082656402106953$
45	$7 \times 11 \times 13 \times 19 \times 211 \times 241 \times 2161 \times 9091 \times 29611 \times 52579$ $\times 3762091 \times 8985695684401$
46	$101 \times 1289 \times 18371524594609 \times 4181003300071669867932658901$
47	$11 \times 6299 \times 4855067598095567 \times 297262705009139006771611927$
48	$97 \times 353 \times 449 \times 641 \times 1409 \times 69857 \times 206209 \times 66554101249 \times 75118313082913$
49	$11 \times 197 \times 909091 \times 5076141624365532994918781726395939035533$
50	$101 \times 3541 \times 27961 \times 60101 \times 7019801 \times 14103673319201 \times 1680588011350901$

Exercise

1. Show that

$$\frac{16_n}{6_n4} = \frac{1}{4}, \quad \frac{19_n}{9_n5} = \frac{1}{5}, \quad \frac{26_n}{6_n5} = \frac{2}{5}, \quad \frac{49_n}{9_n8} = \frac{4}{8}.$$

2. Show that $(16_n7)^2 = 27_n8_{n+1}9$.

3. $(3_n4)^2 = 1_{n+1}5_n6$.

4. John shook its head. “Multiply that huge number by 8 in my head? You’ve got to be kidding.”

“But it’s easy, Dad.” Mike told him. “You just shift its last digit to the front.”

The boy was right, and it is the smallest number for which it works.

What was the number?

5. John looked over his son’s shoulder. “That must be an interesting number,” he said. “Homework?”

“Just fun, Dad,” Doug replied. “It’s the serial number on that clock you brought back from Kaloat, and I’ve just noticed something special about it. If you take the last two digits and put them in front, you get exactly four times the original number, and it’s the smallest number that works that way.”

What was the serial number?

6. Given an integer n . Show that an integer can always be found which contains only digits 0 and 1 (in the decimal scale) and which is divisible by n .²

7. Determine an n -digit number such that the number formed by reversing the digits is nine times the original number. What other numbers besides nine are possible?

8. Write $5_29_{n-2}893_{n-1}9$ as a sum of three squares of natural numbers.

9. There are only two repdigits a_n whose squares have digital sum 37. What are these?³

²AMM Problem 4281.

³Answer: 1^2 and 17^2 .

Chapter 15

Digital sum and digital root

- 1 Digital sum sequences
 - 2 Digital root
 - 3 Digital roots of the powers of 2
 - 4 Digital root sequences
- Exercise

15.1 Digital sum sequences

The digital sum of a positive integer n is the sum of the digits of n . We denote this by $d(n)$.

Given a positive integer a , the digit sum sequence $\mathcal{S}(a) = (a_n)$ is defined recursively by

$$a_{n+1} = a_n + d(a_n), \quad a_1 = a.$$

Here are the first few digit sum sequences:

$$\begin{aligned} \mathcal{S}(1) & 1, 2, 4, 8, 16, 23, 28, 38, 49, 62, 70, 77, 91, 101, 103, 107, \dots \\ \mathcal{S}(3) & 3, 6, 12, 15, 21, 24, 30, 33, 39, 51, 57, 69, 84, 96, 111, 114, \dots \\ \mathcal{S}(5) & 5, 10, 11, 13, 17, 25, 32, 37, 47, 58, 71, 79, 95, 109, 119, 130, \dots \\ \mathcal{S}(7) & 7, 14, 19, 29, 40, 44, 52, 59, 73, 83, 94, 107, 115, 122, 127, 137, \dots \\ \mathcal{S}(9) & 9, 18, 27, 36, 45, 54, 63, 72, 81, 90, 99, 117, 126, 135, 144, 153, \dots \end{aligned}$$

Note that they are quite similar to the digital root sequences.

Show that $\mathcal{S}(3) = \mathcal{R}(3)$ and $\mathcal{R}(9) = \mathcal{S}(9)$.

What is the smallest number that does not appear in any of these digit sum sequences?

Find the first 10 terms of the digital sum sequence beginning with this number.

$$20, 22, 26, 34, 41, 46, 56, 67, 80, 88, 104, 109, 119, 130, 134, 142, \dots$$

Find the next smallest number which is not in any of the 6 digit sum sequences and generate a new digit sum sequence from it.

$$31, 35, 43, 50, 55, 65, 76, 89, 106, 113, 118, 128, 139, 152, 160, 167, \dots$$

There are infinitely many digit sum sequences because there are infinitely many numbers which are not of the form $n + d(n)$.

The number 101 is $n + d(n)$ for $n = 91$ and 100.

The number 101 traces back to 100, 86 which is a starter. It also traces back to 91, and eventually 1.

Here are the numbers below 100 which are not of this form:

$$1, 3, 5, 7, 9, 20, 31, 42, 53, 64, 75, 86, 97.$$

An infinite sequence of “starters”: $10_n 122$, $n \geq 1$. Every number $n \leq 10_n 114$ has $n + d(n) \leq 10_n 121$; every number $n \geq 10_n 115$ has $d(n) \geq 10_n 123$.

15.2 Digital root

Given a positive integer n , let $d(n)$ be the sum of the digits of n . If the operation d is repeated indefinitely, it stabilizes after a finite number of steps and yield a number between 1 and 9, which we call the digital root of n , denoted $D(n)$. See [Dudeny, *Amusements*, p.157].

Theorem 15.1. **1.** $D(m + n) = D(D(m) + D(n))$.

2. $D(mn) = D(D(m)D(n))$.

3. $D(m^n) = D(D(m)^n)$.

4. $D(D(n)) = D(n)$.

5. $D(n + 9) = D(n)$.

6. $D(9n) = 9$.

Proof. (5) $D(n + 9) = D(D(n) + D(9)) = D(D(n) + 9) = D(n)$ since $D(n)$ is a single-digit number.

(6) $D(9n) = D(9D(n)) = 9$ since $D(n)$ has one single digit. \square

15.3 The digital roots of the powers of 2

n	0	1	2	3	4	5	6
2^n	1	2	4	8	16	32	64
$D(2^n)$	1	2	4	8	7	5	1

It follows that the sequence of digital roots of 2^n is periodic with period 6.

	sequence of digital roots
2^n	1, 2, 4, 8, 7, 5
3^n	1, 3, $\bar{9}$
4^n	$\overline{1, 4, 7}$
5^n	$\overline{1, 5, 7, 8, 4, 2}$
6^n	$\overline{1, 6, \bar{9}}$
7^n	$\overline{1, 7, 4}$
8^n	$\overline{1, \bar{8}}$
9^n	1, $\bar{9}$

The sequence of the digital roots of $2^n + 1$ is also periodic with period 6:

$$2, 3, 5, 9, 8, 6, \dots$$

Digital roots of Fermat numbers

To find the digital root of the Fermat number $F_k = 2^{2^k} + 1$, we need only find $2^k \pmod{6}$. Now, it is clear that $2^k \equiv 1$ or $2 \pmod{3}$ according as k is even or odd. Therefore, $2^k \equiv 4$ or $\pmod{6}$ according as k is even or odd. From this, we have

$$D(F_k) = \begin{cases} 8 & \text{if } k \equiv 0 \pmod{2}, \\ 5 & \text{if } k \equiv 1 \pmod{2}. \end{cases}$$

The digital roots of the Fibonacci numbers form a sequence of period 24:

$$1, 1, 2, 3, 5, 8, 4, 3, 7, 1, 8, 9, 8, 8, 7, 6, 4, 1, 5, 6, 2, 8, 1, 9, 1, 1, \dots$$

15.4 Digital root sequences

A digit root sequence (a_n) is defined recursively by

$$a_{n+1} = a_n + D(a_n), \quad a_1 = a.$$

The digital root sequence beginning with 1 is

$$1, 2, 4, 8, 16, 23, 28, 29, 31, 35, 43, 50, 55, 56, 58, 62, 70, \dots$$

Obviously, the digital root sequence beginning with any of these terms is a subsequence of this. By taking a term not in this sequence we generate a new one. Here are five digital root sequences with initial terms 1, 3, 5, 7, 9.

$$\begin{aligned} \mathcal{R}(1) & 1, 2, 4, 8, 16, 23, 28, 29, 31, 35, 43, 50, 55, 56, 58, 62, 70, 77, 82, 83, 85, 89, 97, 104, \dots \\ \mathcal{R}(3) & 3, 6, 12, 15, 21, 24, 30, 33, 39, 42, 48, 51, 57, 60, 66, 69, 75, 78, 84, 87, 93, 96, 102, \dots \\ \mathcal{R}(5) & 5, 10, 11, 13, 17, 25, 32, 37, 38, 40, 44, 52, 59, 64, 65, 67, 71, 79, 86, 91, 92, 94, 98, 106, \dots \\ \mathcal{R}(7) & 7, 14, 19, 20, 22, 26, 34, 41, 46, 47, 49, 53, 61, 68, 73, 74, 76, 80, 88, 95, 100, \dots \\ \mathcal{R}(9) & 9, 18, 27, 36, 45, 54, 63, 72, 81, 90, 99, 108, 117, 126, 135, 144, 153, \dots \end{aligned}$$

Theorem 15.2 (Kumar). **1.** *The digital roots of these sequences are periodic.*

2. *These five sequences partition the natural numbers.*

The digital roots of these sequences are

$$\begin{aligned} R_1 & \overline{1, 2, 4, 8, 7, 5} \\ R_3 & \overline{3, 6} \\ R_5 & \overline{5, 1, 2, 4, 8, 7} \\ R_7 & \overline{7, 5, 1, 2, 4, 8} \\ R_9 & \overline{9} \end{aligned}$$

Exercise

1. A Filzian number is one which is the product of its digits and digital sum. For example, $144 = 1 \cdot 4 \cdot 4(1 + 4 + 4)$. Find one more such number.¹
2. Find the digital root of $n!$.
3. Find the digital root sequence of n^2 .
4. The cubes.
5. The triangular numbers.
6. Find all integers n such that the sum of the digits of n^2 is equal to n , i.e., $d(n^2) = n$.
7. What is the digital root of a number of the form $2^{n-1}(2^n - 1)$?

¹Answer: 135. It is known that there are only finitely many Filzian numbers. Apart from 1 and 144, the other known one is 135.

Project: Sum of squares of digits

Let $f(n)$ be sum of the squares of the digits of n . For example, $f(1) = 1$, $f(2) = 4$, $f(10) = 1$, $f(12) = 5$, $f(123) = 14$ etc.

Study the iterations of f .

For example, the iterations of f beginning with 4 leads to the cycle

$$4 \rightarrow 16 \rightarrow 37 \rightarrow 58 \rightarrow 89 \rightarrow 145 \rightarrow 42 \rightarrow 20 \rightarrow 4.$$

Chapter 16

3-4-5 triangles in the square

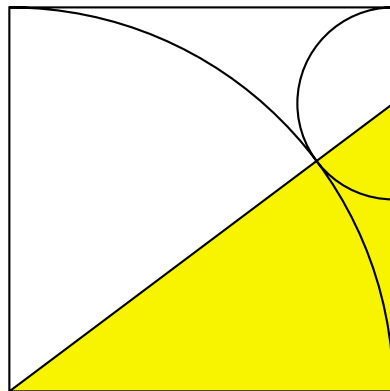
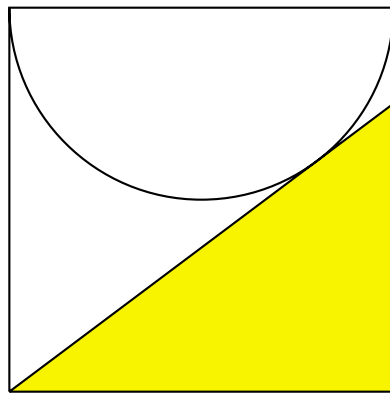

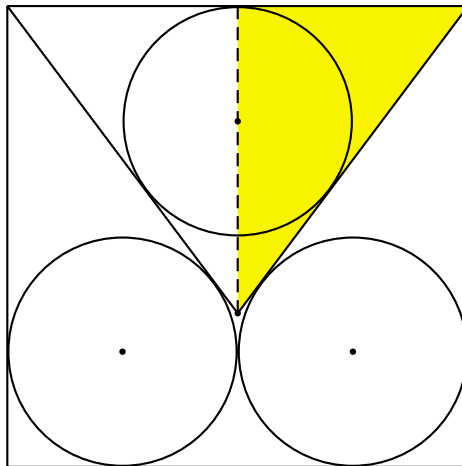
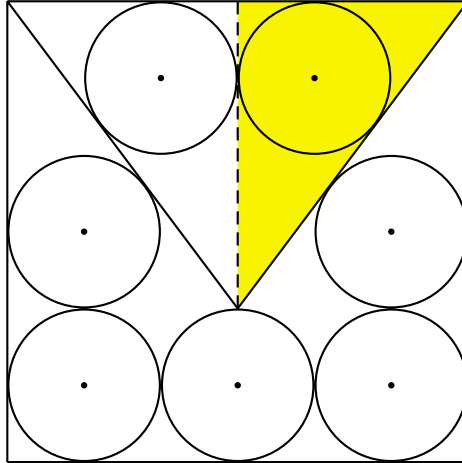

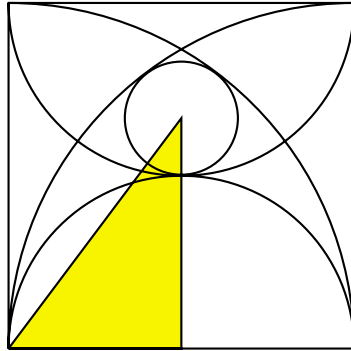
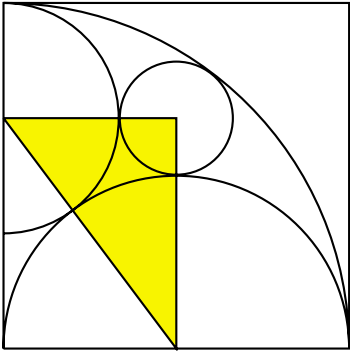
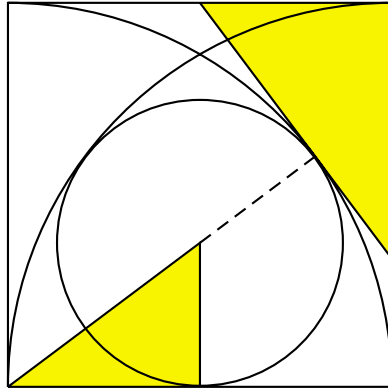
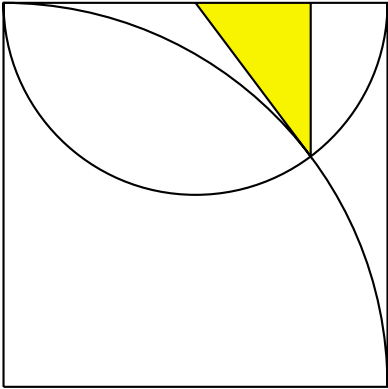

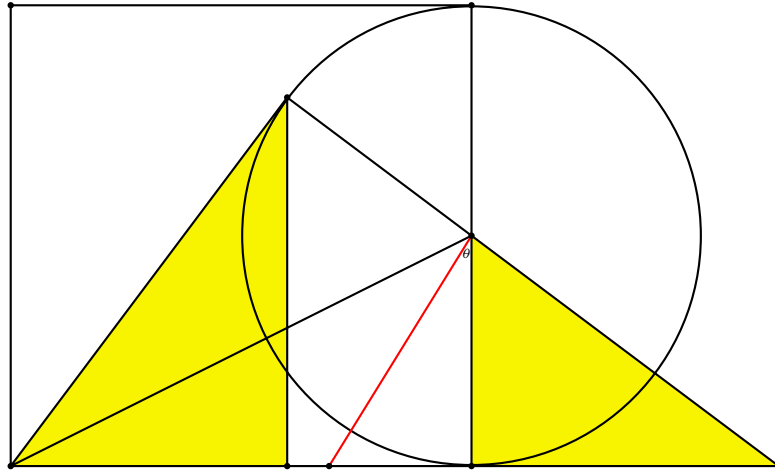

$$\tan \theta = \frac{1}{\varphi}.$$

Exercise

1. Show that the shaded triangle is a 3:4:5 triangle.

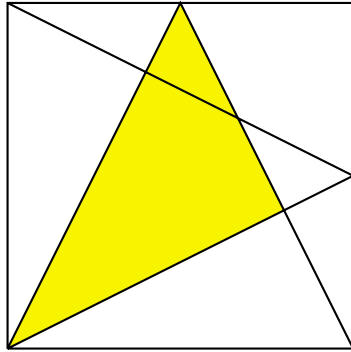

2. Find the ratio of the areas of ABY , $BCXY$, and AXD .

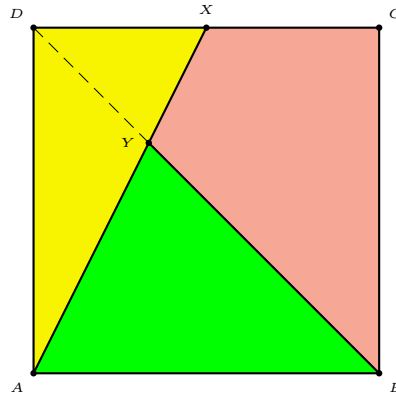

Chapter 17

Combinatorial games

- 1 Subtraction games
- 2 The nim sum
- 2 Nim
- 3 Northcott's variation of nim
- 4 Wythoff's game
- Appendix: Beatty's theorem
- Exercise
- Project: Another subtraction game

17.1 Subtraction games

Starting with a given positive integer N , two players alternately subtract a positive amount less than a given positive number $d < N$. The one who gets down to 0 wins.

Theorem 17.1. *The player who secures a multiple of d has a winning strategy.*

An equivalent version: the battle of numbers

Starting with 0, two players alternately add positive integers less than a given limit d . The one who gets to a specified N wins.

The winning positions are the terms of the arithmetic progression of common difference d containing N . Specifically, the small number $\text{mod } (N, d)$ is a winning position. Therefore, the first player has a winning strategy if and only if N is not divisible by d .

17.1.1 The Sprague-Grundy sequence

Let \mathcal{G} be a 2-person counter game in which two players alternately remove a positive amount of counters according to certain specified rules. The Sprague-Grundy sequence of \mathcal{G} is the sequence $(g(n))$ of nonnegative integers defined recursively as follows.

(1) $g(n) = 0$ for all n which have no legal move to another number. In particular, $g(0) = 0$.

(2) Suppose from position n it is possible to move to any of positions m_1, m_2, \dots, m_k , (all $< n$), then $g(n)$ is the smallest nonnegative integer different from $g(m_1), g(m_2), \dots, g(m_k)$.

Theorem 17.2. *The player who secures a position n with $g(n) = 0$ has a winning strategy.*

Example 1: the trivial counter game

If \mathcal{G} is the game which the players may subtract any *positive* amount, the Sprague-Grundy sequence is the natural sequence

$$0, 1, 2, 3, \dots, n, \dots$$

Example 2: removing not more than d counters

If \mathcal{G} is the game which subtracts numbers $< d$, then the Sprague-Grundy sequence is periodic $\overline{0, 1, 2, \dots, d-1}$. The values of n for which $g(n) = 0$ are precisely the multiples of d .

17.1.2 Subtraction of square numbers

Two players alternately subtract a positive square number. We calculate the Sprague-Grundy sequence.

$$\begin{aligned}
 g(0) &= 0 \\
 1 \rightarrow 0 &\implies g(1) = 1 \\
 g(2) &= 0 \\
 3 \rightarrow 2 &\implies g(3) = 1 \\
 4 \rightarrow 3, 0 &\implies g(4) = 2 \\
 5 \rightarrow 4, 1 &\implies g(5) = 0 \\
 6 \rightarrow 5, 2 &\implies g(6) = 1 \\
 7 \rightarrow 6, 3 &\implies g(7) = 0 \\
 8 \rightarrow 7, 4 &\implies g(8) = 1 \\
 9 \rightarrow 8, 5, 0 &\implies g(9) = 2 \\
 10 \rightarrow 9, 6, 1 &\implies g(10) = 0
 \end{aligned}$$

The values of $n \leq 1000$ for which $g(n) = 0$ are as follows: ¹

Suppose we start with 74. Player A can subtract 64 to get 10, which has value 0. This means no matter how B moves, A can always win. This is clear if B moves to 9 or 1. But if B moves to 6, then A can move to 5 which again has value 0, since now B can only move to 4 or 1.

Exercise

How would you win if the starting number is 200? or 500?

¹[Smith, p.68] incorrectly asserts that this sequence is periodic, with period 5.

17.1.3 Subtraction of square numbers

The first 100 terms of the Sprague-Grundy sequence are

1	2	3	4	5	6	7	8	9	10
1	0	1	2	0	1	0	1	2	0
1	0	1	2	0	1	0	1	2	0
1	0	1	2	3	2	3	4	5	3
2	3	4	0	1	2	3	2	0	1
2	3	2	0	1	2	3	2	3	4
5	0	1	3	4	5	0	1	3	4
5	0	1	3	0	1	0	1	2	4
3	0	1	5	6	2	3	4	5	6
2	3	4	5	0	1	6	3	2	4
2	6	4	5	0	1	6	4	2	4

The winning positions within 500 are as follows.

0	2	5	7	10	12	15	17	20	22	34	39	44	52	57
62	65	67	72	85	95	109	119	124	127	130	132	137	142	147
150	170	177	180	182	187	192	197	204	210	215	238	243	249	255
257	260	262	267	272	275	312	317	322	327	332	335	340	345	350
369	377	390	392	397	425	430	437	442	447	449	464			

Subtraction of aliquot parts

Two players start with a positive integer and alternately subtract any aliquot part (divisor) with the exception of the number itself from the number left by the opponent. Winner is the last player able to perform such a subtraction.

By way of example, if the original number is 12, first player may subtract either 1, 2, 3, 4, or 6 (but not 12). If he subtract 2, leaving 10, second player may subtract either 1, 2, or 5.

The first 100 terms of the Sprague-Grundy sequence are

1	2	3	4	5	6	7	8	9	10
0	1	0	2	0	1	0	3	0	1
0	2	0	1	0	4	0	1	0	2
0	1	0	3	0	1	0	2	0	1
0	5	0	1	0	2	0	1	0	3
0	1	0	2	0	1	0	4	0	1
0	2	0	1	0	3	0	1	0	2
0	1	0	6	0	1	0	2	0	1
0	3	0	1	0	2	0	1	0	4
0	1	0	2	0	1	0	3	0	1
0	2	0	1	0	5	0	1	0	2

The winning positions within 500 are as follows.

0	1	3	5	7	9	11	13	15	17	19	21	23	25	27
29	31	33	35	37	39	41	43	45	47	49	51	53	55	57
59	61	63	65	67	69	71	73	75	77	79	81	83	85	87
89	91	93	95	97	99	101	103	105	107	109	111	113	115	117
119	121	123	125	127	129	131	133	135	137	139	141	143	145	147
149	151	153	155	157	159	161	163	165	167	169	171	173	175	177
179	181	183	185	187	189	191	193	195	197	199	201	203	205	207
209	211	213	215	217	219	221	223	225	227	229	231	233	235	237
239	241	243	245	247	249	251	253	255	257	259	261	263	265	267
269	271	273	275	277	279	281	283	285	287	289	291	293	295	297
299	301	303	305	307	309	311	313	315	317	319	321	323	325	327
329	331	333	335	337	339	341	343	345	347	349	351	353	355	357
359	361	363	365	367	369	371	373	375	377	379	381	383	385	387
389	391	393	395	397	399	401	403	405	407	409	411	413	415	417
419	421	423	425	427	429	431	433	435	437	439	441	443	445	447
449	451	453	455	457	459	461	463	465	467	469	471	473	475	477
479	481	483	485	487	489	491	493	495	497	499				

Subtraction of proper divisors

The rules are the same with the exception that only *proper* divisors may be subtracted. Consider 1 an improper divisor.

The first 100 terms of the Sprague-Grundy sequence are

1	2	3	4	5	6	7	8	9	10
0	0	0	1	0	2	0	0	0	1
0	3	0	1	0	2	0	1	0	3
0	1	0	4	0	1	0	2	0	1
0	0	0	1	0	2	0	1	0	4
0	1	0	2	0	1	0	3	0	1
0	2	0	1	0	4	0	1	0	2
0	1	0	5	0	1	0	2	0	1
0	4	0	1	0	2	0	1	0	3
0	1	0	2	0	1	0	4	0	1
0	2	0	1	0	6	0	1	0	2

The winning positions within 500 are as follows.

0	1	2	3	5	7	8	9	11	13	15	17	19	21	23
25	27	29	31	32	33	35	37	39	41	43	45	47	49	51
53	55	57	59	61	63	65	67	69	71	73	75	77	79	81
83	85	87	89	91	93	95	97	99	101	103	105	107	109	111
113	115	117	119	121	123	125	127	128	129	131	133	135	137	139
141	143	145	147	149	151	153	155	157	159	161	163	165	167	169
171	173	175	177	179	181	183	185	187	189	191	193	195	197	199
201	203	205	207	209	211	213	215	217	219	221	223	225	227	229
231	233	235	237	239	241	243	245	247	249	251	253	255	257	259
261	263	265	267	269	271	273	275	277	279	281	283	285	287	289
291	293	295	297	299	301	303	305	307	309	311	313	315	317	319
321	323	325	327	329	331	333	335	337	339	341	343	345	347	349
351	353	355	357	359	361	363	365	367	369	371	373	375	377	379
381	383	385	387	389	391	393	395	397	399	401	403	405	407	409
411	413	415	417	419	421	423	425	427	429	431	433	435	437	439
441	443	445	447	449	451	453	455	457	459	461	463	465	467	469
471	473	475	477	479	481	483	485	487	489	491	493	495	497	499

Subtraction of primes

The first 100 terms of the Sprague-Grundy sequence

1	2	3	4	5	6	7	8	9	10
0	0	1	1	2	2	3	3	4	0
0	1	1	2	2	3	3	4	4	5
5	6	6	7	7	0	4	1	5	2
6	3	4	7	0	0	1	1	2	2
3	3	4	8	5	7	6	8	9	0
4	1	5	2	6	0	4	1	5	2
6	3	4	7	5	8	4	10	5	7
6	8	4	7	5	8	6	10	9	7
4	8	5	10	6	0	4	1	5	2
6	0	4	1	5	2	6	3	4	7

The winning positions within 500 are as follows.

0	1	2	10	11	26	35	36	50	56	86	92	101	116	122
126	134	146	156	170	176	188	196	206	218	236	248	254	260	266
290	296	302	310	311	320	326	336	344	356	362	376	386	392	396
404	416	426	446	452	470	476	482	486	494					

17.2 The nim sum of natural numbers

The nim sum of two nonnegative integers is the addition in their base 2 notations **without carries**. If we write

$$0 \boxplus 0 = 0, \quad 0 \boxplus 1 = 1 \boxplus 0 = 1, \quad 1 \boxplus 1 = 0,$$

then in terms of the base 2 expansions of a and b ,

$$a \boxplus b = (a_1 a_2 \cdots a_n) \boxplus (b_1 b_2 \cdots b_n) = (a_1 \boxplus b_1)(a_2 \boxplus b_2) \cdots (a_n \boxplus b_n).$$

The nim sum is associative, commutative, and has 0 as identity element. In particular, $a \boxplus a = 0$ for every natural number a .

Here are the nim sums of numbers ≤ 15 :

\boxplus	0	1	2	3	4	5	6	7	8	9	10	11	12	13	14	15
0	0	1	2	3	4	5	6	7	8	9	10	11	12	13	14	15
1	1	0	3	2	5	4	7	6	9	8	11	10	13	12	15	14
2	2	3	0	1	6	7	4	5	10	11	8	9	14	15	12	13
3	3	2	1	0	7	6	5	4	11	10	9	8	15	14	13	12
4	4	5	6	7	0	1	2	3	12	13	14	15	8	9	10	11
5	5	4	7	6	1	0	3	2	13	12	15	14	9	8	11	10
6	6	7	4	5	2	3	0	1	14	15	12	13	10	11	8	9
7	7	6	5	4	3	2	1	0	15	14	13	12	11	10	9	8
8	8	9	10	11	12	13	14	15	0	1	2	3	4	5	6	7
9	9	8	11	10	13	12	15	14	1	0	3	2	5	4	7	6
10	10	11	8	9	14	15	12	13	2	3	0	1	6	7	4	5
11	11	10	9	8	15	14	13	12	3	2	1	0	7	6	5	4
12	12	13	14	15	8	9	10	11	4	5	6	7	0	1	2	3
13	13	12	15	14	9	8	11	10	5	4	7	6	1	0	3	2
14	14	15	12	13	10	11	8	9	6	7	4	5	2	3	0	1
15	15	14	13	12	11	10	9	8	7	6	5	4	3	2	1	0

Theorem 17.3. *Suppose two players alternately play one of the counter games $\mathcal{G}_1, \dots, \mathcal{G}_k$ which have Sprague-Grundy sequences $(g_1(n)), \dots, (g_k(n))$ respectively. The player who secures a position (n_1, n_2, \dots, n_k) with*

$$g_1(n_1) \boxplus g_2(n_2) \boxplus \cdots \boxplus g_k(n_k) = 0$$

has a winning strategy.

17.3 The game *Nim*

Given three piles of marbles, with a , b , c marbles respectively, players A and B alternately remove a positive amount of marbles from any pile. The player who makes the last move wins.

Theorem 17.4. *In the game nim, the player who can balance the nim sum equation has a winning strategy.*

Therefore, provided that the initial position (a, b, c) does not satisfy $a \boxplus b \boxplus c = 0$, the first player has a winning strategy. For example, suppose the initial position is $(12, 7, 9)$. Since $12 \boxplus 9 = 5$, the first player can remove 2 marbles from the second pile to maintain a balance of the nim sum equation,

$$12 \boxplus 5 \boxplus 9 = 0$$

thereby securing a winning position.

This theorem indeed generalizes to an arbitrary number of piles.

17.4 Northcott's variation of Nim

Two players alternately move their counters on one of the rows, the only restriction being not moving onto or beyond the opponent's counter. The one who cannot move loses.

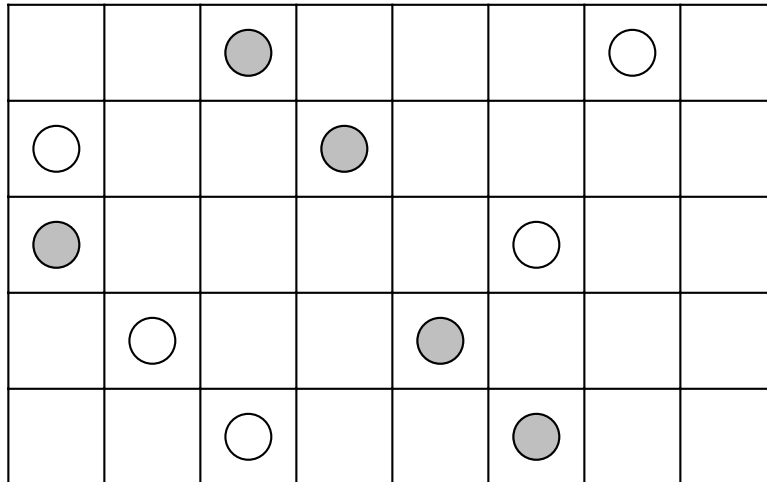

This is equivalent to nim if one considers a number of piles of counters corresponding to the number of spaces between the counters on the rows. (If a player tries to increase the number of spaces, the other player can force the same distance by pursuing the same number of spaces). Therefore the player who can balance the nim sum equation has a winning strategy.

For example, in the above arrangement, the numbers of spaces have nim sum

$$3 \boxplus 2 \boxplus 4 \boxplus 2 \boxplus 2 = 5.$$

It can be made 0 by moving 3 spaces in row 3.

17.5 Wythoff's game

Wythoff's game is a variant of Nim. Given two piles of marbles, a player either removes an arbitrary positive amount of marbles from any one pile, or an equal (positive) amount of marbles from both piles. The player who makes the last move wins.

We describe the position of the game by the amounts of marbles in the two piles.

If you can make $(2, 1)$, then you will surely win no matter how your opponent moves. Now, to forbid your opponent to get to this position, you should occupy $(3, 5)$.

The sequence of winning positions: starting with $(a_1, b_1) = (1, 2)$, construct (a_k, b_k) by setting

$$a_k := \min\{c : c > a_i, b_i, i < k\},$$

$$b_k := a_k + k.$$

Here are the 18 smallest winning positions for Wythoff's game:

1	3	4	6	8	9	11	12	14	16	17	19	21	22	24	25	27	29
2	5	7	10	13	15	18	20	23	26	28	31	34	36	39	41	44	47

Theorem 17.5. *The winning positions of Wythoff's game are the pairs $(\lfloor n\varphi \rfloor, \lfloor n\varphi^2 \rfloor)$, where $\varphi = \frac{\sqrt{5}+1}{2}$ is the golden ratio.*

Appendix: Beatty's Theorem

If α and β are positive irrational numbers satisfying $\frac{1}{\alpha} + \frac{1}{\beta} = 1$, then the sequences

$$\lfloor \alpha \rfloor, \lfloor 2\alpha \rfloor, \lfloor 3\alpha \rfloor, \dots$$

and

$$\lfloor \beta \rfloor, \lfloor 2\beta \rfloor, \lfloor 3\beta \rfloor, \dots$$

form a partition of the sequence of positive integers.

See Russian problem book, MG Problem 1300, solution, 62 (1989) 203.

If r and s are positive integers and $n = r + s$, then the union of the two sequences

$$\left\lfloor \frac{n}{r} \right\rfloor, \left\lfloor \frac{2n}{r} \right\rfloor, \dots, \left\lfloor \frac{(r-1)n}{r} \right\rfloor,$$

and

$$\left\lfloor \frac{n}{s} \right\rfloor, \left\lfloor \frac{2n}{s} \right\rfloor, \dots, \left\lfloor \frac{(s-1)n}{s} \right\rfloor.$$

is the natural sequence $1, 2, \dots, n-2$ if and only if r and s are relatively prime.

Exercise

1. What are the winning positions in the battle of numbers with $N = 100$ and $d = 7$?
2. The golden ratio φ has the property that φ^2 and φ have exactly the same digits after the decimal point. Find all numbers θ which have exactly the same digits as θ^2 after the decimal point.
3. A announces a two digit number from 01 to 99. B reverses the digits of this number and adds to it the sum of its digits and then announces his result. A continues in the same pattern. All numbers are reduced modulo 100, so that only two digit numbers are announced. What choices has A for the initial number in order to insure that B will at some time announce 00 ? ²

Project: Another subtraction game

Starting with a given positive integer, two players alternately subtract numbers not more than the predecessor used. The one who gets down to zero is the winner. Under what condition does the first player have a winning strategy?

Chapter 18

Repunits

- 1 k -right-transposable integers
 - 2 k -left-transposable integers
 - 3 Sam Yates' repunit riddles
 - 4 Recurring decimals
 - 5 The period length of a prime
- Appendix: Factorizations of repunits $R_n, n \leq 50$
- Appendix: Primitive divisors of repunits
- Appendix: Multiplicative digital root
- Exercise
- Project: Period lengths of primes < 100 .
- Project: A number whose cube root divides all numbers obtained by cyclic permutations of its digits.

18.1 k -right-transposable integers

Let k be a given positive integer. A positive integer X is k -transposable if in moving the leftmost digit to the rightmost, the number is multiplied by k .

Note that X is a repdigit if and only if $k = 1$. We shall assume $k > 1$. Suppose the number X has n digits, with leftmost digit a . We have

$$10(X - a \cdot 10^{n-1}) + a = kX.$$

From this, $(10 - k)X = a(10^n - 1) = 9a \cdot R_n$.

If $k \neq 3$, $10 - k$ can only have prime divisors 2, 3, 5. The equation will reduce to $X = a$ repdigit, which is clearly impossible.

For $k = 3$, we have $7X = a(10^n - 1)$. If $a = 7$, then again X is a repdigit. Therefore, we must have 7 dividing $10^n - 1$. This is possible only if n is a multiple of 6. Therefore $X = a \cdot \frac{10^{6m} - 1}{7}$ and has first digit a .

Now,

$$\frac{10^{6m} - 1}{7} = (142857)_m.$$

It is easy to see that a can only be 1 or 2.

Therefore, the only k -transposable numbers are $(142857)_m$ and $(285714)_m$ with $k = 3$.

18.2 k -left-transposable integers

Let k be a given positive integer. A positive integer X is k -left-transposable if in moving the rightmost digit to the leftmost, the number is multiplied by k . Note that X is a repdigit if and only if $k = 1$. We shall assume $k > 1$. Suppose the number X has n digits, and its rightmost digit is b . We have

$$b \cdot 10^{n-1} + \frac{X - b}{10} = kX.$$

From this, $b \cdot 10^n + X - b = 10kX$, and

$$(10k - 1)X = b(10^n - 1).$$

Since X has n digits, $b(10^n - 1) > (10k - 1)10^{n-1}$, and $b > \frac{10^{n-1}(10k-1)}{10^n-1} = k - \frac{1}{10}$. This shows that $b \geq k$.

k		n
2	$19X = b(10^n - 1)$	$18m$
3	$29X = b(10^n - 1)$	$28m$
4	$39X = b(10^n - 1)$	$12m$
5	$49X = b(10^n - 1)$	$42m$
6	$59X = b(10^n - 1)$	$58m$
7	$69X = b(10^n - 1)$	$22m$
8	$79X = b(10^n - 1)$	$13m$
9	$89X = b(10^n - 1)$	$44m$

These lead to the following numbers:

$$X_2 = 105263157894736842,$$

$$X_3 = 1034482758620689655172413793,$$

$$X_4 = 102564102564,$$

$$X_5 = 102040816326530612244897959183673469387755,$$

$$X_6 = 1016949152542372881355932203389830508474576271186440677966,$$

$$X_7 = 1014492753623188405797,$$

$$X_8 = 1012658227848,$$

$$X_9 = 10112359550561797752808988764044943820224719.$$

Each of these X_k can be replaced by $\frac{b}{k} \cdot X_k$ for $k = b, \dots, 9$. Every k -left-transposable number is of the form $(X_k)_m$ for X_k given above and $m \geq 1$.

18.3 Sam Yates' repunit riddles

1. What digits should be substituted for the letters so that the sum of the nine identical addends will be a repunit? ¹

$$\begin{array}{r}
 R E P U N I T S \\
 R E P U N I T S \\
 R E P U N I T S \\
 R E P U N I T S \\
 R E P U N I T S \\
 R E P U N I T S \\
 R E P U N I T S \\
 R E P U N I T S \\
 R E P U N I T S \\
 + R E P U N I T S \\
 \hline
 \end{array}$$

2. Are two repunits with consecutive even numbers as their subscripts relatively prime? ²
3. Are two repunits with consecutive numbers as their subscripts relatively prime? ³
4. Are two repunits with consecutive odd numbers as their subscripts relatively prime? ⁴
5. Aside from 3, what prime p divides R_p ? ⁵
6. What digit does each letter of this multiplication represent? ⁶

$$\begin{array}{r}
 R R R R R R R \\
 \times R R R R R R R \\
 \hline
 R E P U N I T I N U P E R
 \end{array}$$

7. An old car dealer's record in the 1960's shows that the total receipts for the sale of new cars in one year came to 1,111,111.00 dollars. If each car had eight cylinders and was sold for the same price as each other car, how many cars did he sell?

¹REPUNITS=12345679 and the sum is R_9 .

²No. Repunits with even subscripts are divisible by 11.

³Yes. Consecutive numbers are relatively prime, and $\gcd(R_m, R_n) = R_{\gcd(m,n)}$.

⁴Yes. Consecutive odd numbers are relatively prime.

⁵3 and 5.

⁶ $R_7 \times R_7 = R_{13}$.

8. Find a pair of repunits whose product is a 100-digit palindrome.⁷
9. If a Mersenne number $M_p = 2^p - 1$ is prime, is the corresponding repunit R_p also prime?⁸
10. What is the smallest repunit divisible by the square of 11? What is the smallest repunit divisible by the square of R_{11} ?

In general, the smallest repunit divisible by the square of R_n is R_N , where $N = nR_n$.

⁷If $R_p \cdot R_q$ has 100 digits, $p + q = 101$. Suppose $p \leq q$ and $p = 9k + m$ for $1 \leq m \leq 9$. Since the product is a palindrome, it cannot contain **A** and **B**. We must have $k = 0$ and $p \leq 9$. For any $p = 2, \dots, 9$, the product $R_p \cdot R_q$ is the palindrome $\overline{\mathbf{P}}_{102-2p}1$, where

$$\overline{\mathbf{P}} = \begin{cases} 12_k & \text{if } p = 2, \\ 12 \cdots (p-1)(p-1)32 & \text{if } 3 \leq p \leq 9. \end{cases}$$

⁸ $M_3 = 2^3 - 1 = 7$ is prime but $R_3 = 111 = 3 \times 37$.

18.4 Recurring decimals

The decimal expansion of a rational number is eventually periodic. It is finite if and only if the denominator has no prime divisors other than 2 and 5.

The decimal expansion of $\frac{1}{n}$ is *purely* periodic if and only if n is a prime. For $p = 3$, this is the most well known recurring decimal

$$\frac{1}{3} = 0.333 \dots = 0.\overline{3}.$$

with period length 1. Here are the periods of the reciprocals of the first few primes, together with their period lengths.

p	period	$\lambda(p)$
3	3	1
7	142857	6
11	09	2
13	076923	6
17	0588235294117647	16
19	052631578947368421	18
23	0434782608695652173913	22
29	0344827586206896551724137931	28
31	032258064516129	15
37	027	3
41	0243902439	10
43	023255813953488372093	21
47	0212765957446808510638297872340425531914893617	46

18.5 The period length of a prime

The period length of a prime number p means the length of the shortest repeating block of digits in the decimal expansion of $\frac{1}{p}$.

Suppose $\frac{1}{p}$ has period length λ :

$$\frac{1}{p} = 0.\overline{a_1 \cdots a_\lambda}.$$

Then moving the decimal places n places to the right, we have

$$\frac{10^\lambda}{p} = a_1 \cdots a_\lambda.\overline{a_1 \cdots a_\lambda},$$

and

$$\frac{10^\lambda}{p} - \frac{1}{p} = a_1 \cdots a_\lambda$$

is an integer. This means that p divides $10^\lambda - 1$. Clearly, p cannot be 2 or 5. It is known that if $p \neq 2, 5$, then $10^{p-1} - 1$ is divisible by p , and any number λ for which $10^\lambda - 1$ is divisible by p divides $p - 1$.

Theorem 18.1. *If $p \neq 2, 5$, the period length of p is the smallest divisor λ of $p - 1$ such that p divides $10^\lambda - 1$.*

Theorem 18.2. *Let $p > 5$ be a prime. The period length of p is the smallest divisor n of $p - 1$ such that p divides R_n .*

Proof. Note that $10^n - 1 = 9_n = 9 \times R_n$. If $p \neq 3$, then p divides R_n . \square

We say that p is a primitive prime divisor the repunit n . Thus, for a prime $p > 5$, the period length of p is the number n for which p is primitive prime divisor. A table of primitive prime divisors of repunits is given in an Appendix.

Appendix: Factorizations of repunits R_n for $n \leq 50$

n	R_n
2	11.
3	3×37 .
4	11×101 .
5	41×271 .
6	$3 \times 7 \times 11 \times 13 \times 37$.
7	239×4649 .
8	$11 \times 73 \times 101 \times 137$.
9	$3^2 \times 37 \times 333667$.
10	$11 \times 41 \times 271 \times 9091$.
11	21649×513239 .
12	$3 \times 7 \times 11 \times 13 \times 37 \times 101 \times 9901$.
13	$53 \times 79 \times 265371653$.
14	$11 \times 239 \times 4649 \times 909091$.
15	$3 \times 31 \times 37 \times 41 \times 271 \times 2906161$.
16	$11 \times 17 \times 73 \times 101 \times 137 \times 5882353$.
17	$2071723 \times 5363222357$.
18	$3^2 \times 7 \times 11 \times 13 \times 19 \times 37 \times 52579 \times 333667$.
19	<i>prime</i>
20	$11 \times 41 \times 101 \times 271 \times 3541 \times 9091 \times 27961$.
21	$3 \times 37 \times 43 \times 239 \times 1933 \times 4649 \times 10838689$.
22	$11^2 \times 23 \times 4093 \times 8779 \times 21649 \times 513239$.
23	<i>prime</i>
24	$3 \times 7 \times 11 \times 13 \times 37 \times 73 \times 101 \times 137 \times 9901 \times 99990001$.
25	$41 \times 271 \times 21401 \times 25601 \times 182521213001$.
26	$11 \times 53 \times 79 \times 859 \times 265371653 \times 1058313049$.
27	$3^3 \times 37 \times 757 \times 333667 \times 44033465477631$.
28	$11 \times 29 \times 101 \times 239 \times 281 \times 4649 \times 909091 \times 121499449$.
29	$3191 \times 16763 \times 43037 \times 62003 \times 77843839397$.
30	$3 \times 7 \times 11 \times 13 \times 31 \times 37 \times 41 \times 211 \times 241 \times 271 \times 2161 \times 9091 \times 2906161$.
31	$2791 \times 6943319 \times 57336415063790604359$.
32	$11 \times 17 \times 73 \times 101 \times 137 \times 353 \times 449 \times 641 \times 1409 \times 69857 \times 5882353$.
33	$3 \times 37 \times 67 \times 21649 \times 513239 \times 1344628210313298373$.
34	$11 \times 103 \times 4013 \times 2071723 \times 5363222357 \times 21993833369$.
35	$41 \times 71 \times 239 \times 271 \times 4649 \times 123551 \times 102598800232111471$.
36	$3^2 \times 7 \times 11 \times 13 \times 19 \times 37 \times 101 \times 9901 \times 52579 \times 333667 \times 999999000001$.
37	$2028119 \times 247629013 \times 2212394296770203368013$.
38	$11 \times 9090909090909091 \times R_{19}$.
39	$3 \times 37 \times 53 \times 79 \times 265371653 \times 9009009009009090909091$.
40	$11 \times 41 \times 73 \times 101 \times 137 \times 271 \times 3541 \times 9091 \times 27961 \times 1676321 \times 5964848081$.
41	$83 \times 1231 \times 538987 \times 201763709900322803748657942361$.
42	$3 \times 7^2 \times 11 \times 13 \times 37 \times 43 \times 127 \times 239 \times 1933 \times 2689 \times 4649 \times 459691 \times 909091 \times 10838689$.
43	$173 \times 1527791 \times 1963506722254397 \times 2140992015395526641$.
44	$11^2 \times 23 \times 89 \times 101 \times 4093 \times 8779 \times 21649 \times 513239 \times 1052788969 \times 1056689261$.
45	$3^2 \times 31 \times 37 \times 41 \times 271 \times 238681 \times 333667 \times 2906161 \times 4185502830133110721$.
46	$11 \times 47 \times 139 \times 2531 \times 549797184491917 \times R_{23}$.
47	$35121409 \times 316362908763458525001406154038726382279$.
48	$3 \times 7 \times 11 \times 13 \times 17 \times 37 \times 73 \times 101 \times 137 \times 9901 \times 5882353 \times 99990001 \times 9999999000000001$.
49	$239 \times 4649 \times 505885997 \times 1976730144598190963568023014679333$.
50	$11 \times 41 \times 251 \times 271 \times 5051 \times 9091 \times 21401 \times 25601 \times 182521213001 \times 78875943472201$.

Appendix: Primitive prime divisors of repunits

n	Primitive prime divisors of R_n
2	11.
3	3, 37.
4	101.
5	41, 271.
6	7, 13.
7	239, 4649.
8	73, 137.
9	333667.
10	9091.
11	21649, 513239.
12	9901.
13	53, 79, 265371653.
14	909091.
15	31, 2906161.
16	17, 5882353.
17	2071723, 5363222357.
18	19, 52579.
19	11111111111111111111.
20	3541, 27961.
21	43, 1933, 10838689.
22	23, 4093, 8779.
23	11111111111111111111.
24	99990001.
25	21401, 25601, 182521213001.
26	859, 1058313049.
27	757, 440334654777631.
28	29, 281, 121499449.
29	3191, 16763, 43037, 62003, 77843839397.
30	211, 241, 2161.
31	2791, 6943319, 57336415063790604359.
32	353, 449, 641, 1409, 69857.
33	67, 1344628210313298373.
34	103, 4013, 21993833369.
35	71, 123551, 102598800232111471.
36	999999000001.
37	2028119, 247629013, 2212394296770203368013.
38	909090909090909091.
39	9009009009009090909091.
40	1676321, 5964848081.
41	83, 1231, 538987, 201763709900322803748657942361.
42	127, 2689, 459691.
43	173, 1527791, 1963506722254397, 2140992015395526641.
44	89, 1052788969, 1056689261.
45	238681, 4185502830133110721.
46	47, 139, 2531, 549797184491917.
47	35121409, 316362908763458525001406154038726382279.
48	9999999000000001.
49	505885997, 1976730144598190963568023014679333.
50	251, 5051, 78875943472201.

Exercise

Find all prime numbers p for which $\frac{1}{p}$ has period length 11.⁹

⁹Problem 2207, *J. Recreational Math.*, 27 (1995) 59.

Appendix: The multiplicative digital root

The multiplicative digital root of a number is the single digit number obtained by iterating the digital product operation. Thus,

$$6244 \rightarrow 6 \cdot 2 \cdot 4 \cdot 4 = 192 \rightarrow 1 \cdot 9 \cdot 2 = 18 \rightarrow 1 \cdot 8 = 8.$$

Theorem 18.3 (Kuczma). *The multiplicative digital root of n is 1 if and only if n is a repunit.*

Proof. The digital product of a number is 1 if and only if it is a repunit. We claim that no number can have a repunit R_n , $n \geq 2$, for digital product. If so, this would mean that R_n factors into one digit numbers, and its prime divisors can only be 3 and 7. In other words, $R_n = 3^h \cdot 7^k$ for some integers $h, k \geq 0$.

The powers of 7 modulo 100 are 1, 7, 49, 43. Those of 3 modulo 100 are given in the first row of the table below. Their product cannot be 11 modulo 100.

1	3	9	27	81	43	29	87	61	83	49	47	41	23	69	7	21	63	89	67
7	21	63	89	67	1	3	9	27	81	43	29	87	61	83	49	47	41	23	69
49	47	41	23	69	7	21	63	89	67	1	3	9	27	81	43	29	87	61	83
43	29	87	61	83	49	47	41	23	69	7	21	63	89	67	1	3	9	27	81

□

Exercise

1. What are the decimal expansions of $\frac{1}{2^k}$, $\frac{1}{5^k}$, and $\frac{1}{2^h \cdot 5^k}$?
2. Calculate the period of $p = 67$.
3. If p is any odd prime, show that the decimal expansion of the fraction $\frac{1}{p}$ will repeat in $\frac{p-1}{2}$ digits or some factor thereof it and only if $p \equiv \pm 3^k \pmod{40}$.
4. What is the smallest integer of $2n$ identical digits which is the product of two n -digit numbers?

Clearly $n \geq 2$. Since $1111 = 11 \times 101$, we seek 6 digit numbers. Now,

$$R_6 = 3 \times 7 \times 11 \times 13 \times 37.$$

There are four ways of rearranging it as a product of two 3-digit numbers:

$$143 \times 777 = 231 \times 481 = 259 \times 429 = 273 \times 407.$$

5. Let N be an integer of p digits. If the last digit is removed and placed before the remaining $p-1$ digits, a new number of p digits is formed which is $\frac{1}{n}$ th of the original number. Find the most general such number N .
6. (a) Find the smallest integer N such that, if the units digits is transposed from right to left, a number M is obtained where $M = 5N$.¹⁰
7. A certain 3-digit number yields a quotient of 26 when divided by the sum of its digits. If the digits are reversed, the quotient is 48. What is the smallest 3-digit number for which this is possible ?
8. Without the use of tables, find the smallest integer whose cube terminates in seven sevens.¹¹

¹¹ 9660753 = 90163951237274777777.
¹⁰ $N = 142857; M = 714285 = 5N$.

Project: Period lengths of primes < 100

Find the period lengths of the primes < 100 by using the factorization of repunits given above. Note that 59, 61, and 97 are the only primes < 100 that cannot be found in the table above.

Prime	Period lengths		Prime	Period lengths
7			11	
13			17	
19			23	
29			31	
37			41	
43			47	
53			59	
61			67	
71			73	
79			83	
89			97	

Project

It is known that the number

$$N = 19000458461599776807277716631$$

is a perfect cube. Find its cube root M . Verify that $N = N_0$ the twenty-eight numbers N_i , $1 \leq i \leq 28$ which are formed by cyclic permutations of its digits are all divisible by the cube root of N .

i	N_i	$N_i \div M$
0	19000458461599776807277716631	
1	90004584615997768072777166311	
2	45846159977680727771663119	
3	458461599776807277716631190	
4	4584615997768072777166311900	
5	45846159977680727771663119000	
6	58461599776807277716631190004	
7	84615997768072777166311900045	
8	46159977680727771663119000458	
9	61599776807277716631190004584	
10	15997768072777166311900045846	
11	59977680727771663119000458461	
12	99776807277716631190004584615	
13	97768072777166311900045846159	
14	77680727771663119000458461599	
15	76807277716631190004584615997	
16	68072777166311900045846159977	
17	80727771663119000458461599776	
18	7277716631190004584615997768	
19	72777166311900045846159977680	
20	27771663119000458461599776807	
21	77716631190004584615997768072	
22	77166311900045846159977680727	
23	71663119000458461599776807277	
24	16631190004584615997768072777	
25	66311900045846159977680727771	
26	63119000458461599776807277716	
27	31190004584615997768072777166	
28	11900045846159977680727771663	

Chapter 19

More digital trivia

1. Larry, Curly, and Moe had an unusual combination of ages. The sum of any two of the three ages was the reverse of the third age (e.g., $16 + 52 = 68$, the reverse of 86). All were under 100 years old.
 - (a) What was the sum of the ages?
 - (b) If Larry was older than either of the others, what was the youngest he could be?
2. Let n be a nonnegative integer. The number formed by placing 2^n and 2^{n+1} side by side in any order is divisible by 3. ¹
3. Find positive integers x, y, z (less than 100), such that $x^2 + y^2 = z^2$ and $X^2 + Y^2 = Z^2$ where X, Y, Z are derived from x, y, z by inserting an extra digit (the same for all) on the left.
4. (a) Find the smallest positive integer N having the property that the sum of its digits does not divide the sum of the cubes of its digits.
(b) Find the two consecutive positive integers each of which equals the sum of the cubes of its digits. ²
5. Find two perfect cubes which, considered jointly, contain the digits 0, 1, 2, 3, 4, 5, 6, 7, 8 and 9 each once. Is the solution unique? ³
6. Show that there is but one five-digit integer whose last three digits are alike and whose square contains no duplicate digits. ⁴

¹ Suppose 2^n has k digits. Putting 2^{n+1} on the left hand side of 2^n gives the number $2^{n+1} \cdot 10^k + 2^n$. Modulo 3, this is $(-1)^{n+1} + (-1)^n \equiv 0$.

² 173 and 073; (a) $N = 112$; (b) $N = 11$

³ Unique solution: 253 and 833 and 126 = 312

⁴ 81222 = 6597013284

7. Determine the largest and smallest perfect squares which can be written with the ten digits 0, 1, 2, 3, 4, 5, 6, 7, 8, 9, used once each in both cases.
8. Find two perfect squares, of five digits each, which together contain all the digits 0, 1, 2, 3, 4, 5, 6, 7, 8, 9. How many solutions are there ?
9. Let $k \geq 3$. Determine all numbers of the form $1^k + 2^k + \dots + n^k$ whose decimal expansions consist of the ten digits 0, 1, 2, 3, 4, 5, 6, 7, 8, and 9 without repetition.
10. Determine all binomial coefficients whose decimal expansions consist of the ten digits 0, 1, 2, 3, 4, 5, 6, 7, 8, and 9 without repetition.⁵
11. Find a number whose cube and fourth power together contain the ten digits, once each. (See E116 and Problem following E602).⁶
12. Find a multiple of 7 whose square has eight digits of the form $ababbcc$.⁷
13. What is the largest prime whose square contains no duplicate digits ?⁸
14. Find a four-digit square which remains a square when two zeros are intercalated between the thousands digit and the hundreds digit.⁹
15. Find a number and its fourth power, which together have nine digits, all different.¹⁰
16. Find a perfect square whose digits form one of the permutations of five consecutive digits. (See also E538, 578).¹¹
17. Find a perfect square of 7 digits with all digits even and positive.¹²

⁵ $\binom{595}{4} = 5169738420$ and $\binom{253}{5} = 8301429675$.
 In fact, 2, 18 and 69 are the only numbers with two distinct powers which together contain the ten digits, once each.
⁶ $21397^2 = 457831609$,
 $52^2 = 2704$, $200704 = 448^2$ and $87^2 = 7569$, $700569 = 837^2$.
⁷ $n = 32$, and $n^4 = 1048576$.
⁸ $152^2 = 23104$ and $179^2 = 32041$.
⁹ $1692^2 = 2862864$, $2878^2 = 8282884$, $2978^2 = 8868484$.
¹⁰ $21397^2 = 457831609$,
 $52^2 = 2704$, $200704 = 448^2$ and $87^2 = 7569$, $700569 = 837^2$.
¹¹ $n = 32$, and $n^4 = 1048576$.
¹² $152^2 = 23104$ and $179^2 = 32041$.

18. Find a number of the form $ab0cd$ whose square contains the nine digits 1, 2, 3, 4, 5, 6, 7, 8, 9. ¹³
19. Find a perfect cube whose digits form a permutation of consecutive digits. (See also E538). ¹⁴
20. Find a square of ten digits such that the two numbers formed by the first five and last five digits are consecutive. ¹⁵
21. Find the smallest four-digit number such that the sum of products of pairs of digits is equal to the sum of products of sets of three.
22. Find three three-digit numbers in geometrical progression which can be derived from one another by cyclic permutation of digits. (See also E714).

The squares: 326597184, 361874529, 529874361, 576432081, 627953481, 842973156. ¹³

The only higher powers satisfying the same condition are the fifth powers of 32 and 243. ¹⁴

$36365^2 = 1322413225$; $63636^2 = 4049540496$. ¹⁵

Chapter 20

The shoemaker's knife

- 1 Archimedes' twin circles
- 2 Incircle of the shoemaker's knife
 - Archimedes' construction
 - Bankoff's constructions
 - Woo's constructions
- 3 More Archimedean circles
 - Exercise

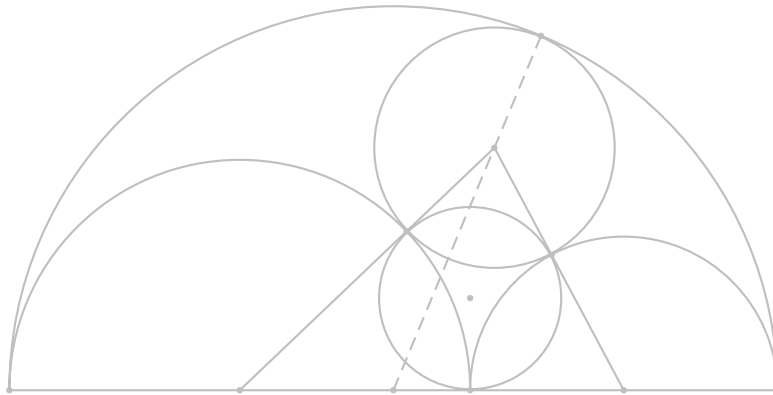

20.1 Archimedes' twin circles

Let P be a point on a segment AB . The region bounded by the three semicircles (on the same side of AB) with diameters AB , AP and PB is called a shoemaker's knife. Suppose the smaller semicircles have radii a and b respectively. Let Q be the intersection of the largest semicircle with the perpendicular through P to AB . This perpendicular is an internal common tangent of the smaller semicircles.

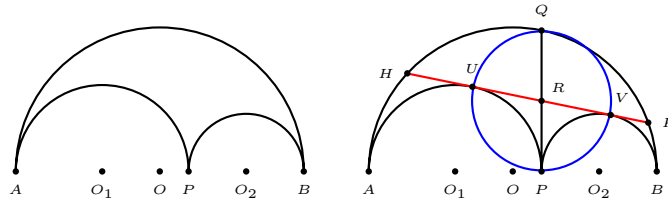

Theorem 20.1 (Archimedes). *The two circles each tangent to CP , the largest semicircle AB and one of the smaller semicircles have equal radii t , given by*

$$t = \frac{ab}{a+b}.$$

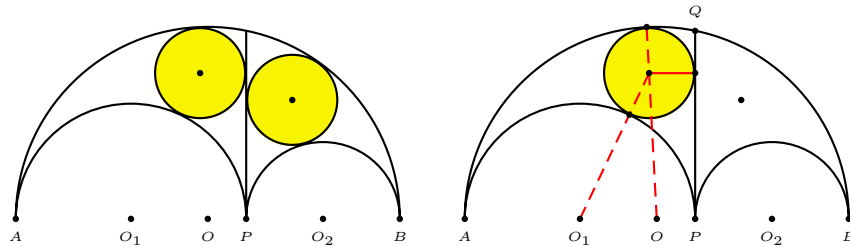

20.2.2 Bankoff's constructions

Theorem 20.3 (Leon Bankoff). *If the incircle $C(\rho)$ of the shoemaker's knife touches the smaller semicircles at X and Y , then the circle through the points P, X, Y has the same radius as the Archimedean circles.*

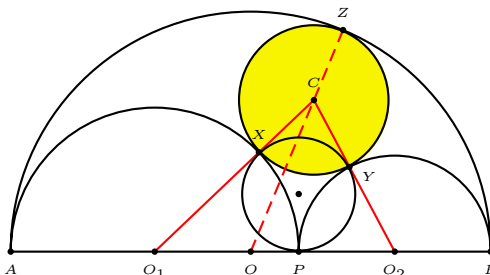

Proof. The circle through P, X, Y is clearly the incircle of the triangle CO_1O_2 , since

$$CX = CY = \rho, \quad O_1X = O_1P = a, \quad O_2Y = O_2P = b.$$

The semiperimeter of the triangle CO_1O_2 is

$$a + b + \rho = (a + b) + \frac{ab(a + b)}{a^2 + ab + b^2} = \frac{(a + b)^3}{a^2 + ab + b^2}.$$

The inradius of the triangle is given by

$$\sqrt{\frac{ab\rho}{a + b + \rho}} = \sqrt{\frac{ab \cdot ab(a + b)}{(a + b)^3}} = \frac{ab}{a + b}.$$

This is the same as t , the common radius of Archimedes' twin circles. \square

First construction

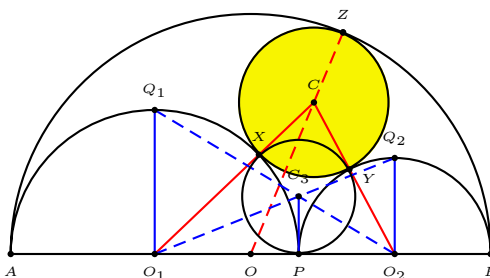

Second construction

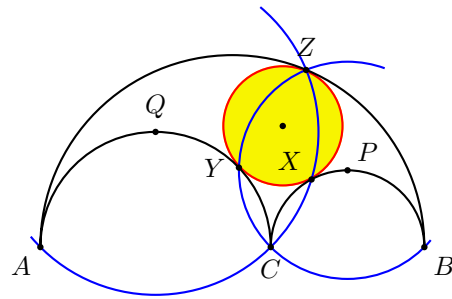

20.2.3 Woo's three constructions

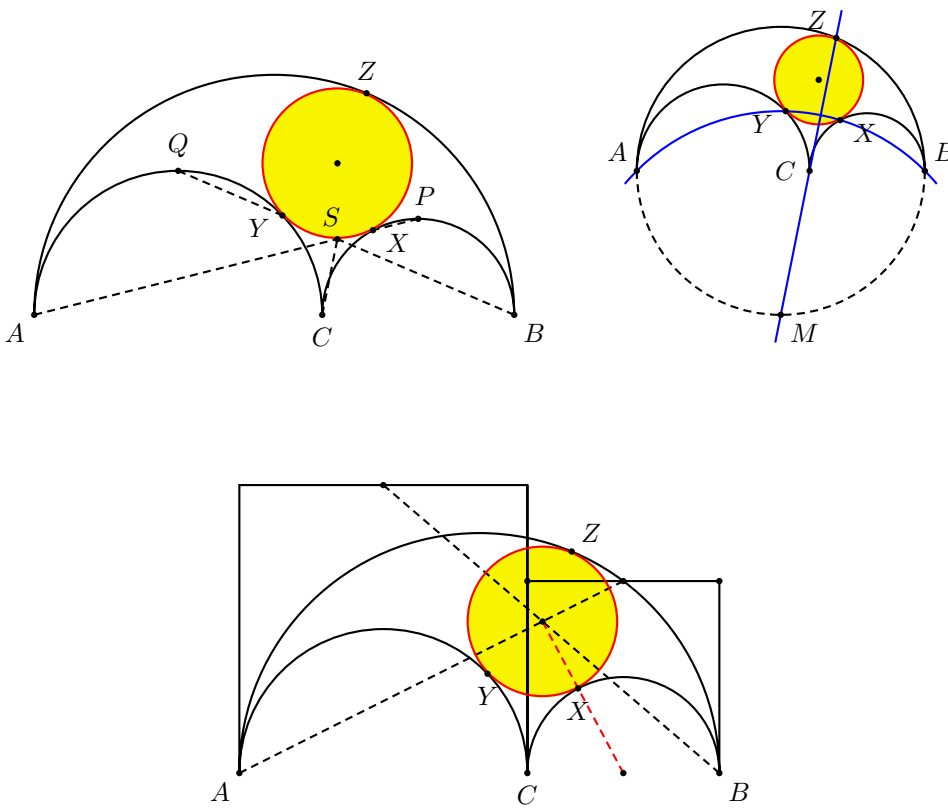

20.3 More Archimedean circles

Let UV be the external common tangent of the semicircles $O_1(a)$ and $O_2(b)$, which extends to a chord HK of the semicircle $O(a+b)$. Let C_4 be the intersection of O_1V and O_2U . Since

$$O_1U = a, \quad O_2V = b, \quad \text{and} \quad O_1P : PO_2 = a : b,$$

$C_4P = \frac{ab}{a+b} = t$. This means that the circle $C_4(t)$ passes through P and touches the common tangent HK of the semicircles at N .

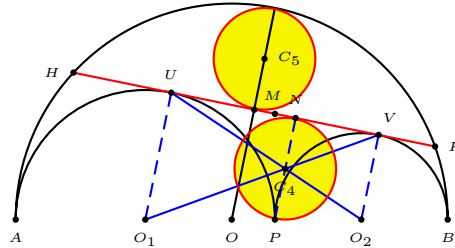

Let M be the midpoint of the chord HK . Since O and P are symmetric (isotomic conjugates) with respect to O_1O_2 ,

$$OM + PN = O_1U + O_2V = a + b.$$

it follows that $(a+b) - QM = PN = 2t$. From this, the circle tangent to HK and the minor arc HK of $O(a+b)$ has radius t . This circle touches the minor arc at the point Q .

Theorem 20.4 (Thomas Schoch). *The incircle of the curvilinear triangle bounded by the semicircle $O(a+b)$ and the circles $A(2a)$ and $B(2b)$ has radius $t = \frac{ab}{a+b}$.*

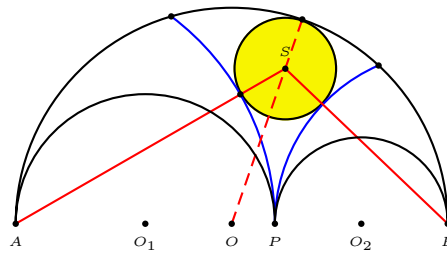

Proof. Denote this circle by $S(x)$. Note that SO is a median of the triangle SO_1O_2 . By Apollonius theorem,

$$(2a + x)^2 + (2b + x)^2 = 2[(a + b)^2 + (a + b - x)^2].$$

From this, $x = \frac{ab}{a+b} = t$. □

Exercise

1. The circles (C_1) and (C'_1) are each tangent to the outer semicircle of the shoemaker's knife, and to OQ_1 at Q_1 ; similarly for the circles (C_2) and (C'_2) . Show that they have equal radii $t = \frac{ab}{a+b}$.

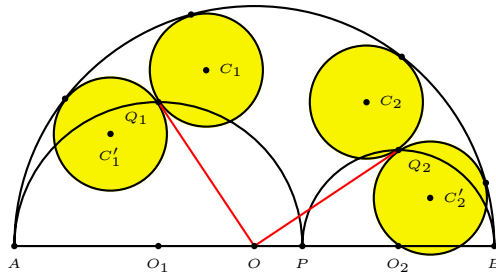

2. We call the semicircle with diameter O_1O_2 the *midway* semicircle of the shoemaker's knife.

Show that the circle tangent to the line PQ and with center at the intersection of (O_1) and the midway semicircle has radius $t = \frac{ab}{a+b}$.

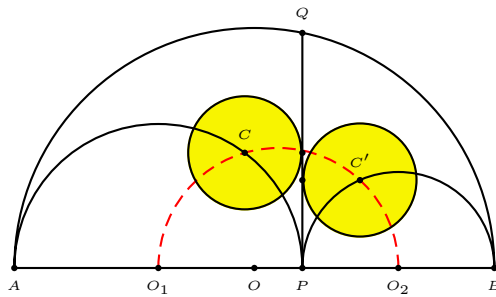

3. Show that the radius of the circle tangent to the midway semicircle, the outer semicircle, and with center on the line PQ has radius $t = \frac{ab}{a+b}$.

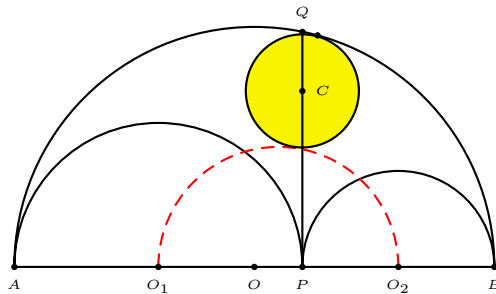

Chapter 21

Infinitude of prime numbers

- 1 Fibonacci and Fermat numbers
 - 2 Somos sequences
 - 3 Fürstenberg's topological proof made easy
- Appendix: Euclid's proof
Appendix: The prime numbers below 20,000
Exercise
Project: Prime links
Project: Truncatable primes

21.1 Proofs by construction of sequence of relatively prime numbers

Fibonacci numbers ¹

Since $\gcd(F_m, F_n) = F_{\gcd(m,n)}$, if there are only finitely many primes p_1, \dots, p_k , then the primes in F_{p_1}, \dots, F_{p_k} are distinct, and each one of them has only one prime divisor. This contradicts $F_{19} = 4181 = 37 \times 113$.

Fermat numbers

The Fermat numbers are $F_n := 2^{2^n} + 1$. It is well known that Fermat's conjecture of the primality of F_n is wrong. While

$$F_0 = 3, \quad F_1 = 5, \quad F_2 = 17, \quad F_3 = 257, \quad F_4 = 65537$$

are all primes, Euler found that

$$F_5 = 2^{32} + 1 = 4294967297 = 641 \times 6700417.$$

Note that

$$F_n - 2 = 2^{2^n} - 1 = (2^{2^{n-1}} + 1)(2^{2^{n-1}} - 1) = F_{n-1}(F_{n-1} - 2).$$

By induction,

$$F_n = F_{n-1}F_{n-2} \cdots F_1 \cdot F_0 + 2, \quad n \geq 1.$$

From this, we see that F_n does not contain any factor of F_0, F_1, \dots, F_{n-1} . Hence, the Fermat numbers are pairwise relatively prime. From this, it follows that there are infinitely primes.

¹M. Wunderlich, Another proof of the infinite primes theorem, *American Math. Monthly*, 72 (1965) 305.

21.2 Somos sequences

Define two sequences (a_n) and (b_n) with initial values

$$a_0 = a_1 = 1, \quad b_0 = 0, b_1 = 1,$$

and for $n \geq 2$ recursively by

$$\begin{aligned} a_n &= a_{n-2}b_{n-1}, \\ b_n &= a_{n-1} + a_n. \end{aligned}$$

Here are the first few terms

n	0	1	2	3	4	5	6	7	8	9	...
a_n	1	1	1	2	3	10	39	490	20631	10349290	...
b_n	0	1	2	3	5	13	49	529	21121	10369921	...

Theorem 21.1. *The terms of the sequence (b_n) , $n \geq 1$ are relatively prime.*

Proof. If we calculate the first few terms

$$\begin{aligned} a_2 &= a_0b_1 = b_1, \\ a_3 &= a_1b_2 = b_2, \\ a_4 &= a_2b_3 = b_1b_3, \\ a_5 &= a_3b_4 = b_2b_4, \\ a_6 &= a_4b_5 = b_1b_3b_5, \\ a_7 &= a_5b_6 = b_2b_4b_6, \\ &\vdots \end{aligned}$$

we see a pattern, namely,

$$\begin{aligned} a_{2n} &= b_1b_3 \cdots b_{2n-1}, \\ a_{2n+1} &= b_2b_4 \cdots b_{2n}. \end{aligned}$$

Suppose, inductively, that $b_1, b_2, \dots, b_{2n-1}$ are relatively prime. Then,

$$b_{2n} = a_{2n-1} + a_{2n} = b_2b_4 \cdots b_{2n-2} + b_1b_3 \cdots b_{2n-1}$$

does not contain any divisor of $b_1, b_2, \dots, b_{2n-1}$; nor does

$$b_{2n+1} = a_{2n} + a_{2n+1} = b_1b_3 \cdots b_{2n-1} + b_2b_4 \cdots b_{2n}$$

contain any divisor of b_1, b_2, \dots, b_{2n} . It follows by induction that no two of the terms $b_1, b_2, \dots, b_n, \dots$ contain a common divisor. □

21.3 Fürstenberg's topological proof made easy

There is a famous proof of the infinitude of primes using topology. It can be found in many books. Apart from an introductory sentence, here is the entire article of [Fürstenberg]:

We introduce a topology into the space of integers S , by using the arithmetic progressions (from $-\infty$ to $+\infty$) as a basis. It is not difficult to verify that this actually yields a topological space. In fact, under this topology, S may be shown to be normal and hence metrizable. Each arithmetic progression is closed as well as open, since its complement is the union of other arithmetic progressions (having the same difference). As a result, the union of any finite number of arithmetic progression is closed. Consider now the set $A = \bigcup A_p$, where A_p consists of all multiples of p , and p runs through the set of primes ≥ 2 . The only numbers not belonging to A are -1 and 1 , and since the set $\{-1, 1\}$ is clearly not an open set, A cannot be closed. Hence A is not a finite union of closed sets which proves that there are an infinity of primes.

The most recent issue of *Mathematics Magazine* ² contains a paraphrase of this proof, avoiding the language of topology.

Let \mathbb{Z} be the set of integers. We say that a subset $A \subset \mathbb{Z}$ is periodic if there is an integer k such that for every integer $n \in \mathbb{Z}$, $n \in A$ if and only if $n + k \in A$. In other words, a period set is a (finite) union of doubly infinite arithmetic progressions of the same common difference. The following are clear.

1. If A is periodic, then so is its complement $\mathbb{Z} \setminus A$.
2. If A and B are periodic sets, so is their union, the period of the union being the lcm of the periods of the sets. For example, if $A_3 := \{3n : n \in \mathbb{Z}\}$ and $A_5 := \{5n : n \in \mathbb{Z}\}$, then $A_3 \cup A_5$ is the union of the arithmetic progressions of common difference 15, containing the terms 0, 3, 5, 6, 9, 10.
3. (2) extends to finite unions.

For each prime number p , let $A_p := \{np : n \in \mathbb{Z}\}$ consists of the multiples of p . This is clearly periodic. Suppose there are only finitely many primes. Then, the (finite) union $A := \bigcup_{p \text{ prime}} A_p$ is periodic, and so is its complement. This complement is clearly the set $\{-1, 1\}$, which, being finite, cannot be periodic. This contradiction shows that there are indeed infinitely many primes.

²*Math. Mag.*, 76 (2003) number 3.

Appendix: Euclid's proof³

The prime numbers or primes are the numbers

$$(A) \quad 2, 3, 5, 7, 11, 13, 17, 19, 23, 29, \dots$$

which cannot be resolved into smaller factors. ... We have to prove that there are infinitely many primes, *i.e.*, that the series (A) never comes to an end.

Let us suppose that it does, and that

$$2, 3, 5, \dots, P$$

is the complete series (so that P is the largest prime); and let us, on this hypothesis, consider the number Q defined by the formula

$$Q = (2 \cdot 3 \cdot 5 \cdots P) + 1.$$

It is plain that Q is not divisible by any of $2, 3, 5, \dots, P$; for it leaves the remainder 1 when divided by any one of these numbers. But, if not itself prime, it is divisible by *some* prime, and therefore there is a prime (which may be Q itself) greater than any of them. This contradicts our hypothesis, that there is no prime greater than P ; and therefore this hypothesis is false.

The proof is by *reductio ad absurdum*, and *reductio ad absurdum*, which Euclid loved so much, is one of a mathematician's finest weapon. It is a far finer gambit than any chess gambit: a chess player may offer the sacrifice of a pawn or even a prize, but a mathematician offers *the game*.

³G. H. Hardy's paraphrase. [Hardy, pp.95–96].

Appendix: The prime numbers below 20000

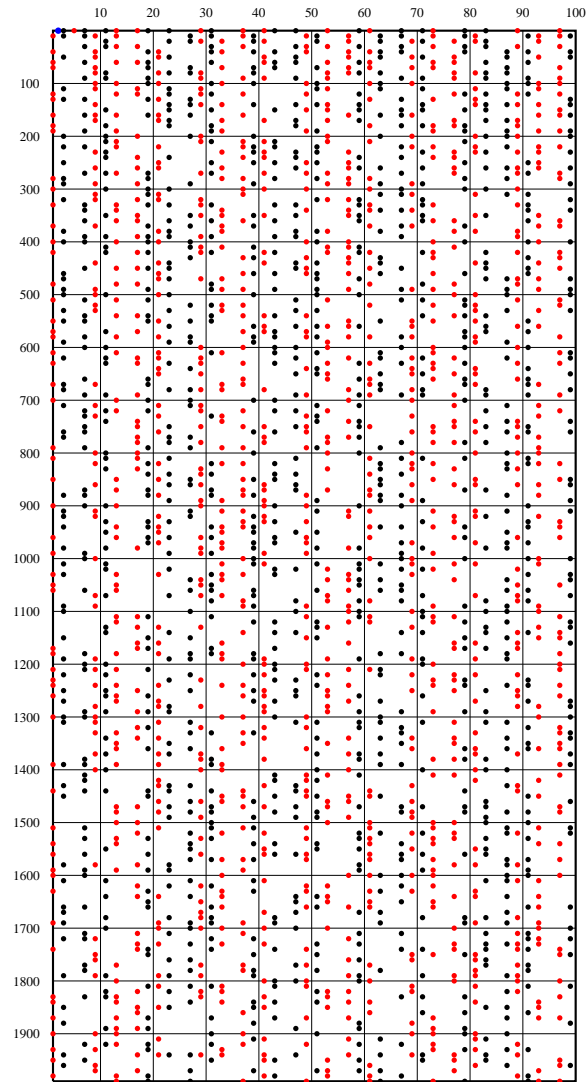

Exercise

1. Let p_n denote the n -th prime number. Find the smallest value of n for which $p_1 p_2 \cdots p_n + 1$ is not a prime number.
2. Find the smallest value of n for which $p_1 p_2 \cdots p_n - 1$ is not a prime number.
3. Find the smallest value of $n > 3$ for which $n! + 1$ is a prime number.
4. Find the smallest value of $n > 7$ for which $n! - 1$ is a prime number.
5. Find a shortest sequence of prime numbers $p_1 < p_2 < \cdots < p_n$ satisfying the following conditions.
 - (i) $p_1 = 2$,
 - (ii) $p_{k+1} < 2p_k$ for $k = 1, \dots, n - 1$,
 - (iii) $p_n > 10000$.

Project: Prime links

A prime link of length n is a permutation of $1, 2, \dots, n$ beginning with 1 and ending with n such that the sum of each pair of adjacent terms is prime. This was proposed and solved by Morris Wald [157]. For $n \leq 6$, the link is unique. For $n = 7$ there are two links: $1, 4, 3, 2, 5, 6, 7$ and $1, 6, 5, 2, 3, 4, 7$. Wald suggested working backwards. Start with n and precede it with the greatest remaining member of the set whose sum with n is a prime, and repeat in like fashion. Here are the first 10 links:

- 1.
- 1, 2.
- 1, 2, 3.
- 1, 2, 3, 4.
- 1, 4, 3, 2, 5.
- 1, 4, 3, 2, 5, 6.
- 1, 4, 3, 2, 5, 6, 7.
- 1, 2, 3, 4, 7, 6, 5, 8.
- 1, 2, 3, 4, 7, 6, 5, 8, 9.
- 1, 2, 3, 4, 7, 6, 5, 8, 9, 10.

Continue with larger values of n .

Project: Tuncatable primes

Consider the prime number 73939133. The numbers obtained by truncations from the right are all primes:

73939133, 7393913, 739391, 73939, 7393, 739, 73, 7.

More generally, we call a number N a right-truncatable prime if every number obtained from truncating N from the right is a prime or 1.

A complete list of right-truncatable primes can be found in [Waltrom and Berg].

Write a computer program to find all right-truncatable primes.

Similarly, define left-truncatable primes, and bi-truncatable primes as those which are both left- and right-truncatable primes.

53	3797	73331	7393931
	7331	373393	7393933
317	23333	593993	23399339
599	23339	719333	29399999
797	31193	739397	37337999
2393	31379	739399	59393339
3793	37397	2399333	73939133

Here are all the bi-truncatable primes:

1	2	3	5	7
11	13	17	23	31
37	53	71	73	113
131	137	173	311	313
317	373	1373	3137	

Chapter 22

Strings of prime numbers

- 1 The prime number spiral
 - 2 The prime number spiral beginning with 17
 - 3 The prime number spiral beginning with 41
- Appendix: The number spiral
Appendix: Long chains of primes
Appendix: Consecutive primes with consecutive prime digital sums
Projects

22.1 The prime number spiral

The first 1000 prime numbers arranged in a spiral.

- = prime of the form $4n + 1$;
- = prime of the form $4n + 3$.

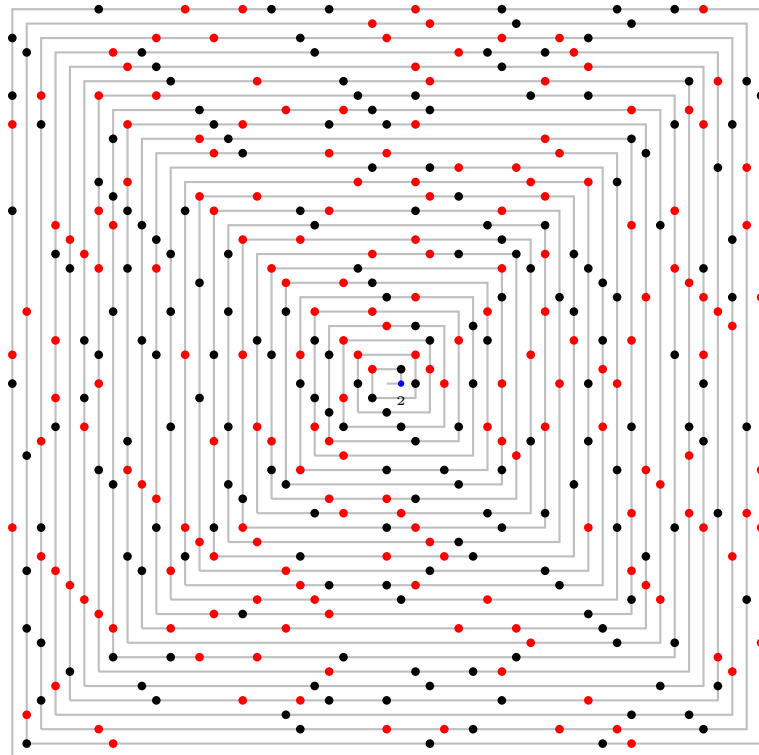

22.2 The prime number spiral beginning with 17

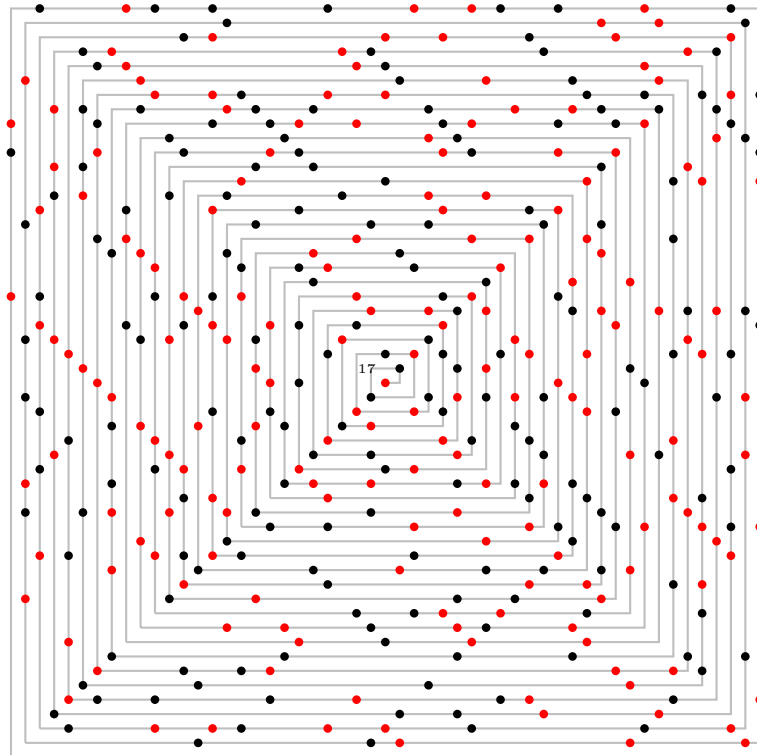

The numbers on the 45 degree line are $n^2 + n + 17$.

Let $f(n) = n^2 + n + 17$. The numbers $f(0), f(1), \dots, f(15)$ are all prime.

n	$f(n)$	n	$f(n)$	n	$f(n)$	n	$f(n)$
0	17	1	19	2	23	3	29
4	37	5	47	6	59	7	73
8	89	9	107	10	127	11	149
12	173	13	199	14	227	15	257

22.3 The prime number spiral beginning with 41

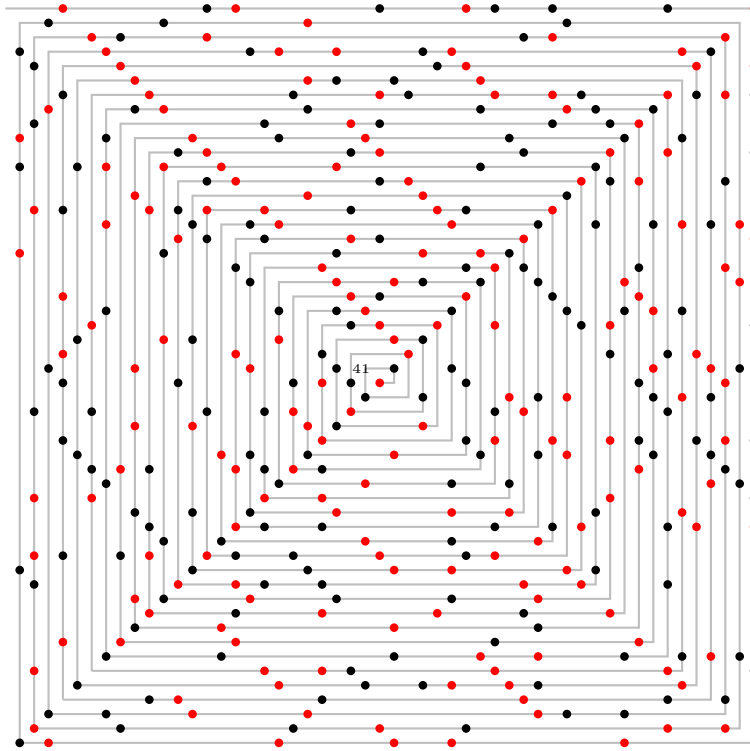

The numbers on the 45 degree line are $f(n) = n^2 + n + 41$.
 $f(n) = n^2 + n + 41$ is prime for $0 \leq n \leq 39$.

n	$f(n)$	n	$f(n)$	n	$f(n)$	n	$f(n)$	n	$f(n)$
0	41	1	43	2	47	3	53	4	61
5	71	6	83	7	97	8	113	9	131
10	151	11	173	12	197	13	223	14	251
15	281	16	313	17	347	18	383	19	421
20	461	21	503	22	547	23	593	24	641
25	691	26	743	27	797	28	853	29	911
30	971	31	1033	32	1097	33	1163	34	1231
35	1301	36	1373	37	1447	38	1523	39	1601

Prime number spiral beginning with 41: A closer look

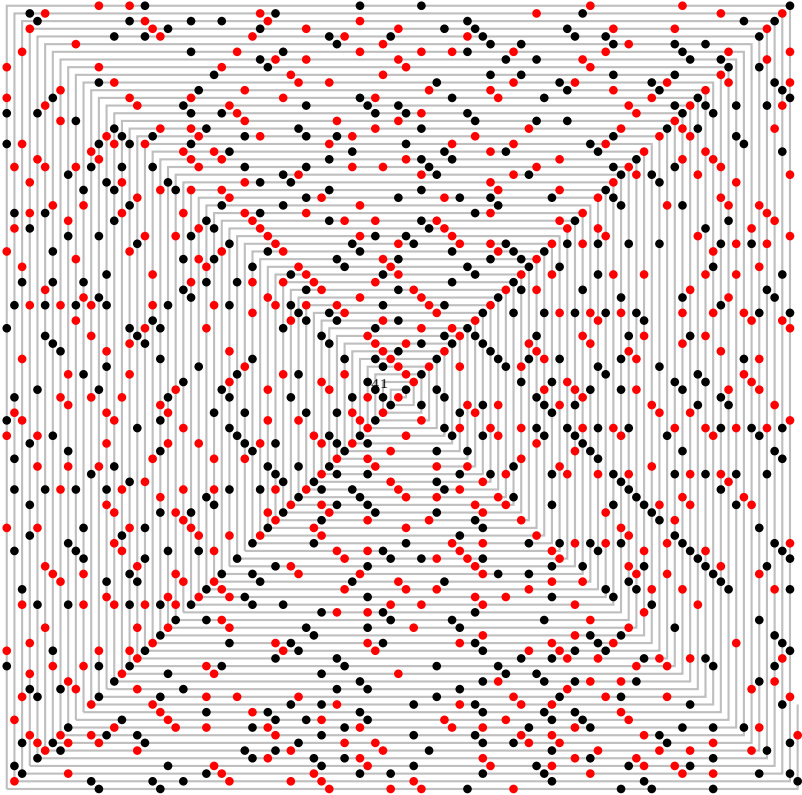

Appendix: The number spiral

Beginning with the origin, we trace out a spiral clockwise through the lattice points. Along with this, we label the lattice points $0, 1, 2, \dots$ consecutively.

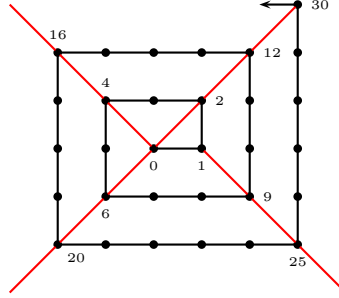

Given a positive integer N , let $(2m - 1)^2$ be the largest *odd* square $\leq N$, and write

$$N = (2m - 1)^2 + q, \quad 0 \leq q < 8m.$$

Then the number N appears at the lattice point

$$\begin{cases} (m, -m + q + 1) & \text{if } q \leq 2m - 1, \\ (3m - q - 1, m) & \text{if } 2m - 1 \leq q \leq 4m - 1, \\ (-m, 5m - q - 1) & \text{if } 4m - 1 \leq q \leq 6m - 1, \\ (-7m + q + 1, -m) & \text{if } 6m - 1 \leq q \leq 8m - 1. \end{cases}$$

Denote by $f(m, n)$ the number at the lattice point (m, n) .

It is clear that along the 45-degree line, $f(n, n) = 2n(2n - 1)$. Also,

$$f(-n, n) = 4n^2 \quad \text{if } n \geq 0,$$

and

$$f(n, -(n - 1)) = (2n - 1)^2 \quad \text{if } n > 0.$$

More generally,

$$f(m, n) = \begin{cases} 4m^2 - 3m + n & \text{if } m > |n|, \\ 4m^2 - m - n & \text{if } -m = |m| > |n|, \\ 4n^2 - n - m & \text{if } n > |m|, \\ 4n^2 - 3n + m & \text{if } -n = |n| > |m|. \end{cases}$$

Exercise

1. Label the vertices of a cube with the numbers 1 through 8 in such a way that the *sum* of the endpoints of each edge is prime.

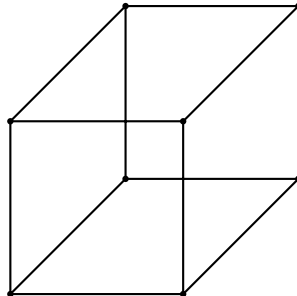

Appendix: Long chains of primes

Beiler [p.220] also considers the cubic function $f(n) = n^3 + n^2 + 17$, and noted that for $n = -14, -13, \dots, 10$, the string of 25 values are all primes. This is true only when we take -1 as a prime, since $f(-3) = -1$. Even if we break the string into two, we still get two long chains of primes:

$f(-14), f(-13), \dots, f(-4)$ a chain of 11 primes.

$f(-2), f(-1), f(0), \dots, f(10)$. But $f(0) = f(-1) = 17$, we only have 12 distinct primes.

Beyond these, the longest strings of primes have 6 members. The first of these begin with $n = 717$.

Note that on the negative side, there is a string of 10 consecutive primes from -183 to -174 . Replacing n by $-n$ we consider $n^3 - n - 17$ for $n = 174, \dots, 183$:

n	$n^3 + n^2 + 17$	factorization
173	5147771	683×7537
174	5237731	prime
175	5328733	prime
176	5420783	prime
177	5513887	prime
178	5608051	prime
179	5703281	prime
180	5799583	prime
181	5896963	prime
182	5995427	prime
183	6094981	prime
184	6195631	13×476587
185	6297383	prime

Higgins: 40 primes from $g(x) = 9x^2 - 231x + 1523$, $x = 0, \dots, 39$.
or $h(x) = 9x^2 - 471x + 6203$ give the same primes in reverse order.

Appendix: Consecutive primes with consecutive prime digital sums

Charles Twigg asked, in *Crux Math.*, Problem 228, for four consecutive primes having digital sums that, in some order, are consecutive primes. And then five.

The beginning of the prime number sequence provides an easy answer: just consider the primes 2, 3, 5, 7, or 3, 5, 7, 11. Beyond these, the first quadruple is 191, 193, 197, and 199, with digit sums 11, 13, 17, 19.

The five consecutive primes 311, 313, 317, 331, 337 all have prime digital sums, though these are the same for 313 and 331.

The first sequence of five consecutive primes whose digital sums form another sequence of 5 consecutive primes is

$$(1291, 13), (1297, 19), (1301, 5), (1303, 7), (1307, 11).$$

Twigg listed such quadruples and quintuples up to primes around 5 million (about 350000 primes). But within this range he had overlooked the better records

$$(102251, 11), (102253, 13), (102259, 19), (102293, 17), (102299, 23), (102301, 7)$$

and

$$\begin{array}{cccc} 3511973, 29 & 3511993, 31 & 3511999, 37 & 3512011, 13 \\ 3512051, 17 & 3512053, 19 & 3512057, 23 & \end{array}$$

A little bit beyond these we find the best record for eight up to the first 1 million primes:

$$\begin{array}{cccc} 5919931, 37 & 5919937, 43 & 5919959, 47 & 5919971, 41 \\ 5920003, 19 & 5920043, 23 & 5920049, 29 & 5920069, 31 \end{array}$$

Within the same range, there are also 15 consecutive primes whose digital sums are primes, though only with 5 different values:

$$\begin{array}{cccccc} 2442113, 17 & 2442133, 19 & 2442151, 19 & 2442173, 23 & 2442179, 29 \\ 2442191, 23 & 2442197, 29 & 2442199, 31 & 2442227, 23 & 2442263, 23 \\ 2442287, 29 & 2442289, 31 & 2442311, 17 & 2442353, 23 & 2442359, 29 \end{array}$$

Another “long” chain of 9 consecutive primes with 5 different consecutive prime digital sums can be found among “small” primes:

$$\begin{array}{cccccc} 14293, 19 & 14303, 11 & 14321, 11 & 14323, 13 & 14327, 17 \\ 14341, 13 & 14347, 19 & 14369, 23 & 14387, 23 & \end{array}$$

Chapter 23

Strings of composites

- 1 Strings of consecutive composite numbers
- 2 Strings of consecutive composite values of $n^2 + 1$
- 3 Strings of consecutive composite values of $n^2 + n + 41$
Appendix: 50 consecutive composite values of $x^2 + x + 41$
Project

23.1 Strings of consecutive composite numbers

It is well known that there are strings of consecutive composite numbers of arbitrary lengths. For example, the n numbers

$$(n + 1)! + 2, (n + 1)! + 3, \dots, (n + 1)! + (n + 1)$$

are all composites. These numbers are, however, very large.

In the table below, we give the first string of n consecutive composite numbers.

n	first string of n composite numbers
3	8...10
5	24...28
7	90...96
13	114...126
17	524...540
19	888...906
21	1130...1150
33	1328...1360
35	9552...9586
43	15684...15726
51	19610...19660
71	31398...31468
85	155922...156006
95	360654...360748
111	370262...370372
113	492114...492226
117	1349534...1349650
131	1357202...1357332
147	2010734...2010880
153	4652354...4652506
179	17051708...17051886
209	20831324...20831532

The first string of 100 consecutive composite numbers begins with 370262.¹ These are significantly less than 101!.

¹It actually extends to 370372, with 111 composite numbers. The string beginning with 396734 just misses by 1; it gives 99 consecutive composites.

23.2 Strings of consecutive composite values of $n^2 + 1$

m	$n \cdots n + m - 1$
3	7...9
9	27...35
13	41...53
15	95...109
19	185...203
33	351...383
39	497...535
45	3391...3435
87	3537...3623
99	45371...45469
111	82735...82845
129	99065...99193
151	357165...357315
211	840905...841115

23.3 Consecutive composite values of $x^2 + x + 41$

Problem 142 of *Crux Mathematicorum* asks for 40 consecutive positive integer values of x for which $f(x) = x^2 + x + 41$ are all composites. Several solutions were published. Unfortunately these numbers were quite large, being constructed by a method similar to the one above. For example, here is one. Since for $n = 0, \dots, 39$, $f(n) \leq f(39) = 1601$, if we set $x_n = 1601! + n$, then

$$f(x_n) = x_n^2 + x_n + 41 = (1601!) \cdot (1601! + 2n + 1) + f(n)$$

is a multiple of $f(n)$ which is greater than $f(n)$. These numbers are therefore composite. These numbers are quite large since $1601!$ has 4437 digits. The *Crux* editor wrote that “[i]t would be interesting if some computer nut were to make a search and discover the smallest set of 40 consecutive integers x for which $f(x)$ is composite”.

A near miss is 176955. The string of 38 consecutive numbers beginning with this all give composite $f(x)$. H. L. Nelson, then (and now) editor of *Journal of Recreational Mathematics*, found this smallest string, with factorization of the corresponding $f(x)$. It begins with 1081296.

There are longer strings.² Up to 5,000,000, the longest string of composites has 50 numbers. There are three such strings, beginning with 2561526, 3033715, and 3100535 respectively. See Appendix 2 for the first of these strings.

How about long strings of primes? They are relatively few. The only strings of ≥ 10 consecutive primes begin with 66, 191, 219, 534, and 179856, and no more up to 5,000,000. Each of these strings contains 10 primes, except the one beginning with 219, which contains 13 primes.

²For example, beginning with 1204431, we have a string of 45 composites.

Appendix: 50 consecutive composite values of $x^2 + x + 41$

x	$x^2 + x + 41$	Factorization
2561525	6561412887191	prime
2561526	6561418010243	1693357×3874799
2561527	6561423133297	1097×5981242601
2561528	6561428256353	$167 \times 971 \times 40463429$
2561529	6561433379411	499×13149165089
2561530	6561438502471	$167 \times 797 \times 853 \times 57793$
2561531	6561443625533	773×8488284121
2561532	6561448748597	$71 \times 133261 \times 693487$
2561533	6561453871663	$379 \times 7591 \times 2280667$
2561534	6561458994731	1512947×4336873
2561535	6561464117801	39233×167243497
2561536	6561469240873	$347 \times 2339 \times 8084281$
2561537	6561474363947	367×17878676741
2561538	6561479487023	3049×2152010327
2561539	6561484610101	$53 \times 83 \times 661 \times 2256559$
2561540	6561489733181	3947×1662399223
2561541	6561494856263	10501×624844763
2561542	6561499979347	3557×1844672471
2561543	6561505102433	71×92415564823
2561544	6561510225521	47×139606600543
2561545	6561515348611	722317×9083983
2561546	6561520471703	$53 \times 4973 \times 24894887$
2561547	6561525594797	2927×2241723811
2561548	6561530717893	419×15659977847
2561549	6561535840991	$47^2 \times 2970364799$
2561550	6561540964091	2003×3275856697
2561551	6561546087193	$43 \times 919 \times 1039 \times 159811$
2561552	6561551210297	$83 \times 12577 \times 6285667$
2561553	6561556333403	151×43454015453
2561554	6561561456511	43×152594452477
2561555	6561566579621	653×10048340857
2561556	6561571702733	41×160038334213
2561557	6561576825847	41×160038459167
2561558	6561581948963	2053×3196094471
2561559	6561587072081	9049×725117369
2561560	6561592195201	$1601 \times 8933 \times 458797$
2561561	6561597318323	1994669×3289567
2561562	6561602441447	$691 \times 23689 \times 400853$
2561563	6561607564573	4111×1596109843
2561564	6561612687701	$131 \times 419 \times 1259 \times 94951$
2561565	6561617810831	238363×27527837
2561566	6561622933963	4783×1371863461
2561567	6561628057097	2039×3218061823
2561568	6561633180233	$61 \times 97 \times 1108945949$
2561569	6561638303371	694367×9449813
2561570	6561643426511	$5417 \times 6529 \times 185527$
2561571	6561648549653	347×18909649999
2561572	6561653672797	4933×1330154809
2561573	6561658795943	5839×1123764137
2561574	6561663919091	$151 \times 397 \times 109457753$
2561575	6561669042241	$313 \times 1999 \times 10487143$
2561576	6561674165393	prime

Project: Strings of consecutive composite values of $n^2 + n + 1$

Find the first strings of consecutive composite values of $n^2 + n + 1$.

$$\begin{array}{r} m \quad n \cdots n + m - 1 \\ \hline 3 \quad 9 \cdots 11 \\ 5 \quad 28 \cdots 32 \end{array}$$

Project

The first string of 99 consecutive composite values of $n^2 + 1$ begins with $n = 45371$. The string with more than 100 composite values of $n^2 + 1$ has 111 members beginning with 82735. What is the longest of such a string you can find?

Chapter 24

Perfect numbers

- 1 Perfect numbers
 - 2 Charles Twigg on the first 10 perfect numbers
 - 3 Abundant and deficient numbers
- Appendix: Mersenne primes
- Appendix: Three important number theoretic functions
- Exercise

24.1 Perfect numbers

A number is perfect if the sum of its proper divisors (including 1) is equal to the number itself.

Theorem 24.1 (Euclid). *If $1 + 2 + 2^2 + \dots + 2^{k-1} = 2^k - 1$ is a prime number, then $2^{k-1}(2^k - 1)$ is a perfect number.*

Note: $2^k - 1$ is usually called the k -th Mersenne number and denoted by M_k . If M_k is prime, then k must be prime.

Theorem 24.2 (Euler). *Every even perfect number is of the form given by Euclid.*

Open problem

Does there exist an *odd* perfect number?

Theorem-joke 24.1 (Hendrik Lenstra). *Perfect squares do not exist.*¹

Proof. Suppose n is a perfect square. Look at the odd divisors of n . They all divide the largest of them, which is itself a square, say d^2 . This shows that the odd divisors of n come in pairs a, b where $a \cdot b = d^2$. Only d is paired to itself. Therefore the number of odd divisors of n is also odd. In particular, it is not $2n$. Hence n is not perfect, a contradiction: perfect squares don't exist. \square

¹*Math. Intelligencer*, 13 (1991) 40.

24.2 Charles Twigg on the first 10 perfect numbers

There are only 39 known Mersenne primes, and therefore 39 known perfect numbers. See Appendix. Let P_n be the n -th perfect number.

n	k	M_k	$P_n = 2^{k-1} M_k$
1	2	3	6
2	3	7	28
3	5	31	496
4	7	127	8128
5	13	8191	33550336
6	17	131071	8589869056
7	19	524287	137438691328
8	31	2147483647	2305843008139952128
9	61	2305843009213693951	2658455991569831744654692615953842176
10	89	618970019642690137449562111	191561942608236107294793378084303638130997321548169216

- P_1 is the difference of the digits of P_2 . In P_2 , the units digit is the cube of the of tens digit.
- P_3 and P_4 are the first two perfect numbers prefaced by squares. The first two digits of P_3 are consecutive squares. The first and last digits of P_4 are like cubes. The sums of the digits of P_3 and P_4 are the same, namely, the prime 19.
- P_4 terminates both P_{11} and P_{14} .²
- Three repdigits are imbedded in P_5 .
- P_7 contains each of the ten decimal digits except 0 and 5.
- P_9 is the smallest perfect number to contain each of the nine nonzero digits at least once. It is zerofree.
- P_{10} is the smallest perfect number to contain each of the ten decimal digits at least once.

²These contain respectively 65 and 366 digits.

24.3 Abundant and deficient numbers

A number n is abundant, perfect, or deficient if the sum of its proper divisors (including 1 but excluding n itself) is greater than, equal to, or less than n . If we denote by $\sigma(n)$ the sum of *all* divisors of n , including 1 and n itself, then n is abundant, perfect, or deficient according as $\sigma(n)$ is greater than, equal to, or less than $2n$. The advantage of using $\sigma(n)$ is that it can be easily computed if we know how n factors into primes:

Abundant numbers up to 200:

12	18	20	24	30	36	40	42	48	54	56	60	66	70	72
78	80	84	88	90	96	100	102	104	108	112	114	120	126	132
138	140	144	150	156	160	162	168	174	176	180	186	192	196	198
200														

Deficient *even* numbers up to 200:

2	4	8	10	14	16	22	26	32	34	38	44	46	50	52
58	62	64	68	74	76	82	86	92	94	98	106	110	116	118
122	124	128	130	134	136	142	146	148	152	154	158	164	166	170
172	178	182	184	188	190	194								

All multiples of 6 are abundant. But not conversely. 20 is abundant. 945 is the first odd abundant number.

5775 and 5776 are the first pair of abundant numbers.

Pairs of consecutive abundant numbers up to 10,000:

5775, 5776	5984, 5985	7424, 7425	11024, 11025
21735, 21736	21944, 21945	26144, 26145	27404, 27405
39375, 39376	43064, 43065	49664, 49665	56924, 56925
58695, 58696	61424, 61425	69615, 69616	70784, 70785
76544, 76545	77175, 77176	79695, 79696	81080, 81081
81675, 81676	82004, 82005	84524, 84525	84644, 84645
89775, 89776	91664, 91665	98175, 98176	...

The first triple of abundant numbers ³

n	factorization	$\sigma(n)$	$\sigma(n) - 2n$
171078830	$2 \cdot 5 \cdot 13 \cdot 23 \cdot 29 \cdot 1973$	358162560	16004900
171078831	$3^3 \cdot 7 \cdot 11 \cdot 19 \cdot 61 \cdot 71$	342835200	677538
171078832	$2^4 \cdot 31 \cdot 344917$	342158656	992

³Discovered in 1975 by Laurent Hodges and Reid, [Pickover, p. 364].

Appendix: Mersenne primes

Primes of the form $M_k = 2^k - 1$ are called Mersenne prime. The only known Mersenne primes are listed below.

k	Year	Discoverer	k	Year	Discoverer
17	1588	P.A.Cataldi	19	1588	P.A.Cataldi
31	1750	L.Euler	61	1883	I.M.Pervushin
89	1911	R.E.Powers	107	1913	E.Fauquembergue
127	1876	E.Lucas	521	1952	R.M.Robinson
607	1952	R.M.Robinson	1279	1952	R.M.Robinson
2203	1952	R.M.Robinson	2281	1952	R.M.Robinson
3217	1957	H.Riesel	4253	1961	A.Hurwitz
4423	1961	A.Hurwitz	9689	1963	D.B.Gillies
9941	1963	D.B.Gillies	11213	1963	D.B.Gillies
19937	1971	B.Tuckerman	21701	1978	C.Noll, L.Nickel
23209	1979	C.Noll	44497	1979	H.Nelson, D.Slowinski
86243	1982	D.Slowinski	110503	1988	W.N.Colquitt, L.Welsch
132049	1983	D.Slowinski	216091	1985	D.Slowinski
756839	1992	D.Slowinski,P.Gage	859433	1993	D.Slowinski
1257787	1996	Slowinski and Gage	1398269	1996	Armengaud, Woltman et al.
2976221	1997	Spence, Woltman, et.al.	3021377	1998	Clarkson, Woltman, Kurowski et. al.
6972593	1999	Hajratwala, Woltman, Kurowski et. al.	13466917	2001	Cameron, Woltman, Kurowski et. al.

$M_{13466917}$ has 4053946 digits and is the largest known prime.

Appendix: Three important number theoretic functions

Let n be a positive integer with prime factorization

$$n = \prod_{i=1}^k p_i^{a_i}$$

There are several important numbers associated with n .

1. The number of divisors of n is

$$d(n) = \prod_{i=1}^k (1 + a_i).$$

2. The sum of divisors of n , including 1 and n itself, is

$$\sigma(n) = \prod_{i=1}^k \frac{p_i^{a_i+1} - 1}{p_i - 1}.$$

3. The number of positive integers $< n$ which are relatively prime to n is given by

$$\phi(n) = n \prod_{i=1}^k \left(1 - \frac{1}{p_i}\right).$$

These functions are all multiplicative in the sense that

$$f(mn) = f(m)f(n) \quad \text{whenever } \gcd(m, n) = 1.$$

24.3.1 Appendix: Two enumerations of the rational numbers in (0,1)

Consider two enumerations of the rational numbers in (0,1).

E_1 lists them by increasing denominator, and for equal denominators, by increasing numerator. Thus,

$$E_1 : \frac{1}{2}, \frac{1}{3}, \frac{2}{3}, \frac{1}{4}, \frac{3}{4}, \frac{1}{5}, \frac{2}{5}, \frac{3}{5}, \frac{4}{5}, \frac{1}{6}, \frac{5}{6}, \dots$$

E_2 , on the other hand, lists them by increasing sum of numerator and denominator, and for equal sums of terms, by increasing numerator. Thus,

$$E_2 : \frac{1}{2}, \frac{1}{3}, \frac{1}{4}, \frac{2}{3}, \frac{1}{5}, \frac{1}{6}, \frac{2}{5}, \frac{3}{4}, \frac{1}{7}, \frac{3}{5}, \frac{1}{8}, \dots$$

The fractions $\frac{1}{2}$, $\frac{1}{3}$, and $\frac{2}{5}$ occupy the same positions in both sequences. More generally, the rational number $\frac{m}{n}$ (with $m < n$ and $\text{gcd}(m, n) = 1$) occupies position

$$\sum_{k=2}^{n-1} \phi(k) + \sum_{k=1}^m \chi(k, n)$$

in enumeration E_1 and position

$$\frac{1}{2} \sum_{k=3}^{m+n-1} \phi(k) + \sum_{k=1}^m \chi(k, m+n-k)$$

in enumeration E_2 . Here,

$$\chi(m, n) = \begin{cases} 1 & \text{if } \text{gcd}(m, n) = 1, \\ 0 & \text{otherwise.} \end{cases}$$

This was Computer Challenge 511 of *Journal of Recreational Mathematics*. The solution lists 10 of these. ⁴

Fraction	$\frac{1}{2}$	$\frac{1}{3}$	$\frac{2}{5}$	$\frac{9}{23}$	$\frac{30}{73}$	$\frac{59}{143}$	$\frac{67}{163}$	$\frac{97}{235}$	$\frac{197}{477}$	$\frac{513}{1238}$
Position	1	2	7	158	1617	6211	8058	16765	69093	465988

What is the next match? For $m + n \leq 20000$, I found four more:

Fraction	$\frac{1729}{4175}$	$\frac{1922}{4641}$	$\frac{3239}{7820}$	$\frac{4646}{11217}$
Position	5297983	6546724	18588348	38244610

⁴*Journal of Recreational Math.*, 10 (1977–78) 122–123.

Exercise

1. The isle of Pythagora, while very sparsely populated, is capable of supporting a population of thirty million. On the 6th day of the 28th anniversary of his accession to the throne, the king of the island called a meeting of his 496 advisors to decide how to celebrate the auspicious occasion. They decided to divide the regal jewels among the people of the land. All the people, including the king the advisors, were lined up in a single file, and the jewels were distributed as follows.

Starting with the second in line, each person was given one jewel.

Starting with the 4th in line, each second person was given two jewels.

Starting with the 6th in line, each third person was given three jewels.

Starting with the 8th in line, each fourth person was given four jewels, and so on.

The man at the extreme end of the line noticed that the number of jewels he received corresponded to his position in line.

How many people were there in Pythagora ?

2. A minimum security prison contains 100 cells with one prisoner in each. The athletic young warden was ordered to free a certain number of these prisoners at his discretion, and this is how he did it.

First he walked along the row of cells opening every door. Starting at the beginning again, he shuts every second door. During his third walk, starting at the beginning, he stopped at every third door: if it was open he shut it, if it was shut he opened it. On his fourth walk he did the same, opening closed doors and closing open doors, except he did it for every fourth door. On his fifth walk he stopped at every fifth door, closing it if it was open and opening it if it was shut. And so on, until at last he had completed the full hundred walks.

The prisoners in cells whose doors were still open were freed.

Which were the lucky cells?

3. For a positive integer n , show that if $\sigma(n)$ is prime, then so is $d(n)$.

Chapter 25

Routh and Ceva theorems

- 1 Routh theorem: an example
- 2 Routh theorem
- 3 Ceva theorem and coordinates of triangle centers
 - centroid
 - incenter
 - Gergonne point
 - Nagel point
 - Exercise

25.1 Routh theorem: an example

Given a triangle ABC , X, Y, Z are points on the side lines specified by the ratios of divisions

$$BX : XC = 2 : 1, \quad CY : YA = 5 : 3, \quad AZ : ZB = 3 : 2.$$

The lines AX, BY, CZ bound a triangle PQR . Suppose triangle ABC has area Δ . Find the area of triangle PQR .

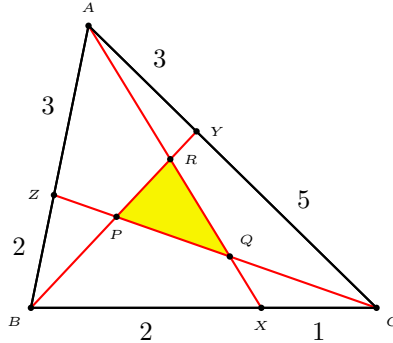

We make use of *homogeneous barycentric coordinates* with respect to ABC .

$$X = (0 : 1 : 2), \quad Y = (5 : 0 : 3), \quad Z = (2 : 3 : 0).$$

Those of P, Q, R can be worked out easily:

$P = BY \cap CZ$	$Q = CZ \cap AX$	$R = AX \cap BY$
$Y = (5 : 0 : 3)$	$Z = (2 : 3 : 0)$	$X = (0 : 1 : 2)$
$Z = (2 : 3 : 0)$	$X = (0 : 1 : 2)$	$Y = (5 : 0 : 3)$
$P = (10 : 15 : 6)$	$Q = (2 : 3 : 6)$	$R = (10 : 3 : 6)$

This means that the *absolute barycentric coordinates* of X, Y, Z are

$$P = \frac{1}{31}(10A + 15B + 6C), \quad Q = \frac{1}{11}(2A + 3B + 6C), \quad R = \frac{1}{19}(10A + 3B + 6C).$$

The area of triangle PQR

$$= \frac{1}{31 \cdot 11 \cdot 19} \begin{vmatrix} 10 & 15 & 6 \\ 2 & 3 & 6 \\ 10 & 3 & 6 \end{vmatrix} \cdot \Delta = \frac{576}{6479} \Delta.$$

25.2 Routh theorem

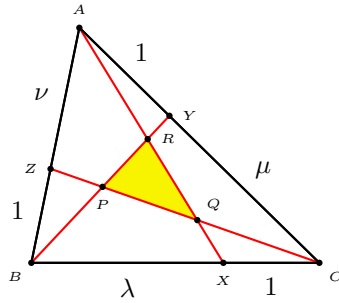

We make use of *homogeneous barycentric coordinates* with respect to ABC .

$$X = (0 : 1 : \lambda), \quad Y = (\mu : 0 : 1), \quad Z = (1 : \nu : 0).$$

Those of P, Q, R can be worked out easily:

$P = BY \cap CZ$	$Q = CZ \cap AX$	$R = AX \cap BY$
$Y = (\mu : 0 : 1)$	$Z = (1 : \nu : 0)$	$X = (0 : 1 : \lambda)$
$Z = (1 : \nu : 0)$	$X = (0 : 1 : \lambda)$	$Y = (\mu : 0 : 1)$
$P = (\mu : \mu\nu : 1)$	$Q = (1 : \nu : \nu\lambda)$	$R = (\lambda\mu : 1 : \lambda)$

This means that the *absolute barycentric coordinates* of X, Y, Z are

$$P = \frac{1}{\mu\nu + \mu + 1}(\mu A + \mu\nu B + C),$$

$$Q = \frac{1}{\nu\lambda + \nu + 1}(A + \nu B + \nu\lambda C),$$

$$R = \frac{1}{\lambda\mu + \lambda + 1}(\lambda\mu A + B + \lambda C).$$

From these,

$$\text{Area}(PQR) = \frac{\begin{vmatrix} \mu & \mu\nu & 1 \\ 1 & \nu & \nu\lambda \\ \lambda\mu & 1 & \lambda \end{vmatrix}}{(\mu\nu + \mu + 1)(\nu\lambda + \nu + 1)(\lambda\mu + \lambda + 1)} \cdot \Delta$$

$$= \frac{(\lambda\mu\nu - 1)^2}{(\mu\nu + \mu + 1)(\nu\lambda + \nu + 1)(\lambda\mu + \lambda + 1)} \cdot \Delta.$$

25.3 Ceva Theorem

Theorem 25.1 (Ceva). *Let X, Y, Z be points on the lines BC, CA, AB respectively. The lines AX, BY, CZ are concurrent if and only if*

$$\frac{BX}{XC} \cdot \frac{CY}{YA} \cdot \frac{AZ}{ZB} = 1.$$

If this condition is satisfied, the homogeneous barycentric coordinates of the common point of AX, BY, CZ can be written down by combining the coordinates of X, Y, Z .

Example: centroid

If AX, BY, CZ are the medians, the intersection is the centroid G :

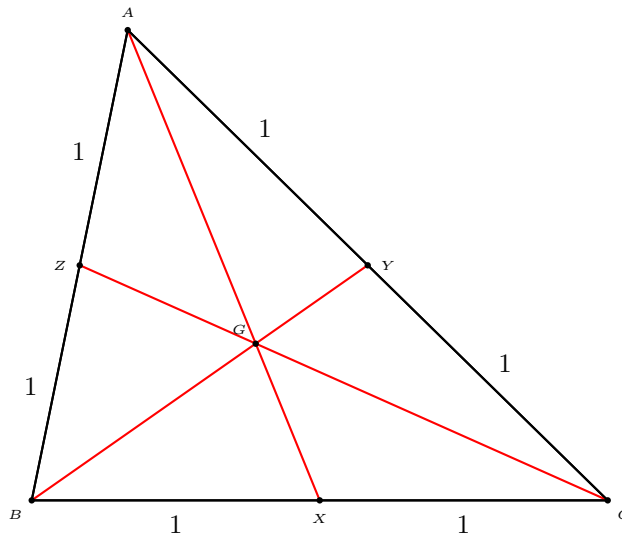

$$\begin{array}{r} X = (0 : 1 : 1) \\ Y = (1 : 0 : 1) \\ Z = (1 : 1 : 0) \\ \hline G = (1 : 1 : 1) \end{array}$$

Example: incenter

If AX , BY , CZ are the angle bisectors, the intersection is the incenter I :

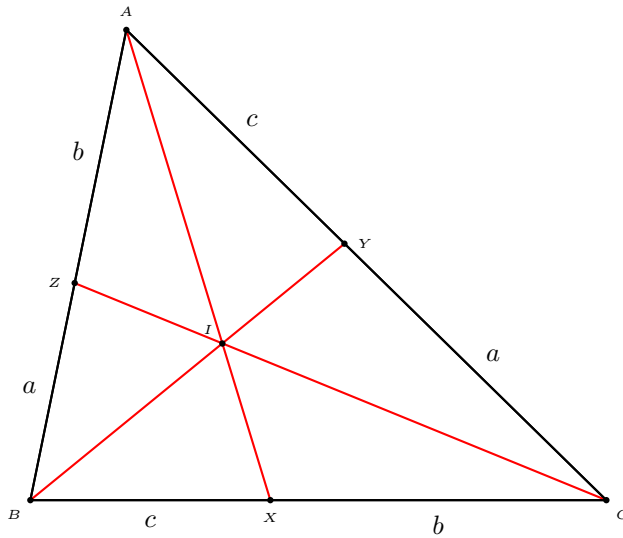

$$\begin{array}{r} X = (0 : b : c) \\ Y = (a : 0 : c) \\ Z = (a : b : 0) \\ \hline I = (a : b : c) \end{array}$$

Example: Gergonne point

If X, Y, Z are the points of tangency of the incircle with the sidelines, the lines AX, BY, CZ intersect at the Gergonne point.

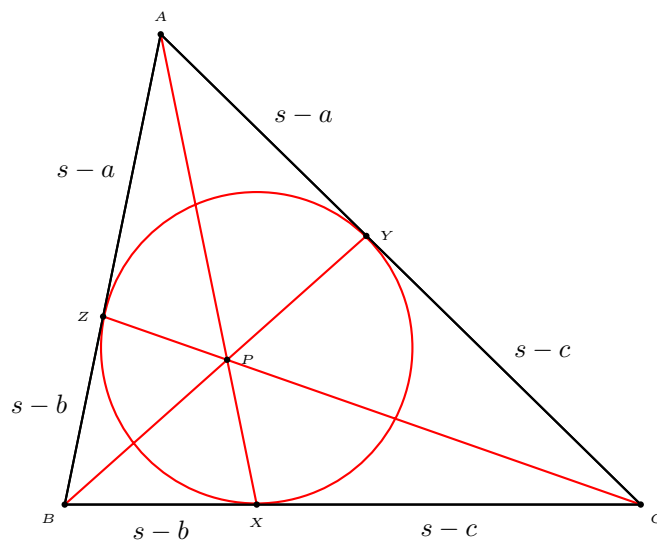

$$\begin{array}{l}
 X = (0 : s - c : s - b) = \left(0 : \frac{1}{s-b} : \frac{1}{s-c}\right) \\
 Y = (s - c : 0 : s - a) = \left(\frac{1}{s-a} : 0 : \frac{1}{s-c}\right) \\
 Z = (s - b : s - a : 0) = \left(\frac{1}{s-a} : \frac{1}{s-b} : 0\right) \\
 \hline
 P = = \left(\frac{1}{s-a} : \frac{1}{s-b} : \frac{1}{s-c}\right)
 \end{array}$$

Example: Nagel point

If X, Y, Z are the points of tangency of the excircles with the respective sidelines, the lines AX, BY, CZ intersect at the Nagel point.

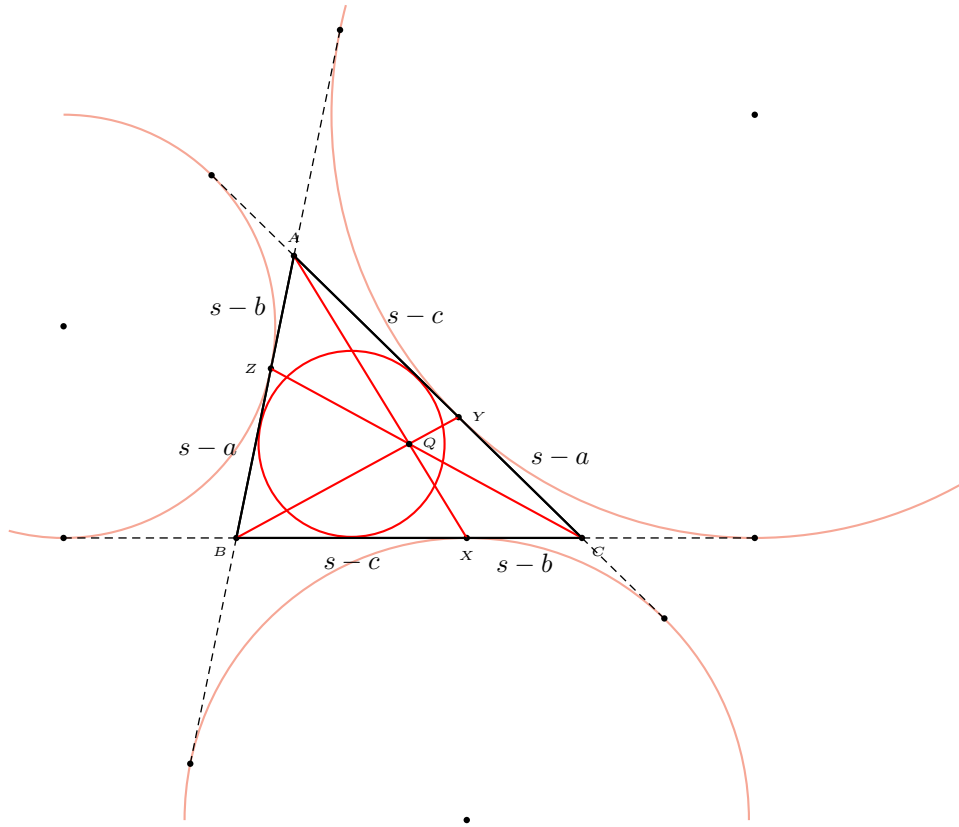

$$\begin{aligned} X &= (0 : s-b : s-c) \\ Y &= (s-a : 0 : s-c) \\ Z &= (s-a : s-b : 0) \\ \hline Q &= (s-a : s-b : s-c) \end{aligned}$$

Exercise

1. Calculate the area of triangle PQR given
 - (a) $\lambda = \mu = \nu = 2$.
 - (b) $\lambda = 1, \mu = 7, \nu = 4$;
 - (c) $\lambda = 3, \mu = 7, \nu = 6$.
2. Calculate the homogeneous barycentric coordinates of the ortho-center of triangle ABC .

Project

In the Routh formula, how should one choose integer values for λ , μ , and ν so that the area of triangle PQR is $\frac{1}{n}$ of that of triangle ABC for an integer n ?

Appendix

We give those values of λ, μ, ν with numerators and denominators < 10 for which the area of triangle PQR is k times that of ABC with the numerator and denominator of k less than 10.

λ	μ	ν	k	λ	μ	ν	k	λ	μ	ν	k	λ	μ	ν	k
1	4	9	1	1	1	8	1	1	3	1	1	1	9	4	1
1	5	8	1	1	2	5	1	1	8	1	1	1	5	7	1
1	6	7	1	1	3	4	1	1	7	1	1	1	6	6	1
1	7	6	1	1	4	3	1	1	6	1	1	1	5	5	1
1	8	5	1	1	5	2	1	1	5	1	1	1	4	4	1
1	9	4	1	1	6	1	1	1	4	1	1	1	3	3	1
1	10	3	1	1	7	1	1	1	3	1	1	1	2	2	1
1	11	2	1	1	8	1	1	1	2	1	1	1	1	1	1
1	12	1	1	1	9	1	1	1	1	1	1	1	1	1	1
1	13	1	1	1	10	1	1	1	1	1	1	1	1	1	1
1	14	1	1	1	11	1	1	1	1	1	1	1	1	1	1
1	15	1	1	1	12	1	1	1	1	1	1	1	1	1	1
1	16	1	1	1	13	1	1	1	1	1	1	1	1	1	1
1	17	1	1	1	14	1	1	1	1	1	1	1	1	1	1
1	18	1	1	1	15	1	1	1	1	1	1	1	1	1	1
1	19	1	1	1	16	1	1	1	1	1	1	1	1	1	1
1	20	1	1	1	17	1	1	1	1	1	1	1	1	1	1
1	21	1	1	1	18	1	1	1	1	1	1	1	1	1	1
1	22	1	1	1	19	1	1	1	1	1	1	1	1	1	1
1	23	1	1	1	20	1	1	1	1	1	1	1	1	1	1
1	24	1	1	1	21	1	1	1	1	1	1	1	1	1	1
1	25	1	1	1	22	1	1	1	1	1	1	1	1	1	1
1	26	1	1	1	23	1	1	1	1	1	1	1	1	1	1
1	27	1	1	1	24	1	1	1	1	1	1	1	1	1	1
1	28	1	1	1	25	1	1	1	1	1	1	1	1	1	1
1	29	1	1	1	26	1	1	1	1	1	1	1	1	1	1
1	30	1	1	1	27	1	1	1	1	1	1	1	1	1	1
1	31	1	1	1	28	1	1	1	1	1	1	1	1	1	1
1	32	1	1	1	29	1	1	1	1	1	1	1	1	1	1
1	33	1	1	1	30	1	1	1	1	1	1	1	1	1	1
1	34	1	1	1	31	1	1	1	1	1	1	1	1	1	1
1	35	1	1	1	32	1	1	1	1	1	1	1	1	1	1
1	36	1	1	1	33	1	1	1	1	1	1	1	1	1	1
1	37	1	1	1	34	1	1	1	1	1	1	1	1	1	1
1	38	1	1	1	35	1	1	1	1	1	1	1	1	1	1
1	39	1	1	1	36	1	1	1	1	1	1	1	1	1	1
1	40	1	1	1	37	1	1	1	1	1	1	1	1	1	1
1	41	1	1	1	38	1	1	1	1	1	1	1	1	1	1
1	42	1	1	1	39	1	1	1	1	1	1	1	1	1	1
1	43	1	1	1	40	1	1	1	1	1	1	1	1	1	1
1	44	1	1	1	41	1	1	1	1	1	1	1	1	1	1
1	45	1	1	1	42	1	1	1	1	1	1	1	1	1	1
1	46	1	1	1	43	1	1	1	1	1	1	1	1	1	1
1	47	1	1	1	44	1	1	1	1	1	1	1	1	1	1
1	48	1	1	1	45	1	1	1	1	1	1	1	1	1	1
1	49	1	1	1	46	1	1	1	1	1	1	1	1	1	1
1	50	1	1	1	47	1	1	1	1	1	1	1	1	1	1
1	51	1	1	1	48	1	1	1	1	1	1	1	1	1	1
1	52	1	1	1	49	1	1	1	1	1	1	1	1	1	1
1	53	1	1	1	50	1	1	1	1	1	1	1	1	1	1
1	54	1	1	1	51	1	1	1	1	1	1	1	1	1	1
1	55	1	1	1	52	1	1	1	1	1	1	1	1	1	1
1	56	1	1	1	53	1	1	1	1	1	1	1	1	1	1
1	57	1	1	1	54	1	1	1	1	1	1	1	1	1	1
1	58	1	1	1	55	1	1	1	1	1	1	1	1	1	1
1	59	1	1	1	56	1	1	1	1	1	1	1	1	1	1
1	60	1	1	1	57	1	1	1	1	1	1	1	1	1	1
1	61	1	1	1	58	1	1	1	1	1	1	1	1	1	1
1	62	1	1	1	59	1	1	1	1	1	1	1	1	1	1
1	63	1	1	1	60	1	1	1	1	1	1	1	1	1	1
1	64	1	1	1	61	1	1	1	1	1	1	1	1	1	1
1	65	1	1	1	62	1	1	1	1	1	1	1	1	1	1
1	66	1	1	1	63	1	1	1	1	1	1	1	1	1	1
1	67	1	1	1	64	1	1	1	1	1	1	1	1	1	1
1	68	1	1	1	65	1	1	1	1	1	1	1	1	1	1
1	69	1	1	1	66	1	1	1	1	1	1	1	1	1	1
1	70	1	1	1	67	1	1	1	1	1	1	1	1	1	1
1	71	1	1	1	68	1	1	1	1	1	1	1	1	1	1
1	72	1	1	1	69	1	1	1	1	1	1	1	1	1	1
1	73	1	1	1	70	1	1	1	1	1	1	1	1	1	1
1	74	1	1	1	71	1	1	1	1	1	1	1	1	1	1
1	75	1	1	1	72	1	1	1	1	1	1	1	1	1	1
1	76	1	1	1	73	1	1	1	1	1	1	1	1	1	1
1	77	1	1	1	74	1	1	1	1	1	1	1	1	1	1
1	78	1	1	1	75	1	1	1	1	1	1	1	1	1	1
1	79	1	1	1	76	1	1	1	1	1	1	1	1	1	1
1	80	1	1	1	77	1	1	1	1	1	1	1	1	1	1
1	81	1	1	1	78	1	1	1	1	1	1	1	1	1	1
1	82	1	1	1	79	1	1	1	1	1	1	1	1	1	1
1	83	1	1	1	80	1	1	1	1	1	1	1	1	1	1
1	84	1	1	1	81	1	1	1	1	1	1	1	1	1	1
1	85	1	1	1	82	1	1	1	1	1	1	1	1	1	1
1	86	1	1	1	83	1	1	1	1	1	1	1	1	1	1
1	87	1	1	1	84	1	1	1	1	1	1	1	1	1	1
1	88	1	1	1	85	1	1	1	1	1	1	1	1	1	1
1	89	1	1	1	86	1	1	1	1	1	1	1	1	1	1
1	90	1	1	1	87	1	1	1	1	1	1	1	1	1	1
1	91	1	1	1	88	1	1	1	1	1	1	1	1	1	1
1	92	1	1	1	89	1	1	1	1	1	1	1	1	1	1
1	93	1	1	1	90	1	1	1	1	1	1	1	1	1	1
1	94	1	1	1	91	1	1	1	1	1	1	1	1	1	1
1	95	1	1	1	92	1	1	1	1	1	1	1	1	1	1
1	96	1	1	1	93	1	1	1	1	1	1	1	1	1	1
1	97	1	1	1	94	1	1	1	1	1	1	1	1	1	1
1	98	1	1	1	95	1	1	1	1	1	1	1	1	1	1
1	99	1	1	1	96	1	1	1	1	1	1	1	1	1	1
1	100	1	1	1	97	1	1	1	1	1	1	1	1	1	1
1	101	1	1	1	98	1	1	1	1	1	1	1	1	1	1
1	102	1	1	1	99	1	1	1	1	1	1	1	1	1	1
1	103	1	1	1	100	1	1	1	1	1	1	1	1	1	1
1	104	1	1	1	101	1	1	1	1	1	1	1	1	1	1
1	105	1	1	1	102	1	1	1	1	1	1	1	1	1	1
1	106	1	1	1	103	1	1	1	1	1	1	1	1	1	1
1	107	1	1	1	104	1	1	1	1	1	1	1	1	1	1
1	108	1	1	1	105	1	1	1	1	1	1	1	1	1	1
1	109	1	1	1	106	1	1	1	1	1	1	1	1	1	1
1	110	1	1	1	107	1	1	1	1	1	1	1	1	1	1
1	111	1	1	1	108	1	1	1	1	1	1	1	1	1	1
1	112	1	1	1	109	1	1	1	1	1	1	1	1	1	1
1	113	1	1	1	110	1	1	1	1	1	1	1	1	1	1
1	114	1	1	1	111	1	1	1	1	1	1	1	1	1	1
1	115	1	1	1	112	1	1	1	1	1	1	1	1	1	1
1	116	1	1	1	113	1	1	1	1	1	1	1	1	1	1
1	117	1	1	1	114	1	1	1	1	1	1	1	1	1	1
1	118	1	1	1	115	1	1	1	1	1	1	1	1	1	1
1	119	1	1	1	116	1	1	1							

Chapter 26

The excircles

- 1 Feuerbach theorem
 - 2 A relation among radii
 - 3 The circumcircle of the excentral triangle
 - 4 The radical circle of the excircles
 - 5 Apollonius circle: the circular hull of the excircles
- Appendix: Three mutually orthogonal circles with given centers

26.1 Feuerbach theorem

The nine-point circle is tangent internally to the incircle and externally to each of the excircles.

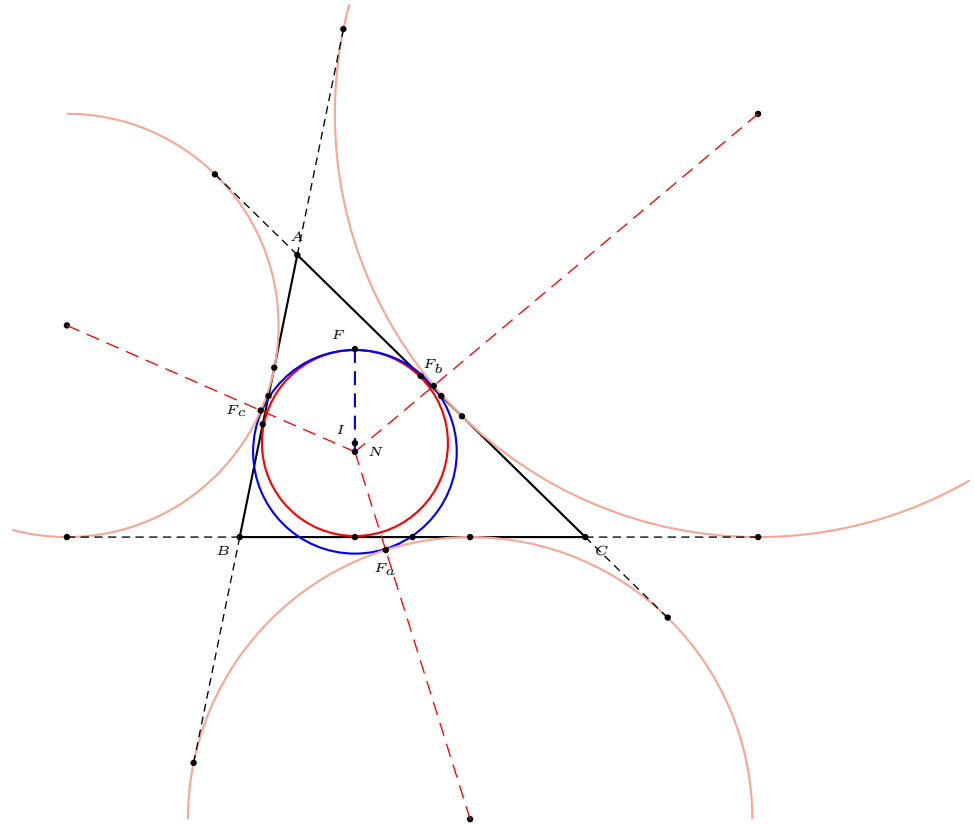

26.3 The circumcircle of the excentral triangle

The circle through the excenters has center at the reflection of the incenter in the circumcenter, and radius twice the circumradius.

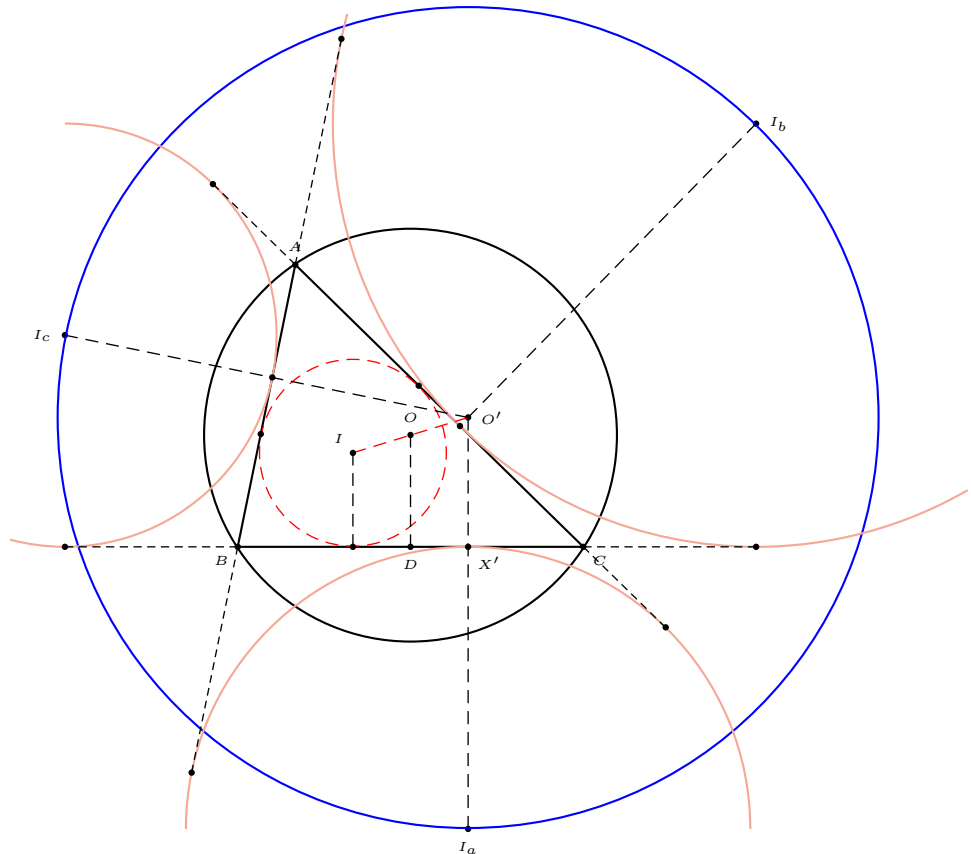

$$\begin{aligned}
 O'I_a &= r_a + O'X' \\
 &= r_a + 2OD - r \\
 &= r_a + 2(R - DM') - r && \text{(from previous page)} \\
 &= r_a + 2R - (r_a - r) - r \\
 &= 2R.
 \end{aligned}$$

Similarly, $O'I_b = O'I_c = 2R$.

26.4 The radical circle of the excircles

The circle orthogonal to each of the excircles has center at the Spieker point, the incenter of the medial triangle. Its radius is $\frac{1}{2}\sqrt{r^2 + s^2}$.

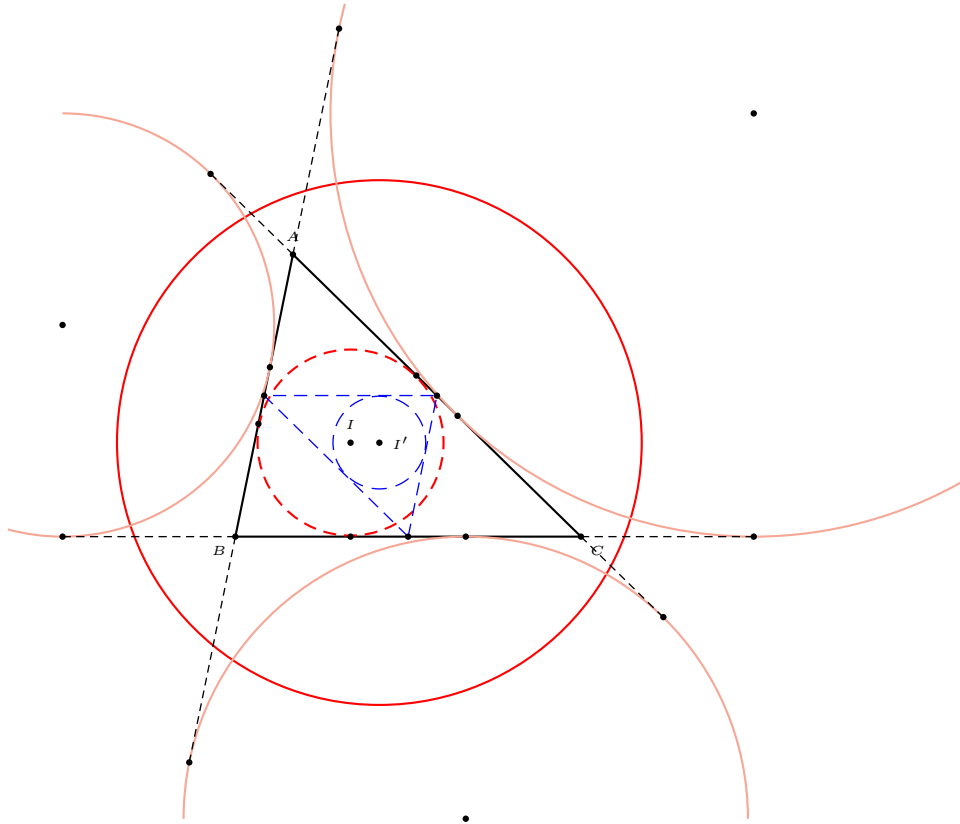

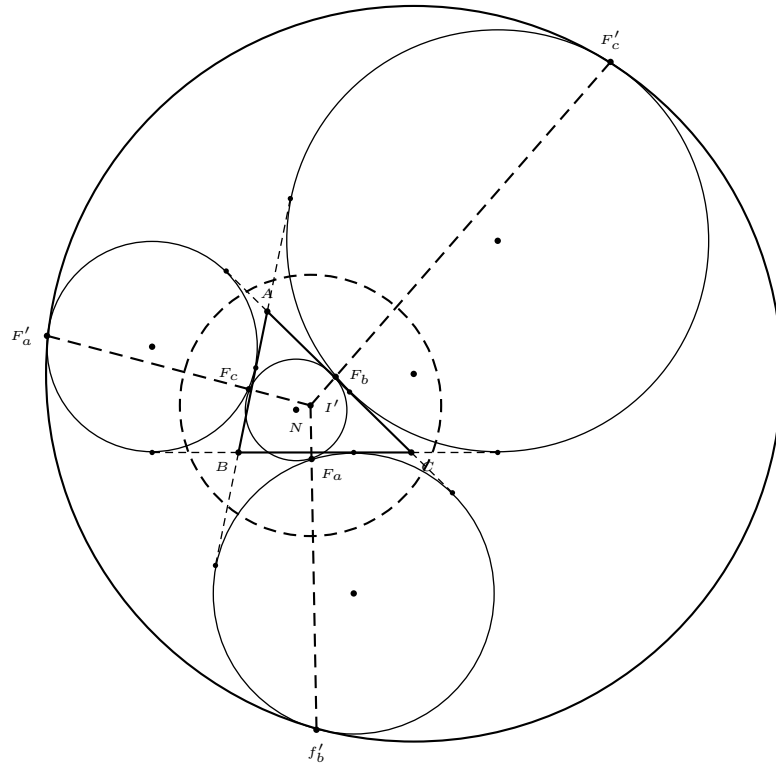
26.5 Apollonius circle: the circular hull of the excircles

Appendix: Three mutually orthogonal circles with given centers

Given three points A, B, C that form an acute-angled triangle, construct three circles with these points as centers that are mutually orthogonal to each other.

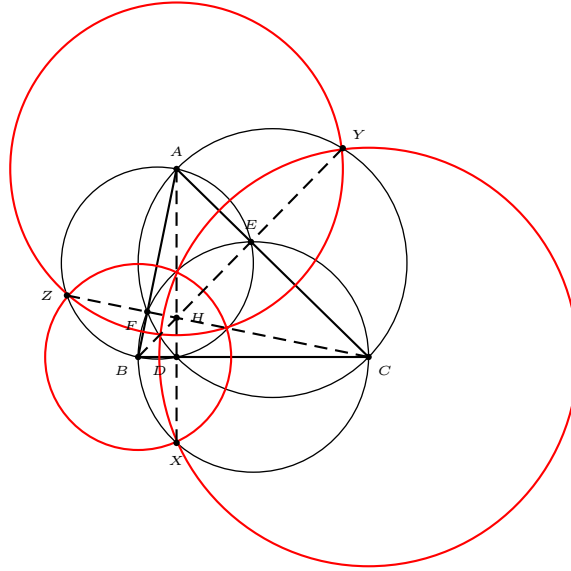

Solution

Let $BC = a$, $CA = b$, and $AB = c$. If these circles have radii r_a, r_b, r_c respectively, then

$$r_b^2 + r_c^2 = a^2, \quad r_c^2 + r_a^2 = b^2, \quad r_a^2 + r_b^2 = c^2.$$

From these,

$$r_a^2 = \frac{1}{2}(b^2 + c^2 - a^2), \quad r_b^2 = \frac{1}{2}(c^2 + a^2 - b^2), \quad r_c^2 = \frac{1}{2}(a^2 + b^2 - c^2).$$

These are all positive since ABC is an acute triangle. Consider the perpendicular foot E of B on AC . Note that $AE = c \cos A$, so that $r_a^2 = \frac{1}{2}(b^2 + c^2 - a^2) = bc \cos A = AC \cdot AE$. It follows if we extend BE to intersect at Y the semicircle constructed externally on the side AC as diameter, then, $AY^2 = AC \cdot AE = r_a^2$. Therefore we have the following simple construction of these circles. (1) With each side as diameter, construct a semicircle externally of the triangle. (2) Extend the altitudes of the triangle to intersect the semicircles on the same side. Label these X, Y, Z on the semicircles on BC, CA, AB respectively. These satisfy $AY = AZ, BZ = BX$, and $CX = CY$. (3) The circles $A(Y), B(Z)$ and $C(X)$ are mutually orthogonal to each other.

Chapter 27

Figurate numbers

27.1 Triangular numbers

The n th triangular number is

$$T_n = 1 + 2 + 3 + \cdots + n = \frac{1}{2}n(n+1).$$

The first few of these are 1, 3, 6, 10, 15, 21, 28, 36, 45, 55,

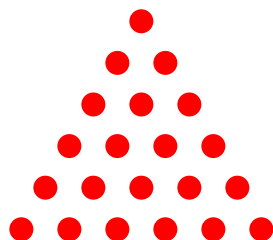

27.2 Special triangular numbers

Triangular numbers which are squares

The n -th triangular number $T_n = \frac{1}{2}n(n+1)$ is a square, say, m^2 if and only if

$$(2n+1)^2 - 2(2m)^2 = 1.$$

$$\begin{pmatrix} n_{k+1} \\ m_{k+1} \end{pmatrix} = \begin{pmatrix} 3 & 4 \\ 2 & 3 \end{pmatrix} \begin{pmatrix} n_k \\ m_k \end{pmatrix} + \begin{pmatrix} 1 \\ 1 \end{pmatrix}, \quad \begin{pmatrix} n_1 \\ m_1 \end{pmatrix} = \begin{pmatrix} 1 \\ 1 \end{pmatrix}.$$

Find the first few triangular numbers which are squares:

k	1	2	3	4	5	6	7
n_k	1	8	49				
m_k	1	6	35				
T_n	1	36	1225				

Palindromic triangular numbers

n	T_n	n	T_n	n	T_n
1	1	109	5995	3185	5073705
2	3	132	8778	3369	5676765
3	6	173	15051	3548	6295926
10	55	363	66066	8382	35133153
11	66	1111	617716	11088	61477416
18	171	1287	828828	18906	178727871
34	595	1593	1269621	57166	1634004361
36	666	1833	1680861	102849	5289009825
77	3003	2662	3544453	111111	6172882716

$$T_{11111111} = 61728399382716.$$

27.3 Pentagonal numbers

The pentagonal numbers are the sums of the arithmetic progression

$$1 + 4 + 7 + \cdots + (3n - 2) + \cdots$$

The n th pentagonal number is $P_n = \frac{1}{2}n(3n - 1)$.

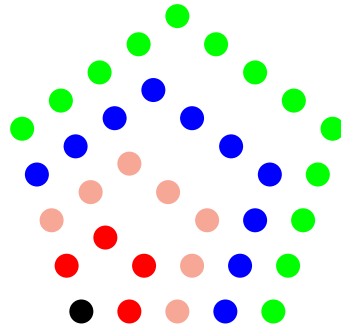

Palindromic pentagonal numbers

n	P_n	n	P_n	n	P_n
1	1	101	12521	6010	54177145
2	5	693	720027	26466	1050660501
4	22	2173	7081807	26906	1085885801
26	1001	2229	7451547	31926	1528888251
44	2882	4228	26811862	44059	2911771192

27.4 The polygonal numbers $P_{n,k}$

More generally, for a fixed k , the k -gonal numbers are the sums of the arithmetic progression

$$1 + (k - 1) + (2k - 3) + \cdots .$$

The n th k -gonal number is $P_{k,n} = \frac{1}{2}n((k - 2)n - (k - 4))$.

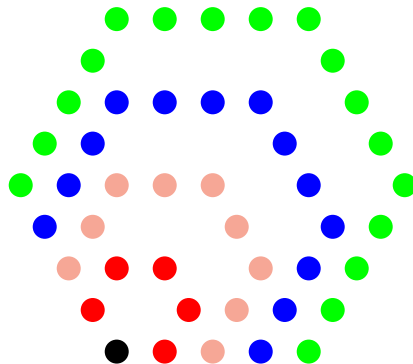

27.4.1 Appendix: Solution of Pell's equation

(1) Let d be a positive integer which is not a square. The positive integer solutions of the equation $x^2 - dy^2 = 1$ can be arranged in a sequence as follows. If $(x, y) = (a, b)$ is the smallest positive solution, then

$$\begin{pmatrix} x_{n+1} \\ y_{n+1} \end{pmatrix} = \begin{pmatrix} a & db \\ b & a \end{pmatrix} \begin{pmatrix} x_n \\ y_n \end{pmatrix}, \quad \begin{pmatrix} x_1 \\ y_1 \end{pmatrix} = \begin{pmatrix} a \\ b \end{pmatrix}.$$

(2) If the equation $x^2 - dy^2 = -1$ has a solution in nonzero integers, its integer solutions can be arranged in the form a sequence satisfying the same recurrence relation above (with (a, b) the smallest positive solution of $x^2 - dy^2 = 1$) but with (x_1, y_1) given by its smallest positive solution.

Exercise

1. Prove that every hexagonal number is a triangular number.
2. Find two triangular numbers (apart from 1) that are squares.
3. Find a pentagonal numbers (apart from 1) that is also a square.
4. It is known that there is only one value of n for which

$$1^2 + 2^2 + 3^2 + \cdots + n^2$$

is a square. What is this value?

5. Ramanujan's house number.
6. An unidentified country has 7-digit population – and everyone has been given a National ID Number, sequentially from one, allocated by no identifiable logic.

The Censure Minister has chosen three names at random, and is finding their ID number on the computer. When the first number appears on the screen, the Government's mathematical whiz-kid informs the Minister that there is precisely a 50-50 chance that the other two numbers will both be less than the one just displayed.

What is the population, and what is the first number? ¹

¹Problem 2585, *JRM*, 31 (2002–2003) 71.

Chapter 28

Polygonal triples

We consider polygonal numbers of a fixed shape. For a given positive integer k , the sequence of k -gonal numbers consists of the integers

$$P_{k,n} := \frac{1}{2} ((k-2)n^2 - (k-4)n). \quad (28.1)$$

By a k -gonal triple, we mean a triple of positive integers (a, b, c) satisfying

$$P_{k,a} + P_{k,b} = P_{k,c}. \quad (28.2)$$

A 4-gonal triple is simply a Pythagorean triple satisfying $a^2 + b^2 = c^2$. We shall assume that $k \neq 4$. By completing squares, we rewrite (28.2) as

$$\begin{aligned} & (2(k-2)a - (k-4))^2 + (2(k-2)b - (k-4))^2 \\ &= (2(k-2)c - (k-4))^2 + (k-4)^2, \end{aligned} \quad (28.3)$$

and note, by dividing throughout by $(k-4)^2$, that this determines a *rational* point on the surface \mathcal{S} :

$$x^2 + y^2 = z^2 + 1, \quad (28.4)$$

namely,

$$P(k; a, b, c) := (ga - 1, gb - 1, gc - 1), \quad (28.5)$$

where $g = \frac{2(k-2)}{k-4}$. This is always an integer point for $k = 3, 5, 6, 8$, with corresponding $g = -2, 6, 4, 3$. For $k = 3$ (triangular numbers), we shall change signs, and consider instead the point

$$P'(3; a, b, c) := (2a + 1, 2b + 1, 2c + 1). \quad (28.6)$$

The coordinates of $P'(3; a, b, c)$ are all odd integers exceeding 1.

28.1 Double ruling of \mathcal{S}

The surface \mathcal{S} , being the surface of revolution of a rectangular hyperbola about its conjugate axis, is a rectangular hyperboloid of one sheet. It has a double ruling, *i.e.*, through each point on the surface, there are two straight lines lying entirely on the surface.

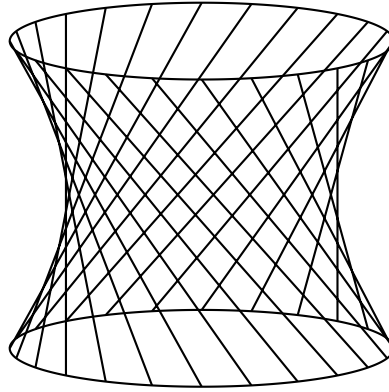

Figure 28.1:

Let $P(x_0, y_0, z_0)$ be a point on the surface \mathcal{S} . A line ℓ through P with direction numbers $p : q : r$ has parametrization

$$\ell : \quad x = x_0 + pt, \quad y = y_0 + qt, \quad z = z_0 + rt.$$

Substitution of these expressions into (28.4) shows that the line ℓ is entirely contained in the surface \mathcal{S} if and only if

$$px_0 + qy_0 = rz_0, \quad (28.7)$$

$$p^2 + q^2 = r^2. \quad (28.8)$$

It follows that

$$\begin{aligned} r^2 &= r^2(x_0^2 + y_0^2 - z_0^2) \\ &= r^2(x_0^2 + y_0^2) - (px_0 + qy_0)^2 \\ &= (p^2 + q^2)(x_0^2 + y_0^2) - (px_0 + qy_0)^2 \\ &= (qx_0 - py_0)^2. \end{aligned}$$

This means

$$qx_0 - py_0 = \epsilon r, \quad \epsilon = \pm 1. \quad (28.9)$$

Solving equations (28.7) and (28.9), we determine the direction numbers of the line. We summarize this in the following proposition.

Proposition 28.1. *The two lines lying entirely on the hyperboloid $\mathcal{S} : x^2 + y^2 = z^2 + 1$ and passing through $P(x_0, y_0, z_0)$ have direction numbers*

$$x_0 z_0 - \epsilon y_0 : y_0 z_0 + \epsilon x_0 : x_0^2 + y_0^2$$

for $\epsilon = \pm 1$.

In particular, if P is a rational point, these direction numbers are rational.

28.2 Primitive Pythagorean triple associated with a k -gonal triple

Let P be the rational point determined by a k -gonal triple (a, b, c) , as given by (28.5), for $k \geq 5$ and (28.6) for $k = 3$ (triangular numbers). We first note that the coordinates of P all exceed 1. This is clear for $k = 3$, and for $k \geq 5$, it follows from the fact that $g = \frac{2(k-2)}{k-4} > 2$. The direction numbers of the ruling lines on \mathcal{S} through the point P , as given in Proposition 1, are all positive. In view of (28.8), we may therefore choose a *primitive Pythagorean triple* (p, q, r) for these direction numbers. As is well known, every such triple is given by

$$p = m^2 - n^2, \quad q = 2mn, \quad r = m^2 + n^2 \quad (28.10)$$

for relatively prime integers $m > n$ of different parity.

We study the converse question of determining k -gonal triples from (primitive) Pythagorean triples.

28.3 Triples of triangular numbers

Given a primitive Pythagorean triple (p, q, r) as in (28.10), we want to determine a triangular triple (a, b, c) corresponding to it. Given an *odd* integer $z_0 > 1$, we obtain, from (28.7) and (28.9),

$$x_0 = \frac{pz_0 + \epsilon q}{r}, \quad y_0 = \frac{qz_0 - \epsilon p}{r}. \quad (28.11)$$

We claim that it is possible to choose $z_0 > 1$ so that x_0 and y_0 are also odd integers > 1 .

By the euclidean algorithm, there are *odd* integers u and v such that $qu + rv = 1$. (Note that v must be odd, since q is even. If u is even, we

replace (u, v) by $(u - r, v + q)$, in which both entries are odd). Clearly, the integer $z_0 = \epsilon pu$ is such that $qz_0 - \epsilon p = \epsilon p(qu - 1)$ is divisible by r . This makes y_0 an integer. The corresponding x_0 is also an integer. Replacing z_0 by $z_0 + rt$ for a positive integer t if necessary, the integers z_0 , x_0 , and y_0 can be chosen greater than 1. From (28.11), the integers x_0 and y_0 are both odd, since p and q are of different parity and z_0 is odd.

We summarize this in the following theorem.

Theorem 28.2. *Let (p, q, r) be a primitive Pythagorean triple. There are two infinite families of triangular triples $(a_\epsilon(t), b_\epsilon(t), c_\epsilon(t))$, $\epsilon = \pm 1$, such that one of the lines $\ell_\epsilon(P)$, $P = P'(3; a_\epsilon(t), b_\epsilon(t), c_\epsilon(t))$, has direction numbers $p : q : r$.*

Triangular triples from primitive Pythagorean triples

(m, n)	(p, q, r)	$(a_+(0), b_+(0), c_+(0))$	$(a_-(0), b_-(0), c_-(0))$
(2, 1)	(3, 4, 5)	(2, 2, 3)	(3, 5, 6)
(4, 1)	(15, 8, 17)	(9, 4, 10)	(5, 3, 6)
(3, 2)	(5, 12, 13)	(4, 9, 10)	(5, 14, 15)
(6, 1)	(35, 12, 37)	(20, 6, 21)	(14, 5, 15)
(5, 2)	(21, 20, 29)	(6, 5, 8)	(14, 14, 20)
(4, 3)	(7, 24, 25)	(6, 20, 21)	(7, 27, 28)
(8, 1)	(63, 16, 65)	(35, 8, 36)	(27, 7, 28)
(7, 2)	(45, 28, 53)	(35, 21, 41)	(9, 6, 11)
(5, 4)	(9, 40, 41)	(8, 35, 36)	(9, 44, 45)

28.4 k -gonal triples determined by a Pythagorean triple

Now, we consider $k \geq 5$. We shall adopt the notation

$$h' := \begin{cases} h & \text{if } h \text{ is odd,} \\ \frac{h}{2} & \text{if } h \text{ is even,} \end{cases}$$

for an integer h .

Theorem 28.3. *Let $k \geq 5$ and $g = \frac{2(k-4)}{k-2}$. The primitive Pythagorean triple (p, q, r) defined in (28.10) by relatively prime integers $m > n$ with different parity corresponds to a k -gonal triple if and only if one of $\frac{2n}{g}$ and $\frac{2(m-n)}{g}$ is an integer.*

Since m and n are relatively prime, the integer $(k-2)' > 1$ cannot divide both n and $m-n$. This means that a primitive Pythagorean triple

(p, q, r) corresponds to *at most one* line on \mathcal{S} associated with k -gonal triples (for $k \geq 5$).

Indeed, if $k = 4h + 2$, $(k - 2)'$ is the even number $2h$, and cannot divide the odd integer $m - n$. It follows that only those pairs (m, n) , with n a multiple of $2h$ give $(4h + 2)$ -gonal pairs. For example, by choosing $m = 2h + 1$, $n = 2h$, we have

$$\begin{aligned} p &= 4h + 1, & q &= 8h^2 + 4h, & r &= 8h^2 + 4h + 1, \\ a_0 &= 4h + 1, & b_0 &= 8h^2 + 2h + 1, & c_0 &= 8h^2 + 2h + 2. \end{aligned}$$

These give an infinite family of $(4h + 2)$ -gonal triples:

$$\begin{aligned} a_t &= (4h + 1)(t + 1), \\ b_t &= 8h^2 + 2h + 1 + (8h^2 + 4h)t, \\ c_t &= 8h^2 + 2h + 2 + (8h^2 + 4h + 1)t. \end{aligned}$$

$(4h + 2)$ – gonal triples

(h, k, g)	(m, n)	(p, q, r)	(a, b, c)
(1, 6, 4)	(3, 2)	(5, 12, 13)	(5, 11, 12)
	(5, 2)	(21, 20, 29)	(14, 13, 19)
	(5, 4)	(9, 40, 41)	(9, 38, 39)
	(7, 2)	(45, 28, 53)	(18, 11, 21)
	(7, 4)	(33, 56, 65)	(11, 18, 21)
	(7, 6)	(13, 84, 85)	(13, 81, 82)
	(9, 2)	(77, 36, 85)	(11, 5, 12)
	(9, 4)	(65, 72, 97)	(13, 14, 19)
	(9, 8)	(17, 144, 145)	(17, 140, 141)
	(11, 2)	(117, 44, 125)	(104, 39, 111)
	(11, 4)	(105, 88, 137)	(60, 50, 78)
	(11, 6)	(85, 132, 157)	(68, 105, 125)
	(11, 8)	(57, 176, 185)	(38, 116, 122)
	(11, 10)	(21, 220, 221)	(21, 215, 216)
(2, 10, $\frac{8}{3}$)	(5, 4)	(9, 40, 41)	(9, 37, 38)
	(7, 4)	(33, 56, 65)	(33, 55, 64)
	(9, 4)	(65, 72, 97)	(52, 57, 77)
	(9, 8)	(17, 144, 145)	(17, 138, 139)
	(11, 4)	(105, 88, 137)	(90, 75, 117)
	(11, 8)	(57, 176, 185)	(57, 174, 183)
(3, 14, $\frac{12}{5}$)	(7, 6)	(13, 84, 85)	(13, 79, 80)
	(11, 6)	(85, 132, 157)	(85, 131, 156)

28.5 Correspondence between $(2h + 1)$ -gonal and $4h$ -gonal triples

Let $k_1 < k_2$ be two positive integers ≥ 5 . Theorem 2 suggests that there is a one-to-one correspondence between k_1 -gonal triples and k_2 -gonal triples, provided $(k_1 - 2)' = (k_2 - 2)'$. This is the case if and only if

$$k_1 = 2h + 1, \quad k_2 = 4h, \quad \text{for some } h \geq 2. \quad (28.12)$$

In this case, $(k_1 - 2)' = (k_2 - 2)' = 2h - 1$, while $(k_1 - 4)' = 2h - 3$, and $(k_2 - 4)' = 2h - 2$. The $(2h + 1)$ -gonal triple (a, b, c) and a $4h$ -gonal triple (a', b', c') are related by

$$(m - n)(c - c') \equiv \frac{n}{2h - 1} \pmod{m^2 + n^2}.$$

$(2h + 1)$ - gonal and $4h$ - gonal triples

$(h, 2h + 1, 4h)$	(m, n)	(p, q, r)	$(2h + 1)$ - gonal (a, b, c)	$4h$ - gonal (a', b', c')
(2, 5, 8)	(4, 1)	(15, 8, 17)	(7, 4, 8)	(14, 8, 16)
	(4, 3)	(7, 24, 25)	(7, 23, 24)	(7, 22, 23)
	(5, 2)	(21, 20, 29)	(5, 5, 7)	(10, 10, 14)
	(7, 4)	(33, 56, 65)	(4, 7, 8)	(8, 14, 16)
	(7, 6)	(13, 84, 85)	(13, 82, 83)	(13, 80, 81)
	(8, 3)	(55, 48, 73)	(22, 19, 29)	(44, 38, 58)
	(8, 5)	(39, 80, 89)	(35, 72, 80)	(31, 64, 71)
	(10, 1)	(99, 20, 101)	(48, 10, 49)	(96, 20, 98)
	(10, 3)	(91, 60, 109)	(26, 17, 31)	(52, 34, 62)
	(10, 7)	(51, 140, 149)	(40, 110, 117)	(29, 80, 85)
	(10, 9)	(19, 180, 181)	(19, 177, 178)	(19, 174, 175)
(3, 7, 12)	(6, 1)	(35, 12, 37)	(16, 6, 17)	(33, 12, 35)
	(6, 5)	(11, 60, 61)	(11, 57, 58)	(11, 56, 57)
	(7, 2)	(45, 28, 53)	(33, 21, 39)	(44, 28, 52)
	(8, 3)	(55, 48, 73)	(27, 24, 36)	(36, 32, 48)
	(8, 5)	(39, 80, 89)	(39, 79, 88)	(26, 52, 58)
	(9, 4)	(65, 72, 97)	(24, 27, 36)	(32, 36, 48)
(4, 9, 16)	(8, 1)	(63, 16, 65)	(29, 8, 30)	(60, 16, 62)
	(8, 7)	(15, 112, 113)	(15, 107, 108)	(15, 106, 107)
	(9, 2)	(77, 36, 85)	(18, 9, 20)	(37, 18, 41)
	(10, 3)	(91, 60, 109)	(75, 50, 90)	(90, 60, 108)
	(10, 7)	(51, 140, 149)	(17, 45, 48)	(51, 138, 147)
(5, 11, 20)	(10, 1)	(99, 20, 101)	(46, 10, 47)	(95, 20, 97)
	(10, 9)	(19, 180, 181)	(19, 173, 174)	(19, 172, 173)

Chapter 29

Sums of consecutive squares

- 1 Sum of squares of natural numbers
- 2 Sums of consecutive squares: odd number case
- 3 Sums of consecutive squares: even number case

29.1 Sum of squares of natural numbers

Theorem 29.1.

$$1^2 + 2^2 + 3^2 + \cdots + n^2 = \frac{1}{6}n(n+1)(2n+1).$$

Proof. Let $T_n = 1 + 2 + 3 + \cdots + n = \frac{1}{2}n(n+1)$ and

$$S_n = 1^2 + 2^2 + 3^2 + \cdots + n^2.$$

$$\begin{array}{rcccccc} 2^3 & = & 1^3 & + & 3 \cdot 1^2 & + & 3 \cdot 1 & + & 1 \\ 3^3 & = & 2^3 & + & 3 \cdot 2^2 & + & 3 \cdot 2 & + & 1 \\ 4^3 & = & 3^3 & + & 3 \cdot 3^2 & + & 3 \cdot 3 & + & 1 \\ & & \vdots & & & & & & \\ n^3 & = & (n-1)^3 & + & 3(n-1)^2 & + & 3(n-1) & + & 1 \\ (n+1)^3 & = & n^3 & + & 3 \cdot n^2 & + & 3 \cdot n & + & 1 \end{array}$$

Combining these equations, we have

$$(n+1)^3 = 1^3 + 3S_n + 3T_n + n.$$

Since T_n is known, we have

$$S_n = \frac{1}{3} \left((n+1)^3 - n - 1 - \frac{3}{2}n(n+1) \right) = \frac{1}{6}n(n+1)(2n+1).$$

□

Exercise

1. Find $1^2 + 3^2 + 5^2 + \cdots + (2n-1)^2$.
2. Find n so that $n^2 + (n+1)^2$ is a square.

29.2 Sums of consecutive squares: odd number case

Suppose the sum of the squares of $2k + 1$ consecutive *positive* integers is a square. If the integers are $b, b \pm 1, \dots, b \pm k$. We require

$$(2k + 1)b^2 + \frac{1}{3}k(k + 1)(2k + 1) = a^2$$

for an integer a . From this we obtain the equation

$$a^2 - (2k + 1)b^2 = \frac{1}{3}k(k + 1)(2k + 1). \quad (E_k)$$

1. Suppose $2k + 1$ is a square. Show that (E_k) has solution only when $k = 6m(m + \epsilon)$ for some integers $m > 1$, and $\epsilon = \pm 1$. In each case, the number of solutions is *finite*.

Number of solutions of (E_k) when $2k + 1$ is a square

$2k + 1$	25	49	121	169	289	361	529	625	841	961	...
	0	1	1	2	7	3	5	3	3	10	...

2. Find the *unique* sequence of 49 (respectively 121) consecutive positive integers whose squares sum to a square.
3. Find the two sequences of 169 consecutive squares whose sums are squares.
4. Suppose $2k + 1$ is not a square. If $k + 1$ is divisible $9 = 3^2$ or by any prime of the form $4k + 3 \geq 7$, then the equation (E_k) has no solution. Verify that for the following values of $k < 50$, the equation (E_k) has no solution:

$$k = 6, 8, 10, 13, 17, 18, 20, 21, 22, 26, 27, 30, 32, \\ 34, 35, 37, 40, 41, 42, 44, 45, 46, 48, \dots$$

5. Suppose $p = 2k+1$ is a prime. If the Legendre symbol $\left(\frac{-\frac{1}{3}k(k+1)}{p}\right) = -1$, then the equation (E_k) has *no* solution. Verify that for the following values of $k < 50$, the equation (E_k) has no solution:

$$1, 2, 3, 8, 9, 14, 15, 20, 21, 26, 33, 39, 44.$$

6. For $k \leq 50$, it remains to consider (E_k) for the following values of k :

$$5, 7, 11, 16, 19, 23, 25, 28, 29, 31, 36, 38, 43, 47, 49.$$

Among these, only for $k = 5, 11, 16, 23, 29$ are the equations (E_k) solvable.

7. Work out 5 sequences of 23 consecutive integers whose squares add up to a square in each case.

Answer:

$$\begin{aligned} 7^2 + 8^2 + \dots + 29^2 &= 92^2; \\ 881^2 + 882^2 + \dots + 903^2 &= 4278^2; \\ 42787^2 + 42788^2 + \dots + 42809^2 &= 205252^2; \\ 2053401^2 + 2053402^2 + \dots + 2053423^2 &= 9847818^2; \\ &\dots \end{aligned}$$

8. Consider the equation $(E_{36}) : u^2 - 73v^2 = 12 \cdot 37 \cdot 73$. This equation does in fact have solutions $(u, v) = (4088, 478), (23360, 2734)$. The fundamental solution of the Pell equation $x^2 - 73y^2 = 1$ being $(a, b) = (2281249, 267000)$, we obtain two sequences of solutions of (E_{73}) :

Answer:

$$\begin{aligned} &(4088, 478), (18642443912, 2181933022), (85056113063608088, 9955065049008478), \dots \\ &(23360, 2734), (106578370640, 12474054766), (486263602888235360, 56912849921762734), \dots \end{aligned}$$

This means, for example, the sum of the squares of the 73 numbers with center 478 (respectively 2734) is equal to the square of 4088 (respectively 23360).

29.3 Sums of consecutive squares: even number case

Suppose the sum of the squares of the $2k$ consecutive numbers

$$b - k + 1, b - k + 2, \dots, b, \dots, b + k - 1, b + k,$$

is equal to a^2 . This means

$$(2a)^2 - 2k(2b + 1)^2 = \frac{2k}{3}(4k^2 - 1). \quad (E'_k)$$

Note that the numbers $2k, 4k^2 - 1$ are relatively prime.

1. Show that the equation (E'_k) has no solution if $2k$ is a square.
2. Suppose $2k$ is not a square. Show that if $2k + 1$ is divisible by 9, or by any prime of the form $4k + 1$, then the equation (E'_k) has no solution.
3. For $k \leq 50$, the equation (E'_k) has no solution for the following values of k :

$$k = 3, 4, 5, 9, 11, 13, 15, 17, 21, 23, 24, 27, 29, 31, 33, \\ 35, 38, 39, 40, 41, 45, 47, 49.$$

4. Let k be a prime. The equation (E'_k) can be written as

$$(2b + 1)^2 - 2ky^2 = -\frac{4k^2 - 1}{3}.$$

By considering Legendre symbols, the equation (E'_k) has no solution for the following values of $k \leq 50$:

$$k = 5, 7, 17, 19, 29, 31, 41, 43.$$

5. Excluding square values of $2k < 100$, the equation (E'_k) has solutions only for $k = 1, 12, 37, 44$.
6. Show that $(34, 0), (38, 3), (50, 7)$ are solutions of (E''_{12}) . Construct from them three infinite sequences of expressions of the sum of 24 consecutive squares as a square.

7. The equation (E'_{37}) has solutions $(185, 2)$, $(2257, 261)$, and $(2849, 330)$. From these we construct three infinite sequences of expressions of the sum of 74 consecutive squares as a square.

Answer:

$$\begin{aligned}225^2 + 226^2 + \cdots + 298^2 &= 2257^2; \\294^2 + 295^2 + \cdots + 367^2 &= 2849^2; \\13096^2 + 13097^2 + \cdots + 13179^2 &= 763865^2.\end{aligned}$$

8. The equation (E'_{44}) has solutions $(242, 4)$ and $(2222, 235)$. From these we obtain two infinite sequences of expressions of the sum of 88 consecutive squares as a square.

$$\begin{aligned}192^2 + 193^2 + \cdots + 279^2 &= 2222^2; \\5925^2 + 5926^2 + \cdots + 6012^2 &= 55990^2.\end{aligned}$$

Chapter 30

Sums of powers of natural numbers

Notation

$$S_k(n) := 1^k + 2^k + \cdots + n^k.$$

Theorem 30.1 (Bernoulli). $S_k(n)$ is a polynomial in n of degree $k + 1$ without constant term. It can be obtained recursively as

$$S_{k+1}(n) = \int (k + 1)S_k(n)dn + cn,$$

where c is determined by the condition that the sum of the coefficients is 1.

Examples

(1) $S_3(n) = 1^3 + 2^3 + \cdots + n^3 = \frac{1}{4}n^2(n + 1)^2$.

(2) Since $4S_3(n) = n^4 + 2n^3 + n^2$, we have

$$S_4(n) = \frac{1}{5}n^5 + \frac{1}{2}n^4 + \frac{1}{3}n^3 + cn,$$

where $c = 1 - \left(\frac{1}{5} + \frac{1}{2} + \frac{1}{3}\right) = \frac{-1}{30}$. Therefore,

$$1^4 + 2^4 + \cdots + n^4 = \frac{1}{5}n^5 + \frac{1}{2}n^4 + \frac{1}{3}n^3 - \frac{1}{30}n.$$

Exercise

1. Find the sum of the first n odd numbers.

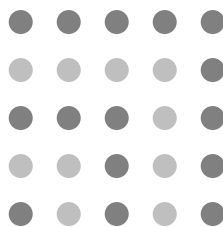

2. Find the sum of the cubes of the first n odd numbers.
3. Find $S_5(n)$ and $S_6(n)$.
4. Find the sum of the series

$$1 \cdot 2 \cdot 3 + 2 \cdot 3 \cdot 4 + 3 \cdot 4 \cdot 5 + \cdots + n(n+1)(n+2).$$

5. Find the sum of the first n triangular numbers.

Chapter 31

A high school mathematics contest

Christopher Newport University Regional High School Mathematics Contest, November, 2002¹

1. Randy and Hannah are eating at a restaurant. The items ordered by Randy cost twice as much as the items ordered by Hannah. Randy leaves a tip of 15% of the price of what he has ordered. Hannah leaves a tip of 20% of her items. The total, including tips, paid by the pair is exactly 70 dollars. How much was the cost of the items Hannah ordered?

¹*Crux Math.*, 29 (2003) 193–195.

2. Solve the equation

$$x^2 - |x| - 1 = 0.$$

3. Let (a_n) be an arithmetic sequence. If $a_p = q$ and $a_q = p$, find a_{p+q} .

4. A five-digit number is called a mountain number if the first three digits are increasing and the last three are decreasing. For example, 34541 is a mountain number, but 34534 is not. How many mountain numbers are greater than 70000?

5. Each day, Hai and Wai separately play a video game and compare scores. Hai's score on Tuesday was 10% less than his score on Monday, while Wai's score on Tuesday was 20 points higher than on Monday. However, on Wednesday, Hai's score was 10 points higher than on Tuesday, while Wai's score on Wednesday was 20% less than his score on Tuesday. Strangely, Hai's score plus Wai's score turned out to be the same on all three days. What were their scores on Wednesday?

6. A point P is given in the interior of a rectangle $ABCD$ with $AB = CD = 24$ and $AD = BC = 5$. What is the total area of the two triangles PAD and PBC (shaded in the figure)?

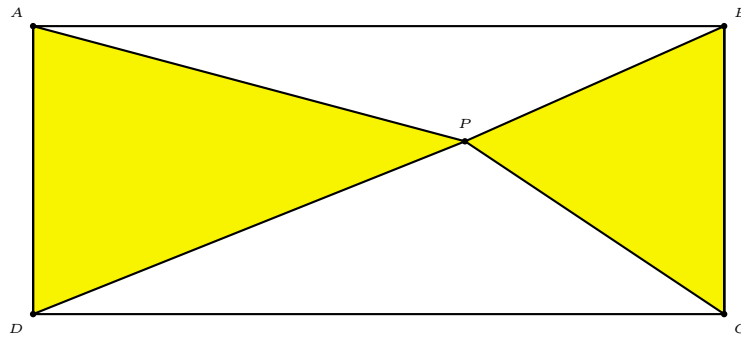

7. Samantha bought a stock for 1000 dollars whose price then doubled every year for the next n years. In the year after that, the stock price fell by 99%. Nevertheless, the stock was still worth more than 1000 dollars. What is the smallest whole number of years for which this is possible?

8. In triangle ABC , $\cos(A - B) + \sin(A + B) = 2$. Determine the shape of the triangle.

9. Four small circles of radius 1 are tangent to each other and to a larger circle containing them, as shown in the diagram. What is the area of the region inside the larger circle, but outside all the smaller circles?

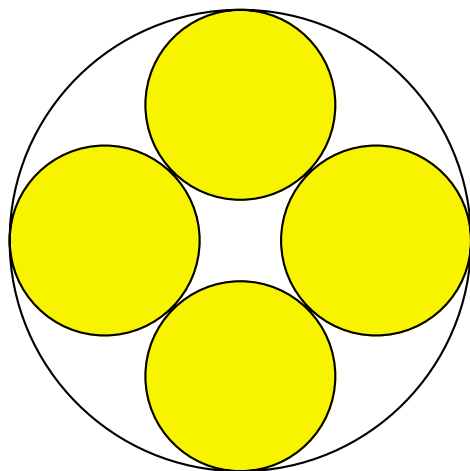

10. Two circles of radii 9 and 17 centimeters are enclosed in a rectangle with one side of length 50 centimeters. The two circles touch each other, and each touches two adjacent sides of the rectangle, as indicated. Find the area of the rectangle.

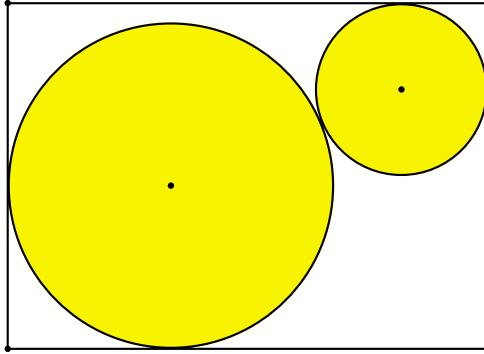

11. Find three different prime numbers a, b, c so that their sum $a + b + c$ and their product abc both end in the digit 7.
12. Karen ran a 42 kilometer marathon in 3 hours, 49 minutes. She did this by running for 10 minutes, walking for 2 minutes, then running for 10 minutes, walking for 2 minutes, and so on until she crossed the finish line. She runs twice as fast as she walks. What is her average speed, in kilometers per hour, while running?

Chapter 32

Mathematical entertainments

- 1 David Wells' survey of Beauty in Mathematics
- 2 T. M. Apostol's mathematical acrostic

32.1 Beauty in mathematics: David Wells' survey ¹

Give each of the following theorems a score for beauty between 0 (the least) and 10 (the most beautiful).

A		B		C		D		E	
F		G		H		I		J	
K		L		M		N		O	
P		Q		R		S		T	
U		V		W		X			

A Euler's formula for a polyhedron: $V - E + F = 2$.

B Any square matrix satisfies its own characteristic equation.

C If $p(n)$ is the number of partitions of n , then

$$\frac{5((1-x^2)(1-x^{10})(1-x^{15})\dots)^5}{((1-x)(1-x^2)(1-x^3)(1-x^4)\dots)^6}$$

$$= p(4) + p(9)x + p(14)x^2 + \dots$$

D The number of primes is infinite.

E There is no rational number whose square is 2.

F Every prime of the form $4n + 1$ is the sum of two integral squares in exactly one way.

G $1 + \frac{1}{2^2} + \frac{1}{3^2} + \dots + \frac{1}{n^2} + \dots = \frac{\pi^2}{6}$.

H $\frac{1}{2 \times 3 \times 4} - \frac{1}{4 \times 5 \times 6} + \frac{1}{6 \times 7 \times 8} - \dots = \frac{\pi-3}{4}$.

I π is transcendental.

J Every number greater than 77 is the sum of integers, the sum of whose reciprocal is 1.

K The maximum area of a quadrilateral with sides a, b, c, d is

$$\sqrt{(s-a)(s-b)(s-c)(s-d)},$$

where s is half the perimeter.

¹*Math. Intelligencer*, 10:4 (1988) 31.

- L** There is no equilateral triangle whose vertices are plane lattice points.
- M** At any party, there is a pair of people who have the same number of friends present.
- N** The number of partitions of an integer into odd integers is equal to the number of partitions into distinct integers.
- O** If the points of the plane are each colored red, yellow, or blue, there is a pair of points of the same color of mutual distance unity.
- P** Every plane map can be colored with 4 colors.
- Q** A continuous mapping of the closed unit disk into itself has a fixed point.
- R** Write down the multiples of $\sqrt{2}$, ignoring fractional parts, and underneath the number missing from the first sequence:
- | | | | | | | | | | |
|---|---|----|----|----|----|----|----|----|-----|
| 1 | 2 | 4 | 5 | 7 | 8 | 9 | 11 | 12 | ... |
| 3 | 6 | 10 | 13 | 17 | 20 | 23 | 27 | 30 | ... |
- The difference is $2n$ in the n -th place.
- S** A regular icosahedron inscribed in a regular octahedron divides the edges in the golden ratio.
- T** The number of representations of an odd number as the sum of 4 squares is 8 times the sum of its divisors; of an even number, 24 times the sum of its odd divisors.
- U** The word problem for groups is unsolvable.
- V** The order of a subgroup divides the order the group.
- W** $e^{i\pi} = -1$.
- X** There are 5 regular polyhedra.

32.2 T. M. Apostol's mathematical acrostic²

Guess as many WORDS as you can, then write each letter in the correspondingly numbered square in the diagram. When completely filled in, the diagram contains a passage from a published work concerning mathematics. The initial letters of the WORDS spell out the author and title of the work. All the WORDS are related to mathematics or mathematicians.

²*Math. Intelligencer*, 10:3 (1988) 43.

A	Unit of speed	$\overline{131}$	$\overline{9}$	$\overline{153}$	$\overline{62}$					
B	The second cervical vertebra	$\overline{87}$	$\overline{4}$	$\overline{177}$	$\overline{20}$					
C	In opposition	$\overline{160}$	$\overline{2}$	$\overline{84}$	$\overline{28}$	$\overline{145}$	$\overline{171}$	$\overline{104}$		
D	Countless	$\overline{61}$	$\overline{49}$	$\overline{110}$	$\overline{93}$	$\overline{63}$	$\overline{163}$	$\overline{42}$	$\overline{183}$	$\overline{115}$
E	Pallet of an escapement	$\overline{180}$	$\overline{3}$	$\overline{137}$	$\overline{90}$	$\overline{170}$				
F	Successive volumes (2 words)	$\overline{30}$	$\overline{159}$	$\overline{41}$	$\overline{86}$	$\overline{119}$	$\overline{75}$	$\overline{185}$		
G	Pupil of Gauss, last name followed by initials	$\overline{184}$	$\overline{45}$	$\overline{155}$	$\overline{27}$	$\overline{125}$	$\overline{70}$	$\overline{150}$	$\overline{43}$	
H	One way to describe Pythagoras	$\overline{15}$	$\overline{144}$	$\overline{121}$	$\overline{82}$	$\overline{33}$	$\overline{55}$			
I	Exact opposite	$\overline{52}$	$\overline{133}$	$\overline{12}$	$\overline{142}$	$\overline{25}$	$\overline{101}$	$\overline{76}$	$\overline{64}$	
J	Make a mosaic of	$\overline{148}$	$\overline{14}$	$\overline{21}$	$\overline{102}$	$\overline{32}$	$\overline{141}$	$\overline{85}$	$\overline{1}$	$\overline{182}$
K	First to prove e transcendental	$\overline{114}$	$\overline{67}$	$\overline{122}$	$\overline{10}$	$\overline{18}$	$\overline{139}$	$\overline{158}$		
L	Logical and sophistical reasoning	$\overline{108}$	$\overline{31}$	$\overline{176}$	$\overline{58}$	$\overline{100}$	$\overline{109}$	$\overline{34}$	$\overline{111}$	
M	A type of polynomial	$\overline{46}$	$\overline{81}$	$\overline{59}$	$\overline{138}$	$\overline{149}$				
N	Providing pleasure or delight	$\overline{22}$	$\overline{17}$	$\overline{35}$	$\overline{127}$	$\overline{147}$	$\overline{29}$	$\overline{50}$	$\overline{69}$	$\overline{97}$
O	Added	$\overline{154}$	$\overline{26}$	$\overline{7}$	$\overline{71}$	$\overline{164}$	$\overline{53}$			
P	Contour connecting points of equal depth below a water surface	$\overline{5}$	$\overline{92}$	$\overline{48}$	$\overline{60}$	$\overline{179}$	$\overline{89}$	$\overline{146}$		
Q	One of the first to use the method of successive approximations	$\overline{74}$	$\overline{11}$	$\overline{124}$	$\overline{103}$	$\overline{156}$				
R	Equal to the end proposed	$\overline{129}$	$\overline{169}$	$\overline{39}$	$\overline{136}$	$\overline{132}$	$\overline{120}$	$\overline{162}$	$\overline{72}$	$\overline{151}$
S	Three-digit code	$\overline{98}$	$\overline{44}$	$\overline{38}$	$\overline{130}$					
T	$M^2 = 0$ (two words)	$\overline{80}$	$\overline{106}$	$\overline{174}$	$\overline{168}$	$\overline{77}$	$\overline{56}$	$\overline{91}$	$\overline{167}$	$\overline{113}$
U	Distribution	$\overline{157}$	$\overline{23}$	$\overline{95}$	$\overline{57}$	$\overline{79}$	$\overline{126}$	$\overline{173}$	$\overline{88}$	
V	French mathematician (1765–1843)	$\overline{172}$	$\overline{112}$	$\overline{19}$	$\overline{40}$	$\overline{135}$	$\overline{96}$	$\overline{68}$		
W	Directed	$\overline{36}$	$\overline{51}$	$\overline{134}$	$\overline{78}$	$\overline{161}$	$\overline{123}$	$\overline{165}$		
X	Lowness in pitch	$\overline{83}$	$\overline{65}$	$\overline{140}$	$\overline{107}$	$\overline{54}$	$\overline{118}$	$\overline{173}$		
Y	One of Cayley's hyperdeterminants	$\overline{8}$	$\overline{152}$	$\overline{105}$	$\overline{16}$	$\overline{94}$	$\overline{166}$	$\overline{117}$	$\overline{73}$	$\overline{181}$
Z	German geometer (1833–1872)	$\overline{47}$	$\overline{99}$	$\overline{128}$	$\overline{37}$	$\overline{6}$	$\overline{178}$	$\overline{13}$		

	1	J	2	C		3	E	4	B	5	P	6	Z	7	O		8	Y	9	A				
10	K	11	Q	12	I	13	Z	14	J	15	H	16	Y	17	N	18	K	19	V	20	B		21	J
22	N	23	U	24	D		25	I	26	O	27	G	28	C	29	N	30	F	31	L	32	J		
33	H	34	L		35	N	36	W		37	Z	38	S		39	R	40	V	41	F	42	D		
	43	G	44	S	45	G	46	M		47	Z	48	P	49	D	50	N	51	W	52	I	53	O	
54	X	55	H	56	T	57	U	58	L	59	M		60	P	61	D	62	A		63	D	64	I	
65	X	66	N		67	K	68	V	69	N	70	G	71	O	72	R	73	Y	74	Q	75	F		
76	I	77	T	78	W	79	U		80	T	81	M	82	H		83	X	84	C	85	J	86	F	
87	B	88	U	89	P	90	E	91	T		92	P	93	D	94	Y	95	U	96	V	97	N	98	S
99	Z		100	L	101	I		102	J	103	Q	104	C	105	Y	106	T	107	X	108	L			
109	L	110	D		111	L	112	V	113	T	114	K	115	D	116	T	117	Y	118	X	119	F	120	R
121	H		122	K	123	W	124	Q	125	G	126	U	127	N	128	Z	129	R		130	S			
131	A	132	R	133	I	134	W		135	V	136	R		137	E	138	M	139	K	140	X	141	J	
142	I	143	R	144	H		145	C	146	P	147	N	148	J		149	M	150	G	151	R	152	Y	
153	A	154	O		155	G	156	Q		157	U	158	K	159	F	160	C	161	W	162	R	163	D	
164	O	165	W		166	Y	167	T		168	T	169	R	170	E	171	C	172	V	173	X			
174	T	175	U	176	L	177	B	178	Z	179	P	180	E		181	Y	182	J	183	D	184	G	185	F

Chapter 33

Maxima and minima without calculus

1. We have 1000 feet of fencing and wish to make with it a rectangular pen, at one side of a long wall. How can we arrange to surround the maximum area?

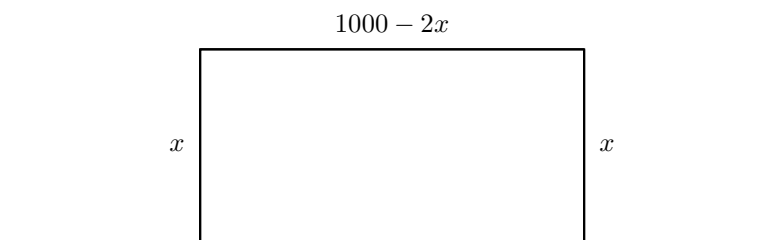

2. A Norman window has a fixed perimeter a . Find the largest possible area.

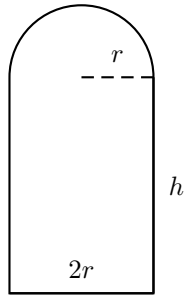

3. A right pyramid has a square base and a given surface area A . What is the largest possible volume?

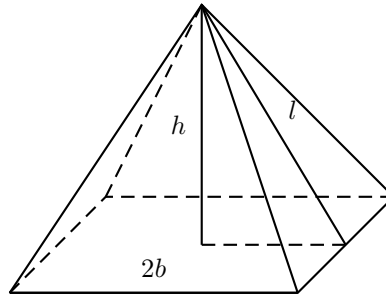

4. A tray is constructed from a square metal sheet by dimension $a \times a$ by cutting squares of the same size from the four corners and folding up the sides. What is the largest possible capacity of the tray?
5. The perimeter of a triangle is a constant $2s$. What is the largest possible area of the triangle?

6. The volume of a cylindrical can is given by $V = \pi r^2 l$ and the surface area by $A = 2\pi r(l + r)$. If the volume is a constant V , what is the least possible surface area?

7. Inscribe in a given cone a cylinder whose volume is largest possible.

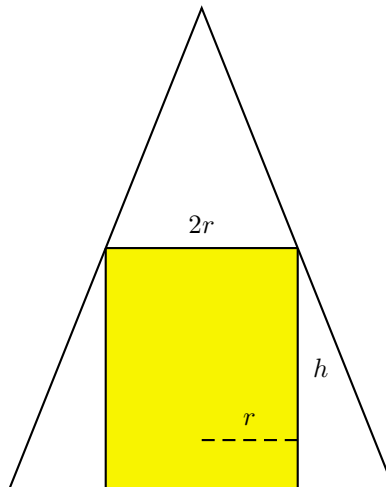

8. Find the largest cylinder contained in a sphere of radius R .

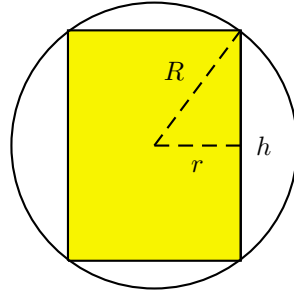

9. Find the largest right circular cone contained in a sphere of radius R .

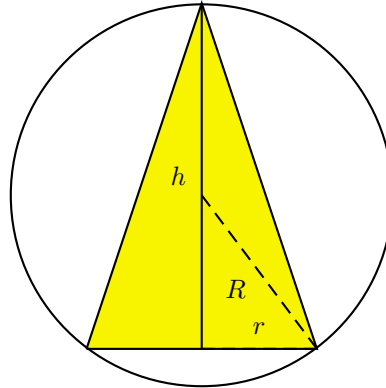

10. Two corridors of widths a and b meet at a right-angled corner. What is the length of the longest ladder which may be carried round the corner? Assume the workman sufficiently unimaginative to keep the ladder horizontal).

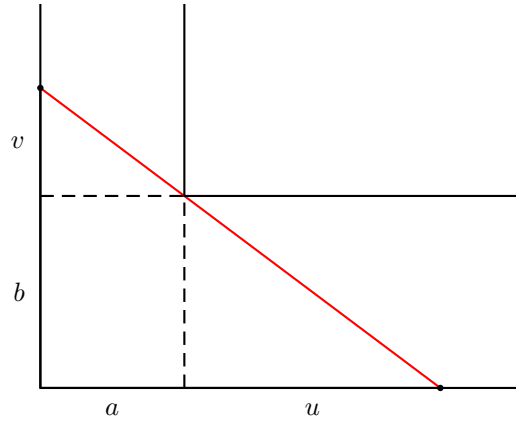

Chapter 34

A British test of teachers' mathematical background

Samples from a test on the mathematical background of (British) teachers in training in the late 1960's.¹

1. A necessary condition for the truth of a statement \mathcal{P} is that $\beta \geq 7$.

Which one of the following statement must be true?

- A If $\beta \geq 7$, \mathcal{P} is true.
- B If $\beta \geq 7$, \mathcal{P} is false.
- C If $\beta < 7$, \mathcal{P} is true.
- D If $\beta < 7$, \mathcal{P} is false.
- E None of these.

Answer: _____

2. A sufficient condition for the truth a statement \mathcal{Q} is that $\beta < 0$.

Which one of the following statements must be true?

- A If \mathcal{Q} is true, $\beta \geq 0$.
- B If \mathcal{Q} is false, $\beta \geq 0$.
- C If \mathcal{Q} is true, $\beta < 0$.
- D If \mathcal{Q} is false, $\beta < 0$.
- E None of these.

Answer: _____

¹*Math. Gazette*, 53 (1969) 357–362.

3. “**The** condition for a **quadrilateral** to be **cyclic** is that the opposite angles must be **supplementary**”.

Which of the words in **boldfont** should be altered?

- A The
- B quadrilateral
- C cyclic
- D supplementary
- E None of them

Answer: _____

4. What is the value of $\frac{x^2-9}{x-3}$ when $x = 3$?

- A 0
- B 1
- C 6
- D ∞
- E Do not know

Answer: _____

5. A certain theorem in Euclidean geometry has been proved.

Which of the following statements is necessarily true?

- A The converse is true and does not require proof.
- B The converse is true but requires proof.
- C The converse is false and does not require dis-proof.
- D The converse is false but requires dis-proof.
- E None of the above.

Answer: _____

6. It has been proved that an infinite number of triangles possess a property \mathcal{Q} .

Statement \mathcal{S} : All triangles possess property \mathcal{Q} .

Which of the following is necessarily correct?

- A \mathcal{S} is true, and no further proof is required.
- B \mathcal{S} is true, but proof is required.
- C \mathcal{S} is more likely to be true than false.
- D \mathcal{S} is more likely to be false than true.
- E None of the above.

Answer: _____

7. Consider the following calculation (all logarithms to base e):

$$\int_{-5}^{-3} \frac{dx}{x+1} = [\log(x+1)]_{-5}^{-3} \quad \text{(I)}$$

$$[\log(x+1)]_{-5}^{-3} = \log(-2) - \log(-4) \quad \text{(II)}$$

$$\log(-2) - \log(-4) = \log\left(\frac{-2}{-4}\right) \quad \text{(III)}$$

$$\log\left(\frac{-2}{-4}\right) = -\log 2 \quad \text{(IV)}$$

In which line, if any, does the **first** mistake in the calculation occur?

- A (I)
- B (II)
- C (III)
- D (IV)
- E None of these: it is correct.

Answer: _____

8. An algebraic problem involves a , b , c , and we have to write the sum of the products, two at a time.

With which of the following statements do you agree?

- A The best order is $ab + ac + bc$.
- B The best order is $ac + ba + cb$.
- C The best order is $bc + ca + ab$.
- D The best order is $cb + ab + ac$.
- E There is no "best" order.

Answer: _____

9. We wish to letter the points 1, 2, 3 in the diagram with the letter L , M , N in some order.

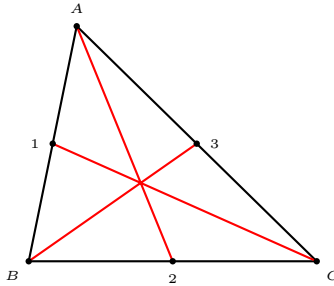

With which of the following statements do you agree?

- A The best order is $1L, 2M, 3N$.
- B The best order is $1M, 2N, 3L$.
- C The best order is $1N, 2L, 3M$.
- D The best order is $1L, 2N, 3M$.
- E There is no "best" order.

Answer: _____

Chapter 35

A mathematical contest

2001 Canadian Invitational Mathematics Challenge ¹

- 1 Thirty years ago, the ages of Xaviere, Yolanda, and Zoë were in the ratio 1:2:5. Today, the ratio of Xavior's age to Yolanda's age is 6:7. What is Zoë's present age?

¹Grades 10 and 11; *Crux Math.*, 29 (2003) 129–132.

2 Solve the system of equations

$$\begin{aligned}x + y + z &= 2, \\x^2 - y^2 + z^2 &= 2, \\x - 3y^2 + z &= 0.\end{aligned}$$

3(a) A flat mirror is perpendicular to the xy -plane and stands on the line $y = x + 4$. A laser beam from the origin strikes the mirror at $P(-1, 3)$ and is reflected to the point Q on the x -axis. Determine the coordinates of the point Q .

3(b) A flat mirror is perpendicular to the xy -plane and stands on a line \mathcal{L} . A laser beam from the origin strikes the mirror at $P(-1, 5)$ and is reflected to the point $Q(24, 0)$. Determine the equation of the line \mathcal{L} .

4 Determine all pairs of nonnegative integers (m, n) which are solutions to the equation $3(2^m) + 1 = n^2$.

5 Let $f(n) = n^4 + 2n^3 - n^2 + 2n + 1$.

(a) Show that $f(n)$ can be written as the product of two quadratic polynomials with integer coefficients.

(b) Determine all integers n for which $|f(n)|$ is a prime number.

Chapter 36

Some geometry problems from recent journals

- 1 Crux Mathematicorum
Jim Totten
Department of Mathematics and Statistics
University College of the Cariboo
Kamloops, BC, Canada, V2C 4Z9
- 2 Mathematics Magazine
Elgin Johnston, Problem Editor
Department of Mathematics
Iowa State University
Ames, IA 50011
- 3 American Mathematical Monthly
Doug Hensley, Monthly Problems
Department of Mathematics
Texas A&M University
3368 TAMU
College Station, TX 77843-3368
- 4 Pi Mu Epsilon Journal
Michael McConnell
840 Wood Street
Mathematics Department
Clarion University
Clarion, PA 16214

Crux 2813, proposed by Barry Monson, University of New Brunswick, Fredericton, NB and J. Chris Fisher, University of Regina, Regina, SK, Canada

Suppose that M is the midpoint of side AB of the square $ABCD$. Let P and Q be the points of intersections of the line MD with the circle, center M , radius $MA(= MB)$, where P is inside the square and Q is outside. Prove that the rectangle $APBQ$ is a golden rectangle, that is,

$$PB : PA = (\sqrt{5} + 1) : 2.$$

Crux 2822, proposed by Peter Woo, Biola University, La Mirada, CA

Suppose that Π is a parallelogram with sides of lengths $2a$ and $2b$ and with acute angle α , and that F and F' are the foci of the ellipse Λ that is tangent to the four sides of Π at their midpoints.

- (a) Find the major and minor semi-axes of Π in terms of a , b and α .
- (b) Find a straight-edge and compass construction for F and F' .

Crux 2823, proposed by Christopher J. Bradley, Clifton College, Britol, UK

Suppose that L, M, N are points on BC, CA, AB respectively, and are distinct from A, B, C . Suppose further that

$$\frac{BL}{LC} = \frac{1 - \lambda}{\lambda}, \quad \frac{CM}{MA} = \frac{1 - \mu}{\mu}, \quad \frac{AN}{NB} = \frac{1 - \nu}{\nu},$$

and that the circles AMN, BNL , and CLM meet at the Miquel point P . Find $[BCP] : [CAP] : [ABP]$ in terms of λ, μ, ν and the side lengths of triangle ABC .

Crux 2830, proposed by D. J. Smeenk, Zaltbommel, the Netherlands

Suppose that $\Gamma(O, R)$ is the circumcircle of triangle ABC . Suppose that side AB is fixed and that C varies on Γ (always on the same side of AB).

Suppose that I_a, I_b, I_c are the centers of the excircles of triangle ABC opposite A, B, C respectively. If Ω is the center of the circumcircle of triangle $I_a I_b I_c$, determine the locus of Ω as C varies.

Crux 2836, proposed by G. Tsintsifas, Thessaloniki, Greece

Suppose that triangle ABC is equilateral and that P is an interior point. The lines AP , BP , CP intersect the opposite sides at D , E , F respectively. Suppose that $PD = PE = PF$. Determine the locus of P .

Suppose P has homogeneous barycentric coordinates $(x : y : z)$ with respect to triangle ABC . Then, D divides BC in the ratio $BP : PC = z : y$, and $PD = \frac{x}{x+y+z} \cdot AD$. By Stewart's theorem,

$$AD^2 = \frac{z}{y+z}a^2 + \frac{y}{y+z}a^2 - \frac{yz}{(y+z)^2}a^2 = \frac{y^2 + yz + z^2}{(y+z)^2} \cdot a^2.$$

Therefore,

$$PD^2 = \frac{x^2(y^2 + yz + z^2)}{(x+y+z)^2(y+z)^2} \cdot a^2.$$

Similarly, we obtain

$$PE^2 = \frac{y^2(z^2 + zx + x^2)}{(x+y+z)^2(z+x)^2} \cdot a^2,$$

$$PF^2 = \frac{z^2(x^2 + xy + y^2)}{(x+y+z)^2(x+y)^2} \cdot a^2.$$

Therefore, $PE = PF$ if and only if

$$(x+y)^2y^2(z^2 + zx + x^2) = (z+x)^2z^2(x^2 + xy + y^2),$$

or

$$(y-z)(x+y+z)(x^3(y+z) + x^2(y^2 + yz + z^2) + xyz(y+z) + y^2z^2) = 0.$$

Since P is an interior point, x , y , z are positive. We conclude that $y = z$. Similarly, $PF = PD$ if and only if $z = x$.

The point P has coordinates $x : y : z = 1 : 1 : 1$; it is the center of the equilateral triangle.

Crux 2840, proposed by Juan-Bosco Romero Márquez, University of Valladolid, Valladolid, Spain

Let A' be an interior point of the line segment BC in triangle ABC . The interior bisectors of $\angle BA'A$ and $\angle CA'A$ intersect AB and CA at D and E respectively. Prove that AA' , BE , and CD are concurrent.

Crux 2847, proposed by G. Tsintsifas, Thessaloniki, Greece

The **incircle** inscribed in a tetrahedron is a circle of maximum radius inscribed in the tetrahedron, considering every possible orientations in \mathbb{E}^3 .

Find the radius of the **incircle** of a regular tetrahedron.

Crux 2849, proposed by Toshio Seimiya, Kawasaki, Japan

In a convex quadrilateral $ABCD$, we have $\angle ABC = \angle BCD = 120^\circ$. Suppose that $AB^2 + BC^2 + CD^2 = AD^2$. Prove that $ABCD$ has an inscribed circle.

Mathematics Magazine, Problem 1669, proposed by A. N. Duman, Bilkent University, Turkey

Let ABC be a triangle and let E be the midpoint of BC . A circle passing through A and C intersects BA and BC in points G and E respectively. Let D be the midpoint of EC . A line through D and perpendicular to BC intersects AC at F , with $3AF = FC$. Prove that triangle FDG is similar to triangle ABC .

Mathematics Magazine, Problem 1671, proposed by M. N. Deshpande, Institute of Science, Nagpur, India

Let \mathcal{T} be the set of triangles ABC for which there is a point D on BC such that segments AB , BD , AD , DC , and AC have integral lengths and $\angle ACD = \frac{1}{2}\angle ABC = \frac{1}{3}\angle ADB$.

- (a) Characterize the sets $\{a, b, c\}$ that are sets of side lengths of triangles in \mathcal{T} .
- (b) Find the triangle of minimum area in \mathcal{T} .

**American Mathematical Monthly, Problem 11006, proposed by B. Suceavă,
California State University, Fullerton, CA**

Let ABC be an acute triangle, T the midpoint of arc BC of the circle circumscribing ABC . Let G and K be the projections of A and T respectively on BC , let H and L be the projections of B and C on AT , and let E be the midpoint of AB . Prove that

- (a) $KH \parallel AC$, $GL \parallel BT$, $GH \parallel TC$, and $LK \parallel AB$.
- (b) G , H , K and L are concyclic.
- (c) The center of the circle through G , H , and K lies on the Euler circle (nine-point circle) of triangle ABC .

**Pi Mu Epsilon Journal, Problem 1058, proposed by P. A. Lindstrom,
Batavia, NY**

Suppose that triangle ABC has an interior point P . Let D, E, F be points on sides AB, BC, CA respectively, so that $PD \perp AB, PE \perp BC, PF \perp CA$. Let $|AB| = x, |BC| = y, |CA| = z, |AD| = a, |BE| = b,$ and $|CF| = c$.

1. Show that $(x - a)^2 + (y - b)^2 + (z - c)^2 = a^2 + b^2 + c^2$.
2. Show that if $\triangle ABC$ is an equilateral triangle, then $a + b + c = \frac{1}{2}(\text{perimeter})$ of triangle ABC .

**Pi Mu Epsilon Journal, Problem 1060, proposed by A. B. Ayoub,
Pennsylvania State University, Abington, College, Abington, PA**

Suppose $\triangle ABC$ is an equilateral triangle. The points D , E , and F are on AB , BC , CA respectively such that $|AD| = |BE| = |CF|$. Show that the circumcircles of triangles ABC and DEF are concentric.

Chapter 37

The Josephus problem and its generalization

37.1 The Josephus problem

n prisoners are arranged in a circle. In succession, every *second* one is removed from the circle and executed, and the last one is set free. Who is the survivor?

Examples

1. $n = 10$:

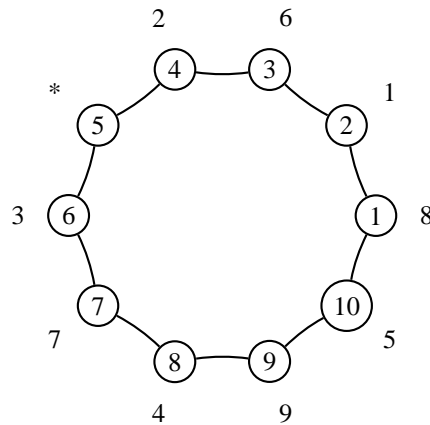

2. $n = 21$. After the removal of the 10 even numbered ones and then the first, there are the 10 odd numbers 3, 5, ..., 19, 21. The survivor is the 5-th of this list, which is 11.

Theorem 37.1. *Let $f(n)$ be the survivor in the Josephus problem of n prisoners.*

$$\begin{aligned}f(2n) &= 2f(n) - 1, \\f(2n + 1) &= 2f(n) + 1.\end{aligned}$$

Example

$$\begin{aligned}f(100) &= 2f(50) - 1 \\&= 2(2f(25) - 1) - 1 = 4f(25) - 3 \\&= 4(2f(12) + 1) - 3 = 8f(12) + 1 \\&= 8(2f(6) - 1) + 1 = 16f(6) - 7 \\&= 16(2f(3) - 1) - 7 = 32f(3) - 23 \\&= 32(2f(1) + 1) - 23 = 64f(1) + 9 \\&= 73.\end{aligned}$$

There is an almost explicit expression for $f(n)$: if 2^m is the largest power of $2 \leq n$, then

$$f(n) = 2(n - 2^m) + 1.$$

Corollary 37.2. *The binary expansion of $f(n)$ is obtained by transferring the leftmost digit 1 of n to the rightmost.*

$$f(100) = f(1100100_2) = 1001001_2 = 64 + 8 + 1 = 73.$$

37.2 Generalized Josephus problem $\mathcal{J}(n, k)$

$\mathcal{J}(10, 3)$:

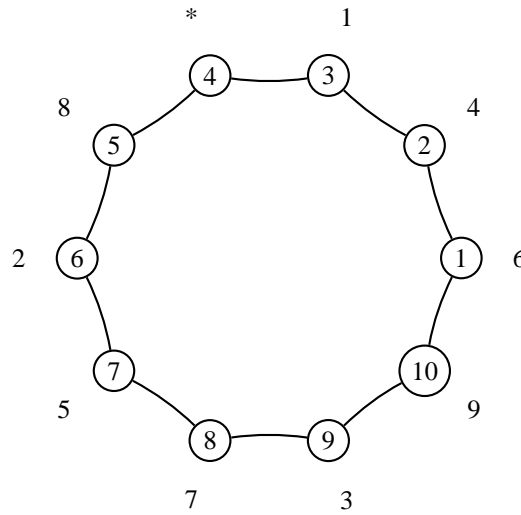

$\mathcal{J}(10, k)$ for various values of k

For $n = 10$, here are the sequences of execution depending on the values of k . The last column gives the survivors.

k										*
1	1	2	3	4	5	6	7	8	9	10
2	2	4	6	8	10	3	7	1	9	5
3	3	6	9	2	7	1	8	5	10	4
4	4	8	2	7	3	10	9	1	6	5
5	5	10	6	2	9	8	1	4	7	3
6	6	2	9	7	5	8	1	10	4	3
7	7	4	2	1	3	6	10	5	8	9
8	8	6	5	7	10	3	2	9	4	1
9	9	8	10	2	5	3	4	1	6	7
10	10	1	3	6	2	9	5	7	4	8

Positions 2 and 6 are *deadly* positions for the Josephus problem of 10 prisoners and random choice of k .

Exercise

1. For what values of n is $f(n) = n$?
2. For what values of n is $f(n) = n - 1$?
3. Make a list of the deadly positions of the Josephus problem for $n = 4, 5, \dots, 9$.
4. For $n = 7$, there is only one deadly position 1. This means that one other position is most likely to survive? Which one is it?
5. Find out the survivor in the Josephus problem $\mathcal{J}(24, 11)$.

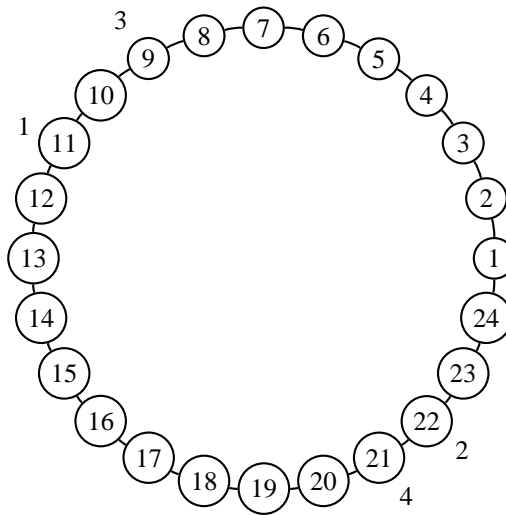

6. The deadly positions for $\mathcal{J}(24, k)$, $k = 1, \dots, 24$ are 5, 12, 13, 16, 18, 19, 22. What is the one with the best chance of survival?

Chapter 38

Permutations

38.1 The universal sequence of permutations

For convenient programming we seek an enumeration of the permutations. Regard each permutation of $1, 2, \dots, n$ as a bijection $\pi : \mathbb{N} \rightarrow \mathbb{N}$ which is “eventually” constant, *i.e.*, $f(m) = m$ for $m > n$. The enumeration begins with the identity permutation. The permutations of $1, 2, \dots, n$ are among the first $n!$ of them, and each of the first $(n - 1)!$ permutations ends with n .

Given an integer m , we write

$$m - 1 = r_2 \times 1! + r_3 \times 2! + \cdots + r_k \times (k - 1)!$$

for $0 \leq r_i < i$. These can be calculated recursively as follows. Beginning with $(q_1, r_1) = (m - 1, 0)$, we set, for each $i \geq 2$,

$$q_{i-1} = i \times q_i + r_i.$$

In other words,

$$(q_i, r_i) = \left(\left\lfloor \frac{q_{i-1}}{i} \right\rfloor, \text{mod}(q_{i-1}, i) \right).$$

Along with these, we construct a sequence of lists which ends at the desired permutation. Let $L_1 = (1)$. For $i \geq 2$, form L_i by inserting i into L_{i-1} so that there are exactly r_i members smaller than i on its right hand side. Then L_k is the permutation corresponding to m .

Example

To find the 12345th permutation, we write

$$12344 = 0 \times 1! + 1 \times 2! + 1 \times 3! + 4 \times 4! + 0 \times 5! + 3 \times 6! + 2 \times 7!.$$

The corresponding sequences are

k	L_k
1	(1)
2	(1, 2)
3	(1, 3, 2)
4	(1, 3, 4, 2)
5	(5, 1, 3, 4, 2)
6	(5, 1, 3, 4, 2, 6)
7	(5, 1, 3, 7, 4, 2, 6)
8	(5, 1, 3, 7, 4, 8, 2, 6)

The permutation is (5,1,3,7,4,8,2,6).

38.2 The position of a permutation in the universal sequence

Given a permutation L_n , we want to determine its position in the enumeration scheme above. For $j = n, n - 1, \dots, 2$, let

- (i) r_j be the number of elements in L_j on the right hand side of j ,
- (ii) L_{j-1} be the sequence L_j with j deleted.

Then, the position number of the permutation L_n is

$$1 + r_2 \times 1! + r_3 \times 2! + \dots + r_n \times (n - 1)!.$$

This number can be computed recursively as follows.

$$\begin{aligned} s_n &= r_n, \\ s_{n-1} &= s_n \times (n - 1) + r_{n-1}, \\ &\vdots \\ s_{j-1} &= s_j \times (j - 1) + r_{j-1}, \\ &\vdots \\ s_2 &= s_2 \times 2 + r_2, \\ s_1 &= s_2 \times 1 + 1. \end{aligned}$$

Example

Consider the permutation $L = (1, 4, 6, 2, 3, 7, 9, 8, 5)$.

j	L_j	r_j	s_j
9	(1, 4, 6, 2, 3, 7, 9, 8, 5)	2	2
8	(1, 4, 6, 2, 3, 7, 8, 5)	1	17
7	(1, 4, 6, 2, 3, 7, 5)	1	120
6	(1, 4, 6, 2, 3, 5)	3	723
5	(1, 4, 2, 3, 5)	0	3615
4	(1, 4, 2, 3)	2	14462
3	(1, 2, 3)	0	43386
2	(1, 2)	0	86772
1	(1)	1	86773

This permutation appears as the 86773-th in the universal sequence.

Exercise

1. Find the one-billionth permutation in the universal sequence.
2. The inverse permutation of $(5, 1, 3, 7, 4, 8, 2, 6)$ is $(2, 7, 3, 5, 1, 8, 4, 6)$. What is its position number in the universal sequence?
3. Let $(a_1, \dots, 1_n)$ be a permutation of $(1, 2, \dots, n)$.
 - (i) $\sum_{\text{cyclic}} |a_i - a_{i+1}| \geq 2n - 2$.
 - (ii) For how many distinct permutations of $(1, 2, \dots, n)$ does equality hold? Answer: $n \cdot 2^n$.

Project: Nice odd integers

An odd integer n is said to be nice if and only if there is a permutation (a_1, a_2, \dots, a_n) of $(1, 2, \dots, n)$ such that the sums

$$\begin{aligned} a_1 - a_2 + \cdots - a_{n-1} + a_n, \\ a_2 - a_3 + \cdots - a_n + a_1, \\ \vdots \\ a_n - a_1 + \cdots - a_{n-2} + a_{n-1} \end{aligned}$$

are all positive. Find all nice integers.

Chapter 39

Cycle decompositions

39.1 The disjoint cycle decomposition of a permutation

Theorem 39.1. *Every permutation can be decomposed into a product of disjoint cycles.*

For example, the permutation

$$\begin{pmatrix} 1 & 2 & 3 & 4 & 5 & 6 & 7 & 8 & 9 & X & J & Q & K \\ 6 & 9 & 8 & 3 & 4 & 2 & K & 7 & Q & 5 & 1 & J & X \end{pmatrix}$$

decomposes into the two disjoint cycles $(1629QJ)(387KX54)$.

Theorem 39.2. *Every cycle decomposes into a product of transpositions.*

Theorem 39.3. *A permutation can be decomposed into a product of transpositions. The parity (of the number of transpositions) of the permutation is independent of the decomposition.*

Thus, permutations are classified into even and odd permutations. Even (respectively odd) permutations are said to have parity $+1$ (respectively -1).

Corollary 39.4. *A cycle of length k has parity $(-1)^{k-1}$. More generally, a permutation of n objects has parity*

$$(-1)^{n - \text{number of disjoint cycles in a decomposition}}.$$

In using this formula, the fixed points are counted as 1-cycles, though we usually do not write them in the cycle decomposition of a permutation.

39.2 Dudeney's puzzle ¹

Take nine counters numbered 1 to 9, and place them in a row in the natural order. It is required in as few exchanges of pairs as possible to convert this into a square number. As an example in six moves we give the following: (7846932), which give the number 139854276, which is the square of 11826. But it can be done in much fewer moves.

The square of 12543 can be found in four moves, as follows.

	1	2	3	4	5	6	7	8	9
(25)	1	5	3	4	2	6	7	8	9
(37)	1	5	7	4	2	6	3	8	9
(38)	1	5	7	4	2	6	8	3	9
(34)	1	5	7	3	2	6	8	4	9

The squares of 25572, 26733, and 27273 can always be obtained in four moves.

•

	1	2	3	4	5	6	7	8	9
	6	5	3	9	2	7	1	8	4

•

	1	2	3	4	5	6	7	8	9
	7	1	4	6	5	3	2	8	9

•

	1	2	3	4	5	6	7	8	9
	7	4	3	8	1	6	5	2	9

¹Puzzle 128 of [Dudeney]

The pandigital case of Dudeney's puzzle

In the pandigital case, there are 4 ways to move

	1	2	3	4	5	6	7	8	9	0
(37)	1	2	7	4	5	6	3	8	9	0
(48)	1	2	7	8	5	6	3	4	9	0
(4X)	1	2	7	8	5	6	3	0	9	4
(49)	1	2	7	8	5	6	3	0	4	9

This gives the 1278563049, the square of 35757.

There are three other ways of making 4 moves to make a pandigital square. These are the squares of 35853, 38772, and 39147.

•

	1	2	3	4	5	6	7	8	9	0
	1	2	8	5	4	3	7	6	0	9

•

	1	2	3	4	5	6	7	8	9	0
	1	2	7	8	5	6	3	0	4	9

•

	1	2	3	4	5	6	7	8	9	0
	1	5	3	2	4	8	7	6	0	9

39.3 Dudeney's Canterbury puzzle 3

$$\boxed{7} \times \boxed{2} \boxed{8} = \boxed{1} \boxed{9} \boxed{6} = \boxed{3} \boxed{4} \times \boxed{5}.$$

While $7 \times 28 = 196$, it is not true that $34 \times 5 = 196$. Move as few counters as possible to make the equations valid. ²

(27)(495) 10 2 × 78 = = 156 = = 39 × 4.2

Project

The multiplication

$$\boxed{1}\boxed{2} \times \boxed{3}\boxed{4}\boxed{5} = \boxed{6}\boxed{7}\boxed{8}\boxed{9}$$

is clearly not valid. Move as few counters as possible to make the equation valid. ³

How about

$$\boxed{1}\boxed{2} \times \boxed{3}\boxed{4}\boxed{5} = \boxed{6}\boxed{7}\boxed{8}\boxed{9}\boxed{0}?$$

(348965) to 12 × 483 = 5796.³

39.4 The game of ropes and rungs

Each of the seven players starts by sliding down his own vertical rope, and makes a turn every time he encounters a rung. Who wins the prize *?

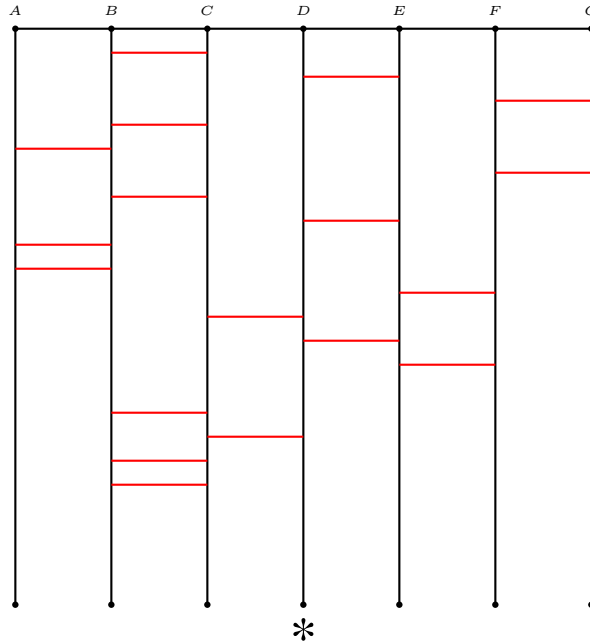

Suppose you are at position *A*, and are permitted to add any number of rungs in any positions, (provided that no two rungs are at the same horizontal level). How would you add rungs to claim the prize *?

Chapter 40

Graph labelling

40.1 Edge-magic triangle

Label the vertices and edges of a triangle with the numbers $1, 2, \dots, 6$ without repetition so that the sum of the three numbers along each edge is constant.

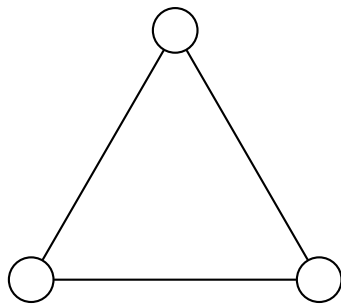

40.2 Face-magic tetrahedron

The vertices and edges of a tetrahedron with consecutive integers 1, 2, ..., 10 so that the four faces all have the same sum 32.

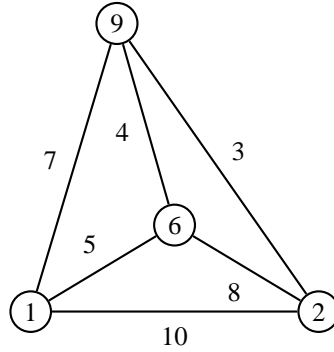

Can you label them with a smaller common face sum?

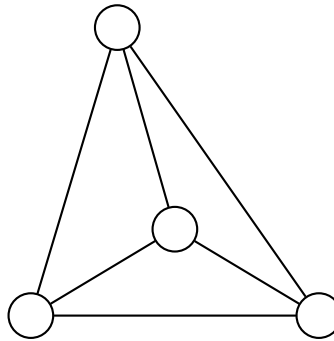

40.3 Magic cube

Label the vertices of a cube by the numbers 1, 2, ..., 8 without repetition such that the sum of the numbers at the four vertices of each face is a constant.

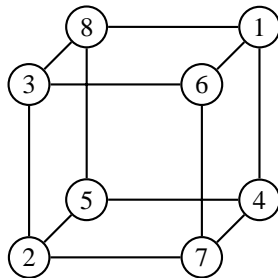
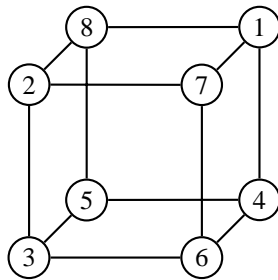
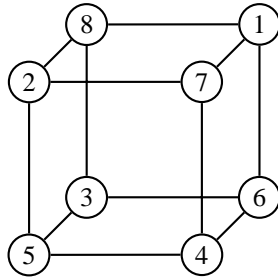

40.4 Edge-magic heptagon

Label the vertices and edges with the fourteen numbers $1, 2, \dots, 14$ (without repetition) so that the sum of the three numbers along each edge is constant.

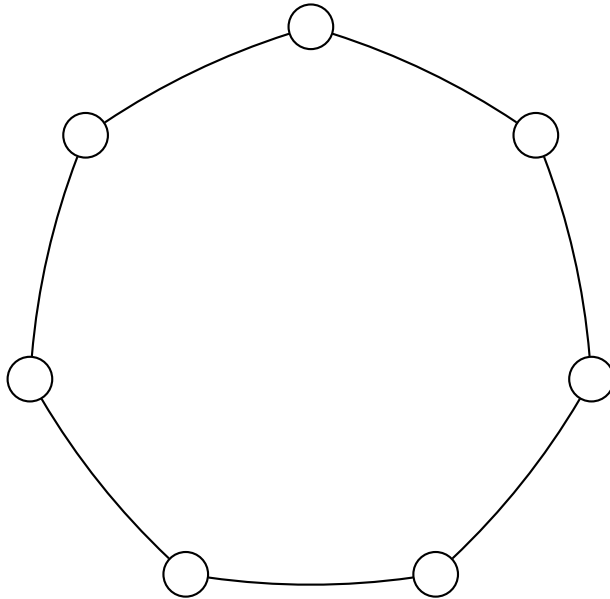

40.5 Edge-magic pentagram

It is known that the pentagram cannot be labelled with the numbers 1, 2, ..., 10 without repetition such that the sum of the four numbers along each line is constant.

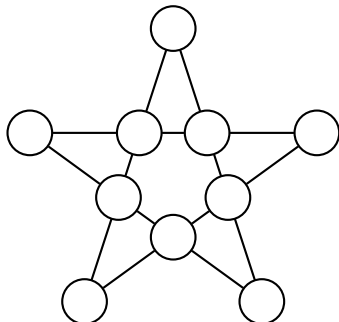

However, given the labelling of the five inner vertices below, it is possible to label the five outer vertices such that the sum of the four vertices along each of the five edges is constant. Find such a labelling with minimum edge sum.

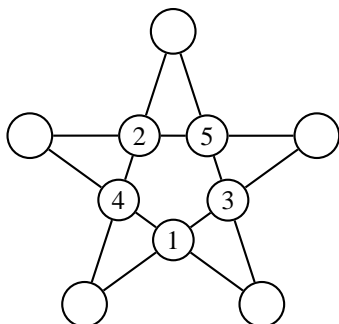

40.6 A perfect magic circle

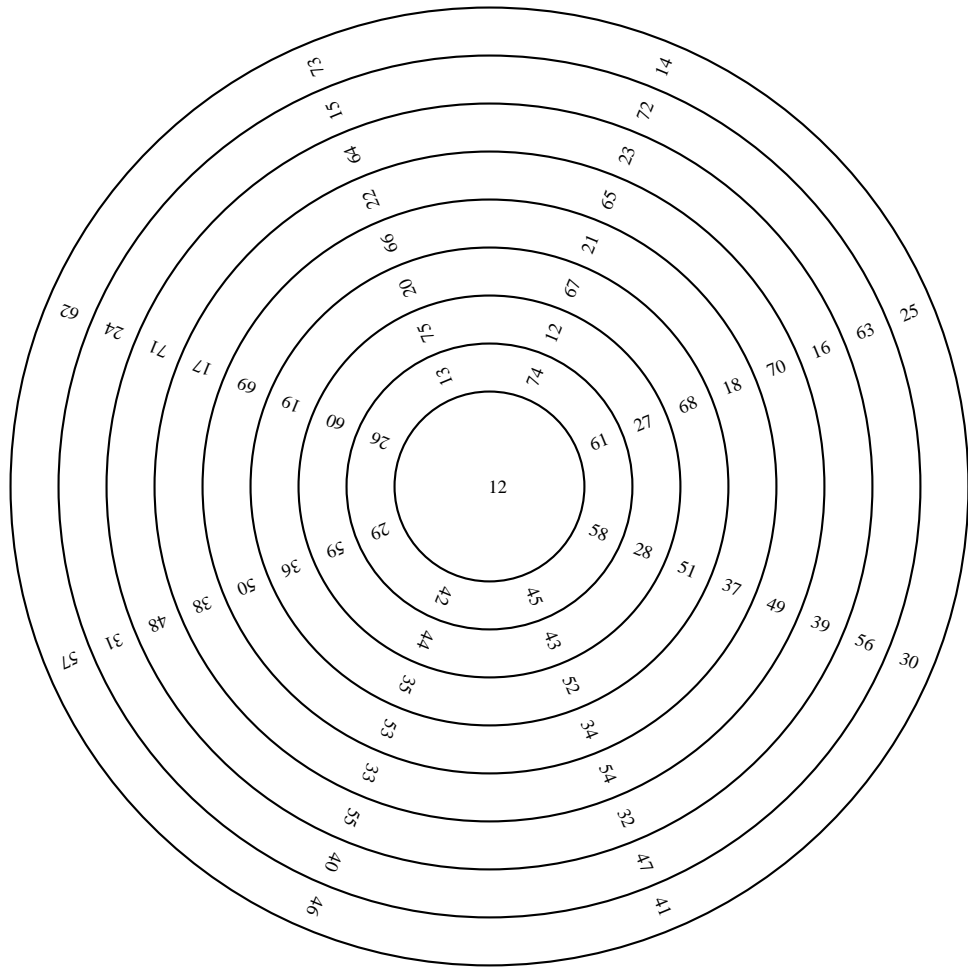

Chapter 41

Card tricks from permutations

Consider mn cards arranged in order, from left to right, and from top to bottom. We call this the standard order.

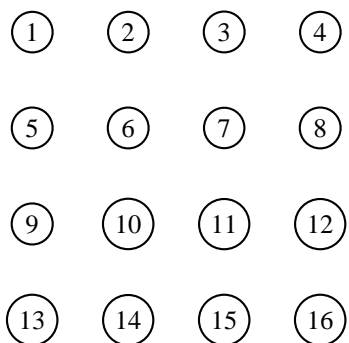

Rearrangements with simple cycle structure lead to interesting card puzzles. For example, the magician asks an audience to note the card at a specific spot, rearranges the cards according to some simple rule, then asks the audience to tell the new card at the spot. The magician is able to tell the card that originally occupies this position.

The rearrangement $\omega = \omega_{m,n}$

Pick up the cards along the columns, from top to bottom, and from left to right. Then rearrange them in the standard order.

For $m = n$, this rearrangement is the reflection in the main diagonal.

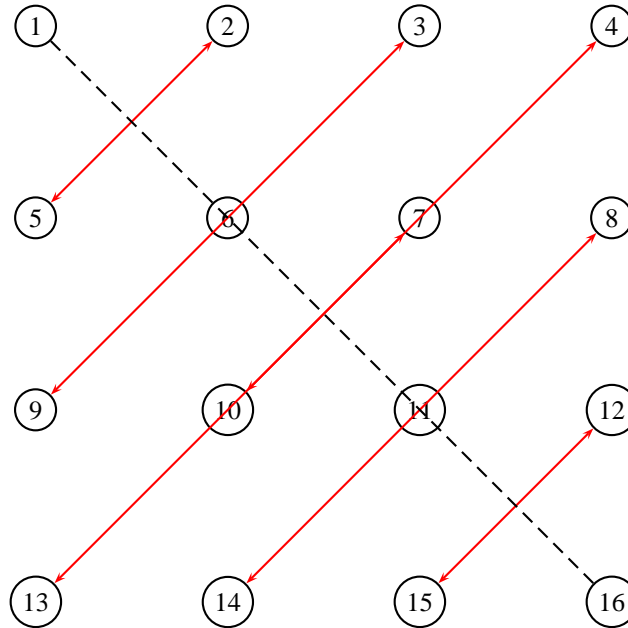

The rearrangement $\rho = \rho_{m,n}$

Pick up the cards along the columns, **from bottom to top**, and from left to right. Then rearrange them in the standard order.

For $m = n = 4$, this rearrangement is the cyclic permutation of the vertices of 4 squares:

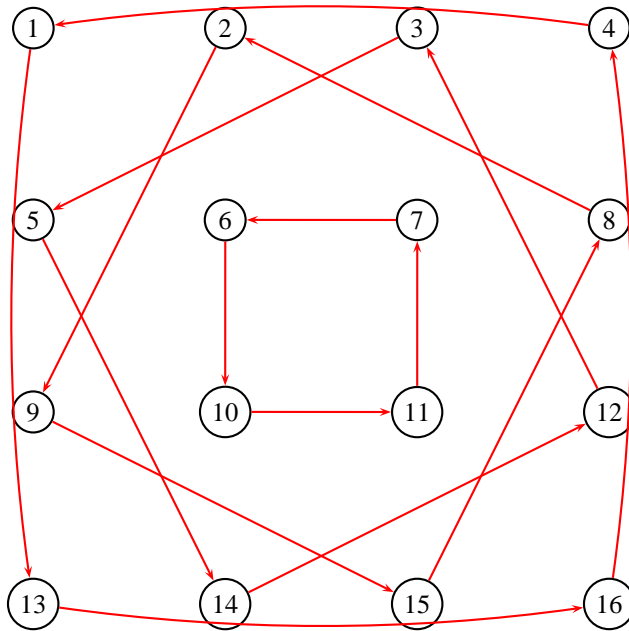

The cycle structure is simpler after one more application: it is simply rotation through 180° about the center of the square.

The repeated diagonal rearrangement

Pick up the cards along the **diagonals**, from **from bottom to top**, and from left to right. Then rearrange them in the standard order.

For $m = n = 4$, this is the permutation $\delta = \delta_{m,n}$

1	2	3	4	5	6	7	8	9	10	11	12	13	14	15	16
1	5	2	9	6	3	13	10	7	4	14	11	8	15	12	16

with cycle structure

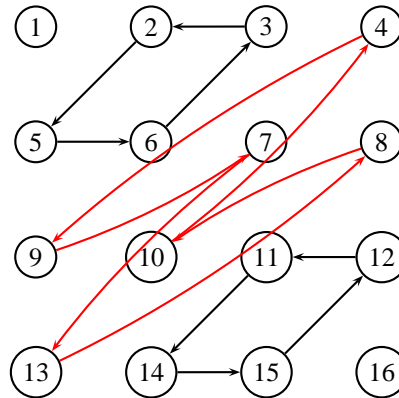

The cycle structure is simpler after one more application:

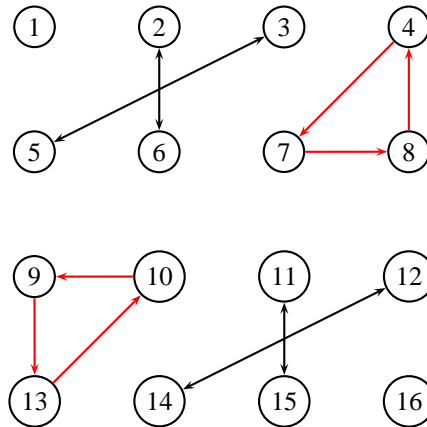

Chapter 42

Tetrahedra

42.1 The isosceles tetrahedron

An isosceles tetrahedron is one whose four faces are congruent triangles. Given a triangle ABC , construct its anticomplementary triangle $A'B'C'$ by drawing lines through the vertices parallel to their opposite sides. Fold along the sides of the given triangle to bring the vertices A' , B' , C' into a point D , forming an isosceles tetrahedron $ABCD$. Every isosceles tetrahedron arises from any one of its faces in this way. We may therefore ask for the volume of the isosceles tetrahedron $ABCD$ in terms of the side lengths of triangle ABC .

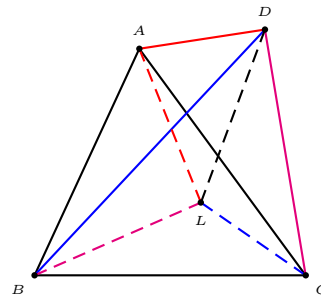
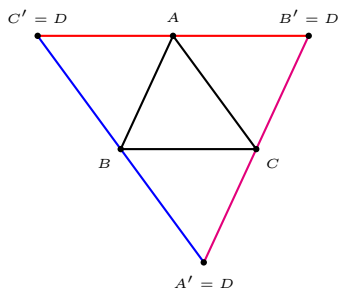

To compute the volume of a tetrahedron, we would drop the perpendicular from a vertex to its opposite face (of area Δ) to determine the height h on this face. The volume of the tetrahedron is then $V = \frac{1}{3}\Delta h$. For an isosceles tetrahedron, the position of this perpendicular foot is clearly the same for the four faces.

42.2 The volume of an isosceles tetrahedron

Let L be the pedal of the vertex D on the face ABC .¹ Consider the plane through D perpendicular to the faces ABC and DBC . This is the plane containing D , L , and the common pedal X of these points on the line BC . Upon unfolding the face DAB into triangle ABC' , triangle DZL becomes the segment $C'L$ intersecting AB at Z . Since $C'Z$ is perpendicular to AB , $C'L$ is perpendicular to $A'B'$. The same reasoning applied to the other two faces DBC and DCA shows that $A'L$, $B'L$, $C'L$ are perpendicular to $B'C'$, $C'A'$, $A'B'$ respectively. It follows that L is the orthocenter of triangle $A'B'C'$.

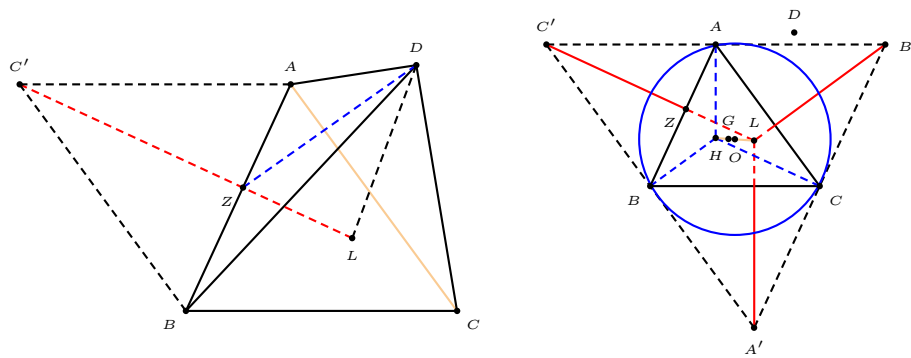

Proposition 42.1. *The point L is the reflection of H in O .*

The point L is called the de Longchamps point of triangle ABC .

Proposition 42.2.

$$OL^2 = OH^2 = R^2(1 - 8 \cos \alpha \cos \beta \cos \gamma).$$

Theorem 42.3. *The volume of the isosceles tetrahedron on triangle ABC is given by*

$$V_{\text{iso}} = \sqrt{\frac{1}{72}(b^2 + c^2 - a^2)(c^2 + a^2 - b^2)(a^2 + b^2 - c^2)}.$$

¹We use the word *pedal* for *perpendicular foot* or *orthogonal projection*.

42.3 Volume of a tetrahedron

Let $ABCD$ be a tetrahedron with

$$\begin{aligned} BC &= a, & CA &= b, & AB &= c, \\ AD &= a', & BD &= b', & CD &= c'. \end{aligned}$$

The volume V of the tetrahedron is given by

$$\begin{aligned} V^2 &= \frac{1}{288} \begin{vmatrix} 0 & 1 & 1 & 1 & 1 \\ 1 & 0 & a'^2 & b'^2 & c'^2 \\ 1 & a'^2 & 0 & c^2 & b^2 \\ 1 & b'^2 & c^2 & 0 & a^2 \\ 1 & c'^2 & b^2 & a^2 & 0 \end{vmatrix} \\ &= \frac{1}{144} \left(\left(\sum_{\text{edges}} a^2 \right) \left(\sum a^2 a'^2 \right) - 2 \sum a^2 a'^2 (a^2 + a'^2) - \sum_{\text{faces}} a^2 b^2 c^2 \right). \end{aligned}$$

42.4 Charles Twigg's envelope model of the tetrahedron

2

Take an sealed envelope which is two copies of a rectangle $ABCD$ glued along the perimeter. Assume $AB < BC$.

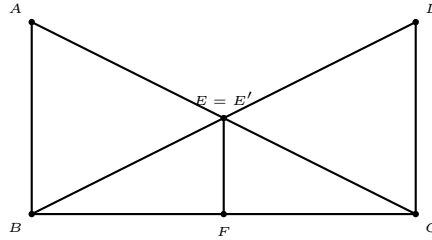

1. Fold the diagonals AC and BD . Their intersection is the double point E and E' .
2. Cut along two half diagonals AE and DE to remove the sector containing one long side and the flap of the envelope.
3. Fold along the remaining portions of the half diagonals (BE and CE) and crease firmly. Fold back along the same lines and crease firmly again.
4. Fold AB into DC to form the crease EF . Here, F is the midpoint of the side BC . Underneath E is the point E' .
5. Separate E and E' until EFE' is a straight line. Fold up around EFE' until D meets A , thus forming a hexahedron.
6. Tuck D under AB (or A under DC) and press up on B and C until DC and BA coincide.

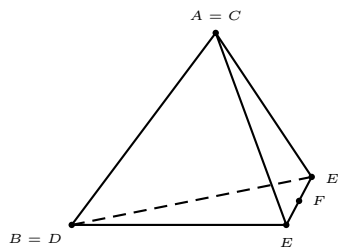

²C. W. Trigg, Tetrahedral models from envelopes, *Math. Mag.*, 51 (1978) 66–67.

Exercise

1. Find the volumes of the isosceles tetrahedra with face given below:

a	b	c	V
11	20	21	
33	65	72	
69	91	100	
21	99	100	

2. Find the volumes of the following tetrahedra:

a	b	c	a'	b'	c'	V
32	33	35	76	70	44	
21	32	47	58	76	56	

3. What is the shape of the envelope in Twigg's model for which the resulting tetrahedron is regular?
4. In Twigg's envelope model, suppose $AB = 2a$ and $BC = 2b$. What is the volume of the resulting tetrahedron? ³

³This is an isosceles tetrahedron with face $2a$, $\sqrt{a^2 + b^2}$, and $\sqrt{a^2 + b^2}$. Its volume is $\frac{4}{3}a^2\sqrt{b^2 - a^2}$.

Chapter 43

Lewis Carroll's unused geometry pillow problem

According to [Rowe], one of the pillow problems Lewis Carroll had attempted but did not include in his collection of pillow problems was the following.

Given a triangle ABC , to find, by paper folding, a line ℓ which intersects AC and AB at Y and Z respectively) such that if A' is the reflection of A in ℓ , then the reflections of B in $A'Z$ and of C in $A'Y$ coincide.

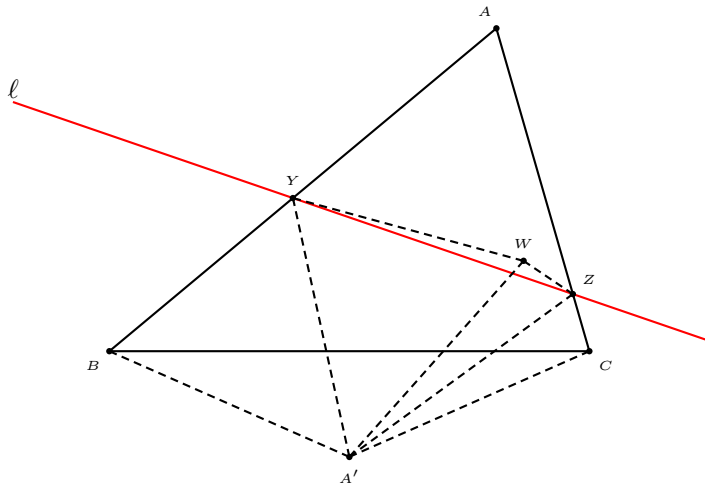

The point W is both the reflection of B in $A'Y$, and that of C in $A'Z$. It follows that $A'B = A'W = A'C$, and A' is on the perpendicular bisector of BC .

Consider the *directed* angle $\angle BA'C$. This is

$$\begin{aligned}\angle BA'C &= \angle BA'W + \angle WA'C \\ &= 2\angle YA'W + 2\angle WA'Z \\ &= 2\angle YA'Z \\ &= -2\angle YAZ\end{aligned}$$

since $A'YAZ$ is a rhombus. This means that $\angle BA'C = -2\angle BAC$. The reflection of A' in the side BC is therefore the point Q on the perpendicular bisector such that $\angle BQC = 2\angle BAC$, which is necessarily the circumcenter O of triangle ABC . We therefore conclude that A' is the reflection of the circumcenter O in the side BC , and the reflection line ℓ is the perpendicular bisector of the line AA' .

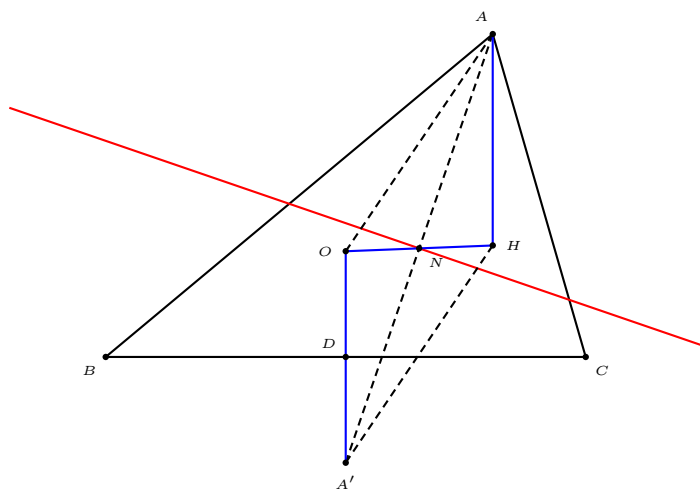

Let D be the midpoint BC and H the orthocenter of triangle ABC . In a standard proof of the Euler line theorem, it is established that $AH = 2OD$,¹ and that the midpoint of OH is the nine-point center of triangle ABC . This means that $AH = OA'$, and $AOA'H$ is a parallelogram. It follows that the midpoint of AA' is the same as that of OH , the nine-point center N of triangle ABC . *The Lewis Carroll paper-folding line is the perpendicular to AN at N .*

¹ $AH = 2 \cdot OD = 2R \cos A$, where R is the circumradius of triangle ABC .

Chapter 44

Japanese Temple Geometry

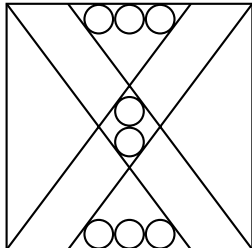
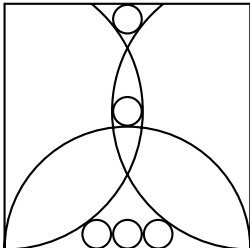
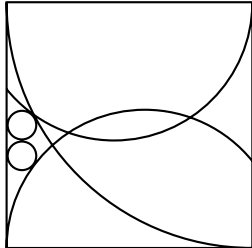
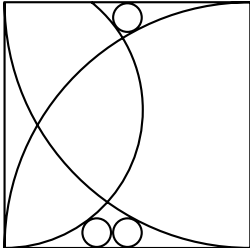

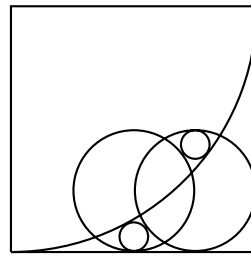
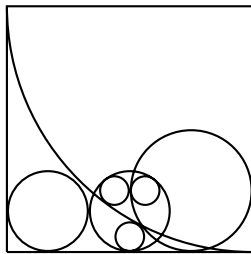
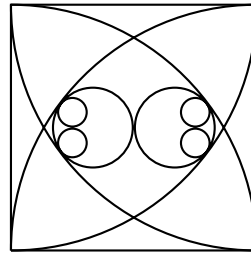
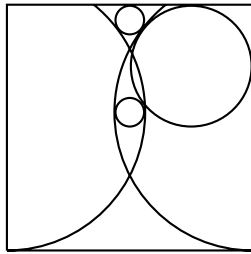
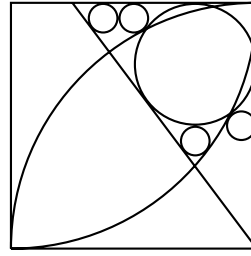
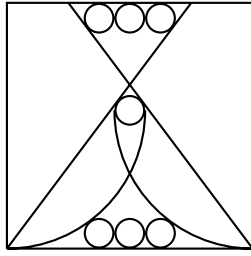

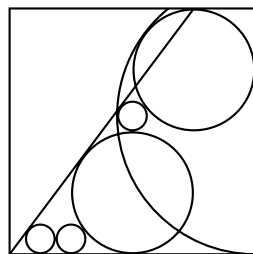
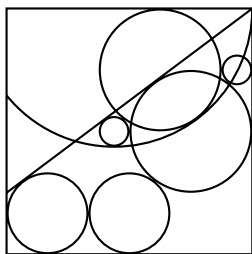
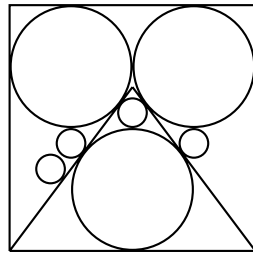
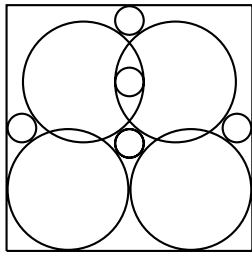
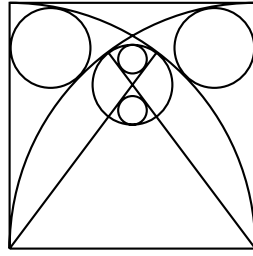
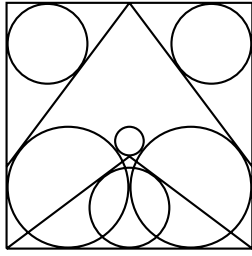

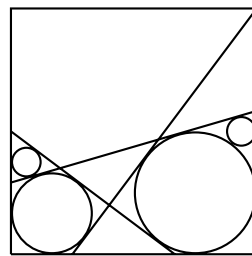
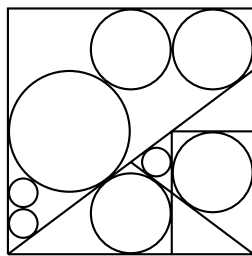
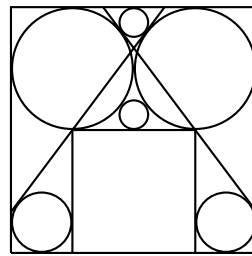
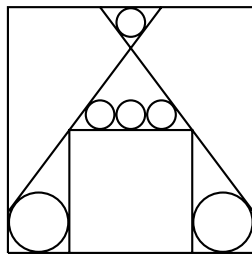
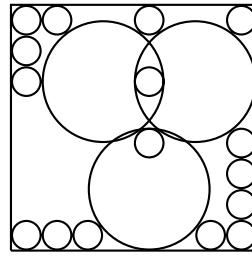
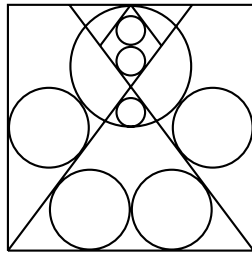

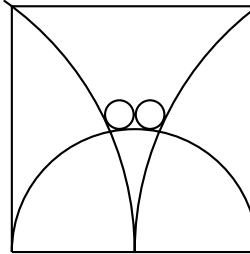
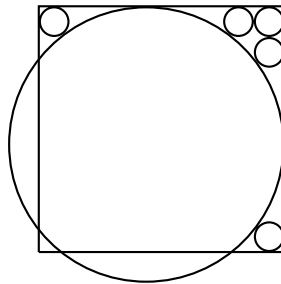
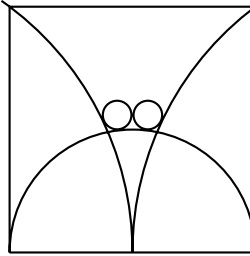
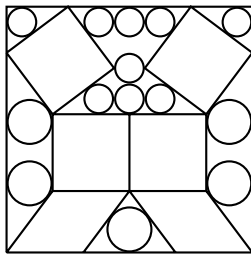
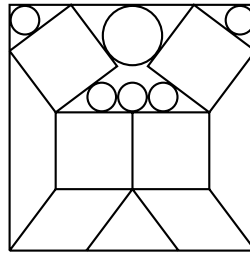
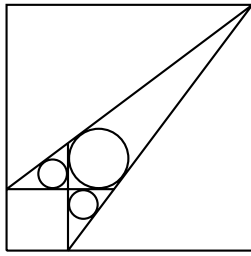

Bibliography

- [1] I. Adler, Make up your own card tricks, *Journal of Recreational Math.*, 6 (1973) 87–91.
- [2] I. Affleck and H. L. Abbott, Problem 1884, *Crux Math.*, 19 (1993) 264; solution, 20 (1994) 231–233.
- [3] M. Aigner and G. M. Ziegler, *Proofs from the BOOK*, Springer, 1998.
- [4] P. R. Allaire and A. Cupillari, Artemis Martin: An amateur mathematician of the nineteenth century and his contribution to mathematics, *College Math. Journal*, 31 (2000) 22–34.
- [5] G. E. Andrews, A note on partitions and triangles with integer sides, *American Math. Monthly*, 86 (1979) 477–478.
- [6] T. M. Apostol, A property of triangles inscribed in rectangles, *Crux Math.*, 3 (1977) 242–244.
- [7] Y. Arzoumanian and W. O. J. Moser, Enumerating 3-, 4-, 6-gons with vertices at lattice points, *Crux Math.*, 19 (1993) 249–254; 279–284.
- [8] D. F. Bailey, Counting arrangements of 1's and -1 's, *Math. Mag.*, 69 (1996) 128–131.
- [9] W. W. R. Ball and H. S. M. Coxeter, *Mathematical Recreations and Essays*, 13th edition, Dover, 1987.
- [10] S. Beatty et al., Problem 3177, *Amer. Math. Monthly*, 33 (1926) 159; solution, 34 (1927) 159–160.
- [11] A. Beiler, *Recreations in the Theory of Numbers*, Dover, 1963.

- [12] A. T. Benjamin and J. J. Quinn, Recounting Fibonacci and Lucas identities, *College Math. Journal*, 30 (1999) 359–366.
- [13] A. T. Benjamin and J. J. Quinn, *Proofs that Really Count: The Art of Combinatorial Proof*, Math. Assoc. Math., forthcoming.
- [14] A. T. Benjamin and J. J. Quinn, The Fibonacci numbers – e
- [15] A. Bliss et al., Four constants in four 4s, *Math. Mag.*, 74 (2001) 272.
- [16] A. Bourbeau, H. L. Nelson, et al., Problem 142, *Crux Math.*, 2 (1976) 93; solution, 175–178, 3 (1977) 106–108.
- [17] A. L. Bouton, *Annals of Math.*, ser. 2, 3 (1902) 33–59.
- [18] W. G. Brady and C. W. Twigg, Problem 232, *Pi Mu Epsilon Journal*, 5.2 (1969) 24; solution 5.3 (1970) 139.
- [19] I. Bruce, Another instance of the golden right triangle, *Fibonacci Quarterly*, 32 (1994) 232–233.
- [20] M. Buckheimer and A. Arcavi, Farey series and Pick’s area formula, *Math. Intelligencer*, 17:4 (1993) 64–67.
- [21] R. H. Buchholz and R. L. Rathbun, An infinite set of Heron triangles with two rational medians, *American Math. Monthly*, 104 (1997) 107–115.
- [22] P. R. Buckland, The mathematical background of teachers in training, *Math. Gazette*, 53 (1969) 357–362.
- [23] S. Bulman-Fleming and E. T. H. Wang, Problem 1143, *Crux Math.*, 12 (1986) 107; solution, 13 (1987) 237–238.
- [24] F. Burk, Natural logarithms via long division, *College Math. Journal*, 30 (1999) 309–310.
- [25] C. K. Caldwell, Truncatable primes, *Journal of Recreational Math.*, 19 (1987) 30–33.
- [26] C. K. Caldwell, Near repdigit primes, *Journal of Recreational Math.*, 21 (1988) 299–304; (1989) 101–109.
- [27] C. K. Caldwell and H. Dubner, *The near-repunit primes* $1_{n-k-1}0_11_k$, *Journal of Recreational Math.*, 27 (1995) 35–41.

- [28] C. K. Caldwell and H. Dubner, Unique-period primes, *Journal of Recreational Math.*, 29 (1998) 43–48.
- [29] L. Carroll, *Pillow Problems and A Tangled Tale*, 1895 and 1885, Dover reprint, 1958.
- [30] D. Cass and G. Wildenberg, A novel proof of the infinitude of primes, revisited, *Math. Mag.*, 76 (2003) 203.
- [31] P. L. Chessin and W. B. Carver, Problem E 1111, *American Math. Monthly*, 61 (1954) 258; solution 712.
- [32] A. J. Cole and A. J. T. Davie, A game based on the euclidean algorithm and a winning strategy for it, *Math. Gazette*, 53 (1969) 354–357.
- [33] D. B. Coleman, Sketch, a geoboard game, *Math. Mag.*, 51 (1978) 49–54.
- [34] J. H. Conway and R. K. Guy, *The Book of Numbers*, Springer, 1996.
- [35] R. J. Covill and T. O’Keeffe, Problem 679, *Journal of Recreational Math.*, 10 (1977–1978) 285; solution, 11 (1978–1979) 312.
- [36] H. S. M. Coxeter, The golden section, phyllotaxis, and Wythoff’s game, *Scripta Mathematica*, 19 (1953) 135–143.
- [37] K. David, Rencontres reencountered, *College Math. Journal*, 19 (1988) 139–148.
- [38] M. N. Desphande, An unexpected encounter with the Fibonacci numbers, *Fibonacci Quarterly*, 32 (1994) 108 – 109.
- [39] D. W. DeTemple, The triangle of smallest perimeter which circumscribes a semicircle, *Fibonacci Quarterly*, 30 (1992) 274.
- [40] C. Dodge, T. Schoch, P. Y. Woo, and P. Yiu, Those ubiquitous circles, *Math. Mag.*, 72 (1999) 202–213.
- [41] H. G. Dworschak and L. Sauv e, Problem 19, *Crux Math.*, 1 (1975) 8; solution, 1 (1975) 32–33.
- [42] H. Dubner, Recursive prime generating sequences, *Journal of Recreational Math.*, 29 (1998) 170–175.

- [43] H. E. Dudeney, *Amusements in Mathematics*, 1919, Dover reprint, 1958.
- [44] H. E. Dudeney, *536 Curious Problems and Puzzles*, edited by M. Gardner, Barnes and Noble reprint, 1995.
- [45] H. E. Dudeney, *Canterbury Puzzles*, 1919, Dover reprint, 2002.
- [46] U. Dudley, *Mathematical Cranks*, Math. Assoc. America, 1992.
- [47] H. G. Dworschak and L. Sauve, Problem 19, *Crux Math.*, 1 (1975) 8; solution 32.
- [48] E. J. Eckert, Primitive Pythagorean triples, *College Math. Journal*, 23 (1992) 413–417.
- [49] E. J. Eckert and H. Haagensen, A Pythagorean tiling of the plane, *Math. Mag.*, 62 (1989) 175.
- [50] R. E. Edwards et al., Problem 889, *Math. Mag.*, 47 (1974) 46–47; solution 289–292.
- [51] R. B. Ely, III, Magic designs, *Journal of Recreational Math.*, 1 (1968) 5–17.
- [52] A. Engel, *Problem Solving Strategies*, Springer, 1998.
- [53] R. Epp and T. Ferguson, A note on takeaway games, *Fibonacci Quarterly*, 18 (1980) 300–303.
- [54] P. Erdős and G. Szekeres, Some number theoretic problems on binomial coefficients, *Australian Math. Soc. Gazette*, 5 (1978) 97–99.
- [55] S. Forman, A serendipitous application of the Pythagorean triplets, *College Math. Journal*, 23 (1992) 312–314.
- [56] R. L. Francis, Mathematical haystacks: another look at repunit numbers, *College Math. Journal*, 19 (1988) 240–246.
- [57] A. S. Fraenkel and H. Herda, Never rush to be first in playing nimbi, *Math. Mag.*, 53 (1980) 21–26.
- [58] H. Fukagawa and D. Pedoe, *Japanese Temple Geometry*, Charles Babbage Research Centre, Winnipeg, 1989.

- [59] H. Fukagawa and J. F. Rigby, *Traditional Japanese Mathematical Problems*, 2002, SCT Publishing, Singapore.
- [60] H. Fürstenberg, On the infinitude of primes, *American Math. Monthly*, 62 (1955) 353.
- [61] J. Gallego-Diaz and D. L. Silverman, Problem 1453 (corrected), *American Math. Monthly*, 68 (1961) 177; correction, 572; solution 69 (1962) 166.
- [62] J. A. Gallian, The mathematics of identification numbers, *College Math. Journal*, 22 (1991) 194–202.
- [63] M. Gardner, Mathematical card tricks, *Scripta Math.*, 14 (1948) 99–111.
- [64] M. Gardner, *Hexaflexagons and Other Mathematical Diversions, The First Scientific American Book of Mathematical Puzzles and Diversions*, University of Chicago Press, 1988.
- [65] M. Gardner, *The Second Scientific American Book of Mathematical Puzzles and Diversions*, University of Chicago Press, 1987.
- [66] M. Gardner, *The Colossal Book of Mathematics*, Norton, 2001.
- [67] R. Gauntt and G. Rabson, The irrationality of $\sqrt{2}$, *American Math. Monthly*, 63 (1956) 247.
- [68] S. Golomb, Permutations by cutting and shuffling, *SIAM Review*, 3 (1961) 114–118.
- [69] S. Golomb, Iterated binomial coefficients, *American Math. Monthly*, 87 (1980) 719 - 727.
- [70] S. Golomb, Problem 477, *Pi Mu Epsilon Journal*, 7.3 (1980) 187; solution, 8.5 (1981) 348–349.
- [71] S. Golomb and M. S. Klamkin, Problem 232, *Pi Mu Epsilon Journal*, 5.2 (1970) 87; solution, 5.4 (1971) 208.
- [72] R. K. Guy, Problem 1153, *Crux Math.*, 12 (1986) 139; solution, 13 (1987) 286–287.
- [73] R. K. Guy, Problem 1220, *Crux Math.*, 13 (1987) 54; solution, 14 (1988) 125–126.

- [74] R. K. Guy, The strong law of small numbers, *Amer. Math. Monthly*, 95 (1988) 697–712.
- [75] R. K. Guy and M. E. Marcin, Problem 1915, *Crux Math.*, , 20 (1994) 48; solution, 21 (1995) 30.
- [76] R. K. Guy and C. Springer, Problem 1367, *Crux Math.*, 14 (1988) 202; solution, 15 (1989) 278–279.
- [77] R. K. Guy, The second strong law of small numbers, *Math. Mag.*, 63 (1990) 3–20.
- [78] R. K. Guy, *Unsolved Problems in Number Theory*, 2nd edition, Springer, 1994.
- [79] R. K. Guy and R. E. Woodrow, *The Lighter Side of Mathematics*, MAA, 1994.
- [80] A. Hall, Genealogy of Pythagorean triples, *Math. Gazette*, 54 (1970) 377–379.
- [81] G. H. Hardy, *A Mathematician's Apology*, Cambridge University Press, 1940.
- [82] G. H. Hardy, *A Course in Pure Mathematics*, 10th edition, 1952, Cambridge; reprint 1963.
- [83] A.P. Hatzipolakis and P. Yiu, The Lucas circles of a triangle, *Amer. Math. Monthly*, 108 (2001) 444 – 446.
- [84] O. Higgins, Another long string of primes, *Journal of Recreational Math.*, 14 (1981-82) 185.
- [85] A. M. Hinz, Pascal's triangle and the tower of Hanoi, *Amer. Math. Monthly*, 99 (1992) 538–544.
- [86] V. Hoggatt and L. Moser, Problem E 861, *American Math. Monthly*, 56 (1949) 262; solution 57 (1950) 35.
- [87] A. Holshouser and H. Reiter, One pile nim with arbitrary move function, *Electronic Journal of Combinatorics*, 10 (2003) #N7.
- [88] R. Honsberger, Semi-regular lattice polygons, *College Math. Journal*, 13 (1982) 36–44.

- [89] R. Honsberger, *In Pólya's Footsteps*, Math. Assoc. America, 1997.
- [90] A. F. Horadam, Fibonacci sequences and a geometric paradox, *Math. Mag.* 35 (1962) 1–11.
- [91] L. S. Johnson, Denumerability of the rational number system, *amm* 55 (1948) 65–70.
- [92] J. H. Jordan, R. Walsh, and R. J. Wisner, Triangles with integer sides, *American Math. Monthly*, 86 (1979) 686–688.
- [93] S. Kahan, s -transposable integers, *Math. Mag.*, 49 (1976) 27–28.
- [94] D. Kalman and R. Mena, The Fibonacci numbers – exposed, *Math. Mag.*, 76 (2003) 167–181.
- [95] C. Kicey and S. Goel, A series for $\ln k$, *American Math. Monthly*, 105 (1998).
- [96] M. S. Klamkin and P. Watson, Triangulations and Pick's theorem, *Math. Mag.*, 49 (1976) 35–37.
- [97] D. A. Klarner, *Mathematical Recreations, A Collection in Honor of Martin Gardner*, Dover, 1998, originally published as *Mathematical Gardner*, Wadsworth International, CA, 1981.
- [98] M. Kleber, The best card trick, *Math. Intelligencer*, 24 (2002) 1:9–11.
- [99] D. E. Knuth, *Fundamental Algorithms*, 2nd edition, Addison-Wesley, 1973.
- [100] T. Koshy, The digital root of a Fermat number, *Journal of Recreational Math.*, 31 (2002–2003) 112–113.
- [101] M. Kraitchik, *Mathematical Recreations*, 2nd edition, 1942; Dover reprint, 1953.
- [102] S. Kumar, On Fibonacci sequences and a geometric paradox, *Math. Mag.*, 37 (1964) 221–223.
- [103] V. S. Kumar, On the digital root series, *Journal of Recreational Math.*, 12 (1979–80) 267–270.

- [104] M. E. Larson, The eternal triangle – a history of a counting problem, *College Math. Journal*, 20 (1989) 370–384.
- [105] H. Larson and V. G. Feser, Problem 566, *Journal of Recreational Math.*, 9 (1976) 298; solution, 10 (1977–78) 311–313.
- [106] W. G. Leavitt, Repeating decimals, *College Math. Journal*, 15 (1984) 299–308.
- [107] D. N. Lehmer, Asymptotic evaluation of certain totient sums, *Amer. J. Math.* 22 (1900) 293–335.
- [108] R. B. Leigh and R. T. Ng, Minimizing aroma loss, *College Math. Journal*, 30 (1999) 356–358.
- [109] J. Lesko, A series for $\ln k$, *College Math. Journal*, 32 (2001) 119–122.
- [110] A. Liu, A direct proof of Pick’s theorem, *Crux Math.*, 4 (1978) 242–244.
- [111] E. Lucas, *Récreations Mathématiques*, 4 tomes, Gauthier Villars, Paris, 1891, 1896, 1893, 1894.
- [112] A. Machado, Nineteenth problems on elementary geometry, *Math. Intelligencer*, 17:1 (1995) 17–19.
- [113] G. Markowsky, Misconceptions about the golden ratio, *College Math. Journal*, 23 (1992) 2–19.
- [114] L. Marvin and F. H. Kierstead, Problem 315, *Journal of Recreational Math.*, 7 (1974) 62; solution 9 (1976–77) 307.
- [115] S. W. McInnis, Magic circles, *American Math. Monthly*, 60 (1953) 347–351.
- [116] R. K. Morley and P. Schub, Problem E24, *American Math. Monthly*, 40 (1933) 111; solution, 425–426.
- [117] S. B. Morris, Faro shuffling and card placement, *Journal of Recreational Math.*, 8 (1975) 1–7.
- [118] S. B. Morris, The basic mathematics of the faro shuffle, *Pu Mu Epsilon Journal*, 6.2 (1975) 85–92.

- [119] W. Moser, It is elementary (combinatorics), *Crux Math.*, 18 (1992) 257–262; 289–295; 19 (1993) 1–2.
- [120] D. Nelson, A regular pentagon construction, *Math. Gazette*, 61 (1977) 215–216.
- [121] I. Niven, Note on a paper by L. S. Johnson, *Amer. Math. Monthly*, 55 (1948) 358.
- [122] L. C. Noll and D. I. Bell, n -clusters for $1 < n < 7$, *Mathematics of Computation*, 53 (1989) 439–444.
- [123] A. Porges, A set of Eight Numbers, *American Math. Monthly*, 52 (1945) 379 - 384.
- [124] A. S. Posamentier and C. T. Salkind, *Challenging Problems in Geometry*, Dover, 1988.
- [125] C. S. Queen, Palindromes, *Fibonacci Quarterly*, 31 (1993) 216–226.
- [126] S. Rabinowitz, Problem 1299, *Journal of Recreational Math.*, 16 (1983–1984) 139.
- [127] Note on magic circles, *American Math. Monthly*, 60 (1953) 640.
- [128] V. Revennaugh and R. W. Buckley, Problem 385, *Journal of Recreational Math.*, 8 (1975–76) 137; solution, 10 (1977–78) 288–289.
- [129] P. Ribenboim, *The New Book of Prime Number Records*, Springer, 1996.
- [130] J. Roberts, *Elementary Number Theory, A Problem Oriented Approach*, MIT, 1975.
- [131] R. R. Rowe, Carroll's paper folding pillow problem, *Journal of Recreational Math.*, 4 (1971) 192–198.
- [132] D. L. Silverman, R. R. Robinson and R. L. Patton, Problems 141, 142, *Journal of Recreational Math.*, 3 (1970) 237; solution, 4 (1971) 222–223.
- [133] F. Rubin and V. G. Feser, Problem 1078, *Journal of Recreational Math.*, 14 (1981) 141–142; solution, 15 (1982–1983) 155–156.

- [134] N. Sato, An ambivalent sum, *Crux Math.*, 23 (1997) 290–293.
- [135] D. Schattschneider, Counting it twice, *College Math. Journal*, 22 (1991) 203–211.
- [136] J. Schram, A string of 176 primes, *Journal of Recreational Math.*, 15 (1982–83) 168–169.
- [137] J. Schram, A recurrence relation for Fermat numbers, *Journal of Recreational Math.*, 16 (1983–84) 195–197.
- [138] A. J. Schwenk, Take-away games, *Fibonacci Quarterly*, 8 (1970) 225–234.
- [139] H. Shapiro, An arithmetic function arising from the ϕ function, *Amer. Math. Monthly*, 50 (1943) 18–30.
- [140] D. L. Silverman and D. Singmaster, Problem 1017, *Journal of Recreational Math.*, 13 (1980) 298; solution, 14 (1981–1982) 313.
- [141] D. Singmaster, Problem 267, *Journal of Recreational Math.*, 6 (1973) 152–153.
- [142] D. Singmaster and B. Barwell, Problem 812, *Journal of Recreational Math.*, 13 (1980–1981) 62–63.
- [143] D. Singmaster, Triangles with integer sides and sharing barrels, *College Math. Journal*, 21 (1990) 278–285.
- [144] J. Slocum, *The Tangram Book*, Sterling, New York, 2003.
- [145] C. A. B. Smith, Compound games with counters, *Journal of Recreational Math.*, 1 (1968) 67–77.
- [146] M. Somos and R. Haas, A linked pair of sequences implies the primes are infinite, *American Math. Monthly*, 110 (2003) 539–540.
- [147] J. A. Spencer and H. Ahlburg, Problem 428, *Crux Math.*, 5 (1979) 77; solution, 6 (1980) 50.
- [148] J. E. Trevor and W. E. Buker, Problem 178, *American Math. Monthly*, 43 (1937) 104; solution, 499–500.
- [149] C. W. Trigg, Eight digits on a cube's vertices, *Journal of Recreational Math.*, 7 (1974) 49–55.

- [150] C. W. Trigg, Tetrahedral models from envelopes, *Math. Mag.*, 51 (1978) 66–67.
- [151] C. W. Trigg, Some curiosa involving the first ten perfect numbers, *Journal of Recreational Math.*, 23 (1991) 286.
- [152] T. Trotter, Perimeter-magic polygons, *Journal of Recreational Math.*, 7 (1974) 14–20.
- [153] M. Wald, Solution to Problem 1664, *Journal of Recreational Math.*, 21 (1989) 236–237.
- [154] F. T. Wang and C. C. Hsiung, A theorem on the tangram, *American Math. Monthly*, 49 (1942) 596–599.
- [155] S. R. Wassel, Rediscovering a family of means, *Math. Intelligencer*, 24.2 (2002) 58–65.
- [156] C. Waiveris and Y. Chen, Folding stars, *College Math. Journal*, 30 (1999) 370–378.
- [157] M. Wald, Solution to Problem 1664, *Journal of Recreational Math.*, 21 (1989) 236–237.
- [158] J. E. Waltrom and M. Berg, Prime primes, *Math. Mag.*, 42 (1969) 232.
- [159] W. C. Waterhouse, Continued fractions and Pythagorean triples, *Fibonacci Quarterly*, 30 (1992) 144–147.
- [160] A. Wayne, A genealogy of 120° and 60° natural triangles, *Math. Mag.*, 55 (1982) 157–162.
- [161] C. S. Weaver, Geoboard triangles with one interior point, *Math. Mag.*, 50 (1977) 92–94.
- [162] D. Wells, Beauty in mathematics, *Math. Intelligencer*, 10:4 (1988) 31.
- [163] D. T. Whiteside, *The Mathematical Papers of Issac Newton*, vol. V, Cambridge University Press, 1976.
- [164] A. W. Willcox and L. A. Ringenberg, Problem 971, *American Math. Monthly*, 58 (1951) 417; solution 59 (1952) 105–106.

- [165] P. Woo, Simple constructions of the incircle of an arbelos, *Forum Geometricorum*, 1 (2001) 133–136.
- [166] M. Wunderlich, Another proof of the infinite primes theorem, *American Math. Monthly*, 72 (1965) 305.
- [167] S. Yates, The mystique of repunits, *Math. Mag.*, 51 (1978) 22–28.
- [168] S. Yates, Periods of unique primes, *Math. Mag.*, 53 (1980) 314.
- [169] S. Yates, *Repunits and Repetends*, privately published, Delray Beach, FL, 1982.
- [170] P. Yiu, Construction of indecomposable Heronian triangles, *Rocky Mountain Journal of Mathematics*, 28 (1998) 1189 – 1202.
- [171] P. Yiu, Mixtilinear incircles, *Amer. Math. Monthly*, 106 (1999) 952 – 955.
- [172] P. Yiu, The uses of homogeneous barycentric coordinates in plane euclidean geometry, *Int. J. Math. Educ. Sci. Technol*, 31 (2000) 569 – 578.
- [173] P. Yiu, Heronian triangles are lattice triangles, *Amer. Math. Monthly*, 108 (2001) 261 – 263.
- [174] P. Yiu, The volume of an isosceles tetrahedron and the Euler line, *Mathematics & Informatics Quarterly*, 11 (2001) 15–19.
- [175] N. Yoshigahara, Card-return numbers, *Journal of Recreational Math.*, 5 (1972) 36–38.