



THE HIGHWAYS AGENCY

BE 5/75



THE SCOTTISH OFFICE DEVELOPMENT DEPARTMENT



THE WELSH OFFICE
Y SWYDDFA GYMREIG



THE DEPARTMENT OF
THE ENVIRONMENT FOR NORTHERN IRELAND

Technical Memorandum (Bridges) Rules for the Design and Use of Freyssinet Concrete Hinges in Highway Structures

Summary:

VOLUME 1	HIGHWAY STRUCTURES: APPROVAL PROCEDURES AND GENERAL DESIGN
-----------------	---

BE 5/75

**TECHNICAL MEMORANDUM
(BRIDGES)**

**RULES FOR THE DESIGN AND USE
OF FREYSSINET CONCRETE
HINGES IN HIGHWAY STRUCTURES**

Contents

Sections

Foreword

1. General
2. Materials
3. Design
4. Workmanship
5. Enquiries

Appendix A

Appendix B

RULES FOR THE DESIGN AND USE OF FREYSSINET CONCRETE HINGES IN HIGHWAY STRUCTURES

This Technical Memorandum in Metric Units replaces the Ministry of Transport Memorandum No. 577/1 published by HMSO in 1966.

The accompanying documents, i.e., SECTION ONE TO SECTION FOUR and Appendices A and B, give the rules for the design and use of Freyssinet concrete hinges.

The rules are based on the results of a programme of research carried out by the Cement and Concrete Association, and financed jointly by the Association and the Department of the Environment.

It is intended that they shall be periodically reviewed, and amended where experience or the results of research shows this to be necessary.

1. GENERAL

101 Application

The present trend towards longer spans and continuous elevated highway structures necessitate the use of Freyssinet type hinge to permit large rotation, eg., in viaducts with inclined trestles, and in short columns supporting a multispan bridge.

Limitation of Use

This type of hinge should not be used:

- (a) Where there is risk of a collision with the structure causing damage or displacement of the hinge.
- (b) Where under any loading there is a resultant uplift on all or part of the hinge.

102 Scope

The rules have been drafted on the assumption that the detailed hinge design will be prepared by structural or civil engineers experienced in the structural use of concrete and that the execution of the work is carried out under the direction of a competent supervisor familiar with the technique of making high quality concrete. They are intended to be applied only to the Freyssinet hinge in which reinforcement through the throat of the hinge, when provided, does not exceed three per cent of the cross-sectional area of the throat. The rules assume that the rotation takes place in one plane only and that the shear across the throat does not exceed one third of the axial load under any condition of loading.

103 Definitions (see fig. 1)

Height	Measured along the axis of the member of which the hinge forms part.
Length	Measured along the axis of bending of the hinge.
Width	Measured perpendicular to the axis of bending of the hinge and to the axis of the member of which the hinge forms part.
Throat	The minimum width of the hinge.
Shoulder	The portion between edge of member and edge of throat.
Notches	The recesses in the member, forming the hinge.

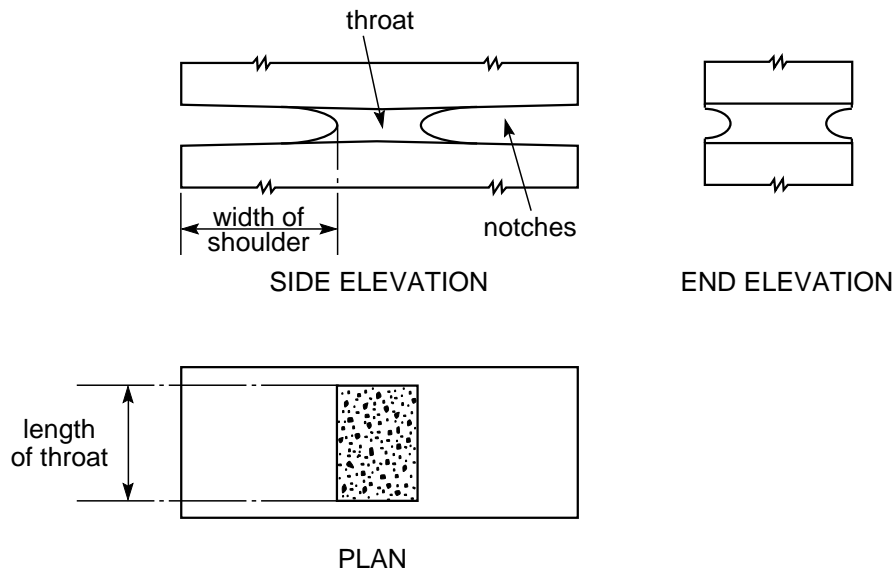

FIG. 1

104 Symbols

- a Full width of member.
- a_1 Width of throat.
- E Modulus of elasticity of concrete in compression for short term loading.
- ϕ Rotation of hinge (See Fig. 3, Appendix A).
- ϕ_e Equivalent rotation using short term value of E only.
- h_e Effective height of throat = ϕR (See Fig. 3, Appendix A).
- k Notch factor = $\frac{\text{compressive stress at edges of throat due to axial loading}}{\text{average compressive stress in throat due to axial loading}}$
- P Axial load per unit length of hinge. (N/mm)
- R Effective radius of curvature of hinge (See Fig. 3, Appendix A).
- S Shear force across hinge. (N/mm)
- u_w The specified works test tube crushing strength of the concrete at 28 days.
- u The works test cube crushing strength of the concrete at any particular time.

2. MATERIALS

201 Concrete

The specified works test cube strength u_w of the concrete in the hinge shall be not less than 45 N/mm². The size of aggregate in the concrete around the transverse mat reinforcement and in the throat shall not exceed 10 mm.

202 Steel

The reinforcement shall be of mild steel conforming to BS 4449: 1969 'Hot rolled steel bars for the reinforcement of concrete'.

3. DESIGN

301 Basic Assumptions

- (a) The effect of any reinforcing steel which may be incorporated in the throat of the hinge for ease of handling is neglected.
- (b) The effect of shrinkage cracks in the throat is neglected.
- (c) For short term loading the behaviour of the concrete is elastic.
- (d) For long term loading the creep is proportional to the initial stress.
- (e) In considering the transverse tensile forces on either side of the throat the tensile strength of the concrete is neglected.

302 Loadings

The loadings shall be as specified in British Standard 153: Part 3A: 1972 and in Department of the Environment Technical Memorandum (Bridges) BE 5/75 'Standard Highway Loadings'. In addition the hinges shall be designed to withstand all loadings which may be applied during construction. See Clause 403.

303 Permissible Stresses

- (a) Concrete

The average compressive stress in the concrete in the throat shall not exceed $2 u_w$ or 105 N/mm^2 whichever is the lesser. Tensile stresses in the throat shall not be permitted except for shrinkage stresses which may arise during construction.

- (b) Steel

The stresses in the transverse mat reinforcement shall not exceed 105 N/mm^2 .

304 Design of Throat

- (a) The design of the throat is dependent on:
 - (i) the maximum load to be carried, and
 - (ii) the maximum value of rotation per unit load.
- (b) The basis of calculation is given in Appendix A and shall be used for the design of the width of throat, which shall be not less than 50 mm or such value as will provide a minimum cover of 25 mm to any reinforcement in the throat.
- (c) The values given in Tables 1 and 2 have been calculated by the method given in Appendix A. These cover all normal cases and enable the designer to see whether a throat of given width can accommodate a given loading and the rotations due to long and short term causes. For simplicity of use the short term value of E has been taken for both long and short term effects in these tables. The rotations due to shrinkage, creep, elastic shortening and permanent loading must

therefore be halved before being added to the rotations due to temperature and transient loading (see Appendix A).

TABLE 1

$$u_w = 45 \text{ N/mm}^2 \text{ at 28 days}$$

$$E = 32.5 \text{ kN/mm}^2$$

Equivalent rotation $\phi_e =$ (rotation due to live loads and temperature) + $\frac{1}{2}$ (rotation due to shrinkage, creep, elastic shortening and dead load).

Throat Width a_1 (mm)	Maximum Axial Compressive Load P max/unit Length of Throat (N/mm)	Maximum Permissible Value of $\frac{\phi_e}{P}$ (radians/(N/mm))
50	4200	475×10^{-8}
62.5	5250	305×10^{-8}
75	6300	210×10^{-8}
87.5	7350	155×10^{-8}
100	8400	120×10^{-8}
112.5	9450	90×10^{-8}
125	10500	75×10^{-8}

TABLE 2

$$u_w = 52.5 \text{ N/mm}^2 \text{ at 28 days}$$

$$E = 34.5 \text{ kN/mm}^2$$

Equivalent rotation $\phi_e =$ (rotation due to live loads and temperature) + $\frac{1}{2}$ (rotation due to shrinkage, creep, elastic shortening and dead load).

Throat Width a_1 (mm)	Maximum Axial Compressive Load P max/unit Length of Throat (N/mm)	Maximum Permissible Value of $\frac{\phi_e}{P}$ (radians/(N/mm))
50	5250	440×10^{-8}
62.5	6550	280×10^{-8}
75	7900	195×10^{-8}
87.5	9200	145×10^{-8}
100	10500	110×10^{-8}

- (d) The maximum value of rotation per unit axial load often occurs under the most lightly loaded condition and must be determined for each condition of loading.
- (e) The shape of the notch in the immediate vicinity of the throat should approximate to a parabola as shown in Fig. 2. The curve should merge into parallel straight lines which continue to the edges of the member. (A divergence of up to 1 in 20 may be allowed to facilitate easy withdrawal of the formwork).

Each end of a length of throat would be recessed at least 75 mm from the face of the member to prevent spalling at the ends of the throat.

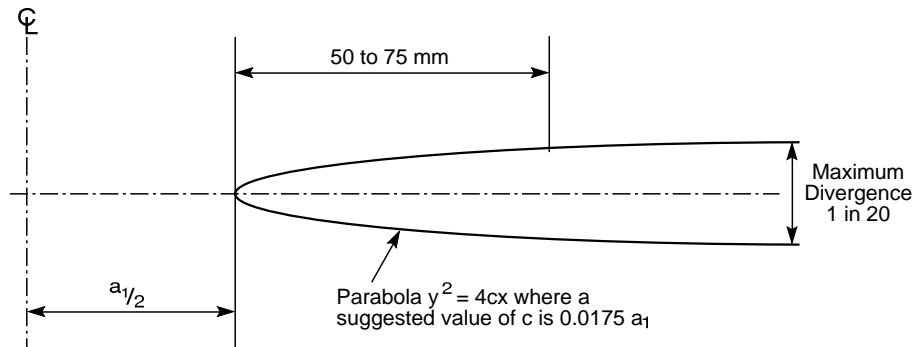

TYPICAL SHAPE OF NOTCH

FIG. 2

305 Transverse Reinforcement

The concentrated compressive force in the throat of the hinge induces transverse tensile forces in the adjacent members. These forces shall be deemed to extend over zones above and below the throat for a distance from the horizontal centre line of the throat equal to the width of the member. A primary tensile force acting in the direction of the width of the member together with a secondary force acting horizontally at right angles to it shall be resisted by mats of reinforcement in the tensile zone. The primary tensile force per unit length of member shall be taken as 3/8 of the resultant of the direct and shear forces acting over that length and the ratio of

$\frac{\text{secondary force per unit width of member}}{\text{primary force per unit length of member}}$ shall be taken to be 1/3.

All the mats in each member shall be contained within the tensile zone of the member, and as many as possible within the half of the tensile zone nearest the throat. The edges of each mat shall be 25 mm from the sides of the member containing it and the mat nearest the throat shall have 25 mm cover between it and the faces of the notch.

Primary and secondary mats which consist of a single bar bent alternately right and left with a minimum radius of $2d$ may be separate or spot welded together if required. Where a welded mesh is used the joints in shear shall withstand the ultimate load which the primary bars can transmit. The mats should be detailed so as to permit the proper compaction of the concrete and the distance between bars sensibly parallel shall nowhere be less than 20 mm. Examples of typical mats and a table of their capacities are given in Appendix B.

4. WORKMANSHIP

401 General Requirements

Workmanship shall comply with the requirements of the current Department of the Environment 'Specification for Road and Bridge Works'.

402 Position of Construction Joints

Construction joints shall not be formed through the throat. Where a joint is necessary it is recommended that it should be formed as a recess below the throat, level with the top reinforcement mat. The width of the recess should be slightly greater than the width of the throat.

403 Protection of Joint During Construction

Wherever possible hinges shall be adequately supported to prevent rotation at the throat from the time of casting to the completion of the structure incorporating it. The permissible loads, rotations and shears during this period shall be related to each other and to the strength of the concrete (u) in accordance with Appendix A, Para. 7 (b, c and d); u_w being replaced in 7(b) by u , when u has the lesser value. Care shall be taken that the requirements of Clause 101 are observed.

404 Inspection

So far as practicable, provision should be made to enable hinges to be inspected in service.

5. ENQUIRIES

Technical enquiries regarding the design rules contained in the Technical Memorandum should be addressed to:-

MH Wisniewski
Bridges Engineering Standards Division
Department of Transport
St Christopher House
Southwark Street
LONDON SE1 0TE

In case of telephone enquiries please phone 01 928 7999 Ext 4825 or 2130

Application for copies of this memorandum should be sent to:

The Highways Manual Branch
Room P2/017A
Department of the Environment
2 Marsham Street
LONDON SW1 3EB
Telephone: 01-212 4944

APPENDIX A

The data given in Tables 1 and 2 has been arrived at from the following considerations:

1. If a hinge is to sustain large rotations without causing tensile stress in the throat, the width of the throat must be considered in relation to the required rotation. Experimental work has shown that the behaviour of the concrete is elastic for short term loading and that under long term loading the creep is proportional to the initial stress. It is therefore possible to calculate from elastic considerations the rotation ϕ which, rapidly applied, would just cause annulment of the compression on one side of the throat. (See Figs. 3 and 4.)

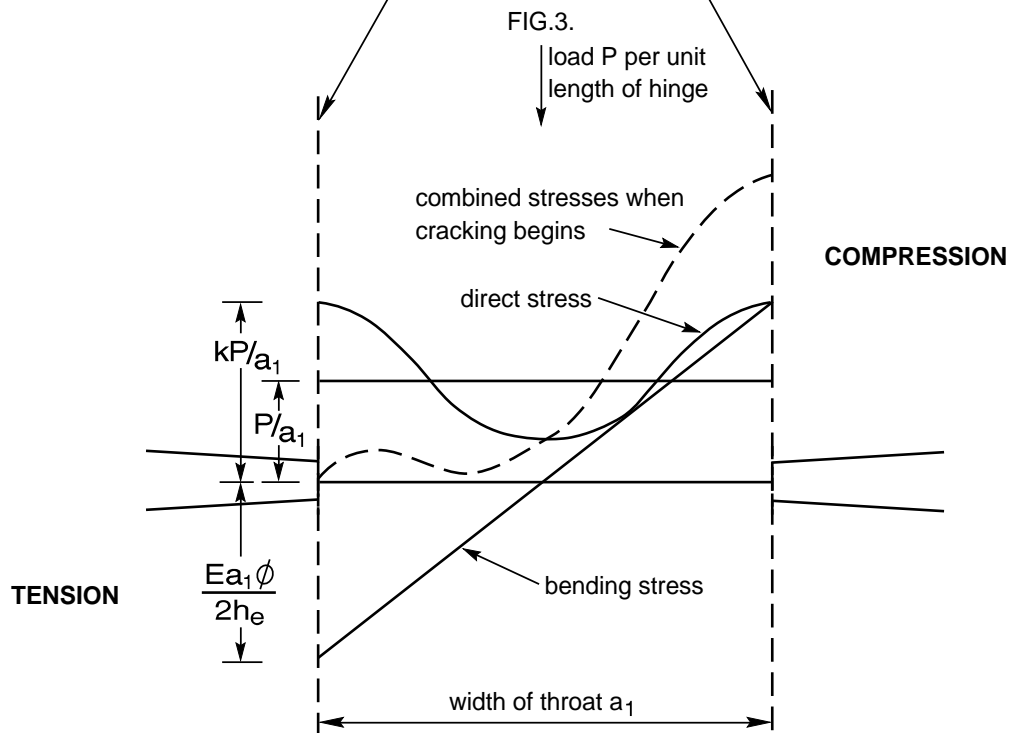
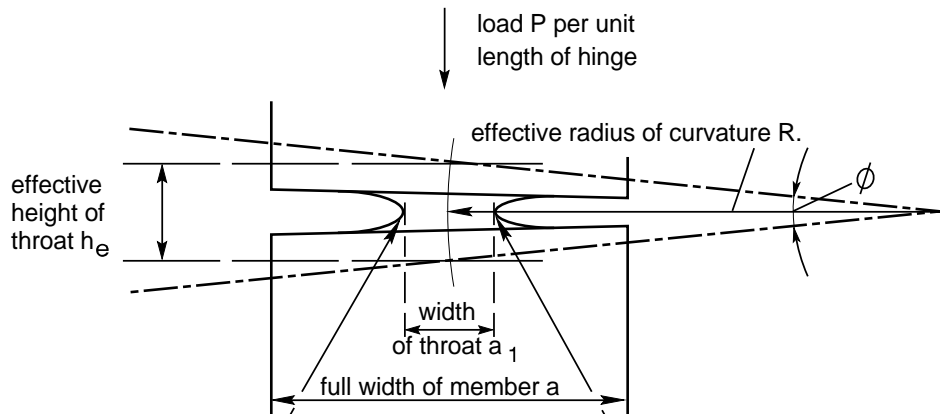

Appendix A

2. The stress distribution across the throat for an axial compressive load is of the form shown in Fig. 4, the maximum stresses being at the sides of the throat.

Tests have shown that if this maximum stress is defined as $\frac{kP}{a_1}$ then the notch factor k may be taken to be 1.5 for the range of tests carried out (i.e., for the throat widths up to 200 mm). This covers the hinges likely to be used in highway bridges.

3. Let P_b = the extreme fibre bending stress due to a superimposed moment in the hinge then:

$$\pm \frac{2P_b}{a_1} = \frac{E}{R} = \frac{E\phi}{h_e}$$

or $P_b = \pm \frac{E a_1 \phi}{2 h_e}$

4. If there are to be no tensile stresses in the throat it is necessary that the maximum direct compressive stress at the sides shall be greater than or equal to the maximum bending stress at any time. This may be expressed as:

$$\frac{1.5P}{a_1} \geq \frac{a_1}{2 h_e} \times \sum E\phi$$

where $\sum E\phi$ represents the sum, at any time, the products of rotation and modulus of elasticity for each type of loading.

It has been found experimentally that h_e , the effective height of the throat, can be taken to be 125 mm and hence the above expression may be rewritten as:

$$\frac{\sum E\phi}{P} \leq \frac{380}{a_1^2}$$

5. The value of the modulus of elasticity of the hinge for long term rotations due to shrinkage, creep, elastic shortening and permanent loads shall be taken as being half that for temperature and transient loads.

If $E =$ Modulus of elasticity for temperature and transient loads
 $\phi_s =$ total rotation due to transient loads and temperature
 $\phi_L =$ total rotation due to shrinkage, creep, elastic shortening and permanent loads

Then $\sum E\phi = E \phi_s + \frac{E \phi_L}{2}$
 $= E (\phi_s + \frac{\phi_L}{2}) = E \phi_e$

Hence only half the actual value of ϕ_L should be included in the calculation of the equivalent rotation per unit axial load when using Tables 1 and 2.

6. When the limiting value of zero tension on one side of the throat is reached it follows that the maximum compressive stress on the other side will be $2 \times 1.5 P / a_1$, i.e., three times the average compressive stress P / a_1 . Testing has shown that under these conditions working values of the average compressive stress may safely be as much as twice the 28 day cube strength of the concrete or 105 N/mm^2 whichever is the lesser.

7. The limiting conditions for the width of the throat can be summarised as follows:-

(a) $a_1 \geq 50 \text{ mm}$

(b) $a_1 \geq \frac{P}{2u}$

$$(c) \quad a_1 \geq \frac{P}{105}$$

$$(d) \quad a_1 \leq \sqrt{E \left(\frac{380P}{\phi_s + \phi_L/2} \right)}$$

Where the limiting values of throat width given by (a), (b) or (c) are incompatible with that given by (d) this type of hinge should not be used.

8. Values of E for concrete with a cube strength within the range given by Tables 1 and 2 may be lineally interpolated.

APPENDIX B

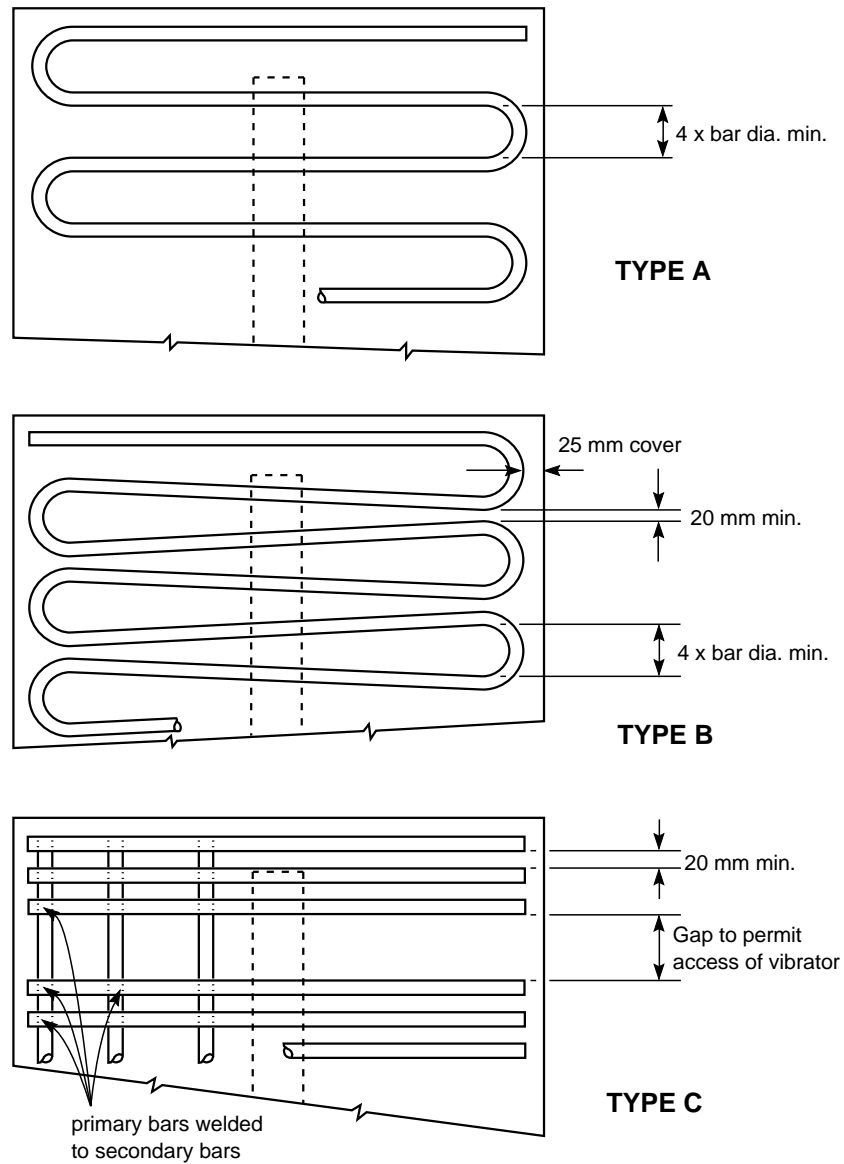

TYPICAL DETAILS OF TRANSVERSE MAT REINFORCEMENT.

FIG. 5.

Appendix B

Maximum cross-sectional areas and capacities of transverse mat reinforcement.
(No allowance has been made for special provision of access for poker vibrators.)

Mat type A

Bar diameter mm	Steel area per mat per metre mm ²	Tensile capacity per mat per metre N*	Number of mats required for a hinge load $\sqrt{(P^2 + s^2)}$ of 1750 N/mm
10	1570	165000	4.00
12	1810	190000	3.45
16	2410	253000	2.59
20	3140	329000	2.00

Mat type B

10	1960	206000	3.19
12	2490	261000	2.51
16	3420	359000	1.83
20	4400	462000	1.42

Mat type C

10	2590	272000	2.41
12	3730	392000	1.67
16	5630	591000	1.10
20	7850	824000	0.80

* Based on allowable stress of 105 N/mm²