

NOTES.

1. DRILL & TAP #6-40 N.C. AFTER PRESSING IN ITEM 6.
2. SEE SHEET 1 FOR BILL OF MATERIAL.

REVISION	DESCRIPTION	DATE

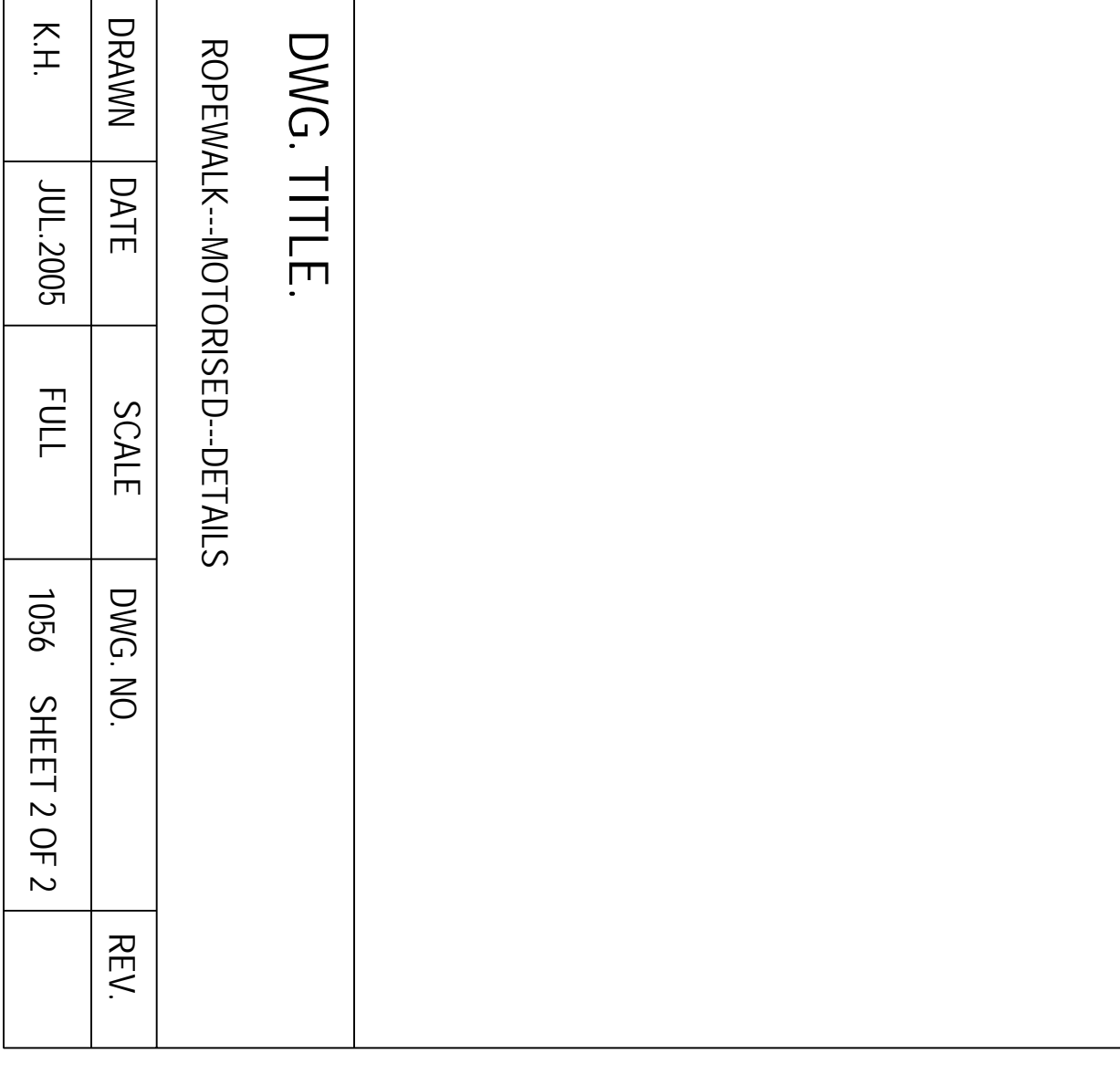
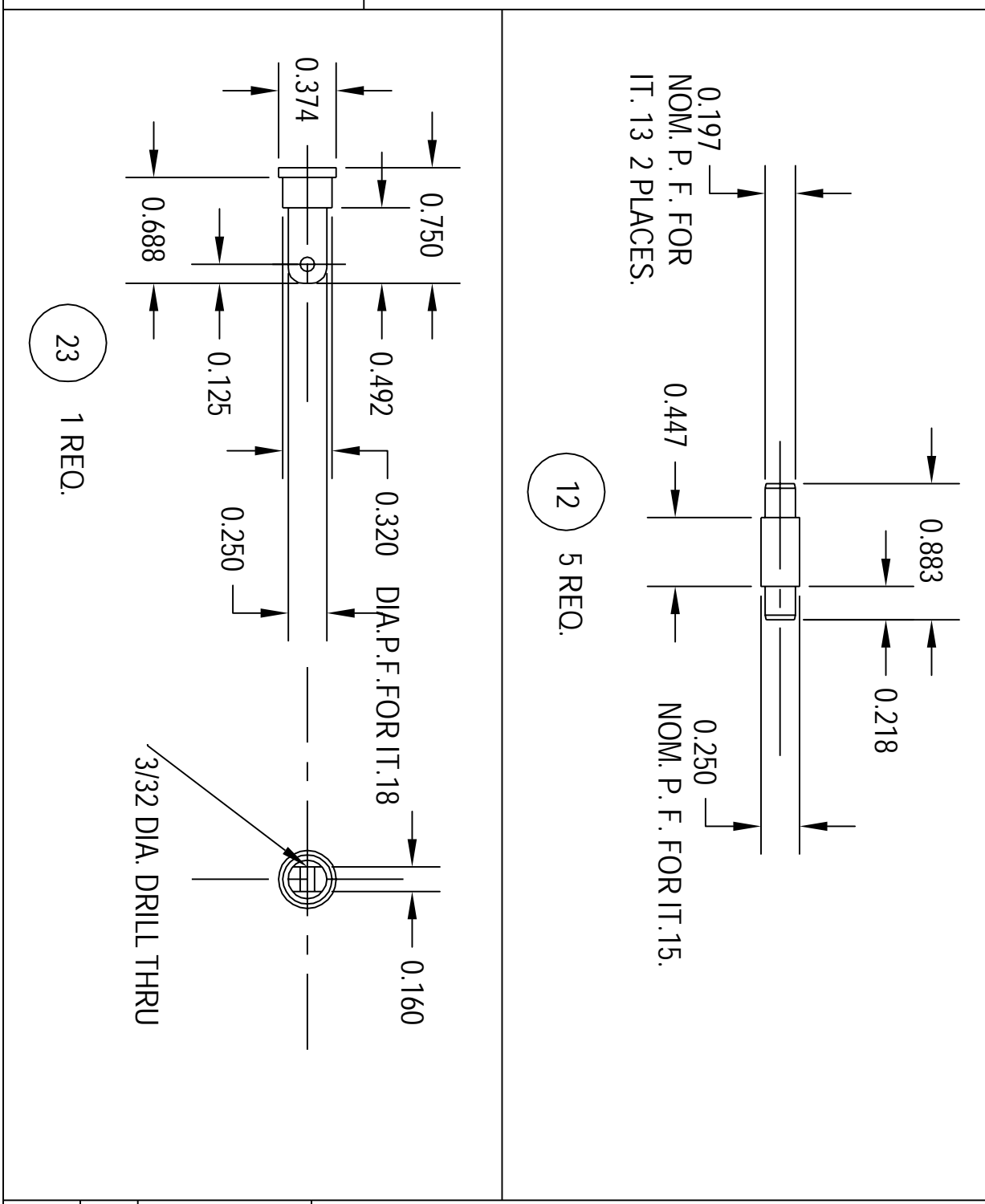
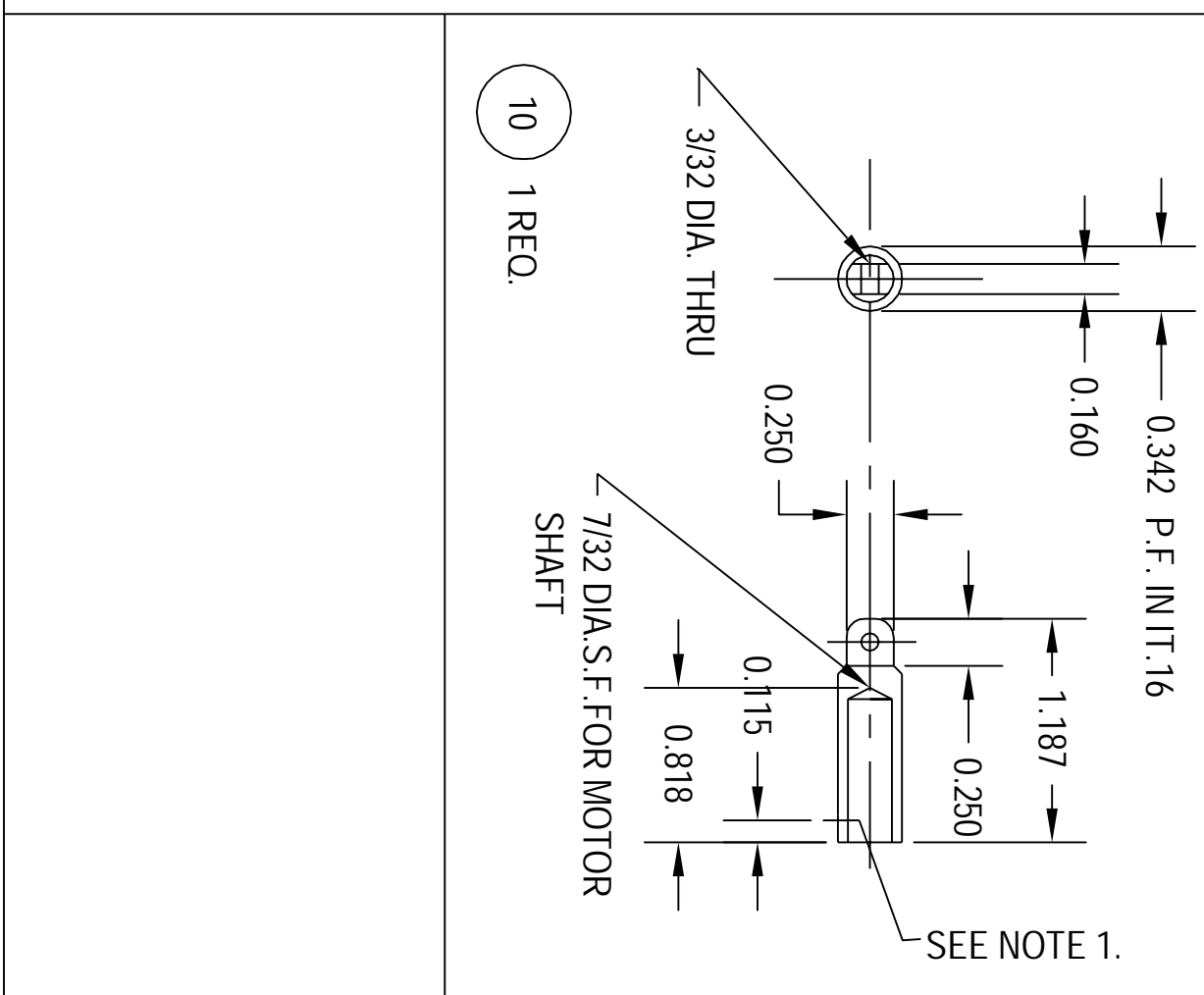
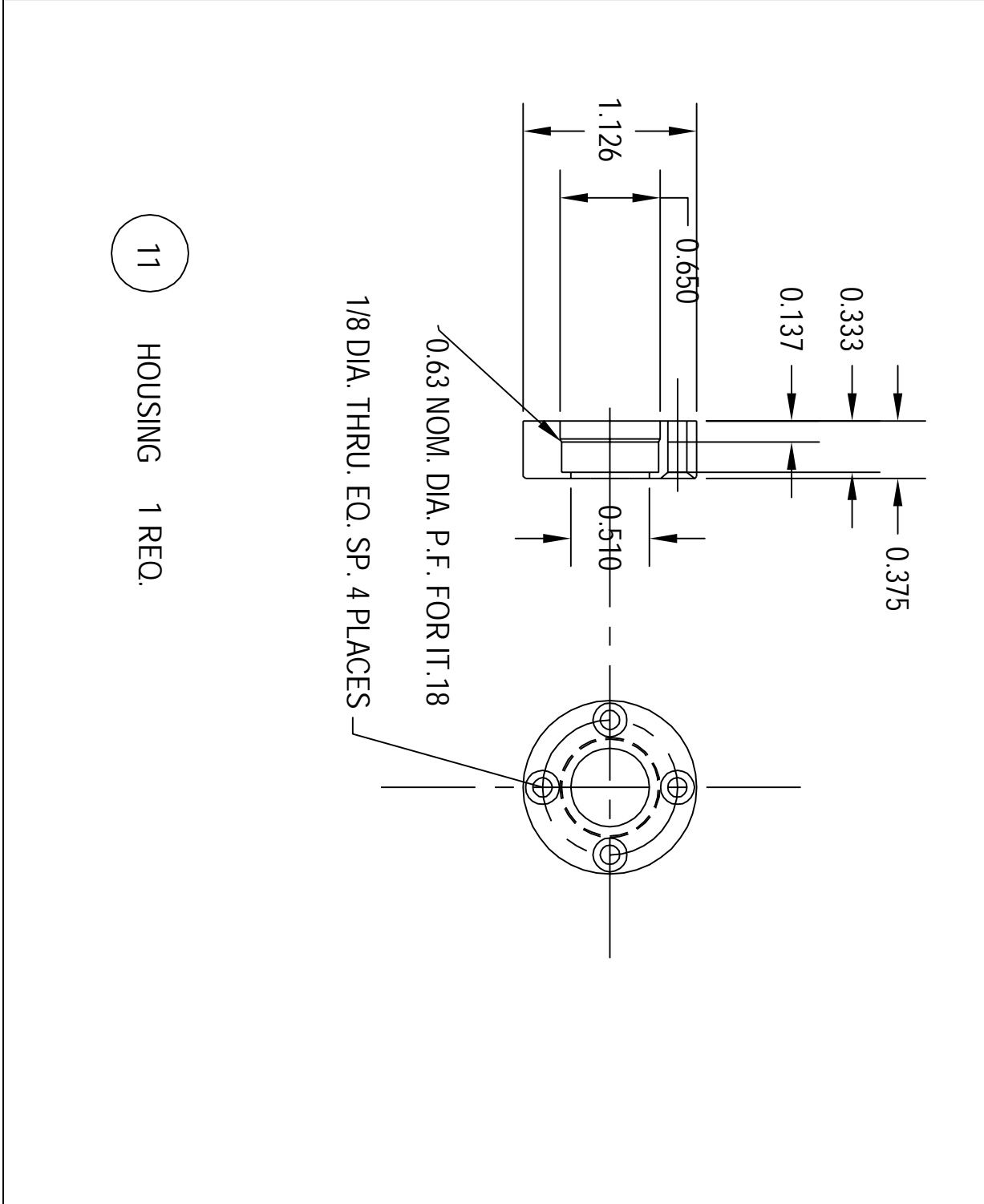
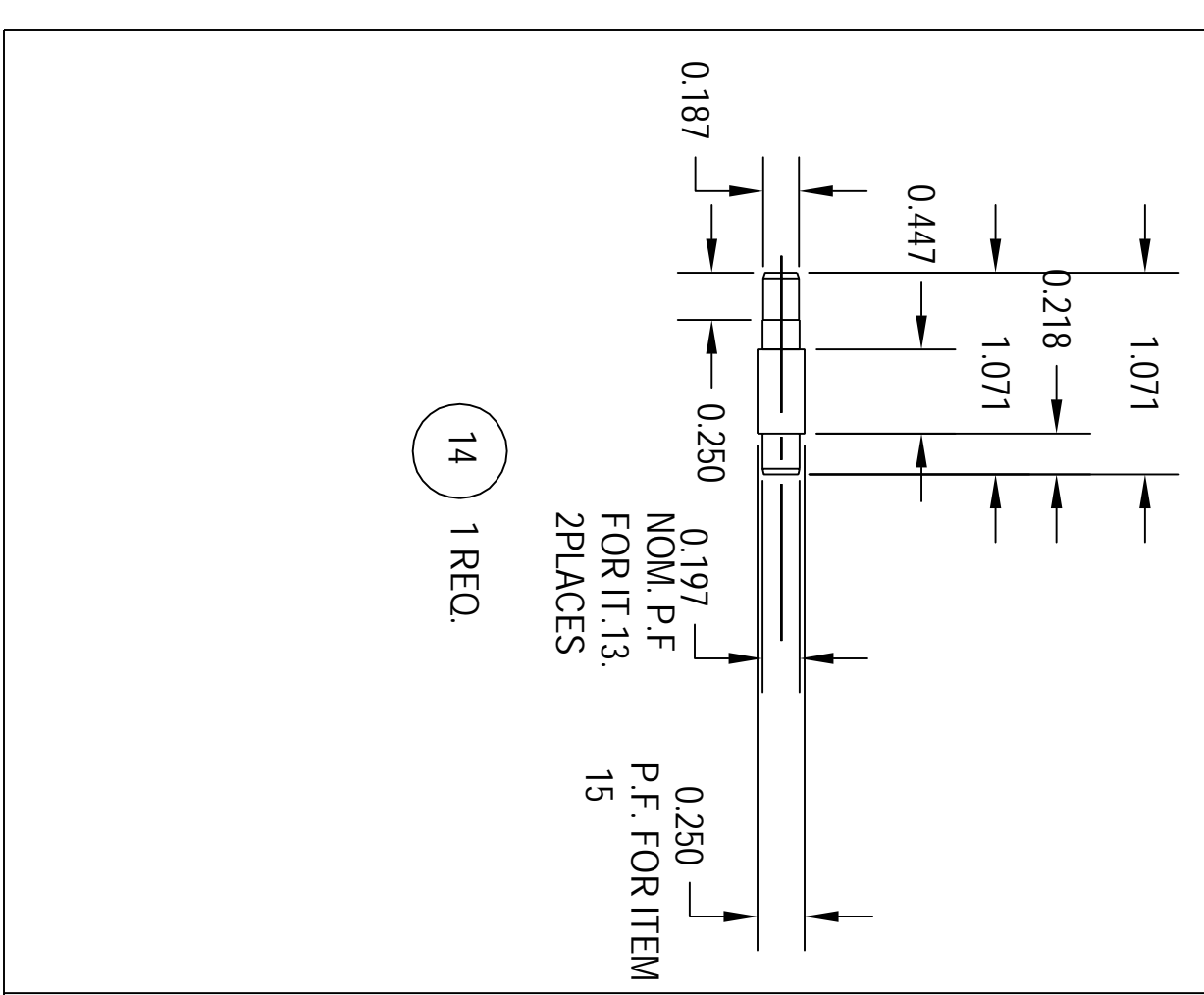
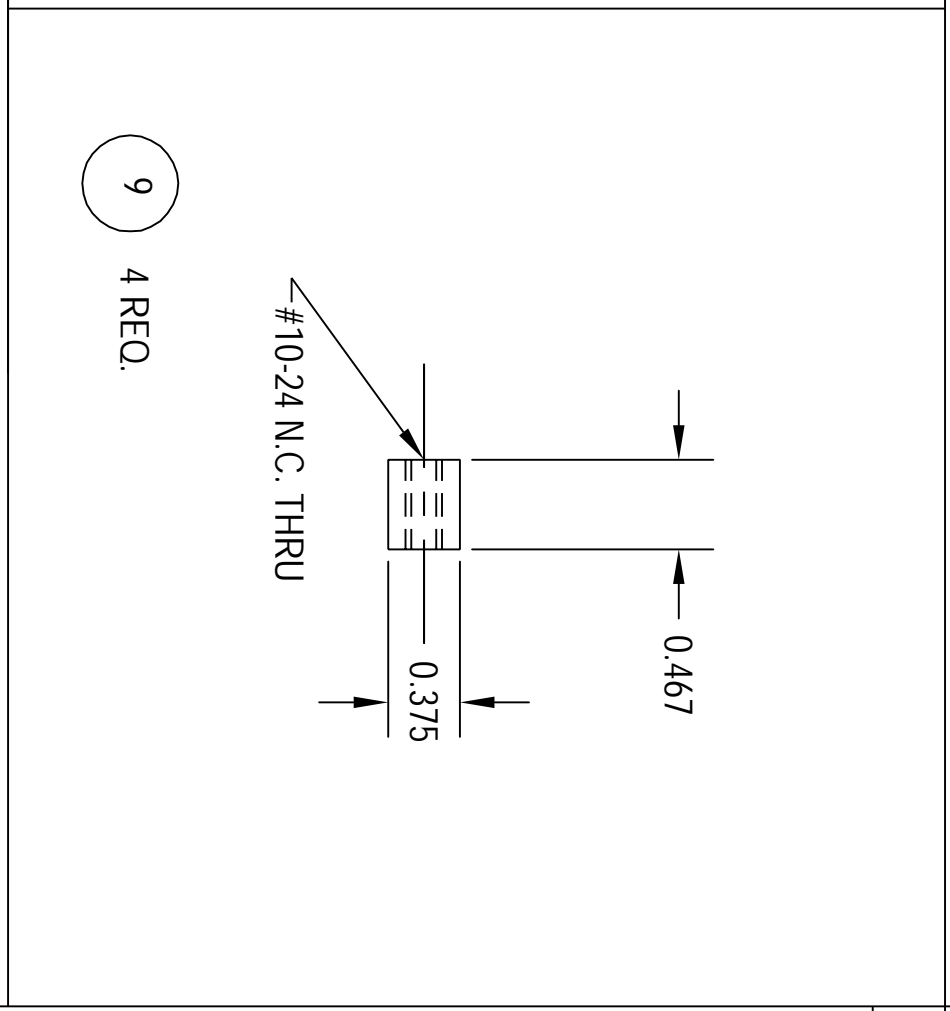
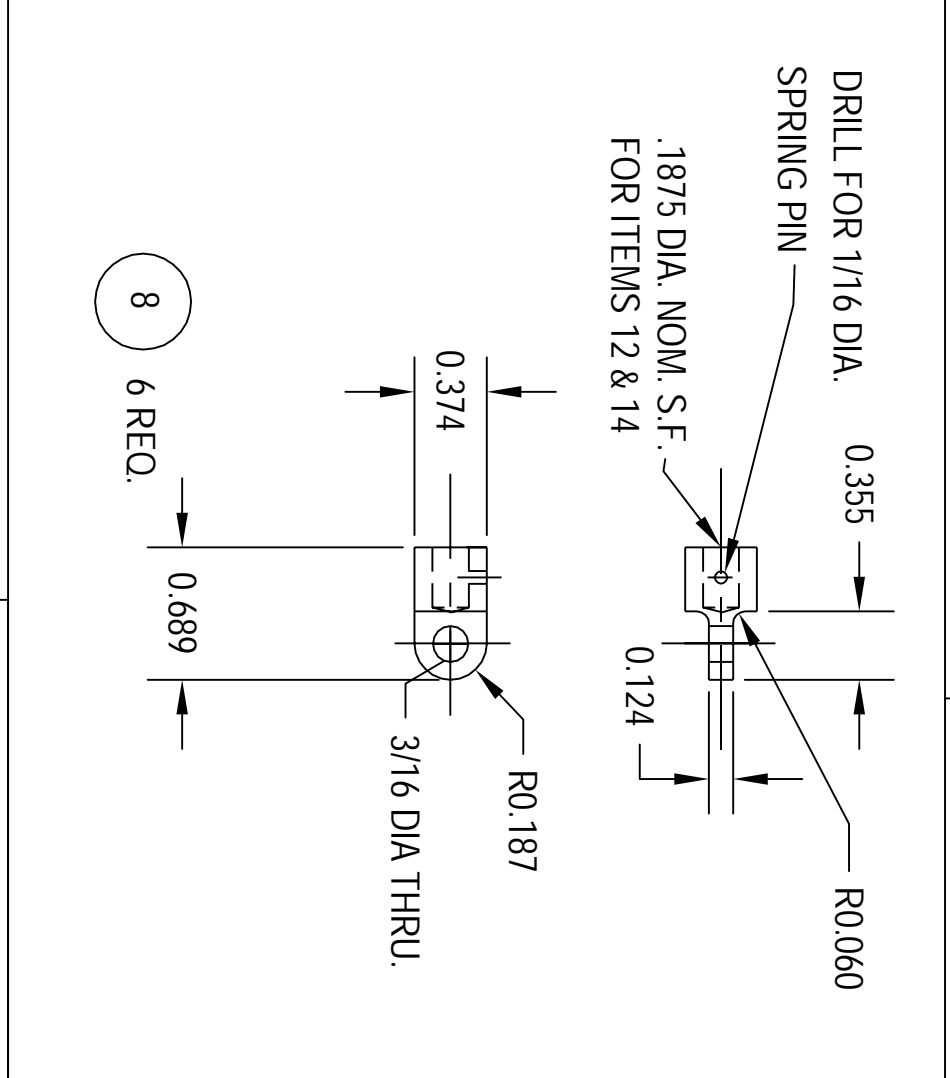
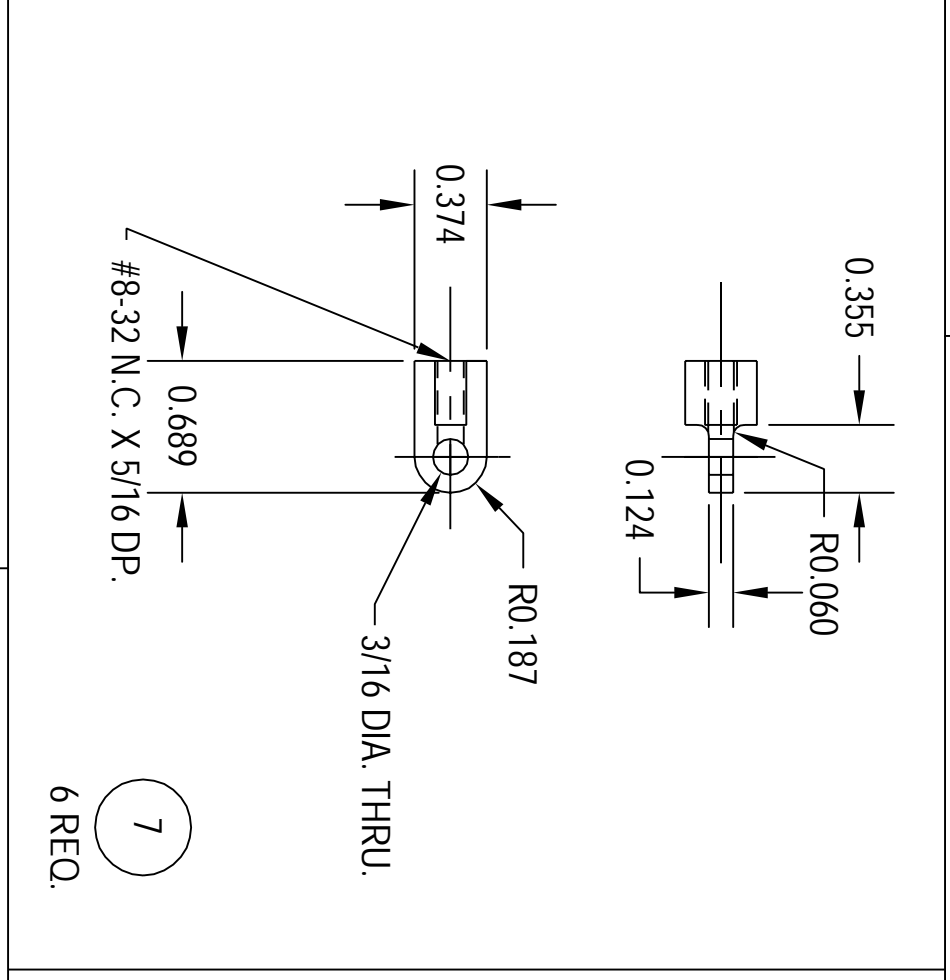
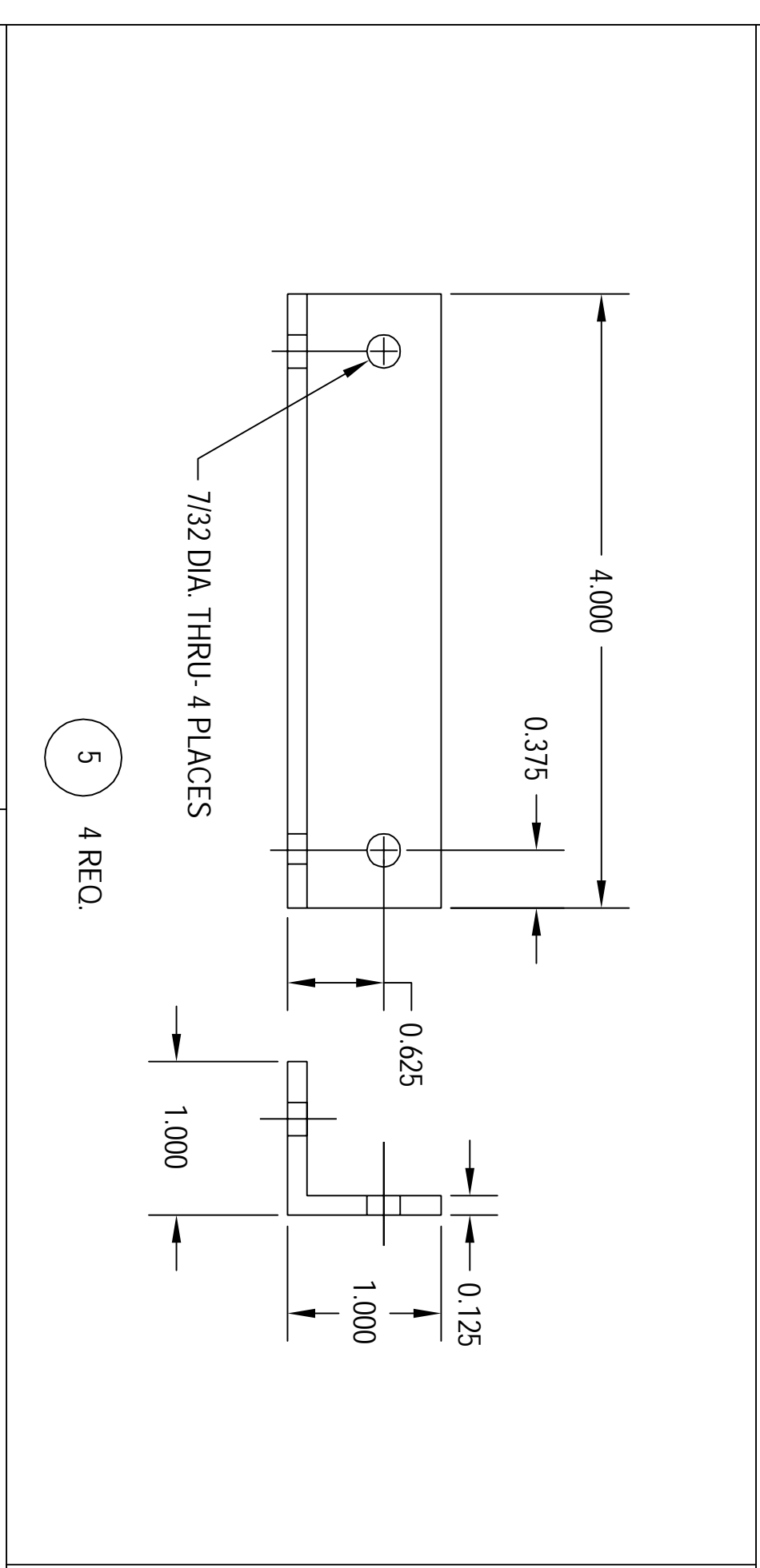

DWG. TITLE.
ROPEWALK---MOTORISED---DETAILS

DRAWN	DATE	SCALE	DWG. NO.	REV.
K.H.	JUL.2005	FULL	1056	SHEET 2 OF 2